

**SIDE VIEW RETRACTED**

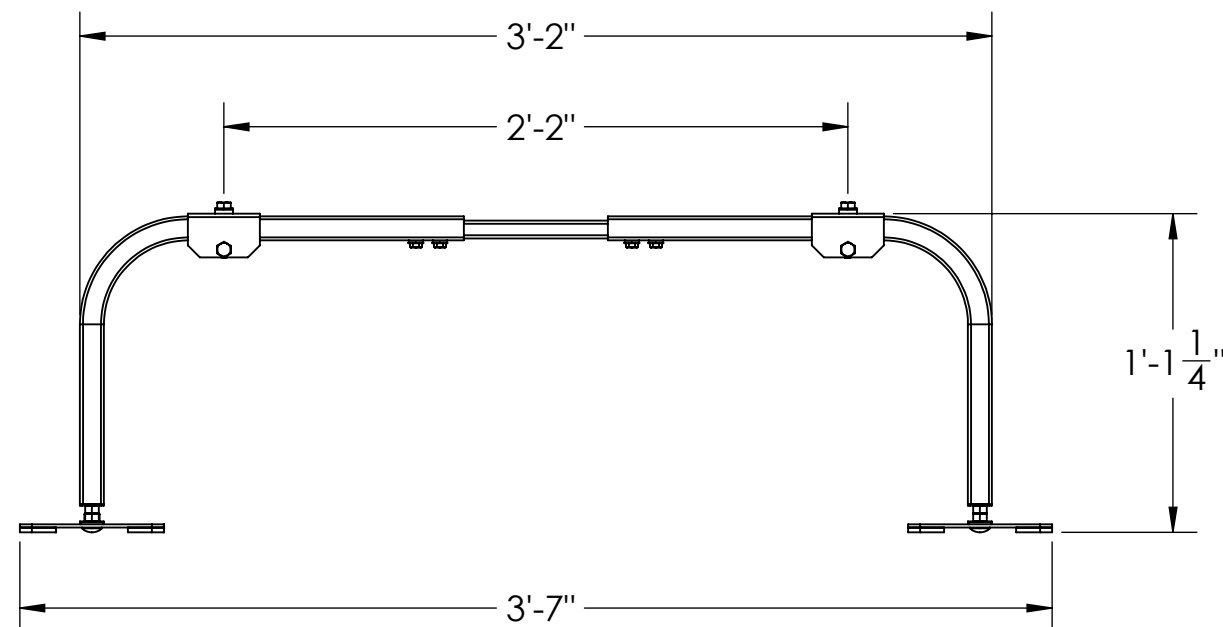

**SIDE VIEW EXPANDED**

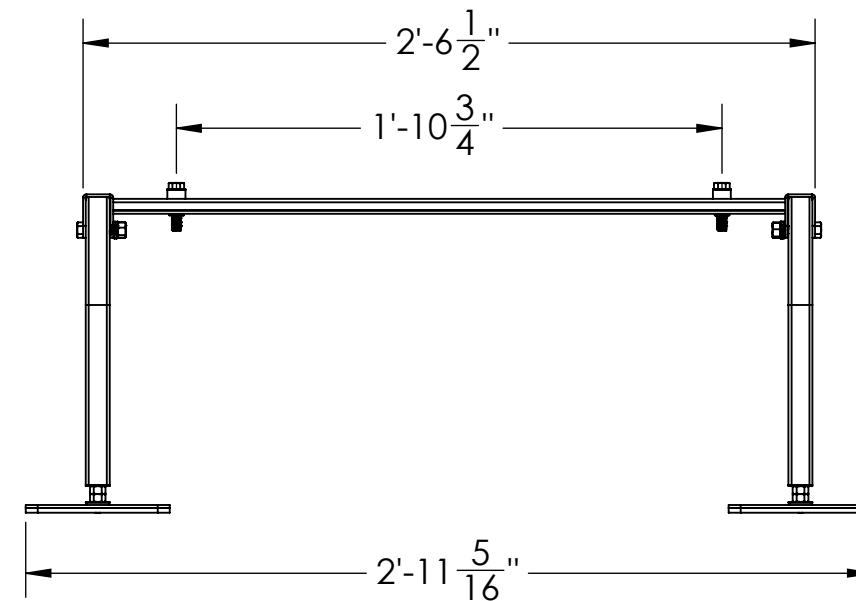

**END VIEW RETRACTED**

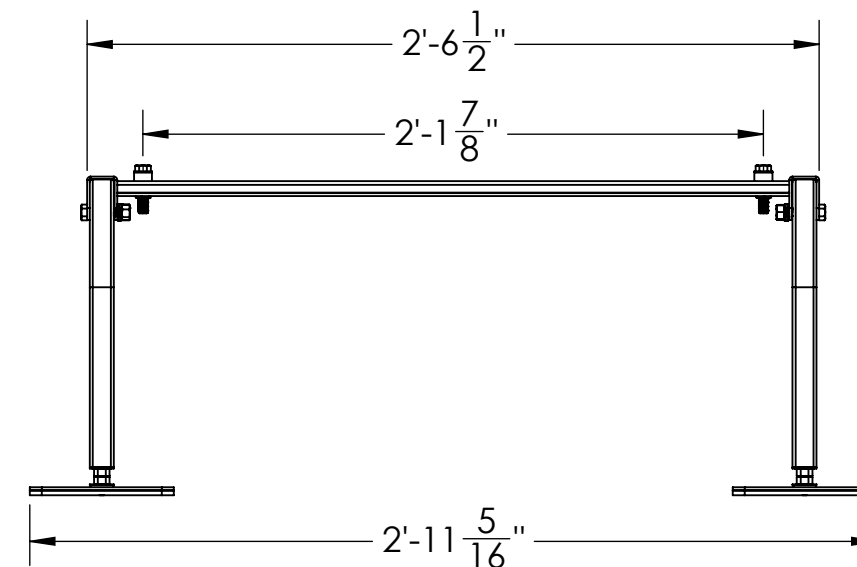

**END VIEW EXPANDED**

(\* ) - WIDTH IS ADJUSTABLE IN 1" INCREMENTS

**IMPORTANT NOTE: THE INSTALLER IS RESPONSIBLE FOR THETHERING AND BOLTING UNITS TO WITHSTAND WIND AND/OR SEISMIC LOADS.**

UNLESS OTHERWISE SPECIFIED:  
 DIMENSIONS ARE IN INCHES [MILLIMETERS]  
 TOLERANCES ARE: ANGLES ±1.0°  
 FRACTIONAL SIZES X/Y ±1/64

INCHES	[MILLIMETERS]
X = ±0.1	[ X = ± 2.5 ]
.XX = ±0.01	[ .X = ± 1.3 ]
.XXX = ±0.005	[ .XX = ± 0.13 ]

THIRD ANGLE PROJECTION



CONFIDENTIAL - PROPRIETARY - DO NOT COPY THE INFORMATION SET FORTH IN THIS DOCUMENT AND RELATED INFORMATION IS THE CONFIDENTIAL PROPERTY OF DIVERSITECH CORPORATION, AND IS NOT TO BE COPIED OR REPRODUCED OR DISTRIBUTED IN ANY FORM WITHOUT PRIOR WRITTEN PERMISSION FROM DIVERSITECH CORPORATION. DO NOT SCALE DRAWING	MATERIAL: DWG. NO. MINI SPLIT STAND - 1202 MODEL NO. QSMS1202	WEIGHT GMS. REV.
	DESCRIPTION	SHEET 1 OF 2

ITEM NO.	PART NUMBER	DESCRIPTION	Default/ QTY.
1	MS107	Mini Split 12in J-Bar	4
2	MS106	Mini Split Extension Bar	2
3	MS111	Long Mini Split Arm	2
4	MS105	Mini Split 6x6 Feet	4
5	QSR042	Mini Split Rubber Foot	8
6	QSR008	1/4-20x1/2in Zinc Hex Bolt	8
7	QSR015	1/4in Bonded Washers	8
8	HDKMS02	Hardware kit for QSMS1202	1

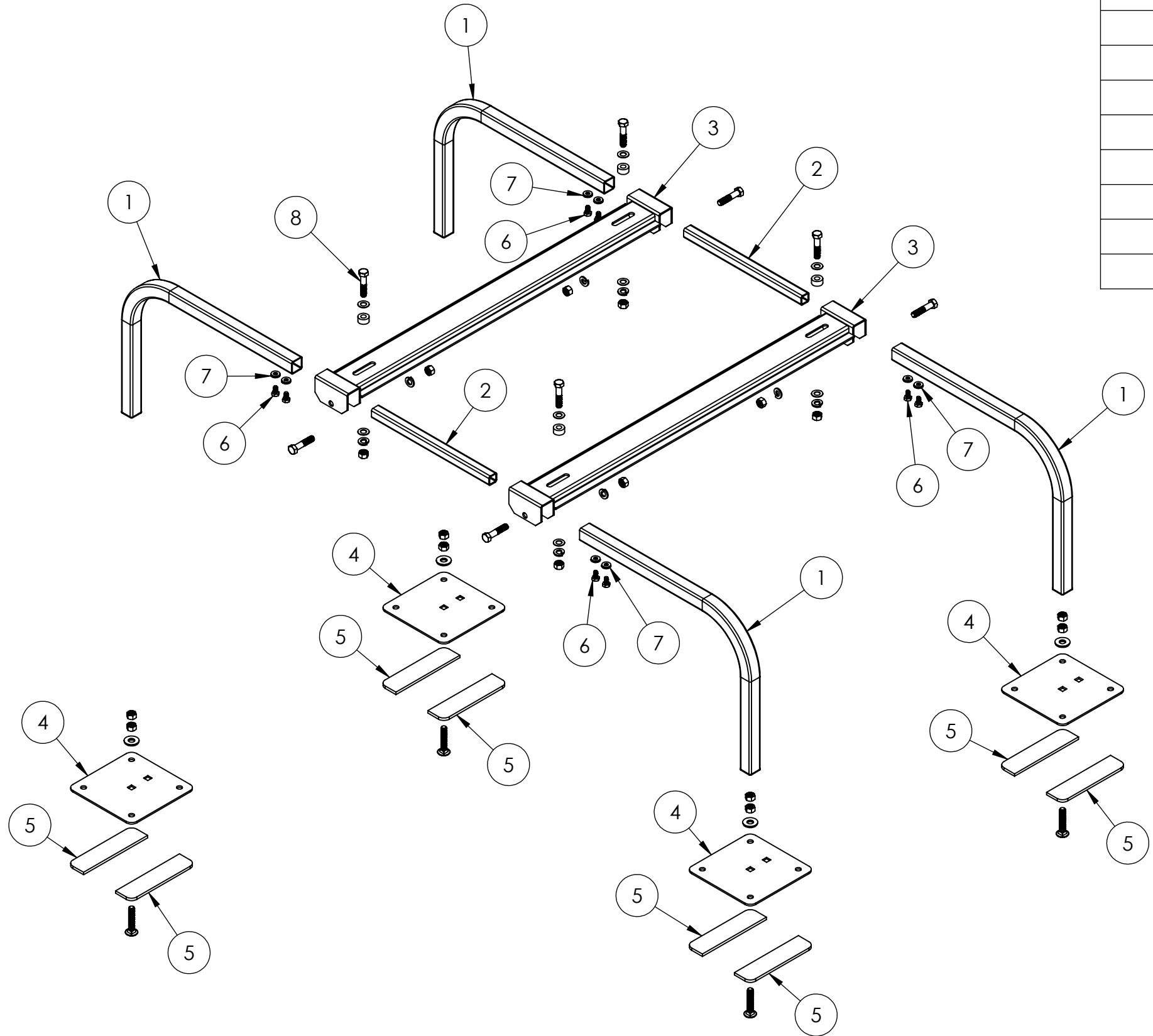

NOTE - ALL ASSEMBLY HARDWARE IS INCLUDED

UNLESS OTHERWISE SPECIFIED:  
 DIMENSIONS ARE IN INCHES [MILLIMETERS]  
 TOLERANCES ARE: ANGLES ±1.0°  
 FRACTIONAL SIZES X/Y ±1/64

INCHES	[MILLIMETERS]
.X = ±0.1	[ X = ± 2.5 ]
.XX = ±0.01	[ .X = ± 1.3 ]
.XXX = ±0.005	[ .XX = ±0.13 ]

THIRD ANGLE PROJECTION



CONFIDENTIAL - PROPRIETARY - DO NOT COPY THE INFORMATION SET FORTH IN THIS DOCUMENT AND RELATED INFORMATION IS THE CONFIDENTIAL PROPERTY OF DIVERSITECH CORPORATION, AND IS NOT TO BE COPIED OR REPRODUCED OR DISTRIBUTED IN ANY FORM WITHOUT PRIOR WRITTEN PERMISSION FROM DIVERSITECH CORPORATION. DO NOT SCALE DRAWING	MATERIAL: DWG. NO. MINI SPLIT STAND - 1202 MODEL NO. QSMS1202	WEIGHT GMS. REV.
	DESCRIPTION	SHEET 2 OF 2