



A CSW Industrials Company

Universal Bracket

WBB500 Wall Bracket
Product Code **87735**

Project Information:

Job Name: _____

Location: _____

Engineer: _____

Submitted to: _____

For: Reference Approval Construction

Submitted by: _____

Reference: _____

Submittal Information:

Approval: _____

Date: _____

Construction: _____

Unit #: _____

Drawing #: _____

(Sec. I) Ordering Information:

Product Code	87735
Model	WBB500
Carton Qty	1
Carton Weight	13 lbs

(Sec. II) Product Specifications:

Sheet Gauge:	14 gauge
Class of Galvanized Sheet:	GALVALUME
Type of Stainless Steel:	N/A
Load Rated Safety Factor:	3
Testing Load Rating to a Specific Testing Method:	Yes
Seismic Approval:	No
Hurricane Approval:	No
Type of Rubber Used for Isolator:	TPE rubber
UV Resistant:	Yes
Powder Coating:	Yes
Color of Powder Coating:	Beige
Overall Length:	33.50"
Overall Height:	17.75"
Overall Depth:	26.57"
Min/Max Mounting Depth:	10 3/8" to 19.5"
Min/Max Mounting Width:	3" to 31"
Max Load Capacity:	500 lbs

(Sec. III) Carton Contents:

- 2 x Bracket Arm
- 1 x Crossbar
- 6 x Hex Lag Screw
- 6 x 8 mm Concrete Anchor
- 4 x 1" Bolt and Clip Nut
- 1 x Liquid Level
- 2 x M6*16 Philip Head Screw
- 1 x Installation Instruction

(Fig. I) Product Image:

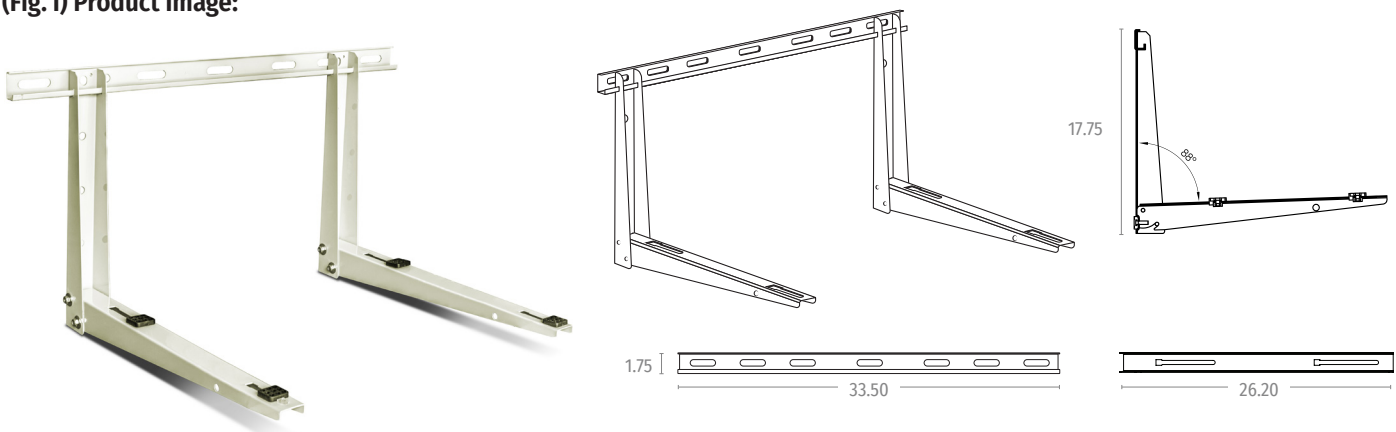

RectorSeal® • 2601 Spenwick Drive • Houston, TX 77055 • 800-231-3345 • rectorseal.com

A CSW Industrials Company. RectorSeal, the logos and other trademarks are property of RectorSeal, LLC, its affiliates or its licensors and are protected by copyright, trademark and other intellectual property laws, and may not be used without permission. RectorSeal reserves the right to change specifications without prior notice. ©2022 RectorSeal. All rights reserved. R50541-0422