

**34SCA5
ComfortSeries Air Conditioner
with Puron Refrigerant
1-1/2 to 5 Nominal Tons**



Turn to the experts

PRODUCT DATA



This unit has been designed utilizing Puron® refrigerant. This environmentally sound refrigerant allows you to make a responsible decision in the protection of the earth's ozone layer.

NOTE: Ratings contained in this document are subject to change at any time. Always refer to the AHRI directory (www.ahridirectory.org) for the most up-to-date ratings information.

INDUSTRY LEADING FEATURES / BENEFITS

Energy Efficiency

- 13.8 - 16.0 SEER2 / 11.2 - 13.0 EER2
- Levels as low as 65 dBA

Design Features

- Small footprint
- WeatherArmor cabinet
 - All steel cabinet construction
 - Mesh coil guard

Reliability, Quality and Toughness

- Scroll compressor
- Factory-supplied filter drier
- High pressure switch
- Line lengths up to 250ft (76.2m)
- Low ambient cooling (down to 0°F / -18°C) with approved low ambient accessory kits.

MODEL NUMBER NOMENCLATURE

1	2	3	4	5	6	7	8	9	10	11	12
N	N	A	A	A	N	N	N	A	A/N	A/N	N
3	4	S	C	A	5	1	8	W	0	0	3
Airflow Type / Refrigerant and OD Type		Outdoor Design Typey	Tier	Major Series	SEER2	Cooling Capacity 1,000 Btuh (nominal)		Region	Feature	Special Feature	Voltage
Horizontal Discharge / R410A AC		S = Single Stage	C=Comfort		5 =14.3 SEER2			W = Standard Southwest AC	0=Standard	0=Standard	3=208-230-1



Use of the AHRI Certified TM Mark indicates a manufacturer's participation in the program For verification of certification for individual products, go to www.ahridirectory.org

CATALOG ORDERING NUMBERS

Size	Model Number
18	34SCA518W003
24	34SCA524W003
30	34SCA530W003
36	34SCA536W003
48	34SCA548W003
60	34SCA560W003

PHYSICAL DATA

UNITSIZE	18	24	30	36	48	60
Compressor Type	Scroll					
REFRIGERANT	Puron® (R-410A)					
Charge lb (kg)	7.50 (3.40)	6.80 (3.08)	8.70 (3.95)	9.40 (4.26)	10.50 (4.76)	10.50 (4.76)
Cond Fan	Propeller Type, Direct Drive					
Air Discharge	Horizontal					
Air Qty (CFM)	1360	1530	1920	2615	2785	2785
Motor HP	1/3	1/3	1/10	1/4	1/4	1/3
Motor RPM	830	830	800	825	850	840
Cond Coil						
Face Area (Sq ft)	7.5	7.5	12.3	12.3	14.4	14.4
Fins per In.	20	20	20	20	20	20
Rows	2	2	2	2	2	2
Circuits	2	3	3	3	4	4
Valve Connect.(In.ID)						
Vapor	5/8	3/4	3/4	7/8	7/8	7/8
Liquid	3/8					
Refrigerant Tubes*(In.OD)						
Rated Vapor*	5/8	3/4	3/4	7/8	7/8	1-1/8
Max Liquid Line†	3/8					

* Units are rated with 25ft.(7.6m) of lineset length. Review the Vapor Line Sizing and Cooling Capacity Loss section when using other lineset sizes and lengths of lineset.

† Liquid Line Sizing For Cooling Only Systems with Puron® (R-410A) Refrigerant Tables.

Note: Review the unit's Installation Instructions for proper installation guidance.

REFRIGERANT PIPING LENGTH LIMITATIONS

Liquid Line Sizing and Maximum Total Equivalent Length[†] for Cooling Only Systems with Puron () Refrigerant:

The maximum allowable length of a residential split system depends on the liquid line diameter and vertical separation between the indoor and outdoor units. Review “Maximum Total Equivalent Length Outdoor Unit BELOW Indoor Unit,” for the liquid line sizing and maximum lengths.

Maximum Total Equivalent Length[†] Outdoor Unit BELOW Indoor Unit

SIZE	LIQUID LINE CONNECTION (IN.OD)	LIQUID LINE DIAM. W/TXV (IN. OD)	AC WITH Puron () REFRIGERANT MAXIMUM TOTAL EQUIVALENT LENGTH: OUTDOOR UNIT BELOW INDOOR VERTICAL SEPARATION FT (M)								
			0-5 (0-1.5)	6-10 (1.8-3.0)	11-20 (3.4-6.1)	21-30 (6.4-9.1)	31-40 (9.4-12.2)	41-50 (12.5-15.2)	51-60 (15.5-18.3)	61-70 (18.6-21.3)	71-80 (21.6-24.4)
18	3/8	1/4	150	150	125	100	100	75	--	--	--
		5/16	250*	250*	250*	250*	250*	250*	250*	225*	150
		3/8	250*	250*	250*	250*	250*	250*	250*	250*	250*
24	3/8	1/4	75	75	75	50	50	--	--	--	--
		5/16	250*	250*	250*	250*	250*	225*	175	125	100
		3/8	250*	250*	250*	250*	250*	250*	250*	250*	250*
30	3/8	1/4	30	--	--	--	--	--	--	--	--
		5/16	175	225*	200	175	125	100	75	--	--
		3/8	250*	250*	250*	250*	250*	250*	250*	250*	250*
36	3/8	5/16	175	150	150	100	100	100	75	--	--
		3/8	250*	250*	250*	250*	250*	250*	250*	250*	250*
48	3/8	3/8	250*	250*	250*	250*	250*	250*	230	160	--
60	3/8	3/8	250*	250*	250*	225*	190	150	110	--	--

* Maximum actual length not to exceed 200ft(61m)

† Total equivalent length accounts for losses due to elbows or fitting. See the Long Line Guideline for details.

--=outside acceptable range

Maximum Total Equivalent Length[†] Outdoor Unit ABOVE Indoor Unit

SIZE	LIQUID LINE CONNECTION (IN.OD)	LIQUID LINE DIAM.W/TXV (IN.OD)	AC WITH PURON () REFRIGERANT MAXIMUM TOTAL EQUIVALENT LENGTH: OUTDOOR UNIT ABOVE INDOOR VERTICAL SEPARATION ft. (m)								
			25 (7.6)	26-50 (7.9-15.2)	51-75 (15.5-22.9)	76-100 (23.2-30.5)	101-125 (30.8-38.1)	126-150 (38.4-45.7)	151-175 (46.0-53.3)	176-200 (53.6-61.0)	
018	3/8	1/4	175	250*	250*	250*	250*	250*	250*	250*	250*
		5/16	250*	250*	250*	250*	250*	250*	250*	250*	250*
		3/8	250*	250*	250*	250*	250*	250*	250*	250*	250*
024	3/8	1/4	100	125	175	200	225*	250*	250*	250*	250*
		5/16	250*	250*	250*	250*	250*	250*	250*	250*	250*
		3/8	250*	250*	250*	250*	250*	250*	250*	250*	250*
030	3/8	1/4	30	--	--	--	--	--	--	--	--
		5/16	250*	250*	250*	250*	250*	250*	250*	250*	250*
		3/8	250*	250*	250*	250*	250*	250*	250*	250*	250*
036	3/8	5/16	225*	250*	250*	250*	250*	250*	250*	250*	250*
		3/8	250*	250*	250*	250*	250*	250*	250*	250*	250*
048	3/8	3/8	250*	250*	250*	250*	250*	250*	250*	250*	250*
060	3/8	3/8	250*	250*	250*	250*	250*	250*	250*	250*	250*

* Maximum actual length not to exceed 200ft (61 m)

† Total equivalent length accounts for losses due to elbows or fitting. See “LONG-LINE APPLICATIONS” for details.

--=Outside acceptable range

REFRIGERANT CHARGE ADJUSTMENTS

LIQUID LINE SIZE (IN.OD)	R-410A CHARGE OZ/FT(G/M)
3/8	0.60(17.74) (Factory charge for lineset = 9 oz / 266.16 g)
5/16	0.40 (11.83)
1/4	0.27 (7.98)

Units are factory charged for 15 ft (4.6 m) of 3/8" liquid line. The factory charge for 3/8" lineset 9 oz (266.16 g). When using other length or diameter liquid lines, charge adjustments are required per the REFRIGERANT CHARGE ADJUSTMENTS table.

Charging Formula:

$[(\text{Lineset oz/ft} \times \text{total length}) - (\text{factory charge for lineset})] = \text{charge adjustment}$

Example 1: System has 15 ft of line set using existing 1/4 "liquid line. What charge adjustment is required?

Formula:

$(.27 \text{ oz/ft} \times 15\text{ft}) - (9 \text{ oz}) = (4.95) \text{ oz.}$

Net result is to remove 4.95 oz of refrigerant from the system

Example 2: System has 45 ft of existing 5/16" liquid line. What is the charge adjustment?

Formula:

$(.40 \text{ oz/ft.} \times 45\text{ft}) - (9 \text{ oz.}) = 9 \text{ oz.}$

Net result is to add 9 oz of refrigerant to the system

LONG LINE APPLICATIONS

An application is considered Long-Line, when the refrigerant level in the system requires the use of accessories to maintain acceptable refrigerant management for systems reliability. See ACCESSORY USAGE GUIDELINES for the required accessories.

Defining a system as long-line depends on the liquid line diameter, actual length of the tubing, and vertical separation between the indoor and outdoor units.

For air conditioner systems, the "AC WITH Puron REFRIGERANT LONG-LINE DESCRIPTION ft (m)" table shows when an application is considered long-line.

AC WITH PURON REFRIGERANT LONG LINE DESCRIPTION ft. (m)

Beyond these lengths, long line accessories are required

LIQUID LINE SIZE (IN.OD)	UNITS ON SAME LEVEL ft. (m)	OUTDOOR BELOW INDOOR ft. (m)	OUTDOOR ABOVE INDOOR ft. (m)
1/4	No accessories needed within allowed lengths	No accessories needed within allowed lengths	175(53)
5/16	120 (37)	50 (15.2) vertical or 120 (37) total	120 (37)
3/8	80 (24)	35 (10.7) vertical or 80(24) total	80 (24)

VAPOR LINE SIZING AND COOLING CAPACITY LOSS

LONG LINE APPLICATION: An application is considered “longline” when the total equivalent tubing length exceeds 80 ft. (24.4 m) or when there is more than 20 ft. (6.09 m) vertical separation between the indoor and outdoor units. These applications require additional accessories and system modifications for reliable system operation. The maximum allowable total equivalent length is up to 250 ft. (76.2 m).

The maximum vertical separation is 200 ft. (60.96 m) when the outdoor unit is above the indoor unit, and up to 80 ft. (24.4 m) when the outdoor unit is below the indoor unit. Refer to the ACCESSORY USAGE GUIDELINES or required accessories. See the Long-line Application Guideline for required piping and system modifications. Also, refer to the “Vapor Line Sizing and Cooling Capacity Losses — Puron Refrigerant 1-Stage Air Conditioner Applications” table for the vapor tube diameters based on the total length to minimize the cooling capacity loss.

Vapor Line Sizing and Cooling Capacity Losses — Puron Refrigerant 1-Stage Air Conditioner Applications

UNIT NOMINAL SIZE (BTUH)	MAXIMUM LIQUID LINE DIAMETERS (IN.OD)	VAPOR LINE DIAMETERS (IN.OD)	COOLING CAPACITY LOSS (%) TOTAL EQUIVALENT LINE LENGTH FT. (M)								
			26-50 (7.9-15.2)	51-80 (15.5-24.4)	81-100 (24.7-30.5)	101-125 (30.8-38.1)	126-150 (38.4-45.7)	151-175 (46.0-53.3)	176-200 (53.6-61.0)	201-225 (61.3-68.6)	226-250 (68.9-76.2)
018	3/8	1/2	1	2	3	5	6	7	8	9	11
		5/8	0	1	1	1	2	2	2	3	3
		3/4	0	0	0	0	1	1	1	1	1
024	3/8	5/8	0	1	2	2	3	3	4	5	5
		3/4	0	0	1	1	1	1	1	2	2
		7/8	0	0	0	0	0	1	1	1	1
030	3/8	5/8	1	2	3	3	4	5	6	7	8
		3/4	0	0	1	1	1	2	2	2	3
		7/8	0	0	0	0	1	1	1	1	1
036	3/8	5/8	1	2	4	5	6	8	9	10	12
		3/4	0	1	1	2	2	3	3	4	4
		7/8	0	0	0	1	1	1	1	2	2
048	3/8	3/4	0	1	2	3	4	5	5	6	7
		7/8	0	0	1	1	2	2	2	3	3
		1-1/8	0	0	0	0	0	0	0	1	1
060	3/8	3/4	1	2	4	5	6	7	9	10	11
		7/8	0	1	2	2	3	4	4	5	5
		1-1/8	0	0	0	1	1	1	1	1	1
= Applications in this area may be long-line and may have height restrictions. See LONG-LINE APPLICATIONS											

ACCESSORIES

KIT NUMBER	KIT NAME	UNIT SIZE (VOLTAGE / SERIES)					
		018	024	030	036	048	060
HC32GQ224	Fan Motor	X	X				
HC40GR228	Fan Motor						X
KAACH1701AAA	Crankcase Heater	X	X	X	X		
KAACH1601AAA	Crankcase Heater					X	X
KSAFT0101AAA	Evaporator Freeze Stat	X	X	X	X	X	X
KSACY0101AAA	Cycle Protector	X	X	X	X	X	X
KAATD0101TDR	Time Delay Relay	X	X	X	X	X	X
KAAWS0101AAA	Winter Start Kit	X	X	X	X	X	X
KSALA0801AAA	MotorMaster® 230v	X	X	X	X	X	X
KSAHS2501AAA	Hard Start Kit	X	X	X	X	X	X
53DS-900--087	Wind Baffle	X	X				
53DS-900--071	Wind Baffle			X	X		
53DS-900--088	Wind Baffle					X	X
53DS-900--075	Stacking Kit	X	X				
53DS-900--076	Stacking Kit			X	X	X	X
53DS-900--077	Wall Mounting Kit	X	X				
53DS-900--078	Wall Mounting Kit			X	X	X	X
KAALP0401PUR	Low Pressure Switch Kit	X	X	X	X	X	X
KSASH2301COP	Sound Blanket Kit	X	X	X	X		
KSASH2401COP	Sound Blanket Kit					X	X
KAALS0201LLS	Solenoid Valve Kit	X	X	X	X	X	X
KSALA0301410	Low Ambient Kit	X	X	X	X	X	X
KSATX0201PUR	TXV Kit	X	X	X			
KSBTX0201PUR	TXV Kit	X	X	X			
KSATX0301PUR	TXV Kit				X		
KSBTX0301PUR	TXV Kit				X		
KSATX401PUR	TXV Kit					X	X
KSBTX401PUR	TXV Kit					X	X

X=Accessory

ACCESSORY USAGE GUIDELINE

ACCESSORY	REQUIRED FOR LOW-AMBIENT COOLING APPLICATIONS (BELOW 55° F/12.8° C)	REQUIRED FOR LONG LINE APPLICATIONS* (Over 80 ft./24.38 m)	REQUIRED FOR SEA COAST APPLICATIONS (WITHIN 2 MILES / 3.22 km)
Ball Bearing Fan Motor	Standard	Standard	Standard
Compressor Start Assist Capacitor and Relay	Yes	Yes	No
Crankcase Heater	Yes	Yes	No
Evaporator Freeze Thermostat	Yes	No	No
Liquid Line Solenoid Valve	No	See Long Line Application Guideline	No
MotorMaster® Controller or Low-ambient Pressure Switch	Yes†	No	No
Winter Start Control	Yes‡	No	No

*. For tubing line sets between 80 and 200 ft. (24.38 and 60.96 m) and/or 20 ft. (6.09 m) vertical differential, refer to Residential Split-System Long line Application Guideline.

†. In units equipped with ECM OD motor, motor and fan needs to be replaced per unit accessory guide to work properly. Unit will not meet AHRI rated efficiency once motor and fan are replaced to use this accessory.

‡. Required if Low Pressure Switch is factory or field installed.

ACCESSORY DESCRIPTION AND USAGE

1. Ball-Bearing Fan Motor

A fan motor with ball bearings that permits speed reduction while maintaining bearing lubrication.

Usage Guideline:

Required on all units when using MotorMaster®

2. Compressor Start Assist – Capacitor and Relay

Start capacitor and relay gives a “hard” boost to compressor motor at each start-up.

Usage Guideline:

Required for reciprocating compressors in the following applications:

- Long line
- Low ambient cooling
- Hard shut off expansion valve on indoor coil
- Liquid line solenoid on indoor coil

Required for single-phase scroll compressors in the following applications:

- Long line
- Low ambient cooling

Suggested for all compressors in areas with a history of low voltage problems.

3. Crankcase Heater

An electric resistance heater which mounts to the base of the compressor to keep the lubricant warm during off cycles. Improves compressor lubrication on restart and minimizes the chance of liquid slugging.

Usage Guideline:

- Required in low ambient cooling applications.
- Required in long line applications.
- Suggested in all commercial applications.

4. Evaporator Freeze Thermostat

An SPST temperature-actuated switch that stops unit operation when the evaporator reaches freeze-up conditions.

Usage Guideline:

Required when a low ambient kit has been added.

5. Low Pressure Switch Kit

Optional added compressor protection against loss of refrigerant. The compressor cuts out the system at 50 PSI and allows operation again at 95 PSI. Used for commercial or “harsh” environment applications for extra protection. Not required for a Low-Ambient Cooling application.

6.6. MotorMaster® Low-Ambient Controller

A fan-speed control device activated by a temperature sensor, designed to control condenser fan motor speed in response to the saturated, condensing temperature during operation in cooling mode only. For outdoor temperatures down to -10°F/-23.3°C, it maintains condensing temperature at 100°F ±10°F (37.8°C ±5.5°C).

Usage Guideline:

A MotorMaster® Low Ambient Controller or Low-Ambient Pressure Switch must be used when cooling operation is used at outdoor temperatures below 55°F (12.8°C).

Suggested for all commercial applications.

7.7. Winter Start Kit

The device is designed to alleviate nuisance opening of the low-pressure switch by bypassing it for the first 3 minutes of operation. A Winter Start control must be used where low evaporator temperatures, or nuisance tripping of low-pressure switch may be encountered. It is not required for low ambient cooling applications unless a low-pressure switch is added.

8. Time Delay Relay

Optional accessory for systems that do not have an integral blower time delay.

ELECTRICAL DATA

UNITSIZE	V/PH	OPER VOLTS†		COMPR		FAN	MCA	MAX FUSE†OR CKT BRK AMPS
		MAX	MIN	LRA	RLA	FLA		
18	208-230/1	253	197	42.6	8.80	2.60	13.6	20
24				49.7	9.30	2.60	14.2	20
30				65.0	12.80	0.70	16.7	25
36				80.1	12.20	1.20	16.5	25
48				110.0	19.90	1.45	26.4	40
60				150.0	25.60	2.60	34.6	50

* Permissible limits of the voltage range at which the unit operates satisfactorily

† Time-Delay fuse.

Complies with 2023 requirements of ASHRAE Standards 90.1

LEGEND:**FLA** - Full Load Amps**HACR** - Heating, Air Conditioning, Refrigeration**LRA** - Locked Rotor Amps**NEC** - National Electrical Code**RLA** - Rated Load Amps (compressor)**SOUND POWER LEVEL**

UNIT SIZE	STANDARD RATING(dBA)	TYPICAL OCTAVE BAND SPECTRUM (dB, WITHOUT TONE ADJUSTMENT)							
		125	250	500	1000	2000	4000	8000	
18	67	65.7	62.8	60.9	62.1	61.9	55.7	49.3	
24	70	72.8	66.2	66.8	67.4	60.7	56.6	49.5	
30	69	73.2	68.0	66.1	63.4	62.2	58.6	54.2	
36	71	70.6	67.7	65.9	66.1	63.4	60.2	56.1	
48	73	68.0	70.1	69.6	66.5	64.3	65.1	60.0	
60	73	74.7	71.9	68.5	67.9	63.0	61.3	60.8	

NOTE:Tested in compliance with AHRI 270 but not listed with AHRI..

SOUND POWER LEVEL WITH ACCESSORY SOUND SHIELD

UNITSIZE	STANDARD RATING (dBA)	TYPICAL OCTAVE BAND SPECTRUM (dB, WITHOUT TONE ADJUSTMENT)							
		125	250	500	1000	2000	4000	8000	
18	65	67.7	63.0	59.6	59.6	58.8	53.3	47.7	
24	67	69.8	65.0	63.5	62.7	58.2	54.6	46.5	
30	69	73.4	67.8	65.7	63.3	61.6	58.2	53.2	
36	70	70.6	67.5	65.5	66.2	63.0	59.6	55.0	
48	73	68.2	69.9	69.6	66.4	64.4	65.4	60.4	
60	73	75.5	72.9	69.3	67.2	62.6	60.7	60.0	

NOTE:Tested in compliance with AHRI 270 but not listed with AHRI..

SOUND PRESSURE LEVELS (dBA)

UNITSIZE	AT DISTANCE 10' FROM UNIT	AT DISTANCE 15' FROM UNIT	AT DISTANCE 20' FROM UNIT
18	51.5	48.0	45.5
24	48.5	45.0	42.5
30	50.5	47.0	44.5
36	53.5	50.0	47.5
48	52.5	49.0	46.5
60	55.5	52.0	49.5

NOTE: Sound pressure data vs distance converted using AHRI 275 Standard under certain environmental and layout assumptions

CHARGING SUB-COOLING (TXV-TYPE EXPANSION DEVICE)

UNITSIZE-SERIES	REQUIRESUBCOOLING°F(°C)
18	12 (6.7)
24	11 (6.1)
30	8 (4.4)
36	8 (4.4)
48	13 (7.2)
60	12 (6.7)

Manufacturer reserves the right to change, at any time, specifications and designs without notice and without obligations.

DIMENSIONS - ENGLISH

UNIT	SERIES	ELECTRICAL CHARACTERISTICS					A	B	C	D	E	F	G	H	J	K	L	M	N	P	OPERATING WEIGHT(lbs)	SHIPPING WEIGHT(lbs)	SHIPPING DIMENSIONS (L x W x H)
34SCA518	0	Y	N	N	N	31 1/8"	36 15/16"	14 9/16"	16"	23 7/16"	17 3/16"	23 1/8"	28 1/16"	15 1/2"	6 1/4"	14 1/2"	5/8"	2 7/8"	5 13/16"	153	171	42 15/16" X 18" X 34 1/8"	
34SCA524	0	Y	N	N	N	31 1/8"	36 15/16"	14 9/16"	16"	23 7/16"	17 3/16"	23 1/8"	28 1/16"	15"	6 1/2"	13"	3/4"	2 7/8"	5 13/16"	156	174	42 15/16" X 18" X 34 1/8"	
34SCA530	0	Y	N	N	N	37 1/8"	44 1/2"	17 1/16"	18 7/16"	30 1/2"	19 5/8"	29 1/8"	34 1/16"	18"	7 3/4"	16 3/4"	3/4"	3 3/8"	6 3/8"	189	212	50 1/2" X 20 1/2" X 40 1/8"	
34SCA536	0	Y	N	N	N	37 1/8"	44 1/2"	17 1/16"	18 7/16"	30 1/2"	19 5/8"	29 1/8"	34 1/16"	19"	8 1/2"	15 3/4"	7/8"	3 3/8"	6 3/8"	191	214	50 1/2" X 20 1/2" X 40 1/8"	
34SCA548	0	Y	N	N	N	43 1/8"	44 1/2"	17 1/16"	18 7/16"	30 1/2"	19 5/8"	35 1/8"	40 1/16"	18"	9 1/2"	17 1/2"	7/8"	3 3/8"	6 3/8"	243	265	50 1/2" X 20 1/2" X 46 1/8"	
34SCA560	0	Y	N	N	N	43 1/8"	44 1/2"	17 1/16"	18 7/16"	30 1/2"	19 5/8"	35 1/8"	40 1/16"	18 1/2"	8 1/2"	18"	7/8"	3 3/8"	6 3/8"	237	260	50 1/2" X 20 1/2" X 46 1/8"	

208-230-1-60	230-1-60	208/230-3-60	460-3-60
--------------	----------	--------------	----------

Y=YES
N=NO

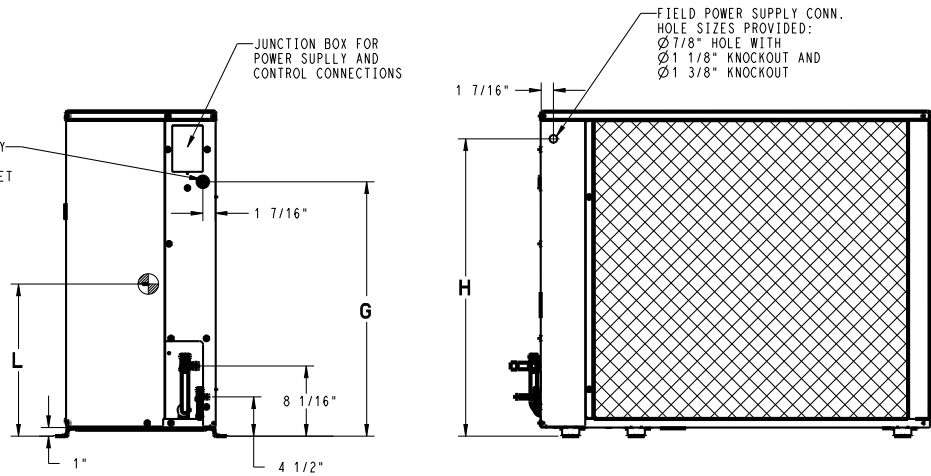
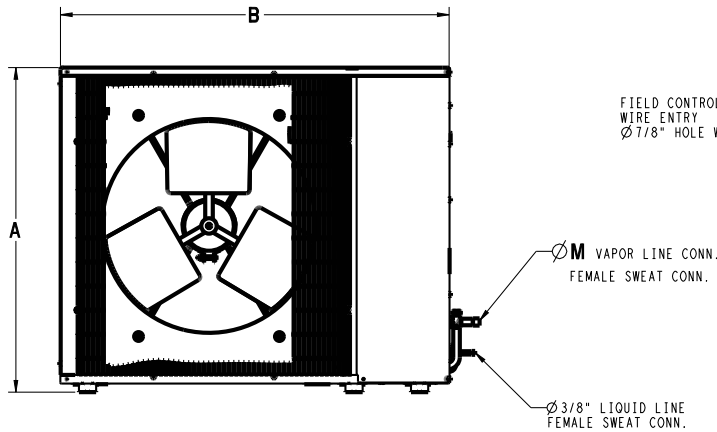
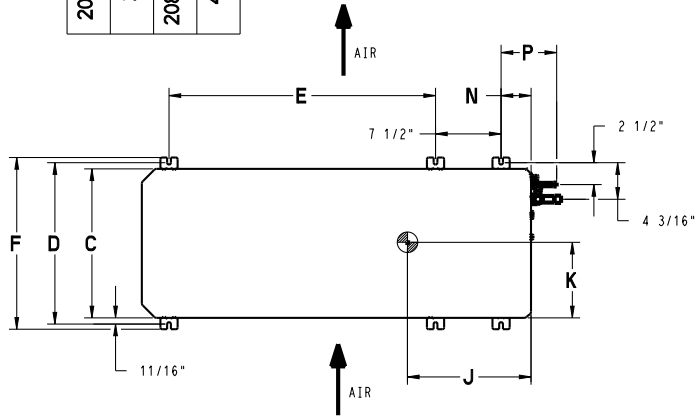

1. CLEARANCE REQUIREMENTS: SINGLE UNIT APPLICATIONS: WITH COIL FACING WALL: ALLOW 6 IN. MINIMUM CLEARANCE ON COIL SIDE AND COIL END AND 20 IN. MINIMUM CLEARANCE ON FAN SIDE. WITH FAN FACING WALL: ALLOW 8 IN. MINIMUM CLEARANCE ON FAN SIDE AND 6 IN. ON COIL END AND 20 IN. MINIMUM CLEARANCE ON COIL SIDE. MULTI-UNIT APPLICATIONS: ALLOW 24 IN. MINIMUM CLEARANCE BETWEEN FAN AND COIL SIDES OF MULTIPLE UNITS. ARRANGE UNITS SO DISCHARGE OF ONE DOES NOT ENTER INLET OF ANOTHER WHEN TWO UNITS ARE INSTALLED END TO END WITH THE COIL ENDS FACING EACH OTHER ALLOW 12 IN. MINIMUM CLEARANCE BETWEEN UNITS. COMPRESSOR END SERVICE CLEARANCE: ALLOW 24 IN. MINIMUM CLEARANCE ON COMPRESSOR END WHEN UNITS ARE STACKED OR THERE IS LESS THAN 40 IN. OF CLEARANCE ABOVE THE TOP OF THE UNIT. IF THERE IS 40 IN. CLEARANCE ABOVE UNIT AND THE TOP PANEL IS ACCESSIBLE FOR REMOVAL ALLOW 8 IN. MINIMUM CLEARANCE ON COMPRESSOR END FOR SERVICE. IMPORTANT: WHEN INSTALLING SINGLE OR MULTIPLE UNITS IN AN ALCOVE, ROOF WELL, OR PARTIALLY ENCLOSED AREA, ENSURE THERE IS ADEQUATE VENTILATION TO PREVENT RECIRCULATION OF DISCHARGE AIR.
2. MINIMUM OUTDOOR OPERATING AMBIENT IN COOLING MODE IS 55°F, MAX. 125°F.
3. SERIES DESIGNATION IS THE 13TH POSITION OF THE UNIT MODEL NUMBER.
4. CENTER OF GRAVITY
5. ALL DIMENSIONS ARE IN "INCHES" UNLESS NOTED.

UNIT SIZE	MINIMUM MOUNTING PAD DIMENSIONS
18,24	23" X 42"
30,36,48,60	24" X 50"

NOTE: ALL DIMENSIONS IN INCH

U.S. ECCN: Not Subject to Regulation (N.S.R)

DIMENSIONS - SI

UNIT	SERIES	ELECTRICAL CHARACTERISTICS					A	B	C	D	E	F	G	H	J	K	L	M	N	P	OPERATING WEIGHT(KG)	SHIPPING WEIGHT(KG)	SHIPPING DIMENSIONS (L x W x H)
34SCA518	0	Y	N	N	N	790.4	938.0	370.0	406.0	595.5	436.0	587.6	712.2	393.7	158.8	368.3	15.9	73.0	148.2	69.4	77.6	1090.2 X 457.7 X 866.7	
34SCA524	0	Y	N	N	N	790.4	938.0	370.0	406.0	595.5	436.0	587.6	712.2	381.0	165.1	330.2	19.1	73.0	148.2	70.8	78.9	1090.2 X 457.7 X 866.7	
34SCA530	0	Y	N	N	N	942.8	1130.0	433.0	469.0	774.5	499.0	740.0	864.6	457.2	196.9	425.5	19.1	86.0	161.2	85.7	96.2	1282.7 X 520.7 X 1019.1	
34SCA536	0	Y	N	N	N	942.8	1130.0	433.0	469.0	774.5	499.0	740.0	864.6	482.6	215.9	400.1	22.2	86.0	161.2	86.6	97.1	1282.7 X 520.7 X 1019.1	
34SCA548	0	Y	N	N	N	1095.2	1130.0	433.0	469.0	774.5	499.0	892.4	1017.0	457.2	241.3	444.5	22.2	86.0	161.2	110.2	120.2	1282.7 X 520.7 X 1171.5	
34SCA560	0	Y	N	N	N	1095.2	1130.0	433.0	469.0	774.5	499.0	892.4	1017.0	469.9	215.9	457.2	22.2	86.0	161.2	107.5	117.9	1282.7 X 520.7 X 1171.5	

208-230-160
230-160
208/230-3-60
460-3-60

Y=YES
N=NO

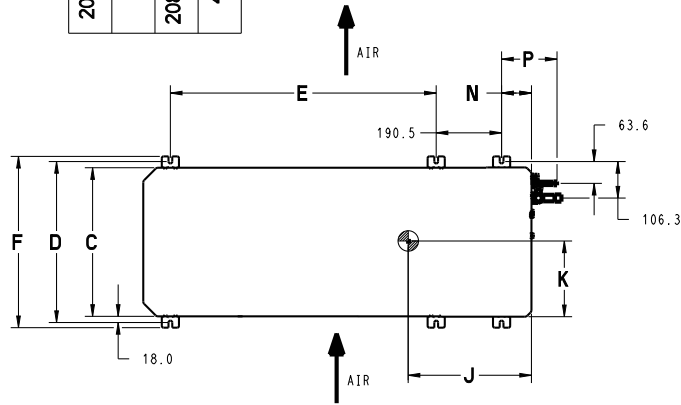

- CLEARANCE REQUIREMENTS: SINGLE UNIT APPLICATIONS: WITH COIL FACING WALL: ALLOW 152.4 mm MINIMUM CLEARANCE ON COIL SIDE AND COIL END AND 504 mm MINIMUM CLEARANCE ON FAN SIDE. WITH FAN FACING WALL: ALLOW 203.2 mm MINIMUM CLEARANCE ON FAN SIDE AND 152.4 mm ON COIL END AND 504.0 mm MINIMUM CLEARANCE ON COIL SIDE. MULTI-UNIT APPLICATIONS: ALLOW 609.6 mm MINIMUM CLEARANCE BETWEEN FAN AND COIL SIDES OF MULTIPLE UNITS. ARRANGE UNITS SO DISCHARGE OF ONE DOES NOT ENTER INLET OF ANOTHER WHEN TWO UNITS ARE INSTALLED END TO END WITH THE COIL ENDS FACING EACH OTHER ALLOW 304.8 mm MINIMUM CLEARANCE BETWEEN UNITS. COMPRESSOR END SERVICE CLEARANCE: ALLOW 609.6 mm MINIMUM CLEARANCE ON COMPRESSOR END WHEN UNITS ARE STACKED OR THERE IS LESS THAN 1016 mm OF CLEARANCE ABOVE THE TOP OF THE UNIT. IF THERE IS 1016 mm CLEARANCE ABOVE UNIT AND THE TOP PANEL IS ACCESSIBLE FOR REMOVAL ALLOW 203.2 mm MINIMUM CLEARANCE ON COMPRESSOR END FOR SERVICE.

IMPORTANT: WHEN INSTALLING SINGLE OR MULTIPLE UNITS IN AN ALCOVE, ROOF WELL, OR PARTIALLY ENCLOSED AREA, ENSURE THERE IS ADEQUATE VENTILATION TO PREVENT RECIRCULATION OF DISCHARGE AIR.

- MINIMUM OUTDOOR OPERATING AMBIENT IN COOLING MODE IS 12.8°C, MAX. 51.7°C.
- SERIES DESIGNATION IS THE 13TH POSITION OF THE UNIT MODEL NUMBER.
- CENTER OF GRAVITY
- ALL DIMENSIONS ARE IN "MM" UNLESS NOTED.

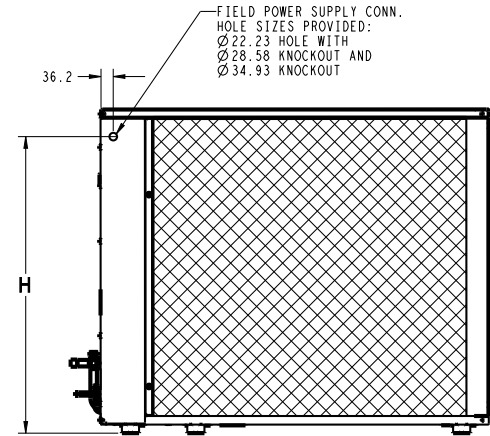
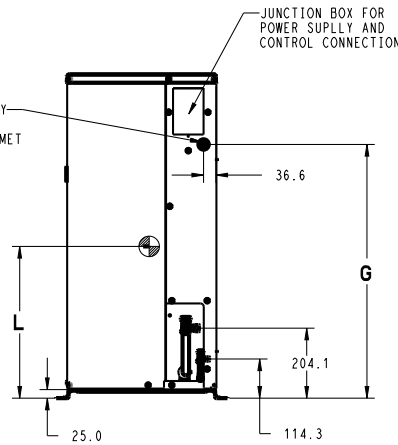
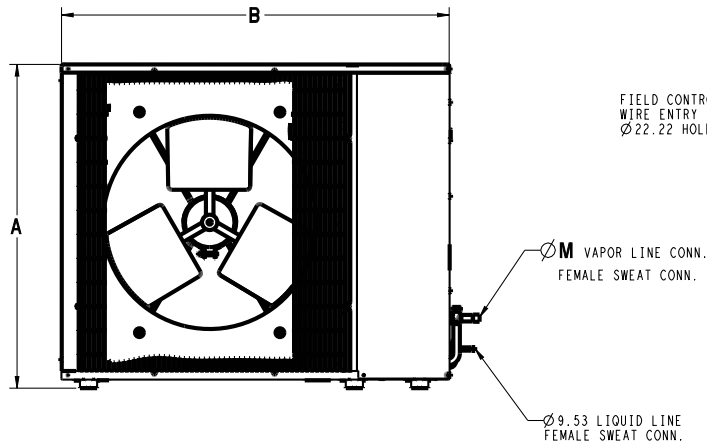

UNIT SIZE	MINIMUM MOUNTING PAD DIMENSIONS
18,24	584.2 X 1066.8
30,36,48,60	609.6 X 1270.0

NOTE: ALL DIMENSIONS IN METRIC

U.S. ECCN: Not Subject to Regulation (N.S.R)

ESTED AHRI COMBINATION RATINGS

NOTE: Ratings contained in this document are subject to change at any time.

For AHRI ratings certificates, please refer to the AHRI directory www.ahridirectory.org

Additional ratings and system combinations can be accessed via the Ratings Database here: www.MyCarrierRatings.com

Outdoor Model Number	Indoor Coil Model Number	Capacity	EER2	SEER2
34SCA518W003	CAP**1917AL*+TDR	18,000	12.5	14.3
34SCA524W003	CAP**2517AL*+TDR	23,800	12.5	14.3
34SCA530W003	CAP**3721AL*+TDR	28,400	12.0	14.3
34SCA536W003	CAP**3721AL*+TDR	35,600	12.5	14.5
34SCA548W003	CAP**6124AL*+TDR	47,500	12.0	14.0
34SCA560W003	CAP**6124AL*+TDR	57,000	11.5	13.8

EER2—Energy Efficiency Ratio

SEER2—Seasonal Energy Efficiency Ratio

TXV—Thermostatic Expansion Valve

NOTES:

1. Ratings are net values reflecting the effects of circulating fan motor heat. Supplemental electric heat is not included.
2. Tested outdoor/indoor combinations have been tested in accordance with DOE test procedures for central air conditioners. Ratings for other combinations are determined under DOE computer simulation procedures.
3. Determine actual CFM values obtainable for your system by referring to fan performance data in the fan coil or furnace coil literature.
4. Do not apply with capillary tube coils as performance and reliability are significantly affected.

DETAILED COOLING CAPACITIES

EVAPORATOR AIR		CONDENSER ENTERING AIR TEMPERATURES °F (°C)																	
		75.0 (23.9)			85.0 (29.4)			95.0 (35.0)			105.0 (40.6)			115.0 (46.1)			125.0 (51.7)		
		CFM	EWB	Capacity MBtu/h†		Total System kW**	Capacity MBtu/h†		Total System kW**	Capacity MBtu/h†		Total System kW**	Capacity MBtu/h†		Total System kW**	Capacity MBtu/h†		Total System kW**	Capacity MBtu/h†
Total	Sens‡			Total	Sens‡		Total	Sens‡		Total	Sens‡		Total	Sens‡		Total	Sens‡		Total
34SCA518W003 Outdoor Section With CAP**1917AL* Indoor Section																			
525	72.0 (22.2)	21.60	10.69	1.13	20.63	10.35	1.26	19.60	9.99	1.41	18.48	9.61	1.57	17.27	9.20	1.76	15.95	8.76	1.98
	67.0 (19.4)	19.54	13.11	1.13	18.65	12.77	1.26	17.70	12.40	1.41	16.68	12.02	1.57	15.58	11.61	1.76	14.37	11.16	1.97
	63.0 (17.2)††	18.08	12.59	1.13	17.24	12.24	1.26	16.36	11.88	1.41	15.41	11.49	1.57	14.36	11.07	1.75	13.26	10.64	1.97
	62.0 (16.7)	17.71	15.48	1.13	16.90	15.13	1.26	16.05	14.75	1.41	15.20	15.20	1.57	14.39	14.39	1.76	13.49	13.49	1.97
	57.0 (13.9)	17.22	17.22	1.13	16.59	16.59	1.26	15.91	15.91	1.41	15.18	15.18	1.57	14.37	14.37	1.76	13.47	13.47	1.97
600	72.0 (22.2)	22.01	11.29	1.16	21.00	10.94	1.29	19.92	10.57	1.44	18.75	10.18	1.61	17.49	9.77	1.80	16.12	9.32	2.01
	67.0 (19.4)	19.92	14.06	1.16	18.99	13.71	1.29	18.00	13.34	1.44	16.94	12.94	1.61	15.79	12.52	1.79	14.56	12.06	2.00
	63.0 (17.2)††	18.44	13.47	1.16	17.58	13.12	1.29	16.65	12.74	1.44	15.66	12.35	1.60	14.59	11.93	1.79	13.43	11.47	2.00
	62.0 (16.7)	18.13	16.73	1.17	17.36	17.36	1.29	16.63	16.63	1.44	15.84	15.84	1.60	14.96	14.96	1.79	14.00	14.00	2.00
	57.0 (13.9)	18.01	18.01	1.17	17.33	17.33	1.29	16.60	16.60	1.44	15.81	15.81	1.60	14.94	14.94	1.79	13.98	13.98	2.00
675	72.0 (22.2)	22.29	11.86	1.19	21.25	11.51	1.32	20.13	11.14	1.47	18.93	10.75	1.64	17.62	10.33	1.83	16.22	9.88	2.04
	67.0 (19.4)	20.20	14.98	1.20	19.24	14.62	1.33	18.22	14.24	1.47	17.13	13.84	1.64	15.95	13.41	1.83	14.68	12.94	2.04
	63.0 (17.2)††	18.71	14.33	1.20	17.82	13.97	1.33	16.86	13.58	1.47	15.84	13.18	1.64	14.74	12.74	1.82	13.56	12.26	2.03
	62.0 (16.7)	18.71	18.71	1.20	17.98	17.98	1.33	17.20	17.20	1.47	16.36	16.36	1.64	15.43	15.43	1.83	14.41	14.41	2.04
	57.0 (13.9)	18.68	18.68	1.20	17.95	17.95	1.33	17.18	17.18	1.47	16.34	16.34	1.64	15.41	15.41	1.83	14.39	14.39	2.04
34SCA524W003 Outdoor Section With CAP**2517AL* Indoor Section																			
700	72.0 (22.2)	28.85	14.36	1.53	27.47	13.88	1.71	25.99	13.38	1.91	24.42	12.84	2.14	22.75	12.28	2.38	20.98	11.70	2.66
	67.0 (19.4)	26.42	17.80	1.54	25.15	17.31	1.71	23.80	16.80	1.90	22.36	16.26	2.12	20.83	15.69	2.36	19.21	15.09	2.64
	63.0 (17.2)††	24.67	17.19	1.54	23.48	16.69	1.71	22.22	16.18	1.90	20.88	15.63	2.11	19.45	15.06	2.35	17.93	14.45	2.62
	62.0 (16.7)	24.22	21.15	1.54	23.06	20.64	1.70	21.85	20.09	1.89	20.67	20.67	2.11	19.51	19.51	2.35	18.25	18.25	2.62
	57.0 (13.9)	23.62	23.62	1.54	22.70	22.70	1.70	21.71	21.71	1.89	20.64	20.64	2.11	19.48	19.48	2.35	18.23	18.23	2.62
800	72.0 (22.2)	29.27	15.14	1.57	27.82	14.65	1.76	26.29	14.14	1.96	24.66	13.60	2.18	22.93	13.03	2.43	21.11	12.45	2.71
	67.0 (19.4)	26.84	19.06	1.58	25.51	18.56	1.76	24.11	18.03	1.95	22.62	17.48	2.17	21.03	16.90	2.41	19.37	16.29	2.68
	63.0 (17.2)††	25.08	18.35	1.58	23.86	17.85	1.75	22.53	17.32	1.94	21.14	16.76	2.16	19.66	16.18	2.40	18.10	15.56	2.67
	62.0 (16.7)	24.73	24.73	1.58	23.63	23.63	1.75	22.56	22.56	1.94	21.41	21.41	2.16	20.16	20.16	2.40	18.82	18.82	2.68
	57.0 (13.9)	24.59	24.59	1.58	23.60	23.60	1.75	22.53	22.53	1.94	21.38	21.38	2.16	20.14	20.14	2.40	18.80	18.80	2.68
900	72.0 (22.2)	29.55	15.89	1.62	28.05	15.40	1.80	26.48	14.88	2.01	24.80	14.34	2.23	23.04	13.78	2.48	21.17	13.18	2.75
	67.0 (19.4)	27.13	20.27	1.62	25.76	19.77	1.80	24.32	19.23	2.00	22.79	18.67	2.22	21.18	18.07	2.46	19.48	17.43	2.73
	63.0 (17.2)††	25.39	19.48	1.63	24.11	18.97	1.80	22.76	18.43	1.99	21.33	17.86	2.20	19.82	17.26	2.45	18.24	16.60	2.72
	62.0 (16.7)	25.43	25.43	1.63	24.36	24.36	1.80	23.23	23.23	1.99	22.00	22.00	2.21	20.68	20.68	2.46	19.27	19.27	2.73
	57.0 (13.9)	25.39	25.39	1.63	24.33	24.33	1.80	23.20	23.20	1.99	21.98	21.98	2.21	20.66	20.66	2.46	19.24	19.24	2.73

Manufacturer reserves the right to change, at any time, specifications and designs without notice and without obligations.

DETAILED COOLING CAPACITIES (Continued)

EVAPORATOR AIR		CONDENSER ENTERING AIR TEMPERATURES °F (°C)																	
		75.0 (23.9)			85.0 (29.4)			95.0 (35.0)			105.0 (40.6)			115.0 (46.1)			125.0 (51.7)		
		Capacity MBtu/h†		Total System kW**	Capacity MBtu/h†		Total System kW**	Capacity MBtu/h†		Total System kW**	Capacity MBtu/h†		Total System kW**	Capacity MBtu/h†		Total System kW**	Capacity MBtu/h†		Total System kW**
CFM	EWB	Total	Sens‡	Total System kW**	Total	Sens‡	Total System kW**	Total	Sens‡	Total System kW**	Total	Sens‡	Total System kW**	Total	Sens‡	Total System kW**	Total	Sens‡	Total System kW**
		34SCA530W003 Outdoor Section With CAP**3721AL* Indoor Section																	
875	72.0 (22.2)	34.11	17.19	1.92	32.54	16.64	2.11	30.84	16.06	2.32	28.98	15.43	2.56	26.96	14.76	2.84	24.80	14.05	3.15
	67.0 (19.4)	30.98	21.28	1.91	29.55	20.74	2.09	28.01	20.15	2.31	26.36	19.53	2.55	24.52	18.84	2.82	22.56	18.12	3.14
	63.0 (17.2)††	28.76	20.46	1.90	27.45	19.91	2.09	26.03	19.33	2.30	24.49	18.71	2.54	22.80	18.03	2.81	20.98	17.31	3.13
	62.0 (16.7)	28.26	25.27	1.90	26.99	24.69	2.09	25.68	25.68	2.30	24.44	24.44	2.54	23.05	23.05	2.82	21.54	21.54	3.13
	57.0 (13.9)	27.76	27.76	1.90	26.74	26.74	2.08	25.63	25.63	2.30	24.40	24.40	2.54	23.02	23.02	2.82	21.51	21.51	3.13
1000	72.0 (22.2)	34.64	18.15	1.98	33.00	17.60	2.17	31.22	17.01	2.38	29.30	16.37	2.62	27.19	15.69	2.90	24.97	14.97	3.21
	67.0 (19.4)	31.49	22.81	1.97	30.00	22.25	2.15	28.40	21.65	2.37	26.68	21.01	2.61	24.78	20.31	2.89	22.76	19.57	3.20
	63.0 (17.2)††	29.26	21.87	1.96	27.90	21.32	2.15	26.43	20.73	2.36	24.81	20.08	2.60	23.06	19.39	2.87	21.19	18.64	3.19
	62.0 (16.7)	28.98	28.98	1.96	27.87	27.87	2.15	26.66	26.66	2.36	25.33	25.33	2.60	23.84	23.84	2.88	22.22	22.22	3.20
	57.0 (13.9)	28.93	28.93	1.96	27.83	27.83	2.15	26.62	26.62	2.36	25.29	25.29	2.60	23.81	23.81	2.88	22.20	22.20	3.20
1125	72.0 (22.2)	35.01	19.09	2.04	33.31	18.53	2.23	31.48	17.93	2.44	29.49	17.28	2.68	27.33	16.59	2.96	25.05	15.86	3.27
	67.0 (19.4)	31.87	24.30	2.03	30.34	23.73	2.21	28.68	23.12	2.43	26.92	22.46	2.67	24.97	21.73	2.94	22.93	20.92	3.26
	63.0 (17.2)††	29.62	23.25	2.02	28.20	22.68	2.21	26.69	22.07	2.42	25.04	21.41	2.66	23.26	20.68	2.93	21.38	21.38	3.25
	62.0 (16.7)	29.95	29.95	2.02	28.77	28.77	2.21	27.47	27.47	2.42	26.06	26.06	2.66	24.48	24.48	2.94	22.77	22.77	3.26
	57.0 (13.9)	29.91	29.91	2.02	28.73	28.73	2.21	27.44	27.44	2.42	26.03	26.03	2.66	24.45	24.45	2.94	22.74	22.74	3.26
34SCA536W003 Outdoor Section With CAP**3721AL* Indoor Section																			
1050	72.0 (22.2)	42.99	21.55	2.31	40.91	20.83	2.54	38.67	20.06	2.80	36.23	19.24	3.09	33.57	18.36	3.43	30.71	17.42	3.82
	67.0 (19.4)	39.16	26.67	2.31	37.28	25.94	2.54	35.27	25.18	2.80	33.08	24.35	3.09	30.69	23.47	3.43	28.10	22.51	3.82
	63.0 (17.2)††	36.37	25.64	2.30	34.64	24.93	2.55	32.80	24.17	2.80	30.80	23.36	3.09	28.60	22.47	3.43	26.20	21.52	3.82
	62.0 (16.7)	35.76	31.63	2.30	34.11	30.88	2.54	32.38	32.38	2.80	30.70	30.70	3.09	28.89	28.89	3.43	26.88	26.88	3.82
	57.0 (13.9)	35.04	35.04	2.30	33.71	33.71	2.54	32.26	32.26	2.80	30.65	30.65	3.09	28.85	28.85	3.43	26.85	26.85	3.82
1150	72.0 (22.2)	43.45	22.35	2.35	41.30	21.62	2.58	38.99	20.84	2.84	36.48	20.01	3.13	33.76	19.11	3.47	30.84	18.16	3.87
	67.0 (19.4)	39.61	27.93	2.35	37.67	27.19	2.59	35.60	26.42	2.85	33.35	25.58	3.14	30.90	24.67	3.48	28.26	23.69	3.87
	63.0 (17.2)††	36.81	26.82	2.35	35.05	26.10	2.59	33.14	25.32	2.85	31.07	24.49	3.14	28.82	23.59	3.47	26.38	22.62	3.86
	62.0 (16.7)	36.34	33.28	2.35	34.79	34.79	2.59	33.17	33.17	2.85	31.46	31.46	3.14	29.56	29.56	3.47	27.45	27.45	3.87
	57.0 (13.9)	36.07	36.07	2.35	34.65	34.65	2.59	33.12	33.12	2.85	31.42	31.42	3.14	29.52	29.52	3.47	27.41	27.41	3.87
1350	72.0 (22.2)	44.08	23.87	2.44	41.83	23.12	2.67	39.42	22.33	2.93	36.81	21.48	3.22	33.98	20.57	3.56	30.97	19.60	3.96
	67.0 (19.4)	40.27	30.37	2.44	38.25	29.62	2.68	36.08	28.81	2.94	33.75	27.95	3.23	31.22	27.00	3.57	28.52	25.93	3.96
	63.0 (17.2)††	37.47	29.09	2.44	35.61	28.34	2.68	33.62	27.54	2.94	31.49	26.65	3.23	29.15	25.73	3.57	26.61	26.61	3.95
	62.0 (16.7)	37.82	37.82	2.44	36.25	36.25	2.68	34.56	34.56	2.94	32.69	32.69	3.23	30.62	30.62	3.57	28.33	28.33	3.96
	57.0 (13.9)	37.76	37.76	2.44	36.21	36.21	2.68	34.52	34.52	2.94	32.65	32.65	3.23	30.58	30.58	3.57	28.30	28.30	3.96

Manufacturer reserves the right to change, at any time, specifications and designs without notice and without obligations.

DETAILED COOLING CAPACITIES (Continued)

EVAPORATOR AIR		CONDENSER ENTERING AIR TEMPERATURES °F (°C)																	
		75.0 (23.9)			85.0 (29.4)			95.0 (35.0)			105.0 (40.6)			115.0 (46.1)			125.0 (51.7)		
		Capacity MBtu/h†		Total System kW**	Capacity MBtu/h†		Total System kW**	Capacity MBtu/h†		Total System kW**	Capacity MBtu/h†		Total System kW**	Capacity MBtu/h†		Total System kW**	Capacity MBtu/h†		Total System kW**
Total	Sens‡	Total	Sens‡		Total	Sens‡		Total	Sens‡		Total	Sens‡		Total	Sens‡		Total	Sens‡	
34SCA548W003 Outdoor Section With CAP**6124AL* Indoor Section																			
1450	72.0 (22.2)	57.62	29.34	3.33	55.06	28.45	3.64	52.35	27.51	4.00	49.45	26.52	4.40	46.33	25.47	4.85	42.93	24.34	5.34
	67.0 (19.4)	52.27	36.27	3.30	49.96	35.37	3.61	47.50	34.42	3.96	44.89	33.43	4.36	42.06	32.36	4.80	38.99	31.21	5.29
	63.0 (17.2)††	48.46	34.82	3.28	46.32	33.93	3.58	44.04	32.98	3.93	41.61	31.98	4.32	38.99	30.92	4.76	36.27	29.78	5.25
	62.0 (16.7)	47.76	43.03	3.27	45.72	42.07	3.58	43.61	43.61	3.92	41.60	41.60	4.32	39.46	39.46	4.77	37.10	37.10	5.26
	57.0 (13.9)	46.96	46.96	3.27	45.28	45.28	3.57	43.48	43.48	3.92	41.54	41.54	4.32	39.40	39.40	4.77	37.05	37.05	5.26
1600	72.0 (22.2)	58.29	30.53	3.40	55.66	29.63	3.72	52.87	28.68	4.07	49.88	27.67	4.48	46.67	26.60	4.92	43.18	25.45	5.41
	67.0 (19.4)	52.93	38.14	3.37	50.54	37.23	3.68	48.00	36.26	4.03	45.34	35.26	4.43	42.44	34.16	4.87	39.32	32.99	5.36
	63.0 (17.2)††	49.09	36.56	3.35	46.88	35.65	3.65	44.54	34.69	4.00	42.04	33.67	4.40	39.35	32.58	4.84	36.45	31.40	5.32
	62.0 (16.7)	48.65	48.65	3.35	46.73	46.73	3.65	44.87	44.87	4.01	42.76	42.76	4.40	40.50	40.50	4.85	38.02	38.02	5.34
	57.0 (13.9)	48.43	48.43	3.35	46.66	46.66	3.65	44.76	44.76	4.00	42.70	42.70	4.40	40.45	40.45	4.85	37.97	37.97	5.34
1800	72.0 (22.2)	58.97	32.04	3.50	56.24	31.13	3.81	53.42	30.21	4.17	50.27	29.14	4.57	46.98	28.06	5.02	43.40	26.90	5.51
	67.0 (19.4)	53.60	40.56	3.47	51.15	39.60	3.78	48.54	38.65	4.13	45.80	37.61	4.53	42.83	36.49	4.97	39.65	35.25	5.46
	63.0 (17.2)††	49.74	38.80	3.44	47.46	37.87	3.75	45.05	36.88	4.10	42.49	35.84	4.49	39.74	34.71	4.93	36.80	33.45	5.42
	62.0 (16.7)	50.16	50.16	3.45	48.27	48.27	3.76	44.97	44.97	4.11	44.05	44.05	4.51	41.66	41.66	4.96	39.03	39.03	5.45
	57.0 (13.9)	50.09	50.09	3.45	48.20	48.20	3.75	46.18	46.18	4.11	43.99	43.99	4.51	41.61	41.61	4.96	38.99	38.99	5.45
34SCA560W003 Outdoor Section With CAP**6124AL* Indoor Section																			
1600	72.0 (22.2)	69.06	34.44	4.16	65.90	33.30	4.57	62.50	32.08	5.04	58.86	30.80	5.56	54.84	29.39	6.12	50.50	27.90	6.74
	67.0 (19.4)	62.89	42.08	4.09	60.05	40.94	4.50	57.00	39.73	4.96	53.67	38.42	5.47	50.07	37.03	6.04	46.10	35.43	6.66
	63.0 (17.2)††	58.39	40.53	4.04	55.81	39.41	4.44	52.98	38.21	4.89	49.91	36.91	5.40	46.57	35.52	5.97	42.93	34.02	6.59
	62.0 (16.7)	57.44	49.55	4.03	54.94	48.42	4.43	52.23	47.17	4.88	49.30	45.79	5.40	46.40	46.40	5.97	43.30	43.30	6.60
	57.0 (13.9)	55.45	55.45	4.01	53.46	53.46	4.41	51.28	51.28	4.87	48.87	48.87	5.39	46.21	46.21	5.97	43.24	43.24	6.60
1750	72.0 (22.2)	69.90	35.60	4.24	66.64	34.44	4.65	63.13	33.21	5.11	59.33	31.89	5.63	55.25	30.49	6.20	50.81	28.99	6.82
	67.0 (19.4)	63.70	43.94	4.17	60.78	42.79	4.58	57.62	41.55	5.04	54.20	40.23	5.55	50.51	38.82	6.12	46.48	37.29	6.74
	63.0 (17.2)††	59.18	42.27	4.12	56.48	41.12	4.52	53.59	39.91	4.97	50.43	38.59	5.48	47.01	37.18	6.05	43.28	35.65	6.67
	62.0 (16.7)	58.37	52.08	4.11	55.79	50.88	4.51	53.06	49.54	4.97	50.24	50.24	5.48	47.43	47.43	6.06	44.31	44.31	6.70
	57.0 (13.9)	57.11	57.11	4.10	55.02	55.02	4.50	52.71	52.71	4.96	50.17	50.17	5.48	47.37	47.37	6.06	44.25	44.25	6.69
2000	72.0 (22.2)	70.94	37.46	4.36	67.53	36.28	4.77	63.87	35.03	5.24	59.93	33.69	5.76	55.71	32.27	6.33	51.12	30.76	6.94
	67.0 (19.4)	64.74	46.94	4.29	61.68	45.75	4.70	58.39	44.49	5.16	54.84	43.13	5.68	51.03	41.68	6.25	46.90	40.10	6.86
	63.0 (17.2)††	60.19	45.05	4.24	57.37	43.88	4.64	54.36	42.62	5.10	51.08	41.28	5.61	47.55	39.82	6.18	43.72	38.22	6.80
	62.0 (16.7)	59.73	55.90	4.24	57.20	57.20	4.64	54.72	54.72	5.11	51.97	51.97	5.63	48.96	48.96	6.21	45.62	45.62	6.84
	57.0 (13.9)	59.39	59.39	4.24	57.12	57.12	4.64	54.64	54.64	5.11	51.90	51.90	5.63	48.90	48.90	6.21	45.56	45.56	6.84

† Total and sensible capacities are net capacities. Blower motor heat has been subtracted.

‡ Sensible capacities shown are based on 80F (27C) entering air at the indoor coil. For sensible capacities at other than 80F (27C), deduct 835 Btu/h

(245 kW) per 1000 CFM (480 L/S) of indoor coil air for each degree below 80F (27C), or add 835 Btu/h (245 kW) per 1000 CFM (480 L/S) of indoor coil air per degree above 80F (27C).

** System kW is total of indoor and outdoor unit kilowatts.

EWB = Entering Wet Bulb

NOTES:

1. Detailed cooling capacities are based on indoor and outdoor unit at the same elevation per AHRI standard 210/240-2008. If additional tubing length and/or indoor unit is located above outdoor unit, a slight variation in capacity may occur.
2. When the required data falls between the published data, interpolation may be performed. Extrapolation is not an acceptable practice.

Manufacturer reserves the right to change, at any time, specifications and designs without notice and without obligations.

CONDENSER ONLY RATINGS

SST °F		CONDENSER ENTERING AIR TEMPERATURES °F (°C)						
		55.0 (12.8)	65.0 (18.3)	75.0 (23.9)	85.0 (29.4)	95.0 (35.0)	105.0 (40.6)	115.0 (46.1)
34SCA518W003								
30.0 (-1.1)	TCG	14.69	13.81	12.97	12.15	11.33	10.48	9.58
	SDT	68.94	78.28	87.71	97.17	106.62	116.03	125.38
	KW	0.69	0.79	0.90	1.02	1.16	1.31	1.49
35.0 (1.7)	TCG	16.20	15.26	14.37	13.49	12.60	11.67	10.69
	SDT	70.22	79.58	88.98	98.39	107.77	117.12	126.41
	KW	0.69	0.79	0.90	1.02	1.16	1.32	1.50
40.0 (4.4)	TCG	17.84	16.84	15.89	14.94	13.96	12.96	11.89
	SDT	71.68	80.99	90.34	99.70	109.02	118.30	127.52
	KW	0.68	0.79	0.90	1.03	1.17	1.33	1.50
45.0 (7.2)	TCG	19.62	18.56	17.53	16.50	15.45	14.35	13.19
	SDT	73.25	82.52	91.81	101.11	110.36	119.57	128.70
	KW	0.68	0.79	0.90	1.03	1.17	1.33	1.51
50.0 (10.0)	TCG	21.54	20.42	19.31	18.20	17.06	15.87	14.61
	SDT	74.95	84.17	93.40	102.63	111.81	120.93	129.97
	KW	0.68	0.78	0.90	1.03	1.17	1.34	1.52
55.0 (12.8)	TCG	23.62	22.43	21.24	20.04	18.80	17.51	16.14
	SDT	76.80	85.95	95.13	104.27	113.37	122.40	131.34
	KW	0.68	0.78	0.90	1.03	1.18	1.34	1.53
34SCA524W003								
30.0 (-1.1)	TCG	20.61	19.47	18.35	17.21	16.05	14.86	13.62
	SDT	72.29	81.59	90.89	100.22	109.55	118.81	128.04
	KW	0.97	1.08	1.21	1.36	1.53	1.73	1.96
35.0 (1.7)	TCG	22.68	21.46	20.24	19.01	17.76	16.46	15.11
	SDT	73.72	83.01	92.34	101.65	110.90	120.10	129.25
	KW	0.96	1.08	1.22	1.37	1.54	1.74	1.98
40.0 (4.4)	TCG	24.90	23.58	22.26	20.93	19.57	18.17	16.71
	SDT	75.36	84.65	93.92	103.15	112.34	121.45	130.52
	KW	0.95	1.08	1.22	1.38	1.56	1.76	1.99
45.0 (7.2)	TCG	27.25	25.83	24.41	22.97	21.50	19.98	18.40
	SDT	77.16	86.39	95.59	104.75	113.86	122.89	131.86
	KW	0.94	1.08	1.23	1.39	1.57	1.78	2.02
50.0 (10.0)	TCG	29.76	28.23	26.70	25.14	23.55	21.90	20.20
	SDT	79.06	88.23	97.36	106.44	115.46	124.40	133.26
	KW	0.93	1.08	1.23	1.40	1.59	1.80	2.04
55.0 (12.8)	TCG	32.43	30.77	29.12	27.44	25.71	23.94	22.10
	SDT	81.07	90.17	99.22	108.22	117.14	125.99	134.72
	KW	0.92	1.07	1.24	1.42	1.61	1.83	2.07
34SCA530W003								
30.0 (-1.1)	TCG	22.77	21.58	20.46	19.30	18.10	16.82	15.45
	SDT	69.63	79.02	88.52	97.96	107.37	116.73	126.02
	KW	1.16	1.32	1.48	1.67	1.87	2.10	2.37
35.0 (1.7)	TCG	25.16	23.88	22.63	21.37	20.05	18.67	17.18
	SDT	71.12	80.48	89.87	99.25	108.60	117.88	127.10
	KW	1.17	1.32	1.49	1.67	1.88	2.11	2.38
40.0 (4.4)	TCG	27.70	26.32	24.97	23.60	22.17	20.64	19.05
	SDT	72.67	81.97	91.31	100.64	109.92	119.08	128.30
	KW	1.17	1.33	1.50	1.68	1.89	2.13	2.40
45.0 (7.2)	TCG	30.49	29.00	27.51	26.01	24.46	22.80	21.03
	SDT	74.42	83.66	92.88	102.14	111.33	120.43	129.44
	KW	1.18	1.34	1.50	1.69	1.90	2.14	2.42
50.0 (10.0)	TCG	33.48	31.86	30.26	28.60	26.91	25.13	23.21
	SDT	76.27	85.44	94.62	103.73	112.86	121.89	130.80
	KW	1.19	1.35	1.52	1.70	1.92	2.16	2.44
55.0 (12.8)	TCG	36.68	34.94	33.19	31.42	29.56	27.61	25.55
	SDT	78.20	87.33	96.42	105.51	114.49	123.41	132.26
	KW	1.20	1.36	1.53	1.72	1.93	2.18	2.46

CONDENSER ONLY RATINGS

SST °F		CONDENSER ENTERING AIR TEMPERATURES °F (°C)						
		55.0 (12.8)	65.0 (18.3)	75.0 (23.9)	85.0 (29.4)	95.0 (35.0)	105.0 (40.6)	115.0 (46.1)
34SCA536W003								
30.0 (-1.1)	TCG	29.70	28.04	26.46	24.90	23.31	21.66	19.85
	SDT	69.48	78.83	88.21	97.59	106.98	116.33	125.57
	KW	1.29	1.56	1.80	2.04	2.29	2.56	2.86
35.0 (1.7)	TCG	32.70	30.95	29.24	27.54	25.79	23.98	22.04
	SDT	70.83	80.18	89.50	98.83	108.13	117.41	126.60
	KW	1.31	1.57	1.81	2.05	2.30	2.58	2.89
40.0 (4.4)	TCG	36.02	34.05	32.23	30.37	28.45	26.46	24.31
	SDT	72.49	81.58	90.89	100.15	109.37	118.55	127.68
	KW	1.33	1.58	1.82	2.07	2.32	2.60	2.92
45.0 (7.2)	TCG	39.49	37.43	35.40	33.37	31.27	29.10	26.77
	SDT	74.08	83.20	92.35	101.51	110.66	119.76	128.81
	KW	1.35	1.60	1.83	2.07	2.33	2.62	2.95
50.0 (10.0)	TCG	43.18	41.02	38.83	36.57	34.30	31.90	29.35
	SDT	75.74	84.88	93.96	102.98	112.06	121.05	129.96
	KW	1.37	1.61	1.84	2.08	2.34	2.63	2.96
55.0 (12.8)	TCG	47.19	44.80	42.39	39.96	37.49	34.85	32.09
	SDT	77.67	86.62	95.56	104.53	113.52	122.39	131.19
	KW	1.39	1.62	1.84	2.08	2.34	2.64	2.98
34SCA548W003								
30.0 (-1.1)	TCG	39.83	37.84	35.82	33.79	31.68	29.48	27.14
	SDT	73.49	82.82	92.12	101.43	110.71	119.92	129.08
	KW	2.10	2.30	2.54	2.82	3.15	3.52	3.94
35.0 (1.7)	TCG	43.87	41.67	39.50	37.28	34.99	32.60	30.09
	SDT	75.31	84.50	93.75	102.98	112.18	121.33	130.40
	KW	2.12	2.32	2.57	2.86	3.19	3.56	3.99
40.0 (4.4)	TCG	48.20	45.84	43.47	41.07	38.58	35.98	33.26
	SDT	77.20	86.34	95.50	104.66	113.77	122.81	131.81
	KW	2.14	2.35	2.60	2.89	3.22	3.61	4.03
45.0 (7.2)	TCG	52.89	50.33	47.75	45.14	42.43	39.63	36.67
	SDT	79.25	88.31	97.38	106.46	115.46	124.42	133.30
	KW	2.15	2.37	2.62	2.92	3.27	3.65	4.08
50.0 (10.0)	TCG	57.95	55.19	52.37	49.53	46.59	43.55	40.34
	SDT	81.46	90.46	99.40	108.37	117.28	126.14	134.88
	KW	2.17	2.40	2.65	2.96	3.31	3.70	4.14
55.0 (12.8)	TCG	63.41	60.39	57.34	54.25	51.05	47.75	44.28
	SDT	83.84	92.70	101.57	110.43	119.23	127.96	136.56
	KW	2.19	2.42	2.69	3.00	3.36	3.75	4.19
34SCA560W003								
30.0 (-1.1)	TCG	49.63	47.15	44.64	42.06	39.35	36.46	33.33
	SDT	78.52	87.62	96.70	105.79	114.81	123.73	132.55
	KW	2.56	2.83	3.15	3.51	3.93	4.41	4.94
35.0 (1.7)	TCG	54.66	51.97	49.26	46.41	43.48	40.35	37.03
	SDT	80.79	89.79	98.80	107.73	116.68	125.49	134.21
	KW	2.61	2.89	3.21	3.58	4.01	4.49	5.03
40.0 (4.4)	TCG	60.20	57.14	54.24	51.12	47.90	44.51	40.92
	SDT	83.19	92.10	101.04	109.88	118.66	127.36	135.94
	KW	2.67	2.94	3.27	3.65	4.09	4.58	5.12
45.0 (7.2)	TCG	65.87	62.69	59.47	56.13	52.64	48.95	45.06
	SDT	85.79	94.57	103.37	112.12	120.79	129.34	137.76
	KW	2.70	3.00	3.34	3.73	4.17	4.67	5.22
50.0 (10.0)	TCG	72.12	68.66	65.16	61.47	57.66	53.67	49.45
	SDT	88.62	97.25	105.92	114.64	123.01	131.44	139.67
	KW	2.76	3.06	3.41	4.10	4.26	4.77	5.32
55.0 (12.8)	TCG	78.77	75.01	71.13	67.14	63.02	58.65	54.10
	SDT	91.57	100.09	108.57	117.02	125.40	133.62	141.70
	KW	2.82	3.13	3.49	3.90	4.36	4.87	5.42

* AHRI listing applies only to systems shown in Combination Ratings table.

• KW - Outdoor Unit Kilowatts Only.

• SDT - Saturated Temperature Leaving Compressor (°F)

• SST - Saturated Temperature Entering Compressor (°F/°C)

• TCG - Gross Cooling Capacity (1000 Btuh)

GUIDE SPECIFICATIONS

GENERAL

SYSTEM DESCRIPTION

Outdoor-mounted, air-cooled, split-system air conditioning unit suitable for ground or rooftop installation. Unit consists of a scroll-type hermetic compressor, an air-cooled coil, propeller-type condenser fan, and a control box. Unit discharges supply air horizontally as shown on contract drawings.

Unit should be used in a refrigeration circuit to match up to a packaged fan coil or furnace.

Quality Assurance

- Unit is rated in accordance with the latest edition of AHRI Standard 210.
- Unit is certified for capacity and efficiency, and listed in the latest AHRI directory.
- Unit construction complies with latest edition of ANSI/ASHRAE and with NEC.
- Unit is constructed in accordance with UL standards and carries the UL label of approval. Unit has c-UL approval.
- Unit cabinet is capable of withstanding Federal Test Method Standard No. 141 (Method 6061) 500-hr salt spray test.
- Air-cooled condenser coils are leak tested and pressure tested
- Unit is constructed in a ISO9001 approved facility.

Delivery, Storage, and Handling

- Unit is shipped as single package only and is stored and handled per unit manufacturer's recommendations.
- Warranty (for inclusion by specifying engineer)
- U.S. and Canada only.

PRODUCTS

Equipment

- Factory assembled, single piece, air-cooled air conditioning unit. Contained within the unit enclosure is all factory wiring, piping, controls, compressor, refrigerant charge Puron (R-410A), and special features required prior to field startup.

Unit Cabinet

- Unit cabinet is constructed of galvanized steel and pre- and post-painted sheet metal.

Fans

- Condenser fan is direct-drive propeller type, discharging air horizontally
- Condenser fan motors are totally enclosed, 1-phase type with class B insulation and permanently lubricated bearings. Shafts are corrosion resistant.
- Fan blades are statically and dynamically balanced.
- Condenser fan openings are equipped with coated steel wire safety guards

AIR-COOLED, SPLIT-SYSTEM AIR CONDITIONER

34SCA5

1-1/2 TO 5 NOMINAL TONS

Compressor

- Compressor is a scroll-type, hermetically sealed.
- Compressor is mounted on rubber vibration isolators.

Condenser Coil

- Condenser coil is air cooled.
- Coil is constructed of aluminum fins mechanically bonded to copper tubes which are then cleaned, dehydrated, and sealed.

Refrigeration Components

- Refrigeration circuit components include liquid-line front seating shutoff valve with sweat connections, vapor-line front-seating shutoff valve with sweat connections, system charge of Puron (R-410A) refrigerant, and compressor oil.
- Unit is equipped with high-pressure switch.
- Filter drier for Puron (R-410A) refrigerant is provided for field installation.

Operating Characteristics

- The capacity of the unit meets or exceeds _____ Btuh at a suction temperature of _____ °F/°C. The power consumption at full load does not exceed _____ kW.
- Combination of the unit and the evaporator or fan coil unit has a total net cooling capacity of _____ Btuh or greater at conditions of _____ CFM entering air temperature at the evaporator at _____ °F/°C wet bulb and _____ F/C dry bulb, and air entering the unit at _____ F/C.
- The system has a SEER of _____ Btuh/watt or greater at DOE conditions.

Electrical Requirements

- Nominal unit electrical characteristics is _____ v, single phase, 60 hz. The unit is capable of satisfactory operation within voltage limits of _____ v to _____ v.
- Nominal unit electrical characteristics is _____ v, three phase, 60 hz. The unit is capable of satisfactory operation within voltage limits of _____ v to _____ v.
- Unit electrical power is a single point connection.
- Control circuit is 24V.

Special Features

- Refer to the section of this literature identifying accessories and descriptions for specific features and available enhancements.

