

**FJ4  
Base Series Fan Coil  
Sizes 18 - 60**



## Product Data



A10083

### AIR HANDLER TECHNOLOGY AT ITS FINEST

The FJ4 fan coil has the proven technology of Bryant fan coil units with Puron® refrigerant as well as vertical and horizontal applications. The design features contoured condensate pans with rugged drain connections, ensuring that little water is left in the unit at the end of the cooling duty cycle. The lack of standing condensate and corrosion free pans improves IAQ and product life, features homeowners appreciate.

Standard features include grooved tubing and louvered fins. Coil circuiting has also been updated to make the most of all Bryant heat pumps and air conditioners. Units come with solid state fan controls, 1-inch (25mm) thick insulation with R-value of 4.2, multi-speed motors, and fully-wettable coils. Units can accommodate factory- and/or field-installed heaters from 3 to 30 kW.

Assembled at the factory compliant with low leak requirements of less than 2% cabinet leakage rate at 0.5 inches W.C. and 1.4% cabinet leakage rate at 0.5 inches W.C. when tested in accordance with ASHRAE 193 standard.

The FJ4 fan coil design is loaded with popular features. These fan coils utilize the latest in electronic commutation motor (ECM) technology through the use of high efficiency, multi-tap ECM motors allowing reliable air delivery with increased static pressure. It comes in a pre-painted (taupe metallic) galvanized steel casing and a factory-supplied power plug for ease of installation. The unit is shipped with a Puron refrigerant TXV (sizes 18–60).

### STANDARD FEATURES

- Multi-tap ECM (electronic commutating motor) motors – all sizes
- Integrated motor controls, with 90-sec off TDR function, have replaced integrated circuit board
- Five available speed tags to meet a wide range of applications
- Large, grooved tube, louvered fin coils
- Efficient, quiet, time-tested blower housings and diffusers
- Sturdy, drainable condensate pans
- Cabinet construction features innovations designed to prevent cabinet sweating
- Tested for condensate disposal in much tougher conditions than Air Conditioning and Refrigeration Institute requirements
- Super-thick R-4.2 insulation with vapor barrier
- Pre-painted galvanized steel cabinet (taupe metallic)
- Design meets stringent regulations for cabinet air leakage of less than 2% when tested at 0.5 inches W.C., and cabinet air leakage less than 1.4% at 0.5 inches W.C. when tested in accordance with ASHRAE 193 standard.
- Installation-flexible, multipoise units
- Horizontal hanging provisions on cabinet
- No tools required to access filter
- Newly improved filter rack area filter door insulation added for improved air seal
- Factory-installed heater packages available on select models (5 through 15 kW)
- 3 through 30 kW accessory heaters - field installed
- Factory-supplied power plug
- Easy plug-in provisions for heater installation
- Entry options for high and low voltage wiring hook-up
- Leak-preventing sweat connections
- Thermostatic expansion valve, TXV, on all coils
- Designed for manufactured housing applications.

## MODEL NUMBER NOMENCLATURE

	1	2	3	4	5	6	7	8	9	10	11	12
	F	J	4	D	N	X	C	3	6	L	0	0
<b>Product</b> F = Fan Coil								<b>Heater Size</b> 00 = No Heat 05 = 5 kW 08 = 8 kW 10 = 10 kW 11 = 11 kW 15 = 15 kW				
<b>Type</b> J = Base, Puron								<b>Coil Type</b> L = Aluminum				
<b>Position</b> 4 = Multipoise												
<b>Series</b> D												
<b>Electrical</b> N = 208/230V, 1 ph, 60 Hz												
<b>Cabinet Style</b> <b>Metering Device</b> X = TXV								<b>Capacity</b> 18 = 18,000 24 = 24,000 30 = 30,000 36 = 36,000 42 = 42,000 48 = 48,000 60 = 60,000				
<b>Cabinet Width</b> A = 14"; B = 17" C = 21"; D = 24"												



Use of the AHRI Certified TM Mark indicates a manufacturer's participation in the program. For verification of certification for individual products, go to [www.ahridirectory.org](http://www.ahridirectory.org).



# DIMENSIONS

Manufacturer reserves the right to change, at any time, specifications and designs without notice and without obligations.

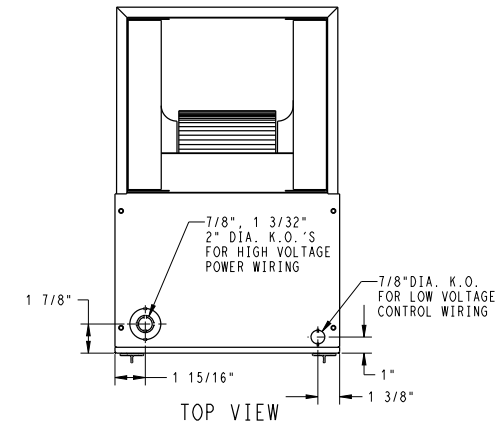

UNIT	SERIES	ELECTRICAL CHARACTERISTICS			A	B	C	D	E	F	G	H	J	COIL CONFIGURATION		SHIPPING WT (LBS)
		SLOPE	"A"													
FJ4DNXA18	A	X	*		42 11/16"	14 5/8"	12 7/16"	12 5/16"	10 7/16"	18 1/8"	18 5/8"	-	12"	X	-	-
FJ4DNXB24	A	X	*		49 5/8"	17 5/8"	15 3/4"	15 5/8"	15 3/8"	23 1/8"	23 5/8"	-	17"	X	-	-
FJ4DNXB30	A	X	*		49 5/8"	17 5/8"	15 3/4"	15 5/8"	15 7/8"	23 1/8"	23 1/2"	-	-	-	X	-
FJ4DNXB36	A	X	*		49 5/8"	17 5/8"	15 3/4"	15 5/8"	15 7/8"	23 1/8"	23 1/2"	-	-	-	X	-
FJ4DNXC42	A	X	*		49 5/8"	21 1/8"	19 1/4"	19 1/8"	15 11/16"	23 7/16"	23 1/8"	-	-	-	X	-
FJ4DNXC48	A	X	*		53 7/16"	21 1/8"	19 1/4"	19 1/8"	19 1/2"	27 1/4"	26 15/16"	-	-	-	X	-
FJ4DNXD60	A	X	*		59 3/16"	24 11/16"	22 3/4"	22 11/16"	25 1/4"	32 15/16"	32 5/8"	-	-	-	X	-

208/230-1-60  
208/230-3-60

X=YES  
O=NO  
\*=YES, DUE TO AVAILABLE FIELD INSTALLED HEATERS.

- NOTE:
- SERIES DESIGNATION IS THE 14TH POSITION OF UNIT PRODUCT NUMBER
  - ALL DIMENSIONS ARE IN "INCHES" UNLESS NOTED.

NOTE: ALLOW 21" FROM FRONT FOR SERVICE

### UNIT CONNECTION SIZES

SUCTION: 018 THRU 024 - 5/8" I.D. SWEAT  
030 & 036 - 3/4" I.D. SWEAT  
042 THRU 060 - 7/8" I.D. SWEAT  
LIQUID: 3/8" I.D. SWEAT  
CONDENSATE: 3/4" FPT

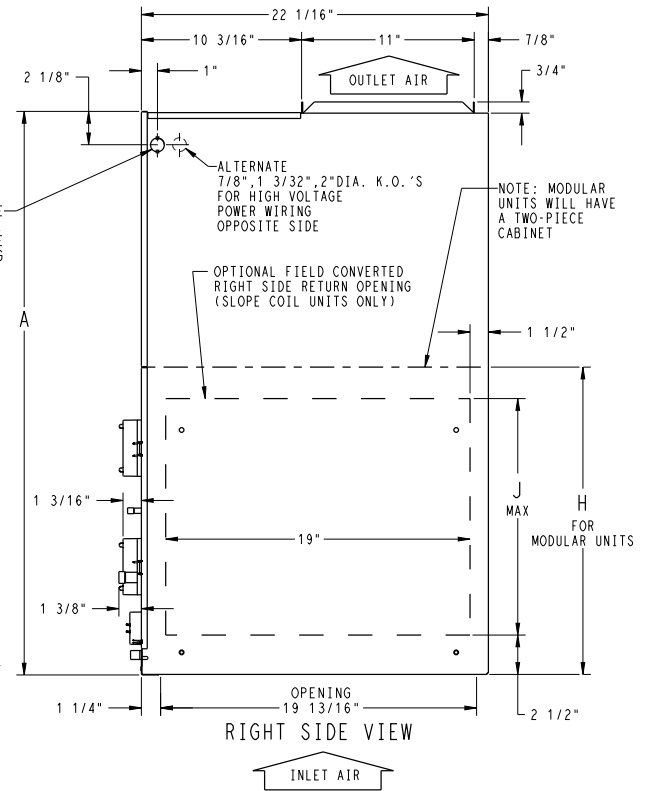
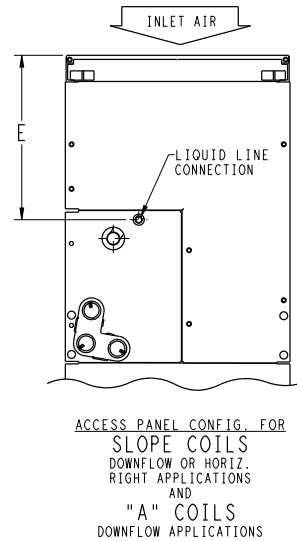
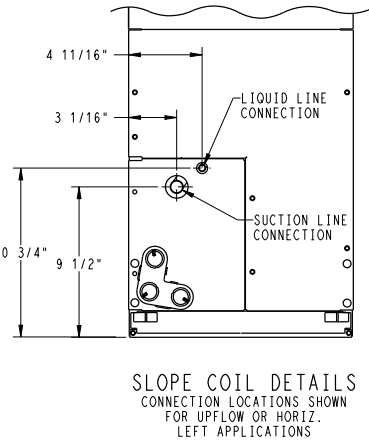
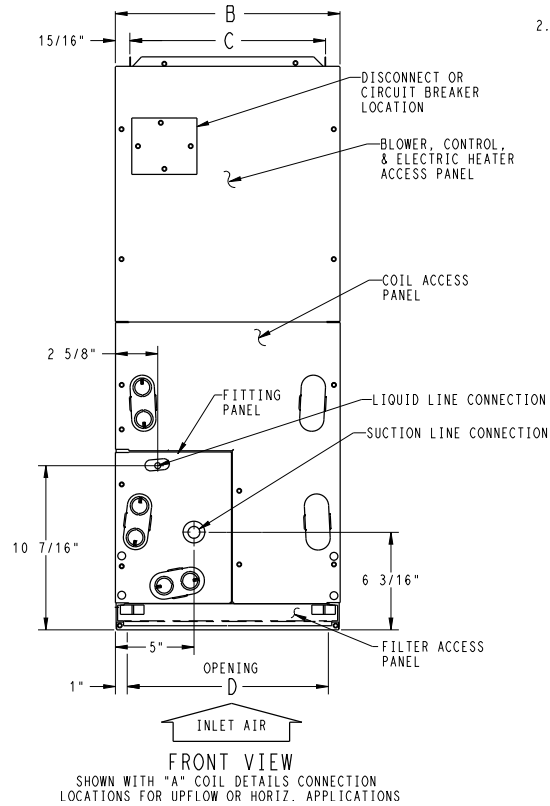
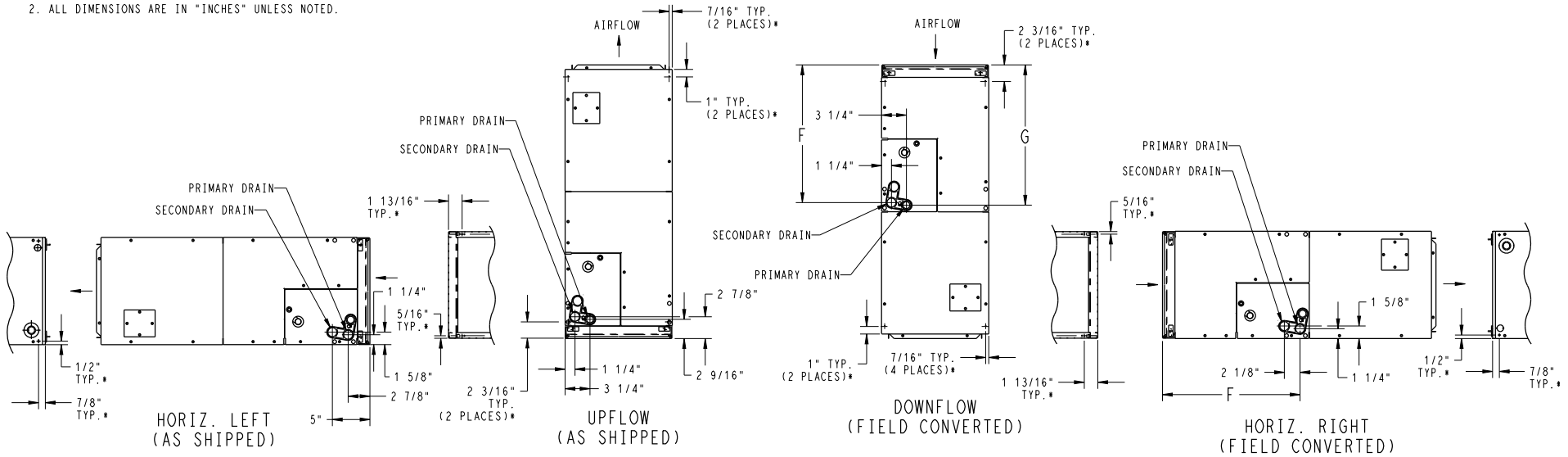

Fig. 1 – FJ4 - English (sheet 1)

**DIMENSIONS (cont.)**

- NOTES:  
 1. CONDENSATE PAN DRAIN CAPS NOT SHOWN FOR CLARITY.  
 2. ALL DIMENSIONS ARE IN "INCHES" UNLESS NOTED.

SLOPE COIL



- \* HORIZONTAL MOUNT LOCATIONS - DIMPLES PROVIDED IN TOP PANEL, AND BACK OF CABINET. IN CABINET BOTTOM, HOLES PROVIDED .136" DIA. HORIZONTAL HANGING HARDWARE TO BE FIELD SUPPLIED.

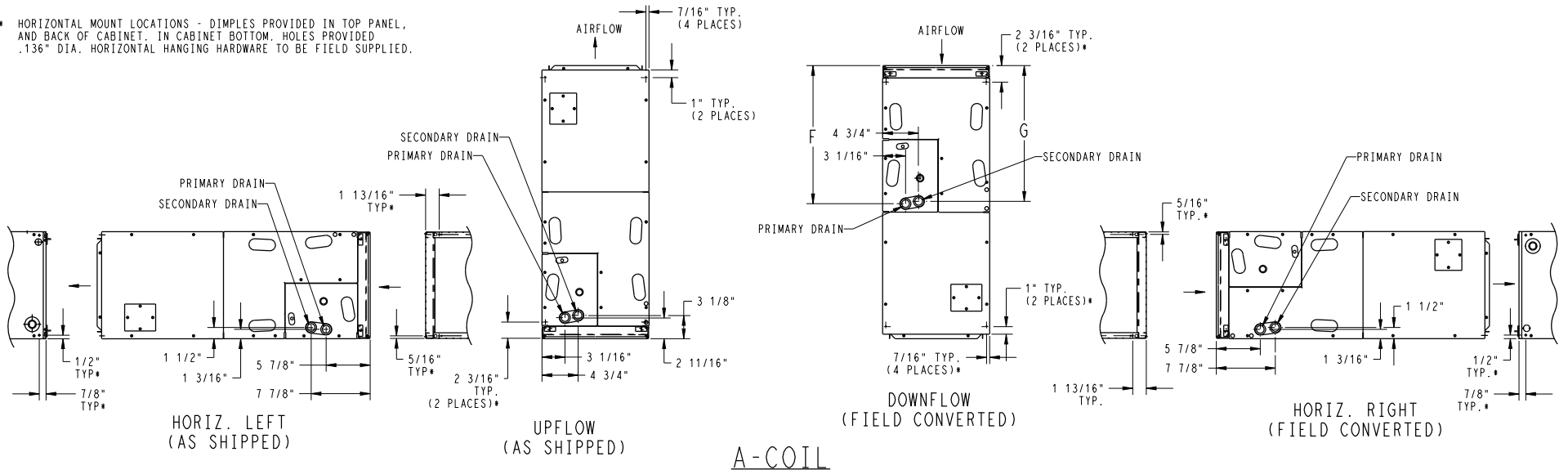

A-COIL

**Fig. 2 – FJ4- English (sheet 2)**

A221148

Manufacturer reserves the right to change, at any time, specifications and designs without notice and without obligations.

**DIMENSIONS (cont.)**

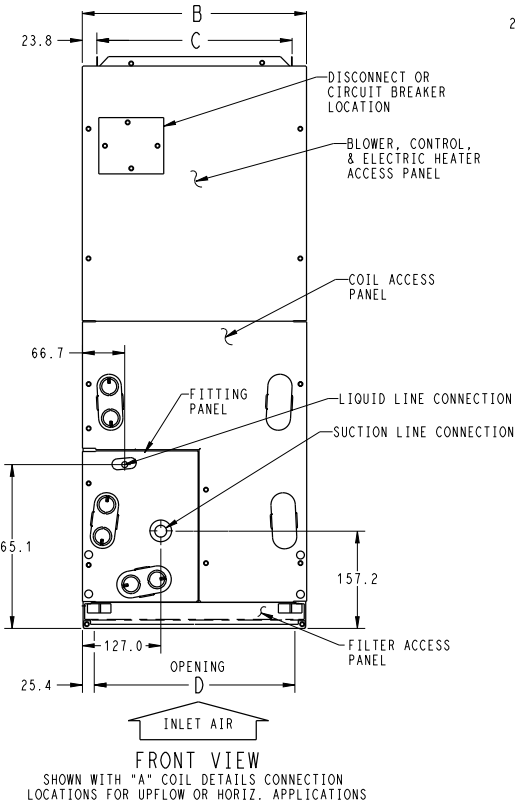
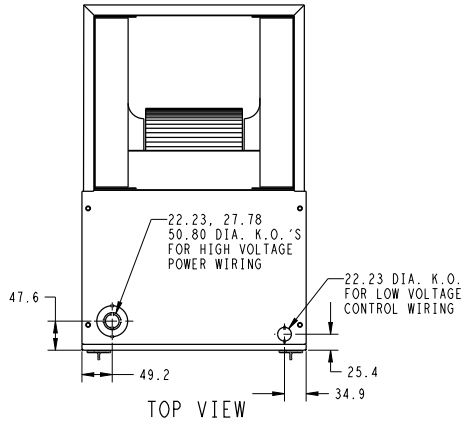

UNIT	SERIES	ELECTRICAL CHARACTERISTICS			A	B	C	D	E	F	G	H	J	COIL CONFIGURATION		SHIPPING WT (Kgs)
		SLOPE	"A"													
FJ4DNXA18	A	X	*		1084.3	363.6	315.9	312.8	265.1	460.4	473.1	-	304.8	X	-	-
FJ4DNXB24	A	X	*		1260.5	447.7	400.0	396.9	390.5	587.4	600.1	-	431.8	X	-	-
FJ4DNXB30	A	X	*		1260.5	447.7	400.0	396.9	403.2	587.4	596.9	-	-	-	X	-
FJ4DNXB36	A	X	*		1260.5	447.7	400.0	396.9	403.2	587.4	596.9	-	-	-	X	-
FJ4DNXC42	A	X	*		1260.5	536.6	489.0	485.8	398.5	595.3	587.4	-	-	-	X	-
FJ4DNXC48	A	X	*		1357.3	536.6	489.0	485.8	495.3	692.2	684.2	-	-	-	X	-
FJ4DNXD60	A	X	*		1503.4	627.1	577.8	576.3	641.4	836.6	828.7	-	-	-	X	-

208/230-1-60	
208/230-3-60	

X=YES  
O=NO  
\*YES, DUE TO AVAILABLE FIELD INSTALLED HEATERS.

- NOTE:
- SERIES DESIGNATION IS THE 14TH POSITION OF UNIT PRODUCT NUMBER
  - ALL DIMENSIONS ARE IN "MM" UNLESS NOTED.

NOTE: ALLOW 533.4 FROM FRONT FOR SERVICE

**UNIT CONNECTION SIZES**

SUCTION: 018 THRU 024 - 15.88 I.D. SWEAT  
030 & 036 - 19.05 I.D. SWEAT  
042 THRU 060 - 22.23 I.D. SWEAT  
LIQUID: 9.53 I.D. SWEAT  
CONDENSATE: 19.0 FPT

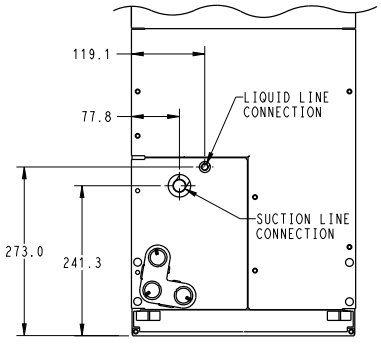

SLOPE COIL DETAILS  
CONNECTION LOCATIONS SHOWN FOR UPFLOW OR HORIZ. LEFT APPLICATIONS

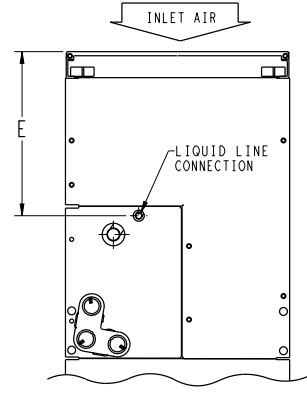

ACCESS PANEL CONFIG FOR SLOPE COILS  
DOWNFLOW OR HORIZ. RIGHT APPLICATIONS AND "A" COILS  
DOWNFLOW APPLICATIONS

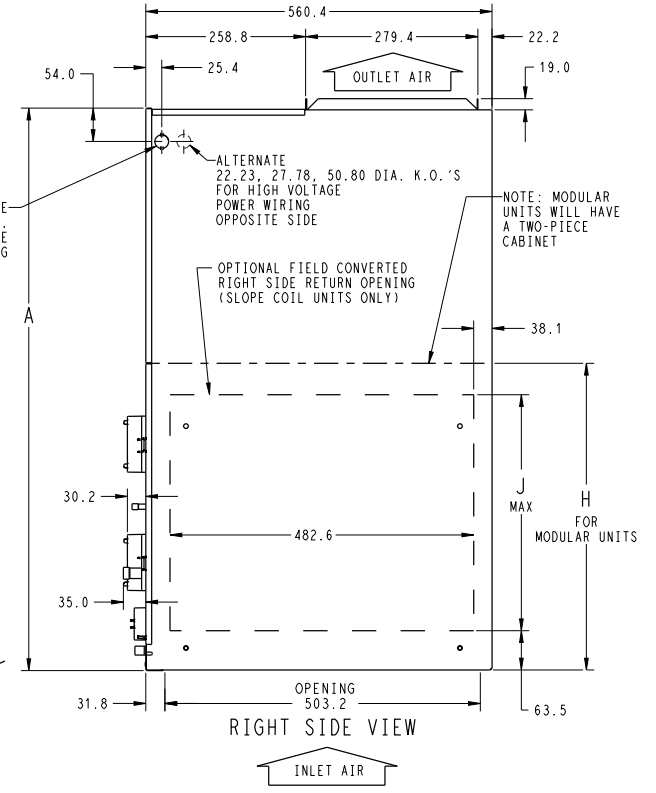

RIGHT SIDE VIEW

NOTE: MODULAR UNITS WILL HAVE A TWO-PIECE CABINET

Manufacturer reserves the right to change, at any time, specifications and designs without notice and without obligations.

**Fig. 3 – FJ4 - Metric (sheet 1)**

**DIMENSIONS (cont.)**

- NOTES:  
 1. CONDENSATE PAN DRAIN CAPS NOT SHOWN FOR CLARITY.  
 2. ALL DIMENSIONS ARE IN "MM" UNLESS NOTED.

SLOPE COIL

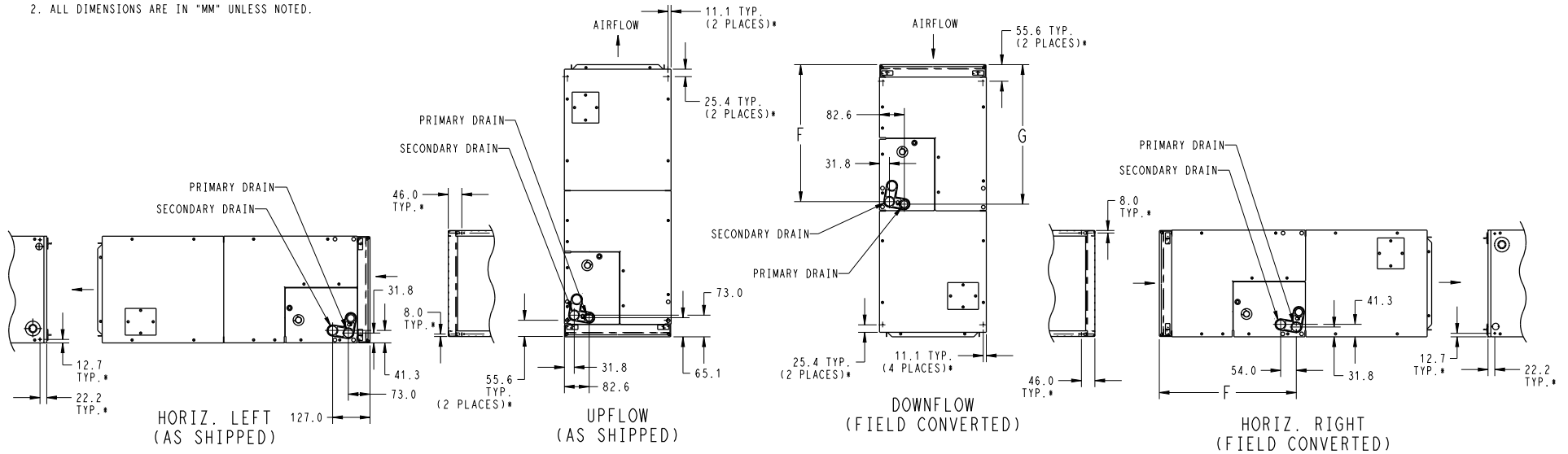

\* HORIZONTAL MOUNT LOCATIONS - DIMPLES PROVIDED IN TOP PANEL, AND BACK OF CABINET. IN CABINET BOTTOM, HOLES PROVIDED 3.45 DIA. HORIZONTAL HANGING HARDWARE TO BE FIELD SUPPLIED.

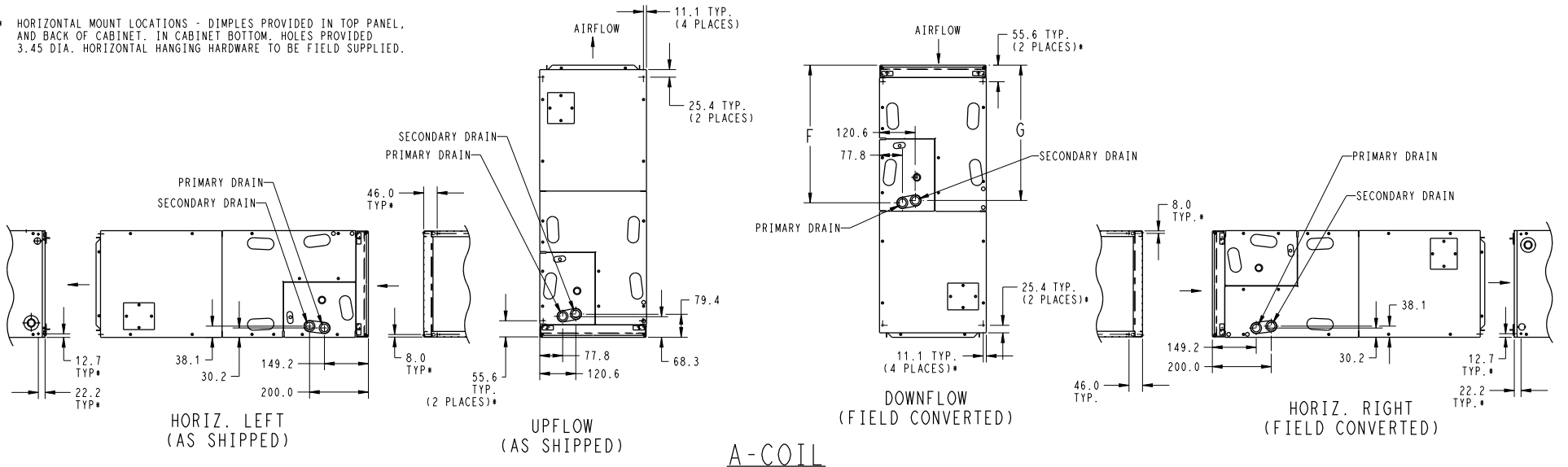

A-COIL

**Fig. 4 – FJ4 - Metric (sheet 2)**

Manufacturer reserves the right to change, at any time, specifications and designs without notice and without obligations.

**Table 1 – PHYSICAL DATA**

UNIT SIZE	NOMINAL COOLING CAPACITY (Btuh)	DIMENSIONS – IN (mm)			SHIPPING WEIGHT LB (KG)
		Height	Width	Depth	
18	18,000	42-11/16 in. (1084mm)	14-5/16 in. (364mm)	22-1/16 in. (560mm)	120 (54.4)
24	24,000	49-5/8 in. (1260mm)	17-5/8 in. (448mm)	22-1/16 in. (560mm)	131 (59.4)
30	30,000	49-5/8 in. (1260mm)	17-5/8 in. (448mm)	22-1/16 in. (560mm)	148 (67.1)
36	36,000	49-5/8 in. (1260mm)	17-5/8 in. (448mm)	22-1/16 in. (560mm)	148 (67.1)
42	42,000	49-5/8 in. (1260mm)	21-1/8 in. (537mm)	22-1/16 in. (560mm)	166 (75.3)
48	48,000	53-7/16 in. (1357mm)	21-1/8 in. (537mm)	22-1/16 in. (560mm)	182 (82.5)
60	60,000	59-3/16 in. (1503mm)	24-11/16 in. (627mm)	22-1/16 in. (560mm)	210 (95.2)

**Table 2 – SPECIFICATIONS**

SIZE	18	24	30	36	42	48	60
<b>EVAPORATOR COIL</b>							
Face Area (sq. ft)	2.23	2.97	3.96	4.45	5.93	7.42	
Configuration	Slope			A			
Metering Device	TXV						
FILTER SIZE	12-in (304.8 mm) x 20-in (508 mm)	14-in (355.6 mm) x 20-in (508 mm)	16-in (406.4 mm) X 20-in (508 mm)		20-in (508 mm) x 20-in (508 mm)	22-in (558.8 mm) x 22-in (558.8 mm)	
<b>BLOWER ASSEMBLY</b>							
Motor Type (ECM)	Multi-tap ECM						
Motor HP	1/3	1/3	1/2	1/2	1/2	3/4	3/4
CFM	600	800	1000	1200	1400	1600	2000

## PERFORMANCE DATA

**Table 3 – Airflow Performance (CFM) Wet**

Ton (Size)	Blower Speed	External Static (in. wc)									
		0.1	0.2	0.3	0.4	0.5	0.6	0.7	0.8	0.9	1.0
1-1/2 (18)	Tap 5	754	737	717	694	668	641	605	572	528	481
	Tap 4	695	678	655	628	600	573	551	520	479	421
	Tap 3	695	678	655	628	600	573	551	520	479	421
	Tap 2	643	620	591	557	534	506	477	439	408	378
	Tap 1	487	448	428	394	358	325	281	NA	NA	NA
2 (24)	Tap 5	1021	1003	964	925	876	838	797	761	726	689
	Tap 4	936	907	873	805	779	732	696	661	626	591
	Tap 3	936	907	873	805	779	732	696	661	626	591
	Tap 2	846	831	792	739	702	651	609	548	536	491
	Tap 1	746	697	629	567	521	477	446	389	364	326
2-1/2 (30)	Tap 5	1247	1215	1188	1154	1122	1083	1053	1017	971	915
	Tap 4	1133	1114	1082	1044	1009	968	924	873	835	785
	Tap 3	1133	1114	1082	1044	1009	968	924	873	835	785
	Tap 2	1040	997	961	929	883	828	782	725	708	667
	Tap 1	896	862	805	740	689	648	597	NA	NA	NA
3 (36)	Tap 5	1433	1404	1363	1328	1282	1251	1201	1145	1095	1021
	Tap 4	1304	1277	1256	1230	1207	1168	1122	1080	1073	983
	Tap 3	1304	1277	1256	1230	1207	1168	1122	1080	1073	983
	Tap 2	1183	1148	1124	1094	1051	1005	955	901	846	783
	Tap 1	1020	995	958	921	881	840	791	735	693	649
3-1/2 (42)	Tap 5	1571	1551	1508	1473	1439	1407	1372	1317	1253	1189
	Tap 4	1517	1493	1458	1425	1392	1358	1328	1295	1253	1193
	Tap 3	1517	1493	1458	1425	1392	1358	1328	1295	1253	1193
	Tap 2	1369	1339	1299	1263	1226	1188	1155	1112	1068	1012
	Tap 1	1260	1231	1172	1143	1077	1041	995	949	896	867
4 (48)	Tap 5	1896	1853	1821	1795	1760	1737	1702	1670	1665	1619
	Tap 4	1711	1673	1643	1607	1570	1549	1509	1490	1446	1411
	Tap 3	1711	1673	1643	1607	1570	1549	1509	1490	1446	1411
	Tap 2	1547	1504	1466	1416	1388	1369	1324	1290	1239	1200
	Tap 1	1397	1347	1312	1269	1232	1172	1135	1086	1038	989
5 (60)	Tap 5	2109	2067	2043	1996	1967	1928	1899	1848	1812	1766
	Tap 4	2109	2067	2043	1996	1967	1928	1899	1848	1812	1766
	Tap 3	2109	2067	2043	1996	1967	1928	1899	1848	1812	1766
	Tap 2	1901	1868	1825	1785	1737	1710	1662	1620	1584	1521
	Tap 1	1583	1557	1499	1451	1392	1358	1313	1259	1194	1138

**NOTES:**

- Airflow based upon dry coil at 230V with factory-approved filter and electric heater (2 element heater sizes 018 through 036, 3 element heater sizes 042 through 060).
- To avoid potential for condensate blowing out of drain pan prior to making drain trap:  
Return static pressure must be less than 0.40 in. wc. Horizontal applications of 042 - 060 sizes must have supply static greater than 0.20 in. wc.  
Airflow above 400 cfm/ton on 048-060 size could result in condensate blowing off coil or splashing out of drain pan.
- At higher pextstats (above 0.6 in/wc), water blowoff is more likely to occur depending on the user's setup.



**PERFORMANCE DATA (cont.)****Table 4 – Airflow Performance (CFM) Dry**

Ton (Size)	Blower Speed	External Static (in. wc)									
		0.1	0.2	0.3	0.4	0.5	0.6	0.7	0.8	0.9	1.0
<b>1-1/2 (18)</b>	Tap 5	762	741	721	698	672	656	635	577	547	509
	Tap 4	695	679	655	628	600	580	559	534	505	452
	Tap 3	695	679	655	628	600	580	559	534	505	452
	Tap 2	634	615	585	547	522	506	475	444	407	371
	Tap 1	498	470	434	390	356	300	272	NA	NA	NA
<b>2 (24)</b>	Tap 5	1046	1013	978	958	925	877	830	752	722	687
	Tap 4	992	950	916	869	812	763	705	660	611	585
	Tap 3	992	950	916	869	812	763	705	660	611	585
	Tap 2	900	862	814	769	709	644	594	548	507	451
	Tap 1	762	723	651	599	531	471	428	385	345	319
<b>2-1/2 (30)</b>	Tap 5	1277	1244	1226	1193	1169	1122	1094	1058	1014	969
	Tap 4	1179	1142	1114	1070	1039	998	937	915	867	825
	Tap 3	1179	1142	1114	1070	1039	998	937	915	867	825
	Tap 2	1066	1030	997	960	916	863	795	746	703	674
	Tap 1	923	878	832	784	723	658	616	563	NA	NA
<b>3 (36)</b>	Tap 5	1489	1463	1428	1388	1345	1305	1262	1213	1160	1093
	Tap 4	1357	1337	1310	1283	1249	1212	1165	1114	1064	1014
	Tap 3	1357	1337	1310	1283	1249	1212	1165	1114	1064	1014
	Tap 2	1211	1190	1162	1132	1100	1066	1016	959	905	838
	Tap 1	1059	1038	1004	967	925	887	843	791	747	681
<b>3-1/2 (42)</b>	Tap 5	1647	1620	1583	1548	1505	1464	1424	1379	1319	1250
	Tap 4	1569	1539	1506	1476	1442	1404	1370	1336	1299	1219
	Tap 3	1569	1539	1506	1476	1442	1404	1370	1336	1299	1219
	Tap 2	1393	1355	1329	1288	1248	1223	1180	1138	1091	1037
	Tap 1	1265	1234	1195	1154	1111	1062	1022	964	914	865
<b>4 (48)</b>	Tap 5	1956	1917	1887	1855	1831	1798	1763	1743	1707	1683
	Tap 4	1773	1743	1704	1667	1634	1612	1571	1536	1500	1464
	Tap 3	1773	1743	1704	1667	1634	1612	1571	1536	1500	1464
	Tap 2	1566	1524	1483	1451	1414	1376	1340	1303	1266	1217
	Tap 1	1413	1373	1328	1283	1246	1204	1168	1120	1075	1012
<b>5 (60)</b>	Tap 5	2148	2123	2084	2048	2002	1974	1939	1891	1893	1812
	Tap 4	2148	2123	2084	2048	2002	1974	1939	1891	1893	1812
	Tap 3	2148	2123	2084	2048	2002	1974	1939	1891	1893	1812
	Tap 2	1955	1913	1868	1833	1796	1757	1711	1654	1632	1570
	Tap 1	1646	1590	1527	1496	1442	1373	1315	1294	1221	1164

**NOTES:**

- Airflow based upon dry coil at 230V with factory-approved filter and electric heater (2 element heater sizes 018 through 036, 3 element heater sizes 042 through 060).
- To avoid potential for condensate blowing out of drain pan prior to making drain trap:  
Return static pressure must be less than 0.40 in. wc. Horizontal applications of 042 - 060 sizes must have supply static greater than 0.20 in. wc.  
Airflow above 400 cfm/ton on 048-060 size could result in condensate blowing off coil or splashing out of drain pan.
- At higher pextstats (above 0.6 in/wc), water blowoff is more likely to occur depending on the user's setup.

Table 5 – Gross Cooling Capacities

Unit Size	INDOOR COIL AIR		SATURATED TEMPERATURE LEAVING EVAPORATOR (°F / °C)														
			35/2			40/4			45/7			50/10			55/13		
	CFM	EWB	TC	SHC	BF	TC	SHC	BF	TC	SHC	BF	TC	SHC	BF	TC	SHC	BF
18	525	72/22	42.80	20.80	0.00	38.40	18.70	0.00	33.50	16.50	0.01	27.90	14.10	0.02	21.70	11.70	0.02
		67/19	34.90	21.40	0.03	30.40	19.20	0.03	25.30	16.80	0.03	19.80	14.50	0.03	13.90	12.10	0.04
		62/17	27.70	21.90	0.03	23.20	19.60	0.03	18.50	17.30	0.04	14.90	14.90	0.13	12.20	12.20	0.28
	600	72/22	46.90	22.80	0.00	42.10	20.50	0.00	36.70	18.10	0.02	30.60	15.60	0.03	23.80	13.00	0.03
		67/19	38.30	23.70	0.04	33.40	21.20	0.04	27.80	18.70	0.04	21.60	16.10	0.04	15.20	13.40	0.05
		62/17	30.40	24.30	0.04	25.40	21.80	0.04	20.30	19.30	0.06	16.50	16.50	0.15	13.60	13.60	0.30
	675	72/22	50.60	24.60	0.00	45.40	22.20	0.02	39.60	19.70	0.03	33.00	17.00	0.04	25.60	14.10	0.04
		67/19	41.40	25.70	0.05	36.10	23.10	0.05	30.10	20.40	0.05	23.40	17.60	0.05	16.50	14.80	0.06
		62/17	32.90	26.60	0.05	27.50	23.90	0.05	22.10	21.10	0.07	18.10	18.10	0.17	14.90	14.90	0.32
24	700	72/22	54.40	26.40	0.00	49.20	24.00	0.00	43.30	21.40	0.01	36.40	18.50	0.02	28.60	15.50	0.03
		67/19	44.80	27.70	0.03	39.30	25.00	0.03	33.00	22.10	0.03	26.00	19.10	0.03	18.50	16.10	0.04
		62/17	35.80	28.60	0.03	30.20	25.80	0.03	24.30	22.90	0.04	19.70	19.70	0.13	16.30	16.30	0.28
	800	72/22	59.10	28.70	0.00	53.50	26.20	0.01	47.00	23.40	0.02	39.70	20.30	0.03	31.20	17.90	0.04
		67/19	48.70	30.40	0.04	42.90	27.60	0.04	36.10	24.50	0.04	28.30	21.20	0.04	20.20	17.90	0.05
		62/17	39.10	31.60	0.04	33.00	28.60	0.05	26.60	25.40	0.06	21.90	21.90	0.16	18.10	18.10	0.30
	900	72/22	63.20	30.80	0.00	57.20	28.20	0.02	50.40	25.20	0.04	42.60	22.00	0.04	33.50	18.60	0.05
		67/19	52.30	32.80	0.05	46.10	29.90	0.05	38.90	26.70	0.05	30.50	23.20	0.05	21.80	19.60	0.06
		62/17	42.10	34.50	0.05	35.60	31.30	0.06	28.80	27.90	0.07	24.00	24.00	0.18	19.80	19.80	0.32
30	875	72/22	71.60	34.70	0.00	64.40	31.30	0.00	56.30	27.70	0.00	47.20	23.80	0.02	36.80	19.70	0.02
		67/19	58.70	36.00	0.02	51.30	32.30	0.03	42.90	28.40	0.03	33.60	24.40	0.03	23.70	20.30	0.04
		62/17	46.70	36.80	0.03	39.20	33.00	0.03	31.20	29.10	0.04	25.00	25.00	0.12	20.60	20.60	0.27
	1000	72/22	78.30	38.00	0.00	70.50	34.40	0.00	61.60	30.50	0.02	51.70	26.30	0.03	40.30	21.90	0.03
		67/19	64.30	39.70	0.03	56.30	35.80	0.03	47.10	31.50	0.04	36.80	27.10	0.04	26.00	22.70	0.05
		62/17	51.40	40.90	0.04	43.10	36.70	0.04	34.40	32.40	0.05	27.90	27.90	0.14	23.00	23.00	0.29
	1125	72/22	84.30	41.00	0.00	75.90	37.20	0.00	66.80	33.20	0.02	55.80	28.60	0.04	43.60	23.80	0.04
		67/19	69.40	43.10	0.04	60.80	38.90	0.04	51.00	34.50	0.05	39.80	29.70	0.05	28.10	24.90	0.06
		62/17	55.60	44.80	0.05	46.70	40.30	0.05	37.30	35.60	0.06	30.60	30.60	0.16	25.20	25.20	0.31
36	1050	72/22	64.89	33.39	0.00	58.38	30.18	0.00	51.08	26.68	0.02	42.84	22.99	0.03	33.40	19.04	0.03
		67/19	53.14	34.96	0.04	46.48	31.47	0.04	38.88	27.72	0.04	30.22	23.74	0.04	21.13	19.74	0.05
		62/17	42.35	36.18	0.04	35.45	32.44	0.04	28.12	28.54	0.05	22.73	22.73	0.15	18.64	18.64	0.29
	1200	72/22	70.55	36.42	0.00	63.54	32.99	0.02	55.62	29.26	0.03	46.67	25.30	0.04	36.48	21.08	0.05
		67/19	57.90	38.43	0.05	50.70	34.71	0.05	42.55	30.74	0.05	33.13	26.44	0.05	23.14	22.04	0.06
		62/17	46.31	40.09	0.05	38.86	36.09	0.05	31.02	31.87	0.07	25.31	25.31	0.17	20.78	20.78	0.31
	1350	72/22	75.52	39.17	0.00	68.14	35.55	0.03	59.70	31.64	0.04	50.12	27.45	0.05	39.26	23.00	0.06
		67/19	62.18	41.63	0.06	54.49	37.72	0.06	45.77	33.52	0.06	35.75	28.98	0.06	25.00	24.22	0.08
		62/17	49.84	43.73	0.06	42.00	39.53	0.07	33.71	35.01	0.09	27.74	27.74	0.20	22.79	22.79	0.33

**Table 5 – Gross Cooling Capacities**

Unit Size	INDOOR COIL AIR		SATURATED TEMPERATURE LEAVING EVAPORATOR (°F / °C)														
			35/2			40/4			45/7			50/10			55/13		
	CFM	EWB	TC	SHC	BF	TC	SHC	BF	TC	SHC	BF	TC	SHC	BF	TC	SHC	BF
42	1225	72/22	79.15	40.41	0.00	70.85	36.31	0.00	61.59	31.90	0.02	51.15	27.24	0.03	39.41	22.38	0.04
		67/19	64.55	42.04	0.04	56.05	37.58	0.04	46.51	32.90	0.04	35.85	28.04	0.04	24.90	23.25	0.05
		62/17	51.09	43.18	0.04	42.46	38.53	0.05	33.59	33.84	0.06	27.05	27.05	0.15	22.11	22.11	0.30
	1400	72/22	86.34	44.20	0.00	77.30	39.79	0.01	67.22	35.05	0.03	55.91	30.07	0.04	43.10	24.80	0.05
		67/19	70.55	46.30	0.05	61.37	41.55	0.05	50.95	36.50	0.05	39.20	31.18	0.06	27.27	25.94	0.07
		62/17	56.04	47.92	0.06	46.63	42.89	0.06	36.98	37.71	0.08	30.12	30.12	0.18	24.63	24.62	0.32
	1575	72/22	92.81	47.68	0.00	83.15	42.98	0.03	72.31	37.96	0.05	60.17	32.67	0.06	46.45	27.07	0.06
		67/19	76.00	50.25	0.06	66.13	45.22	0.06	55.01	39.88	0.07	42.37	34.20	0.07	29.47	28.50	0.08
		62/17	60.57	52.40	0.07	50.47	47.01	0.07	40.22	41.43	0.09	33.01	33.01	0.20	26.99	26.99	0.34
48	1400	72/22	83.95	44.30	0.00	75.71	40.05	0.00	66.36	35.45	0.01	55.84	30.58	0.02	43.82	25.38	0.03
		67/19	68.80	46.22	0.03	60.32	41.61	0.03	50.67	36.70	0.03	39.64	31.45	0.03	27.80	26.12	0.04
		62/17	54.96	47.71	0.03	46.12	42.77	0.03	36.69	37.67	0.04	29.32	29.32	0.13	24.10	24.10	0.28
	1600	72/22	91.53	48.40	0.00	82.59	43.90	0.00	72.47	38.97	0.02	61.02	33.73	0.03	48.01	28.16	0.04
		67/19	75.19	50.91	0.04	65.98	45.99	0.04	55.57	40.75	0.04	43.57	35.09	0.04	30.49	29.21	0.05
		62/17	60.21	52.94	0.04	50.73	47.68	0.04	40.48	42.10	0.06	32.72	32.72	0.15	26.92	26.92	0.30
	1800	72/22	98.31	52.15	0.00	88.79	47.39	0.02	77.99	42.21	0.03	65.70	36.65	0.04	51.81	30.76	0.05
		67/19	80.94	55.25	0.05	71.10	50.06	0.05	59.93	44.50	0.05	47.14	38.52	0.05	32.96	32.14	0.06
		62/17	64.96	57.83	0.05	54.92	52.30	0.05	44.06	46.35	0.07	35.97	35.97	0.17	29.59	29.59	0.31
60	1600	72/22	118.17	60.42	0.00	106.56	54.57	0.00	93.41	48.24	0.02	78.64	41.59	0.02	62.13	34.63	0.03
		67/19	96.74	62.87	0.03	84.83	56.56	0.03	71.43	49.91	0.03	56.41	42.93	0.03	39.37	35.48	0.04
		62/17	77.24	64.78	0.03	65.10	58.16	0.03	51.83	51.23	0.04	41.00	41.00	0.12	33.67	33.67	0.27
	1750	72/22	129.14	66.15	0.00	116.46	59.92	0.00	102.18	53.13	0.02	86.08	45.94	0.03	68.00	38.39	0.03
		67/19	105.94	69.36	0.04	92.95	62.59	0.04	78.33	55.41	0.04	61.93	47.86	0.04	43.49	39.82	0.05
		62/17	84.76	71.94	0.04	71.53	64.80	0.04	57.37	57.38	0.05	45.94	45.94	0.14	37.65	37.65	0.29
	2000	72/22	139.03	71.41	0.00	125.46	64.82	0.01	110.15	57.64	0.03	92.83	49.99	0.04	73.33	41.92	0.04
		67/19	114.27	75.38	0.05	100.34	68.21	0.05	84.61	60.58	0.05	66.92	52.51	0.05	47.25	43.94	0.06
		62/17	91.59	78.67	0.05	77.41	71.08	0.05	62.32	63.11	0.07	50.60	50.60	0.16	41.54	41.54	0.31

CFM - Cubic Ft per Minute      EWB - Entering Wet Bulb °F (°C)      LWB - Leaving Wet Bulb °F (°C)      TC - Gross Cooling Capacity 1000 Btuh  
 SHC - Gross Sensible Capacity 1000 Btuh      BF - Bypass Factor      MBH - 1000 Btuh

**NOTES:**

- Contact manufacturer for cooling capacities at conditions other than shown in table.
- Formulas:  
 Leaving db = entering db -  $\frac{\text{sensible heat cap.}}{1.09 \times \text{CFM}}$   
 Leaving wb = wb corresponding to enthalpy of air leaving coil ( $h_{lwb}$ )  
 $h_{lwb} = h_{ewb} - \frac{\text{total capacity (Btuh)}}{4.5 \times \text{CFM}}$   
 where  $h_{ewb}$  = enthalpy of air entering coil. Direct interpolation is permissible. Do not extrapolate.
- SHC is based on 80°F (27°C) db temperature of air entering coil. Below 80°F (27°C) db, subtract (Correction Factor x CFM) from SHC. Above 80°F (27°C) db, add (Correction Factor x CFM) to SHC.
- Bypass Factor = 0 indicates no psychometric solution. Use bypass factor of next lower EWB for approximation.

**SHC CORRECTION FACTOR**

BYPASS FACTOR	ENTERING AIR DRY-BULB TEMPERATURE (°F)					
	79	78	77	76	75	Under 75
	81	82	83	84	85	Over 85
BYPASS FACTOR	ENTERING AIR DRY-BULB TEMPERATURE (°C)					
	26	25	25	24	24	Under 75
	27	28	28	29	29	Over 85
Correction Factor						
0.10	.098	1.96	2.94	3.92	4.91	Use formula shown below
0.20	0.87	1.74	2.62	3.49	4.36	
0.30	0.76	1.53	2.29	3.05	3.82	

Interpolation is permissible.  
 Correction Factor =  $1.09 \times (1 - \text{BF}) \times (\text{db} - 80)$

**PERFORMANCE DATA (cont.)****Table 6 – Electric Heater Static Pressure Drop (in wc)**

SIZES 18 - 36			SIZES 42 - 60		
HEATER ELEMENTS	kW	EXTERNAL STATIC PRESSURE CORRECTION	HEATER ELEMENTS	kW	EXTERNAL STATIC PRESSURE CORRECTION
0	0	+02	0	0	+04
1	3, 5	+01	1	3, 5	+03
2	8, 10	0	2	8, 10	+02
3	9, 15	-.02	3	9, 15	0
4	20	-.04	4	20	-.02
			6	18, 24, 30	-.10

The airflow performance data was developed using fan coils with 10-kW electric heaters (2 elements) in the 018 through 036 size units and 15-kW heaters (3 elements) in the 042 through 061 size units. For fan coils with heaters of a different number of elements, the external available static at a given CFM from the curve may be corrected by adding or subtracting available external static pressure as indicated above.

**Table 7 – Minimum CFM and Motor Speed Selection**

SIZE	HEATER kW									
	3	5	8	9	10	15	18	20	24	30
18	525	525	525	—	600	—	—	—	—	—
24	700	700	700	—	700	775	—	—	—	—
30	—	875	875	—	875	875	—	1060	—	—
36	—	1050	970	970	970	920	—	1040	—	—
42	—	—	1225	1225	1225	1225	1225	1225	—	—
48	—	—	1400	1400	1400	1400	1400	1400	1400	1400
60	—	—	1750	1750	1750	1750	1750	1750	1750	1750

Speed Tap 4 (white wire) is used for electric heat only. White wire must remain on tap 4.

**Table 8 – Estimated Sound Power Level (dBA)\***

SIZE	CONDITIONS		OCTAVE BAND CENTER FREQUENCY						
	CFM	Ext Static Pressure	63	125	250	500	1000	2000	4000
18	600	0.50	70.8	66.8	62.8	59.8	57.8	55.8	51.8
24	800	0.50	72.0	68.0	64.0	61.0	59.0	57.0	53.0
30	1000	0.50	73.0	69.0	65.0	62.0	60.0	58.0	54.0
36	1200	0.50	73.8	69.8	65.8	62.8	60.8	58.8	54.8
42	1400	0.50	74.4	70.4	66.4	63.4	61.4	59.4	55.4
48	1600	0.50	75.0	71.0	67.0	64.0	62.0	60.0	56.0
60	2000	0.50	76.0	72.0	68.0	65.0	63.0	61.0	57.0

\* Estimated sound power levels have been derived using the method described in the 1987 ASHRAE HVAC Systems & Applications Handbook, Chapter 52, p. 52.7.

**PERFORMANCE DATA (cont.)****Table 9 – EH Heater Table**

HEATER PART NO.	kW @ 240V	VOLTS/PH	STAGES (kW OPERATING)	INTERNAL CIRCUIT PROTECTION	FAN COIL SIZE USED WITH	HEATING CAP.* @ 230V
KFFEHE8401N03	3	230/1	3	None	18	9,400
KFFEHE8501N05	5	230/1	5	None	18	15,700
KFFEHE8801N08	8	230/1	8	None	18	25,100
KFFEHE8901N10	10	230/1	10	None	18	31,400
KFFEHE0401N03	3	230/1	3	None	24–25	9,400
KFFEHE0501N05	5	230/1	5	None	24–60	15,700
KFFEHE0801N08	8	230/1	8	None	24–60	25,100
KFFEHE0901N10	10	230/1	10	None	24–60	31,400
KFFEHE3201F20	20	230/1	5, 20	Fuse†	30–60	62,800
KFFEHE8401C05	5	230/1	5	Circuit Breaker	18	15,700
KFFEHE8501C08	8	230/1	8	Circuit Breaker	18	25,100
KFFEHE8601C10	10	230/1	10	Circuit Breaker	18	31,400
KFFEHE2401C05	5	230/1	5	Circuit Breaker	24–60	15,700
KFFEHE2501C08	8	230/1	8	Circuit Breaker	24–60	25,100
KFFEHE2601C10	10	230/1	10	Circuit Breaker	24–60	31,400
KFFEHE3301C20	20	230/1	5, 20	Circuit Breaker	30–60	62,800
KFFEHE2901N09	9	230/1‡	3, 9	None	36–60	28,200
KFFEHE3001F15	15	230/1	5, 15	Fuse†	24–60	47,100
KFFEHE3101C15	15	230/1	5, 15	Circuit Breaker	24–60	47,100
<b>3 Phase Only</b>						
KFFEHE1601315	15	230/3	5, 15	None	36–60	47,100
KFFEHE2001318	18	230/3	6, 12, 18	None	42–60	56,500
<b>3 Phase, Factory Shipped (field convertible to single phase)</b>						
KFFEHE3401F24	24	230/3	8, 16, 24	Fuse	48, 60	78,300
KFFEHE3501F30	30	230/3	10, 20, 30	Fuse	48, 60	94,100

\* Does not include heat from blower motor.

† Single point wiring kit required for these heaters.

‡ Field convertible to 3 phase.

**PERFORMANCE DATA (cont.)****Table 10 – Electrical Data for Units without Electric Heat**

MODEL SIZE	MTR HP	MTR FLA	VOLTS/PH/HZ	SINGLE CIRCUIT		BRANCH CIRCUIT MIN WIRE SIZE* AWG
				MCA	MAXIMUM OVERCURRENT PROTECTION	
18	1/3	2.9	208/230/1/60	3.6	15	14
24	1/3	2.9	208/230/1/60	3.6	15	14
30	1/2	4.2	208/230/1/60	5.3	15	14
36	1/2	4.2	208/230/1/60	5.3	15	14
42	1/2	4.2	208/230/1/60	5.3	15	14
48	3/4	6.1	208/230/1/60	7.6	15	14
60	3/4	6.1	208/230/1/60	7.6	15	14

\* Use copper wire only. Use 75°C only in this application. When using non-metallic (NM) sheathed cable, wire size required should be based on that of 60°C conductors, instead of wire sizes shown in table above per NEC Article 336-26.

NOTE: If branch circuit wire length exceeds 100 ft (30 m), consult NEC 215-2 to determine maximum wire length. Use 2% voltage drop.

FLA - Full Load Amps

SCCR (Short Circuit Current Rating) = 5kA rms, symmetrical, 230V

**HEATER ELECTRICAL DATA****Table 11 – Electric Heater Internal Protection**

HEATER KW	PHASE	FUSE QTY/SIZE	CKT BKR* QTY/SIZE
5	1	—	1/60
8	1	—	1/60
9	1/3	—	—
10	1	—	1/60
15	1	2/30–2/60	2/60
15	3	—	—
18	3	—	—
20	1	4/60	2/60
24	1/3	6/60	—
30	1/3	6/60	—

\* All circuit breakers are 2 pole.

When using units with 20-, 24-, and 30-kW electric heaters, maintain a 1-in. (25mm) clearance from combustible materials to discharge plenum and ductwork and maintain a distance of 36-in (914mm) from the unit. Use an accessory downflow base to maintain proper clearance on downflow installations. Use flexible connectors between ductwork and unit to prevent transmission of vibration. When electric heater is installed, use heat resistant material for flexible connector between ductwork and unit at discharge connection. Ductwork passing through unconditioned space must be insulated and covered with vapor barrier.

**PERFORMANCE DATA (cont.)**

**Table 12 – Accessory Heater Electrical Data**

HEATER PART NO.	kW		P H A S E	INTERNAL CIRCUIT PROTECTION	HEATER AMPS 208/230V			MIN AMPACITY 208/230V*			BRANCH CIRCUIT								
					Single Circuit	Dual Circuit		Single Circuit	Dual Circuit		Min Wire Size (AWG) 208/230V†		Min Gnd Wire Size 208/230V			Max Fuse/Ckt Bkr Amps 208/230V			
	L1,L2	L3,L4				L1,L2	L3,L4		Single Circuit	Dual Circuit L1,L2 L3,L4	Single Circuit	Dual Circuit L1,L2 L3,L4	Single Circuit	Dual Circuit L1,L2 L3,L4	Single Circuit	Dual Circuit L1,L2 L3,L4			
KFFE0401N03A	3	2.3	1	None	10.9/12.0	—	—	17.3/18.6	—	—	12/12	—	—	12/12	—	—	20/20	—	—
KFFE0840N03A	3	2.3	1	None	10.9/12.0	—	—	17.3/18.6	—	—	12/12	—	—	12/12	—	—	20/20	—	—
KFFE0501N05A‡	5	3.8	1	None	18.1/20.0	—	—	26.0/28.4	—	—	10/10	—	—	10/10	—	—	30/30	—	—
KFFE08501N05A	5	3.8	1	None	18.1/20.0	—	—	26.3/28.6	—	—	10/10	—	—	10/10	—	—	30/30	—	—
KFFE08501C05A	5	3.8	1	None	18.1/20.0	—	—	26.3/28.6	—	—	10/10	—	—	10/10	—	—	30/30	—	—
KFFE0501N05A**	5	3.8	1	None	18.1/20.0	—	—	31.2/33.5	—	—	8/8	—	—	10/10	—	—	35/35	—	—
KFFE02401C05A**	5	3.8	1	Ckt Bkr	18.1/20.0	—	—	31.2/33.5	—	—	8/8	—	—	10/10	—	—	35/35	—	—
KFFE0801N08A	8	6.0	1	None	28.9/32.0	—	—	44.7/48.5	—	—	8/8	—	—	10/10	—	—	45/50	—	—
KFFE08801N08A	8	6.0	1	None	28.9/32.0	—	—	39.8/43.6	—	—	8/8	—	—	10/10	—	—	45/50	—	—
KFFE08501C08A	8	6.0	1	None	28.9/32.0	—	—	39.8/43.6	—	—	8/8	—	—	10/10	—	—	45/50	—	—
KFFE02501C08A	8	6.0	1	Ckt Bkr	28.9/32.0	—	—	44.7/48.5	—	—	8/8	—	—	10/10	—	—	45/50	—	—
KFFE02901N09A	9	6.8	1	None	32.8/36.0	—	—	49.5/53.5	—	—	8/6	—	—	10/10	—	—	50/60	—	—
KFFE02901N09A††	9	6.8	3	None	18.8/20.8	—	—	32.0/34.5	—	—	8/8	—	—	10/10	—	—	35/35	—	—
KFFE0901N10A	10	7.5	1	None	36.2/40.0	—	—	53.8/58.5	—	—	6/6	—	—	10/10	—	—	60/60	—	—
KFFE08901N10A	10	7.5	1	None	36.2/40.0	—	—	48.9/53.6	—	—	6/6	—	—	10/10	—	—	60/60	—	—
KFFE08601C10A	10	7.5	1	None	36.2/40.0	—	—	48.9/53.6	—	—	6/6	—	—	10/10	—	—	60/60	—	—
KFFE02601C10A	10	7.5	1	Ckt Bkr	36.2/40.0	—	—	53.8/58.5	—	—	6/6	—	—	10/10	—	—	60/60	—	—
KFFE03001F15A‡‡	15	11.3	1	Fuse	54.2/59.9	36.2/40.0	18.1/20.0	76.3/83.4	53.8/58.5	22.7/25.0	4/4	6/6	10/10	8/8	10/10	10/10	80/90	60/60	25/25
KFFE03101C15A	15	11.3	1	Ckt Bkr	—	36.2/40.0	18.1/20.0	—	53.8/58.5	22.7/25.0	—	6/6	10/10	—	10/10	10/10	—	60/60	25/25
KFFE01601315A	15	11.3	3	None	31.3/34.6	—	—	47.7/51.8	—	—	8/6	—	—	10/10	—	—	50/60	—	—
KFFE02001318A	18	13.5	3	None	37.6/41.5	—	—	55.5/60.4	—	—	6/6	—	—	10/8	—	—	60/70	—	—
KFFE03201F20A‡‡	20	15.0	1	Fuse	72.3/79.9	36.2/40.0	36.2/40.0	98.9/108.4	53.8/58.5	45.3/50.0	3/2	6/6	8/8	8/6	10/10	10/10	100/110	60/60	50/50
KFFE03301C20A	20	15.0	1	Ckt Bkr	—	36.2/40.0	36.2/40.0	—	53.8/58.5	45.3/50.0	—	6/6	8/8	—	10/10	10/10	—	60/60	50/50
KFFE03401F24A***	24	18.0	3	Fuse	50.1/55.4	—	—	71.2/77.8	—	—	4/4	—	—	8/8	—	—	80/80	—	—
	24	18.0	1	Fuse	86.7/95.5	—	—	116.9/127.9	—	—	1/1	—	—	6/6	—	—	125/150	—	—
KFFE03501F30A***	30	22.5	3	Fuse	62.6/69.2	—	—	86.8/95.0	—	—	3/3	—	—	8/8	—	—	90/100	—	—
	30	22.5	1	Fuse	109.0/120.0	—	—	144.8/158.5	—	—	0/00	—	—	6/6	—	—	150/175	—	—

\*. Includes blower motor amps of largest fan coil used with heater.  
 †. Copper wire must be used. If other than uncoated (non-plated), 75°C ambient, copper wire (solid wire for 10 AWG and smaller, stranded wire for larger than 10 AWG) is used, consult applicable tables of the NEC (ANSI/NFPA 70).  
 ‡. For fan coil sizes 24–42.  
 \*\*. For fan coil sizes 48–60.  
 ††. Field convertible to 3 phase.  
 ‡‡. Single circuit application of F15 and F20 heaters requires single-point wiring kit accessory.  
 \*\*\*. Field convertible to 1 phase, single or multiple supply circuit.

**Table 13 – Field Multipoint Wiring or 24- and 30-kW Single Phase**

HEATER PART NO.	kW		PHASE	HEATER AMPS 208/230V			MIN AMPACITY 208/230V*			MIN WIRE SIZE (AWG) 208/230V†			MIN GND WIRE SIZE 208/230V	MAX FUSE/CKT BKR AMPS 208/230V			MAX WIRE LENGTH 208/230V (FT)‡		
	240V	208V		L1,L2	L3,L4	L5,L6	L1,L2	L3,L4	L5,L6	L1,L2	L3,L4	L5,L6		L1,L2	L3,L4	L5,L6	L1,L2	L3,L4	L5,L6
KFFE03401F24**	24	18.0	1	28.9/32.0	28.9/32.0	28.9/32.0	44.7/48.5	36.2/40.0	36.2/40.0	8/8	8/8	8/8	10/10	45/50	40/40	40/40	59/60	73/73	73/73
KFFE03501F30	30	22.5	1	36.2/40.0	36.2/40.0	36.2/40.0	53.8/58.5	45.3/50.0	45.3/50.0	6/6	8/8	8/8	10/10	60/60	50/50	50/50	78/80	59/59	59/59

\*. Includes blower motor amps of largest fan coil used with heater.  
 †. Copper wire must be used. If other than uncoated (non-plated), 75°C ambient, copper wire (solid wire for 10 AWG and smaller, stranded wire for larger than 10 AWG) is used, consult applicable tables of the NEC (ANSI/NFPA 70).  
 ‡. Length shown is as measured 1 way along wire path between unit and service panel for a voltage drop not to exceed 2%.  
 \*\*. Field convertible to 1 phase, single or multiple supply circuit.

15 Manufacturer reserves the right to change, at any time, specifications and designs without notice and without obligations.

**Table 14 – Accessories**

	ITEM	ACCESSORY PART NO.*	FAN COIL SIZE USED WITH
1.	Disconnect Kit	KFADK0301DSC	All single phase 3kW - 10kW heaters
2.	Downflow Base Kit	KFACB0101CFB	18
		KFACB0201CFB	24, 30, 36
		KFACB0301CFB	42, 48
		KFACB0401CFB	60
3.	Downflow Conversion Kit †	KFADC0201SLP	Slope Coil Units—18, 24
		KFADC0401ACL	A-Coil Units—30, 36, 42, 48, 60
4.	Downflow/Horizontal Conversion Gasket Kit	KFAHD0101SLP	All
5.	Horizontal Water Management Kit (25 pack) ‡	KFAHC0125AAA	A-Coil Units—30, 36, 42, 48, 60
6.	Single-Point Wiring Kit	KFASP0101SPK	Only with 15- and 20-kW Fused Heaters
7.	Filter Kit (12 Pack)	KFAFK0112SML	18
		KFAFK0212MED	24, 30, 36
		KFAFK0312LRG	042, 48
		KFAFK0412XXL	60
8.	Fan Coil Filter Cabinet (Fan Coil Filter Media)	FNCCABCC0014 (FILXXFNC0014)	18
		FNCCABCC0017 (FILXXFNC0017)	24, 30, 36
		FNCCABCC0021 (FILXXFNC0021)	42, 48
		FNCCABCC0024 (FILXXFNC0024)	60
9.	PVC Condensate Trap Kit (50 pack)	KFAET0150ETK	All
10.	Air Cleaner 240-volt Conversion Kit	KEAVC0201240	All
11.	Standard Filter Rack Kit	KFAFR0101FRM	18
		KFAFR0201FRM	24, 30, 36
		KFAFR0301FRM	42, 48
		KFAFR0401FRM	60
12.	TXV Kit, Puron (R-410A), Aluminum Coils Only	KSBTX0201PUR	18L, 24L, 30L, 36L, 42L
		KSBTX0301PUR	48L
		KSBTX0401PUR	60L
		KSBTX0501PUR	60L
13.	Door Gasket Kit **	344994-751	All
14.	Accessory Quick Connect Kit	KFAPS0110KIT	All

\* Factory authorized and listed, field-installed.

\*\* This kit is for replacement of factory installed gaskets if they are damaged or removed from the fan coil.

† KFAHD0101SLP must also be purchased for down flow applications.

‡ KFAHD0101SLP must also be purchased for down flow or horizontal applications.



## Accessory Kits Description – Suggested and Required Use

### 1. Disconnect Kit

The kit is used to disconnect electrical power to the fan coil so service or maintenance may be performed safely.

SUGGESTED USE: Units for 3- through 10-kW electric resistance heaters and cooling controls.

### 2. Downflow Base Kit

This kit is designed to provide a 1-in. (25mm) minimum clearance between unit discharge plenum, ductwork, and combustible materials. It also provides a gap-free seal with the floor.

REQUIRED USE: This kit must be used whenever fan coils are used in downflow applications.

### 3. Downflow Conversion Kit

Fan coils are shipped from the factory for upflow or horizontal-left applications. Downflow conversion kits provide proper condensate water drainage and support for the coil when used in downflow applications. Separate kits are available for slope coils and A-coils.

REQUIRED USE: This kit must be used whenever fan coils are used in downflow applications.

### 4. Downflow/Horizontal Conversion Gasket Kit

This kit provides the proper gasketing of units when applied in either a downflow or horizontal application.

REQUIRED USE: Fan coils in either downflow or horizontal applications.

### 5. Horizontal Applications - Water Management Kit

This kit provides proper installation of fan coils under conditions of high static pressure and high relative humidity.

SUGGESTED USE: All fan coils.

### 6. Single Point Wiring Kit

The single point wiring kit acts as a jumper between L1 and L3 lugs, and between the L2 and L4 lugs. This allows the installer to run two heavy-gauge, high-voltage wires into the fan coil rather than 4 light-gauge, high-voltage wires.

SUGGESTED USE: Fan coils with 15- and 20-kW fused heaters only.

### 7. Filter Kit (12 pack)

The kit consists of 12 fan coil framed filters. These filters collect large dust particles from the return air entering the fan coil and prevents them from collecting on the coil. This process helps to keep the coil clean, which increases heat transfer and, in turn, the efficiency of the system.

SUGGESTED USE: To replace filters in fan coils.

REQUIRED USE: All units unless a filter grille is used.

### 8. Fan Coil Filter Cabinet

This cabinet is mounted to the fan coil on the return air end and designed to slip over the outer fan coil casing. The cabinets are insulated using the same insulation as production fan coils. They are designed for the removal of particulates from indoor air using FILXXFNC00(14, 17, 21, 24) media filter cartridges. These fan coil media filter cartridge kits are designed for the removal of particles from indoor air. The cartridge is installed in the return air duct next to the air handler or further upstream.

SUGGESTED USE: All fan coils.

### 9. PVC Condensate Drain Trap Kit

This kit consists of 50 PVC condensate traps. Each trap is pre-formed and ready for field installation. This deep trap helps the system make and hold proper condensate flow even during blower initiation.

SUGGESTED USE: All fan coils.

### 10. Air Cleaner 240-volt Conversion Kit

The AIRA electronic air cleaner comes ready for 115-v operation.

REQUIRED USE: This kit is required when running 240-volt circuit to air cleaner.

### 11. Standard Filter Rack Kit

This kit mounts in fan coil filter rack area and modifies the existing filter rack to support standard 1-in. filter sizes.

SUGGESTED USE: Fan coils using standard filter sizes.

### 12. TXV Kit

These kits are designed to add TXVs to piston fan coils or convert Puron (R-410A) fan coils to R-22 TXVs.

### 13. Door Gasket Kit

This kit consists of specific adhesive-backed foam strips which are applied to the unit door and frame, limiting air leakage.

### 14. Accessory Quick Connect Kit

This kit enables the installer to easily connect a 230 volt IAQ accessory (air purifier, electronic air cleaner, UV light, etc.) kit to a fan coil unit, eliminating the need to run a separate power supply to the accessory. Use of this kit may eliminate the requirement for a licensed electrician to complete the job (check local codes).