

## 50ZHK

### 14 SEER Single Packaged Heat Pump System with Puron® (R-410A) Refrigerant Single Phase 2 to 5 Nominal Tons (024-060)



Turn to the experts

## Product Data

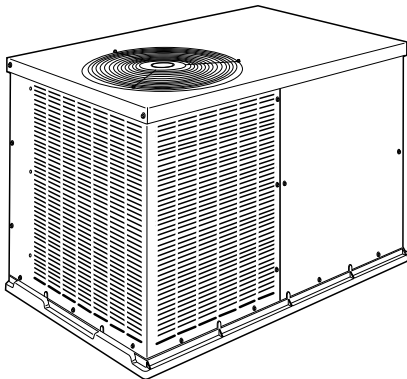

024-036 Size

A10165

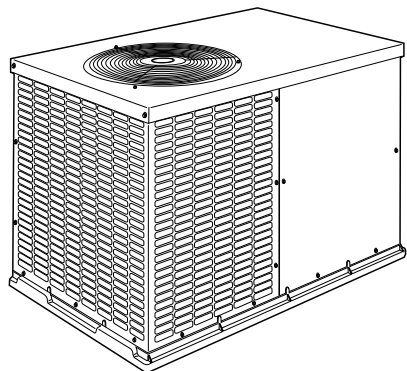

042-060 Size

A150067

**Fig. 1 – Unit 50ZHK**

Single-Packaged Heat Pump Units with:

- Easy installation design
- Corrosion-proof unit base
- Class leading sound ratings
- Sloped drain for improved indoor air quality
- Scroll compressors
- Front and side service access
- Louvered panel coil protection
- Aluminum coil
- Cabinet air leakage less than 2.0% at 1.0 in. W.C. and cabinet air leakage less than 1.4% at 0.5 in. W.C. when tested in accordance with ASHRAE standard 193

### Features/Benefits

This unit is a packaged heat pump for manufactured housing, residential, and light commercial applications. Factory assembled package is a compact, horizontal supply and return unit, combining easy installation and maintenance with efficient performance.

**EASY TO INSTALL**—The units are lightweight, compact single package units that are easy to handle. Every size unit has an identical 32

by 51-in. (813 by 1295 mm) footprint to make job site planning simple. The efficient design uses less sheet metal and makes this unit lighter than competitive units. The unit can be easily positioned on the job site with the hand-holds built into the unit basepan.

**AERODYNAMIC FAN BLADE DESIGN** reduces overall sound by up to 3dBA; as low as 72dBA.

**SERVICE ACCESS**—The units are designed to be serviced from both front and side. Routine maintenance tasks, such as coil cleaning, are sped up with the multiple side panels design.

**CORROSION PROOF UNIT BASE**—The unit features a tough, high-tech, single-piece composite material unit base with an integrated drain. The composite material eliminates the potential problem of rust and premature replacement which are common with standard metal pans. Each unit base is sloped to eliminate standing water. This feature minimizes the amount of standing water inside the unit, which limits mold and mildew growth.

**DURABLE STEEL CABINET**—The watertight construction and corrosion-resistant finish will keep it looking like new for years. A specialized paint treatment process ensures quality protection against the elements. A compact, low-profile design utilizes a louvered coil enclosure for maximum protection against hail damage and vandalism.

**SCROLL COMPRESSORS**—Each unit comes standard with a scroll compressor. Each scroll compressor is hermetically sealed against contamination to help promote longer life and dependable operation. All scroll compressors have internal high-pressure and overcurrent protection.

**COIL EFFICIENCY**—Indoor and outdoor coils are computer designed for optimum heat transfer and cooling efficiency.

**DEFROST SYSTEM**—The system provides time/ temperature-based defrost cycles to maintain unit efficiency. This highly reliable system monitors coil temperature and initiates a defrost cycle only if it is required. The defrost cycle ends as soon as defrosting is complete.

**ACCESSORY ELECTRIC HEATERS**—A variety of accessory electric heaters are available for these units. These heaters are comprised of a separate heater module mounted on the blower inlet and remote mounted controls located in the unit control box. Single point electrical connections are provided for powering both the heater and the unit.

**START COLLARS**—Start collars are provided with each unit to provide easy connection to the structure ductwork.

**DEPENDABLE COMPONENTS**—Direct-drive, multi-speed blower motor is standard on all models.

**DIRECT-DRIVE, PSC OUTDOOR-FAN MOTORS** are designed to help reduce energy consumption and provide for cooling operation down to 40°F (4.4°C). It's high efficiency design ensures high performance with most duct systems.

**REFRIGERANT SYSTEM** is designed to provide dependability. Liquid refrigerant filter driers are used to promote clean, unrestricted operation. Each unit leaves the factory with a full refrigerant charge and is fully run tested. Refrigerant service connections make checking operating pressure easier.

## Model Number Nomenclature

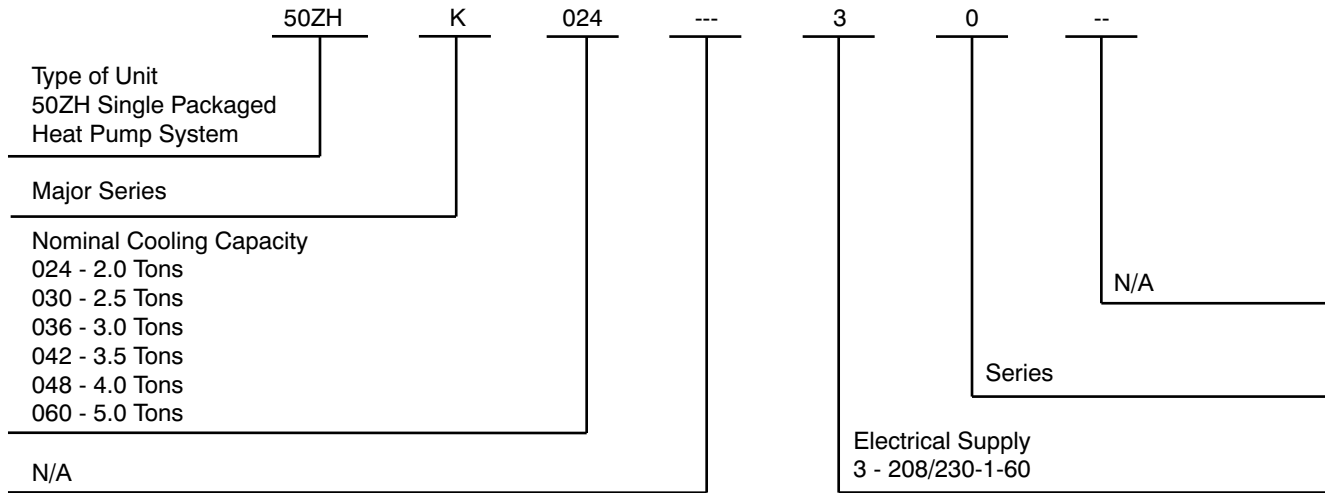

## Table of Contents

Features/Benefits . . . . .	1
Model Number Nomenclature . . . . .	2
AHRI Capacities . . . . .	3
Base Unit Dimensions—024-036 . . . . .	6
Base Unit Dimensions — 042-060 . . . . .	7
Selection Procedure . . . . .	8
Performance Data . . . . .	10
Typical Installation . . . . .	26
Typical Connection Wiring Schematic . . . . .	27
Controls . . . . .	29
Application Data . . . . .	29
Guide Specifications . . . . .	30
General . . . . .	30
Products . . . . .	30

**AHRI\* Capacities****Cooling Capacities and Efficiencies**

UNIT SIZE	NOMINAL TONS	STANDARD CFM	NET COOLING CAPACITY (Btuh) <sup>†**</sup>	NET COOLING CAPACITY (Btuh) <sup>††</sup>	EER <sup>†**</sup>	EER2 <sup>††</sup>	SEER <sup>†**</sup>	SEER2 <sup>††</sup>
024	2	800	23,600	24,000	11.50	10.6	14.00	13.4
030	2.5	1000	29,800	28,600	11.50	10.6	14.00	13.4
036	3	1200	35,800	35,000	11.50	10.6	14.50	13.4
042	3.5	1400	41,000	40,000	11.50	10.6	14.00	13.4
048	4	1600	46,500	45,500	11.50	10.6	14.00	13.4
060	5	1850	55,000	54,000	11.00	10.6	14.00	13.4

\* Air Conditioning Heating &amp; Refrigeration Institute

†. Rated in accordance with U.S. Government DOE (Department of Energy) Appendix M1 test procedures and/or AHRI 210/240.

†. At "A" conditions --80°F (26.7°C) indoor db/67°F (19.4°C) indoor wb &amp; 95°F (35°C) outdoor db.

\*\*. Rated in accordance with U.S. Government DOE (Department of Energy) Appendix M test procedures and/or AHRI Standards 210/240.

EER - Energy Efficiency Ratio

SEER - Seasonal Energy Efficiency Ratio

NOTES:

1. Ratings are net values, reflecting the effects of circulating fan heat.

2. Before purchasing this appliance, read important energy cost and efficiency information available from your retailer.

**Heat Pump Heating Capacities and Efficiencies**

UNIT SIZE	NET HEATING CAPACITY AT 47°F (8.3°C) (Btuh) <sup>*</sup>	NET HEATING CAPACITY AT 47°F (8.3°C) (Btuh) <sup>†</sup>	COP @ 47°F (8.3°C) <sup>*</sup>	COP @ 47°F (8.3°C) <sup>†</sup>	NET HEATING CAPACITY AT 17°F (-8.3°C) (Btuh) <sup>*</sup>	NET HEATING CAPACITY AT 17°F (-8.3°C) (Btuh) <sup>†</sup>	COP @ 17°F (-8.3°C) <sup>*</sup>	COP @ 17°F (-8.3°C) <sup>†</sup>	HSPF <sup>*</sup>	HSPF2 <sup>†</sup>
024	24,000	24,000	3.7	3.7	13,000	13,300	2.3	2.2	8.0	6.7
030	28,600	28,600	3.7	3.7	14,500	14,800	2.2	2.1	8.0	6.7
036	32,000	32,200	3.5	3.4	20,600	20,800	2.5	2.5	8.0	6.7
042	40,000	40,000	3.5	3.4	23,800	24,000	2.5	2.4	8.0	6.7
048	45,000	45,000	3.5	3.4	26,400	26,800	2.4	2.4	8.0	6.7
060	56,000	56,000	3.5	3.4	33,200	33,600	2.4	2.4	8.0	6.7

\* Rated in accordance with U.S. Government DOE (Department of Energy) Appendix M test procedures and/or AHRI Standards 210/240.

†. Rated in accordance with U.S. Government DOE (Department of Energy) Appendix M1 test procedures and/or AHRI 210/240

COP - Coefficient of Performance

HSPF - Heating Seasonal Performance Factor

Notes:

1. Ratings are net values, reflecting the effects of circulating fan heat

2. Before purchasing this appliance, read important energy cost and efficiency information available from your retailer.



Use of the AHRI Certified TM Mark indicates a manufacturer's participation in the program For verification of certification for individual products, go to [www.ahridirectory.org](http://www.ahridirectory.org).

**A-Weighted Sound Power Level (dBA)**

UNIT SIZE	STANDARD RATING (dBA*)	TYPICAL OCTAVE BAND SPECTRUM (Dba without tone adjustment)						
		125	250	500	1000	2000	4000	8000
24	72	62	63	64	68	63	54	47
30	72	68	62	65	66	60	53	49
36	77	66	70	73	75	69	64	55
42	76	63	68	70	72	66	61	55
48	77	74	68	70	71	67	61	54
60	79	68	67	74	75	71	66	60

68LEGENDD

dB68A - Sound Levels (decibels "A" weighting)

NOTE: Tested in accordance with AHRI Standard 270-1995 (not listed in AHRI).

## Physical Data

UNIT SIZE	024	030	036	042	048	060
NOMINAL CAPACITY (ton)	2	2.5	3	3.5	4	5
SHIPPING WEIGHT (lb)	312	333	334	388	407	475
(kg)	142	151	152	177	185	215
COMPRESSOR TYPE	SCROLL					
REFRIGERANT	R-410A					
REFRIGERANT QUANTITY (lb)	6.3	9.8	6.8	7.7	9.0	12.0
QUANTITY (kg)	2.9	3.1	3.1	3.5	4.1	5.4
OUTDOOR METERING DEVICE	TXV	Piston			TXV	Piston
ORIFICE ID (in.)	-	0.055	0.057	0.059	-	0.070
(mm)	-	1.397	1.448	1.499	-	1.778
OUTDOOR COIL						
ROWS...FINS/in.	1...20	1...20	2...20	2...20	2...20	2...20
FACE AREA (sq. ft)	9.1	9.1	9.1	10.2	13.0	15.5
OUTDOOR FAN						
NOMINAL AIRFLOW (CFM)	2000	2000	2800	3100	3100	3300
DIAMETER (in.)	20	20	20	20	20	20
DIAMETER (mm)	508	508	508	508	508	508
MOTOR HP (RPM)	1/8 (825)	1/8 (825)	1/4 (1100)	1/4 (1100)	1/4 (1100)	1/3 (1100)
INDOOR METERING DEVICE	Piston				TXV	TXV
ORIFICE ID (in.)	0.057	0.063	0.067	0.076	-	-
(mm)	1.448	1.600	1.702	1.930	-	-
INDOOR COIL						
ROWS...FINS/in.	2...12	3...15	3...15	3...15	3...15	3...15
FACE AREA (sq. ft)	4.3	4.3	4.3	4.9	4.9	6.1
INDOOR BLOWER						
NOMINAL COOLING AIRFLOW (CFM)	800	1000	1200	1400	1600	1850
NOMINAL SIZE D x L (in.)	8 x 11	8 x 11	9 x 12	9 x 12	11 x 12	11 x 12
(mm)	254 x 203	254 x 203	279 x 229	279 x 229	279 x 229	267 x 305
MOTOR (HP)	1/3	1/2	1/2	1/2	3/4	1
HIGH-PRESSURE SWITCH (psig)						
CUTOUT	650 +/- 15					
RESET (AUTO)	420 +/- 25					
LOW-PRESSURE SWITCH (psig)						
CUTOUT	20 +/- 5					
RESET (AUTO)	45 +/- 10					
RETURN-AIR FILTERS*						
THROWAWAY (in.)	20x20x1	20x24x1	24x30x1	24x36x1		
(mm)	508x508x25	508x610x25	610x762x25	610x914x25		

\*. Required filter sizes shown are based on the AHRI (Air Conditioning, Heating & Refrigeration Institute) rated airflow at a velocity of 300 ft/min (91 m) for throwaway type or 450 ft/min (137 m) for high capacity type. Recommended filters are 1-in. (25 mm) thick.

**Accessories**

DESCRIPTION	USED WITH	PART NUMBER
Compressor Start Kit	All	CPHSTART002A00
240V Crankcase Heater	24-36	CPCRKHTR008A00
	42-60	CPCRKHTR004A00
Low Ambient Control	All	CPLOWAMB001A00

**Accessory Electric Heater Usage**

CATALOG ORDERING NO.	NOMINAL CAPACITY (kW)	CIRCUIT BREAKER (Yes/No)	STAGES	USED WITH SIZES					
				024	030	036	042	048	060
CPHEATER125A0*	3.8 / 5.0	No	1	✓	✓	✓	✓		
CPHEATER126A0*	3.8 / 5.0	Yes	1	✓	✓	✓	✓	✓	✓
CPHEATER127A0*	5.6 / 7.5	No	2	✓					
CPHEATER128A0*	5.6 / 7.5	Yes	2	✓	✓	✓	✓	✓	✓
CPHEATER130A0*	7.5 / 10.0	Yes	2	✓	✓	✓	✓	✓	✓
CPHEATER131A0*	11.3 / 15.0	Yes	2			✓	✓	✓	✓
CPHEATER132A0*	15.0 / 20.0	Yes	2					✓	✓

✓ Approved combination

**Multiplication Factors**

HEATER kW RATING	VOLTAGE DISTRIBUTION	MULTIPLICATION FACTOR
240	200	.69
	208	.75
	230	.92
	240	1.00

Example: 15.0 kW (at 240v) heater on 208v  
= 15.0 (.75 mult factor)  
= 11.25 capacity at 208v

# Base Unit Dimensions—024-036

UNIT	ELECTRICAL CHARACTERISTICS			UNIT WT.			UNIT HEIGHT			CENTER OF GRAVITY IN [MM]		
	LBS.	KG.	A	X	Y	Z	RETURN	SUPPLY	CG	X	Y	Z
50ZHK024---30	253	115	30-1/8 [765]	14 [356]	19 [483]	14 [356]	14 [356]	14 [356]	19 [483]	14 [356]	14 [356]	14 [356]
50ZHK030---30	283	128	34-1/8 [867]	14 [356]	19 [483]	16 [406]	14 [356]	14 [356]	19 [483]	16 [406]	16 [406]	16 [406]
50ZHK036---30	285	130	34-1/8 [867]	14 [356]	19 [483]	16 [406]	14 [356]	14 [356]	19 [483]	16 [406]	16 [406]	16 [406]

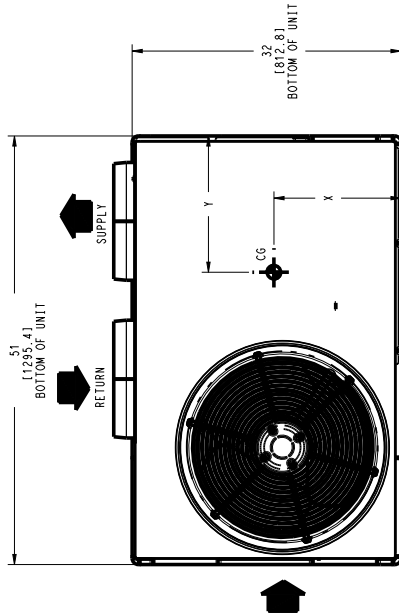

TOP VIEW

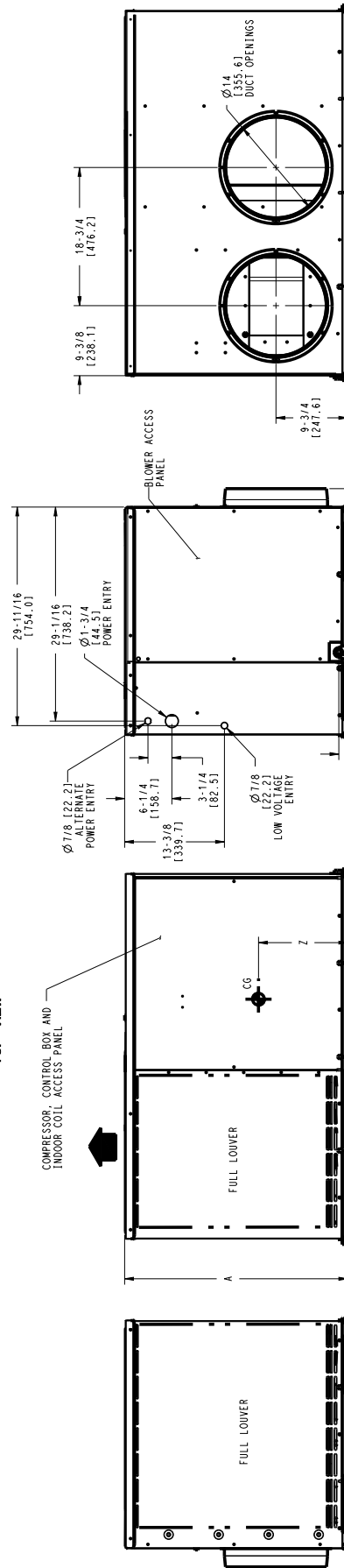

LEFT SIDE VIEW

FRONT VIEW

RIGHT SIDE VIEW

REAR VIEW

DIMENSIONS IN [ ] ARE IN MM

**REQUIRED CLEARANCES TO COMBUSTIBLE MATL.**

TOP OF UNIT.....	INCHES [MM]
BOTTOM OF UNIT.....	0
SIDE OF UNIT WITH DUCT OPENINGS.....	0
SIDE OF UNIT OPPOSITE DUCT OPENINGS.....	0

**NEC REQUIRED CLEARANCES.**

BETWEEN UNITS, POWER ENTRY SIDE.....	INCHES [MM]
UNIT AND UNGROUND SURFACES, POWER ENTRY SIDE.....	42.0 [1067]
UNIT AND UNGROUND SURFACES, POWER ENTRY SIDE, OTHER THAN POWER ENTRY SIDE.....	36.0 [914]
GROUND SURFACES, POWER ENTRY SIDE.....	42.0 [1067]

**REQUIRED CLEARANCE FOR SERVICING**

TOP OF UNIT.....	INCHES [MM]
SIDE OF UNIT OPPOSITE DUCT OPENINGS.....	30.0 [762]
SIDE OF UNIT WITH POWER ENTRY.....	30.0 [762]
(EXCEPT FOR NEC REQUIREMENTS)	30.0 [762]

NOTE: CLEARANCES MUST BE MAINTAINED TO PREVENT RECIRCULATION OF AIR FROM OUTDOOR FAN DISCHARGE. A REMOVABLE FENCE OR BARRICADE REQUIRES NO CLEARANCE.

348132-4

# Base Unit Dimensions — 042-060

UNIT	ELECTRICAL CHARACTERISTICS		UNIT HEIGHT		CENTER OF GRAVITY IN (MM)		
	LB	KG	A	X	Y	Z	
50ZHK042---30	338	154	42-1/8 (1070)	14 (356)	19 (483)	19-3/4 (503)	
50ZHK048---30	358	163	42-1/8 (1070)	14 (356)	19 (483)	19-3/4 (503)	
50ZHK060---30	425	193	42-1/8 (1070)	14 (356)	19 (483)	19-3/4 (503)	

**REQUIRED CLEARANCES TO COMBUSTIBLE MATL.**

TOP OF UNIT..... INCHES (MM) 0  
 BOTTOM OF UNIT..... INCHES (MM) 0  
 SIDE OF UNIT WITH DUCT OPENINGS..... INCHES (MM) 0  
 SIDE OF UNIT OPPOSITE DUCT OPENINGS..... INCHES (MM) 0

**NEC REQUIRED CLEARANCES**

BETWEEN UNITS, POWER ENTRY SIDE..... INCHES (MM) 42.0 (1067)  
 UNIT AND UNROUNDED SURFACES, POWER ENTRY SIDE..... INCHES (MM) 36.0 (914)  
 UNIT AND BLOCK OR CONCRETE WALLS AND OTHER GROUNDED SURFACES, POWER ENTRY SIDE..... INCHES (MM) 36.0 (914)

**REQUIRED CLEARANCE FOR SERVICING**

TOP OF UNIT..... INCHES (MM) 36.0 (914)  
 SIDE OF UNIT OPPOSITE DUCT OPENINGS..... INCHES (MM) 36.0 (914)  
 SIDE OF UNIT WITH POWER ENTRY..... INCHES (MM) 30.0 (762)  
 (EXCEPT FOR NEC REQUIREMENTS)

**NOTE: CLEARANCES MUST BE MAINTAINED TO PREVENT RECIRCULATION OF AIR FROM OUTDOOR FAN DISCHARGE. A REMOVABLE FENCE OR BARRICADE REQUIRES NO CLEARANCE.**

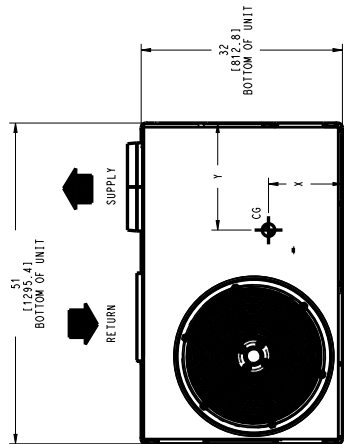

TOP VIEW

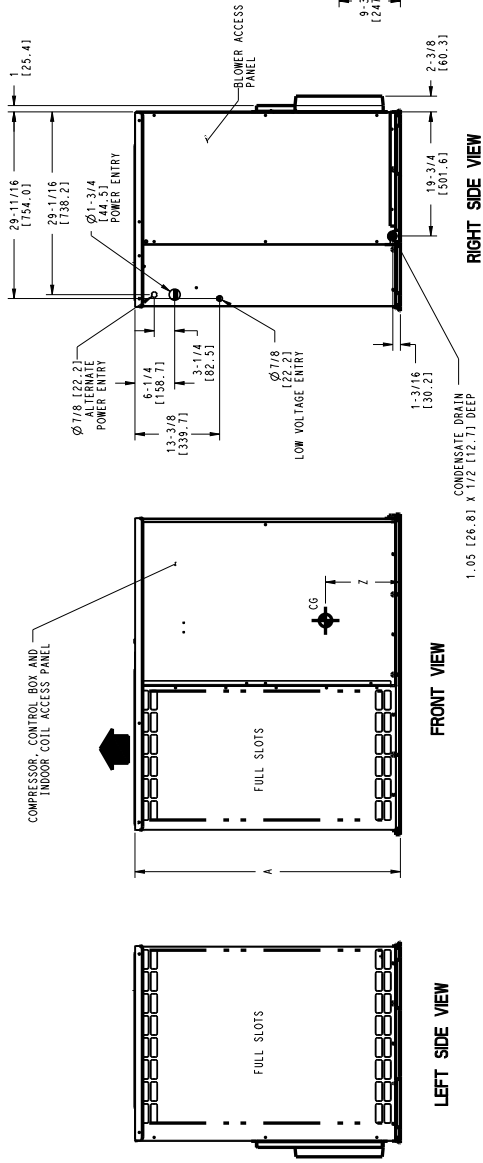

FRONT VIEW

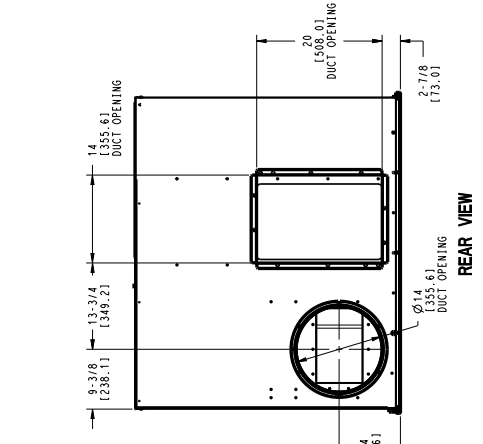

REAR VIEW

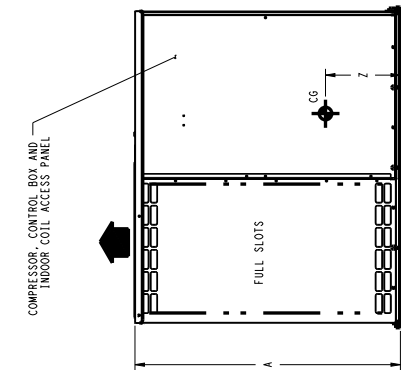

RIGHT SIDE VIEW

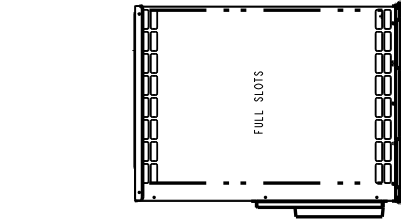

LEFT SIDE VIEW

DIMENSIONS IN ( ) ARE IN MM

348133-4

## Selection Procedure

### DETERMINE COOLING AND HEATING REQUIREMENTS AT DESIGN CONDITIONS

Given:

Required Cooling Capacity (TC).....	28,000
Sensible Heat Capacity (SHC).....	20,500 Btuh
Required Heating Capacity.....	28,550 Btuh
Outdoor Entering-Air Temperature.....	95°F (35°C)
Outdoor-Air Winter Design Temperature.....	20°F (-6.7°C)
Indoor-Air Winter Design Temperature.....	70°F (21.1°C)
Indoor Entering-Air Temperature	80°F (26.7°C) edb, 67°F ewb (19.4°C)
Indoor-Air Quantity.....	1000 CFM
External Static Pressure.....	0.20 IN. W.C.
Electrical Characteristics (V-Ph-Hz).....	230-1-60

edb — entering dry bulb  
ewb — entering wet bulb

### SELECT UNIT BASED ON REQUIRED COOLING CAPACITY

Enter Cooling Capacities table at condenser entering temperature of 95°F (35°C), indoor air entering at 1000 CFM and 67°F (19.4°C) ewb (entering wet bulb). The 030 unit will provide a total cooling capacity of 28,800 Btuh and a sensible heat capacity of 21,600 Btuh.

For indoor-air temperature other than 80°F edb (entering dry bulb), calculate sensible heat capacity correction, as required, using the formula found in Note 3 following the cooling capacities tables.

**NOTE:** Unit ratings are net capacities.

### SELECT ELECTRIC HEAT

Enter the 030 Heating Capacities table at 1000 CFM. At 70°F (21.1°C) return indoor air and 20°F (-6.7°C) air entering outdoor coil, the integrated heating capacity is 16,740 Btuh. (Select integrated heating capacity value since deductions for outdoor-coil frost and defrosting have already been made. No correction is required.)

The required heating capacity is 28,550 Btuh. Therefore, 11,810 Btuh (28,550 - 16,740) additional electric heat is required.

Determine additional electric heat capacity in kW.

$$\frac{11,810 \text{ Btuh}}{3414 \text{ Btuh/kW}} = 3.46 \text{ kW of heat required}$$

Enter the Accessory Electric Heater Usage table on page 5 for 208/240v. single-phase, 030 unit. The 5-kW heater at 240v most closely satisfies the heating required. To calculate kW at 230v, multiply the heater kW by multiplication factor 0.92 found in the Multiplication Factors table on page 5.

$$5 \text{ kW} \times 0.92 = 4.6 \text{ kW}$$

$$4.6 \times 3414 = 15,704 \text{ Btuh}$$

To calculate kW at 208 v, see Multiplication Factors table on page 5.

Total unit heating capacity is 32,444 Btuh (16,740 +15,704).

### DETERMINE FAN SPEED AND POWER REQUIREMENTS AT DESIGN CONDITIONS

Before entering the air delivery tables, calculate the total static pressure required. From the given, the Accessory Electric Heat Pressure Drop table, and the Filter Pressure Drop table, find:

External static pressure	0.20 IN. W.C.
Filter	0.09 IN. W.C.
Electric heat	<u>0.04 IN. W.C.</u>
Total static pressure	0.33 IN. W.C.

Enter the table for Dry Coil Air Delivery — Horizontal Discharge at 1000 CFM and 230v high speed. The blower will deliver 1036 CFM @ 0.40 IN W.C. static pressure. This will adequately handle job requirements.



# BALANCE POINT WORKSHEET

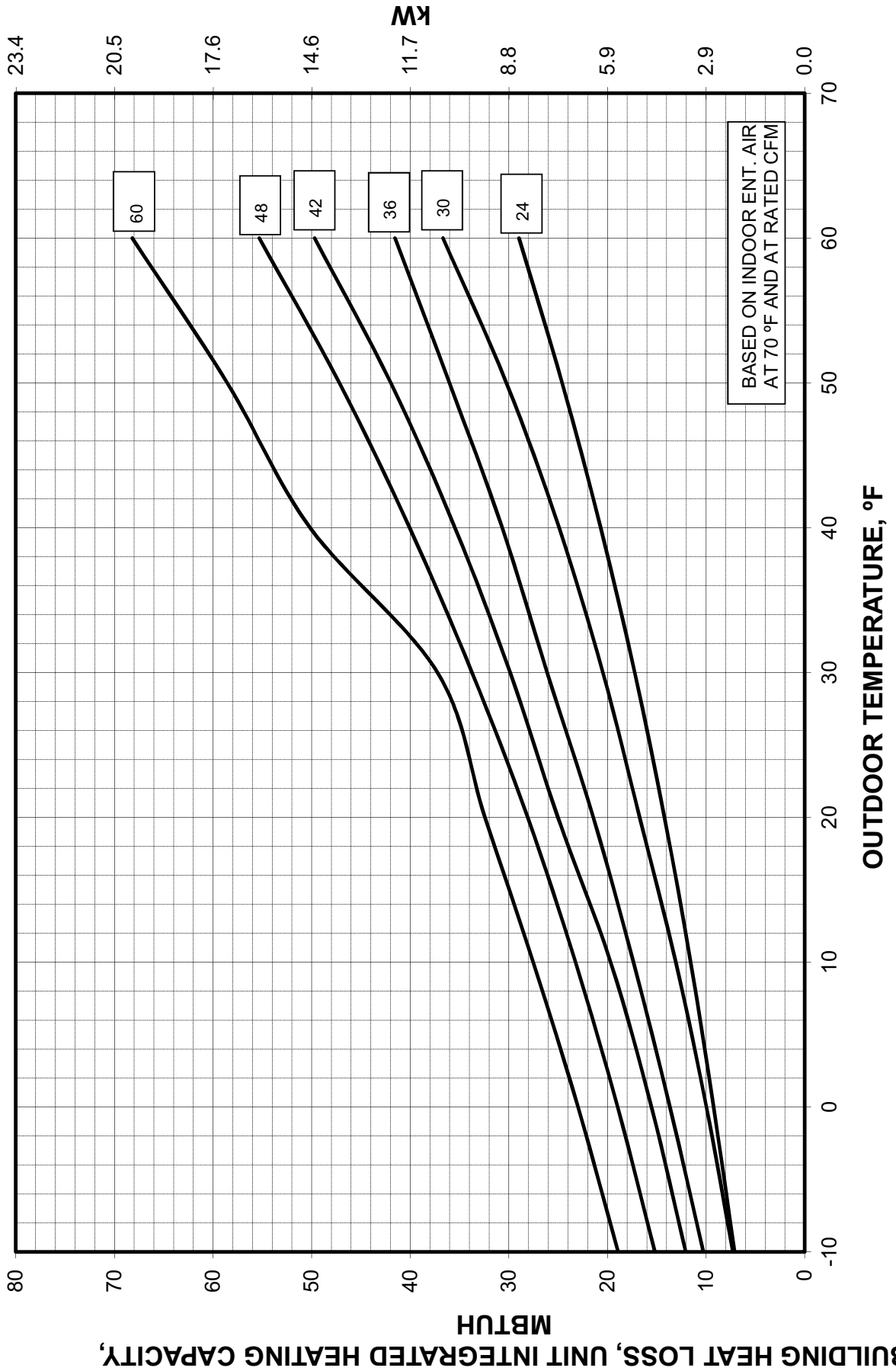

Performance Data

COOLING CAPACITY APPENDIX M TEST PROCEDURE  
024

EVAPORATOR AIR		CONDENSER ENTERING AIR TEMPERATURES °F (°C)																	
		75 (23.9)			85 (29.4)			95 (35)			105 (40.6)			115 (46.1)			125 (51.7)		
		CFM	EWB	Capacity MBtuh		Total Sys	Capacity MBtuh		Total Sys	Capacity MBtuh		Total Sys	Capacity MBtuh		Total Sys	Capacity MBtuh		Total Sys	Capacity MBtuh
Total	Sens†			KW*	Total	Sens†	KW*	Total	Sens†	KW*	Total	Sens†	KW*	Total	Sens†	KW*	Total	Sens†	KW*
700	57 (13.9)	21.71	21.71	1.70	20.80	20.80	1.89	19.82	19.82	2.10	18.69	18.69	2.34	16.95	16.95	2.59	15.34	15.34	2.89
	62 (16.7)	22.45	21.28	1.70	21.29	20.71	1.89	20.07	20.10	2.11	18.72	18.72	2.35	16.98	16.98	2.59	15.37	15.37	2.89
	63‡ (17.2)	22.88	17.30	1.70	21.68	16.74	1.90	20.42	16.16	2.11	18.97	15.50	2.35	16.64	14.46	2.59	14.52	13.52	2.87
	67 (19.4)	24.94	18.11	1.71	23.63	17.55	1.91	22.21	16.92	2.13	20.73	16.29	2.38	19.04	15.59	2.65	16.49	14.54	2.91
800	71 (21.7)	27.03	15.42	1.71	25.77	14.93	1.91	24.41	14.40	2.13	22.91	13.81	2.38	21.15	13.13	2.66	18.82	12.24	2.98
	57 (13.9)	22.74	22.74	1.73	21.75	21.75	1.92	20.72	20.72	2.14	19.55	19.55	2.38	17.91	17.91	2.64	16.16	16.16	2.93
	62 (16.7)	23.07	22.93	1.73	21.89	22.30	1.92	20.75	20.75	2.14	19.58	19.58	2.38	17.95	17.95	2.64	16.20	16.20	2.93
	63‡ (17.2)	23.42	18.45	1.73	22.16	17.87	1.92	20.85	17.28	2.14	19.37	16.62	2.38	17.10	15.61	2.62	14.89	14.62	2.91
900	67 (19.4)	25.53	19.32	1.73	24.20	18.77	1.93	22.80	18.20	2.15	21.26	17.56	2.40	19.42	16.78	2.68	16.92	15.76	2.95
	71 (21.7)	27.54	16.19	1.74	26.27	15.73	1.94	24.86	15.17	2.16	23.33	14.61	2.41	21.57	13.96	2.69	19.28	13.11	3.00
	57 (13.9)	23.61	23.61	1.76	22.57	22.57	1.95	21.46	21.46	2.17	20.27	20.27	2.42	18.87	18.87	2.70	16.88	16.88	2.97
	62 (16.7)	24.03	23.77	1.76	22.61	22.61	1.95	21.49	21.49	2.17	20.30	20.30	2.42	18.90	18.90	2.70	16.91	16.91	2.97
900	63‡ (17.2)	23.86	19.55	1.76	22.55	18.96	1.95	21.17	18.34	2.17	19.69	17.69	2.41	17.50	16.71	2.65	15.26	15.63	2.94
	67 (19.4)	25.96	20.45	1.76	24.63	19.92	1.95	23.21	19.36	2.17	21.66	18.73	2.42	19.73	17.93	2.71	17.30	16.91	2.98
	71 (21.7)	27.91	16.92	1.77	26.61	16.44	1.96	25.18	15.91	2.18	23.63	15.33	2.43	21.89	14.72	2.71	19.55	13.91	3.02

See page 17 for notes.

HEATING CAPACITY APPENDIX M TEST PROCEDURE  
024

INDOOR AIR		OUTDOOR COIL ENTERING AIR TEMPERATURES °F (°C)																							
		-10 (-23.3)			0 (-17.8)			10 (-12.2)			20 (-6.7)			30 (-1.1)			40 (4.4)			50 (10)			60 (15.6)		
		EDB	CFM	Capacity MBtuh		Total Sys	Capacity MBtuh		Total Sys	Capacity MBtuh		Total Sys	Capacity MBtuh		Total Sys	Capacity MBtuh		Total Sys	Capacity MBtuh		Total Sys	Capacity MBtuh		Total Sys	
Total	Integ			KW*	Total	Integ	KW*	Total	Integ	KW*	Total	Integ	KW*	Total	Integ	KW*	Total	Integ	KW*	Total	Integ	KW*			
65 (18.3)	700	7.39	6.80	1.63	9.23	8.49	1.66	11.15	10.23	1.71	13.21	11.99	1.76	17.82	15.61	1.92	20.63	20.63	1.97	23.71	23.71	2.04	27.03	27.03	2.11
	800	7.58	6.97	1.63	9.27	8.52	1.67	11.18	10.26	1.70	13.26	12.02	1.75	18.23	15.97	1.89	20.69	20.69	1.94	23.80	23.80	1.99	27.19	27.19	2.05
	900	7.47	6.86	1.65	9.49	8.73	1.67	11.22	10.30	1.70	13.28	12.04	1.73	17.91	15.69	1.88	21.18	21.18	1.91	23.89	23.89	1.96	27.31	27.31	2.00
70 (21.1)	700	7.31	6.72	1.71	9.13	8.40	1.75	11.04	10.13	1.79	13.09	11.87	1.84	17.63	15.45	2.01	20.40	20.40	2.07	23.44	23.44	2.14	26.71	26.71	2.21
	800	7.34	6.75	1.71	9.16	8.43	1.74	11.06	10.15	1.78	13.11	11.89	1.84	17.67	15.48	1.98	20.46	20.46	2.03	23.52	23.52	2.09	26.85	26.85	2.15
	900	7.38	6.78	1.72	9.19	8.45	1.76	11.09	10.17	1.78	13.14	11.92	1.82	17.71	15.52	1.97	20.51	20.51	2.01	23.60	23.60	2.05	26.97	26.97	2.10
75 (23.9)	700	7.27	6.69	1.79	9.17	8.43	1.83	10.93	10.03	1.88	12.97	11.76	1.94	17.52	15.35	2.11	20.44	20.44	2.17	23.16	23.16	2.24	26.37	26.37	2.32
	800	7.28	6.69	1.79	9.07	8.35	1.83	10.96	10.06	1.87	12.98	11.78	1.92	17.49	15.32	2.08	20.23	20.23	2.13	23.24	23.24	2.19	26.50	26.50	2.25
	900	7.32	6.73	1.79	9.10	8.37	1.84	10.98	10.07	1.87	13.00	11.79	1.91	17.56	15.38	2.06	20.28	20.28	2.10	23.31	23.31	2.15	26.61	26.61	2.20

See page 17 for notes.

Manufacturer reserves the right to change, at any time, specifications and designs without notice and without obligations.

Performance Data (cont)

COOLING CAPACITY APPENDIX M TEST PROCEDURE

030

EVAPORATOR AIR		CONDENSER ENTERING AIR TEMPERATURES °F (°C)																	
		75 (23.9)			85 (29.4)			95 (35)			105 (40.6)			115 (46.1)			125 (51.7)		
CFM	EWB	Capacity MBtuh		Total Sys	Capacity MBtuh		Total Sys	Capacity MBtuh		Total Sys	Capacity MBtuh		Total Sys	Capacity MBtuh		Total Sys	Capacity MBtuh		Total Sys
		Total	Sens†	KW*	Total	Sens†	KW*	Total	Sens†	KW*	Total	Sens†	KW*	Total	Sens†	KW*	Total	Sens†	KW*
875	57 (13.9)	28.37	28.37	2.14	27.19	27.19	2.38	25.92	25.92	2.65	24.47	24.47	2.95	22.21	22.21	3.26	20.13	20.13	3.64
	62 (16.7)	29.34	27.27	2.15	27.83	26.54	2.39	26.26	25.77	2.66	24.51	24.51	2.96	22.26	22.26	3.27	20.18	20.18	3.64
	63(17.2)‡	29.91	22.20	2.16	28.34	21.48	2.39	26.72	20.75	2.66	24.84	19.92	2.96	21.84	18.61	3.25	19.08	17.42	3.61
	67 (19.4)	32.52	23.20	2.17	30.82	22.48	2.41	29.06	21.74	2.69	27.15	20.93	3.00	24.90	20.02	3.35	21.62	18.71	3.68
	71 (21.7)	35.27	19.81	2.18	33.60	19.16	2.42	31.80	18.47	2.70	29.88	17.73	3.01	27.64	16.89	3.37	24.60	15.75	3.77
1000	57 (13.9)	29.77	29.77	2.18	28.49	28.49	2.42	27.13	27.13	2.69	25.64	25.64	3.00	23.54	23.54	3.32	21.26	21.26	3.69
	62 (16.7)	30.18	29.46	2.18	28.64	28.66	2.42	27.17	27.17	2.69	25.68	25.68	3.00	23.59	23.59	3.32	21.30	21.30	3.69
	63 (17.2)‡	30.65	23.73	2.18	29.01	23.00	2.42	27.28	22.24	2.69	25.40	21.41	2.99	22.47	20.15	3.29	19.60	18.90	3.64
	67 (19.4)	33.34	24.85	2.19	31.61	24.13	2.44	29.80	23.40	2.71	27.87	22.62	3.02	25.43	21.62	3.38	22.21	20.33	3.72
	71 (21.7)	35.97	20.90	2.21	34.27	20.23	2.45	32.41	19.55	2.72	30.43	18.83	3.04	28.20	18.01	3.39	25.14	16.91	3.79
1125	57 (13.9)	30.97	30.97	2.21	29.60	29.60	2.45	28.15	28.15	2.72	26.61	26.61	3.04	24.79	24.79	3.39	22.23	22.23	3.74
	62 (16.7)	31.00	31.00	2.21	29.64	29.64	2.45	28.19	28.19	2.72	26.65	26.65	3.04	24.83	24.83	3.39	22.27	22.27	3.74
	63 (17.2)‡	31.22	25.19	2.21	29.53	24.45	2.45	27.75	23.67	2.72	25.83	22.84	3.02	23.02	21.62	3.33	20.09	20.00	3.68
	67 (19.4)	33.94	26.40	2.21	32.20	25.68	2.46	30.36	24.97	2.73	28.39	24.18	3.04	25.96	23.20	3.40	22.75	21.88	3.76
	71 (21.7)	36.47	21.90	2.23	34.73	21.28	2.47	32.85	20.56	2.75	30.83	19.82	3.06	28.59	19.03	3.41	25.56	18.01	3.81

See page 17 for notes.

HEATING CAPACITY APPENDIX M TEST PROCEDURE

030

INDOOR AIR		OUTDOOR COIL ENTERING AIR TEMPERATURES °F (°C)																							
		-10 (-23.3)			0 (-17.8)			10 (-12.2)			20 (-6.7)			30 (-1.1)			40 (4.4)			50 (10)			60 (15.6)		
EDB	CFM	Capacity MBtuh		Total Sys	Capacity MBtuh		Total Sys	Capacity MBtuh		Total Sys	Capacity MBtuh		Total Sys	Capacity MBtuh		Total Sys	Capacity MBtuh		Total Sys	Capacity MBtuh		Total Sys	Capacity MBtuh		Total Sys
		Total	Integ	KW*	Total	Integ	KW*	Total	Integ	KW*	Total	Integ	KW*	Total	Integ	KW*	Total	Integ	KW*	Total	Integ	KW*	Total	Integ	KW*
65 (18.3)	875	8.99	8.27	1.88	11.81	10.87	1.95	14.86	13.64	2.02	18.15	16.46	2.09	22.80	19.97	2.21	25.78	25.78	2.27	29.91	29.91	2.37	34.83	34.83	2.49
	1000	9.14	8.41	1.88	11.99	11.03	1.95	15.06	13.82	2.01	18.41	16.69	2.08	22.41	19.63	2.16	26.05	26.05	2.23	30.28	30.28	2.31	35.33	35.33	2.42
	1125	9.26	8.52	1.89	12.14	11.17	1.95	15.23	13.98	2.01	18.62	16.88	2.07	22.59	19.80	2.14	26.27	26.27	2.20	30.58	30.58	2.27	35.74	35.74	2.37
70 (21.1)	875	8.49	7.81	1.96	11.34	10.43	2.04	14.41	13.22	2.11	17.73	16.08	2.19	21.86	19.16	2.30	25.42	25.42	2.38	29.49	29.49	2.48	34.31	34.31	2.60
	1000	8.63	7.94	1.96	11.51	10.58	2.04	14.60	13.39	2.09	17.95	16.28	2.17	22.74	19.92	2.28	25.70	25.70	2.34	29.84	29.84	2.42	34.79	34.79	2.53
	1125	8.75	8.05	1.98	11.65	10.72	2.04	14.77	13.56	2.10	18.16	16.47	2.16	22.28	19.52	2.25	25.91	25.91	2.31	30.13	30.13	2.38	35.21	35.21	2.48
75 (23.9)	875	7.98	7.34	2.04	10.85	9.99	2.12	13.95	12.80	2.21	17.27	15.67	2.29	20.95	18.36	2.38	25.09	25.09	2.49	29.07	29.07	2.59	33.79	33.79	2.72
	1000	8.11	7.46	2.05	11.02	10.14	2.12	14.14	12.98	2.20	17.51	15.88	2.27	21.33	18.69	2.36	25.34	25.34	2.45	29.42	29.42	2.53	34.26	34.26	2.64
	1125	8.22	7.56	2.06	11.15	10.26	2.12	14.29	13.13	2.20	17.70	16.06	2.25	21.93	19.22	2.35	25.56	25.56	2.42	29.70	29.70	2.49	34.65	34.65	2.59

See page 17 for notes.

Manufacturer reserves the right to change, at any time, specifications and designs without notice and without obligations.

Performance Data (cont)

COOLING CAPACITY APPENDIX M TEST PROCEDURE

036

EVAPORATOR AIR		CONDENSER ENTERING AIR TEMPERATURES °F (°C)																	
		75 (23.9)			85 (29.4)			95 (35)			105 (40.6)			115 (46.1)			125 (51.7)		
		Capacity MBtuh	Total Sys KW*	Sens†	Capacity MBtuh	Total Sys KW*	Sens†	Capacity MBtuh	Total Sys KW*	Sens†	Capacity MBtuh	Total Sys KW*	Sens†	Capacity MBtuh	Total Sys KW*	Sens†	Capacity MBtuh	Total Sys KW*	Sens†
CFM	EWB																		
1050	57 (13.9)	34.99	34.99	2.58	33.37	33.37	2.86	31.59	31.59	3.16	29.63	29.63	3.52	26.83	26.83	3.88	24.10	24.10	4.33
	62 (16.7)	35.96	33.45	2.59	33.90	32.47	2.87	31.78	31.39	3.17	29.68	29.68	3.52	26.89	26.89	3.89	24.15	24.15	4.33
	63 (17.2)‡	36.61	27.12	2.60	34.46	26.16	2.87	32.21	25.17	3.17	29.72	24.09	3.51	25.98	22.48	3.85	22.48	20.99	4.27
	67 (19.4)	39.75	28.34	2.64	37.47	27.40	2.92	35.05	26.41	3.22	32.40	25.34	3.57	29.41	24.11	3.98	25.35	22.52	4.37
	71 (21.7)	42.91	24.00	2.68	40.59	23.15	2.96	38.08	22.19	3.26	35.43	21.20	3.61	32.48	20.13	4.01	28.61	18.72	4.50
1200	57 (13.9)	36.64	36.64	2.63	34.86	34.86	2.91	32.96	32.96	3.22	30.92	30.92	3.58	28.47	28.47	3.98	25.33	25.33	4.40
	62 (16.7)	36.95	36.10	2.64	34.92	34.92	2.91	33.00	33.00	3.22	30.97	30.97	3.58	28.58	28.58	3.98	25.38	25.38	4.40
	63 (17.2)‡	37.42	28.98	2.64	35.19	28.00	2.92	32.83	26.98	3.22	30.30	25.89	3.56	26.66	24.34	3.91	23.08	22.73	4.32
	67 (19.4)	40.62	30.31	2.68	38.28	29.34	2.95	35.80	28.40	3.25	33.11	27.32	3.61	29.95	26.05	4.02	25.97	24.46	4.42
	71 (21.7)	43.65	25.31	2.73	41.28	24.43	2.99	38.69	23.51	3.30	35.99	22.50	3.64	33.04	21.46	4.05	29.17	20.13	4.53
1350	57 (13.9)	38.07	38.07	2.68	36.18	36.18	2.96	34.19	34.19	3.27	32.06	32.06	3.63	29.55	29.55	4.05	26.37	26.37	4.47
	62 (16.7)	38.12	38.12	2.68	36.26	36.26	2.96	34.24	34.24	3.27	32.11	32.11	3.63	29.60	29.60	4.05	26.42	26.42	4.47
	63 (17.2)‡	38.14	30.82	2.68	35.76	29.77	2.96	33.32	28.72	3.26	30.75	27.62	3.60	27.27	26.09	3.96	23.41	23.41	4.36
	67 (19.4)	41.26	32.17	2.71	38.89	31.26	2.99	36.35	30.28	3.29	33.63	29.20	3.64	30.50	27.97	4.05	26.54	26.23	4.48
	71 (21.7)	44.17	26.53	2.76	41.76	25.66	3.03	39.14	24.71	3.33	36.36	23.74	3.68	33.42	22.71	4.08	29.62	21.47	4.56

See page 17 for notes.

HEATING CAPACITY APPENDIX M TEST PROCEDURE

036

INDOOR AIR		OUTDOOR COIL ENTERING AIR TEMPERATURES °F (°C)																															
		-10 (-23.3)				0 (-17.8)				10 (-12.2)				20 (-6.7)				30 (-1.1)				40 (4.4)				50 (10)				60 (15.6)			
		Capacity MBtuh	Total Sys KW*	Integ	Sens†	Capacity MBtuh	Total Sys KW*	Integ	Sens†	Capacity MBtuh	Total Sys KW*	Integ	Sens†	Capacity MBtuh	Total Sys KW*	Integ	Sens†	Capacity MBtuh	Total Sys KW*	Integ	Sens†	Capacity MBtuh	Total Sys KW*	Integ	Sens†								
EDB	CFM																									Total	Sens†	Total	Sens†	Total	Sens†	Total	Sens†
65 (18.3)	1050	9.95	9.16	2.03	13.04	12.00	2.15	16.45	15.10	2.24	20.79	18.85	2.35	24.66	21.60	2.44	28.77	28.77	2.53	33.51	33.51	2.64	39.12	39.12	2.77								
	1200	10.10	9.30	2.04	13.24	12.18	2.15	16.67	15.30	2.24	21.07	19.11	2.33	24.86	21.78	2.41	29.07	29.07	2.49	33.93	33.93	2.59	39.50	39.50	2.69								
	1350	10.25	9.44	2.05	13.37	12.29	2.15	16.82	15.44	2.24	20.63	18.71	2.31	25.02	21.92	2.39	29.30	29.30	2.46	34.26	34.26	2.55	39.57	39.57	2.63								
70 (21.1)	1050	9.48	8.72	2.13	12.62	11.61	2.25	16.05	14.73	2.35	20.24	18.36	2.46	24.36	21.34	2.56	28.39	28.39	2.65	33.01	33.01	2.76	38.49	38.49	2.90								
	1200	9.64	8.87	2.14	12.79	11.77	2.26	16.25	14.91	2.35	20.01	18.15	2.43	24.59	21.54	2.53	28.68	28.68	2.61	33.42	33.42	2.71	38.95	38.95	2.81								
	1350	9.77	8.99	2.16	12.94	11.90	2.26	16.42	15.07	2.35	20.68	18.76	2.44	24.76	21.70	2.52	28.93	28.93	2.58	33.76	33.76	2.68	39.10	39.10	2.76								
75 (23.9)	1050	8.94	8.23	2.22	12.12	11.16	2.35	15.59	14.31	2.46	19.28	17.48	2.56	24.00	21.03	2.69	27.97	27.97	2.78	32.49	32.49	2.89	37.85	37.85	3.03								
	1200	9.10	8.37	2.24	12.31	11.33	2.36	15.80	14.50	2.46	19.92	18.07	2.56	24.25	21.25	2.66	28.29	28.29	2.74	32.90	32.90	2.83	38.36	38.36	2.94								
	1350	9.24	8.50	2.25	12.46	11.46	2.37	15.98	14.66	2.46	19.77	17.93	2.54	24.45	21.43	2.64	28.53	28.53	2.71	33.24	33.24	2.80	38.58	38.58	2.89								

See page 17 for notes.

Manufacturer reserves the right to change, at any time, specifications and designs without notice and without obligations.

**Performance Data (cont)**  
**COOLING CAPACITY APPENDIX M TEST PROCEDURE**

**042**

EVAPORATOR AIR		CONDENSER ENTERING AIR TEMPERATURES °F (°C)																	
		75 (23.9)			85 (29.4)			95 (35)			105 (40.6)			115 (46.1)			125 (51.7)		
		Capacity MBtuh	Total Sys KW*	Total	Capacity MBtuh	Total Sys KW*	Total	Capacity MBtuh	Total Sys KW*	Total	Capacity MBtuh	Total Sys KW*	Total	Capacity MBtuh	Total Sys KW*	Total	Capacity MBtuh	Total Sys KW*	Total
Sens†	Sens†																		
CFM	EWB	Total	Sens†	Total	Sens†	Total	Sens†	Total	Sens†	Total	Sens†	Total	Sens†	Total	Sens†	Total	Sens†	Total	
1225	57 (13.9)	41.31	41.31	3.06	39.48	39.48	3.39	36.60	36.60	3.72	33.50	33.50	4.08	30.34	30.34	4.47	26.95	26.95	4.85
	62 (16.7)	42.27	38.37	3.07	40.03	37.31	3.40	36.65	36.65	3.72	33.56	33.56	4.08	30.40	30.40	4.47	26.99	26.99	4.85
	63 (17.2)†	42.93	31.05	3.07	40.57	30.03	3.40	37.08	28.54	3.73	33.01	26.83	4.07	28.99	25.17	4.45	24.77	23.37	4.83
	67 (19.4)	46.49	32.40	3.10	44.05	31.44	3.43	41.20	30.29	3.78	36.60	28.47	4.13	32.12	26.75	4.49	27.69	25.05	4.86
	71 (21.7)	50.03	27.34	3.13	47.42	26.37	3.45	44.58	25.32	3.80	40.54	23.93	4.17	35.66	22.19	4.53	30.73	20.50	4.88
1400	57 (13.9)	43.10	43.10	3.11	41.12	41.12	3.45	38.86	38.86	3.81	35.14	35.14	4.14	31.67	31.67	4.51	28.09	28.09	4.89
	62 (16.7)	43.39	41.29	3.12	41.18	41.18	3.45	38.92	38.92	3.81	35.20	35.20	4.14	31.72	31.72	4.51	28.14	28.14	4.89
	63 (17.2)†	43.86	33.16	3.12	41.38	32.10	3.45	38.56	30.92	3.80	33.71	28.90	4.12	29.62	27.16	4.49	25.59	25.59	4.87
	67 (19.4)	47.42	34.61	3.14	44.89	33.65	3.47	42.00	32.50	3.82	37.48	30.76	4.18	32.75	28.93	4.53	28.28	27.05	4.89
	71 (21.7)	50.83	28.78	3.18	48.13	27.82	3.50	45.19	26.73	3.84	41.31	25.49	4.20	36.27	23.75	4.57	31.18	22.03	4.92
1575	57 (13.9)	44.72	44.72	3.16	42.67	42.67	3.49	40.32	40.32	3.84	36.56	36.56	4.20	32.80	32.80	4.56	29.04	29.04	4.93
	62 (16.7)	44.78	44.78	3.16	42.74	42.74	3.49	40.37	40.37	3.85	36.61	36.61	4.20	32.85	32.85	4.56	29.08	29.08	4.93
	63 (17.2)†	44.63	35.22	3.15	42.12	34.17	3.48	39.16	32.90	3.84	34.36	30.87	4.16	30.19	28.94	4.53	26.44	26.44	4.91
	67 (19.4)	48.11	36.68	3.18	45.49	35.69	3.50	42.59	34.58	3.85	38.11	32.89	4.22	33.34	30.98	4.57	29.14	29.14	4.94
	71 (21.7)	51.41	30.12	3.22	48.64	29.14	3.53	45.62	28.06	3.88	41.88	26.95	4.24	36.71	25.24	4.61	31.54	23.50	4.95

See page 17 for notes.

**HEATING CAPACITY APPENDIX M TEST PROCEDURE**

**042**

INDOOR AIR		OUTDOOR COIL ENTERING AIR TEMPERATURES °F (°C)																							
		-10 (-23.3)			0 (-17.8)			10 (-12.2)			20 (-6.7)			30 (-1.1)			40 (4.4)			50 (10)			60 (15.6)		
		Capacity MBtuh	Total Sys KW*	Total	Capacity MBtuh	Total Sys KW*	Total	Capacity MBtuh	Total Sys KW*	Total	Capacity MBtuh	Total Sys KW*	Total	Capacity MBtuh	Total Sys KW*	Total	Capacity MBtuh	Total Sys KW*	Total	Capacity MBtuh	Total Sys KW*	Total			
Integ	Integ																						Integ	Integ	Integ
EDB	CFM	Total	Integ	Total	Integ	Total	Integ	Total	Integ	Total	Integ	Total	Integ	Total	Integ	Total	Integ	Total	Integ	Total	Integ	Total	Integ		
65 (18.3)	1225	13.51	12.42	2.82	16.86	15.51	2.84	20.86	19.15	2.89	26.58	24.10	2.99	30.74	26.94	3.06	35.94	35.94	3.16	41.91	41.91	3.30	48.80	48.80	3.44
	1400	13.71	12.61	2.84	17.07	15.70	2.86	21.08	19.35	2.89	26.80	24.30	2.97	30.96	27.13	3.02	36.26	36.26	3.11	42.37	42.37	3.23	49.13	49.13	3.35
	1575	13.88	12.77	2.86	17.25	15.87	2.87	21.28	19.53	2.89	26.42	23.96	2.96	31.17	27.31	3.01	36.52	36.52	3.08	42.73	42.73	3.20	49.16	49.16	3.29
70 (21.1)	1225	12.84	11.81	2.90	16.31	15.01	2.94	20.38	18.71	3.00	25.06	22.72	3.09	30.42	26.66	3.21	35.52	35.52	3.31	41.34	41.34	3.45	48.09	48.09	3.61
	1400	13.04	11.99	2.92	16.52	15.20	2.95	20.61	18.92	3.00	25.29	22.94	3.07	30.67	26.87	3.17	35.83	35.83	3.26	41.79	41.79	3.39	48.42	48.42	3.52
	1575	13.21	12.15	2.94	16.70	15.37	2.97	20.81	19.10	3.01	25.63	23.24	3.07	30.87	27.05	3.15	36.10	36.10	3.23	42.16	42.16	3.35	48.66	48.66	3.44
75 (23.9)	1225	12.15	11.18	2.98	15.72	14.47	3.05	19.88	18.24	3.13	24.54	22.25	3.23	30.11	26.38	3.36	35.08	35.08	3.47	40.77	40.77	3.61	47.36	47.36	3.78
	1400	12.34	11.36	3.00	15.93	14.66	3.06	20.11	18.45	3.13	24.79	22.49	3.21	30.34	26.58	3.33	35.40	35.40	3.42	41.21	41.21	3.55	47.87	47.87	3.67
	1575	12.51	11.51	3.02	16.11	14.83	3.07	20.31	18.64	3.13	25.02	22.69	3.20	30.53	26.75	3.30	35.66	35.66	3.39	41.58	41.58	3.50	48.08	48.08	3.61

See page 17 for notes.

Manufacturer reserves the right to change, at any time, specifications and designs without notice and without obligations.

Performance Data (cont)

COOLING CAPACITY APPENDIX M TEST PROCEDURE

048

EVAPORATOR AIR		CONDENSER ENTERING AIR TEMPERATURES °F (°C)																	
		75 (23.9)			85 (29.4)			95 (35)			105 (40.6)			115 (46.1)			125 (51.7)		
		CFM	EWB	Capacity MBtuh		Total Sys KW*	Capacity MBtuh		Total Sys KW*	Capacity MBtuh		Total Sys KW*	Capacity MBtuh		Total Sys KW*	Capacity MBtuh		Total Sys KW*	Capacity MBtuh
Total	Sens†			Total	Sens†		Total	Sens†		Total	Sens†		Total	Sens†		Total	Sens†		
1400	57 (13.9)	46.08	46.08	3.33	44.18	44.18	3.71	42.10	42.10	4.13	39.77	39.77	4.60	37.25	37.25	5.12	34.46	34.46	5.69
	62 (16.7)	47.27	42.78	3.34	44.93	41.66	3.71	42.44	40.44	4.13	39.83	39.83	4.60	37.30	37.30	5.12	34.51	34.51	5.69
	63 (17.2)‡	47.94	34.65	3.35	45.52	33.58	3.72	42.91	32.45	4.14	40.05	31.23	4.60	37.02	29.95	5.12	33.74	28.57	5.68
	67 (19.4)	51.35	35.90	3.38	48.70	34.82	3.75	45.86	33.68	4.17	42.79	32.46	4.64	39.53	31.18	5.16	36.02	29.81	5.72
1600	57 (13.9)	47.92	47.92	3.39	45.84	45.84	3.77	43.59	43.59	4.19	41.09	41.09	4.66	38.41	38.41	5.18	35.46	35.46	5.76
	62 (16.7)	48.34	45.89	3.40	45.98	45.66	3.77	43.65	43.65	4.19	41.14	41.14	4.66	38.46	38.46	5.18	35.50	35.50	5.76
	63 (17.2)‡	48.83	36.88	3.40	46.28	35.77	3.77	43.56	34.62	4.19	40.60	33.36	4.65	37.48	32.05	5.17	34.13	30.62	5.73
	67 (19.4)	52.22	38.27	3.43	49.46	37.17	3.81	46.50	36.00	4.23	43.33	34.76	4.69	39.98	33.45	5.21	36.39	32.04	5.77
1800	57 (13.9)	49.39	49.39	3.45	47.20	47.20	3.83	44.80	44.80	4.25	42.17	42.17	4.72	39.34	39.34	5.24	36.25	36.25	5.81
	62 (16.7)	50.04	46.60	3.46	47.25	47.25	3.83	44.85	44.85	4.25	42.21	42.21	4.72	39.38	39.38	5.24	36.28	36.28	5.81
	63 (17.2)‡	49.50	38.99	3.45	46.86	37.86	3.82	44.06	36.68	4.24	41.03	35.40	4.71	37.85	34.03	5.22	34.45	32.51	5.78
	67 (19.4)	52.87	40.55	3.48	50.03	39.42	3.86	46.99	38.23	4.28	43.75	36.96	4.74	40.33	35.60	5.26	36.69	34.11	5.82
	71 (21.7)	56.55	33.46	3.52	53.46	32.35	3.89	50.17	31.19	4.31	46.65	29.96	4.78	42.94	28.68	5.29	38.98	27.32	5.86

See page 17 for notes.

HEATING CAPACITY APPENDIX M TEST PROCEDURE

048

INDOOR AIR		OUTDOOR COIL ENTERING AIR TEMPERATURES °F (°C)																							
		-10 (-23.3)			0 (-17.8)			10 (-12.2)			20 (-6.7)			30 (-1.1)			40 (4.4)			50 (10)			60 (15.6)		
		EDB	CFM	Capacity MBtuh		Total Sys KW*	Capacity MBtuh		Total Sys KW*	Capacity MBtuh		Total Sys KW*	Capacity MBtuh		Total Sys KW*	Capacity MBtuh		Total Sys KW*	Capacity MBtuh		Total Sys KW*	Capacity MBtuh		Total Sys KW*	
Total	Integ			Total	Integ		Total	Integ		Total	Integ		Total	Integ		Total	Integ		Total	Integ		Total	Integ		
65 (18.3)	1400	18.72	17.23	3.10	22.32	20.53	3.19	26.25	24.09	3.28	30.68	27.83	3.38	35.71	31.29	3.48	41.16	41.16	3.58	47.20	47.20	3.70	53.97	53.97	3.84
	1600	18.81	17.31	3.11	22.39	20.60	3.19	26.30	24.14	3.27	30.72	27.86	3.35	35.73	31.31	3.43	41.18	41.18	3.52	47.23	47.23	3.62	54.07	54.07	3.73
	1800	18.91	17.40	3.12	22.47	20.68	3.20	26.37	24.20	3.27	30.77	27.90	3.34	35.77	31.34	3.41	41.22	41.22	3.49	47.29	47.29	3.57	54.18	54.18	3.66
70 (21.1)	1400	18.59	17.10	3.25	22.17	20.40	3.35	26.25	24.10	3.44	30.46	27.63	3.54	35.43	31.04	3.65	40.81	40.81	3.76	46.76	46.76	3.89	53.45	53.45	4.03
	1600	18.68	17.18	3.26	22.24	20.46	3.35	26.31	24.14	3.43	30.49	27.65	3.52	35.44	31.05	3.60	40.82	40.82	3.70	46.79	46.79	3.80	53.53	53.53	3.91
	1800	18.78	17.27	3.27	22.32	20.54	3.35	26.20	24.05	3.42	30.54	27.70	3.50	35.48	31.09	3.58	40.85	40.85	3.66	46.84	46.84	3.74	53.63	53.63	3.84
75 (23.9)	1400	18.45	16.98	3.41	22.03	20.27	3.51	26.08	23.93	3.61	30.24	27.43	3.72	35.15	30.80	3.83	40.45	40.45	3.95	46.33	46.33	4.08	52.92	52.92	4.22
	1600	18.55	17.06	3.42	22.10	20.33	3.51	26.13	23.98	3.60	30.27	27.45	3.69	35.16	30.80	3.78	40.45	40.45	3.88	46.35	46.35	3.99	52.99	52.99	4.11
	1800	18.64	17.15	3.43	22.18	20.41	3.52	26.20	24.04	3.59	30.32	27.50	3.68	35.19	30.84	3.76	40.49	40.49	3.84	46.39	46.39	3.93	53.07	53.07	4.03

See page 17 for notes.

Manufacturer reserves the right to change, at any time, specifications and designs without notice and without obligations.

Performance Data (cont)

COOLING CAPACITY APPENDIX M TEST PROCEDURE

060

EVAPORATOR AIR		CONDENSER ENTERING AIR TEMPERATURES °F (°C)																	
CFM	EWB	75 (23.9)			85 (29.4)			95 (35)			105 (40.6)			115 (46.1)			125 (51.7)		
		Capacity MBtuh		Total Sys KW*	Capacity MBtuh		Total Sys KW*	Capacity MBtuh		Total Sys KW*	Capacity MBtuh		Total Sys KW*	Capacity MBtuh		Total Sys KW*	Capacity MBtuh		Total Sys KW*
		Total	Sens†		Total	Sens†		Total	Sens†		Total	Sens†		Total	Sens†		Total	Sens†	
1500	57 (13.9)	53.09	53.09	3.96	51.01	51.01	4.39	48.70	48.70	4.88	46.15	46.15	5.44	43.31	43.31	6.08	40.15	40.15	6.77
	62 (16.7)	55.26	49.76	3.97	52.61	48.49	4.41	49.74	47.11	4.90	46.64	45.58	5.45	43.38	43.38	6.08	40.20	40.20	6.77
	63 (17.2)‡	56.21	40.69	3.98	53.47	39.42	4.42	50.50	38.07	4.91	47.26	36.61	5.46	43.75	35.06	6.08	39.90	33.38	6.76
	67 (19.4)	60.31	42.11	4.01	57.34	40.83	4.45	54.11	39.47	4.95	50.62	38.02	5.51	46.85	36.47	6.13	42.75	34.81	6.82
1700	57 (13.9)	55.26	55.26	4.01	53.03	53.03	4.45	50.54	50.54	4.95	47.79	47.79	5.51	44.77	44.77	6.14	41.43	41.43	6.83
	62 (16.7)	56.51	53.27	4.02	53.78	51.92	4.46	50.84	50.40	4.95	47.86	47.86	5.51	44.83	44.83	6.14	41.48	41.48	6.83
	63 (17.2)‡	57.35	43.10	4.03	54.47	41.80	4.47	51.37	40.42	4.96	48.01	38.94	5.51	44.37	37.35	6.13	40.42	35.64	6.81
	67 (19.4)	61.48	44.70	4.06	58.35	43.39	4.50	55.00	42.00	5.00	51.38	40.52	5.56	47.49	38.95	6.19	43.28	37.26	6.87
1850	57 (13.9)	56.69	56.69	4.05	54.31	54.31	4.49	51.71	51.71	4.99	48.84	48.84	5.56	45.70	45.70	6.19	42.23	42.23	6.88
	62 (16.7)	57.36	55.76	4.06	54.59	54.26	4.50	51.78	51.78	4.99	48.90	48.90	5.56	45.76	45.76	6.19	42.28	42.28	6.88
	63 (17.2)‡	58.02	44.84	4.06	55.07	43.53	4.50	51.89	42.13	4.99	48.45	40.62	5.55	44.75	39.01	6.17	40.74	37.27	6.85
	67 (19.4)	62.18	46.57	4.09	58.97	45.24	4.54	55.53	43.84	5.04	51.84	42.34	5.60	47.87	40.75	6.22	43.59	39.02	6.90
	71 (21.7)	66.72	38.98	4.12	63.27	37.67	4.57	59.56	36.28	5.08	55.57	34.81	5.65	51.27	33.24	6.28	46.68	31.59	6.95

See page 17 for notes.

HEATING CAPACITY APPENDIX M TEST PROCEDURE

060

INDOOR AIR		OUTDOOR COIL ENTERING AIR TEMPERATURES °F (°C)																							
EDB	CFM	-10 (-23.3)			0 (-17.8)			10 (-12.2)			20 (-6.7)			30 (-1.1)			40 (4.4)			50 (10)			60 (15.6)		
		Capacity MBtuh		Total Sys KW*	Capacity MBtuh		Total Sys KW*	Capacity MBtuh		Total Sys KW*	Capacity MBtuh		Total Sys KW*	Capacity MBtuh		Total Sys KW*	Capacity MBtuh		Total Sys KW*	Capacity MBtuh		Total Sys KW*	Capacity MBtuh		Total Sys KW*
		Total	Integ		Total	Integ		Total	Integ		Total	Integ		Total	Integ		Total	Integ		Total	Integ		Total	Integ	
65 (18.3)	1500	20.73	19.07	3.58	25.95	23.89	3.73	30.36	27.87	3.89	37.32	33.85	4.07	43.56	38.17	4.23	50.51	50.51	4.42	58.51	58.51	4.65	68.04	68.04	4.95
	1700	21.04	19.35	3.60	26.22	24.14	3.74	30.73	28.21	3.88	37.64	34.14	4.04	43.95	38.51	4.18	51.02	51.02	4.34	59.17	59.17	4.55	68.94	68.94	4.82
	1850	21.24	19.55	3.62	26.44	24.31	3.74	30.97	28.43	3.88	37.88	34.35	4.02	44.22	38.74	4.15	51.34	51.34	4.31	59.57	59.57	4.50	69.47	69.47	4.75
70 (21.1)	1500	20.28	18.66	3.71	26.30	24.20	3.91	29.67	27.23	4.05	37.74	34.23	4.27	43.06	37.73	4.42	49.89	49.89	4.62	57.76	57.76	4.86	67.10	67.10	5.16
	1700	20.59	18.94	3.74	25.95	23.88	3.89	30.03	27.56	4.03	37.16	33.70	4.21	43.45	38.07	4.36	50.39	50.39	4.54	58.41	58.41	4.75	67.99	67.99	5.03
	1850	20.8	19.13	3.75	26.15	24.05	3.89	30.26	27.77	4.03	37.38	33.90	4.19	43.68	38.27	4.33	50.70	50.70	4.50	58.81	58.81	4.70	68.51	68.51	4.96
75 (23.9)	1500	19.80	18.22	3.86	24.53	22.57	4.01	28.94	26.57	4.21	35.16	31.89	4.39	42.60	37.33	4.62	49.28	49.28	4.83	57.02	57.02	5.08	66.19	66.19	5.39
	1700	20.11	18.51	3.88	24.89	22.90	4.02	29.30	26.90	4.20	35.60	32.28	4.35	42.96	37.64	4.56	49.76	49.76	4.74	57.65	57.65	4.97	67.06	67.06	5.25
	1850	20.31	18.70	3.90	25.18	23.17	4.03	29.52	27.1	4.20	35.95	32.60	4.34	43.20	37.85	4.53	50.07	50.07	4.70	58.05	58.05	4.91	67.58	67.58	5.18

See page 17 for notes.

Manufacturer reserves the right to change, at any time, specifications and designs without notice and without obligations.

**Performance Data (cont)**  
**COOLING CAPACITY APPENDIX M1 TEST PROCEDURE**  
**024**

EVAPORATOR AIR		CONDENSER ENTERING AIR TEMPERATURES °F (°C)																	
CFM	EWB	75 (23.9)			85 (29.4)			95 (35)			105 (40.6)			115 (46.1)			125 (51.7)		
		Capacity MBtuh		Total Sys KW*	Capacity MBtuh		Total Sys KW*	Capacity MBtuh		Total Sys KW*	Capacity MBtuh		Total Sys KW*	Capacity MBtuh		Total Sys KW*	Capacity MBtuh		Total Sys KW*
		Total	Sens†		Total	Sens†		Total	Sens†		Total	Sens†		Total	Sens†		Total	Sens†	
700	57 (13.9)	21.65	21.65	1.70	20.74	20.74	1.89	19.77	19.77	2.11	18.64	18.64	2.35	16.90	16.90	2.60	15.29	15.29	2.90
	62 (16.7)	22.38	21.26	1.71	21.24	20.69	1.90	20.02	20.08	2.11	18.67	18.67	2.35	16.93	16.93	2.60	15.33	15.33	2.90
	63 (17.2)‡	22.82	17.29	1.71	21.62	16.72	1.90	20.36	16.14	2.11	18.91	15.49	2.35	16.59	14.44	2.59	14.48	13.51	2.88
	67 (19.4)	24.89	18.10	1.71	23.62	17.55	1.91	22.27	16.97	2.13	20.75	16.31	2.38	18.98	15.57	2.65	16.44	14.53	2.92
	71 (21.7)	26.92	15.38	1.72	25.68	14.91	1.91	24.34	14.37	2.13	22.89	13.78	2.38	21.12	13.13	2.66	18.78	12.23	2.98
800	57 (13.9)	22.67	22.67	1.73	21.69	21.69	1.92	20.65	20.65	2.14	19.50	19.50	2.39	17.86	17.86	2.64	16.12	16.12	2.94
	62 (16.7)	23.00	22.91	1.73	21.83	22.28	1.93	20.68	20.68	2.14	19.53	19.53	2.39	17.90	17.90	2.64	16.15	16.15	2.94
	63 (17.2)‡	23.36	18.43	1.74	22.10	17.86	1.93	20.78	17.26	2.14	19.32	16.61	2.38	17.05	15.59	2.62	14.84	14.61	2.91
	67 (19.4)	25.46	19.28	1.73	24.17	18.76	1.93	22.80	18.20	2.15	21.27	17.56	2.40	19.37	16.77	2.68	16.87	15.74	2.95
	71 (21.7)	27.41	16.16	1.74	26.15	15.66	1.94	24.76	15.14	2.16	23.26	14.58	2.41	21.55	13.95	2.69	19.14	13.07	3.00
900	57 (13.9)	23.58	23.58	1.76	22.52	22.52	1.96	21.44	21.44	2.17	20.23	20.23	2.42	18.82	18.82	2.70	16.83	16.83	2.98
	62 (16.7)	23.64	23.51	1.76	22.57	22.57	1.96	21.45	21.45	2.17	20.26	20.26	2.42	18.85	18.85	2.70	16.86	16.86	2.98
	63 (17.2)‡	23.82	19.54	1.76	22.48	18.94	1.95	21.12	18.33	2.17	19.64	17.67	2.41	17.44	16.69	2.66	15.21	15.62	2.94
	67 (19.4)	25.88	20.38	1.76	24.58	19.89	1.95	23.19	19.34	2.17	21.66	18.72	2.42	19.73	17.93	2.71	17.25	16.90	2.99
	71 (21.7)	27.77	16.85	1.77	26.48	16.39	1.97	25.07	15.86	2.19	23.55	15.28	2.43	21.83	14.68	2.71	19.42	13.88	3.02

See page 22 for notes.

**HEATING CAPACITY APPENDIX M1 TEST PROCEDURE**  
**024**

INDOOR AIR		OUTDOOR COIL ENTERING AIR TEMPERATURES °F (°C)																							
EDB	CFM	-10 (-23.3)			0 (-17.8)			10 (-12.2)			20 (-6.7)			30 (-1.1)			40 (4.4)			50 (10)			60 (15.6)		
		Capacity MBtuh		Total Sys KW*	Capacity MBtuh		Total Sys KW*	Capacity MBtuh		Total Sys KW*	Capacity MBtuh		Total Sys KW*	Capacity MBtuh		Total Sys KW*	Capacity MBtuh		Total Sys KW*	Capacity MBtuh		Total Sys KW*	Capacity MBtuh		Total Sys KW*
		Total	Integ		Total	Integ		Total	Integ		Total	Integ		Total	Integ		Total	Integ		Total	Integ		Total	Integ	
65 (18.3)	700	7.44	6.85	1.63	9.30	8.55	1.66	11.23	10.31	1.71	13.31	12.08	1.76	18.21	15.96	1.92	20.63	20.63	1.97	23.71	23.71	2.04	27.04	27.04	2.11
	800	7.58	6.97	1.63	9.27	8.52	1.67	11.18	10.26	1.70	13.26	12.02	1.75	18.25	15.99	1.89	20.68	20.68	1.94	23.80	23.80	1.99	27.18	27.18	2.05
	900	7.41	6.81	1.65	9.42	8.67	1.67	11.14	10.23	1.70	13.18	11.95	1.73	17.89	15.68	1.88	20.74	20.74	1.92	23.88	23.88	1.96	27.30	27.30	2.01
70 (21.1)	700	7.31	6.72	1.71	9.13	8.40	1.75	11.04	10.13	1.79	13.09	11.87	1.84	17.62	15.44	2.01	20.41	20.41	2.07	23.44	23.44	2.14	26.71	26.71	2.21
	800	7.35	6.76	1.71	9.17	8.44	1.74	11.07	10.16	1.78	13.12	11.90	1.84	17.72	15.53	1.98	20.45	20.45	2.03	23.52	23.52	2.09	26.85	26.85	2.15
	900	7.39	6.79	1.72	9.20	8.46	1.76	11.10	10.18	1.78	13.15	11.93	1.82	17.76	15.56	1.97	20.51	20.51	2.01	23.60	23.60	2.05	26.96	26.96	2.10
75 (23.9)	700	7.23	6.65	1.79	9.12	8.38	1.83	10.87	9.97	1.88	12.90	11.69	1.94	17.44	15.28	2.11	20.18	20.18	2.17	23.17	23.17	2.24	26.37	26.37	2.32
	800	7.30	6.70	1.79	9.09	8.37	1.83	10.98	10.08	1.87	13.01	11.81	1.92	17.60	15.42	2.08	20.23	20.23	2.13	23.24	23.24	2.19	26.50	26.50	2.25
	900	7.33	6.74	1.80	9.12	8.38	1.85	11.00	10.09	1.88	13.02	11.81	1.92	17.66	15.47	2.07	20.27	20.27	2.11	23.31	23.31	2.15	26.62	26.62	2.20

See page 22 for notes.

Manufacturer reserves the right to change, at any time, specifications and designs without notice and without obligations.



Performance Data (cont)

COOLING CAPACITY APPENDIX M1 TEST PROCEDURE

030

EVAPORATOR AIR		CONDENSER ENTERING AIR TEMPERATURES °F (°C)																	
CFM	EWB	75 (23.9)			85 (29.4)			95 (35)			105 (40.6)			115 (46.1)			125 (51.7)		
		Capacity MBtuh		Total Sys KW*	Capacity MBtuh		Total Sys KW*	Capacity MBtuh		Total Sys KW*	Capacity MBtuh		Total Sys KW*	Capacity MBtuh		Total Sys KW*	Capacity MBtuh		Total Sys KW*
		Total	Sens†		Total	Sens†		Total	Sens†		Total	Sens†		Total	Sens†		Total	Sens†	
875	57 (13.9)	27.19	27.19	2.14	26.05	26.05	2.37	24.84	24.84	2.64	23.43	23.43	2.93	21.25	21.25	3.23	19.24	19.24	3.59
	62 (16.7)	28.14	26.16	2.15	26.68	25.45	2.38	25.16	24.71	2.64	23.47	23.47	2.93	21.29	21.29	3.23	19.28	19.28	3.59
	63 (17.2)‡	28.69	21.26	2.16	27.17	20.56	2.39	25.60	19.85	2.64	23.79	19.05	2.93	20.89	17.78	3.22	18.23	16.64	3.56
	67 (19.4)	31.23	22.23	2.17	29.62	21.54	2.40	27.93	20.84	2.67	26.10	20.08	2.97	23.84	19.14	3.31	20.67	17.87	3.63
1000	71 (21.7)	33.84	18.92	2.18	32.24	18.31	2.41	30.52	17.64	2.68	28.68	16.93	2.98	26.52	16.12	3.32	23.52	15.01	3.71
	57 (13.9)	28.52	28.52	2.19	27.29	27.29	2.42	25.98	25.98	2.68	24.53	24.53	2.98	22.51	22.51	3.29	20.30	20.30	3.65
	62 (16.7)	28.91	28.24	2.19	27.43	27.47	2.42	26.02	26.02	2.68	24.57	24.57	2.98	22.56	22.56	3.30	20.34	20.34	3.65
	63 (17.2)‡	29.37	22.70	2.19	27.79	22.00	2.42	26.12	21.26	2.68	24.30	20.46	2.98	21.47	19.24	3.26	18.70	18.03	3.60
1125	67 (19.4)	31.98	23.78	2.20	30.34	23.12	2.43	28.60	22.40	2.70	26.73	21.64	3.00	24.36	20.67	3.34	21.21	19.41	3.68
	71 (21.7)	34.47	19.94	2.22	32.83	19.32	2.45	31.06	18.64	2.71	29.16	17.93	3.02	27.02	17.18	3.36	24.01	16.10	3.74
	57 (13.9)	29.65	29.65	2.23	28.33	28.33	2.46	26.95	26.95	2.73	25.48	25.48	3.02	23.68	23.68	3.37	21.21	21.21	3.71
	62 (16.7)	29.69	29.69	2.23	28.38	28.38	2.46	26.99	26.99	2.73	25.53	25.53	3.03	23.72	23.72	3.37	21.25	21.25	3.71
1125	63 (17.2)‡	29.92	24.11	2.23	28.26	23.37	2.46	26.54	22.62	2.72	24.69	21.82	3.01	21.97	20.63	3.31	19.14	19.05	3.65
	67 (19.4)	32.51	25.25	2.23	30.86	24.59	2.47	29.09	23.87	2.73	27.20	23.12	3.03	24.84	22.17	3.37	21.70	20.88	3.73
	71 (21.7)	34.91	20.88	2.25	33.25	20.26	2.48	31.44	19.59	2.75	29.47	18.89	3.05	27.34	18.13	3.39	24.45	17.17	3.77

See page 22 for notes.

HEATING CAPACITY APPENDIX M1 TEST PROCEDURE

030

INDOOR AIR		OUTDOOR COIL ENTERING AIR TEMPERATURES °F (°C)																							
EDB	CFM	-10 (-23.3)		0 (-17.8)			10 (-12.2)		20 (-6.7)		30 (-1.1)		40 (4.4)		50 (10)		60 (15.6)								
		Capacity MBtuh		Total Sys KW*	Capacity MBtuh		Total Sys KW*	Capacity MBtuh		Total Sys KW*	Capacity MBtuh		Total Sys KW*	Capacity MBtuh		Total Sys KW*	Capacity MBtuh		Total Sys KW*						
		Total	Integ		Total	Integ		Total	Integ		Total	Integ		Total	Integ		Total	Integ							
65 (18.3)	875	8.74	8.04	1.98	11.42	10.51	2.05	14.32	13.14	2.12	17.45	15.82	2.18	21.86	19.16	2.31	24.69	24.69	2.38	28.62	28.62	2.47	33.29	33.29	2.59
	1000	8.91	8.20	1.99	11.62	10.69	2.06	14.54	13.34	2.12	17.72	16.07	2.19	21.52	18.85	2.28	24.98	24.98	2.34	28.99	28.99	2.42	33.79	33.79	2.53
	1125	9.06	8.34	2.01	11.79	10.84	2.07	14.73	13.52	2.13	17.96	16.27	2.20	22.30	19.54	2.28	25.22	25.22	2.32	29.31	29.31	2.40	34.21	34.21	2.49
70 (21.1)	875	8.27	7.60	2.06	10.97	10.10	2.14	13.89	12.75	2.21	17.04	15.45	2.29	20.97	18.37	2.40	24.90	24.90	2.50	28.22	28.22	2.58	32.79	32.79	2.70
	1000	8.43	7.75	2.08	11.16	10.27	2.15	14.11	12.95	2.22	17.28	15.68	2.28	21.82	19.12	2.39	24.64	24.64	2.45	28.58	28.58	2.53	33.29	33.29	2.64
	1125	8.57	7.88	2.10	11.33	10.42	2.16	14.29	13.12	2.22	17.51	15.88	2.29	21.43	18.77	2.37	24.88	24.88	2.43	28.89	28.89	2.51	33.69	33.69	2.60
75 (23.9)	875	7.78	7.16	2.14	10.51	9.67	2.22	13.45	12.35	2.31	16.61	15.07	2.39	20.10	17.61	2.49	24.03	24.03	2.60	27.82	27.82	2.70	32.30	32.30	2.83
	1000	7.93	7.30	2.16	10.70	9.84	2.24	13.67	12.54	2.31	16.86	15.29	2.39	20.49	17.95	2.47	24.30	24.30	2.56	28.18	28.18	2.65	32.78	32.78	2.76
	1125	8.07	7.43	2.18	10.86	9.99	2.25	13.85	12.71	2.32	17.07	15.48	2.39	21.09	18.48	2.48	24.53	24.53	2.54	28.47	28.47	2.62	33.18	33.18	2.72

See page 22 for notes.

Manufacturer reserves the right to change, at any time, specifications and designs without notice and without obligations.

Performance Data (cont)

COOLING CAPACITY APPENDIX M1 TEST PROCEDURE

036

EVAPORATOR AIR		CONDENSER ENTERING AIR TEMPERATURES °F (°C)																	
		75 (23.9)			85 (29.4)			95 (35)			105 (40.6)			115 (46.1)			125 (51.7)		
		Capacity MBtuh		Total Sys KW*	Capacity MBtuh		Total Sys KW*	Capacity MBtuh		Total Sys KW*	Capacity MBtuh		Total Sys KW*	Capacity MBtuh		Total Sys KW*	Capacity MBtuh		Total Sys KW*
CFM	EWB	Total	Sens†		Total	Sens†		Total	Sens†		Total	Sens†		Total	Sens†		Total	Sens†	
		1050	57 (13.9)	34.21	34.21	2.63	32.60	32.60	2.90	30.86	30.86	3.20	28.92	28.92	3.55	26.16	26.16	3.91	23.46
62 (16.7)	35.16		32.36	2.64	33.13	31.40	2.91	31.03	30.35	3.21	28.97	28.97	3.55	26.21	26.21	3.91	23.51	23.51	4.34
63 (17.2)†	35.79		26.18	2.65	33.68	25.25	2.92	31.44	24.27	3.21	29.01	23.22	3.55	25.31	21.65	3.88	21.86	20.20	4.29
67 (19.4)	38.91		27.37	2.68	36.68	26.45	2.96	34.32	25.51	3.25	31.72	24.45	3.60	28.69	23.24	4.00	24.69	21.69	4.38
1200	71 (21.7)	41.98	23.12	2.73	39.70	22.28	2.99	37.26	21.36	3.29	34.66	20.39	3.63	31.78	19.37	4.03	27.90	17.98	4.50
	57 (13.9)	35.78	35.78	2.70	34.03	34.03	2.97	32.16	32.16	3.27	30.14	30.14	3.62	27.71	27.71	4.01	24.63	24.63	4.43
	62 (16.7)	36.08	34.91	2.70	34.09	34.09	2.97	32.21	32.21	3.27	30.18	30.18	3.63	27.79	27.79	4.02	24.68	24.68	4.43
	63 (17.2)†	36.59	27.98	2.70	34.35	27.00	2.97	32.03	26.00	3.27	29.54	24.94	3.60	25.94	23.42	3.94	22.41	21.85	4.35
1350	67 (19.4)	39.71	29.24	2.74	37.44	28.32	3.01	35.00	27.40	3.30	32.37	26.36	3.65	29.24	25.12	4.05	25.26	23.54	4.45
	71 (21.7)	42.65	24.35	2.78	40.34	23.49	3.05	37.81	22.57	3.34	35.13	21.63	3.69	32.25	20.61	4.08	28.40	19.32	4.55
	57 (13.9)	37.20	37.20	2.74	35.32	35.32	3.03	33.38	33.38	3.33	31.29	31.29	3.68	28.78	28.78	4.09	25.61	25.61	4.51
	62 (16.7)	37.23	37.23	2.75	35.41	35.41	3.03	33.43	33.43	3.33	31.34	31.34	3.68	28.83	28.83	4.09	25.66	25.66	4.51
1350	63 (17.2)†	37.24	29.71	2.75	34.93	28.72	3.02	32.46	27.66	3.32	29.94	26.58	3.66	26.50	25.09	4.01	22.70	22.70	4.41
	67 (19.4)	40.29	30.99	2.79	37.98	30.11	3.05	35.48	29.18	3.35	32.83	28.14	3.69	29.74	26.94	4.10	25.78	25.22	4.52
	71 (21.7)	43.12	25.48	2.84	40.76	24.62	3.10	38.19	23.71	3.39	35.47	22.76	3.73	32.57	21.78	4.13	28.79	20.58	4.59

See page 22 for notes.

HEATING CAPACITY APPENDIX M1 TEST PROCEDURE

036

INDOOR AIR		OUTDOOR COIL ENTERING AIR TEMPERATURES °F (°C)																							
		-10 (-23.3)			0 (-17.8)			10 (-12.2)			20 (-6.7)			30 (-1.1)			40 (4.4)			50 (10)			60 (15.6)		
		Capacity MBtuh		Total Sys KW*	Capacity MBtuh		Total Sys KW*	Capacity MBtuh		Total Sys KW*	Capacity MBtuh		Total Sys KW*	Capacity MBtuh		Total Sys KW*	Capacity MBtuh		Total Sys KW*	Capacity MBtuh		Total Sys KW*	Capacity MBtuh		Total Sys KW*
EDB	CFM	Total	Integ		Total	Integ		Total	Integ		Total	Integ		Total	Integ		Total	Integ		Total	Integ		Total	Integ	
		65 (18.3)	1050	10.19	9.38	2.25	13.27	12.21	2.37	16.66	15.29	2.47	20.40	18.50	2.57	24.84	21.77	2.68	28.94	28.94	2.78	33.67	33.67	2.89	39.24
1200	10.38		9.55	2.28	13.52	12.43	2.38	17.02	15.62	2.48	21.30	19.32	2.58	25.08	21.98	2.66	29.27	29.27	2.74	34.12	34.12	2.85	39.64	39.64	2.96
1350	10.55		9.71	2.31	13.64	12.55	2.41	17.08	15.68	2.49	20.91	18.96	2.57	25.28	22.15	2.66	29.55	29.55	2.73	34.49	34.49	2.83	39.72	39.72	2.91
70 (21.1)	1050	9.72	8.94	2.35	12.84	11.82	2.48	16.26	14.93	2.59	20.45	18.54	2.70	24.54	21.50	2.81	28.56	28.56	2.91	33.16	33.16	3.02	38.62	38.62	3.16
	1200	9.92	9.12	2.38	13.05	12.01	2.50	16.55	15.19	2.60	20.74	18.81	2.70	24.80	21.73	2.79	28.89	28.89	2.88	33.62	33.62	2.98	39.09	39.09	3.09
	1350	10.09	9.28	2.41	13.24	12.18	2.53	16.71	15.34	2.62	21.00	19.04	2.71	25.01	21.92	2.79	29.17	29.17	2.86	34.00	34.00	2.96	39.27	39.27	3.05
75 (23.9)	1050	9.18	8.45	2.45	12.36	11.37	2.59	15.80	14.51	2.70	19.48	17.67	2.81	24.18	21.19	2.94	28.15	28.15	3.04	32.64	32.64	3.15	37.99	37.99	3.30
	1200	9.38	8.63	2.48	12.58	11.57	2.61	16.05	14.74	2.72	19.82	17.98	2.81	24.48	21.45	2.93	28.50	28.50	3.01	33.10	33.10	3.11	38.51	38.51	3.22
	1350	9.56	8.79	2.51	12.77	11.75	2.64	16.27	14.93	2.73	20.06	18.19	2.82	24.72	21.66	2.92	28.78	28.78	3.00	33.48	33.48	3.09	38.76	38.76	3.18

See page 22 for notes.

Manufacturer reserves the right to change, at any time, specifications and designs without notice and without obligations.

Performance Data (cont)

COOLING CAPACITY APPENDIX M1 TEST PROCEDURE

042

EVAPORATOR AIR		CONDENSER ENTERING AIR TEMPERATURES °F (°C)																	
CFM	EWB	75 (23.9)			85 (29.4)			95 (35)			105 (40.6)			115 (46.1)			125 (51.7)		
		Capacity MBtuh		Total Sys KW*	Capacity MBtuh		Total Sys KW*	Capacity MBtuh		Total Sys KW*	Capacity MBtuh		Total Sys KW*	Capacity MBtuh		Total Sys KW*	Capacity MBtuh		Total Sys KW*
		Total	Sens†		Total	Sens†		Total	Sens†		Total	Sens†		Total	Sens†		Total	Sens†	
1225	57 (13.9)	39.36	39.36	3.03	37.60	37.60	3.35	34.84	34.84	3.67	31.88	31.88	4.02	28.84	28.84	4.39	25.57	25.57	4.76
	62 (16.7)	40.29	36.70	3.04	38.14	35.68	3.36	34.89	34.89	3.67	31.92	31.92	4.02	28.89	28.89	4.39	25.62	25.62	4.76
	63 (17.2)†	40.91	29.65	3.05	38.67	28.67	3.37	35.28	27.22	3.68	31.39	25.58	4.01	27.54	23.98	4.37	23.49	22.25	4.74
	67 (19.4)	44.36	30.95	3.07	42.01	30.01	3.39	39.28	28.93	3.73	34.83	27.16	4.06	30.54	25.50	4.41	26.29	23.86	4.76
	71 (21.7)	47.68	26.04	3.10	45.20	25.11	3.41	42.47	24.10	3.75	38.57	22.77	4.10	33.93	21.11	4.44	29.20	19.48	4.78
1400	57 (13.9)	41.13	41.13	3.10	39.23	39.23	3.42	36.97	36.97	3.77	33.39	33.39	4.09	30.07	30.07	4.45	26.63	26.63	4.81
	62 (16.7)	41.37	39.50	3.10	39.28	39.28	3.42	37.03	37.03	3.77	33.45	33.45	4.09	30.11	30.11	4.45	26.68	26.68	4.81
	63 (17.2)†	41.81	31.68	3.10	39.49	30.70	3.42	36.61	29.45	3.76	32.02	27.53	4.06	28.10	25.86	4.42	24.23	24.23	4.79
	67 (19.4)	45.19	33.01	3.12	42.75	32.05	3.44	40.00	31.00	3.77	35.60	29.31	4.12	31.10	27.56	4.46	26.81	25.76	4.81
	71 (21.7)	48.39	27.37	3.16	45.82	26.44	3.46	43.01	25.41	3.80	39.27	24.23	4.15	34.46	22.57	4.50	29.62	20.92	4.83
1575	57 (13.9)	42.54	42.54	3.15	40.64	40.64	3.47	38.34	38.34	3.81	34.70	34.70	4.15	31.13	31.13	4.50	27.50	27.50	4.86
	62 (16.7)	42.64	42.64	3.15	40.70	40.70	3.47	38.40	38.40	3.81	34.76	34.76	4.16	31.18	31.18	4.50	27.54	27.54	4.86
	63 (17.2)†	42.50	33.59	3.15	40.12	32.59	3.47	37.25	31.37	3.81	32.60	29.40	4.12	28.60	27.54	4.47	25.01	25.01	4.84
	67 (19.4)	45.79	34.94	3.17	43.30	33.98	3.48	40.51	32.94	3.82	36.17	31.33	4.18	31.63	29.50	4.51	27.59	27.59	4.86
	71 (21.7)	48.85	28.63	3.21	46.24	27.68	3.52	43.36	26.63	3.85	39.76	25.59	4.19	34.84	23.96	4.55	29.93	22.31	4.88

See page 22 for notes.

HEATING CAPACITY APPENDIX M1 TEST PROCEDURE

042

INDOOR AIR		OUTDOOR COIL ENTERING AIR TEMPERATURES °F (°C)																							
EDB	CFM	-10 (-23.3)			0 (-17.8)			10 (-12.2)			20 (-6.7)			30 (-1.1)			40 (4.4)			50 (10)			60 (15.6)		
		Capacity MBtuh		Total Sys KW*	Capacity MBtuh		Total Sys KW*	Capacity MBtuh		Total Sys KW*	Capacity MBtuh		Total Sys KW*	Capacity MBtuh		Total Sys KW*	Capacity MBtuh		Total Sys KW*	Capacity MBtuh		Total Sys KW*	Capacity MBtuh		Total Sys KW*
		Total	Integ		Total	Integ		Total	Integ		Total	Integ		Total	Integ		Total	Integ		Total	Integ		Total	Integ	
65 (18.3)	1225	12.99	11.95	2.93	16.15	14.86	2.96	19.92	18.28	3.00	25.31	22.95	3.10	29.23	25.62	3.17	34.13	34.13	3.27	39.76	39.76	3.41	46.22	46.22	3.56
	1400	13.22	12.16	2.97	16.39	15.08	2.98	20.17	18.51	3.02	25.55	23.17	3.10	29.48	25.83	3.15	34.47	34.47	3.24	40.23	40.23	3.36	46.53	46.53	3.48
	1575	13.42	12.35	3.01	16.60	15.27	3.02	20.39	18.72	3.04	25.79	23.39	3.11	29.71	26.03	3.15	34.75	34.75	3.23	40.61	40.61	3.34	46.59	46.59	3.43
70 (21.1)	1225	12.37	11.38	3.01	15.63	14.38	3.06	19.47	17.87	3.12	23.88	21.65	3.20	28.93	25.35	3.32	33.73	33.73	3.43	39.22	39.22	3.57	45.57	45.57	3.72
	1400	12.59	11.58	3.05	15.87	14.60	3.08	19.73	18.11	3.13	24.68	22.38	3.21	29.20	25.58	3.30	34.07	34.07	3.39	39.68	39.68	3.52	45.99	45.99	3.63
	1575	12.79	11.77	3.08	16.07	14.79	3.11	19.95	18.31	3.15	25.42	23.05	3.24	29.42	25.78	3.29	34.36	34.36	3.38	40.07	40.07	3.49	46.13	46.13	3.59
75 (23.9)	1225	11.72	10.78	3.10	15.08	13.88	3.16	18.99	17.43	3.24	23.38	21.20	3.35	29.35	25.72	3.50	33.32	33.32	3.59	38.68	38.68	3.73	44.89	44.89	3.89
	1400	11.94	10.98	3.13	15.32	14.09	3.19	19.25	17.67	3.26	23.67	21.46	3.34	28.91	25.33	3.46	33.66	33.66	3.55	39.13	39.13	3.68	45.38	45.38	3.80
	1575	12.13	11.16	3.17	15.53	14.29	3.22	19.48	17.88	3.28	23.92	21.69	3.35	29.13	25.52	3.45	33.95	33.95	3.53	39.52	39.52	3.65	45.59	45.59	3.75

See page 22 for notes.

Manufacturer reserves the right to change, at any time, specifications and designs without notice and without obligations.

Performance Data (cont)

COOLING CAPACITY APPENDIX M1 TEST PROCEDURE

048

EVAPORATOR AIR		CONDENSER ENTERING AIR TEMPERATURES °F (°C)																	
		75 (23.9)			85 (29.4)			95 (35)			105 (40.6)			115 (46.1)			125 (51.7)		
		CFM	EWB	Capacity MBtuh		Total Sys KW*	Capacity MBtuh		Total Sys KW*	Capacity MBtuh		Total Sys KW*	Capacity MBtuh		Total Sys KW*	Capacity MBtuh		Total Sys KW*	Capacity MBtuh
Total	Sens†			Total	Sens†		Total	Sens†		Total	Sens†		Total	Sens†		Total	Sens†		
1400	57 (13.9)	45.01	45.01	3.39	43.18	43.18	3.76	41.19	41.19	4.18	38.98	38.98	4.64	36.59	36.59	5.16	33.96	33.96	5.73
	62 (16.7)	46.17	42.25	3.41	43.94	41.16	3.77	41.56	39.98	4.18	39.12	38.79	4.65	36.64	36.64	5.16	34.00	34.00	5.73
	63 (17.2)‡	46.85	34.17	3.41	44.51	33.13	3.78	42.02	32.04	4.19	39.31	30.85	4.65	36.44	29.62	5.16	33.35	28.30	5.71
	67 (19.4)	50.18	35.40	3.44	47.63	34.35	3.81	44.92	33.25	4.23	41.99	32.06	4.69	38.90	30.83	5.20	35.57	29.51	5.75
	71 (21.7)	53.79	29.80	3.48	51.02	28.75	3.85	48.06	27.64	4.27	44.91	26.47	4.73	41.56	25.25	5.24	37.98	23.96	5.79
1600	57 (13.9)	46.74	46.74	3.47	44.77	44.77	3.84	42.61	42.61	4.26	40.23	40.23	4.72	37.69	37.69	5.24	34.89	34.89	5.80
	62 (16.7)	47.19	45.29	3.47	44.92	44.53	3.84	42.66	42.66	4.26	40.28	40.28	4.72	37.73	37.73	5.24	34.93	34.93	5.80
	63 (17.2)‡	47.66	36.32	3.48	45.22	35.26	3.84	42.63	34.13	4.25	39.82	32.92	4.71	36.86	31.65	5.22	33.68	30.28	5.78
	67 (19.4)	51.01	37.74	3.51	48.33	36.64	3.88	45.50	35.50	4.29	42.48	34.30	4.75	39.29	33.03	5.26	35.89	31.67	5.82
	71 (21.7)	54.60	31.38	3.54	51.71	30.30	3.92	48.64	29.18	4.33	45.37	27.99	4.79	41.92	26.76	5.30	38.24	25.45	5.86
1800	57 (13.9)	48.15	48.15	3.54	46.05	46.05	3.91	43.75	43.75	4.33	41.24	41.24	4.80	38.56	38.56	5.31	35.62	35.62	5.87
	62 (16.7)	48.87	45.85	3.55	46.10	46.10	3.91	43.80	43.80	4.33	41.29	41.29	4.80	38.60	38.60	5.31	35.66	35.66	5.88
	63 (17.2)‡	48.27	38.38	3.54	45.74	37.28	3.91	43.07	36.13	4.32	40.19	34.88	4.78	37.17	33.57	5.29	33.95	32.11	5.84
	67 (19.4)	51.61	39.96	3.57	48.84	38.83	3.94	45.93	37.66	4.36	42.84	36.43	4.82	39.59	35.11	5.33	36.13	33.68	5.88
	71 (21.7)	55.18	32.88	3.60	52.20	31.79	3.98	49.04	30.65	4.39	45.69	29.46	4.86	42.15	28.21	5.36	38.39	26.90	5.92

See page 22 for notes.

HEATING CAPACITY APPENDIX M1 TEST PROCEDURE

048

INDOOR AIR		OUTDOOR COIL ENTERING AIR TEMPERATURES °F (°C)																							
		-10 (-23.3)			0 (-17.8)			10 (-12.2)			20 (-6.7)			30 (-1.1)			40 (4.4)			50 (10)			60 (15.6)		
		EDB	CFM	Capacity MBtuh		Total Sys KW*	Capacity MBtuh		Total Sys KW*	Capacity MBtuh		Total Sys KW*	Capacity MBtuh		Total Sys KW*	Capacity MBtuh		Total Sys KW*	Capacity MBtuh		Total Sys KW*	Capacity MBtuh		Total Sys KW*	
Total	Integ			Total	Integ		Total	Integ		Total	Integ		Total	Integ		Total	Integ		Total	Integ		Total	Integ		
65 (18.3)	1400	16.37	15.06	3.23	20.67	19.02	3.39	24.89	22.84	3.45	29.32	26.59	3.53	34.15	29.92	3.63	39.34	39.34	3.74	45.03	45.03	3.86	51.49	51.49	3.99
	1600	16.52	15.20	3.26	20.73	19.08	3.40	24.98	22.93	3.46	29.39	26.65	3.52	34.20	29.97	3.60	39.39	39.39	3.69	45.10	45.10	3.79	51.60	51.60	3.90
	1800	16.67	15.34	3.30	20.87	19.21	3.43	25.09	23.02	3.47	29.48	26.73	3.53	34.28	30.03	3.59	39.47	39.47	3.67	45.18	45.18	3.75	51.72	51.72	3.84
70 (21.1)	1400	16.16	14.87	3.38	20.21	18.60	3.53	25.22	23.15	3.60	29.11	26.40	3.70	33.89	29.69	3.81	39.01	39.01	3.92	44.63	44.63	4.04	50.99	50.99	4.19
	1600	16.31	15.00	3.41	20.55	18.91	3.56	24.78	22.75	3.63	29.17	26.46	3.69	33.94	29.74	3.77	39.06	39.06	3.87	44.69	44.69	3.97	51.10	51.10	4.08
	1800	16.46	15.15	3.45	20.70	19.04	3.59	24.88	22.84	3.64	29.26	26.54	3.69	34.01	29.80	3.77	39.12	39.12	3.84	44.77	44.77	3.93	51.21	51.21	4.02
75 (23.9)	1400	15.96	14.68	3.53	19.95	18.35	3.70	24.93	22.89	3.77	28.89	26.20	3.89	33.63	29.47	3.99	38.68	38.68	4.11	44.23	44.23	4.24	50.50	50.50	4.39
	1600	16.11	14.82	3.56	20.08	18.48	3.71	24.96	22.91	3.77	28.96	26.26	3.87	33.67	29.51	3.96	38.73	38.73	4.05	44.28	44.28	4.16	50.59	50.59	4.28
	1800	16.23	14.93	3.60	19.84	18.26	3.72	25.04	22.99	3.78	29.04	26.34	3.87	33.74	29.57	3.95	38.79	38.79	4.03	44.35	44.35	4.12	50.70	50.70	4.22

See page 22 for notes.

Manufacturer reserves the right to change, at any time, specifications and designs without notice and without obligations.

Performance Data (cont)

COOLING CAPACITY APPENDIX M1 TEST PROCEDURE

060

EVAPORATOR AIR		CONDENSER ENTERING AIR TEMPERATURES °F (°C)																	
		75 (23.9)			85 (29.4)			95 (35)			105 (40.6)			115 (46.1)			125 (51.7)		
		CFM	EWB	Capacity MBtuh		Total Sys KW*	Capacity MBtuh		Total Sys KW*	Capacity MBtuh		Total Sys KW*	Capacity MBtuh		Total Sys KW*	Capacity MBtuh		Total Sys KW*	Capacity MBtuh
Total	Sens†			Total	Sens†		Total	Sens†		Total	Sens†		Total	Sens†		Total	Sens†		Total
1500	57 (13.9)	52.06	52.06	4.05	50.03	50.03	4.47	47.82	47.82	4.96	45.38	45.38	5.52	42.69	42.69	6.15	39.68	39.68	6.84
	62 (16.7)	54.20	48.66	4.06	51.64	47.42	4.49	48.89	46.09	4.98	45.92	44.63	5.53	42.79	42.64	6.15	39.73	39.73	6.84
	63 (17.2)‡	55.13	39.72	4.07	52.48	38.50	4.50	49.64	37.20	4.99	46.54	35.81	5.54	43.20	34.33	6.16	39.55	32.73	6.83
	67 (19.4)	59.15	41.12	4.10	56.28	39.88	4.54	53.18	38.57	5.03	49.83	37.17	5.59	46.23	35.69	6.21	42.32	34.11	6.89
	71 (21.7)	63.55	34.99	4.13	60.44	33.75	4.58	57.09	32.44	5.08	53.48	31.06	5.64	49.59	29.58	6.27	45.41	28.03	6.94
1700	57 (13.9)	54.16	54.16	4.12	51.97	51.97	4.55	49.59	49.59	5.04	46.96	46.96	5.60	44.07	44.07	6.23	40.89	40.89	6.92
	62 (16.7)	55.40	52.06	4.13	52.75	50.74	4.56	49.93	49.29	5.05	47.03	47.03	5.60	44.13	44.13	6.23	40.94	40.94	6.92
	63 (17.2)‡	56.18	42.04	4.13	53.43	40.79	4.56	50.45	39.47	5.05	47.23	38.04	5.60	43.77	36.53	6.22	40.01	34.89	6.90
	67 (19.4)	60.26	43.62	4.16	57.23	42.34	4.60	54.00	41.00	5.09	50.53	39.58	5.65	46.81	38.07	6.28	42.80	36.45	6.95
	71 (21.7)	64.69	36.70	4.19	61.44	35.45	4.64	57.94	34.12	5.14	54.19	32.71	5.71	50.16	31.21	6.33	45.86	29.64	7.01
1850	57 (13.9)	55.49	55.49	4.17	53.21	53.21	4.60	50.70	50.70	5.10	47.95	47.95	5.66	44.95	44.95	6.28	41.65	41.65	6.97
	62 (16.7)	56.19	54.44	4.17	53.50	53.01	4.60	50.77	50.77	5.10	48.02	48.02	5.66	45.00	45.00	6.29	41.70	41.70	6.98
	63 (17.2)‡	56.83	43.72	4.18	53.98	42.45	4.61	50.93	41.10	5.10	47.64	39.66	5.65	44.10	38.12	6.27	40.29	36.45	6.94
	67 (19.4)	60.90	45.42	4.20	57.80	44.13	4.65	54.49	42.77	5.14	50.95	41.33	5.70	47.15	39.80	6.32	43.07	38.15	7.00
	71 (21.7)	65.35	37.94	4.23	62.02	36.67	4.69	58.43	35.33	5.19	54.60	33.91	5.75	50.48	32.40	6.38	46.10	30.82	7.05

See page 22 for notes.

HEATING CAPACITY APPENDIX M1 TEST PROCEDURE

060

INDOOR AIR		OUTDOOR COIL ENTERING AIR TEMPERATURES °F (°C)																							
		-10 (-23.3)			0 (-17.8)			10 (-12.2)			20 (-6.7)			30 (-1.1)			40 (4.4)			50 (10)			60 (15.6)		
		EDB	CFM	Capacity MBtuh		Total Sys KW*	Capacity MBtuh		Total Sys KW*	Capacity MBtuh		Total Sys KW*	Capacity MBtuh		Total Sys KW*	Capacity MBtuh		Total Sys KW*	Capacity MBtuh		Total Sys KW*	Capacity MBtuh		Total Sys KW*	
Total	Integ			Total	Integ		Total	Integ		Total	Integ		Total	Integ		Total	Integ		Total	Integ		Total	Integ		
65 (18.3)	1500	19.99	18.39	3.77	25.02	23.04	3.93	29.40	26.98	4.11	36.06	32.71	4.29	42.04	36.84	4.46	48.71	48.71	4.65	56.36	56.36	4.89	65.50	65.50	5.20
	1700	20.41	18.77	3.81	25.43	23.41	3.96	29.79	27.35	4.11	37.33	33.85	4.30	42.46	37.20	4.42	49.23	49.23	4.59	57.04	57.04	4.80	66.39	66.39	5.08
	1850	20.51	18.88	3.84	25.53	23.48	3.96	30.05	27.58	4.12	36.67	33.25	4.27	42.74	37.45	4.41	49.57	49.57	4.57	57.46	57.46	4.76	66.95	66.95	5.02
70 (21.1)	1500	19.56	18.00	3.90	25.37	23.34	4.11	28.73	26.37	4.27	36.47	33.07	4.50	41.56	36.42	4.65	48.11	48.11	4.85	55.65	55.65	5.10	64.62	64.62	5.42
	1700	19.95	18.35	3.95	25.14	23.13	4.11	29.11	26.72	4.27	36.62	33.21	4.47	41.98	36.78	4.61	48.63	48.63	4.79	56.30	56.30	5.01	65.49	65.49	5.30
	1850	20.10	18.48	3.97	25.27	23.24	4.12	29.24	26.83	4.27	36.19	32.82	4.45	42.23	37.00	4.59	48.95	48.95	4.76	56.72	56.72	4.97	66.20	66.20	5.25
75 (23.9)	1500	19.10	17.57	4.05	23.66	21.77	4.21	27.91	25.62	4.42	33.99	30.83	4.62	41.10	36.01	4.86	47.52	47.52	5.07	54.94	54.94	5.33	63.72	63.72	5.65
	1700	19.50	17.95	4.10	24.14	22.21	4.24	28.42	26.09	4.44	35.28	32.00	4.63	41.51	36.37	4.81	48.02	48.02	5.00	55.58	55.58	5.23	64.59	64.59	5.53
	1850	19.61	18.06	4.12	24.32	22.38	4.26	28.51	26.17	4.44	34.80	31.56	4.60	41.77	36.60	4.79	48.35	48.35	4.97	55.99	55.99	5.18	65.13	65.13	5.46

See page 22 for notes.

Manufacturer reserves the right to change, at any time, specifications and designs without notice and without obligations.

\*System kW is total of indoor and outdoor unit kilowatts.

†Sensible capacities shown are based on 80°F (27°C) entering air at the indoor coil. For sensible capacities at other than 80°F (27°C), deduct 835 Btuh (245 kW) per 1000 CFM (480 L/S) of indoor coil air for each degree below 80°F (27°C), or add 835 Btuh (245 kW) per 1000 CFM (480L/S) of indoor coil air per degree above 80°F (27°C).

‡At TVA rating indoor condition (75°F edb/63°F ewb). All other indoor air temperatures are at 80°F (27°C) edb.

#### LEGEND

BF — Bypass Factor

CFM — Cubic Feet per Minute

edb — Entering Dry Bulb

ewb — Entering Wet-Bulb

<sup>h</sup>ewb — Enthalpy, entering wet bulb

<sup>h</sup>lwb — Enthalpy, leaving wet bulb

kW — Total Unit Power Input

SHC — Sensible Heat Capacity (1000 Btuh)

<sup>t</sup> = Temperature (°F)

<sup>t</sup>edb — Entering Temperature, Dry Bulb (°F)

<sup>t</sup>ldb — Leaving Temperature, Dry Bulb (°F)

<sup>t</sup>lwb — Leaving Temperature, Wet Bulb (°F)

TC — Total Capacity (1000 Btuh) (net)

#### NOTES:

1. Direct interpolation is permissible. Do not extrapolate.

2. The following formulas may be used:

$${}^t\text{ldb} = {}^t\text{edb} - \frac{\text{Sensible capacity (Btuh)}}{1.10 \times \text{CFM}}$$

$${}^t\text{lwb} = \text{Wet-bulb temperature corresponding to enthalpy air leaving evaporator coil (}^h\text{lwb)}$$

$${}^h\text{lwb} = {}^h\text{ewb} - \frac{\text{total capacity (Btuh)}}{(4.5 \times \text{CFM})}$$

Where: <sup>h</sup>ewb = Enthalpy of air entering evaporator coil

The SHC is based on 80°F (26.7°C) edb temperature of air entering indoor coil.

Below 80°F (25.7°C) edb, subtract (corr factor x CFM) from SHC.

Above 80°F (25.7°C) edb, add (corr factor x CFM) from SHC.

Correction Factor = 1.10 x (1 - BF) x (edb - 80)

**Performance Data (cont)****Filter Pressure Drop (IN. W.C.)**

FILTER SIZE in. (mm)	CFM																	
	500	600	700	800	900	1000	1100	1200	1300	1400	1500	1600	1700	1800	1900	2000	2100	2200
20X20X1 (508X508X25)	0.05	0.07	0.08	0.10	0.12	0.13	0.14	0.15	—	—	—	—	—	—	—	—	—	—
20X24X1 (508X610x25)	—	—	—	0.08	0.09	0.10	0.11	0.13	0.14	0.15	0.16	—	—	—	—	—	—	—
24X30X1 (610X762x25)	—	—	—	0.04	0.05	0.06	0.07	0.07	0.08	0.09	0.10	—	—	—	—	—	—	—
24X36X1 (610X914X25)	—	—	—	—	—	—	—	0.06	0.07	0.07	0.08	0.09	0.09	0.10	0.11	0.12	0.13	0.14

**Accessory Electric Heat Pressure Drop (IN. W.C.)**

HEATER kW	CFM							
	800	1000	1200	1400	1600	1800	2000	2200
5-20	0.033	0.037	0.042	0.047	0.052	0.060	0.067	0.075

**Wet Coil Air Delivery\***

UNIT SIZE	SPEED TAP	TAP COLOR	AIR DELIVERY†	EXTERNAL STATIC PRESSURE (in. W.C.)									
				0.1	0.2	0.3	0.4	0.5	0.6	0.7	0.8	0.9	1
24	1	BLU	SCFM	905	695	635	580	515	445	385	345	310	275
	2	PNK	SCFM	920	830	770	740	690	640	565	505	455	400
	3	RED‡	SCFM	1015	990	935	890	845	800	760	720	665	635
	4	ORN	SCFM	1060	1030	975	930	890	845	805	760	705	670
	5	BLK	SCFM	1165	1130	1085	1045	1005	965	925	890	850	810
30	1	BLU	SCFM	995	875	935	775	690	945	575	520	480	385
	2	PNK	SCFM	1055	1005	960	915	855	775	735	685	655	610
	3	RED‡	SCFM	1210	1175	1135	1085	1045	1005	925	880	840	780
	4	ORN	SCFM	1225	1180	1135	1095	1055	1010	955	880	845	815
	5	BLK	SCFM	1355	1335	1295	1255	1215	1180	1140	1100	1045	990
36	1	BLU	SCFM	1195	1165	1120	1075	1020	975	930	865	820	765
	2	PNK	SCFM	1250	1210	1165	1115	1070	1025	950	910	870	820
	3	RED‡	SCFM	1410	1370	1330	1290	1245	1205	1165	1120	1080	1020
	4	ORN	SCFM	1430	1380	1340	1295	1255	1220	1175	1135	1080	1000
	5	BLK	SCFM	1535	1495	1455	1415	1375	1335	1300	1260	1220	1155
42	1	BLU	SCFM	1400	1360	1305	1250	1200	1140	1085	1035	985	885
	2	PNK	SCFM	1455	1415	1365	1315	1260	1200	1155	1115	1070	1020
	3	RED	SCFM	1480	1425	1370	1320	1265	1215	1160	1105	1055	1030
	4	ORN	SCFM	1535	1505	1460	1410	1360	1305	1255	1210	1175	1130
	5	BLK‡	SCFM	1645	1600	1555	1500	1455	1410	1365	1315	1255	1215
48	1	BLU	SCFM	1580	1545	1515	1480	1440	1400	1360	1345	1285	1250
	2	PNK	SCFM	1645	1610	1570	1535	1500	1460	1420	1380	1345	1315
	3	RED‡	SCFM	1750	1725	1690	1655	1620	1585	1550	1510	1475	1440
	4	ORN	SCFM	1780	1755	1720	1690	1655	1625	1590	1555	1515	1480
	5	BLK	SCFM	1905	1875	1845	1815	1780	1755	1720	1685	1655	1625
60	1	BLU	SCFM	1705	1675	1635	1600	1555	1515	1470	1420	1370	1320
	2	PNK	SCFM	1755	1720	1685	1645	1605	1565	1525	1475	1430	1380
	3	RED‡	SCFM	1880	1850	1815	1775	1745	1705	1665	1625	1590	1545
	4	ORN	SCFM	1900	1875	1840	1800	1765	1730	1695	1655	1620	1575
	5	BLK	SCFM	2010	1985	1950	1915	1885	1850	1815	1780	1745	1705

\*. Air delivery values are based on operating voltage of 230v, wet coil, without filter or electric heater. Deduct filter and electric heater pressure drops to obtain static pressure available for ducting.

†. Standard Cubic Feet per Minute

‡. Factory-shipped cooling speed.

## NOTES:

1. Do not operate the unit at a cooling airflow that is less than 350 CFM for each 12,000 Btuh of rated cooling capacity. Evaporator coil frosting may occur at airflows below this point.



## Electrical Data

MODEL	NOMINAL V-PH-HZ	Voltage Range		Compressor		OFM	IFM	Nominal kW*	HeaterFLA		MCA		MOCP†
		Min	Max	RLA	LRA	FLA	FLA		208/240	208	240	208	230
24	208/230-1-60	197	253	10.3	61.6	0.9	2.9	-/-	-	-	16.7	16.7	25
								3.8/5	18	20.8	39.2	42.7	40/45
								5.6/7.5	27	31.3	50.4	55.8	60/60
								7.5/10	36.1	41.7	61.8	68.8	70/70
30	208/230-1-60	197	253	13.5	72.5	0.9	4.1	-/-	-	-	21.9	21.9	30
								3.8/5	18	20.8	44.4	47.9	45/50
								5.6/7.5	27	31.3	55.6	61	60/70
								7.5/10	36.1	41.7	67	74	70/80
36	208/230-1-60	197	253	14.7	75	1.7	4.1	-/-	-	-	24.2	24.2	35
								3.8/5	18	20.8	46.7	50.2	50/60
								5.6/7.5	27	31.3	57.9	63.3	60/70
								7.5/10	36.1	41.7	69.3	76.3	70/80
								11.3/15	54.1	62.5	91.8	102.3	100/110
42	208/230-1-60	197	253	15.9	112.3	1.7	4.1	-/-	-	-	25.7	25.7	40
								3.8/5	18	20.8	48.2	51.7	50/60
								5.6/7.5	27	31.3	59.4	64.8	60/70
								7.5/10	36.1	41.7	70.8	77.8	80/80
								11.3/15	54.1	62.5	93.3	103.8	100/110
48	208/230-1-60	197	253	18.3	130	1.7	5.1	-/-	-	-	29.7	29.7	45
								3.8/5	18	20.8	52.2	55.7	60/60
								5.6/7.5	27	31.3	63.4	68.8	70/70
								7.5/10	36.1	41.7	74.8	81.8	80/90
								11.3/15	54.1	62.5	97.3	107.8	100/110
								15/20	72.1	83.3	119.8	133.8	125/150
60	208/230-1-60	197	253	27.1	144.2	1.9	7.5	-/-	-	-	43.3	43.3	60
								3.8/5	18	20.8	65.8	69.3	70/70
								5.6/7.5	27	31.3	77	82.4	80/90
								7.5/10	36.1	41.7	88.4	95.4	90/100
								11.3/15	54.1	62.5	110.9	121.4	125/125
								15/20	72.1	83.3	133.4	147.4	150/150

\* kW @ 208/240 - Heater capacity (kW) based on heater voltage of 208v & 240v. If power distribution voltage to unit varies from rated heater voltage, heater kW will vary accordingly.

† HACR Type Circuit Breaker

### LEGEND

FLA - Full Load Amps

LRA - Locked Rotor Amps

MCA - Minimum Circuit Amps

MOCP - Maximum Overcurrent Protection

RLA - Rated Load Amps

### NOTES:

- In compliance with NEC (National Electrical Code) requirements for multimotor and combination load equipment (refer to NEC Articles 430 and 440), the overcurrent protective device for the unit shall be Power Supply fuse or circuit breaker.
- Minimum wire size is based on 60°C copper wire. If other than 60°C wire is used, or if length exceeds wire length in table, determine size from NEC.

# Typical Installation

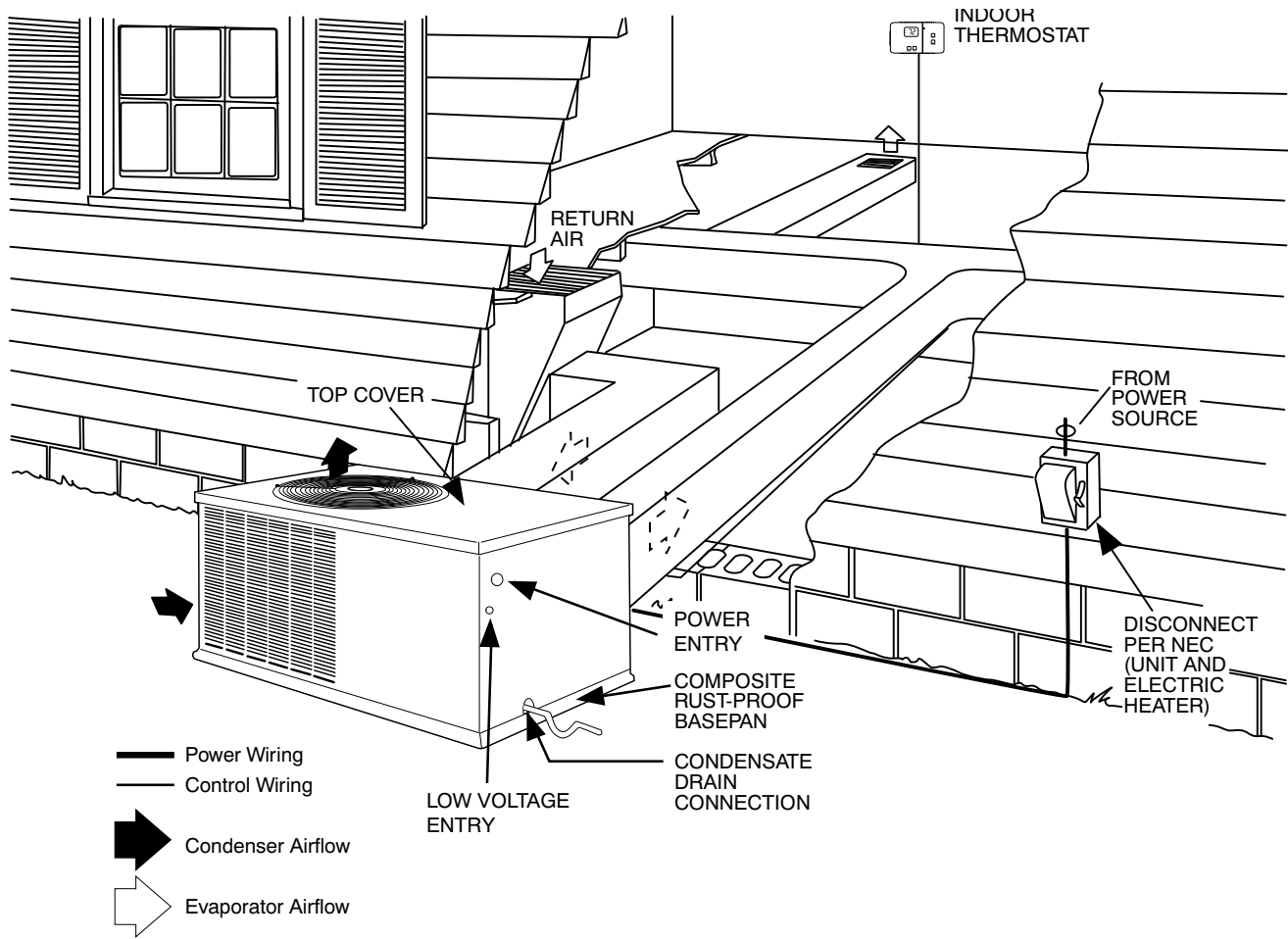

A10135

# Typical Connection Wiring Schematic

208/230-1-60

## CONNECTION WIRING DIAGRAM

**DANGER: ELECTRICAL SHOCK HAZARD DISCONNECT POWER BEFORE SERVICING**

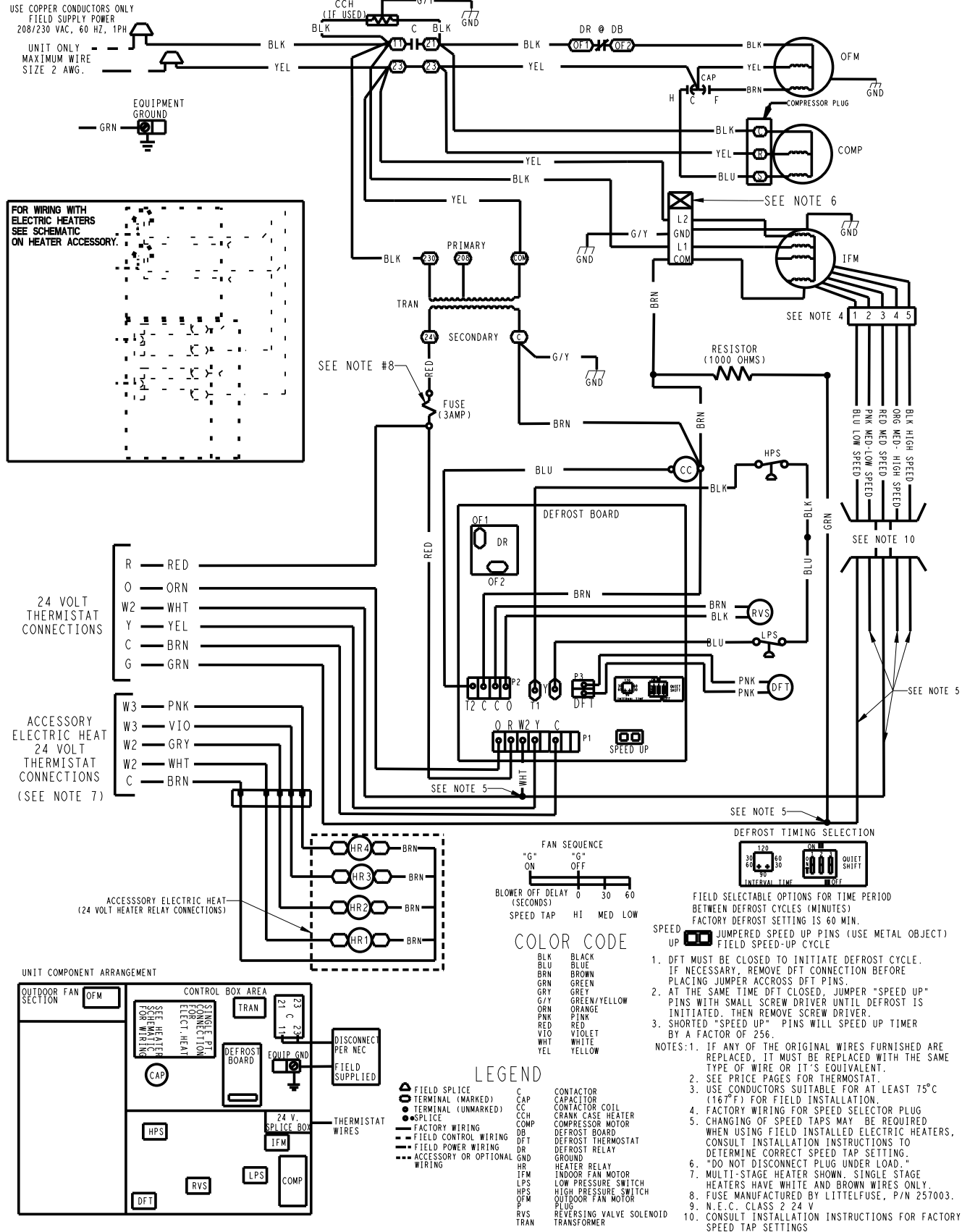



## Typical Wiring Schematic (cont)

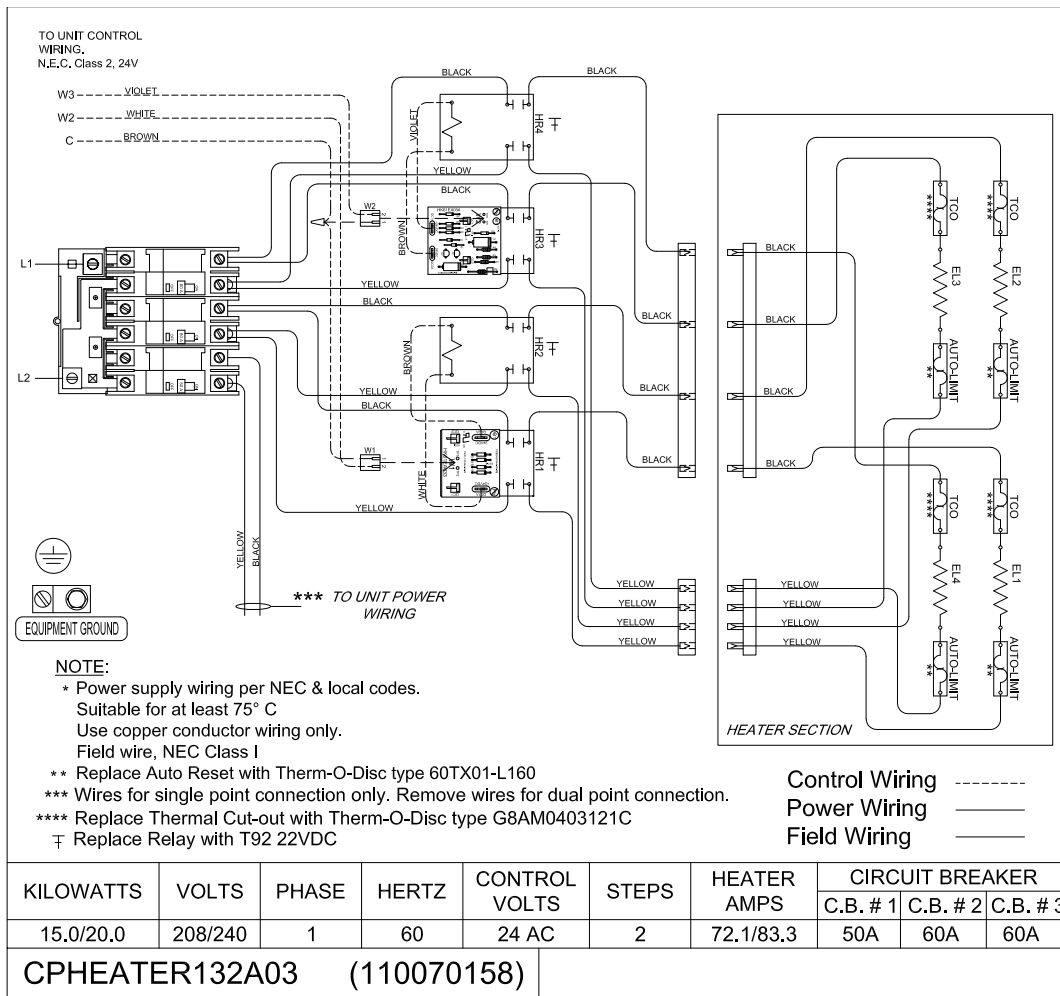

### Accessory Electric Heater Wiring

A190339

## Controls

### Sequence of operation

When power is supplied to unit, the transformer (TRAN) is energized.

**Cooling Operation** — With a call for cooling (O,Y,G), the reversing valve, contactor, and indoor fan are energized. When the cooling demand is met, Y and G are de-energized, shutting off the contactor (compressor, outdoor fan). The indoor fan stops after a 60 second delay.

**Heating Operation** — With a call for heating (Y,G), the contactor and indoor fan are energized. When the heating demand is met, Y and G are de-energized, shutting off the contactor (compressor, outdoor fan). The indoor fan stops after a 60 second delay.

**Continuous Fan** — With the continuous indoor fan option selected on the thermostat, G is continuously energized keeping the indoor fan running at all times.

**Demand Defrost Mode**— The defrost mode is factory set to an initial 60-minute time interval. It may also be adjusted to an initial interval of 30, 90, or 120 minutes. During operation, the control optimizes current defrost time based on the previous defrost interval and previous defrost period. If the previous defrost period is less than 2 minutes for two consecutive defrost cycles the control will lengthen the defrost interval by 15 minutes, up to a maximum of 120 minutes or 30 minutes greater than the original setpoint, whichever comes first. If the previous defrost period is more than 5 minutes for two consecutive defrost cycles the control will shorten the defrost interval by 15 minutes, down to a minimum of 30 minutes or 30 minutes from the original setpoint, whichever is first.

After the defrost condition is satisfied, or after a maximum of 10 minutes in defrost mode, the unit will resume normal heating operation.

### Application Data

Condensate trap — A 2-in. (51 mm) condensate trap must be field supplied.

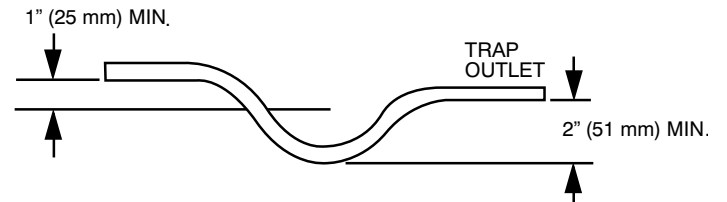

**Maximum cooling airflow** — To minimize the possibility of condensate blow-off from the evaporator, airflow through the units should not exceed 450 CFM/ton.

**Minimum cooling airflow** — The minimum cooling airflow is 350 CFM/ton.

**Minimum cooling operating outdoor air temperature** — All standard units have a minimum ambient operating temperature of 40°F (4.4°C). With accessory low ambient temperature kit, units can operate at temperatures down to 0°F (-17.8°C).

**Maximum operating outdoor air temperature** — Maximum outdoor operating air temperature for cooling is 125°F (51.7°C).

## Guide Specifications

### SMALL PACKAGED PRODUCT AIR-TO-AIR HEAT PUMP CONSTANT VOLUME APPLICATION

SIZE RANGE: 2 TO 5 TONS, NOMINAL (COOLING)

## General

### SYSTEM DESCRIPTION

Outdoor packaged, electrically controlled, air-to-air heat pump utilizing a scroll compressor for heating and cooling duty. Unit shall discharge supply air horizontally as shown on contract drawings.

### QUALITY ASSURANCE

- Unit shall be rated in accordance with AHRI Standards 210/240, and 270. Designed in accordance with UL Standard 1995.
- Unit shall be designed to conform to ASHRAE 15.
- Unit shall be UL listed as a total package for safety requirements.
- Insulation and adhesive shall meet NFPA 90A requirements for flame spread and smoke generation.

### DELIVERY, STORAGE, AND HANDLING

- Unit shall be stored and handled per manufacturer's recommendations.

## Products EQUIPMENT

### General:

Factory-assembled, single piece, air-to-air heat pump. Contained within the unit enclosure shall be all factory wiring, piping, controls, and refrigerant charge (R-410A).

### Unit Cabinet:

- Unit cabinet shall be constructed of phosphated, bonderized, zinc-coated, prepainted steel.
- Basepan shall be made of a single-piece non-corrosive, composite material.
- Indoor fan compartment cabinet surfaces shall be insulated with a minimum 1/2 in. (12.7 mm) thick, flexible insulation, coated on the air side, with aluminum foil-faced insulation.
- Cabinet panels shall be easily removable for servicing.
- Unit shall have a factory-installed, sloped, noncorrosive, condensate drain.
- Unit insulation conforms to ASHRAE 62P.

### Fans:

#### Indoor Blower (Indoor Fan):

- Fan shall be multispeed, direct drive as shown on the equipment drawings.
- Fan wheel shall be made from steel, be double-inlet type. It shall have forward-curved blades with a corrosion-resistant finish and shall be dynamically balanced.

Outdoor fan shall be of the direct-driven propeller type with aluminum blades, riveted to corrosion-resistant steel spiders. It shall be dynamically balanced, and shall discharge air upwards.

### Compressor:

- Fully-hermetic scroll type with external vibration isolation.

### Coils:

- Indoor coils shall have aluminum-plate fins mechanically bonded to seamless aluminum tubes with all joints brazed. Outdoor coils shall have copper tubes.
- Tube sheet openings shall be bellied to prevent tube wear.
- Outdoor coil shall be protected by metal louvered panels.

### Refrigerant Components:

- TXV and AccuRater feed system.
- Service gauge connections on suction and discharge lines.
- Equipped with liquid line filter drier.
- Equipped with accumulators on all sizes.

## Controls and Safeties:

### Unit Controls:

- Unit shall be complete with self-contained low voltage control circuit.
- Unit shall incorporate an outdoor coil defrost system to prevent excessive frost accumulation during heating cycle and shall be controlled as follows:
  - a. Defrost shall be initiated on the basis of time and coil temperature.
  - a. A 30/60/90/120-minute timer shall activate defrost cycle only if coil temperature is low enough to indicate a heavy frost condition.
  - b. Defrost cycle shall terminate when defrost thermostat is satisfied or shall have a positive termination time of 10 minutes.

### Safeties:

- High Pressure Switch
- Loss of Charge Switch

### Operating Characteristics:

- Unit shall be capable of starting and running at 125°F (51.7°C) ambient outdoor temperature (60 size max ambient is 115°F [46.1°C]).
- Compressor with standard controls shall be capable of operation down to 40°F (4.4°C) ambient outdoor temperature in cooling duty.
- Compressor shall be capable of operation in heating cycle down to -20°F (-28.9°C) ambient outdoor-air temperature.
- Unit shall be capable of simultaneous heating duty and defrost cycle operation when using electric heaters indicated in Section L, Special Features.

### Electrical Requirements:

All unit power wiring shall enter unit cabinet at a single location.

### Motors:

- Compressor motors shall be of the refrigerant-cooled type with line break thermal and current overload protection.
- All fan motors shall have permanently lubricated bearings and inherent automatic-reset thermal overload protection.
- Outdoor-fan motor shall be totally enclosed.

### Grille

- Louvered Grille:  
Louvered grille shall be standard on all units.

### Special Features Available

- Thermostat:  
To provide for two-stage heating and one-stage cooling in addition to manual or automatic changeover and indoor fan control.
- Low-Ambient Package:  
Shall consist of a solid-state control and outdoor coil temperature sensor for controlling outdoor fan motor operation, which shall allow unit to operate down to 0°F (-17.8°C) outdoor ambient temperature in cooling.
- Crankcase Heater:  
Shall provide anti-floodback protection for low-load cooling applications.
- Electric heaters:  
Electric heater shall be available as a field-installed option. Heater elements shall be open wire type, adequately supported and insulated with ceramic bushings. Electric heater packages must provide single point power connection capability.
- Compressor Start Kit:  
Shall be available to give a boost to the compressor motor at each start-up.
- Outdoor Thermostat Kit:  
Thermostat allows for staging of electric heaters based on outdoor air temperature.