

Zone Dampers



Turn to the experts

Product Data

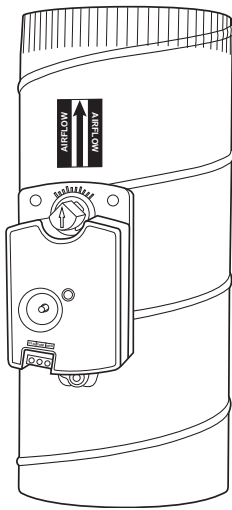

Fig. 1 – Round Damper

A05251

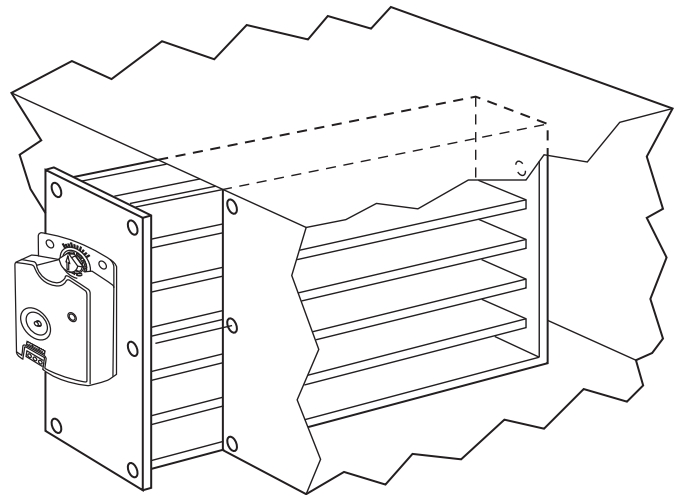

Fig. 3 – Slip-In Damper

A05253

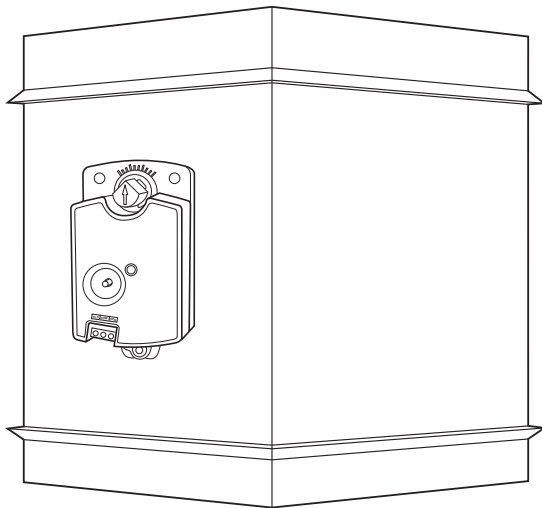

Fig. 2 – Rectangular Damper

A05252

Features/Benefits

Carrier Zone dampers are the latest in design and were developed to fit field requirements for a variety of duct work shapes and sizes. These dampers use 24 VAC direct drive actuators for smooth, quiet performance. There is a 1/2-in. direct-drive mounting hub for securing the damper blade and shaft to the actuator housing. A position indicator and angular rotation stop for viewing or manually setting minimum maximum damper positions facilitate ease of installation. A spring loaded disengagement button to momentarily release main gear and damper blade allows for manual positioning of installed dampers. The damper motor and terminal block wiring are protected by a plastic cover with a removable door. Permanently lubricated bushings, with a split shaft design for round and rectangular style dampers, secure the damper blade to the shaft for efficient reliable service.

Model Number Nomenclature

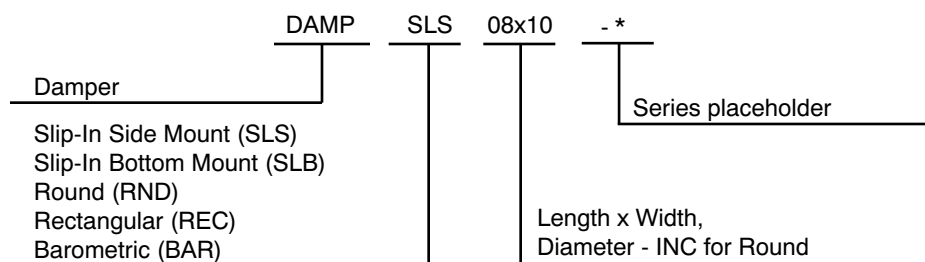

Dimensions

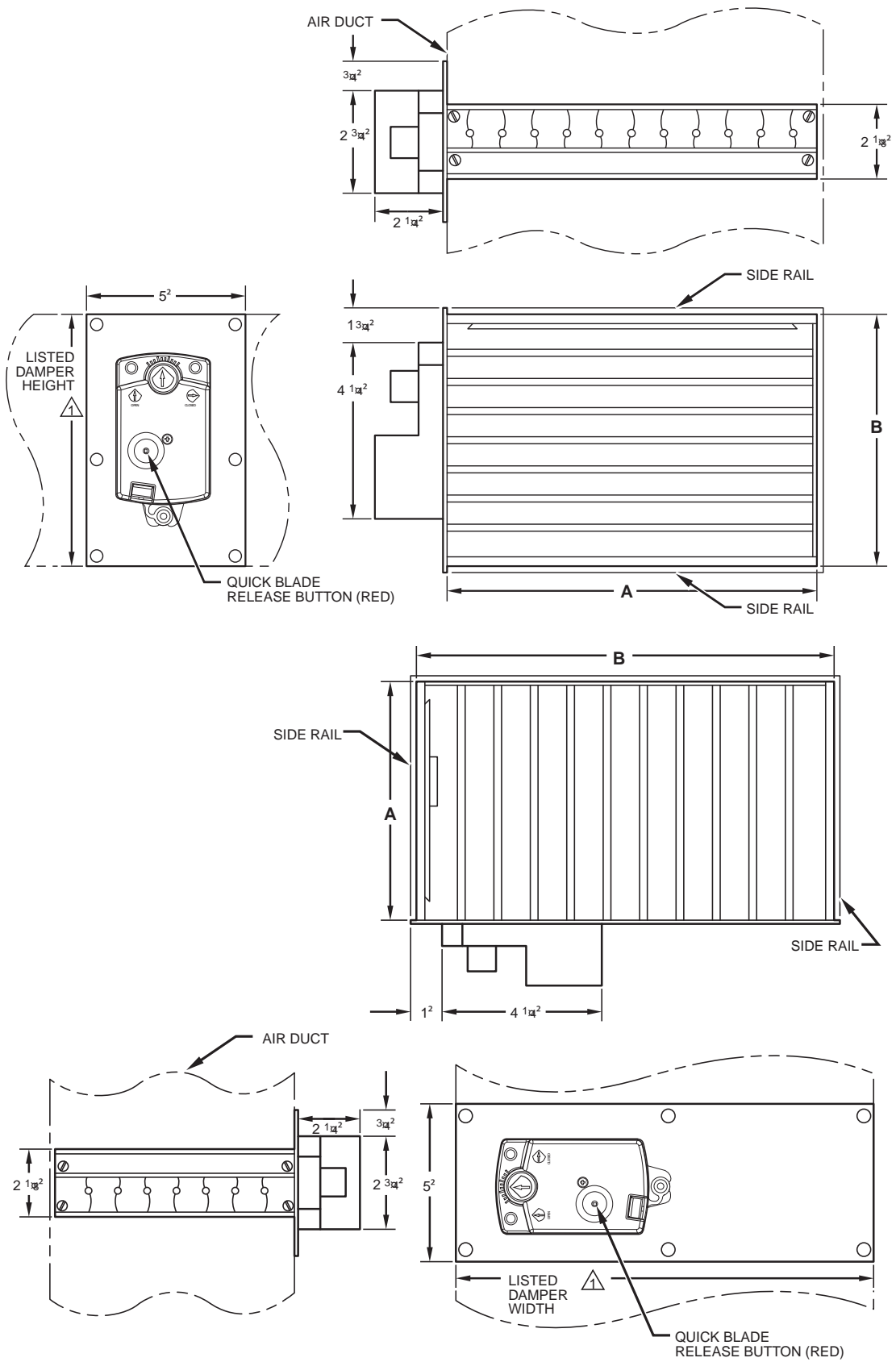

A05254

See dimensions on next page.

A05255

Dimensions Continued**Slip-In Damper Dimensions**

Part No.	Position	A	B
DAMPSLS08x08-*	side mount	7-3/8	7-13/16
DAMPSLB08x08-*	bottom mount	7-13/16	7-3/8
DAMPSLS08x10-*	side mount	9-7/8	7-13/16
DAMPSLB08x10-*	bottom mount	7-13/16	9-7/8
DAMPSLS08x12-*	side mount	11-7/8	7-13/16
DAMPSLB08x12-*	bottom mount	7-13/16	11-7/8
DAMPSLS08x14-*	side mount	13-7/8	7-13/16
DAMPSLB08x14-*	bottom mount	7-13/16	13-7/8
DAMPSLS08x16-*	side mount	15-7/8	7-3/16
DAMPSLB08x16-*	bottom mount	7-13/16	15-7/8
DAMPSLS08x18-*	side mount	17-7/8	7-13/16
DAMPSLB08x18-*	bottom mount	7-13/16	17-7/8
DAMPSLS08x20-*	side mount	7-3/8	19-13/16
DAMPSLB08x20-*	bottom mount	7-13/16	19-7/8
DAMPSLS08x22-*	side mount	7-3/8	21-13/16
DAMPSLB08x22-*	bottom mount	7-13/16	21-7/8
DAMPSLS08x24-*	side mount	7-3/8	23-13/16
DAMPSLB08x24-*	bottom mount	7-13/16	23-7/8
DAMPSLS10x10-*	side mount	9-7/8	9-13/16
DAMPSLB10x10-*	bottom mount	9-13/16	9-7/8
DAMPSLS10x12-*	side mount	11-7/8	9-13/16
DAMPSLB10x12-*	bottom mount	9-13/16	11-7/8
DAMPSLS10x14-*	side mount	13-7/8	9-13/16
DAMPSLB10x14-*	bottom mount	9-13/16	13-7/8
DAMPSLS10x16-*	side mount	15-7/8	9-13/16
DAMPSLB10x16-*	bottom mount	9-13/16	15-7/8
DAMPSLS10x18-*	side mount	17-7/8	9-13/16
DAMPSLB10x18-*	bottom mount	9-13/16	17-7/8
DAMPSLS10x20-*	side mount	9-3/8	19-13/16
DAMPSLB10x20-*	bottom mount	9-13/16	19-7/8
DAMPSLS10x22-*	side mount	9-3/8	21-13/16
DAMPSLB10x22-*	bottom mount	9-13/16	21-7/8
DAMPSLS10x24-*	side mount	9-3/8	23-13/16
DAMPSLB10x24-*	bottom mount	9-13/16	23-7/8
DAMPSLS12x12-*	side mount	11-3/8	11-13/16
DAMPSLB12x12-*	bottom mount	11-13/16	11-3/8
DAMPSLS12x14-*	side mount	11-3/8	13-13/16
DAMPSLB12x14-*	bottom mount	13-13/16	11-3/8
DAMPSLS12x16-*	side mount	11-3/8	15-13/16
DAMPSLB12x16-*	bottom mount	15-13/16	11-3/8
DAMPSLS12x18-*	side mount	11-3/8	17-13/16
DAMPSLB12x18-*	bottom mount	17-13/16	11-3/8
DAMPSLS12x20-*	side mount	11-3/8	21-13/16
DAMPSLB12x20-*	bottom mount	21-13/16	11-3/8
DAMPSLS14x14-*	side mount	13-3/8	13-13/16
DAMPSLB14x14-*	bottom mount	13-13/16	13-3/8
DAMPSLS14x16-*	side mount	13-3/8	15-13/16
DAMPSLB14x16-*	bottom mount	15-13/16	13-3/8
DAMPSLS14x20-*	side mount	13-3/8	19-13/16
DAMPSLB14x20-*	bottom mount	13-13/16	19-7/8
DAMPSLB16x16-*	side mount	15-3/8	15-13/16
DAMPSLB16x16-*	bottom mount	15-13/16	15-3/8
DAMPSLB16x20-*	bottom mount	19-13/16	15-3/8

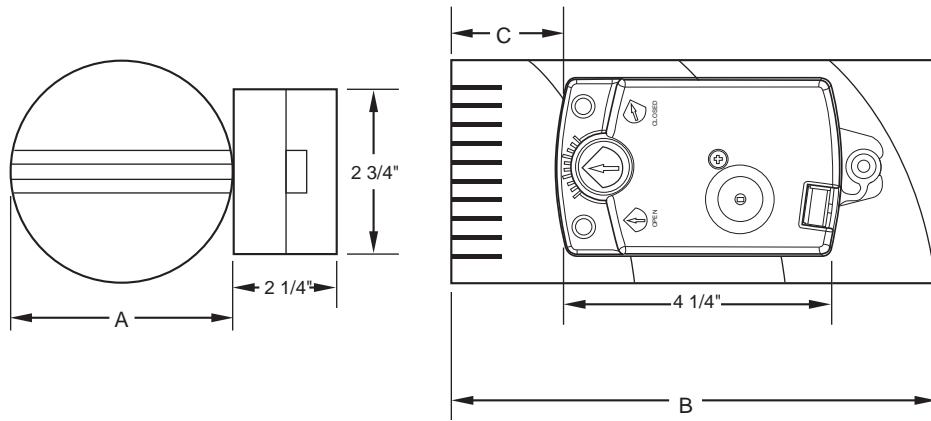

A05256

Round Damper Dimensions (in.)

Part No.	A	B	C
DAMPRND06INC-*	6	12	4-1/4
DAMPRND08INC-*	8	14	6-1/4
DAMPRND10INC-*	10	16	7-1/4
DAMPRND12INC-*	12	18	8-1/4
DAMPRND14INC-*	14	20	9-1/4
DAMPRND16INC-*	16	24	11-1/4

Dimensions Continued

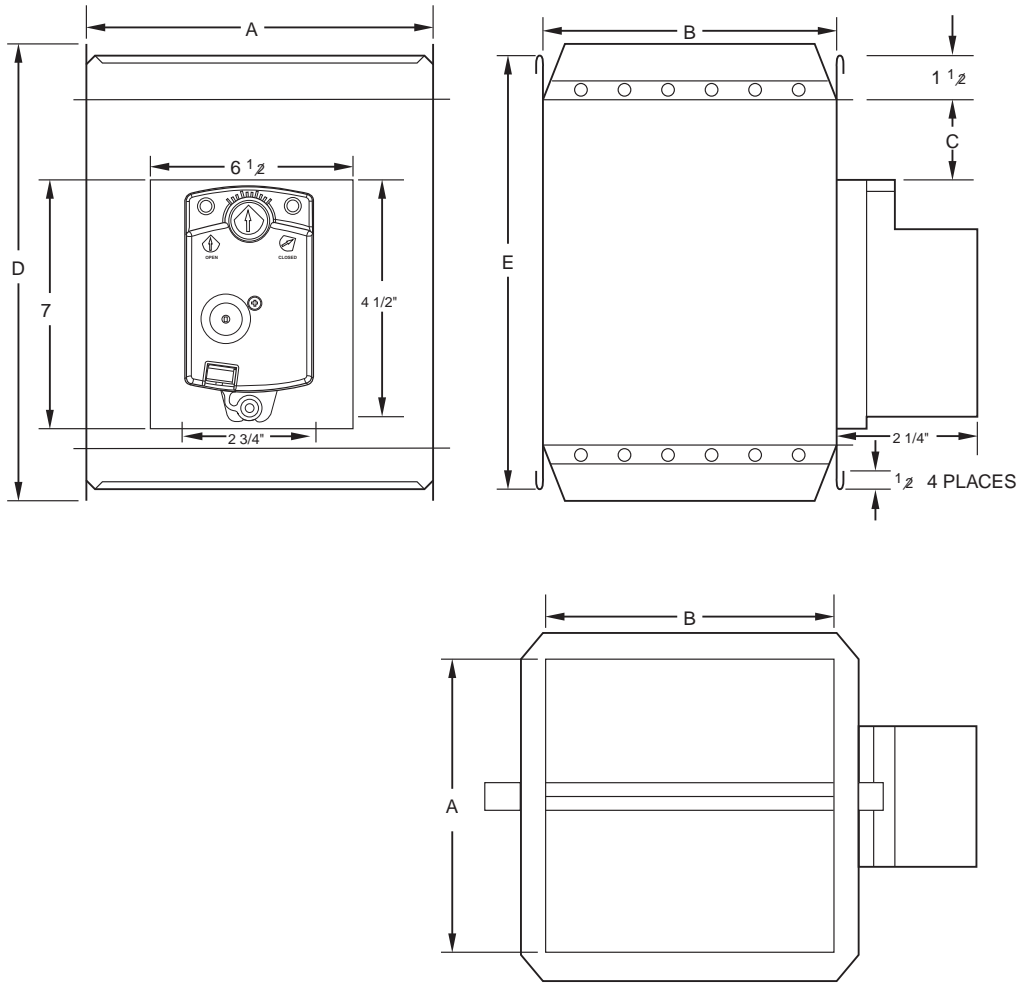

A05257

Rectangular Damper Dimensions (in.)

Part No.	A	B	C	D	E
DAMPREC08x10-*	8	10	2-1/4	13-1/2	12-1/4
DAMPREC08x14-*	8	14	2-1/4	13-1/2	12-1/4
DAMPREC08x18-*	8	18	2-1/4	13-1/2	12-1/4
DAMPREC08x24-*	8	24	2-1/4	13-1/2	12-1/4
DAMPREC10x10-*	10	10	3-1/4	15-1/2	14-1/4
DAMPREC10x14-*	10	14	3-1/4	15-1/2	14-1/4
DAMPREC10x18-*	10	18	3-1/4	15-1/2	14-1/4
DAMPREC10x24-*	10	24	3-1/4	15-1/2	14-1/4

Dimensions Continued

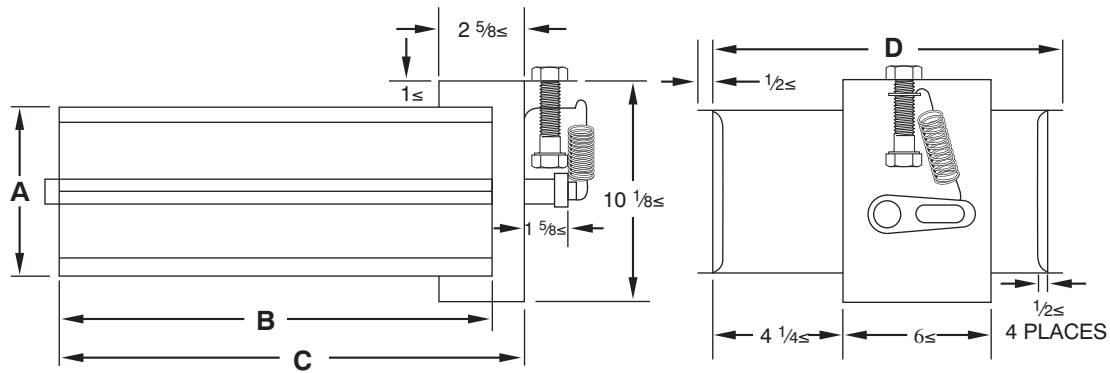

A98392

Rectangular Barometric Bypass Damper Dimensions (in.)

Part No.	A	B	C	D	Max Airflow
DAMPBAR08x14	8	14	15-1/4	13-1/2	1200 CFM
DAMPBAR08x24	8	24	25	13-1/2	1800 CFM

NOTE: Barometric Bypass Dampers are not to be used for Carrier zoning systems. (See zoning design guide for more details.)

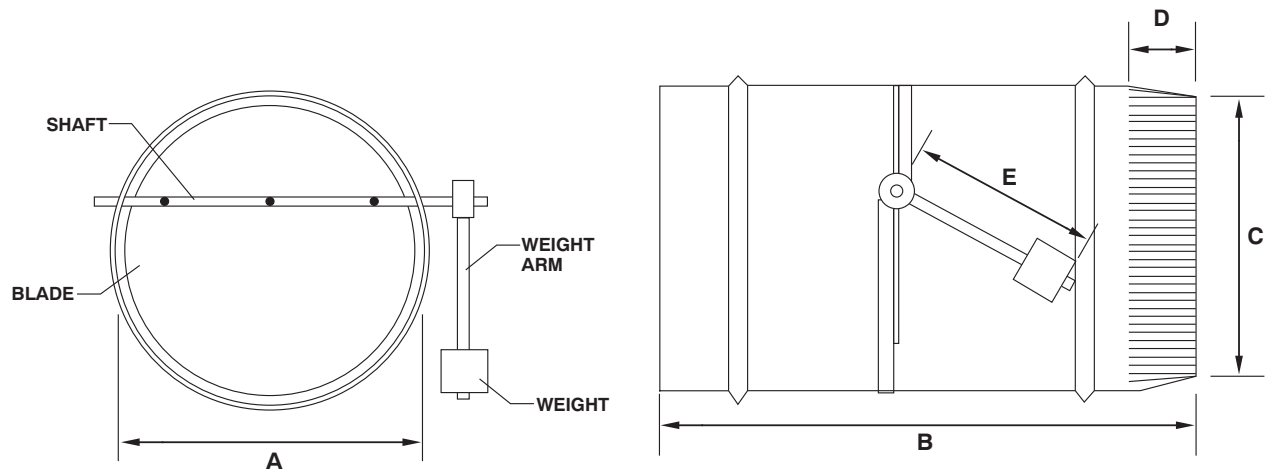

A98355

Round Barometric Bypass Damper Dimensions (in.)

Part No.	A	B	C	D	E	Number of Weights	Max Airflow
DAMPBAR08INC	8	9	7-15/16	1-1/2	6	1	400
DAMPBAR10INC	10	11-1/8	9-15/16	1-1/2	8	2	650
DAMPBAR12INC	12	13-1/8	11-15/16	1-1/2	10	2	900
DAMPBAR14INC	14	15-3/8	13-15/16	1-1/2	10	4	1200
DAMPBAR16INC	16	17-5/8	15-15/16	1-1/2	12	5	1600

NOTE: Barometric Bypass Dampers are not to be used for Carrier zoning systems. (See zoning design guide for more details.)

Physical Data

Input Voltage	24 VAC
Nominal Input Power	2 VA
Damper Output Torque	10 in. - Lb.
Ambient Temperatures	0°F to 158°F or -18°C to 70°C
Wire Connections	Common, Open, Close
Wire Connectors	Plated Screw Terminals For 14-22 AWG
Stroke Time	Angular Rotation per Sec
DAMPACT45DEG	3° per Sec
DAMPACT90DEG	6° per Sec
Travel Time	15 Sec
Barometric Bypass Pressure Range	0.2-0.8 in. wc

Damper Pressure Drop Airflow Data

Damper	400 FPM	600 FPM	800 FPM	Design Unit (CFM)	Maximum (CFM)
	In.	In.	In.		
DAMPSLS08X08-*	0.03	0.05	0.08	360	540
DAMPSLB08X08-*	0.03	0.05	0.08	360	540
DAMPSLS08X10-*	0.03	0.05	0.08	430	645
DAMPSLB08X10-*	0.03	0.05	0.08	430	645
DAMPSLS08X12-*	0.03	0.05	0.08	520	780
DAMPSLB08X12-*	0.03	0.05	0.08'	520	780
DAMPSLS08X14-*	0.03	0.05	0.08	610	915
DAMPSLB08X14-*	0.03	0.05	0.08	610	915
DAMPSLS08X16-*	0.03	0.05	0.08	700	1050
DAMPSLB08X16-*	0.03	0.05	0.08	700	1050
DAMPSLS08X18-*	0.03	0.05	0.08	780	1170
DAMPSLB08X18-*	0.03	0.05	0.08	780	1170
DAMPSLS08X20-*	0.03	0.05	0.08	890	1330
DAMPSLB08X20-*	0.03	0.05	0.08	870	1305
DAMPSLS08X22-*	0.03	0.05	0.08	980	1470
DAMPSLB08X22-*	0.03	0.05	0.08	960	1440
DAMPSLS08X24-*	0.03	0.05	0.08	1070	1600
DAMPSLB08X24-*	0.03	0.05	0.08	1050	1575
DAMPSLS10X10-*	0.03	0.05	0.08	540	810
DAMPSLB10X10-*	0.03	0.05	0.08	540	820
DAMPSLS10X12-*	0.03	0.05	0.08	650	975
DAMPSLB10X12-*	0.03	0.05	0.08	650	975
DAMPSLS10X14-*	0.03	0.05	0.08	760	1140
DAMPSLB10X14-*	0.03	0.05	0.08	760	1140
DAMPSLS10X16-*	0.03	0.05	0.08	870	1305
DAMPSLB10X16-*	0.03	0.05	0.08	870	1305
DAMPSLS10X18-*	0.03	0.05	0.08	980	1470
DAMPSLB10X18-*	0.03	0.05	0.08	980	1470
DAMPSLS10X20-*	0.03	0.04	0.06	1110	1670
DAMPSLB10X20-*	0.03	0.04	0.06	1090	1635
DAMPSLS10X22-*	0.03	0.04	0.06	1220	1830
DAMPSLB10X22-*	0.03	0.04	0.06	1200	1800
DAMPSLS10X24-*	0.03	0.04	0.06	1330	2000
DAMPSLB10X24-*	0.03	0.04	0.06	1300	1950
DAMPSLS12X12-*	0.03	0.04	0.06	800	1200
DAMPSLB12X12-*	0.03	0.04	0.06	800	1200
DAMPSLS12X14-*	0.03	0.04	0.06	930	1400
DAMPSLB12X14-*	0.03	0.04	0.06	930	1400
DAMPSLS12X16-*	0.03	0.04	0.06	1070	1600
DAMPSLB12X16-*	0.03	0.04	0.06	1070	1600
DAMPSLS12X18-*	0.03	0.04	0.06	1200	1800
DAMPSLB12X18-*	0.03	0.04	0.06	1200	1800
DAMPSLS12X20-*	0.03	0.04	0.06	1330	2000
DAMPSLB12X20-*	0.03	0.04	0.06	1330	2000
DAMPSLS14X14-*	0.03	0.04	0.06	1090	1630
DAMPSLB14X14-*	0.03	0.04	0.06	1090	1630
DAMPSLS14X16-*	0.03	0.04	0.06	1240	1870
DAMPSLB14X16-*	0.03	0.04	0.06	1240	1870
DAMPSLS14X20-*	0.02	0.03	0.05	1560	2330
DAMPSLB14X20-*	0.02	0.04	0.06	1530	2295
DAMPSLS16X16-*	0.02	0.03	0.05	1420	2130
DAMPSLB16X16-*	0.02	0.03	0.05	1420	2130
DAMPSLB16X20-*	0.02	0.03	0.05	1780	2670
DAMPRND06INC-*	0.02	0.04	0.06	120	180
DAMPRND08INC-*	0.02	0.03	0.05	220	330
DAMPRND10INC-*	0.02	0.03	0.04	490	650

Manufacturer reserves the right to change, at any time, specifications and designs without notice and without obligations.

Damper Pressure Drop Airflow Data (Continued)

Damper	400 FPM	600 FPM	800 FPM	Design Unit (CFM)	Maximum (CFM)
	In.	In.	In.		
DAMPRND12INC-*	0.02	0.03	0.04	700	1050
DAMPRND14INC-*	0.02	0.03	0.03	960	1440
DAMPRND16INC-*	0.02	0.03	0.03	1250	1875
DAMPREC08X10-*	0.02	0.03	0.04	500	750
DAMPREC08X14-*	0.02	0.03	0.04	700	1050
DAMPREC08X18-*	0.02	0.03	0.04	900	1350
DAMPREC08X24-*	0.02	0.03	0.04	1200	1800
DAMPREC10X10-*	0.02	0.02	0.02	620	930
DAMPREC10X14-*	0.02	0.02	0.02	870	1305
DAMPREC10X18-*	0.02	0.02	0.02	1120	1680
DAMPREC10X24-*	0.02	0.02	0.02	1500	2250

Note: As the design airflow for dampers is exceeded, the potential for airflow noise problems increases.

HOW TO USE PRESSURE DROP DATA

1. Calculate airflow for each zone based on load and number of zones.
2. As duct system is designed, calculate pressure losses in each duct run and in the air handler (filter and cooling coil).
3. Based on the duct size and amount of airflow required in each zone, calculate a duct velocity for the air through the damper.
4. Use the chart to find the pressure drop for the damper and the calculated velocity in each duct run.
5. Put the damper pressure drop data into the duct losses for each run and calculate a total system pressure loss.
6. Make sure that the unit specified for the application will supply the required amount of air for the calculated system pressure loss.
7. Make sure that the maximum airflow for each damper is not exceeded.

Example:

Assume an installation requires a maximum airflow of 600 CFM per zone.

If 8-in. x 18-in. ducts are used in the house the duct area is 8-in. x 18-in. / (144 sq in. per sq ft) gives 1.0 sq ft of duct area.

Dividing the airflow for each zone (600 CFM) by the duct area (1.0 sq ft) gives 600 fpm.

DAMPREC08X18: 0.03-in.

DAMPRLS08X18: 0.05-in.

DAMPRLB08x18: 0.05-in.

Bottom mount slip-in dampers were chosen for this installation. Therefore 0.05-in. of pressure drop should be added to each duct run.

Training

My Learning Center is your central location for professional residential HVAC training resources that help strengthen careers and businesses. We believe in providing high quality learning experiences both online and in the classroom.

Access My Learning Center with your HVACpartners credentials at www.mlctraining.com. Please contact us a mylearning@carrier.com with questions.