

GFK-1

Grease Fitting Kit for Hard To Reach Places

▶ SAVES TIME!
 ▶ EASY TO INSTALL

NEW GREASE FITTING
 LOCATION ALLOWS
 FOR EASY SERVICE!

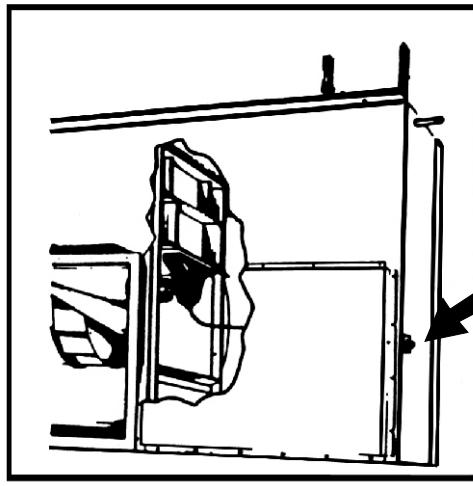

KIT CONTENTS

10' HIGH OF HIGH PRESSURE
 TUBING AND ALL THE
 NECESSARY FITTINGS.

FITTINGS



2 - 1/8 MPT x 1/4
 Compression Connectors



2 - 1/4 Compression Nuts



2 - Compression Sleeves

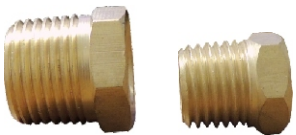

1 - 1/4 x 1/8 Reducing Bushing
 1 - 3/8 x 1/8 Reducing Bushing

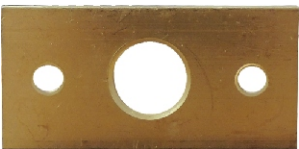

1 - Mounting Plate



1 - Jam Nut

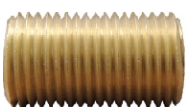

1 - Threaded Adapter



1 - Grease Fitting



2 - Screws

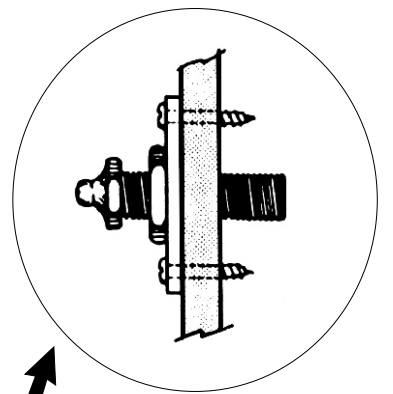
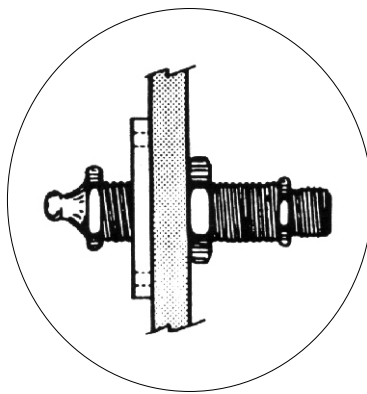

Drill 2 1/8" holes for sheet
 metal screws when rear of
 wall is not accessible.

INSTRUCTIONS

1. Remove old grease fitting.
2. Install 1/8 MPT x 1/4 Compression Connector.
 (Use Reducing Bushing if required)
3. Attach tube using a Compression Nut and Sleeve.
4. Drill a 1/2" hole in the selected location where you
 desire to install this "EASY ACCESS" Grease Fitting.
5. Assemble the mounting plate and Jam nut for installation
 shown above...either Figure "A" or Figure "B".
6. Install 2nd 1/8 MPT x 1/4 Compression Connector to
 Threaded Adapter.
7. Attach tube using 2nd 1/4 Compression Nut and Sleeve.
8. Install new Grease Fitting...Lubricate.

Saves Time!
Easy To Use!

- A** 1/4 Compression Nut
- B** Compression Sleeve
- C** 1/8 MPT x 1/4
 Compression Connector
- D** Reducing Bushing
 When Required

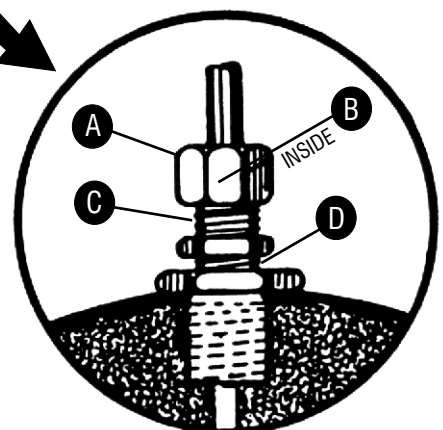

Sealed Unit Parts Co., Inc.
 PO Box 21, 2230 Landmark Place
 Allenwood, NJ 08720 USA
 www.supco.com

Made by SUPCO®
 Ningbo, China
 P/N 10167 Rev. 06222016