



## Product Data

# AquaEdge® High-Efficiency Semi-Hermetic Centrifugal Liquid Chillers

300 to 700 Nominal Tons  
(1,055 to 2,461 kW)



**AQUAEDGE** greenspeed 



19MV 50/60 Hz  
High-Efficiency Semi-Hermetic Centrifugal Liquid  
Chillers with Greenspeed® Intelligence, PIC6 Controls,  
and R-515B, R-513A, or R-134a refrigerant

The 19MV AquaEdge® chillers offer:

- The use of non-ozone depleting refrigerant R-515B, R-513A, and R-134a
- Two-stage back-to-back EquiDrive™ semi-hermetic compressor (300 to 700 tons)
- Dual EXV, variable orifice metering device
- Air cooled variable speed drive
- Positive pressure design with compact footprint
- Modular construction
- Carrier offers a five year refrigerant warranty (Domestic and Canada only).
- Magnetic bearings

The AquaEdge chiller’s high efficiencies are obtained in real-world operating conditions. Therefore, the effects of potential or indirect global warming are greatly diminished.

## High efficiency

Today’s owners of chilled water plants demand high efficiency from their chillers. As a result, the AquaEdge centrifugal chiller is offered as a variable-speed machine with a unit-mounted variable speed drive and permanent magnet motor to maximize part load efficiency.

## Environmental leadership

Carrier has long been committed to the environment and its sustainability. AquaEdge chillers provide our customers with a high-efficiency, chlorine-free solution. Carrier’s decision to utilize non-ozone depleting R-515B, R-513A, and R-134a refrigerant provides our customers with a safer and more environmentally balanced choice without compromising efficiency.

## Reliability

The AquaEdge chiller’s two-stage positive pressure EquiDrive™ back-to-back compressor, coupled with ASME (American Society of Mechanical Engineers) constructed heat exchangers, ensures high reliability and sustainability. Carrier’s semi-hermetic motors operate in a clean, refrigerant cooled environment. The semi-hermetic design eliminates the potential shaft seal leaks and refrigerant loss. These are just some of the reasons why the AquaEdge family of chillers has one of the industry’s lowest leak rates.

The AquaEdge chiller’s two-stage positive pressure EquiDrive™ back-to-back compressor, coupled with ASME constructed heat exchangers, ensures high reliability.

## Operating range

The 19MV chiller’s EquiDrive two-stage back-to-back compressor provides MORE (More Operating Range and high efficiency at design conditions) providing the flexibility to operate outside of design conditions to keep your building cool under pressure including operation down to 10% load without hot gas bypass (select models).

In addition the 19MV chiller’s frequent start feature and dual EXVs sized to enable low lift operation at full load make the 19MV an ideal fit for chilled water systems with an integrated water side economizer.

## Semi-hermetic compressor features

Magnetic bearings are integrated into the direct drive motor assembly. Motor is semi-hermetically sealed from the machine room; cooling is accomplished by spraying liquid refrigerant on the motor windings.

This highly efficient motor cooling method results in the use of smaller, cooler-running motors than could be realized with air-cooled designs of the same type.

In addition, Carrier’s semi-hermetic design eliminates:

- Compressor shaft seals that require maintenance and increase the likelihood of refrigerant leaks
- Shaft alignment problems that occur with open-drive designs during startup and operation, when equipment temperature variations cause thermal expansion
- High noise levels that are common with air-cooled motors, which radiate noise to the mechanical room and adjacent areas
- Mechanical room cooling requirements associated with air-cooled motors, which dissipate heat to the mechanical room

## Optional shipment with factory charge

The oil free design enables the AquaEdge 19MV chillers to be shipped with a full refrigerant charge without the need for isolation valves. The AquaEdge chiller can be shipped fully charged, minimizing start-up and maintenance time. Purge units are not required. The tight construction of the AquaEdge centrifugal chiller ensures that contaminants stay out and efficiency is maintained throughout the life of the chiller.

## Positive pressure design

The AquaEdge chiller’s positive pressure design reduces the chiller size by up to 35% compared to low-pressure designs. The smaller size minimizes the need for valuable mechanical room floor space. In addition, positive pressure designs eliminate the need for costly low-pressure containment devices, reducing the initial cost of the system.

## Modular construction

The AquaEdge 19MV chiller is designed to fit through a 72 inch by 80 inch opening completely assembled (heat exchanger frame sizes 3 and 4). For smaller spaces, the evaporator, condenser, and compressor assemblies are completely bolted together, making the AquaEdge chillers ideally suited for replacement projects where ease of disassembly and reassembly at the job-site are essential.

# Table of contents

Features/Benefits . . . . .	Page 2
Model Number Nomenclature . . . . .	5
Chiller Components . . . . .	6
Physical Data . . . . .	8
Options and Accessories . . . . .	9
Dimensions . . . . .	10
Selection Procedure . . . . .	11
Controls . . . . .	12
Application Data . . . . .	14
Guide Specifications . . . . .	22

## Marine container shipment (19MV, heat exchanger frame sizes 3 and 4 only)

The compact design allows for open-top container shipment to export destinations, ensuring product quality while reducing shipping cost.

Compressors are 100% run-tested to ensure proper operation of all compressor systems, including vibration, electrical, and compression.

Air-cooled VFD (variable frequency drive) is designed to be cooled without cooling water or refrigerant. Enclosure reduces the risk of exposure of electrical components to dirt, dust, moisture and splashing water. Using air instead of water also eliminates costly maintenance associated with the water cooling pump, heat exchanger, and rubber tubing used with water-cooled VFDs.

High-efficiency permanent magnet motor provides high efficiency at full and part loads.

## Heat exchanger features

The American Society of Mechanical Engineers (ASME) standard requires the use of an independent agency to certify the design, manufacture, and testing of all heat exchangers, ensuring the ultimate in heat exchanger safety, reliability, and long life. Optional 1 in. tubes provide optimized cost and less pressure drop than the standard 3/4 in. tubes. Tube expansion at center support sheets prevents unwanted tube movement and vibration, thereby reducing the possibility of premature tube failure. Double-grooved tube sheet holes reduce the possibility of leaks between the water and refrigerant system, increasing product reliability. Condenser baffle prevents direct impingement of high velocity compressor gas onto the condenser tubes. The baffle eliminates related vibration and wear of the tubes and distributes the refrigerant flow evenly over the length of the vessel for improved efficiency. Closely spaced intermediate support sheets prevent tube sagging and vibration, thereby increasing heat exchanger life.

Refrigerant filter drier isolation valves allow filter replacement without pumping down the chiller, which means less service time and less expense.

The Sensible Subcooler located in the bottom of the condenser increases the refrigeration effect by cooling condensed liquid refrigerant to a lower temperature, resulting in reduced compressor power consumption.

Dual Expansion Valves (EXV) provide precise refrigerant metering over a wide variety of operating conditions. As a result, optimal refrigerant levels can be maintained in the condenser and evaporator to achieve the greatest efficiency without unintentional hot gas bypass or flooding. The dual EXVs provide full capacity (up to 700 tons) at low lift conditions.

## Microprocessor control features

The 10.4 in. native BACnet<sup>1</sup> touchscreen direct digital Product Integrated Control (PIC6) provides unmatched flexibility, functionality, and seamless integration with the Carrier i-Vu<sup>®</sup> Building Automation and Control System supporting BACnet and Carrier Comfort Network<sup>®</sup> (CCN) communication protocols. The PIC6 control can be configured to display units in English or metric, and offers an “all-in-one” view of key chiller operational data, simplifying the interaction between the chiller and user.

Features include:

- Display of over 125 operating, status, and diagnostic messages for improved user experience
- Monitoring of over 100 functions and parameters to protect the chiller from abnormal conditions
- Modular pull-out/plug-in design, reducing wiring requirements and providing easy installation
- Low-voltage (24 v) design, providing the ultimate assurance of personal safety and control integrity
- Display mode uses English and Chinese.

Automatic capacity override function unloads the compressor whenever key safety limits are approached, increasing unit life.

Chilled water reset can be accomplished manually or automatically from the building management system. Reset saves energy when warmer chilled water can be used. Demand limiting feature limits the power draw of the chiller during peak loading conditions. When incorporated into the Carrier Comfort Network building automation system, a red line command holds chillers at their present capacity and prevents any other chillers from starting. If a load shed signal is received, the compressors are unloaded to avoid high demand charges whenever possible.

Ramp loading ensures a smooth pull-down of water loop temperature and prevents a rapid increase in compressor power consumption during the pull-down period.

Automated controls test can be executed prior to start-up to verify that the entire control system is functioning properly.

The 365-day real time clock feature allows the operator to program a yearly schedule for each week, weekends, and holidays.

Occupancy schedules can be programmed into the controller to ensure that the chiller only operates when cooling is required.

Extensive service menu features include password protection to prevent unauthorized access to the service menu. Built-in diagnostic capabilities assist in troubleshooting and recommend proper corrective action for pre-set alarms, resulting in greater operating time.

Alarm file maintains the last 25 time and date-stamped alarm and alert messages in memory; this function reduces troubleshooting time and cost. Configuration data backup in nonvolatile memory provides protection during power failures and eliminates time-consuming control reconfiguration.

---

1. Third-party trademarks and logos are the property of their respective owners.

## Refrigeration Cycle

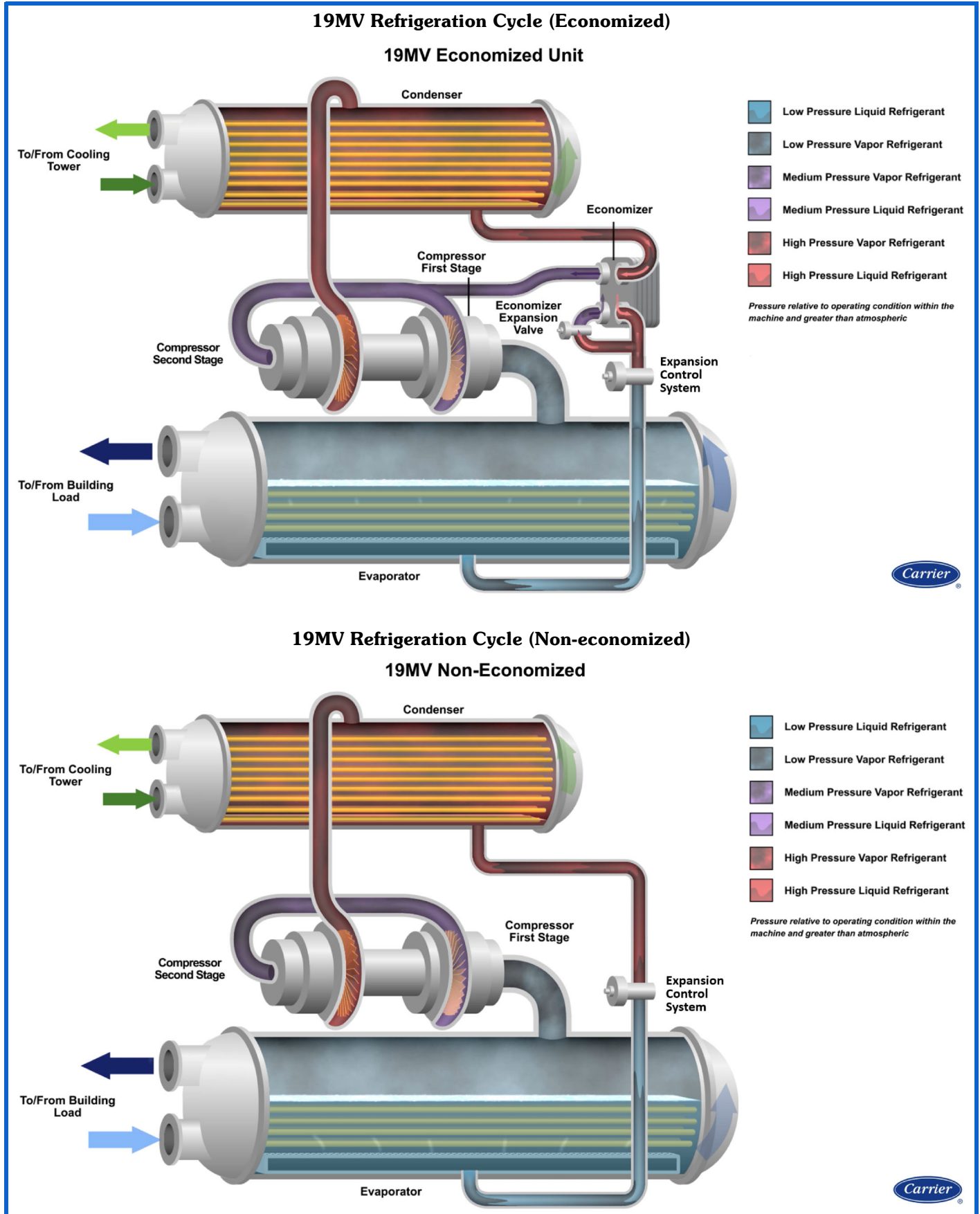

# Model number nomenclature



## 19MV Two-Stage Compressor

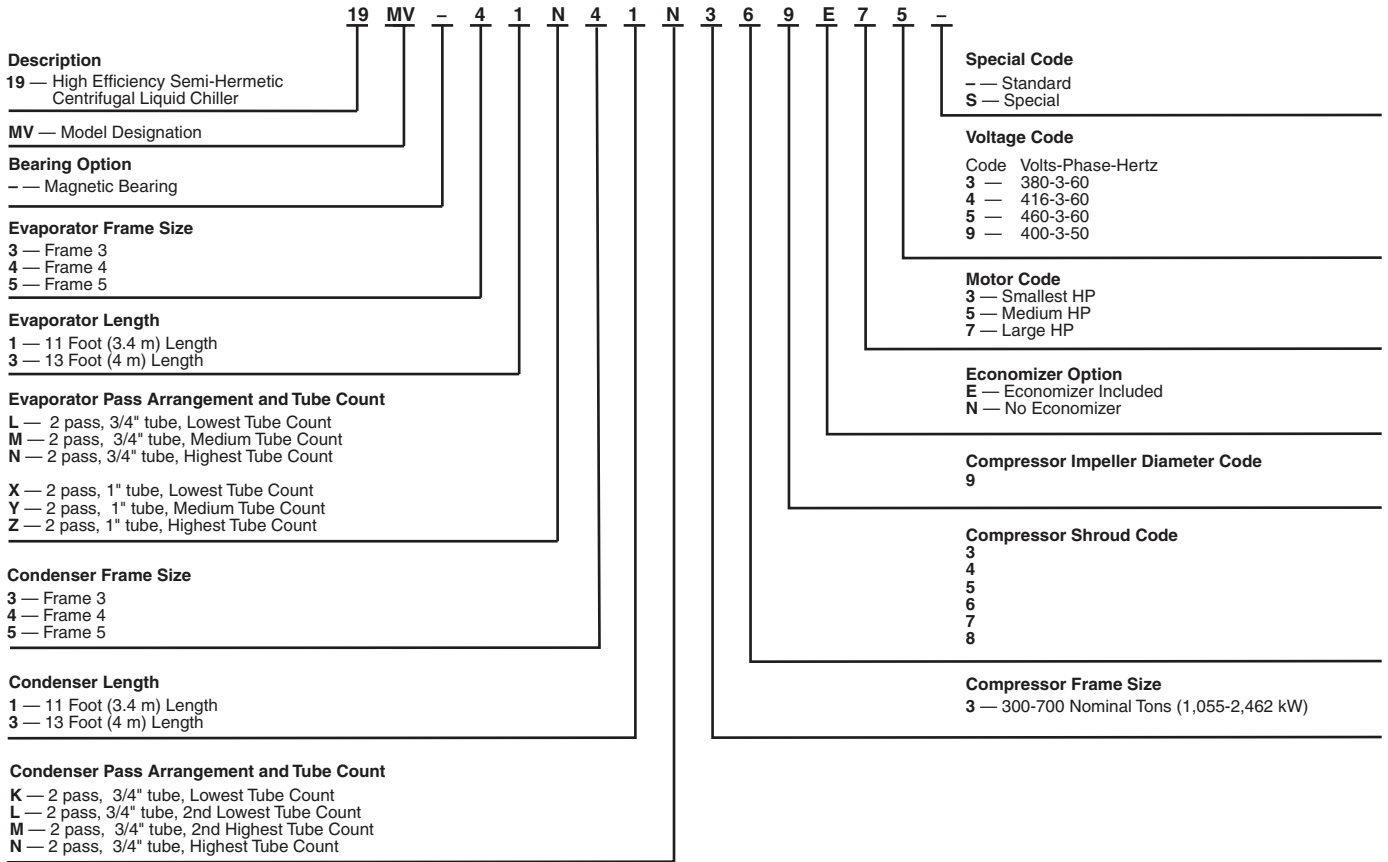

### Quality Assurance

ISO 9001:2015-certified processes

AHRI (Air-Conditioning, Heating, and Refrigeration Institute) Performance Certified

## Compressor Components

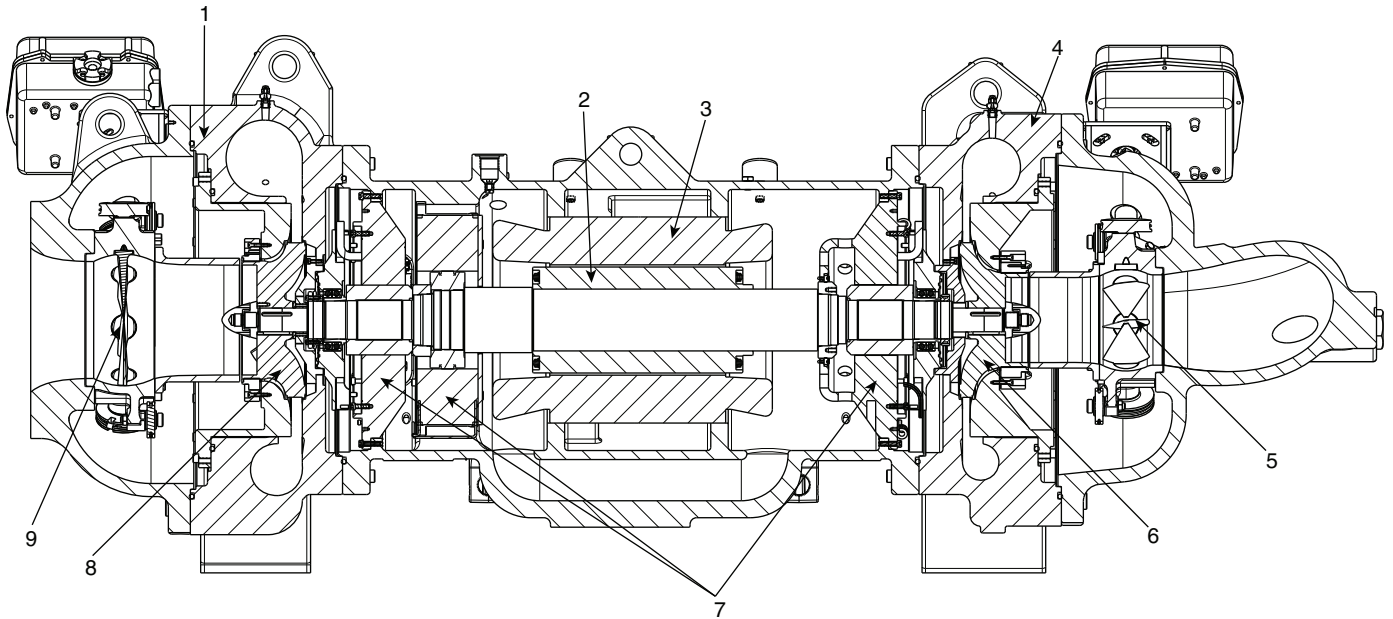

### LEGEND

- 1 — First Stage Volute
- 2 — Permanent Magnet Motor Rotor
- 3 — Motor Stator
- 4 — Second Stage Volute
- 5 — Second Stage Inlet Guide Vane
- 6 — Second Stage Impeller
- 7 — Magnetic Bearing System
- 8 — First Stage Impeller
- 9 — First Stage Inlet Guide Vane

## Chiller Components

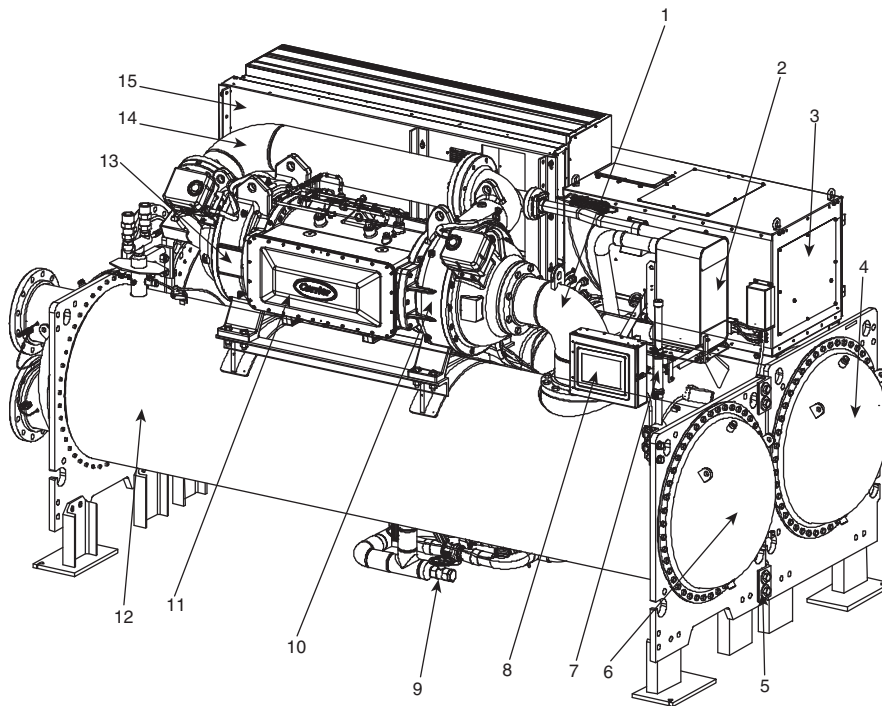

### LEGEND

- 1 — Suction Elbow 1st Stage
- 2 — Refrigerant Economizer
- 3 — Integrated Power and Control Panel
- 4 — Condenser Waterbox Return End
- 5 — Bolt Together Plate
- 6 — Evaporator Waterbox Return End
- 7 — HMI Adjustment Arm
- 8 — 10.4 in. Color Touchscreen Display
- 9 — Refrigerant Charging Valve
- 10 — EquiDrive™ Two-stage Back-to-Back Centrifugal Compressor
- 11 — Permanent Magnet Motor (hidden)
- 12 — Evaporator
- 13 — Magnetic Bearing System
- 14 — Interstage Compressor Piping
- 15 — VFD (Variable Frequency Drive)

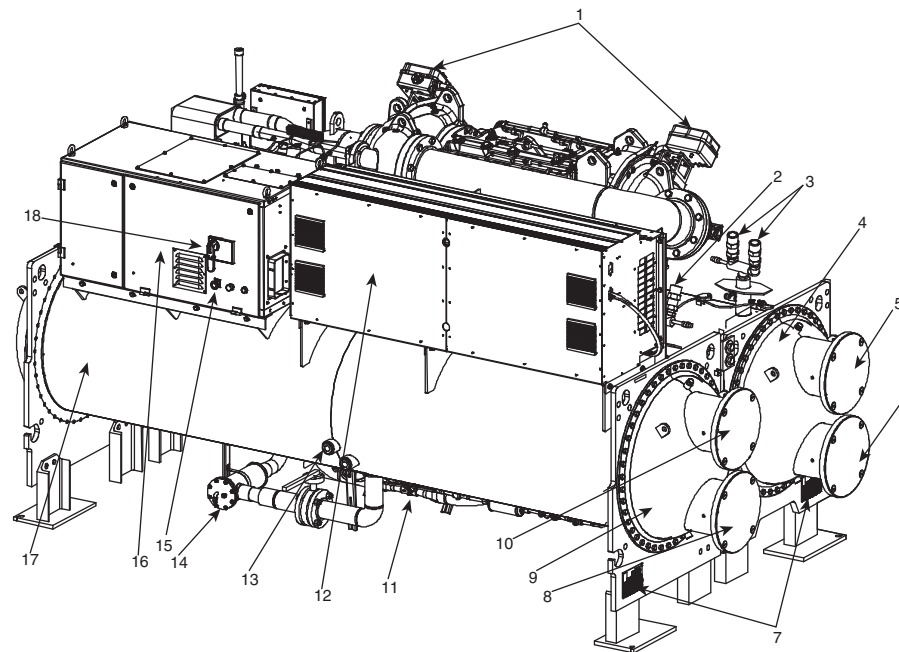

### LEGEND

- 1 — Dual Inlet Guide Vane Actuators
- 2 — Condenser Dual Relief Valves
- 3 — Evaporator Dual Relief Valves
- 4 — Evaporator Waterbox
- 5 — Leaving Evaporator Nozzle
- 6 — Entering Evaporator Nozzle
- 7 — ASME Nameplates
- 8 — Entering Condenser Nozzle
- 9 — Condenser Waterbox
- 10 — Leaving Condenser Nozzle
- 11 — Dual Electronic Expansion Valves
- 12 — VFD (Variable Frequency Drive)
- 13 — Condenser Sight Glasses
- 14 — Strainer
- 15 — E-stop
- 16 — Integrated Power and Control Panel
- 17 — Condenser
- 18 — Main Circuit Breaker

## 19MV Chiller Weight

The weight of a 19MV chiller is best obtained by running the chiller selection software. The 19MV has an extensive number of possible combinations of evaporators (including tubing type and length), condensers (including tubing type and length), waterbox types (taking into account heat exchanger passes), compressors, motors, and system accessories. The 19MV selection software will determine

the rigging weight, operating weight, corner weight, and spring deflection (if applicable) of any configured unit. Due to rigging and installation considerations, there are times when it becomes necessary to determine the contribution of individual components that comprise the chiller. For these situations, a detailed component breakdown is provided in the 19MV Installation Instructions.



# Options and accessories



ITEM	OPTION (FACTORY-INSTALLED)	ACCESSORY (FIELD-INSTALLED)
2 Pass Evaporator Water-side Construction	X	
2 Pass Condenser Water-side Construction	X	
Thermal Insulation (Except Waterbox Covers)	X	
Marine Waterboxes (150 psig (1034 kpa) <sup>a</sup>	X	
Flanged Evaporator and/or Condenser Waterbox Nozzles <sup>b</sup>	X	
Economizer Assembly (refrigerant circuit)	X	
0.025, 0.028, 0.035 in. (0.635, 0.711 or 0.889 mm) Internally, Externally Enhanced Copper Tubing – Evaporator	X	
0.025, 0.028, 0.035 in. (0.635, 0.711 or 0.889 mm) Internally, Externally Enhanced Copper Tubing – Condenser	X	
Customer Factory Performance Testing	X	
Extended Warranty (North America Only)	X	
BluEdge Service Agreement		X
BluEdge Digital		X
Soleplate Package		X
Spring Isolator		X
Multiple Chiller System Remote Temperature Sensor		X

NOTE(S):

- a. Optional marine waterboxes are available for 19MV, 2 pass only. Standard waterboxes for 19MV are nozzle-in-head type, 150 psig (1034 kPa).
- b. Standard waterbox nozzles are Victaulic type. Flanged nozzles are available as an option with either nozzle-in-head type waterboxes or marine waterboxes.

## Unit-Mounted VFD Features and Options<sup>a</sup>

ITEM	STANDARD (S) / OPTIONAL (O)
Microprocessor Based Overload Trip Protection	S
Main Power Fuse	S: 100kA
Phase Loss/Reversal Imbalance Protection	S
Three-Phase Ground Fault Protection	S
Three-Phase Over/Under Voltage Protection	S
Lightning Surge Arrestor (MOV)	O

NOTE(S):

- a. Low voltage: phase to phase and phase to ground.

## 19MV Recommended Clearances

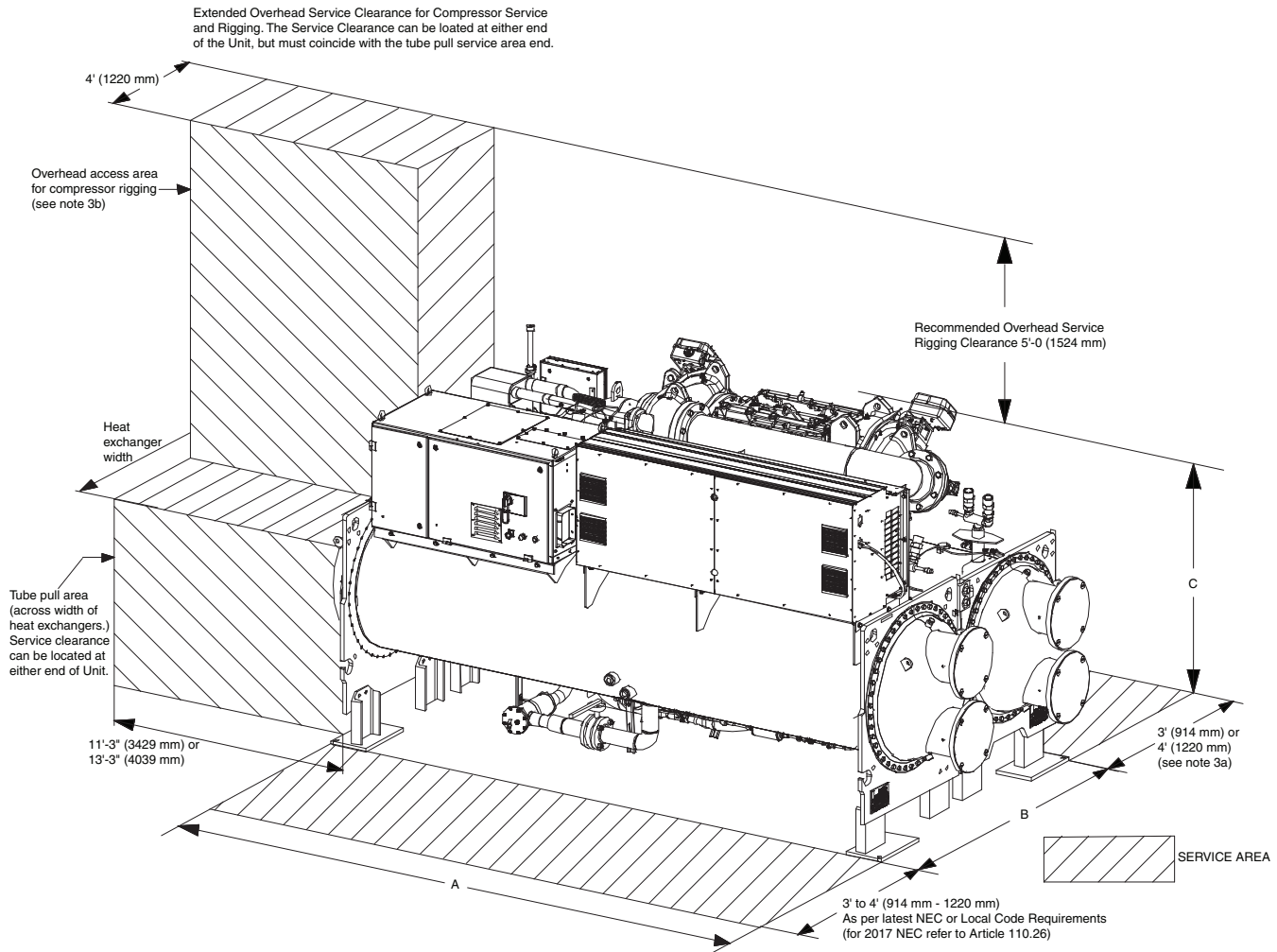

**LEGEND**

- A** — Length
- B** — Width
- C** — Height

**NOTES:**

1. Dished head (NIH) waterbox shown.
2. Service areas are minimum space required.
3. For compressor service either:
  - a. Allow 4' (1220 mm) on the evaporator side of the chiller.
  - b. Provide free space above the tube pull area equal to the height of chiller plus 5' (1524 mm). The overhead rigging space will allow the tube pull area to be utilized for service and must therefore coincide with the tube pull service area end.
4. For actual unit dimensions, contact your Carrier sales professional for certified drawings.

## Nozzle Size

FRAME SIZE	TYPE	DESIGN PRESSURE	PASSES	NOMINAL PIPE SIZE (in.)		ACTUAL PIPE ID (in.)	
				EVAPORATOR	CONDENSER	EVAPORATOR	CONDENSER
3	NIH	150	2	8	8	7.981	7.981
	MARINE						
4	NIH						
	MARINE						
5	NIH						
	MARINE						

# Selection procedure



The 19MV chiller can be tailored to the specific requirements of a given application. Please contact your local Carrier representative for a selection. The NG eCAT selection software analyzes many factors, including specific temperature, fluid type, and flow requirements to automatically configure the chiller's heat exchanger size, compressor aerodynamic model, and electrical sizing to deliver a chiller optimized to the job requirements.

## Heat exchangers

### Flow rate

If the evaporator flow is variable, the rate of change of flow should not exceed 30% per minute.

### Water quality

Please consult your local Carrier representative and/or a local water quality expert.

## Microprocessor controls

The microprocessor control system matches the capacity of the chiller to the cooling load while providing state-of-the-art chiller protection. The microprocessor-based control center protects the chiller by monitoring the digital and analog inputs and executing capacity overrides or safety shutdowns as necessary.

The system controls cooling load within the set point (plus or minus the dead band) by sensing the water or brine temperature and regulating the inlet guide vanes and regulating VFD speed.

## Features

### Control system

The control system on each 19MV centrifugal chiller is native BACnet, factory mounted, wired, and tested to ensure machine protection and efficient capacity control. In addition, the program logic ensures proper starting, stopping, and recycling of the chiller and seamlessly integrates with Carrier's i-Vu Building Automation Control System, supporting BACnet and Carrier Comfort Network (CCN) communication protocols. The PIC6 control system consists of one main control board and up to four IOBs (input/output board modules). All boards communicate via an internal LEN bus. The main control board is supplied from a 24 VAC supply reference to earth ground. In the event of a power supply interrupt, the unit can restart automatically without the need for an external command. However, any faults active when the supply is interrupted are saved, and may in certain cases prevent a circuit or unit

from restarting. IOBs are supplied from a 24 VAC supply reference to earth ground. Always separate communication cables from other cables and always run wiring as directly as possible.

## Sensors

### Pressure transducers

Pressure transducers measure and control the pressures in the unit. These electronic sensors deliver 0 to 5 VDC. The transducers can be calibrated through the controller. The pressure transducers are connected to the IOBs. See the Pressure Transducers table.

**Pressure Transducers**

PRESSURE	TRANSDUCER PURPOSE
Evaporator	Measures evaporator pressure
Condenser	Measures condenser pressure
Economizer	Measures economizer pressure

### Temperature sensors

The system uses electronic sensors to measure and control the temperatures in the unit. There are three types of temperature sensors: 5K thermistor, 10K thermistor, and RTD (resistance temperature detector), 100 ohm, 3-wire based on IOB channel configurations. The temperature sensor range is -40°F (-40°C) to 245°F (118°C). See the Temperature Sensors table.

**Temperature Sensors**

TEMPERATURE SENSOR	PURPOSE
Entering Chilled Water	Measure entering evaporator water temperature
Leaving Chilled Water	Measure leaving evaporator water temperature
Entering Condenser Water	Measure entering condenser water temperature
Leaving Condenser Water	Measure leaving condenser water temperature
Evaporator Refrigerant Liquid	Measure evaporator refrigerant liquid temperature
Compressor Discharge	Measure compressor discharge temperature
Radial Bearing Temp Sensor	Measure radial bearing temperature
Inboard Thrust Bearing Temp Sensor	Measure inboard thrust bearing temperature
Outboard Thrust Bearing Temp Sensor	Measure outboard thrust bearing temperature
Bearing Controller Temp Sensor	Measure bearing controller temperature
Motor Winding Temperature Sensors	Measure temperature of compressor motor windings

## Controls outputs

### Evaporator/condenser water pump

The controller can stop and start an evaporator/condenser water pump.

### Inlet guide vanes

The inlet guide vanes adjust the refrigerant vapor flow into the compressor to adapt to change in the operating conditions of the machine. To adjust the refrigerant flow, the guide vanes open or close to vary the cross-section of the refrigerant path. The high degree of accuracy with which the guide vanes are positioned ensures that the flow of refrigerant is precisely controlled.

### Expansion control system valve

The expansion control system valve is set in conjunction with dual EXVs to ensure smooth, proper operation as the chiller unloads across its operating profile.

### VFD

The VFD modifies motor voltage input and frequency to allow the chiller to react to changing lift conditions. Additionally, it allows compressor start-up and, along with inlet guide vanes, provides capacity control.

### Safety cutouts

- Guide vane calibration not completed
- Guide vane fault

- High bearing temperature
- High motor temperature
- High discharge temperature
- Low refrigerant temperature
- High evaporator pressure
- Under voltage
- Over voltage
- Intermittent power loss
- VFD configuration conflict
- High pressure switch
- Low liquid level
- Compressor starter faults
- Compressor surge protection
- Evaporator freeze protection
- Ground fault

## User interface and web connection

The PIC6 Human Machine Interface (HMI) is a color 10.4 in. TFT touch screen. Navigation is either direct from the touch screen interface or by connecting to a web interface at the Ethernet IP port of the controller. The navigation menus are the same for both connection methods. To access the PIC6 user interface, enter the IP address of the unit in the address bar of your web browser. The IP address can be viewed or changed from the PIC6 interface.

## 19MV Chiller with Unit-Mounted VFD Diagram

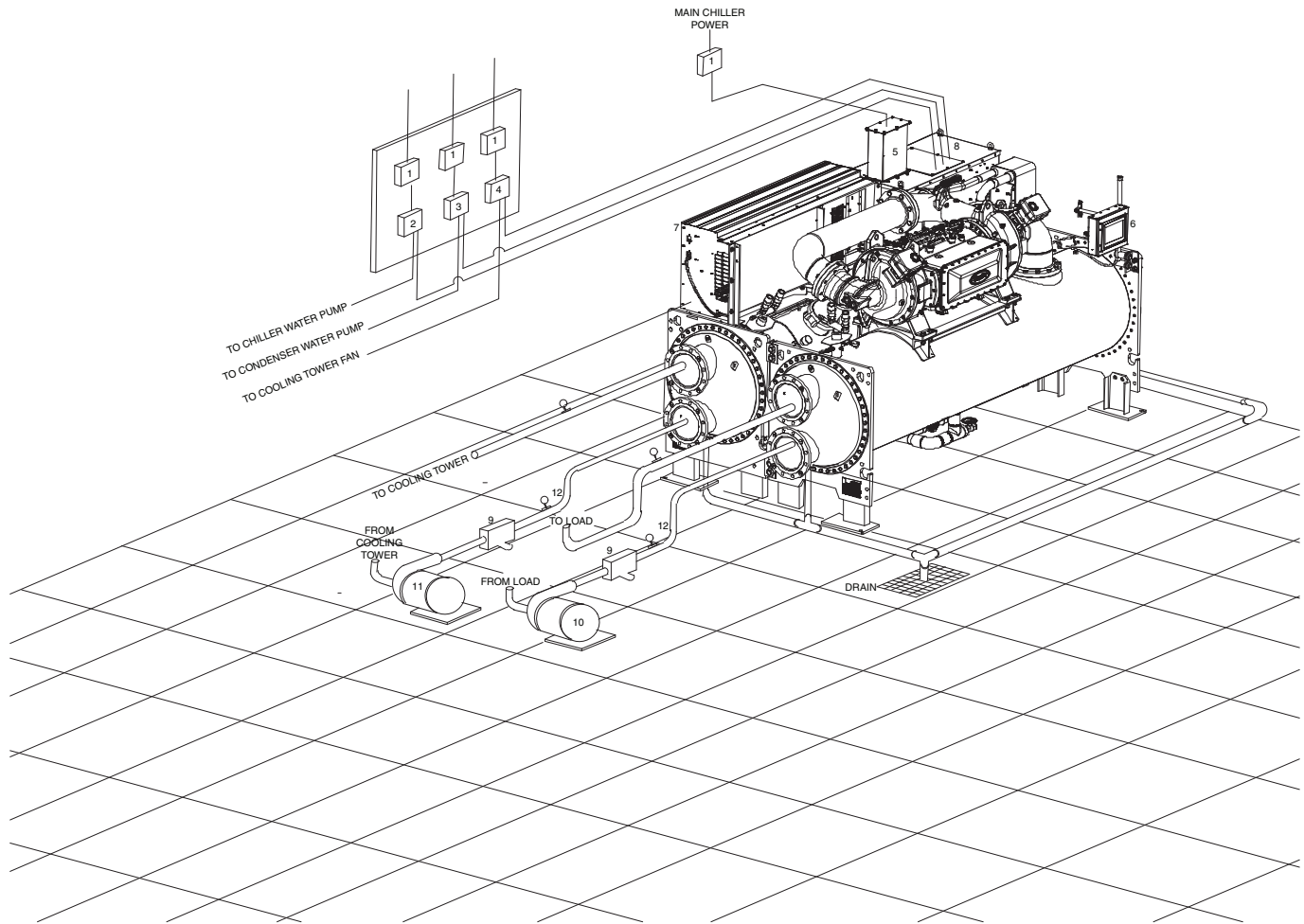

### LEGEND

- 1 — Disconnect
  - 2 — Chilled Water Pump Starter
  - 3 — Condenser Water Pump Starter
  - 4 — Cooling Tower Fan Starter (Low Fan, High Fan)
  - 5 — Tophat
  - 6 — HMI
  - 7 — Unit-Mounted VFD
  - 8 — Power Panel
  - 9 — Strainers
  - 10 — Chilled Water Pump
  - 11 — Condenser Water Pump
  - 12 — Pressure Gauges
  - 13 — Local Disconnect (hidden - in power panel)
- Piping  
 Control Wiring  
 Power Wiring

### NOTES:

1. Wiring and piping shown are for general point-of-connection only and are not intended to show details for a specific installation. Certified field wiring and dimensional diagrams are available on request.
2. All wiring must comply with applicable codes.
3. Wiring not shown for optional devices such as:
  - Remote Start/Stop
  - Remote Alarms
  - Optional Safety Device
  - 4 to 20 mA Resets
  - Optional Remote Sensors
4. **IMPORTANT:** Carrier suggests that a structural engineer be consulted if transmission of vibrations from mechanical equipment is of concern.
5. Isolation valves are recommended on the evaporator and condenser water piping to each chiller for service.
6. Operating environment — Chiller should be installed in an indoor environment where the ambient temperature is 40 to 104°F (4 to 40°C) with a relative humidity (non-condensing) of 95% or less. To ensure that electrical components operate properly, do not locate the chiller in an area exposed to dust, dirt, corrosive fumes, or excessive heat and humidity.
7. Disconnection must be incorporated in the fixed wiring in accordance with the local country-specific requirements or NFPA (National Fire Protection Association).
8. Tophat is shipped loose and field assembled.
9. Strainers are typically located on the suction side of the water pumps. It is acceptable to install strainers on either side of the pump.

## 19MV Two-Stage Compressor Machine Footprint

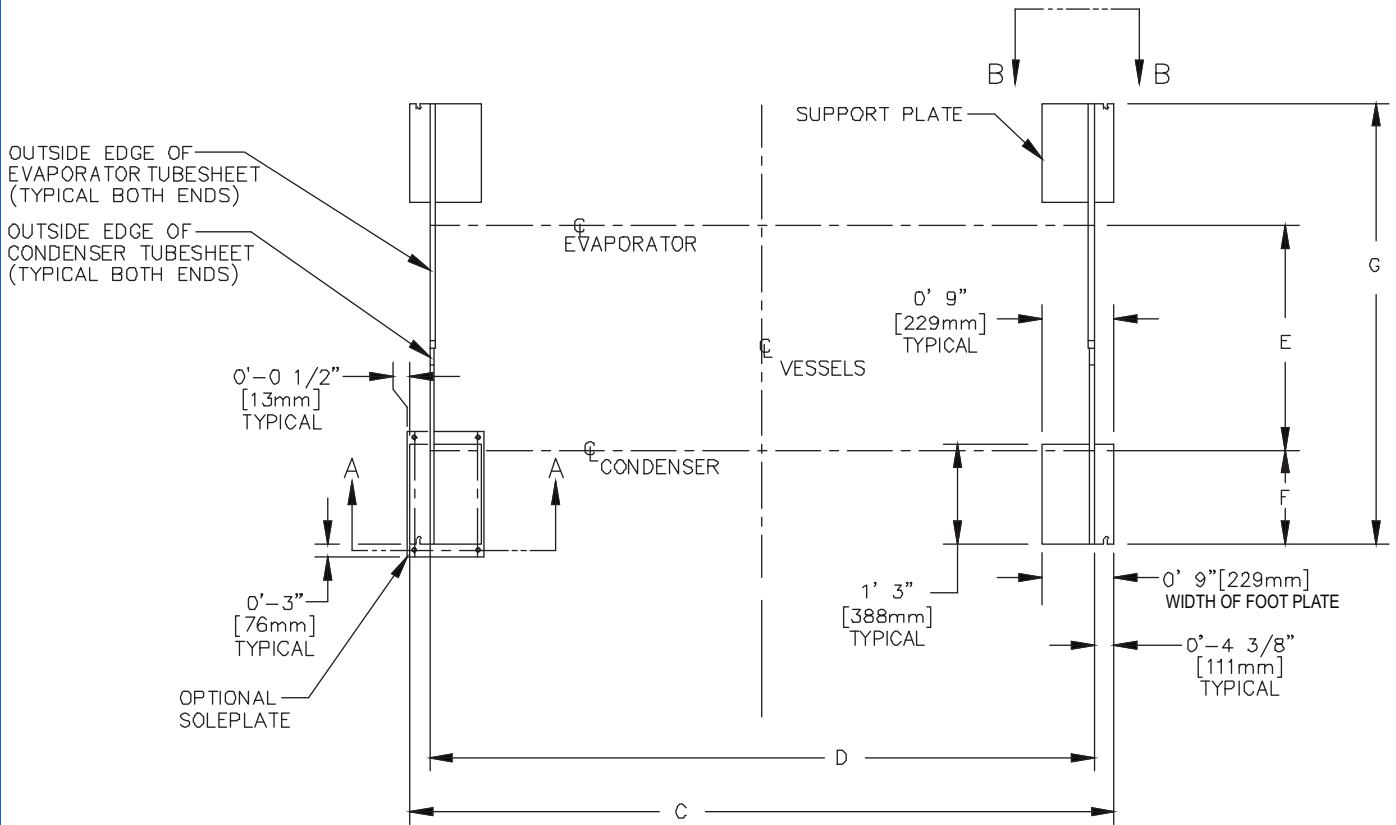

19MV HEAT EXCHANGER SIZE

FRAME	DIMENSION C		DIMENSION D		DIMENSION E		DIMENSION F		DIMENSION G	
	ft-in.	mm	ft-in.	mm	ft-in.	mm	ft-in.	mm	ft-in.	mm
3	11'-9 1/4"	3588	11'-2"	3404	2'-11"	889	1'-5 1/8"	435	5'-10"	1778
	13'-9 1/4"	4198	13'-2"	4013	2'-11"	889	1'-5 1/8"	435	5'-10"	1778
4	11'-9 1/4"	3588	11'-2"	3404	2'-11"	889	1'-4 3/4"	425	5'-10"	1778
	13'-9 1/4"	4198	13'-2"	4013	2'-11"	889	1'-4 3/4"	425	5'-10"	1778
5	11'-9 1/4"	3588	11'-2"	3404	3'-3 1/4"	997	1'- 8"	997	6'-6 1/2"	1994
	13'-9 1/4"	4198	13'-2"	4013	3'-3 1/4"	997	1'- 8"	997	6'-6 1/2"	1994

**NOTES:**

1. A-A view refers to accessory soleplate. See page 16.
2. B-B view refers to standard support plate. See page 16.
3. C dimension is measured from actual edge of footplate.
4. D dimension is measured from outside edge to outside edge of tubesheets.
5. E dimension is measured from center line to center line.
6. F dimension is measured from edge of tubesheets (extends past footplate). See certified drawings for actual maximum width.
7. G dimensions are from outermost edge of tubesheets (tubesheet extends slightly past footplate).

## 19MV Isolation with Accessory Soleplate Package

**TYPICAL ISOLATION**

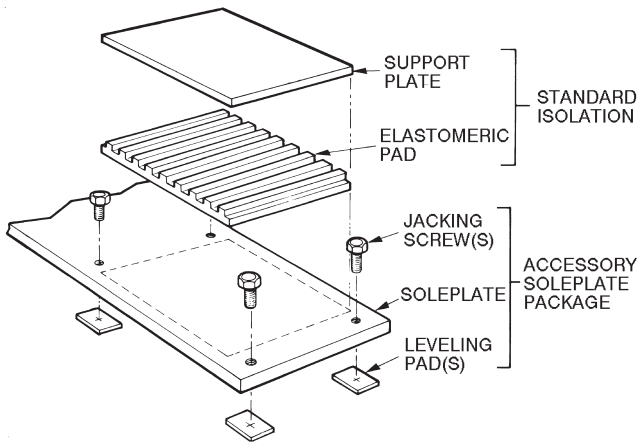

**STANDARD ISOLATION**

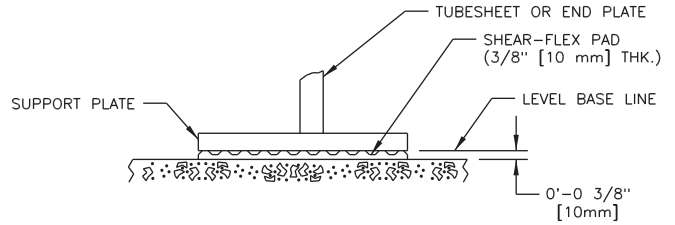

**VIEW B-B**

**ISOLATION WITH STANDARD PACKAGE ONLY**

NOTE: Isolation package includes 4 Shear-Flex isolation pads.

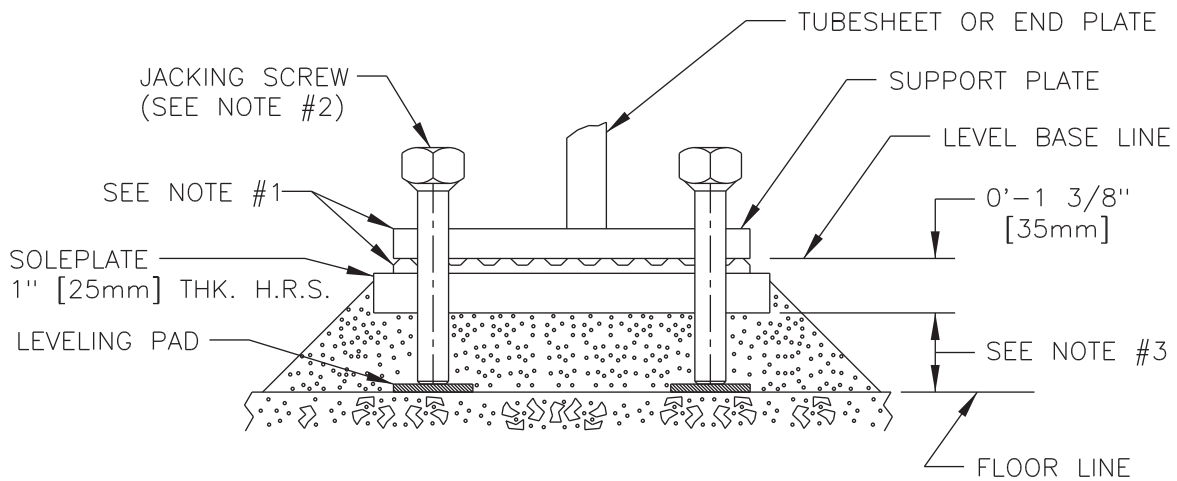

**VIEW A-A**

**NOTES:**

1. Optional soleplate package includes 4 soleplates, 16 jacking screws, and 16 leveling pads. Isolation package is also required.
2. Jacking screws to be removed after grout has set.
3. Thickness of grout will vary, depending on the amount necessary to level chiller. Use Ceilcote<sup>1</sup> 748 OR MasterFlow<sup>1</sup> 885, 0'-1-1/2" (38.1 mm) to 0'-2-1/4" (57 mm) thick. Both grouts have minimum shrinkage. MasterFlow is premixed.

1. Third-party trademarks and logos are the property of their respective owners.



## 19MV Nozzle Arrangements Nozzle-in-Head Waterboxes

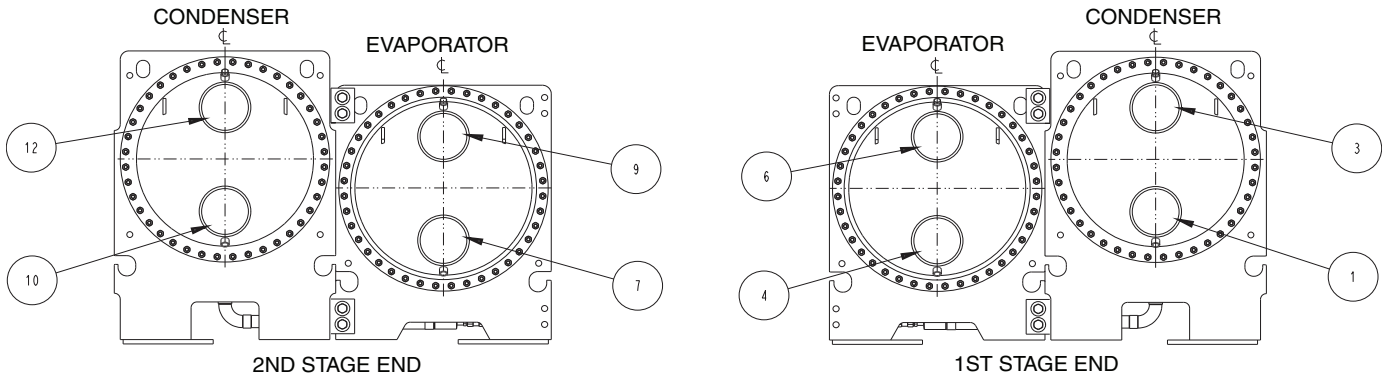

### NOZZLE ARRANGEMENT CODES FOR NOZZLE-IN-HEAD WATERBOXES

EVAPORATOR WATERBOXES <sup>a</sup>			
PASS	In	Out	Arrangement Code <sup>b</sup>
2	7	9	C
	4	6	D

CONDENSER WATERBOXES <sup>a</sup>			
PASS	In	Out	Arrangement Code <sup>b</sup>
2	10	12	R
	1	3	S

NOTE(S):

- a. Vents and drains are 3/4 in., FPT, located on waterbox head.
- b. Refer to certified drawings.

## 19MV Nozzle Arrangements Marine Waterboxes

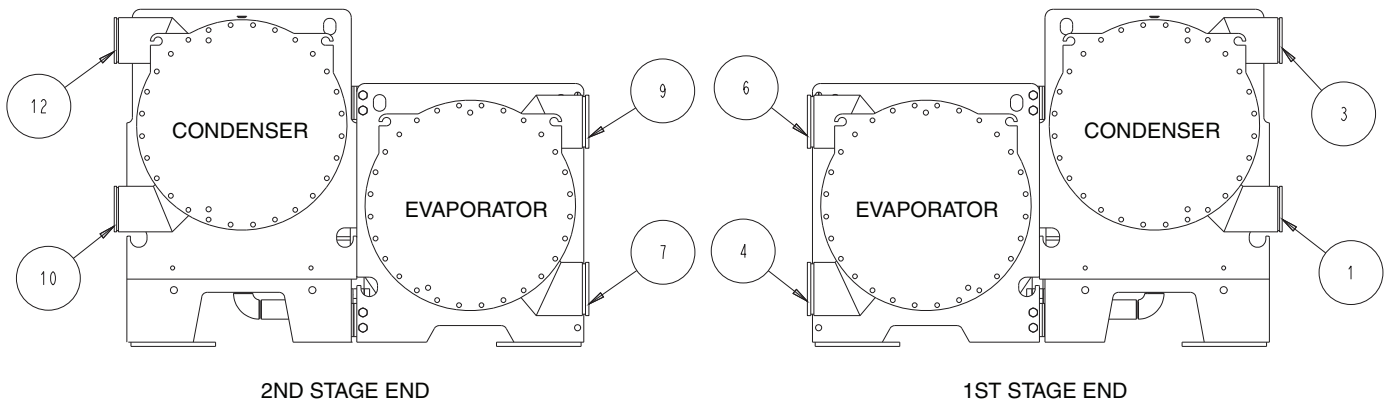

### NOZZLE ARRANGEMENT CODES FOR MARINE WATERBOXES

EVAPORATOR WATERBOXES <sup>a</sup>			
PASS	In	Out	Arrangement Code <sup>b</sup>
2	7	9	C
	4	6	D

CONDENSER WATERBOXES <sup>a</sup>			
PASS	In	Out	Arrangement Code <sup>b</sup>
2	10	12	R
	1	3	S

NOTE(S):

- a. Vents and drains are 3/4 in., FPT, located on waterbox head.
- b. Refer to certified drawings.

## Relief Valve Locations<sup>a</sup>

LOCATION	FRAME SIZE	PRESSURE RELIEF DEVICE OUTLET SIZE
EVAPORATOR	3, 4, 5	2X 1-1/4 in. NPT FEMALE CONNECTOR (installed with transfer valve)
CONDENSER		2X 1-1/4 in. NPT FEMALE CONNECTOR (installed with transfer valve)

NOTE(S):

a. All valves relieve at 185 psig (1275 kPa).

## Relief Device Arrangements

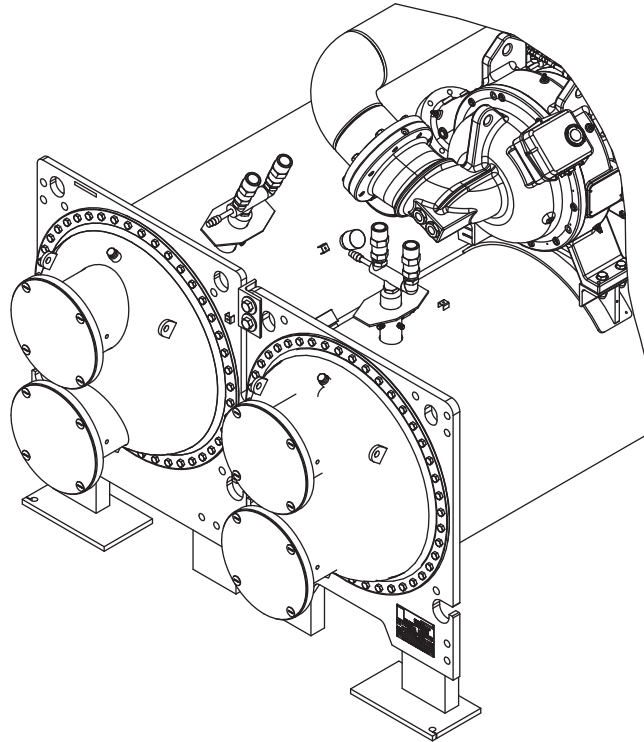

## Vent and drain connections

Nozzle-in-head waterboxes have vent and drain connections on covers. Marine waterboxes have vent and drain connections on waterbox shells.

Provide high points of the chiller piping system with vents and the low points with drains. If shutoff valves are provided in the main water pipes near the unit, a minimal amount of system water is lost when the heat exchangers are drained. This reduces the time required for drainage and saves on the cost of re-treating the system water.

It is recommended that pressure gauges be provided at points of entering and leaving water to measure pressure drop through the heat exchanger. Gauges may be installed as shown in Pressure Gauge Location table. Pressure gauges installed at the vent and drain connections do not include nozzle pressure losses.

Use a reliable differential pressure gauge to measure pressure differential when determining water flow. Regular gauges of the required pressure range do not have the accuracy to provide accurate measurement of flow conditions.

### Pressure Gauge Location

NUMBER OF PASSES	GAUGE LOCATION (EVAPORATOR OR CONDENSER)
2	Two gauges in waterbox with nozzles

## ASME stamping

All 19MV heat exchangers are constructed in accordance with ASHRAE (American Society of Heating, Refrigerating, and Air-Conditioning Engineers) 15 Safety Code for Mechanical Refrigeration (latest edition). This code, in turn, requires conformance with ASME (American Society of Mechanical Engineers) Code for Unfired Pressure Vessels wherever applicable.

Each vessel is constructed and certified in accordance with ASME Section 8, Division 1.

## Relief valve discharge pipe sizing

See page 18 for number of relief valves and locations.

Relief-valve discharge piping size should be calculated per ASHRAE 15, latest edition, using the tabulated C factors for each vessel shown in the Rupture Disc Discharge Pipe Sizing table.

Carrier further recommends that an oxygen sensor be installed to protect personnel. Sensor should be able to sense the depletion or displacement of oxygen in the machine room below 19.5% volume oxygen per ASHRAE 15, latest edition.

### Relief Valve Discharge Pipe Sizing

HEAT EXCHANGER	FRAME SIZE	REQUIRED C FACTOR [LBM AIR / MIN]	RATED C FACTOR [LBM AIR / MIN]	FIELD CONNECTION SIZE [FPT], in.
EVAPORATOR	31B to 31N	39.5	70.8	1-1/4
	33B to 33N	46.5	70.8	1-1/4
	41B to 41N	45.8	70.8	1-1/4
	43B to 43N	54.0	70.8	1-1/4
	51B to 51N	48.8	70.8	1-1/4
	53B to 53N	57.5	70.8	1-1/4
	31O to 31Z	39.5	70.8	1-1/4
	33O to 33Z	46.5	70.8	1-1/4
	41O to 41Z	45.8	70.8	1-1/4
	43O to 43Z	54.0	70.8	1-1/4
CONDENSER	51O to 51Z	48.8	70.8	1-1/4
	53O to 53Z	57.5	70.8	1-1/4
	31B to 31N	37.6	70.8	1-1/4
	33B to 33N	44.3	70.8	1-1/4
	41B to 41N	42.8	70.8	1-1/4
	43B to 43N	50.5	70.8	1-1/4
	51B to 51N	46.5	70.8	1-1/4
	53B to 53N	54.9	70.8	1-1/4

## Design pressures

Design and test pressures for heat exchangers are listed below.

### Design and Test Pressures for Heat Exchangers

VESSEL PRESSURES		SHELL SIDE (REFRIGERANT)		STANDARD TUBE SIDE (WATER)		OPTIONAL TUBE SIDE (WATER)	
		psig	kPa	psig	kPa	psig	kPa
EVAPORATOR	Design	185	1276	150	1034	300	2068
	Leak Test (min)	185	1276	150	1034	300	2068
	Hydrostatic Test	—	—	195	1344	390	2690
	Proof Test (min Pneumatic)	204	1407	—	—	—	—
CONDENSER	Design	185	1276	150	1034	300	2068
	Leak Test (min)	185	1276	150	1034	300	2068
	Hydrostatic Test	—	—	195	1344	390	2690
	Proof Test (min Pneumatic)	204	1407	—	—	—	—
ECONOMIZER	Design	185	1276	—	—	—	—
	Leak Test (min)	185	1276	—	—	—	—
	Hydrostatic Test	—	—	—	—	—	—
	Proof Test (min Pneumatic)	204	1407	—	—	—	—

### Heat Exchanger Material Specifications

ITEM	MATERIAL	SPECIFICATION
SHELL	HR Steel	ASME SA516 GR .70
TUBE SHEET	HR Steel	ASME SA516 GR .70
FLAT COVERS	HR Steel	ASME/ASTM A516 GR.70
PIPE	Steel	ASME SA106 GRB/SA53 E/B
FLANGES	Steel	ASME B16.5
TUBES	Per Job Requirement	ASME SB359
DISHED COVER	HR Steel	ASTM A516 GR.70/GB713 Q345R
MARINE WATER BOX SHELL	HR Steel	ASME/ASTM A516 GR.70

## Insulation

### Factory insulation (optional)

The factory insulation option for the 19MV chillers include the following areas: evaporator (not including waterbox); suction line up to the compressor suction housing; compressor motor and motor cooling return lines; the liquid line, economizer and economizer piping.

Insulation applied at the factory is 3/4 in. (19 mm) thick and has a thermal conductivity K value of 0.28 (Btu in.)/hr ft<sup>2</sup> °F [(0.0404 • W)/(m • °C)]. Insulation conforms with Underwriters Laboratories (UL) Standard 94, Classification 94HBF.

### Insulation at jobsite

As indicated in the Condensation vs. Relative Humidity table, the factory insulation provides excellent protection against condensation under most operating conditions. If temperatures in the equipment area exceed the maximum design conditions, extra insulation is recommended. If the machine is to be field insulated, obtain the approximate areas from the Minimum Field-Installed Insulation Requirements table.

Insulation of waterbox is made only in the field and this area is not included in Minimum Field-Installed Insulation Requirements table. When insulating the covers, allow for service access and removal of covers. To estimate waterbox cover areas refer to certified drawings.

High humidity jobsite locations may require field supplied and installed insulation on the suction housing and lower half of the condenser.

### Minimum Field-installed Insulation Requirements<sup>a,b</sup>

FRAME SIZE	LENGTH (in.)	INSULATION AREA (sq ft)
Frame 3	134	125
Frame 3	158	135
Frame 4	134	155
Frame 4	158	170
Frame 5	134	170
Frame 5	158	185

NOTE(S):

- Factory installed as shown on page 21.
- Insulation amount includes only the amount of insulation required to insulate the sections of the chiller that would be included in the factory-installed insulation option.

### Condensation vs. Relative Humidity<sup>a</sup>

AMOUNT OF CONDENSATION	ROOM DRY-BULB TEMP		
	80°F (27°C)	90°F (32°C)	100°F (38°C)
	% RELATIVE HUMIDITY		
NONE	80	76	70
SLIGHT	87	84	77
EXTENSIVE	94	91	84

NOTE(S):

- These approximate figures are based on 35°F (1.7°C) saturated suction temperature. A 2°F (1.1°C) change in saturated suction temperature changes the relative humidity values by 1% in the same direction.

## Unit location

Chiller should be installed in an indoor environment where the ambient temperature is 40 to 104°F (4 to 40°C) with a relative humidity (non-condensing) of 95% or less. To ensure that electrical components operate properly, do not locate the chiller in an area exposed to dust, dirt, corrosive fumes, or excessive heat and humidity.

## 19MV Standard Insulation Area

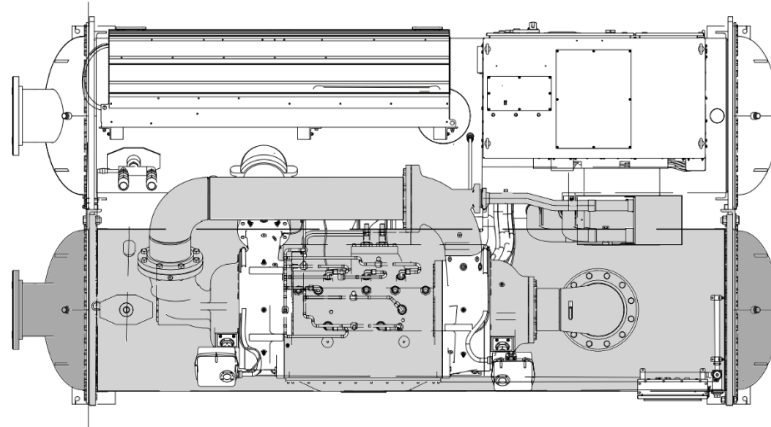

TOP

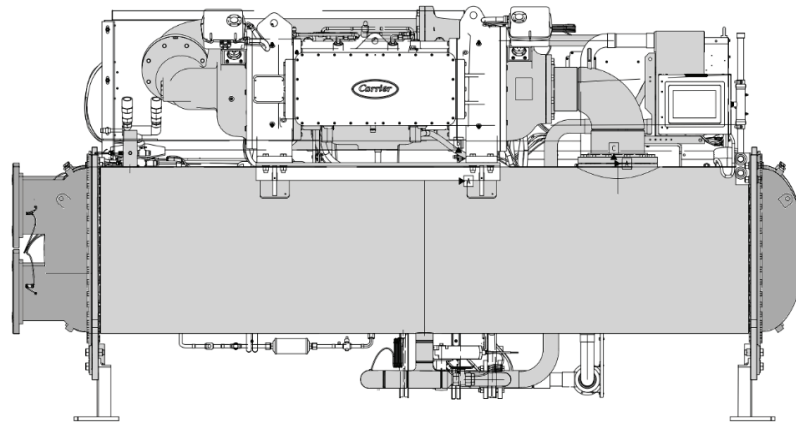

2ND STAGE

FRONT

1ST STAGE

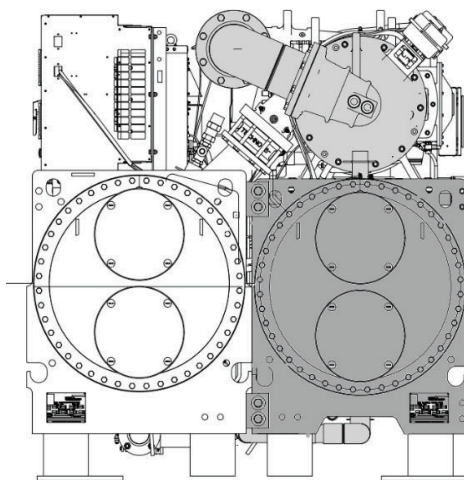

2ND STAGE END

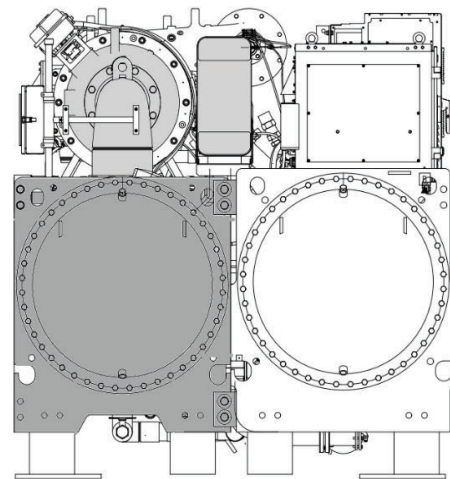

1ST STAGE END

Economized configuration optional, and shown here as reference.

 FACTORY INSTALLED

 FIELD SUPPLIED AND INSTALLED

Note about this specification:  
This specification is in the "Masterformat" as published by the Construction Specification Institute. Please feel free to copy this specification directly into your building spec.

## Packaged Semi-Hermetic Centrifugal Liquid Chiller

### HVAC Guide Specifications — 19MV

Size Range: **19MV to 300 to 700 Nominal Tons (1,055 to 2,461 kW)**

Carrier Model Number: **19MV**

#### Part 1 — General

##### 1.01 SYSTEM DESCRIPTION

- A. Microprocessor-controlled liquid chiller shall use a semi-hermetic centrifugal compressor using refrigerant R-515B, R-513A, or R-134a.
- B. If a manufacturer proposes a liquid chiller using HCFC-123 or HFC/HFO-514A refrigerant, then the manufacturer shall include in the chiller price:
  1. A vapor activated alarm system shall be capable of responding to HCFC-123 or HFC/HFO-514A levels of 10 ppm Allowable Exposure Limit (AEL).
  2. External refrigerant storage tank and pumpout unit.
  3. Zero emission purge unit capable of operating even when the chiller is not operating.
  4. Back-up relief valve to rupture disk.
  5. Chiller pressurizing system to prevent leakage of noncondensables into chiller during shut-down periods.
  6. Plant room ventilation.

##### 1.02 QUALITY ASSURANCE

- A. Chiller performance shall be rated in accordance with AHRI (Air-Conditioning, Heating and Refrigeration Institute) Standard 550/590, latest edition. The chiller manufacturer, model number and refrigerant shall be listed on the AHRI.org website ([www.ahridirectory.org](http://www.ahridirectory.org)).
- B. Equipment and installation shall be in compliance with ANSI/ASHRAE (American National Standards Institute/American Society of Heating, Refrigerating and Air-Conditioning Engineers) 15 (latest edition).
- C. Evaporator and condenser refrigerant side shall include ASME "U" stamp and nameplate certifying compliance with ASME Section VIII, Division 1 code for unfired pressure vessels.
- D. Chiller shall be designed and constructed to meet UL (Underwriters Laboratories) and UL, Canada requirements and have labels appropriately affixed.
- E. Centrifugal compressor impellers shall be dynamically balanced and over-speed tested by the manufacturer at a minimum of 120% design operating speed. Each compressor assembly shall undergo a mechanical run-in test to verify vibration levels are within acceptable limits.

- F. Each compressor assembly shall be proof tested at a minimum 204 psig (1406 kPa) and leak tested at 185 psig (1276 kPa) with a tracer gas mixture.
- G. Entire chiller assembly shall be proof tested at 204 psig (1406 kPa) and leak tested at 185 psig (1276 kPa) with a tracer gas mixture on the refrigerant side. The water side of each heat exchanger shall be hydrostatically tested at 1.3 times rated working pressure.
- H. Prior to shipment, the chiller automated controls test shall be executed to check for proper wiring and ensure correct controls operation.
  - I. The chiller and VFD (variable frequency drive) shall be factory wired and tested together to verify proper operation prior to shipment.
  - J. The management system governing the manufacture of this chiller shall be ISO 9001:2015 certified.

##### 1.03 DELIVERY, STORAGE AND HANDLING

- A. Unit shall be stored and handled in accordance with manufacturer's instructions.
- B. Unit shall be shipped with all refrigerant piping and control wiring factory installed.
- C. Unit shall be shipped charged with full charge of refrigerant R-515B, R-513A, or R-134a, or a nitrogen holding charge as specified on the equipment schedule.
- D. Unit shall be shipped with firmly attached labels that indicate name of manufacturer, chiller model number, chiller serial number, and refrigerant used.
- E. If the chiller is to be exported, the unit shall be sufficiently protected from the factory against sea water corrosion to be suitable for shipment in a standard open top, ocean shipping container (19MV heat exchanger frames 3 through 4 only).

##### 1.04 WARRANTY

Warranty shall include parts and labor for one year after start-up or 18 months from shipment, whichever occurs first.

#### Part 2 — Products

##### 2.01 EQUIPMENT

- A. General: Factory assembled, single piece, liquid chiller shall consist of compressor, motor, variable frequency drive, evaporator, condenser, refrigerant operating charge, microprocessor control system, and documentation required prior to start-up. The compressor VFD will be wired and tested by the chiller manufacturer (select models).
- B. Compressor:
  1. The compressor-motor assembly shall be direct drive semi-hermetic centrifugal with multi-stage design with magnetic bearings. Centrifugal compressors shall use variable inlet guide vanes to provide partial capacity modulation while also providing pre-whirl of the refrigerant vapor entering the impeller.

2. Chiller shall be able to unload to 10% of design tonnage at design temperatures and flows without gas flow recirculation, load balance valve, or hot gas bypass.
3. Compressor shall be fully field serviceable. Compressors which must be removed and returned to the factory for service shall be unacceptable.

## C. Motor:

1. Compressor motor shall be of the semi-hermetic, liquid refrigerant cooled, permanent magnet type suitable for voltage shown on the equipment schedule.
2. If an open drive motor is provided, a compressor shaft seal leakage containment system shall be provided.
  - a. An oil reservoir shall collect oil and refrigerant that leaks past the seal.
  - b. A float device shall be provided to open when the reservoir is full, directing the refrigerant/oil mixture back into the compressor housing.
  - c. A refrigerant sensor shall be located next to the open drive seal to detect leaks.
3. Motors shall be suitable for operation in a refrigerant atmosphere and shall be cooled by atomized refrigerant in contact with the motor windings.
4. Motor stator shall be arranged for service or removal with only minor compressor disassembly and without removing main refrigerant piping connections.
5. Full load operation of the motor shall not exceed nameplate rating.
6. At least one motor winding temperature sensor (and one spare) shall be provided.
7. Should the mechanical contractor choose to provide a chiller with an open motor instead of the specified semi-hermetic motor, the contractor shall install additional cooling equipment to dissipate the motor heat as per the following formula:  
$$\text{Btuh} = (\text{FLkW motor}) (0.05) (3413)$$
$$\text{Btuh} = (\text{FLkW motor}) (171)$$
and, alternately,  
$$\text{Tons} = \text{Btuh} / 12,000$$
The additional piping, valves, air-handling equipment, insulation, wiring, switchgear changes, ductwork, and coordination with other trades shall be the responsibility of the mechanical contractor. Shop drawings reflecting any changes to the design shall be included in the submittal, and incorporated into the final as built drawings for the project.
8. Also, if an open motor is provided, a mechanical room thermostat shall be provided and set at 104°F (40°C). If this temperature is exceeded, the chillers shall shut down and an alarm signal shall be generated to the Central Energy Management System (EMS) display module prompting the service personnel to

diagnose and repair the cause of the over-temperature condition. The mechanical contractor shall be responsible for all changes to the design, including coordination with temperature control, electrical and other trades. In addition, the electrical power consumption of any auxiliary ventilation and/or mechanical cooling required to maintain the mechanical room conditions stated above shall be considered in the determination of conformance to the scheduled chiller energy efficiency requirement.

## D. Evaporator and Condenser:

1. Evaporator shall be of shell and tube type construction, each in separate shells. Units shall be fabricated with high-performance tubing, minimum 1/4 in. (6 mm) steel shell and tube sheets with fabricated steel waterboxes.
  - a. Waterbox shall be nozzle-in-head waterbox (150 psig [1034 kPa]).
  - b. Waterbox shall have standard Victaulic grooves. Victaulic AGS grooves shall be provided for nominal 14 in. pipe and larger.
2. Condenser shall be of shell and tube type construction, each in separate shells. Units shall be fabricated with high-performance tubing, minimum 1/4 in. (6 mm) steel shell and tube sheets with fabricated steel waterboxes.
  - a. Waterbox shall be nozzle-in-head (150 psig [1034 kPa]).
  - b. Waterbox shall have standard Victaulic grooves. Victaulic AGS grooves shall be provided for nominal 14 in. pipe and larger.
3. Waterboxes shall have vents, drains, and covers to permit tube cleaning within the space shown on the drawings. A thermistor type temperature sensor with quick connects shall be factory installed in each water nozzle.
4. Tubes shall be individually replaceable from either end of the heat exchanger without affecting the strength and durability of the tube sheet and without causing leakage in adjacent tubes.
5. Tubing shall be copper, high-efficiency type, with integral internal and external enhancement unless otherwise noted. Tubes shall be nominal 3/4 in. or 1 in. OD with nominal wall thickness of 0.025 in. measured at the root of the fin at the enhanced areas unless otherwise noted. Tubes shall be rolled into tube sheets and shall be individually replaceable. Tube sheet holes shall be double grooved for joint structural integrity.
6. Evaporator shall be designed to prevent liquid refrigerant from entering the compressor.
7. The condenser shell shall include a subcooler which cools the condensed liquid refrigerant to a reduced temperature, thereby increasing the refrigeration cycle efficiency.
8. A reseating type pressure relief valve shall be installed on each heat exchanger. If a

non-reseating type is used, a backup reseating type shall be installed in series.

## E. Refrigerant Flow Control:

1. To maintain optimal part load efficiency at high or low lift, the chiller shall utilize (2) Electronic Expansion Valves (EXVs) in the liquid line between the condenser and the evaporator. When equipped, the economizer, shall use a variable metering valve. To ensure good operating performance, the valve design will prevent refrigerant gas from the condenser from passing to the evaporator or economizer at full or part load.
2. By maintaining a liquid seal at the flow valve, bypassed hot gas from the condenser to the evaporator is eliminated.

## F. Controls, Safeties, and Diagnostics:

### 1. Controls:

- a. The chiller shall be provided with a factory installed and wired microprocessor control center. The microprocessor can be configured for either English or SI units.
- b. All chiller and starter monitoring shall be displayed at the chiller control panel.
- c. The controls shall make use of non-volatile memory.
- d. The chiller control system shall have the ability to interface and communicate directly to the building control system.
- e. The default standard display screen shall simultaneously indicate the following minimum information:
  - 1) date and time of day
  - 2) 24-character primary system status message
  - 3) 24-character secondary status message
  - 4) chiller operating hours
  - 5) entering chilled water temperature
  - 6) leaving chilled water temperature
  - 7) evaporator refrigerant temperature
  - 8) entering condenser water temperature
  - 9) leaving condenser water temperature
  - 10) condenser refrigerant temperature
  - 11) percent motor rated load amps (RLA)
- f. In addition to the default screen, status screens shall be accessible to view the status of every point monitored by the control center including:
  - 1) evaporator pressure
  - 2) condenser pressure
  - 3) compressor discharge temperature
  - 4) motor winding temperature
  - 5) number of compressor starts
  - 6) control point settings
  - 7) discrete output status of various devices

8) compressor motor starter status

9) optional spare input channels

### g. Schedule Function:

The chiller controls shall be configurable for manual or automatic start-up and shutdown. In automatic operation mode, the controls shall be capable of automatically starting and stopping the chiller according to a stored user programmable occupancy schedule. The controls shall include built-in provisions for accepting:

- 1) A minimum of two 365-day occupancy schedules.
- 2) Minimum of 8 separate occupied/unoccupied periods per day.
- 3) Daylight savings start/end.
- 4) Minimum of 18 user-defined holidays.
- 5) Means of configuring an occupancy timed override.
- 6) Chiller start-up and shutdown via remote contact closure.

### h. Service Function:

The controls shall provide a password protected service function which allows authorized individuals to view an alarm history file which shall contain the last 25 alarm/alert messages with time and date stamp. These messages shall be displayed in text form, not codes.

### i. Network Window Function:

Each chiller control panel shall be capable of viewing multiple point values and statuses from other like controllers connected on a common network, including controller maintenance data. The operator shall be able to alter the remote controller's set points or time schedule and to force point values or statuses for those points that are operator forcible. The control panel shall also have access to the alarm history file of all like controllers connected on the network.

### j. Pump Control:

Upon request to start the compressor, the control system shall start the chilled water pump, condenser water pumps and verify that flows have been established.

### k. Ramp Loading:

A user-configurable ramp loading rate, effective during the chilled water temperature pulldown period, shall control the rate of guide vane opening to prevent a rapid increase in compressor power consumption. The controls shall allow configuration of the ramp loading rate in either degrees/minute of chilled water temperature pulldown or percent motor amps/minute. During the ramp loading period, a message shall be



displayed informing the operator that the chiller is operating in ramp loading mode.

- l. Chilled Water Reset:

The control center shall allow reset of the chilled water temperature set point based on any one of the following criteria:

    - 1) Chilled water reset based on an external 4 to 20 mA signal.
    - 2) Chilled water reset based on a remote temperature sensor (such as outdoor air).
    - 3) Chilled water reset based on water temperature rise across the evaporator.
  - m. Demand Limit:

The control center shall limit amp draw of the compressor to the rated load amps or to a lower value based on one of the following criteria:

    - 1) Demand limit based on a user input ranging from 40% to 100% of compressor rated load amps.
    - 2) Demand limit based on external 4 to 20 mA signal.
  - n. Controlled Compressor Shutdown:

The controls shall be capable of being configured to soft stop the compressor. When the stop button is pressed or remote contacts open with this feature active, the guide vanes shall close to a configured amperage level and the machine shall then shut down. The display shall indicate "shutdown in progress."
2. Safeties:
    - a. Unit shall automatically shut down when any of the following conditions occur: (Each of these protective limits shall require manual reset and cause an alarm message to be displayed on the control panel screen, informing the operator of the shutdown cause.)
      - 1) motor overcurrent
      - 2) over voltage\*
      - 3) under voltage\*
      - 4) single cycle dropout\*
      - 5) high condenser pressure
      - 6) high motor temperature
      - 7) high compressor discharge temperature
      - 8) prolonged surge
      - 9) loss of evaporator water flow
      - 10) loss of condenser water flow
      - 11) starter fault

\* Shall not require manual reset or cause an alarm if auto-restart after power failure is enabled.
    - b. The control system shall detect conditions that approach protective limits and take self corrective action prior to an alarm occurring. The system shall automatically reduce chiller capacity when any of the following parameters are outside their normal operating range:
      - 1) high condenser pressure
      - 2) high motor temperature
      - 3) low evaporator refrigerant temperature
      - 4) surge prevention control
      - 5) high motor amps.
    - c. During the capacity override period, a pre-alarm (alert) message shall be displayed informing the operator which condition is causing the capacity override. Once the condition is again within acceptable limits, the override condition shall be terminated and the chiller shall revert to normal chilled water control. If during either condition the protective limit is reached, the chiller shall shut down and a message shall be displayed informing the operator which condition caused the shutdown and alarm.
    - d. Internal built-in safeties shall protect the chiller from loss of water flow. Differential pressure switches shall not be allowed to be the only form of freeze protection.
  3. Diagnostics and Service:
    - a. A self diagnostic controls test shall be an integral part of the control system to allow quick identification of malfunctioning components.
    - b. Once the controls test has been initiated, all pressure and temperature sensors shall be checked to ensure they are within normal operating range. A pump test shall automatically energize the chilled water pump and condenser water pump. The control system shall confirm that water flow has been established and require operator confirmation before proceeding to the next test. A guide vane actuator test shall open and close the guide vanes to check for proper operation. The operator manually acknowledges proper guide vane operation prior to proceeding to the next test.
    - c. In addition to the automated controls test, the controls shall provide a manual test which permits selection and testing of individual control components and inputs. A thermistor test and transducer test shall display and an actual reading shall be performed for each transducer and each thermistor installed on the chiller. All out-of-range sensors shall be identified.

## 4. Multiple Chiller Control:

The chiller controls shall be supplied as standard with a two-chiller lead/lag and a third chiller standby system. The control system shall automatically start and stop a lag or second chiller on a two-chiller system. If one of the two chillers on line goes into a fault mode, the third standby chiller shall be automatically started.

The two-chiller lead/lag system shall allow manual rotation of the lead chiller, include load balancing if configured, and a staggered restart of the chillers after a power failure.

## G. Electrical Requirements:

1. Electrical contractor shall supply and install main electrical power line, disconnect switches, circuit breakers, and electrical protection devices per local code requirements and as indicated necessary by the chiller manufacturer.
2. Electrical contractor shall wire the chilled water pump, condenser water pump, and tower fan control circuit to the chiller control circuit.
3. Electrical contractor shall supply and install electrical wiring and devices required to interface the chiller controls with the building control system if applicable.
4. Electrical power shall be supplied to the unit at the voltage, phase, and frequency listed in the equipment schedule.

## H. Piping Requirements — Instrumentation and Safeties:

- a. Mechanical contractor shall supply and install pressure gauges in readily accessible locations in piping adjacent to the chiller such that they can be easily read from a standing position on the floor. Scale range shall be such that design values shall be indicated at approximately midscale.
- b. Gauges shall be installed in the entering and leaving water lines of the evaporator and condenser.

## I. Isolator Pads:

Chiller manufacturer shall furnish neoprene isolator pads for mounting equipment on a level concrete surface.

## J. Start-up:

1. The chiller manufacturer shall provide a factory trained representative, employed by the chiller manufacturer, to perform the start-up procedures as outlined in the Start-up, Operation and Maintenance manual provided by the chiller manufacturer.
2. Manufacturer shall supply the following literature:
  - a. Start-up, operation and maintenance instructions.
  - b. Installation instructions.

c. Field wiring diagrams.

d. One complete set of certified drawings.

## K. Special Features:

### 1. Soleplate Package Accessory:

Unit manufacturer shall furnish a soleplate package consisting of soleplates, jacking screws, leveling pads, and neoprene pads.

### 2. Spring Isolators Accessory:

Field furnished and selected for the desired degree of isolation.

### 3. Spare Sensors with Leads Accessory:

Unit manufacturer shall furnish additional temperature sensors and leads.

### 4. Stand-Alone Pumpout Unit Accessory:

A free-standing pumpout shall be provided. The pumpout unit shall use a scroll compressor with water-cooled condenser. Condenser water piping, 3-phase motor power shall be installed at the jobsite by the installing contractor.

### 5. Separate Storage Tank and Pumpout Unit Accessory:

A free-standing refrigerant storage tank and pumpout unit shall be provided. The storage vessels shall be designed per ASME Section VIII Division 1 code with 185 psig (1276 kPa) design pressure. Double relief valves per ANSI/ASHRAE 15, latest edition, shall be provided. The tank shall include a liquid level gauge and pressure gauge. The pumpout unit shall use a scroll compressor with water cooled condenser. Condenser water piping and 3-phase motor power shall be installed at the jobsite by the installing contractor.

### 6. Refrigerant Charge:

The chiller shall ship from the factory fully charged with R-515B, R-134a, or R-513A refrigerant.

### 7. Thermal Insulation:

Unit manufacturer shall insulate the evaporator shell, economizer, low side compressor suction elbow, motor shell, and motor cooling lines. Insulation shall be 3/4 in. (19 mm) thick with a thermal conductivity not exceeding 0.28 (Btu in.)/hr ft<sup>2</sup> F [(0.0404 • W)/(m • °C)] and shall conform to UL standard 94, classification 94 HBF.

### 8. Evaporator and Condenser Tubes:

Contact local Carrier representative for other tube offerings.

### 9. Evaporator and Condenser Passes:

Unit manufacturer shall provide the evaporator with 2 pass configuration on the water side.

### 10. Marine Waterboxes, 150 psig (1034 kPa):

Unit manufacturer shall furnish marine style waterboxes on evaporator and/or condenser rated at 150 psig (1034 kPa).

11. Flanged Waterbox Nozzles:

Unit manufacturer shall furnish standard flanged piping connections on the evaporator and/or condenser.

12. Hinges:

Unit manufacturer shall furnish hinges on waterboxes to facilitate tube cleaning.

13. BACnet<sup>1</sup> Communication Option:

Shall provide factory-installed communication capability with a BACnet network. Allows integration with i-Vu<sup>®</sup> Open control system or a BACnet building automation system. (Integration with i-Vu requires the use of UPC Open module.)

---

1. Third-party trademarks and logos are the property of their respective owners.

