

548J
SINGLE PACKAGE HEAT PUMP
6 TO 12.5 NOMINAL TONS

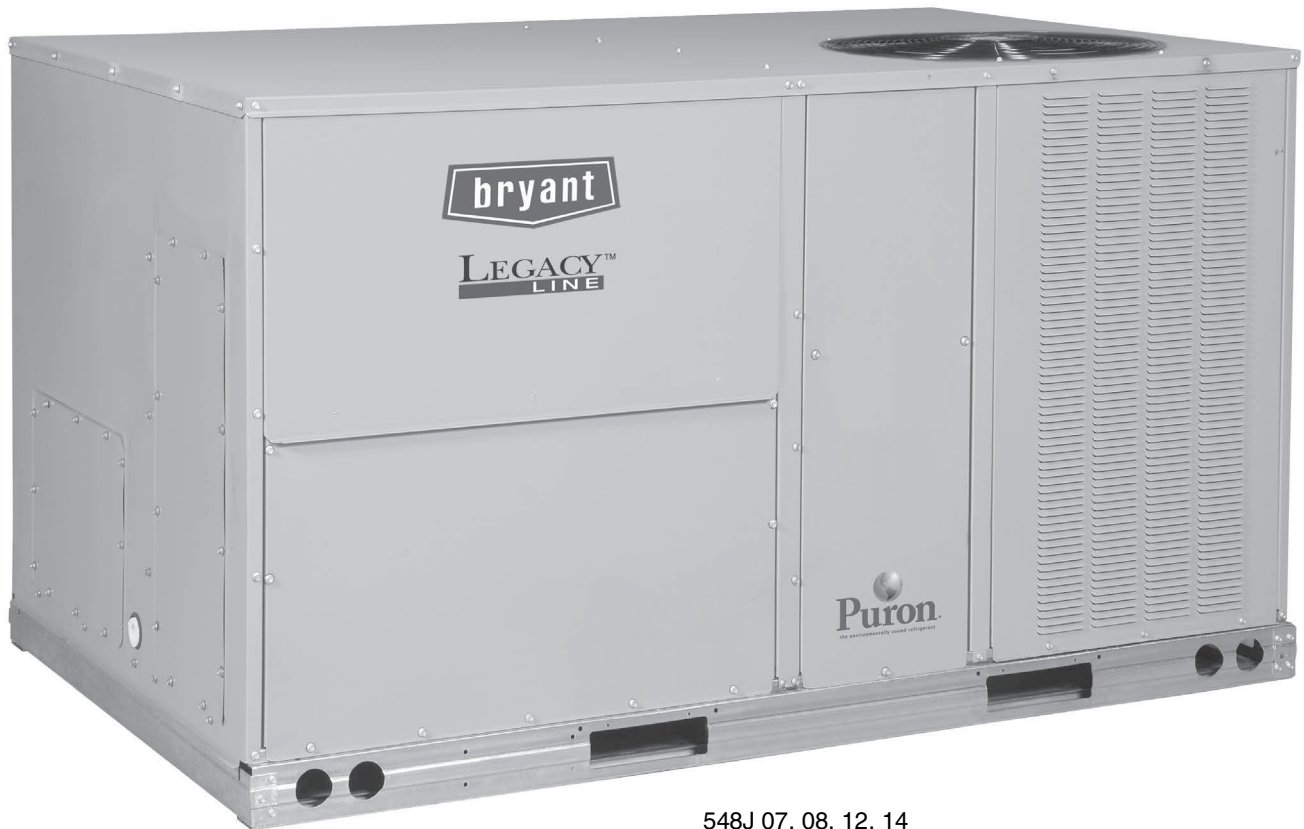

Product Data

LEGACY™
LINE



548J 07, 08, 12, 14
Electric Cooling Rooftop Units with Heat Pump and
Optional Electric Heat with Puron® (R-410A) Refrigerant

Features/Benefits

The Bryant Packaged Heat Pump rooftop unit (RTU) was designed by customers for customers. With no-strip screw collars, handled access panels, and more, we've made your unit easy to install, easy to maintain and easy to use.

Easy to install

All Legacy™ Line units are field-convertible to horizontal air flow which makes it easy to adjust to unexpected job site complications. Lighter units make easy replacement. Bryant 6 to 12.5 ton 548J rooftops fit on existing Bryant curbs dating back to 1989. Also, our large control box gives you room to work and room to mount Bryant accessory controls.

Easy to maintain

Easy access handles by Bryant provide quick and easy access to all normally serviced components. Our “no-strip” screw system has superior holding power and guides screws into position while preventing the screw from stripping the unit’s metal.

Easy to use

The central terminal board puts all your connections and troubleshooting points in one convenient place, standard. Most low voltage connections are made to the same board and make it easy to find what you’re looking for and easy to access it. Bryant rooftops have high and low pressure switches, a filter drier, and 2-in. (51 mm) filters standard.

- EER up to 11.2.
- IEER up to 12.5 with single speed indoor fan motor and up to 12.7 with 2-speed/VFD indoor fan motor.
- 6-12.5 ton units fit on existing Bryant rooftop curbs making the utility

connections the same. This saves time and money on replacement jobs.

- Standardized components and layout. Standardized components and controls make service and stocking parts easier.
- Scroll compressors on all units. This makes service, stocking parts, replacement, and troubleshooting easier.
- Crankcase heater on all models provides added protection in all applications.
- Precision-sized suction line accumulator provides high reliability by preventing liquid from entering the compressor during low ambient conditions and reverse cycle switch over.
- Field convertible from vertical to horizontal airflow configuration on all models. No special kit required on 07-12 models. Supply duct kit required for 14 model only.
- 4-way reversing valve rapidly changes the flow of refrigerant to quickly change over from cooling to heating and heating to cooling.
- Easy-adjust, belt drive motor available on all sizes. There’s no need for field-supplied drives or motors.
- Provisions for bottom or side condensate drain.
- Capable of thru-the-base or thru-the-curb electrical routing.
- Dependable time/temperature defrost logic provides a defrost cycle, if needed, every 30, 60, 90, or 120 minutes and is adjustable.
- Single-point electrical connection.
- Sloped, composite drain pan won’t rust and is self draining.
- Standardized controls and control box layout. Standardized components and controls make stocking parts and service easier.
- Clean, large, easy to use control box.

- Standard coils are copper round tube, aluminum plate fin with optional coil coatings and copper fin design.
- Color-coded wiring.
- Large, laminated wiring and power wiring drawings which are affixed to unit make troubleshooting easy.
- Single, central terminal board for test and wiring connections.
- Fast-access, handled, panels for easy access to the blower and blower motor, control box, and compressors.
- “No-strip” screw system guides screws into the panel and captures them tightly without stripping the screw, the panel, or the unit.
- Exclusive, newly-designed indoor refrigerant header for easier maintenance and replacement.
- Mechanical cooling (115°F to 25°F or 46°C to -4°C) on Electro-mechanical (E/M) and Direct Digital Controller (DDC) (RTU Open controller).
- 2-in. (51 mm) disposable filters on all units.
- High capacity refrigerant filter drier on each circuit.
- High pressure, loss of charge, and freeze switches provide higher protection for the unit refrigeration system.
- 2-Speed Indoor Fan Motor System utilizes a Variable Frequency Drive (VFD) to automatically adjust the indoor fan motor speed between cooling stages. Available on single stage cooling model 07 and 2-stage cooling models, 08-14 with electro-mechanical controls or RTU Open controller. Note that 2-Speed Indoor Fan Motor System is required on all units for installation in the United States as per the Department of Energy (DOE) efficiency standard of 2018.

Table of contents

Features/Benefits	2
Model Number Nomenclature	3
Capacity Ratings	4
Physical Data	6
Options and Accessories	8
Base Unit Dimensions	12
Accessory Dimensions.	26
Performance Data.	29
Fan Data	44
Electrical Data	52
Typical Wiring Diagrams.	96
Sequence of Operation.	102
Application Data	104
Guide Specifications	105

Model number nomenclature

548J MODEL NUMBER NOMENCLATURE

Position:	1	2	3	4	5	6	7	8	9	10	11	12	13	14	15	16	17
Example:	5	4	8	J	P	0	8	D	0	0	0	A	1	B	0	A	A

Unit Type

548 - Packaged Heat Pump
with optional Electric Heat

Model

J - Puron® (R-410A) Refrigerant

Voltage

E = 460-3-60
P = 208/230-3-60
T = 575-3-60

Cooling Tons

07 - 6 ton
08 - 7.5 ton
09 - 8.5 ton
12 - 10 ton
14 - 12.5 ton

Refrig. System Options

A = One-Stage cooling models (size 07 only)
D = Two-Stage cooling models (sizes 08 to 14)

Heat Level

(Field installed electric heaters available)
000 = No Heat

Coil Options (Outdoor - Indoor - Hail Guard)

A = Al/Cu - Al/Cu
B = Precoat Al/Cu - Al/Cu
C = E-coat Al/Cu - Al/Cu
D = E-coat Al/Cu - E-coat Al/Cu
E = Cu/Cu - Al/Cu
F = Cu/Cu - Cu/Cu
M = Al/Cu - Al/Cu — Louvered Hail Guards
N = Precoat Al/Cu - Al/Cu — Louvered Hail Guards
P = E-coat Al/Cu - Al/Cu — Louvered Hail Guards
Q = E-coat Al/Cu - E-coat Al/Cu — Louvered Hail Guards
R = Cu/Cu - Al/Cu — Louvered Hail Guards
S = Cu/Cu - Cu/Cu — Louvered Hail Guards

Packaging and 2-Speed Indoor Fan Motor

A = Standard Packaging
B = LTL Packaging
C = Standard Packaging, electro-mechanical controls that require W7220 EconoMi\$er® X
D = Standard Packaging and 2-speed indoor fan motor
E = LTL Packaging and 2-speed indoor fan motor

Factory Installed Options

0A = None

NOTE: See the 548J 6 to 12.5 ton Price Pages for a complete list of factory installed options.

Outdoor Air Options

A = None
B = Temperature Economizer w/ Barometric Relief, Standard Leak (W7212 or W7220)
E = Temperature Economizer w/ Barometric Relief, Standard Leak with CO₂ (W7212 or W7220)
H = Enthalpy Economizer w/ Barometric Relief, Standard Leak (W7212 or W7220)
L = Enthalpy Economizer w/ Barometric Relief, Standard Leak with CO₂ (W7212 or W7220)
Q = Motorized 2 Position Damper
U = Temperature Economizer w/ Barometric Relief, Ultra Low Leak (W7220)
W = Enthalpy Economizer w/ Barometric Relief, Ultra Low Leak (W7220)

Indoor Fan Options

1 = Standard Static Option – Belt Drive
2 = Medium Static Option – Belt Drive
3 = High Static Option – Belt Drive
C = High Static Option with High Efficiency Motor – Belt Drive (14 size only)

Capacity ratings

AHRI RATINGS – COOLING MODE

548J	COOLING STAGES	NOM. CAPACITY (TONS)	NET COOLING CAPACITY (BTUH)	TOTAL POWER (kW)	EER	IEER WITH SINGLE SPEED INDOOR MOTOR	IEER WITH 2-SPEED INDOOR MOTOR
A07*	1	6	69,000	6.2	11.1	12.5	12.7
D08	2	7.5	88,000	7.8	11.2	12.2	12.5
D09	2	8.5	99,000	8.8	11.2	12.2	12.5
D12	2	10	116,000	10.5	11.0	11.4	12.5
D14	2	12.5	142,000	13.3	10.6	10.7	12.0

AHRI RATINGS – HEATING MODE

548J	HEATING LOW AT 17°F (-8°C) AMBIENT		HEATING HIGH AT 47°F (8°C) AMBIENT	
	CAPACITY (BTUH)	COP	CAPACITY (BTUH)	COP
A07	31,500	2.25	66,000	3.50
D08	44,000	2.25	86,000	3.40
D09	54,500	2.25	96,000	3.30
D12	63,000	2.25	116,000	3.30
D14	76,000	2.05	142,000	3.20

LEGEND

- AHRI** — Air-Conditioning, Heating and Refrigeration Institute
ASHRAE — American Society of Heating, Refrigerating and Air-Conditioning Engineers
COP — Coefficient of Performance
EER — Energy Efficiency Ratio
IECC — International Energy Conservation Code
IEER — Integrated Energy Efficiency Ratio

*Model replaced by 547K*07.

NOTES:

- Rated and certified under AHRI Standard 210/240 or 340/360, as appropriate.
- Ratings are based on:
Cooling Standard: 80°F (27°C) db, 67°F (19°C) wb indoor air temp and 95°F db outdoor air temp.
IEER Standard: A measure that expresses cooling part-load EER efficiency for commercial unitary air conditioning and heat pump equipment on the basis of weighted operation at variable load capacities.
- All 548J units meet the DOE-2018 (Department of Energy), ASHRAE 90.1-2016 and IECC-2015 minimum efficiency requirements when equipped with the 2-Speed Indoor Fan Motor System option.



MINIMUM - MAXIMUM AIRFLOWS (CFM) COOLING AND ELECTRIC HEAT

548J UNIT	COOLING				ELECTRIC HEATERS	
	MINIMUM	MINIMUM 2-SPEED FAN MOTOR (AT HIGH SPEED)	MINIMUM 2-SPEED FAN MOTOR (AT LOW SPEED)	MAXIMUM	MINIMUM	MAXIMUM
A07	1800	1800	1200	3000	1800	3000
D08	2250	2535	1690	3750	2250*	3750
D09	2550	2873	1915	4250	2250*	4250
D12	3000	3000	2000	5000	3000	5000
D14	3750	4056	2704	6250	3750	6250

*Minimum electric heat CFM exceptions (see table below):

UNIT	UNIT VOLTAGE	HEATER kW	UNIT CONFIGURATION	REQUIRED MINIMUM CFM
548JD08 548JD09	575	17.0	Horizontal or Vertical	2800
		34.0		2350

SOUND PERFORMANCE RATINGS

548J UNIT	OUTDOOR SOUND (dB)								
	A-weighted	63	125	250	500	1000	2000	4000	8000
A07	78.0	88.0	79.5	76.2	75.8	72.5	68.6	65.7	62.4
D08	82.0	89.7	81.5	80.5	79.2	77.1	73.2	70.2	67.4
D09	84.0	90.8	85.2	81.6	79.5	78.1	74.0	70.4	66.5
D12	87.0	88.1	90.0	85.9	83.0	81.6	78.5	76.4	75.5
D14	83.0	89.3	85.2	80.3	78.0	77.0	74.4	73.7	68.9

LEGEND

dB — Decibel

NOTES:

1. Outdoor sound data is measured in accordance with AHRI standard 270.
2. Measurements are expressed in terms of sound power. Do not compare these values to sound pressure values because sound pressure accounts for specific environmental factors which do not match individual applications. Sound power values are independent of the environment and therefore more accurate.
3. A-weighted sound ratings filter out very high and very low frequencies, to better approximate the response of an "average" human ear. A-weighted measurements for Bryant units are taken in accordance with AHRI Standard 270.

Physical data

548J 07 PHYSICAL DATA

		548J 07
REFRIGERATION SYSTEM		
	# Circuits / # Comp. / Type	1 / 1 / Scroll
	R-410A charge A/B (lbs - oz)	17 - 10 / -
	oil A/B (oz)	56 / -
	Metering device	Accutrol
	High-pressure trip/reset (psig)	630 / 505
	Low-pressure trip/reset (psig)	27 / 44
EVAP. COIL		
	Material	Cu / Al
	Coil type	3/8-in. RTPF
	Rows / FPI	4 / 15
	Total face area (ft ²)	7.3
	Condensate drain conn. size	3/4-in.
EVAP. FAN AND MOTOR		
Standard Static 3 phase	Motor qty / drive type	1 / Belt
	Max BHP	1.5
	RPM range	878-1192
	Motor frame size	56
	Fan qty / type	1 / Centrifugal
	Fan diameter x length (in.)	10 x 10
Medium Static 3 phase	Motor qty / drive type	1 / Belt
	Max BHP	2.9
	RPM range	1066-1380
	Motor frame size	56
	Fan qty / type	1 / Centrifugal
	Fan diameter x length (in.)	10 x 10
High Static 3 phase	Motor qty / drive type	1 / Belt
	Max BHP	2.9
	RPM range	1208-1550
	Motor frame size	56
	Fan qty / type	1 / Centrifugal
	Fan diameter x length (in.)	10 x 10
COND. COIL		
	Material	Cu / Al
	Coil type	3/8-in. RTPF
	Rows / FPI	2 / 17
	Total face area (ft ²)	21.3
COND. FAN / MOTOR		
	Qty / motor drive type	1 / direct
	Motor HP / RPM	1/4 / 1100
	Fan diameter (in.)	22
FILTERS		
	RA Filter # / size (in.)	4 / 16 x 16 x 2
	OA inlet screen # / size (in.)	1 / 20 x 24 x 1

548J 08-14 PHYSICAL DATA

		548J 08	548J 09	548J 12	548J 14
REFRIGERATION SYSTEM					
	# Circuits / # Comp. / Type	2 / 2 / Scroll	2 / 2 / Scroll	2 / 2 / Scroll	2 / 2 / Scroll
	R-410A charge A/B (lbs - oz)	10 - 3 / 10 - 3	11 - 2 / 11 - 2	15 - 1 / 14 - 1	14 - 8 / 13 - 8
	oil A/B (oz)	42 / 42	42 / 42	—	—
	Metering device	Accutrol	Accutrol	Accutrol	Accutrol
	High-pressure trip/reset (psig)	630 / 505	630 / 505	630 / 505	630 / 505
	Loss of charge pressure trip/reset (psig)	27 / 44	27 / 44	27 / 44	27 / 44
EVAP. COIL					
	Material	Cu / Al	Cu / Al	Cu / Al	Cu / Al
	Coil type	3/8-in. RTPF	3/8-in. RTPF	3/8-in. RTPF	3/8-in. RTPF
	Rows / FPI	3 / 15	4 / 15	4 / 15	3 / 15
	Total face area (ft ²)	11.1	11.1	11.1	17.5
	Condensate drain conn. size	3/4-in.	3/4-in.	3/4-in.	3/4-in.
EVAP. FAN AND MOTOR					
Standard Static 3 phase	Motor qty / drive type	1 / Belt	1 / Belt	1 / Belt	1 / Belt
	Max BHP	1.2	1.2	1.7	2.9
	RPM range	460-652	460-652	591-839	507-676
	Motor frame size	56	56	56	56
	Fan qty / type	1 / Centrifugal	1 / Centrifugal	1 / Centrifugal	1 / Centrifugal
	Fan diameter x length (in.)	15 x 15	15 x 15	15 x 15	18 x 18
Medium Static 3 phase	Motor qty / drive type	1 / Belt	1 / Belt	1 / Belt	1 / Belt
	Max BHP	2.9	2.9	2.8	2.9
	RPM range	591-838	591-838	733-949	634-833
	Motor frame size	56	56	56	56
	Fan qty / type	1 / Centrifugal	1 / Centrifugal	1 / Centrifugal	1 / Centrifugal
	Fan diameter x length (in.)	15 x 15	15 x 15	15 x 15	18 x 18
High Static 3 phase	Motor qty / drive type	1 / Belt	1 / Belt	1 / Belt	—
	Max BHP	2.9	2.9	4.0	—
	RPM range	838-1084	838-1084	838-1084	—
	Motor frame size	56	56	56	—
	Fan qty / type	1 / Centrifugal	1 / Centrifugal	1 / Centrifugal	—
	Fan diameter x length (in.)	15 x 15	15 x 15	15 x 15	—
High Static- High Efficiency 3 phase	Motor qty / drive type	—	—	—	1 / Belt
	Max BHP	—	—	—	6.5 / 6.9 / 7.0 / 8.3
	RPM range	—	—	—	792-971
	Motor frame size	—	—	—	S184T
	Fan qty / type	—	—	—	1 / Centrifugal
	Fan diameter x length (in.)	—	—	—	18 x 18
COND. COIL					
	Material	Cu / Al	Cu / Al	Cu / Al	Cu / Al
	Coil type	3/8-in. RTPF	3/8-in. RTPF	3/8-in. RTPF	3/8-in. RTPF
	Rows / FPI	2 / 17	2 / 17	3 / 17	2 / 17
	Total face area (ft ²)	25.1	25.1	25.1	36.1
COND. FAN / MOTOR					
	Qty / motor drive type	2 / direct	2 / direct	1 / direct	3 / direct
	Motor HP / RPM	1/4 / 1100	1/4 / 1100	1 / 1175	1/4 / 1100
	Fan diameter (in.)	22	22	30	22
FILTERS					
	RA Filter # / size (in.)	4 / 20 x 20 x 2	4 / 20 x 20 x 2	4 / 20 x 20 x 2	6 / 18 x 24 x 2
	OA inlet screen # / size (in.)	1 / 20 x 24 x 1	1 / 20 x 24 x 1	1 / 20 x 24 x 1	2 / 24 x 27 x 1 (Vertical) 1 / 30 x 39 x 1 (Horizontal)

Options and accessories

FACTORY-INSTALLED OPTIONS AND FIELD-INSTALLED ACCESSORIES

CATEGORY	ITEM	FACTORY-INSTALLED OPTION	FIELD-INSTALLED ACCESSORY
Cabinet	Thru-the-base electrical connections	X	X
	Disconnect switch bracket (available 14 size only)		X
	Supply duct cover (available 14 size only)		X
Coil Options	Cu/Cu indoor and/or outdoor coils	X	
	Pre-coated outdoor coils	X	
	Premium, E-coated outdoor coils	X	
Condenser Protection	Condenser coil hail guard (louvered design)	X	X
Controls	Thermostats, temperature sensors, and subbases		X
	RTU Open multi-protocol controller	X	
	Smoke detector (supply and/or return air)	X	
	Horn/Strobe annunciator ¹		X
	Time Guard II compressor delay control circuit		X
	Phase monitor		X
	Condensate overflow switch	X	X
Economizers and Outdoor Air Dampers	EconoMi\$er® IV for electro-mechanical controls - Non FDD, (Low leak air damper models) ²	X	X
	EconoMi\$er 2 for DDC controls, complies with FDD (Low Leak and Ultra Low Leak air damper models) ^{3 6}	X	X
	EconoMi\$er X for electro-mechanical controls, complies with FDD (Low Leak and Ultra Low Leak air damper controls) ³	X	X
	Motorized 2 position outdoor air damper ¹	X	X
	Manual outdoor air damper (25% and 50%) ¹		X
	Barometric relief ⁴	X	X
	Power exhaust		X
Economizer Sensors and IAQ Devices	Single dry bulb temperature sensors ⁵	X	X
	Differential dry bulb temperature sensors ⁶		X
	Single enthalpy sensors ⁶	X	X
	Differential enthalpy sensors ⁶		X
	CO ₂ sensor (wall, duct, or unit mounted) ⁶	X	X
Electric Heat	Winter start kit		X
	Electric resistance heaters		X
	Single point kit		X
Indoor Motor and Drive	Hinged access panels	X	
	Multiple motor and belt drive packages	X	
	2-Speed Indoor Fan Motor System with VFD controller (for units with electrical mechanical and RTU Open controller only) ⁶	X	
Low Ambient Control	Display kit for 2-Speed Indoor Fan Motor System with VFD		X
	Motormaster® head pressure controller ⁷		X
Power Options	Convenience outlet (powered)	X	
	Convenience outlet (unpowered): 15 amp factory-installed, 20 amp field-installed	X	X
	Non-fused disconnect ⁸	X	
Roof Curbs	Roof curb 14-in. (356 mm)		X
	Roof curb 24-in. (610 mm)		X

NOTES:

- Requires a field-supplied 24V transformer for each application. See price pages for details.
- FDD (Fault Detection and Diagnostic) capability per California Title 24 section 120.2.
- Models with RTU Open DDC controls comply with California Title 24 Fault Detection and Diagnostic (FDD).
- Included with economizer.
- Sensors for optimizing economizer performance.
- 2-speed indoor fan motor system is required on all units for installation in the United States as per the Department of Energy (DOE) efficiency standard of 2018.
- See application data for assistance.
- Available on size 07-12 units with MOCPs of 80 amps or less and on size 14 units with MOCPs of 100 amps or less.

Economizer

Economizers can reduce operating costs. They bring in fresh, outside air for ventilation; and provide cool, outside air to cool your building. This is the preferred method of low ambient cooling. When coupled to CO₂ sensors, economizers can limit the ventilation air to only that amount required.

Economizers are available, installed and tested by the factory, with either enthalpy or dry bulb temperature inputs. There are also models for electro-mechanical as well as direct digital controllers. Additional sensors are available as accessories to optimize the economizers.

Economizers include gravity controlled, barometric relief which equalizes building pressure and ambient air pressures. This can be a cost effective solution to prevent building pressurization. Economizers are available in ultra low leak and low leak versions.

CO₂ Sensor

The CO₂ sensor works with the economizer to intake only the correct amount of outside air for ventilation. As occupants fill your building, the CO₂ sensor detects their presence through increasing CO₂ levels, and opens the economizer appropriately.

When the occupants leave, the CO₂ levels decrease, and the sensor appropriately closes the economizer. This intelligent control of the ventilation air, called Demand Controlled Ventilation (DCV), reduces the overall load on the rooftop, saving money.

Smoke Detectors

Trust the experts. Smoke detectors make your application safer and your job easier. Bryant smoke detectors immediately shut down the rooftop unit when smoke is detected. They are available, installed by the factory, for supply air, return air, or both.

Louvered Hail Guards

Sleek, louvered panels protect the condenser coil from hail damage, foreign objects, and incidental contact.

Convenience Outlet (powered or un-powered)

Reduce service and/or installation costs by including a convenience outlet in your specification. Bryant will install this service feature at our factory. Provides a convenient, 15 amp, 115v GFCI receptacle with "Wet in Use" cover. The "powered" option allows the installer to power the outlet from the line side of the disconnect as required by code. The "unpowered" option is to be powered from a separate (non-unit) 115/120v power source. The unpowered convenience outlet is available as a 15 amp factory-installed option or a 20 amp field-installed accessory.

The 20 amp unpowered convenience outlet kit provides a flexible installation method which allows code compliance for height requirements of the GFCI outlet from the finished roof surface as well as the capability to relocate the outlet to a more convenient location, if necessary.

Non-Fused Disconnect

This OSHA-compliant, factory-installed, safety switch allows a service technician to locally secure power to the rooftop.

When selecting a factory-installed non-fused disconnect, note they are sized for unit as ordered from the factory. The sizing of these does not accommodate any power exhaust devices, etc.

Power Exhaust Pressure Relief

Superior internal building pressure control. This field-installed accessory may eliminate the need for costly, external pressure control fans.

RTU Open, Multi-protocol Controller

Connect the rooftop to an existing BAS without needing complicated translators or adapter modules using the RTU Open controller. This controller speaks the 4 most common building automation system languages (BACnet¹, Modbus², N2, and LonWorks³) Use this controller when you have an existing BAS.

Time Guard II Control Circuit

This accessory protects the compressor by preventing short-cycling in the event of some other failure, prevents the compressor from restarting for 30 seconds after stopping. Not required with RTU Open controller or authorized commercial thermostats.

Filter or Fan Status Switches

Use these differential pressure switches to detect a filter clog or indoor fan motor failure. When used in conjunction with a compatible unit controller/thermostat, the switches will activate an alarm to warn the appropriate personnel.

Motorized 2-Position Damper

The Bryant 2-position, motorized outdoor air damper admits up to 100% outside air. Using gear-driven technology, the 2-position damper opens to allow ventilation air and closes when the rooftop stops, stopping unwanted infiltration. Not available with 2-speed indoor fan motor system.

Manual OA Damper

Manual outdoor air dampers are an economical way to bring in ventilation air. The dampers are available in 25% and 50% versions. Not available with 2-speed indoor fan motor system.

2-Speed Indoor Fan Motor System

Bryant's 2-speed indoor fan motor system saves energy and installation time by utilizing a Variable Frequency Drive (VFD) to automatically adjust the indoor fan motor speed in sequence with the units cooling operation. Per ASHRAE 90.1-2016 and IECC⁴-2015 standards, during the first stage of cooling operation the VFD will adjust the fan motor to provide 66% of the total cfm established for the unit. When a call for the second stage of cooling is required, the VFD will allow the total cfm for the unit established (100%). During the heating mode the VFD will allow total design cfm (100%) operation and during the ventilation mode the VFD will allow operation to 66% of total cfm.

Compared to single speed indoor fan motor systems, Bryant's 2-speed indoor fan motor system can save substantial energy, 25%+, versus single speed indoor fan motor systems.

-
1. BACnet is a registered trademark of ASHRAE (American Society of Heating, Refrigerating and Air-Conditioning Engineers).
 2. Modbus is a registered trademark of Schneider Electric.
 3. LonWorks is a registered trademark of Echelon Corporation.
 4. IECC is a registered trademark of International Code Council, Inc.

Options and accessories (cont)

IMPORTANT: Data based on 0.10 (\$/kWh) in an office application utilizing Bryant's HAP 4.6 simulation software program.

The VFD used in Bryant's 2-speed indoor fan motor system has soft start capabilities to slowly ramp up the speeds, thus eliminating any high inrush air volume during initial start-up. It also has internal over current protection for the fan motor and a field-installed display kit that allows adjustment and in depth diagnostics of the VFD.

This 2-speed indoor fan motor system is available on models with electrical mechanical or RTU Open, Multi Protocol controls. Both space sensor and conventional thermostats controls can be used to provide accurate control in any application.

The 2-speed indoor fan motor system is very flexible for initial fan performance set up and adjustment. The standard factory shipped VFD is pre-programmed to automatically stage the fan speed between the first and second stage of cooling. The unit fan performance static pressure and cfm can be easily adjusted using the traditional means of pulley adjustments. The other means to adjust the unit static and cfm performance is to utilize the field-installed display kit and adjust the frequency and voltage in the VFD to required performance requirements. In either case, once set up, the VFD will automatically adjust the speed between the cooling stage operations.

2-SPEED INDOOR FAN MOTOR SYSTEM— VARIABLE FREQUENCY DRIVE (VFD) HP RATING

548J	VOLTAGE	STATIC OPTION	HP
07	208/230, 460, 575	STD	3.0
	208/230, 460	MED	3.0
	575	MED	5.0
	208/230	HIGH	3.0
	460, 575	HIGH	5.0
08	208/230, 460, 575	STD	3.0
	208/230, 460	MED	3.0
	575	MED	5.0
	208/230, 460, 575	HIGH	7.5
09	208/230, 460, 575	STD	3.0
	208/230, 460, 575	MED	3.0
	208/230	HIGH	3.0
12	460, 575	HIGH	5.0
	208/230, 460, 575	STD	3.0
	208/230	MED	3.0
	460, 575	MED	5.0
14	208/230, 460, 575	HIGH	7.5
	208/230, 460	STD	3.0
	575	STD	5.0
	208/230	MED	3.0
	460, 575	MED	5.0
	208/230, 460, 575	HIGH	7.5

Motormaster® Head Pressure Controller

The Motormaster motor controller is a low ambient, head pressure controller kit that is designed to maintain the unit's condenser head pressure during periods of low ambient cooling operation. This device should be used as an alternative to economizer free cooling when economizer usage is either not appropriate or desired. The Motormaster controller will either cycle the outdoor fan motors or operate them at reduced speed to maintain the unit operation, depending on the model.

The Motormaster controller allows cooling operation down to -20°F (-29°C) ambient conditions.

Alternate Motors and Drives

Some applications need larger horsepower motors, some need more airflow, and some need both. Regardless of the case, your Bryant expert has a factory-installed combination to meet your application. A wide selection of motors and pulleys (drives) are available, factory-installed, to handle nearly any application.

Thru-the-Base Connections

Thru-the-base connections, available as either an accessory or as a factory option, are necessary to ensure proper connection and seal when routing wire and piping through the rooftop's basepan and curb. These couplings eliminate roof penetration and should be considered for gas lines, main power lines, as well as control power.

Disconnect Switch Bracket

Provides a pre-engineered and sized mounting bracket for applications requiring a unit mounted fused disconnect of greater than 100 amps. Bracket assures that no damage will occur to coils when mounting with screws and other fasteners. (Size 14 only.)

Supply Duct Cover

This supply duct cover is required when field converting the factory standard vertical duct supply to horizontal duct supply configuration. One is required per unit. (Size 14 only.)

Electric Heaters

Bryant offers a full line of field-installed accessory heaters. The heaters are very easy to use and install. All are pre-engineered and certified.

548J OPTION/ACCESSORY WEIGHTS

OPTION/ACCESSORY	WEIGHTS									
	07		08		09		12		14	
	lb	kg	lb	kg	lb	kg	lb	kg	lb	kg
Power Exhaust — Vertical	50	23	75	34	75	34	75	34	85	39
Power Exhaust — Horizontal	30	14	30	14	30	14	30	14	75	34
EconoMiSer (IV, X or 2)	50	23	75	34	75	34	75	34	115	52
Two Position Damper	39	18	58	26	58	26	58	26	65	29
Manual Dampers	12	5	18	8	18	8	18	8	25	11
Hail Guard (louvered)	16	7	34	15	34	15	34	15	45	20
Cu/Cu Condenser Coil	95	43	95	43	95	43	170	77	190	86
Cu/Cu Cond. and Evaporator Coils	165	75	140	64	195	88	270	122	280	127
Roof Curb (14-in. curb)	115	52	143	65	143	65	143	65	180	82
Roof Curb (24-in. curb)	197	89	245	111	245	111	245	111	255	116
CO ₂ sensor	5	2	5	2	5	2	5	2	5	2
Electric Heater	30	14	45	20	45	20	45	20	25	11
Single Point Kit	10	5	12	5	12	5	12	5	25	11
Optional Indoor Motor / Drive	10	5	15	7	15	7	15	7	45	20
Motormaster Controller	35	16	35	16	35	16	35	16	35	16
Return Smoke Detector	5	2	5	2	5	2	5	2	5	2
Supply Smoke Detector	5	2	5	2	5	2	5	2	5	2
Non-Fused Disconnect	15	7	15	7	15	7	15	7	15	7
Powered Convenience Outlet	35	16	35	16	35	16	35	16	35	16
Non-Powered Convenience Outlet	5	2	5	2	5	2	5	2	4	2
Enthalpy Sensor	2	1	2	1	2	1	2	1	2	1
Differential Enthalpy Sensor	3	1	3	1	3	1	3	1	3	1
2-Speed Indoor Fan Motor System with VFD	—	—	20	9	20	9	20	9	20	9



LEGEND

— Not available

NOTE: Where multiple variations are available, the heaviest combination is listed.

DIMENSIONS OF 548J 07 UNITS BUILT ON AND AFTER 4/15/2019

NOTES:

1. DIMENSIONS ARE IN INCHES. DIMENSIONS IN [] ARE IN MILLIMETERS.
2.  CENTER OF GRAVITY
3.  DIRECTION OF AIR FLOW
4.  ALL VIEW DRAWN USING 3RD ANGLE

DRAWING REPRESENTS PRODUCT BUILT ON AND AFTER 04/15/2019 (STARTING WITH SERIAL NUMBER 1619...) SEE DETAIL "E" SHT 5



THIS DOCUMENT IS THE PROPERTY OF UTC CLIMATE CONTROLS & SECURITY AND IS DELIVERED UPON THE EXPRESS CONDITION THAT THE CONTENTS WILL NOT BE DISCLOSED WITHOUT WRITTEN CONSENT.

SUBMISSION OF THESE DRAWINGS OR DOCUMENTS DOES NOT CONSTITUTE PART PERFORMANCE OR ACCEPTANCE OF CONTRACT.

UNIT	J	K
548J-07A	41 3/8 [1051]	14 7/8 [377]

CONNECTION SIZES		
A	1 3/8" [35]	DIA FIELD POWER SUPPLY HOLE
B	2" [51]	DIA POWER SUPPLY KNOCKOUT
C	1 3/4" [44]	DIA GAUGE ACCESS PLUG
D	7/8" [22]	DIA FIELD CONTROL WIRING HOLE
E	3/4"-14	NPT CONDENSATE DRAIN
G	2 1/2" [64]	DIA POWER SUPPLY KNOCK-OUT

THRU-THE-BASE CHART THESE HOLES REQUIRED FOR USE CRBTMPWRO08A00			
	THREADED CONDUIT SIZE	WIRE USE	REQ'D HOLE SIZES (MAX.)
W	1/2"	115V	7/8" [22.2]
X	1/2"	24V	7/8" [22.2]
Y	3/4"	POWER	1-1/8" [28.6]

FOR "THRU-THE-BASEPAN" FACTORY OPTION, FITTINGS FOR ONLY X & Y ARE PROVIDED (008A00) PROVIDES 3/4" FPT THRU CURB FLANGE & FITTING

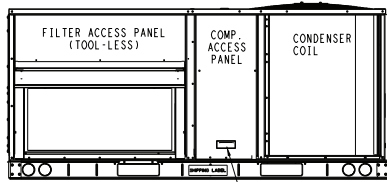

BACK

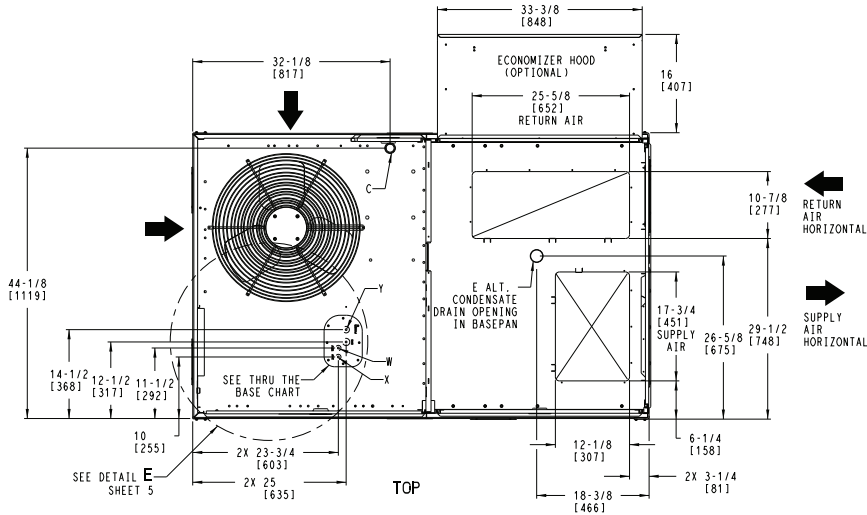

TOP

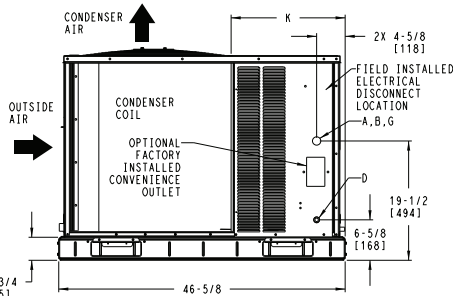

LEFT

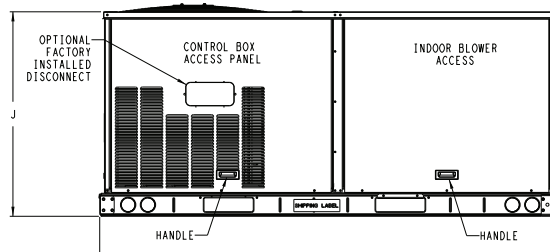

FRONT

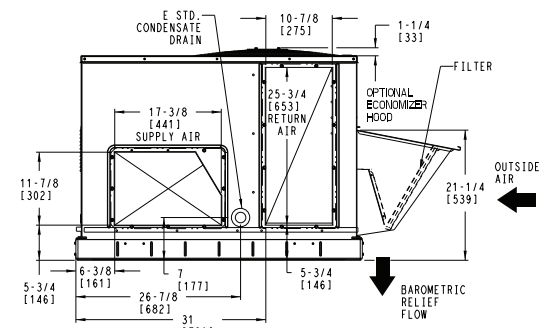

RIGHT

ITC CLASSIFICATION	SHEET	DATE	SUPERCEDES	548J 07 SINGLE ZONE ELECTRIC HEAT PUMP	48T501502	REV
U.S. ECCN:NSR	1 OF 5	01-04-19	03-10-09			F

DIMENSIONS OF 548J 07 UNITS BUILT PRIOR TO 4/15/2019

NOTES:

1. DIMENSIONS ARE IN INCHES. DIMENSIONS IN [] ARE IN MILLIMETERS.
2. CENTER OF GRAVITY
3. DIRECTION OF AIR FLOW
4. ALL VIEW DRAWN USING 3RD ANGLE

DRAWING REPRESENTS PRODUCT BUILT ON AND PRIOR TO 04/14/2019
SEE DETAIL "B" SHT 5



THIS DOCUMENT IS THE PROPERTY OF UTC CLIMATE, CONTROLS & SECURITY AND IS DELIVERED UPON THE EXPRESS CONDITION THAT THE CONTENTS WILL NOT BE DISCLOSED WITHOUT WRITTEN CONSENT.

SUBMISSION OF THESE DRAWINGS OR DOCUMENTS DOES NOT CONSTITUTE PART PERFORMANCE OR ACCEPTANCE OF CONTRACT.

UNIT	J	K
548J-07A	41 3/8 [1051]	14 7/8 [377]

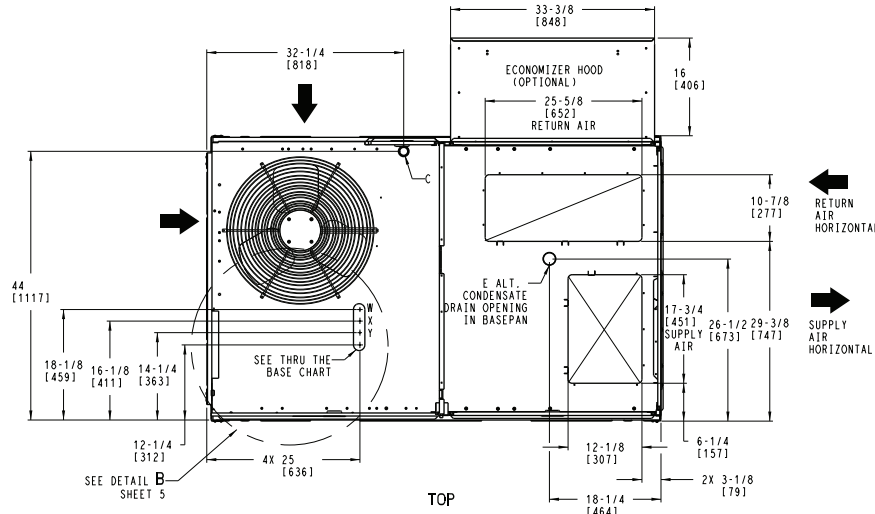
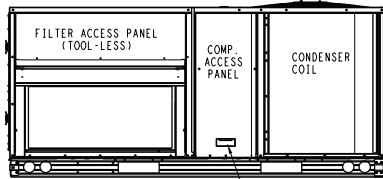

CONNECTION SIZES	
A	1 3/8" [35] DIA FIELD POWER SUPPLY HOLE
B	2" [51] DIA POWER SUPPLY KNOCKOUT
C	1 3/4" [44] DIA GAUGE ACCESS PLUG
D	7/8" [22] DIA FIELD CONTROL WIRING HOLE
E	3/4"-14 NPT CONDENSATE DRAIN
G	2 1/2" [64] DIA POWER SUPPLY KNOCK-OUT

THRU-THE-BASE CHART THESE HOLES REQUIRED FOR USE CRBTMPW001A01			
	THREADED CONDUIT SIZE	WIRE USE	REQ'D HOLE SIZES (MAX.)
W	1/2"	115V	7/8" [22.2]
X	1/2"	24V	7/8" [22.2]
Y*	3/4"	POWER	1 1/8" [28.6]

FOR "THRU-THE-BASEPAN" FACTORY OPTION, FITTINGS FOR ONLY X & Y ARE PROVIDED

* SELECT EITHER 3/4" OR 1/2" FOR POWER, DEPENDING ON WIRE SIZE
(001A01) PROVIDES 3/4" FPT THRU CURB FLANGE & FITTING

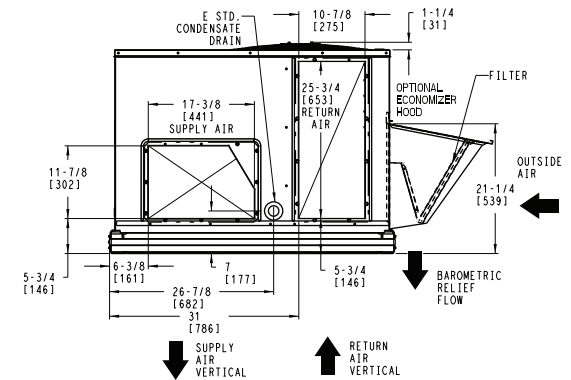
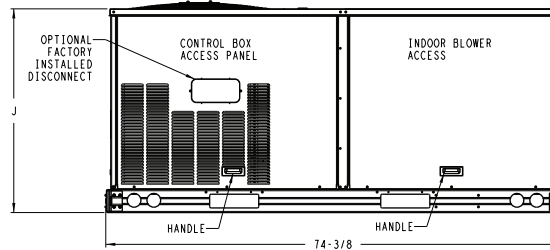
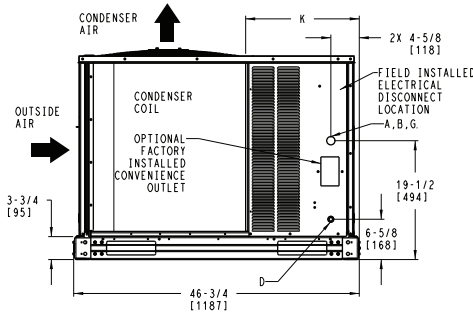

I/T CLASSIFICATION	SHEET	DATE	SUPERCEDES	548J 07 SINGLE ZONE ELECTRIC HEAT PUMP	48TM501502	REV
U.S. ECCN:NSR	2 OF 5	01-04-19	03-10-09			F

548J 07 CORNER WEIGHTS AND CLEARANCES



THIS DOCUMENT IS THE PROPERTY OF UTC CLIMATE CONTROLS & SECURITY AND IS DELIVERED UPON THE EXPRESS CONDITION THAT THE CONTENTS WILL NOT BE DISCLOSED WITHOUT WRITTEN CONSENT. SUBMISSION OF THESE DRAWINGS OR DOCUMENTS DOES NOT CONSTITUTE PART PERFORMANCE OR ACCEPTANCE OF CONTRACT.

UNIT	STD. UNIT WEIGHT		CORNER WEIGHT (A)		CORNER WEIGHT (B)		CORNER WEIGHT (C)		CORNER WEIGHT (D)		C.G.			HEIGHT
	LBS.	KG.	LBS.	KG.	LBS.	KG.	LBS.	KG.	LBS.	KG.	X	Y	Z	
548J-07A	630	286	166	75	166	75	149	68	149	68	37 1/4 [946]	22 1/8 [562]	20 3/4 [527]	

CORNER A

CORNER B

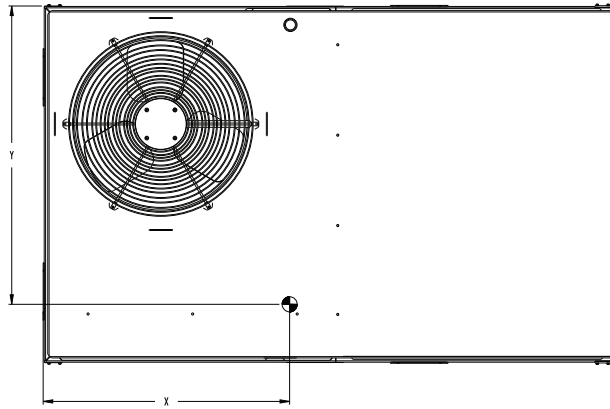

TOP

CORNER D

CORNER C

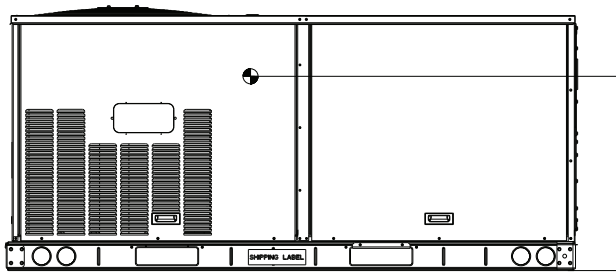

FRONT

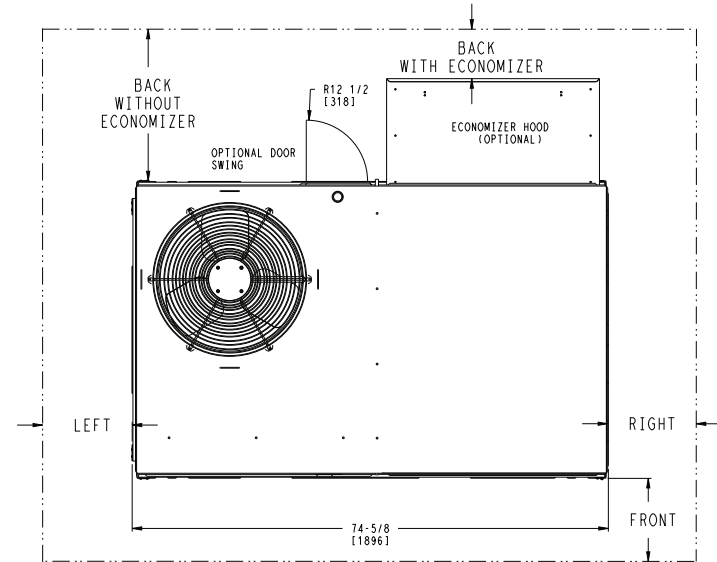

NOTES:

- FOR ALL MINIMUM CLEARANCES LOCAL CODES OR JURISDICTIONS MAY PREVAIL.

SURFACE	CLEARANCE		OPERATING CLEARANCE
	SERVICE WITH CONDUCTIVE BARRIER	SERVICE WITH NONCONDUCTIVE BARRIER	
FRONT	48 [1219mm]	36 [914mm]	18 [457mm]
LEFT	48 [1219mm]	42 [1067mm]	18 [457mm]
BACK	48 [1219mm]	42 [1067mm]	18 [457mm]
BACK W/HOOD	36 [914mm]	36 [914mm]	18 [457mm]
RIGHT	36 [914mm]	36 [914mm]	18 [457mm]
TOP	72 [1829mm]	72 [1829mm]	72 [1829mm]

IITC CLASSIFICATION U.S. ECCN:NSR	SHEET 3 OF 5	DATE 01-04-19	SUPERCEDES 03-10-09	548J 07 SINGLE ZONE ELECTRIC HEAT PUMP	48TM501502	REV F
--------------------------------------	-----------------	------------------	------------------------	--	------------	----------

548J 07 BASE RAIL DETAILS



THIS DOCUMENT IS THE PROPERTY OF UTC CLIMATE CONTROLS & SECURITY AND IS DELIVERED UPON THE EXPRESS CONDITION THAT THE CONTENTS WILL NOT BE DISCLOSED WITHOUT WRITTEN CONSENT.

SUBMISSION OF THESE DRAWINGS OR DOCUMENTS DOES NOT CONSTITUTE PART PERFORMANCE OR ACCEPTANCE OF CONTRACT.

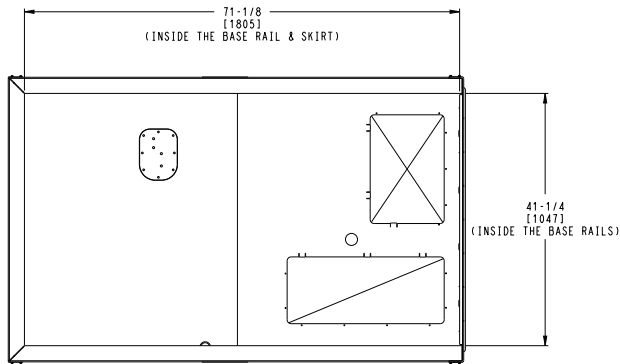
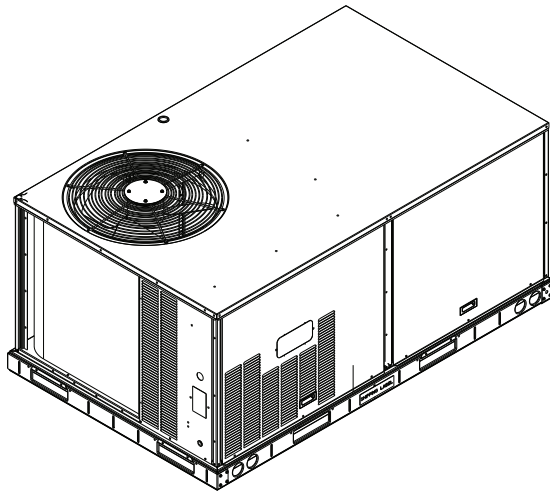

INSIDE BASERAIL DIMENSIONS
BOTTOM

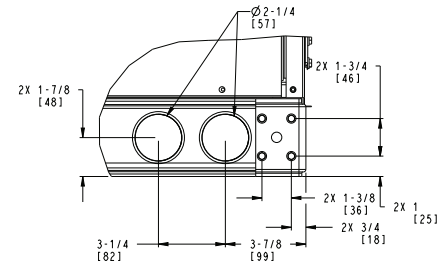

DETAIL C
TYP 2 PLCS

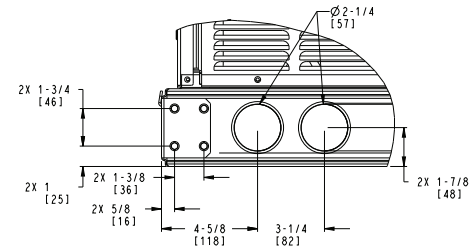

DETAIL D
TYP 2 PLCS

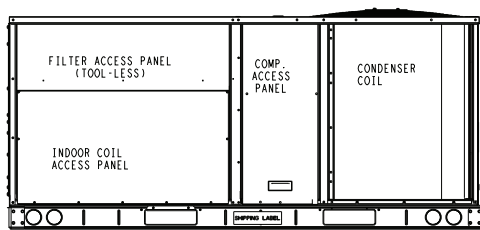

BACK

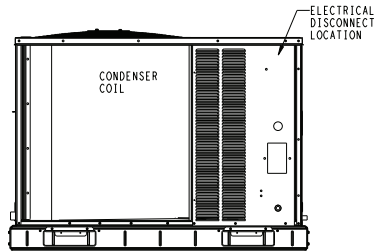

LEFT

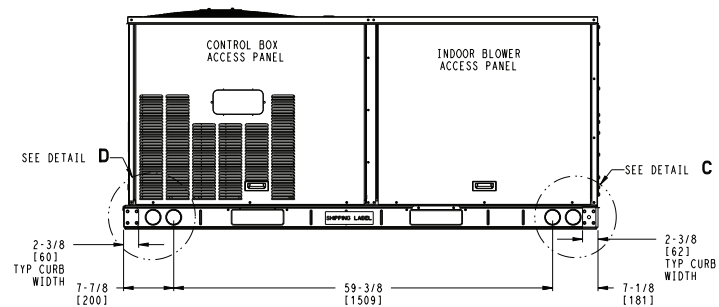

FRONT

IITC CLASSIFICATION U.S. ECCN:NSR	SHEET 4 OF 5	DATE 01-04-19	SUPERCEDES 03-10-09	548J 07 SINGLE ZONE ELECTRIC HEAT PUMP	48TM501502	REV F
--------------------------------------	-----------------	------------------	------------------------	---	------------	----------

548J 07 THRU-THE-BASE CHARTS



THIS DOCUMENT IS THE PROPERTY OF UTC CLIMATE, CONTROLS & SECURITY AND IS DELIVERED UPON THE EXPRESS CONDITION THAT THE CONTENTS WILL NOT BE DISCLOSED WITHOUT WRITTEN CONSENT. SUBMISSION OF THESE DRAWINGS OR DOCUMENTS DOES NOT CONSTITUTE PART PERFORMANCE OR ACCEPTANCE OF CONTRACT.

THRU-THE-BASE CHART THESE HOLES REQUIRED FOR USE CRBTMPWR001A01			
	THREADED CONDUIT SIZE	WIRE USE	REQ'D HOLE SIZES (MAX.)
W	1/2"	115V	7/8" [22.2]
X	1/2"	24V	7/8" [22.2]
Y *	3/4"	POWER	1 1/8" [28.6]
FOR "THRU-THE-BASEPAN" FACTORY OPTION, FITTINGS FOR ONLY X & Y ARE PROVIDED			
* SELECT EITHER 3/4" OR 1/2" FOR POWER, DEPENDING ON WIRE SIZE			
(001A01) PROVIDES 3/4" FPT THRU CURB FLANGE & FITTING			

THRU-THE-BASE CHART THESE HOLES REQUIRED FOR USE CRBTMPWR008A00			
	THREADED CONDUIT SIZE	WIRE USE	REQ'D HOLE SIZES (MAX.)
W	1/2"	115V	7/8" [22.2]
X	1/2"	24V	7/8" [22.2]
Y	3/4"	POWER	1-1/8" [28.6]
FOR "THRU-THE-BASEPAN" FACTORY OPTION, FITTINGS FOR ONLY X & Y ARE PROVIDED			
(008A00) PROVIDES 3/4" FPT THRU CURB FLANGE & FITTING			

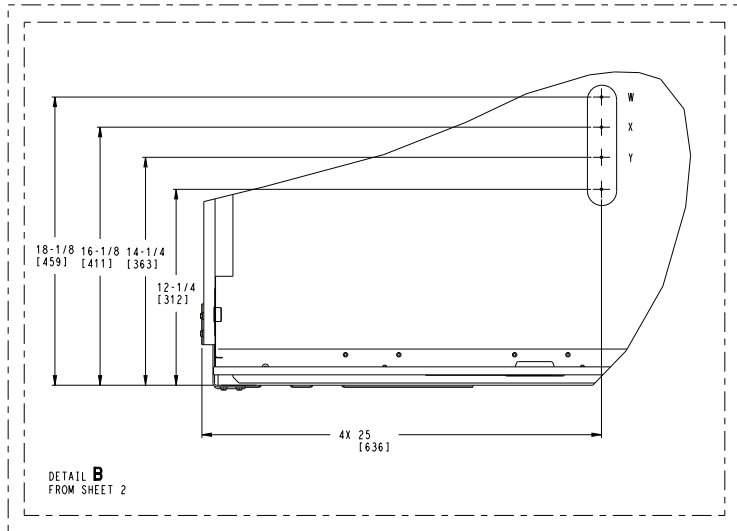

THIS VIEW REPRESENTS PRODUCT BUILT ON AND PRIOR TO 04/14/2019

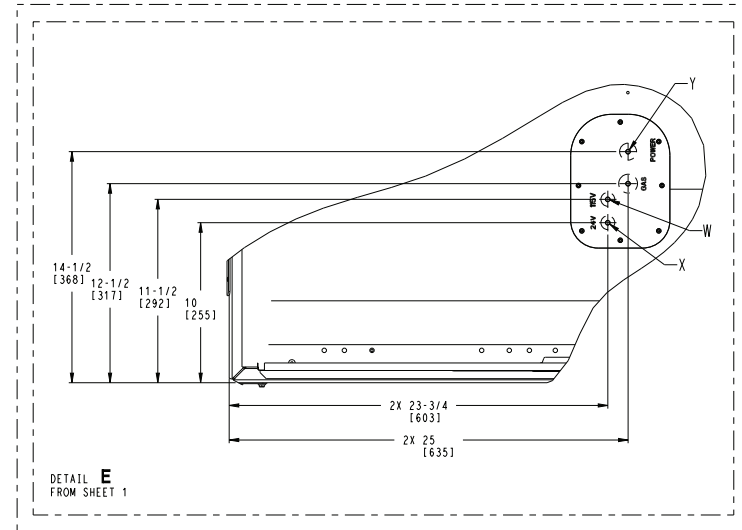

THIS VIEW REPRESENTS PRODUCT BUILT ON AND AFTER 04/15/2019

IIC CLASSIFICATION U.S. ECCN:NSR	SHEET 5 OF 5	DATE 01-04-19	SUPERCEDES 03-10-09	548J 07 SINGLE ZONE ELECTRIC HEAT PUMP	48TMS01502	REV F
-------------------------------------	-----------------	------------------	------------------------	---	------------	----------

548J 08-09 UNIT DIMENSIONS

NOTES:

1. DIMENSIONS ARE IN INCHES. DIMENSIONS IN [] ARE IN MILLIMETERS.
2. CENTER OF GRAVITY
3. DIRECTION OF AIR FLOW

UNIT	J	K	H
548J-D08	49 3/8 [1253]	33 3/4 [857]	23 7/8 [609]
548J-D09	49 3/8 [1253]	36 3/8 [925]	23 7/8 [609]

THIS DOCUMENT IS THE PROPERTY OF CARRIER CORPORATION AND IS DELIVERED UPON THE EXPRESS CONDITION THAT THE CONTENTS WILL NOT BE DISCLOSED OR USED WITHOUT CARRIER CORPORATION'S WRITTEN CONSENT.

SUBMISSION OF THESE DRAWINGS OR DOCUMENTS DOES NOT CONSTITUTE PART PERFORMANCE OR ACCEPTANCE OF CONTRACT.

CONNECTION SIZES	
A	1 3/8" [351] DIA. FIELD POWER SUPPLY HOLE
B	2 1/2" [64] DIA. POWER SUPPLY KNOCKOUT
C	1 3/4" [51] DIA. GAUGE ACCESS PLUG
D	7/8" [22] DIA. FIELD CONTROL WIRING HOLE
E	3/4"-14 NPT CONDENSATE DRAIN
G	2" [51] DIA. POWER SUPPLY KNOCK-OUT

THRU-THE-BASE CHART THESE HOLES REQUIRED FOR USE (CRBTMPWR002A0)			
	THREADED CONDUIT SIZE	WIRE USE	REQ'D HOLE SIZES (MAX.)
W	1/2"	ACC.	7/8" [22.2]
X	1/2"	24V	7/8" [22.2]
Y	1 1/4" (002)	POWER	1 3/4" [44.4]

FOR "THRU-THE-BASEPAN" FACTORY OPTION, FITTINGS FOR ONLY X & Y ARE PROVIDED

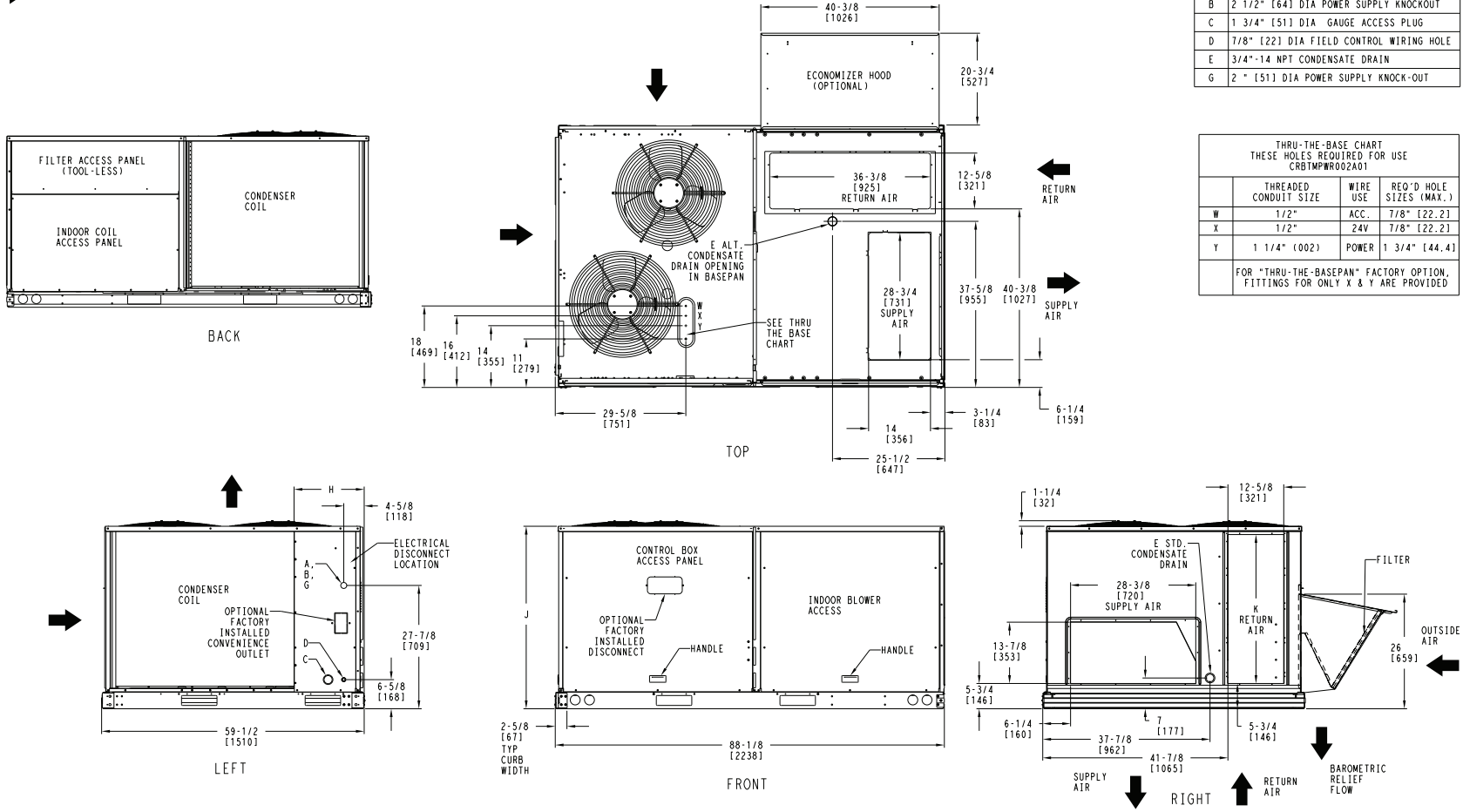

SHEET 1 OF 2	DATE 10-04-10	SUPERCEDES 03-10-09	548J 08-09 SINGLE ZONE ELECTRIC HEAT PUMP	48TM501455	REV E
-----------------	------------------	------------------------	---	------------	----------

548J 08-09 UNIT DIMENSIONS (cont)

UNIT	STD. UNIT WEIGHT		CORNER WEIGHT (A)		CORNER WEIGHT (B)		CORNER WEIGHT (C)		CORNER WEIGHT (D)		C.G.		
	LBS.	KG.	LBS.	KG.	LBS.	KG.	LBS.	KG.	LBS.	KG.	X	Y	Z
548J-08D	885	401	187	85	158	72	247	112	293	133	39 15/16 [1014]	35 1/4 [895]	23 1/2 [597]
548J-09D	910	413	200	91	166	75	247	112	297	135	39 5/8 [1006]	34 1/2 [876]	23 1/2 [597]

THIS DOCUMENT IS THE PROPERTY OF CARRIER CORPORATION AND IS DELIVERED UPON THE EXPRESS CONDITION THAT THE CONTENTS WILL NOT BE DISCLOSED OR USED WITHOUT CARRIER CORPORATION'S WRITTEN CONSENT.

SUBMISSION OF THESE DRAWINGS OR DOCUMENTS DOES NOT CONSTITUTE PART PERFORMANCE OR ACCEPTANCE OF CONTRACT.

*** STANDARD UNIT WEIGHT IS WITHOUT ELECTRIC HEAT AND WITHOUT PACKAGING. FOR OTHER OPTIONS AND ACCESSORIES, REFER TO THE PRODUCT DATA CATALOG.

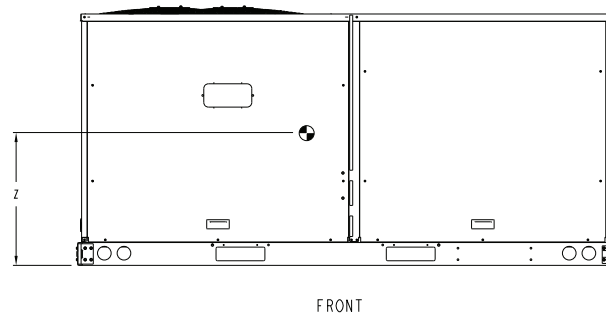
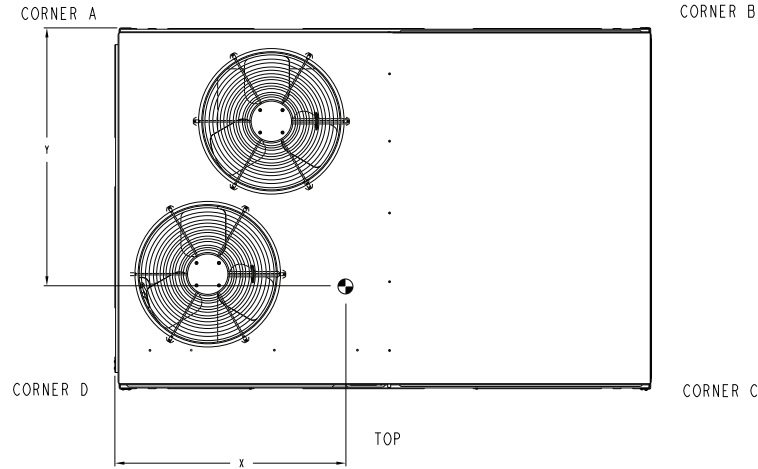

SHEET 2 OF 2	DATE 10-04-10	SUPERCEDES 03-10-09	548J 08-09 SINGLE ZONE ELECTRIC HEAT PUMP	48TM501455	REV E
-----------------	------------------	------------------------	--	------------	----------

548J 08-09 SERVICE CLEARANCES

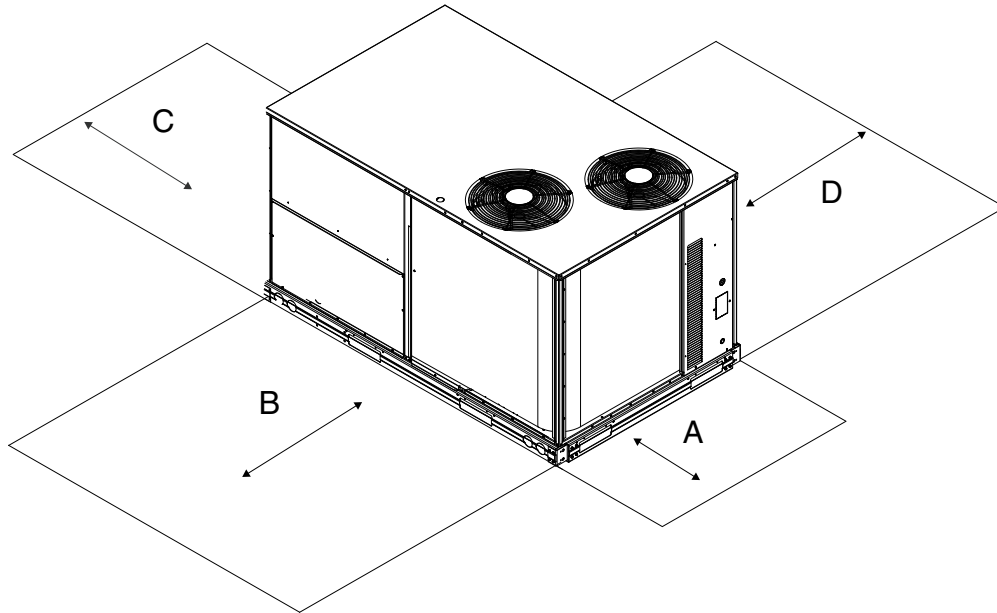

LOCATION	DIMENSION	CONDITION
A	48-in. (1219 mm)	Unit disconnect is mounted on panel
	18-in. (457 mm)	No disconnect, convenience outlet option
	18-in. (457 mm)	Recommended service clearance
	12-in. (305 mm)	Minimum clearance
B	42-in. (1067 mm)	Surface behind servicer is grounded (e.g., metal, masonry wall)
	36-in. (914 mm)	Surface behind servicer is electrically non-conductive (e.g., wood, fiberglass)
	Special	Check for sources of flue products within 10 ft (3 m) of unit fresh air intake hood
C	36-in. (914 mm)	Side condensate drain is used
	18-in. (457 mm)	Minimum clearance
D	42-in. (1067 mm)	Surface behind servicer is grounded (e.g., metal, masonry wall, another unit)
	36-in. (914 mm)	Surface behind servicer is electrically non-conductive (e.g., wood, fiberglass)

NOTE: Unit not designed to have overhead obstruction. Contact Application Engineering for guidance on any application planning overhead obstruction or for vertical clearances.

548J 12 UNIT DIMENSIONS

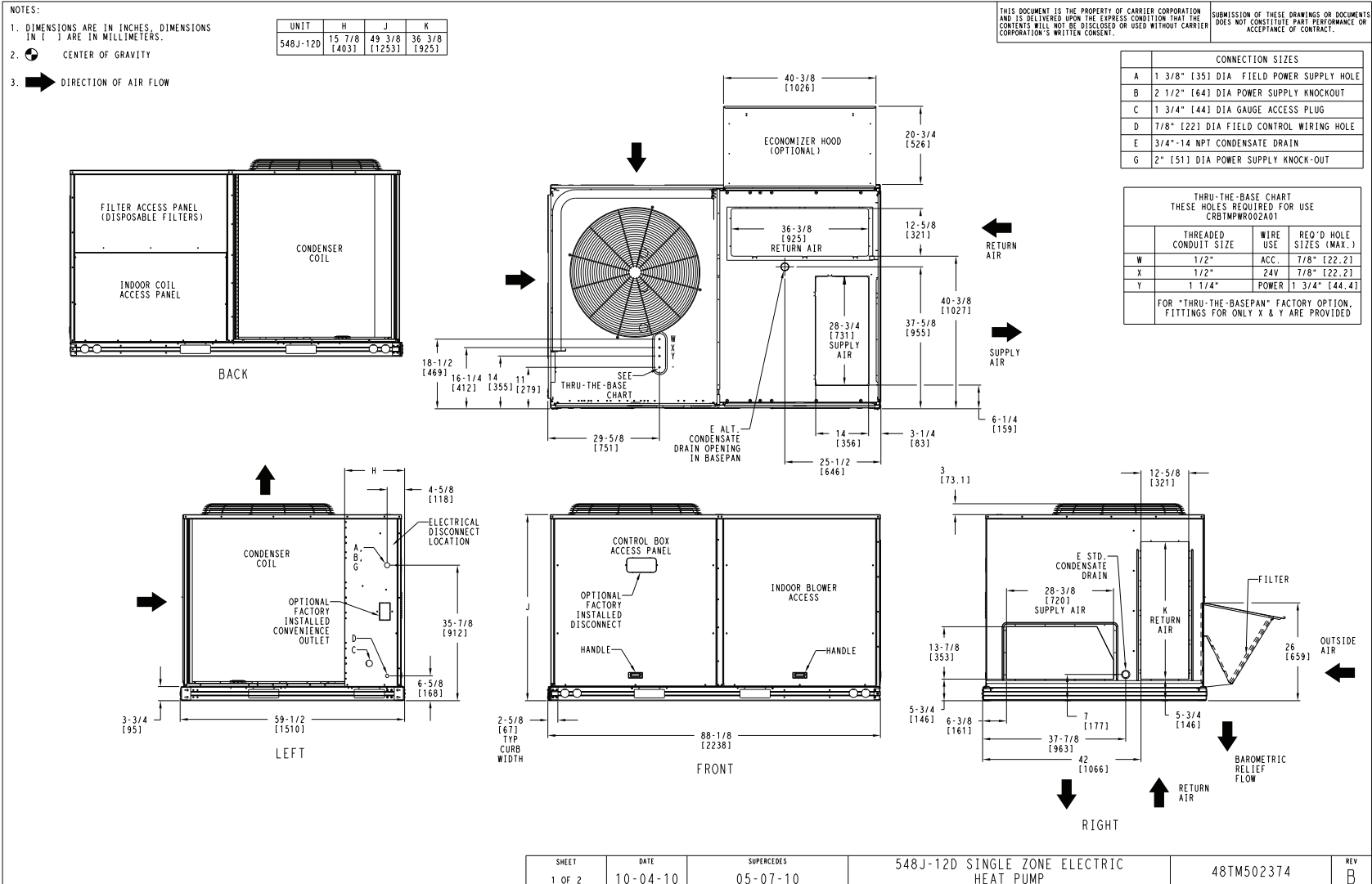

Base unit dimensions (cont)

SHEET 1 OF 2	DATE 10-04-10	SUPERCEDES 05-07-10	548J-12D SINGLE ZONE ELECTRIC HEAT PUMP	48TM502374	REV B
-----------------	------------------	------------------------	--	------------	----------

548J 12 UNIT DIMENSIONS (cont)

UNIT	STD. UNIT WEIGHT*		CORNER WEIGHT (A)		CORNER WEIGHT (B)		CORNER WEIGHT (C)		CORNER WEIGHT (D)		C. G.		
	LBS.	KG.	LBS.	KG.	LBS.	KG.	LBS.	KG.	LBS.	KG.	X	Y	Z
548J-12D	1050	476	284	129	201	91	234	106	331	150	36 1/2 (927)	32 (813)	23 1/2 (597)

THIS DOCUMENT IS THE PROPERTY OF CARRIER CORPORATION AND IS DELIVERED UPON THE EXPRESS CONDITION THAT THE CONTENTS WILL NOT BE DISCLOSED OR USED WITHOUT CARRIER CORPORATION'S WRITTEN CONSENT.

SUBMISSION OF THESE DRAWINGS OR DOCUMENTS DOES NOT CONSTITUTE PART PERFORMANCE OR ACCEPTANCE OF CONTRACT.

* STANDARD UNIT WEIGHT IS WITHOUT ELECTRIC HEAT AND WITHOUT PACKAGING.
FOR OPTIONS AND ACCESSORIES REFER TO THE PRODUCT DATA CATALOG.

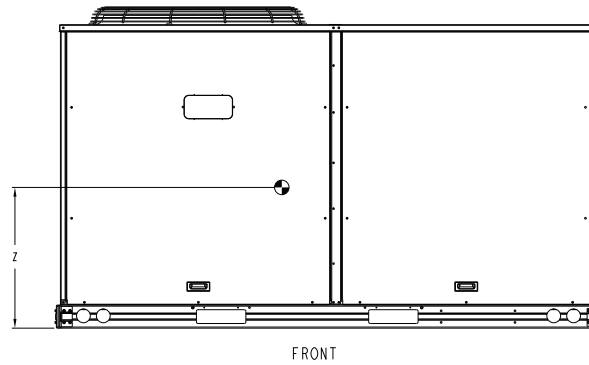
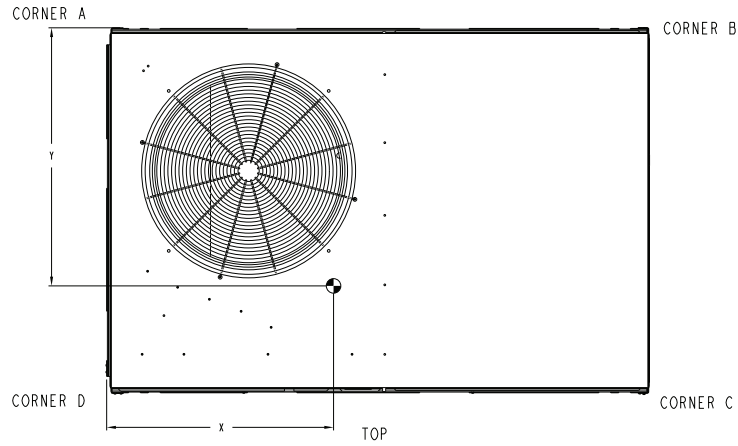

SHEET	DATE	SUPERCEDES	548J-12D SINGLE ZONE ELECTRIC HEAT PUMP	48TM502374	REV
2 OF 2	10-04-10	05-07-10			B

Base unit dimensions (cont)

548J 12 SERVICE CLEARANCES

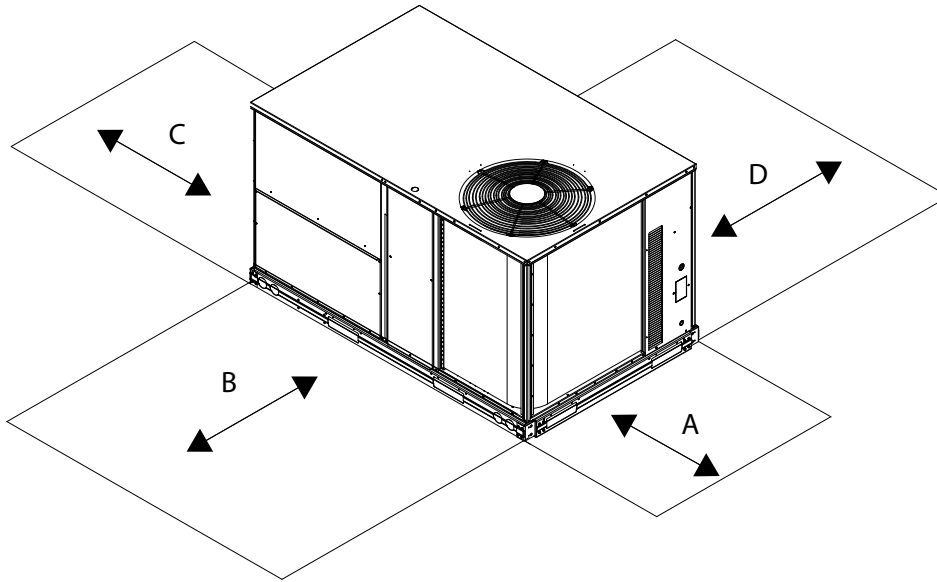

LOCATION	DIMENSION	CONDITION
A	48-in. (1219 mm)	Unit disconnect is mounted on panel
	18-in. (457 mm)	No disconnect, convenience outlet option
	18-in. (457 mm)	Recommended service clearance
	12-in. (305 mm)	Minimum clearance
B	42-in. (1067 mm)	Surface behind servicer is grounded (e.g., metal, masonry wall)
	36-in. (914 mm)	Surface behind servicer is electrically non-conductive (e.g., wood, fiberglass)
	Special	Check for sources of flue products within 10 ft (3 m) of unit fresh air intake hood
C	36-in. (914 mm)	Side condensate drain is used
	18-in. (457 mm)	Minimum clearance
D	42-in. (1067 mm)	Surface behind servicer is grounded (e.g., metal, masonry wall, another unit)
	36-in. (914 mm)	Surface behind servicer is electrically non-conductive (e.g., wood, fiberglass)

NOTE: Unit not designed to have overhead obstruction. Contact Application Engineering for guidance on any application planning overhead obstruction or for vertical clearances.

548J 14 UNIT DIMENSIONS

NOTES:

1. DIMENSIONS ARE IN INCHES, DIMENSIONS IN [] ARE IN MILLIMETERS.
2. CENTER OF GRAVITY
3. DIRECTION OF AIR FLOW

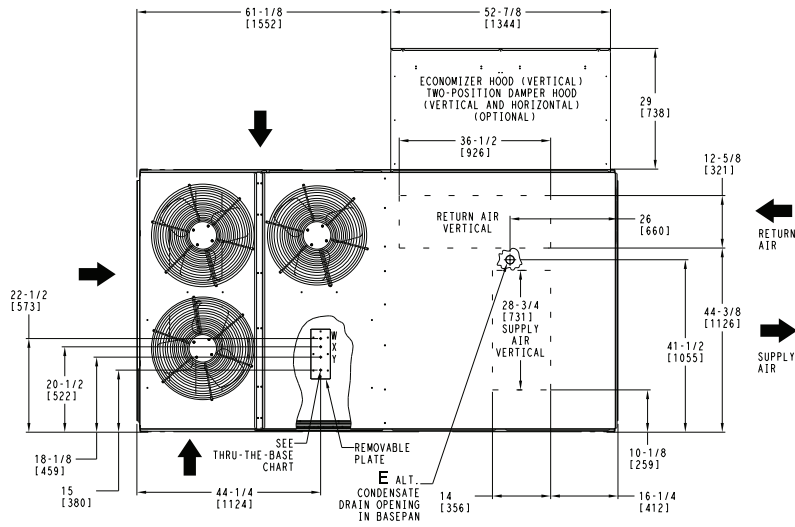
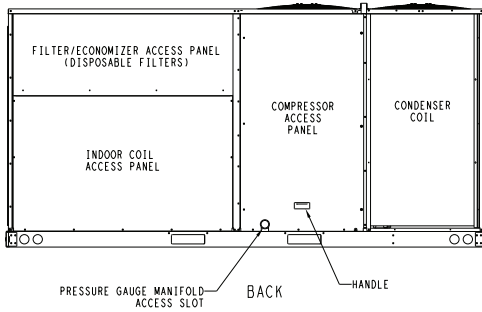

CONNECTION SIZES			
B	2 1/2" [64]	DIA POWER SUPPLY HOLE	
D	7/8" [22]	DIA FIELD CONTROL WIRING HOLE	
E	3/4"-14 NPT	CONDENSATE DRAIN	
F	7/8" [22]	DIA FIELD CONVENIENCE OUTLET HOLE	

THRU-THE-BASE CHART THESE HOLES REQUIRED FOR USE CRBTMPR003A00, 006A00, 007A00			
ACCESSORY NO.	THREADED CONDUIT SIZE	WIRE USE	REQ'D HOLE SIZES (MAX.)
005	W 1/2"	ACC.	7/8" [22.2]
	X 1/2"	24V	7/8" [22.2]
	Y 1 1/4"	POWER	1 1/2" [38.1]
006	W 1/2"	ACC.	7/8" [22.2]
	X 1 1/2"	24V	7/8" [22.2]
	Y 1 1/2"	POWER	2" [50.8]
007	W 1/2"	ACC.	7/8" [22.2]
	X 1 1/2"	24V	7/8" [22.2]
	Y 2"	POWER	2 1/2" [63.5]

FOR "THRU-THE-BASEPAN" FACTORY OPTION, FITTINGS FOR X & Y ARE PROVIDED AS SPECIFIED ON "006".

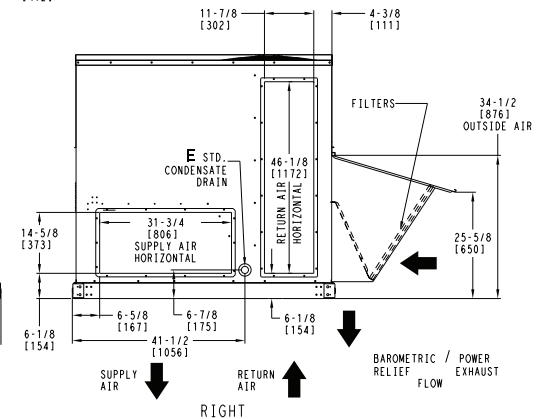
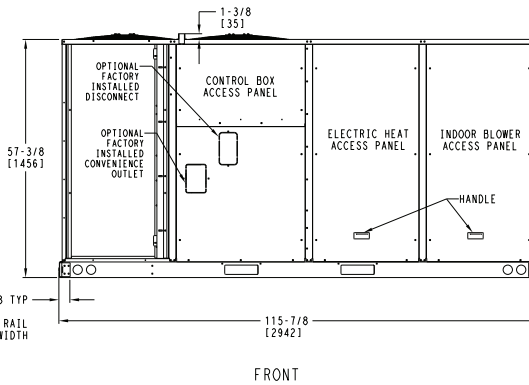
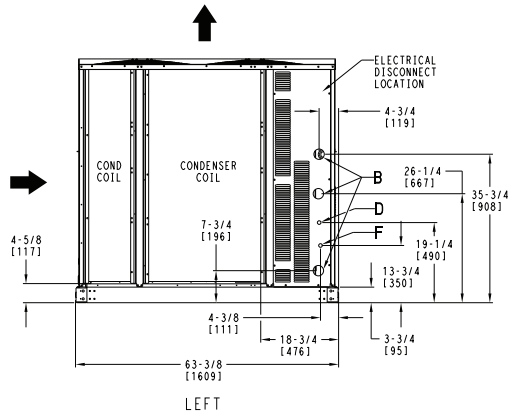

DATE	SUPERCEDES	548J 14 SINGLE ZONE ELECTRIC HEAT PUMP	50TM500766	REV
05/22/12	-			B

548J 14 UNIT DIMENSIONS (cont)

UNIT	STD UNIT WEIGHT		CORNER WEIGHT (A)		CORNER WEIGHT (B)		CORNER WEIGHT (C)		CORNER WEIGHT (D)		C.G.					
	LBS.	KG.	LBS.	KG.	LBS.	KG.	LBS.	KG.	LBS.	KG.	X	Y	Z			
548J-14	1370	623	369	168	361	164	316	144	324	147	57 1/2	[1460]	29 1/2	[750]	24	[610]

STANDARD UNIT WEIGHT IS WITHOUT ELECTRIC HEAT & WITHOUT PACKAGING. FOR OPTIONS & ACCESSORIES, REFER TO THE PRODUCT DATA CATALOG.

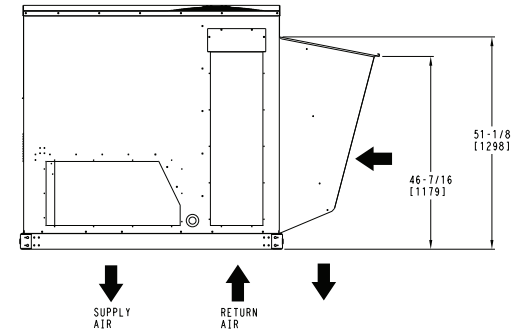
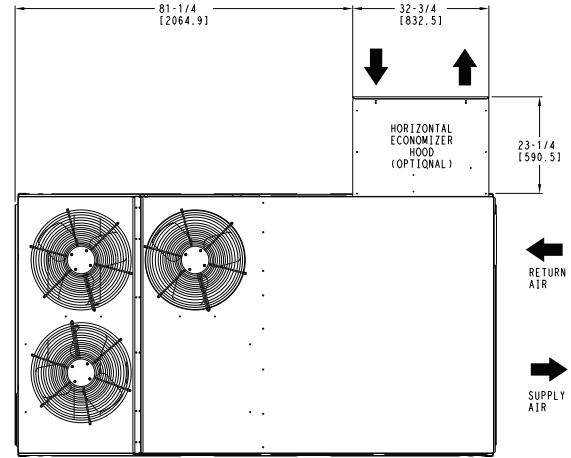
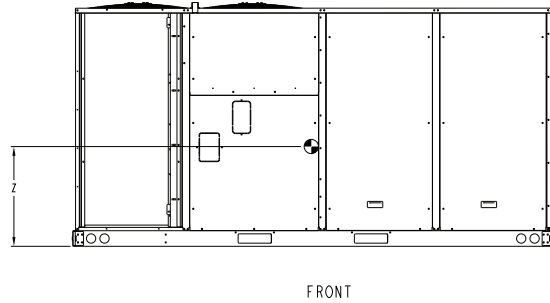
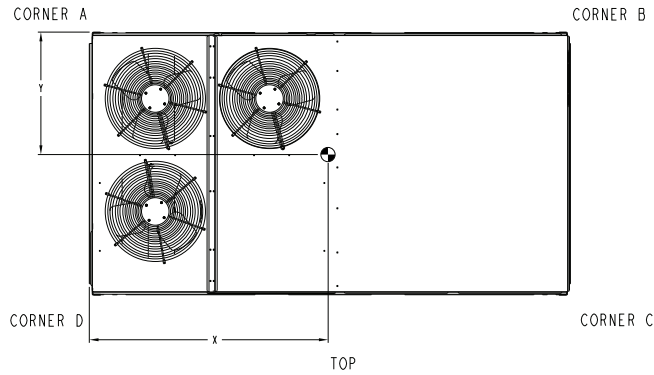

HORIZONTAL ECONOMIZER

DATE	SUPERCEDES	548J 14 SINGLE ZONE ELECTRIC HEAT PUMP	50TM500766	REV
05/22/12	-			B

548J 14 SERVICE CLEARANCES

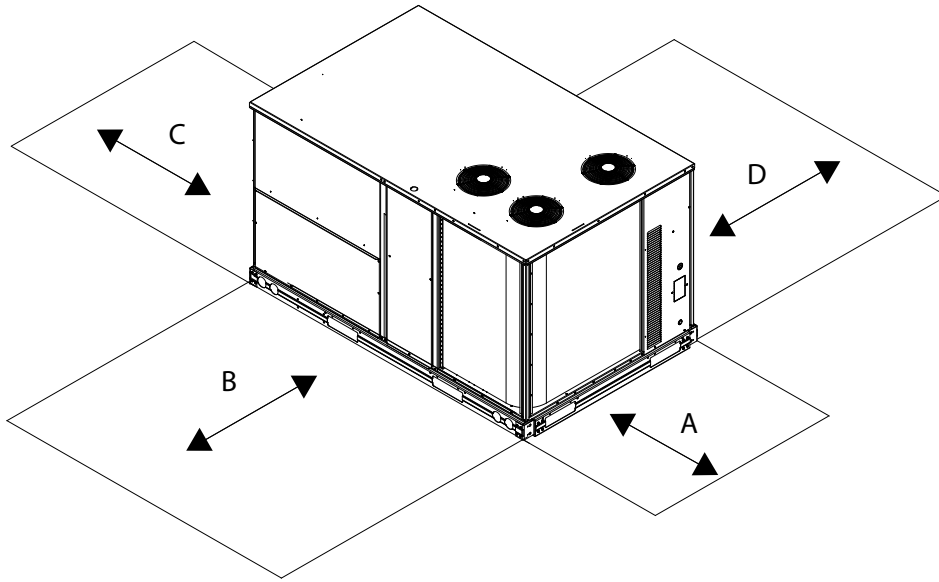

LOCATION	DIMENSION	CONDITION
A	48-in. (1219 mm)	Unit disconnect is mounted on panel
	18-in. (457 mm)	No disconnect, convenience outlet option
	18-in. (457 mm)	Recommended service clearance
	12-in. (305 mm)	Minimum clearance
B	42-in. (1067 mm)	Surface behind servicer is grounded (e.g., metal, masonry wall)
	36-in. (914 mm)	Surface behind servicer is electrically non-conductive (e.g., wood, fiberglass)
	Special	Check for sources of flue products within 10 ft (3 m) of unit fresh air intake hood
C	36-in. (914 mm)	Side condensate drain is used
	18-in. (457 mm)	Minimum clearance
D	42-in. (1067 mm)	Surface behind servicer is grounded (e.g., metal, masonry wall, another unit)
	36-in. (914 mm)	Surface behind servicer is electrically non-conductive (e.g., wood, fiberglass)

NOTE: Unit not designed to have overhead obstruction. Contact Application Engineering for guidance on any application planning overhead obstruction or for vertical clearances.

548J 07 ROOF CURB DIMENSIONS

ROOF CURB ACCESSORY #	A
CRRFCURB001A01	14" [356]
CRRFCURB002A01	24" [610]

- NOTES:
1. ROOFCURB ACCESSORY IS SHIPPED DISASSEMBLED.
 2. INSULATED PANELS: 25.4 [1"] THK. POLYURETHANE FOAM, 44.5 [1-3/4] # DENSITY.
 3. DIMENSIONS IN [] ARE IN MILLIMETERS.
 4. ROOFCURB: 18 GAGE STEEL.
 5. ATTACH DUCTWORK TO CURB. (FLANGES OF DUCT REST ON CURB).
 6. SERVICE CLEARANCE 4 FEET ON EACH SIDE.
 7. DIRECTION OF AIR FLOW.
 8. CONNECTOR PACKAGE CRBTMPWR001A01 IS FOR THRU-THE-CURB GAS TYPE PACKAGE CRBTMPWR003A01 IS FOR THRU-THE-BOTTOM TYPE GAS CONNECTIONS.

CONNECTOR PKG. ACC.	GAS CONNECTION TYPE	GAS FITTING	POWER WIRING FITTING	CONTROL WIRING FITTING	ACCESSORY CONVENIENCE OUTLET WIRING CONNECTOR
CRBTMPWR001A01	THRU THE CURB	3/4" [19] NPT	3/4" [19] NPT	1/2" [12.7] NPT	1/2" [12.7] NPT
CRBTMPWR003A01	THRU THE BOTTOM	1/2" [12.7] NPT			

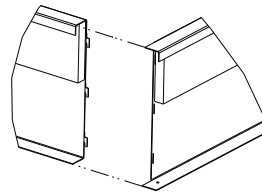
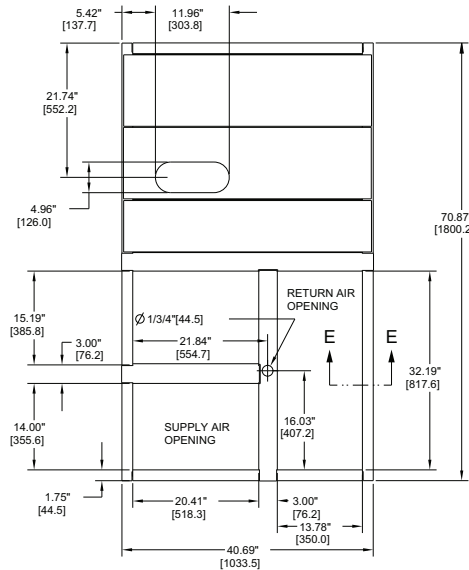

VIEW "B"
CORNER DETAIL

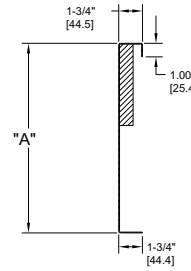
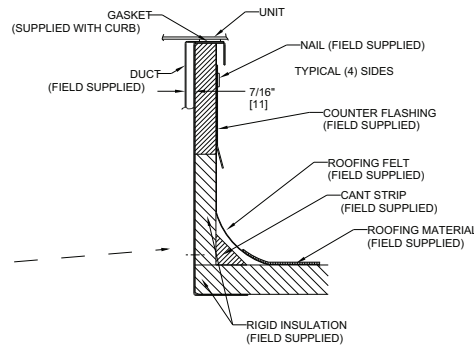

SECTION E-E
SCALE 0.250

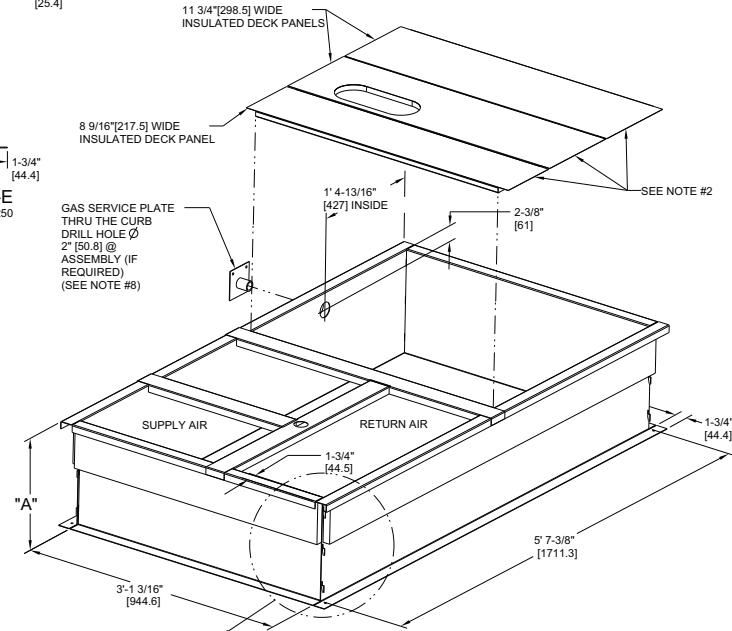

CERTIFIED DRAWING

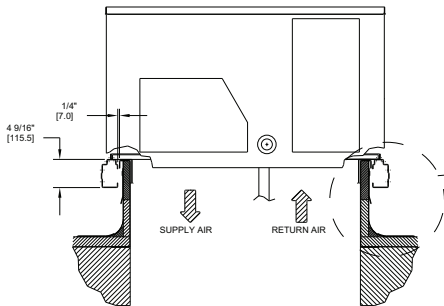

A	OVERALL DIM. 5'-7 3/8" WAS 5'-7 7/8: 18GA MATERIAL WA 16 GA.; NAIL FIELD SUPPLIED WAS WITH CURB	04/22/13	MMC	-	-	1067898
REV	REVISION RECORD	DATE	BY	CHKD	APPD	ECN NO.

DRAWING RELEASE LEVEL: PRODUCTION		UNLESS OTHERWISE SPECIFIED DIMENSIONS ARE IN INCHES TOLERANCES ON:		TITLE	
THIRD ANGLE PROJECTION		1 DEC ±	2 DEC ±	3 DEC ±	ANG ±
MATERIAL	-	AUTHORIZATION NUMBER			CURB ASY, ROOF
ENGINEERING REQUIREMENTS	T-005, Y-002	1041738			
WEIGHT:	-	ENGINEERING	MANUFACTURING	SIZE	DRAWING NUMBER
SURFACE FINISH	-	MMC	06/17/11	D	48TC400427
MODEL (INTERNAL USE ONLY)	-	DRAFTER		CHECKER	REV
PURCH	-	D		B	SHEET 5 OF 5
NEXT DRAWING		SCALE	DISTRIBUTION		
-		N/A	MMC		

548J 08-12 ROOF CURB DIMENSIONS

ROOF CURB ACCESSORY #	A
CRRFCURB003A01	14" [356]
CRRFCURB004A01	24" [610]

- NOTES:
 1. ROOFCURB ACCESSORY IS SHIPPED DISASSEMBLED.
 2. INSULATED PANELS: 25.4 [1"] THK. POLYURETHANE FOAM, 44.5 [1-3/4] # DENSITY.
 3. DIMENSIONS IN [] ARE IN MILLIMETERS.
 4. ROOFCURB: 18 GAGE STEEL.
 5. ATTACH DUCTWORK TO CURB. (FLANGES OF DUCT REST ON CURB).
 6. SERVICE CLEARANCE 4 FEET ON EACH SIDE.
 7. DIRECTION OF AIR FLOW.
 8. CONNECTOR PACKAGE CRBTMPWR002A01 IS FOR THRU-THE-CURB GAS TYPE PACKAGE CRBTMPWR004A01 IS FOR THRU-THE-BOTTOM TYPE GAS CONNECTIONS.

CONNECTOR PKG. ACC.	GAS CONNECTION TYPE	GAS FITTING	POWER WIRING FITTING	CONTROL WIRING FITTING	ACCESSORY CONVENIENCE OUTLET WIRING CONNECTOR
CRBTMPWR002A01	THRU THE CURB	3/4" [19] NPT	1 1/4" [31.7] NPT	1/2" [12.7] NPT	1/2" [12.7] NPT
CRBTMPWR004A01	THRU THE BOTTOM				

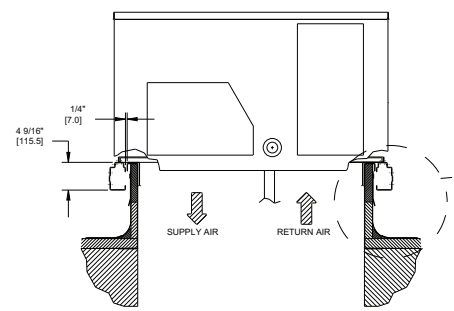
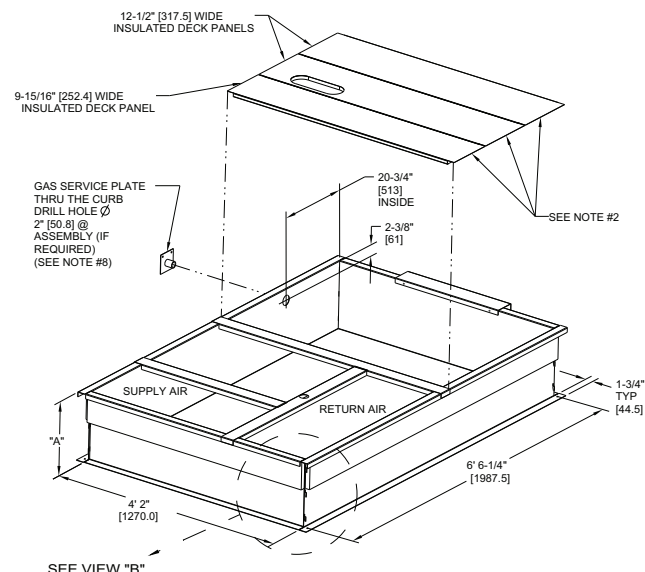
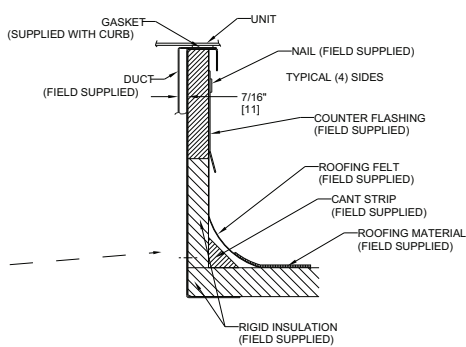
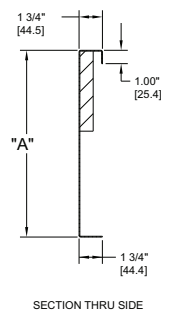
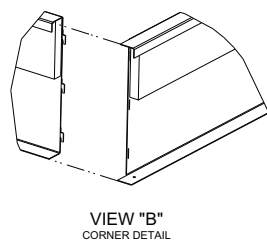
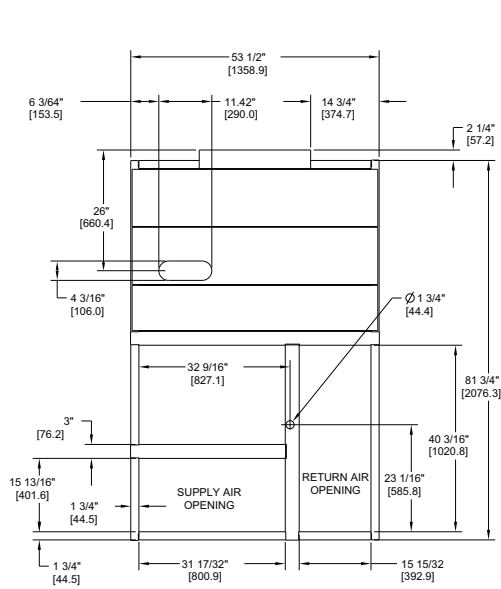

CERTIFIED DRAWING

C	6' 6 1/4" WAS 6' 7 1/8", 4"2" WAS 4' 2 13/16", 18 GA WAS 16 GA., 15 13/16" WAS 15 15/16", NAIL FIELD SUPPLIED WAS WITH CURB	4/22/13	MMC	-	-	1067898
REV	REVISION RECORD	DATE	BY	CHKD	APPD	ECN NO.

DRAWING RELEASE LEVEL:		PRODUCTION			
THIRD ANGLE PROJECTION		UNLESS OTHERWISE SPECIFIED DIMENSIONS ARE IN INCHES		THIS DOCUMENT AND THE INFORMATION CONTAINED THEREIN IS PROPRIETARY TO CARRIER CORPORATION AND SHALL NOT BE USED OR DISCLOSED TO OTHERS, IN WHOLE OR IN PART, WITHOUT THE WRITTEN AUTHORIZATION OF CARRIER CORPORATION.	
MATERIAL	-	TOLERANCES ON:		TITLE	
	-	1 DEC	2 DEC	3 DEC	ANG
	-	±	±	±	±
ENGINEERING REQUIREMENTS	T-005, Y-002	AUTHORIZATION NUMBER		CURB ASY, ROOF	
WEIGHT:	-	ENGINEERING	MANUFACTURING	SIZE	DRAWING NUMBER
SURFACE FINISH	-	1029120		D	50HJ405012
	-	DRAFTER	CHECKER	SHEET 5 OF 5	REV
	-	MMC	12/16/09		C
	-	MODEL (INTERNAL USE ONLY)		NEXT DRAWING	SCALE
	-			-	N/A
	-			DISTRIBUTION	
	-			-	-

548J 14 ROOF CURB DIMENSIONS

ROOF CURB ACCESSORY #	A
CRRFCURB074A00	14" [356]
CRRFCURB075A00	24" [610]

- NOTES:
1. ROOFCURB ACCESSORY IS SHIPPED DISASSEMBLED.
 2. INSULATED PANELS: 1/2" THK. NEOPRENE FOAM, 1.0# DENSITY.
 3. DIMENSIONS IN () ARE IN MILLIMETERS.
 4. ROOFCURB SIDEWALLS: 16 GAGE STEEL.
 5. ATTACH DUCTWORK TO CURB, (FLANGES OF DUCT REST ON CURB).
 6. SERVICE CLEARANCE 4 FT ON EACH SIDE.
 7. DIRECTION OF AIR FLOW.
 8. "L" & "S" DESIGNATIONS DENOTE LOCATION OF COMMON CROSS RAIL. (POSITION "L" FOR LARGE DUCT OPENING CURB).

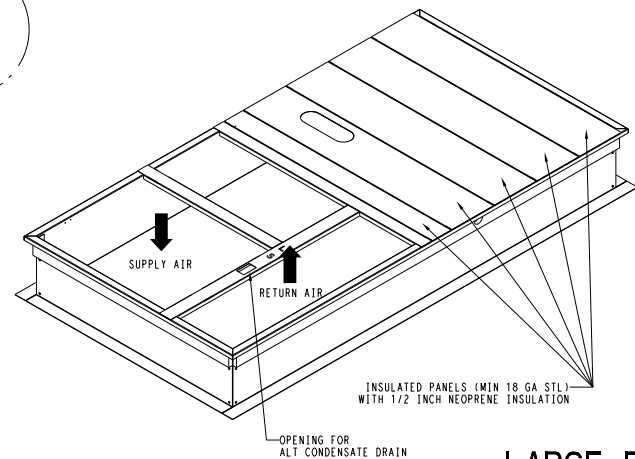
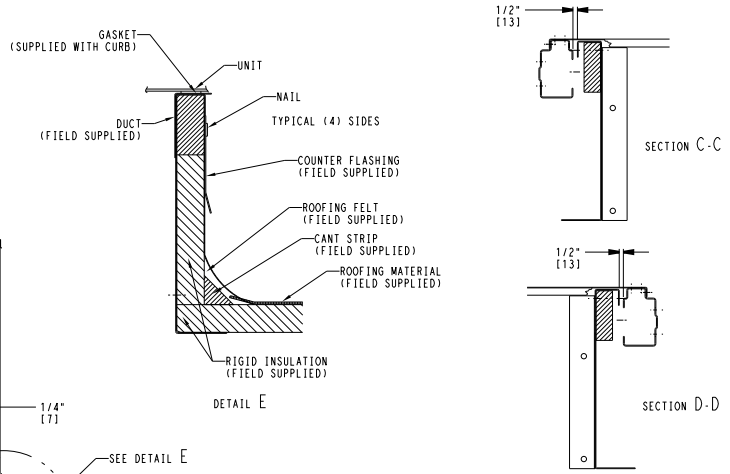
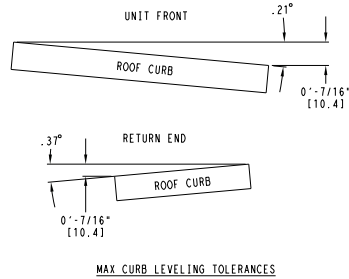
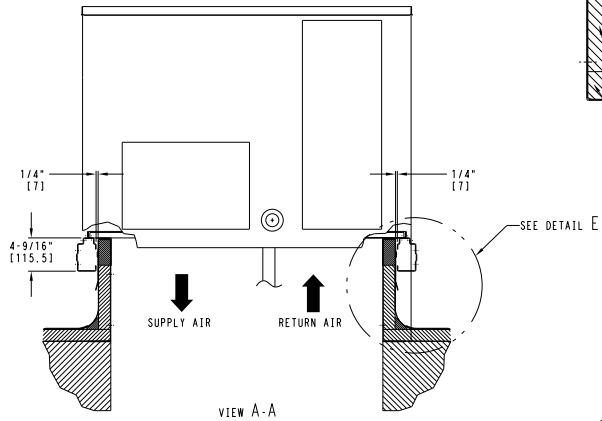
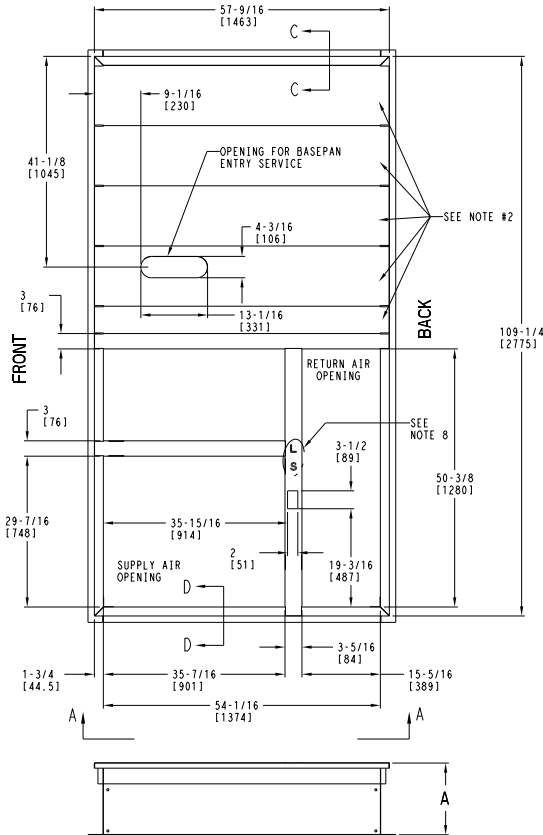

LARGE DUCT OPENINGS

Performance data

548J 07 COOLING CAPACITY

			AMBIENT TEMPERATURE (F)												
			85			95			105			115			
			EA (db)			EA (db)			EA (db)			EA (db)			
			75	80	85	75	80	85	75	80	85	75	80	85	
1800 Cfm	EA (wb)	58	TC	61.1	61.1	68.9	58.3	58.3	66.1	55.2	55.2	63.2	51.8	51.8	59.9
			SHC	53.3	61.1	68.9	50.4	58.3	66.1	47.2	55.2	63.2	43.7	51.8	59.9
		62	TC	64.1	64.1	65.2	60.5	60.5	63.6	56.5	56.5	61.8	52.1	52.1	59.7
			SHC	49.6	57.4	65.2	47.8	55.7	63.6	45.8	53.8	61.8	43.4	51.6	59.7
		67	TC	70.8	70.8	70.8	67.2	67.2	67.2	63.1	63.1	63.1	58.6	58.6	58.6
			SHC	40.7	48.5	56.3	39.1	47.0	54.9	37.3	45.3	53.3	35.3	43.5	51.7
		72	TC	77.4	77.4	77.4	73.7	73.7	73.7	69.5	69.5	69.5	64.9	64.9	64.9
			SHC	31.1	38.9	46.7	29.6	37.5	45.5	27.9	36.0	44.0	26.0	34.2	42.5
76	TC	—	82.0	82.0	—	78.4	78.4	—	73.9	73.9	—	68.8	68.8		
	SHC	—	30.9	38.8	—	29.7	37.6	—	28.1	36.2	—	26.4	34.6		
2100 Cfm	EA (wb)	58	TC	64.6	64.6	73.7	61.6	61.6	70.8	58.4	58.4	67.7	54.8	54.8	64.3
			SHC	55.5	64.6	73.7	52.5	61.6	70.8	49.1	58.4	67.7	45.3	54.8	64.3
		62	TC	66.1	66.1	71.7	62.5	62.5	69.9	58.5	58.5	67.8	54.9	54.9	64.4
			SHC	53.4	62.5	71.7	51.5	60.7	69.9	49.2	58.5	67.8	45.3	54.9	64.4
		67	TC	72.8	72.8	72.8	69.0	69.0	69.0	64.8	64.8	64.8	60.2	60.2	60.2
			SHC	43.1	52.2	61.3	41.5	50.7	59.9	39.7	49.1	58.4	37.7	47.3	56.8
		72	TC	79.2	79.2	79.2	75.4	75.4	75.4	71.0	71.0	71.0	66.2	66.2	66.2
			SHC	31.9	41.1	50.2	30.5	39.7	49.0	28.7	38.1	47.5	26.7	36.3	45.9
76	TC	—	83.1	83.1	—	79.8	79.8	—	75.1	75.1	—	69.7	69.7		
	SHC	—	32.0	41.2	—	30.7	39.9	—	29.1	38.5	—	27.3	36.9		
2400 Cfm	EA (wb)	58	TC	67.4	67.4	77.8	64.4	64.4	74.9	61.0	61.0	71.7	57.3	57.3	68.2
			SHC	57.0	67.4	77.8	53.9	64.4	74.9	50.3	61.0	71.7	46.4	57.3	68.2
		62	TC	67.8	67.8	77.4	64.4	64.4	74.9	61.0	61.0	71.7	57.3	57.3	68.3
			SHC	56.5	66.9	77.4	53.9	64.4	74.9	50.3	61.0	71.7	46.4	57.3	68.3
		67	TC	74.3	74.3	74.3	70.4	70.4	70.4	66.1	66.1	66.1	61.4	61.4	61.7
			SHC	45.3	55.7	66.1	43.7	54.2	64.7	41.9	52.6	63.3	39.9	50.8	61.7
		72	TC	80.4	80.4	80.4	76.6	76.6	76.6	72.1	72.1	72.1	67.1	67.1	67.1
			SHC	32.6	43.0	53.4	31.2	41.7	52.3	29.3	40.1	50.8	27.2	38.2	49.2
76	TC	—	84.0	84.0	—	80.7	80.7	—	76.0	76.0	—	70.4	70.4		
	SHC	—	32.6	43.1	—	31.6	42.2	—	30.0	40.8	—	28.1	39.1		
2700 Cfm	EA (wb)	58	TC	69.7	69.7	81.5	66.6	66.6	78.5	63.1	63.1	75.2	59.3	59.3	71.6
			SHC	58.0	69.7	81.5	54.8	66.6	78.5	51.1	63.1	75.2	47.0	59.3	71.6
		62	TC	69.8	69.8	81.5	66.6	66.6	78.4	63.2	63.2	75.2	59.4	59.4	71.7
			SHC	58.0	69.8	81.5	54.8	66.6	78.4	51.2	63.2	75.2	47.1	59.4	71.7
		67	TC	75.4	75.4	75.4	71.4	71.4	71.4	67.1	67.1	67.9	62.3	62.3	66.4
			SHC	47.2	59.0	70.7	45.7	57.6	69.4	43.9	55.9	67.9	41.8	54.1	66.4
		72	TC	81.3	81.3	81.3	77.5	77.5	77.5	72.9	72.9	72.9	67.8	67.8	67.8
			SHC	33.0	44.8	56.5	31.7	43.6	55.5	29.8	41.9	54.0	27.7	40.0	52.4
76	TC	—	84.9	84.9	—	81.3	81.3	—	76.6	76.6	—	70.8	70.8		
	SHC	—	33.4	45.2	—	33.0	44.9	—	30.8	43.0	—	28.8	41.3		
3000 Cfm	EA (wb)	58	TC	71.7	71.7	84.7	68.5	68.5	81.7	64.9	64.9	78.3	61.0	61.0	74.7
			SHC	58.7	71.7	84.7	55.4	68.5	81.7	51.6	64.9	78.3	47.3	61.0	74.7
		62	TC	71.7	71.7	84.8	68.6	68.6	81.7	65.0	65.0	78.3	61.0	61.0	74.7
			SHC	58.7	71.7	84.8	55.4	68.6	81.7	51.6	65.0	78.3	47.4	61.0	74.7
		67	TC	76.4	76.4	76.4	72.3	72.3	73.8	67.9	67.9	72.4	63.0	63.0	70.8
			SHC	49.0	62.1	75.1	47.5	60.7	73.8	45.7	59.0	72.4	43.4	57.1	70.8
		72	TC	82.0	82.0	82.0	78.2	78.2	78.2	73.5	73.5	73.5	68.2	68.2	68.2
			SHC	33.4	46.5	59.5	32.1	45.3	58.5	30.2	43.6	57.1	28.0	41.7	55.5
76	TC	—	85.5	85.5	—	81.8	81.8	—	77.1	77.1	—	71.3	71.3		
	SHC	—	34.2	47.2	—	33.0	46.3	—	31.6	45.1	—	29.5	43.3		

LEGEND

—	Do not operate in this region
Cfm	Cubic feet per minute (supply air)
EAT (db)	Entering air temperature (dry bulb)
EAT (wb)	Entering air temperature (wet bulb)
SHC	Sensible heat capacity (1000 Btuh) Gross
TC	Total capacity (1000 Btuh) Gross

Performance data (cont)

548J 08 COOLING CAPACITY

				AMBIENT TEMPERATURE (F)												
				85			95			105			115			
				EA (db)			EA (db)			EA (db)			EA (db)			
				75	80	85	75	80	85	75	80	85	75	80	85	
2250 Cfm	EA (wb)	58	TC	77.4	77.4	87.8	74.1	74.1	84.1	69.8	69.8	79.2	65.2	65.2	74.1	
			SHC	66.9	77.4	87.8	64.0	74.1	84.1	60.3	69.8	79.2	56.4	65.2	74.1	
		62	TC	81.8	81.8	83.7	77.2	77.2	81.4	71.9	71.9	78.9	66.6	66.6	75.9	
			SHC	60.6	72.1	83.7	58.4	69.9	81.4	55.9	67.4	78.9	53.2	64.5	75.9	
		67	TC	90.6	90.6	90.6	86.0	86.0	86.0	80.8	80.8	80.8	75.1	75.1	75.1	
			SHC	50.4	62.0	73.5	48.4	60.0	71.6	46.2	57.8	69.3	43.9	55.4	67.0	
	72	TC	99.4	99.4	99.4	94.7	94.7	94.7	89.5	89.5	89.5	83.8	83.8	83.8		
		SHC	39.6	51.3	62.9	37.7	49.4	61.0	35.8	47.4	59.0	33.6	45.2	56.8		
	76	TC	—	105.7	105.7	—	100.8	100.8	—	95.5	95.5	—	89.7	89.7		
		SHC	—	42.1	54.5	—	40.4	52.8	—	38.6	50.9	—	36.5	48.8		
	2625 Cfm	EA (wb)	58	TC	81.8	81.8	92.8	78.0	78.0	88.6	74.1	74.1	84.2	69.5	69.5	78.9
				SHC	70.7	81.8	92.8	67.5	78.0	88.6	64.1	74.1	84.2	60.1	69.5	78.9
62			TC	84.7	84.7	91.7	79.9	79.9	89.2	75.2	75.2	86.2	69.8	69.8	81.6	
			SHC	65.2	78.5	91.7	62.9	76.1	89.2	60.3	73.3	86.2	56.8	69.2	81.6	
67			TC	93.4	93.4	93.4	88.6	88.6	88.6	83.2	83.2	83.2	77.4	77.4	77.4	
			SHC	53.4	66.7	80.1	51.4	64.7	78.1	49.2	62.5	75.9	46.8	60.2	73.5	
72		TC	101.9	101.9	101.9	97.1	97.1	97.1	91.8	91.8	91.8	86.0	86.0	86.0		
		SHC	40.8	54.1	67.5	38.9	52.3	65.6	36.9	50.3	63.6	34.8	48.1	61.5		
76		TC	—	107.7	107.7	—	102.6	102.6	—	97.2	97.2	—	91.2	91.2		
		SHC	—	43.7	58.1	—	41.9	56.0	—	39.9	53.9	—	37.9	51.6		
3000 Cfm		EA (wb)	58	TC	85.6	85.6	97.2	81.8	81.8	92.9	77.6	77.6	88.0	72.9	72.9	82.8
				SHC	74.1	85.6	97.2	70.7	81.8	92.9	67.1	77.6	88.0	63.0	72.9	82.8
	62		TC	87.0	87.0	98.9	82.5	82.5	95.4	78.0	78.0	90.5	73.3	73.3	85.6	
			SHC	69.4	84.1	98.9	66.6	81.0	95.4	63.1	76.8	90.5	59.6	72.6	85.6	
	67		TC	95.5	95.5	95.5	90.5	90.5	90.5	85.1	85.1	85.1	79.0	79.0	79.6	
			SHC	56.1	71.2	86.2	54.1	69.2	84.2	51.9	67.0	82.1	49.5	64.6	79.6	
	72	TC	103.8	103.8	103.8	98.8	98.8	98.8	93.4	93.4	93.4	87.5	87.5	87.5		
		SHC	41.8	56.7	71.6	39.9	54.8	69.8	37.9	52.9	67.8	35.8	50.7	65.7		
	76	TC	—	109.1	109.1	—	104.0	104.0	—	98.3	98.3	—	92.2	92.2		
		SHC	—	44.9	60.6	—	43.1	58.6	—	41.1	56.4	—	39.0	54.2		
	3375 Cfm	EA (wb)	58	TC	88.9	88.9	100.9	84.9	84.9	96.4	80.5	80.5	91.4	75.7	75.7	86.0
				SHC	76.9	88.9	100.9	73.4	84.9	96.4	69.6	80.5	91.4	65.5	75.7	86.0
62			TC	89.6	89.6	103.8	85.1	85.1	100.4	81.0	81.0	94.1	75.8	75.8	89.5	
			SHC	72.4	88.1	103.8	69.7	85.0	100.4	65.6	79.8	94.1	62.1	75.8	89.5	
67			TC	97.1	97.1	97.1	92.1	92.1	92.1	86.5	86.5	87.9	80.3	80.3	85.4	
			SHC	58.7	75.3	92.0	56.7	73.4	90.1	54.5	71.2	87.9	52.0	68.7	85.4	
72		TC	105.2	105.2	105.2	100.0	100.0	100.0	94.5	94.5	94.5	88.5	88.5	88.5		
		SHC	42.6	59.0	75.3	40.7	57.1	73.5	38.8	55.2	71.6	36.6	53.1	69.5		
76		TC	—	110.1	110.1	—	105.0	105.0	—	99.2	99.2	—	92.9	92.9		
		SHC	—	45.9	62.8	—	44.1	60.9	—	42.1	58.7	—	40.0	56.4		
3750 Cfm		EA (wb)	58	TC	91.6	91.6	104.0	87.5	87.5	99.4	83.0	83.0	94.3	78.1	78.1	88.7
				SHC	79.2	91.6	104.0	75.7	87.5	99.4	71.8	83.0	94.3	67.6	78.1	88.7
	62		TC	91.7	91.7	108.3	87.7	87.7	103.5	83.1	83.1	98.1	78.2	78.2	92.3	
			SHC	75.2	91.7	108.3	71.8	87.7	103.5	68.1	83.1	98.1	64.1	78.2	92.3	
	67		TC	98.4	98.4	98.4	93.3	93.3	95.6	87.7	87.7	93.4	81.5	81.5	90.9	
			SHC	61.1	79.3	97.5	59.1	77.3	95.6	56.9	75.2	93.4	54.5	72.7	90.9	
	72	TC	106.2	106.2	106.2	101.0	101.0	101.0	95.4	95.4	95.4	89.3	89.3	89.3		
		SHC	43.4	61.1	78.8	41.5	59.2	76.9	39.5	57.3	75.0	37.4	55.2	73.0		
	76	TC	—	111.0	111.0	—	105.8	105.8	—	99.8	99.8	—	93.5	93.5		
		SHC	—	46.8	64.9	—	45.1	63.1	—	43.0	60.8	—	40.9	58.4		

LEGEND

—	Do not operate in this region
Cfm	Cubic feet per minute (supply air)
EAT (db)	Entering air temperature (dry bulb)
EAT (wb)	Entering air temperature (wet bulb)
SHC	Sensible heat capacity (1000 Btuh) Gross
TC	Total capacity (1000 Btuh) Gross

548J 09 COOLING CAPACITY

			AMBIENT TEMPERATURE (F)													
			85			95			105			115				
			EA (db)			EA (db)			EA (db)			EA (db)				
			75	80	85	75	80	85	75	80	85	75	80	85		
2550 Cfm	EA (wb)	58	TC	91.1	91.1	102.9	86.4	86.4	97.5	81.2	81.2	91.7	75.7	75.7	85.5	
			SHC	79.4	91.1	102.9	75.2	86.4	97.5	70.8	81.2	91.7	66.0	75.7	85.5	
		62	TC	96.0	96.0	99.4	89.2	89.2	96.4	83.0	83.0	93.4	76.5	76.5	88.0	
			SHC	72.7	86.0	99.4	69.6	83.0	96.4	66.7	80.0	93.4	62.4	75.2	88.0	
		67	TC	106.4	106.4	106.4	100.4	100.4	100.4	92.9	92.9	92.9	86.0	86.0	86.0	
			SHC	60.4	73.8	87.2	57.7	71.1	84.5	54.7	68.1	81.6	51.8	65.2	78.6	
	72	TC	117.3	117.3	117.3	111.2	111.2	111.2	104.3	104.3	104.3	97.0	97.0	97.0		
		SHC	47.4	60.9	74.4	45.1	58.5	72.0	42.4	55.9	69.4	39.7	53.1	66.6		
	76	TC	—	126.1	126.1	—	119.9	119.9	—	113.0	113.0	—	105.6	105.6		
		SHC	—	50.3	64.3	—	48.0	61.8	—	45.6	59.4	—	43.0	56.7		
	2975 Cfm	EA (wb)	58	TC	96.5	96.5	109.0	91.7	91.7	103.5	86.7	86.7	97.9	80.5	80.5	90.9
				SHC	84.1	96.5	109.0	79.9	91.7	103.5	75.5	86.7	97.9	70.1	80.5	90.9
62			TC	98.2	98.2	109.0	92.9	92.9	105.4	87.0	87.0	100.5	80.6	80.6	94.5	
			SHC	78.1	93.6	109.0	75.1	90.2	105.4	71.3	85.9	100.5	66.7	80.6	94.5	
67			TC	109.5	109.5	109.5	103.0	103.0	103.0	96.3	96.3	96.3	87.6	87.6	87.6	
			SHC	64.1	79.6	95.2	61.4	76.9	92.5	58.7	74.3	89.8	55.3	70.9	86.5	
72		TC	120.6	120.6	120.6	114.2	114.2	114.2	107.3	107.3	107.3	99.5	99.5	99.5		
		SHC	49.1	64.7	80.3	46.7	62.3	77.9	44.1	59.7	75.3	41.3	56.9	72.5		
76		TC	—	129.2	129.2	—	122.9	122.9	—	115.7	115.7	—	108.1	108.1		
		SHC	—	52.3	68.4	—	50.0	65.8	—	47.6	63.5	—	45.0	60.8		
3400 Cfm		EA (wb)	58	TC	101.0	101.0	114.0	96.7	96.7	109.1	90.9	90.9	102.6	84.9	84.9	95.8
				SHC	88.0	101.0	114.0	84.2	96.7	109.1	79.2	90.9	102.6	74.0	84.9	95.8
	62		TC	102.3	102.3	116.5	96.9	96.9	112.5	90.7	90.7	106.3	84.6	84.6	99.1	
			SHC	82.9	99.7	116.5	79.7	96.1	112.5	75.1	90.7	106.3	70.0	84.6	99.1	
	67		TC	112.1	112.1	112.1	105.5	105.5	105.5	98.4	98.4	98.4	90.8	90.8	94.2	
			SHC	67.7	85.3	102.9	65.1	82.7	100.2	62.2	79.8	97.3	59.2	76.7	94.2	
	72	TC	123.0	123.0	123.0	116.5	116.5	116.5	109.4	109.4	109.4	101.6	101.6	101.6		
		SHC	50.5	68.2	85.9	48.2	65.8	83.5	45.6	63.2	80.8	42.8	60.4	78.1		
	76	TC	—	131.5	131.5	—	124.9	124.9	—	117.7	117.7	—	109.9	109.9		
		SHC	—	54.1	72.1	—	51.8	69.7	—	49.4	67.2	—	46.8	64.6		
	3825 Cfm	EA (wb)	58	TC	104.5	104.5	118.0	99.8	99.8	112.6	94.4	94.4	106.6	87.9	87.9	99.2
				SHC	91.1	104.5	118.0	86.9	99.8	112.6	82.3	94.4	106.6	76.6	87.9	99.2
62			TC	105.0	105.0	123.0	100.3	100.3	117.5	93.4	93.4	109.5	87.3	87.3	102.3	
			SHC	86.9	105.0	123.0	83.0	100.3	117.5	77.4	93.4	109.5	72.3	87.3	102.3	
67			TC	114.1	114.1	114.1	107.4	107.4	107.6	99.4	99.4	104.6	92.0	92.0	101.3	
			SHC	71.2	90.8	110.4	68.5	88.1	107.6	65.4	85.0	104.6	62.4	81.9	101.3	
72		TC	124.9	124.9	124.9	118.2	118.2	118.2	111.0	111.0	111.0	103.1	103.1	103.1		
		SHC	51.9	71.5	91.1	49.5	69.1	88.7	47.0	66.6	86.2	44.2	63.8	83.4		
76		TC	—	133.3	133.3	—	126.5	126.5	—	119.2	119.2	—	111.2	111.2		
		SHC	—	55.7	75.6	—	53.5	73.3	—	51.1	70.8	—	48.5	68.1		
4250 Cfm		EA (wb)	58	TC	108.6	108.6	122.6	102.7	102.7	115.9	97.4	97.4	110.0	90.8	90.8	102.5
				SHC	94.6	108.6	122.6	89.5	102.7	115.9	84.9	97.4	110.0	79.1	90.8	102.5
	62		TC	109.0	109.0	126.4	103.4	103.4	121.2	97.5	97.5	114.2	91.3	91.3	106.9	
			SHC	89.5	107.9	126.4	85.6	103.4	121.2	80.7	97.5	114.2	75.6	91.3	106.9	
	67		TC	115.6	115.6	117.4	108.9	108.9	114.7	101.6	101.6	111.4	93.6	93.6	108.1	
			SHC	74.3	95.9	117.4	71.7	93.2	114.7	68.7	90.1	111.4	65.6	86.8	108.1	
	72	TC	126.4	126.4	126.4	119.7	119.7	119.7	112.3	112.3	112.3	104.2	104.2	104.2		
		SHC	53.1	74.6	96.1	50.8	72.3	93.8	48.2	69.8	91.4	45.4	67.0	88.5		
	76	TC	—	134.6	134.6	—	127.8	127.8	—	120.3	120.3	—	112.3	112.3		
		SHC	—	57.2	78.8	—	55.0	76.6	—	52.6	74.1	—	50.0	71.5		

LEGEND

- Do not operate in this region
- Cfm — Cubic feet per minute (supply air)
- EAT (db) — Entering air temperature (dry bulb)
- EAT (wb) — Entering air temperature (wet bulb)
- SHC — Sensible heat capacity (1000 Btuh) Gross
- TC — Total capacity (1000 Btuh) Gross

Performance data (cont)

548J 12 COOLING CAPACITY

				AMBIENT TEMPERATURE (F)												
				85			95			105			115			
				EA (db)			EA (db)			EA (db)			EA (db)			
				75	80	85	75	80	85	75	80	85	75	80	85	
3000 Cfm	EA (wb)	58	TC	102.8	102.8	121.0	96.3	96.3	115.8	90.1	90.1	109.5	83.5	83.5	102.9	
			SHC	82.1	101.5	121.0	76.8	96.3	115.8	70.6	90.1	109.5	64.0	83.5	102.9	
		62	TC	108.0	108.0	114.3	100.4	100.4	111.1	92.1	92.1	107.1	84.2	84.2	102.0	
			SHC	75.4	94.9	114.3	72.2	91.7	111.1	68.1	87.6	107.1	63.1	82.5	102.0	
		67	TC	120.5	120.5	120.5	113.5	113.5	113.5	104.9	104.9	104.9	95.2	95.2	95.2	
			SHC	60.2	79.7	99.2	57.7	77.2	96.7	54.4	73.9	93.4	50.8	70.3	89.7	
	72	TC	132.8	132.8	132.8	126.5	126.5	126.5	118.6	118.6	118.6	109.3	109.3	109.3		
		SHC	44.5	64.0	83.4	42.2	61.7	81.2	39.5	59.0	78.5	36.4	55.9	75.3		
	76	TC	—	142.0	142.0	—	136.0	136.0	—	129.1	129.1	—	120.3	120.3		
		SHC	—	50.9	70.4	—	48.8	68.2	—	46.6	66.0	—	43.7	63.2		
	3500 Cfm	EA (wb)	58	TC	108.2	108.2	130.9	102.5	102.5	125.2	95.5	95.5	118.2	88.3	88.3	111.0
				SHC	85.5	108.2	130.9	79.8	102.5	125.2	72.8	95.5	118.2	65.6	88.3	111.0
62			TC	111.4	111.4	125.8	104.6	104.6	122.1	96.3	96.3	117.0	88.7	88.7	110.7	
			SHC	80.4	103.1	125.8	76.7	99.4	122.1	71.6	94.3	117.0	65.3	88.0	110.7	
67			TC	123.4	123.4	123.4	116.3	116.3	116.3	107.9	107.9	107.9	97.5	97.5	98.9	
			SHC	62.6	85.3	108.0	60.1	82.9	105.6	57.2	79.9	102.6	53.5	76.2	98.9	
72		TC	135.4	135.4	135.4	129.2	129.2	129.2	121.2	121.2	121.2	112.0	112.0	112.0		
		SHC	44.2	67.0	89.7	42.2	64.9	87.6	39.5	62.2	85.0	36.5	59.3	82.0		
76		TC	—	144.6	144.6	—	138.4	138.4	—	131.3	131.3	—	—	—		
		SHC	—	51.9	74.6	—	50.0	72.7	—	47.8	70.5	—	—	—		
4000 Cfm		EA (wb)	58	TC	112.7	112.7	138.7	106.9	106.9	132.9	99.9	99.9	125.9	92.3	92.3	118.2
				SHC	86.7	112.7	138.7	81.0	106.9	132.9	74.0	99.9	125.9	66.3	92.3	118.2
	62		TC	114.0	114.0	135.3	107.6	107.6	131.3	100.4	100.4	125.5	92.3	92.3	118.3	
			SHC	83.4	109.3	135.3	79.3	105.3	131.3	73.6	99.6	125.5	66.4	92.3	118.3	
	67		TC	125.4	125.4	125.4	118.2	118.2	118.2	109.5	109.5	111.2	99.1	99.1	107.7	
			SHC	64.5	90.5	116.4	62.2	88.1	114.1	59.3	85.3	111.2	55.8	81.8	107.7	
	72	TC	137.2	137.2	137.2	130.7	130.7	130.7	122.8	122.8	122.8	113.5	113.5	113.5		
		SHC	43.6	69.6	95.5	41.7	67.6	93.6	39.2	65.1	91.1	36.3	62.2	88.2		
	76	TC	—	146.3	146.3	—	139.9	139.9	—	132.5	132.5	—	—	—		
		SHC	—	52.8	78.7	—	50.8	76.8	—	48.6	74.6	—	—	—		
	4500 Cfm	EA (wb)	58	TC	115.9	115.9	145.2	110.4	110.4	139.6	103.4	103.4	132.6	95.4	95.4	124.6
				SHC	86.7	115.9	145.2	81.2	110.4	139.6	74.2	103.4	132.6	66.2	95.4	124.6
62			TC	116.6	116.6	143.2	110.4	110.4	139.4	103.9	103.9	131.8	95.4	95.4	124.6	
			SHC	84.8	114.0	143.2	81.0	110.2	139.4	73.4	102.6	131.8	66.2	95.4	124.6	
67			TC	126.5	126.5	126.5	119.5	119.5	122.2	110.6	110.6	119.6	100.2	100.2	116.1	
			SHC	65.9	95.1	124.3	63.8	93.0	122.2	61.2	90.4	119.6	57.7	86.9	116.1	
72		TC	138.0	138.0	138.0	131.5	131.5	131.5	123.9	123.9	123.9	114.2	114.2	114.2		
		SHC	42.7	71.9	101.1	40.8	70.0	99.2	38.5	67.7	96.9	35.6	64.8	94.0		
76		TC	—	147.3	147.3	—	140.6	140.6	—	—	—	—	—	—		
		SHC	—	53.3	82.6	—	51.4	80.6	—	—	—	—	—	—		
5000 Cfm		EA (wb)	58	TC	118.4	118.4	150.9	112.9	112.9	145.4	105.9	105.9	138.4	97.8	97.8	130.2
				SHC	86.0	118.4	150.9	80.5	112.9	145.4	73.5	105.9	138.4	65.3	97.8	130.2
	62		TC	118.5	118.5	150.7	113.5	113.5	144.5	106.0	106.0	138.4	97.9	97.9	130.3	
			SHC	85.8	118.3	150.7	79.6	112.0	144.5	73.5	106.0	138.4	65.4	97.9	130.3	
	67		TC	126.9	126.9	131.8	120.0	120.0	130.0	111.1	111.1	127.4	100.8	100.8	123.9	
			SHC	66.9	99.4	131.8	65.1	97.5	130.0	62.5	94.9	127.4	59.0	91.4	123.9	
	72	TC	138.4	138.4	138.4	131.6	131.6	131.6	124.0	124.0	124.0	114.2	114.2	114.2		
		SHC	41.4	73.8	106.3	39.5	71.9	104.4	37.3	69.8	102.2	34.6	67.0	99.5		
	76	TC	—	147.7	147.7	—	140.9	140.9	—	—	—	—	—	—		
		SHC	—	53.6	86.1	—	51.7	84.2	—	—	—	—	—	—		

LEGEND

- Do not operate in this region
- Cfm — Cubic feet per minute (supply air)
- EAT (db) — Entering air temperature (dry bulb)
- EAT (wb) — Entering air temperature (wet bulb)
- SHC — Sensible heat capacity (1000 Btuh) Gross
- TC — Total capacity (1000 Btuh) Gross

548J 14 COOLING CAPACITY

				AMBIENT TEMPERATURE (F)											
				85			95			105			115		
				EA (db)			EA (db)			EA (db)			EA (db)		
				75	80	85	75	80	85	75	80	85	75	80	85
3750 Cfm	EA (wb)	58	TC	126.4	126.4	143.6	119.1	119.1	135.3	111.8	111.8	127.0	104.0	104.0	118.2
			SHC	109.2	126.4	143.6	102.9	119.1	135.3	96.5	111.8	127.0	89.8	104.0	118.2
		62	TC	134.5	134.5	138.4	124.7	124.7	133.4	114.9	114.9	128.1	105.8	105.8	120.8
			SHC	100.3	119.4	138.4	95.5	114.4	133.4	90.5	109.3	128.1	84.6	102.7	120.8
		67	TC	149.6	149.6	149.6	140.5	140.5	140.5	130.0	130.0	130.0	118.8	118.8	118.8
			SHC	83.5	102.5	121.4	79.8	98.9	118.1	75.4	94.6	113.7	70.8	89.9	109.1
		72	TC	161.4	161.4	161.4	155.2	155.2	155.2	146.4	146.4	146.4	135.7	135.7	135.7
			SHC	64.5	83.5	102.5	62.1	81.2	100.4	58.8	78.1	97.3	54.8	74.1	93.3
76	TC	—	169.5	169.5	—	163.1	163.1	—	156.8	156.8	—	147.7	147.7		
	SHC	—	68.1	88.7	—	65.7	86.2	—	63.4	83.7	—	60.3	80.3		
4375 Cfm	EA (wb)	58	TC	134.6	134.6	152.9	126.8	126.8	144.1	118.8	118.8	135.0	110.5	110.5	125.6
			SHC	116.3	134.6	152.9	109.6	126.8	144.1	102.7	118.8	135.0	95.5	110.5	125.6
		62	TC	139.9	139.9	151.3	130.0	130.0	145.7	120.7	120.7	138.1	111.2	111.2	130.1
			SHC	107.9	129.6	151.3	102.8	124.2	145.7	96.7	117.4	138.1	90.4	110.3	130.1
		67	TC	153.7	153.7	153.7	145.2	145.2	145.2	134.5	134.5	134.5	122.9	122.9	122.9
			SHC	87.9	109.4	131.0	84.8	106.8	128.8	80.6	102.6	124.7	75.8	97.9	120.0
		72	TC	164.6	164.6	164.6	158.2	158.2	158.2	150.5	150.5	150.5	139.9	139.9	139.9
			SHC	66.0	87.2	108.5	63.6	85.1	106.5	60.9	82.8	104.8	57.0	79.1	101.2
76	TC	—	172.4	172.4	—	165.7	165.7	—	159.3	159.3	—	150.8	150.8		
	SHC	—	70.2	93.5	—	67.8	91.0	—	65.7	88.8	—	62.8	85.8		
5000 Cfm	EA (wb)	58	TC	141.4	141.4	160.6	133.5	133.5	151.6	125.0	125.0	142.0	116.2	116.2	132.0
			SHC	122.1	141.4	160.6	115.3	133.5	151.6	108.0	125.0	142.0	100.4	116.2	132.0
		62	TC	144.4	144.4	162.1	135.4	135.4	155.1	125.9	125.9	147.1	116.4	116.4	137.6
			SHC	114.3	138.2	162.1	108.5	131.8	155.1	102.2	124.6	147.1	95.3	116.4	137.6
		67	TC	156.6	156.6	156.6	148.8	148.8	148.8	138.1	138.1	138.1	126.3	126.3	130.2
			SHC	91.7	115.6	139.5	89.3	113.9	138.6	85.3	110.2	135.0	80.6	105.4	130.2
		72	TC	167.0	167.0	167.0	160.5	160.5	160.5	153.3	153.3	153.3	142.9	142.9	142.9
			SHC	67.3	90.6	113.9	64.9	88.6	112.2	62.5	87.0	111.4	58.9	83.7	108.5
76	TC	—	174.6	174.6	—	167.5	167.5	—	160.7	160.7	—	152.9	152.9		
	SHC	—	72.2	98.1	—	69.8	95.6	—	67.4	92.9	—	64.8	90.2		
5625 Cfm	EA (wb)	58	TC	146.6	146.6	166.6	139.0	139.0	157.9	130.3	130.3	148.1	121.2	121.2	137.7
			SHC	126.6	146.6	166.6	120.0	139.0	157.9	112.6	130.3	148.1	104.7	121.2	137.7
		62	TC	148.4	148.4	169.8	139.9	139.9	163.3	130.5	130.5	154.3	121.3	121.3	143.4
			SHC	118.8	144.3	169.8	113.5	138.4	163.3	106.8	130.5	154.3	99.2	121.3	143.4
		67	TC	158.8	158.8	158.8	151.5	151.5	151.5	140.9	140.9	144.6	129.1	129.1	140.0
			SHC	95.1	121.2	147.3	93.3	120.4	147.4	89.6	117.1	144.6	85.0	112.5	140.0
		72	TC	168.9	168.9	168.9	162.1	162.1	162.1	155.3	155.3	155.3	145.1	145.1	145.1
			SHC	68.4	93.7	118.9	66.1	91.7	117.3	63.9	90.6	117.3	60.6	87.9	115.2
76	TC	—	176.2	176.2	—	168.9	168.9	—	161.7	161.7	—	154.3	154.3		
	SHC	—	73.9	101.8	—	71.3	98.8	—	68.8	96.1	—	66.6	94.1		
6250 Cfm	EA (wb)	58	TC	150.6	150.6	171.1	143.5	143.5	163.1	134.9	134.9	153.3	125.5	125.5	142.6
			SHC	130.0	150.6	171.1	123.9	143.5	163.1	116.5	134.9	153.3	108.4	125.5	142.6
		62	TC	151.4	151.4	176.1	143.7	143.7	169.9	135.1	135.1	159.7	125.6	125.6	148.5
			SHC	122.6	149.3	176.1	117.6	143.7	169.9	110.5	135.1	159.7	102.7	125.6	148.5
		67	TC	160.4	160.4	160.4	153.4	153.4	155.3	143.2	143.2	153.4	131.3	131.3	148.7
			SHC	98.2	126.4	154.5	96.8	126.0	155.3	93.6	123.5	153.4	88.9	118.8	148.7
		72	TC	170.3	170.3	170.3	163.4	163.4	163.4	156.7	156.7	156.7	146.8	146.8	146.8
			SHC	69.5	96.5	123.5	67.1	94.5	121.9	65.1	93.8	122.5	62.0	91.7	121.3
76	TC	—	177.5	177.5	—	170.1	170.1	—	162.7	162.7	—	155.4	155.4		
	SHC	—	75.2	104.7	—	72.6	101.8	—	70.2	99.2	—	68.2	97.7		

LEGEND

- Do not operate in this region
- Cfm — Cubic feet per minute (supply air)
- EAT (db) — Entering air temperature (dry bulb)
- EAT (wb) — Entering air temperature (wet bulb)
- SHC — Sensible heat capacity (1000 Btuh) Gross
- TC — Total capacity (1000 Btuh) Gross

Performance data (cont)

548J 07 HEATING CAPACITY

RETURN AIR (°F db)	CFM (Standard Air)		TEMPERATURE AIR ENTERING OUTDOOR COIL (°F db at 70% rh)								
			-10	0	10	17	30	40	47	50	60
55	1800	Capacity	20.9	28.1	35.9	40.7	51.7	61.3	67.6	70.2	79.3
		Int. Cap.	19.3	25.9	33.0	37.1	45.3	61.3	67.6	70.2	79.3
	2400	Capacity	22.4	29.8	37.3	42.8	54.2	63.8	70.1	72.8	82.0
		Int. Cap.	20.7	27.4	34.3	39.0	47.5	63.8	70.1	72.8	82.0
	3000	Capacity	25.2	31.5	39.0	44.6	56.7	65.9	71.9	74.5	83.3
		Int. Cap.	23.3	28.9	35.8	40.7	49.7	65.9	71.9	74.5	83.3
70	1800	Capacity	16.0	23.5	31.1	36.5	47.2	56.3	63.6	66.3	75.2
		Int. Cap.	14.8	21.6	28.5	33.3	41.4	56.3	63.6	66.3	75.2
	2400	Capacity	17.6	25.4	33.2	38.7	50.0	59.8	66.7	69.3	78.3
		Int. Cap.	16.3	23.4	30.5	35.3	43.8	59.8	66.7	69.3	78.3
	3000	Capacity	19.2	27.2	35.1	40.7	52.3	62.6	68.8	71.4	80.3
		Int. Cap.	17.7	25.0	32.3	37.1	45.8	62.6	68.8	71.4	80.3
80	1800	Capacity	12.2	19.8	27.6	33.1	43.7	52.6	59.6	62.9	72.1
		Int. Cap.	11.2	18.2	25.3	30.1	38.3	52.6	59.6	62.9	72.1
	2400	Capacity	13.6	21.7	29.8	35.5	46.7	56.1	63.8	66.6	75.5
		Int. Cap.	12.6	20.0	27.3	32.3	40.9	56.1	63.8	66.6	75.5
	3000	Capacity	15.3	23.5	31.8	37.6	49.1	58.9	66.4	69.0	77.8
		Int. Cap.	14.1	21.7	29.2	34.3	43.0	58.9	66.4	69.0	77.8

LEGEND

- rh — Relative humidity
- db — Dry bulb
- Capacity — Instantaneous capacity (1000 Btuh). Includes indoor fan motor heat at ARHI static conditions.
- Int. Cap. — Integrated capacity. This can be calculated by taking instantaneous capacity and subtracting the effects of frost on the outdoor coil and the heat required to defrost the coil.
-  — Standard rating point

548J 08 HEATING CAPACITY

RETURN AIR (°F db)	CFM (Standard Air)		TEMPERATURE AIR ENTERING OUTDOOR COIL (°F db at 70% rh)								
			-10	0	10	17	30	40	47	50	60
55	2250	Capacity	—	—	46.9	53.5	66.3	77.2	86.2	89.4	103.3
		Int. Cap.	—	—	43.1	48.7	58.1	77.2	86.2	89.4	103.3
	3000	Capacity	—	—	—	—	68.5	80.2	89.8	93.1	106.7
		Int. Cap.	—	—	—	—	60.0	80.2	89.8	93.1	106.7
	3750	Capacity	—	—	—	58.9	72.5	84.6	94.5	97.6	110.6
		Int. Cap.	—	—	—	53.7	63.5	84.6	94.5	97.6	110.6
70	2250	Capacity	25.9	34.6	43.6	50.2	62.7	73.0	81.4	84.5	98.0
		Int. Cap.	23.9	31.8	40.0	45.7	55.0	73.0	81.4	84.5	98.0
	3000	Capacity	27.4	36.2	45.5	52.2	65.1	75.9	85.0	88.2	102.1
		Int. Cap.	25.3	33.4	41.8	47.6	57.0	75.9	85.0	88.2	102.1
	3750	Capacity	31.0	40.0	49.3	56.1	69.1	80.4	89.8	93.2	106.5
		Int. Cap.	28.6	36.8	45.3	51.1	60.6	80.4	89.8	93.2	106.5
80	2250	Capacity	22.5	31.5	40.7	47.3	60.1	70.3	78.2	81.2	94.3
		Int. Cap.	20.8	29.0	37.3	43.1	52.6	70.3	78.2	81.2	94.3
	3000	Capacity	24.1	33.3	42.7	49.5	62.5	73.1	81.6	84.7	98.6
		Int. Cap.	22.3	30.6	39.2	45.2	54.8	73.1	81.6	84.7	98.6
	3750	Capacity	27.8	37.1	46.6	53.5	66.7	77.5	86.4	89.7	103.4
		Int. Cap.	25.7	34.1	42.8	48.8	58.4	77.5	86.4	89.7	103.4

LEGEND

- Operation not permissible
- rh — Relative humidity
- db — Dry bulb
- Capacity** — Instantaneous capacity (1000 Btuh). Includes indoor fan motor heat at ARHI static conditions.
- Int. Cap.** — Integrated capacity. This can be calculated by taking instantaneous capacity and subtracting the effects of frost on the outdoor coil and the heat required to defrost the coil.
- Standard rating point

Performance data (cont)

548J 09 HEATING CAPACITY

RETURN AIR (°F db)	CFM (Standard Air)		TEMPERATURE AIR ENTERING OUTDOOR COIL (°F db at 70% rh)								
			-10	0	10	17	30	40	47	50	60
55	2550	Capacity	33.1	42.7	52.7	60.0	75.6	87.4	97.5	100.6	113.8
		Int. Cap.	30.7	39.3	48.3	54.7	66.2	87.4	97.5	100.6	113.8
	3400	Capacity	34.4	44.0	54.2	61.8	77.5	89.9	100.2	103.1	115.7
		Int. Cap.	31.8	40.5	49.8	56.4	67.9	89.9	100.2	103.1	115.7
	4250	Capacity	38.0	47.7	58.0	65.8	81.5	94.2	103.9	106.6	118.2
		Int. Cap.	35.2	43.9	53.2	60.0	71.4	94.2	103.9	106.6	118.2
70	2550	Capacity	29.0	38.6	48.6	55.9	70.7	83.5	93.1	96.2	109.5
		Int. Cap.	26.8	35.5	44.6	51.0	61.9	83.5	93.1	96.2	109.5
	3400	Capacity	30.3	40.2	50.4	58.0	73.5	86.1	96.5	99.2	111.9
		Int. Cap.	28.0	37.0	46.3	52.9	64.4	86.1	96.5	99.2	111.9
	4250	Capacity	34.0	44.0	54.4	62.1	77.8	90.5	100.5	103.3	115.2
		Int. Cap.	31.5	40.5	50.0	56.6	68.2	90.5	100.5	103.3	115.2
80	2550	Capacity	25.3	35.0	45.2	52.6	67.1	80.0	90.0	93.2	106.5
		Int. Cap.	23.4	32.2	41.5	48.0	58.8	80.0	90.0	93.2	106.5
	3400	Capacity	26.6	36.7	47.2	54.8	69.8	83.0	93.1	96.2	109.2
		Int. Cap.	24.6	33.8	43.3	50.0	61.2	83.0	93.1	96.2	109.2
	4250	Capacity	30.4	40.6	51.2	59.0	74.4	87.7	97.7	100.7	112.8
		Int. Cap.	28.1	37.4	47.0	53.8	65.1	87.7	97.7	100.7	112.8

LEGEND

- rh** — Relative humidity
- db** — Dry bulb
- Capacity** — Instantaneous capacity (1000 Btuh). Includes indoor fan motor heat at ARHI static conditions.
- Int. Cap.** — Integrated capacity. This can be calculated by taking instantaneous capacity and subtracting the effects of frost on the outdoor coil and the heat required to defrost the coil.
-  — Standard rating point

548J 12 HEATING CAPACITY

RETURN AIR (°F db)	CFM (Standard Air)		TEMPERATURE AIR ENTERING OUTDOOR COIL (°F db at 70% rh)								
			-10	0	10	17	30	40	47	50	60
55	3000	Capacity	41.8	52.4	64.1	72.8	90.4	105.3	118.0	121.9	140.3
		Int. Cap.	38.7	48.2	58.8	66.3	79.2	105.3	118.0	121.9	140.3
	4000	Capacity	43.3	54.0	66.0	74.5	92.7	107.8	120.2	124.1	142.1
		Int. Cap.	40.0	49.7	60.6	68.0	81.2	107.8	120.2	124.1	142.1
	5000	Capacity	46.9	57.7	69.7	78.2	96.6	111.5	123.5	127.3	142.3
		Int. Cap.	43.3	53.1	64.0	71.3	84.6	111.5	123.5	127.3	142.3
70	3000	Capacity	37.4	48.2	59.7	68.5	86.2	100.6	113.0	117.1	135.3
		Int. Cap.	34.6	44.4	54.8	62.4	75.5	100.6	113.0	117.1	135.3
	4000	Capacity	39.0	49.9	61.6	70.7	88.5	103.3	115.9	119.8	137.6
		Int. Cap.	36.1	45.9	56.6	64.5	77.5	103.3	115.9	119.8	137.6
	5000	Capacity	42.6	53.7	65.5	74.8	92.5	107.5	119.6	123.4	140.6
		Int. Cap.	39.4	49.4	60.1	68.2	81.1	107.5	119.6	123.4	140.6
80	3000	Capacity	33.9	44.8	56.5	65.1	83.2	97.3	109.5	113.4	131.6
		Int. Cap.	31.4	41.3	51.8	59.3	72.9	97.3	109.5	113.4	131.6
	4000	Capacity	35.5	46.6	58.5	67.3	85.5	100.0	112.5	116.5	134.2
		Int. Cap.	32.8	42.9	53.7	61.4	75.0	100.0	112.5	116.5	134.2
	5000	Capacity	39.1	50.4	62.3	71.3	89.6	104.3	116.6	120.4	137.5
		Int. Cap.	36.2	46.4	57.2	65.0	78.5	104.3	116.6	120.4	137.5

LEGEND

- rh** — Relative humidity
- db** — Dry bulb
- Capacity** — Instantaneous capacity (1000 Btuh). Includes indoor fan motor heat at ARHI static conditions.
- Int. Cap.** — Integrated capacity. This can be calculated by taking instantaneous capacity and subtracting the effects of frost on the outdoor coil and the heat required to defrost the coil.
- Standard rating point

Performance data (cont)

548J 14 HEATING CAPACITY

RETURN AIR (°F db)	CFM (Standard Air)		TEMPERATURE AIR ENTERING OUTDOOR COIL (°F db at 70% rh)								
			-10	0	10	17	30	40	47	50	60
55	3750	Capacity	33.7	47.5	69.8	83.1	109.3	131.7	149.7	155.6	180.1
		Int. Cap.	31.2	43.7	64.0	75.8	95.8	131.7	149.7	155.6	180.1
	5000	Capacity	35.7	49.7	72.4	85.8	112.9	136.1	152.9	158.1	178.7
		Int. Cap.	33.0	45.7	66.5	78.2	99.0	136.1	152.9	158.1	178.7
	3250	Capacity	38.9	53.0	76.2	89.5	117.1	139.4	153.5	158.0	175.6
		Int. Cap.	36.0	48.8	70.0	81.6	102.6	139.4	153.5	158.0	175.6
70	3750	Capacity	24.4	38.2	59.4	73.1	99.8	121.2	138.5	144.5	169.7
		Int. Cap.	22.6	35.2	54.5	66.7	87.4	121.2	138.5	144.5	169.7
	5000	Capacity	26.4	40.4	62.1	76.6	103.2	125.4	143.0	148.6	170.3
		Int. Cap.	24.4	37.2	57.0	69.8	90.4	125.4	143.0	148.6	170.3
	3250	Capacity	29.6	43.8	65.9	80.7	107.3	129.8	145.5	150.4	169.1
		Int. Cap.	27.3	40.3	60.5	73.6	94.0	129.8	145.5	150.4	169.1
80	3750	Capacity	17.5	31.4	52.6	65.6	93.3	114.2	131.1	137.0	162.4
		Int. Cap.	16.2	28.9	48.3	59.8	81.8	114.2	131.1	137.0	162.4
	5000	Capacity	19.3	33.4	55.2	68.7	96.6	118.2	135.7	141.5	164.0
		Int. Cap.	17.8	30.8	50.7	62.6	84.6	118.2	135.7	141.5	164.0
	3250	Capacity	22.4	40.3	58.8	72.7	100.6	122.6	139.3	144.3	163.8
		Int. Cap.	20.7	37.1	54.0	66.3	88.2	122.6	139.3	144.3	163.8

LEGEND

- rh — Relative humidity
- db — Dry bulb
- Capacity — Instantaneous capacity (1000 Btuh). Includes indoor fan motor heat at ARHI static conditions.
- Int. Cap. — Integrated capacity. This can be calculated by taking instantaneous capacity and subtracting the effects of frost on the outdoor coil and the heat required to defrost the coil.
-  — Standard rating point

STATIC PRESSURE ADDERS (FACTORY OPTIONS AND/OR ACCESSORIES)

Economizer

548J 07 ECONOMIZER STATIC PRESSURE DROP

CFM (in. wg)	900	1200	1500	1800	2100	2400	2700	3000
Vertical Economizer	0.02	0.04	0.07	0.09	0.13	0.17	0.21	0.26
Horizontal Economizer	0.03	0.05	0.07	0.10	0.14	0.18	0.22	0.27

548J 08-12 ECONOMIZER STATIC PRESSURE DROP

CFM (in. wg)	2000	2500	3000	3500	4000	4500	5000	5500	6000
Vertical Economizer	0.04	0.07	0.11	0.15	0.20	0.26	0.33	0.40	0.48
Horizontal Economizer	0.07	0.11	0.15	0.21	0.27	0.34	0.42	0.51	0.61

548J 14 ECONOMIZER STATIC PRESSURE DROP

CFM (in. wg)	3250	3750	4250	4750	5250	5750	6250
Vertical Economizer	0.01	0.02	0.03	0.03	0.04	0.05	0.06
Horizontal Economizer	0.08	0.10	0.13	0.17	0.21	0.25	0.29

Electric Heaters

548J 07 ELECTRIC HEATER STATIC PRESSURE DROP

CFM	900	1200	1500	1800	2100	2400	2700	3000
1 Electric Heater Module*	0.05	0.07	0.09	0.10	0.11	0.12	0.13	0.14
2 Electric Heater Modules*	0.15	0.16	0.16	0.17	0.17	0.18	0.19	0.18

*Use 2 heater module pressure drop for CRHEATER360A00-362A00, 371A00-373A00, 378A00, 379A00. Prior to the release of the CRHEATER360A00-362A00, 371A00-373A00, 378A00, 379A00, the necessary kW was achieved with 2 separate heater modules. Now the heat capacity is achieved with a single module.

548J 08-12 ELECTRIC HEATER STATIC PRESSURE DROP

CFM	2000	2500	3000	3500	4000	4500	5000	5500	6000
1 Electric Heater Module*	0.03	0.04	0.05	0.07	0.08	0.10	0.13	0.15	0.18
2 Electric Heater Modules*	0.03	0.05	0.06	0.08	0.10	0.12	0.15	0.17	0.20

*Use 2 heater module pressure drop for the CRHEATER128B00 and 129B00 (41.7 kW and 50 kW). Prior to the release of the CRHEATER128B00 and 129B00, 41.7 kW and 50 kW were achieved with 2 separate heater modules. Now the heat capacity is achieved with a single module. Use 2 heater module pressure drop.

548J 14 ELECTRIC HEATER STATIC PRESSURE DROP

CFM	3250	3750	4250	4750	5250	5750	6250
Vertical - 1 Electric Heater Module*	0.02	0.02	0.02	0.03	0.03	0.03	0.04
Vertical - 2 Electric Heater Modules*	0.03	0.03	0.04	0.05	0.06	0.07	0.08
Horizontal - 1 Electric Heater Module*	0.03	0.04	0.05	0.06	0.07	0.08	0.09
Horizontal - 2 Electric Heater Modules*	0.03	0.04	0.04	0.05	0.06	0.07	0.08

*Use 2 heater module pressure drop for CRHEATER367A00-370A00, 374A00-377A00, 381A00-384A00. Prior to the release of the CRHEATER367A00-370A00, 374A00-377A00, 381A00-384A00, the necessary kW was achieved with 2 separate heater modules. Now the heat capacity is achieved with a single module.

Performance data (cont)

STATIC PRESSURE ADDERS (FACTORY OPTIONS AND/OR ACCESSORIES) (cont)

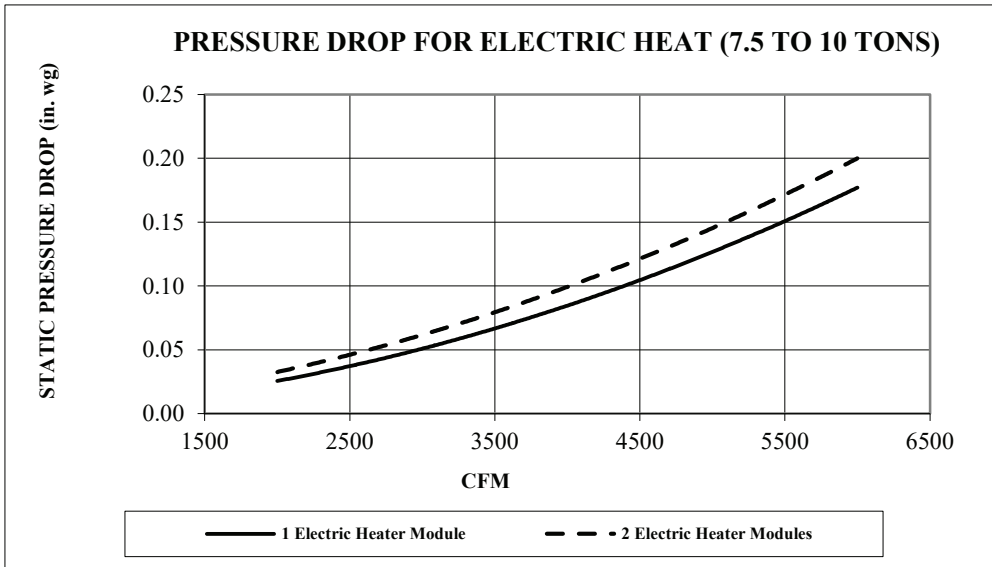
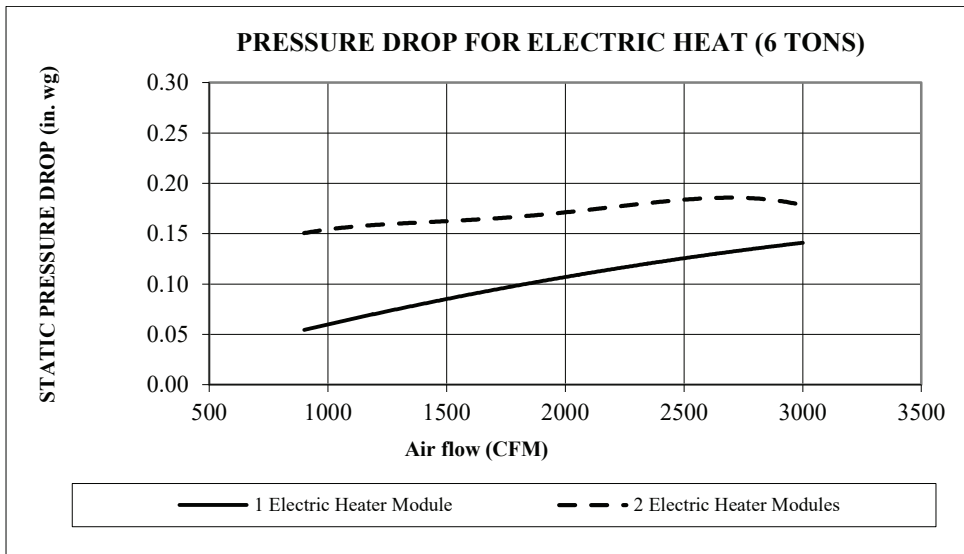

STATIC PRESSURE ADDERS (FACTORY OPTIONS AND/OR ACCESSORIES) (cont)

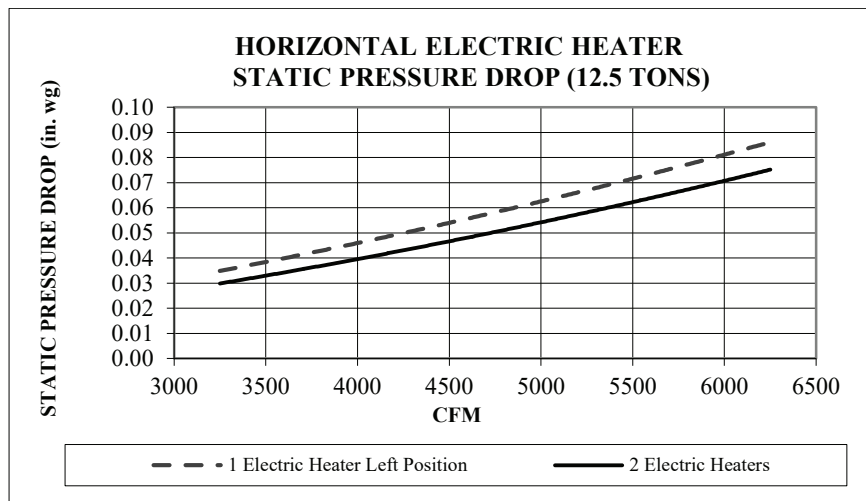
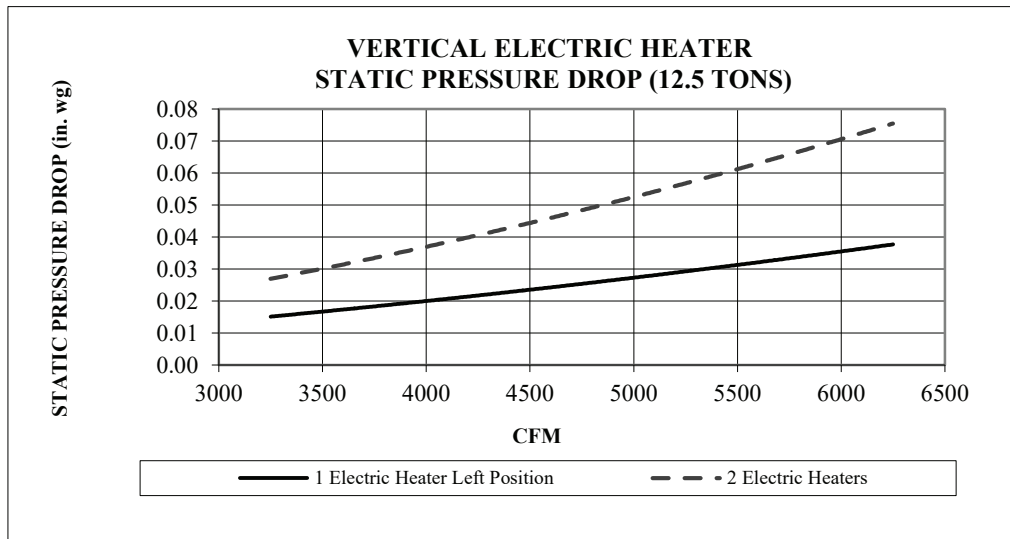

Performance data (cont)

ECONOMIZER, BAROMETRIC RELIEF, AND POWER EXHAUST PERFORMANCE

BAROMETRIC RELIEF FLOW CAPACITY (6 TO 10 TONS)

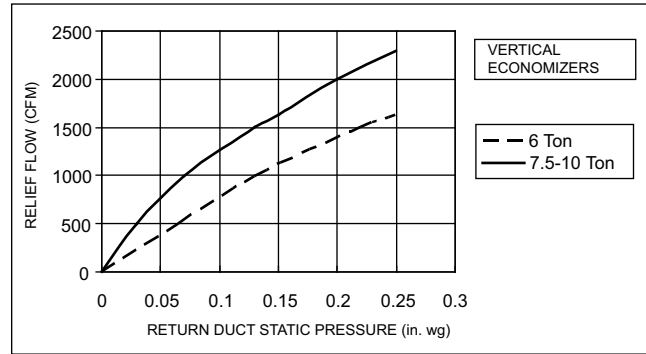
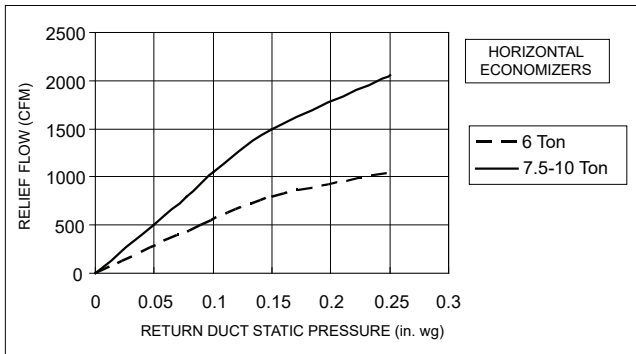

RETURN AIR PRESSURE DROP (6 TO 10 TONS)

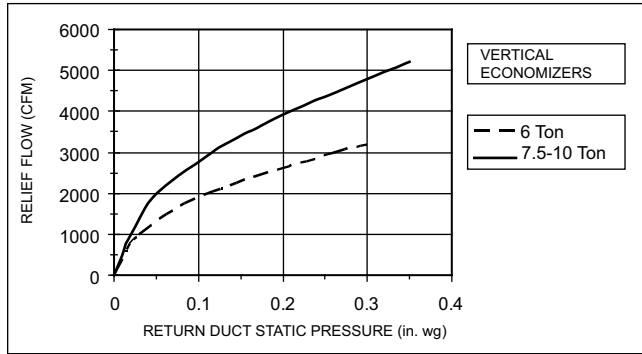
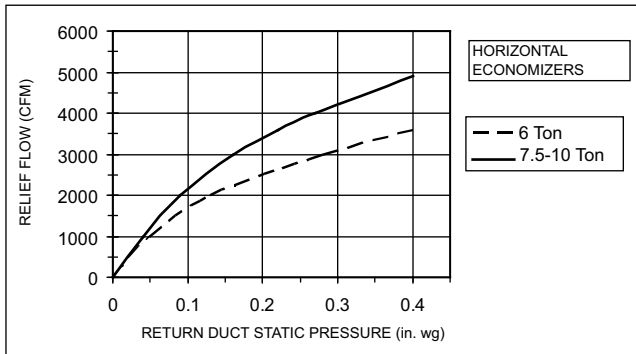

ECONOMIZER, BAROMETRIC RELIEF, AND POWER EXHAUST PERFORMANCE (cont)

BAROMETRIC RELIEF FLOW CAPACITY (12.5 TONS)

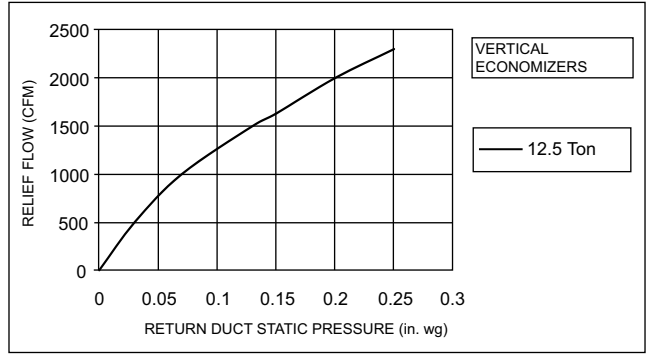
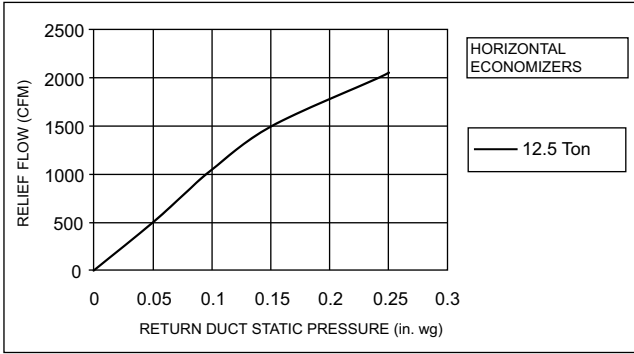

RETURN AIR PRESSURE DROP (12.5 TONS)

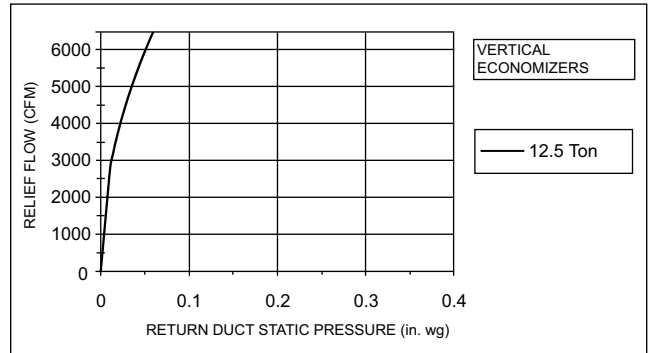
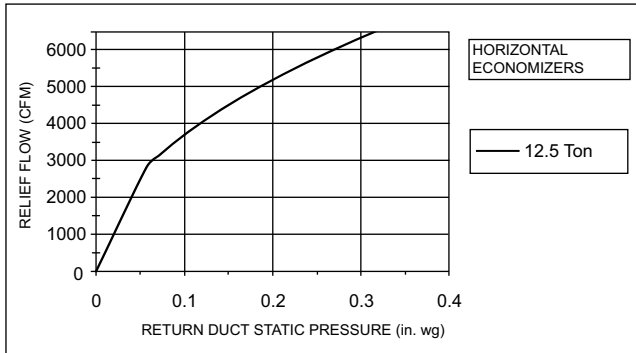

Fan data

GENERAL FAN PERFORMANCE NOTES

1. Interpolation is permissible. Do not extrapolate.
2. External static pressure is the static pressure difference between the return duct and the supply duct plus the static pressure caused by any FIOPs or accessories.
3. Tabular data accounts for pressure loss due to clean filters, unit casing, and wet coils. Factory options and accessories may add static pressure losses, as shown on page 39. Selection software is available, through your salesperson, to help you select the best motor/drive combination for your application.
4. The fan performance tables offer motor/drive recommendations. In cases when two motor/drive combinations would work, Bryant recommends the lower horsepower option.
5. For information on the electrical properties of Bryant motors, see the Electrical Data section on page 52.
6. For more information on the performance limits of Bryant motors, see the Application Data section on page 104.

548J*07A – 6 TON HORIZONTAL SUPPLY

CFM	Available External Static Pressure (in. wg)									
	0.2		0.4		0.6		0.8		1.0	
	RPM	BHP	RPM	BHP	RPM	BHP	RPM	BHP	RPM	BHP
1800	822	0.51	927	0.66	1018	0.82	1100	0.98	1174	1.15
1950	872	0.62	973	0.79	1061	0.95	1140	1.13	1213	1.31
2100	923	0.75	1019	0.92	1104	1.10	1182	1.29	1253	1.48
2250	974	0.90	1067	1.08	1149	1.27	1224	1.46	1294	1.66
2400	1026	1.06	1115	1.26	1195	1.46	1268	1.66	1336	1.87
2550	1079	1.25	1164	1.46	1241	1.67	1312	1.88	1379	2.10
2700	1132	1.46	1214	1.67	1289	1.90	1358	2.12	1422	2.35
2850	1186	1.69	1264	1.92	1336	2.15	1404	2.39	1467	2.63
3000	1240	1.94	1315	2.18	1385	2.43	1451	2.68	1512	2.93

CFM	Available External Static Pressure (in. wg)									
	1.2		1.4		1.6		1.8		2.0	
	RPM	BHP	RPM	BHP	RPM	BHP	RPM	BHP	RPM	BHP
1800	1244	1.33	1308	1.51	1369	1.70	1427	1.90	1483	2.10
1950	1281	1.49	1345	1.68	1405	1.88	1462	2.09	1517	2.30
2100	1320	1.67	1382	1.87	1441	2.08	1498	2.29	—	—
2250	1359	1.87	1420	2.08	1479	2.29	1534	2.51	—	—
2400	1400	2.09	1460	2.31	1517	2.53	—	—	—	—
2550	1441	2.33	1500	2.55	—	—	—	—	—	—
2700	1483	2.59	1541	2.83	—	—	—	—	—	—
2850	1527	2.87	—	—	—	—	—	—	—	—
3000	—	—	—	—	—	—	—	—	—	—

Standard Static: 878-1192 rpm, 1.5 Max BHP (motor is 1.7 HP)
 Medium Static: 1066-1380 rpm, 2.9 Max BHP (motor is 2.9 HP)
 High Static: 1208-1550 rpm, 2.9 Max BHP (motor is 2.9 HP)

548J*07A – 6 TON VERTICAL SUPPLY

CFM	Available External Static Pressure (in. wg)									
	0.2		0.4		0.6		0.8		1.0	
	RPM	BHP	RPM	BHP	RPM	BHP	RPM	BHP	RPM	BHP
1800	907	0.63	1006	0.80	1092	0.97	1169	1.14	1239	1.32
1950	965	0.77	1060	0.95	1143	1.13	1218	1.32	1287	1.51
2100	1024	0.93	1115	1.12	1195	1.32	1268	1.52	1335	1.72
2250	1083	1.11	1170	1.32	1248	1.53	1319	1.74	1385	1.96
2400	1143	1.32	1227	1.54	1302	1.76	1371	1.99	1435	2.22
2550	1203	1.55	1284	1.78	1357	2.02	1424	2.26	1487	2.50
2700	1264	1.81	1342	2.06	1412	2.31	1478	2.56	1539	2.82
2850	1326	2.09	1400	2.36	1469	2.62	1532	2.89	—	—
3000	1387	2.41	1459	2.69	—	—	—	—	—	—

CFM	Available External Static Pressure (in. wg)									
	1.2		1.4		1.6		1.8		2.0	
	RPM	BHP	RPM	BHP	RPM	BHP	RPM	BHP	RPM	BHP
1800	1304	1.51	1365	1.69	1422	1.88	1477	2.08	1528	2.28
1950	1350	1.71	1410	1.91	1467	2.11	1520	2.31	—	—
2100	1398	1.93	1457	2.14	1512	2.35	—	—	—	—
2250	1446	2.18	1504	2.40	—	—	—	—	—	—
2400	1496	2.45	—	—	—	—	—	—	—	—
2550	1546	2.75	—	—	—	—	—	—	—	—
2700	—	—	—	—	—	—	—	—	—	—
2850	—	—	—	—	—	—	—	—	—	—
3000	—	—	—	—	—	—	—	—	—	—

Standard Static: 878-1192 rpm, 1.5 Max BHP (motor is 1.7 HP)
 Medium Static: 1066-1380 rpm, 2.9 Max BHP (motor is 2.9 HP)
 High Static: 1208-1550 rpm, 2.9 Max BHP (motor is 2.9 HP)

Fan data (cont)

548J*08D – 7.5 TON HORIZONTAL SUPPLY

CFM	Available External Static Pressure (in. wg)									
	0.2		0.4		0.6		0.8		1.0	
	RPM	BHP	RPM	BHP	RPM	BHP	RPM	BHP	RPM	BHP
2250	423	0.28	509	0.40	587	0.52	659	0.66	725	0.80
2438	444	0.34	525	0.46	600	0.59	669	0.73	733	0.88
2625	465	0.40	543	0.53	614	0.67	680	0.82	743	0.97
2813	487	0.47	561	0.61	629	0.76	693	0.91	753	1.08
3000	510	0.55	580	0.70	646	0.86	707	1.02	765	1.19
3188	534	0.65	600	0.80	663	0.96	722	1.13	779	1.31
3375	557	0.75	621	0.91	681	1.08	738	1.26	793	1.44
3563	582	0.86	642	1.03	700	1.21	755	1.39	808	1.58
3750	606	0.99	664	1.17	720	1.35	773	1.54	824	1.74

CFM	Available External Static Pressure (in. wg)									
	1.2		1.4		1.6		1.8		2.0	
	RPM	BHP	RPM	BHP	RPM	BHP	RPM	BHP	RPM	BHP
2250	788	0.94	847	1.09	903	1.25	957	1.41	1009	1.58
2438	794	1.03	852	1.19	907	1.36	959	1.52	1010	1.70
2625	802	1.13	858	1.30	911	1.47	963	1.64	1012	1.82
2813	811	1.24	865	1.41	917	1.59	967	1.77	1016	1.96
3000	821	1.36	874	1.54	925	1.72	974	1.91	1021	2.11
3188	832	1.49	884	1.68	933	1.87	981	2.06	1028	2.26
3375	845	1.63	895	1.82	943	2.02	990	2.22	1035	2.43
3563	858	1.78	907	1.98	954	2.19	1000	2.40	1044	2.61
3750	873	1.94	920	2.15	966	2.36	1011	2.58	1054	2.80

Standard Static: 460-652 rpm, 1.2 Max BHP (motor is 1.7 HP)
 Medium Static: 591-838 rpm, 2.9 Max BHP (motor is 2.9 HP)
 High Static: 838-1084 rpm, 2.9 Max BHP (motor is 2.9 HP)

548J*08D – 7.5 TON VERTICAL SUPPLY

CFM	Available External Static Pressure (in. wg)									
	0.2		0.4		0.6		0.8		1.0	
	RPM	BHP	RPM	BHP	RPM	BHP	RPM	BHP	RPM	BHP
2250	447	0.31	528	0.43	597	0.54	658	0.66	713	0.78
2438	470	0.37	548	0.50	615	0.62	675	0.75	729	0.88
2625	494	0.45	569	0.58	634	0.71	692	0.85	745	0.99
2813	518	0.53	590	0.67	653	0.82	710	0.96	763	1.11
3000	543	0.62	612	0.77	673	0.93	729	1.08	780	1.24
3188	568	0.72	635	0.89	694	1.05	749	1.21	799	1.38
3375	593	0.84	658	1.01	716	1.19	769	1.36	818	1.53
3563	619	0.97	681	1.15	737	1.33	789	1.52	837	1.70
3750	645	1.11	705	1.30	760	1.49	810	1.68	857	1.88

CFM	Available External Static Pressure (in. wg)									
	1.2		1.4		1.6		1.8		2.0	
	RPM	BHP	RPM	BHP	RPM	BHP	RPM	BHP	RPM	BHP
2250	764	0.89	812	1.02	856	1.14	899	1.26	939	1.39
2438	779	1.00	826	1.13	870	1.26	912	1.40	952	1.53
2625	795	1.12	841	1.26	885	1.40	926	1.54	966	1.68
2813	811	1.25	857	1.40	900	1.55	941	1.69	980	1.84
3000	828	1.39	873	1.55	916	1.70	956	1.86	995	2.02
3188	846	1.54	890	1.71	932	1.87	972	2.04	1010	2.21
3375	864	1.70	907	1.88	949	2.05	988	2.23	1026	2.40
3563	882	1.88	925	2.06	966	2.25	1005	2.43	1042	2.62
3750	902	2.07	944	2.26	984	2.45	1022	2.65	1059	2.84

Standard Static: 460-652 rpm, 1.2 Max BHP (motor is 1.7 HP)
 Medium Static: 591-838 rpm, 2.9 Max BHP (motor is 2.9 HP)
 High Static: 838-1084 rpm, 2.9 Max BHP (motor is 2.9 HP)

548J*09D – 8.5 TON HORIZONTAL SUPPLY

CFM	Available External Static Pressure (in. wg)									
	0.2		0.4		0.6		0.8		1.0	
	RPM	BHP	RPM	BHP	RPM	BHP	RPM	BHP	RPM	BHP
2550	468	0.39	546	0.52	618	0.66	684	0.80	747	0.96
2763	493	0.47	567	0.61	635	0.76	699	0.91	760	1.07
2975	520	0.57	589	0.72	654	0.87	716	1.03	774	1.20
3188	547	0.68	613	0.83	675	1.00	733	1.17	789	1.34
3400	575	0.80	637	0.96	696	1.14	752	1.31	806	1.50
3613	603	0.94	662	1.11	719	1.29	773	1.48	824	1.67
3825	631	1.09	688	1.27	742	1.46	794	1.66	843	1.86
4038	660	1.26	714	1.45	766	1.65	816	1.85	864	2.06
4250	689	1.45	741	1.65	790	1.86	838	2.07	885	2.29

CFM	Available External Static Pressure (in. wg)									
	1.2		1.4		1.6		1.8		2.0	
	RPM	BHP	RPM	BHP	RPM	BHP	RPM	BHP	RPM	BHP
2550	806	1.11	863	1.28	916	1.45	968	1.62	1018	1.80
2763	817	1.24	871	1.41	924	1.59	974	1.77	1022	1.95
2975	829	1.37	882	1.55	932	1.74	981	1.93	1028	2.12
3188	843	1.53	894	1.71	943	1.90	990	2.10	1036	2.30
3400	858	1.69	907	1.88	955	2.09	1001	2.29	1046	2.50
3613	874	1.87	922	2.07	968	2.28	1013	2.49	1057	2.71
3825	891	2.07	938	2.28	983	2.49	1027	2.71	—	—
4038	910	2.28	955	2.50	999	2.72	1041	2.95	—	—
4250	930	2.51	973	2.74	1015	2.97	1057	3.21	—	—

Standard Static: 460-652 rpm, 1.2 Max BHP (motor is 1.7 HP)
 Medium Static: 591-838 rpm, 2.9 Max BHP (motor is 2.9 HP)
 High Static: 838-1084 rpm, 2.9 Max BHP (motor is 2.9 HP)

548J*09D – 8.5 TON VERTICAL SUPPLY

CFM	Available External Static Pressure (in. wg)									
	0.2		0.4		0.6		0.8		1.0	
	RPM	BHP	RPM	BHP	RPM	BHP	RPM	BHP	RPM	BHP
2550	495	0.43	570	0.56	634	0.70	693	0.83	746	0.96
2763	524	0.53	595	0.67	657	0.81	714	0.95	766	1.09
2975	552	0.63	620	0.79	681	0.94	736	1.09	787	1.24
3188	582	0.76	647	0.92	705	1.08	759	1.25	808	1.41
3400	611	0.89	674	1.07	730	1.24	782	1.42	831	1.59
3613	641	1.05	701	1.23	756	1.42	806	1.60	854	1.79
3825	672	1.22	729	1.42	782	1.61	831	1.81	877	2.00
4038	702	1.41	758	1.62	809	1.83	857	2.03	901	2.24
4250	733	1.62	787	1.84	836	2.06	883	2.28	926	2.49

CFM	Available External Static Pressure (in. wg)									
	1.2		1.4		1.6		1.8		2.0	
	RPM	BHP	RPM	BHP	RPM	BHP	RPM	BHP	RPM	BHP
2550	795	1.09	841	1.23	885	1.36	926	1.50	965	1.64
2763	814	1.24	859	1.38	902	1.53	943	1.68	982	1.82
2975	834	1.40	878	1.55	921	1.71	961	1.86	999	2.02
3188	855	1.57	898	1.74	940	1.90	979	2.07	1017	2.24
3400	876	1.76	919	1.94	960	2.12	998	2.29	1036	2.47
3613	898	1.97	940	2.16	980	2.34	1018	2.53	1055	2.72
3825	921	2.20	962	2.40	1001	2.59	1039	2.79	—	—
4038	944	2.45	984	2.65	1023	2.86	—	—	—	—
4250	968	2.71	—	—	—	—	—	—	—	—

Standard Static: 460-652 rpm, 1.2 Max BHP (motor is 1.7 HP)
 Medium Static: 591-838 rpm, 2.9 Max BHP (motor is 2.9 HP)
 High Static: 838-1084 rpm, 2.9 Max BHP (motor is 2.9 HP)

Fan data (cont)

548J*12D – 10 TON HORIZONTAL SUPPLY

CFM	Available External Static Pressure (in. wg)									
	0.2		0.4		0.6		0.8		1.0	
	RPM	BHP	RPM	BHP	RPM	BHP	RPM	BHP	RPM	BHP
3000	523	0.58	592	0.73	657	0.88	718	1.05	775	1.22
3250	555	0.71	620	0.87	681	1.04	739	1.21	794	1.39
3500	588	0.86	649	1.03	707	1.21	762	1.39	815	1.58
3750	621	1.03	679	1.21	734	1.40	786	1.59	837	1.79
4000	655	1.23	709	1.42	761	1.61	812	1.82	860	2.03
4250	689	1.45	741	1.65	790	1.86	838	2.07	885	2.29
4500	723	1.69	773	1.90	820	2.12	866	2.35	910	2.57
4750	758	1.96	805	2.19	850	2.42	894	2.65	937	2.89
5000	793	2.26	838	2.50	881	2.74	923	2.98	965	3.23

CFM	Available External Static Pressure (in. wg)									
	1.2		1.4		1.6		1.8		2.0	
	RPM	BHP	RPM	BHP	RPM	BHP	RPM	BHP	RPM	BHP
3000	830	1.39	883	1.57	934	1.76	982	1.95	1029	2.14
3250	847	1.57	897	1.76	946	1.96	993	2.16	1039	2.36
3500	865	1.77	914	1.97	961	2.18	1007	2.38	1051	2.60
3750	885	1.99	932	2.20	978	2.42	1022	2.64	1065	2.86
4000	907	2.24	952	2.46	996	2.68	1038	2.91	1080	3.14
4250	930	2.51	973	2.74	1015	2.97	1057	3.21	1097	3.45
4500	954	2.81	996	3.05	1037	3.29	1076	3.54	1115	3.79
4750	979	3.13	1019	3.38	1059	3.63	1097	3.89	—	—
5000	1005	3.49	1044	3.74	1082	4.01	—	—	—	—

Standard Static: 591-839 rpm, 1.7 Max BHP (motor is 2.4 HP)
 Medium Static: 733-949 rpm, 2.8 Max BHP (motor is 3.7 HP)

High Static: 838-1084 rpm, 4.0 Max BHP (motor is 4.9 HP)
Bold indicates field-supplied drive.

548J*12D – 10 TON VERTICAL SUPPLY

CFM	Available External Static Pressure (in. wg)									
	0.2		0.4		0.6		0.8		1.0	
	RPM	BHP	RPM	BHP	RPM	BHP	RPM	BHP	RPM	BHP
3000	556	0.65	623	0.80	684	0.95	738	1.11	789	1.26
3250	590	0.79	655	0.96	713	1.13	766	1.29	815	1.46
3500	625	0.96	687	1.14	742	1.32	794	1.50	841	1.68
3750	661	1.16	719	1.35	773	1.54	822	1.73	869	1.93
4000	697	1.37	753	1.58	804	1.79	852	1.99	897	2.20
4250	733	1.62	787	1.84	836	2.06	883	2.28	926	2.49
4500	770	1.89	821	2.13	869	2.36	914	2.59	956	2.82
4750	807	2.20	856	2.45	902	2.69	945	2.94	986	3.18
5000	844	2.54	891	2.80	936	3.06	978	3.31	1018	3.57

CFM	Available External Static Pressure (in. wg)									
	1.2		1.4		1.6		1.8		2.0	
	RPM	BHP	RPM	BHP	RPM	BHP	RPM	BHP	RPM	BHP
3000	836	1.42	881	1.57	923	1.73	963	1.89	1001	2.05
3250	861	1.63	904	1.79	945	1.96	985	2.13	1023	2.30
3500	886	1.86	929	2.04	969	2.22	1008	2.40	1045	2.58
3750	912	2.12	954	2.31	994	2.50	1031	2.70	1068	2.89
4000	940	2.40	980	2.61	1019	2.81	1056	3.02	1092	3.22
4250	968	2.71	1007	2.93	1045	3.15	1081	3.36	1117	3.58
4500	996	3.05	1035	3.28	1072	3.51	1108	3.74	1142	3.97
4750	1026	3.42	1063	3.66	1100	3.91	—	—	—	—
5000	1056	3.82	—	—	—	—	—	—	—	—

Standard Static: 591-839 rpm, 1.7 Max BHP (motor is 2.4 HP)
 Medium Static: 733-949 rpm, 2.8 Max BHP (motor is 3.7 HP)
 High Static: 838-1084 rpm, 4.0 Max BHP (motor is 4.9 HP)

Bold indicates field-supplied drive.

548J*14D – 12.5 TON HORIZONTAL SUPPLY

CFM	Available External Static Pressure (in. wg)									
	0.2		0.4		0.6		0.8		1.0	
	RPM	BHP	RPM	BHP	RPM	BHP	RPM	BHP	RPM	BHP
3750	381	0.53	452	0.74	520	0.98	584	1.26	645	1.56
4063	401	0.63	468	0.86	531	1.11	592	1.39	651	1.69
4375	421	0.75	484	0.99	544	1.25	601	1.53	657	1.85
4688	441	0.89	501	1.14	558	1.40	612	1.70	666	2.02
5000	462	1.04	519	1.30	573	1.58	625	1.88	675	2.21
5313	483	1.21	537	1.49	589	1.77	638	2.08	686	2.42
5625	504	1.40	556	1.69	605	1.99	653	2.31	699	2.65
5938	525	1.61	575	1.91	622	2.22	668	2.55	712	2.90
6250	546	1.84	595	2.15	640	2.48	684	2.82	<i>726</i>	<i>3.17</i>

CFM	Available External Static Pressure (in. wg)											
	1.2		1.4		1.6		1.8		1.9		2.0	
	RPM	BHP	RPM	BHP	RPM	BHP	RPM	BHP	RPM	BHP	RPM	BHP
3750	703	1.88	757	2.23	808	2.59	855	2.97	878	3.17	900	3.36
4063	707	2.03	760	2.38	810	2.75	857	3.14	880	3.34	902	3.55
4375	711	2.18	763	2.55	812	2.93	859	3.33	882	3.53	904	3.74
4688	717	2.36	767	2.73	815	3.12	862	3.52	884	3.73	906	3.94
5000	725	2.55	773	2.93	820	3.32	865	3.73	887	3.95	908	4.16
5313	734	2.77	780	3.15	825	3.55	869	3.96	890	4.18	912	4.40
5625	744	3.01	788	3.39	832	3.79	874	4.22	895	4.44	916	4.66
5938	755	3.27	798	3.65	840	4.06	881	4.49	901	4.71	921	4.94
6250	768	3.55	808	3.94	849	4.36	888	4.79	908	5.01	927	5.24

Standard Static: 507-676 rpm, 2.9 Max BHP
 Medium Static: 634-833 rpm, 2.9 Max BHP
 High Static: 792-971 rpm
 208v: 6.5 Max BHP
 230v: 6.9 Max BHP
 460v: 7.0 Max BHP
 575v: 8.3 Max BHP

Bold requires standard static drive package with KR11HY153 (1VP34) motor pulley (338 - 507 rpm).
Italics requires high static drive package with KR11HY186 (1VM50) motor pulley (684-864 rpm).

Fan data (cont)

548J*14D – 12.5 TON VERTICAL SUPPLY

CFM	Available External Static Pressure (in. wg)									
	0.2		0.4		0.6		0.8		1.0	
	RPM	BHP	RPM	BHP	RPM	BHP	RPM	BHP	RPM	BHP
3750	441	0.65	513	0.88	582	1.15	647	1.45	707	1.78
4063	466	0.78	533	1.03	598	1.30	660	1.61	718	1.95
4375	491	0.94	554	1.19	615	1.48	674	1.80	730	2.14
4688	517	1.11	576	1.38	634	1.68	690	2.00	744	2.36
5000	543	1.31	599	1.59	653	1.90	706	2.23	758	2.59
5313	570	1.54	622	1.82	674	2.14	724	2.48	774	2.85
5625	596	1.78	646	2.08	695	2.41	743	2.76	<i>790</i>	<i>3.14</i>
5938	623	2.06	671	2.37	717	2.71	<u>763</u>	<u>3.07</u>	808	3.45
6250	650	2.36	695	2.69	<i>740</i>	<i>3.03</i>	<i>784</i>	<i>3.40</i>	827	3.80

CFM	Available External Static Pressure (in. wg)											
	1.2		1.4		1.6		1.8		1.9		2.0	
	RPM	BHP	RPM	BHP	RPM	BHP	RPM	BHP	RPM	BHP	RPM	BHP
3750	764	2.12	816	2.48	866	2.86	912	3.24	935	3.44	956	3.64
4063	773	2.31	825	2.68	874	3.07	921	3.47	943	3.68	965	3.88
4375	784	2.51	835	2.90	883	3.30	929	3.72	951	3.93	<u>973</u>	<u>4.14</u>
4688	795	2.73	845	3.13	893	3.54	938	3.98	960	4.19	<u>981</u>	<u>4.42</u>
5000	808	2.98	856	3.38	903	3.81	947	4.25	969	4.48	<u>990</u>	<u>4.71</u>
5313	822	3.25	868	3.66	914	4.10	957	4.55	<u>978</u>	<u>4.78</u>	<u>999</u>	<u>5.02</u>
5625	837	3.54	882	3.96	925	4.41	968	4.87	<u>989</u>	<u>5.11</u>	<u>1009</u>	<u>5.35</u>
5938	852	3.86	896	4.30	938	4.75	<u>980</u>	<u>5.22</u>	<u>1000</u>	<u>5.46</u>	<u>1020</u>	<u>5.71</u>
6250	869	4.22	911	4.65	952	5.12	<u>992</u>	<u>5.59</u>	<u>1012</u>	<u>5.84</u>	<u>1032</u>	<u>6.09</u>

Standard Static: 507-676 rpm, 2.9 Max BHP
 Medium Static: 634-833 rpm, 2.9 Max BHP
 High Static: 792-971 rpm
 208v: 6.5 Max BHP
 230v: 6.9 Max BHP
 460v: 7.0 Max BHP
 575v: 8.3 Max BHP

Bold requires standard static drive package with KR11HY215 (1VL40) motor pulley (440 - 609 rpm).

Italics requires high static drive package with KR11HY186 (1VM50) motor pulley (684-864 rpm).

Underline requires high static drive package with KR11HY194 (1VP60) motor pulley (864-1061 rpm).

208v: 5.0 Max BHP
 230v: 6.1 Max BHP
 460v: 6.1 Max BHP
 575v: 5.9 Max BHP

PULLEY ADJUSTMENT — BELT DRIVE

548J UNIT		MOTOR/DRIVE COMBO	MOTOR PULLEY TURNS OPEN												
			0	0.5	1	1.5	2	2.5	3	3.5	4	4.5	5	5.5	6
07	3 phase	Standard Static	1192	1161	1129	1098	1066	1035	1004	972	941	909	878	—	—
		Medium Static	1380	1349	1317	1286	1254	1223	1192	1160	1129	1097	1066	—	—
		High Static	1550	1516	1482	1447	1413	1379	1345	1311	1276	1242	1208	—	—
08	3 phase	Standard Static	652	633	614	594	575	556	537	518	498	479	460	—	—
		Medium Static	838	813	789	764	739	715	690	665	640	616	591	—	—
		High Static	1084	1059	1035	1010	986	961	936	912	887	863	838	—	—
09	3 phase	Standard Static	652	633	614	594	575	556	537	518	498	479	460	—	—
		Medium Static	838	813	789	764	739	715	690	665	640	616	591	—	—
		High Static	1084	1059	1035	1010	986	961	936	912	887	863	838	—	—
12	3 phase	Standard Static	652	633	614	594	575	556	537	518	498	479	460	—	—
		Medium Static	838	813	789	764	739	715	690	665	640	616	591	—	—
		High Static	1084	1059	1035	1010	986	961	936	912	887	863	838	—	—
14	3 phase	Standard Static	676	659	642	625	608	592	575	558	541	524	507	*	*
		Medium Static	†	†	833	813	793	773	753	734	714	694	674	654	634
		High Static	†	†	971	953	935	917	899	882	864	846	828	810	792

■ Factory setting

* Do not set motor pulley above 5 turns open for A or AX section belts.

† Do not set motor pulley below 1 turn open for B or BX section belts

NOTE: Do not adjust pulley further than 5 turns open.

Electrical data

548J*07 ELECTRIC HEAT — SINGLE SPEED INDOOR FAN MOTOR

UNIT	NOM. V-Ph-Hz	IFM TYPE	ELECTRIC HEATER PART NUMBER	NOM. PWR (kW)	APP PWR (kW)	APP OUTPUT (MBH)	SINGLE POINT OR JUNCTION KIT PART NUMBER			
							NO C.O. or Unpowered C.O.		w/PWRD C.O.	
							NO P.E.	w/ P.E. (pwrd fr unit)	NO P.E.	w/ P.E. (pwrd fr unit)
548J*07A (1-stage cooling)	208/230-3-60	STD	CRHEATER102A00	6.5	4.9/6.0	16.7/20.4	037	037	037	037
			CRHEATER104B00	10.5	7.9/9.6	26.9/32.9	038	038	038	038
			CRHEATER105A00	16.0	12.0/14.7	41.0/50.1	038	038	038	038
			CRHEATER361A00	21.0	15.8/19.3	53.8/65.8	039	039	039	039
			CRHEATER362A00	26.5	19.9/24.3	67.9/83.0	039	039	039	039
		MED	CRHEATER102A00	6.5	4.9/6.0	16.7/20.4	037	037	037	038
			CRHEATER104B00	10.5	7.9/9.6	26.9/32.9	038	038	038	038
			CRHEATER105A00	16.0	12.0/14.7	41.0/50.1	038	038	038	038
			CRHEATER361A00	21.0	15.8/19.3	53.8/65.8	039	039	039	039
			CRHEATER362A00	26.5	19.9/24.3	67.9/83.0	039	039	039	039
		HIGH	CRHEATER102A00	6.5	4.9/6.0	16.7/20.4	037	037	037	038
			CRHEATER104B00	10.5	7.9/9.6	26.9/32.9	038	038	038	038
			CRHEATER105A00	16.0	12.0/14.7	41.0/50.1	038	038	038	038
			CRHEATER361A00	21.0	15.8/19.3	53.8/65.8	039	039	039	039
			CRHEATER362A00	26.5	19.9/24.3	67.9/83.0	039	039	039	039
	460-3-60	STD	CRHEATER106A00	6.0	5.5	18.8	—	—	—	—
			CRHEATER108A00	11.5	10.6	36.0	—	—	—	—
			CRHEATER109A00	14.0	12.9	43.9	—	—	—	—
			CRHEATER372A00	23.0	21.1	72.1	037	037	037	037
			CRHEATER373A00	25.5	23.4	79.9	037	037	037	037
		MED	CRHEATER106A00	6.0	5.5	18.8	—	—	—	—
			CRHEATER108A00	11.5	10.6	36.0	—	—	—	—
			CRHEATER109A00	14.0	12.9	43.9	—	—	—	—
			CRHEATER372A00	23.0	21.1	72.1	037	037	037	037
CRHEATER373A00			25.5	23.4	79.9	037	037	037	037	
HIGH		CRHEATER106A00	6.0	5.5	18.8	—	—	—	—	
		CRHEATER108A00	11.5	10.6	36.0	—	—	—	—	
		CRHEATER109A00	14.0	12.9	43.9	—	—	—	—	
		CRHEATER372A00	23.0	21.1	72.1	037	037	037	037	
		CRHEATER373A00	25.5	23.4	79.9	037	037	037	037	

LEGEND

—	No Single Point Kit required
APP PWR	208/230v/460v/575v
C.O.	Convenience Outlet
IFM	Indoor Fan Motor
NOM PWR	240v/480v/600v
P.E.	Power Exhaust
Pwrd fr/unit	Powered From Unit
PWRD C.O.	Powered Convenience Outlet

548J*08 ELECTRIC HEAT — SINGLE SPEED INDOOR FAN MOTOR

UNIT	NOM. V-Ph-Hz	IFM TYPE	ELECTRIC HEATER PART NUMBER	NOM. PWR (kW)	APP PWR (kW)	APP OUTPUT (MBH)	SINGLE POINT OR JUNCTION KIT PART NUMBER			
							NO C.O. or Unpowered C.O.		w/PWRD C.O.	
							NO P.E.	w/ P.E. (pwrdr fr unit)	NO P.E.	w/ P.E. (pwrdr fr unit)
548J*08D (2-stage cooling)	208/230-3-60	STD	CRHEATER117A00	10.4	7.8/9.6	26.6/32.6	049	049	049	049
			CRHEATER110A00	16.0	12.0/14.7	41.0/50.1	049	049	049	049
			CRHEATER111A00	24.8	18.6/22.8	63.5/77.7	051	051	051	051
			CRHEATER112A00	32.0	24.0/29.4	82.0/100.3	051	051	051	051
			CRHEATER363A00	42.4	31.8/38.9	108.6/132.9	053	053	053	053
		MED	CRHEATER117A00	10.4	7.8/9.6	26.6/32.6	049	049	049	049
			CRHEATER110A00	16.0	12.0/14.7	41.0/50.1	049	049	049	049
			CRHEATER111A00	24.8	18.6/22.8	63.5/77.7	051	051	051	051
			CRHEATER112A00	32.0	24.0/29.4	82.0/100.3	051	051	051	051
			CRHEATER363A00	42.4	31.8/38.9	108.6/132.9	053	053	053	053
		HIGH	CRHEATER117A00	10.4	7.8/9.6	26.6/32.6	049	049	049	049
			CRHEATER110A00	16.0	12.0/14.7	41.0/50.1	049	049	049	049
			CRHEATER111A00	24.8	18.6/22.8	63.5/77.7	051	051	051	051
			CRHEATER112A00	32.0	24.0/29.4	82.0/100.3	051	051	051	051
			CRHEATER363A00	42.4	31.8/38.9	108.6/132.9	053	053	053	053
	460-3-60	STD	CRHEATER116B00	13.9	12.8	43.6	047	047	047	047
			CRHEATER113B00	16.5	15.2	51.7	047	047	047	047
			CRHEATER114B00	27.8	25.5	87.1	047	050	050	050
			CRHEATER115B00	33.0	30.3	103.4	050	050	050	050
			CRHEATER128B00	41.7	38.3	130.7	052	052	052	052
		MED	CRHEATER116B00	13.9	12.8	43.6	047	047	047	047
			CRHEATER113B00	16.5	15.2	51.7	047	047	047	047
			CRHEATER114B00	27.8	25.5	87.1	050	050	050	050
			CRHEATER115B00	33.0	30.3	103.4	050	050	050	050
			CRHEATER128B00	41.7	38.3	130.7	052	052	052	052
		HIGH	CRHEATER116B00	13.9	12.8	43.6	047	047	047	047
			CRHEATER113B00	16.5	15.2	51.7	047	047	047	047
			CRHEATER114B00	27.8	25.5	87.1	050	050	050	050
			CRHEATER115B00	33.0	30.3	103.4	050	050	050	050
			CRHEATER128B00	41.7	38.3	130.7	052	052	052	052
	575-3-60	STD	CRHEATER118A00	18.0	16.5	56.4	047	047	047	047
			CRHEATER119A00	36.0	33.1	112.8	047	047	047	050
		MED	CRHEATER118A00	18.0	16.5	56.4	047	047	047	047
			CRHEATER119A00	36.0	33.1	112.8	047	050	047	050
		HIGH	CRHEATER118A00	18.0	16.5	56.4	047	047	047	047
			CRHEATER119A00	36.0	33.1	112.8	047	050	047	050

LEGEND

- APP PWR — 208/230v/460v/575v
- C.O. — Convenience Outlet
- IFM — Indoor Fan Motor
- NOM PWR — 240v/480v/600v
- P.E. — Power Exhaust
- Pwrdr fr/unit — Powered From Unit
- PWRD C.O. — Powered Convenience Outlet

Electrical data (cont)

548J*09 ELECTRIC HEAT — SINGLE SPEED INDOOR FAN MOTOR

UNIT	NOM. V-Ph-Hz	IFM TYPE	ELECTRIC HEATER PART NUMBER	NOM. PWR (kW)	APP PWR (kW)	APP OUTPUT (MBH)	SINGLE POINT OR JUNCTION KIT PART NUMBER			
							NO C.O. or Unpowered C.O.		w/PWRD C.O.	
							NO P.E.	w/ P.E. (pwrdr fr unit)	NO P.E.	w/ P.E. (pwrdr fr unit)
548J*09D (2-stage cooling)	208/203-3-60	STD	CRHEATER117A00	10.4	7.8/9.6	26.6/32.6	049	049	049	049
			CRHEATER110A00	16.0	12.0/14.7	41.0/50.1	049	049	049	049
			CRHEATER111A00	24.8	18.6/22.8	63.5/77.7	051	051	051	051
			CRHEATER112A00	32.0	24.0/29.4	82.0/100.3	051	051	051	051
			CRHEATER363A00	42.4	31.8/38.9	108.6/132.9	053	053	053	053
		MED	CRHEATER117A00	10.4	7.8/9.6	26.6/32.6	049	049	049	049
			CRHEATER110A00	16.0	12.0/14.7	41.0/50.1	049	049	049	049
			CRHEATER111A00	24.8	18.6/22.8	63.5/77.7	051	051	051	051
			CRHEATER112A00	32.0	24.0/29.4	82.0/100.3	051	051	051	051
			CRHEATER363A00	42.4	31.8/38.9	108.6/132.9	053	053	053	053
		HIGH	CRHEATER117A00	10.4	7.8/9.6	26.6/32.6	049	049	049	049
			CRHEATER110A00	16.0	12.0/14.7	41.0/50.1	049	049	049	049
			CRHEATER111A00	24.8	18.6/22.8	63.5/77.7	051	051	051	051
			CRHEATER112A00	32.0	24.0/29.4	82.0/100.3	051	051	051	051
			CRHEATER363A00	42.4	31.8/38.9	108.6/132.9	053	053	053	053
	460-3-60	STD	CRHEATER116B00	13.9	12.8	43.6	047	047	047	047
			CRHEATER113B00	16.5	15.2	51.7	047	047	047	047
			CRHEATER114B00	27.8	25.5	87.1	050	050	050	050
			CRHEATER115B00	33.0	30.3	103.4	050	050	050	050
			CRHEATER128B00	41.7	38.3	130.7	052	052	052	052
		MED	CRHEATER116B00	13.9	12.8	43.6	047	047	047	047
			CRHEATER113B00	16.5	15.2	51.7	047	047	047	047
			CRHEATER114B00	27.8	25.5	87.1	050	050	050	050
			CRHEATER115B00	33.0	30.3	103.4	050	050	050	050
		HIGH	CRHEATER128B00	41.7	38.3	130.7	052	052	052	052
			CRHEATER116B00	13.9	12.8	43.6	047	047	047	047
			CRHEATER113B00	16.5	15.2	51.7	047	047	047	047
			CRHEATER114B00	27.8	25.5	87.1	050	050	050	050
			CRHEATER115B00	33.0	30.3	103.4	050	050	050	050
			CRHEATER128B00	41.7	38.3	130.7	052	052	052	052
	575-3-60	STD	CRHEATER118A00	18.0	16.5	56.4	047	047	047	047
			CRHEATER119A00	36.0	33.1	112.8	047	050	050	050
		MED	CRHEATER118A00	18.0	16.5	56.4	047	047	047	047
			CRHEATER119A00	36.0	33.1	112.8	047	050	050	050
		HIGH	CRHEATER118A00	18.0	16.5	56.4	047	047	047	047
			CRHEATER119A00	36.0	33.1	112.8	047	050	050	050

LEGEND

APP PWR	— 208/230v/460v/575v
C.O.	— Convenience Outlet
IFM	— Indoor Fan Motor
NOM PWR	— 240v/480v/600v
P.E.	— Power Exhaust
Pwrdr fr/unit	— Powered From Unit
PWRD C.O.	— Powered Convenience Outlet

548J*12 ELECTRIC HEAT — SINGLE SPEED INDOOR FAN MOTOR

UNIT	NOM. V-Ph-Hz	IFM TYPE	ELECTRIC HEATER PART NUMBER	NOM. PWR (kW)	APP PWR (kW)	APP OUTPUT (MBH)	SINGLE POINT OR JUNCTION KIT PART NUMBER			
							NO C.O. or Unpowered C.O.		w/PWRD C.O.	
							NO P.E.	w/ P.E. (pwrd fr unit)	NO P.E.	w/ P.E. (pwrd fr unit)
548J*12D (2-stage cooling)	208/230-3-60	STD	CRHEATER117A00	10.4	7.8/9.6	26.6/32.6	049	049	049	049
			CRHEATER110A00	16.0	12.0/14.7	41.0/50.1	049	049	049	049
			CRHEATER112A00	32.0	24.0/29.4	82.0/100.3	051	051	051	051
			CRHEATER363A00	42.4	31.8/38.9	108.6/132.9	053	053	053	053
			CRHEATER364A00	50.0	37.6/45.9	128.1/156.7	053	053	053	053
		MED	CRHEATER117A00	10.4	7.8/9.6	26.6/32.6	049	051	051	051
			CRHEATER110A00	16.0	12.0/14.7	41.0/50.1	049	051	051	051
			CRHEATER112A00	32.0	24.0/29.4	82.0/100.3	051	053	053	053
			CRHEATER363A00	42.4	31.8/38.9	108.6/132.9	053	054	054	054
			CRHEATER364A00	50.0	37.6/45.9	128.1/156.7	053	054	054	054
		HIGH	CRHEATER117A00	10.4	7.8/9.6	26.6/32.6	049	051	051	051
			CRHEATER110A00	16.0	12.0/14.7	41.0/50.1	049	051	051	051
	CRHEATER112A00		32.0	24.0/29.4	82.0/100.3	051	053	053	053	
	CRHEATER363A00		42.4	31.8/38.9	108.6/132.9	053	054	054	054	
	CRHEATER364A00		50.0	37.6/45.9	128.1/156.7	053	054	054	054	
	460-3-60	STD	CRHEATER116B00	13.9	12.8	43.6	047	047	047	047
			CRHEATER113B00	16.5	15.2	51.7	047	047	047	047
			CRHEATER115B00	33.0	30.3	103.4	050	050	050	050
			CRHEATER128B00	41.7	38.3	130.7	052	052	052	052
			CRHEATER129B00	50.0	45.9	156.7	052	052	052	052
		MED	CRHEATER116B00	13.9	12.8	43.6	047	047	047	047
			CRHEATER113B00	16.5	15.2	51.7	047	047	047	047
			CRHEATER115B00	33.0	30.3	103.4	050	050	050	050
			CRHEATER128B00	41.7	38.3	130.7	052	052	052	052
		HIGH	CRHEATER129B00	50.0	45.9	156.7	052	052	052	052
			CRHEATER116B00	13.9	12.8	43.6	047	047	047	047
			CRHEATER113B00	16.5	15.2	51.7	047	047	047	047
	CRHEATER115B00		33.0	30.3	103.4	050	050	050	050	
	CRHEATER128B00		41.7	38.3	130.7	052	052	052	052	
	575-3-60	STD	CRHEATER118A00	18.0	16.5	56.4	047	047	047	047
			CRHEATER119A00	36.0	33.1	112.8	050	050	050	050
			CRHEATER380A00	54.0	49.6	169.2	052	052	052	052
		MED	CRHEATER118A00	18.0	16.5	56.4	047	047	047	047
			CRHEATER119A00	36.0	33.1	112.8	050	050	050	050
			CRHEATER380A00	54.0	49.6	169.2	052	052	052	052
		HIGH	CRHEATER118A00	18.0	16.5	56.4	047	047	047	047
CRHEATER119A00			36.0	33.1	112.8	050	050	050	050	
CRHEATER380A00			54.0	49.6	169.2	052	052	052	052	

LEGEND

- APP PWR** — 208/230v/460v/575v
- C.O.** — Convenience Outlet
- IFM** — Indoor Fan Motor
- NOM PWR** — 240v/480v/600v
- P.E.** — Power Exhaust
- PwrD fr/unit** — Powered From Unit
- PWRD C.O.** — Powered Convenience Outlet

Electrical data (cont)

548J*14 ELECTRIC HEAT — SINGLE SPEED INDOOR FAN MOTOR

UNIT	NOM. V-Ph-Hz	IFM TYPE	ELECTRIC HEATER PART NUMBER	NOM. PWR (kW)	APP PWR (kW)	APP OUTPUT (MBH)	SINGLE POINT OR JUNCTION KIT PART NUMBER			
							NO C.O. or Unpowered C.O.		w/PWRD C.O.	
							NO P.E.	w/ P.E. (pwrdr fr unit)	NO P.E.	w/ P.E. (pwrdr fr unit)
548J*14D (2-stage cooling)	208/230-3-60	STD	CRHEATER291A00	16.5	12.4/15.2	42.3/51.7	051	051	051	051
			CRHEATER370A00	26.5	19.9/24.3	67.9/83.0	053	053	053	053
			CRHEATER294A00	33.5	25.2/30.8	85.9/105.0	053	053	053	053
			CRHEATER367A00	43.5	32.7/40.0	111.5/136.3	054	054	054	054
			CRHEATER368A00	50.0	37.6/45.9	128.1/156.7	054	054	054	054
		MED	CRHEATER291A00	16.5	12.4/15.2	42.3/51.7	051	051	051	051
			CRHEATER370A00	26.5	19.9/24.3	67.9/83.0	053	053	053	053
			CRHEATER294A00	33.5	25.2/30.8	85.9/105.0	053	053	053	053
			CRHEATER367A00	43.5	32.7/40.0	111.5/136.3	054	054	054	054
			CRHEATER368A00	50.0	37.6/45.9	128.1/156.7	054	054	054	054
		HIGH	CRHEATER291A00	16.5	12.4/15.2	42.3/51.7	051	051	051	051
			CRHEATER370A00	26.5	19.9/24.3	67.9/83.0	053	053	053	053
			CRHEATER294A00	33.5	25.2/30.8	85.9/105.0	053	053	053	053
			CRHEATER367A00	43.5	32.7/40.0	111.5/136.3	054	054	054	054
			CRHEATER368A00	50.0	37.6/45.9	128.1/156.7	054	054	054	054
		HIGH-High Efficiency	CRHEATER291A00	16.5	12.4/15.2	42.3/51.7	051	051	051	051
			CRHEATER370A00	26.5	19.9/24.3	67.9/83.0	053	053	053	053
			CRHEATER294A00	33.5	25.2/30.8	85.9/105.0	053	053	053	053
			CRHEATER367A00	43.5	32.7/40.0	111.5/136.3	054	054	054	054
			CRHEATER368A00	50.0	37.6/45.9	128.1/156.7	054	054	054	054
	460-3-60	STD	CRHEATER292A00	16.5	15.2	51.7	047	047	047	047
			CRHEATER377A00	26.5	24.3	83.0	050	050	050	050
			CRHEATER295A00	33.5	30.8	105.0	050	050	050	050
			CRHEATER374A00	43.5	40.0	136.3	052	052	052	052
			CRHEATER375A00	50.0	45.9	156.7	052	052	052	052
		MED	CRHEATER292A00	16.5	15.2	51.7	047	047	047	047
			CRHEATER377A00	26.5	24.3	83.0	050	050	050	050
			CRHEATER295A00	33.5	30.8	105.0	050	050	050	050
			CRHEATER374A00	43.5	40.0	136.3	052	052	052	052
			CRHEATER375A00	50.0	45.9	156.7	052	052	052	052
		HIGH	CRHEATER292A00	16.5	15.2	51.7	047	050	050	050
			CRHEATER377A00	26.5	24.3	83.0	050	050	050	050
			CRHEATER295A00	33.5	30.8	105.0	050	050	050	050
			CRHEATER374A00	43.5	40.0	136.3	052	052	052	052
			CRHEATER375A00	50.0	45.9	156.7	052	052	052	052
		HIGH-High Efficiency	CRHEATER292A00	16.5	15.2	51.7	047	050	050	050
			CRHEATER377A00	26.5	24.3	83.0	050	050	050	050
			CRHEATER295A00	33.5	30.8	105.0	050	050	050	050
			CRHEATER374A00	43.5	40.0	136.3	052	052	052	052
			CRHEATER375A00	50.0	45.9	156.7	052	052	052	052

548J*14 ELECTRIC HEAT — SINGLE SPEED INDOOR FAN MOTOR (cont)

UNIT	NOM. V-Ph-Hz	IFM TYPE	ELECTRIC HEATER PART NUMBER	NOM. PWR (kW)	APP PWR (kW)	APP OUTPUT (MBH)	SINGLE POINT OR JUNCTION KIT PART NUMBER			
							NO C.O. or Unpowered C.O.		w/PWRD C.O.	
							NO P.E.	w/ P.E. (pwrd fr unit)	NO P.E.	w/ P.E. (pwrd fr unit)
548J*14D (2-stage cooling) (cont)	575-3-60	STD	CRHEATER293A00	16.5	15.2	51.7	047	047	047	047
			CRHEATER384A00	26.5	24.3	83.0	047	047	047	050
			CRHEATER296A00	33.5	30.8	105.0	050	050	050	050
			CRHEATER381A00	43.5	40.0	136.3	052	052	052	052
			CRHEATER382A00	50.0	45.9	156.7	052	052	052	052
		MED	CRHEATER293A00	16.5	15.2	51.7	047	047	047	047
			CRHEATER384A00	26.5	24.3	83.0	047	047	047	050
			CRHEATER296A00	33.5	30.8	105.0	050	050	050	050
			CRHEATER381A00	43.5	40.0	136.3	052	052	052	052
			CRHEATER382A00	50.0	45.9	156.7	052	052	052	052
		HIGH	CRHEATER293A00	16.5	15.2	51.7	047	047	047	047
			CRHEATER384A00	26.5	24.3	83.0	047	050	050	050
			CRHEATER296A00	33.5	30.8	105.0	050	050	050	050
			CRHEATER381A00	43.5	40.0	136.3	052	052	052	052
			CRHEATER382A00	50.0	45.9	156.7	052	052	052	052
		HIGH-High Efficiency	CRHEATER293A00	16.5	15.2	51.7	047	047	047	047
			CRHEATER384A00	26.5	24.3	83.0	050	050	050	050
			CRHEATER296A00	33.5	30.8	105.0	050	050	050	050
			CRHEATER381A00	43.5	40.0	136.3	052	052	052	052
			CRHEATER382A00	50.0	45.9	156.7	052	052	052	052

LEGEND

- APP PWR** — 208/23v0/460v/575v
- C.O.** — Convenience Outlet
- IFM** — Indoor Fan Motor
- NOM PWR** — 240v/480v/600v
- P.E.** — Power Exhaust
- PwrD fr/unit** — Powered From Unit
- PWRD C.O.** — Powered Convenience Outlet

Electrical data (cont)

548J*07 ELECTRIC HEAT — SINGLE SPEED INDOOR FAN MOTOR WITH NON-FUSED DISCONNECT

UNIT	NOM. V-Ph-Hz	IFM TYPE	ELECTRIC HEATER PART NUMBER	NOM. PWR (kW)	APP PWR (kW)	APP OUTPUT (MBH)	SINGLE POINT OR JUNCTION KIT PART NUMBER			
							NO C.O. or Unpowered C.O.		w/PWRD C.O.	
							NO P.E.	w/ P.E. (pwrdr fr unit)	NO P.E.	w/ P.E. (pwrdr fr unit)
548J*07A	208/230-3-60	STD	CRHEATER102A00	6.5	4.9/6.0	16.7/20.4	037	037	037	037
			CRHEATER104B00	10.5	7.9/9.6	26.9/32.9	038	038	038	038
			CRHEATER105A00	16.0	12.0/14.7	41.0/50.1	038	038	038	038
			CRHEATER361A00	21.0	15.8/19.3	53.8/65.8	039	039	039	039
			CRHEATER362A00	26.5	19.9/24.3	67.9/83.0	039	039	039	039
		MED	CRHEATER102A00	6.5	4.9/6.0	16.7/20.4	037	037	037	038
			CRHEATER104B00	10.5	7.9/9.6	26.9/32.9	038	038	038	038
			CRHEATER105A00	16.0	12.0/14.7	41.0/50.1	038	038	038	038
			CRHEATER361A00	21.0	15.8/19.3	53.8/65.8	039	039	039	039
			CRHEATER362A00	26.5	19.9/24.3	67.9/83.0	039	039	039	039
		HIGH	CRHEATER102A00	6.5	4.9/6.0	16.7/20.4	037	037	037	038
			CRHEATER104B00	10.5	7.9/9.6	26.9/32.9	038	038	038	038
	CRHEATER105A00		16.0	12.0/14.7	41.0/50.1	038	038	038	038	
	CRHEATER361A00		21.0	15.8/19.3	53.8/65.8	039	039	039	039	
	460-3-60	STD	CRHEATER106A00	6.0	5.5	18.8	—	—	—	—
			CRHEATER108A00	11.5	10.6	36.0	—	—	—	—
			CRHEATER109A00	14.0	12.9	43.9	—	—	—	—
			CRHEATER372A00	23.0	21.1	72.1	037	037	037	037
			CRHEATER373A00	25.5	23.4	79.9	037	037	037	037
		MED	CRHEATER106A00	6.0	5.5	18.8	—	—	—	—
			CRHEATER108A00	11.5	10.6	36.0	—	—	—	—
			CRHEATER109A00	14.0	12.9	43.9	—	—	—	—
			CRHEATER372A00	23.0	21.1	72.1	037	037	037	037
		HIGH	CRHEATER373A00	25.5	23.4	79.9	037	037	037	037
CRHEATER106A00			6.0	5.5	18.8	—	—	—	—	
CRHEATER108A00			11.5	10.6	36.0	—	—	—	—	
CRHEATER109A00	14.0		12.9	43.9	—	—	—	—		
CRHEATER372A00	23.0		21.1	72.1	037	037	037	037		
CRHEATER373A00	25.5	23.4	79.9	037	037	037	037			

LEGEND

—	No Single Point Kit required
APP PWR	208/230v/460v/575v
C.O.	Convenience Outlet
IFM	Indoor Fan Motor
NOM PWR	240v/480v/600v
P.E.	Power Exhaust
Pwrdr fr/unit	Powered From Unit
PWRD C.O.	Powered Convenience Outlet

548J*08 ELECTRIC HEAT — SINGLE SPEED INDOOR FAN MOTOR WITH NON-FUSED DISCONNECT

UNIT	NOM. V-Ph-Hz	IFM TYPE	ELECTRIC HEATER PART NUMBER	NOM. PWR (kW)	APP PWR (kW)	APP OUTPUT (MBH)	SINGLE POINT OR JUNCTION KIT PART NUMBER				
							NO C.O. or Unpowered C.O.		w/PWRD C.O.		
							NO P.E.	w/ P.E. (pwrdr fr unit)	NO P.E.	w/ P.E. (pwrdr fr unit)	
548J*08D (2-stage cooling)	208/230-3-60	STD	CRHEATER117A00	10.4	7.8/9.6	26.6/32.6	049	049	049	049	
			CRHEATER110A00	16.0	12.0/14.7	41.0/50.1	049	049	049	049	
			CRHEATER111A00	24.8	18.6/22.8	63.5/77.7	051	051	051	051	
			CRHEATER112A00	32.0	24.0/29.4	82.0/100.3	051	051	051	051	
			CRHEATER363A00	42.4	31.8/38.9	108.6/132.9	053	053	053	053	
		MED	CRHEATER117A00	10.4	7.8/9.6	26.6/32.6	049	049	049	049	
			CRHEATER110A00	16.0	12.0/14.7	41.0/50.1	049	049	049	049	
			CRHEATER111A00	24.8	18.6/22.8	63.5/77.7	051	051	051	051	
			CRHEATER112A00	32.0	24.0/29.4	82.0/100.3	051	051	051	051	
			CRHEATER363A00	42.4	31.8/38.9	108.6/132.9	053	053	053	053	
		HIGH	CRHEATER117A00	10.4	7.8/9.6	26.6/32.6	049	049	049	049	
			CRHEATER110A00	16.0	12.0/14.7	41.0/50.1	049	049	049	049	
			CRHEATER111A00	24.8	18.6/22.8	63.5/77.7	051	051	051	051	
			CRHEATER112A00	32.0	24.0/29.4	82.0/100.3	051	051	051	051	
			CRHEATER363A00	42.4	31.8/38.9	108.6/132.9	053	053	053	053	
		460-3-60	STD	CRHEATER116B00	13.9	12.8	43.6	047	047	047	047
				CRHEATER113B00	16.5	15.2	51.7	047	047	047	047
				CRHEATER114B00	27.8	25.5	87.1	047	050	050	050
	CRHEATER115B00			33.0	30.3	103.4	050	050	050	050	
	CRHEATER128B00			41.7	38.3	130.7	052	052	052	052	
	MED		CRHEATER116B00	13.9	12.8	43.6	047	047	047	047	
			CRHEATER113B00	16.5	15.2	51.7	047	047	047	047	
			CRHEATER114B00	27.8	25.5	87.1	050	050	050	050	
			CRHEATER115B00	33.0	30.3	103.4	050	050	050	050	
			CRHEATER128B00	41.7	38.3	130.7	052	052	052	052	
	HIGH		CRHEATER116B00	13.9	12.8	43.6	047	047	047	047	
			CRHEATER113B00	16.5	15.2	51.7	047	047	047	047	
			CRHEATER114B00	27.8	25.5	87.1	050	050	050	050	
			CRHEATER115B00	33.0	30.3	103.4	050	050	050	050	
			CRHEATER128B00	41.7	38.3	130.7	052	052	052	052	
	575-3-60		STD	CRHEATER118A00	18.0	16.5	56.4	047	047	047	047
				CRHEATER119A00	36.0	33.1	112.8	047	047	047	050
			MED	CRHEATER118A00	18.0	16.5	56.4	047	047	047	047
		CRHEATER119A00		36.0	33.1	112.8	047	050	047	050	
		HIGH	CRHEATER118A00	18.0	16.5	56.4	047	047	047	047	
			CRHEATER119A00	36.0	33.1	112.8	047	050	047	050	

LEGEND
APP PWR — 208/230v/460v/575v
C.O. — Convenience Outlet
IFM — Indoor Fan Motor
NOM PWR — 240v/480v/600v
P.E. — Power Exhaust
Pwrdr fr/unit — Powered From Unit
PWRD C.O. — Powered Convenience Outlet

Electrical data (cont)

548J*09 ELECTRIC HEAT — SINGLE SPEED INDOOR FAN MOTOR WITH NON-FUSED DISCONNECT

UNIT	NOM. V-Ph-Hz	IFM TYPE	ELECTRIC HEATER PART NUMBER	NOM. PWR (kW)	APP PWR (kW)	APP OUTPUT (MBH)	SINGLE POINT OR JUNCTION KIT PART NUMBER				
							NO C.O. or Unpowered C.O.		w/PWRD C.O.		
							NO P.E.	w/ P.E. (pwrdr fr unit)	NO P.E.	w/ P.E. (pwrdr fr unit)	
548J*09D (2-stage cooling)	208/203-3-60	STD	CRHEATER117A00	10.4	7.8/9.6	26.6/32.6	049	049	049	049	
			CRHEATER110A00	16.0	12.0/14.7	41.0/50.1	049	049	049	049	
			CRHEATER111A00	24.8	18.6/22.8	63.5/77.7	051	051	051	051	
			CRHEATER112A00	32.0	24.0/29.4	82.0/100.3	051	051	051	051	
			CRHEATER363A00	42.4	31.8/38.9	108.6/132.9	053	053	053	053	
		MED	CRHEATER117A00	10.4	7.8/9.6	26.6/32.6	049	049	049	049	
			CRHEATER110A00	16.0	12.0/14.7	41.0/50.1	049	049	049	049	
			CRHEATER111A00	24.8	18.6/22.8	63.5/77.7	051	051	051	051	
			CRHEATER112A00	32.0	24.0/29.4	82.0/100.3	051	051	051	051	
			CRHEATER363A00	42.4	31.8/38.9	108.6/132.9	053	053	053	053	
		HIGH	CRHEATER117A00	10.4	7.8/9.6	26.6/32.6	049	049	049	049	
			CRHEATER110A00	16.0	12.0/14.7	41.0/50.1	049	049	049	049	
			CRHEATER111A00	24.8	18.6/22.8	63.5/77.7	051	051	051	051	
			CRHEATER112A00	32.0	24.0/29.4	82.0/100.3	051	051	051	051	
			CRHEATER363A00	42.4	31.8/38.9	108.6/132.9	053	053	053	053	
	460-3-60	STD	CRHEATER116B00	13.9	12.8	43.6	047	047	047	047	
			CRHEATER113B00	16.5	15.2	51.7	047	047	047	047	
			CRHEATER114B00	27.8	25.5	87.1	050	050	050	050	
			CRHEATER115B00	33.0	30.3	103.4	050	050	050	050	
			CRHEATER128B00	41.7	38.3	130.7	052	052	052	052	
		MED	CRHEATER116B00	13.9	12.8	43.6	047	047	047	047	
			CRHEATER113B00	16.5	15.2	51.7	047	047	047	047	
			CRHEATER114B00	27.8	25.5	87.1	050	050	050	050	
			CRHEATER115B00	33.0	30.3	103.4	050	050	050	050	
		HIGH	CRHEATER128B00	41.7	38.3	130.7	052	052	052	052	
			CRHEATER116B00	13.9	12.8	43.6	047	047	047	047	
			CRHEATER113B00	16.5	15.2	51.7	047	047	047	047	
			CRHEATER114B00	27.8	25.5	87.1	050	050	050	050	
		575-3-60	STD	CRHEATER118A00	18.0	16.5	56.4	047	047	047	047
				CRHEATER119A00	36.0	33.1	112.8	047	050	050	050
	MED		CRHEATER118A00	18.0	16.5	56.4	047	047	047	047	
			CRHEATER119A00	36.0	33.1	112.8	047	050	050	050	
	HIGH		CRHEATER118A00	18.0	16.5	56.4	047	047	047	047	
			CRHEATER119A00	36.0	33.1	112.8	047	050	050	050	

LEGEND

APP PWR	— 208/230v/460v/575v
C.O.	— Convenience Outlet
IFM	— Indoor Fan Motor
NOM PWR	— 240v/480v/600v
P.E.	— Power Exhaust
Pwrdr fr/unit	— Powered From Unit
PWRD C.O.	— Powered Convenience Outlet

548J*12 ELECTRIC HEAT — SINGLE SPEED INDOOR FAN MOTOR WITH NON-FUSED DISCONNECT

UNIT	NOM. V-Ph-Hz	IFM TYPE	ELECTRIC HEATER PART NUMBER	NOM. PWR (kW)	APP PWR (kW)	APP OUTPUT (MBH)	SINGLE POINT OR JUNCTION KIT PART NUMBER			
							NO C.O. or Unpowered C.O.		w/PWRD C.O.	
							NO P.E.	w/ P.E. (pwrd fr unit)	NO P.E.	w/ P.E. (pwrd fr unit)
548J*12D (2-stage cooling)	208/230-3-60	STD	CRHEATER117A00	10.4	7.8/9.6	26.6/32.6	049	049	049	049
			CRHEATER110A00	16.0	12.0/14.7	41.0/50.1	049	049	049	049
			CRHEATER112A00	32.0	24.0/29.4	82.0/100.3	051	051	051	051
			CRHEATER363A00	42.4	31.8/38.9	108.6/132.9	053	053	053	053
			CRHEATER364A00	50.0	37.6/45.9	128.1/156.7	053	053	053	053
		MED	CRHEATER117A00	10.4	7.8/9.6	26.6/32.6	049	051	051	051
			CRHEATER110A00	16.0	12.0/14.7	41.0/50.1	049	051	051	051
			CRHEATER112A00	32.0	24.0/29.4	82.0/100.3	051	053	053	053
			CRHEATER363A00	42.4	31.8/38.9	108.6/132.9	053	054	054	054
			CRHEATER364A00	50.0	37.6/45.9	128.1/156.7	053	054	054	054
		HIGH	CRHEATER117A00	10.4	7.8/9.6	26.6/32.6	049	051	051	051
			CRHEATER110A00	16.0	12.0/14.7	41.0/50.1	049	051	051	051
	CRHEATER112A00		32.0	24.0/29.4	82.0/100.3	051	053	053	053	
	CRHEATER363A00		42.4	31.8/38.9	108.6/132.9	053	054	054	054	
	CRHEATER364A00		50.0	37.6/45.9	128.1/156.7	053	054	054	054	
	460-3-60	STD	CRHEATER116B00	13.9	12.8	43.6	047	047	047	047
			CRHEATER113B00	16.5	15.2	51.7	047	047	047	047
			CRHEATER115B00	33.0	30.3	103.4	050	050	050	050
			CRHEATER128B00	41.7	38.3	130.7	052	052	052	052
			CRHEATER129B00	50.0	45.9	156.7	052	052	052	052
		MED	CRHEATER116B00	13.9	12.8	43.6	047	047	047	047
			CRHEATER113B00	16.5	15.2	51.7	047	047	047	047
			CRHEATER115B00	33.0	30.3	103.4	050	050	050	050
			CRHEATER128B00	41.7	38.3	130.7	052	052	052	052
		HIGH	CRHEATER129B00	50.0	45.9	156.7	052	052	052	052
			CRHEATER116B00	13.9	12.8	43.6	047	047	047	047
			CRHEATER113B00	16.5	15.2	51.7	047	047	047	047
	CRHEATER115B00		33.0	30.3	103.4	050	050	050	050	
	CRHEATER128B00		41.7	38.3	130.7	052	052	052	052	
	575-3-60	STD	CRHEATER118A00	18.0	16.5	56.4	047	047	047	047
			CRHEATER119A00	36.0	33.1	112.8	050	050	050	050
			CRHEATER380A00	54.0	49.6	169.2	052	052	052	052
		MED	CRHEATER118A00	18.0	16.5	56.4	047	047	047	047
			CRHEATER119A00	36.0	33.1	112.8	050	050	050	050
			CRHEATER380A00	54.0	49.6	169.2	052	052	052	052
		HIGH	CRHEATER118A00	18.0	16.5	56.4	047	047	047	047
CRHEATER119A00			36.0	33.1	112.8	050	050	050	050	
CRHEATER380A00			54.0	49.6	169.2	052	052	052	052	

LEGEND

- APP PWR** — 208/230v/460v/575v
- C.O.** — Convenience Outlet
- IFM** — Indoor Fan Motor
- NOM PWR** — 240v/480v/600v
- P.E.** — Power Exhaust
- PwrD fr/unit** — Powered From Unit
- PWRD C.O.** — Powered Convenience Outlet

Electrical data (cont)

548J*14 ELECTRIC HEAT — SINGLE SPEED INDOOR FAN MOTOR WITH NON-FUSED DISCONNECT

UNIT	NOM. V-Ph-Hz	IFM TYPE	ELECTRIC HEATER PART NUMBER	NOM. PWR (kW)	APP PWR (kW)	APP OUTPUT (MBH)	SINGLE POINT OR JUNCTION KIT PART NUMBER			
							NO C.O. or Unpowered C.O.		w/PWRD C.O.	
							NO P.E.	w/ P.E. (pwrdd fr unit)	NO P.E.	w/ P.E. (pwrdd fr unit)
548J*14D (2-stage cooling)	208/230-3-60	STD	CRHEATER291A00	16.5	12.4/15.2	42.3/51.7	051	051	051	051
			CRHEATER370A00	26.5	19.9/24.3	67.9/83.0	053	053	053	053
			CRHEATER294A00	33.5	25.2/30.8	85.9/105.0	053	053	053	053
			CRHEATER367A00	43.5	32.7/40.0	111.5/136.3	054	054	054	054
			CRHEATER368A00	50.0	37.6/45.9	128.1/156.7	054	054	054	054
		MED	CRHEATER291A00	16.5	12.4/15.2	42.3/51.7	051	051	051	051
			CRHEATER370A00	26.5	19.9/24.3	67.9/83.0	053	053	053	053
			CRHEATER294A00	33.5	25.2/30.8	85.9/105.0	053	053	053	053
			CRHEATER367A00	43.5	32.7/40.0	111.5/136.3	054	054	054	054
			CRHEATER368A00	50.0	37.6/45.9	128.1/156.7	054	054	054	054
		HIGH	CRHEATER291A00	16.5	12.4/15.2	42.3/51.7	051	051	051	051
			CRHEATER370A00	26.5	19.9/24.3	67.9/83.0	053	053	053	053
			CRHEATER294A00	33.5	25.2/30.8	85.9/105.0	053	053	053	053
			CRHEATER367A00	43.5	32.7/40.0	111.5/136.3	054	054	054	054
			CRHEATER368A00	50.0	37.6/45.9	128.1/156.7	054	054	054	054
		HIGH-High Efficiency	CRHEATER291A00	16.5	12.4/15.2	42.3/51.7	051	051	051	051
			CRHEATER370A00	26.5	19.9/24.3	67.9/83.0	053	053	053	053
			CRHEATER294A00	33.5	25.2/30.8	85.9/105.0	053	053	053	053
	CRHEATER367A00		43.5	32.7/40.0	111.5/136.3	054	054	054	054	
	CRHEATER368A00		50.0	37.6/45.9	128.1/156.7	054	054	054	054	
	460-3-60	STD	CRHEATER292A00	16.5	15.2	51.7	047	047	047	047
			CRHEATER377A00	26.5	24.3	83.0	050	050	050	050
			CRHEATER295A00	33.5	30.8	105.0	050	050	050	050
			CRHEATER374A00	43.5	40.0	136.3	052	052	052	052
			CRHEATER375A00	50.0	45.9	156.7	052	052	052	052
		MED	CRHEATER292A00	16.5	15.2	51.7	047	047	047	047
			CRHEATER377A00	26.5	24.3	83.0	050	050	050	050
			CRHEATER295A00	33.5	30.8	105.0	050	050	050	050
			CRHEATER374A00	43.5	40.0	136.3	052	052	052	052
			CRHEATER375A00	50.0	45.9	156.7	052	052	052	052
		HIGH	CRHEATER292A00	16.5	15.2	51.7	047	050	050	050
			CRHEATER377A00	26.5	24.3	83.0	050	050	050	050
			CRHEATER295A00	33.5	30.8	105.0	050	050	050	050
			CRHEATER374A00	43.5	40.0	136.3	052	052	052	052
			CRHEATER375A00	50.0	45.9	156.7	052	052	052	052
		HIGH-High Efficiency	CRHEATER292A00	16.5	15.2	51.7	047	050	050	050
CRHEATER377A00			26.5	24.3	83.0	050	050	050	050	
CRHEATER295A00			33.5	30.8	105.0	050	050	050	050	
CRHEATER374A00	43.5		40.0	136.3	052	052	052	052		
CRHEATER375A00	50.0		45.9	156.7	052	052	052	052		

548J*14 ELECTRIC HEAT — SINGLE SPEED INDOOR FAN MOTOR WITH NON-FUSED DISCONNECT (cont)

UNIT	NOM. V-Ph-Hz	IFM TYPE	ELECTRIC HEATER PART NUMBER	NOM. PWR (kW)	APP PWR (kW)	APP OUTPUT (MBH)	SINGLE POINT OR JUNCTION KIT PART NUMBER			
							NO C.O. or Unpowered C.O.		w/PWRD C.O.	
							NO P.E.	w/ P.E. (pwrd fr unit)	NO P.E.	w/ P.E. (pwrd fr unit)
548J*14D (2-stage cooling) (cont)	575-3-60	STD	CRHEATER293A00	16.5	15.2	51.7	047	047	047	047
			CRHEATER384A00	26.5	24.3	83.0	047	047	047	050
			CRHEATER296A00	33.5	30.8	105.0	050	050	050	050
			CRHEATER381A00	43.5	40.0	136.3	052	052	052	052
			CRHEATER382A00	50.0	45.9	156.7	052	052	052	052
		MED	CRHEATER293A00	16.5	15.2	51.7	047	047	047	047
			CRHEATER384A00	26.5	24.3	83.0	047	047	047	050
			CRHEATER296A00	33.5	30.8	105.0	050	050	050	050
			CRHEATER381A00	43.5	40.0	136.3	052	052	052	052
		HIGH	CRHEATER382A00	50.0	45.9	156.7	052	052	052	052
			CRHEATER293A00	16.5	15.2	51.7	047	047	047	047
			CRHEATER384A00	26.5	24.3	83.0	047	050	050	050
			CRHEATER296A00	33.5	30.8	105.0	050	050	050	050
			CRHEATER381A00	43.5	40.0	136.3	052	052	052	052
		HIGH-High Efficiency	CRHEATER382A00	50.0	45.9	156.7	052	052	052	052
			CRHEATER293A00	16.5	15.2	51.7	047	047	047	047
			CRHEATER384A00	26.5	24.3	83.0	050	050	050	050
			CRHEATER296A00	33.5	30.8	105.0	050	050	050	050
			CRHEATER381A00	43.5	40.0	136.3	052	052	052	052
					CRHEATER382A00	50.0	45.9	156.7	052	052

LEGEND

- APP PWR — 208/23v0/460v/575v
- C.O. — Convenience Outlet
- IFM — Indoor Fan Motor
- NOM PWR — 240v/480v/600v
- P.E. — Power Exhaust
- PwrD fr/unit — Powered From Unit
- PWRD C.O. — Powered Convenience Outlet

Electrical data (cont)

548J*07 ELECTRIC HEAT — TWO-SPEED INDOOR FAN MOTOR

UNIT	NOM. V-Ph-Hz	IFM TYPE	ELECTRIC HEATER PART NUMBER	NOM. PWR (kW)	APP PWR (kW)	APP OUTPUT (MBH)	SINGLE POINT OR JUNCTION KIT PART NUMBER			
							NO C.O. or Unpowered C.O.		w/PWRD C.O.	
							NO P.E.	w/ P.E. (pwrdr fr unit)	NO P.E.	w/ P.E. (pwrdr fr unit)
548J*07A	208/230-3-60	STD	CRHEATER102A00	6.5	4.9/6.0	16.7/20.4	037	037	037	037
			CRHEATER104B00	10.5	7.9/9.6	26.9/32.9	038	038	038	038
			CRHEATER105A00	16.0	12.0/14.7	41.0/50.1	038	038	038	038
			CRHEATER361A00	21.0	15.8/19.3	53.8/65.8	039	039	039	039
			CRHEATER362A00	26.5	19.9/24.3	67.9/83.0	039	039	039	039
		MED	CRHEATER102A00	6.5	4.9/6.0	16.7/20.4	037	037	037	038
			CRHEATER104B00	10.5	7.9/9.6	26.9/32.9	038	038	038	038
			CRHEATER105A00	16.0	12.0/14.7	41.0/50.1	038	038	038	038
			CRHEATER361A00	21.0	15.8/19.3	53.8/65.8	039	039	039	039
			CRHEATER362A00	26.5	19.9/24.3	67.9/83.0	039	039	039	039
		HIGH	CRHEATER102A00	6.5	4.9/6.0	16.7/20.4	037	037	038	038
			CRHEATER104B00	10.5	7.9/9.6	26.9/32.9	038	038	038	038
			CRHEATER105A00	16.0	12.0/14.7	41.0/50.1	038	038	038	038
			CRHEATER361A00	21.0	15.8/19.3	53.8/65.8	039	039	039	039
			CRHEATER362A00	26.5	19.9/24.3	67.9/83.0	039	039	039	039
	460-3-60	STD	CRHEATER106A00	6.0	5.5	18.8	—	—	—	—
			CRHEATER108A00	11.5	10.6	36.0	—	—	—	—
			CRHEATER109A00	14.0	12.9	43.9	—	—	—	—
			CRHEATER372A00	23.0	21.1	72.1	037	037	037	037
			CRHEATER373A00	25.5	23.4	79.9	037	037	037	037
		MED	CRHEATER106A00	6.0	5.5	18.8	—	—	—	—
			CRHEATER108A00	11.5	10.6	36.0	—	—	—	—
			CRHEATER109A00	14.0	12.9	43.9	—	—	—	—
			CRHEATER372A00	23.0	21.1	72.1	037	037	037	037
CRHEATER373A00			25.5	23.4	79.9	037	037	037	037	
HIGH		CRHEATER106A00	6.0	5.5	18.8	—	—	—	—	
		CRHEATER108A00	11.5	10.6	36.0	—	—	—	—	
		CRHEATER109A00	14.0	12.9	43.9	—	—	—	—	
		CRHEATER372A00	23.0	21.1	72.1	037	037	037	037	
		CRHEATER373A00	25.5	23.4	79.9	037	037	037	037	

LEGEND

—	No Single Point Kit required
APP PWR	208/230v/460v/575v
C.O.	Convenience Outlet
IFM	Indoor Fan Motor
NOM PWR	240v/480v/600v
P.E.	Power Exhaust
Pwrdr fr/unit	Powered From Unit
PWRD C.O.	Powered Convenience Outlet

548J*08 ELECTRIC HEAT — TWO-SPEED INDOOR FAN MOTOR

UNIT	NOM. V-Ph-Hz	IFM TYPE	ELECTRIC HEATER PART NUMBER	NOM. PWR (kW)	APP PWR (kW)	APP OUTPUT (MBH)	SINGLE POINT OR JUNCTION KIT PART NUMBER			
							NO C.O. or Unpowered C.O.		w/PWRD C.O.	
							NO P.E.	w/ P.E. (pwrdr fr unit)	NO P.E.	w/ P.E. (pwrdr fr unit)
548J*08D	208/230-3-60	STD	CRHEATER117A00	10.4	7.8/9.6	26.6/32.6	049	049	049	049
			CRHEATER110A00	16.0	12.0/14.7	41.0/50.1	049	049	049	049
			CRHEATER111A00	24.8	18.6/22.8	63.5/77.7	051	051	051	051
			CRHEATER112A00	32.0	24.0/29.4	82.0/100.3	051	051	051	051
			CRHEATER363A00	42.4	31.8/38.9	108.6/132.9	053	053	053	053
		MED	CRHEATER117A00	10.4	7.8/9.6	26.6/32.6	049	049	049	049
			CRHEATER110A00	16.0	12.0/14.7	41.0/50.1	049	049	049	049
			CRHEATER111A00	24.8	18.6/22.8	63.5/77.7	051	051	051	051
			CRHEATER112A00	32.0	24.0/29.4	82.0/100.3	051	051	051	051
			CRHEATER363A00	42.4	31.8/38.9	108.6/132.9	053	053	053	053
		HIGH	CRHEATER117A00	10.4	7.8/9.6	26.6/32.6	049	049	049	049
			CRHEATER110A00	16.0	12.0/14.7	41.0/50.1	049	049	049	049
	CRHEATER111A00		24.8	18.6/22.8	63.5/77.7	051	051	051	051	
	CRHEATER112A00		32.0	24.0/29.4	82.0/100.3	051	051	051	051	
	CRHEATER363A00		42.4	31.8/38.9	108.6/132.9	053	053	053	053	
	460-3-60	STD	CRHEATER116B00	13.9	12.8	43.6	047	047	047	047
			CRHEATER113B00	16.5	15.2	51.7	047	047	047	047
			CRHEATER114B00	27.8	25.5	87.1	047	050	050	050
			CRHEATER115B00	33.0	30.3	103.4	050	050	050	050
			CRHEATER128B00	41.7	38.3	130.7	052	052	052	052
		MED	CRHEATER116B00	13.9	12.8	43.6	047	047	047	047
			CRHEATER113B00	16.5	15.2	51.7	047	047	047	047
			CRHEATER114B00	27.8	25.5	87.1	050	050	050	050
			CRHEATER115B00	33.0	30.3	103.4	050	050	050	050
		HIGH	CRHEATER128B00	41.7	38.3	130.7	052	052	052	052
			CRHEATER116B00	13.9	12.8	43.6	047	047	047	047
			CRHEATER113B00	16.5	15.2	51.7	047	047	047	047
	575-3-60	STD	CRHEATER118A00	18.0	16.5	56.4	047	047	047	047
			CRHEATER119A00	36.0	33.1	112.8	047	050	047	050
			CRHEATER118A00	18.0	16.5	56.4	047	047	047	047
		MED	CRHEATER119A00	36.0	33.1	112.8	047	050	050	050
			CRHEATER118A00	18.0	16.5	56.4	047	047	047	047
	HIGH	CRHEATER119A00	36.0	33.1	112.8	047	050	050	050	

LEGEND

- APP PWR** — 208/230v/460v/575v
- C.O.** — Convenience Outlet
- IFM** — Indoor Fan Motor
- NOM PWR** — 240v/480v/600v
- P.E.** — Power Exhaust
- Pwrdr fr/unit** — Powered From Unit
- PWRD C.O.** — Powered Convenience Outlet

Electrical data (cont)

548J*09 ELECTRIC HEAT — TWO-SPEED INDOOR FAN MOTOR

UNIT	NOM. V-Ph-Hz	IFM TYPE	ELECTRIC HEATER PART NUMBER	NOM. PWR (kW)	APP PWR (kW)	APP OUTPUT (MBH)	SINGLE POINT OR JUNCTION KIT PART NUMBER				
							NO C.O. or Unpowered C.O.		w/PWRD C.O.		
							NO P.E.	w/ P.E. (pwrd fr unit)	NO P.E.	w/ P.E. (pwrd fr unit)	
548J*09D	208/203-3-60	STD	CRHEATER117A00	10.4	7.8/9.6	26.6/32.6	049	049	049	049	
			CRHEATER110A00	16.0	12.0/14.7	41.0/50.1	049	049	049	049	
			CRHEATER111A00	24.8	18.6/22.8	63.5/77.7	051	051	051	051	
			CRHEATER112A00	32.0	24.0/29.4	82.0/100.3	051	051	051	051	
			CRHEATER363A00	42.4	31.8/38.9	108.6/132.9	053	053	053	053	
		MED	CRHEATER117A00	10.4	7.8/9.6	26.6/32.6	049	049	049	049	
			CRHEATER110A00	16.0	12.0/14.7	41.0/50.1	049	049	049	049	
			CRHEATER111A00	24.8	18.6/22.8	63.5/77.7	051	051	051	051	
			CRHEATER112A00	32.0	24.0/29.4	82.0/100.3	051	051	051	051	
			CRHEATER363A00	42.4	31.8/38.9	108.6/132.9	053	053	053	053	
		HIGH	CRHEATER117A00	10.4	7.8/9.6	26.6/32.6	049	049	049	049	
			CRHEATER110A00	16.0	12.0/14.7	41.0/50.1	049	049	049	049	
			CRHEATER111A00	24.8	18.6/22.8	63.5/77.7	051	051	051	051	
			CRHEATER112A00	32.0	24.0/29.4	82.0/100.3	051	051	051	051	
			CRHEATER363A00	42.4	31.8/38.9	108.6/132.9	053	053	053	053	
	460-3-60	STD	CRHEATER116B00	13.9	12.8	43.6	047	047	047	047	
			CRHEATER113B00	16.5	15.2	51.7	047	047	047	047	
			CRHEATER114B00	27.8	25.5	87.1	050	050	050	050	
			CRHEATER115B00	33.0	30.3	103.4	050	050	050	050	
			CRHEATER128B00	41.7	38.3	130.7	052	052	052	052	
		MED	CRHEATER116B00	13.9	12.8	43.6	047	047	047	047	
			CRHEATER113B00	16.5	15.2	51.7	047	047	047	047	
			CRHEATER114B00	27.8	25.5	87.1	050	050	050	050	
			CRHEATER115B00	33.0	30.3	103.4	050	050	050	050	
		HIGH	CRHEATER128B00	41.7	38.3	130.7	052	052	052	052	
			CRHEATER116B00	13.9	12.8	43.6	047	047	047	047	
			CRHEATER113B00	16.5	15.2	51.7	047	047	047	047	
			CRHEATER114B00	27.8	25.5	87.1	050	050	050	050	
		575-3-60	STD	CRHEATER118A00	18.0	16.5	56.4	047	047	047	047
				CRHEATER119A00	36.0	33.1	112.8	047	050	050	050
	MED		CRHEATER118A00	18.0	16.5	56.4	047	047	047	047	
			CRHEATER119A00	36.0	33.1	112.8	050	050	050	050	
	HIGH		CRHEATER118A00	18.0	16.5	56.4	047	047	047	047	
			CRHEATER119A00	36.0	33.1	112.8	050	050	050	050	

LEGEND

APP PWR	— 208/23v0/460v/575v
C.O.	— Convenience Outlet
IFM	— Indoor Fan Motor
NOM PWR	— 240v/480v/600v
P.E.	— Power Exhaust
Pwr'd fr/unit	— Powered From Unit
PWRD C.O.	— Powered Convenience Outlet

548J*12 ELECTRIC HEAT — TWO-SPEED INDOOR FAN MOTOR

UNIT	NOM. V-Ph-Hz	IFM TYPE	ELECTRIC HEATER PART NUMBER	NOM. PWR (kW)	APP PWR (kW)	APP OUTPUT (MBH)	SINGLE POINT OR JUNCTION KIT PART NUMBER			
							NO C.O. or Unpowered C.O.		w/PWRD C.O.	
							NO P.E.	w/ P.E. (pwrd fr unit)	NO P.E.	w/ P.E. (pwrd fr unit)
548J*12D	208/230-3-60	STD	CRHEATER117A00	10.4	7.8/9.6	26.6/32.6	049	049	049	051
			CRHEATER110A00	16.0	12.0/14.7	41.0/50.1	049	049	049	051
			CRHEATER112A00	32.0	24.0/29.4	82.0/100.3	051	051	051	053
			CRHEATER363A00	42.4	31.8/38.9	108.6/132.9	053	053	053	054
			CRHEATER364A00	50.0	37.6/45.9	128.1/156.7	053	053	053	054
		MED	CRHEATER117A00	10.4	7.8/9.6	26.6/32.6	049	051	051	051
			CRHEATER110A00	16.0	12.0/14.7	41.0/50.1	049	051	051	051
			CRHEATER112A00	32.0	24.0/29.4	82.0/100.3	051	053	053	053
			CRHEATER363A00	42.4	31.8/38.9	108.6/132.9	053	054	054	054
			CRHEATER364A00	50.0	37.6/45.9	128.1/156.7	053	054	054	054
		HIGH	CRHEATER117A00	10.4	7.8/9.6	26.6/32.6	049	051	051	051
			CRHEATER110A00	16.0	12.0/14.7	41.0/50.1	049	051	051	051
	CRHEATER112A00		32.0	24.0/29.4	82.0/100.3	051	053	053	053	
	CRHEATER363A00		42.4	31.8/38.9	108.6/132.9	053	054	054	054	
	CRHEATER364A00		50.0	37.6/45.9	128.1/156.7	053	054	054	054	
	460-3-60	STD	CRHEATER116B00	13.9	12.8	43.6	047	047	047	047
			CRHEATER113B00	16.5	15.2	51.7	047	047	047	047
			CRHEATER115B00	33.0	30.3	103.4	050	050	050	050
			CRHEATER128B00	41.7	38.3	130.7	052	052	052	052
			CRHEATER129B00	50.0	45.9	156.7	052	052	052	052
		MED	CRHEATER116B00	13.9	12.8	43.6	047	047	047	047
			CRHEATER113B00	16.5	15.2	51.7	047	047	047	047
			CRHEATER115B00	33.0	30.3	103.4	050	050	050	050
			CRHEATER128B00	41.7	38.3	130.7	052	052	052	052
		HIGH	CRHEATER129B00	50.0	45.9	156.7	052	052	052	052
			CRHEATER116B00	13.9	12.8	43.6	047	047	047	047
			CRHEATER113B00	16.5	15.2	51.7	047	047	047	047
	CRHEATER115B00		33.0	30.3	103.4	050	050	050	050	
	CRHEATER128B00		41.7	38.3	130.7	052	052	052	052	
	575-3-60	STD	CRHEATER118A00	18.0	16.5	56.4	047	047	047	047
			CRHEATER119A00	36.0	33.1	112.8	050	050	050	050
			CRHEATER380A00	54.0	49.6	169.2	052	052	052	052
		MED	CRHEATER118A00	18.0	16.5	56.4	047	047	047	047
			CRHEATER119A00	36.0	33.1	112.8	050	050	050	050
			CRHEATER380A00	54.0	49.6	169.2	052	052	052	052
		HIGH	CRHEATER118A00	18.0	16.5	56.4	047	047	047	047
CRHEATER119A00			36.0	33.1	112.8	050	050	050	050	
CRHEATER380A00			54.0	49.6	169.2	052	052	052	052	

LEGEND

- APP PWR** — 208/230v/460v/575v
- C.O.** — Convenience Outlet
- IFM** — Indoor Fan Motor
- NOM PWR** — 240v/480v/600v
- P.E.** — Power Exhaust
- PwrD fr/unit** — Powered From Unit
- PWRD C.O.** — Powered Convenience Outlet

Electrical data (cont)

548J*14 ELECTRIC HEAT — TWO-SPEED INDOOR FAN MOTOR

UNIT	NOM. V-Ph-Hz	IFM TYPE	ELECTRIC HEATER PART NUMBER	NOM. PWR (kW)	APP PWR (kW)	APP OUTPUT (MBH)	SINGLE POINT OR JUNCTION KIT PART NUMBER			
							NO C.O. or Unpowered C.O.		w/PWRD C.O.	
							NO P.E.	w/ P.E. (pwrdr fr unit)	NO P.E.	w/ P.E. (pwrdr fr unit)
548J*14D	208/230-3-60	STD	CRHEATER291A00	16.5	12.4/15.2	42.3/51.7	051	051	051	051
			CRHEATER370A00	26.5	19.9/24.3	67.9/83.0	053	053	053	053
			CRHEATER294A00	33.5	25.2/30.8	85.9/105.0	053	053	053	053
			CRHEATER367A00	43.5	32.7/40.0	111.5/136.3	054	054	054	054
			CRHEATER368A00	50.0	37.6/45.9	128.1/156.7	054	054	054	054
		MED	CRHEATER291A00	16.5	12.4/15.2	42.3/51.7	051	051	051	051
			CRHEATER370A00	26.5	19.9/24.3	67.9/83.0	053	053	053	053
			CRHEATER294A00	33.5	25.2/30.8	85.9/105.0	053	053	053	053
			CRHEATER367A00	43.5	32.7/40.0	111.5/136.3	054	054	054	054
			CRHEATER368A00	50.0	37.6/45.9	128.1/156.7	054	054	054	054
		HIGH	CRHEATER291A00	16.5	12.4/15.2	42.3/51.7	051	051	051	051
			CRHEATER370A00	26.5	19.9/24.3	67.9/83.0	053	053	053	053
			CRHEATER294A00	33.5	25.2/30.8	85.9/105.0	053	053	053	053
			CRHEATER367A00	43.5	32.7/40.0	111.5/136.3	054	054	054	054
			CRHEATER368A00	50.0	37.6/45.9	128.1/156.7	054	054	054	054
	460-3-60	STD	CRHEATER292A00	16.5	15.2	51.7	047	047	047	047
			CRHEATER377A00	26.5	24.3	83.0	050	050	050	050
			CRHEATER295A00	33.5	30.8	105.0	050	050	050	050
			CRHEATER374A00	43.5	40.0	136.3	052	052	052	052
			CRHEATER375A00	50.0	45.9	156.7	052	052	052	052
		MED	CRHEATER292A00	16.5	15.2	51.7	047	047	047	047
			CRHEATER377A00	26.5	24.3	83.0	050	050	050	050
			CRHEATER295A00	33.5	30.8	105.0	050	050	050	050
			CRHEATER374A00	43.5	40.0	136.3	052	052	052	052
		HIGH	CRHEATER375A00	50.0	45.9	156.7	052	052	052	052
			CRHEATER292A00	16.5	15.2	51.7	047	050	050	050
			CRHEATER377A00	26.5	24.3	83.0	050	050	050	050
			CRHEATER295A00	33.5	30.8	105.0	050	050	050	050
			CRHEATER374A00	43.5	40.0	136.3	052	052	052	052
			CRHEATER375A00	50.0	45.9	156.7	052	052	052	052
	575-3-60	STD	CRHEATER293A00	16.5	15.2	51.7	047	047	047	047
			CRHEATER384A00	26.5	24.3	83.0	047	050	047	050
			CRHEATER296A00	33.5	30.8	105.0	050	050	050	050
			CRHEATER381A00	43.5	40.0	136.3	052	052	052	052
			CRHEATER382A00	50.0	45.9	156.7	052	052	052	052
		MED	CRHEATER293A00	16.5	15.2	51.7	047	047	047	047
CRHEATER384A00			26.5	24.3	83.0	047	050	047	050	
CRHEATER296A00			33.5	30.8	105.0	050	050	050	050	
CRHEATER381A00			43.5	40.0	136.3	052	052	052	052	
CRHEATER382A00			50.0	45.9	156.7	052	052	052	052	
HIGH		CRHEATER293A00	16.5	15.2	51.7	047	047	047	047	
		CRHEATER384A00	26.5	24.3	83.0	050	050	050	050	
		CRHEATER296A00	33.5	30.8	105.0	050	050	050	050	
		CRHEATER381A00	43.5	40.0	136.3	052	052	052	052	
		CRHEATER382A00	50.0	45.9	156.7	052	052	052	052	

LEGEND

APP PWR	— 208/230v/460v/575v
C.O.	— Convenience Outlet
IFM	— Indoor Fan Motor
NOM PWR	— 240v/480v/600v
P.E.	— Power Exhaust
Pwrdr fr/unit	— Powered From Unit
PWRD C.O.	— Powered Convenience Outlet

Legend and Notes for tables on pages 70-94

LEGEND

BRKR	—	Circuit Breaker
C.O.	—	Convenience Outlet
DISC.	—	Disconnect
FLA	—	Full Load Amps
LRA	—	Locked Rotor Amps
MCA	—	Minimum Circuit Amps
P.E.	—	Power Exhaust
Pwr'd fr/ unit	—	Powered From Unit
PWRD C.O.	—	Powered Convenience Outlet
RLA	—	Rated Load Amps
UNPWR C.O.	—	Unpowered Convenience Outlet

NOTES:

- In compliance with NEC requirements for multimotor and combination load equipment (refer to NEC Articles 430 and 440), the over-current protective device for the unit shall be fuse or HACR breaker. Canadian units may be fuse or circuit breaker.
- For 208/230 v units, where one value is shown it is the same for either 208 or 230 volts.
- Unbalanced 3-Phase Supply Voltage**
Never operate a motor where a phase imbalance in supply voltage is greater than 2%. Use the following formula to determine the percentage of voltage imbalance.

$$\% \text{ Voltage Imbalance} = 100 \times \frac{\text{max voltage deviation from average voltage}}{\text{average voltage}}$$

Example: Supply voltage is 230-3-60



AB = 224 v
BC = 231 v
AC = 226 v

$$\text{Average Voltage} = \frac{(224 + 231 + 226)}{3} = \frac{681}{3} = 227$$

Determine maximum deviation from average voltage.

$$(AB) 227-224 = 3 \text{ v}$$

$$(BC) 231-227 = 4 \text{ v}$$

$$(AC) 227-226 = 1 \text{ v}$$

Maximum deviation is 4 v.

Determine percent of voltage imbalance.

$$\% \text{ Voltage Imbalance} = 100 \times \frac{4}{227} = 1.78\%$$

This amount of phase imbalance is satisfactory as it is below the maximum allowable 2%.

IMPORTANT: If the supply voltage phase imbalance is more than 2%, contact your local electric utility company immediately.

Electrical data (cont)

ELECTRIC DATA — SINGLE SPEED INDOOR FAN MOTOR

UNIT	V-Ph-Hz	VOLTAGE		COMP 1		COMP 2		OFM (ea)		IFM		
		RANGE		RLA	LRA	RLA	LRA	WATTS	FLA	TYPE	EFF at Full Load	FLA
		MIN	MAX									
548J*07	208-3-60	187	253	19.6	136	—	—	325	1.5	STD	0.8	5.2
						—	—	325	1.5	MED	0.9	8.4
						—	—	325	1.5	HIGH	0.9	8.4
	230-3-60	187	253	19.6	136	—	—	325	1.5	STD	0.8	5.2
						—	—	325	1.5	MED	0.9	8.3
						—	—	325	1.5	HIGH	0.9	8.3
	460-3-60	414	506	8.2	66	—	—	325	0.8	STD	0.8	2.6
						—	—	325	0.8	MED	0.9	4.2
						—	—	325	0.8	HIGH	0.9	4.2
	575-3-60	518	633	6.6	55	—	—	325	0.6	STD	0.7	1.6
						—	—	325	0.6	MED	0.8	2.8
						—	—	325	0.6	HIGH	0.8	2.8
548J*08	208-3-60	187	253	13.1	83	13.1	83	325	1.5	STD	0.8	5.2
								325	1.5	MED	0.8	7.5
								325	1.5	HIGH	0.8	7.5
	230-3-60	187	253	13.1	83	13.1	83	325	1.5	STD	0.8	5.2
								325	1.5	MED	0.8	7.5
								325	1.5	HIGH	0.8	7.5
	460-3-60	414	506	6.1	41	6.1	41	325	0.8	STD	0.8	2.6
								325	0.8	MED	0.8	3.4
								325	0.8	HIGH	0.8	3.4
	575-3-60	518	633	4.4	33	4.4	33	325	0.6	STD	0.7	1.6
								325	0.6	MED	0.8	2.8
								325	0.6	HIGH	0.8	2.8
548J*09	208-3-60	187	253	14.5	98	13.7	83	325	1.5	STD	0.8	5.2
								325	1.5	MED	0.8	7.5
								325	1.5	HIGH	0.8	7.5
	230-3-60	187	253	14.5	98	13.7	83	325	1.5	STD	0.8	5.2
								325	1.5	MED	0.8	7.5
								325	1.5	HIGH	0.8	7.5
	460-3-60	414	506	6.3	55	6.2	41	325	0.8	STD	0.8	2.6
								325	0.8	MED	0.8	3.4
								325	0.8	HIGH	0.8	3.4
	575-3-60	518	633	6.0	41	4.8	33	325	0.6	STD	0.7	1.6
								325	0.6	MED	0.8	2.8
								325	0.6	HIGH	0.8	2.8
548J*12	208-3-60	187	253	15.6	110	15.9	110	1070	6.2	STD	0.7	5.2
								1070	6.2	MED	0.9	10.6
								1070	6.2	HIGH	0.8	13.6
	230-3-60	187	253	15.6	110	15.9	110	1070	6.2	STD	0.7	5.2
								1070	6.2	MED	0.9	10.6
								1070	6.2	HIGH	0.8	12.7
	460-3-60	414	506	7.7	52	7.7	52	1070	3.1	STD	0.7	2.6
								1070	3.1	MED	0.9	5.3
								1070	3.1	HIGH	0.8	6.4
	575-3-60	518	633	5.8	39	5.7	39	1070	2.5	STD	0.8	2.0
								1070	2.5	MED	0.8	2.8
								1070	2.5	HIGH	0.8	5.6

ELECTRIC DATA — SINGLE SPEED INDOOR FAN MOTOR (cont)

UNIT	V-Ph-Hz	VOLTAGE		COMP 1		COMP 2		OFM (ea)		IFM		
		RANGE		RLA	LRA	RLA	LRA	WATTS	FLA	TYPE	EFF at Full Load	FLA
		MIN	MAX									
548J*14	208-3-60	187	253	22.4	149	22.4	149	280	1.5	STD	0.8	7.5
								280	1.5	MED	0.8	7.5
								280	1.5	HIGH	0.9	17.0
								280	1.5	HIGH-High Efficiency	0.9	17.1
	230-3-60	187	253	22.4	149	22.4	149	280	1.5	STD	0.8	7.5
								280	1.5	MED	0.8	7.5
								280	1.5	HIGH	0.9	15.0
								280	1.5	HIGH-High Efficiency	0.9	17.1
	460-3-60	414	506	10.6	75	10.6	75	280	0.8	STD	0.8	3.4
								280	0.8	MED	0.8	3.4
								280	0.8	HIGH	0.9	7.6
								280	0.8	HIGH-High Efficiency	0.9	8.6
	575-3-60	518	633	8.5	54	8.5	54	280	0.7	STD	0.8	2.8
								280	0.7	MED	0.8	2.8
								280	0.7	HIGH	0.9	6.1
								280	0.7	HIGH-High Efficiency	0.9	9.0

See Legend and Notes on page 69.

Electrical data (cont)

ELECTRIC DATA — TWO SPEED INDOOR FAN MOTOR

UNIT	V-Ph-Hz	VOLTAGE		COMP 1		COMP 2		OFM (ea)		IFM		
		RANGE		RLA	LRA	RLA	LRA	WATTS	FLA	TYPE	EFF at Full Load	FLA
		MIN	MAX									
548J*07	208-3-60	187	253	19.6	136	—	—	325	1.5	STD	0.8	7.1
						—	—	325	1.5	MED	0.9	8.6
						—	—	325	1.5	HIGH	0.8	10.8
	230-3-60	187	253	19.6	136	—	—	325	1.5	STD	0.8	6.8
						—	—	325	1.5	MED	0.9	7.8
						—	—	325	1.5	HIGH	0.8	9.8
	460-3-60	414	506	8.2	66	—	—	325	0.8	STD	0.8	3.4
						—	—	325	0.8	MED	0.9	3.8
						—	—	325	0.8	HIGH	0.8	4.9
	575-3-60	518	633	6.6	55	—	—	325	0.6	STD	0.8	3.5
						—	—	325	0.6	MED	0.8	4.5
						—	—	325	0.6	HIGH	0.8	4.5
548J*08	208-3-60	187	253	13.1	83	13.1	83	325	1.5	STD	0.8	5.8
								325	1.5	MED	0.9	8.6
								325	1.5	HIGH	0.9	8.6
	230-3-60	187	253	13.1	83	13.1	83	325	1.5	STD	0.8	5.6
								325	1.5	MED	0.9	7.8
								325	1.5	HIGH	0.9	7.8
	460-3-60	414	506	6.1	41	6.1	41	325	0.8	STD	0.8	2.9
								325	0.8	MED	0.9	3.8
								325	0.8	HIGH	0.9	3.8
	575-3-60	518	633	4.4	33	4.4	33	325	0.6	STD	0.8	2.8
								325	0.6	MED	0.8	4.5
								325	0.6	HIGH	0.8	4.5
548J*09	208-3-60	187	253	14.5	98	13.7	83	325	1.5	STD	0.8	5.8
								325	1.5	MED	0.9	8.6
								325	1.5	HIGH	0.9	8.6
	230-3-60	187	253	14.5	98	13.7	83	325	1.5	STD	0.8	5.6
								325	1.5	MED	0.9	7.8
								325	1.5	HIGH	0.9	7.8
	460-3-60	414	506	6.3	55	6.2	41	325	0.8	STD	0.8	2.9
								325	0.8	MED	0.9	3.8
								325	0.8	HIGH	0.9	3.8
	575-3-60	518	633	6.0	41	4.8	33	325	0.6	STD	0.8	2.8
								325	0.6	MED	0.8	4.5
								325	0.6	HIGH	0.8	4.5
548J*12	208-3-60	187	253	15.6	110	15.9	110	1070	6.2	STD	0.8	7.1
								1070	6.2	MED	0.8	10.8
								1070	6.2	HIGH	0.8	13.6
	230-3-60	187	253	15.6	110	15.9	110	1070	6.2	STD	0.8	6.8
								1070	6.2	MED	0.8	9.8
								1070	6.2	HIGH	0.8	12.7
	460-3-60	414	506	7.7	52	7.7	52	1070	3.1	STD	0.8	3.4
								1070	3.1	MED	0.8	4.9
								1070	3.1	HIGH	0.8	6.4
	575-3-60	518	633	5.8	39	5.7	39	1070	2.5	STD	0.8	3.5
								1070	2.5	MED	0.8	4.5
								1070	2.5	HIGH	0.8	6.2

ELECTRIC DATA — TWO SPEED INDOOR FAN MOTOR (cont)

UNIT	V-Ph-Hz	VOLTAGE		COMP 1		COMP 2		OFM (ea)		IFM		
		RANGE		RLA	LRA	RLA	LRA	WATTS	FLA	TYPE	EFF at Full Load	FLA
		MIN	MAX									
548J*14	208-3-60	187	253	22.4	149	22.4	149	280	1.5	STD	0.9	8.6
								280	1.5	MED	0.9	8.6
								280	1.5	HIGH	0.9	17.1
	230-3-60	187	253	22.4	149	22.4	149	280	1.5	STD	0.9	7.8
								280	1.5	MED	0.9	7.8
								280	1.5	HIGH	0.9	17.1
	460-3-60	414	506	10.6	75	10.6	75	280	0.8	STD	0.9	3.8
								280	0.8	MED	0.9	3.8
								280	0.8	HIGH	0.9	8.6
	575-3-60	518	633	8.5	54	8.5	54	280	0.7	STD	0.8	4.5
								280	0.7	MED	0.8	4.5
								280	0.7	HIGH	0.9	9.0

See Legend and Notes on page 69.

Electrical data (cont)

548J*07A — UNIT WIRE/FUSE OR HACR BREAKER SIZING DATA — SINGLE SPEED INDOOR FAN MOTOR

UNIT	NOM. V-Ph-Hz	IFM TYPE	ELEC. HEATER			NO C.O. or UNPWR C.O.							
			CRHEATER***A00	NOM (kW)	FLA	NO P.E.				w/ P.E. (pwrd fr/unit)			
						MCA	FUSE OR HACR BRKR	DISC. SIZE		MCA	FUSE OR HACR BRKR	DISC. SIZE	
								FLA	LRA			FLA	LRA
548J*07A	208/230-3-60	STD	NONE	—	—	32	50	30	159	34	50	32	161
			102A	4.9/6.5	13.6/15.6	49/51	60/60	46/48	173/175	51/53	60/60	48/50	175/177
			104B	7.9/10.5	21.9/25.3	59/63	60/70	55/59	181/184	61/65	70/70	58/62	183/186
			105A	12.0/16.0	33.4/38.5	73/80	80/80	69/75	192/198	75/82	80/90	71/77	194/200
			361A	15.8/21.0	43.8/50.5	86/95	90/100	81/88	203/210	88/97	90/100	83/91	205/212
			362A	19.9/26.5	55.2/63.8	101/111	110/125	94/104	214/223	103/113	110/125	96/106	216/225
		MED	NONE	—	—	35/35	50/50	34/34	212	37/37	50/50	36/36	214
			102A	4.9/6.5	13.6/15.6	52/54	60/60	50/52	226/228	54/56	60/60	52/54	228/230
			104B	7.9/10.5	21.9/25.3	62/66	70/70	59/63	234/237	64/68	70/80	61/65	236/239
			105A	12.0/16.0	33.4/38.5	77/83	80/90	72/78	245/251	79/85	80/90	75/80	247/253
			361A	15.8/21.0	43.8/50.5	90/98	90/100	84/92	256/263	92/100	100/100	86/94	258/265
			362A	19.9/26.5	55.2/63.8	104/115	110/125	97/107	267/276	106/116	110/125	100/109	269/278
		HIGH	NONE	—	—	35/35	50/50	34/34	212	37/37	50/50	36/36	214
			102A	4.9/6.5	13.6/15.6	52/54	60/60	50/52	226/228	54/56	60/60	52/54	228/230
			104B	7.9/10.5	21.9/25.3	62/66	70/70	59/63	234/237	64/68	70/80	61/65	236/239
			105A	12.0/16.0	33.4/38.5	77/83	80/90	72/78	245/251	79/85	80/90	75/80	247/253
			361A	15.8/21.0	43.8/50.5	90/98	90/100	84/92	256/263	92/100	100/100	86/94	258/265
			362A	19.9/26.5	55.2/63.8	104/115	110/125	97/107	267/276	106/116	110/125	100/109	269/278
	460-3-60	STD	NONE	—	—	14	20	13	77	15	20	14	78
			106A	6.0	7.2	23	25	22	84	24	30	23	85
			108A	11.5	13.8	31	35	29	91	32	35	30	92
			109A	14.0	16.8	35	35	33	94	36	40	34	95
			372A	23.0	27.7	49	50	45	105	50	50	46	106
			373A	25.5	30.7	52	60	49	108	53	60	50	109
		MED	NONE	—	—	16	20	15	104	17	20	16	105
			106A	6.0	7.2	25	30	23	111	26	30	25	112
			108A	11.5	13.8	33	35	31	118	34	35	32	119
109A			14.0	16.8	37	40	35	121	38	40	36	122	
372A			23.0	27.7	50	50	47	132	51	60	48	133	
373A			25.5	30.7	54	60	50	135	55	60	52	136	
HIGH		NONE	—	—	16	20	15	104	17	20	16	105	
		106A	6.0	7.2	25	30	23	111	26	30	25	112	
		108A	11.5	13.8	33	35	31	118	34	35	32	119	
		109A	14.0	16.8	37	40	35	121	38	40	36	122	
		372A	23.0	27.7	50	50	47	132	51	60	48	133	
		373A	25.5	30.7	54	60	50	135	55	60	52	136	
575-3-60	STD	NONE	—	—	11	15	10	64	13	15	12	66	
	MED	NONE	—	—	12	15	12	79	14	20	14	81	
	HIGH	NONE	—	—	12	15	12	79	14	20	14	81	

See Legend and Notes on page 69.

**548J*07A — UNIT WIRE/FUSE OR HACR BREAKER SIZING DATA — SINGLE SPEED INDOOR FAN MOTOR
(cont)**

UNIT	NOM. V-Ph-Hz	IFM TYPE	ELEC. HEATER			w/ PWRD C.O.							
			CRHEATER***A00	NOM (kW)	FLA	NO P.E.				w/ P.E. (pwrd fr/unit)			
						MCA	FUSE OR HACR BRKR	DISC. SIZE		MCA	FUSE OR HACR BRKR	DISC. SIZE	
								FLA	LRA			FLA	LRA
548J*07A	208/230-3-60	STD	NONE	—	—	36	50	36	164	38	50	38	166
			102A	4.9/6.5	13.6/15.6	53/56	60/60	51/54	178/180	55/58	60/60	54/56	180/182
			104B	7.9/10.5	21.9/25.3	64/68	70/80	61/65	186/189	66/70	70/80	63/67	188/191
			105A	12.0/16.0	33.4/38.5	78/85	80/90	74/80	197/203	80/86	80/90	76/82	199/205
			361A	15.8/21.0	43.8/50.5	91/100	100/100	86/94	208/215	93/101	100/110	88/96	210/217
			362A	19.9/26.5	55.2/63.8	105/116	110/125	99/109	219/228	107/118	110/125	101/111	221/230
		MED	NONE	—	—	40/40	50/50	39/39	217	42/41	60/60	42/42	219
			102A	4.9/6.5	13.6/15.6	57/59	60/60	55/57	231/233	59/61	60/70	57/59	233/235
			104B	7.9/10.5	21.9/25.3	67/71	80/80	65/68	239/242	69/73	80/80	67/71	241/244
			105A	12.0/16.0	33.4/38.5	81/88	90/90	78/84	250/256	83/90	90/90	80/86	252/258
			361A	15.8/21.0	43.8/50.5	94/103	100/110	90/97	261/268	96/105	100/110	92/100	263/270
			362A	19.9/26.5	55.2/63.8	109/119	110/125	103/113	272/281	111/121	125/125	105/115	274/283
		HIGH	NONE	—	—	40/40	50/50	39/39	217	42/41	60/60	42/42	219
			102A	4.9/6.5	13.6/15.6	57/59	60/60	55/57	231/233	59/61	60/70	57/59	233/235
			104B	7.9/10.5	21.9/25.3	67/71	80/80	65/68	239/242	69/73	80/80	67/71	241/244
			105A	12.0/16.0	33.4/38.5	81/88	90/90	78/84	250/256	83/90	90/90	80/86	252/258
			361A	15.8/21.0	43.8/50.5	94/103	100/110	90/97	261/268	96/105	100/110	92/100	263/270
			362A	19.9/26.5	55.2/63.8	109/119	110/125	103/113	272/281	111/121	125/125	105/115	274/283
	460-3-60	STD	NONE	—	—	16	20	16	79	17	25	17	80
			106A	6.0	7.2	25	30	24	86	26	30	25	87
			108A	11.5	13.8	34	35	32	93	35	35	33	94
			109A	14.0	16.8	37	40	35	96	38	40	36	97
			372A	23.0	27.7	51	60	48	107	52	60	49	108
			373A	25.5	30.7	55	60	51	110	56	60	52	111
		MED	NONE	—	—	18	25	18	106	19	25	19	107
			106A	6.0	7.2	27	30	26	113	28	30	27	114
			108A	11.5	13.8	35	35	34	120	36	40	35	121
			109A	14.0	16.8	39	40	37	123	40	40	38	124
			372A	23.0	27.7	53	60	50	134	54	60	51	135
			373A	25.5	30.7	56	60	53	137	57	60	54	138
		HIGH	NONE	—	—	18	25	18	106	19	25	19	107
			106A	6.0	7.2	27	30	26	113	28	30	27	114
			108A	11.5	13.8	35	35	34	120	36	40	35	121
			109A	14.0	16.8	39	40	37	123	40	40	38	124
			372A	23.0	27.7	53	60	50	134	54	60	51	135
			373A	25.5	30.7	56	60	53	137	57	60	54	138
575-3-60	STD	NONE	—	—	13	15	12	66	15	20	14	68	
	MED	NONE	—	—	14	15	13	81	16	20	16	83	
	HIGH	NONE	—	—	14	15	13	81	16	20	16	83	

See Legend and Notes on page 69.

Electrical data (cont)

548J*08D — UNIT WIRE/FUSE OR HACR BREAKER SIZING DATA — SINGLE SPEED INDOOR FAN MOTOR

UNIT	NOM. V-Ph-Hz	IFM TYPE	ELEC. HEATER			NO C.O. or UNPWR C.O.							
			CRHEATER***A00	NOM (kW)	FLA	NO P.E.				w/ P.E. (pwrd fr/unit)			
						MCA	FUSE OR HACR BRKR	DISC. SIZE		MCA	FUSE OR HACR BRKR	DISC. SIZE	
								FLA	LRA			FLA	LRA
548J*08D	208/230-3-60	STD	NONE	—	—	38	50	40	193	42	50	44	197
			117A	7.8/10.4	21.7/25.0	65/69	70/70	65/68	215/218	69/73	70/80	69/73	219/222
			110A	12.0/16.0	33.4/38.5	80/86	80/90	78/84	226/232	84/90	90/90	82/88	230/236
			111A	18.6/24.8	51.7/59.7	103/113	110/125	99/108	245/253	107/117	110/125	103/113	249/257
			112A	24.0/32.0	66.7/77.0	122/134	125/150	116/128	260/270	125/138	125/150	121/132	264/274
			363A	31.8/42.4	88.4/102.0	149/166	150/175	141/157	281/295	152/169	175/175	146/161	285/299
		MED	NONE	—	—	40	50	42	230	44	50	47	234
			117A	7.8/10.4	21.7/25.0	68/72	70/80	67/71	252/255	71/75	80/80	72/75	256/259
			110A	12.0/16.0	33.4/38.5	82/89	90/90	81/86	263/269	86/92	90/100	85/91	267/273
			111A	18.6/24.8	51.7/59.7	105/115	110/125	102/111	282/290	109/119	110/125	106/115	286/294
			112A	24.0/32.0	66.7/77.0	124/137	125/150	119/131	297/307	128/140	150/150	123/135	301/311
			363A	31.8/42.4	88.4/102.0	151/168	175/175	144/160	318/332	155/172	175/175	148/164	322/336
		HIGH	NONE	—	—	40	50	42	230	44	50	47	234
			117A	7.8/10.4	21.7/25.0	68/72	70/80	67/71	252/255	71/75	80/80	72/75	256/259
			110A	12.0/16.0	33.4/38.5	82/89	90/90	81/86	263/269	86/92	90/100	85/91	267/273
			111A	18.6/24.8	51.7/59.7	105/115	110/125	102/111	282/290	109/119	110/125	106/115	286/294
			112A	24.0/32.0	66.7/77.0	124/137	125/150	119/131	297/307	128/140	150/150	123/135	301/311
			363A	31.8/42.4	88.4/102.0	151/168	175/175	144/160	318/332	155/172	175/175	148/164	322/336
	460-3-60	STD	NONE	—	—	18	20	19	95	20	25	21	97
			116B	13.9	16.7	39	40	38	112	41	45	40	114
			113B	16.5	19.8	43	45	42	115	45	45	44	117
			114B	27.8	33.4	60	60	57	128	62	70	59	130
			115B	33.0	39.7	68	70	65	135	70	70	67	137
			128B	41.7	50.2	81	90	77	145	83	90	79	147
		MED	NONE	—	—	19	25	20	114	21	25	22	116
			116B	13.9	16.7	40	40	39	131	42	45	41	133
			113B	16.5	19.8	44	45	43	134	46	50	45	136
			114B	27.8	33.4	61	70	58	147	63	70	60	149
			115B	33.0	39.7	69	70	65	154	71	80	68	156
			128B	41.7	50.2	82	90	78	164	84	90	80	166
		HIGH	NONE	—	—	19	25	20	114	21	25	22	116
			116B	13.9	16.7	40	40	39	131	42	45	41	133
			113B	16.5	19.8	44	45	43	134	46	50	45	136
			114B	27.8	33.4	61	70	58	147	63	70	60	149
			115B	33.0	39.7	69	70	65	154	71	80	68	156
			128B	41.7	50.2	82	90	78	164	84	90	80	166
575-3-60	STD	NONE	—	—	13	15	13	77	17	20	18	81	
		118A	18.0	17.3	35	35	33	94	39	40	38	98	
		119A	36.0	34.6	56	60	53	112	60	60	58	116	
	MED	NONE	—	—	14	20	15	92	18	20	19	96	
		118A	18.0	17.3	36	40	35	109	40	40	39	113	
		119A	36.0	34.6	58	60	55	127	61	70	59	131	
	HIGH	NONE	—	—	14	20	15	92	18	20	19	96	
		118A	18.0	17.3	36	40	35	109	40	40	39	113	
		119A	36.0	34.6	58	60	55	127	61	70	59	131	

See Legend and Notes on page 69.

**548J*08D — UNIT WIRE/FUSE OR HACR BREAKER SIZING DATA — SINGLE SPEED INDOOR FAN MOTOR
(cont)**

UNIT	NOM. V-Ph-Hz	IFM TYPE	ELEC. HEATER			w/ PWRD C.O.							
			CRHEATER***A00	NOM (kW)	FLA	NO P.E.				w/ P.E. (pwrd fr/unit)			
						MCA	FUSE OR HACR BRKR	DISC. SIZE		MCA	FUSE OR HACR BRKR	DISC. SIZE	
								FLA	LRA			FLA	LRA
548*08D	208/230-3-60	STD	NONE	—	—	43	50	45	198	47	50	49	202
			117A	7.8/10.4	21.7/25.0	70/74	70/80	70/74	220/223	74/78	80/80	74/78	224/227
			110A	12.0/16.0	33.4/38.5	85/91	90/100	83/89	231/237	88/95	90/100	88/94	235/241
			111A	18.6/24.8	51.7/59.7	108/118	110/125	105/114	250/258	111/121	125/125	109/118	254/262
			112A	24.0/32.0	66.7/77.0	126/139	150/150	122/134	265/275	130/143	150/150	126/138	269/279
			363A	31.8/42.4	88.4/102.0	153/170	175/175	147/162	286/300	157/174	175/175	151/167	290/304
		MED	NONE	—	—	45	50	48	235	49	60	52	239
			117A	7.8/10.4	21.7/25.0	72/76	80/80	73/76	257/260	76/80	80/80	77/81	261/264
			110A	12.0/16.0	33.4/38.5	87/93	90/100	86/92	268/274	91/97	100/100	91/96	272/278
			111A	18.6/24.8	51.7/59.7	110/120	110/125	107/116	287/295	114/124	125/125	112/121	291/299
			112A	24.0/32.0	66.7/77.0	129/141	150/150	124/136	302/312	132/145	150/150	129/141	306/316
			363A	31.8/42.4	88.4/102.0	156/173	175/175	149/165	323/337	160/177	175/200	154/169	327/341
		HIGH	NONE	—	—	45	50	48	235	49	60	52	239
			117A	7.8/10.4	21.7/25.0	72/76	80/80	73/76	257/260	76/80	80/80	77/81	261/264
			110A	12.0/16.0	33.4/38.5	87/93	90/100	86/92	268/274	91/97	100/100	91/96	272/278
			111A	18.6/24.8	51.7/59.7	110/120	110/125	107/116	287/295	114/124	125/125	112/121	291/299
			112A	24.0/32.0	66.7/77.0	129/141	150/150	124/136	302/312	132/145	150/150	129/141	306/316
			363A	31.8/42.4	88.4/102.0	156/173	175/175	149/165	323/337	160/177	175/200	154/169	327/341
	460-3-60	STD	NONE	—	—	21	25	21	97	22	25	23	99
			116B	13.9	16.7	41	45	41	114	43	45	43	116
			113B	16.5	19.8	45	45	44	117	47	50	46	119
			114B	27.8	33.4	62	70	60	130	64	70	62	132
			115B	33.0	39.7	70	70	67	137	72	80	69	139
			128B	41.7	50.2	83	90	79	147	85	90	81	149
		MED	NONE	—	—	21	25	22	116	23	25	24	118
			116B	13.9	16.7	42	45	42	133	44	45	44	135
			113B	16.5	19.8	46	50	45	136	48	50	47	138
			114B	27.8	33.4	63	70	61	149	65	70	63	151
			115B	33.0	39.7	71	80	68	156	73	80	70	158
			128B	41.7	50.2	84	90	80	166	86	90	82	168
		HIGH	NONE	—	—	21	25	22	116	23	25	24	118
			116B	13.9	16.7	42	45	42	133	44	45	44	135
			113B	16.5	19.8	46	50	45	136	48	50	47	138
			114B	27.8	33.4	63	70	61	149	65	70	63	151
			115B	33.0	39.7	71	80	68	156	73	80	70	158
			128B	41.7	50.2	84	90	80	166	86	90	82	168
575-3-60	STD	NONE	—	—	15	20	15	79	19	20	20	83	
		118A	18.0	17.3	36	40	35	96	40	40	40	100	
		119A	36.0	34.6	58	60	55	114	62	70	59	118	
	MED	NONE	—	—	16	20	17	94	20	25	21	98	
		118A	18.0	17.3	38	40	37	111	41	45	41	115	
		119A	36.0	34.6	59	60	56	129	63	70	61	133	
	HIGH	NONE	—	—	16	20	17	94	20	25	21	98	
		118A	18.0	17.3	38	40	37	111	41	45	41	115	
		119A	36.0	34.6	59	60	56	129	63	70	61	133	

See Legend and Notes on page 69.

Electrical data (cont)

548J*09D — UNIT WIRE/FUSE OR HACR BREAKER SIZING DATA — SINGLE SPEED INDOOR FAN MOTOR

UNIT	NOM. V-Ph-Hz	IFM TYPE	ELEC. HEATER			NO C.O. or UNPWR C.O.							
			CRHEATER***A00	NOM (kW)	FLA	NO P.E.				w/ P.E. (pwr'd fr/unit)			
						MCA	FUSE OR HACR BRKR	DISC. SIZE		MCA	FUSE OR HACR BRKR	DISC. SIZE	
								FLA	LRA			FLA	LRA
548J*09D	208/230-3-60	STD	NONE	—	—	40	50	42	208	44	50	46	212
			117A	7.8/10.4	21.7/25.0	68/72	70/80	67/71	230/233	71/76	80/80	71/75	234/237
			110A	12.0/16.0	33.4/38.5	82/89	90/90	80/86	241/247	86/92	90/100	85/91	245/251
			111A	18.6/24.8	51.7/59.7	105/115	110/125	101/111	260/268	109/119	110/125	106/115	264/272
			112A	24.0/32.0	66.7/77.0	124/137	125/150	119/130	275/285	128/141	150/150	123/135	279/289
			363A	31.8/42.4	88.4/102.0	151/168	175/175	144/159	296/310	155/172	175/175	148/164	300/314
		MED	NONE	—	—	43	50	45	245	47	60	49	249
			117A	7.8/10.4	21.7/25.0	70/74	70/80	69/73	267/270	74/78	80/80	74/78	271/274
			110A	12.0/16.0	33.4/38.5	85/91	90/100	83/89	278/284	88/95	90/100	87/93	282/288
			111A	18.6/24.8	51.7/59.7	107/117	110/125	104/113	297/305	111/121	125/125	108/118	301/309
			112A	24.0/32.0	66.7/77.0	126/139	150/150	121/133	312/322	130/143	150/150	126/137	316/326
			363A	31.8/42.4	88.4/102.0	153/170	175/175	146/162	333/347	157/174	175/175	151/166	337/351
		HIGH	NONE	—	—	43	50	45	245	47	60	49	249
			117A	7.8/10.4	21.7/25.0	70/74	70/80	69/73	267/270	74/78	80/80	74/78	271/274
			110A	12.0/16.0	33.4/38.5	85/91	90/100	83/89	278/284	88/95	90/100	87/93	282/288
			111A	18.6/24.8	51.7/59.7	107/117	110/125	104/113	297/305	111/121	125/125	108/118	301/309
			112A	24.0/32.0	66.7/77.0	126/139	150/150	121/133	312/322	130/143	150/150	126/137	316/326
			363A	31.8/42.4	88.4/102.0	153/170	175/175	146/162	333/347	157/174	175/175	151/166	337/351
	460-3-60	STD	NONE	—	—	19	20	19	109	21	25	21	111
			116B	13.9	16.7	40	40	38	126	41	45	40	128
			113B	16.5	19.8	43	45	42	129	45	45	44	131
			114B	27.8	33.4	60	70	58	142	62	70	60	144
			115B	33.0	39.7	68	70	65	149	70	70	67	151
			128B	41.7	50.2	81	90	77	159	83	90	79	161
MED		NONE	—	—	20	25	20	128	21	25	22	130	
		116B	13.9	16.7	40	40	39	145	42	45	41	147	
		113B	16.5	19.8	44	45	43	148	46	50	45	150	
		114B	27.8	33.4	61	70	59	161	63	70	61	163	
		115B	33.0	39.7	69	70	66	168	71	80	68	170	
		128B	41.7	50.2	82	90	78	178	84	90	80	180	
HIGH		NONE	—	—	20	25	20	128	21	25	22	130	
		116B	13.9	16.7	40	40	39	145	42	45	41	147	
		113B	16.5	19.8	44	45	43	148	46	50	45	150	
		114B	27.8	33.4	61	70	59	161	63	70	61	163	
		115B	33.0	39.7	69	70	66	168	71	80	68	170	
		128B	41.7	50.2	82	90	78	178	84	90	80	180	
575-3-60	STD	NONE	—	—	16	20	16	85	19	25	20	89	
		118A	18.0	17.3	37	40	36	102	41	45	40	106	
		119A	36.0	34.6	59	60	55	120	63	70	60	124	
	MED	NONE	—	—	17	20	17	100	21	25	21	104	
		118A	18.0	17.3	38	40	37	117	42	45	41	121	
		119A	36.0	34.6	60	60	57	135	64	70	61	139	
	HIGH	NONE	—	—	17	20	17	100	21	25	21	104	
		118A	18.0	17.3	38	40	37	117	42	45	41	121	
		119A	36.0	34.6	60	60	57	135	64	70	61	139	

See Legend and Notes on page 69.

**548J*09D — UNIT WIRE/FUSE OR HACR BREAKER SIZING DATA — SINGLE SPEED INDOOR FAN MOTOR
(cont)**

UNIT	NOM. V-Ph-Hz	IFM TYPE	ELEC. HEATER			w/ PWRD C.O.							
			CRHEATER***A00	NOM (kW)	FLA	NO P.E.				w/ P.E. (pwrd fr/unit)			
						MCA	FUSE OR HACR BRKR	DISC. SIZE		MCA	FUSE OR HACR BRKR	DISC. SIZE	
								FLA	LRA			FLA	LRA
548J*09D	208/230-3-60	STD	NONE	—	—	45	50	47	213	49	60	52	217
			117A	7.8/10.4	21.7/25.0	72/77	80/80	72/76	235/238	76/80	80/80	77/81	239/242
			110A	12.0/16.0	33.4/38.5	87/93	90/100	86/92	246/252	91/97	100/100	90/96	250/256
			111A	18.6/24.8	51.7/59.7	110/120	110/125	107/116	265/273	114/124	125/125	111/120	269/277
			112A	24.0/32.0	66.7/77.0	129/142	150/150	124/136	280/290	132/145	150/150	128/140	284/294
			363A	31.8/42.4	88.4/102.0	156/173	175/175	149/165	301/315	160/177	175/200	153/169	305/319
		MED	NONE	—	—	48	60	50	250	51	60	54	254
			117A	7.8/10.4	21.7/25.0	75/79	80/80	75/79	272/275	79/83	80/90	79/83	276/279
			110A	12.0/16.0	33.4/38.5	89/96	90/100	88/94	283/289	93/100	100/100	93/99	287/293
			111A	18.6/24.8	51.7/59.7	112/122	125/125	109/119	302/310	116/126	125/150	114/123	306/314
			112A	24.0/32.0	66.7/77.0	131/144	150/150	127/139	317/327	135/148	150/150	131/143	321/331
			363A	31.8/42.4	88.4/102.0	158/175	175/175	152/167	338/352	162/179	175/200	156/172	342/356
		HIGH	NONE	—	—	48	60	50	250	51	60	54	254
			117A	7.8/10.4	21.7/25.0	75/79	80/80	75/79	272/275	79/83	80/90	79/83	276/279
			110A	12.0/16.0	33.4/38.5	89/96	90/100	88/94	283/289	93/100	100/100	93/99	287/293
			111A	18.6/24.8	51.7/59.7	112/122	125/125	109/119	302/310	116/126	125/150	114/123	306/314
			112A	24.0/32.0	66.7/77.0	131/144	150/150	127/139	317/327	135/148	150/150	131/143	321/331
			363A	31.8/42.4	88.4/102.0	158/175	175/175	152/167	338/352	162/179	175/200	156/172	342/356
	460-3-60	STD	NONE	—	—	21	25	22	111	23	25	24	113
			116B	13.9	16.7	42	45	41	128	44	45	43	130
			113B	16.5	19.8	46	50	45	131	47	50	47	133
			114B	27.8	33.4	63	70	60	144	64	70	62	146
			115B	33.0	39.7	71	80	67	151	72	80	69	153
			128B	41.7	50.2	84	90	79	161	85	90	82	163
		MED	NONE	—	—	22	25	23	130	24	25	25	132
			116B	13.9	16.7	43	45	42	147	44	45	44	149
			113B	16.5	19.8	46	50	45	150	48	50	47	152
			114B	27.8	33.4	63	70	61	163	65	70	63	165
			115B	33.0	39.7	71	80	68	170	73	80	70	172
			128B	41.7	50.2	84	90	80	180	86	90	82	182
		HIGH	NONE	—	—	22	25	23	130	24	25	25	132
			116B	13.9	16.7	43	45	42	147	44	45	44	149
			113B	16.5	19.8	46	50	45	150	48	50	47	152
			114B	27.8	33.4	63	70	61	163	65	70	63	165
			115B	33.0	39.7	71	80	68	170	73	80	70	172
			128B	41.7	50.2	84	90	80	180	86	90	82	182
575-3-60	STD	NONE	—	—	17	20	18	87	21	25	22	91	
		118A	18.0	17.3	39	40	37	104	43	45	42	108	
		119A	36.0	34.6	61	70	57	122	64	70	62	126	
	MED	NONE	—	—	18	20	19	102	22	25	23	106	
		118A	18.0	17.3	40	40	39	119	44	45	43	123	
		119A	36.0	34.6	62	70	59	137	66	70	63	141	
	HIGH	NONE	—	—	18	20	19	102	22	25	23	106	
		118A	18.0	17.3	40	40	39	119	44	45	43	123	
		119A	36.0	34.6	62	70	59	137	66	70	63	141	

See Legend and Notes on page 69.

Electrical data (cont)

548J*12D — UNIT WIRE/FUSE OR HACR BREAKER SIZING DATA — SINGLE SPEED INDOOR FAN MOTOR

UNIT	NOM. V-Ph-Hz	IFM TYPE	ELEC. HEATER			NO C.O. or UNPWR C.O.							
			CRHEATER***A00	NOM (kW)	FLA	NO P.E.				w/ P.E. (pwrd fr/unit)			
						MCA	FUSE OR HACR BRKR	DISC. SIZE		MCA	FUSE OR HACR BRKR	DISC. SIZE	
								FLA	LRA			FLA	LRA
548J*12D	208/230-3-60	STD	NONE	—	—	47	60	49	282	51	60	54	286
			117A	7.8/10.4	21.7/25.0	74/79	80/80	74/78	304/307	78/82	80/90	79/82	308/311
			110A	12.0/16.0	33.4/38.5	89/95	90/100	88/94	315/321	93/99	100/100	92/98	319/325
			112A	24.0/32.0	66.7/77.0	131/144	150/150	126/138	349/359	135/147	150/150	130/142	353/363
			363A	31.8/42.4	88.4/102.0	158/175	175/175	151/167	370/384	162/179	175/200	155/171	374/388
			364A	37.6/50.0	104.2/120.3	178/168	200/175	169/188	386/402	181/171	200/175	174/192	390/406
		MED	NONE	—	—	53	60	56	338	57	70	60	342
			117A	7.8/10.4	21.7/25.0	80/84	80/90	81/84	360/363	84/88	90/90	85/89	364/367
			110A	12.0/16.0	33.4/38.5	94/101	100/110	94/100	371/377	98/105	100/110	98/104	375/381
			112A	24.0/32.0	66.7/77.0	136/149	150/150	132/144	405/415	140/153	150/175	137/148	409/419
			363A	31.8/42.4	88.4/102.0	163/180	175/200	157/173	426/440	167/184	175/200	162/177	430/444
			364A	37.6/50.0	104.2/120.3	183/173	200/200	175/194	442/458	187/177	200/200	180/198	446/462
		HIGH	NONE	—	—	56/55	60/60	59/58	340	60/59	70/70	63/62	344
			117A	7.8/10.4	21.7/25.0	83/86	90/90	84/87	362/365	87/90	90/90	88/91	366/369
			110A	12.0/16.0	33.4/38.5	97/103	100/110	97/102	373/379	101/107	110/110	102/107	377/383
			112A	24.0/32.0	66.7/77.0	139/151	150/175	136/147	407/417	143/155	150/175	140/151	411/421
			363A	31.8/42.4	88.4/102.0	166/182	175/200	161/175	428/442	170/186	175/200	165/180	432/446
			364A	37.6/50.0	104.2/120.3	186/175	200/200	179/196	444/460	190/179	200/200	183/201	448/464
	460-3-60	STD	NONE	—	—	23	30	24	135	25	30	26	137
			116B	13.9	16.7	44	45	43	152	46	50	46	154
			113B	16.5	19.8	48	50	47	155	50	50	49	157
			115B	33.0	39.7	73	80	70	175	75	80	72	177
			128B	41.7	50.2	86	90	82	185	88	90	84	187
			129B	50.0	60.1	84	90	93	195	85	90	95	197
		MED	NONE	—	—	26	30	27	163	28	30	29	165
			116B	13.9	16.7	47	50	47	180	49	50	49	182
			113B	16.5	19.8	51	60	50	183	53	60	52	185
			115B	33.0	39.7	76	80	73	203	78	80	75	205
			128B	41.7	50.2	89	90	85	213	91	100	87	215
			129B	50.0	60.1	86	90	96	223	88	90	99	225
		HIGH	NONE	—	—	27	30	29	164	29	35	31	166
			116B	13.9	16.7	48	50	48	181	50	50	50	183
			113B	16.5	19.8	52	60	51	184	54	60	53	186
			115B	33.0	39.7	77	80	74	204	79	80	76	206
			128B	41.7	50.2	90	90	86	214	92	100	88	216
			129B	50.0	60.1	87	90	98	224	89	100	100	226
	575-3-60	STD	NONE	—	—	18	20	18	105	22	25	23	109
			118A	18.0	17.3	40	40	38	122	43	45	43	126
			119A	36.0	34.6	61	70	58	140	65	70	63	144
			380A	54.0	52.0	70	80	78	157	74	80	83	161
		MED	NONE	—	—	19	20	19	116	23	25	24	120
			118A	18.0	17.3	40	40	39	133	44	45	44	137
119A			36.0	34.6	62	70	59	151	66	70	63	155	
380A			54.0	52.0	71	80	79	168	75	80	83	172	
HIGH		NONE	—	—	22	25	23	130	25	30	27	134	
		118A	18.0	17.3	43	45	42	147	47	50	47	151	
		119A	36.0	34.6	65	70	62	165	69	70	67	169	
		380A	54.0	52.0	74	80	82	182	77	80	87	186	

See Legend and Notes on page 69.

**548J*12D — UNIT WIRE/FUSE OR HACR BREAKER SIZING DATA — SINGLE SPEED INDOOR FAN MOTOR
(cont)**

UNIT	NOM. V-Ph-Hz	IFM TYPE	ELEC. HEATER			w/ PWRD C.O.							
			CRHEATER***A00	NOM (kW)	FLA	NO P.E.				w/ P.E. (pwrd fr/unit)			
						MCA	FUSE OR HACR BRKR	DISC. SIZE		MCA	FUSE OR HACR BRKR	DISC. SIZE	
								FLA	LRA			FLA	LRA
548J*12D	208/230-3-60	STD	NONE	—	—	52	60	55	287	56	60	59	291
			117A	7.8/10.4	21.7/25.0	79/83	80/90	80/84	309/312	83/87	90/90	84/88	313/316
			110A	12.0/16.0	33.4/38.5	94/100	100/100	93/99	320/326	98/104	100/110	98/104	324/330
			112A	24.0/32.0	66.7/77.0	136/148	150/150	132/143	354/364	139/152	150/175	136/148	358/368
			363A	31.8/42.4	88.4/102.0	163/180	175/200	157/172	375/389	166/183	175/200	161/177	379/393
			364A	37.6/50.0	104.2/120.3	182/172	200/200	175/193	391/407	186/176	200/200	179/198	395/411
		MED	NONE	—	—	58	70	61	343	61	70	65	347
			117A	7.8/10.4	21.7/25.0	85/89	90/90	86/90	365/368	88/93	90/100	90/94	369/372
			110A	12.0/16.0	33.4/38.5	99/106	100/110	99/105	376/382	103/109	110/110	104/110	380/386
			112A	24.0/32.0	66.7/77.0	141/154	150/175	138/150	410/420	145/158	150/175	142/154	414/424
			363A	31.8/42.4	88.4/102.0	168/185	175/200	163/178	431/445	172/189	175/200	167/183	435/449
			364A	37.6/50.0	104.2/120.3	188/178	200/200	181/199	447/463	192/182	200/200	185/204	451/467
		HIGH	NONE	—	—	61/60	70/70	65/63	345	64/63	70/70	69/68	349
			117A	7.8/10.4	21.7/25.0	88/91	90/100	89/92	367/370	91/95	100/100	94/97	371/374
			110A	12.0/16.0	33.4/38.5	102/108	110/110	103/108	378/384	106/112	110/125	107/112	382/388
			112A	24.0/32.0	66.7/77.0	144/156	150/175	141/152	412/422	148/160	150/175	146/156	416/426
			363A	31.8/42.4	88.4/102.0	171/187	175/200	166/181	433/447	175/191	175/200	171/185	437/451
			364A	37.6/50.0	104.2/120.3	191/180	200/200	184/202	449/465	195/184	200/200	189/206	453/469
	460-3-60	STD	NONE	—	—	26	30	27	137	27	30	29	139
			116B	13.9	16.7	47	50	46	154	48	50	48	156
			113B	16.5	19.8	50	50	50	157	52	60	52	159
			115B	33.0	39.7	75	80	72	177	77	80	75	179
			128B	41.7	50.2	88	90	85	187	90	90	87	189
			129B	50.0	60.1	86	90	96	197	88	90	98	199
		MED	NONE	—	—	28	30	30	165	30	35	32	167
			116B	13.9	16.7	49	50	49	182	51	60	51	184
			113B	16.5	19.8	53	60	53	185	55	60	55	187
			115B	33.0	39.7	78	80	76	205	80	80	78	207
			128B	41.7	50.2	91	100	88	215	93	100	90	217
			129B	50.0	60.1	88	90	99	225	90	100	101	227
		HIGH	NONE	—	—	29	35	31	166	31	35	33	168
			116B	13.9	16.7	50	50	50	183	52	60	52	185
			113B	16.5	19.8	54	60	54	186	56	60	56	188
			115B	33.0	39.7	79	80	77	206	81	90	79	208
			128B	41.7	50.2	92	100	89	216	94	100	91	218
			129B	50.0	60.1	90	100	100	226	91	100	102	228
	575-3-60	STD	NONE	—	—	20	25	20	107	23	25	25	111
			118A	18.0	17.3	41	45	40	124	45	45	45	128
			119A	36.0	34.6	63	70	60	142	67	70	65	146
			380A	54.0	52.0	72	80	80	159	75	80	85	163
		MED	NONE	—	—	20	25	21	118	24	30	26	122
			118A	18.0	17.3	42	45	41	135	46	50	46	139
119A			36.0	34.6	64	70	61	153	67	70	65	157	
380A			54.0	52.0	72	80	81	170	76	80	85	174	
HIGH		NONE	—	—	23	25	24	132	27	30	29	136	
		118A	18.0	17.3	45	45	44	149	49	50	49	153	
		119A	36.0	34.6	66	70	64	167	70	70	69	171	
		380A	54.0	52.0	75	80	84	184	79	80	89	188	

See Legend and Notes on page 69.

Electrical data (cont)

548J*14D — UNIT WIRE/FUSE OR HACR BREAKER SIZING DATA — SINGLE SPEED INDOOR FAN MOTOR

UNIT	NOM. V-Ph-Hz	IFM TYPE	ELEC. HEATER			NO C.O. or UNPWR C.O.							
			CRHEATER***A00	NOM (kW)	FLA	NO P.E.				w/ P.E. (pwrd fr/unit)			
						MCA	FUSE OR HACR BRKR	DISC. SIZE		MCA	FUSE OR HACR BRKR	DISC. SIZE	
								FLA	LRA			FLA	LRA
548J*14D	208/230-3-60	STD	NONE	—	—	63	80	65	366	67	80	70	370
			291A	12.4/16.5	34.4/39.7	106/112	110/125	105/111	400/406	110/116	110/125	109/115	404/410
			370A	19.9/26.5	55.3/63.8	132/143	150/150	129/139	421/430	136/146	150/150	133/143	425/434
			294A	25.2/33.5	69.9/80.6	150/164	150/175	146/158	436/447	154/167	175/175	150/162	440/451
			367A	32.7/43.5	90.7/104.7	176/194	200/200	170/186	457/471	180/198	200/200	174/190	461/475
			368A	37.6/50.0	104.3/120.3	193/183	200/200	185/204	470/486	197/187	200/200	190/208	474/490
		MED	NONE	—	—	63	80	65	366	67	80	70	370
			291A	12.4/16.5	34.4/39.7	106/112	110/125	105/111	400/406	110/116	110/125	109/115	404/410
			370A	19.9/26.5	55.3/63.8	132/143	150/150	129/139	421/430	136/146	150/150	133/143	425/434
			294A	25.2/33.5	69.9/80.6	150/164	150/175	146/158	436/447	154/167	175/175	150/162	440/451
			367A	32.7/43.5	90.7/104.7	176/194	200/200	170/186	457/471	180/198	200/200	174/190	461/475
			368A	37.6/50.0	104.3/120.3	193/183	200/200	185/204	470/486	197/187	200/200	190/208	474/490
		HIGH	NONE	—	—	72/70	80/80	76/74	394	76/74	90/80	81/78	398
			291A	12.4/16.5	34.4/39.7	115/120	125/125	116/120	428/434	119/124	125/125	120/124	432/438
			370A	19.9/26.5	55.3/63.8	141/150	150/150	140/147	449/458	145/154	150/175	144/152	453/462
			294A	25.2/33.5	69.9/80.6	160/171	175/175	157/167	464/475	164/175	175/175	161/171	468/479
			367A	32.7/43.5	90.7/104.7	186/201	200/225	181/194	485/499	190/205	200/225	185/199	489/503
			368A	37.6/50.0	104.3/120.3	203/191	225/200	196/212	498/514	207/194	225/200	201/217	502/518
		HIGH-High Efficiency	NONE	—	—	72	80	76	402	76	90	81	406
			291A	12.4/16.5	34.4/39.7	115/122	125/125	116/122	436/442	119/126	125/150	120/126	440/446
			370A	19.9/26.5	55.3/63.8	142/152	150/175	140/150	457/466	145/156	150/175	144/154	461/470
			294A	25.2/33.5	69.9/80.6	160/173	175/175	157/169	472/483	164/177	175/200	161/173	476/487
			367A	32.7/43.5	90.7/104.7	186/203	200/225	181/197	493/507	190/207	200/225	185/201	497/511
			368A	37.6/50.0	104.3/120.3	203/193	225/200	196/215	506/522	207/197	225/225	201/219	510/526
	460-3-60	STD	NONE	—	—	30	40	31	184	32	40	33	186
			292A	16.5	19.9	55	60	54	204	57	60	56	206
			377A	26.5	31.9	70	70	68	216	72	80	70	218
			295A	33.5	40.3	80	90	77	224	82	90	79	226
			374A	43.5	52.3	95	100	91	236	97	100	93	238
			375A	50.0	60.2	90	100	100	244	92	100	102	246
		MED	NONE	—	—	30	40	31	184	32	40	33	186
			292A	16.5	19.9	55	60	54	204	57	60	56	206
			377A	26.5	31.9	70	70	68	216	72	80	70	218
			295A	33.5	40.3	80	90	77	224	82	90	79	226
			374A	43.5	52.3	95	100	91	236	97	100	93	238
			375A	50.0	60.2	90	100	100	244	92	100	102	246
		HIGH	NONE	—	—	34	40	36	198	36	45	38	200
			292A	16.5	19.9	59	60	59	218	61	70	61	220
			377A	26.5	31.9	74	80	73	230	76	80	75	232
			295A	33.5	40.3	85	90	82	238	86	90	84	240
			374A	43.5	52.3	100	100	96	250	101	110	98	252
			375A	50.0	60.2	95	100	105	258	96	100	107	260
		HIGH-High Efficiency	NONE	—	—	35	45	37	202	37	45	39	204
			292A	16.5	19.9	60	60	60	222	62	70	62	224
			377A	26.5	31.9	75	80	74	234	77	80	76	236
			295A	33.5	40.3	86	90	83	242	87	90	85	244
			374A	43.5	52.3	101	110	97	254	102	110	99	256
			375A	50.0	60.2	96	100	106	262	97	100	108	264

548J*14D — UNIT WIRE/FUSE OR HACR BREAKER SIZING DATA — SINGLE SPEED INDOOR FAN MOTOR

UNIT	NOM. V-Ph-Hz	IFM TYPE	ELEC. HEATER			NO C.O. or UNPWR C.O.							
			CRHEATER***A00	NOM (kW)	FLA	NO P.E.				w/ P.E. (pwrd fr/unit)			
						MCA	FUSE OR HACR BRKR	DISC. SIZE		MCA	FUSE OR HACR BRKR	DISC. SIZE	
FLA	LRA	FLA	LRA										
548J*14D (cont)	575-3-60	STD	NONE	—	—	24	30	25	136	28	30	30	140
			293A	16.5	15.9	44	45	43	152	48	50	48	156
			384A	26.5	25.5	56	60	55	162	60	60	59	166
			296A	33.5	32.2	65	70	62	168	69	70	67	172
			381A	43.5	41.9	77	80	73	178	81	90	78	182
			382A	50.0	48.1	73	80	81	184	76	80	85	188
		MED	NONE	—	—	24	30	25	136	28	30	30	140
			293A	16.5	15.9	44	45	43	152	48	50	48	156
			384A	26.5	25.5	56	60	55	162	60	60	59	166
			296A	33.5	32.2	65	70	62	168	69	70	67	172
			381A	43.5	41.9	77	80	73	178	81	90	78	182
			382A	50.0	48.1	73	80	81	184	76	80	85	188
		HIGH	NONE	—	—	28	30	29	139	32	35	33	143
			293A	16.5	15.9	48	50	47	155	51	60	52	159
			384A	26.5	25.5	60	60	58	165	63	70	63	169
			296A	33.5	32.2	68	70	66	171	72	80	70	175
			381A	43.5	41.9	80	80	77	181	84	90	82	185
			382A	50.0	48.1	76	80	84	187	80	90	89	191
		HIGH- High Efficiency	NONE	—	—	31	35	32	148	35	40	37	152
			293A	16.5	15.9	51	60	51	164	54	60	55	168
			384A	26.5	25.5	63	70	62	174	66	70	66	178
			296A	33.5	32.2	71	80	69	180	75	80	74	184
			381A	43.5	41.9	83	90	81	190	87	90	85	194
			382A	50.0	48.1	79	90	88	196	83	90	92	200

See Legend and Notes on page 69.

Electrical data (cont)

548J*14D — UNIT WIRE/FUSE OR HACR BREAKER SIZING DATA — SINGLE SPEED INDOOR FAN MOTOR (cont)

UNIT	NOM. V-Ph-Hz	IFM TYPE	ELEC. HEATER			w/ PWRD C.O.							
			CRHEATER***A00	NOM (kW)	FLA	NO P.E.				w/ P.E. (pwrd fr/unit)			
						MCA	FUSE OR HACR BRKR	DISC. SIZE		MCA	FUSE OR HACR BRKR	DISC. SIZE	
								FLA	LRA			FLA	LRA
548J*14D	208/230-3-60	STD	NONE	—	—	68	80	71	371	71	80	75	375
			291A	12.4/16.5	34.4/39.7	111/117	125/125	110/116	405/411	114/121	125/125	115/121	409/415
			370A	19.9/26.5	55.3/63.8	137/147	150/150	134/144	426/435	141/151	150/175	139/149	430/439
			294A	25.2/33.5	69.9/80.6	155/168	175/175	151/164	441/452	159/172	175/175	156/168	445/456
			367A	32.7/43.5	90.7/104.7	181/199	200/200	175/191	462/476	185/202	200/225	180/196	466/480
			368A	37.6/50.0	104.3/120.3	198/188	200/200	191/209	475/491	202/192	225/200	195/214	479/495
		MED	NONE	—	—	68	80	71	371	71	80	75	375
			291A	12.4/16.5	34.4/39.7	111/117	125/125	110/116	405/411	114/121	125/125	115/121	409/415
			370A	19.9/26.5	55.3/63.8	137/147	150/150	134/144	426/435	141/151	150/175	139/149	430/439
			294A	25.2/33.5	69.9/80.6	155/168	175/175	151/164	441/452	159/172	175/175	156/168	445/456
			367A	32.7/43.5	90.7/104.7	181/199	200/200	175/191	462/476	185/202	200/225	180/196	466/480
			368A	37.6/50.0	104.3/120.3	198/188	200/200	191/209	475/491	202/192	225/200	195/214	479/495
		HIGH	NONE	—	—	77/75	90/90	82/79	399	81/79	100/100	86/84	403
			291A	12.4/16.5	34.4/39.7	120/125	125/125	121/125	433/439	124/129	125/150	126/129	437/443
			370A	19.9/26.5	55.3/63.8	146/155	150/175	145/153	454/463	150/159	150/175	150/157	458/467
			294A	25.2/33.5	69.9/80.6	165/176	175/200	162/172	469/480	168/180	175/200	167/177	473/484
			367A	32.7/43.5	90.7/104.7	191/206	200/225	186/200	490/504	194/210	200/225	190/204	494/508
			368A	37.6/50.0	104.3/120.3	208/195	225/225	202/218	503/519	211/199	225/225	206/222	507/523
		HIGH-High Efficiency	NONE	—	—	77	90	82	407	81	100	86	411
			291A	12.4/16.5	34.4/39.7	120/127	125/150	121/128	441/447	124/131	125/150	126/132	445/451
			370A	19.9/26.5	55.3/63.8	146/157	150/175	145/155	462/471	150/161	150/175	150/160	466/475
	294A		25.2/33.5	69.9/80.6	165/178	175/200	162/175	477/488	168/182	175/200	167/179	481/492	
	367A		32.7/43.5	90.7/104.7	191/208	200/225	186/202	498/512	194/212	200/225	191/207	502/516	
	368A		37.6/50.0	104.3/120.3	208/198	225/225	202/220	511/527	211/201	225/225	206/225	515/531	
	460-3-60	STD	NONE	—	—	32	40	34	186	34	40	36	188
			292A	16.5	19.9	57	60	56	206	59	60	59	208
			377A	26.5	31.9	72	80	70	218	74	80	72	220
			295A	33.5	40.3	83	90	80	226	84	90	82	228
			374A	43.5	52.3	98	100	94	238	99	100	96	240
			375A	50.0	60.2	93	100	103	246	94	100	105	248
		MED	NONE	—	—	32	40	34	186	34	40	36	188
			292A	16.5	19.9	57	60	56	206	59	60	59	208
			377A	26.5	31.9	72	80	70	218	74	80	72	220
			295A	33.5	40.3	83	90	80	226	84	90	82	228
			374A	43.5	52.3	98	100	94	238	99	100	96	240
			375A	50.0	60.2	93	100	103	246	94	100	105	248
		HIGH	NONE	—	—	37	45	38	200	38	45	40	202
			292A	16.5	19.9	61	70	61	220	63	70	63	222
			377A	26.5	31.9	76	80	75	232	78	80	77	234
			295A	33.5	40.3	87	90	85	240	89	90	87	242
			374A	43.5	52.3	102	110	99	252	104	110	101	254
			375A	50.0	60.2	97	100	108	260	99	110	110	262
HIGH-High Efficiency		NONE	—	—	38	45	40	204	39	45	42	206	
		292A	16.5	19.9	62	70	62	224	64	70	65	226	
		377A	26.5	31.9	77	80	76	236	79	80	78	238	
	295A	33.5	40.3	88	90	86	244	90	90	88	246		
	374A	43.5	52.3	103	110	100	256	105	110	102	258		
	375A	50.0	60.2	98	100	109	264	100	110	111	266		

**548J*14D — UNIT WIRE/FUSE OR HACR BREAKER SIZING DATA — SINGLE SPEED INDOOR FAN MOTOR
(cont)**

UNIT	NOM. V-Ph-Hz	IFM TYPE	ELEC. HEATER			w/ PWRD C.O.							
			CRHEATER***A00	NOM (kW)	FLA	NO P.E.				w/ P.E. (pwrd fr/unit)			
						MCA	FUSE OR HACR BRKR	DISC. SIZE		MCA	FUSE OR HACR BRKR	DISC. SIZE	
FLA	LRA	FLA	LRA										
50TCQD14 (cont)	575-3-60	STD	NONE	—	—	26	30	27	138	30	35	32	142
			293A	16.5	15.9	46	50	45	154	50	50	50	158
			384A	26.5	25.5	58	60	56	164	62	70	61	168
			296A	33.5	32.2	66	70	64	170	70	70	69	174
			381A	43.5	41.9	79	80	75	180	82	90	80	184
			382A	50.0	48.1	74	80	82	186	78	80	87	190
		MED	NONE	—	—	26	30	27	138	30	35	32	142
			293A	16.5	15.9	46	50	45	154	50	50	50	158
			384A	26.5	25.5	58	60	56	164	62	70	61	168
			296A	33.5	32.2	66	70	64	170	70	70	69	174
			381A	43.5	41.9	79	80	75	180	82	90	80	184
			382A	50.0	48.1	74	80	82	186	78	80	87	190
		HIGH	NONE	—	—	29	35	31	141	33	40	35	145
			293A	16.5	15.9	49	50	49	157	53	60	54	161
			384A	26.5	25.5	61	70	60	167	65	70	65	171
			296A	33.5	32.2	70	70	68	173	74	80	72	177
			381A	43.5	41.9	82	90	79	183	86	90	83	187
			382A	50.0	48.1	78	80	86	189	81	90	91	193
		HIGH-High Efficiency	NONE	—	—	33	40	34	150	36	40	39	154
			293A	16.5	15.9	52	60	53	166	56	60	57	170
			384A	26.5	25.5	64	70	64	176	68	70	68	180
			296A	33.5	32.2	73	80	71	182	77	80	76	186
			381A	43.5	41.9	85	90	82	192	89	90	87	196
			382A	50.0	48.1	81	90	90	198	84	90	94	202

See Legend and Notes on page 69.

Electrical data (cont)

548J*07A — UNIT WIRE/FUSE OR HACR BREAKER SIZING DATA — TWO SPEED INDOOR FAN MOTOR

UNIT	NOM. V-Ph-Hz	IFM TYPE	ELEC. HEATER			NO C.O. or UNPWR C.O.							
			CRHEATER***A00	NOM (kW)	FLA	NO P.E.				w/ P.E. (pwrdr fr/unit)			
						MCA	FUSE OR HACR BRKR	DISC. SIZE		MCA	FUSE OR HACR BRKR	DISC. SIZE	
								FLA	LRA			FLA	LRA
548J*07A	208/230-3-60	STD	NONE	—	—	34/33	50/50	32/32	167	35/35	50/50	35/34	169
			102A	4.9/6.5	13.6/15.6	51/53	60/60	48/50	181/183	52/55	60/60	50/52	183/185
			104B	7.9/10.5	21.9/25.3	61/65	70/70	58/61	189/192	63/67	70/70	60/63	191/194
			105A	12.0/16.0	33.4/38.5	75/81	80/90	71/76	200/206	77/83	80/90	73/79	202/208
			361A	15.8/21.0	43.8/50.5	88/96	90/100	83/90	211/218	90/98	90/100	85/92	213/220
			362A	19.9/26.5	55.2/63.8	103/113	110/125	96/105	222/231	104/115	110/125	98/108	224/233
		MED	NONE	—	—	35/34	50/50	34/33	193	37/36	50/50	36/35	195
			102A	4.9/6.5	13.6/15.6	52/54	60/60	50/51	207/209	54/56	60/60	52/53	209/211
			104B	7.9/10.5	21.9/25.3	62/66	70/70	59/62	215/218	64/68	70/80	62/65	217/220
			105A	12.0/16.0	33.4/38.5	77/82	80/90	73/78	226/232	79/84	80/90	75/80	228/234
			361A	15.8/21.0	43.8/50.5	90/97	90/100	85/91	237/244	92/99	100/100	87/93	239/246
			362A	19.9/26.5	55.2/63.8	104/114	110/125	98/107	248/257	106/116	110/125	100/109	250/259
		HIGH	NONE	—	—	37/36	50/50	37/36	217	39/38	50/50	39/38	219
			102A	4.9/6.5	13.6/15.6	54/56	60/60	52/53	231/233	56/58	60/60	55/56	233/235
			104B	7.9/10.5	21.9/25.3	65/68	70/80	62/65	239/242	67/70	80/80	64/67	241/244
			105A	12.0/16.0	33.4/38.5	79/84	80/90	75/80	250/256	81/86	90/90	77/82	252/258
			361A	15.8/21.0	43.8/50.5	92/99	100/100	87/94	261/268	94/101	100/110	89/96	263/270
			362A	19.9/26.5	55.2/63.8	106/116	110/125	100/109	272/281	108/118	110/125	102/111	274/283
	460-3-60	STD	NONE	—	—	15	20	14	82	16	20	15	83
			106A	6.0	7.2	24	25	23	89	25	30	24	90
			108A	11.5	13.8	32	35	30	96	33	35	31	97
			109A	14.0	16.8	36	40	34	99	37	40	35	100
			372A	23.0	27.7	50	50	46	110	51	60	47	111
			373A	25.5	30.7	53	60	50	113	54	60	51	114
		MED	NONE	—	—	15	20	15	95	16	20	16	96
			106A	6.0	7.2	24	30	23	102	25	30	24	103
			108A	11.5	13.8	33	35	31	109	34	35	32	110
			109A	14.0	16.8	36	40	34	112	37	40	35	113
			372A	23.0	27.7	50	50	47	123	51	60	48	124
			373A	25.5	30.7	54	60	50	126	55	60	51	127
		HIGH	NONE	—	—	16	20	16	107	17	25	17	108
			106A	6.0	7.2	25	30	24	114	26	30	25	115
			108A	11.5	13.8	34	35	32	121	35	35	33	122
			109A	14.0	16.8	37	40	35	124	38	40	36	125
			372A	23.0	27.7	51	60	48	135	52	60	49	136
			373A	25.5	30.7	55	60	51	138	56	60	52	139
575-3-60	STD	NONE	—	—	13	15	12	70	15	20	14	72	
	MED	NONE	—	—	14	15	13	79	16	20	16	81	
	HIGH	NONE	—	—	14	15	13	79	16	20	16	81	

See Legend and Notes on page 69.

548J*07A — UNIT WIRE/FUSE OR HACR BREAKER SIZING DATA — TWO SPEED INDOOR FAN MOTOR (cont)

UNIT	NOM. V-Ph-Hz	IFM TYPE	ELEC. HEATER			w/ PWRD C.O.							
			CRHEATER***A00	NOM (kW)	FLA	NO P.E.				w/ P.E. (pwrd fr/unit)			
						MCA	FUSE OR HACR BRKR	DISC. SIZE		MCA	FUSE OR HACR BRKR	DISC. SIZE	
FLA	LRA	FLA	LRA										
548J*07A	208/230-3-60	STD	NONE	—	—	38/38	50/50	38/38	172	40/40	50/50	40/40	174
			102A	4.9/6.5	13.6/15.6	55/58	60/60	54/56	186/188	57/59	60/60	56/58	188/190
			104B	7.9/10.5	21.9/25.3	66/70	70/80	63/67	194/197	68/72	80/80	65/69	196/199
			105A	12.0/16.0	33.4/38.5	80/86	80/90	76/82	205/211	82/88	90/90	79/84	207/213
			361A	15.8/21.0	43.8/50.5	93/101	100/110	88/96	216/223	95/103	100/110	91/98	218/225
			362A	19.9/26.5	55.2/63.8	107/118	110/125	101/111	227/236	109/120	110/125	104/113	229/238
		MED	NONE	—	—	40/39	50/50	40/39	198	42/41	60/60	42/41	200
			102A	4.9/6.5	13.6/15.6	57/59	60/60	55/57	212/214	59/60	60/70	58/59	214/216
			104B	7.9/10.5	21.9/25.3	67/71	80/80	65/68	220/223	69/73	80/80	67/70	222/225
			105A	12.0/16.0	33.4/38.5	82/87	90/90	78/83	231/237	84/89	90/90	80/85	233/239
			361A	15.8/21.0	43.8/50.5	95/102	100/110	90/97	242/249	97/104	100/110	92/99	244/251
			362A	19.9/26.5	55.2/63.8	109/119	110/125	103/112	253/262	111/121	125/125	105/114	255/264
		HIGH	NONE	—	—	42/41	60/60	42/41	222	44/43	60/60	44/43	224
			102A	4.9/6.5	13.6/15.6	59/61	70/70	58/59	236/238	61/62	70/70	60/61	238/240
			104B	7.9/10.5	21.9/25.3	69/73	80/80	67/70	244/247	71/75	80/80	70/72	246/249
			105A	12.0/16.0	33.4/38.5	84/89	90/90	81/85	255/261	86/91	90/100	83/88	257/263
			361A	15.8/21.0	43.8/50.5	97/104	100/110	93/99	266/273	99/106	100/110	95/101	268/275
			362A	19.9/26.5	55.2/63.8	111/121	125/125	106/114	277/286	113/123	125/125	108/117	279/288
	460-3-60	STD	NONE	—	—	17	20	17	84	18	25	18	85
			106A	6.0	7.2	26	30	25	91	27	30	26	92
			108A	11.5	13.8	34	35	33	98	35	35	34	99
			109A	14.0	16.8	38	40	36	101	39	40	37	102
			372A	23.0	27.7	52	60	49	112	53	60	50	113
			373A	25.5	30.7	55	60	52	115	56	60	53	116
		MED	NONE	—	—	18	25	17	97	19	25	18	98
			106A	6.0	7.2	27	30	26	104	28	30	27	105
			108A	11.5	13.8	35	35	33	111	36	40	34	112
			109A	14.0	16.8	39	40	37	114	40	40	38	115
			372A	23.0	27.7	52	60	49	125	53	60	50	126
			373A	25.5	30.7	56	60	53	128	57	60	54	129
		HIGH	NONE	—	—	19	25	19	109	20	25	20	110
			106A	6.0	7.2	28	30	27	116	29	30	28	117
			108A	11.5	13.8	36	40	34	123	37	40	36	124
			109A	14.0	16.8	40	40	38	126	41	45	39	127
			372A	23.0	27.7	53	60	50	137	54	60	52	138
			373A	25.5	30.7	57	60	54	140	58	60	55	141
575-3-60	STD	NONE	—	—	15	20	14	72	16	20	16	74	
	MED	NONE	—	—	16	20	15	81	17	20	18	83	
	HIGH	NONE	—	—	16	20	15	81	17	20	18	83	

See Legend and Notes on page 69.

Electrical data (cont)

548J*08D — UNIT WIRE/FUSE OR HACR BREAKER SIZING DATA — TWO SPEED INDOOR FAN MOTOR

UNIT	NOM. V-Ph-Hz	IFM TYPE	ELEC. HEATER			NO C.O. or UNPWR C.O.							
			CRHEATER***A00	NOM (kW)	FLA	NO P.E.				w/ P.E. (pwrd fr/unit)			
						MCA	FUSE OR HACR BRKR	DISC. SIZE		MCA	FUSE OR HACR BRKR	DISC. SIZE	
								FLA	LRA			FLA	LRA
548J*08D	208/230-3-60	STD	NONE	—	—	39/39	50/50	40/40	197	43/42	50/50	45/44	201
			117A	7.8/10.4	21.7/25.0	66/70	70/70	65/69	219/222	70/74	70/80	70/73	223/226
			110A	12.0/16.0	33.4/38.5	80/87	90/90	79/84	230/236	84/90	90/90	83/89	234/240
			111A	18.6/24.8	51.7/59.7	103/113	110/125	100/109	249/257	107/117	110/125	104/113	253/261
			112A	24.0/32.0	66.7/77.0	122/135	125/150	117/129	264/274	126/139	150/150	121/133	268/278
		363A	31.8/42.4	88.4/102.0	149/166	150/175	142/157	285/299	153/170	175/175	146/162	289/303	
		MED	NONE	—	—	42/41	50/50	43/43	227	45/45	50/50	48/47	231
			117A	7.8/10.4	21.7/25.0	69/72	70/80	68/71	249/252	72/76	80/80	73/76	253/256
			110A	12.0/16.0	33.4/38.5	83/89	90/90	82/87	260/266	87/93	90/100	86/91	264/270
			111A	18.6/24.8	51.7/59.7	106/115	110/125	103/111	279/287	110/119	110/125	107/116	283/291
			112A	24.0/32.0	66.7/77.0	125/137	125/150	120/131	294/304	129/141	150/150	125/135	298/308
		363A	31.8/42.4	88.4/102.0	152/168	175/175	145/160	315/329	156/172	175/175	150/164	319/333	
		HIGH	NONE	—	—	42/41	50/50	43/43	227	45/45	50/50	48/47	231
			117A	7.8/10.4	21.7/25.0	69/72	70/80	68/71	249/252	72/76	80/80	73/76	253/256
			110A	12.0/16.0	33.4/38.5	83/89	90/90	82/87	260/266	87/93	90/100	86/91	264/270
			111A	18.6/24.8	51.7/59.7	106/115	110/125	103/111	279/287	110/119	110/125	107/116	283/291
			112A	24.0/32.0	66.7/77.0	125/137	125/150	120/131	294/304	129/141	150/150	125/135	298/308
		363A	31.8/42.4	88.4/102.0	152/168	175/175	145/160	315/329	156/172	175/175	150/164	319/333	
	460-3-60	STD	NONE	—	—	19	20	19	97	20	25	21	99
			116B	13.9	16.7	40	40	38	114	41	45	40	116
			113B	16.5	19.8	43	45	42	117	45	45	44	119
			114B	27.8	33.4	60	60	58	130	62	70	60	132
			115B	33.0	39.7	68	70	65	137	70	70	67	139
		128B	41.7	50.2	81	90	77	147	83	90	79	149	
		MED	NONE	—	—	20	25	20	113	21	25	22	115
			116B	13.9	16.7	40	40	39	130	42	45	42	132
			113B	16.5	19.8	44	45	43	133	46	50	45	135
			114B	27.8	33.4	61	70	59	146	63	70	61	148
			115B	33.0	39.7	69	70	66	153	71	80	68	155
		128B	41.7	50.2	82	90	78	163	84	90	80	165	
		HIGH	NONE	—	—	20	25	20	113	21	25	22	115
			116B	13.9	16.7	40	40	39	130	42	45	42	132
			113B	16.5	19.8	44	45	43	133	46	50	45	135
			114B	27.8	33.4	61	70	59	146	63	70	61	148
			115B	33.0	39.7	69	70	66	153	71	80	68	155
		128B	41.7	50.2	82	90	78	163	84	90	80	165	
	575-3-60	STD	NONE	—	—	14	20	15	79	18	20	19	83
			118A	18.0	17.3	36	40	35	96	40	40	39	100
			119A	36.0	34.6	58	60	55	114	61	70	59	118
		MED	NONE	—	—	16	20	17	92	20	25	21	96
			118A	18.0	17.3	38	40	37	109	42	45	41	113
			119A	36.0	34.6	59	60	56	127	63	70	61	131
HIGH		NONE	—	—	16	20	17	92	20	25	21	96	
		118A	18.0	17.3	38	40	37	109	42	45	41	113	
		119A	36.0	34.6	59	60	56	127	63	70	61	131	

See Legend and Notes on page 69.

548J*08D — UNIT WIRE/FUSE OR HACR BREAKER SIZING DATA — TWO SPEED INDOOR FAN MOTOR (cont)

UNIT	NOM. V-Ph-Hz	IFM TYPE	ELEC. HEATER			w/ PWRD C.O.							
			CRHEATER***A00	NOM (kW)	FLA	NO P.E.				w/ P.E. (pwrd fr/unit)			
						MCA	FUSE OR HACR BRKR	DISC. SIZE		MCA	FUSE OR HACR BRKR	DISC. SIZE	
FLA	LRA	FLA	LRA										
548J*08D	208/230-3-60	STD	NONE	—	—	44/43	50/50	46/46	202	47/47	60/50	50/50	206
			117A	7.8/10.4	21.7/25.0	71/75	80/80	71/74	224/227	74/78	80/80	75/79	228/231
			110A	12.0/16.0	33.4/38.5	85/91	90/100	84/90	235/241	89/95	90/100	89/94	239/245
			111A	18.6/24.8	51.7/59.7	108/118	110/125	105/114	254/262	112/122	125/125	110/119	258/266
			112A	24.0/32.0	66.7/77.0	127/140	150/150	122/134	269/279	131/143	150/150	127/138	273/283
			363A	31.8/42.4	88.4/102.0	154/171	175/175	147/163	290/304	158/175	175/175	152/167	294/308
		MED	NONE	—	—	46/46	50/50	49/48	232	50/49	60/60	53/52	236
			117A	7.8/10.4	21.7/25.0	73/77	80/80	74/77	254/257	77/81	80/90	78/81	258/261
			110A	12.0/16.0	33.4/38.5	88/94	90/100	87/92	265/271	92/97	100/100	92/97	269/275
			111A	18.6/24.8	51.7/59.7	111/120	125/125	108/117	284/292	115/124	125/125	113/121	288/296
			112A	24.0/32.0	66.7/77.0	130/142	150/150	126/137	299/309	134/146	150/150	130/141	303/313
			363A	31.8/42.4	88.4/102.0	157/173	175/175	151/165	320/334	161/177	175/200	155/170	324/338
		HIGH	NONE	—	—	46/46	50/50	49/48	232	50/49	60/60	53/52	236
			117A	7.8/10.4	21.7/25.0	73/77	80/80	74/77	254/257	77/81	80/90	78/81	258/261
			110A	12.0/16.0	33.4/38.5	88/94	90/100	87/92	265/271	92/97	100/100	92/97	269/275
			111A	18.6/24.8	51.7/59.7	111/120	125/125	108/117	284/292	115/124	125/125	113/121	288/296
			112A	24.0/32.0	66.7/77.0	130/142	150/150	126/137	299/309	134/146	150/150	130/141	303/313
			363A	31.8/42.4	88.4/102.0	157/173	175/175	151/165	320/334	161/177	175/200	155/170	324/338
	460-3-60	STD	NONE	—	—	21	25	22	99	23	25	24	101
			116B	13.9	16.7	42	45	41	116	44	45	43	118
			113B	16.5	19.8	46	50	45	119	47	50	47	121
			114B	27.8	33.4	63	70	60	132	64	70	62	134
			115B	33.0	39.7	71	80	67	139	72	80	69	141
			128B	41.7	50.2	84	90	79	149	85	90	82	151
		MED	NONE	—	—	22	25	23	115	24	25	25	117
			116B	13.9	16.7	43	45	42	132	44	45	44	134
			113B	16.5	19.8	47	50	46	135	48	50	48	137
			114B	27.8	33.4	64	70	61	148	65	70	63	150
			115B	33.0	39.7	71	80	68	155	73	80	70	157
			128B	41.7	50.2	85	90	81	165	86	90	83	167
		HIGH	NONE	—	—	22	25	23	115	24	25	25	117
			116B	13.9	16.7	43	45	42	132	44	45	44	134
			113B	16.5	19.8	47	50	46	135	48	50	48	137
			114B	27.8	33.4	64	70	61	148	65	70	63	150
			115B	33.0	39.7	71	80	68	155	73	80	70	157
			128B	41.7	50.2	85	90	81	165	86	90	83	167
	575-3-60	STD	NONE	—	—	16	20	17	81	20	25	21	85
			118A	18.0	17.3	38	40	37	98	41	45	41	102
			119A	36.0	34.6	59	60	56	116	63	70	61	120
		MED	NONE	—	—	18	20	19	94	22	25	23	98
			118A	18.0	17.3	39	40	39	111	43	45	43	115
			119A	36.0	34.6	61	70	58	129	65	70	63	133
HIGH		NONE	—	—	18	20	19	94	22	25	23	98	
		118A	18.0	17.3	39	40	39	111	43	45	43	115	
		119A	36.0	34.6	61	70	58	129	65	70	63	133	

See Legend and Notes on page 69.

Electrical data (cont)

549J*09D — UNIT WIRE/FUSE OR HACR BREAKER SIZING DATA — TWO SPEED INDOOR FAN MOTOR

UNIT	NOM. V-Ph-Hz	IFM TYPE	ELEC. HEATER			NO C.O. or UNPWR C.O.							
			CRHEATER***A00	NOM (kW)	FLA	NO P.E.				w/ P.E. (pwrd fr/unit)			
						MCA	FUSE OR HACR BRKR	DISC. SIZE		MCA	FUSE OR HACR BRKR	DISC. SIZE	
							FLA	LRA			FLA	LRA	
548J*09D	208/230-3-60	STD	NONE	—	—	41/41	50/50	43/42	212	45/45	50/50	47/47	216
			117A	7.8/10.4	21.7/25.0	68/72	70/80	68/71	234/237	72/76	80/80	72/75	238/241
			110A	12.0/16.0	33.4/38.5	83/89	90/90	81/87	245/251	87/93	90/100	85/91	249/255
			111A	18.6/24.8	51.7/59.7	106/116	110/125	102/111	264/272	110/119	110/125	106/115	268/276
			112A	24.0/32.0	66.7/77.0	124/137	125/150	119/131	279/289	128/141	150/150	124/135	283/293
			363A	31.8/42.4	88.4/102.0	152/168	175/175	144/160	300/314	155/172	175/175	149/164	304/318
		MED	NONE	—	—	44/43	50/50	46/45	242	48/47	60/60	50/49	246
			117A	7.8/10.4	21.7/25.0	71/74	80/80	71/74	264/267	75/78	80/80	75/78	268/271
			110A	12.0/16.0	33.4/38.5	86/91	90/100	84/89	275/281	89/95	90/100	89/93	279/285
			111A	18.6/24.8	51.7/59.7	109/118	110/125	105/114	294/302	112/122	125/125	110/118	298/306
			112A	24.0/32.0	66.7/77.0	127/139	150/150	122/133	309/319	131/143	150/150	127/138	313/323
			363A	31.8/42.4	88.4/102.0	154/171	175/175	147/162	330/344	158/174	175/175	152/167	334/348
		HIGH	NONE	—	—	44/43	50/50	46/45	242	48/47	60/60	50/49	246
			117A	7.8/10.4	21.7/25.0	71/74	80/80	71/74	264/267	75/78	80/80	75/78	268/271
			110A	12.0/16.0	33.4/38.5	86/91	90/100	84/89	275/281	89/95	90/100	89/93	279/285
			111A	18.6/24.8	51.7/59.7	109/118	110/125	105/114	294/302	112/122	125/125	110/118	298/306
			112A	24.0/32.0	66.7/77.0	127/139	150/150	122/133	309/319	131/143	150/150	127/138	313/323
			363A	31.8/42.4	88.4/102.0	154/171	175/175	147/162	330/344	158/174	175/175	152/167	334/348
	460-3-60	STD	NONE	—	—	19	25	20	111	21	25	22	113
			116B	13.9	16.7	40	40	39	128	42	45	41	130
			113B	16.5	19.8	44	45	42	131	46	50	44	133
			114B	27.8	33.4	61	70	58	144	63	70	60	146
			115B	33.0	39.7	69	70	65	151	70	80	67	153
			128B	41.7	50.2	82	90	77	161	84	90	79	163
		MED	NONE	—	—	20	25	21	127	22	25	23	129
			116B	13.9	16.7	41	45	40	144	43	45	42	146
			113B	16.5	19.8	45	45	43	147	46	50	45	149
			114B	27.8	33.4	62	70	59	160	63	70	61	162
			115B	33.0	39.7	70	70	66	167	71	80	68	169
			128B	41.7	50.2	83	90	78	177	84	90	80	179
		HIGH	NONE	—	—	20	25	21	127	22	25	23	129
			116B	13.9	16.7	41	45	40	144	43	45	42	146
			113B	16.5	19.8	45	45	43	147	46	50	45	149
			114B	27.8	33.4	62	70	59	160	63	70	61	162
			115B	33.0	39.7	70	70	66	167	71	80	68	169
			128B	41.7	50.2	83	90	78	177	84	90	80	179
	575-3-60	STD	NONE	—	—	17	20	17	87	21	25	21	91
			118A	18.0	17.3	38	40	37	104	42	45	41	108
			119A	36.0	34.6	60	60	57	122	64	70	61	126
		MED	NONE	—	—	18	20	19	100	22	25	23	104
			118A	18.0	17.3	40	40	39	117	44	45	43	121
			119A	36.0	34.6	62	70	59	135	66	70	63	139
HIGH		NONE	—	—	18	20	19	100	22	25	23	104	
		118A	18.0	17.3	40	40	39	117	44	45	43	121	
		119A	36.0	34.6	62	70	59	135	66	70	63	139	

See Legend and Notes on page 69.

549J*09D — UNIT WIRE/FUSE OR HACR BREAKER SIZING DATA — TWO SPEED INDOOR FAN MOTOR (cont)

UNIT	NOM. V-Ph-Hz	IFM TYPE	ELEC. HEATER			w/ PWRD C.O.							
			CRHEATER***A00	NOM (kW)	FLA	NO P.E.				w/ P.E. (pwrd fr/unit)			
						MCA	FUSE OR HACR BRKR	DISC. SIZE		MCA	FUSE OR HACR BRKR	DISC. SIZE	
				FLA	LRA			FLA	LRA				
549J*09D	208/230-3-60	STD	NONE	—	—	46/46	50/50	48/48	217	50/49	60/60	52/52	221
			117A	7.8/10.4	21.7/25.0	73/77	80/80	73/77	239/242	77/81	80/90	77/81	243/246
			110A	12.0/16.0	33.4/38.5	88/94	90/100	86/92	250/256	91/98	100/100	91/96	254/260
			111A	18.6/24.8	51.7/59.7	111/120	125/125	108/116	269/277	114/124	125/125	112/121	273/281
			112A	24.0/32.0	66.7/77.0	129/142	150/150	125/136	284/294	133/146	150/150	129/141	288/298
			363A	31.8/42.4	88.4/102.0	156/173	175/175	150/165	305/319	160/177	175/200	154/170	309/323
		MED	NONE	—	—	49/48	60/60	51/50	247	52/52	60/60	56/55	251
			117A	7.8/10.4	21.7/25.0	76/79	80/80	76/79	269/272	80/83	80/90	81/83	273/276
			110A	12.0/16.0	33.4/38.5	90/96	90/100	90/95	280/286	94/100	100/100	94/99	284/290
			111A	18.6/24.8	51.7/59.7	113/123	125/125	111/119	299/307	117/126	125/150	115/123	303/311
			112A	24.0/32.0	66.7/77.0	132/144	150/150	128/139	314/324	136/148	150/150	132/143	318/328
			363A	31.8/42.4	88.4/102.0	159/175	175/175	153/168	335/349	163/179	175/200	157/172	339/353
		HIGH	NONE	—	—	49/48	60/60	51/50	247	52/52	60/60	56/55	251
			117A	7.8/10.4	21.7/25.0	76/79	80/80	76/79	269/272	80/83	80/90	81/83	273/276
			110A	12.0/16.0	33.4/38.5	90/96	90/100	90/95	280/286	94/100	100/100	94/99	284/290
			111A	18.6/24.8	51.7/59.7	113/123	125/125	111/119	299/307	117/126	125/150	115/123	303/311
			112A	24.0/32.0	66.7/77.0	132/144	150/150	128/139	314/324	136/148	150/150	132/143	318/328
			363A	31.8/42.4	88.4/102.0	159/175	175/175	153/168	335/349	163/179	175/200	157/172	339/353
	460-3-60	STD	NONE	—	—	21	25	22	113	23	25	24	115
			116B	13.9	16.7	42	45	41	130	44	45	43	132
			113B	16.5	19.8	46	50	45	133	48	50	47	135
			114B	27.8	33.4	63	70	60	146	65	70	63	148
			115B	33.0	39.7	71	80	68	153	73	80	70	155
			128B	41.7	50.2	84	90	80	163	86	90	82	165
		MED	NONE	—	—	22	25	23	129	24	30	25	131
			116B	13.9	16.7	43	45	42	146	45	45	44	148
			113B	16.5	19.8	47	50	46	149	49	50	48	151
			114B	27.8	33.4	64	70	62	162	66	70	64	164
			115B	33.0	39.7	72	80	69	169	74	80	71	171
			128B	41.7	50.2	85	90	81	179	87	90	83	181
		HIGH	NONE	—	—	22	25	23	129	24	30	25	131
			116B	13.9	16.7	43	45	42	146	45	45	44	148
			113B	16.5	19.8	47	50	46	149	49	50	48	151
			114B	27.8	33.4	64	70	62	162	66	70	64	164
			115B	33.0	39.7	72	80	69	169	74	80	71	171
			128B	41.7	50.2	85	90	81	179	87	90	83	181
	575-3-60	STD	NONE	—	—	18	20	19	89	22	25	23	93
			118A	18.0	17.3	40	40	39	106	44	45	43	110
			119A	36.0	34.6	62	70	59	124	66	70	63	128
		MED	NONE	—	—	20	25	21	102	24	30	25	106
			118A	18.0	17.3	42	45	41	119	46	50	45	123
			119A	36.0	34.6	63	70	61	137	67	70	65	141
		HIGH	NONE	—	—	20	25	21	102	24	30	25	106
			118A	18.0	17.3	42	45	41	119	46	50	45	123
			119A	36.0	34.6	63	70	61	137	67	70	65	141

See Legend and Notes on page 69.

Electrical data (cont)

549J*12D — UNIT WIRE/FUSE OR HACR BREAKER SIZING DATA — TWO SPEED INDOOR FAN MOTOR

UNIT	NOM. V-Ph-Hz	IFM TYPE	ELEC. HEATER			NO C.O. or UNPWR C.O.							
			CRHEATER***A00	NOM (kW)	FLA	NO P.E.				w/ P.E. (pwrd fr/unit)			
						MCA	FUSE OR HACR BRKR	DISC. SIZE		MCA	FUSE OR HACR BRKR	DISC. SIZE	
								FLA	LRA			FLA	LRA
549J*12D	208/230-3-60	STD	NONE	—	—	49/49	60/60	52/51	279	53/53	60/60	56/56	283
			117A	7.8/10.4	21.7/25.0	76/80	80/80	76/80	301/304	80/84	80/90	81/84	305/308
			110A	12.0/16.0	33.4/38.5	91/97	100/100	90/95	312/318	95/101	100/110	94/100	316/322
			112A	24.0/32.0	66.7/77.0	133/145	150/150	128/140	346/356	136/149	150/150	133/144	350/360
			363A	31.8/42.4	88.4/102.0	160/176	175/200	153/168	367/381	164/180	175/200	158/173	371/385
			364A	37.6/50.0	104.2/120.3	179/169	200/175	171/190	383/399	183/173	200/200	176/194	387/403
		MED	NONE	—	—	53/52	60/60	56/55	329	57/56	70/60	60/59	333
			117A	7.8/10.4	21.7/25.0	80/83	80/90	81/83	351/354	84/87	90/90	85/88	355/358
			110A	12.0/16.0	33.4/38.5	95/100	100/100	94/99	362/368	98/104	100/110	99/103	366/372
			112A	24.0/32.0	66.7/77.0	136/148	150/150	132/143	396/406	140/152	150/175	137/148	400/410
			363A	31.8/42.4	88.4/102.0	163/179	175/200	157/172	417/431	167/183	175/200	162/176	421/435
			364A	37.6/50.0	104.2/120.3	183/172	200/200	176/193	433/449	187/176	200/200	180/197	437/453
		HIGH	NONE	—	—	56/55	60/60	59/58	340	60/59	70/70	63/62	344
			117A	7.8/10.4	21.7/25.0	83/86	90/90	84/87	362/365	87/90	90/90	88/91	366/369
			110A	12.0/16.0	33.4/38.5	97/103	100/110	97/102	373/379	101/107	110/110	102/107	377/383
			112A	24.0/32.0	66.7/77.0	139/151	150/175	136/147	407/417	143/155	150/175	140/151	411/421
			363A	31.8/42.4	88.4/102.0	166/182	175/200	161/175	428/442	170/186	175/200	165/180	432/446
			364A	37.6/50.0	104.2/120.3	186/175	200/200	179/196	444/460	190/179	200/200	183/201	448/464
	460-3-60	STD	NONE	—	—	24	30	25	134	26	30	27	136
			116B	13.9	16.7	45	45	44	151	47	50	46	153
			113B	16.5	19.8	49	50	48	154	51	60	50	156
			115B	33.0	39.7	74	80	71	174	76	80	73	176
			128B	41.7	50.2	87	90	83	184	89	90	85	186
			129B	50.0	60.1	84	90	94	194	86	90	96	196
		MED	NONE	—	—	26	30	27	159	28	30	29	161
			116B	13.9	16.7	47	50	46	176	48	50	48	178
			113B	16.5	19.8	51	60	50	179	52	60	52	181
			115B	33.0	39.7	75	80	73	199	77	80	75	201
			128B	41.7	50.2	89	90	85	209	90	90	87	211
			129B	50.0	60.1	86	90	96	219	88	90	98	221
		HIGH	NONE	—	—	27	30	29	164	29	35	31	166
			116B	13.9	16.7	48	50	48	181	50	50	50	183
			113B	16.5	19.8	52	60	51	184	54	60	53	186
			115B	33.0	39.7	77	80	74	204	79	80	76	206
			128B	41.7	50.2	90	90	86	214	92	100	88	216
			129B	50.0	60.1	87	90	98	224	89	100	100	226
	575-3-60	STD	NONE	—	—	19	25	20	107	23	25	24	111
			118A	18.0	17.3	41	45	40	124	45	45	44	128
			119A	36.0	34.6	63	70	60	142	66	70	64	146
			380A	54.0	52.0	71	80	80	159	75	80	84	163
		MED	NONE	—	—	20	25	21	116	24	30	26	120
			118A	18.0	17.3	42	45	41	133	46	50	46	137
119A			36.0	34.6	64	70	61	151	67	70	65	155	
380A			54.0	52.0	72	80	81	168	76	80	85	172	
HIGH		NONE	—	—	22	25	23	130	26	30	28	134	
		118A	18.0	17.3	44	45	43	147	48	50	47	151	
		119A	36.0	34.6	65	70	63	165	69	70	67	169	
		380A	54.0	52.0	74	80	83	182	78	80	87	186	

See Legend and Notes on page 69.

549J*12D — UNIT WIRE/FUSE OR HACR BREAKER SIZING DATA — TWO SPEED INDOOR FAN MOTOR (cont)

UNIT	NOM. V-Ph-Hz	IFM TYPE	ELEC. HEATER			w/ PWRD C.O.								
			CRHEATER***A00	NOM (kW)	FLA	NO P.E.				w/ P.E. (pwrd fr/unit)				
						MCA	FUSE OR HACR BRKR	DISC. SIZE		MCA	FUSE OR HACR BRKR	DISC. SIZE		
				FLA	LRA			FLA	LRA					
549J*12D	208/230-3-60	STD	NONE	—	—	54/54	60/60	57/57	284	58/58	70/70	61/61	288	
			117A	7.8/10.4	21.7/25.0	81/85	90/90	82/85	306/309	85/89	90/90	86/90	310/313	
			110A	12.0/16.0	33.4/38.5	96/102	100/110	95/101	317/323	100/106	100/110	100/105	321/327	
			112A	24.0/32.0	66.7/77.0	137/150	150/150	134/145	351/361	141/154	150/175	138/150	355/365	
			363A	31.8/42.4	88.4/102.0	165/181	175/200	159/174	372/386	168/185	175/200	163/178	376/390	
			364A	37.6/50.0	104.2/120.3	184/174	200/200	177/195	388/404	188/178	200/200	181/199	392/408	
		MED	NONE	—	—	58/57	70/70	61/60	334	62/61	70/70	66/65	338	
			117A	7.8/10.4	21.7/25.0	85/88	90/90	86/89	356/359	89/92	90/100	91/93	360/363	
			110A	12.0/16.0	33.4/38.5	99/105	100/110	100/104	367/373	103/109	110/110	104/109	371/377	
			112A	24.0/32.0	66.7/77.0	141/153	150/175	138/149	401/411	145/157	150/175	142/153	405/415	
			363A	31.8/42.4	88.4/102.0	168/184	175/200	163/177	422/436	172/188	175/200	167/182	426/440	
			364A	37.6/50.0	104.2/120.3	188/177	200/200	181/198	438/454	192/181	200/200	185/203	442/458	
		HIGH	NONE	—	—	61/60	70/70	65/63	345	64/63	70/70	69/68	349	
			117A	7.8/10.4	21.7/25.0	88/91	90/100	89/92	367/370	91/95	100/100	94/97	371/374	
			110A	12.0/16.0	33.4/38.5	102/108	110/110	103/108	378/384	106/112	110/125	107/112	382/388	
			112A	24.0/32.0	66.7/77.0	144/156	150/175	141/152	412/422	148/160	150/175	146/156	416/426	
			363A	31.8/42.4	88.4/102.0	171/187	175/200	166/181	433/447	175/191	175/200	171/185	437/451	
			364A	37.6/50.0	104.2/120.3	191/180	200/200	184/202	449/465	195/184	200/200	189/206	453/469	
		460-3-60	STD	NONE	—	—	26	30	28	136	28	30	30	138
				116B	13.9	16.7	47	50	47	153	49	50	49	155
				113B	16.5	19.8	51	60	50	156	53	60	53	158
				115B	33.0	39.7	76	80	73	176	78	80	75	178
				128B	41.7	50.2	89	90	85	186	91	100	88	188
				129B	50.0	60.1	87	90	97	196	88	90	99	198
	MED		NONE	—	—	28	30	29	161	30	35	32	163	
			116B	13.9	16.7	49	50	49	178	51	60	51	180	
			113B	16.5	19.8	53	60	52	181	55	60	54	183	
			115B	33.0	39.7	78	80	75	201	79	80	77	203	
			128B	41.7	50.2	91	100	87	211	93	100	89	213	
			129B	50.0	60.1	88	90	99	221	90	100	101	223	
	HIGH		NONE	—	—	29	35	31	166	31	35	33	168	
			116B	13.9	16.7	50	50	50	183	52	60	52	185	
			113B	16.5	19.8	54	60	54	186	56	60	56	188	
			115B	33.0	39.7	79	80	77	206	81	90	79	208	
			128B	41.7	50.2	92	100	89	216	94	100	91	218	
			129B	50.0	60.1	90	100	100	226	91	100	102	228	
	575-3-60		STD	NONE	—	—	21	25	22	109	25	30	26	113
				118A	18.0	17.3	43	45	42	126	47	50	46	130
				119A	36.0	34.6	64	70	62	144	68	70	66	148
				380A	54.0	52.0	73	80	82	161	77	80	86	165
			MED	NONE	—	—	22	25	23	118	26	30	28	122
				118A	18.0	17.3	44	45	43	135	48	50	47	139
		119A		36.0	34.6	65	70	63	153	69	70	67	157	
		380A		54.0	52.0	74	80	83	170	78	80	87	174	
		HIGH	NONE	—	—	24	30	25	132	28	30	30	136	
			118A	18.0	17.3	46	50	45	149	49	50	49	153	
			119A	36.0	34.6	67	70	65	167	71	80	69	171	
			380A	54.0	52.0	76	80	85	184	80	90	89	188	

See Legend and Notes on page 69.

Electrical data (cont)

549J*14D — UNIT WIRE/FUSE OR HACR BREAKER SIZING DATA — TWO SPEED INDOOR FAN MOTOR

UNIT	NOM. V-Ph-Hz	IFM TYPE	ELEC. HEATER			NO C.O. or UNPWR C.O.							
			CRHEATER***A00	NOM (kW)	FLA	NO P.E.				w/ P.E. (pwrd fr/unit)			
						MCA	FUSE OR HACR BRKR	DISC. SIZE		MCA	FUSE OR HACR BRKR	DISC. SIZE	
								FLA	LRA			FLA	LRA
549J*14D	208/230-3-60	STD	NONE	—	—	64/63	80/80	67/66	363	68/67	80/80	71/70	367
			291A	12.4/16.5	34.4/39.7	107/113	110/125	106/111	397/403	111/117	125/125	111/116	401/407
			370A	19.9/26.5	55.3/63.8	133/143	150/150	130/139	418/427	137/147	150/150	135/143	422/431
			294A	25.2/33.5	69.9/80.6	151/164	175/175	147/158	433/444	155/168	175/175	151/163	437/448
			367A	32.7/43.5	90.7/104.7	177/194	200/200	171/186	454/468	181/198	200/200	175/190	458/472
			368A	37.6/50.0	104.3/120.3	194/183	200/200	187/204	467/483	198/187	200/200	191/208	471/487
		MED	NONE	—	—	64/63	80/80	67/66	363	68/67	80/80	71/70	367
			291A	12.4/16.5	34.4/39.7	107/113	110/125	106/111	397/403	111/117	125/125	111/116	401/407
			370A	19.9/26.5	55.3/63.8	133/143	150/150	130/139	418/427	137/147	150/150	135/143	422/431
			294A	25.2/33.5	69.9/80.6	151/164	175/175	147/158	433/444	155/168	175/175	151/163	437/448
			367A	32.7/43.5	90.7/104.7	177/194	200/200	171/186	454/468	181/198	200/200	175/190	458/472
			368A	37.6/50.0	104.3/120.3	194/183	200/200	187/204	467/483	198/187	200/200	191/208	471/487
		HIGH	NONE	—	—	72	80	76	402	76	90	81	406
			291A	12.4/16.5	34.4/39.7	115/122	125/125	116/122	436/442	119/126	125/150	120/126	440/446
			370A	19.9/26.5	55.3/63.8	142/152	150/175	140/150	457/466	145/156	150/175	144/154	461/470
			294A	25.2/33.5	69.9/80.6	160/173	175/175	157/169	472/483	164/177	175/200	161/173	476/487
			367A	32.7/43.5	90.7/104.7	186/203	200/225	181/197	493/507	190/207	200/225	185/201	497/511
			368A	37.6/50.0	104.3/120.3	203/193	225/200	196/215	506/522	207/197	225/225	201/219	510/526
	460-3-60	STD	NONE	—	—	31	40	32	183	32	40	34	185
			292A	16.5	19.9	55	60	54	203	57	60	56	205
			377A	26.5	31.9	70	70	68	215	72	80	70	217
			295A	33.5	40.3	81	90	78	223	83	90	80	225
			374A	43.5	52.3	96	100	92	235	98	100	94	237
			375A	50.0	60.2	91	100	101	243	93	100	103	245
		MED	NONE	—	—	31	40	32	183	32	40	34	185
			292A	16.5	19.9	55	60	54	203	57	60	56	205
			377A	26.5	31.9	70	70	68	215	72	80	70	217
			295A	33.5	40.3	81	90	78	223	83	90	80	225
			374A	43.5	52.3	96	100	92	235	98	100	94	237
			375A	50.0	60.2	91	100	101	243	93	100	103	245
		HIGH	NONE	—	—	35	45	37	202	37	45	39	204
			292A	16.5	19.9	60	60	60	222	62	70	62	224
			377A	26.5	31.9	75	80	74	234	77	80	76	236
			295A	33.5	40.3	86	90	83	242	87	90	85	244
			374A	43.5	52.3	101	110	97	254	102	110	99	256
			375A	50.0	60.2	96	100	106	262	97	100	108	264
575-3-60	STD	NONE	—	—	26	30	27	136	30	35	32	140	
		293A	16.5	15.9	46	50	45	152	50	50	50	156	
		384A	26.5	25.5	58	60	56	162	62	70	61	166	
		296A	33.5	32.2	66	70	64	168	70	70	69	172	
		381A	43.5	41.9	79	80	75	178	82	90	80	182	
		382A	50.0	48.1	74	80	82	184	78	80	87	188	
	MED	NONE	—	—	26	30	27	136	30	35	32	140	
		293A	16.5	15.9	46	50	45	152	50	50	50	156	
		384A	26.5	25.5	58	60	56	162	62	70	61	166	
		296A	33.5	32.2	66	70	64	168	70	70	69	172	
		381A	43.5	41.9	79	80	75	178	82	90	80	182	
		382A	50.0	48.1	74	80	82	184	78	80	87	188	
	HIGH	NONE	—	—	31	35	32	148	35	40	37	152	
		293A	16.5	15.9	51	60	51	164	54	60	55	168	
		384A	26.5	25.5	63	70	62	174	66	70	66	178	
		296A	33.5	32.2	71	80	69	180	75	80	74	184	
		381A	43.5	41.9	83	90	81	190	87	90	85	194	
		382A	50.0	48.1	79	90	88	196	83	90	92	200	

See Legend and Notes on page 69.

549J*14D — UNIT WIRE/FUSE OR HACR BREAKER SIZING DATA — TWO SPEED INDOOR FAN MOTOR (cont)

UNIT	NOM. V-Ph-Hz	IFM TYPE	ELEC. HEATER			w/ PWRD C.O.							
			CRHEATER***A00	NOM (kW)	FLA	NO P.E.				w/ P.E. (pwrd fr/unit)			
						MCA	FUSE OR HACR BRKR	DISC. SIZE		MCA	FUSE OR HACR BRKR	DISC. SIZE	
								FLA	LRA			FLA	LRA
549J*14D	208/230-3-60	STD	NONE	—	—	69/68	80/80	72/71	368	73/72	80/80	76/76	372
			291A	12.4/16.5	34.4/39.7	112/118	125/125	112/117	402/408	116/121	125/125	116/121	406/412
			370A	19.9/26.5	55.3/63.8	138/148	150/150	136/145	423/432	142/152	150/175	140/149	427/436
			294A	25.2/33.5	69.9/80.6	156/169	175/175	152/164	438/449	160/173	175/175	157/168	442/453
			367A	32.7/43.5	90.7/104.7	182/199	200/200	176/192	459/473	186/203	200/225	181/196	463/477
			368A	37.6/50.0	104.3/120.3	199/188	200/200	192/210	472/488	203/192	225/200	196/214	476/492
		MED	NONE	—	—	69/68	80/80	72/71	368	73/72	80/80	76/76	372
			291A	12.4/16.5	34.4/39.7	112/118	125/125	112/117	402/408	116/121	125/125	116/121	406/412
			370A	19.9/26.5	55.3/63.8	138/148	150/150	136/145	423/432	142/152	150/175	140/149	427/436
			294A	25.2/33.5	69.9/80.6	156/169	175/175	152/164	438/449	160/173	175/175	157/168	442/453
			367A	32.7/43.5	90.7/104.7	182/199	200/200	176/192	459/473	186/203	200/225	181/196	463/477
			368A	37.6/50.0	104.3/120.3	199/188	200/200	192/210	472/488	203/192	225/200	196/214	476/492
		HIGH	NONE	—	—	77	90	82	407	81	100	86	411
			291A	12.4/16.5	34.4/39.7	120/127	125/150	121/128	441/447	124/131	125/150	126/132	445/451
			370A	19.9/26.5	55.3/63.8	146/157	150/175	145/155	462/471	150/161	150/175	150/160	466/475
			294A	25.2/33.5	69.9/80.6	165/178	175/200	162/175	477/488	168/182	175/200	167/179	481/492
			367A	32.7/43.5	90.7/104.7	191/208	200/225	186/202	498/512	194/212	200/225	191/207	502/516
			368A	37.6/50.0	104.3/120.3	208/198	225/225	202/220	511/527	211/201	225/225	206/225	515/531
	460-3-60	STD	NONE	—	—	33	40	34	185	35	40	36	187
			292A	16.5	19.9	58	60	57	205	59	60	59	207
			377A	26.5	31.9	73	80	71	217	74	80	73	219
			295A	33.5	40.3	83	90	80	225	85	90	82	227
			374A	43.5	52.3	98	100	94	237	100	100	96	239
			375A	50.0	60.2	93	100	103	245	95	100	105	247
		MED	NONE	—	—	33	40	34	185	35	40	36	187
			292A	16.5	19.9	58	60	57	205	59	60	59	207
			377A	26.5	31.9	73	80	71	217	74	80	73	219
			295A	33.5	40.3	83	90	80	225	85	90	82	227
			374A	43.5	52.3	98	100	94	237	100	100	96	239
			375A	50.0	60.2	93	100	103	245	95	100	105	247
		HIGH	NONE	—	—	38	45	40	204	39	45	42	206
			292A	16.5	19.9	62	70	62	224	64	70	65	226
			377A	26.5	31.9	77	80	76	236	79	80	78	238
			295A	33.5	40.3	88	90	86	244	90	90	88	246
			374A	43.5	52.3	103	110	100	256	105	110	102	258
			375A	50.0	60.2	98	100	109	264	100	110	111	266
	575-3-60	STD	NONE	—	—	28	30	29	138	32	35	33	142
			293A	16.5	15.9	48	50	47	154	52	60	52	158
			384A	26.5	25.5	60	60	58	164	64	70	63	168
			296A	33.5	32.2	68	70	66	170	72	80	70	174
			381A	43.5	41.9	80	80	77	180	84	90	82	184
			382A	50.0	48.1	76	80	84	186	80	90	89	190
MED		NONE	—	—	28	30	29	138	32	35	33	142	
		293A	16.5	15.9	48	50	47	154	52	60	52	158	
		384A	26.5	25.5	60	60	58	164	64	70	63	168	
		296A	33.5	32.2	68	70	66	170	72	80	70	174	
		381A	43.5	41.9	80	80	77	180	84	90	82	184	
		382A	50.0	48.1	76	80	84	186	80	90	89	190	
HIGH		NONE	—	—	33	40	34	150	36	40	39	154	
		293A	16.5	15.9	52	60	53	166	56	60	57	170	
		384A	26.5	25.5	64	70	64	176	68	70	68	180	
		296A	33.5	32.2	73	80	71	182	77	80	76	186	
		381A	43.5	41.9	85	90	82	192	89	90	87	196	
		382A	50.0	48.1	81	90	90	198	84	90	94	202	

See Legend and Notes on page 69.

TYPICAL CONTROL WIRING DIAGRAM: 1-STAGE UNIT WITH ELECTRO-MECHANICAL CONTROL SHOWN

Typical wiring diagrams

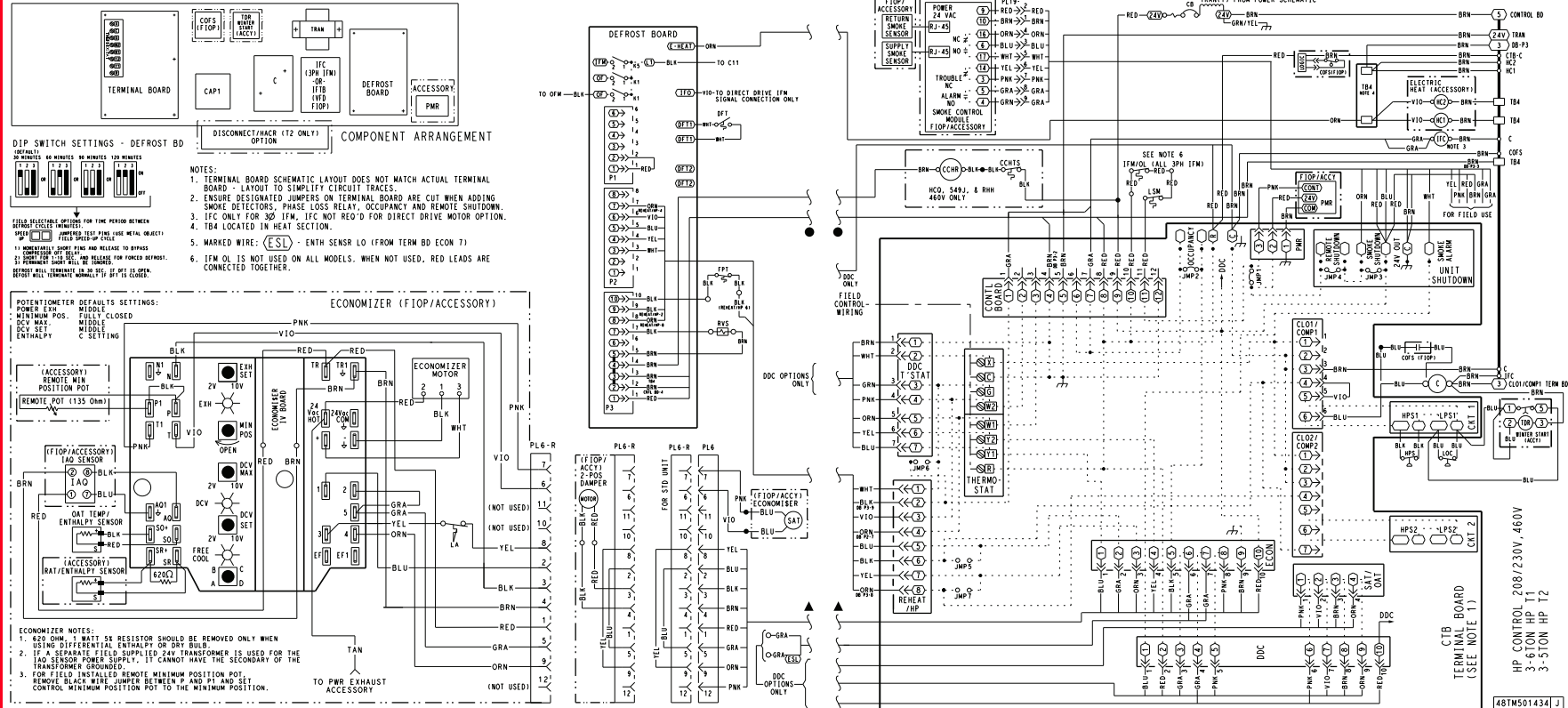

NOTE: For details pertaining to a specific unit, see the Control Wiring Diagram label on the unit.

TYPICAL 548J*08-09 POWER WIRING DIAGRAM

HP POWER 208/230V, 460V, 575V 3 PH. 7.5-8.5TON HP (1)COMPR T1
7.5TON HP (1)COMPR T2

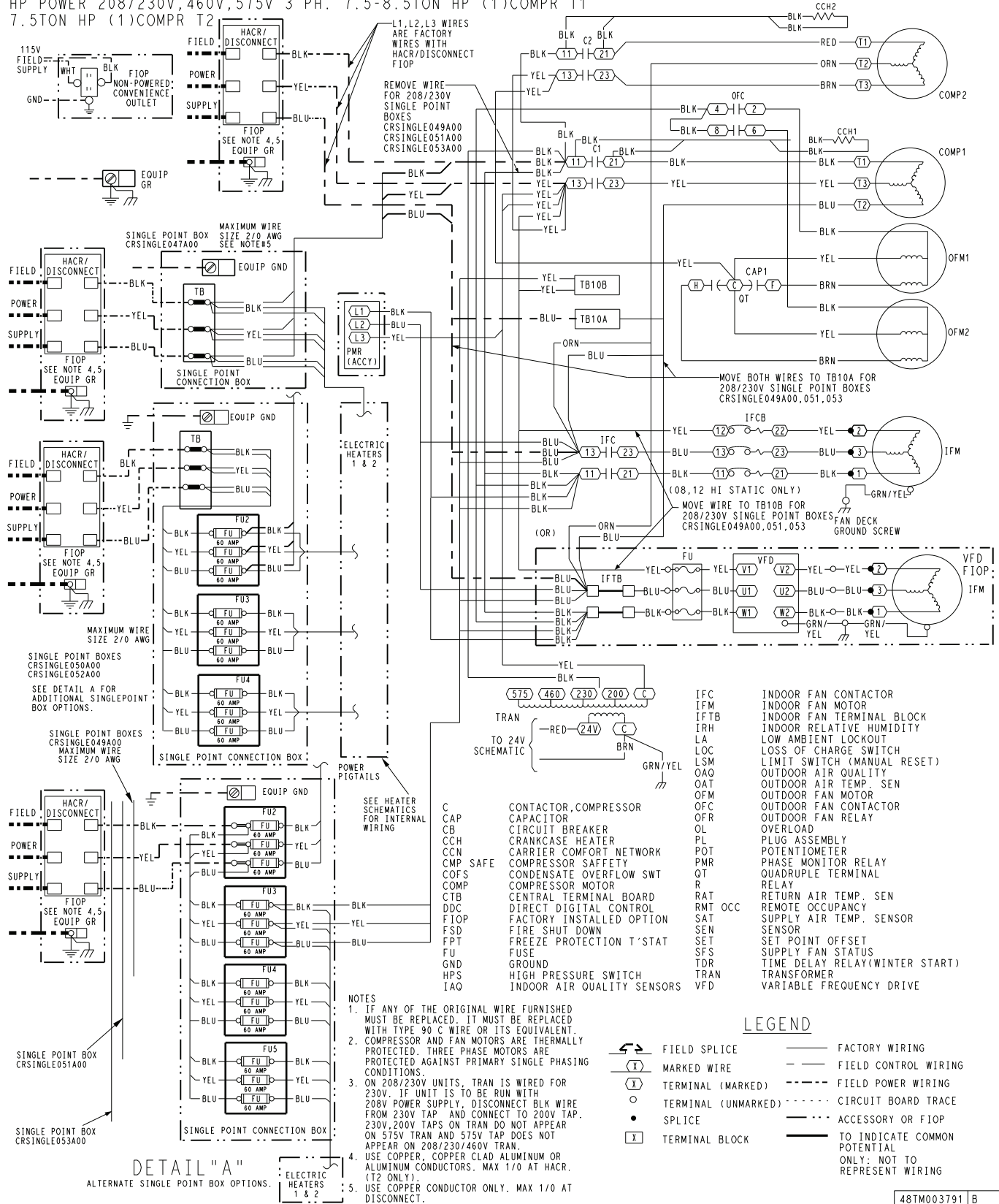

DETAIL "A"

ALTERNATE SINGLE POINT BOX OPTIONS.

- NOTES**
1. IF ANY OF THE ORIGINAL WIRE FURNISHED MUST BE REPLACED, IT MUST BE REPLACED WITH TYPE 90 C WIRE OR ITS EQUIVALENT.
 2. COMPRESSOR AND FAN MOTORS ARE THERMALLY PROTECTED. THREE PHASE MOTORS ARE PROTECTED AGAINST PRIMARY SINGLE PHASING CONDITIONS.
 3. ON 208/230V UNITS, TRAN IS WIRED FOR 230V. IF UNIT IS TO BE RUN WITH 208V POWER SUPPLY, DISCONNECT BLK WIRE FROM 230V TAP AND CONNECT TO 200V TAP. 230V, 200V TAPS ON TRAN DO NOT APPEAR ON 575V TRAN AND 575V TAP DOES NOT APPEAR ON 208/230/460V TRAN.
 4. USE COPPER, COPPER CLAD ALUMINUM OR ALUMINUM CONDUCTORS. MAX 1/0 AT HACR. (T2 ONLY).
 5. USE COPPER CONDUCTOR ONLY. MAX 1/0 AT DISCONNECT.

LEGEND

- FIELD SPLICE
- MARKED WIRE
- TERMINAL (MARKED)
- TERMINAL (UNMARKED)
- SPLICE
- TERMINAL BLOCK
- FACTORY WIRING
- FIELD CONTROL WIRING
- FIELD POWER WIRING
- CIRCUIT BOARD TRACE
- ACCESSORY OR FIOP
- TO INDICATE COMMON POTENTIAL ONLY: NOT TO REPRESENT WIRING

48TM003791 B

NOTE: For details pertaining to a specific unit, see the Control Wiring Diagram label on the unit.

Typical wiring diagrams (cont)

TYPICAL 548J*12 POWER WIRING DIAGRAM (208/230-3-60 UNIT SHOWN)

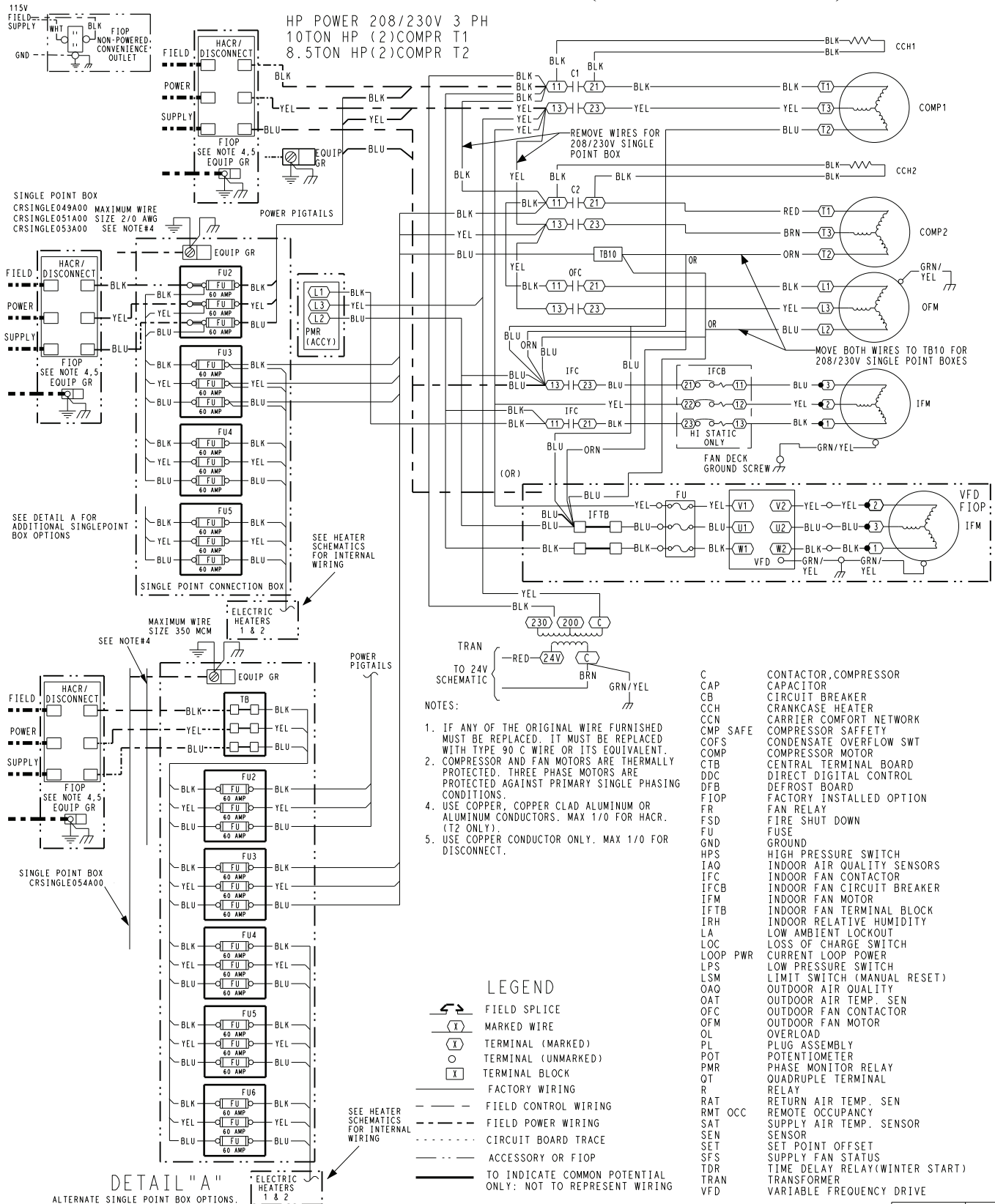

NOTE: For details pertaining to a specific unit, see the Control Wiring Diagram label on the unit.

48TM003793 B

TYPICAL 548J*14 POWER WIRING DIAGRAM (208/230-3-60 UNIT SHOWN)

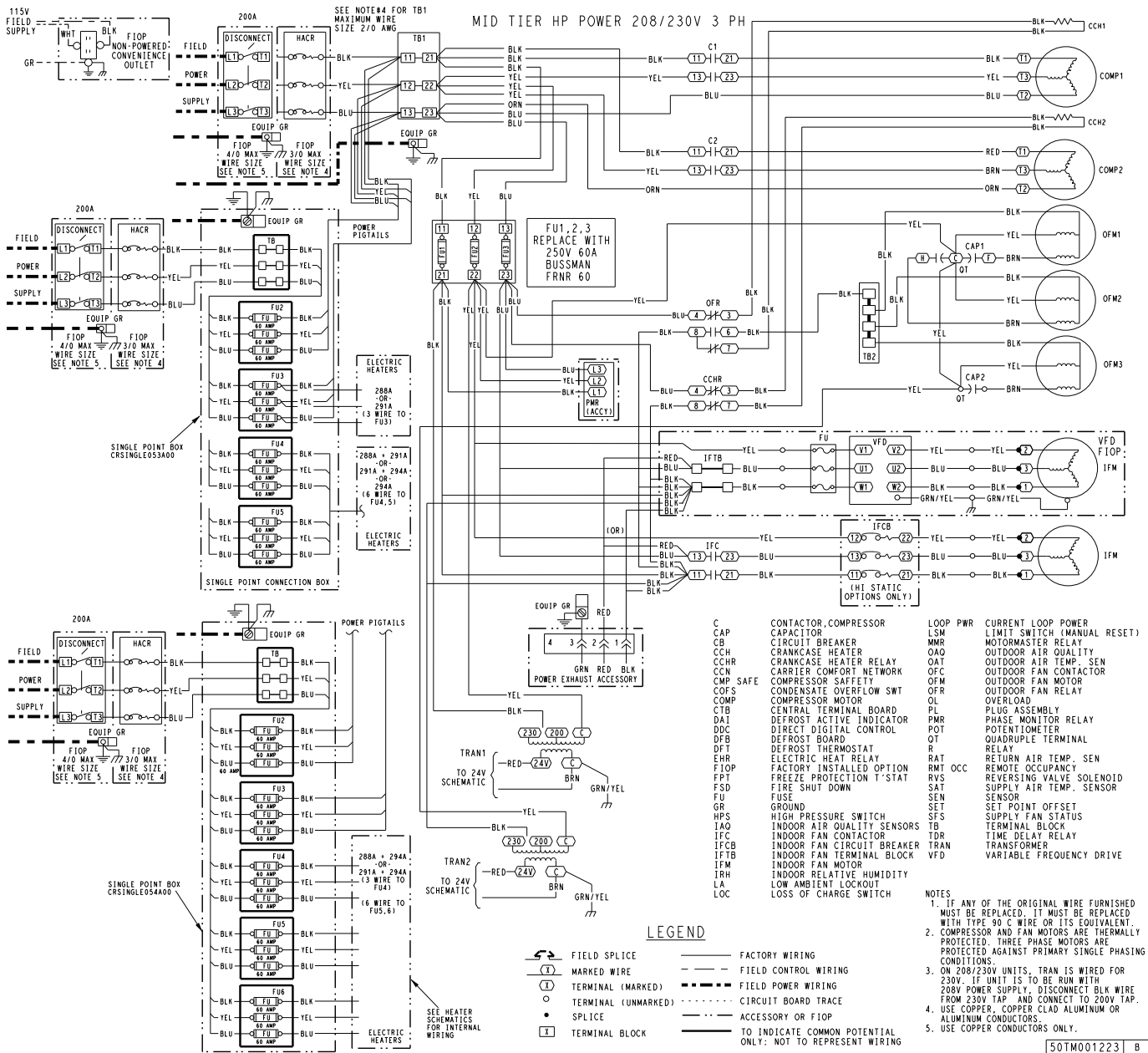

NOTE: For details pertaining to a specific unit, see the Control Wiring Diagram label on the unit.

Sequence of operation

Cooling, unit without economizer

Cooling (Single speed indoor fan motor)

When thermostat calls for cooling, terminals G and Y1 are energized. The indoor fan contactor (IFC), reversing valve solenoid (RVS) and compressor contactor are energized and indoor fan motor, compressor, and outdoor fan start. The outdoor fan motor runs continuously while unit is cooling.

Two-stage models

If Stage 1 cooling does not satisfy the space load, the space temperature will rise until thermostat calls for Stage 2 cooling (Y2 closes). Defrost Board activates Stage 2 Compressor. Reversing valve 2 switches to Cooling position. Compressor 2 contactor is energized; Compressor 2 starts and Circuit 2 operates in Cooling mode.

When Cooling Stage 2 is satisfied, thermostat Y2 opens. Compressor 2 contactor is de-energized; Compressor 2 stops. Reversing Valve 2 remains energized.

When Cooling Stage 1 is satisfied, thermostat Y1 opens. Compressor 1 contactor is de-energized; Compressor 1 stops. Outdoor fan relay is de-energized; outdoor fans stop. After the Fan Delay period, the indoor fan contactor is de-energized; indoor fan stops (unless Continuous Fan operation has been selected). Reversing Valve 1 remains energized.

Reversing valve solenoids are energized in Cooling modes. Each solenoid will remain energized until the next Heating mode is initiated for this circuit.

Cooling (2-speed indoor fan motor)

Per ASHRAE 90.1-2016 and IECC-2015 standards, during the first stage of cooling operation the VFD will adjust the fan motor to provide 66% of the total cfm established for the unit. When a call for the second stage of cooling is required, the VFD will allow the total cfm for the unit established (100%). This is standard on all models for installation in the United States to meet U.S. Department of Energy - 2018 IEER efficiency rating.

Heating, unit without economizer

Upon a request for heating from the space thermostat, terminal W1 will be energized with 24V. The IFC, outdoor fan contactor (OFC), C1, and C2 will be energized. The indoor fan, outdoor fans, and compressor no. 1, and compressor no. 2 are energized and reversing valves are de-energized and switch position.

If the space temperature continues to fall while W1 is energized, W2 will be energized with 24V, and the heater contactor(s) (HC) will be energized, which will energize the electric heater(s).

When the space thermostat is satisfied, W2 will be de-energized first, and the electric heater(s) will be de-energized.

Upon a further rise in space temperature, W1 will be de-energized.

Two compressor models

When the thermostat calls for heating, terminal W1 is energized. Defrost Board de-energizes both reversing valve solenoids and reversing valves move to Heating position. The indoor fan contactor is energized; indoor fan motor starts. Outdoor fan relay is energized; both outdoor fan motors run. Compressor contactors C1 and C2 are energized; both refrigeration circuits operate in Heating mode.

If Stage 1 heating does not satisfy the space load, the space temperature will fall until thermostat calls for Stage 2 heating (W2 closes). Terminal W2 is energized. Defrost Board issues an output at EHEAT. Heater contactor 1 and heater contactor 2 (if installed) are energized; all electric heaters are energized.

When space heating load is partially satisfied, thermostat terminal W2 is de-energized; heater contactors are de-energized and all electric heat is terminated. Stage 1 heating continues.

When the space heating load is fully satisfied, thermostat terminal W1 is also de-energized.

Reversing valve solenoids remain de-energized until the next call for Cooling mode is initiated.

Cooling, unit with EconoMiSer® IV

When free cooling is not available, the compressors will be controlled by the zone thermostat. When free cooling is available, the outdoor air damper is modulated by the EconoMiSer IV control to provide a 50°F to 55°F (10°C to 13°C) mixed air temperature into the zone. As the mixed air temperature fluctuates above 55°F or below 50°F (13°C to 10°C), the dampers will be modulated (open or close) to bring the mixed air temperature back within control.

If mechanical cooling is utilized with free cooling, the outdoor air damper will maintain its current position at the time the compressor is started. If the increase in cooling capacity causes the mixed air temperature to drop below 45°F (7°C), then the outdoor air damper position will be decreased to the minimum position. If the mixed air temperature continues to fall, the outdoor air damper will close. Control returns to normal once the mixed air temperature rises above 48°F (9°C).

If optional power exhaust is installed, as the outdoor air damper opens and closes, the power exhaust fans will be energized and de-energized.

If field-installed accessory CO₂ sensors are connected to the EconoMiSer IV control, a demand controlled ventilation strategy will begin to operate. As the CO₂ level in the zone increases above the CO₂ setpoint, the minimum position of the damper will be increased proportionally. As the CO₂ level decreases because of the increase in fresh air, the outdoor air damper will be proportionally closed.

For EconoMiSer IV operation, there must be a thermostat call for the fan (G). If the unit is occupied and the fan is on, the damper will operate at minimum position. Otherwise, the damper will be closed.

When the EconoMiSer IV control is in the occupied mode and a call for cooling exists (Y1 on the thermostat), the control will first check for indoor fan operation. If the fan is not on, then cooling will not be activated. If the fan is on, then the control will open the EconoMiSer IV damper to the minimum position.

On the initial power to the EconoMiSer IV control, it will take the damper up to 2½ minutes before it begins to position itself. Any change in damper position will take up to 30 seconds to initiate. Damper movement from full closed to full open (or vice versa) will take between 1½ and 2½ minutes.

If free cooling can be used as determined from the appropriate changeover command (switch, dry bulb, enthalpy curve, differential dry bulb, or differential enthalpy), then the control will modulate the dampers open to maintain the mixed air temperature setpoint at 50°F to 55°F (10°C to 13°C).

If there is a further demand for cooling (cooling second stage — Y2 is energized), then the control will bring on compressor stage 1 to maintain the mixed air temperature setpoint. The EconoMiSer IV damper will be open at maximum position. EconoMiSer IV operation is limited to a single compressor.

2-Speed Note: When operating in ventilation mode only, the indoor fan motor will automatically adjust to 66% of the total cfm established.

Heating, unit with EconoMiSer

When the room temperature calls for heat through terminal W1, the indoor (evaporator) fan contactor (IFC) and heater contactor no. 1 (HC1) are energized and the reversing valve(s) de-energize and switches position. On units equipped for 2 stages of heat, when additional heat is needed, heater contactor no. 2 is energized through W2. The economizer damper moves to the minimum position. When the thermostat is satisfied, the damper moves to the fully closed position.

Defrost

When the temperature of the outdoor coil drops below 28°F (−2°C) as sensed by the defrost thermostat (DFT2) and the defrost timer is at the end of a timed period (adjustable at 30, 60, 90 or 120 minutes), reversing valve solenoids (RVS1 and RVS2) are energized and the OFC is de-energized. This switches the position of the reversing valves and shuts off the outdoor fan. The electric heaters (if installed) will be energized.

The unit continues to defrost until the coil temperature as measured by DFT2 reaches 65°F (18°C), or the duration of defrost cycle completes a 10 minute period.

During the Defrost mode, if circuit 1 defrosts first, RVS1 will oscillate between Heating and Cooling modes until the Defrost mode is complete.

At the end of the defrost cycle, the electric heaters (if installed) will be de-energized; the reversing valves switch and the outdoor fan motor will be energized. The unit will now operate in the Heating mode.

If the space thermostat is satisfied during a defrost cycle, the unit will continue in the Defrost mode until the time or temperature constraints are satisfied.

Automatic changeover

When the system selection switch is set at AUTO position, unit automatically changes from heating operation to cooling operation when the temperature of the conditioned space rises to the cooling level setting. When the temperature of the conditioned space falls to the heating level setting, unit automatically changes from cooling to heating operation (with a 3°F dead-band in between).

Continuous air circulation

Turn unit power on. Set system control at OFF position. Set fan switch at ON position. The indoor fan contactor is energized through the thermostat switch and the indoor fan runs continuously.

Emergency heat

When the switch is on (thermostat is set to the EM HT position), compressor circuit and outdoor thermostats are bypassed, and the second stage of thermostat energizes the indoor blower and the electric resistance heaters.

Application data

Min operating ambient temp (cooling)

In mechanical cooling mode, your Bryant rooftop can safely operate down to an outdoor ambient temperature of 25°F (-4°C). It is possible to provide cooling at lower outdoor ambient temperatures by using less outside air, economizers, and/or accessory low ambient kits.

Max operating ambient temp (cooling)

The maximum operating ambient temperature for cooling mode is 115°F (46°C). While cooling operation above 115°F (46°C) may be possible, it could cause either a reduction in performance, reliability, or a protective action by the unit's internal safety devices.

Min and max airflow (cooling mode)

To maintain safe and reliable operation of your rooftop, operate within the cooling airflow limits. Operating above the max may cause blow-off, undesired airflow noise, or airflow related problems with the rooftop unit. Operating below the min may cause problems with coil freeze-up.

Airflow

All units are draw-through in cooling mode.

Outdoor air application strategies

Economizers reduce operating expenses and compressor run time by providing a free source of cooling and a means of ventilation to match application changing needs. In fact, they should be considered for most applications. Also, consider the various economizer control methods and their benefits, as well as sensors required to accomplish your application goals. Please contact your local Bryant representative for assistance.

Motor limits, Brake horsepower (BHP)

Due to Bryant's internal unit design, air path, and specially designed motors, the full horsepower (maximum continuous BHP) band, as listed in this manual, can be used with the utmost confidence. There is no need for extra safety factors, as

Bryant's motors are designed and rigorously tested to use the entire, listed BHP range without either nuisance tripping or premature motor failure.

Sizing a rooftop

Bigger isn't necessarily better. While an air conditioner needs to have enough capacity to meet the load, it doesn't need excess capacity. In fact, having excess capacity typically results in very poor part load performance and humidity control.

Using higher design temperatures than ASHRAE recommends for your location, adding "safety factors" to the calculated load, and rounding up to the next largest unit, are all signs of oversizing air conditioners. Oversizing can cause short-cycling, and short cycling leads to poor humidity control, reduced efficiency, higher utility bills, drastic indoor temperature swings, excessive noise, and increased wear and tear on the air conditioner.

Rather than oversizing an air conditioner, wise contractors and engineers "right-size" or even slightly undersize air conditioners. Correctly sizing an air conditioner controls humidity better; promotes efficiency; reduces utility bills; extends equipment life, and maintains even, comfortable temperatures.

Low ambient applications

When equipped with a Bryant economizer, your rooftop unit can cool your space by bringing in fresh, cool outside air. In fact, when so equipped, accessory low ambient kit may not be necessary. In low ambient conditions, unless the outdoor air is excessively humid or contaminated, economizer-based "free cooling" is the preferred less costly and energy conscious method.

In low ambient applications where outside air might not be desired (such as contaminated or excessively humid outdoor environments), your Bryant rooftop can operate at ambient temperatures down to -20°F (-29°C) using the recommended accessory Motormaster® low ambient controller.

Guide specifications

Note about this specification:

This specification is in the “Masterformat” as published by the Construction Specification Institute. Please feel free to copy this specification directly into your building spec.

Rooftop Packaged Heat Pump

HVAC Guide Specifications

Size Range: 6 to 12.5 Nominal Tons

Part 1 — 23 06 80 Schedules for Decentralized HVAC Equipment

1.01 23 06 80.13 Decentralized Unitary HVAC Equipment Schedule

A. 23 06 80.13.A. Rooftop unit schedule

1. Schedule is per the project specification requirements.

Part 2 — 23 07 16 HVAC Equipment Insulation

2.01 23 07 16.13 Decentralized, Rooftop Units:

A. 23 07 16.13.A. Evaporator fan compartment:

1. Interior cabinet surfaces shall be insulated with a minimum 1/2-in. thick, minimum 1 1/2 lb density, flexible fiberglass insulation bonded with a phenolic binder, neoprene coated on the air side.
2. Insulation and adhesive shall meet NFPA 90A requirements for flame spread and smoke generation.
3. Unit internal insulation linings are manufactured to meet industry requirements for microbial resistance as required as part of UL-181 and ASTM C1071-12, having been evaluated in accordance with the “Mold Growth and Humidity” test in UL 181, and tests for fungi resistance in ASTM C1338 and ASTM G21. Air stream surfaces shall be evaluated in accordance with the “Erosion Test” in UL 181, as part of ASTM C1071.

B. 23 07 16.13.B. Electric heat compartment:

1. Aluminum foil-faced fiberglass insulation shall be used.
2. Insulation and adhesive shall meet NFPA 90A requirements for flame spread and smoke generation.

Part 3 — 23 09 13 Instrumentation and Control Devices for HVAC

3.01 23 09 13.23 Sensors and Transmitters

A. 23 09 13.23.A. Thermostats

1. Thermostat must:
 - a. have capability to energize 2 different stages of cooling, and 2 different stages of heating.
 - b. include capability for occupancy scheduling.

Part 4 — 23 09 23 Direct-digital Control System for HVAC

4.01 23 09 23.13 Decentralized, Rooftop Units:

A. 23 09 23.13.A. RTU Open Multi-protocol, direct digital controller:

1. Shall be ASHRAE 62 compliant.
2. Shall accept 18-30VAC, 50-60Hz, and consumer 15VA or less power.

3. Shall have an operating temperature range from -40°F (-40°C) to 130°F (54°C), 10% - 90% RH (non-condensing).

4. Shall include built-in protocol for BACnet¹ (MS/TP and PTP modes), Modbus² (RTU and ASCII), Johnson N2 and LonWorks. LonWorks Echelon processor required for all Lon applications shall be contained in separate communication board.

5. Shall allow access of up to 62 network variables (SNVT). Shall be compatible with all open controllers.

6. Baud rate controller shall be selectable using a dipswitch.

7. Shall have an LED display independently showing the status of serial communication, running, errors, power, all digital outputs, and all analog inputs.

8. Shall accept the following inputs: space temperature, setpoint adjustment, outdoor air temperature, indoor air quality, outdoor air quality, compressor lock-out, fire shutdown, enthalpy switch, and fan status/filter status/humidity/ remote occupancy.

9. Shall provide the following outputs: economizer, fan, cooling stage 1, cooling stage 2, heat stage 1, heat stage 2, heat stage 3/ exhaust/ reversing valve.

10. Shall have built-in surge protection circuitry through solid state polyswitches. Polyswitches shall be used on incoming power and network connections. Polyswitches will return to normal when the “trip” condition clears.

11. Shall have a battery back-up capable of a minimum of 10,000 hours of data and time clock retention during power outages.

12. Shall have built-in support for Bryant technician tool.

13. Shall include an EIA-485 protocol communication port, an access port for connection of either a computer or a Bryant technician tool, an EIA-485 port for network communication to intelligent space sensors and displays, and a port to connect an optional LonWorks communications card.

14. Software upgrades will be accomplished by either local or remote download. No software upgrades through chip replacements are allowed.

Part 5 — 23 09 33 Electric and Electronic Control System for HVAC

5.01 23 09 33.13 Decentralized, Rooftop Units:

A. 23 09 33.13.A. General:

1. Shall be complete with self-contained low voltage control circuit protected by a resettable circuit breaker on the 24-v transformer side. Transformer shall have 75VA capability.

2. Shall utilize color-coded wiring.

1. BACnet is a registered trademark of ASHRAE (American Society of Heating, Refrigerating and Air-Conditioning Engineers).
2. Modbus is a registered trademark of Schneider Electric.

Guide specifications (cont)

3. Shall include a central control terminal board to conveniently and safely provide connection points for vital control functions such as: smoke detectors, phase monitor, economizer, thermostat, DDC control options, loss of charge, freeze switch, high pressure switches.
 4. Unit shall include a minimum of one 8-pin screw terminal connection board for connection of control wiring.
 5. Shall include integrated defrost system to prevent excessive frost accumulation during heating duty, and shall be controlled as follows:
 - a. Defrost shall be initiated on the basis of time and coil temperature.
 - b. A 30, 60, 90, 120 minute timer shall activate the defrost cycle only if the coil temperature is low enough to indicate a heavy frost condition.
 - c. Defrost cycle shall terminate when defrost thermostat is satisfied and shall have a positive termination time of 10 minutes.
 6. Defrost system shall also include:
 - a. Defrost Cycle Indicator LED.
 - b. Dip switch selectable defrost time between 30, 60, 90 and 120 minutes. Factory set at 30 minutes.
 - c. Molded plug connection to ensure proper connection.
- B. 23 09 33.13.B. Safeties:
1. Compressor overtemperature, overcurrent.
 2. Loss of charge switch:
 - a. Units with 2 compressors shall have different sized connectors for the circuit 1 and circuit 2 low and high pressure switches. They shall physically prevent the cross-wiring of the safety switches between circuits 1 and 2.
 - b. Loss of charge switch shall use different color wire than the high pressure switch. The purpose is to assist the installer and service technician to correctly wire and or troubleshoot the rooftop unit.
 3. High-pressure switch:
 - a. Units with 2 compressors shall have different sized connectors for the circuit 1 and circuit 2 low and high pressure switches. They shall physically prevent the cross-wiring of the safety switches between circuits 1 and 2.
 - b. High pressure switch shall use different color wire than the low pressure switch. The purpose is to assist the installer and service technician to correctly wire and/or troubleshoot the rooftop unit.
 4. Freeze protection thermostat, evaporator coil.
 5. Automatic reset, motor thermal overload protector.

Part 6 — 23 09 93 Sequence of Operations for HVAC Controls

6.01 23 09 93.13 Decentralized, Rooftop Units:

- A. 23 09 93.13.A INSERT SEQUENCE OF OPERATION

Part 7 — 23 40 13 Panel Air Filters

7.01 23 40 13.13 Decentralized, Rooftop Units:

- A. 23 40 13.13.A. Standard filter section
 1. Shall consist of factory-installed, low velocity, throwaway 2-in. thick fiberglass filters of commercially available sizes.
 2. Unit shall use only one filter size. Multiple sizes are not acceptable.
 3. Filters shall be accessible through an access panel with “no-tool” removal as described in the unit cabinet section of this specification (23 81 19.13.G).

Part 8 — 23 81 19 Self-Contained Air Conditioners

8.01 23 81 19.13 Small-Capacity Self-Contained Air Conditioners (548J 07-14)

- A. 23 81 19.13.A. General:

1. Outdoor, rooftop mounted, electrically controlled, heating and cooling unit utilizing a(n) hermetic scroll compressor(s) for cooling duty and heat pump for heating duty.
2. Factory assembled, single piece heating and cooling rooftop unit. Contained within the unit enclosure shall be all factory wiring, piping, controls, and special features required prior to field start-up.
3. Unit shall use Puron® (R-410A) refrigerant.
4. Unit shall be installed in accordance with the manufacturer’s instructions.
5. Unit must be selected and installed in compliance with local, state, and federal codes.

- B. 23 81 19.13.B. Quality Assurance:

1. Unit meets ASHRAE 90.1-2016 and IECC-2015 minimum efficiency requirements.
2. Unit shall be rated in accordance with AHRI Standards 340/360.
3. Unit shall be designed to conform to ASHRAE 15.
4. Unit shall be ETL-tested and certified in accordance with ANSI Z21.47 Standards and ETL-listed and certified under Canadian standards as a total package for safety requirements.
5. Insulation and adhesive shall meet NFPA 90A requirements for flame spread and smoke generation.
6. Unit internal insulation linings shall be resistant to mold growth in accordance with “mold growth and humidity” test in ASTM C1338, G21, and UL 181 or comparable test method. Air stream surfaces shall be evaluated in accordance with the “Erosion Test” in UL 181, as part of ASTM C1071.
7. Unit casing shall be capable of withstanding 500 hour salt spray exposure per ASTM B117 (scribed specimen).

8. Roof curb shall be designed to conform to NRCA Standards.
 9. Unit shall be subjected to a completely automated run test on the assembly line. The data for each unit will be stored at the factory, and must be available upon request.
 10. Unit shall be designed in accordance with UL Standard 1995, ETL listed including tested to withstand rain.
 11. Unit shall be constructed to prevent intrusion of snow and tested to prevent snow intrusion into the control box up to 40 mph.
 12. Unit shake tested to assurance level 1, ASTM D4169 to ensure shipping reliability.
 13. High Efficiency Motors listed shall meet section 313 of the Energy Independence and Security Act of 2007 (EISA 2007).
- C. 23 81 19.13.C. Delivery, Storage, and Handling:
1. Unit shall be stored and handled per manufacturer's recommendations.
 2. Lifted by crane requires either shipping top panel or spreader bars.
 3. Unit shall only be stored or positioned in the upright position.
- D. 23 81 19.13.D. Project Conditions:
As specified in the contract.
- E. 23 81 19.13.E. Operating Characteristics:
1. Unit shall be capable of starting and running at 115°F (46°C) ambient outdoor temperature, meeting maximum load criteria of AHRI Standard 340/360 at ±10% voltage.
 2. Compressor with standard controls shall be capable of operation from 25°F (-4°C), ambient outdoor temperatures. Accessory winter start kit is necessary if mechanically cooling at ambient temperatures below 25°F (-4°C).
 3. Unit shall be capable of simultaneous heating duty and defrost cycle operation when using accessory electric heaters.
 4. Unit shall discharge supply air vertically or horizontally as shown on contract drawings.
 5. Unit shall be factory configured for vertical supply and return configurations.
 6. Unit shall be field convertible from vertical to horizontal configuration.
 7. Unit shall be capable of mixed operation: vertical supply with horizontal return or horizontal supply with vertical return.
- F. 23 81 19.13.F. Electrical Requirements:
Main power supply voltage, phase, and frequency must match those required by the manufacturer.
- G. 23 81 19.13.G. Unit Cabinet:
1. Unit cabinet shall be constructed of galvanized steel, and shall be bonderized and coated with a pre-painted baked enamel finish on all externally exposed surfaces.
 2. Unit cabinet exterior paint shall be: film thickness, (dry) 0.003 inches minimum, gloss (per ASTM D523, 60°F / 16°C): 60, Hardness: H-2H Pencil hardness.
 3. Evaporator fan compartment interior cabinet insulation shall conform to AHRI Standards 340/360 minimum exterior sweat criteria. Interior surfaces shall be insulated with a minimum 1/2-in. thick, 1 lb density, flexible fiberglass insulation, neoprene coated on the air side. Aluminum foil-faced fiberglass insulation shall be used in the heat compartment.
 4. Unit internal insulation linings shall be resistant to mold growth in accordance with "mold growth and humidity" test in ASTM C1338, G21, and UL 181 or comparable test method. Air stream surfaces shall be evaluated in accordance with the "Erosion Test" in UL 181, as part of ASTM C1071.
 5. Base of unit shall have a minimum of three locations for thru-the-base electrical connections (factory-installed or field-installed), standard.
 6. Base Rail:
 - a. Unit shall have base rails on a minimum of 2 sides.
 - b. Holes shall be provided in the base rails for rigging shackles to facilitate maneuvering and overhead rigging.
 - c. Holes shall be provided in the base rail for moving the rooftop by fork truck.
 - d. Base rail shall be a minimum of 16 gage thickness.
 7. Condensate pan and connections:
 - a. Shall be a sloped condensate drain pan made of a non-corrosive material.
 - b. Shall comply with ASHRAE Standard 62.
 - c. Shall use a 3/4-in. -14 NPT drain connection, possible either through the bottom or end of the drain pan. Connection shall be made per manufacturer's recommendations.
 8. Top panel:
 - a. Shall be a single piece top panel on 07 through 09 sizes, two pieces on 12 and 14 sizes.
 9. Electrical Connections:
 - a. All unit power wiring shall enter unit cabinet at a single, factory prepared, knockout location.
 - b. Thru-the-base capability:
 - 1) Standard unit shall have a thru-the-base electrical location(s) using a raised, embossed portion of the unit basepan.
 - 2) Optional, factory-approved, water-tight connection method must be used for thru-the-base electrical connections.
 - 3) No basepan penetration, other than those authorized by the manufacturer, is permitted.
 10. Component access panels (standard):
 - a. Cabinet panels shall be easily removable for servicing.

Guide specifications (cont)

- b. Unit shall have one factory-installed, tool-less, removable, filter access panel.
- c. Panels covering control box, indoor fan, indoor fan motor, gas components (where applicable), and compressors shall have molded composite handles.
- d. Handles shall be UV modified, composite, permanently attached, and recessed into the panel.
- e. Screws on the vertical portion of all removable access panel shall engage into heat resistant, molded composite collars.
- f. Collars shall be removable and easily replaceable using manufacturer recommended parts.

H. 23 81 19.13.H. Coils:

1. Standard Aluminum/Copper Coils:

- a. Standard evaporator and condenser coils shall have aluminum lanced plate fins mechanically bonded to seamless internally grooved copper tubes with all joints brazed.
- b. Evaporator coils shall be leak tested to 150 psig, pressure tested to 450 psig, and qualified to UL 1995 burst test at 1775 psig.
- c. Condenser coils shall be leak tested to 150 psig, pressure tested to 650 psig, and qualified to UL 1995 burst test at 1980 psig.

2. Optional pre-coated aluminum fin condenser coils:

- a. Shall have a durable epoxy-phenolic coating to provide protection in mildly corrosive coastal environments.
- b. Coating shall be applied to the aluminum fin stock prior to the fin stamping process to create an inert barrier between the aluminum fin and copper tube.
- c. Epoxy-phenolic barrier shall minimize galvanic action between dissimilar metals.
- d. Corrosion durability of fin stock shall be confirmed through testing to be no less than 1000 hours salt spray per ASTM B117-90.
- e. Corrosion durability of fin stock shall be confirmed through testing to have no visible corrosion after 48 hour immersion in a room temperature solution of 5% salt, 1% acetic acid.
- f. Fin stock coating shall pass 2000 hours of the following: one week exposure in the prohesion chamber followed by one week of accelerated ultraviolet light testing. Prohesion chamber: the solution shall contain 3.5% sodium chloride and 0.35% ammonium sulfate. The exposure cycle is one hour of salt fog application at ambient followed by one hour drying at 95°F (35°C).

3. Optional copper-fin evaporator and condenser coils on all models:

- a. Shall be constructed of copper fins mechanically bonded to copper tubes and copper tube sheets.

- b. Galvanized steel tube sheets shall not be acceptable.
- c. A polymer strip shall prevent coil assembly from contacting the sheet metal coil pan to minimize potential for galvanic corrosion between coil and pan.

4. Optional E-coated aluminum-fin evaporator and condenser coils on all models:

- a. Shall have a flexible epoxy polymer coating uniformly applied to all coil surface areas without material bridging between fins.
- b. Coating process shall ensure complete coil encapsulation of tubes, fins and headers.
- c. Color shall be high gloss black with gloss per ASTM D523-89.
- d. Uniform dry film thickness from 0.8 to 1.2 mil on all surface areas including fin edges.
- e. Superior hardness characteristics of 2H per ASTM D3363-92A and cross-hatch adhesion of 4B-5B per ASTM D3359-93.
- f. Impact resistance shall be up to 160 in.-lb (ASTM D2794-93).
- g. Humidity and water immersion resistance shall be up to minimum 1000 and 250 hours respectively (ASTM D2247-92 and ASTM D870-92).
- h. Corrosion durability shall be confirmed through testing to be no less than 6000 hours salt spray per ASTM B117-90.

I. 23 81 19.13.I. Refrigerant Components:

1. Refrigerant circuit shall include the following control, safety, and maintenance features:

- a. Fixed orifice metering system shall prevent mal-distribution of two-phase refrigerant by including multiple fixed orifice devices in each refrigeration circuit. Each orifice is to be optimized to the coil circuit it serves.
- b. Refrigerant filter drier.
- c. Service gage connections on suction and discharge lines.
- d. Pressure gage access through a specially designed access port in the top panel of the unit.
- e. Suction line accumulator to provide protection in all operating modes from cooling, heating and reverse cycle switching.

2. There shall be gage line access port in the top of the rooftop, covered by a black, removable plug:

- a. The plug shall be easy to remove and replace.
- b. When the plug is removed, the gage access port shall enable maintenance personnel to route their pressure gage lines.
- c. This gage access port shall facilitate correct and accurate condenser pressure readings by enabling the reading with the compressor access panel on.

- d. The plug shall be made of a leak proof, UV-resistant, composite material.
3. Compressors:
- a. Unit shall use one fully hermetic, scroll compressor for each independent refrigeration circuit.
 - b. Models shall be available with single compressor designs on 07 models, plus additional 2 compressor (stage) models from 08-14 sizes.
 - c. Compressor motors shall be cooled by refrigerant gas passing through motor windings.
 - d. Compressors shall be internally protected from high discharge temperature conditions.
 - e. Compressors shall be protected from an over-temperature and over-amperage conditions by an internal, motor overload device.
 - f. Compressor shall be factory mounted on rubber grommets.
 - g. Compressor motors shall have internal line break thermal, current overload and high pressure differential protection.
 - h. Crankcase heaters shall be utilized on all models to protect compressor with specific refrigerant charge.
- J. 23 81 19.13.J. Filter Section:
- 1. Filters access is specified in the unit cabinet section of this specification.
 - 2. Filters shall be held in place by a pivoting filter tray, facilitating easy removal and installation.
 - 3. Shall consist of factory-installed, low velocity, throw-away 2-in. thick fiberglass filters.
 - 4. Filters shall be standard, commercially available sizes.
 - 5. Only one size filter per unit is allowed.
- K. 23 81 19.13.K. Evaporator Fan and Motor:
- 1. Evaporator fan motor:
 - a. Shall have permanently lubricated bearings.
 - b. Shall have inherent automatic-reset thermal overload protection or circuit breaker.
 - c. Shall have a maximum continuous bhp rating for continuous duty operation; no safety factors above that rating shall be required.
 - 2. Belt-driven Evaporator Fan:
 - a. Belt drive shall include an adjustable pitch motor pulley.
 - b. Shall use sealed, permanently lubricated ball-bearing type.
 - c. Blower fan shall be double inlet type with forward-curved blades.
 - d. Shall be constructed from steel with a finish that aids with corrosion resistance and dynamically balanced.
- L. 23 81 19.13.L. Condenser Fans and Motors:
- 1. Condenser fan motors:
 - a. Shall be a totally enclosed motor.
 - b. Shall use permanently lubricated bearings.
 - c. Shall have inherent thermal overload protection with an automatic reset feature.
 - d. Shall use a shaft down design on all models.
 - 2. Condenser Fans:
 - a. Shall be a direct driven propeller type fan.
 - b. Shall have aluminum blades riveted to steel spiders that have corrosion resistant properties and shall be dynamically balanced.
- M. 23 81 19.13.M. Special Features, Options and Accessories:
- 1. 2-Speed Indoor Fan Motor System for all models:
 - a. Evaporator fan motor:
 - 1) Shall have permanently lubricated bearings.
 - 2) Shall have a maximum continuous bhp rating for continuous duty operation; no safety factors above that rating.
 - 3) Shall be Variable Frequency duty and 2-speed control.
 - 4) Shall contain motor shaft grounding ring to prevent electrical bearing fluting damage by safely diverting harmful shaft voltages and bearing currents to ground.
 - 2. Variable Frequency Drive (VFD). Only available on 2-speed indoor fan motor option:
 - a. Factory-supplied VFDs qualify, through ABB, for a 12-month warranty from date of commissioning or 18 months from date of sale, whichever occurs first.
 - b. Shall be installed inside the unit cabinet, mounted, wired and tested.
 - c. Shall contain Electromagnetic Interference (EMI) frequency protection.
 - d. Insulated Gate Bi-Polar Transistors (IGBT) used to produce the output pulse width modulated (PWM) waveform, allowing for quiet motor operation.
 - e. Self diagnostics with fault and power code LED indicator. Field accessory display kit available for further diagnostics and special setup applications.
 - f. RS485 capability standard.
 - g. Electronic thermal overload protection.
 - h. 5% swinging chokes for harmonic reduction and improved power factor.
 - i. All printed circuit boards shall be conformal coated.
 - 3. Integrated EconoMiSer® IV, EconoMiSer2, and EconoMiSer X low leak rate models, factory or field-installed:
 - a. Integrated, gear driven opposing modulating blade design type capable of simultaneous economizer and compressor operation.
 - b. Independent modules for vertical or horizontal return configuration shall be available. Vertical

Guide specifications (cont)

- return modules shall be available as a factory-installed option.
- c. Damper blades shall be galvanized steel with composite gears. Plastic or composite blades on intake or return shall not be acceptable.
 - d. Shall include all hardware and controls to provide free cooling with outdoor air when temperature and/or humidity are below setpoints.
 - e. Shall be equipped with gear driven dampers for both the outdoor ventilation air and the return air for positive air stream control.
 - f. Standard leak rate models shall be equipped with dampers not to exceed 2% leakage at 1 in. wg pressure differential.
 - g. Economizer controller on EconoMiSer IV models shall be Honeywell W7212 that provides:
 - 1) Combined minimum and DCV maximum damper position potentiometers with compressor staging relay.
 - 2) Functions with solid state analog enthalpy or dry bulb changeover control sensing.
 - 3) Contain LED indicates for: when free cooling is available, when module is in DCV mode, when exhaust fan contact is closed.
 - h. Economizer controller on EconoMiSer X models shall be the Honeywell W7220 that provides:
 - 1) 2-line LCD interface screen for setup, configuration and troubleshooting.
 - 2) On-board Fault Detection and Diagnostics (FDD) that senses and alerts when the economizer is not operating properly, per California Title 24.
 - 3) Sensor failure loss of communication identification.
 - 4) Automatic sensor detection.
 - 5) Capabilities for use with multiple-speed indoor fan systems.
 - 6) Utilize digital sensors: Dry bulb and Enthalpy.
 - i. Economizer controller on EconoMiSer 2 models with RTU Open controller shall be a 4 to 20mA design controlled directly by the RTU Open controller. RTU Open controller meets California Title 24 Fault Detection and Diagnostic (FDD) requirements.
 - j. Shall be capable of introducing up to 100% outdoor air.
 - k. Shall be equipped with a barometric relief damper capable of relieving up to 100% return air and contain seals that meet ASHRAE 90.1-2016 and IECC-2015 requirements.
 - l. Shall be designed to close damper(s) during loss-of-power situations with spring return built into motor.
 - m. Dry bulb outdoor air temperature sensor shall be provided as standard. Enthalpy sensor is also available for factory-installed economizers only. Outdoor air sensor setpoint shall be adjustable and shall range from 40°F to 100°F (4°C to 38°C). Additional sensor options shall be available as accessories.
 - n. The economizer controller shall also provide control of an accessory power exhaust unit function. Factory set at 100%, with a range of 0% to 100%.
 - o. The economizer shall maintain minimum air-flow into the building during occupied period and provide design ventilation rate for full occupancy.
 - p. Dampers shall be completely closed when the unit is in the unoccupied mode.
 - q. Economizer controller shall accept a 2 to 10 Vdc CO₂ sensor input for IAQ/DCV control. In this mode, dampers shall modulate the outdoor air damper to provide ventilation based on the sensor input.
 - r. Compressor lockout temperature on W7220 is adjustable from -45°F to 80°F (-43°C to 27°C), set at a factory default of 32°F (0°C). Others shall open at 35°F (2°C) and close at 50°F (10°C).
 - s. Actuator shall be direct coupled to economizer gear. No linkage arms or control rods shall be acceptable.
 - t. Economizer controller shall provide indications when in free cooling mode, in the DCV mode, or the exhaust fan contact is closed.
4. Integrated EconoMiSer2, and EconoMiSer X Ultra Low Leak rate models, factory or field-installed:
- a. Integrated, gear driven opposing modulating blade design type capable of simultaneous economizer and compressor operation.
 - b. Independent modules for vertical or horizontal return configuration shall be available. Vertical return modules shall be available as a factory-installed option.
 - c. Damper blades shall be galvanized steel with composite gears. Plastic or composite blades on intake or return shall not be acceptable.
 - d. Shall include all hardware and controls to provide free cooling with outdoor air when temperature and/or humidity are below setpoints.
 - e. Shall be equipped with gear driven dampers for both the outdoor ventilation air and the return air for positive air stream control.
 - f. Ultra Low Leak design meets California Title 24 section 140.4 and ASHRAE 90.1-2016 and IECC-2015 requirements for 4 cfm per sq ft on the outside air dampers and 10 cfm per sq ft on the return dampers.
 - g. Economizer controller on EconoMiSer X models shall be the Honeywell W7220 that provides:
 - 1) 2-line LCD interface screen for setup, configuration and troubleshooting.

- 2) On-board Fault Detection and Diagnostics (FDD) that senses and alerts when the economizer is not operating properly, per California Title 24.
 - 3) Sensor failure loss of communication identification.
 - 4) Automatic sensor detection.
 - 5) Capabilities for use with multiple-speed indoor fan systems.
 - 6) Utilize digital sensors: Dry bulb and Enthalpy.
- h. Economizer controller on EconoMi\$er 2 models with RTU Open controller shall be a 4 to 20mA design controlled directly by the RTU Open controller. RTU Open controller meets California Title 24 Fault Detection and Diagnostic (FDD) requirements.
 - i. Shall be capable of introducing up to 100% outdoor air.
 - j. Shall be equipped with a barometric relief damper capable of relieving up to 100% return air and contain seals that meet ASHRAE 90.1-2016 and IECC-2015 requirements.
 - k. Shall be designed to close damper(s) during loss-of-power situations with spring return built into motor.
 - l. Dry bulb outdoor air temperature sensor shall be provided as standard. Enthalpy sensor is also available for factory-installed economizers only. Outdoor air sensor setpoint shall be adjustable and shall range from 40°F to 100°F (4°C to 38°C). Additional sensor options shall be available as accessories.
 - m. The economizer controller shall also provide control of an accessory power exhaust unit function. Factory set at 100%, with a range of 0% to 100%.
 - n. The economizer shall maintain minimum air-flow into the building during occupied period and provide design ventilation rate for full occupancy.
 - o. Dampers shall be completely closed when the unit is in the unoccupied mode.
 - p. Economizer controller shall accept a 2 to 10 Vdc CO₂ sensor input for IAQ/DCV control. In this mode, dampers shall modulate the outdoor air damper to provide ventilation based on the sensor input.
 - q. Compressor lockout temperature on W7220 is adjustable from -45°F to 80°F (-43°C to 27°C), set at a factory default of 32°F (0°C). Others shall open at 35°F (2°C) and close at 50°F (10°C).
 - r. Actuator shall be direct coupled to economizer gear. No linkage arms or control rods shall be acceptable.
- s. Economizer controller shall provide indications when in free cooling mode, in the DCV mode, or the exhaust fan contact is closed.
5. Two-Position Damper (factory-installed):
 - a. Damper shall be a two-position damper. Damper travel shall be from the full closed position to the field adjustable %-open setpoint.
 - b. Damper shall include adjustable damper travel from 25% to 100% (full open).
 - c. Damper shall include single or dual blade, gear driven dampers and actuator motor.
 - d. Actuator shall be direct coupled to damper gear. No linkage arms or control rods shall be acceptable.
 - e. Damper will admit up to 100% outdoor air for applicable rooftop units.
 - f. Damper shall close upon indoor (evaporator) fan shutoff and/or loss of power.
 - g. The damper actuator shall plug into the rooftop unit's wiring harness plug. No hard wiring shall be required.
 - h. Outside air hood shall include aluminum water entrainment filter
 - i. Not available with 2-speed indoor fan motor system models.
6. Head Pressure Control Package (Motormaster®):
 - a. Controller shall control coil head pressure by condenser fan speed modulation or condenser fan cycling and wind baffles.
 - b. Shall consist of solid state control and condenser coil temperature sensor to maintain condensing temperature between 90°F (32°C) and 110°F (43°C) at outdoor ambient temperatures down to -20°F (-29°C).
7. Condenser Coil Hail Guard Assembly:
 - a. Shall protect against damage from hail.
 - b. Shall be louvered design.
8. Unit-Mounted, Non-Fused Disconnect Switch:
 - a. Switch shall be factory-installed, internally mounted.
 - b. National Electric Code (NEC) and UL approved non-fused switch shall provide unit power shutoff.
 - c. Shall be accessible from outside the unit.
 - d. Shall provide local shutdown and lockout capability.
 - e. Sized only for the unit as ordered from the factory. Does not accommodate field-installed devices.
9. Convenience Outlet:
 - a. Powered convenience outlet:
 - 1) Outlet shall be powered from main line power to the rooftop unit.
 - 2) Outlet shall be powered from line side or load side of disconnect by installing

Guide specifications (cont)

- contractor, as required by code. If outlet is powered from load side of disconnect, unit electrical ratings shall be ETL certified and rated for additional outlet amperage.
- 3) Outlet shall be factory-installed and internally mounted with easily accessible 115-v female receptacle.
 - 4) Outlet shall include 15 amp GFI receptacles with independent fuse protection.
 - 5) Voltage required to operate convenience outlet shall be provided by a factory-installed step down transformer.
 - 6) Outlet shall be accessible from outside the unit.
 - 7) Outlet shall include a field-installed "Wet in Use" cover.
- b. Factory-installed non-powered convenience outlet:
- 1) Outlet shall be powered from a separate 115-120v power source.
 - 2) A transformer shall not be included.
 - 3) Outlet shall be factory-installed and internally mounted with easily accessible 115-v female receptacle.
 - 4) Outlet shall include 15 amp GFI receptacles.
 - 5) Outlet shall be accessible from outside the unit.
 - 6) Outlet shall include a field-installed "Wet in Use" cover.
- c. Field-installed non-powered convenience outlet:
- 1) Outlet shall be powered from a separate 115-120v power source.
 - 2) A transformer shall not be included.
 - 3) Outlet shall be field-installed and internally mounted with easily accessible 115-v female receptacle.
 - 4) Outlet shall include 20 amp GFI receptacles. This kit provides a flexible installation method which allows code compliance for height requirements of the GFCI outlet from the finished roof surface as well as the capability to relocate the outlet to a more convenient location.
 - 5) Outlet shall be accessible from outside the unit.
 - 6) Outlet shall include a field-installed "Wet in Use" cover.
10. Thru-the-Base Connectors:
- a. Kits shall provide connectors to permit electrical connections to be brought to the unit through the unit basepan.
 - b. Minimum of three connection locations per unit.
11. Propeller Power Exhaust:
- a. Power exhaust shall be used in conjunction with an integrated economizer.
 - b. Independent modules for vertical or horizontal return configurations shall be available.
 - c. Horizontal power exhaust shall be mounted in return ductwork.
 - d. Power exhaust shall be controlled by economizer controller operation. Exhaust fans shall be energized when dampers open past the 0-100% adjustable setpoint on the economizer control.
12. Roof Curbs (Vertical):
- a. Full perimeter roof curb with exhaust capability providing separate air streams for energy recovery from the exhaust air without supply air contamination.
 - b. Formed galvanized steel with wood nailer strip and shall be capable of supporting entire unit weight.
 - c. Permits installation and securing of ductwork to curb prior to mounting unit on the curb.
13. High Static Indoor Fan Motor(s) and Drive(s):
High static motor(s) and drive(s) shall be factory-installed to provide additional performance range.
14. Thru-the-Bottom Utility Connectors:
Kit shall provide connectors to permit electrical connections to be brought to the unit through the basepan.
15. Outdoor Air Enthalpy Sensor:
The outdoor air enthalpy sensor shall be used to provide single enthalpy control. When used in conjunction with a return air enthalpy sensor, the unit will provide differential enthalpy control. The sensor allows the unit to determine if outside air is suitable for free cooling.
16. Return Air Enthalpy Sensor:
The return air enthalpy sensor shall be used in conjunction with an outdoor air enthalpy sensor to provide differential enthalpy control.
17. Indoor Air Quality (CO₂) Sensor:
- a. Shall be able to provide demand ventilation indoor air quality (IAQ) control.
 - b. The IAQ sensor shall be available in duct mount, wall mount, or wall mount with LED display. The setpoint shall have adjustment capability.
18. Smoke detectors (Factory-Installed Only):
- a. Shall be a four-wire controller and detector.
 - b. Shall be environmental compensated with differential sensing for reliable, stable, and drift-free sensitivity.
 - c. Shall use magnet activated test/reset sensor switches.
 - d. Shall have tool-less connection terminal access.
 - e. Shall have a recessed momentary switch for testing and resetting the detector.
 - f. Controller shall include:
 - 1) One set of normally open alarm initiation contacts for connection to an initiating device circuit on a fire alarm control panel.

- 2) Two Form-C auxiliary alarm relays for interface with rooftop unit or other equipment.
 - 3) One Form-C supervision (trouble) relay to control the operation of the Trouble LED on a remote test/reset station.
 - 4) Capable of direct connection to two individual detector modules.
 - 5) Can be wired to up to 14 other duct smoke detectors for multiple fan shutdown applications.
19. Horn/Strobe Annunciator:
- a. Provides an audible/visual signaling device for use with factory-installed option or field-installed accessory smoke detectors:
 - 1) Requires installation of a field-supplied 24-v transformer suitable for 4.2 VA (AC) or 3.0 VA (DC) per horn/strobe accessory.
 - 2) Requires field-supplied electrical box, North American 1-gang box, 2-in. (51 mm) x 4-in. (102 mm).
 - 3) Shall have a clear colored lens.
20. Winter Start kit:
- a. Shall contain a bypass device around the low-pressure switch.
 - b. Shall be required when mechanical cooling is required down to 25°F (−4°C).
 - c. Shall not be required to operate on an economizer when below an outdoor ambient of 40°F (4°C).
21. Time Guard:
- a. Shall prevent compressor short cycling by providing a 5 minute delay (±2 minutes) before restarting a compressor after shutdown for any reason.
 - b. One device shall be required per compressor.
22. Electric Heat:
- a. Heating Section:
 - 1) Heater element open coil resistance wire, nickel-chrome alloy, 0.29 inches inside diameter, strung through ceramic insulators mounted on metal frame. Coil ends are staked and welded to terminal screw slots.
 - 2) Heater assemblies are provided with integral fusing for protection of internal heater circuits not exceeding 48 amps each. Auto reset thermo limit controls, magnetic heater contactors (24V coil) and terminal block all mounted in electric heater control box (minimum 18 ga galvanized steel) attached to end of heater assembly.
23. Hinged Access Panels:
- a. Shall provide easy access through integrated quarter turn latches.
 - b. Shall be on major panels of: filters, control box, fan motor and compressor.
24. Display Kit for Variable Frequency Drive:
- a. Kit allows the ability to access the VFD controller programs to provide special setup capabilities and diagnostics.
 - b. Kit contains display module and communication cable.
 - c. Display kit can be permanently installed in the unit or used on any 2-speed indoor fan motor system VFD controller as needed.
25. Condensate Overflow Switch:
- a. This sensor and related controller monitors the condensate level in the drain pan and shuts down compression operation when overflow conditions occur. It includes:
 - 1) Indicator light - solid red (more than 10 seconds on water contact - compressors disabled), blinking red (sensor disconnected).
 - 2) 10 second delay to break - eliminates nuisance trips from splashing or waves in pan (sensor needs 10 seconds of constant water contact before tripping).
 - 3) Disables the compressor(s) operation when condensate plug is detected, but still allows fans to run for economizer.
26. Manual Damper:
- Manual Damper package shall consist of damper, air inlet screen, and rain hood which can be preset to admit up to 25 or 50% outdoor air for year-round ventilation. Not available with 2-speed indoor fan motor system models.
27. Supply Duct Cover (14 size only):
- Required when field converting the factory standard vertical duct supply to horizontal duct supply configuration. One required per unit.
28. Disconnect Switch Bracket (14 size only):
- Provides a pre-engineered and sized mounting bracket for applications requiring a unit mounted fused and non-fused disconnect of greater than 100 amps. Bracket assures that no damage will occur to coils when mounting with screws and other fasteners.

