



Turn to the experts

Product Data

WeatherMaker® Single Packaged Heat Pump Rooftop

3 to 6 Nominal Tons

ecoblue™  technology



50FCQ*04, 05, 06, 07

Single-Packaged Heat Pump with Optional Electric Heat
and Puron® Refrigerant (R-410A)

The New Carrier WeatherMaker® packaged heat pump rooftop units (RTU) with EcoBlue™ Technology were designed by customers for customers and integrate new technology to provide value added benefits never seen in this type of equipment before.

New major design features include:

- Patent, industry’s first efficient indoor fan system using Vane Axial fan with electric commutated variable speed motor
- Reliable fixed speed scroll compressor on 3-5 ton sizes and 2 stage scroll technology on 6 ton sizes
- Upgraded unit control board with intuitive indoor fan adjustment
- Reliable copper tube/aluminum fin condenser coil with 5/16-in. tubing to help reduce refrigerant charge versus prior designs
- New outdoor fan system with rugged — lightweight high impact composite fan blade

50FCQ WeatherMaker® units up to 6 tons are specifically designed to fit on Carrier roof curbs that were installed back to 1989, which makes replacement easy and eliminates the need for curb adapters or changing utility connections.

Single-stage units deliver SEERs up to 14.3. IEERs up to 15.0 and heating

HSPFs up to 8.2. All models are capable of either vertical or horizontal airflow.

The Carrier rooftop unit (RTU) was designed by customers for customers. With “no-strip” screw collars, handled access panels, and more, the unit is easy to install, easy to maintain, and easy to use. Precisely sized Suction Line Accumulator to help insure reliable operation at unit operation conditions.

Value-added features include:

- Puron® refrigerant (R-410A)
- single point electrical connections
- optional fully integrated SystemVu™ controls
- RTU Open controller for BACnet¹, LonWorks², Modbus³ and Johnson Controls N2
- 3 to 5 ton models use fixed refrigerant metering devices and 6 ton models use a TXV
- scroll compressors with internal line-break overload protection
- easy access tool-less filter door. Filter track tilts out for filter removal and replacement. All filters are the same size in each unit

Installation ease

All WeatherMaker units are field-convertible to horizontal airflow, which

1. BACnet is a trademark of ASHRAE.
2. LonWorks is a registered trademark of Echelon Corporation.
3. Modbus is a registered trademark of Schneider Electric.

makes it easy to adjust to unexpected job-site complications. Lighter units make for easy replace. Simple, fast plug-in connections to the standard integrated unit control board (UCB). Clearly labeled connections points to reduce installation time. Also, a large control box provides room to work and room to mount Carrier accessory controls.

Easy to maintain

With the new EcoBlue Vane Axial fan system and direct drive ECM motor, there is no longer a need to adjust belts or pulleys as in past designs. This frees up maintenance and installation time.

Easy access handles by Carrier provide quick and easy access to all normally serviced components. Our “no-strip” screw system has superior holding power and guides screws into position while preventing the screw from stripping the unit’s metal.

Sloped, corrosion resistant composite drain pan sheds water; and won’t rust.

Easy to use

The newly re-designed Unit Control Board by Carrier puts all connections and troubleshooting points in one convenient place. Most low voltage connections are made to the same board and make it easy to access it. Setting up the fan is simple by an intuitive switch and rotary dial arrangement. Carrier rooftops have high and low pressure switches, a filter drier, and 2-in. filters standard.

Table of contents

	Page
Features/Benefits	2
Model Number Nomenclature	4
Capacity Ratings	5
Physical Data	7
Options and Accessories	9
Base Unit Dimensions	13
Accessory Dimensions	16
Performance Data	17
Fan Data	29
Electrical Data	58
Typical Wiring Diagrams	81
Sequence of Operation	95
Application Data	97
Guide Specifications	98

EcoBlue™ Technology

Direct drive EcoBlue Technology indoor fan system uses Vane Axial fan design and direct drive electrically commutated motors.

This new Vane Axial design over past belt drive systems has 75% fewer moving parts, uses up to 40% less energy and has no fan belts, blower bearings and shaft.

Streamlined control and integration

Carrier controllers make connecting WeatherMaker® rooftops into existing

building automation systems easy. The units are compatible with conventional thermostat controls, SystemVu™ controls and Carrier RTU Open multi-protocol controller.

Operating efficiency and flexibility

The 50FCQ rooftops meet ASHRAE (American Society of Heating, Refrigerating, and Air-Conditioning Engineers) 90.1-2016, IECC¹-2018 (International

Energy Conservation Code) minimum efficiency requirements.

Field convertible airflow

All WeatherMaker 3 to 6 ton units are field-convertible to horizontal airflow, which makes it easy to adjust to unexpected job-site.

Comfort control

Carrier's Round Tube Plate Fin coil design helps maximize heat transfer and reliable operation.

1. IECC is a registered trademark of the International Code Council, Inc.



50FCQ MODEL NUMBER NOMENCLATURE

Position:	1	2	3	4	5	6	7	8	9	10	11	12	13	14	15	16	17	18
Example:	5	0	F	C	Q	A	0	4	A	2	A	5	-	0	A	0	A	0

Unit Heat Type

50 – Electric Heat Packaged Rooftop

Model Series - WeatherMaker®

FC – 14.3 SEER Standard Efficiency, sizes 04-06
15.0 IEER Standard Efficiency, size 07

Heat Size

Q = Heat Pump

Refrig. Systems Options

A = Standard One Stage Cooling Models (sizes 04-06)
M = Single Circuit, Two Stage Cooling (size 07 only)

Cooling Tons

04 = 3 tons
05 = 4 tons
06 = 5 tons
07 = 6 tons

Sensor Options

A = None
B = Return Air (RA) Smoke Detector
C = Supply Air (SA) Smoke Detector
D = RA + SA Smoke Detector
E = CO₂ Sensor
F = RA Smoke Detector and CO₂ Sensor
G = SA Smoke Detector and CO₂ Sensor
H = RA + SA Smoke Detector and CO₂ Sensor
J = Condensate Overflow Switch
K = Condensate Overflow Switch and RA Smoke Detector
L = Condensate Overflow Switch and RA and SA Smoke Detectors
M = Condensate Overflow Switch and SA Smoke Detector

Indoor Fan Options

1 = Direct Drive – EcoBlue – Standard Static
2 = Direct Drive – EcoBlue – Medium Static
3 = Direct Drive – EcoBlue – High Static

Coil Options – (Outdoor - Indoor - Hail Guard)

A = Al/Cu - Al/Cu
B = Precoat Al/Cu - Al/Cu
C = E-coat Al/Cu - Al/Cu
D = E-coat Al/Cu - E-coat Al/Cu
E = Cu/Cu - Al/Cu
F = Cu/Cu - Cu/Cu
M = Al/Cu - Al/Cu — Louvered Hail Guard
N = Precoat Al/Cu - Al/Cu — Louvered Hail Guard
P = E-coat Al/Cu - Al/Cu — Louvered Hail Guard
Q = E-coat Al/Cu - E-coat Al/Cu — Louvered Hail Guard
R = Cu/Cu - Al/Cu — Louvered Hail Guard
S = Cu/Cu - Cu/Cu — Louvered Hail Guard

Packaging & Seismic Compliance

0 = Standard
1 = LTL

Electrical Options

A = None
C = Non-Fused Disconnect
D = Thru-The-Base Connections
F = Non-Fused Disconnect and Thru-The-Base Connections

Service Options

0 = None
1 = Unpowered Convenience Outlet
2 = Powered Convenience Outlet
3 = Hinged Panels
4 = Hinged Panels and Unpowered Convenience Outlet
5 = Hinged Panels and Powered Convenience Outlet

Intake / Exhaust Options

A = None
B = Temperature Economizer w/ Barometric Relief
F = Enthalpy Economizer w/ Barometric Relief
K = Two-Position Damper (sizes 04-06 only)
U = Temperature Ultra Low Leak Economizer w/ Barometric Relief
W = Enthalpy Ultra Low Leak Economizer w/ Barometric Relief

Base Unit Controls

0 = Electro-mechanical Controls – can be used with field-installed W7212 EconoMiSer® IV (Non-Fault Detection and Diagnostic)
2 = RTU Open Multi-Protocol Controller
3 = SystemVu™ Controls
6 = Electro-mechanical Controls – can be used with W7220 EconoMiSer X (with Fault Detection and Diagnostic)

Design Revision

- = Factory Design Revision

Voltage

1 = 575/3/60
3 = 208-230/1/60
5 = 208-230/3/60
6 = 460/3/60

Note: On single phase (-3 voltage code) models, the following are not available as a factory-installed option:

- Two-Position Damper
- Coated Coils or Cu Fin Coils
- Louvered Hail Guards
- Economizer or 2-Position Damper
- Powered 115 Volt Convenience Outlet

AHRI RATINGS

COOLING MODE

50FCQ	COOLING STAGES	NOM. CAPACITY (tons)	NET COOLING CAPACITY (Btuh)	TOTAL POWER (kW)	SEER	EER	IEER w/ 2-SPEED
A04	1	3	36,200	3.1	14.3	11.8	n/a
A05	1	4	49,500	4.2	14.3	11.8	n/a
A06	1	5	60,500	5.1	14.3	11.8	n/a
M07	2	6	71,000	6.3	n/a	11.2	15.0

HEATING MODE

50FCQ	HSPF	HIGH HEATING CAPACITY (Btuh)	HIGH HEAT COP	LOW HEATING CAPACITY (Btuh)	LOW HEAT COP
A04	8.2	34,000	3.7	17,000	2.25
A05	8.2	46,000	3.7	23,600	2.28
A06	8.2	56,500	3.8	30,000	2.30
M07	n/a	64,500	3.6	35,000	2.40

LEGEND

- AHRI** — Air Conditioning, Heating and Refrigeration Institute
- ASHRAE** — American Society of Heating, Refrigerating and Air Conditioning Engineers
- COP** — Coefficient of Performance
- EER** — Energy Efficiency Ratio
- HSPF** — Heating Seasonal Performance Factor
- IEER** — Integrated Energy Efficiency Ratio
- SEER** — Seasonal Energy Efficiency Ratio

NOTES:

1. Rated and certified under AHRI Standard 210/240 (04-06 size) and 340/360 (07 size).
2. Ratings are based on:
Cooling Standard: 80°F (27°C) db, 67°F (19°C) wb indoor air temperature and 95°F (35°C) db outdoor air temperature.
High Temperature Heating Ratings: 47°F (8°C) db, 43°F (6°C) wb outdoor air temperature and 70°F (21°C) entering indoor coil air.
Low Temperature Heating Ratings: 17°F (-8°C) db, 15°F (-9°C) wb outdoor air temperature and 70°F (21°C) entering indoor coil air.
3. All 50FCQ units comply with ASHRAE 90.1 Energy Standard for minimum SEER and EER requirements.



SOUND RATINGS TABLE

50FCQ UNIT	COOLING STAGES	OUTDOOR SOUND (dB) AT 60 Hz								
		A-WEIGHTED	63	125	250	500	1000	2000	4000	8000
A04	1	75.4	81.8	81.8	77.0	72.6	69.9	64.6	59.3	55.6
A05	1	79.0	85.6	84.7	80.5	76.0	72.4	68.0	62.8	59.3
A06	1	79.0	85.6	84.7	80.5	76.0	72.4	68.0	62.8	59.3
M07	2	79.0	85.6	84.7	80.5	76.0	72.4	68.0	62.8	59.3

LEGEND

dB — Decibel

NOTES:

1. Outdoor sound data is measured in accordance with AHRI.
2. Measurements are expressed in terms of sound power. Do not compare these values to sound pressure values because sound pressure depends on specific environmental factors which normally do not match individual applications. Sound power values are independent of the environment and therefore more accurate.
3. A-weighted sound ratings filter out very high and very low frequencies, to better approximate the response of "average" human ear. A-weighted measurements for Carrier units are taken in accordance with AHRI.

MINIMUM - MAXIMUM AIRFLOW RATINGS (CFM) — COOLING UNITS AND ACCESSORY ELECTRIC HEAT

UNIT	COOLING				ELECTRIC HEAT*	
	MINIMUM AIRFLOW CFM	MINIMUM 2-SPEED AIRFLOW (LOW SPEED)	MINIMUM 2-SPEED AIRFLOW (HIGH SPEED)	MAXIMUM AIRFLOW CFM	MINIMUM AIRFLOW CFM	MAXIMUM AIRFLOW CFM
50FCQA04	900	N/A	N/A	1500	900	1500
50FCQA05	1200	N/A	N/A	2000	1200	2000
50FCQA06	1500	N/A	N/A	2500	1500	2500
50FCQM07	1800	1200	1800	3000	1800	3000

* Electric heat modules are available as field-installed accessories for 50FCQ units.

50FCQ 3 TO 4 TON PHYSICAL DATA

50FCQ UNIT	50FCQA04	50FCQA05
NOMINAL TONS	3	4
BASE UNIT OPERATING WT (lb)*	467	473
REFRIGERATION SYSTEM		
No. Circuits/No. Compressors/Type	1 / 1/ Scroll	1 / 1/ Scroll
Puron® (R-410A) Charge (lbs-oz)	8-0	11-13
Metering Device	Acutrol	Acutrol
High-Pressure Trip/Reset (psig)	630/505	630/505
Low-Pressure Trip/Reset (psig)	54/117	54/117
EVAPORATOR COIL (Indoor)		
Material (Tube/Fin)	Cu/Al	Cu/Al
Coil Type	3/8-in. RTPF	3/8-in. RTPF
Rows/FPI	3/15	3/15
Total Face Area (ft²)	5.5	5.5
Condensate Drain Connection Size	3/4-in.	3/4-in.
CONDENSER COIL (Outdoor)		
Material	Cu/Al	Cu/Al
Coil Type	5/16-in. RTPF	5/16-in. RTPF
Rows/FPI	2/18	2/18
Total Face Area (ft²)	10.7	15.9
EVAPORATOR FAN AND MOTOR (Indoor)		
Standard Static 1 Phase		
Motor Qty/Drive Type	1/Direct	1/Direct
Max Cont BHP	0.44	0.72
RPM Range	189-1890	190-1900
Fan Qty/Type	1/Vane Axial	1/Vane Axial
Fan Diameter (in.)	16.6	16.6
Medium Static 1 Phase		
Motor Qty/Drive Type	1/Direct	1/Direct
Max Cont BHP	0.71	1.06
RPM Range	219-2190	217-2170
Fan Qty/Type	1/Vane Axial	1/Vane Axial
Fan Diameter (in.)	16.6	16.6
High Static 1 Phase		
Motor Qty/Drive Type	1/Direct	1/Direct
Max Cont BHP	1.07	1.53
RPM Range	249-2490	246-2460
Fan Qty/Type	1/Vane Axial	1/Vane Axial
Fan Diameter (in.)	16.6	16.6
Standard Static 3 Phase		
Motor Qty/Drive Type	1/Direct	1/Direct
Max Cont BHP	0.44	0.72
RPM Range	189-1890	190-1900
Fan Qty/Type	1/Vane Axial	1/Vane Axial
Fan Diameter (in.)	16.6	16.6
Medium Static 3 Phase		
Motor Qty/Drive Type	1/Direct	1/Direct
Max Cont BHP	0.71	1.06
RPM Range	219-2190	217-2170
Fan Qty/Type	1/Vane Axial	1/Vane Axial
Fan Diameter (in.)	16.6	16.6
High Static 3 Phase		
Motor Qty/Drive Type	1/Direct	1/Direct
Max Cont BHP	1.07	1.96
RPM Range	249-2490	266-2660
Fan Qty/Type	1/Vane Axial	1/Vane Axial
Fan Diameter (in.)	16.6	16.6
CONDENSER FAN AND MOTOR (Outdoor)		
Qty / Motor Drive Type	1 / Direct	1 / Direct
Motor HP/RPM	1/4 / 1100	1/4 / 1100
Fan Diameter (in.)	23	23
FILTERS		
RA Filter Qty / Size (in.)	2 / 16x25x2	2 / 16x25x2
OA Inlet Screen Qty / Size (in.)	1 / 20x24x1	1 / 20x24x1

* Base unit operating weight does not include weight of options.

50FCQ 5 TO 6 TON PHYSICAL DATA

50FCQ UNIT	50FCQA06	50FCQM07
NOMINAL TONS	5	6
BASE UNIT OPERATING WT (lb)*	584	589
REFRIGERATION SYSTEM		
No. Circuits/No. Compressors/Type	1 / 1 / Scroll	1 / 1 / 2-Stage Scroll
Puron® (R-410A) Charge (lbs-oz)	14-13	16-0
Metering Device	Acutrol	TXV
High-Pressure Trip/Reset (psig)	630/505	630/505
Low-Pressure Trip/Reset (psig)	54/117	54/117
EVAPORATOR COIL (Indoor)		
Material (Tube/Fin)	Cu/Al	Cu/Al
Coil Type	3/8-in. RTPF	3/8-in. RTPF
Rows/FPI	4/15	4/15
Total Face Area (ft²)	7.3	7.3
Condensate Drain Connection Size	3/4-in.	3/4-in.
CONDENSER COIL (Outdoor)		
Material	Cu/Al	Cu/Al
Coil Type	5/16-in. RTPF	5/16-in. RTPF
Rows/FPI	2/18	2/18
Total Face Area (ft²)	18.8	20.5
EVAPORATOR FAN AND MOTOR (Indoor)		
Standard Static 1 Phase		
Motor Qty/Drive Type	1/Direct	—
Max Cont BHP	1.06	—
RPM Range	215-2150	—
Fan Qty/Type	1/Vane Axial	—
Fan Diameter (in.)	16.6	—
Medium Static 1 Phase		
Motor Qty/Drive Type	1/Direct	—
Max Cont BHP	1.44	—
RPM Range	239-2390	—
Fan Qty/Type	1/Vane Axial	—
Fan Diameter (in.)	16.6	—
High Static 1 Phase		
Motor Qty/Drive Type	1/Direct	—
Max Cont BHP	1.96	—
RPM Range	266-2660	—
Fan Qty/Type	1/Vane Axial	—
Fan Diameter (in.)	16.6	—
Standard Static 3 Phase		
Motor Qty/Drive Type	1/Direct	1/Direct
Max Cont BHP	1.06	1.31
RPM Range	215-2150	230-2300
Fan Qty/Type	1/Vane Axial	1/Vane Axial
Fan Diameter (in.)	16.6	16.6
Medium Static 3 Phase		
Motor Qty/Drive Type	1/Direct	1/Direct
Max Cont BHP	1.44	1.76
RPM Range	239-2390	253-2530
Fan Qty/Type	1/Vane Axial	1/Vane Axial
Fan Diameter (in.)	16.6	16.6
High Static 3 Phase		
Motor Qty/Drive Type	1/Direct	1/Direct
Max Cont BHP	2.43	2.43
RPM Range	284-2836	284-2836
Fan Qty/Type	1/Vane Axial	1/Vane Axial
Fan Diameter (in.)	16.6	16.6
CONDENSER FAN AND MOTOR (Outdoor)		
Qty / Motor Drive Type	1 / Direct	1 / Direct
Motor HP/RPM	1/4 / 1100	1/4 / 1100
Fan Diameter (in.)	23	23
FILTERS		
RA Filter Qty / Size (in.)	4 / 16x16x2	4 / 16x16x2
OA Inlet Screen Qty / Size (in.)	1 / 20x24x1	1 / 20x24x1

LEGEND

BHP — Break Horsepower
FPI — Fins Per Inch
OA — Outdoor Air
RA — Return Air

* Base unit operating weight does not include weight of options.

Options and accessories



ITEM	OPTION*	ACCESSORY†
ELECTRIC HEAT		
Electric Resistance Heaters		X
Single Point Kits		X
CABINET		
Thru-the-Base electrical connections	X	X
Hinged Access Panels	X	
MERV-8 Filters	X	
COIL OPTIONS		
Cu/Cu indoor and/or outdoor coils ¹	X	
Pre-coated outdoor coils ¹	X	
Premium, E-coated outdoor coils ¹	X	
CONDENSER PROTECTION		
Condenser coil hail guard (louvered design) ¹	X	X
CONTROLS		
Thermostats, temperature sensors, and subbases		X
SystemVu™ DDC communicating controller	X	
RTU Open Multi-Protocol controller	X	
Smoke detector (supply and/or return air)	X	X
Horn Strobe Annunciator ²		X
Time Guard II compressor delay control circuit		X
Phase Monitor ¹	X	X
Condensate Overflow switch	X	X
ECONOMIZERS AND OUTDOOR AIR DAMPERS		
EconoMiSer® IV for electro-mechanical controls - Non FDD (Standard air leak damper models) ^{1, 3, 9}	X	X
EconoMiSer2 for DDC controls (Standard and Ultra Low Leak air damper models) ^{1, 4}	X	X
EconoMiSer X for electro-mechanical controls, complies with FDD (Standard and Ultra Low Leak damper models) ^{1, 3, 9}	X	X
Motorized 2-position outdoor-air damper ¹	X	X
Manual outdoor-air damper (25% and 50%)		X
Barometric relief ⁵	X	X
Power exhaust - prop design		X

ITEM	OPTION*	ACCESSORY†
ECONOMIZER SENSORS AND IAQ DEVICES		
Single dry bulb temperature sensors ⁶	X	X
Differential dry bulb temperature sensors ⁶		X
Single enthalpy sensors ⁶	X	X
Differential enthalpy sensors ⁶		X
CO ₂ sensor (wall, duct, or unit mounted) ⁶	X	X
INDOOR MOTOR AND DRIVE		
Multiple motor and drive packages	X	
LOW AMBIENT CONTROL		
Winter start kit ⁷		X
Low Ambient controller to -20°F (-29°C) ⁷		X
POWER OPTIONS		
Convenience outlet (powered) ¹	X	
Convenience outlet (unpowered)	X	
Non-fused disconnect ⁸	X	
ROOF CURBS		
Roof curb 14-in. (356 mm)		X
Roof curb 24-in. (610 mm)		X

* Factory-installed option.

† Field-installed accessory.

NOTES:

- Not available on single phase (-3 voltage code) models. Use field-installed accessory where available.
- Requires a field-supplied 24V transformer for each application. See price pages for details.
- FDD (Fault Detection and Diagnostic) capability per California Title 24 section 120.2.
- Models with SystemVu and RTU Open DDC controls comply with California Title 24 Fault Detection and Diagnostic (FDD).
- Included with economizer.
- Sensors used to optimize economizer performance.
- See application data for assistance.
- Non-fused disconnect switch cannot be used when unit electrical rating exceeds:
208-230/1/60 and 208-230/3/60 = 80 amps (FLA).
480/3/60 and 575/3/60 = 80 amps (FLA).
Carrier RTUBuilder automatically selects the amp limitations.
- Available as a factory-installed option for 04-06 models only.

Factory-installed options

Economizer (dry-bulb or enthalpy)

Economizers save money. They bring in fresh, outside air for ventilation; and provide cool outside air to cool your building. This is the preferred method of low-ambient cooling. When coupled to CO₂ sensors, economizers can provide even more savings by coupling the ventilation air to only that amount required.

Economizers are available, installed and tested by the factory, with either enthalpy or dry-bulb temperature inputs. Additional sensors are available as accessories to optimize the economizers. Economizers include a powered exhaust system to help equalize building pressures.

Economizers include gravity controlled barometric relief that helps equalize building pressure and ambient air pressures. This can be a cost effective solution to prevent building pressurization. Economizers are available in Ultra Low Leak and standard low leak versions. Economizers can be factory-installed or easily field-installed.

Unit mounted CO₂ sensor

The CO₂ sensor works with the economizer to intake only the correct amount of outside air for ventilation. As occupants fill your building, the CO₂ sensor detects their presence through increasing CO₂ levels, and opens the economizer appropriately. When the occupants leave, the CO₂ levels decrease, and the sensor appropriately closes the economizer. This intelligent control of the ventilation air, called demand controlled ventilation (DCV), reduces the overall load on the rooftop, saving money. It is also available as a field-installed accessory.

Smoke detector (supply and/or return air)

Trust the experts. Smoke detectors make your application safer and your job easier. Carrier smoke detectors immediately shut down the rooftop unit when smoke is detected. They are available, installed by the factory, for supply air, return air, or both.

Thru-the-base connections

Thru-the-base connections, available as a factory option, are necessary to ensure proper connection and seal when routing wire and piping through the rooftop's basepan and curb. These couplings eliminate roof penetration and should be considered for main power lines, as well as control power.

Hinged access panels

Allows access to unit's major components with specifically designed hinged access panels. Panels are filter, control box access indoor fan motor access.

Cu/Cu (indoor) coils

Copper fins and copper tubes are mechanically bonded to copper tubes and copper tube sheets. A polymer strip prevents coil assembly from contacting the sheet metal coil pan to minimize potential for galvanic corrosion between coil and pan.

E-coated (outdoor and indoor) coils

A flexible epoxy polymer coating uniformly applied to all coil surface areas without material bridging between fins. Coating process shall ensure complete coil encapsulation of tubes, fins and headers.

Pre-coated outdoor coils

A durable epoxy-phenolic coating to provide protection in mildly corrosive coastal environments. The coating minimizes galvanic action between dissimilar metals. Coating is applied to the aluminum fin stock prior to the fin stamping process to create an inert barrier between the aluminum fin and copper tube.

Condenser coil hail guard

Sleek, louvered panels protect the condenser coil from hail damage, foreign objects, and incidental contact.

Single enthalpy sensor

Prevents the wheel from rotating if the outside air conditions are acceptable for free cooling. Both exhaust and supply blowers will remain on.

Convenience outlet (powered or un-powered)

Reduce service and/or installation costs by including a convenience outlet in your specification. Carrier will install this service feature at our factory. Provides a convenient, 15 amp, 115v GFCI receptacle with "Wet in Use" cover. The "powered" option allows the installer to power the outlet from the line side of the disconnect or load side as required by code. The "unpowered" option is to be powered from a separate 115/120v power source.

The unpowered convenience outlet is available as a 15 amp factory-installed option or a 20 amp field-installed accessory.

Non-fused disconnect

This OSHA-compliant, factory-installed, safety switch allows a service technician to locally secure power to the rooftop. When selecting a factory-installed non-fused disconnect, note they are sized for the unit as ordered from the factory. The sizing of these do not accommodate field-installed items such as power exhaust devices, etc. If field installing electric heat with factory-installed non-fused disconnect switch, a single point kit may or may not be required.

SystemVu™ controller

Carrier's SystemVu controller is an optional factory-installed and tested controller.

This controller takes on a whole new approach to provide an intuitive, intelligent controller that not only monitors and controls the unit, but also provides linkage to multiple building automation systems.

Each SystemVu controller makes it easy to set up, service, troubleshoot, gain historical data, generate reports and provide comfort only Carrier is noted for.

Key features include:

- Easy to read back lit four line text screen for superior visibility.
- Quick operational condition LEDs of: Run, Alert, and Fault.
- Simple navigation with large keypad buttons of: Navigation arrows, Test, Back, Enter and Menu.
- Capable of being controlled with a conventional thermostat, space sensor or build automation system.
- Service capabilities include:
 - Auto run test
 - Manual run test
 - Component run hours and starts
 - Commissioning reports
 - Data logging

- Full range of diagnosis:
 - Read refrigerant pressures without the need of gages
 - Sensor faults
 - Compressor reverse rotation
 - Economizer diagnostics that meet California Title 24 requirements
- Quick data transfer via USB port:
 - Unit configuration uploading/downloading
 - Data logging
 - Software upgrades
- Built in capacity for:
 - i-Vu® open systems
 - BACnet systems
 - CCN systems
- Configuration and alarm point capability:
 - Contain over 100 alarm codes
 - Contain over 260 status, troubleshooting, diagnostic and maintenance points
 - Contain over 270 control configuration setpoints

RTU Open, multi-protocol controller

Connect the rooftop to an existing BAS (building automation system) without needing complicated translators or adapter modules using the RTU Open controller. The RTU Open controller speaks the 4 most common building automation system languages (BACnet, Modbus, Johnson Controls N2, and LonWorks). Use this controller when you have an existing BAS. Besides the 4 protocols, it also communicates with a Carrier Open system (i-Vu and VVT®).

Condensate overflow switch

This sensor and related controller monitors the condensate level in the drain pan and shuts down compression operation when overflow conditions occur. It includes:

- Indicator light – solid red (more than 10 seconds on water contact – compressors disabled), blinking red (sensor disconnected)
- 10-second delay to break – eliminates nuisance trips from splashing or waves in pan (sensor needs 10 seconds of constant water contact before tripping)
- Disables the compressor(s) operation when condensate plug is detected, but still allows fans to run for economizer.

Power exhaust with barometric relief

Superior internal building pressure control. This field-installed accessory may eliminate the need for costly, external pressure control fans.

MERV-8 return air filters

This factory option upgrades the return air filters from standard unit filters to high efficiency MERV-8 filters. Non-woven MERV-8 filter media with high strength, moisture-resistant frame. Filter media is securely fastened inside the filter frame on all four sides.

Field-installed accessories

Condenser coil hail guard

Sleek, louvered panels protect the condenser coil from hail damage, foreign objects, and incidental contact. This can be purchased as a factory-installed option or as a field-installed accessory.

Differential enthalpy sensor

The differential enthalpy sensor is comprised of an outdoor and return air enthalpy sensors to provide differential enthalpy control. The sensor allows the unit to determine if outside air is suitable for free cooling.

Wall or duct mounted CO₂ sensor

The IAQ sensor shall be available in duct or wall mount. The sensor provides demand ventilation indoor air quality (IAQ) control.

Phase monitor protection

The Phase Monitor Control will monitor the sequence of three phase electrical system to provide a phase reversal protection; and monitor the three phase voltage inputs to provide a phase loss protection for the three phase device. It will work on either a Delta or Wye power connection.

Winter start kit

The winter start kit by Carrier extends the low ambient limit of your rooftop to 25°F (−4°C). The kit bypasses the low pressure switch, preventing nuisance tripping of the low pressure switch. Other low ambient precautions may still be prudent.

Low ambient controller

The low ambient controller is a head pressure controller kit that is designed to maintain the unit's condenser head pressure during periods of low ambient cooling operation. This device should be used as an alternative to economizer free cooling when economizer usage is either not appropriate or desired. The low ambient controller will either cycle the outdoor fan motors or operate them at reduced speed to maintain the unit operation, depending on the model. This controller allows cooling operation down to −20°F (−29°C) ambient conditions.

Roof curb (14-in./356 mm or 24-in./610 mm)

Full perimeter roof curb with exhaust capability provides separate air streams for energy recovery from the exhaust air without supply air contamination.

Fan/filter status switch

Monitors static pressure across supply and exhaust filters and provides indication when filters become clogged.

Power exhaust

Superior internal building pressure control. This field-installed accessory may eliminate the need for costly, external pressure control fans.

Manual OA damper

Manual outdoor air dampers are an economical way to bring in ventilation air. The dampers are available in 25% and 50% versions.

NOTE: See application tip “ROOFTOP-18-01” prior to use of this damper on 07 size models.

Motorized 2-position damper

The Carrier 2-position, motorized outdoor air damper admits up to 100% outside air. Using reliable, gear-driven technology, the 2-position damper opens to allow ventilation air and closes when the rooftop stops, stopping unwanted infiltration.

NOTE: See application tip “ROOFTOP-18-01” prior to use of this damper on 07 size models.

Options and accessories (cont)



Electric heaters and single point kits

Carrier offers a full-line of field-installed accessory heaters. The heaters are very easy to use, install and are all pre-engineered and certified.

Time Guard II control circuit

This accessory protects your compressor by preventing short-cycling in the event of some other failure, prevents the compressor from restarting for 30 seconds after stopping. Not required with SystemVu™ controller, RTU Open controller, or authorized commercial thermostats.

OPTIONS AND ACCESSORY WEIGHTS

OPTION / ACCESSORY NAME	50FCQ UNIT WEIGHT							
	04		05		06		07	
	lb	kg	lb	kg	lb	kg	lb	kg
Power Exhaust - Vertical	51	23	51	23	51	23	51	23
Power Exhaust - Horizontal	39	18	39	18	39	18	39	18
EconoMi\$er® (X, IV or 2)	35	16	35	16	35	16	35	16
2-Position Damper	39	18	39	18	39	18	58	26
Manual Damper	12	5	12	5	12	5	18	8
Hail Guard (louvered)	13	6	13	6	13	6	17	8
Cu/Cu Condenser Coil	37	17	74	34	74	34	95	43
Cu/Cu Condenser and Evaporator Coils	75	34	112	51	112	51	165	75
Roof Curb (14-in. curb)	95	43	95	43	95	43	95	43
Roof Curb (24-in. curb)	150	68	150	68	150	68	150	68
CO ₂ Sensor	2	1	2	1	2	1	2	1
Optional Indoor Motor/Drive	10	5	10	5	10	5	15	7
Low Ambient Controller	9	4	9	4	9	4	9	4
Winter Start Kit	5	2	5	2	5	2	5	2
Return Air Smoke Detector	7	3	7	3	7	3	7	3
Supply Air Smoke Detector	7	3	7	3	7	3	7	3
Fan Filter Switch	2	1	2	1	2	1	2	1
Non-Fused Disconnect	15	7	15	7	15	7	15	7
Powered Convenience Outlet	36	16	36	16	36	16	36	16
Unpowered Convenience Outlet	4	2	4	2	4	2	4	2
Enthalpy Sensor	2	1	2	1	2	1	2	1
Differential Enthalpy Sensor	3	1	3	1	3	1	3	1

NOTE: Where multiple variations are available, the heaviest combination is listed.

50FCQ*04-07 BASE UNIT DIMENSIONS

- NOTES:
- DIMENSIONS ARE IN INCHES, DIMENSIONS IN [] ARE IN MILLIMETERS.
 - CENTER OF GRAVITY
 - DIRECTION OF AIR FLOW
 - ALL VIEW DRAWN USING 3RD ANGLE

UNIT	J	K
50FCQ*04	33 3/8 [847]	7 7/8 [200]
50FCQ*05	33 3/8 [847]	14 7/8 [377]
50FCQ*06	41 3/8 [1051]	18 5/8 [472]
50FCQ*07	41 3/8 [1051]	18 5/8 [472]



THIS DOCUMENT IS THE PROPERTY OF UTC CLIMATE, CONTROLS & SECURITY AND IS DELIVERED UPON THE EXPRESS CONDITION THAT THE CONTENTS WILL NOT BE DISCLOSED OR USED WITHOUT WRITTEN CONSENT.

SUBMISSION OF THESE DRAWINGS OR DOCUMENTS DOES NOT CONSTITUTE PART PERFORMANCE OR ACCEPTANCE OF CONTRACT.

CONNECTION SIZES	
A	1 3/8" [35] DIA. FIELD POWER SUPPLY HOLE
B	2" [51] DIA. POWER SUPPLY KNOCKOUT
C	1 3/4" [44] DIA. GAUGE ACCESS PLUG
D	7/8" [22] DIA. FIELD CONTROL WIRING HOLE
E	3/4"-14 NPT CONDENSATE DRAIN
G	2 1/2" [64] DIA. POWER SUPPLY KNOCK-OUT

THRU-THE-BASE CHART THESE HOLES REQUIRED FOR USE CRBTMPW008A00, 009A00		
THREADED CONDUIT SIZE	WIRE USE	REQ'D HOLE SIZES (MAX.)
W	1/2"	115W 7/8" [22.2]
X	1/2"	24V 7/8" [22.2]
Y*	3/4"	POWER 1 1/8" [28.6]
**	(009A00) 1/2" FPT GAS	1 1/8" [28.6]
FOR "THRU-THE-BASEPAN" FACTORY OPTION, FITTINGS FOR ONLY X, Y, & Z ARE PROVIDED		
* SELECT EITHER 3/4" OR 1/2" FOR POWER, DEPENDING ON WIRE SIZE		
** (008A00) PROVIDES 3/4" FPT THRU CURB FLANGE & FITTING.		

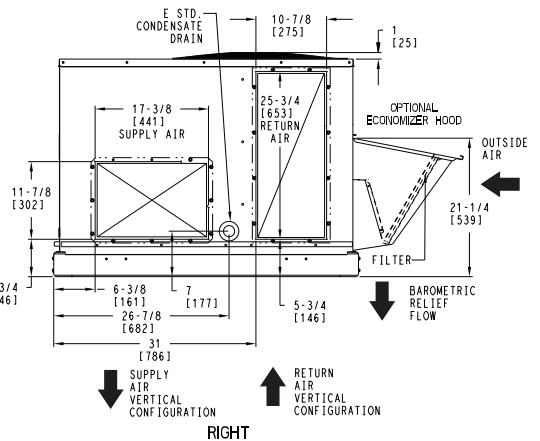
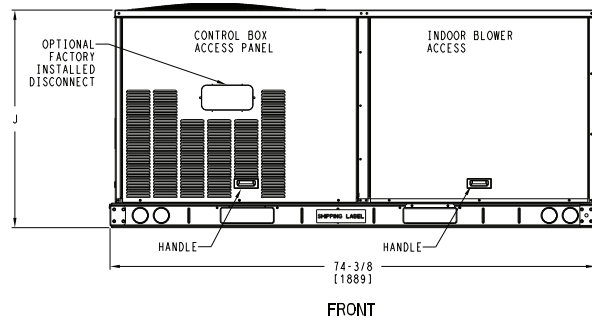
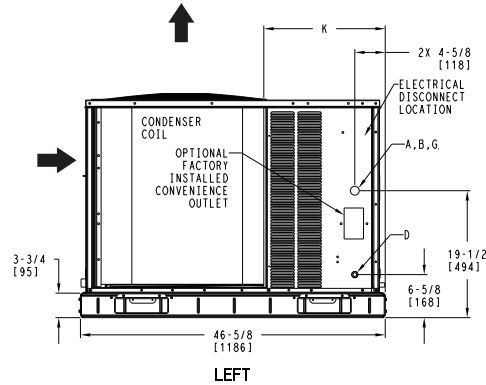
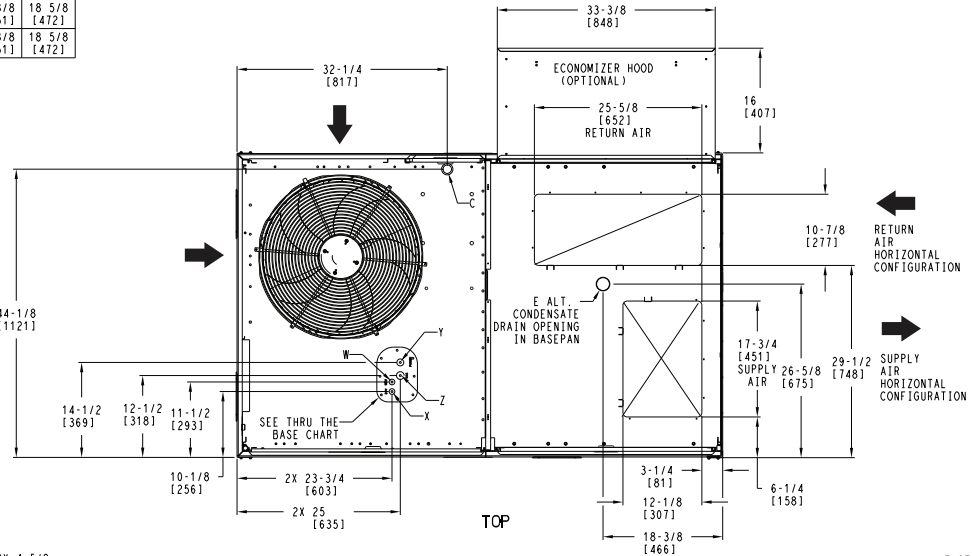

ITC CLASSIFICATION	SHEET	DATE	SUPERCEDES	50FCQ 04-07 SINGLE PACKAGE HEAT PUMP	48TC003348	REV
U.S. ECCN:NSR	1 OF 3	08/15/19	-			-



50FCQ*04-07 BASE UNIT DIMENSIONS (cont)

UNIT	STD. UNIT WEIGHT*		CORNER WEIGHT (A)		CORNER WEIGHT (B)		CORNER WEIGHT (C)		CORNER WEIGHT (D)		C. G.			HEIGHT
	LBS.	KG.	LBS.	KG.	LBS.	KG.	LBS.	KG.	LBS.	KG.	X	Y	Z	
50FCQ*04	467	212	126	57	118	53	108	49	115	52	36 [914]	22 3/8 [568]	16 1/8 [410]	
50FCQ*05	473	215	127	58	119	54	110	50	117	53	36 [914]	22 3/8 [568]	16 1/8 [410]	
50FCQ*06	584	265	160	72	145	66	133	60	146	66	35 3/8 [898]	22 5/16 [557]	16 1/2 [419]	
50FCQ*07	589	267	161	73	146	66	134	61	147	67	35 3/8 [898]	22 5/16 [557]	16 1/2 [419]	

* STANDARD UNIT WEIGHT IS WITHOUT ELECTRIC HEAT AND WITHOUT PACKAGING. FOR OTHER OPTIONS AND ACCESSORIES, REFER TO THE PRODUCT DATA CATALOG.

Carrier THIS DOCUMENT IS THE PROPERTY OF UTC CLIMATE, CONTROLS & SECURITY AND IS DELIVERED UPON THE EXPRESS CONDITION THAT THE CONTENTS WILL NOT BE DISCLOSED OR USED WITHOUT WRITTEN CONSENT. SUBMISSION OF THESE DRAWINGS OR DOCUMENTS DOES NOT CONSTITUTE PART PERFORMANCE OR ACCEPTANCE OF CONTRACT.

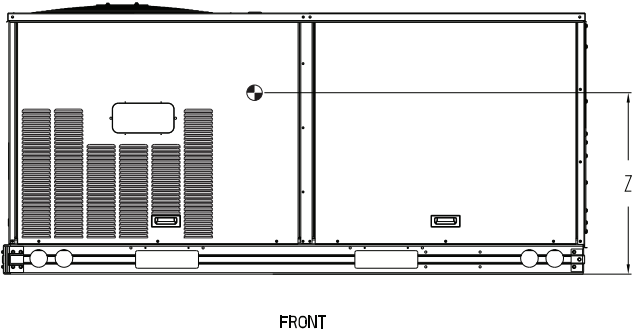
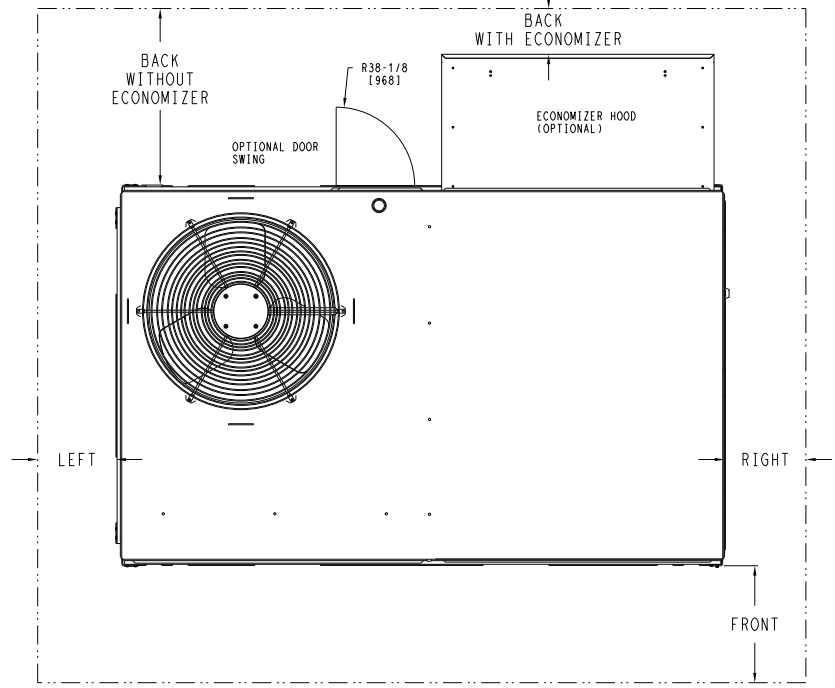
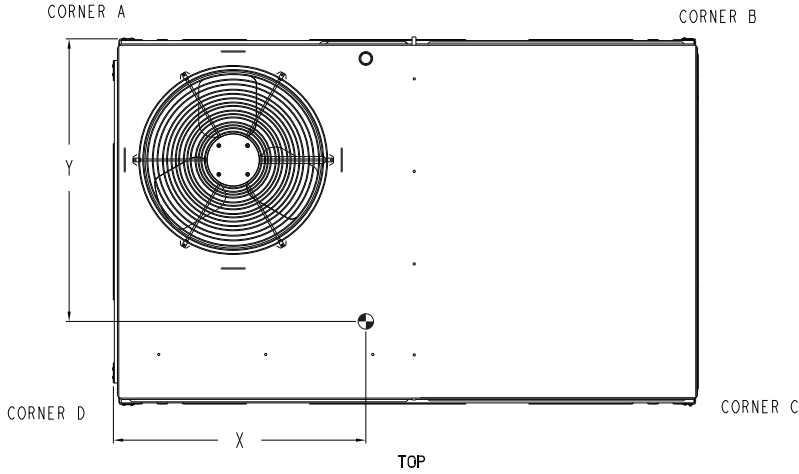

NOTE:
1. FOR ALL MINIMUM CLEARANCES LOCAL CODES OR JURISDICTIONS MAY PREVAIL.

SURFACE	CLEARANCE		OPERATING CLEARANCE
	SERVICE WITH: CONDUCTIVE BARRIER	SERVICE WITH: NONCONDUCTIVE BARRIER	
FRONT	48 [1219mm]	36 [914mm]	18 [457mm]
LEFT	48 [1219mm]	42 [1067mm]	18 [457mm]
BACK W/O ECON	48 [1219mm]	42 [1067mm]	18 [457mm]
BACK W/ECON	36 [914mm]	36 [914mm]	18 [457mm]
RIGHT	36 [914mm]	36 [914mm]	18 [457mm]
TOP	72 [1829mm]	72 [1829mm]	72 [1829mm]

ITC CLASSIFICATION	SHEET	DATE	SUPERCEDES	50FCQ 04-07 SINGLE PACKAGE HEAT PUMP	48TC003348	REV
U.S. ECCN:NSR	2 OF 3	08/15/19	-			-



50FCQ*04-07 BASE UNIT DIMENSIONS (cont)

Carrier UNITED TECHNOLOGIES
 THIS DOCUMENT IS THE PROPERTY OF UTC CLIMATE CONTROLS & SECURITY AND IS DELIVERED UPON THE EXPRESS CONDITION THAT THE CONTENTS WILL NOT BE DISCLOSED OR USED WITHOUT WRITTEN CONSENT.
 SUBMISSION OF THESE DRAWINGS OR DOCUMENTS DOES NOT CONSTITUTE PART PERFORMANCE OR ACCEPTANCE OF CONTRACT.

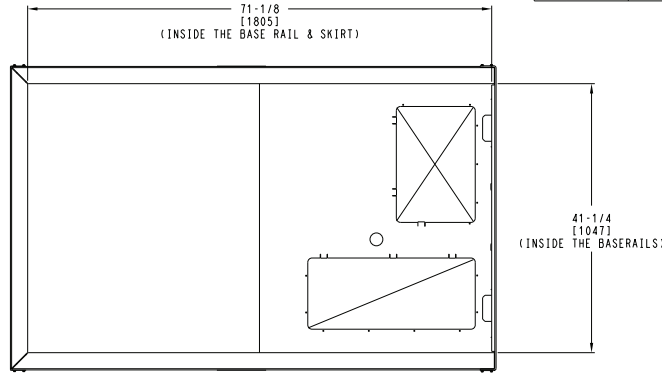
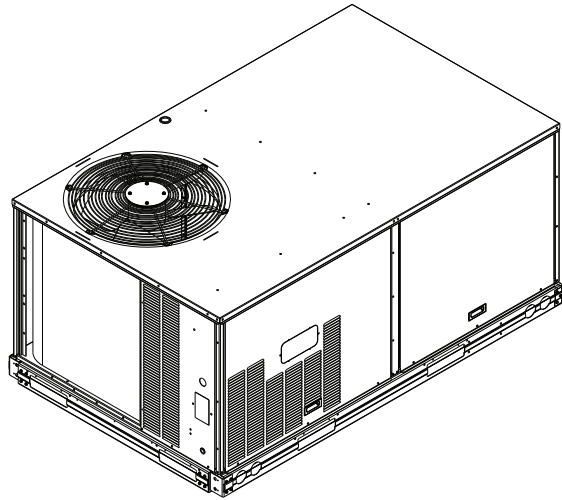

INSIDE BASERAIL DIMENSIONS
 BOTTOM

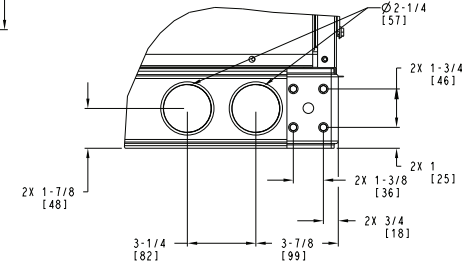

DETAIL C
 TYP 4 PLCS

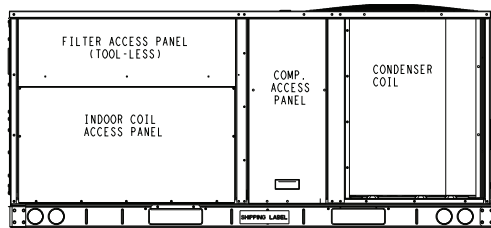

BACK

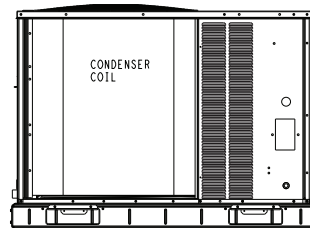

LEFT

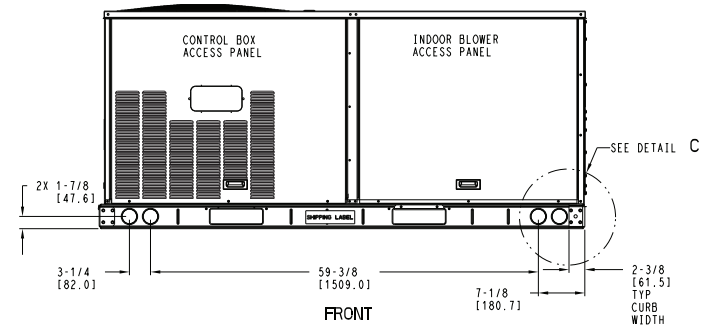

FRONT

ITC CLASSIFICATION	SHEET	DATE	SUPERCEDES	50FCQ 04-07 SINGLE PACKAGE HEAT PUMP	48TC003348	REV
U.S. ECCN:NSR	3 OF 3	08/15/19	-			-



ROOF CURB DIMENSIONS — 50FCQ 04-07

ROOF CURB ACCESSORY #	A
CRRFCURB001A01	14" [356]
CRRFCURB002A01	24" [610]

- NOTES:
1. ROOFCURB ACCESSORY IS SHIPPED DISASSEMBLED.
 2. INSULATED PANELS: 25.4 [1"] THK. POLYURETHANE FOAM, 44.5 [1-3/4"] # DENSITY.
 3. DIMENSIONS IN [] ARE IN MILLIMETERS.
 4. ROOFCURB: 18 GAGE STEEL.
 5. ATTACH DUCTWORK TO CURB. (FLANGES OF DUCT REST ON CURB).
 6. SERVICE CLEARANCE 4 FEET ON EACH SIDE.
 7. DIRECTION OF AIR FLOW.
 8. CONNECTOR PACKAGE CRBTMPWR001A01 IS FOR THRU-THE-CURB GAS TYPE PACKAGE CRBTMPWR003A01 IS FOR THRU-THE-BOTTOM TYPE GAS CONNECTIONS.

CONNECTOR PKG. ACC.	GAS CONNECTION TYPE	GAS FITTING	POWER WIRING FITTING	CONTROL WIRING FITTING	ACCESSORY CONVENIENCE OUTLET WIRING CONNECTOR
CRBTMPWR001A01	THRU THE CURB	3/4" [19] NPT	3/4" [19] NPT	1/2" [12.7] NPT	1/2" [12.7] NPT
CRBTMPWR003A01	THRU THE BOTTOM	1/2" [12.7] NPT			

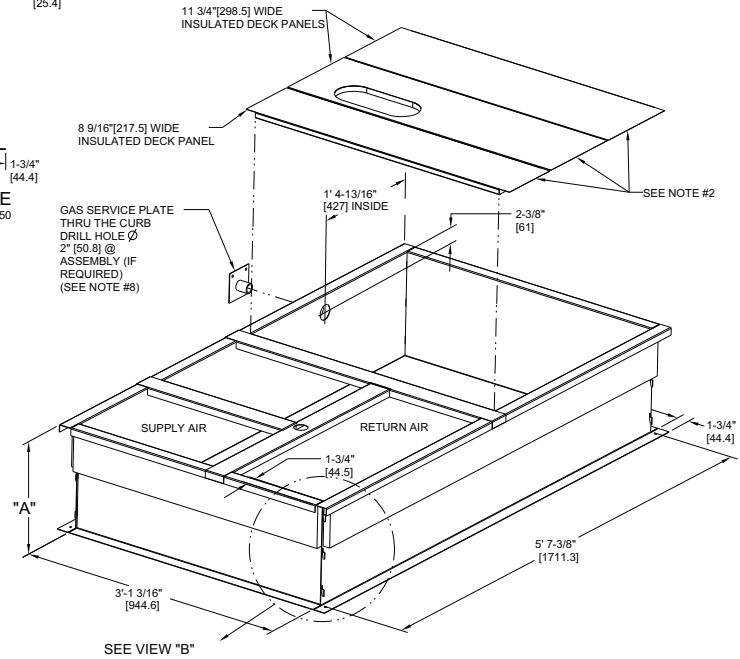
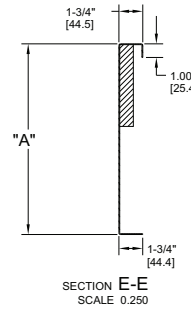
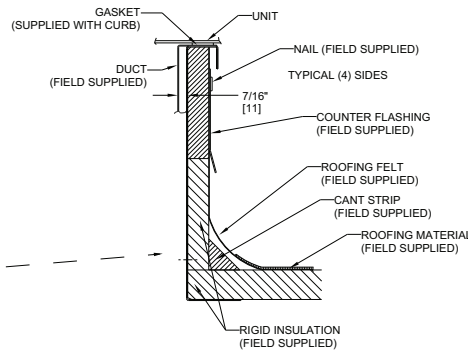
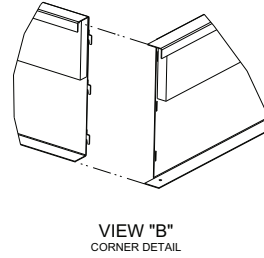
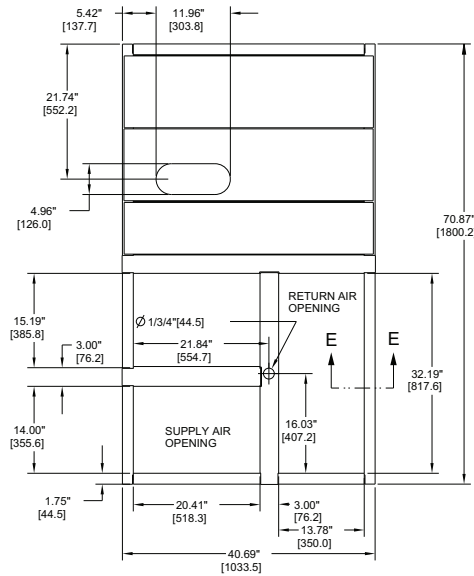

CERTIFIED DRAWING

DRAWING RELEASE LEVEL: PRODUCTION		UNLESS OTHERWISE SPECIFIED DIMENSIONS ARE IN INCHES TOLERANCES ON:		TITLE	
THIRD ANGLE PROJECTION		1 DEC ±	2 DEC ±	3 DEC ±	ANG ±
MATERIAL	-	AUTHORIZATION NUMBER			SIZE
ENGINEERING REQUIREMENTS	T-005, Y-002	1041738			
WEIGHT	-	ENGINEERING	MANUFACTURING	DRAWING NUMBER	
SURFACE FINISH	-	MMC	06/17/11	48TC400427	
MFG/PURCH	PURCH	MODEL (INTERNAL USE ONLY)			REV
				NEXT DRAWING	DISTRIBUTION
				SCALE	MMC

A	OVERALL DIM. 5'-7 3/8" WAS 5'-7 7/8; 18GA MATERIAL WA 16 GA.; NAIL FIELD SUPPLIED WAS WITH CURB	04/22/13	MMC	-	-	1067898
REV	REVISION RECORD	DATE	BY	CHKD	APPD	ECN NO.



50FCQA04 SINGLE STAGE COOLING CAPACITIES

50FCQA04				AMBIENT TEMPERATURE (F)												
				85			95			105			115			
				EAT (db)			EAT (db)			EAT (db)			EAT (db)			
				75	80	85	75	80	85	75	80	85	75	80	85	
900 Cfm	EAT (wb)	58	TC	30.8	30.8	34.8	28.8	28.8	32.6	26.6	26.6	30.2	24.2	24.2	27.5	
			SHC	26.7	30.8	34.8	24.9	28.8	32.6	23.0	26.6	30.2	20.9	24.2	27.5	
		62	TC	33.0	33.0	33.9	30.2	30.2	32.4	27.3	27.3	30.8	24.3	24.3	28.7	
			SHC	24.6	29.2	33.9	23.1	27.8	32.4	21.6	26.2	30.8	19.8	24.3	28.7	
		67	TC	37.4	37.4	37.4	34.7	34.7	34.7	31.5	31.5	31.5	28.2	28.2	28.2	
			SHC	20.6	25.2	29.8	19.4	24.0	28.6	17.8	22.5	27.1	16.3	20.9	25.5	
	72	TC	40.3	40.3	40.3	38.7	38.7	38.7	36.1	36.1	36.1	32.9	32.9	32.9		
		SHC	15.8	20.2	24.5	15.0	19.5	24.0	13.9	18.4	23.0	12.5	17.0	21.6		
	76	TC	—	41.4	41.4	—	40.4	40.4	—	38.5	38.5	—	35.9	35.9		
		SHC	—	16.2	21.0	—	15.5	20.1	—	14.6	19.1	—	13.5	17.9		
	1050 Cfm	EAT (wb)	58	TC	33.0	33.0	37.3	30.7	30.7	34.8	28.4	28.4	32.2	25.9	25.9	29.5
				SHC	28.6	33.0	37.3	26.7	30.7	34.8	24.6	28.4	32.2	22.4	25.9	29.5
62			TC	34.4	34.4	37.4	31.4	31.4	35.7	29.0	29.0	32.2	26.0	26.0	30.7	
			SHC	26.8	32.1	37.4	25.2	30.4	35.7	22.8	27.5	32.2	21.2	26.0	30.7	
67			TC	38.5	38.5	38.5	36.0	36.0	36.0	32.8	32.8	32.8	29.2	29.2	29.2	
			SHC	21.9	27.1	32.3	20.8	26.1	31.4	19.3	24.6	29.9	17.7	23.0	28.3	
72		TC	40.7	40.7	40.7	39.4	39.4	39.4	37.1	37.1	37.1	33.9	33.9	33.9		
		SHC	16.1	20.9	25.7	15.5	20.5	25.5	14.4	19.6	24.8	13.1	18.4	23.6		
76		TC	—	41.7	41.7	—	40.8	40.8	—	39.0	39.0	—	36.5	36.5		
		SHC	—	16.5	21.6	—	15.9	20.9	—	15.1	20.0	—	14.0	19.0		
1200 Cfm		EAT (wb)	58	TC	34.9	34.9	39.5	32.6	32.6	36.9	30.1	30.1	34.1	27.4	27.4	31.2
				SHC	30.3	34.9	39.5	28.3	32.6	36.9	26.0	30.1	34.1	23.7	27.4	31.2
	62		TC	35.5	35.5	40.5	32.6	32.6	38.4	30.1	30.1	35.5	27.5	27.5	32.4	
			SHC	28.7	34.6	40.5	26.9	32.6	38.4	24.7	30.1	35.5	22.5	27.5	32.4	
	67		TC	39.2	39.2	39.2	37.0	37.0	37.0	33.8	33.8	33.8	30.1	30.1	30.9	
			SHC	22.9	28.6	34.3	22.0	27.9	33.9	20.6	26.6	32.6	19.0	25.0	30.9	
	72	TC	41.1	41.1	41.1	39.9	39.9	39.9	37.7	37.7	37.7	34.7	34.7	34.7		
		SHC	16.4	21.5	26.6	15.8	21.3	26.7	14.9	20.6	26.3	13.6	19.5	25.4		
	76	TC	—	41.9	41.9	—	41.1	41.1	—	39.4	39.4	—	36.9	36.9		
		SHC	—	16.8	22.2	—	16.3	21.6	—	15.5	20.9	—	14.5	19.9		
	1350 Cfm	EAT (wb)	58	TC	36.4	36.4	41.2	34.2	34.2	38.7	31.5	31.5	35.7	28.7	28.7	32.6
				SHC	31.7	36.4	41.2	29.7	34.2	38.7	27.3	31.5	35.7	24.9	28.7	32.6
62			TC	36.5	36.5	42.9	34.2	34.2	40.2	31.6	31.6	37.2	28.8	28.8	34.0	
			SHC	30.2	36.5	42.9	28.2	34.2	40.2	26.0	31.6	37.2	23.6	28.8	34.0	
67			TC	39.7	39.7	39.7	37.7	37.7	37.7	34.6	34.6	35.2	30.8	30.8	33.5	
			SHC	23.7	29.9	36.1	23.1	29.6	36.1	21.9	28.5	35.2	20.2	26.9	33.5	
72		TC	41.3	41.3	41.3	40.2	40.2	40.2	38.1	38.1	38.1	35.2	35.2	35.2		
		SHC	16.6	22.0	27.5	16.1	21.9	27.8	15.2	21.4	27.6	14.1	20.5	27.0		
76		TC	—	42.0	42.0	—	41.3	41.3	—	39.6	39.6	—	37.1	37.1		
		SHC	—	17.0	22.7	—	16.5	22.2	—	15.8	21.6	—	14.8	20.8		
1500 Cfm		EAT (wb)	58	TC	37.6	37.6	42.5	35.5	35.5	40.1	32.8	32.8	37.2	29.9	29.9	33.9
				SHC	32.8	37.6	42.5	30.8	35.5	40.1	28.5	32.8	37.2	25.9	29.9	33.9
	62		TC	37.7	37.7	44.2	35.5	35.5	41.7	32.9	32.9	38.7	29.9	29.9	35.3	
			SHC	31.1	37.7	44.2	29.3	35.5	41.7	27.1	32.9	38.7	24.6	29.9	35.3	
	67		TC	40.0	40.0	40.0	38.2	38.2	38.2	35.2	35.2	37.5	31.4	31.4	35.9	
			SHC	24.4	31.0	37.6	24.1	31.1	38.2	23.0	30.2	37.5	21.4	28.7	35.9	
	72	TC	41.4	41.4	41.4	40.4	40.4	40.4	38.4	38.4	38.4	35.6	35.6	35.6		
		SHC	16.7	22.4	28.2	16.3	22.5	28.8	15.5	22.2	28.8	14.5	21.4	28.4		
	76	TC	—	42.1	42.1	—	41.5	41.5	—	39.8	39.8	—	37.3	37.3		
		SHC	—	17.2	23.1	—	16.8	22.8	—	16.1	22.2	—	15.2	21.5		

LEGEND

- Do Not Operate
- Cfm** — Cubic Feet Per Minute (Supply Air)
- EAT (db)** — Entering Air Temperature (dry bulb)
- EAT (wb)** — Entering Air Temperature (wet bulb)
- SHC** — Sensible Heat Capacity (1000 Btuh) Gross
- TC** — Total Capacity (1000 Btuh) Gross

NOTE: See minimum-maximum airflow ratings on page 6.

50FCQA05 SINGLE STAGE COOLING CAPACITIES

50FCQA05				AMBIENT TEMPERATURE (F)												
				85			95			105			115			
				EAT (db)			EAT (db)			EAT (db)			EAT (db)			
				75	80	85	75	80	85	75	80	85	75	80	85	
1200 Cfm	EAT (wb)	58	TC	42.2	42.2	47.7	39.8	39.8	45.0	37.1	37.1	42.0	34.1	34.1	38.6	
			SHC	36.7	42.2	47.7	34.6	39.8	45.0	32.2	37.1	42.0	29.6	34.1	38.6	
		62	TC	44.9	44.9	45.7	41.6	41.6	44.1	38.1	38.1	42.3	34.2	34.2	40.1	
			SHC	33.6	39.6	45.7	31.9	38.0	44.1	30.2	36.3	42.3	28.1	34.1	40.1	
		67	TC	50.1	50.1	50.1	47.1	47.1	47.1	43.3	43.3	43.3	39.3	39.3	39.3	
			SHC	27.9	33.9	39.8	26.5	32.5	38.5	24.8	30.9	36.9	23.1	29.2	35.3	
	72	TC	55.1	55.1	55.1	52.4	52.4	52.4	49.1	49.1	49.1	44.8	44.8	44.8		
		SHC	22.0	27.7	33.4	20.8	26.6	32.4	19.4	25.3	31.1	17.7	23.6	29.5		
	76	TC	—	58.7	58.7	—	56.0	56.0	—	53.1	53.1	—	49.5	49.5		
		SHC	—	22.6	29.2	—	21.5	28.1	—	20.5	25.6	—	19.0	24.2		
	1400 Cfm	EAT (wb)	58	TC	45.1	45.1	50.9	42.4	42.4	47.9	39.6	39.6	44.8	36.4	36.4	41.2
				SHC	39.3	45.1	50.9	36.9	42.4	47.9	34.4	39.6	44.8	31.7	36.4	41.2
62			TC	46.7	46.7	50.3	43.2	43.2	48.5	40.3	40.3	43.9	36.9	36.9	41.6	
			SHC	36.4	43.4	50.3	34.6	41.5	48.5	31.5	37.7	43.9	29.5	35.6	41.6	
67			TC	51.7	51.7	51.7	48.7	48.7	48.7	44.8	44.8	44.8	40.5	40.5	40.5	
			SHC	29.6	36.5	43.3	28.4	35.3	42.3	26.7	33.7	40.7	24.9	31.9	39.0	
72		TC	56.5	56.5	56.5	53.7	53.7	53.7	50.5	50.5	50.5	46.3	46.3	46.3		
		SHC	22.7	29.3	35.9	21.5	28.2	35.0	20.2	27.0	33.9	18.5	25.4	32.3		
76		TC	—	59.9	59.9	—	57.2	57.2	—	54.1	54.1	—	50.7	50.7		
		SHC	—	23.4	28.8	—	22.4	28.5	—	21.3	27.7	—	20.0	26.6		
1600 Cfm		EAT (wb)	58	TC	47.3	47.3	53.4	44.6	44.6	50.4	41.6	41.6	47.0	38.4	38.4	43.4
				SHC	41.2	47.3	53.4	38.8	44.6	50.4	36.2	41.6	47.0	33.4	38.4	43.4
	62		TC	48.1	48.1	54.4	44.9	44.9	51.8	41.9	41.9	47.9	38.4	38.4	45.2	
			SHC	38.8	46.6	54.4	36.7	44.2	51.8	33.9	40.9	47.9	31.7	38.4	45.2	
	67		TC	52.9	52.9	52.9	49.9	49.9	49.9	46.0	46.0	46.0	41.5	41.5	42.5	
			SHC	31.2	38.9	46.7	30.0	37.8	45.7	28.4	36.4	44.3	26.6	34.5	42.5	
	72	TC	57.5	57.5	57.5	54.8	54.8	54.8	51.5	51.5	51.5	47.3	47.3	47.3		
		SHC	23.3	30.7	38.1	22.1	29.7	37.2	20.9	28.6	36.3	19.3	27.1	34.9		
	76	TC	—	60.9	60.9	—	58.1	58.1	—	55.0	55.0	—	51.5	51.5		
		SHC	—	24.1	30.9	—	23.1	30.2	—	22.0	29.3	—	20.9	28.4		
	1800 Cfm	EAT (wb)	58	TC	49.2	49.2	55.5	46.7	46.7	52.7	43.4	43.4	49.0	40.0	40.0	45.3
				SHC	42.9	49.2	55.5	40.6	46.7	52.7	37.7	43.4	49.0	34.8	40.0	45.3
62			TC	49.7	49.7	56.9	47.1	47.1	53.1	43.4	43.4	50.9	40.1	40.1	47.1	
			SHC	40.5	48.7	56.9	37.9	45.5	53.1	35.9	43.4	50.9	33.1	40.1	47.1	
67			TC	53.8	53.8	53.8	50.8	50.8	50.8	46.9	46.9	47.7	42.3	42.3	45.8	
			SHC	32.6	41.2	49.7	31.5	40.2	48.9	30.0	38.8	47.7	28.1	36.9	45.8	
72		TC	58.3	58.3	58.3	55.5	55.5	55.5	52.3	52.3	52.3	48.1	48.1	48.1		
		SHC	23.8	32.0	40.2	22.7	31.0	39.3	21.5	30.0	38.5	19.9	28.6	37.3		
76		TC	—	61.6	61.6	—	58.8	58.8	—	55.6	55.6	—	52.1	52.1		
		SHC	—	24.8	32.6	—	23.8	31.7	—	22.7	30.8	—	21.6	30.0		
2000 Cfm		EAT (wb)	58	TC	50.7	50.7	57.2	48.3	48.3	54.5	44.9	44.9	50.8	41.4	41.4	46.8
				SHC	44.2	50.7	57.2	42.0	48.3	54.5	39.1	44.9	50.8	36.0	41.4	46.8
	62		TC	51.5	51.5	57.5	48.3	48.3	56.6	45.0	45.0	52.8	41.5	41.5	48.7	
			SHC	41.2	49.3	57.5	40.0	48.3	56.6	37.2	45.0	52.8	34.3	41.5	48.7	
	67		TC	54.6	54.6	54.6	51.6	51.6	51.9	47.7	47.7	50.9	43.0	43.0	49.0	
			SHC	33.9	43.2	52.5	32.9	42.4	51.9	31.5	41.2	50.9	29.6	39.3	49.0	
	72	TC	59.0	59.0	59.0	56.1	56.1	56.1	52.9	52.9	52.9	48.7	48.7	48.7		
		SHC	24.3	33.2	42.1	23.2	32.3	41.3	22.0	31.3	40.6	20.6	30.1	39.7		
	76	TC	—	62.1	62.1	—	59.3	59.3	—	56.0	56.0	—	52.6	52.6		
		SHC	—	25.5	34.1	—	24.5	33.2	—	23.3	32.2	—	22.3	31.4		

LEGEND

- Do Not Operate
- Cfm** — Cubic Feet Per Minute (Supply Air)
- EAT (db)** — Entering Air Temperature (dry bulb)
- EAT (wb)** — Entering Air Temperature (wet bulb)
- SHC** — Sensible Heat Capacity (1000 Btuh) Gross
- TC** — Total Capacity (1000 Btuh) Gross

NOTE: See minimum-maximum airflow ratings on page 6.



50FCQA06 SINGLE STAGE COOLING CAPACITIES

50FCQA06				AMBIENT TEMPERATURE (F)												
				85			95			105			115			
				EAT (db)			EAT (db)			EAT (db)			EAT (db)			
				75	80	85	75	80	85	75	80	85	75	80	85	
1500 Cfm	EAT (wb)	58	TC	53.2	53.2	60.1	49.8	49.8	56.3	46.2	46.2	52.3	42.4	42.4	48.0	
			SHC	46.3	53.2	60.1	43.3	49.8	56.3	40.1	46.2	52.3	36.7	42.4	48.0	
		62	TC	55.6	55.6	58.8	51.3	51.3	56.7	46.4	46.4	54.2	42.4	42.4	50.0	
			SHC	42.6	50.7	58.8	40.4	48.6	56.7	38.0	46.1	54.2	34.9	42.4	50.0	
		67	TC	62.7	62.7	62.7	58.2	58.2	58.2	53.5	53.5	53.5	48.1	48.1	48.1	
			SHC	35.4	43.4	51.5	33.3	41.4	49.5	31.2	39.3	47.4	28.9	37.0	45.1	
	72	TC	67.7	67.7	67.7	64.7	64.7	64.7	60.8	60.8	60.8	55.3	55.3	55.3		
		SHC	27.0	34.6	42.2	25.6	33.4	41.2	24.0	32.0	40.0	21.7	29.8	37.9		
	76	TC	—	73.5	73.5	—	69.7	69.7	—	66.0	66.0	—	61.5	61.5		
		SHC	—	28.5	35.0	—	27.0	34.1	—	25.5	33.1	—	23.9	31.7		
	1800 Cfm	EAT (wb)	58	TC	56.9	56.9	64.2	53.4	53.4	60.4	49.6	49.6	56.1	45.4	45.4	51.4
				SHC	49.5	56.9	64.2	46.5	53.4	60.4	43.1	49.6	56.1	39.4	45.4	51.4
62			TC	57.8	57.8	65.3	53.7	53.7	62.3	49.7	49.7	58.4	45.5	45.5	53.5	
			SHC	46.5	55.9	65.3	44.0	53.1	62.3	41.0	49.7	58.4	37.4	45.5	53.5	
67			TC	64.1	64.1	64.1	60.3	60.3	60.3	55.3	55.3	55.3	49.9	49.9	50.3	
			SHC	37.4	46.6	55.8	35.9	45.3	54.7	33.7	43.1	52.5	31.4	40.8	50.3	
72		TC	70.2	70.2	70.2	66.8	66.8	66.8	62.6	62.6	62.6	57.2	57.2	57.2		
		SHC	28.2	37.2	46.2	26.8	35.9	45.0	25.1	34.4	43.8	22.9	32.3	41.7		
76		TC	—	75.8	75.8	—	72.1	72.1	—	67.9	67.9	—	63.1	63.1		
		SHC	—	29.9	38.6	—	28.5	37.3	—	27.0	35.9	—	25.2	34.4		
2100 Cfm		EAT (wb)	58	TC	60.0	60.0	67.7	56.3	56.3	63.7	52.5	52.5	59.3	48.2	48.2	54.5
				SHC	52.2	60.0	67.7	49.0	56.3	63.7	45.6	52.5	59.3	41.8	48.2	54.5
	62		TC	60.1	60.1	70.4	56.4	56.4	66.2	52.5	52.5	61.7	48.2	48.2	56.8	
			SHC	49.7	60.1	70.4	46.6	56.4	66.2	43.4	52.5	61.7	39.7	48.2	56.8	
	67		TC	65.7	65.7	65.7	61.9	61.9	61.9	56.6	56.6	57.5	51.2	51.2	55.2	
			SHC	39.7	50.1	60.6	38.3	49.0	59.7	36.0	46.8	57.5	33.8	44.5	55.2	
	72	TC	72.0	72.0	72.0	68.6	68.6	68.6	64.1	64.1	64.1	58.5	58.5	58.5		
		SHC	29.3	39.6	49.9	27.9	38.3	48.7	26.1	36.8	47.4	24.0	34.6	45.3		
	76	TC	—	77.0	77.0	—	73.3	73.3	—	69.1	69.1	—	64.2	64.2		
		SHC	—	31.0	40.9	—	29.6	39.7	—	28.1	38.3	—	26.4	36.9		
	2400 Cfm	EAT (wb)	58	TC	62.7	62.7	70.8	58.9	58.9	66.5	54.8	54.8	61.9	50.5	50.5	57.1
				SHC	54.6	62.7	70.8	51.2	58.9	66.5	47.6	54.8	61.9	43.8	50.5	57.1
62			TC	62.8	62.8	73.6	58.9	58.9	69.2	54.9	54.9	64.4	50.5	50.5	59.4	
			SHC	52.0	62.8	73.6	48.7	58.9	69.2	45.3	54.9	64.4	41.7	50.5	59.4	
67			TC	67.3	67.3	67.3	63.2	63.2	64.5	57.8	57.8	62.3	52.2	52.2	60.0	
			SHC	42.1	53.8	65.6	40.5	52.5	64.5	38.3	50.3	62.3	36.0	48.0	60.0	
72		TC	73.5	73.5	73.5	69.7	69.7	69.7	65.2	65.2	65.2	59.5	59.5	59.5		
		SHC	30.3	41.8	53.3	28.8	40.4	52.0	27.1	38.9	50.8	24.9	36.9	48.9		
76		TC	—	78.1	78.1	—	74.2	74.2	—	69.9	69.9	—	65.1	65.1		
		SHC	—	32.1	43.2	—	30.7	41.9	—	29.1	40.5	—	27.5	39.2		
2700 Cfm		EAT (wb)	58	TC	64.6	64.6	72.9	61.0	61.0	69.0	56.8	56.8	64.2	52.3	52.3	59.2
				SHC	56.3	64.6	72.9	53.1	61.0	69.0	49.4	56.8	64.2	45.4	52.3	59.2
	62		TC	64.4	64.4	75.5	61.1	61.1	71.7	56.8	56.8	66.7	52.4	52.4	61.6	
			SHC	53.4	64.4	75.5	50.5	61.1	71.7	46.9	56.8	66.7	43.2	52.4	61.6	
	67		TC	68.3	68.3	70.0	64.2	64.2	69.1	58.8	58.8	67.1	53.1	53.1	64.6	
			SHC	44.1	57.1	70.0	42.7	55.9	69.1	40.5	53.8	67.1	38.1	51.4	64.6	
	72	TC	74.3	74.3	74.3	70.5	70.5	70.5	66.1	66.1	66.1	60.3	60.3	60.3		
		SHC	31.1	43.8	56.5	29.6	42.4	55.2	27.9	41.0	54.1	25.8	39.1	52.3		
	76	TC	—	78.9	78.9	—	74.9	74.9	—	70.6	70.6	—	65.8	65.8		
		SHC	—	33.0	45.2	—	31.7	44.1	—	30.1	42.7	—	28.6	41.5		

LEGEND

- Do Not Operate
- Cfm** — Cubic Feet Per Minute (Supply Air)
- EAT (db)** — Entering Air Temperature (dry bulb)
- EAT (wb)** — Entering Air Temperature (wet bulb)
- SHC** — Sensible Heat Capacity (1000 Btuh) Gross
- TC** — Total Capacity (1000 Btuh) Gross

NOTE: See minimum-maximum airflow ratings on page 6.

50FCQM07 HIGH STAGE COOLING CAPACITIES

50FCQM07				AMBIENT TEMPERATURE (F)												
				85			95			105			115			
				EAT (db)			EAT (db)			EAT (db)			EAT (db)			
				75	80	85	75	80	85	75	80	85	75	80	85	
1800 Cfm	EAT (wb)	58	TC	65.7	65.7	74.1	62.9	62.9	71.0	59.9	59.9	67.7	56.7	56.7	64.1	
			SHC	57.2	65.7	74.1	54.8	62.9	71.0	52.2	59.9	67.7	49.4	56.7	64.1	
		62	TC	68.3	68.3	71.8	64.8	64.8	70.0	61.0	61.0	68.2	57.0	57.0	66.2	
			SHC	52.3	62.0	71.8	50.5	60.3	70.0	48.7	58.5	68.2	46.7	56.5	66.2	
		67	TC	75.2	75.2	75.2	71.4	71.4	71.4	67.4	67.4	67.4	63.1	63.1	63.1	
			SHC	42.9	52.6	62.3	41.2	50.9	60.6	39.4	49.1	58.8	37.5	47.2	57.0	
	72	TC	81.1	81.1	81.1	78.4	78.4	78.4	74.4	74.4	74.4	69.7	69.7	69.7		
		SHC	32.6	41.7	50.9	31.5	41.0	50.6	29.9	39.5	49.2	28.0	37.7	47.4		
	76	TC	—	87.4	87.4	—	84.0	84.0	—	80.2	80.2	—	75.4	75.4		
		SHC	—	34.2	41.9	—	32.9	41.6	—	31.6	40.8	—	29.9	39.3		
	2100 Cfm	EAT (wb)	58	TC	69.4	69.4	78.3	66.4	66.4	75.0	63.2	63.2	71.4	59.8	59.8	67.5
				SHC	60.5	69.4	78.3	57.9	66.4	75.0	55.1	63.2	71.4	52.1	59.8	67.5
62			TC	70.5	70.5	79.3	66.8	66.8	77.3	63.3	63.3	74.1	59.9	59.9	70.2	
			SHC	56.7	68.0	79.3	54.8	66.1	77.3	52.4	63.2	74.1	49.5	59.9	70.2	
67			TC	77.5	77.5	77.5	73.5	73.5	73.5	69.2	69.2	69.2	64.7	64.7	64.7	
			SHC	45.7	57.0	68.3	44.0	55.3	66.6	42.2	53.5	64.8	40.3	51.6	62.9	
72		TC	84.1	84.1	84.1	80.8	80.8	80.8	76.2	76.2	76.2	71.4	71.4	71.4		
		SHC	34.1	45.0	55.8	32.9	44.1	55.3	31.1	42.3	53.6	29.2	40.5	51.7		
76		TC	—	90.5	90.5	—	86.7	86.7	—	82.3	82.3	—	77.1	77.1		
		SHC	—	36.1	46.4	—	34.7	45.3	—	33.2	44.2	—	31.4	42.5		
2400 Cfm		EAT (wb)	58	TC	72.6	72.6	81.9	69.4	69.4	78.3	66.0	66.0	74.5	62.4	62.4	70.4
				SHC	63.3	72.6	81.9	60.5	69.4	78.3	57.5	66.0	74.5	54.3	62.4	70.4
	62		TC	73.7	73.7	82.3	69.7	69.7	81.6	66.1	66.1	77.4	62.4	62.4	73.2	
			SHC	59.0	70.7	82.3	57.7	69.6	81.6	54.7	66.1	77.4	51.7	62.4	73.2	
	67		TC	79.2	79.2	79.2	75.0	75.0	75.0	70.6	70.6	70.6	65.9	65.9	68.7	
			SHC	48.5	61.3	74.2	46.7	59.6	72.4	44.9	57.7	70.6	42.9	55.8	68.7	
	72	TC	86.3	86.3	86.3	82.4	82.4	82.4	77.7	77.7	77.7	72.7	72.7	72.7		
		SHC	35.5	48.0	60.5	34.0	46.8	59.6	32.2	45.0	57.8	30.3	43.2	56.0		
	76	TC	—	92.8	92.8	—	88.7	88.7	—	83.8	83.8	—	78.5	78.5		
		SHC	—	37.7	49.7	—	36.3	48.7	—	34.7	47.2	—	32.9	45.5		
	2700 Cfm	EAT (wb)	58	TC	75.3	75.3	84.9	71.9	71.9	81.1	68.3	68.3	77.1	64.5	64.5	72.8
				SHC	65.6	75.3	84.9	62.7	71.9	81.1	59.5	68.3	77.1	56.2	64.5	72.8
62			TC	75.3	75.3	88.2	72.0	72.0	84.3	68.4	68.4	80.2	64.6	64.6	75.7	
			SHC	62.5	75.3	88.2	59.7	72.0	84.3	56.7	68.4	80.2	53.5	64.6	75.7	
67			TC	80.5	80.5	80.5	76.2	76.2	78.2	71.6	71.6	76.3	66.8	66.8	74.3	
			SHC	51.1	65.5	79.9	49.3	63.7	78.2	47.5	61.9	76.3	45.5	59.9	74.3	
72		TC	88.3	88.3	88.3	83.7	83.7	83.7	78.8	78.8	78.8	73.6	73.6	73.6		
		SHC	36.9	51.2	65.5	35.1	49.5	63.8	33.3	47.6	62.0	31.4	45.8	60.1		
76		TC	—	94.7	94.7	—	90.1	90.1	—	85.0	85.0	—	79.5	79.5		
		SHC	—	39.3	53.0	—	37.8	51.9	—	36.1	50.2	—	34.2	48.4		
3000 Cfm		EAT (wb)	58	TC	77.5	77.5	87.4	74.0	74.0	83.5	70.3	70.3	79.3	66.3	66.3	74.9
				SHC	67.6	77.5	87.4	64.6	74.0	83.5	61.3	70.3	79.3	57.8	66.3	74.9
	62		TC	77.6	77.6	90.9	74.1	74.1	86.8	70.4	70.4	82.5	66.4	66.4	77.8	
			SHC	64.4	77.6	90.9	61.4	74.1	86.8	58.3	70.4	82.5	55.0	66.4	77.8	
	67		TC	81.5	81.5	85.6	77.1	77.1	83.7	72.5	72.5	81.8	67.6	67.6	79.8	
			SHC	53.7	69.6	85.6	51.9	67.8	83.7	50.0	65.9	81.8	48.0	63.9	79.8	
	72	TC	89.4	89.4	89.4	84.7	84.7	84.7	79.7	79.7	79.7	74.4	74.4	74.4		
		SHC	37.9	53.8	69.6	36.2	52.0	67.9	34.3	50.2	66.1	32.4	48.3	64.2		
	76	TC	—	96.1	96.1	—	91.2	91.2	—	85.9	85.9	—	80.3	80.3		
		SHC	—	40.8	56.3	—	39.2	54.8	—	37.4	53.1	—	35.6	51.3		

LEGEND

- Do Not Operate
- Cfm** — Cubic Feet Per Minute (Supply Air)
- EAT (db)** — Entering Air Temperature (dry bulb)
- EAT (wb)** — Entering Air Temperature (wet bulb)
- SHC** — Sensible Heat Capacity (1000 Btuh) Gross
- TC** — Total Capacity (1000 Btuh) Gross

NOTE: See minimum-maximum airflow ratings on page 6.



50FCQM07 LOW STAGE COOLING CAPACITIES

50FCQM07				AMBIENT TEMPERATURE (F)												
				85			95			105			115			
				EAT (db)			EAT (db)			EAT (db)			EAT (db)			
				75	80	85	75	80	85	75	80	85	75	80	85	
1500 Cfm	EAT (wb)	58	TC	49.6	49.6	56.1	47.3	47.3	53.5	44.6	44.6	50.5	41.7	41.7	47.2	
			SHC	43.1	49.6	56.1	41.0	47.3	53.5	38.7	44.6	50.5	36.1	41.7	47.2	
		62	TC	50.8	50.8	56.3	47.8	47.8	54.8	45.2	45.2	51.4	41.7	41.7	49.2	
			SHC	40.2	48.3	56.3	38.6	46.7	54.8	36.3	43.9	51.4	34.3	41.7	49.2	
		67	TC	56.6	56.6	56.6	53.3	53.3	53.3	49.7	49.7	49.7	45.8	45.8	45.8	
			SHC	32.6	40.7	48.8	31.1	39.2	47.3	29.5	37.6	45.7	27.8	35.9	44.0	
	72	TC	61.9	61.9	61.9	59.2	59.2	59.2	55.7	55.7	55.7	51.5	51.5	51.5		
		SHC	24.4	32.1	39.7	23.3	31.2	39.1	21.9	29.9	37.9	20.2	28.2	36.3		
	76	TC	—	67.3	67.3	—	64.3	64.3	—	60.7	60.7	—	56.3	56.3		
		SHC	—	26.0	32.9	—	24.9	32.3	—	23.6	31.3	—	22.0	29.8		
	1750 Cfm	EAT (wb)	58	TC	52.9	52.9	59.8	50.3	50.3	56.9	47.4	47.4	53.7	44.2	44.2	50.1
				SHC	45.9	52.9	59.8	43.6	50.3	56.9	41.1	47.4	53.7	38.3	44.2	50.1
62			TC	53.0	53.0	61.9	50.3	50.3	59.2	47.4	47.4	55.9	44.2	44.2	52.2	
			SHC	43.5	52.7	61.9	41.4	50.3	59.2	39.0	47.4	55.9	36.3	44.2	52.2	
67			TC	58.3	58.3	58.3	54.8	54.8	54.8	51.0	51.0	51.3	46.9	46.9	49.5	
			SHC	35.1	44.8	54.4	33.6	43.2	52.9	31.9	41.6	51.3	30.2	39.9	49.5	
72		TC	64.3	64.3	64.3	61.1	61.1	61.1	57.0	57.0	57.0	52.6	52.6	52.6		
		SHC	25.6	34.9	44.2	24.3	33.9	43.5	22.7	32.3	42.0	21.0	30.6	40.3		
76		TC	—	69.9	69.9	—	66.4	66.4	—	62.3	62.3	—	57.6	57.6		
		SHC	—	27.5	36.5	—	26.2	35.4	—	24.8	34.2	—	23.1	32.6		
2000 Cfm		EAT (wb)	58	TC	55.3	55.3	62.6	52.5	52.5	59.5	49.4	49.4	56.0	46.0	46.0	52.3
				SHC	48.0	55.3	62.6	45.5	52.5	59.5	42.8	49.4	56.0	39.8	46.0	52.3
	62		TC	55.3	55.3	65.1	52.5	52.5	61.9	49.5	49.5	58.3	46.1	46.1	54.4	
			SHC	45.6	55.3	65.1	43.2	52.5	61.9	40.6	49.5	58.3	37.8	46.1	54.4	
	67		TC	59.2	59.2	59.7	55.6	55.6	58.2	51.7	51.7	56.5	47.4	47.4	54.7	
			SHC	37.3	48.5	59.7	35.8	47.0	58.2	34.1	45.3	56.5	32.3	43.5	54.7	
	72	TC	65.8	65.8	65.8	62.0	62.0	62.0	57.8	57.8	57.8	53.2	53.2	53.2		
		SHC	26.4	37.5	48.6	24.9	36.1	47.3	23.3	34.5	45.7	21.5	32.7	43.9		
	76	TC	—	71.4	71.4	—	67.5	67.5	—	63.0	63.0	—	58.2	58.2		
		SHC	—	28.5	39.2	—	27.2	38.2	—	25.7	36.6	—	24.0	35.0		
	2250 Cfm	EAT (wb)	58	TC	57.1	57.1	64.7	54.1	54.1	61.4	50.8	50.8	57.7	47.3	47.3	53.8
				SHC	49.5	57.1	64.7	46.9	54.1	61.4	44.0	50.8	57.7	40.8	47.3	53.8
62			TC	57.1	57.1	67.3	54.2	54.2	63.8	50.9	50.9	60.1	47.3	47.3	56.0	
			SHC	47.0	57.1	67.3	44.5	54.2	63.8	41.7	50.9	60.1	38.7	47.3	56.0	
67			TC	59.7	59.7	64.7	56.0	56.0	63.1	51.9	51.9	61.4	47.6	47.6	59.4	
			SHC	39.2	52.0	64.7	37.7	50.4	63.1	35.9	48.7	61.4	34.1	46.8	59.4	
72		TC	66.4	66.4	66.4	62.4	62.4	62.4	58.0	58.0	58.0	53.3	53.3	53.3		
		SHC	26.9	39.5	52.2	25.3	38.0	50.7	23.6	36.4	49.1	21.9	34.6	47.3		
76		TC	—	72.1	72.1	—	68.0	68.0	—	63.3	63.3	—	58.4	58.4		
		SHC	—	29.3	41.6	—	27.9	40.4	—	26.3	38.8	—	24.6	37.2		
2500 Cfm		EAT (wb)	58	TC	58.3	58.3	66.1	55.2	55.2	62.7	51.8	51.8	58.9	48.1	48.1	54.7
				SHC	50.4	58.3	66.1	47.7	55.2	62.7	44.7	51.8	58.9	41.4	48.1	54.7
	62		TC	58.3	58.3	68.8	55.2	55.2	65.2	51.8	51.8	61.3	48.1	48.1	57.0	
			SHC	47.8	58.3	68.8	45.2	55.2	65.2	42.3	51.8	61.3	39.2	48.1	57.0	
	67		TC	59.7	59.7	69.3	56.0	56.0	67.6	52.0	52.0	65.5	48.2	48.2	61.1	
			SHC	40.9	55.1	69.3	39.3	53.4	67.6	37.4	51.5	65.5	34.7	47.9	61.1	
	72	TC	66.4	66.4	66.4	62.3	62.3	62.3	57.8	57.8	57.8	53.0	53.0	53.0		
		SHC	27.0	41.2	55.4	25.4	39.7	53.9	23.8	38.0	52.2	22.0	36.2	50.5		
	76	TC	—	72.3	72.3	—	67.9	67.9	—	63.2	63.2	—	58.1	58.1		
		SHC	—	29.8	43.8	—	28.3	42.3	—	26.7	40.8	—	25.0	39.1		

- LEGEND**
- Do Not Operate
 - Cfm** — Cubic Feet Per Minute (Supply Air)
 - EAT (db)** — Entering Air Temperature (dry bulb)
 - EAT (wb)** — Entering Air Temperature (wet bulb)
 - SHC** — Sensible Heat Capacity (1000 Btuh) Gross
 - TC** — Total Capacity (1000 Btuh) Gross

NOTE: See minimum-maximum airflow ratings on page 6.

50FCQA04 HEATING CAPACITIES

		50FCQA04 (3 Tons)									
Return Air (°F db)	CFM (Standard Air)	Temperature Air Entering Outdoor Coil (°F db at 70% rh)									
		-10	0	10	17	30	40	47	50	60	
55	900	Capacity	10.0	13.5	17.3	20.1	26.0	31.1	34.5	35.5	40.2
		Int. Cap.	9.2	12.5	15.9	18.4	22.8	31.1	34.5	35.5	40.2
	1200	Capacity	10.4	13.9	17.8	20.7	26.8	31.9	35.1	36.2	41.1
		Int. Cap.	9.6	12.8	16.3	18.9	23.5	31.9	35.1	36.2	41.1
	1500	Capacity	10.4	14.1	18.1	21.0	27.4	32.1	35.4	36.5	41.4
		Int. Cap.	9.6	13.0	16.6	19.1	24.0	32.1	35.4	36.5	41.4
70	900	Capacity	8.2	11.7	15.6	18.4	24.1	28.8	32.9	33.9	38.6
		Int. Cap.	7.6	10.8	14.3	16.8	21.1	28.8	32.9	33.9	38.6
	1200	Capacity	8.5	12.2	16.1	19.1	25.0	30.1	34.1	34.9	39.6
		Int. Cap.	7.9	11.2	14.8	17.4	21.9	30.1	34.1	34.9	39.6
	1500	Capacity	8.7	12.5	16.5	19.4	25.6	30.9	34.3	35.3	39.9
		Int. Cap.	8.1	11.5	15.1	17.7	22.4	30.9	34.3	35.3	39.9
80	900	Capacity	6.7	10.3	14.1	17.0	22.6	27.4	31.1	32.5	37.4
		Int. Cap.	6.2	9.5	13.0	15.5	19.8	27.4	31.1	32.5	37.4
	1200	Capacity	7.0	10.8	14.7	17.7	23.5	28.6	32.7	33.8	38.5
		Int. Cap.	6.5	9.9	13.5	16.1	20.6	28.6	32.7	33.8	38.5
	1500	Capacity	7.2	11.0	15.1	18.1	24.1	29.3	33.4	34.4	39.0
		Int. Cap.	6.7	10.2	13.9	16.5	21.1	29.3	33.4	34.4	39.0

LEGEND

- Indicates standard rating point
- Capacity** — Instantaneous Capacity (1000 Btuh) - includes indoor fan motor heat at AHRI static conditions
- Int. Cap.** — Integrated Capacity = instantaneous capacity minus the effects of frost on the OD coil and the heat required to defrost it
- rh** — Relative Humidity
- db** — Dry Bulb



50FCQA05 HEATING CAPACITIES

		50FCQA05 (4 Tons)									
Return Air (°F db)	CFM (Standard Air)	Temperature Air Entering Outdoor Coil (°F db at 70% rh)									
		-10	0	10	17	30	40	47	50	60	
55	1200	Capacity	17.8	22.3	26.9	30.3	37.1	42.9	47.4	49.2	55.6
		Int. Cap.	16.4	20.5	24.7	27.6	32.5	42.9	47.4	49.2	55.6
	1600	Capacity	17.8	22.4	27.0	30.5	37.6	43.8	48.2	50.1	56.4
		Int. Cap.	16.4	20.6	24.8	27.8	33.0	43.8	48.2	50.1	56.4
	2000	Capacity	18.8	23.4	28.1	31.6	39.0	45.2	49.4	51.2	57.4
		Int. Cap.	17.3	21.5	25.8	28.9	34.1	45.2	49.4	51.2	57.4
70	1200	Capacity	16.1	20.6	25.3	28.6	35.3	40.8	45.0	47.0	53.3
		Int. Cap.	14.9	19.0	23.2	26.0	30.9	40.8	45.0	47.0	53.3
	1600	Capacity	16.2	20.8	25.6	29.0	35.9	41.6	46.1	48.1	54.2
		Int. Cap.	15.0	19.2	23.5	26.4	31.4	41.6	46.1	48.1	54.2
	2000	Capacity	17.3	22.0	26.8	30.2	37.2	43.2	47.6	49.4	55.5
		Int. Cap.	16.0	20.2	24.6	27.5	32.6	43.2	47.6	49.4	55.5
80	1200	Capacity	16.1	20.6	25.3	28.6	35.3	40.8	45.0	47.0	53.3
		Int. Cap.	14.9	19.0	23.2	26.0	30.9	40.8	45.0	47.0	53.3
	1600	Capacity	14.7	19.4	24.2	27.7	34.5	40.1	44.5	46.4	52.7
		Int. Cap.	13.6	17.9	22.2	25.3	30.3	40.1	44.5	46.4	52.7
	2000	Capacity	15.8	20.6	25.5	29.0	35.9	41.7	46.2	48.1	54.1
		Int. Cap.	14.6	19.0	23.4	26.4	31.5	41.7	46.2	48.1	54.1

LEGEND

- Indicates standard rating point
- Capacity** — Instantaneous Capacity (1000 Btuh) - includes indoor fan motor heat at AHRI static conditions
- Int. Cap.** — Integrated Capacity = instantaneous capacity minus the effects of frost on the OD coil and the heat required to defrost it
- rh** — Relative Humidity
- db** — Dry Bulb

50FCQA06 HEATING CAPACITIES

		50FCQA06 (5 Tons)									
Return Air (°F db)	CFM (Standard Air)	Temperature Air Entering Outdoor Coil (°F db at 70% rh)									
		-10	0	10	17	30	40	47	50	60	
55	1500	Capacity	21.1	26.7	32.6	37.0	45.8	52.7	58.4	61.0	68.7
		Int. Cap.	19.5	24.6	30.0	33.7	40.1	52.7	58.4	61.0	68.7
	2000	Capacity	21.2	26.9	32.8	37.3	46.3	53.7	59.3	61.5	69.3
		Int. Cap.	19.6	24.8	30.1	34.0	40.6	53.7	59.3	61.5	69.3
	2500	Capacity	22.6	28.4	34.3	38.8	48.0	55.3	60.7	62.8	70.4
		Int. Cap.	20.9	26.1	31.5	35.4	42.1	55.3	60.7	62.8	70.4
70	1500	Capacity	18.3	24.2	30.3	34.7	43.6	50.1	56.0	58.4	66.3
		Int. Cap.	16.9	22.3	27.8	31.7	38.2	50.1	56.0	58.4	66.3
	2000	Capacity	18.5	24.5	30.7	35.1	44.2	51.3	56.8	59.4	67.2
		Int. Cap.	17.1	22.5	28.1	32.0	38.7	51.3	56.8	59.4	67.2
	2500	Capacity	19.9	26.0	32.2	36.7	45.9	53.1	58.8	61.1	68.6
		Int. Cap.	18.4	23.9	29.6	33.5	40.2	53.1	58.8	61.1	68.6
80	1500	Capacity	16.0	22.1	28.4	33.0	41.9	48.6	54.1	56.6	64.5
		Int. Cap.	14.8	20.4	26.1	30.0	36.7	48.6	54.1	56.6	64.5
	2000	Capacity	16.2	22.5	28.9	33.5	42.7	49.6	55.0	57.8	65.6
		Int. Cap.	15.0	20.7	26.5	30.5	37.4	49.6	55.0	57.8	65.6
	2500	Capacity	17.7	24.0	30.5	35.2	44.4	51.5	57.2	59.5	67.2
		Int. Cap.	16.3	22.1	28.0	32.1	38.9	51.5	57.2	59.5	67.2

LEGEND

 — Indicates standard rating point

 — Indicates operation not permissible

Capacity — Instantaneous Capacity (1000 Btuh) - includes indoor fan motor heat at AHRI static conditions

Int. Cap. — Integrated Capacity = instantaneous capacity minus the effects of frost on the OD coil and the heat required to defrost it

rh — Relative Humidity

db — Dry Bulb



50FCQM07 HEATING CAPACITIES

50FCQM07 (6 Tons)											
Return Air (°F db)	CFM (Standard Air)	Temperature Air Entering Outdoor Coil (°F db at 70% rh)									
		-10	0	10	17	30	40	47	50	60	
55	1800	Capacity	20.9	28.1	35.9	40.7	50.1	59.7	66.0	68.6	77.7
		Int. Cap.	19.3	25.9	33.0	37.1	43.9	59.7	66.0	68.6	77.7
	2400	Capacity	22.4	29.8	37.3	42.8	52.6	62.2	68.5	71.2	80.4
		Int. Cap.	20.7	27.4	34.3	39.0	46.1	62.2	68.5	71.2	80.4
	3000	Capacity	25.2	31.5	39.0	44.6	55.1	64.3	70.3	72.9	81.7
		Int. Cap.	23.3	28.9	35.8	40.7	48.3	64.3	70.3	72.9	81.7
70	1800	Capacity	16.0	23.5	31.1	36.5	45.6	54.7	62.0	64.7	73.6
		Int. Cap.	14.8	21.6	28.5	33.3	40.0	54.7	62.0	64.7	73.6
	2400	Capacity	17.6	25.4	33.2	38.7	48.4	58.2	65.1	67.7	76.7
		Int. Cap.	16.3	23.4	30.5	35.3	42.4	58.2	65.1	67.7	76.7
	3000	Capacity	19.2	27.2	35.1	40.7	50.7	61.0	67.2	69.8	78.7
		Int. Cap.	17.7	25.0	32.3	37.1	44.4	61.0	67.2	69.8	78.7
80	1800	Capacity	12.2	19.8	27.6	33.1	42.1	51.0	58.0	61.3	70.5
		Int. Cap.	11.2	18.2	25.3	30.1	36.9	51.0	58.0	61.3	70.5
	2400	Capacity	13.6	21.7	29.8	35.5	45.1	54.5	62.2	65.0	73.9
		Int. Cap.	12.6	20.0	27.3	32.3	39.5	54.5	62.2	65.0	73.9
	3000	Capacity	15.3	23.5	31.8	37.6	47.5	57.3	64.8	67.4	76.2
		Int. Cap.	14.1	21.7	29.2	34.3	41.6	57.3	64.8	67.4	76.2

LEGEND

- Indicates standard rating point
- Capacity** — Instantaneous Capacity (1000 Btuh) - includes indoor fan motor heat at AHRI static conditions
- Int. Cap.** — Integrated Capacity = instantaneous capacity minus the effects of frost on the OD coil and the heat required to defrost it
- rh** — Relative Humidity
- db** — Dry Bulb

PRESSURE DROPS FOR ELECTRIC HEATING UNITS

Pressure Drop for Electric Heat 3 to 5 Ton Units - 1 stage heat

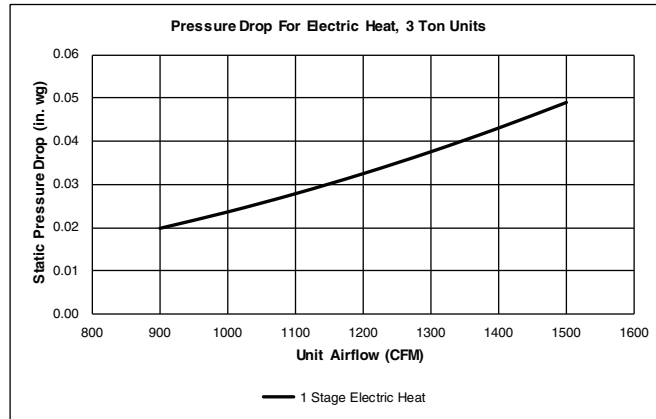

Pressure Drop for Electric Heat 4 to 6 Ton Units - 1 and 2 Stage Heat

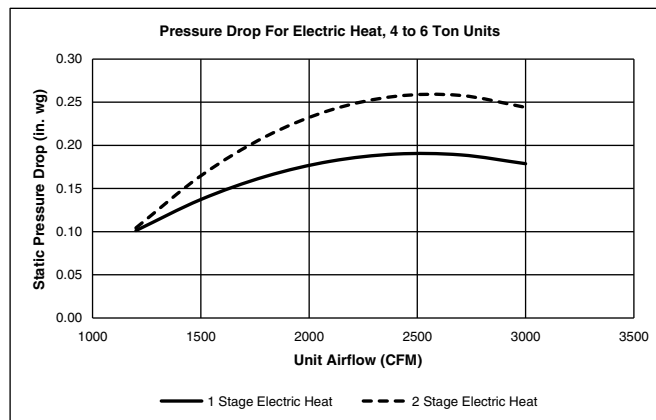



FIELD-INSTALLED ACCESSORY ELECTRIC HEATER DATA

50FCQ UNIT SIZE	VOLTAGE	HEATER MODEL NUMBER*	NUMBER OF STAGES
04	208/230	CRHEATER323A00	1
		CRHEATER324A00	1
		CRHEATER325A00	1
		CRHEATER326A00	1
		CRHEATER327A00	2
		CRHEATER328A00	1
	460	CRHEATER333A00	1
		CRHEATER334A00	1
		CRHEATER335A00	1
		CRHEATER336A00	1
575	CRHEATER339A00	1	
	CRHEATER340A00	1	
05	208/230	CRHEATER323A00	1
		CRHEATER324A00	1
		CRHEATER325A00	1
		CRHEATER326A00	1
		CRHEATER327A00	2
		CRHEATER328A00	1
		CRHEATER329A00	2
		CRHEATER330A00†	2
	CRHEATER331A00**	2	
	460	CRHEATER333A00	1
		CRHEATER335A00	1
		CRHEATER336A00	1
		CRHEATER337A00	2
	575	CRHEATER339A00	1
CRHEATER340A00		1	
06, 07	208/230	CRHEATER324A00	1
		CRHEATER325A00	1
		CRHEATER326A00	1
		CRHEATER327A00	2
		CRHEATER328A00	1
		CRHEATER329A00	2
	460	CRHEATER331A00	2
		CRHEATER332A00	2
		CRHEATER333A00	1
		CRHEATER335A00	1
		CRHEATER336A00	1
		CRHEATER337A00	2
575	CRHEATER338A00	2	
	CRHEATER340A00	1	
		CRHEATER341A00	2

*Check heater nameplate for model number.

†Do not use with size 05 horizontal supply duct configuration units.

**Do not use with size 05 vertical supply duct configuration units.

USE OF CRHEATER330A00 FOR 50FCQ UNITS (WITH OR WITHOUT NON-FUSED DISCONNECT)

DUCT CONFIGURATION	50FCQ UNIT SIZE			
	04	05	06	07
Vertical Supply	Not available	Available	Not available	Not available
Horizontal Supply	Not available	Not available	Not available	Not available

USE OF CRHEATER331A00 FOR 50FCQ UNITS (WITH OR WITHOUT NON-FUSED DISCONNECT)

DUCT CONFIGURATION	50FCQ UNIT SIZE			
	04	05	06	07
Vertical Supply	Not available	Not available	Available	Available
Horizontal Supply	Not available	Available	Available	Available

ECONOMIZER BAROMETRIC RELIEF AND STATIC PRESSURE

HORIZONTAL ECONOMIZER BAROMETRIC RELIEF

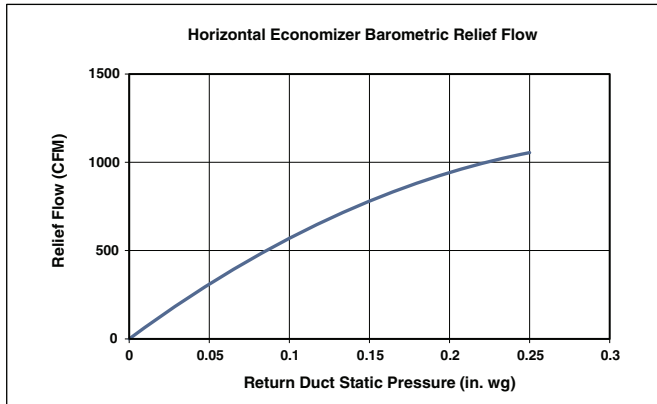

VERTICAL ECONOMIZER BAROMETRIC RELIEF

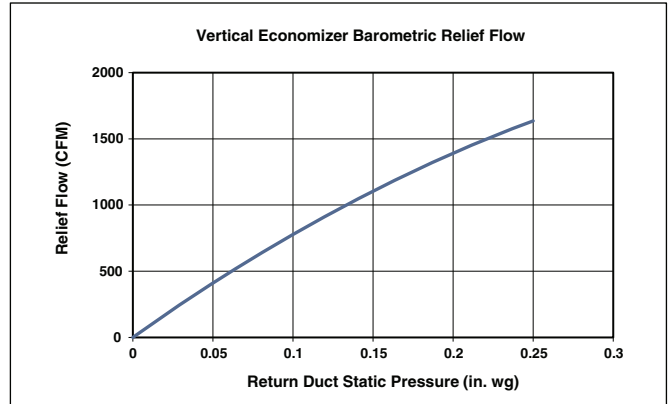

HORIZONTAL ECONOMIZER DAMPER LEAKAGE

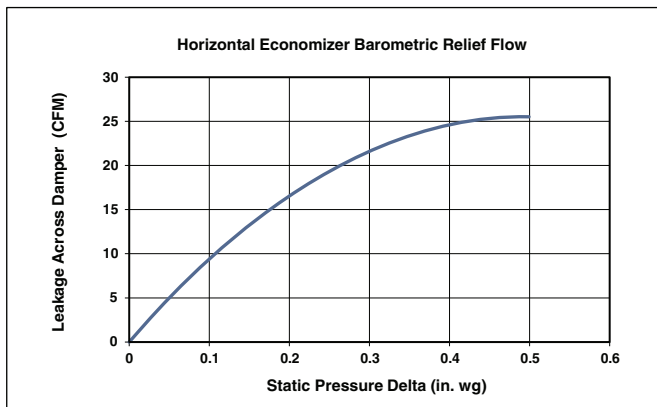

VERTICAL ECONOMIZER DAMPER LEAKAGE

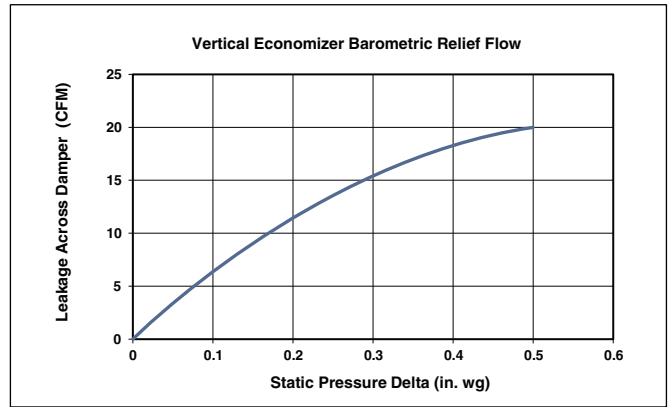

MERV-8 filters pressure drop

NOTE: For factory-installed MERV-8 filters, no additional pressure drop adjustments are necessary. The standard fan tables accommodate usage.

GENERAL FAN PERFORMANCE NOTES

1. Interpolation is permissible. Do not extrapolate.
2. External static pressure is the static pressure difference between the return duct and the supply duct plus the static pressure caused by any FIOPs or accessories.
3. Tabular data accounts for pressure loss due to clean filters, unit casing, and wet coils.
4. Factory options and accessories may effect static pressure losses. Selection software is available, through your salesperson, to help you select the best motor/drive combination for your application.
5. The fan performance tables offer motor/drive recommendations. In cases when two motor/drive combinations would work, Carrier recommends the lower horsepower option.
6. For information on the electrical properties of Carrier motors, please see the Electrical Data section of this book.
7. For more information on the performance limits of Carrier motors, see the application data section of this book.
8. The EPACT (Energy Policy Act of 1992) regulates energy requirements for specific types of indoor fan motors. Motors regulated by EPACT include any general purpose, T-frame (three-digit, 143 and larger), single-speed, foot mounted, polyphase, squirrel cage induction motors of NEMA (National Electrical Manufacturers Association) design A and B, manufactured for use in the United States. Ranging from 1 to 200 Hp, these continuous-duty motors operate on 230 and 460 volt, 60 Hz power. If a motor does not fit into these specifications, the motor does not have to be replaced by an EPACT compliant energy-efficient motor. Variable-speed motors are exempt from EPACT compliance requirements.

50FCQA04 SINGLE PHASE — 3 TON VERTICAL SUPPLY (RPM - BHP)

CFM	AVAILABLE EXTERNAL STATIC PRESSURE (in. wg)									
	0.2		0.4		0.6		0.8		1.0	
	RPM	BHP	RPM	BHP	RPM	BHP	RPM	BHP	RPM	BHP
900	1060	0.08	1325	0.16	1541	0.25	1718	0.35	1871	0.46
975	1103	0.09	1355	0.17	1572	0.27	1752	0.37	1906	0.48
1050	1150	0.11	1387	0.19	1602	0.29	1784	0.40	1941	0.51
1125	1198	0.12	1422	0.20	1632	0.30	1815	0.42	1974	0.54
1200	1249	0.14	1459	0.22	1662	0.32	1845	0.44	2005	0.56
1275	1303	0.15	1499	0.23	1694	0.34	1874	0.46	2036	0.59
1350	1357	0.17	1542	0.26	1728	0.36	1905	0.48	2066	0.61
1425	1413	0.20	1587	0.28	1765	0.38	1936	0.51	2095	0.64
1500	1469	0.22	1635	0.30	1803	0.41	1969	0.53	2126	0.67

CFM	AVAILABLE EXTERNAL STATIC PRESSURE (in. wg)									
	1.2		1.4		1.6		1.8		2.0	
	RPM	BHP	RPM	BHP	RPM	BHP	RPM	BHP	RPM	BHP
900	2006	0.56	2130	0.67	2244	0.79	2352	0.91	2454	1.03
975	2044	0.59	2168	0.71	2283	0.83	2391	0.95	—	—
1050	2080	0.63	2206	0.75	2322	0.87	2430	1.00	—	—
1125	2115	0.66	2242	0.78	2359	0.91	2468	1.05	—	—
1200	2148	0.69	2277	0.82	2396	0.96	—	—	—	—
1275	2180	0.72	2311	0.86	2431	1.00	—	—	—	—
1350	2211	0.75	2343	0.90	2465	1.04	—	—	—	—
1425	2241	0.78	2375	0.93	—	—	—	—	—	—
1500	2271	0.82	2405	0.97	—	—	—	—	—	—

Standard Static 1060-1890 RPM, 0.44 Max BHP

Medium Static 1060-2190 RPM, 0.71 Max BHP

High Static 1060-2490 RPM, 1.07 Max BHP

50FCQA04 SINGLE PHASE - STANDARD STATIC — 3 TON VERTICAL SUPPLY (RPM - VDC)

CFM	AVAILABLE EXTERNAL STATIC PRESSURE (in. wg)									
	0.2		0.4		0.6		0.8		1.0	
	RPM	Vdc	RPM	Vdc	RPM	Vdc	RPM	Vdc	RPM	Vdc
900	1060	5.6	1325	7.0	1541	8.2	1718	9.1	1871	9.9
975	1103	5.8	1355	7.2	1572	8.3	1752	9.3	—	—
1050	1150	6.1	1387	7.3	1602	8.5	1784	9.4	—	—
1125	1198	6.3	1422	7.5	1632	8.6	1815	9.6	—	—
1200	1249	6.6	1459	7.7	1662	8.8	1845	9.8	—	—
1275	1303	6.9	1499	7.9	1694	9.0	1874	9.9	—	—
1350	1357	7.2	1542	8.2	1728	9.1	—	—	—	—
1425	1413	7.5	1587	8.4	1765	9.3	—	—	—	—
1500	1469	7.8	1635	8.7	1803	9.5	—	—	—	—

CFM	AVAILABLE EXTERNAL STATIC PRESSURE (in. wg)									
	1.2		1.4		1.6		1.8		2.0	
	RPM	Vdc	RPM	Vdc	RPM	Vdc	RPM	Vdc	RPM	Vdc
900	—	—	—	—	—	—	—	—	—	—
975	—	—	—	—	—	—	—	—	—	—
1050	—	—	—	—	—	—	—	—	—	—
1125	—	—	—	—	—	—	—	—	—	—
1200	—	—	—	—	—	—	—	—	—	—
1275	—	—	—	—	—	—	—	—	—	—
1350	—	—	—	—	—	—	—	—	—	—
1425	—	—	—	—	—	—	—	—	—	—
1500	—	—	—	—	—	—	—	—	—	—

Standard Static 1060-1890 RPM



50FCQA04 SINGLE PHASE - MEDIUM STATIC — 3 TON VERTICAL SUPPLY (RPM - VDC)

CFM	AVAILABLE EXTERNAL STATIC PRESSURE (in. wg)									
	0.2		0.4		0.6		0.8		1.0	
	RPM	Vdc	RPM	Vdc	RPM	Vdc	RPM	Vdc	RPM	Vdc
900	1060	4.8	1325	6.1	1541	7.0	1718	7.8	1871	8.5
975	1103	5.0	1355	6.2	1572	7.2	1752	8.0	1906	8.7
1050	1150	5.3	1387	6.3	1602	7.3	1784	8.1	1941	8.9
1125	1198	5.5	1422	6.5	1632	7.5	1815	8.3	1974	9.0
1200	1249	5.7	1459	6.7	1662	7.6	1845	8.4	2005	9.2
1275	1303	5.9	1499	6.8	1694	7.7	1874	8.6	2036	9.3
1350	1357	6.2	1542	7.0	1728	7.9	1905	8.7	2066	9.4
1425	1413	6.5	1587	7.2	1765	8.1	1936	8.8	2095	9.6
1500	1469	6.7	1635	7.5	1803	8.2	1969	9.0	2126	9.7

CFM	AVAILABLE EXTERNAL STATIC PRESSURE (in. wg)									
	1.2		1.4		1.6		1.8		2.0	
	RPM	Vdc	RPM	Vdc	RPM	Vdc	RPM	Vdc	RPM	Vdc
900	2006	9.2	2130	9.7	—	—	—	—	—	—
975	2044	9.3	2168	9.9	—	—	—	—	—	—
1050	2080	9.5	—	—	—	—	—	—	—	—
1125	2115	9.7	—	—	—	—	—	—	—	—
1200	2148	9.8	—	—	—	—	—	—	—	—
1275	2180	10.0	—	—	—	—	—	—	—	—
1350	—	—	—	—	—	—	—	—	—	—
1425	—	—	—	—	—	—	—	—	—	—
1500	—	—	—	—	—	—	—	—	—	—

Medium Static 1060-2190 RPM

50FCQA04 SINGLE PHASE - HIGH STATIC — 3 TON VERTICAL SUPPLY (RPM - VDC)

CFM	AVAILABLE EXTERNAL STATIC PRESSURE (in. wg)									
	0.2		0.4		0.6		0.8		1.0	
	RPM	Vdc	RPM	Vdc	RPM	Vdc	RPM	Vdc	RPM	Vdc
900	1060	4.3	1325	5.3	1541	6.2	1718	6.9	1871	7.5
975	1103	4.4	1355	5.4	1572	6.3	1752	7.0	1906	7.7
1050	1150	4.6	1387	5.6	1602	6.4	1784	7.2	1941	7.8
1125	1198	4.8	1422	5.7	1632	6.6	1815	7.3	1974	7.9
1200	1249	5.0	1459	5.9	1662	6.7	1845	7.4	2005	8.1
1275	1303	5.2	1499	6.0	1694	6.8	1874	7.5	2036	8.2
1350	1357	5.4	1542	6.2	1728	6.9	1905	7.7	2066	8.3
1425	1413	5.7	1587	6.4	1765	7.1	1936	7.8	2095	8.4
1500	1469	5.9	1635	6.6	1803	7.2	1969	7.9	2126	8.5

CFM	AVAILABLE EXTERNAL STATIC PRESSURE (in. wg)									
	1.2		1.4		1.6		1.8		2.0	
	RPM	Vdc	RPM	Vdc	RPM	Vdc	RPM	Vdc	RPM	Vdc
900	2006	8.1	2130	8.6	2244	9.0	2352	9.4	2454	9.9
975	2044	8.2	2168	8.7	2283	9.2	2391	9.6	—	—
1050	2080	8.4	2206	8.9	2322	9.3	2430	9.8	—	—
1125	2115	8.5	2242	9.0	2359	9.5	2468	9.9	—	—
1200	2148	8.6	2277	9.1	2396	9.6	—	—	—	—
1275	2180	8.8	2311	9.3	2431	9.8	—	—	—	—
1350	2211	8.9	2343	9.4	2465	9.9	—	—	—	—
1425	2241	9.0	2375	9.5	—	—	—	—	—	—
1500	2271	9.1	2405	9.7	—	—	—	—	—	—

High Static 1060-2490 RPM

50FCQA04 THREE PHASE — 3 TON VERTICAL SUPPLY (RPM - BHP)

CFM	AVAILABLE EXTERNAL STATIC PRESSURE (in. wg)									
	0.2		0.4		0.6		0.8		1.0	
	RPM	BHP	RPM	BHP	RPM	BHP	RPM	BHP	RPM	BHP
900	1060	0.08	1325	0.16	1541	0.25	1718	0.35	1871	0.46
975	1103	0.09	1355	0.17	1572	0.27	1752	0.37	1906	0.48
1050	1150	0.11	1387	0.19	1602	0.29	1784	0.40	1941	0.51
1125	1198	0.12	1422	0.20	1632	0.30	1815	0.42	1974	0.54
1200	1249	0.14	1460	0.22	1662	0.32	1845	0.44	2005	0.56
1275	1303	0.15	1499	0.23	1694	0.34	1874	0.46	2036	0.59
1350	1357	0.17	1542	0.26	1728	0.36	1905	0.48	2066	0.61
1425	1413	0.20	1587	0.28	1765	0.38	1936	0.51	2095	0.64
1500	1469	0.22	1635	0.30	1803	0.41	1969	0.53	2126	0.67

CFM	AVAILABLE EXTERNAL STATIC PRESSURE (in. wg)									
	1.2		1.4		1.6		1.8		2.0	
	RPM	BHP	RPM	BHP	RPM	BHP	RPM	BHP	RPM	BHP
900	2006	0.56	2130	0.67	2245	0.79	2352	0.91	2454	1.03
975	2044	0.59	2169	0.71	2284	0.83	2391	0.95	—	—
1050	2080	0.63	2206	0.75	2322	0.87	2430	1.00	—	—
1125	2115	0.66	2242	0.78	2360	0.92	2469	1.05	—	—
1200	2148	0.69	2277	0.82	2396	0.96	—	—	—	—
1275	2180	0.72	2311	0.86	2431	1.00	—	—	—	—
1350	2211	0.75	2343	0.90	2465	1.04	—	—	—	—
1425	2241	0.78	2375	0.93	—	—	—	—	—	—
1500	2271	0.82	2405	0.97	—	—	—	—	—	—

Standard Static 1060-1890 RPM, 0.44 Max BHP

Medium Static 1060-2190 RPM, 0.71 Max BHP

High Static 1060-2490 RPM, 1.07 Max BHP

50FCQA04 THREE PHASE - STANDARD STATIC — 3 TON VERTICAL SUPPLY (RPM - VDC)

CFM	AVAILABLE EXTERNAL STATIC PRESSURE (in. wg)									
	0.2		0.4		0.6		0.8		1.0	
	RPM	Vdc	RPM	Vdc	RPM	Vdc	RPM	Vdc	RPM	Vdc
900	1060	5.6	1325	7.0	1541	8.2	1718	9.1	1871	9.9
975	1103	5.8	1355	7.2	1572	8.3	1752	9.3	—	—
1050	1150	6.1	1387	7.3	1602	8.5	1784	9.4	—	—
1125	1198	6.3	1422	7.5	1632	8.6	1815	9.6	—	—
1200	1249	6.6	1460	7.7	1662	8.8	1845	9.8	—	—
1275	1303	6.9	1499	7.9	1694	9.0	1874	9.9	—	—
1350	1357	7.2	1542	8.2	1728	9.1	—	—	—	—
1425	1413	7.5	1587	8.4	1765	9.3	—	—	—	—
1500	1469	7.8	1635	8.7	1803	9.5	—	—	—	—

CFM	AVAILABLE EXTERNAL STATIC PRESSURE (in. wg)									
	1.2		1.4		1.6		1.8		2.0	
	RPM	Vdc	RPM	Vdc	RPM	Vdc	RPM	Vdc	RPM	Vdc
900	—	—	—	—	—	—	—	—	—	—
975	—	—	—	—	—	—	—	—	—	—
1050	—	—	—	—	—	—	—	—	—	—
1125	—	—	—	—	—	—	—	—	—	—
1200	—	—	—	—	—	—	—	—	—	—
1275	—	—	—	—	—	—	—	—	—	—
1350	—	—	—	—	—	—	—	—	—	—
1425	—	—	—	—	—	—	—	—	—	—
1500	—	—	—	—	—	—	—	—	—	—

Standard Static 1060-1890 RPM



50FCQA04 THREE PHASE - MEDIUM STATIC — 3 TON VERTICAL SUPPLY (RPM - VDC)

CFM	AVAILABLE EXTERNAL STATIC PRESSURE (in. wg)									
	0.2		0.4		0.6		0.8		1.0	
	RPM	Vdc	RPM	Vdc	RPM	Vdc	RPM	Vdc	RPM	Vdc
900	1060	4.8	1325	6.1	1541	7.0	1718	7.8	1871	8.5
975	1103	5.0	1355	6.2	1572	7.2	1752	8.0	1906	8.7
1050	1150	5.3	1387	6.3	1602	7.3	1784	8.1	1941	8.9
1125	1198	5.5	1422	6.5	1632	7.5	1815	8.3	1974	9.0
1200	1249	5.7	1460	6.7	1662	7.6	1845	8.4	2005	9.2
1275	1303	5.9	1499	6.8	1694	7.7	1874	8.6	2036	9.3
1350	1357	6.2	1542	7.0	1728	7.9	1905	8.7	2066	9.4
1425	1413	6.5	1587	7.2	1765	8.1	1936	8.8	2095	9.6
1500	1469	6.7	1635	7.5	1803	8.2	1969	9.0	2126	9.7

CFM	AVAILABLE EXTERNAL STATIC PRESSURE (in. wg)									
	1.2		1.4		1.6		1.8		2.0	
	RPM	Vdc	RPM	Vdc	RPM	Vdc	RPM	Vdc	RPM	Vdc
900	2006	9.2	2130	9.7	—	—	—	—	—	—
975	2044	9.3	2169	9.9	—	—	—	—	—	—
1050	2080	9.5	—	—	—	—	—	—	—	—
1125	2115	9.7	—	—	—	—	—	—	—	—
1200	2148	9.8	—	—	—	—	—	—	—	—
1275	2180	10.0	—	—	—	—	—	—	—	—
1350	—	—	—	—	—	—	—	—	—	—
1425	—	—	—	—	—	—	—	—	—	—
1500	—	—	—	—	—	—	—	—	—	—

Medium Static 1060-2190 RPM

50FCQA04 THREE PHASE - HIGH STATIC — 3 TON VERTICAL SUPPLY (RPM - VDC)

CFM	AVAILABLE EXTERNAL STATIC PRESSURE (in. wg)									
	0.2		0.4		0.6		0.8		1.0	
	RPM	Vdc	RPM	Vdc	RPM	Vdc	RPM	Vdc	RPM	Vdc
900	1060	4.3	1325	5.3	1541	6.2	1718	6.9	1871	7.5
975	1103	4.4	1355	5.4	1572	6.3	1752	7.0	1906	7.7
1050	1150	4.6	1387	5.6	1602	6.4	1784	7.2	1941	7.8
1125	1198	4.8	1422	5.7	1632	6.6	1815	7.3	1974	7.9
1200	1249	5.0	1460	5.9	1662	6.7	1845	7.4	2005	8.1
1275	1303	5.2	1499	6.0	1694	6.8	1874	7.5	2036	8.2
1350	1357	5.4	1542	6.2	1728	6.9	1905	7.7	2066	8.3
1425	1413	5.7	1587	6.4	1765	7.1	1936	7.8	2095	8.4
1500	1469	5.9	1635	6.6	1803	7.2	1969	7.9	2126	8.5

CFM	AVAILABLE EXTERNAL STATIC PRESSURE (in. wg)									
	1.2		1.4		1.6		1.8		2.0	
	RPM	Vdc	RPM	Vdc	RPM	Vdc	RPM	Vdc	RPM	Vdc
900	2006	8.1	2130	8.6	2245	9.0	2352	9.4	2454	9.9
975	2044	8.2	2169	8.7	2284	9.2	2391	9.6	—	—
1050	2080	8.4	2206	8.9	2322	9.3	2430	9.8	—	—
1125	2115	8.5	2242	9.0	2360	9.5	2469	9.9	—	—
1200	2148	8.6	2277	9.1	2396	9.6	—	—	—	—
1275	2180	8.8	2311	9.3	2431	9.8	—	—	—	—
1350	2211	8.9	2343	9.4	2465	9.9	—	—	—	—
1425	2241	9.0	2375	9.5	—	—	—	—	—	—
1500	2271	9.1	2405	9.7	—	—	—	—	—	—

High Static 1060-2490 RPM

50FCQA05 SINGLE PHASE — 4 TON VERTICAL SUPPLY (RPM - BHP)

CFM	AVAILABLE EXTERNAL STATIC PRESSURE (in. wg)									
	0.2		0.4		0.6		0.8		1.0	
	RPM	BHP	RPM	BHP	RPM	BHP	RPM	BHP	RPM	BHP
1200	1095	0.14	1302	0.24	1484	0.35	1646	0.48	1794	0.63
1300	1151	0.16	1347	0.26	1523	0.38	1681	0.51	1826	0.66
1400	1209	0.19	1395	0.29	1565	0.41	1719	0.55	1860	0.69
1500	1269	0.22	1444	0.32	1608	0.45	1758	0.58	1897	0.73
1600	1331	0.25	1496	0.36	1654	0.48	1800	0.62	1935	0.78
1700	1396	0.29	1550	0.40	1701	0.53	1843	0.67	1975	0.82
1800	1462	0.33	1605	0.44	1750	0.57	1888	0.72	2017	0.87
1900	1528	0.38	1663	0.49	1801	0.62	1934	0.77	2060	0.93
2000	1596	0.43	1722	0.54	1854	0.68	1982	0.83	2105	0.99

CFM	AVAILABLE EXTERNAL STATIC PRESSURE (in. wg)									
	1.2		1.4		1.6		1.8		2.0	
	RPM	BHP	RPM	BHP	RPM	BHP	RPM	BHP	RPM	BHP
1200	1931	0.78	2058	0.95	2177	1.12	2288	1.30	2394	1.49
1300	1961	0.82	2086	0.98	2205	1.16	2316	1.34	2422	1.54
1400	1993	0.85	2116	1.02	2233	1.20	2344	1.39	2450	1.58
1500	2026	0.89	2148	1.06	2264	1.25	2373	1.44	—	—
1600	2062	0.94	2181	1.11	2296	1.30	2404	1.49	—	—
1700	2099	0.99	2217	1.16	2328	1.35	2435	1.54	—	—
1800	2138	1.04	2254	1.22	2363	1.41	—	—	—	—
1900	2179	1.10	2292	1.28	2400	1.47	—	—	—	—
2000	2221	1.16	2332	1.34	2438	1.54	—	—	—	—

Standard Static 1095-1900 RPM, 0.72 Max BHP

Medium Static 1095-2170 RPM, 1.06 Max BHP

High Static 1095-2460 RPM, 1.53 Max BHP

50FCQA05 SINGLE PHASE - STANDARD STATIC — 4 TON VERTICAL SUPPLY (RPM - VDC)

CFM	AVAILABLE EXTERNAL STATIC PRESSURE (in. wg)									
	0.2		0.4		0.6		0.8		1.0	
	RPM	Vdc	RPM	Vdc	RPM	Vdc	RPM	Vdc	RPM	Vdc
1200	1094	5.8	1302	6.9	1484	7.8	1646	8.7	1794	9.4
1300	1150	6.1	1347	7.1	1523	8.0	1681	8.8	1826	9.6
1400	1209	6.4	1395	7.3	1565	8.2	1719	9.0	1860	9.8
1500	1269	6.7	1444	7.6	1608	8.5	1758	9.3	1897	10.0
1600	1332	7.0	1496	7.9	1654	8.7	1800	9.5	—	—
1700	1396	7.3	1549	8.2	1701	9.0	1843	9.7	—	—
1800	1461	7.7	1605	8.4	1750	9.2	1888	9.9	—	—
1900	1528	8.0	1662	8.7	1801	9.5	—	—	—	—
2000	1596	8.4	1721	9.1	1853	9.8	—	—	—	—

CFM	AVAILABLE EXTERNAL STATIC PRESSURE (in. wg)									
	1.2		1.4		1.6		1.8		2.0	
	RPM	Vdc	RPM	Vdc	RPM	Vdc	RPM	Vdc	RPM	Vdc
1200	—	—	—	—	—	—	—	—	—	—
1300	—	—	—	—	—	—	—	—	—	—
1400	—	—	—	—	—	—	—	—	—	—
1500	—	—	—	—	—	—	—	—	—	—
1600	—	—	—	—	—	—	—	—	—	—
1700	—	—	—	—	—	—	—	—	—	—
1800	—	—	—	—	—	—	—	—	—	—
1900	—	—	—	—	—	—	—	—	—	—
2000	—	—	—	—	—	—	—	—	—	—

Standard Static 1094-1900 RPM



50FCQA05 SINGLE PHASE - MEDIUM STATIC — 4 TON VERTICAL SUPPLY (RPM - VDC)

CFM	AVAILABLE EXTERNAL STATIC PRESSURE (in. wg)									
	0.2		0.4		0.6		0.8		1.0	
	RPM	Vdc	RPM	Vdc	RPM	Vdc	RPM	Vdc	RPM	Vdc
1200	1094	5.0	1302	6.0	1484	6.8	1646	7.6	1794	8.3
1300	1150	5.3	1347	6.2	1523	7.0	1681	7.7	1826	8.4
1400	1209	5.6	1395	6.4	1565	7.2	1719	7.9	1860	8.6
1500	1269	5.8	1444	6.7	1608	7.4	1758	8.1	1897	8.7
1600	1332	6.1	1496	6.9	1654	7.6	1800	8.3	1935	8.9
1700	1396	6.4	1549	7.1	1701	7.8	1843	8.5	1975	9.1
1800	1461	6.7	1605	7.4	1750	8.1	1888	8.7	2017	9.3
1900	1528	7.0	1662	7.7	1801	8.3	1934	8.9	2060	9.5
2000	1596	7.4	1721	7.9	1853	8.5	1982	9.1	2105	9.7

CFM	AVAILABLE EXTERNAL STATIC PRESSURE (in. wg)									
	1.2		1.4		1.6		1.8		2.0	
	RPM	Vdc	RPM	Vdc	RPM	Vdc	RPM	Vdc	RPM	Vdc
1200	1930	8.9	2058	9.5	—	—	—	—	—	—
1300	1960	9.0	2086	9.6	—	—	—	—	—	—
1400	1992	9.2	2116	9.8	—	—	—	—	—	—
1500	2026	9.3	2148	9.9	—	—	—	—	—	—
1600	2062	9.5	—	—	—	—	—	—	—	—
1700	2099	9.7	—	—	—	—	—	—	—	—
1800	2138	9.9	—	—	—	—	—	—	—	—
1900	—	—	—	—	—	—	—	—	—	—
2000	—	—	—	—	—	—	—	—	—	—

Medium Static 1094-2170 RPM

50FCQA05 SINGLE PHASE — HIGH STATIC — 4 TON VERTICAL SUPPLY (RPM - VDC)

CFM	AVAILABLE EXTERNAL STATIC PRESSURE (in. wg)									
	0.2		0.4		0.6		0.8		1.0	
	RPM	Vdc	RPM	Vdc	RPM	Vdc	RPM	Vdc	RPM	Vdc
1200	1094	4.4	1302	5.3	1484	6.0	1646	6.7	1794	7.3
1300	1150	4.7	1347	5.5	1523	6.2	1681	6.8	1826	7.4
1400	1209	4.9	1395	5.7	1565	6.4	1719	7.0	1860	7.6
1500	1269	5.2	1444	5.9	1608	6.5	1758	7.1	1897	7.7
1600	1332	5.4	1496	6.1	1654	6.7	1800	7.3	1935	7.9
1700	1396	5.7	1549	6.3	1701	6.9	1843	7.5	1975	8.0
1800	1461	5.9	1605	6.5	1750	7.1	1888	7.7	2017	8.2
1900	1528	6.2	1662	6.8	1801	7.3	1934	7.9	2060	8.4
2000	1596	6.5	1721	7.0	1853	7.5	1982	8.1	2105	8.6

CFM	AVAILABLE EXTERNAL STATIC PRESSURE (in. wg)									
	1.2		1.4		1.6		1.8		2.0	
	RPM	Vdc	RPM	Vdc	RPM	Vdc	RPM	Vdc	RPM	Vdc
1200	1930	7.8	2058	8.4	2177	8.8	2288	9.3	2394	9.7
1300	1960	8.0	2086	8.5	2205	9.0	2316	9.4	2422	9.8
1400	1992	8.1	2116	8.6	2233	9.1	2344	9.5	2450	10.0
1500	2026	8.2	2148	8.7	2263	9.2	2373	9.6	—	—
1600	2062	8.4	2181	8.9	2295	9.3	2403	9.8	—	—
1700	2099	8.5	2217	9.0	2328	9.5	2435	9.9	—	—
1800	2138	8.7	2254	9.2	2363	9.6	—	—	—	—
1900	2179	8.9	2292	9.3	2400	9.8	—	—	—	—
2000	2221	9.0	2332	9.5	2438	9.9	—	—	—	—

High Static 1094-2460 RPM

50FCQA05 THREE PHASE — 4 TON VERTICAL SUPPLY (RPM - BHP)

CFM	AVAILABLE EXTERNAL STATIC PRESSURE (in. wg)									
	0.2		0.4		0.6		0.8		1.0	
	RPM	BHP	RPM	BHP	RPM	BHP	RPM	BHP	RPM	BHP
1200	1094	0.14	1302	0.24	1484	0.35	1646	0.48	1794	0.63
1300	1150	0.16	1347	0.26	1524	0.38	1681	0.51	1826	0.66
1400	1209	0.19	1395	0.29	1565	0.41	1719	0.55	1860	0.69
1500	1269	0.22	1444	0.32	1608	0.45	1759	0.58	1897	0.73
1600	1332	0.25	1496	0.36	1654	0.48	1800	0.62	1935	0.78
1700	1396	0.29	1549	0.40	1701	0.53	1843	0.67	1976	0.82
1800	1461	0.33	1605	0.44	1750	0.57	1888	0.72	2017	0.87
1900	1528	0.38	1662	0.49	1801	0.62	1934	0.77	2060	0.93
2000	1596	0.43	1721	0.54	1853	0.67	1982	0.83	2105	0.99

CFM	AVAILABLE EXTERNAL STATIC PRESSURE (in. wg)									
	1.2		1.4		1.6		1.8		2.0	
	RPM	BHP	RPM	BHP	RPM	BHP	RPM	BHP	RPM	BHP
1200	1930	0.78	2058	0.95	2177	1.12	2288	1.30	2394	1.49
1300	1960	0.81	2086	0.98	2205	1.16	2316	1.34	2422	1.54
1400	1992	0.85	2116	1.02	2233	1.20	2344	1.39	2450	1.58
1500	2026	0.89	2148	1.06	2263	1.24	2373	1.44	2478	1.63
1600	2062	0.94	2181	1.11	2295	1.29	2403	1.49	2507	1.69
1700	2099	0.99	2217	1.16	2328	1.35	2435	1.54	2538	1.75
1800	2138	1.04	2254	1.22	2363	1.40	2469	1.60	2570	1.81
1900	2180	1.10	2292	1.28	2400	1.47	2503	1.67	2603	1.87
2000	2222	1.16	2332	1.34	2438	1.54	2540	1.74	2638	1.95

Standard Static 1094-1900 RPM, 0.72 Max BHP

Medium Static 1094-2170 RPM, 1.06 Max BHP

High Static 1094-2660 RPM, 1.96 Max BHP

50FCQA05 THREE PHASE - STANDARD STATIC — 4 TON VERTICAL SUPPLY (RPM - VDC)

CFM	AVAILABLE EXTERNAL STATIC PRESSURE (in. wg)									
	0.2		0.4		0.6		0.8		1.0	
	RPM	Vdc	RPM	Vdc	RPM	Vdc	RPM	Vdc	RPM	Vdc
1200	1094	5.8	1302	6.9	1484	7.8	1646	8.7	1794	9.4
1300	1150	6.1	1347	7.1	1524	8.0	1681	8.8	1826	9.6
1400	1209	6.4	1395	7.3	1565	8.2	1719	9.0	1860	9.8
1500	1269	6.7	1444	7.6	1608	8.5	1759	9.3	1897	10.0
1600	1332	7.0	1496	7.9	1654	8.7	1800	9.5	—	—
1700	1396	7.3	1549	8.2	1701	9.0	1843	9.7	—	—
1800	1461	7.7	1605	8.4	1750	9.2	1888	9.9	—	—
1900	1528	8.0	1662	8.7	1801	9.5	—	—	—	—
2000	1596	8.4	1721	9.1	1853	9.8	—	—	—	—

CFM	AVAILABLE EXTERNAL STATIC PRESSURE (in. wg)									
	1.2		1.4		1.6		1.8		2.0	
	RPM	Vdc	RPM	Vdc	RPM	Vdc	RPM	Vdc	RPM	Vdc
1200	—	—	—	—	—	—	—	—	—	—
1300	—	—	—	—	—	—	—	—	—	—
1400	—	—	—	—	—	—	—	—	—	—
1500	—	—	—	—	—	—	—	—	—	—
1600	—	—	—	—	—	—	—	—	—	—
1700	—	—	—	—	—	—	—	—	—	—
1800	—	—	—	—	—	—	—	—	—	—
1900	—	—	—	—	—	—	—	—	—	—
2000	—	—	—	—	—	—	—	—	—	—

Standard Static 1094-1900 RPM



50FCQA05 THREE PHASE - MEDIUM STATIC — 4 TON VERTICAL SUPPLY (RPM - VDC)

CFM	AVAILABLE EXTERNAL STATIC PRESSURE (in. wg)									
	0.2		0.4		0.6		0.8		1.0	
	RPM	Vdc	RPM	Vdc	RPM	Vdc	RPM	Vdc	RPM	Vdc
1200	1094	5.0	1302	6.0	1484	6.8	1646	7.6	1794	8.3
1300	1150	5.3	1347	6.2	1524	7.0	1681	7.7	1826	8.4
1400	1209	5.6	1395	6.4	1565	7.2	1719	7.9	1860	8.6
1500	1269	5.8	1444	6.7	1608	7.4	1759	8.1	1897	8.7
1600	1332	6.1	1496	6.9	1654	7.6	1800	8.3	1935	8.9
1700	1396	6.4	1549	7.1	1701	7.8	1843	8.5	1976	9.1
1800	1461	6.7	1605	7.4	1750	8.1	1888	8.7	2017	9.3
1900	1528	7.0	1662	7.7	1801	8.3	1934	8.9	2060	9.5
2000	1596	7.4	1721	7.9	1853	8.5	1982	9.1	2105	9.7

CFM	AVAILABLE EXTERNAL STATIC PRESSURE (in. wg)									
	1.2		1.4		1.6		1.8		2.0	
	RPM	Vdc	RPM	Vdc	RPM	Vdc	RPM	Vdc	RPM	Vdc
1200	1930	8.9	2058	9.5	—	—	—	—	—	—
1300	1960	9.0	2086	9.6	—	—	—	—	—	—
1400	1992	9.2	2116	9.8	—	—	—	—	—	—
1500	2026	9.3	2148	9.9	—	—	—	—	—	—
1600	2062	9.5	—	—	—	—	—	—	—	—
1700	2099	9.7	—	—	—	—	—	—	—	—
1800	2138	9.9	—	—	—	—	—	—	—	—
1900	—	—	—	—	—	—	—	—	—	—
2000	—	—	—	—	—	—	—	—	—	—

Medium Static 1094-2170 RPM

50FCQA05 THREE PHASE - HIGH STATIC — 4 TON VERTICAL SUPPLY (RPM - VDC)

CFM	AVAILABLE EXTERNAL STATIC PRESSURE (in. wg)									
	0.2		0.4		0.6		0.8		1.0	
	RPM	Vdc	RPM	Vdc	RPM	Vdc	RPM	Vdc	RPM	Vdc
1200	1094	4.1	1302	4.9	1484	5.6	1646	6.2	1794	6.7
1300	1150	4.3	1347	5.1	1524	5.7	1681	6.3	1826	6.9
1400	1209	4.5	1395	5.2	1565	5.9	1719	6.5	1860	7.0
1500	1269	4.8	1444	5.4	1608	6.0	1759	6.6	1897	7.1
1600	1332	5.0	1496	5.6	1654	6.2	1800	6.8	1935	7.3
1700	1396	5.2	1549	5.8	1701	6.4	1843	6.9	1976	7.4
1800	1461	5.5	1605	6.0	1750	6.6	1888	7.1	2017	7.6
1900	1528	5.7	1662	6.2	1801	6.8	1934	7.3	2060	7.7
2000	1596	6.0	1721	6.5	1853	7.0	1982	7.5	2105	7.9

CFM	AVAILABLE EXTERNAL STATIC PRESSURE (in. wg)									
	1.2		1.4		1.6		1.8		2.0	
	RPM	Vdc	RPM	Vdc	RPM	Vdc	RPM	Vdc	RPM	Vdc
1200	1930	7.3	2058	7.7	2177	8.2	2288	8.6	2394	9.0
1300	1960	7.4	2086	7.8	2205	8.3	2316	8.7	2422	9.1
1400	1992	7.5	2116	8.0	2233	8.4	2344	8.8	2450	9.2
1500	2026	7.6	2148	8.1	2263	8.5	2373	8.9	2478	9.3
1600	2062	7.8	2181	8.2	2295	8.6	2403	9.0	2507	9.4
1700	2099	7.9	2217	8.3	2328	8.8	2435	9.2	2538	9.5
1800	2138	8.0	2254	8.5	2363	8.9	2469	9.3	2570	9.7
1900	2180	8.2	2292	8.6	2400	9.0	2503	9.4	2603	9.8
2000	2222	8.4	2332	8.8	2438	9.2	2540	9.5	2638	9.9

High Static 1094-2660 RPM

50FCQA06 SINGLE PHASE — 5 TON VERTICAL SUPPLY (RPM - BHP)

CFM	AVAILABLE EXTERNAL STATIC PRESSURE (in. wg)									
	0.2		0.4		0.6		0.8		1.0	
	RPM	BHP	RPM	BHP	RPM	BHP	RPM	BHP	RPM	BHP
1500	1228	0.20	1394	0.29	1554	0.40	1701	0.53	1836	0.66
1625	1305	0.24	1457	0.33	1609	0.44	1750	0.57	1882	0.71
1750	1384	0.28	1523	0.37	1666	0.49	1802	0.62	1930	0.76
1875	1466	0.33	1592	0.43	1726	0.54	1857	0.67	1981	0.82
2000	1549	0.39	1664	0.48	1789	0.60	1914	0.74	2034	0.88
2125	1633	0.46	1739	0.55	1855	0.67	1974	0.81	2089	0.95
2250	1718	0.53	1816	0.63	1924	0.74	2036	0.88	2146	1.03
2375	1803	0.61	1894	0.71	1995	0.83	2100	0.97	2206	1.12
2500	1890	0.70	1974	0.80	2068	0.92	2167	1.06	2268	1.21

CFM	AVAILABLE EXTERNAL STATIC PRESSURE (in. wg)									
	1.2		1.4		1.6		1.8		2.0	
	RPM	BHP	RPM	BHP	RPM	BHP	RPM	BHP	RPM	BHP
1500	1961	0.80	2079	0.96	2191	1.12	2297	1.29	2399	1.47
1625	2004	0.85	2120	1.01	2229	1.18	2334	1.35	2434	1.53
1750	2050	0.91	2163	1.07	2270	1.24	2373	1.41	2472	1.60
1875	2098	0.97	2208	1.13	2314	1.31	2414	1.48	2511	1.67
2000	2148	1.04	2256	1.21	2359	1.38	2458	1.56	2553	1.75
2125	2200	1.11	2305	1.28	2407	1.46	2504	1.64	2597	1.83
2250	2254	1.20	2357	1.37	2456	1.55	2551	1.73	2643	1.93
2375	2310	1.28	2410	1.46	2507	1.64	2600	1.83	—	—
2500	2368	1.38	2465	1.56	2560	1.75	2651	1.94	—	—

Standard Static 1228-2150 RPM, 1.06 Max BHP

Medium Static 1228-2390 RPM, 1.44 Max BHP

High Static 1228-2660 RPM, 1.96 Max BHP

50FCQA06 SINGLE PHASE - STANDARD STATIC — 5 TON VERTICAL SUPPLY (RPM - VDC)

CFM	AVAILABLE EXTERNAL STATIC PRESSURE (in. wg)									
	0.2		0.4		0.6		0.8		1.0	
	RPM	Vdc	RPM	Vdc	RPM	Vdc	RPM	Vdc	RPM	Vdc
1500	1228	5.7	1394	6.5	1554	7.2	1701	7.9	1836	8.5
1625	1305	6.1	1457	6.8	1609	7.5	1750	8.1	1882	8.8
1750	1384	6.4	1523	7.1	1666	7.7	1802	8.4	1930	9.0
1875	1466	6.8	1592	7.4	1726	8.0	1857	8.6	1981	9.2
2000	1549	7.2	1664	7.7	1789	8.3	1914	8.9	2034	9.5
2125	1633	7.6	1739	8.1	1855	8.6	1974	9.2	2089	9.7
2250	1718	8.0	1816	8.4	1924	8.9	2036	9.5	2146	10.0
2375	1803	8.4	1894	8.8	1995	9.3	2100	9.8	—	—
2500	1890	8.8	1974	9.2	2068	9.6	—	—	—	—

CFM	AVAILABLE EXTERNAL STATIC PRESSURE (in. wg)									
	1.2		1.4		1.6		1.8		2.0	
	RPM	Vdc	RPM	Vdc	RPM	Vdc	RPM	Vdc	RPM	Vdc
1500	1961	9.1	2079	9.7	—	—	—	—	—	—
1625	2004	9.3	2120	9.9	—	—	—	—	—	—
1750	2050	9.5	—	—	—	—	—	—	—	—
1875	2098	9.8	—	—	—	—	—	—	—	—
2000	2148	10.0	—	—	—	—	—	—	—	—
2125	—	—	—	—	—	—	—	—	—	—
2250	—	—	—	—	—	—	—	—	—	—
2375	—	—	—	—	—	—	—	—	—	—
2500	—	—	—	—	—	—	—	—	—	—

Standard Static 1228-2150 RPM

50FCQA06 SINGLE PHASE - MEDIUM STATIC — 5 TON VERTICAL SUPPLY (RPM - VDC)

CFM	AVAILABLE EXTERNAL STATIC PRESSURE (in. wg)									
	0.2		0.4		0.6		0.8		1.0	
	RPM	Vdc	RPM	Vdc	RPM	Vdc	RPM	Vdc	RPM	Vdc
1500	1228	5.1	1394	5.8	1554	6.5	1701	7.1	1836	7.7
1625	1305	5.5	1457	6.1	1609	6.7	1750	7.3	1882	7.9
1750	1384	5.8	1523	6.4	1666	7.0	1802	7.5	1930	8.1
1875	1466	6.1	1592	6.7	1726	7.2	1857	7.8	1981	8.3
2000	1549	6.5	1664	7.0	1789	7.5	1914	8.0	2034	8.5
2125	1633	6.8	1739	7.3	1855	7.8	1974	8.3	2089	8.7
2250	1718	7.2	1816	7.6	1924	8.1	2036	8.5	2146	9.0
2375	1803	7.5	1894	7.9	1995	8.3	2100	8.8	2206	9.2
2500	1890	7.9	1974	8.3	2068	8.7	2167	9.1	2268	9.5

CFM	AVAILABLE EXTERNAL STATIC PRESSURE (in. wg)									
	1.2		1.4		1.6		1.8		2.0	
	RPM	Vdc	RPM	Vdc	RPM	Vdc	RPM	Vdc	RPM	Vdc
1500	1961	8.2	2079	8.7	2191	9.2	2297	9.6	—	—
1625	2004	8.4	2120	8.9	2229	9.3	2334	9.8	—	—
1750	2050	8.6	2163	9.1	2270	9.5	2373	9.9	—	—
1875	2098	8.8	2208	9.2	2314	9.7	—	—	—	—
2000	2148	9.0	2256	9.4	2359	9.9	—	—	—	—
2125	2200	9.2	2305	9.6	—	—	—	—	—	—
2250	2254	9.4	2357	9.9	—	—	—	—	—	—
2375	2310	9.7	—	—	—	—	—	—	—	—
2500	2368	9.9	—	—	—	—	—	—	—	—

Medium Static 1228-2390 RPM

50FCQA06 SINGLE PHASE - HIGH STATIC — 5 TON VERTICAL SUPPLY (RPM - VDC)

CFM	AVAILABLE EXTERNAL STATIC PRESSURE (in. wg)									
	0.2		0.4		0.6		0.8		1.0	
	RPM	Vdc	RPM	Vdc	RPM	Vdc	RPM	Vdc	RPM	Vdc
1500	1228	4.6	1394	5.2	1554	5.8	1701	6.4	1836	6.9
1625	1305	4.9	1457	5.5	1609	6.0	1750	6.6	1882	7.1
1750	1384	5.2	1523	5.7	1666	6.3	1802	6.8	1930	7.3
1875	1466	5.5	1592	6.0	1726	6.5	1857	7.0	1981	7.4
2000	1549	5.8	1664	6.3	1789	6.7	1914	7.2	2034	7.6
2125	1633	6.1	1739	6.5	1855	7.0	1974	7.4	2089	7.9
2250	1718	6.5	1816	6.8	1924	7.2	2036	7.7	2146	8.1
2375	1803	6.8	1894	7.1	1995	7.5	2100	7.9	2206	8.3
2500	1890	7.1	1974	7.4	2068	7.8	2167	8.1	2268	8.5

CFM	AVAILABLE EXTERNAL STATIC PRESSURE (in. wg)									
	1.2		1.4		1.6		1.8		2.0	
	RPM	Vdc	RPM	Vdc	RPM	Vdc	RPM	Vdc	RPM	Vdc
1500	1961	7.4	2079	7.8	2191	8.2	2297	8.6	2399	9.0
1625	2004	7.5	2120	8.0	2229	8.4	2334	8.8	2434	9.2
1750	2050	7.7	2163	8.1	2270	8.5	2373	8.9	2472	9.3
1875	2098	7.9	2208	8.3	2314	8.7	2414	9.1	2511	9.4
2000	2148	8.1	2256	8.5	2359	8.9	2458	9.2	2553	9.6
2125	2200	8.3	2305	8.7	2407	9.0	2504	9.4	2597	9.8
2250	2254	8.5	2357	8.9	2456	9.2	2551	9.6	2643	9.9
2375	2310	8.7	2410	9.1	2507	9.4	2600	9.8	—	—
2500	2368	8.9	2465	9.3	2560	9.6	2651	10.0	—	—

High Static 1228-2660 RPM

50FCQA06 THREE PHASE — 5 TON VERTICAL SUPPLY (RPM - BHP)

CFM	AVAILABLE EXTERNAL STATIC PRESSURE (in. wg)									
	0.2		0.4		0.6		0.8		1.0	
	RPM	BHP	RPM	BHP	RPM	BHP	RPM	BHP	RPM	BHP
1500	1228	0.20	1394	0.29	1554	0.40	1701	0.53	1836	0.66
1625	1305	0.24	1457	0.33	1609	0.44	1750	0.57	1882	0.71
1750	1384	0.28	1523	0.37	1666	0.49	1802	0.62	1930	0.76
1875	1466	0.33	1592	0.43	1726	0.54	1857	0.67	1981	0.82
2000	1549	0.39	1664	0.48	1789	0.60	1914	0.74	2034	0.88
2125	1633	0.46	1739	0.55	1855	0.67	1974	0.81	2089	0.95
2250	1718	0.53	1816	0.63	1924	0.74	2036	0.88	2146	1.03
2375	1803	0.61	1894	0.71	1995	0.83	2100	0.97	2206	1.12
2500	1889	0.70	1974	0.80	2068	0.92	2167	1.06	2268	1.21

CFM	AVAILABLE EXTERNAL STATIC PRESSURE (in. wg)									
	1.2		1.4		1.6		1.8		2.0	
	RPM	BHP	RPM	BHP	RPM	BHP	RPM	BHP	RPM	BHP
1500	1961	0.80	2079	0.96	2191	1.12	2297	1.29	2399	1.47
1625	2004	0.85	2120	1.01	2229	1.18	2334	1.35	2434	1.53
1750	2050	0.91	2163	1.07	2271	1.24	2373	1.41	2472	1.60
1875	2098	0.97	2208	1.13	2314	1.31	2415	1.48	2511	1.67
2000	2148	1.04	2256	1.21	2359	1.38	2458	1.56	2553	1.75
2125	2200	1.11	2305	1.28	2407	1.46	2504	1.64	2597	1.83
2250	2254	1.20	2357	1.37	2456	1.55	2551	1.73	2643	1.93
2375	2310	1.28	2410	1.46	2507	1.64	2600	1.83	2690	2.03
2500	2368	1.38	2465	1.56	2560	1.75	2651	1.94	2739	2.14

Standard Static 1228-2150 RPM, 1.06 Max BHP

Medium Static 1228-2390 RPM, 1.44 Max BHP

High Static 1228-2836 RPM, 2.43 Max BHP

50FCQA06 THREE PHASE - STANDARD STATIC — 5 TON VERTICAL SUPPLY (RPM - VDC)

CFM	AVAILABLE EXTERNAL STATIC PRESSURE (in. wg)									
	0.2		0.4		0.6		0.8		1.0	
	RPM	Vdc	RPM	Vdc	RPM	Vdc	RPM	Vdc	RPM	Vdc
1500	1228	5.7	1394	6.5	1554	7.2	1701	7.9	1836	8.5
1625	1305	6.1	1457	6.8	1609	7.5	1750	8.1	1882	8.8
1750	1384	6.4	1523	7.1	1666	7.7	1802	8.4	1930	9.0
1875	1466	6.8	1592	7.4	1726	8.0	1857	8.6	1981	9.2
2000	1549	7.2	1664	7.7	1789	8.3	1914	8.9	2034	9.5
2125	1633	7.6	1739	8.1	1855	8.6	1974	9.2	2089	9.7
2250	1718	8.0	1816	8.4	1924	8.9	2036	9.5	2146	10.0
2375	1803	8.4	1894	8.8	1995	9.3	2100	9.8	—	—
2500	1889	8.8	1974	9.2	2068	9.6	—	—	—	—

CFM	AVAILABLE EXTERNAL STATIC PRESSURE (in. wg)									
	1.2		1.4		1.6		1.8		2.0	
	RPM	Vdc	RPM	Vdc	RPM	Vdc	RPM	Vdc	RPM	Vdc
1500	1961	9.1	2079	9.7	—	—	—	—	—	—
1625	2004	9.3	2120	9.9	—	—	—	—	—	—
1750	2050	9.5	—	—	—	—	—	—	—	—
1875	2098	9.8	—	—	—	—	—	—	—	—
2000	2148	10.0	—	—	—	—	—	—	—	—
2125	—	—	—	—	—	—	—	—	—	—
2250	—	—	—	—	—	—	—	—	—	—
2375	—	—	—	—	—	—	—	—	—	—
2500	—	—	—	—	—	—	—	—	—	—

Standard Static 1228-2150 RPM



50FCQA06 THREE PHASE - MEDIUM STATIC — 5 TON VERTICAL SUPPLY (RPM - VDC)

CFM	AVAILABLE EXTERNAL STATIC PRESSURE (in. wg)									
	0.2		0.4		0.6		0.8		1.0	
	RPM	Vdc	RPM	Vdc	RPM	Vdc	RPM	Vdc	RPM	Vdc
1500	1228	5.1	1394	5.8	1554	6.5	1701	7.1	1836	7.7
1625	1305	5.5	1457	6.1	1609	6.7	1750	7.3	1882	7.9
1750	1384	5.8	1523	6.4	1666	7.0	1802	7.5	1930	8.1
1875	1466	6.1	1592	6.7	1726	7.2	1857	7.8	1981	8.3
2000	1549	6.5	1664	7.0	1789	7.5	1914	8.0	2034	8.5
2125	1633	6.8	1739	7.3	1855	7.8	1974	8.3	2089	8.7
2250	1718	7.2	1816	7.6	1924	8.1	2036	8.5	2146	9.0
2375	1803	7.5	1894	7.9	1995	8.3	2100	8.8	2206	9.2
2500	1889	7.9	1974	8.3	2068	8.7	2167	9.1	2268	9.5

CFM	AVAILABLE EXTERNAL STATIC PRESSURE (in. wg)									
	1.2		1.4		1.6		1.8		2.0	
	RPM	Vdc	RPM	Vdc	RPM	Vdc	RPM	Vdc	RPM	Vdc
1500	1961	8.2	2079	8.7	2191	9.2	2297	9.6	—	—
1625	2004	8.4	2120	8.9	2229	9.3	2334	9.8	—	—
1750	2050	8.6	2163	9.1	2271	9.5	2373	9.9	—	—
1875	2098	8.8	2208	9.2	2314	9.7	—	—	—	—
2000	2148	9.0	2256	9.4	2359	9.9	—	—	—	—
2125	2200	9.2	2305	9.6	—	—	—	—	—	—
2250	2254	9.4	2357	9.9	—	—	—	—	—	—
2375	2310	9.7	—	—	—	—	—	—	—	—
2500	2368	9.9	—	—	—	—	—	—	—	—

Medium Static 1228-2390 RPM

50FCQA06 THREE PHASE - HIGH STATIC — 5 TON VERTICAL SUPPLY (RPM - VDC)

CFM	AVAILABLE EXTERNAL STATIC PRESSURE (in. wg)									
	0.2		0.4		0.6		0.8		1.0	
	RPM	Vdc	RPM	Vdc	RPM	Vdc	RPM	Vdc	RPM	Vdc
1500	1228	4.3	1394	4.9	1554	5.5	1701	6.0	1836	6.5
1625	1305	4.6	1457	5.1	1609	5.7	1750	6.2	1882	6.6
1750	1384	4.9	1523	5.4	1666	5.9	1802	6.4	1930	6.8
1875	1466	5.2	1592	5.6	1726	6.1	1857	6.5	1981	7.0
2000	1549	5.5	1664	5.9	1789	6.3	1914	6.7	2034	7.2
2125	1633	5.8	1739	6.1	1855	6.5	1974	7.0	2089	7.4
2250	1718	6.1	1816	6.4	1924	6.8	2036	7.2	2146	7.6
2375	1803	6.4	1894	6.7	1995	7.0	2100	7.4	2206	7.8
2500	1889	6.7	1974	7.0	2068	7.3	2167	7.6	2268	8.0

CFM	AVAILABLE EXTERNAL STATIC PRESSURE (in. wg)									
	1.2		1.4		1.6		1.8		2.0	
	RPM	Vdc	RPM	Vdc	RPM	Vdc	RPM	Vdc	RPM	Vdc
1500	1961	6.9	2079	7.3	2191	7.7	2297	8.1	2399	8.5
1625	2004	7.1	2120	7.5	2229	7.9	2334	8.2	2434	8.6
1750	2050	7.2	2163	7.6	2271	8.0	2373	8.4	2472	8.7
1875	2098	7.4	2208	7.8	2314	8.2	2415	8.5	2511	8.9
2000	2148	7.6	2256	8.0	2359	8.3	2458	8.7	2553	9.0
2125	2200	7.8	2305	8.1	2407	8.5	2504	8.8	2597	9.2
2250	2254	7.9	2357	8.3	2456	8.7	2551	9.0	2643	9.3
2375	2310	8.1	2410	8.5	2507	8.8	2600	9.2	2690	9.5
2500	2368	8.3	2465	8.7	2560	9.0	2651	9.3	2739	9.7

High Static 1228-2836 RPM

50FCQM07 THREE PHASE — 6 TON VERTICAL SUPPLY (RPM - BHP)

CFM	AVAILABLE EXTERNAL STATIC PRESSURE (in. wg)									
	0.2		0.4		0.6		0.8		1.0	
	RPM	BHP	RPM	BHP	RPM	BHP	RPM	BHP	RPM	BHP
1800	1416	0.30	1549	0.39	1690	0.51	1824	0.64	1950	0.78
1950	1516	0.37	1635	0.46	1764	0.58	1891	0.71	2012	0.86
2100	1616	0.44	1724	0.54	1841	0.65	1961	0.79	2078	0.94
2250	1718	0.53	1815	0.62	1924	0.74	2036	0.88	2146	1.03
2400	1820	0.63	1910	0.73	2009	0.84	2113	0.98	2218	1.14
2550	1924	0.74	2007	0.84	2098	0.96	2195	1.10	2293	1.25
2700	2028	0.87	2105	0.97	2189	1.09	2279	1.23	2371	1.38
2850	2133	1.01	2205	1.11	2282	1.23	2366	1.37	2453	1.53
3000	2239	1.16	2306	1.27	2378	1.39	2456	1.53	2537	1.69

CFM	AVAILABLE EXTERNAL STATIC PRESSURE (in. wg)									
	1.2		1.4		1.6		1.8		2.0	
	RPM	BHP	RPM	BHP	RPM	BHP	RPM	BHP	RPM	BHP
1800	2069	0.93	2181	1.10	2287	1.26	2389	1.44	2487	1.62
1950	2127	1.01	2237	1.18	2341	1.35	2440	1.53	2536	1.71
2100	2189	1.10	2295	1.27	2397	1.44	2494	1.63	2588	1.82
2250	2254	1.20	2357	1.37	2456	1.55	2551	1.73	2643	1.93
2400	2321	1.30	2421	1.48	2517	1.66	2610	1.85	2700	2.05
2550	2392	1.42	2488	1.60	2581	1.79	2672	1.98	2759	2.18
2700	2465	1.55	2557	1.73	2648	1.93	2736	2.13	2821	2.33
2850	2541	1.70	2630	1.88	2717	2.08	2802	2.28	—	—
3000	2621	1.86	2705	2.05	2788	2.24	—	—	—	—

Standard Static 1416-2300 RPM, 1.31 Max BHP

Medium Static 1416-2530 RPM, 1.76 Max BHP

High Static 1416-2836 RPM, 2.43 Max BHP

50FCQM07 THREE PHASE - STANDARD STATIC — 6 TON VERTICAL SUPPLY (RPM - VDC)

CFM	AVAILABLE EXTERNAL STATIC PRESSURE (in. wg)									
	0.2		0.4		0.6		0.8		1.0	
	RPM	Vdc	RPM	Vdc	RPM	Vdc	RPM	Vdc	RPM	Vdc
1800	1416	6.2	1549	6.7	1690	7.3	1824	7.9	1950	8.5
1950	1516	6.6	1635	7.1	1764	7.7	1891	8.2	2012	8.7
2100	1616	7.0	1724	7.5	1841	8.0	1961	8.5	2078	9.0
2250	1718	7.5	1815	7.9	1924	8.4	2036	8.9	2146	9.3
2400	1820	7.9	1910	8.3	2009	8.7	2113	9.2	2218	9.6
2550	1924	8.4	2007	8.7	2098	9.1	2195	9.5	2293	10.0
2700	2028	8.8	2105	9.2	2189	9.5	2279	9.9	—	—
2850	2133	9.3	2205	9.6	2282	9.9	—	—	—	—
3000	2239	9.7	—	—	—	—	—	—	—	—

CFM	AVAILABLE EXTERNAL STATIC PRESSURE (in. wg)									
	1.2		1.4		1.6		1.8		2.0	
	RPM	Vdc	RPM	Vdc	RPM	Vdc	RPM	Vdc	RPM	Vdc
1800	2069	9.0	2181	9.5	2287	9.9	—	—	—	—
1950	2127	9.2	2237	9.7	—	—	—	—	—	—
2100	2189	9.5	2295	10.0	—	—	—	—	—	—
2250	2254	9.8	—	—	—	—	—	—	—	—
2400	—	—	—	—	—	—	—	—	—	—
2550	—	—	—	—	—	—	—	—	—	—
2700	—	—	—	—	—	—	—	—	—	—
2850	—	—	—	—	—	—	—	—	—	—
3000	—	—	—	—	—	—	—	—	—	—

Standard Static 1416-2300 RPM



50FCQM07 THREE PHASE - MEDIUM STATIC — 6 TON VERTICAL SUPPLY (RPM - VDC)

CFM	AVAILABLE EXTERNAL STATIC PRESSURE (in. wg)									
	0.2		0.4		0.6		0.8		1.0	
	RPM	Vdc	RPM	Vdc	RPM	Vdc	RPM	Vdc	RPM	Vdc
1800	1416	5.6	1549	6.1	1690	6.7	1824	7.2	1950	7.7
1950	1516	6.0	1635	6.5	1764	7.0	1891	7.5	2012	8.0
2100	1616	6.4	1724	6.8	1841	7.3	1961	7.8	2078	8.2
2250	1718	6.8	1815	7.2	1924	7.6	2036	8.0	2146	8.5
2400	1820	7.2	1910	7.5	2009	7.9	2113	8.4	2218	8.8
2550	1924	7.6	2007	7.9	2098	8.3	2195	8.7	2293	9.1
2700	2028	8.0	2105	8.3	2189	8.7	2279	9.0	2371	9.4
2850	2133	8.4	2205	8.7	2282	9.0	2366	9.4	2453	9.7
3000	2239	8.8	2306	9.1	2378	9.4	2456	9.7	—	—

CFM	AVAILABLE EXTERNAL STATIC PRESSURE (in. wg)									
	1.2		1.4		1.6		1.8		2.0	
	RPM	Vdc	RPM	Vdc	RPM	Vdc	RPM	Vdc	RPM	Vdc
1800	2069	8.2	2181	8.6	2287	9.0	2389	9.4	2487	9.8
1950	2127	8.4	2237	8.8	2341	9.3	2440	9.6	—	—
2100	2189	8.7	2295	9.1	2397	9.5	2494	9.9	—	—
2250	2254	8.9	2357	9.3	2456	9.7	—	—	—	—
2400	2321	9.2	2421	9.6	2517	9.9	—	—	—	—
2550	2392	9.5	2488	9.8	—	—	—	—	—	—
2700	2465	9.7	—	—	—	—	—	—	—	—
2850	—	—	—	—	—	—	—	—	—	—
3000	—	—	—	—	—	—	—	—	—	—

Medium Static 1416-2530 RPM

50FCQM07 THREE PHASE - HIGH STATIC — 6 TON VERTICAL SUPPLY (RPM - VDC)

CFM	AVAILABLE EXTERNAL STATIC PRESSURE (in. wg)									
	0.2		0.4		0.6		0.8		1.0	
	RPM	Vdc	RPM	Vdc	RPM	Vdc	RPM	Vdc	RPM	Vdc
1800	1416	5.0	1549	5.5	1690	6.0	1824	6.4	1950	6.9
1950	1516	5.3	1635	5.8	1764	6.2	1891	6.7	2012	7.1
2100	1616	5.7	1724	6.1	1841	6.5	1961	6.9	2078	7.3
2250	1718	6.1	1815	6.4	1924	6.8	2036	7.2	2146	7.6
2400	1820	6.4	1910	6.7	2009	7.1	2113	7.5	2218	7.8
2550	1924	6.8	2007	7.1	2098	7.4	2195	7.7	2293	8.1
2700	2028	7.2	2105	7.4	2189	7.7	2279	8.0	2371	8.4
2850	2133	7.5	2205	7.8	2282	8.0	2366	8.3	2453	8.6
3000	2239	7.9	2306	8.1	2378	8.4	2456	8.7	2537	8.9

CFM	AVAILABLE EXTERNAL STATIC PRESSURE (in. wg)									
	1.2		1.4		1.6		1.8		2.0	
	RPM	Vdc	RPM	Vdc	RPM	Vdc	RPM	Vdc	RPM	Vdc
1800	2069	7.3	2181	7.7	2287	8.1	2389	8.4	2487	8.8
1950	2127	7.5	2237	7.9	2341	8.3	2440	8.6	2536	8.9
2100	2189	7.7	2295	8.1	2397	8.5	2494	8.8	2588	9.1
2250	2254	7.9	2357	8.3	2456	8.7	2551	9.0	2643	9.3
2400	2321	8.2	2421	8.5	2517	8.9	2610	9.2	2700	9.5
2550	2392	8.4	2488	8.8	2581	9.1	2672	9.4	2759	9.7
2700	2465	8.7	2557	9.0	2648	9.3	2736	9.6	2821	9.9
2850	2541	9.0	2630	9.3	2717	9.6	2802	9.9	—	—
3000	2621	9.2	2705	9.5	2788	9.8	—	—	—	—

High Static 1416-2836 RPM

50FCQA04 SINGLE PHASE — 3 TON HORIZONTAL SUPPLY (RPM - BHP)

CFM	AVAILABLE EXTERNAL STATIC PRESSURE (in. wg)									
	0.2		0.4		0.6		0.8		1.0	
	RPM	BHP	RPM	BHP	RPM	BHP	RPM	BHP	RPM	BHP
900	1036	0.08	1301	0.15	1517	0.24	1698	0.34	1855	0.44
975	1077	0.09	1331	0.16	1546	0.26	1727	0.36	1885	0.47
1050	1119	0.10	1362	0.18	1574	0.27	1755	0.38	1915	0.49
1125	1164	0.11	1394	0.19	1603	0.29	1783	0.39	1944	0.51
1200	1211	0.12	1429	0.20	1632	0.30	1813	0.41	1972	0.53
1275	1261	0.14	1466	0.22	1663	0.32	1841	0.43	2000	0.56
1350	1312	0.16	1506	0.24	1695	0.34	1870	0.46	2029	0.58
1425	1365	0.18	1547	0.26	1729	0.36	1901	0.48	2057	0.61
1500	1419	0.20	1591	0.28	1765	0.38	1932	0.50	2087	0.63

CFM	AVAILABLE EXTERNAL STATIC PRESSURE (in. wg)									
	1.2		1.4		1.6		1.8		2.0	
	RPM	BHP	RPM	BHP	RPM	BHP	RPM	BHP	RPM	BHP
900	1996	0.55	2123	0.67	2242	0.78	2352	0.91	2455	1.03
975	2027	0.58	2157	0.70	2276	0.82	2387	0.95	—	—
1050	2058	0.61	2189	0.73	2309	0.86	2421	0.99	—	—
1125	2088	0.63	2219	0.76	2341	0.89	2454	1.03	—	—
1200	2117	0.66	2249	0.79	2372	0.93	2486	1.07	—	—
1275	2146	0.69	2278	0.82	2402	0.97	—	—	—	—
1350	2174	0.72	2307	0.86	2431	1.00	—	—	—	—
1425	2202	0.74	2336	0.89	2460	1.04	—	—	—	—
1500	2230	0.77	2364	0.92	2488	1.07	—	—	—	—

Standard Static 1036-1890 RPM, 0.44 Max BHP

Medium Static 1036-2190 RPM, 0.71 Max BHP

High Static 1036-2490 RPM, 1.07 Max BHP

50FCQA04 SINGLE PHASE - STANDARD STATIC — 3 TON HORIZONTAL SUPPLY (RPM - VDC)

CFM	AVAILABLE EXTERNAL STATIC PRESSURE (in. wg)									
	0.2		0.4		0.6		0.8		1.0	
	RPM	Vdc	RPM	Vdc	RPM	Vdc	RPM	Vdc	RPM	Vdc
900	1036	5.5	1301	6.9	1517	8.0	1698	9.0	1855	9.8
975	1077	5.7	1331	7.0	1546	8.2	1727	9.1	1885	10.0
1050	1119	5.9	1362	7.2	1574	8.3	1755	9.3	—	—
1125	1164	6.2	1394	7.4	1603	8.5	1783	9.4	—	—
1200	1211	6.4	1429	7.6	1632	8.6	1813	9.6	—	—
1275	1261	6.7	1466	7.8	1663	8.8	1841	9.7	—	—
1350	1312	6.9	1506	8.0	1695	9.0	1870	9.9	—	—
1425	1365	7.2	1547	8.2	1729	9.1	—	—	—	—
1500	1419	7.5	1591	8.4	1765	9.3	—	—	—	—

CFM	AVAILABLE EXTERNAL STATIC PRESSURE (in. wg)									
	1.2		1.4		1.6		1.8		2.0	
	RPM	Vdc	RPM	Vdc	RPM	Vdc	RPM	Vdc	RPM	Vdc
900	—	—	—	—	—	—	—	—	—	—
975	—	—	—	—	—	—	—	—	—	—
1050	—	—	—	—	—	—	—	—	—	—
1125	—	—	—	—	—	—	—	—	—	—
1200	—	—	—	—	—	—	—	—	—	—
1275	—	—	—	—	—	—	—	—	—	—
1350	—	—	—	—	—	—	—	—	—	—
1425	—	—	—	—	—	—	—	—	—	—
1500	—	—	—	—	—	—	—	—	—	—

Standard Static 1036-1890 RPM

50FCQA04 SINGLE PHASE - MEDIUM STATIC — 3 TON HORIZONTAL SUPPLY (RPM - VDC)

CFM	AVAILABLE EXTERNAL STATIC PRESSURE (in. wg)									
	0.2		0.4		0.6		0.8		1.0	
	RPM	Vdc	RPM	Vdc	RPM	Vdc	RPM	Vdc	RPM	Vdc
900	1036	4.7	1301	5.9	1517	6.9	1698	7.8	1855	8.5
975	1077	4.9	1331	6.1	1546	7.1	1727	7.9	1885	8.6
1050	1119	5.1	1362	6.2	1574	7.2	1755	8.0	1915	8.7
1125	1164	5.3	1394	6.4	1603	7.3	1783	8.1	1944	8.9
1200	1211	5.5	1429	6.5	1632	7.5	1813	8.3	1972	9.0
1275	1261	5.8	1466	6.7	1663	7.6	1841	8.4	2000	9.1
1350	1312	6.0	1506	6.9	1695	7.7	1870	8.5	2029	9.3
1425	1365	6.2	1547	7.1	1729	7.9	1901	8.7	2057	9.4
1500	1419	6.5	1591	7.3	1765	8.1	1932	8.8	2087	9.5

CFM	AVAILABLE EXTERNAL STATIC PRESSURE (in. wg)									
	1.2		1.4		1.6		1.8		2.0	
	RPM	Vdc	RPM	Vdc	RPM	Vdc	RPM	Vdc	RPM	Vdc
900	1996	9.1	2123	9.7	—	—	—	—	—	—
975	2027	9.3	2157	9.8	—	—	—	—	—	—
1050	2058	9.4	2189	10.0	—	—	—	—	—	—
1125	2088	9.5	—	—	—	—	—	—	—	—
1200	2117	9.7	—	—	—	—	—	—	—	—
1275	2146	9.8	—	—	—	—	—	—	—	—
1350	2174	9.9	—	—	—	—	—	—	—	—
1425	—	—	—	—	—	—	—	—	—	—
1500	—	—	—	—	—	—	—	—	—	—

Medium Static 1036-2190 RPM

50FCQA04 SINGLE PHASE - HIGH STATIC — 3 TON HORIZONTAL SUPPLY (RPM - VDC)

CFM	AVAILABLE EXTERNAL STATIC PRESSURE (in. wg)									
	0.2		0.4		0.6		0.8		1.0	
	RPM	Vdc	RPM	Vdc	RPM	Vdc	RPM	Vdc	RPM	Vdc
900	1036	4.2	1301	5.2	1517	6.1	1698	6.8	1855	7.4
975	1077	4.3	1331	5.3	1546	6.2	1727	6.9	1885	7.6
1050	1119	4.5	1362	5.5	1574	6.3	1755	7.0	1915	7.7
1125	1164	4.7	1394	5.6	1603	6.4	1783	7.2	1944	7.8
1200	1211	4.9	1429	5.7	1632	6.6	1813	7.3	1972	7.9
1275	1261	5.1	1466	5.9	1663	6.7	1841	7.4	2000	8.0
1350	1312	5.3	1506	6.0	1695	6.8	1870	7.5	2029	8.1
1425	1365	5.5	1547	6.2	1729	6.9	1901	7.6	2057	8.3
1500	1419	5.7	1591	6.4	1765	7.1	1932	7.8	2087	8.4

CFM	AVAILABLE EXTERNAL STATIC PRESSURE (in. wg)									
	1.2		1.4		1.6		1.8		2.0	
	RPM	Vdc	RPM	Vdc	RPM	Vdc	RPM	Vdc	RPM	Vdc
900	1996	8.0	2123	8.5	2242	9.0	2352	9.4	2455	9.9
975	2027	8.1	2157	8.7	2276	9.1	2387	9.6	—	—
1050	2058	8.3	2189	8.8	2309	9.3	2421	9.7	—	—
1125	2088	8.4	2219	8.9	2341	9.4	2454	9.9	—	—
1200	2117	8.5	2249	9.0	2372	9.5	2486	10.0	—	—
1275	2146	8.6	2278	9.1	2402	9.6	—	—	—	—
1350	2174	8.7	2307	9.3	2431	9.8	—	—	—	—
1425	2202	8.8	2336	9.4	2460	9.9	—	—	—	—
1500	2230	9.0	2364	9.5	2488	10.0	—	—	—	—

High Static 1036-2490 RPM

50FCQA04 THREE PHASE — 3 TON HORIZONTAL SUPPLY (RPM - BHP)

CFM	AVAILABLE EXTERNAL STATIC PRESSURE (in. wg)									
	0.2		0.4		0.6		0.8		1.0	
	RPM	BHP	RPM	BHP	RPM	BHP	RPM	BHP	RPM	BHP
900	1036	0.08	1301	0.15	1517	0.24	1698	0.34	1855	0.44
975	1076	0.09	1330	0.16	1545	0.26	1727	0.36	1885	0.47
1050	1119	0.10	1361	0.18	1573	0.27	1756	0.38	1915	0.49
1125	1164	0.11	1395	0.19	1602	0.29	1784	0.40	1944	0.51
1200	1211	0.12	1429	0.20	1632	0.30	1812	0.41	1973	0.53
1275	1261	0.14	1466	0.22	1663	0.32	1841	0.43	2001	0.56
1350	1313	0.16	1506	0.24	1695	0.34	1870	0.46	2029	0.58
1425	1366	0.18	1548	0.26	1729	0.36	1900	0.48	2058	0.61
1500	1420	0.20	1591	0.28	1765	0.38	1932	0.50	2087	0.63

CFM	AVAILABLE EXTERNAL STATIC PRESSURE (in. wg)									
	1.2		1.4		1.6		1.8		2.0	
	RPM	BHP	RPM	BHP	RPM	BHP	RPM	BHP	RPM	BHP
900	1995	0.55	2124	0.67	2242	0.78	2352	0.91	2455	1.03
975	2027	0.58	2157	0.70	2276	0.82	2387	0.95	—	—
1050	2058	0.61	2189	0.73	2309	0.86	2421	0.99	—	—
1125	2088	0.63	2219	0.76	2341	0.89	2454	1.03	—	—
1200	2117	0.66	2249	0.79	2372	0.93	2485	1.07	—	—
1275	2146	0.69	2278	0.82	2401	0.96	—	—	—	—
1350	2174	0.72	2307	0.86	2431	1.00	—	—	—	—
1425	2202	0.74	2335	0.89	2460	1.04	—	—	—	—
1500	2231	0.77	2364	0.92	2488	1.07	—	—	—	—

Standard Static 1136-1890 RPM, 0.44 Max BHP

Medium Static 1136-2190 RPM, 0.71 Max BHP

High Static 1136-2490 RPM, 1.07 Max BHP

50FCQA04 THREE PHASE - STANDARD STATIC — 3 TON HORIZONTAL SUPPLY (RPM - VDC)

CFM	AVAILABLE EXTERNAL STATIC PRESSURE (in. wg)									
	0.2		0.4		0.6		0.8		1.0	
	RPM	Vdc	RPM	Vdc	RPM	Vdc	RPM	Vdc	RPM	Vdc
900	1036	5.5	1301	6.9	1517	8.0	1698	9.0	1855	9.8
975	1076	5.7	1330	7.0	1545	8.2	1727	9.1	1885	10.0
1050	1119	5.9	1361	7.2	1573	8.3	1756	9.3	—	—
1125	1164	6.2	1395	7.4	1602	8.5	1784	9.4	—	—
1200	1211	6.4	1429	7.6	1632	8.6	1812	9.6	—	—
1275	1261	6.7	1466	7.8	1663	8.8	1841	9.7	—	—
1350	1313	6.9	1506	8.0	1695	9.0	1870	9.9	—	—
1425	1366	7.2	1548	8.2	1729	9.1	—	—	—	—
1500	1420	7.5	1591	8.4	1765	9.3	—	—	—	—

CFM	AVAILABLE EXTERNAL STATIC PRESSURE (in. wg)									
	1.2		1.4		1.6		1.8		2.0	
	RPM	Vdc	RPM	Vdc	RPM	Vdc	RPM	Vdc	RPM	Vdc
900	—	—	—	—	—	—	—	—	—	—
975	—	—	—	—	—	—	—	—	—	—
1050	—	—	—	—	—	—	—	—	—	—
1125	—	—	—	—	—	—	—	—	—	—
1200	—	—	—	—	—	—	—	—	—	—
1275	—	—	—	—	—	—	—	—	—	—
1350	—	—	—	—	—	—	—	—	—	—
1425	—	—	—	—	—	—	—	—	—	—
1500	—	—	—	—	—	—	—	—	—	—

Standard Static 1136-1890 RPM



50FCQA04 THREE PHASE - MEDIUM STATIC — 3 TON HORIZONTAL SUPPLY (RPM - VDC)

CFM	AVAILABLE EXTERNAL STATIC PRESSURE (in. wg)									
	0.2		0.4		0.6		0.8		1.0	
	RPM	Vdc	RPM	Vdc	RPM	Vdc	RPM	Vdc	RPM	Vdc
900	1036	4.7	1301	5.9	1517	6.9	1698	7.8	1855	8.5
975	1076	4.9	1330	6.1	1545	7.1	1727	7.9	1885	8.6
1050	1119	5.1	1361	6.2	1573	7.2	1756	8.0	1915	8.7
1125	1164	5.3	1395	6.4	1602	7.3	1784	8.1	1944	8.9
1200	1211	5.5	1429	6.5	1632	7.5	1812	8.3	1973	9.0
1275	1261	5.8	1466	6.7	1663	7.6	1841	8.4	2001	9.1
1350	1313	6.0	1506	6.9	1695	7.7	1870	8.5	2029	9.3
1425	1366	6.2	1548	7.1	1729	7.9	1900	8.7	2058	9.4
1500	1420	6.5	1591	7.3	1765	8.1	1932	8.8	2087	9.5

CFM	AVAILABLE EXTERNAL STATIC PRESSURE (in. wg)									
	1.2		1.4		1.6		1.8		2.0	
	RPM	Vdc	RPM	Vdc	RPM	Vdc	RPM	Vdc	RPM	Vdc
900	1995	9.1	2124	9.7	—	—	—	—	—	—
975	2027	9.3	2157	9.8	—	—	—	—	—	—
1050	2058	9.4	2189	10.0	—	—	—	—	—	—
1125	2088	9.5	—	—	—	—	—	—	—	—
1200	2117	9.7	—	—	—	—	—	—	—	—
1275	2146	9.8	—	—	—	—	—	—	—	—
1350	2174	9.9	—	—	—	—	—	—	—	—
1425	—	—	—	—	—	—	—	—	—	—
1500	—	—	—	—	—	—	—	—	—	—

Medium Static 1136-2190 RPM

50FCQA04 THREE PHASE - HIGH STATIC — 3 TON HORIZONTAL SUPPLY (RPM - VDC)

CFM	AVAILABLE EXTERNAL STATIC PRESSURE (in. wg)									
	0.2		0.4		0.6		0.8		1.0	
	RPM	Vdc	RPM	Vdc	RPM	Vdc	RPM	Vdc	RPM	Vdc
900	1036	4.2	1301	5.2	1517	6.1	1698	6.8	1855	7.4
975	1076	4.3	1330	5.3	1545	6.2	1727	6.9	1885	7.6
1050	1119	4.5	1361	5.5	1573	6.3	1756	7.1	1915	7.7
1125	1164	4.7	1395	5.6	1602	6.4	1784	7.2	1944	7.8
1200	1211	4.9	1429	5.7	1632	6.6	1812	7.3	1973	7.9
1275	1261	5.1	1466	5.9	1663	6.7	1841	7.4	2001	8.0
1350	1313	5.3	1506	6.0	1695	6.8	1870	7.5	2029	8.1
1425	1366	5.5	1548	6.2	1729	6.9	1900	7.6	2058	8.3
1500	1420	5.7	1591	6.4	1765	7.1	1932	7.8	2087	8.4

CFM	AVAILABLE EXTERNAL STATIC PRESSURE (in. wg)									
	1.2		1.4		1.6		1.8		2.0	
	RPM	Vdc	RPM	Vdc	RPM	Vdc	RPM	Vdc	RPM	Vdc
900	1995	8.0	2124	8.5	2242	9.0	2352	9.4	2455	9.9
975	2027	8.1	2157	8.7	2276	9.1	2387	9.6	—	—
1050	2058	8.3	2189	8.8	2309	9.3	2421	9.7	—	—
1125	2088	8.4	2219	8.9	2341	9.4	2454	9.9	—	—
1200	2117	8.5	2249	9.0	2372	9.5	2485	10.0	—	—
1275	2146	8.6	2278	9.1	2401	9.6	—	—	—	—
1350	2174	8.7	2307	9.3	2431	9.8	—	—	—	—
1425	2202	8.8	2335	9.4	2460	9.9	—	—	—	—
1500	2231	9.0	2364	9.5	2488	10.0	—	—	—	—

High Static 1136-2490 RPM

50FCQA05 SINGLE PHASE — 4 TON HORIZONTAL SUPPLY (RPM - BHP)

CFM	AVAILABLE EXTERNAL STATIC PRESSURE (in. wg)									
	0.2		0.4		0.6		0.8		1.0	
	RPM	BHP	RPM	BHP	RPM	BHP	RPM	BHP	RPM	BHP
1200	1066	0.13	1280	0.22	1473	0.34	1644	0.47	1798	0.61
1300	1120	0.15	1320	0.24	1506	0.36	1674	0.49	1826	0.64
1400	1177	0.17	1363	0.26	1541	0.38	1705	0.52	1856	0.67
1500	1236	0.20	1409	0.29	1579	0.41	1739	0.55	1886	0.70
1600	1297	0.23	1458	0.32	1620	0.44	1774	0.58	1918	0.73
1700	1359	0.26	1509	0.35	1663	0.47	1811	0.61	1952	0.77
1800	1423	0.30	1563	0.39	1708	0.51	1851	0.65	1987	0.81
1900	1487	0.34	1619	0.44	1756	0.56	1893	0.70	2025	0.85
2000	1552	0.38	1677	0.48	1806	0.60	1937	0.74	2064	0.90

CFM	AVAILABLE EXTERNAL STATIC PRESSURE (in. wg)									
	1.2		1.4		1.6		1.8		2.0	
	RPM	BHP	RPM	BHP	RPM	BHP	RPM	BHP	RPM	BHP
1200	1938	0.77	2069	0.93	2192	1.11	2309	1.29	2420	1.49
1300	1965	0.79	2095	0.96	2216	1.14	2331	1.33	2441	1.52
1400	1993	0.82	2121	0.99	2242	1.17	2356	1.36	—	—
1500	2023	0.86	2149	1.03	2269	1.21	2382	1.40	—	—
1600	2053	0.89	2178	1.07	2297	1.25	2409	1.45	—	—
1700	2084	0.93	2209	1.11	2326	1.30	2437	1.49	—	—
1800	2117	0.98	2239	1.15	2356	1.34	—	—	—	—
1900	2151	1.02	2272	1.20	2386	1.39	—	—	—	—
2000	2187	1.07	2305	1.25	2418	1.45	—	—	—	—

Standard Static 1066-1900 RPM, 0.72 Max BHP

Medium Static 1066-2170 RPM, 1.06 Max BHP

High Static 1066-2460 RPM, 1.53 Max BHP

50FCQA05 SINGLE PHASE - STANDARD STATIC — 4 TON HORIZONTAL SUPPLY (RPM - VDC)

CFM	AVAILABLE EXTERNAL STATIC PRESSURE (in. wg)									
	0.2		0.4		0.6		0.8		1.0	
	RPM	Vdc	RPM	Vdc	RPM	Vdc	RPM	Vdc	RPM	Vdc
1200	1066	5.6	1280	6.7	1473	7.8	1644	8.7	1798	9.5
1300	1120	5.9	1320	6.9	1506	7.9	1674	8.8	1826	9.6
1400	1177	6.2	1363	7.2	1541	8.1	1705	9.0	1856	9.8
1500	1236	6.5	1409	7.4	1579	8.3	1739	9.2	1886	9.9
1600	1297	6.8	1458	7.7	1620	8.5	1774	9.3	—	—
1700	1359	7.2	1509	7.9	1663	8.8	1811	9.5	—	—
1800	1423	7.5	1563	8.2	1708	9.0	1851	9.7	—	—
1900	1487	7.8	1619	8.5	1756	9.2	1893	10.0	—	—
2000	1552	8.2	1677	8.8	1806	9.5	—	—	—	—

CFM	AVAILABLE EXTERNAL STATIC PRESSURE (in. wg)									
	1.2		1.4		1.6		1.8		2.0	
	RPM	Vdc	RPM	Vdc	RPM	Vdc	RPM	Vdc	RPM	Vdc
1200	—	—	—	—	—	—	—	—	—	—
1300	—	—	—	—	—	—	—	—	—	—
1400	—	—	—	—	—	—	—	—	—	—
1500	—	—	—	—	—	—	—	—	—	—
1600	—	—	—	—	—	—	—	—	—	—
1700	—	—	—	—	—	—	—	—	—	—
1800	—	—	—	—	—	—	—	—	—	—
1900	—	—	—	—	—	—	—	—	—	—
2000	—	—	—	—	—	—	—	—	—	—

Standard Static 1066-1900 RPM



50FCQA05 SINGLE PHASE - MEDIUM STATIC — 4 TON HORIZONTAL SUPPLY (RPM - VDC)

CFM	AVAILABLE EXTERNAL STATIC PRESSURE (in. wg)									
	0.2		0.4		0.6		0.8		1.0	
	RPM	Vdc	RPM	Vdc	RPM	Vdc	RPM	Vdc	RPM	Vdc
1200	1066	4.9	1280	5.9	1473	6.8	1644	7.6	1798	8.3
1300	1120	5.2	1320	6.1	1506	6.9	1674	7.7	1826	8.4
1400	1177	5.4	1363	6.3	1541	7.1	1705	7.9	1856	8.6
1500	1236	5.7	1409	6.5	1579	7.3	1739	8.0	1886	8.7
1600	1297	6.0	1458	6.7	1620	7.5	1774	8.2	1918	8.8
1700	1359	6.3	1509	7.0	1663	7.7	1811	8.3	1952	9.0
1800	1423	6.6	1563	7.2	1708	7.9	1851	8.5	1987	9.2
1900	1487	6.9	1619	7.5	1756	8.1	1893	8.7	2025	9.3
2000	1552	7.2	1677	7.7	1806	8.3	1937	8.9	2064	9.5

CFM	AVAILABLE EXTERNAL STATIC PRESSURE (in. wg)									
	1.2		1.4		1.6		1.8		2.0	
	RPM	Vdc	RPM	Vdc	RPM	Vdc	RPM	Vdc	RPM	Vdc
1200	1938	8.9	2069	9.5	—	—	—	—	—	—
1300	1965	9.1	2095	9.7	—	—	—	—	—	—
1400	1993	9.2	2121	9.8	—	—	—	—	—	—
1500	2023	9.3	2149	9.9	—	—	—	—	—	—
1600	2053	9.5	—	—	—	—	—	—	—	—
1700	2084	9.6	—	—	—	—	—	—	—	—
1800	2117	9.8	—	—	—	—	—	—	—	—
1900	2151	9.9	—	—	—	—	—	—	—	—
2000	—	—	—	—	—	—	—	—	—	—

Medium Static 1066-2170 RPM

50FCQA05 SINGLE PHASE - HIGH STATIC — 4 TON HORIZONTAL SUPPLY (RPM - VDC)

CFM	AVAILABLE EXTERNAL STATIC PRESSURE (in. wg)									
	0.2		0.4		0.6		0.8		1.0	
	RPM	Vdc	RPM	Vdc	RPM	Vdc	RPM	Vdc	RPM	Vdc
1200	1066	4.3	1280	5.2	1473	6.0	1644	6.7	1798	7.3
1300	1120	4.6	1320	5.4	1506	6.1	1674	6.8	1826	7.4
1400	1177	4.8	1363	5.5	1541	6.3	1705	6.9	1856	7.5
1500	1236	5.0	1409	5.7	1579	6.4	1739	7.1	1886	7.7
1600	1297	5.3	1458	5.9	1620	6.6	1774	7.2	1918	7.8
1700	1359	5.5	1509	6.1	1663	6.8	1811	7.4	1952	7.9
1800	1423	5.8	1563	6.4	1708	6.9	1851	7.5	1987	8.1
1900	1487	6.0	1619	6.6	1756	7.1	1893	7.7	2025	8.2
2000	1552	6.3	1677	6.8	1806	7.3	1937	7.9	2064	8.4

CFM	AVAILABLE EXTERNAL STATIC PRESSURE (in. wg)									
	1.2		1.4		1.6		1.8		2.0	
	RPM	Vdc	RPM	Vdc	RPM	Vdc	RPM	Vdc	RPM	Vdc
1200	1938	7.9	2069	8.4	2192	8.9	2309	9.4	2420	9.8
1300	1965	8.0	2095	8.5	2216	9.0	2331	9.5	2441	9.9
1400	1993	8.1	2121	8.6	2242	9.1	2356	9.6	—	—
1500	2023	8.2	2149	8.7	2269	9.2	2382	9.7	—	—
1600	2053	8.3	2178	8.9	2297	9.3	2409	9.8	—	—
1700	2084	8.5	2209	9.0	2326	9.5	2437	9.9	—	—
1800	2117	8.6	2239	9.1	2356	9.6	—	—	—	—
1900	2151	8.7	2272	9.2	2386	9.7	—	—	—	—
2000	2187	8.9	2305	9.4	2418	9.8	—	—	—	—

High Static 1066-2460 RPM

50FCQA05 THREE PHASE — 4 TON HORIZONTAL SUPPLY (RPM - BHP)

CFM	AVAILABLE EXTERNAL STATIC PRESSURE (in. wg)									
	0.2		0.4		0.6		0.8		1.0	
	RPM	BHP	RPM	BHP	RPM	BHP	RPM	BHP	RPM	BHP
1200	1067	0.13	1280	0.22	1473	0.34	1645	0.47	1798	0.61
1300	1121	0.15	1320	0.24	1506	0.36	1675	0.49	1827	0.64
1400	1177	0.17	1363	0.26	1542	0.38	1706	0.52	1856	0.67
1500	1237	0.20	1409	0.29	1579	0.41	1739	0.55	1887	0.70
1600	1297	0.23	1458	0.32	1620	0.44	1774	0.58	1919	0.73
1700	1359	0.26	1510	0.35	1663	0.47	1811	0.61	1952	0.77
1800	1423	0.30	1563	0.39	1708	0.51	1851	0.65	1988	0.81
1900	1487	0.34	1619	0.44	1756	0.56	1893	0.70	2025	0.85
2000	1552	0.38	1677	0.48	1807	0.60	1937	0.74	2064	0.90

CFM	AVAILABLE EXTERNAL STATIC PRESSURE (in. wg)									
	1.2		1.4		1.6		1.8		2.0	
	RPM	BHP	RPM	BHP	RPM	BHP	RPM	BHP	RPM	BHP
1200	1939	0.77	2070	0.93	2192	1.11	2309	1.29	2420	1.49
1300	1965	0.79	2095	0.96	2217	1.14	2332	1.33	2442	1.52
1400	1993	0.82	2121	0.99	2242	1.17	2356	1.36	2465	1.56
1500	2022	0.86	2149	1.03	2269	1.21	2382	1.40	2490	1.60
1600	2053	0.89	2178	1.07	2297	1.25	2409	1.45	2516	1.65
1700	2085	0.93	2208	1.11	2326	1.30	2437	1.49	2543	1.69
1800	2117	0.98	2240	1.16	2356	1.34	2466	1.54	2571	1.75
1900	2152	1.02	2272	1.20	2386	1.39	2496	1.59	2600	1.80
2000	2188	1.07	2306	1.25	2418	1.45	2526	1.65	2630	1.86

Standard Static 1067-1900 RPM, 0.72 Max BHP

Medium Static 1067-2170 RPM, 1.06 Max BHP

High Static 101672660 RPM, 1.96 Max BHP

50FCQA05 THREE PHASE - STANDARD STATIC — 4 TON HORIZONTAL SUPPLY (RPM - VDC)

CFM	AVAILABLE EXTERNAL STATIC PRESSURE (in. wg)									
	0.2		0.4		0.6		0.8		1.0	
	RPM	Vdc	RPM	Vdc	RPM	Vdc	RPM	Vdc	RPM	Vdc
1200	1067	5.6	1280	6.7	1473	7.8	1645	8.7	1798	9.5
1300	1121	5.9	1320	6.9	1506	7.9	1675	8.8	1827	9.6
1400	1177	6.2	1363	7.2	1542	8.1	1706	9.0	1856	9.8
1500	1237	6.5	1409	7.4	1579	8.3	1739	9.2	1887	9.9
1600	1297	6.8	1458	7.7	1620	8.5	1774	9.3	—	—
1700	1359	7.2	1510	7.9	1663	8.8	1811	9.5	—	—
1800	1423	7.5	1563	8.2	1708	9.0	1851	9.7	—	—
1900	1487	7.8	1619	8.5	1756	9.2	1893	10.0	—	—
2000	1552	8.2	1677	8.8	1807	9.5	—	—	—	—

CFM	AVAILABLE EXTERNAL STATIC PRESSURE (in. wg)									
	1.2		1.4		1.6		1.8		2.0	
	RPM	Vdc	RPM	Vdc	RPM	Vdc	RPM	Vdc	RPM	Vdc
1200	—	—	—	—	—	—	—	—	—	—
1300	—	—	—	—	—	—	—	—	—	—
1400	—	—	—	—	—	—	—	—	—	—
1500	—	—	—	—	—	—	—	—	—	—
1600	—	—	—	—	—	—	—	—	—	—
1700	—	—	—	—	—	—	—	—	—	—
1800	—	—	—	—	—	—	—	—	—	—
1900	—	—	—	—	—	—	—	—	—	—
2000	—	—	—	—	—	—	—	—	—	—

Standard Static 1067-1900 RPM



50FCQA05 THREE PHASE - MEDIUM STATIC — 4 TON HORIZONTAL SUPPLY (RPM - VDC)

CFM	AVAILABLE EXTERNAL STATIC PRESSURE (in. wg)									
	0.2		0.4		0.6		0.8		1.0	
	RPM	Vdc	RPM	Vdc	RPM	Vdc	RPM	Vdc	RPM	Vdc
1200	1067	4.9	1280	5.9	1473	6.8	1645	7.6	1798	8.3
1300	1121	5.2	1320	6.1	1506	6.9	1675	7.7	1827	8.4
1400	1177	5.4	1363	6.3	1542	7.1	1706	7.9	1856	8.6
1500	1237	5.7	1409	6.5	1579	7.3	1739	8.0	1887	8.7
1600	1297	6.0	1458	6.7	1620	7.5	1774	8.2	1919	8.8
1700	1359	6.3	1510	7.0	1663	7.7	1811	8.3	1952	9.0
1800	1423	6.6	1563	7.2	1708	7.9	1851	8.5	1988	9.2
1900	1487	6.9	1619	7.5	1756	8.1	1893	8.7	2025	9.3
2000	1552	7.2	1677	7.7	1807	8.3	1937	8.9	2064	9.5

CFM	AVAILABLE EXTERNAL STATIC PRESSURE (in. wg)									
	1.2		1.4		1.6		1.8		2.0	
	RPM	Vdc	RPM	Vdc	RPM	Vdc	RPM	Vdc	RPM	Vdc
1200	1939	8.9	2070	9.5	—	—	—	—	—	—
1300	1965	9.1	2095	9.7	—	—	—	—	—	—
1400	1993	9.2	2121	9.8	—	—	—	—	—	—
1500	2022	9.3	2149	9.9	—	—	—	—	—	—
1600	2053	9.5	—	—	—	—	—	—	—	—
1700	2085	9.6	—	—	—	—	—	—	—	—
1800	2117	9.8	—	—	—	—	—	—	—	—
1900	2152	9.9	—	—	—	—	—	—	—	—
2000	—	—	—	—	—	—	—	—	—	—

Medium Static 1067-2170 RPM

50FCQA05 THREE PHASE - HIGH STATIC — 4 TON HORIZONTAL SUPPLY (RPM - VDC)

CFM	AVAILABLE EXTERNAL STATIC PRESSURE (in. wg)									
	0.2		0.4		0.6		0.8		1.0	
	RPM	Vdc	RPM	Vdc	RPM	Vdc	RPM	Vdc	RPM	Vdc
1200	1067	4.0	1280	4.8	1473	5.5	1645	6.2	1798	6.8
1300	1121	4.2	1320	5.0	1506	5.7	1675	6.3	1827	6.9
1400	1177	4.4	1363	5.1	1542	5.8	1706	6.4	1856	7.0
1500	1237	4.7	1409	5.3	1579	5.9	1739	6.5	1887	7.1
1600	1297	4.9	1458	5.5	1620	6.1	1774	6.7	1919	7.2
1700	1359	5.1	1510	5.7	1663	6.3	1811	6.8	1952	7.3
1800	1423	5.3	1563	5.9	1708	6.4	1851	7.0	1988	7.5
1900	1487	5.6	1619	6.1	1756	6.6	1893	7.1	2025	7.6
2000	1552	5.8	1677	6.3	1807	6.8	1937	7.3	2064	7.8

CFM	AVAILABLE EXTERNAL STATIC PRESSURE (in. wg)									
	1.2		1.4		1.6		1.8		2.0	
	RPM	Vdc	RPM	Vdc	RPM	Vdc	RPM	Vdc	RPM	Vdc
1200	1939	7.3	2070	7.8	2192	8.2	2309	8.7	2420	9.1
1300	1965	7.4	2095	7.9	2217	8.3	2332	8.8	2442	9.2
1400	1993	7.5	2121	8.0	2242	8.4	2356	8.9	2465	9.3
1500	2022	7.6	2149	8.1	2269	8.5	2382	9.0	2490	9.4
1600	2053	7.7	2178	8.2	2297	8.6	2409	9.1	2516	9.5
1700	2085	7.8	2208	8.3	2326	8.7	2437	9.2	2543	9.6
1800	2117	8.0	2240	8.4	2356	8.9	2466	9.3	2571	9.7
1900	2152	8.1	2272	8.5	2386	9.0	2496	9.4	2600	9.8
2000	2188	8.2	2306	8.7	2418	9.1	2526	9.5	2630	9.9

High Static 1067-2660 RPM

50FCQA06 SINGLE PHASE — 5 TON HORIZONTAL SUPPLY (RPM - BHP)

CFM	AVAILABLE EXTERNAL STATIC PRESSURE (in. wg)									
	0.2		0.4		0.6		0.8		1.0	
	RPM	BHP	RPM	BHP	RPM	BHP	RPM	BHP	RPM	BHP
1500	1197	0.18	1360	0.26	1525	0.37	1679	0.49	1822	0.62
1625	1271	0.21	1421	0.29	1574	0.40	1721	0.52	1860	0.66
1750	1348	0.25	1485	0.33	1627	0.44	1767	0.56	1901	0.70
1875	1425	0.29	1553	0.38	1684	0.49	1817	0.61	1945	0.75
2000	1504	0.35	1623	0.43	1745	0.54	1870	0.66	1992	0.80
2125	1585	0.40	1695	0.49	1809	0.60	1926	0.72	2043	0.86
2250	1666	0.47	1769	0.56	1876	0.67	1986	0.79	2096	0.93
2375	1747	0.54	1844	0.63	1945	0.74	2049	0.87	2153	1.01
2500	1830	0.62	1921	0.71	2016	0.82	2114	0.95	2213	1.09

CFM	AVAILABLE EXTERNAL STATIC PRESSURE (in. wg)									
	1.2		1.4		1.6		1.8		2.0	
	RPM	BHP	RPM	BHP	RPM	BHP	RPM	BHP	RPM	BHP
1500	1954	0.77	2078	0.92	2194	1.09	2304	1.26	2408	1.44
1625	1990	0.81	2112	0.97	2227	1.13	2336	1.31	2439	1.49
1750	2028	0.85	2148	1.01	2262	1.18	2370	1.36	2472	1.54
1875	2069	0.90	2186	1.06	2298	1.23	2404	1.41	2506	1.60
2000	2111	0.95	2226	1.12	2336	1.29	2441	1.48	2541	1.66
2125	2157	1.02	2268	1.18	2375	1.36	2478	1.54	2578	1.73
2250	2206	1.08	2313	1.25	2417	1.43	2518	1.61	2616	1.81
2375	2258	1.16	2361	1.33	2461	1.50	2560	1.69	2655	1.89
2500	2312	1.24	2411	1.41	2508	1.59	2604	1.78	—	—

Standard Static 1197-2150 RPM, 1.06 Max BHP

Medium Static 1197-2390 RPM, 1.44 Max BHP

High Static 1197-2660 RPM, 1.96 Max BHP

50FCQA06 SINGLE PHASE - STANDARD STATIC — 5 TON HORIZONTAL SUPPLY (RPM - VDC)

CFM	AVAILABLE EXTERNAL STATIC PRESSURE (in. wg)									
	0.2		0.4		0.6		0.8		1.0	
	RPM	Vdc	RPM	Vdc	RPM	Vdc	RPM	Vdc	RPM	Vdc
1500	1197	5.6	1360	6.3	1525	7.1	1679	7.8	1822	8.5
1625	1271	5.9	1421	6.6	1574	7.3	1721	8.0	1860	8.7
1750	1348	6.3	1485	6.9	1627	7.6	1767	8.2	1901	8.8
1875	1425	6.6	1553	7.2	1684	7.8	1817	8.5	1945	9.0
2000	1504	7.0	1623	7.5	1745	8.1	1870	8.7	1992	9.3
2125	1585	7.4	1695	7.9	1809	8.4	1926	9.0	2043	9.5
2250	1666	7.7	1769	8.2	1876	8.7	1986	9.2	2096	9.7
2375	1747	8.1	1844	8.6	1945	9.0	2049	9.5	—	—
2500	1830	8.5	1921	8.9	2016	9.4	2114	9.8	—	—

CFM	AVAILABLE EXTERNAL STATIC PRESSURE (in. wg)									
	1.2		1.4		1.6		1.8		2.0	
	RPM	Vdc	RPM	Vdc	RPM	Vdc	RPM	Vdc	RPM	Vdc
1500	1954	9.1	2078	9.7	—	—	—	—	—	—
1625	1990	9.3	2112	9.8	—	—	—	—	—	—
1750	2028	9.4	2148	10.0	—	—	—	—	—	—
1875	2069	9.6	—	—	—	—	—	—	—	—
2000	2111	9.8	—	—	—	—	—	—	—	—
2125	—	—	—	—	—	—	—	—	—	—
2250	—	—	—	—	—	—	—	—	—	—
2375	—	—	—	—	—	—	—	—	—	—
2500	—	—	—	—	—	—	—	—	—	—

Standard Static 1197-2150 RPM



50FCQA06 SINGLE PHASE - MEDIUM STATIC — 5 TON HORIZONTAL SUPPLY (RPM - VDC)

CFM	AVAILABLE EXTERNAL STATIC PRESSURE (in. wg)									
	0.2		0.4		0.6		0.8		1.0	
	RPM	Vdc	RPM	Vdc	RPM	Vdc	RPM	Vdc	RPM	Vdc
1500	1197	5.0	1360	5.7	1525	6.4	1679	7.0	1822	7.6
1625	1271	5.3	1421	5.9	1574	6.6	1721	7.2	1860	7.8
1750	1348	5.6	1485	6.2	1627	6.8	1767	7.4	1901	8.0
1875	1425	6.0	1553	6.5	1684	7.0	1817	7.6	1945	8.1
2000	1504	6.3	1623	6.8	1745	7.3	1870	7.8	1992	8.3
2125	1585	6.6	1695	7.1	1809	7.6	1926	8.1	2043	8.5
2250	1666	7.0	1769	7.4	1876	7.8	1986	8.3	2096	8.8
2375	1747	7.3	1844	7.7	1945	8.1	2049	8.6	2153	9.0
2500	1830	7.7	1921	8.0	2016	8.4	2114	8.8	2213	9.3

CFM	AVAILABLE EXTERNAL STATIC PRESSURE (in. wg)									
	1.2		1.4		1.6		1.8		2.0	
	RPM	Vdc	RPM	Vdc	RPM	Vdc	RPM	Vdc	RPM	Vdc
1500	1954	8.2	2078	8.7	2194	9.2	2304	9.6	—	—
1625	1990	8.3	2112	8.8	2227	9.3	2336	9.8	—	—
1750	2028	8.5	2148	9.0	2262	9.5	2370	9.9	—	—
1875	2069	8.7	2186	9.1	2298	9.6	—	—	—	—
2000	2111	8.8	2226	9.3	2336	9.8	—	—	—	—
2125	2157	9.0	2268	9.5	2375	9.9	—	—	—	—
2250	2206	9.2	2313	9.7	—	—	—	—	—	—
2375	2258	9.4	2361	9.9	—	—	—	—	—	—
2500	2312	9.7	—	—	—	—	—	—	—	—

Medium Static 1197-2390 RPM

50FCQA06 SINGLE PHASE - HIGH STATIC — 5 TON HORIZONTAL SUPPLY (RPM - VDC)

CFM	AVAILABLE EXTERNAL STATIC PRESSURE (in. wg)									
	0.2		0.4		0.6		0.8		1.0	
	RPM	Vdc	RPM	Vdc	RPM	Vdc	RPM	Vdc	RPM	Vdc
1500	1197	4.5	1360	5.1	1525	5.7	1679	6.3	1822	6.8
1625	1271	4.8	1421	5.3	1574	5.9	1721	6.5	1860	7.0
1750	1348	5.1	1485	5.6	1627	6.1	1767	6.6	1901	7.1
1875	1425	5.4	1553	5.8	1684	6.3	1817	6.8	1945	7.3
2000	1504	5.7	1623	6.1	1745	6.6	1870	7.0	1992	7.5
2125	1585	6.0	1695	6.4	1809	6.8	1926	7.2	2043	7.7
2250	1666	6.3	1769	6.7	1876	7.1	1986	7.5	2096	7.9
2375	1747	6.6	1844	6.9	1945	7.3	2049	7.7	2153	8.1
2500	1830	6.9	1921	7.2	2016	7.6	2114	7.9	2213	8.3

CFM	AVAILABLE EXTERNAL STATIC PRESSURE (in. wg)									
	1.2		1.4		1.6		1.8		2.0	
	RPM	Vdc	RPM	Vdc	RPM	Vdc	RPM	Vdc	RPM	Vdc
1500	1954	7.3	2078	7.8	2194	8.2	2304	8.7	2408	9.1
1625	1990	7.5	2112	7.9	2227	8.4	2336	8.8	2439	9.2
1750	2028	7.6	2148	8.1	2262	8.5	2370	8.9	2472	9.3
1875	2069	7.8	2186	8.2	2298	8.6	2404	9.0	2506	9.4
2000	2111	7.9	2226	8.4	2336	8.8	2441	9.2	2541	9.6
2125	2157	8.1	2268	8.5	2375	8.9	2478	9.3	2578	9.7
2250	2206	8.3	2313	8.7	2417	9.1	2518	9.5	2616	9.8
2375	2258	8.5	2361	8.9	2461	9.3	2560	9.6	2655	10.0
2500	2312	8.7	2411	9.1	2508	9.4	2604	9.8	—	—

High Static 1197-2660 RPM

50FCQA06 THREE PHASE — 5 TON HORIZONTAL SUPPLY (RPM - BHP)

CFM	AVAILABLE EXTERNAL STATIC PRESSURE (in. wg)									
	0.2		0.4		0.6		0.8		1.0	
	RPM	BHP	RPM	BHP	RPM	BHP	RPM	BHP	RPM	BHP
1500	1196	0.18	1360	0.26	1525	0.37	1679	0.49	1822	0.62
1625	1271	0.21	1421	0.29	1574	0.40	1721	0.52	1860	0.66
1750	1348	0.25	1485	0.33	1627	0.44	1767	0.56	1901	0.70
1875	1425	0.29	1553	0.38	1684	0.49	1817	0.61	1945	0.75
2000	1504	0.35	1622	0.43	1745	0.54	1870	0.66	1993	0.80
2125	1585	0.40	1695	0.49	1809	0.60	1926	0.72	2043	0.86
2250	1666	0.47	1769	0.56	1876	0.67	1986	0.79	2096	0.93
2375	1747	0.54	1844	0.63	1945	0.74	2049	0.87	2153	1.01
2500	1829	0.62	1921	0.71	2016	0.82	2114	0.95	2213	1.09

CFM	AVAILABLE EXTERNAL STATIC PRESSURE (in. wg)									
	1.2		1.4		1.6		1.8		2.0	
	RPM	BHP	RPM	BHP	RPM	BHP	RPM	BHP	RPM	BHP
1500	1954	0.77	2078	0.92	2194	1.09	2304	1.26	2408	1.44
1625	1990	0.81	2112	0.97	2227	1.13	2336	1.31	2439	1.49
1750	2028	0.85	2148	1.01	2262	1.18	2370	1.36	2472	1.54
1875	2069	0.90	2186	1.06	2298	1.23	2404	1.41	2506	1.60
2000	2112	0.96	2226	1.12	2336	1.29	2441	1.48	2541	1.66
2125	2157	1.02	2268	1.18	2376	1.36	2479	1.54	2578	1.73
2250	2206	1.08	2313	1.25	2418	1.43	2518	1.61	2616	1.81
2375	2258	1.16	2361	1.33	2462	1.50	2560	1.69	2656	1.89
2500	2312	1.24	2411	1.41	2508	1.59	2604	1.78	2698	1.97

Standard Static 1196-2150 RPM, 1.06 Max BHP

Medium Static 1196-2390 RPM, 1.44 Max BHP

High Static 1196-2836 RPM, 2.43 Max BHP

50FCQA06 THREE PHASE - STANDARD STATIC — 5 TON HORIZONTAL SUPPLY (RPM - VDC)

CFM	AVAILABLE EXTERNAL STATIC PRESSURE (in. wg)									
	0.2		0.4		0.6		0.8		1.0	
	RPM	Vdc	RPM	Vdc	RPM	Vdc	RPM	Vdc	RPM	Vdc
1500	1196	5.6	1360	6.3	1525	7.1	1679	7.8	1822	8.5
1625	1271	5.9	1421	6.6	1574	7.3	1721	8.0	1860	8.7
1750	1348	6.3	1485	6.9	1627	7.6	1767	8.2	1901	8.8
1875	1425	6.6	1553	7.2	1684	7.8	1817	8.5	1945	9.0
2000	1504	7.0	1622	7.5	1745	8.1	1870	8.7	1993	9.3
2125	1585	7.4	1695	7.9	1809	8.4	1926	9.0	2043	9.5
2250	1666	7.7	1769	8.2	1876	8.7	1986	9.2	2096	9.7
2375	1747	8.1	1844	8.6	1945	9.0	2049	9.5	—	—
2500	1829	8.5	1921	8.9	2016	9.4	2114	9.8	—	—

CFM	AVAILABLE EXTERNAL STATIC PRESSURE (in. wg)									
	1.2		1.4		1.6		1.8		2.0	
	RPM	Vdc	RPM	Vdc	RPM	Vdc	RPM	Vdc	RPM	Vdc
1500	1954	9.1	2078	9.7	—	—	—	—	—	—
1625	1990	9.3	2112	9.8	—	—	—	—	—	—
1750	2028	9.4	2148	10.0	—	—	—	—	—	—
1875	2069	9.6	—	—	—	—	—	—	—	—
2000	2112	9.8	—	—	—	—	—	—	—	—
2125	—	—	—	—	—	—	—	—	—	—
2250	—	—	—	—	—	—	—	—	—	—
2375	—	—	—	—	—	—	—	—	—	—
2500	—	—	—	—	—	—	—	—	—	—

Standard Static 1196-2150 RPM

50FCQA06 THREE PHASE - MEDIUM STATIC — 5 TON HORIZONTAL SUPPLY (RPM - VDC)

CFM	AVAILABLE EXTERNAL STATIC PRESSURE (in. wg)									
	0.2		0.4		0.6		0.8		1.0	
	RPM	Vdc	RPM	Vdc	RPM	Vdc	RPM	Vdc	RPM	Vdc
1500	1196	5.0	1360	5.7	1525	6.4	1679	7.0	1822	7.6
1625	1271	5.3	1421	5.9	1574	6.6	1721	7.2	1860	7.8
1750	1348	5.6	1485	6.2	1627	6.8	1767	7.4	1901	8.0
1875	1425	6.0	1553	6.5	1684	7.0	1817	7.6	1945	8.1
2000	1504	6.3	1622	6.8	1745	7.3	1870	7.8	1993	8.3
2125	1585	6.6	1695	7.1	1809	7.6	1926	8.1	2043	8.5
2250	1666	7.0	1769	7.4	1876	7.8	1986	8.3	2096	8.8
2375	1747	7.3	1844	7.7	1945	8.1	2049	8.6	2153	9.0
2500	1829	7.7	1921	8.0	2016	8.4	2114	8.8	2213	9.3

CFM	AVAILABLE EXTERNAL STATIC PRESSURE (in. wg)									
	1.2		1.4		1.6		1.8		2.0	
	RPM	Vdc	RPM	Vdc	RPM	Vdc	RPM	Vdc	RPM	Vdc
1500	1954	8.2	2078	8.7	2194	9.2	2304	9.6	—	—
1625	1990	8.3	2112	8.8	2227	9.3	2336	9.8	—	—
1750	2028	8.5	2148	9.0	2262	9.5	2370	9.9	—	—
1875	2069	8.7	2186	9.1	2298	9.6	—	—	—	—
2000	2112	8.8	2226	9.3	2336	9.8	—	—	—	—
2125	2157	9.0	2268	9.5	2376	9.9	—	—	—	—
2250	2206	9.2	2313	9.7	—	—	—	—	—	—
2375	2258	9.4	2361	9.9	—	—	—	—	—	—
2500	2312	9.7	—	—	—	—	—	—	—	—

Medium Static 1196-2390 RPM

50FCQA06 THREE PHASE - HIGH STATIC — 5 TON HORIZONTAL SUPPLY (RPM - VDC)

CFM	AVAILABLE EXTERNAL STATIC PRESSURE (in. wg)									
	0.2		0.4		0.6		0.8		1.0	
	RPM	Vdc	RPM	Vdc	RPM	Vdc	RPM	Vdc	RPM	Vdc
1500	1196	4.2	1360	4.8	1525	5.4	1679	5.9	1822	6.4
1625	1271	4.5	1421	5.0	1574	5.6	1721	6.1	1860	6.6
1750	1348	4.8	1485	5.2	1627	5.7	1767	6.2	1901	6.7
1875	1425	5.0	1553	5.5	1684	5.9	1817	6.4	1945	6.9
2000	1504	5.3	1622	5.7	1745	6.2	1870	6.6	1993	7.0
2125	1585	5.6	1695	6.0	1809	6.4	1926	6.8	2043	7.2
2250	1666	5.9	1769	6.2	1876	6.6	1986	7.0	2096	7.4
2375	1747	6.2	1844	6.5	1945	6.9	2049	7.2	2153	7.6
2500	1829	6.4	1921	6.8	2016	7.1	2114	7.5	2213	7.8

CFM	AVAILABLE EXTERNAL STATIC PRESSURE (in. wg)									
	1.2		1.4		1.6		1.8		2.0	
	RPM	Vdc	RPM	Vdc	RPM	Vdc	RPM	Vdc	RPM	Vdc
1500	1954	6.9	2078	7.3	2194	7.7	2304	8.1	2408	8.5
1625	1990	7.0	2112	7.4	2227	7.9	2336	8.2	2439	8.6
1750	2028	7.2	2148	7.6	2262	8.0	2370	8.4	2472	8.7
1875	2069	7.3	2186	7.7	2298	8.1	2404	8.5	2506	8.8
2000	2112	7.4	2226	7.8	2336	8.2	2441	8.6	2541	9.0
2125	2157	7.6	2268	8.0	2376	8.4	2479	8.7	2578	9.1
2250	2206	7.8	2313	8.2	2418	8.5	2518	8.9	2616	9.2
2375	2258	8.0	2361	8.3	2462	8.7	2560	9.0	2656	9.4
2500	2312	8.2	2411	8.5	2508	8.8	2604	9.2	2698	9.5

High Static 1196-2836 RPM

50FCQM07 THREE PHASE — 6 TON HORIZONTAL SUPPLY (RPM - BHP)

CFM	AVAILABLE EXTERNAL STATIC PRESSURE (in. wg)									
	0.2		0.4		0.6		0.8		1.0	
	RPM	BHP	RPM	BHP	RPM	BHP	RPM	BHP	RPM	BHP
1800	1378	0.27	1512	0.35	1649	0.46	1786	0.58	1918	0.72
1950	1473	0.32	1594	0.41	1721	0.52	1848	0.64	1973	0.78
2100	1569	0.39	1680	0.48	1796	0.59	1915	0.71	2032	0.85
2250	1666	0.47	1769	0.56	1876	0.67	1986	0.79	2096	0.93
2400	1764	0.55	1860	0.65	1959	0.76	2061	0.88	2165	1.02
2550	1863	0.65	1952	0.75	2045	0.86	2140	0.99	2237	1.13
2700	1962	0.76	2046	0.86	2133	0.97	2222	1.10	2313	1.24
2850	2062	0.88	2141	0.98	2223	1.10	2307	1.23	2392	1.37
3000	2163	1.01	2238	1.12	2315	1.24	2394	1.37	2474	1.52

CFM	AVAILABLE EXTERNAL STATIC PRESSURE (in. wg)									
	1.2		1.4		1.6		1.8		2.0	
	RPM	BHP	RPM	BHP	RPM	BHP	RPM	BHP	RPM	BHP
1800	2044	0.87	2163	1.03	2276	1.20	2383	1.38	2486	1.57
1950	2094	0.93	2210	1.10	2320	1.27	2426	1.45	2527	1.64
2100	2148	1.00	2259	1.17	2367	1.34	2471	1.53	2570	1.72
2250	2206	1.08	2313	1.25	2417	1.43	2518	1.61	2616	1.81
2400	2268	1.18	2370	1.34	2471	1.52	2568	1.71	2664	1.90
2550	2335	1.28	2432	1.45	2528	1.62	2622	1.81	2714	2.01
2700	2405	1.40	2497	1.56	2589	1.74	2679	1.93	2768	2.13
2850	2479	1.53	2566	1.69	2653	1.87	2740	2.06	2826	2.26
3000	2556	1.67	2639	1.84	2722	2.02	2804	2.21	—	—

Standard Static 1378-2300 RPM, 1.31 Max BHP

Medium Static 1378-2530 RPM, 1.76 Max BHP

High Static 1378-2836 RPM, 2.43 Max BHP

50FCQM07 THREE PHASE - STANDARD STATIC — 6 TON HORIZONTAL SUPPLY (RPM - VDC)

CFM	AVAILABLE EXTERNAL STATIC PRESSURE (in. wg)									
	0.2		0.4		0.6		0.8		1.0	
	RPM	Vdc	RPM	Vdc	RPM	Vdc	RPM	Vdc	RPM	Vdc
1800	1378	6.0	1512	6.6	1649	7.2	1786	7.8	1918	8.3
1950	1473	6.4	1594	6.9	1721	7.5	1848	8.0	1973	8.6
2100	1569	6.8	1680	7.3	1796	7.8	1915	8.3	2032	8.8
2250	1666	7.2	1769	7.7	1876	8.2	1986	8.6	2096	9.1
2400	1764	7.7	1860	8.1	1959	8.5	2061	9.0	2165	9.4
2550	1863	8.1	1952	8.5	2045	8.9	2140	9.3	2237	9.7
2700	1962	8.5	2046	8.9	2133	9.3	2222	9.7	—	—
2850	2062	9.0	2141	9.3	2223	9.7	—	—	—	—
3000	2163	9.4	2238	9.7	—	—	—	—	—	—

CFM	AVAILABLE EXTERNAL STATIC PRESSURE (in. wg)									
	1.2		1.4		1.6		1.8		2.0	
	RPM	Vdc	RPM	Vdc	RPM	Vdc	RPM	Vdc	RPM	Vdc
1800	2044	8.9	2163	9.4	2276	9.9	—	—	—	—
1950	2094	9.1	2210	9.6	—	—	—	—	—	—
2100	2148	9.3	2259	9.8	—	—	—	—	—	—
2250	2206	9.6	—	—	—	—	—	—	—	—
2400	2268	9.9	—	—	—	—	—	—	—	—
2550	—	—	—	—	—	—	—	—	—	—
2700	—	—	—	—	—	—	—	—	—	—
2850	—	—	—	—	—	—	—	—	—	—
3000	—	—	—	—	—	—	—	—	—	—

Standard Static 1378-2300 RPM

50FCQM07 THREE PHASE - MEDIUM STATIC — 6 TON HORIZONTAL SUPPLY (RPM - VDC)

CFM	AVAILABLE EXTERNAL STATIC PRESSURE (in. wg)									
	0.2		0.4		0.6		0.8		1.0	
	RPM	Vdc	RPM	Vdc	RPM	Vdc	RPM	Vdc	RPM	Vdc
1800	1378	5.4	1512	6.0	1649	6.5	1786	7.1	1918	7.6
1950	1473	5.8	1594	6.3	1721	6.8	1848	7.3	1973	7.8
2100	1569	6.2	1680	6.6	1796	7.1	1915	7.6	2032	8.0
2250	1666	6.6	1769	7.0	1876	7.4	1986	7.8	2096	8.3
2400	1764	7.0	1860	7.4	1959	7.7	2061	8.1	2165	8.6
2550	1863	7.4	1952	7.7	2045	8.1	2140	8.5	2237	8.8
2700	1962	7.8	2046	8.1	2133	8.4	2222	8.8	2313	9.1
2850	2062	8.2	2141	8.5	2223	8.8	2307	9.1	2392	9.5
3000	2163	8.5	2238	8.8	2315	9.2	2394	9.5	2474	9.8

CFM	AVAILABLE EXTERNAL STATIC PRESSURE (in. wg)									
	1.2		1.4		1.6		1.8		2.0	
	RPM	Vdc	RPM	Vdc	RPM	Vdc	RPM	Vdc	RPM	Vdc
1800	2044	8.1	2163	8.5	2276	9.0	2383	9.4	2486	9.8
1950	2094	8.3	2210	8.7	2320	9.2	2426	9.6	2527	10.0
2100	2148	8.5	2259	8.9	2367	9.4	2471	9.8	—	—
2250	2206	8.7	2313	9.1	2417	9.6	2518	10.0	—	—
2400	2268	9.0	2370	9.4	2471	9.8	—	—	—	—
2550	2335	9.2	2432	9.6	2528	10.0	—	—	—	—
2700	2405	9.5	2497	9.9	—	—	—	—	—	—
2850	2479	9.8	—	—	—	—	—	—	—	—
3000	—	—	—	—	—	—	—	—	—	—

Medium Static 1378-2530 RPM

50FCQM07 THREE PHASE - HIGH STATIC — 6 TON HORIZONTAL SUPPLY (RPM - VDC)

CFM	AVAILABLE EXTERNAL STATIC PRESSURE (in. wg)									
	0.2		0.4		0.6		0.8		1.0	
	RPM	Vdc	RPM	Vdc	RPM	Vdc	RPM	Vdc	RPM	Vdc
1800	1378	4.9	1512	5.3	1649	5.8	1786	6.3	1918	6.8
1950	1473	5.2	1594	5.6	1721	6.1	1848	6.5	1973	7.0
2100	1569	5.5	1680	5.9	1796	6.3	1915	6.8	2032	7.2
2250	1666	5.9	1769	6.2	1876	6.6	1986	7.0	2096	7.4
2400	1764	6.2	1860	6.6	1959	6.9	2061	7.3	2165	7.6
2550	1863	6.6	1952	6.9	2045	7.2	2140	7.5	2237	7.9
2700	1962	6.9	2046	7.2	2133	7.5	2222	7.8	2313	8.2
2850	2062	7.3	2141	7.5	2223	7.8	2307	8.1	2392	8.4
3000	2163	7.6	2238	7.9	2315	8.2	2394	8.4	2474	8.7

CFM	AVAILABLE EXTERNAL STATIC PRESSURE (in. wg)									
	1.2		1.4		1.6		1.8		2.0	
	RPM	Vdc	RPM	Vdc	RPM	Vdc	RPM	Vdc	RPM	Vdc
1800	2044	7.2	2163	7.6	2276	8.0	2383	8.4	2486	8.8
1950	2094	7.4	2210	7.8	2320	8.2	2426	8.6	2527	8.9
2100	2148	7.6	2259	8.0	2367	8.3	2471	8.7	2570	9.1
2250	2206	7.8	2313	8.2	2417	8.5	2518	8.9	2616	9.2
2400	2268	8.0	2370	8.4	2471	8.7	2568	9.1	2664	9.4
2550	2335	8.2	2432	8.6	2528	8.9	2622	9.2	2714	9.6
2700	2405	8.5	2497	8.8	2589	9.1	2679	9.4	2768	9.8
2850	2479	8.7	2566	9.0	2653	9.4	2740	9.7	2826	10.0
3000	2556	9.0	2639	9.3	2722	9.6	2804	9.9	—	—

High Static 1378-2836 RPM

Legend and Notes

Applicable for Electrical Data Tables on pages 59 to 80

LEGEND

BRKR	— Circuit Breaker
C.O.	— Convenience Outlet
FLA	— Full Load Amps
IFM	— Indoor Fan Motor
LRA	— Locked Rotor Amps
MCA	— Minimum Circuit Amps
P.E.	— Power Exhaust
PWRD C.O.	— Powered Convenience Outlet
RLA	— Rated Load Amps
UNPWR C.O.	— Unpowered Convenience Outlet

NOTES:

1. In compliance with NEC requirements for multi-motor and combination load equipment (refer to NEC Articles 430 and 440), the overcurrent protective device for the unit shall be fuse or HACR breaker. Canadian units may be fuse or circuit breaker.
2. For 208/230 v units, where one value is show it is the same for either 208 or 230 volts.
3. **Unbalanced 3-Phase Supply Voltage**
Never operate a motor where a phase imbalance in supply voltage is greater than 2%. Use the following formula to determine the percentage of voltage imbalance.

$$\% \text{ Voltage Imbalance} = 100 \times \frac{\text{max voltage deviation from average voltage}}{\text{average voltage}}$$

Example: Supply voltage is 230-3-60

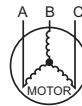

AB = 224 v
BC = 231 v
AC = 226 v

$$\text{Average Voltage} = \frac{(224 + 231 + 226)}{3} = \frac{681}{3} = 227$$

Determine maximum deviation from average voltage.

(AB) 227-224 = 3 v

(BC) 231-227 = 4 v

(AC) 227-226 = 1 v

Maximum deviation is 4 v.

Determine percent of voltage imbalance.

$$\% \text{ Voltage Imbalance} = 100 \times \frac{4}{227} = 1.78\%$$

This amount of phase imbalance is satisfactory as it is below the maximum allowable 2%.

IMPORTANT: If the supply voltage phase imbalance is more than 2%, contact your local electric utility company immediately.



50FCQ*04-07 COOLING ELECTRICAL DATA

50FCQ UNIT	V-Ph-Hz	UNIT VOLTAGE		COMPRESSOR		OFM (EA)		IFM			POWER EXHAUST		
		RANGE		RLA	LRA	WATTS	FLA	TYPE	EFFICIENCY AT FULL LOAD	FLA	KIT QTY	FLA (EA KIT)	
		MIN	MAX										
A04	208-1-60	187	253	15.4	84	190	1.5	STD	84%	4.3	1	1.9	
								MED	84%	5.1			
								HIGH	85%	7.3			
	230-1-60	187	253	15.4	84	190	1.5	1.5	STD	84%	4.3	1	1.9
									MED	84%	5.1		
									HIGH	85%	7.3		
	208-3-60	187	253	10.4	73	190	1.5	1.5	STD	84%	4.3	1	1.9
									MED	84%	5.1		
									HIGH	85%	7.3		
	230-3-60	187	253	10.4	73	190	1.5	1.5	STD	84%	4.3	1	1.9
									MED	84%	5.1		
									HIGH	85%	7.3		
	460-3-60	414	506	5.8	38	190	0.8	0.8	STD	85%	1.2	1	1.0
									MED	85%	1.2		
									HIGH	84%	1.7		
	575-3-60	518	633	3.8	37	190	0.6	0.6	STD	84%	1.1	1	1.9
									MED	84%	1.1		
									HIGH	85%	1.5		
A05	208-1-60	187	253	19.8	130	325	1.5	STD	87%	5.0	1	1.9	
								MED	86%	7.1			
								HIGH	84%	9.2			
	230-1-60	187	253	19.8	130	325	1.5	1.5	STD	87%	5.0	1	1.9
									MED	86%	7.1		
									HIGH	84%	9.2		
	208-3-60	187	253	13.7	83	325	1.5	1.5	STD	87%	5.0	1	1.9
									MED	86%	7.1		
									HIGH	85%	5.5		
	230-3-60	187	253	13.7	83	325	1.5	1.5	STD	87%	5.0	1	1.9
									MED	86%	7.1		
									HIGH	85%	5.5		
	460-3-60	414	506	6.2	41	325	0.8	0.8	STD	85%	1.2	1	1.0
									MED	86%	1.7		
									HIGH	88%	2.6		
	575-3-60	518	633	4.8	33	325	0.6	0.6	STD	84%	1.1	1	1.9
									MED	85%	1.5		
									HIGH	88%	2.3		
A06	208-1-60	187	253	24.4	144	325	1.5	STD	86%	7.2	1	1.9	
								MED	84%	9.2			
								HIGH	87%	11.7			
	230-1-60	187	253	24.4	144	325	1.5	1.5	STD	86%	7.2	1	1.9
									MED	84%	9.2		
									HIGH	87%	11.7		
	208-3-60	187	253	16.0	110	325	1.5	1.5	STD	86%	7.2	1	1.9
									MED	84%	9.2		
									HIGH	84%	6.5		
	230-3-60	187	253	16.0	110	325	1.5	1.5	STD	86%	7.2	1	1.9
									MED	84%	9.2		
									HIGH	84%	6.5		
	460-3-60	414	506	7.8	52	325	0.8	0.8	STD	86%	1.7	1	1.0
									MED	86%	2.1		
									HIGH	88%	3.1		
	575-3-60	518	633	5.7	39	325	0.6	0.6	STD	84%	1.5	1	1.9
									MED	85%	2.0		
									HIGH	87%	2.7		

Electrical data (cont)



50FCQ*04-07 COOLING ELECTRICAL DATA (cont)

50FCQ UNIT	V-Ph-Hz	UNIT VOLTAGE		COMPRESSOR		OFM (EA)		IFM			POWER EXHAUST	
		RANGE		RLA	LRA	WATTS	FLA	TYPE	EFFICIENCY AT FULL LOAD	FLA	KIT QTY	FLA (EA KIT)
		MIN	MAX									
M07	208-3-60	187	253	18.0	136	325	1.5	STD	84%	9.2	1	1.9
								MED	87%	5.5		
								HIGH	84%	6.5		
	230-3-60	187	253	18.0	136	325	1.5	STD	84%	9.2	1	1.9
								MED	87%	5.5		
								HIGH	84%	6.5		
	460-3-60	414	506	8.5	66	325	0.8	STD	85%	2.1	1	1.0
								MED	88%	2.6		
								HIGH	88%	3.1		
	575-3-60	518	633	7.3	55	325	0.6	STD	85%	2.0	1	1.9
								MED	88%	2.3		
								HIGH	87%	2.7		



50FCQA04 MCA MOCPS ELECTRICAL DATA

50FCQ UNIT SIZE	NOM. V-Ph-Hz	IFM TYPE	ELECTRIC HEATER			NO CONVENIENCE OUTLET or UNPOWERED CONVENIENCE OUTLET							
			CRHEATER ****00	NOM (kW)	FLA	NO POWER EXHAUST				w/ POWER EXHAUST (powered from unit)			
						MCA	FUSE OR HACR BRKR	DISCONNECT SIZE		MCA	FUSE OR HACR BRKR	DISCONNECT SIZE	
								FLA	LRA			FLA	LRA
A04	208/230-1-60	STD	NONE	—	—	26	30	24	94	27	40	27	96
			323A	3.3/4.4	15.9/18.3	45/48	50/50	43/45	110/112	47/50	50/60	45/48	112/114
			324A	4.9/6.5	23.5/27.1	55/59	60/60	51/56	118/121	57/61	60/70	54/58	120/123
			325A	6.5/8.7	31.4/36.3	65/71	70/80	60/66	125/130	67/73	70/80	63/68	127/132
			326A	7.9/10.5	37.9/43.8	73/80	80/80	68/75	132/138	75/82	80/90	70/77	134/140
		327A	9.8/13.0	46.9/54.2	84/93	90/100	78/87	141/148	86/95	90/100	81/89	143/150	
		MED	NONE	—	—	26	30	25	95	28	40	27	97
			323A	3.3/4.4	15.9/18.3	46/49	50/50	44/46	111/113	48/51	50/60	46/49	113/115
			324A	4.9/6.5	23.5/27.1	56/60	60/60	52/56	119/122	58/62	60/70	55/59	121/124
			325A	6.5/8.7	31.4/36.3	66/72	70/80	61/67	126/131	67/74	70/80	64/69	128/133
			326A	7.9/10.5	37.9/43.8	74/81	80/90	69/76	133/139	76/83	80/90	71/78	135/141
		HIGH	NONE	—	—	29	40	28	98	30	45	30	100
	323A		3.3/4.4	15.9/18.3	48/51	50/60	46/49	114/116	50/53	60/60	48/51	116/118	
	324A		4.9/6.5	23.5/27.1	58/62	60/70	55/59	122/125	60/64	60/70	57/61	124/127	
	325A		6.5/8.7	31.4/36.3	68/74	70/80	64/70	129/134	70/76	70/80	66/72	131/136	
	326A		7.9/10.5	37.9/43.8	76/83	80/90	71/78	136/142	78/85	80/90	74/80	138/144	
	208/230-3-60	STD	NONE	—	—	19	25	19	83	21	30	21	85
			323A	3.3/4.4	9.2/10.6	31/33	35/35	29/31	92/94	33/34	40/40	31/33	94/96
			324A	4.9/6.5	13.6/15.6	36/39	40/40	34/37	97/99	38/41	40/45	36/39	99/101
			325A	6.5/8.7	18.1/20.9	42/45	45/50	39/43	101/104	44/47	45/50	42/45	103/106
			326A	7.9/10.5	21.9/25.3	47/51	50/60	44/48	105/108	49/53	50/60	46/50	107/110
		328A	12.0/16.0	33.4/38.5	61/67	70/70	57/63	116/122	63/69	70/70	59/65	118/124	
		MED	NONE	—	—	20	30	20	84	22	30	22	86
			323A	3.3/4.4	9.2/10.6	32/33	35/40	30/32	93/95	33/35	40/40	32/34	95/97
			324A	4.9/6.5	13.6/15.6	37/40	40/45	35/37	98/100	39/41	45/45	37/40	100/102
			325A	6.5/8.7	18.1/20.9	43/46	45/50	40/44	102/105	45/48	50/50	43/46	104/107
			326A	7.9/10.5	21.9/25.3	47/52	50/60	45/49	106/109	49/54	50/60	47/51	108/111
		328A	12.0/16.0	33.4/38.5	62/68	70/70	58/64	117/123	64/70	70/70	60/66	119/125	
	HIGH	NONE	—	—	22	30	22	87	24	30	24	89	
		323A	3.3/4.4	9.2/10.6	34/36	40/40	33/34	96/98	36/37	40/40	35/36	98/100	
		324A	4.9/6.5	13.6/15.6	39/42	45/45	38/40	101/103	41/44	45/45	40/42	103/105	
		325A	6.5/8.7	18.1/20.9	45/48	50/50	43/46	105/108	47/50	50/50	45/48	107/110	
		326A	7.9/10.5	21.9/25.3	50/54	50/60	47/51	109/112	52/56	60/60	49/53	111/114	
	328A	12.0/16.0	33.4/38.5	64/70	70/70	60/66	120/126	66/72	70/80	63/69	122/128		
	460-3-60	STD	NONE	—	—	10	15	9	42	11	15	10	43
			333A	6.0	7.2	19	20	17	49	20	20	18	50
			334A	8.8	10.6	23	25	21	53	24	25	22	54
			335A	11.5	13.8	27	30	25	56	28	30	26	57
			336A	14.0	16.8	31	35	28	59	32	35	29	60
		MED	NONE	—	—	10	15	9	42	11	15	10	43
			333A	6.0	7.2	19	20	17	49	20	20	18	50
			334A	8.8	10.6	23	25	21	53	24	25	22	54
			335A	11.5	13.8	27	30	25	56	28	30	26	57
			336A	14.0	16.8	31	35	28	59	32	35	29	60
		HIGH	NONE	—	—	10	15	10	42	11	15	11	43
			333A	6.0	7.2	19	20	18	49	20	20	19	50
	334A		8.8	10.6	23	25	22	53	24	25	23	54	
	335A		11.5	13.8	27	30	25	56	28	30	27	57	
336A	14.0		16.8	31	35	29	59	32	35	30	60		
575-3-60	STD	NONE	—	—	7	15	6	41	9	15	9	43	
		339A	10.0	9.6	19	20	17	51	21	25	20	53	
		340A	15.0	14.4	25	25	23	55	27	30	25	57	
	MED	NONE	—	—	7	15	6	41	9	15	9	43	
		339A	10.0	9.6	19	20	17	51	21	25	20	53	
		340A	15.0	14.4	25	25	23	55	27	30	25	57	
	HIGH	NONE	—	—	7	15	7	41	9	15	9	43	
		339A	10.0	9.6	19	20	18	51	21	25	20	53	
		340A	15.0	14.4	25	25	23	55	27	30	26	57	

50FCQA04 MCA MOCP ELECTRICAL DATA (cont)

50FCQ UNIT SIZE	NOM. V-Ph-Hz	IFM TYPE	ELECTRIC HEATER			w/ POWERED CONVENIENCE OUTLET									
			CRHEATER ****00	NOM (kW)	FLA	NO POWER EXHAUST				w/ POWER EXHAUST (powered from unit)					
						MCA	FUSE OR HACR BRKR	DISCONNECT SIZE		MCA	FUSE OR HACR BRKR	DISCONNECT SIZE			
							FLA	LRA			FLA	LRA			
A04	208/230-1-60	STD	NONE	—	—	—	—	—	—	—	—	—	—	—	
			323A	3.3/4.4	15.9/18.3	—	—	—	—	—	—	—	—	—	—
			324A	4.9/6.5	23.5/27.1	—	—	—	—	—	—	—	—	—	—
			325A	6.5/8.7	31.4/36.3	—	—	—	—	—	—	—	—	—	—
			326A	7.9/10.5	37.9/43.8	—	—	—	—	—	—	—	—	—	—
			327A	9.8/13.0	46.9/54.2	—	—	—	—	—	—	—	—	—	—
		MED	NONE	—	—	—	—	—	—	—	—	—	—	—	—
			323A	3.3/4.4	15.9/18.3	—	—	—	—	—	—	—	—	—	—
			324A	4.9/6.5	23.5/27.1	—	—	—	—	—	—	—	—	—	—
			325A	6.5/8.7	31.4/36.3	—	—	—	—	—	—	—	—	—	—
			326A	7.9/10.5	37.9/43.8	—	—	—	—	—	—	—	—	—	—
			327A	9.8/13.0	46.9/54.2	—	—	—	—	—	—	—	—	—	—
		HIGH	NONE	—	—	—	—	—	—	—	—	—	—	—	—
			323A	3.3/4.4	15.9/18.3	—	—	—	—	—	—	—	—	—	—
			324A	4.9/6.5	23.5/27.1	—	—	—	—	—	—	—	—	—	—
			325A	6.5/8.7	31.4/36.3	—	—	—	—	—	—	—	—	—	—
			326A	7.9/10.5	37.9/43.8	—	—	—	—	—	—	—	—	—	—
			327A	9.8/13.0	46.9/54.2	—	—	—	—	—	—	—	—	—	—
	208/230-3-60	STD	NONE	—	—	24	30	24	88	26	30	26	90		
			323A	3.3/4.4	9.2/10.6	36/37	40/40	35/36	97/99	37/39	45/45	37/39	99/101		
			324A	4.9/6.5	13.6/15.6	41/44	45/45	40/42	102/104	43/45	45/50	42/44	104/106		
			325A	6.5/8.7	18.1/20.9	47/50	50/50	45/48	106/109	49/52	50/60	47/50	108/111		
			326A	7.9/10.5	21.9/25.3	51/56	60/60	49/53	110/113	53/58	60/60	52/55	112/115		
			328A	12.0/16.0	33.4/38.5	66/72	70/80	63/68	121/127	68/74	70/80	65/71	123/129		
		MED	NONE	—	—	25	30	25	89	27	30	27	91		
			323A	3.3/4.4	9.2/10.6	36/38	40/45	36/37	98/100	38/40	45/45	38/39	100/102		
			324A	4.9/6.5	13.6/15.6	42/44	45/50	41/43	103/105	44/46	50/50	43/45	105/107		
			325A	6.5/8.7	18.1/20.9	47/51	50/60	46/49	107/110	49/53	50/60	48/51	109/112		
			326A	7.9/10.5	21.9/25.3	52/56	60/60	50/54	111/114	54/58	60/60	52/56	113/116		
			328A	12.0/16.0	33.4/38.5	67/73	70/80	63/69	122/128	69/75	70/80	66/72	124/130		
		HIGH	NONE	—	—	27	30	28	92	29	35	30	94		
			323A	3.3/4.4	9.2/10.6	39/40	45/45	38/40	101/103	40/42	45/45	40/42	103/105		
			324A	4.9/6.5	13.6/15.6	44/47	50/50	43/46	106/108	46/48	50/50	45/48	108/110		
			325A	6.5/8.7	18.1/20.9	50/53	50/60	48/52	110/113	52/55	60/60	51/54	112/115		
			326A	7.9/10.5	21.9/25.3	54/59	60/60	53/57	114/117	56/61	60/70	55/59	116/119		
			328A	12.0/16.0	33.4/38.5	69/75	70/80	66/72	125/131	71/77	80/80	68/74	127/133		
460-3-60	STD	NONE	—	—	12	15	12	44	13	15	13	45			
		333A	6.0	7.2	21	25	20	51	22	25	21	52			
		334A	8.8	10.6	25	25	24	55	26	30	25	56			
		335A	11.5	13.8	29	30	27	58	30	30	29	59			
		336A	14.0	16.8	33	35	31	61	34	35	32	62			
		NONE	—	—	12	15	12	44	13	15	13	45			
	MED	333A	6.0	7.2	21	25	20	51	22	25	21	52			
		334A	8.8	10.6	25	25	24	55	26	30	25	56			
		335A	11.5	13.8	29	30	27	58	30	30	29	59			
		336A	14.0	16.8	33	35	31	61	34	35	32	62			
		NONE	—	—	12	15	12	44	13	15	13	45			
		333A	6.0	7.2	21	25	20	51	22	25	21	52			
	HIGH	334A	8.8	10.6	26	30	24	55	27	30	25	56			
		335A	11.5	13.8	30	30	28	58	31	35	29	59			
		336A	14.0	16.8	33	35	31	61	34	35	33	62			
		NONE	—	—	9	15	8	43	11	15	10	45			
		339A	10.0	9.6	21	25	19	53	23	25	22	55			
		340A	15.0	14.4	27	30	25	57	29	30	27	59			
575-3-60	STD	NONE	—	—	9	15	8	43	11	15	10	45			
		339A	10.0	9.6	21	25	19	53	23	25	22	55			
		340A	15.0	14.4	27	30	25	57	29	30	27	59			
	MED	NONE	—	—	9	15	8	43	11	15	10	45			
		339A	10.0	9.6	21	25	19	53	23	25	22	55			
		340A	15.0	14.4	27	30	25	57	29	30	27	59			
HIGH	NONE	—	—	9	15	9	43	11	15	11	45				
	339A	10.0	9.6	21	25	20	53	23	25	22	55				
	340A	15.0	14.4	27	30	25	57	29	30	27	59				



50FCQA05 MCA MOCP ELECTRICAL DATA

50FCQ UNIT SIZE	NOM. V-Ph-Hz	IFM TYPE	ELECTRIC HEATER			NO CONVENIENCE OUTLET or UNPOWERED CONVENIENCE OUTLET									
			CRHEATER ****00	NOM (kW)	FLA	NO POWER EXHAUST			w/ POWER EXHAUST (powered from unit)						
						MCA	FUSE OR HACR BRKR	DISCONNECT SIZE		MCA	FUSE OR HACR BRKR	DISCONNECT SIZE			
			FLA	LRA					FLA			LRA			
208/230-1-60		STD	NONE	—	—	32	50	30	141	34	50	32	143		
			323A	3.3/4.4	15.9/18.3	52/55	60/60	49/51	157/159	53/56	60/60	51/53	159/161		
			325A	6.5/8.7	31.4/36.3	71/77	80/80	66/72	172/177	73/79	80/80	69/74	174/179		
			327A	9.8/13.0	46.9/54.2	90/99	90/100	84/93	188/195	92/101	100/110	86/95	190/197		
			329A	13.1/17.4	62.8/72.5	110/122	110/125	102/114	204/214	112/124	125/125	105/116	206/216		
			330A	14.4/19.2	69.3/80.0	118/132	125/150	110/122	210/221	120/134	125/150	112/124	212/223		
		331A	15.8/21.0	75.8/87.5	126/141	150/150	117/131	217/229	128/143	150/150	120/133	219/231			
		MED	NONE	—	—	34	50	33	144	36	50	35	146		
			323A	3.3/4.4	15.9/18.3	54/57	60/60	51/54	160/162	56/59	60/60	53/56	162/164		
			325A	6.5/8.7	31.4/36.3	73/79	80/80	69/74	175/180	75/81	80/90	71/77	177/182		
			327A	9.8/13.0	46.9/54.2	92/102	100/110	87/95	191/198	94/103	100/110	89/97	193/200		
			329A	13.1/17.4	62.8/72.5	112/124	125/125	105/116	207/217	114/126	125/150	107/118	209/219		
			330A	14.4/19.2	69.3/80.0	120/134	125/150	112/125	213/224	122/136	125/150	115/127	215/226		
		331A	15.8/21.0	75.8/87.5	129/143	150/150	120/133	220/232	130/145	150/150	122/135	222/234			
		HIGH	NONE	—	—	36	50	35	147	38	50	37	149		
			323A	3.3/4.4	15.9/18.3	56/59	60/60	53/56	163/165	58/61	60/70	56/58	165/167		
			325A	6.5/8.7	31.4/36.3	75/81	80/90	71/77	178/183	77/83	80/90	73/79	180/185		
			327A	9.8/13.0	46.9/54.2	95/104	100/110	89/97	194/201	96/106	100/110	91/100	196/203		
			329A	13.1/17.4	62.8/72.5	114/127	125/150	107/118	210/220	116/128	125/150	109/121	212/222		
			330A	14.4/19.2	69.3/80.0	123/136	125/150	115/127	216/227	124/138	125/150	117/129	218/229		
		331A	15.8/21.0	75.8/87.5	131/145	150/150	122/136	223/235	133/147	150/150	124/138	225/237			
		A05 208/230-3-60		STD	NONE	—	—	24	30	23	94	26	30	25	96
					323A	3.3/4.4	9.2/10.6	36/37	45/45	34/35	103/105	37/39	45/45	36/38	105/107
					324A	4.9/6.5	13.6/15.6	41/44	50/50	39/41	108/110	43/45	50/50	41/43	110/112
325A	6.5/8.7				18.1/20.9	47/50	50/50	44/47	112/115	49/52	50/60	46/49	114/117		
328A	12.0/16.0				33.4/38.5	66/72	70/80	62/68	127/133	68/74	70/80	64/70	129/135		
330A	14.4/19.2				40.0/46.2	74/82	80/90	69/76	134/140	76/84	80/90	71/79	136/142		
331A	15.8/21.0			43.8/50.5	79/87	80/90	74/81	138/145	81/89	90/90	76/83	140/147			
MED	NONE			—	—	26	30	26	97	28	40	28	99		
	323A			3.3/4.4	9.2/10.6	38/39	45/50	36/38	106/108	40/41	50/50	38/40	108/110		
	324A			4.9/6.5	13.6/15.6	43/46	50/50	41/44	111/113	45/48	50/50	43/46	113/115		
	325A			6.5/8.7	18.1/20.9	49/52	50/60	46/50	115/118	51/54	60/60	49/52	117/120		
	328A			12.0/16.0	33.4/38.5	68/74	70/80	64/70	130/136	70/76	70/80	66/72	132/138		
	330A			14.4/19.2	40.0/46.2	76/84	80/90	72/79	137/143	78/86	80/90	74/81	139/145		
331A	15.8/21.0			43.8/50.5	81/89	90/90	76/84	141/148	83/91	90/100	78/86	143/150			
HIGH	NONE			—	—	25	30	24	95	26	30	26	97		
	323A			3.3/4.4	9.2/10.6	36/38	45/45	34/36	104/106	38/40	45/50	37/38	106/108		
	324A			4.9/6.5	13.6/15.6	42/44	50/50	39/42	109/111	43/46	50/50	42/44	111/113		
	325A			6.5/8.7	18.1/20.9	47/51	50/60	45/48	113/116	49/53	50/60	47/50	115/118		
	328A			12.0/16.0	33.4/38.5	66/73	70/80	62/68	128/134	68/75	70/80	64/70	130/136		
	330A			14.4/19.2	40.0/46.2	75/82	80/90	70/77	135/141	76/84	80/90	72/79	137/143		
331A	15.8/21.0			43.8/50.5	79/88	80/90	74/82	139/146	81/90	90/90	76/84	141/148			
460-3-60				STD	NONE	—	—	10	15	9	45	11	15	11	46
					333A	6.0	7.2	19	20	18	52	20	20	19	53
					335A	11.5	13.8	27	30	25	59	28	30	26	60
		336A	14.0		16.8	31	35	29	62	32	35	30	63		
		337A	21.5		25.9	43	45	39	71	44	45	40	72		
		MED	NONE	—	—	11	15	10	45	12	15	11	46		
			333A	6.0	7.2	20	20	18	52	21	25	19	53		
			335A	11.5	13.8	28	30	26	59	29	30	27	60		
			336A	14.0	16.8	32	35	29	62	33	35	30	63		
		337A	21.5	25.9	43	45	40	71	44	45	41	72			
		HIGH	NONE	—	—	12	15	11	47	13	15	12	48		
			333A	6.0	7.2	21	25	19	54	22	25	20	55		
			335A	11.5	13.8	29	30	27	61	30	30	28	62		
			336A	14.0	16.8	33	35	30	64	34	35	32	65		
			337A	21.5	25.9	44	45	41	73	45	45	42	74		

Electrical data (cont)



50FCQA05 MCA MOCP ELECTRICAL DATA (cont)

50FCQ UNIT SIZE	NOM. V-Ph-Hz	IFM TYPE	ELECTRIC HEATER			NO CONVENIENCE OUTLET or UNPOWERED CONVENIENCE OUTLET							
			CRHEATER ****00	NOM (kW)	FLA	NO POWER EXHAUST				w/ POWER EXHAUST (powered from unit)			
						MCA	FUSE OR HACR BRKR	DISCONNECT SIZE		MCA	FUSE OR HACR BRKR	DISCONNECT SIZE	
FLA	LRA	FLA	LRA										
A05 (cont)	575-3-60	STD	NONE	—	—	8	15	7	37	10	15	10	39
			339A	10.0	9.6	20	20	19	47	22	25	21	49
			340A	15.0	14.4	26	30	24	51	28	30	26	53
		MED	NONE	—	—	9	15	8	37	10	15	10	39
			339A	10.0	9.6	21	25	19	47	22	25	21	49
			340A	15.0	14.4	27	30	24	51	28	30	27	53
		HIGH	NONE	—	—	9	15	9	38	11	15	11	40
			339A	10.0	9.6	21	25	20	48	23	25	22	50
			340A	15.0	14.4	27	30	25	52	29	30	28	54



50FCQA05 MCA MOCP ELECTRICAL DATA (cont)

50FCQ UNIT SIZE	NOM. V-Ph-Hz	IFM TYPE	ELECTRIC HEATER			w/ POWERED CONVENIENCE OUTLET								
			CRHEATER ****00	NOM (kW)	FLA	NO POWER EXHAUST				w/ POWER EXHAUST (powered from unit)				
						MCA	FUSE OR HACR BRKR	DISCONNECT SIZE		MCA	FUSE OR HACR BRKR	DISCONNECT SIZE		
								FLA	LRA			FLA	LRA	
A05	208/230-1-60	STD	NONE	—	—	—	—	—	—	—	—	—	—	—
			323A	3.3/4.4	15.9/18.3	—	—	—	—	—	—	—	—	—
			325A	6.5/8.7	31.4/36.3	—	—	—	—	—	—	—	—	—
			327A	9.8/13.0	46.9/54.2	—	—	—	—	—	—	—	—	—
			329A	13.1/17.4	62.8/72.5	—	—	—	—	—	—	—	—	—
			330A	14.4/19.2	69.3/80.0	—	—	—	—	—	—	—	—	—
		331A	15.8/21.0	75.8/87.5	—	—	—	—	—	—	—	—	—	
		MED	NONE	—	—	—	—	—	—	—	—	—	—	—
			323A	3.3/4.4	15.9/18.3	—	—	—	—	—	—	—	—	—
			325A	6.5/8.7	31.4/36.3	—	—	—	—	—	—	—	—	—
			327A	9.8/13.0	46.9/54.2	—	—	—	—	—	—	—	—	—
			329A	13.1/17.4	62.8/72.5	—	—	—	—	—	—	—	—	—
			330A	14.4/19.2	69.3/80.0	—	—	—	—	—	—	—	—	—
		331A	15.8/21.0	75.8/87.5	—	—	—	—	—	—	—	—	—	
		HIGH	NONE	—	—	—	—	—	—	—	—	—	—	—
			323A	3.3/4.4	15.9/18.3	—	—	—	—	—	—	—	—	—
			325A	6.5/8.7	31.4/36.3	—	—	—	—	—	—	—	—	—
			327A	9.8/13.0	46.9/54.2	—	—	—	—	—	—	—	—	—
	329A		13.1/17.4	62.8/72.5	—	—	—	—	—	—	—	—	—	
	330A		14.4/19.2	69.3/80.0	—	—	—	—	—	—	—	—	—	
	331A	15.8/21.0	75.8/87.5	—	—	—	—	—	—	—	—	—		
	208/230-3-60	STD	NONE	—	—	29	40	29	99	31	40	31	101	
			323A	3.3/4.4	9.2/10.6	40/42	50/50	39/41	108/110	42/44	50/50	42/43	110/112	
			324A	4.9/6.5	13.6/15.6	46/48	50/50	44/47	113/115	48/50	50/50	47/49	115/117	
			325A	6.5/8.7	18.1/20.9	52/55	60/60	50/53	117/120	53/57	60/60	52/55	119/122	
			328A	12.0/16.0	33.4/38.5	71/77	80/80	67/73	132/138	73/79	80/80	69/75	134/140	
			330A	14.4/19.2	40.0/46.2	79/87	80/90	75/82	139/145	81/89	90/90	77/84	141/147	
		331A	15.8/21.0	43.8/50.5	84/92	90/100	79/87	143/150	86/94	90/100	81/89	145/152		
		MED	NONE	—	—	31	40	31	102	33	45	33	104	
			323A	3.3/4.4	9.2/10.6	42/44	50/50	42/43	111/113	44/46	50/50	44/46	113/115	
			324A	4.9/6.5	13.6/15.6	48/50	50/60	47/49	116/118	50/52	50/60	49/51	118/120	
			325A	6.5/8.7	18.1/20.9	54/57	60/60	52/55	120/123	56/59	60/60	54/57	122/125	
			328A	12.0/16.0	33.4/38.5	73/79	80/80	70/75	135/141	75/81	80/90	72/78	137/143	
			330A	14.4/19.2	40.0/46.2	81/89	90/90	77/84	142/148	83/91	90/100	79/86	144/150	
		331A	15.8/21.0	43.8/50.5	86/94	90/100	82/89	146/153	88/96	90/100	84/91	148/155		
		HIGH	NONE	—	—	29	40	29	100	31	40	32	102	
			323A	3.3/4.4	9.2/10.6	41/43	50/50	40/42	109/111	43/45	50/50	42/44	111/113	
			324A	4.9/6.5	13.6/15.6	46/49	50/50	45/47	114/116	48/51	50/60	47/49	116/118	
			325A	6.5/8.7	18.1/20.9	52/56	60/60	50/53	118/121	54/57	60/60	52/56	120/123	
	328A		12.0/16.0	33.4/38.5	71/78	80/80	68/74	133/139	73/79	80/80	70/76	135/141		
	330A		14.4/19.2	40.0/46.2	79/87	80/90	75/82	140/146	81/89	90/90	78/85	142/148		
	331A	15.8/21.0	43.8/50.5	84/93	90/100	80/87	144/151	86/94	90/100	82/90	146/153			
460-3-60	STD	NONE	—	—	12	15	12	47	13	15	13	48		
		333A	6.0	7.2	21	25	20	54	22	25	21	55		
		335A	11.5	13.8	30	30	28	61	31	35	29	62		
		336A	14.0	16.8	33	35	31	64	34	35	32	65		
		337A	21.5	25.9	45	45	42	73	46	50	43	74		
	MED	NONE	—	—	13	15	13	47	14	20	14	48		
		333A	6.0	7.2	22	25	21	54	23	25	22	55		
		335A	11.5	13.8	30	30	28	61	31	35	30	62		
		336A	14.0	16.8	34	35	32	64	35	35	33	65		
		337A	21.5	25.9	45	45	42	73	46	50	43	74		
	HIGH	NONE	—	—	14	15	14	49	15	20	15	50		
		333A	6.0	7.2	23	25	22	56	24	25	23	57		
		335A	11.5	13.8	31	35	29	63	32	35	31	64		
		336A	14.0	16.8	35	35	33	66	36	40	34	67		
		337A	21.5	25.9	46	50	43	75	47	50	45	76		

Electrical data (cont)



50FCQA05 MCA MOCAP ELECTRICAL DATA (cont)

50FCQ UNIT SIZE	NOM. V-Ph-Hz	IFM TYPE	ELECTRIC HEATER			w/ POWERED CONVENIENCE OUTLET							
			CRHEATER ****00	NOM (kW)	FLA	NO POWER EXHAUST				w/ POWER EXHAUST (powered from unit)			
						MCA	FUSE OR HACR BRKR	DISCONNECT SIZE		MCA	FUSE OR HACR BRKR	DISCONNECT SIZE	
FLA	LRA	FLA	LRA										
A05 (cont)	575-3-60	STD	NONE	—	—	10	15	9	39	12	15	12	41
			339A	10.0	9.6	22	25	20	49	24	25	23	51
			340A	15.0	14.4	28	30	26	53	30	30	28	55
		MED	NONE	—	—	10	15	10	39	12	15	12	41
			339A	10.0	9.6	22	25	21	49	24	25	23	51
			340A	15.0	14.4	28	30	26	53	30	30	29	55
		HIGH	NONE	—	—	11	15	11	40	13	15	13	42
			339A	10.0	9.6	23	25	22	50	25	25	24	52
			340A	15.0	14.4	29	30	27	54	31	35	30	56



50FCQA06 MCA MOCPP ELECTRICAL DATA

50FCQ UNIT SIZE	NOM. V-Ph-Hz	IFM TYPE	ELECTRIC HEATER			NO CONVENIENCE OUTLET or UNPOWERED CONVENIENCE OUTLET								
			CRHEATER ****00	NOM (kW)	FLA	NO POWER EXHAUST				w/ POWER EXHAUST (powered from unit)				
						MCA	FUSE OR HACR BRKR	DISCONNECT SIZE		MCA	FUSE OR HACR BRKR	DISCONNECT SIZE		
								FLA	LRA			FLA	LRA	
A06	208/230-1-60	STD	NONE	—	—	40	60	38	158	42	60	40	160	
			324A	4.9/6.5	23.5/27.1	69/74	80/80	65/69	182/185	71/75	80/80	67/71	184/187	
			325A	6.5/8.7	31.4/36.3	79/85	80/90	74/80	189/194	81/87	90/100	76/82	191/196	
			327A	9.8/13.0	46.9/54.2	98/107	100/110	92/100	205/212	100/109	100/110	94/103	207/214	
			329A	13.1/17.4	62.8/72.5	118/130	125/150	110/121	221/231	120/132	125/150	112/124	223/233	
			331A	15.8/21.0	75.8/87.5	134/149	150/150	125/139	234/246	136/151	150/175	127/141	236/248	
		MED	NONE	—	—	42	60	40	161	44	60	43	163	
			324A	4.9/6.5	23.5/27.1	71/76	80/80	67/72	185/188	73/77	80/80	70/74	187/190	
			325A	6.5/8.7	31.4/36.3	81/87	90/100	76/82	192/197	83/89	90/100	79/84	194/199	
			327A	9.8/13.0	46.9/54.2	100/109	100/110	94/103	208/215	102/111	110/125	96/105	210/217	
			329A	13.1/17.4	62.8/72.5	120/132	125/150	113/124	224/234	122/134	125/150	115/126	226/236	
			331A	15.8/21.0	75.8/87.5	136/151	150/175	128/141	237/249	138/153	150/175	130/143	239/251	
		HIGH	NONE	—	—	44	60	43	164	46	60	45	166	
			324A	4.9/6.5	23.5/27.1	74/78	80/80	70/74	188/191	75/80	80/80	72/77	190/193	
			325A	6.5/8.7	31.4/36.3	83/90	90/100	79/85	195/200	85/91	100/100	82/87	197/202	
			327A	9.8/13.0	46.9/54.2	103/112	110/125	97/106	211/218	105/114	110/125	99/108	213/220	
			329A	13.1/17.4	62.8/72.5	123/135	125/150	115/127	227/237	125/137	125/150	118/129	229/239	
			331A	15.8/21.0	75.8/87.5	139/154	150/175	130/144	240/252	141/155	150/175	133/146	242/254	
		208/230-3-60	STD	NONE	—	—	29	40	28	124	31	45	31	126
				324A	4.9/6.5	13.6/15.6	46/49	50/60	44/46	138/140	48/51	60/60	46/49	140/142
				326A	7.9/10.5	21.9/25.3	57/61	60/70	54/58	146/149	58/63	60/70	56/60	148/151
				328A	12.0/16.0	33.4/38.5	71/77	80/80	67/73	157/163	73/79	80/80	69/75	159/165
				331A	15.8/21.0	43.8/50.5	84/92	90/100	79/86	168/175	86/94	90/100	81/89	170/177
				332A	18.4/24.5	51.1/58.9	93/103	100/110	87/96	175/183	95/105	100/110	89/98	177/185
	MED		NONE	—	—	31	45	31	127	33	45	33	129	
			324A	4.9/6.5	13.6/15.6	48/51	60/60	46/49	141/143	50/53	60/60	49/51	143/145	
			326A	7.9/10.5	21.9/25.3	59/63	60/70	56/60	149/152	60/65	60/70	58/62	151/154	
			328A	12.0/16.0	33.4/38.5	73/79	80/80	69/75	160/166	75/81	80/90	71/77	162/168	
			331A	15.8/21.0	43.8/50.5	86/94	90/100	81/89	171/178	88/96	90/100	83/91	173/180	
			332A	18.4/24.5	51.1/58.9	95/105	100/110	89/98	178/186	97/107	100/110	92/101	180/188	
	HIGH		NONE	—	—	28	40	28	123	30	45	30	125	
			324A	4.9/6.5	13.6/15.6	45/48	50/50	43/46	137/139	47/50	50/60	45/48	139/141	
			326A	7.9/10.5	21.9/25.3	56/60	60/60	53/57	145/148	58/62	60/70	55/59	147/150	
			328A	12.0/16.0	33.4/38.5	70/77	70/80	66/72	156/162	72/78	80/80	68/74	158/164	
			331A	15.8/21.0	43.8/50.5	83/92	90/100	78/86	167/174	85/93	90/100	80/88	169/176	
			332A	18.4/24.5	51.1/58.9	92/102	100/110	86/95	174/182	94/104	100/110	89/98	176/184	
	460-3-60		STD	NONE	—	—	13	20	12	56	14	20	13	57
				333A	6.0	7.2	22	25	20	63	23	25	21	64
				335A	11.5	13.8	30	30	28	70	31	35	29	71
				336A	14.0	16.8	34	35	31	73	35	35	32	74
				337A	21.5	25.9	45	45	42	82	46	50	43	83
				338A	24.0	28.9	49	50	45	85	50	50	46	86
		MED	NONE	—	—	13	20	12	57	14	20	13	58	
			333A	6.0	7.2	22	25	21	64	23	25	22	65	
			335A	11.5	13.8	30	30	28	71	31	35	29	72	
			336A	14.0	16.8	34	35	32	74	35	35	33	75	
			337A	21.5	25.9	45	50	42	83	46	50	43	84	
			338A	24.0	28.9	49	50	46	86	50	50	47	87	
HIGH		NONE	—	—	14	20	13	58	15	20	15	59		
		333A	6.0	7.2	23	25	22	65	24	25	23	66		
		335A	11.5	13.8	31	35	29	72	32	35	30	73		
		336A	14.0	16.8	35	35	33	75	36	40	34	76		
		337A	21.5	25.9	46	50	43	84	47	50	44	85		
		338A	24.0	28.9	50	50	47	87	51	60	48	88		

Electrical data (cont)



50FCQA06 MCA MOCP ELECTRICAL DATA (cont)

50FCQ UNIT SIZE	NOM. V-Ph-Hz	IFM TYPE	ELECTRIC HEATER			NO CONVENIENCE OUTLET or UNPOWERED CONVENIENCE OUTLET							
			CRHEATER ****00	NOM (kW)	FLA	NO POWER EXHAUST				w/ POWER EXHAUST (powered from unit)			
						MCA	FUSE OR HACR BRKR	DISCONNECT SIZE		MCA	FUSE OR HACR BRKR	DISCONNECT SIZE	
FLA	LRA	FLA	LRA										
A06 (cont)	575-3-60	STD	NONE	—	—	10	15	9	43	12	15	11	45
			340A	15.0	14.4	28	30	26	57	30	30	28	59
			341A	21.0	20.2	35	35	32	63	37	40	34	65
		MED	NONE	—	—	10	15	10	44	12	15	12	46
			340A	15.0	14.4	28	30	26	58	30	30	28	60
			341A	21.0	20.2	35	35	33	64	37	40	35	66
		HIGH	NONE	—	—	11	15	10	45	13	15	13	47
			340A	15.0	14.4	29	30	27	59	31	35	29	61
			341A	21.0	20.2	36	40	34	65	38	40	36	67



50FCQA06 MCA MOCP ELECTRICAL DATA (cont)

50FCQ UNIT SIZE	NOM. V-Ph-Hz	IFM TYPE	ELECTRIC HEATER			w/ POWERED CONVENIENCE OUTLET								
			CRHEATER ****00	NOM (kW)	FLA	NO POWER EXHAUST				w/ POWER EXHAUST (powered from unit)				
						MCA	FUSE OR HACR BRKR	DISCONNECT SIZE		MCA	FUSE OR HACR BRKR	DISCONNECT SIZE		
		FLA	LRA	FLA	LRA									
A06	208/230-1-60	STD	NONE	—	—	—	—	—	—	—	—	—	—	—
			324A	4.9/6.5	23.5/27.1	—	—	—	—	—	—	—	—	—
			325A	6.5/8.7	31.4/36.3	—	—	—	—	—	—	—	—	—
			327A	9.8/13.0	46.9/54.2	—	—	—	—	—	—	—	—	—
			329A	13.1/17.4	62.8/72.5	—	—	—	—	—	—	—	—	—
		331A	15.8/21.0	75.8/87.5	—	—	—	—	—	—	—	—	—	
		MED	NONE	—	—	—	—	—	—	—	—	—	—	—
			324A	4.9/6.5	23.5/27.1	—	—	—	—	—	—	—	—	—
			325A	6.5/8.7	31.4/36.3	—	—	—	—	—	—	—	—	—
			327A	9.8/13.0	46.9/54.2	—	—	—	—	—	—	—	—	—
			329A	13.1/17.4	62.8/72.5	—	—	—	—	—	—	—	—	—
		HIGH	NONE	—	—	—	—	—	—	—	—	—	—	—
			324A	4.9/6.5	23.5/27.1	—	—	—	—	—	—	—	—	—
			325A	6.5/8.7	31.4/36.3	—	—	—	—	—	—	—	—	—
			327A	9.8/13.0	46.9/54.2	—	—	—	—	—	—	—	—	—
	329A		13.1/17.4	62.8/72.5	—	—	—	—	—	—	—	—	—	
	208/230-3-60	STD	NONE	—	—	34	45	34	129	36	50	36	131	
			324A	4.9/6.5	13.6/15.6	51/53	60/60	50/52	143/145	53/55	60/60	52/54	145/147	
			326A	7.9/10.5	21.9/25.3	61/66	70/70	59/63	151/154	63/67	70/70	61/65	153/156	
			328A	12.0/16.0	33.4/38.5	76/82	80/90	72/78	162/168	78/84	80/90	75/80	164/170	
			331A	15.8/21.0	43.8/50.5	89/97	90/100	84/92	173/180	91/99	100/100	86/94	175/182	
		332A	18.4/24.5	51.1/58.9	98/108	100/110	93/102	180/188	100/109	100/110	95/104	182/190		
		MED	NONE	—	—	36	50	36	132	38	50	38	134	
			324A	4.9/6.5	13.6/15.6	53/55	60/60	52/54	146/148	55/57	60/60	54/56	148/150	
			326A	7.9/10.5	21.9/25.3	63/68	70/70	61/65	154/157	65/69	70/70	64/68	156/159	
			328A	12.0/16.0	33.4/38.5	78/84	80/90	75/81	165/171	80/86	80/90	77/83	167/173	
			331A	15.8/21.0	43.8/50.5	91/99	100/100	87/94	176/183	93/101	100/110	89/96	178/185	
		332A	18.4/24.5	51.1/58.9	100/110	100/110	95/104	183/191	102/111	110/125	97/106	185/193		
		HIGH	NONE	—	—	33	45	33	128	35	50	35	130	
			324A	4.9/6.5	13.6/15.6	50/53	60/60	49/51	142/144	52/55	60/60	51/53	144/146	
			326A	7.9/10.5	21.9/25.3	61/65	70/70	58/62	150/153	63/67	70/70	60/64	152/155	
	328A		12.0/16.0	33.4/38.5	75/81	80/90	72/77	161/167	77/83	80/90	74/80	163/169		
	331A		15.8/21.0	43.8/50.5	88/96	90/100	83/91	172/179	90/98	90/100	86/93	174/181		
	332A	18.4/24.5	51.1/58.9	97/107	100/110	92/101	179/187	99/109	100/110	94/103	181/189			
	460-3-60	STD	NONE	—	—	15	20	14	58	16	20	16	59	
			333A	6.0	7.2	24	25	23	65	25	30	24	66	
			335A	11.5	13.8	32	35	30	72	33	35	31	73	
			336A	14.0	16.8	36	40	34	75	37	40	35	76	
			337A	21.5	25.9	47	50	44	84	48	50	45	85	
		338A	24.0	28.9	51	60	48	87	52	60	49	88		
		MED	NONE	—	—	15	20	15	59	16	20	16	60	
			333A	6.0	7.2	24	25	23	66	25	30	24	67	
			335A	11.5	13.8	33	35	31	73	34	35	32	74	
			336A	14.0	16.8	36	40	34	76	37	40	35	77	
			337A	21.5	25.9	48	50	45	85	49	50	46	86	
		338A	24.0	28.9	51	60	48	88	52	60	49	89		
		HIGH	NONE	—	—	16	20	16	60	17	20	17	61	
			333A	6.0	7.2	25	30	24	67	26	30	25	68	
			335A	11.5	13.8	34	35	32	74	35	35	33	75	
	336A		14.0	16.8	37	40	35	77	38	40	36	78		
	337A		21.5	25.9	49	50	46	86	50	50	47	87		
	338A	24.0	28.9	52	60	49	89	53	60	50	90			

Electrical data (cont)



50FCQA06 MCA MOCAP ELECTRICAL DATA (cont)

50FCQ UNIT SIZE	NOM. V-Ph-Hz	IFM TYPE	ELECTRIC HEATER			w/ POWERED CONVENIENCE OUTLET							
			CRHEATER ****00	NOM (kW)	FLA	NO POWER EXHAUST				w/ POWER EXHAUST (powered from unit)			
						MCA	FUSE OR HACR BRKR	DISCONNECT SIZE		MCA	FUSE OR HACR BRKR	DISCONNECT SIZE	
FLA	LRA	FLA	LRA										
A06 (cont)	575-3-60	STD	NONE	—	—	11	15	11	45	13	15	13	47
			340A	15.0	14.4	29	30	27	59	31	35	30	61
			341A	21.0	20.2	37	40	34	65	39	40	36	67
		MED	NONE	—	—	12	15	12	46	14	15	14	48
			340A	15.0	14.4	30	30	28	60	32	35	30	62
			341A	21.0	20.2	37	40	35	66	39	40	37	68
		HIGH	NONE	—	—	13	15	12	47	14	20	14	49
			340A	15.0	14.4	31	35	29	61	32	35	31	63
			341A	21.0	20.2	38	40	36	67	40	40	38	69



50FCQM07 MCA MOCP ELECTRICAL DATA

50FCQ UNIT SIZE	NOM. V-Ph-Hz	IFM TYPE	ELECTRIC HEATER			NO CONVENIENCE OUTLET or UNPOWERED CONVENIENCE OUTLET							
			CRHEATER ****00	NOM (kW)	FLA	NO POWER EXHAUST				w/ POWER EXHAUST (powered from unit)			
						MCA	FUSE OR HACR BRKR	DISCONNECT SIZE		MCA	FUSE OR HACR BRKR	DISCONNECT SIZE	
								FLA	LRA			FLA	LRA
M07	208/230-3-60	STD	NONE	—	—	34	50	33	153	36	50	35	155
			324A	4.9/6.5	13.6/15.6	51/53	60/60	49/51	167/169	53/55	60/60	51/53	169/171
			326A	7.9/10.5	21.9/25.3	61/65	70/70	58/62	175/178	63/67	70/70	60/64	177/180
			328A	12.0/16.0	33.4/38.5	75/82	80/90	71/77	186/192	77/84	80/90	74/79	188/194
			331A	15.8/21.0	43.8/50.5	88/97	90/100	83/91	197/204	90/99	90/100	86/93	199/206
			332A	18.4/24.5	51.1/58.9	98/107	100/110	92/101	204/212	99/109	100/110	94/103	206/214
		MED	NONE	—	—	30	45	29	148	32	45	31	150
			324A	4.9/6.5	13.6/15.6	47/49	60/60	44/47	162/164	49/51	60/60	47/49	164/166
			326A	7.9/10.5	21.9/25.3	57/62	60/70	54/58	170/173	59/63	60/70	56/60	172/175
			328A	12.0/16.0	33.4/38.5	72/78	80/80	67/73	181/187	74/80	80/80	69/75	183/189
			331A	15.8/21.0	43.8/50.5	85/93	90/100	79/87	192/199	87/95	90/100	81/89	194/201
			332A	18.4/24.5	51.1/58.9	94/104	100/110	88/96	199/207	96/105	100/110	90/99	201/209
		HIGH	NONE	—	—	31	45	30	149	33	50	32	151
			324A	4.9/6.5	13.6/15.6	48/50	60/60	46/48	163/165	50/52	60/60	48/50	165/167
			326A	7.9/10.5	21.9/25.3	58/63	60/70	55/59	171/174	60/64	60/70	57/61	173/176
			328A	12.0/16.0	33.4/38.5	73/79	80/80	68/74	182/188	75/81	80/90	70/76	184/190
			331A	15.8/21.0	43.8/50.5	86/94	90/100	80/88	193/200	88/96	90/100	82/90	195/202
			332A	18.4/24.5	51.1/58.9	95/105	100/110	89/98	200/208	97/106	100/110	91/100	202/210
	460-3-60	STD	NONE	—	—	14	20	13	71	15	20	14	72
			333A	6.0	7.2	23	25	21	78	24	30	23	79
			335A	11.5	13.8	31	35	29	85	32	35	30	86
			336A	14.0	16.8	35	35	32	88	36	40	34	89
			337A	21.5	25.9	46	50	43	97	47	50	44	98
			338A	24.0	28.9	50	50	46	100	51	60	47	101
		MED	NONE	—	—	14	20	14	72	15	20	15	73
			333A	6.0	7.2	23	25	22	79	24	30	23	80
			335A	11.5	13.8	32	35	30	86	33	35	31	87
			336A	14.0	16.8	35	40	33	89	36	40	34	90
			337A	21.5	25.9	47	50	43	98	48	50	45	99
			338A	24.0	28.9	51	60	47	101	52	60	48	102
		HIGH	NONE	—	—	15	20	14	72	16	20	15	73
			333A	6.0	7.2	24	30	23	79	25	30	24	80
			335A	11.5	13.8	32	35	30	86	33	35	31	87
			336A	14.0	16.8	36	40	34	89	37	40	35	90
			337A	21.5	25.9	47	50	44	98	48	50	45	99
			338A	24.0	28.9	51	60	47	101	52	60	49	102
	575-3-60	STD	NONE	—	—	12	15	11	60	14	20	14	62
			340A	15.0	14.4	30	30	28	74	32	35	30	76
			341A	21.0	20.2	37	40	35	80	39	40	37	82
		MED	NONE	—	—	12	15	12	60	14	20	14	62
			340A	15.0	14.4	30	35	28	74	32	35	30	76
			341A	21.0	20.2	38	40	35	80	40	40	37	82
HIGH		NONE	—	—	13	15	12	61	15	20	14	63	
		340A	15.0	14.4	31	35	29	75	33	35	31	77	
		341A	21.0	20.2	38	40	35	81	40	40	38	83	

50FCQM07 MCA MOCPP ELECTRICAL DATA (cont)

50FCQ UNIT SIZE	NOM. V-Ph-Hz	IFM TYPE	ELECTRIC HEATER			w/ POWERED CONVENIENCE OUTLET							
			CRHEATER ****00	NOM (kW)	FLA	NO POWER EXHAUST				w/ POWER EXHAUST (powered from unit)			
						MCA	FUSE OR HACR BRKR	DISCONNECT SIZE		MCA	FUSE OR HACR BRKR	DISCONNECT SIZE	
								FLA	LRA			FLA	LRA
M07	208/230-3-60	STD	NONE	—	—	38	50	39	158	40	50	41	160
			324A	4.9/6.5	13.6/15.6	55/58	60/60	54/56	172/174	57/60	60/60	56/59	174/176
			326A	7.9/10.5	21.9/25.3	66/70	70/80	64/68	180/183	68/72	70/80	66/70	182/185
			328A	12.0/16.0	33.4/38.5	80/87	80/90	77/83	191/197	82/88	90/90	79/85	193/199
			331A	15.8/21.0	43.8/50.5	93/102	100/110	89/97	202/209	95/103	100/110	91/99	204/211
		332A	18.4/24.5	51.1/58.9	102/112	110/125	97/106	209/217	104/114	110/125	99/108	211/219	
		MED	NONE	—	—	35	50	34	153	37	50	36	155
			324A	4.9/6.5	13.6/15.6	52/54	60/60	50/52	167/169	54/56	60/60	52/54	169/171
			326A	7.9/10.5	21.9/25.3	62/66	70/70	59/63	175/178	64/68	70/70	62/66	177/180
			328A	12.0/16.0	33.4/38.5	77/83	80/90	73/79	186/192	78/85	80/90	75/81	188/194
			331A	15.8/21.0	43.8/50.5	90/98	90/100	85/92	197/204	91/100	100/100	87/95	199/206
		332A	18.4/24.5	51.1/58.9	99/108	100/110	93/102	204/212	101/110	110/110	95/104	206/214	
		HIGH	NONE	—	—	36	50	35	154	38	50	38	156
			324A	4.9/6.5	13.6/15.6	53/55	60/60	51/53	168/170	55/57	60/60	53/56	170/172
			326A	7.9/10.5	21.9/25.3	63/67	70/70	61/65	176/179	65/69	70/80	63/67	178/181
	328A		12.0/16.0	33.4/38.5	78/84	80/90	74/80	187/193	79/86	80/90	76/82	189/195	
	331A		15.8/21.0	43.8/50.5	91/99	100/100	86/93	198/205	92/101	100/110	88/96	200/207	
	332A	18.4/24.5	51.1/58.9	100/109	100/110	94/103	205/213	102/111	110/125	96/105	207/215		
	460-3-60	STD	NONE	—	—	16	20	16	73	17	25	17	74
			333A	6.0	7.2	25	30	24	80	26	30	25	81
			335A	11.5	13.8	33	35	32	87	34	35	33	88
			336A	14.0	16.8	37	40	35	90	38	40	36	91
			337A	21.5	25.9	49	50	45	99	50	50	47	100
		338A	24.0	28.9	52	60	49	102	53	60	50	103	
		MED	NONE	—	—	17	20	16	74	18	25	17	75
			333A	6.0	7.2	26	30	24	81	27	30	26	82
			335A	11.5	13.8	34	35	32	88	35	35	33	89
			336A	14.0	16.8	38	40	36	91	39	40	37	92
			337A	21.5	25.9	49	50	46	100	50	50	47	101
		338A	24.0	28.9	53	60	49	103	54	60	51	104	
		HIGH	NONE	—	—	17	25	17	74	18	25	18	75
			333A	6.0	7.2	26	30	25	81	27	30	26	82
			335A	11.5	13.8	34	35	33	88	35	40	34	89
	336A		14.0	16.8	38	40	36	91	39	40	37	92	
	337A		21.5	25.9	50	50	47	100	51	60	48	101	
	338A	24.0	28.9	53	60	50	103	54	60	51	104		
575-3-60	STD	NONE	—	—	14	20	13	62	16	20	16	64	
		340A	15.0	14.4	32	35	30	76	34	35	32	78	
		341A	21.0	20.2	39	40	37	82	41	45	39	84	
	MED	NONE	—	—	14	20	14	62	16	20	16	64	
		340A	15.0	14.4	32	35	30	76	34	35	32	78	
		341A	21.0	20.2	39	40	37	82	41	45	39	84	
	HIGH	NONE	—	—	15	20	14	63	16	20	16	65	
		340A	15.0	14.4	33	35	31	77	34	35	33	79	
		341A	21.0	20.2	40	40	37	83	42	45	40	85	



50FCQA04 ELECTRIC HEAT DATA — WITHOUT NON-FUSED DISCONNECT

50FCQ UNIT SIZE	NOM. V-Ph-Hz	IFM TYPE	ELECTRIC HEATER PART NUMBER	NOM (kW)	APPLICATION (kW)	APPLICATION OUTPUT (MBH)	SINGLE POINT OR JUNCTION PART NUMBER CRSINGLEXXXA00			
							NO C.O. OR UNPOWERED C.O.		w/PWRD C.O.	
							NO P.E.	w/P.E. (pwrd fr/unit)	NO P.E	w/P.E. (pwrd fr/unit)
A04	208/230-1-60	STD	CRHEATER323A00	4.4	3.3/4.0	11.3/13.8	—	—	—	—
			CRHEATER324A00	6.5	4.9/6.0	16.7/20.4	037	037	—	—
			CRHEATER325A00	8.7	6.5/8.0	22.3/27.3	040	040	—	—
			CRHEATER326A00	10.5	7.9/9.6	26.9/32.9	040	040	—	—
			CRHEATER327A00	13.0	9.8/11.9	33.3/40.7	041	041	—	—
		MED	CRHEATER323A00	4.4	3.3/4.0	11.3/13.8	—	037	—	—
			CRHEATER324A00	6.5	4.9/6.0	16.7/20.4	037	040	—	—
			CRHEATER325A00	8.7	6.5/8.0	22.3/27.3	040	040	—	—
			CRHEATER326A00	10.5	7.9/9.6	26.9/32.9	040	040	—	—
			CRHEATER327A00	13.0	9.8/11.9	33.3/40.7	041	041	—	—
		HIGH	CRHEATER323A00	4.4	3.3/4.0	11.3/13.8	037	037	—	—
			CRHEATER324A00	6.5	4.9/6.0	16.7/20.4	040	040	—	—
			CRHEATER325A00	8.7	6.5/8.0	22.3/27.3	040	040	—	—
			CRHEATER326A00	10.5	7.9/9.6	26.9/32.9	040	040	—	—
			CRHEATER327A00	13.0	9.8/11.9	33.3/40.7	041	041	—	—
	208/230-3-60	STD	CRHEATER323A00	4.4	3.3/4.0	11.3/13.8	—	—	—	—
			CRHEATER324A00	6.5	4.9/6.0	16.7/20.4	—	—	—	—
			CRHEATER325A00	8.7	6.5/8.0	22.3/27.3	—	—	—	037
			CRHEATER326A00	10.5	7.9/9.6	26.9/32.9	—	037	037	037
			CRHEATER328A00	16.0	12.0/14.7	41.0/50.1	038	038	038	038
		MED	CRHEATER323A00	4.4	3.3/4.0	11.3/13.8	—	—	—	—
			CRHEATER324A00	6.5	4.9/6.0	16.7/20.4	—	—	—	—
			CRHEATER325A00	8.7	6.5/8.0	22.3/27.3	—	—	037	037
			CRHEATER326A00	10.5	7.9/9.6	26.9/32.9	037	037	037	037
			CRHEATER328A00	16.0	12.0/14.7	41.0/50.1	038	038	038	038
		HIGH	CRHEATER323A00	4.4	3.3/4.0	11.3/13.8	—	—	—	—
			CRHEATER324A00	6.5	4.9/6.0	16.7/20.4	—	—	—	—
			CRHEATER325A00	8.7	6.5/8.0	22.3/27.3	—	—	037	037
			CRHEATER326A00	10.5	7.9/9.6	26.9/32.9	037	037	037	038
			CRHEATER328A00	16.0	12.0/14.7	41.0/50.1	038	038	038	038
	460-3-60	STD	CRHEATER333A00	6.0	5.5	18.8	—	—	—	—
			CRHEATER334A00	8.8	8.1	27.6	—	—	—	—
			CRHEATER335A00	11.5	10.6	36.0	—	—	—	—
			CRHEATER336A00	14.0	12.9	43.9	—	—	—	—
		MED	CRHEATER333A00	6.0	5.5	18.8	—	—	—	—
			CRHEATER334A00	8.8	8.1	27.6	—	—	—	—
CRHEATER335A00			11.5	10.6	36.0	—	—	—	—	
CRHEATER336A00			14.0	12.9	43.9	—	—	—	—	
HIGH		CRHEATER333A00	6.0	5.5	18.8	—	—	—	—	
		CRHEATER334A00	8.8	8.1	27.6	—	—	—	—	
		CRHEATER335A00	11.5	10.6	36.0	—	—	—	—	
		CRHEATER336A00	14.0	12.9	43.9	—	—	—	—	
575-3-60	STD	CRHEATER339A00	10.0	9.2	31.3	—	—	—	—	
		CRHEATER340A00	15.0	13.8	47.0	—	—	—	—	
	MED	CRHEATER339A00	10.0	9.2	31.3	—	—	—	—	
		CRHEATER340A00	15.0	13.8	47.0	—	—	—	—	
	HIGH	CRHEATER339A00	10.0	9.2	31.3	—	—	—	—	
		CRHEATER340A00	15.0	13.8	47.0	—	—	—	—	

50FCQA04 ELECTRIC HEAT DATA — WITH NON-FUSED DISCONNECT

50FCQ UNIT SIZE	NOM. V-Ph-Hz	IFM TYPE	ELECTRIC HEATER PART NUMBER	NOM (kW)	APPLICATION (kW)	APPLICATION OUTPUT (MBH)	SINGLE POINT OR JUNCTION PART NUMBER CRSINGLEXXXA00			
							NO C.O. OR UNPOWERED C.O.		w/PWRD C.O.	
							NO P.E.	w/P.E. (pwrd fr/unit)	NO P.E	w/P.E. (pwrd fr/unit)
A04	208/230-1-60	STD	CRHEATER323A00	4.4	3.3/4.0	11.3/13.8	037	037	—	—
			CRHEATER324A00	6.5	4.9/6.0	16.7/20.4	037	037	—	—
			CRHEATER325A00	8.7	6.5/8.0	22.3/27.3	040	040	—	—
			CRHEATER326A00	10.5	7.9/9.6	26.9/32.9	040	040	—	—
			CRHEATER327A00	13.0	9.8/11.9	33.3/40.7	041	041	—	—
		MED	CRHEATER323A00	4.4	3.3/4.0	11.3/13.8	037	037	—	—
			CRHEATER324A00	6.5	4.9/6.0	16.7/20.4	037	040	—	—
			CRHEATER325A00	8.7	6.5/8.0	22.3/27.3	040	040	—	—
			CRHEATER326A00	10.5	7.9/9.6	26.9/32.9	040	040	—	—
			CRHEATER327A00	13.0	9.8/11.9	33.3/40.7	041	041	—	—
		HIGH	CRHEATER323A00	4.4	3.3/4.0	11.3/13.8	037	037	—	—
			CRHEATER324A00	6.5	4.9/6.0	16.7/20.4	040	040	—	—
	CRHEATER325A00		8.7	6.5/8.0	22.3/27.3	040	040	—	—	
	CRHEATER326A00		10.5	7.9/9.6	26.9/32.9	040	040	—	—	
	208/230-3-60	STD	CRHEATER323A00	4.4	3.3/4.0	11.3/13.8	037	037	037	037
			CRHEATER324A00	6.5	4.9/6.0	16.7/20.4	037	037	037	037
			CRHEATER325A00	8.7	6.5/8.0	22.3/27.3	037	037	037	037
			CRHEATER326A00	10.5	7.9/9.6	26.9/32.9	037	037	037	037
			CRHEATER328A00	16.0	12.0/14.7	41.0/50.1	038	038	038	038
		MED	CRHEATER323A00	4.4	3.3/4.0	11.3/13.8	037	037	037	037
			CRHEATER324A00	6.5	4.9/6.0	16.7/20.4	037	037	037	037
			CRHEATER325A00	8.7	6.5/8.0	22.3/27.3	037	037	037	037
			CRHEATER326A00	10.5	7.9/9.6	26.9/32.9	037	037	037	037
		HIGH	CRHEATER328A00	16.0	12.0/14.7	41.0/50.1	038	038	038	038
CRHEATER323A00			4.4	3.3/4.0	11.3/13.8	037	037	037	037	
CRHEATER324A00			6.5	4.9/6.0	16.7/20.4	037	037	037	037	
CRHEATER325A00	8.7		6.5/8.0	22.3/27.3	037	037	037	037		
CRHEATER326A00	10.5		7.9/9.6	26.9/32.9	037	037	037	038		
460-3-60	STD	CRHEATER333A00	6.0	5.5	18.8	—	—	—	—	
		CRHEATER334A00	8.8	8.1	27.6	—	—	—	—	
		CRHEATER335A00	11.5	10.6	36.0	—	—	—	—	
		CRHEATER336A00	14.0	12.9	43.9	—	—	—	—	
	MED	CRHEATER333A00	6.0	5.5	18.8	—	—	—	—	
		CRHEATER334A00	8.8	8.1	27.6	—	—	—	—	
		CRHEATER335A00	11.5	10.6	36.0	—	—	—	—	
		CRHEATER336A00	14.0	12.9	43.9	—	—	—	—	
	HIGH	CRHEATER333A00	6.0	5.5	18.8	—	—	—	—	
		CRHEATER334A00	8.8	8.1	27.6	—	—	—	—	
		CRHEATER335A00	11.5	10.6	36.0	—	—	—	—	
		CRHEATER336A00	14.0	12.9	43.9	—	—	—	—	
575-3-60	STD	CRHEATER339A00	10.0	9.2	31.3	—	—	—	—	
		CRHEATER340A00	15.0	13.8	47.0	—	—	—	—	
	MED	CRHEATER339A00	10.0	9.2	31.3	—	—	—	—	
		CRHEATER340A00	15.0	13.8	47.0	—	—	—	—	
	HIGH	CRHEATER339A00	10.0	9.2	31.3	—	—	—	—	
		CRHEATER340A00	15.0	13.8	47.0	—	—	—	—	



50FCQA05 ELECTRIC HEAT DATA — WITHOUT NON-FUSED DISCONNECT

50FCQ UNIT SIZE	NOM. V-Ph-Hz	IFM TYPE	ELECTRIC HEATER PART NUMBER	NOM (kW)	APPLICATION (kW)	APPLICATION OUTPUT (MBH)	SINGLE POINT OR JUNCTION PART NUMBER CRSINGLEXXXXA00					
							NO C.O. OR UNPOWERED C.O.		w/PWRD C.O.			
							NO P.E.	w/P.E. (pwrd fr/unit)	NO P.E	w/P.E. (pwrd fr/unit)		
208/230-1-60		STD	CRHEATER323A00	4.4	3.3/4.0	11.3/13.8	037	037	—	—		
			CRHEATER325A00	8.7	6.5/8.0	22.3/27.3	040	040	—	—		
			CRHEATER327A00	13.0	9.8/11.9	33.3/40.7	041	041	—	—		
			CRHEATER329A00	17.4	13.1/16.0	44.6/54.5	041	041	—	—		
			CRHEATER330A00	19.2	14.4/17.6	49.2/60.2	041	041	—	—		
			CRHEATER331A00	21.0	15.8/19.3	53.8/65.8	041	041	—	—		
		MED	CRHEATER323A00	4.4	3.3/4.0	11.3/13.8	037	037	—	—		
			CRHEATER325A00	8.7	6.5/8.0	22.3/27.3	040	040	—	—		
			CRHEATER327A00	13.0	9.8/11.9	33.3/40.7	041	041	—	—		
			CRHEATER329A00	17.4	13.1/16.0	44.6/54.5	041	041	—	—		
			CRHEATER330A00	19.2	14.4/17.6	49.2/60.2	041	041	—	—		
			CRHEATER331A00	21.0	15.8/19.3	53.8/65.8	041	041	—	—		
		HIGH	CRHEATER323A00	4.4	3.3/4.0	11.3/13.8	037	040	—	—		
			CRHEATER325A00	8.7	6.5/8.0	22.3/27.3	040	040	—	—		
			CRHEATER327A00	13.0	9.8/11.9	33.3/40.7	041	041	—	—		
			CRHEATER329A00	17.4	13.1/16.0	44.6/54.5	041	041	—	—		
			CRHEATER330A00	19.2	14.4/17.6	49.2/60.2	041	041	—	—		
			CRHEATER331A00	21.0	15.8/19.3	53.8/65.8	041	041	—	—		
		A05 208/230-3-60		STD	CRHEATER323A00	4.4	3.3/4.0	11.3/13.8	—	—	—	—
					CRHEATER324A00	6.5	4.9/6.0	16.7/20.4	—	—	—	—
					CRHEATER325A00	8.7	6.5/8.0	22.3/27.3	—	037	037	037
					CRHEATER328A00	16.0	12.0/14.7	41.0/50.1	038	038	038	038
					CRHEATER330A00	19.2	14.4/17.6	49.2/60.2	039	039	039	039
					CRHEATER331A00	21.0	15.8/19.3	53.8/65.8	039	039	039	039
MED	CRHEATER323A00			4.4	3.3/4.0	11.3/13.8	—	—	—	—		
	CRHEATER324A00			6.5	4.9/6.0	16.7/20.4	—	—	—	037		
	CRHEATER325A00			8.7	6.5/8.0	22.3/27.3	037	037	037	037		
	CRHEATER328A00			16.0	12.0/14.7	41.0/50.1	038	038	038	038		
	CRHEATER330A00			19.2	14.4/17.6	49.2/60.2	039	039	039	039		
	CRHEATER331A00			21.0	15.8/19.3	53.8/65.8	039	039	039	039		
HIGH	CRHEATER323A00			4.4	3.3/4.0	11.3/13.8	—	—	—	—		
	CRHEATER324A00			6.5	4.9/6.0	16.7/20.4	—	—	—	—		
	CRHEATER325A00			8.7	6.5/8.0	22.3/27.3	—	037	037	037		
	CRHEATER328A00			16.0	12.0/14.7	41.0/50.1	038	038	038	038		
	CRHEATER330A00			19.2	14.4/17.6	49.2/60.2	039	039	039	039		
	CRHEATER331A00			21.0	15.8/19.3	53.8/65.8	039	039	039	039		
460-3-60				STD	CRHEATER333A00	6.0	5.5	18.8	—	—	—	—
					CRHEATER335A00	11.5	10.6	36.0	—	—	—	—
					CRHEATER336A00	14.0	12.9	43.9	—	—	—	—
					CRHEATER337A00	21.5	19.7	67.4	037	037	037	037
				MED	CRHEATER333A00	6.0	5.5	18.8	—	—	—	—
					CRHEATER335A00	11.5	10.6	36.0	—	—	—	—
		CRHEATER336A00	14.0		12.9	43.9	—	—	—	—		
		CRHEATER337A00	21.5		19.7	67.4	037	037	037	037		
		HIGH	CRHEATER333A00	6.0	5.5	18.8	—	—	—	—		
			CRHEATER335A00	11.5	10.6	36.0	—	—	—	—		
			CRHEATER336A00	14.0	12.9	43.9	—	—	—	—		
			CRHEATER337A00	21.5	19.7	67.4	037	037	037	037		
575-3-60		STD	CRHEATER339A00	10.0	9.2	31.3	—	—	—	—		
			CRHEATER340A00	15.0	13.8	47.0	—	—	—	—		
		MED	CRHEATER339A00	10.0	9.2	31.3	—	—	—	—		
			CRHEATER340A00	15.0	13.8	47.0	—	—	—	—		
		HIGH	CRHEATER339A00	10.0	9.2	31.3	—	—	—	—		
			CRHEATER340A00	15.0	13.8	47.0	—	—	—	—		

50FCQA05 ELECTRIC HEAT DATA — WITH NON-FUSED DISCONNECT

50FCQ UNIT SIZE	NOM. V-Ph-Hz	IFM TYPE	ELECTRIC HEATER PART NUMBER	NOM (kW)	APPLICATION (kW)	APPLICATION OUTPUT (MBH)	SINGLE POINT OR JUNCTION PART NUMBER CRSINGLEXXXA00			
							NO C.O. OR UNPOWERED C.O.		w/PWRD C.O.	
							NO P.E.	w/P.E. (pwrd fr/unit)	NO P.E	w/P.E. (pwrd fr/unit)
A05	208/230-1-60	STD	CRHEATER323A00	4.4	3.3/4.0	11.3/13.8	037	037	—	—
			CRHEATER325A00	8.7	6.5/8.0	22.3/27.3	040	040	—	—
			CRHEATER327A00	13.0	9.8/11.9	33.3/40.7	041	041	—	—
			CRHEATER329A00	17.4	13.1/16.0	44.6/54.5	041	041	—	—
			CRHEATER330A00	19.2	14.4/17.6	49.2/60.2	041	041	—	—
		CRHEATER331A00	21.0	15.8/19.3	53.8/65.8	041	041	—	—	
		MED	CRHEATER323A00	4.4	3.3/4.0	11.3/13.8	037	037	—	—
			CRHEATER325A00	8.7	6.5/8.0	22.3/27.3	040	040	—	—
			CRHEATER327A00	13.0	9.8/11.9	33.3/40.7	041	041	—	—
			CRHEATER329A00	17.4	13.1/16.0	44.6/54.5	041	041	—	—
			CRHEATER330A00	19.2	14.4/17.6	49.2/60.2	041	041	—	—
		CRHEATER331A00	21.0	15.8/19.3	53.8/65.8	041	041	—	—	
	HIGH	CRHEATER323A00	4.4	3.3/4.0	11.3/13.8	037	040	—	—	
		CRHEATER325A00	8.7	6.5/8.0	22.3/27.3	040	040	—	—	
		CRHEATER327A00	13.0	9.8/11.9	33.3/40.7	041	041	—	—	
		CRHEATER329A00	17.4	13.1/16.0	44.6/54.5	041	041	—	—	
		CRHEATER330A00	19.2	14.4/17.6	49.2/60.2	041	041	—	—	
	CRHEATER331A00	21.0	15.8/19.3	53.8/65.8	041	041	—	—		
	208/230-3-60	STD	CRHEATER323A00	4.4	3.3/4.0	11.3/13.8	037	037	037	037
			CRHEATER324A00	6.5	4.9/6.0	16.7/20.4	037	037	037	037
			CRHEATER325A00	8.7	6.5/8.0	22.3/27.3	037	037	037	037
			CRHEATER328A00	16.0	12.0/14.7	41.0/50.1	038	038	038	038
			CRHEATER330A00	19.2	14.4/17.6	49.2/60.2	039	039	039	039
		CRHEATER331A00	21.0	15.8/19.3	53.8/65.8	039	039	039	039	
MED		CRHEATER323A00	4.4	3.3/4.0	11.3/13.8	037	037	037	037	
		CRHEATER324A00	6.5	4.9/6.0	16.7/20.4	037	037	037	037	
		CRHEATER325A00	8.7	6.5/8.0	22.3/27.3	037	037	037	037	
		CRHEATER328A00	16.0	12.0/14.7	41.0/50.1	038	038	038	038	
		CRHEATER330A00	19.2	14.4/17.6	49.2/60.2	039	039	039	039	
CRHEATER331A00		21.0	15.8/19.3	53.8/65.8	039	039	039	039		
HIGH	CRHEATER323A00	4.4	3.3/4.0	11.3/13.8	037	037	037	037		
	CRHEATER324A00	6.5	4.9/6.0	16.7/20.4	037	037	037	037		
	CRHEATER325A00	8.7	6.5/8.0	22.3/27.3	037	037	037	037		
	CRHEATER328A00	16.0	12.0/14.7	41.0/50.1	038	038	038	038		
	CRHEATER330A00	19.2	14.4/17.6	49.2/60.2	039	039	039	039		
CRHEATER331A00	21.0	15.8/19.3	53.8/65.8	039	039	039	039			
460-3-60	STD	CRHEATER333A00	6.0	5.5	18.8	—	—	—	—	
		CRHEATER335A00	11.5	10.6	36.0	—	—	—	—	
		CRHEATER336A00	14.0	12.9	43.9	—	—	—	—	
		CRHEATER337A00	21.5	19.7	67.4	037	037	037	037	
	MED	CRHEATER333A00	6.0	5.5	18.8	—	—	—	—	
		CRHEATER335A00	11.5	10.6	36.0	—	—	—	—	
		CRHEATER336A00	14.0	12.9	43.9	—	—	—	—	
		CRHEATER337A00	21.5	19.7	67.4	037	037	037	037	
	HIGH	CRHEATER333A00	6.0	5.5	18.8	—	—	—	—	
		CRHEATER335A00	11.5	10.6	36.0	—	—	—	—	
		CRHEATER336A00	14.0	12.9	43.9	—	—	—	—	
		CRHEATER337A00	21.5	19.7	67.4	037	037	037	037	
575-3-60	STD	CRHEATER339A00	10.0	9.2	31.3	—	—	—	—	
		CRHEATER340A00	15.0	13.8	47.0	—	—	—	—	
	MED	CRHEATER339A00	10.0	9.2	31.3	—	—	—	—	
		CRHEATER340A00	15.0	13.8	47.0	—	—	—	—	
	HIGH	CRHEATER339A00	10.0	9.2	31.3	—	—	—	—	
		CRHEATER340A00	15.0	13.8	47.0	—	—	—	—	



50FCQA06 ELECTRIC HEAT DATA — WITHOUT NON-FUSED DISCONNECT

50FCQ UNIT SIZE	NOM. V-Ph-Hz	IFM TYPE	ELECTRIC HEATER PART NUMBER	NOM (kW)	APPLICATION (kW)	APPLICATION OUTPUT (MBH)	SINGLE POINT OR JUNCTION PART NUMBER CRSINGLEXXA00			
							NO C.O. OR UNPOWERED C.O.		w/PWRD C.O.	
							NO P.E.	w/P.E. (pwrd fr/unit)	NO P.E	w/P.E. (pwrd fr/unit)
A06	208/230-1-60	STD	CRHEATER324A00	6.5	4.9/6.0	16.7/20.4	040	040	—	—
			CRHEATER325A00	8.7	6.5/8.0	22.3/27.3	040	040	—	—
			CRHEATER327A00	13.0	9.8/11.9	33.3/40.7	041	041	—	—
			CRHEATER329A00	17.4	13.1/16.0	44.6/54.5	041	041	—	—
			CRHEATER331A00	21.0	15.8/19.3	53.8/65.8	041	041	—	—
		MED	CRHEATER324A00	6.5	4.9/6.0	16.7/20.4	040	040	—	—
			CRHEATER325A00	8.7	6.5/8.0	22.3/27.3	040	040	—	—
			CRHEATER327A00	13.0	9.8/11.9	33.3/40.7	041	041	—	—
			CRHEATER329A00	17.4	13.1/16.0	44.6/54.5	041	041	—	—
			CRHEATER331A00	21.0	15.8/19.3	53.8/65.8	041	041	—	—
		HIGH	CRHEATER324A00	6.5	4.9/6.0	16.7/20.4	040	040	—	—
			CRHEATER325A00	8.7	6.5/8.0	22.3/27.3	040	040	—	—
			CRHEATER327A00	13.0	9.8/11.9	33.3/40.7	041	041	—	—
			CRHEATER329A00	17.4	13.1/16.0	44.6/54.5	041	041	—	—
			CRHEATER331A00	21.0	15.8/19.3	53.8/65.8	041	041	—	—
	208/230-3-60	STD	CRHEATER324A00	6.5	4.9/6.0	16.7/20.4	—	037	037	037
			CRHEATER326A00	10.5	7.9/9.6	26.9/32.9	038	038	038	038
			CRHEATER328A00	16.0	12.0/14.7	41.0/50.1	038	038	038	038
			CRHEATER331A00	21.0	15.8/19.3	53.8/65.8	039	039	039	039
			CRHEATER332A00	24.5	18.4/22.5	62.8/76.8	039	039	039	039
		MED	CRHEATER324A00	6.5	4.9/6.0	16.7/20.4	—	037	037	037
			CRHEATER326A00	10.5	7.9/9.6	26.9/32.9	038	038	038	038
			CRHEATER328A00	16.0	12.0/14.7	41.0/50.1	038	038	038	038
			CRHEATER331A00	21.0	15.8/19.3	53.8/65.8	039	039	039	039
		HIGH	CRHEATER324A00	6.5	4.9/6.0	16.7/20.4	—	—	037	037
			CRHEATER326A00	10.5	7.9/9.6	26.9/32.9	037	038	038	038
			CRHEATER328A00	16.0	12.0/14.7	41.0/50.1	038	038	038	038
			CRHEATER331A00	21.0	15.8/19.3	53.8/65.8	039	039	039	039
460-3-60	STD	CRHEATER333A00	6.0	5.5	18.8	—	—	—	—	
		CRHEATER335A00	11.5	10.6	36.0	—	—	—	—	
		CRHEATER336A00	14.0	12.9	43.9	—	—	—	—	
		CRHEATER337A00	21.5	19.7	67.4	037	037	037	037	
		CRHEATER338A00	24.0	22.0	75.2	037	037	037	037	
	MED	CRHEATER333A00	6.0	5.5	18.8	—	—	—	—	
		CRHEATER335A00	11.5	10.6	36.0	—	—	—	—	
		CRHEATER336A00	14.0	12.9	43.9	—	—	—	—	
		CRHEATER337A00	21.5	19.7	67.4	037	037	037	037	
		CRHEATER338A00	24.0	22.0	75.2	037	037	037	037	
	HIGH	CRHEATER333A00	6.0	5.5	18.8	—	—	—	—	
		CRHEATER335A00	11.5	10.6	36.0	—	—	—	—	
		CRHEATER336A00	14.0	12.9	43.9	—	—	—	—	
		CRHEATER337A00	21.5	19.7	67.4	037	037	037	037	
		CRHEATER338A00	24.0	22.0	75.2	037	037	037	037	
575-3-60	STD	CRHEATER340A00	15.0	13.8	47.0	—	—	—	—	
		CRHEATER341A00	21.0	19.3	65.8	037	037	037	037	
	MED	CRHEATER340A00	15.0	13.8	47.0	—	—	—	—	
		CRHEATER341A00	21.0	19.3	65.8	037	037	037	037	
	HIGH	CRHEATER340A00	15.0	13.8	47.0	—	—	—	—	
		CRHEATER341A00	21.0	19.3	65.8	037	037	037	037	

50FCQA06 ELECTRIC HEAT DATA — WITH NON-FUSED DISCONNECT

50FCQ UNIT SIZE	NOM. V-Ph-Hz	IFM TYPE	ELECTRIC HEATER PART NUMBER	NOM (kW)	APPLICATION (kW)	APPLICATION OUTPUT (MBH)	SINGLE POINT OR JUNCTION PART NUMBER CRSINGLEXXXA00			
							NO C.O. OR UNPOWERED C.O.		w/PWRD C.O.	
							NO P.E.	w/P.E. (pwrd fr/unit)	NO P.E.	w/P.E. (pwrd fr/unit)
A06	208/230-1-60	STD	CRHEATER324A00	6.5	4.9/6.0	16.7/20.4	040	040	—	—
			CRHEATER325A00	8.7	6.5/8.0	22.3/27.3	040	040	—	—
			CRHEATER327A00	13.0	9.8/11.9	33.3/40.7	041	041	—	—
			CRHEATER329A00	17.4	13.1/16.0	44.6/54.5	041	041	—	—
			CRHEATER331A00	21.0	15.8/19.3	53.8/65.8	041	041	—	—
		MED	CRHEATER324A00	6.5	4.9/6.0	16.7/20.4	040	040	—	—
			CRHEATER325A00	8.7	6.5/8.0	22.3/27.3	040	040	—	—
			CRHEATER327A00	13.0	9.8/11.9	33.3/40.7	041	041	—	—
			CRHEATER329A00	17.4	13.1/16.0	44.6/54.5	041	041	—	—
			CRHEATER331A00	21.0	15.8/19.3	53.8/65.8	041	041	—	—
		HIGH	CRHEATER324A00	6.5	4.9/6.0	16.7/20.4	040	040	—	—
			CRHEATER325A00	8.7	6.5/8.0	22.3/27.3	040	040	—	—
	CRHEATER327A00		13.0	9.8/11.9	33.3/40.7	041	041	—	—	
	CRHEATER329A00		17.4	13.1/16.0	44.6/54.5	041	041	—	—	
	208/230-3-60	STD	CRHEATER324A00	6.5	4.9/6.0	16.7/20.4	037	037	037	037
			CRHEATER326A00	10.5	7.9/9.6	26.9/32.9	038	038	038	038
			CRHEATER328A00	16.0	12.0/14.7	41.0/50.1	038	038	038	038
			CRHEATER331A00	21.0	15.8/19.3	53.8/65.8	039	039	039	039
			CRHEATER332A00	24.5	18.4/22.5	62.8/76.8	039	039	039	039
		MED	CRHEATER324A00	6.5	4.9/6.0	16.7/20.4	037	037	037	037
			CRHEATER326A00	10.5	7.9/9.6	26.9/32.9	038	038	038	038
			CRHEATER328A00	16.0	12.0/14.7	41.0/50.1	038	038	038	038
			CRHEATER331A00	21.0	15.8/19.3	53.8/65.8	039	039	039	039
		HIGH	CRHEATER332A00	24.5	18.4/22.5	62.8/76.8	039	039	039	039
CRHEATER324A00			6.5	4.9/6.0	16.7/20.4	037	037	037	037	
CRHEATER326A00			10.5	7.9/9.6	26.9/32.9	037	038	038	038	
CRHEATER328A00	16.0		12.0/14.7	41.0/50.1	038	038	038	038		
CRHEATER331A00	21.0		15.8/19.3	53.8/65.8	039	039	039	039		
460-3-60	STD	CRHEATER333A00	6.0	5.5	18.8	—	—	—	—	
		CRHEATER335A00	11.5	10.6	36.0	—	—	—	—	
		CRHEATER336A00	14.0	12.9	43.9	—	—	—	—	
		CRHEATER337A00	21.5	19.7	67.4	037	037	037	037	
		CRHEATER338A00	24.0	22.0	75.2	037	037	037	037	
	MED	CRHEATER333A00	6.0	5.5	18.8	—	—	—	—	
		CRHEATER335A00	11.5	10.6	36.0	—	—	—	—	
		CRHEATER336A00	14.0	12.9	43.9	—	—	—	—	
		CRHEATER337A00	21.5	19.7	67.4	037	037	037	037	
		CRHEATER338A00	24.0	22.0	75.2	037	037	037	037	
	HIGH	CRHEATER333A00	6.0	5.5	18.8	—	—	—	—	
		CRHEATER335A00	11.5	10.6	36.0	—	—	—	—	
CRHEATER336A00		14.0	12.9	43.9	—	—	—	—		
CRHEATER337A00		21.5	19.7	67.4	037	037	037	037		
575-3-60	STD	CRHEATER340A00	15.0	13.8	47.0	—	—	—	—	
		CRHEATER341A00	21.0	19.3	65.8	037	037	037	037	
	MED	CRHEATER340A00	15.0	13.8	47.0	—	—	—	—	
		CRHEATER341A00	21.0	19.3	65.8	037	037	037	037	
	HIGH	CRHEATER340A00	15.0	13.8	47.0	—	—	—	—	
		CRHEATER341A00	21.0	19.3	65.8	037	037	037	037	



50FCQM07 ELECTRIC HEAT DATA — WITHOUT NON-FUSED DISCONNECT

50FCQ UNIT SIZE	NOM. V-Ph-Hz	IFM TYPE	ELECTRIC HEATER PART NUMBER	NOM (kW)	APPLICATION (kW)	APPLICATION OUTPUT (MBH)	SINGLE POINT OR JUNCTION PART NUMBER CRSINGLEXXXA00			
							NO C.O. OR UNPOWERED C.O.		w/PWRD C.O.	
							NO P.E.	w/P.E. (pwrd fr/unit)	NO P.E	w/P.E. (pwrd fr/unit)
M07	208/230-3-60	STD	CRHEATER324A00	6.5	4.9/6.0	16.7/20.4	037	037	037	037
			CRHEATER326A00	10.5	7.9/9.6	26.9/32.9	038	038	038	038
			CRHEATER328A00	16.0	12.0/14.7	41.0/50.1	038	038	038	038
			CRHEATER331A00	21.0	15.8/19.3	53.8/65.8	039	039	039	039
			CRHEATER332A00	24.5	18.4/22.5	62.8/76.8	039	039	039	039
		MED	CRHEATER324A00	6.5	4.9/6.0	16.7/20.4	—	—	037	037
			CRHEATER326A00	10.5	7.9/9.6	26.9/32.9	038	038	038	038
			CRHEATER328A00	16.0	12.0/14.7	41.0/50.1	038	038	038	038
			CRHEATER331A00	21.0	15.8/19.3	53.8/65.8	039	039	039	039
		HIGH	CRHEATER332A00	24.5	18.4/22.5	62.8/76.8	039	039	039	039
			CRHEATER324A00	6.5	4.9/6.0	16.7/20.4	—	037	037	037
			CRHEATER326A00	10.5	7.9/9.6	26.9/32.9	038	038	038	038
			CRHEATER328A00	16.0	12.0/14.7	41.0/50.1	038	038	038	038
			CRHEATER331A00	21.0	15.8/19.3	53.8/65.8	039	039	039	039
		460-3-60	STD	CRHEATER333A00	6.0	5.5	18.8	—	—	—
	CRHEATER335A00			11.5	10.6	36.0	—	—	—	—
	CRHEATER336A00			14.0	12.9	43.9	—	—	—	—
	CRHEATER337A00			21.5	19.7	67.4	037	037	037	037
	CRHEATER338A00			24.0	22.0	75.2	037	037	037	037
	MED		CRHEATER333A00	6.0	5.5	18.8	—	—	—	—
			CRHEATER335A00	11.5	10.6	36.0	—	—	—	—
			CRHEATER336A00	14.0	12.9	43.9	—	—	—	—
			CRHEATER337A00	21.5	19.7	67.4	037	037	037	037
	HIGH		CRHEATER338A00	24.0	22.0	75.2	037	037	037	037
CRHEATER333A00			6.0	5.5	18.8	—	—	—	—	
CRHEATER335A00			11.5	10.6	36.0	—	—	—	—	
CRHEATER336A00			14.0	12.9	43.9	—	—	—	—	
CRHEATER337A00			21.5	19.7	67.4	037	037	037	037	
575-3-60	STD		CRHEATER338A00	24.0	22.0	75.2	037	037	037	037
		CRHEATER340A00	15.0	13.8	47.0	—	—	—	—	
	MED	CRHEATER341A00	21.0	19.3	65.8	037	037	037	037	
		CRHEATER340A00	15.0	13.8	47.0	—	—	—	—	
	HIGH	CRHEATER341A00	21.0	19.3	65.8	037	037	037	037	
		CRHEATER340A00	15.0	13.8	47.0	—	—	—	—	
	575-3-60	STD	CRHEATER341A00	21.0	19.3	65.8	037	037	037	037
			CRHEATER340A00	15.0	13.8	47.0	—	—	—	—
		MED	CRHEATER341A00	21.0	19.3	65.8	037	037	037	037
			CRHEATER340A00	15.0	13.8	47.0	—	—	—	—
HIGH	CRHEATER341A00	21.0	19.3	65.8	037	037	037	037		
	CRHEATER340A00	15.0	13.8	47.0	—	—	—	—		

50FCQM07 ELECTRIC HEAT DATA — WITH NON-FUSED DISCONNECT

50FCQ UNIT SIZE	NOM. V-Ph-Hz	IFM TYPE	ELECTRIC HEATER PART NUMBER	NOM (kW)	APPLICATION (kW)	APPLICATION OUTPUT (MBH)	SINGLE POINT OR JUNCTION PART NUMBER CRSINGLEXXXA00			
							NO C.O. OR UNPOWERED C.O.		w/PWRD C.O.	
							NO P.E.	w/P.E. (pwrd fr/unit)	NO P.E.	w/P.E. (pwrd fr/unit)
M07	208/230-3-60	STD	CRHEATER324A00	6.5	4.9/6.0	16.7/20.4	037	037	037	037
			CRHEATER326A00	10.5	7.9/9.6	26.9/32.9	038	038	038	038
			CRHEATER328A00	16.0	12.0/14.7	41.0/50.1	038	038	038	038
			CRHEATER331A00	21.0	15.8/19.3	53.8/65.8	039	039	039	039
			CRHEATER332A00	24.5	18.4/22.5	62.8/76.8	039	039	039	039
		MED	CRHEATER324A00	6.5	4.9/6.0	16.7/20.4	037	037	037	037
			CRHEATER326A00	10.5	7.9/9.6	26.9/32.9	038	038	038	038
			CRHEATER328A00	16.0	12.0/14.7	41.0/50.1	038	038	038	038
			CRHEATER331A00	21.0	15.8/19.3	53.8/65.8	039	039	039	039
			CRHEATER332A00	24.5	18.4/22.5	62.8/76.8	039	039	039	039
		HIGH	CRHEATER324A00	6.5	4.9/6.0	16.7/20.4	037	037	037	037
			CRHEATER326A00	10.5	7.9/9.6	26.9/32.9	038	038	038	038
			CRHEATER328A00	16.0	12.0/14.7	41.0/50.1	038	038	038	038
			CRHEATER331A00	21.0	15.8/19.3	53.8/65.8	039	039	039	039
			CRHEATER332A00	24.5	18.4/22.5	62.8/76.8	039	039	039	039
	460-3-60	STD	CRHEATER333A00	6.0	5.5	18.8	—	—	—	—
			CRHEATER335A00	11.5	10.6	36.0	—	—	—	—
			CRHEATER336A00	14.0	12.9	43.9	—	—	—	—
			CRHEATER337A00	21.5	19.7	67.4	037	037	037	037
			CRHEATER338A00	24.0	22.0	75.2	037	037	037	037
		MED	CRHEATER333A00	6.0	5.5	18.8	—	—	—	—
			CRHEATER335A00	11.5	10.6	36.0	—	—	—	—
			CRHEATER336A00	14.0	12.9	43.9	—	—	—	—
			CRHEATER337A00	21.5	19.7	67.4	037	037	037	037
CRHEATER338A00			24.0	22.0	75.2	037	037	037	037	
HIGH		CRHEATER333A00	6.0	5.5	18.8	—	—	—	—	
		CRHEATER335A00	11.5	10.6	36.0	—	—	—	—	
		CRHEATER336A00	14.0	12.9	43.9	—	—	—	—	
		CRHEATER337A00	21.5	19.7	67.4	037	037	037	037	
		CRHEATER338A00	24.0	22.0	75.2	037	037	037	037	
575-3-60	STD	CRHEATER340A00	15.0	13.8	47.0	—	—	—	—	
		CRHEATER341A00	21.0	19.3	65.8	037	037	037	037	
	MED	CRHEATER340A00	15.0	13.8	47.0	—	—	—	—	
		CRHEATER341A00	21.0	19.3	65.8	037	037	037	037	
	HIGH	CRHEATER340A00	15.0	13.8	47.0	—	—	—	—	
		CRHEATER341A00	21.0	19.3	65.8	037	037	037	037	

TYPICAL CONTROL WIRING DIAGRAM — 50FCQA04-06 208-230, 460, 575/3/60 UNIT WITH ELECTRO-MECHANICAL CONTROL AND W7212 ECONOMIZER

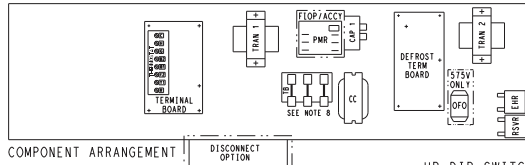

NOTES:

1. TERMINAL BOARD SCHEMATIC LAYOUT DOES NOT MATCH ACTUAL TERMINAL BOARD LAYOUT.
2. TERMINAL BOARD JUMPERS 1, 2 AND 3 ARE CUT FOR HEATPUMP UNITS.
3. REMOVE DESIGNATED JUMPERS ON TERMINAL BOARD WHEN ADDING SMOKE DETECTORS, OCCUPANCY AND REMOTE SHUTDOWN.
4. USE ABC AS COARSE AND AS POT FINE ADJUSTMENTS FOR SETTING HIGH FAN SPEED. LOW SPEED IS AN OFFSET BASED ON DIP SWITCHES.
5. 2-PIN LOW SPEED DIP SWITCH POSITIONS ARE FACTORY SET AS SHOWN.
6. HARDSTART AND CUTOFF SET TO "MIN". JUMPER PIN ON TOP 2-PINS AS SHOWN.
7. * WIRE COLOR IS FOR DIFFERENTIATION WITHIN THIS SCHEMATIC.
8. 3 PHASE UNIT SHOWN. ON 1 PHASE UNITS THIS IS A 2 POLE TERMINAL BLOCK.
9. TBA LOCATED IN HEAT SECTION.
10. TO CONVERT TO A SINGLE STAGE HEATER MOVE VIOLET WIRE AT TBA TO CONNECT WITH WHITE WIRE.



- 1) MOMENTARILY SHORT PINS AND RELEASE TO BYPASS COMPRESSOR OFF DELAY.
- 2) SHORT FOR 1-TO SEC. AND RELEASE FOR FORCED DEFOREST.
- 3) PERMANENT SHORT WILL BE IGNORED. DEFOREST WILL TERMINATE IN 30 SEC. IF DFT IS OPEN. DEFOREST WILL TERMINATE NORMALLY IF DFT IS CLOSED.

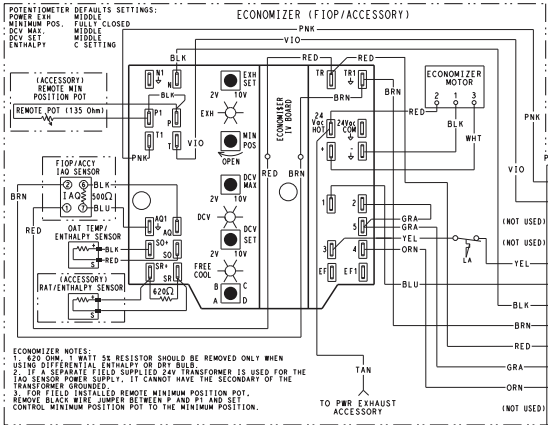
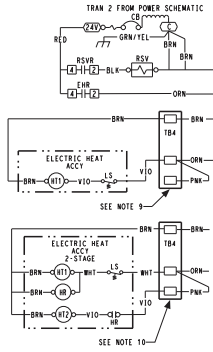

- ECONOMIZER NOTES:**
1. 400 OHM 1/2 W RESISTOR SHOULD BE REMOVED WHEN USING OPERATIONAL ENTALPT SENSOR OR PRAISE TRANSFORMER IS USED FOR THE TAG SENSOR POWER SUPPLY. IT CANNOT HAVE THE SECONDARY OF THE TRANSFORMER GROUNDED.
 2. FOR FIELD INSTALLED REMOTE MINIMUM POSITION POT. REMOVE BLACK WIRE JUMPER BETWEEN P AND M1 AND SET CONTROL MINIMUM POSITION POT TO THE MINIMUM POSITION.

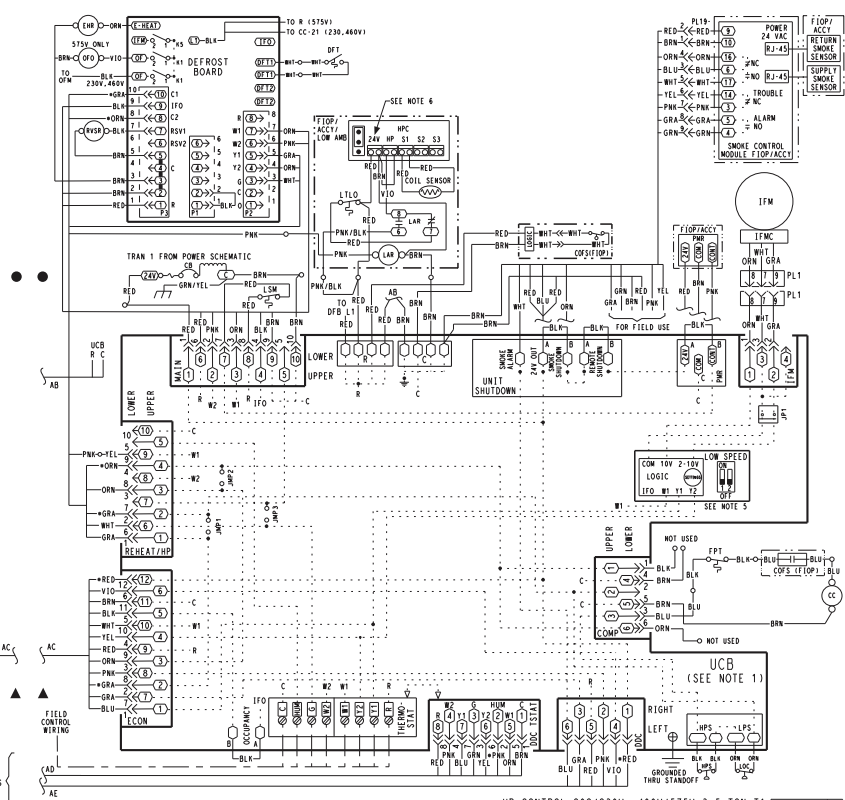
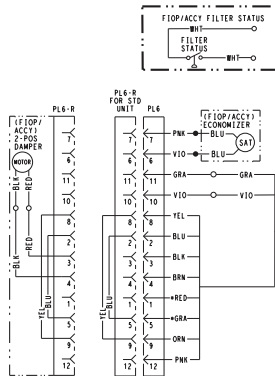

- POWER**
- RED << RED-1
 - BRN << BRN-1
 - ORN << ORN-1
 - BLU << BLU-1
 - WHT << WHT-1
 - GRN << GRN-1
- FIOP/ACCY**
- RED << RED-1
 - BRN << BRN-1
 - ORN << ORN-1
 - BLU << BLU-1
 - WHT << WHT-1
 - GRN << GRN-1
- SMOKE CONTROL MODULE (FIOP/ACCY)**
- WHT << WHT-1
 - RED << RED-1
 - BLU << BLU-1
 - ORN << ORN-1
 - GRN << GRN-1

HP CONTROL 208/230V, 460V/575V 3-5 TON T1 48TC003166 A



TYPICAL CONTROL WIRING DIAGRAM — 50FCQA04-06 208-230, 460, 575/3/60 UNIT WITH ELECTRO-MECHANICAL CONTROL AND W7220 ECONOMIZER

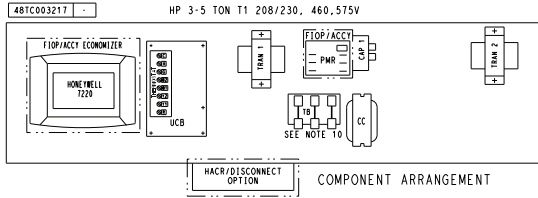

- NOTES:
1. TERMINAL BOARD SCHEMATIC LAYOUT DOES NOT MATCH ACTUAL TERMINAL BOARD LAYOUT.
 2. TERMINAL BOARD JUMPERS 1, 2 AND 3 ARE CUT FOR REHEAT UNITS ONLY.
 3. REMOVE DESIGNATED JUMPERS ON TERMINAL BOARD WHEN ADDING SMOKE DETECTORS, OCCUPANCY AND REMOTE SHUTDOWN.
 4. USE ABC AS COURSE AND POT AS FINE ADJUSTMENTS FOR SETTING HIGH FAN SPEED. LOW SPEED IS AN OFFSET BASED ON DIP SWITCHES.
 5. 2-PIN LOW SPEED DIP SWITCH POSITIONS ARE FACTORY SET AS SHOWN.
 6. HADJUST START AND CUTOFF SET TO "MIN". JUMPER PIN ON TOP 2-PINS AS SHOWN.
 7. THE * WIRE COLOR IS FOR DIFFERENTIATION WITHIN THIS SCHEMATIC.
 8. TBA LOCATED IN HEAT SECTION.
 9. TO CONVERT TO A SINGLE STAGE HEATER MOVE VIOLET WIRE AT TBA TO CONNECT WITH WHITE WIRE.
 10. 3 PHASE UNIT SHOWN, ON 1 PHASE UNITS THIS IS A 2 POLE TERMINAL BLOCK.

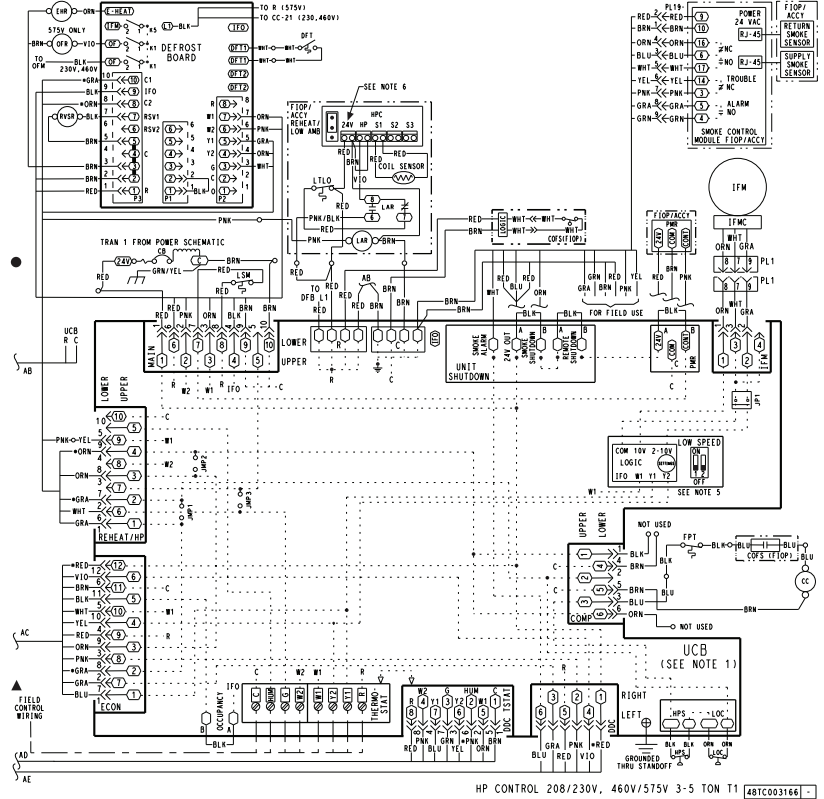
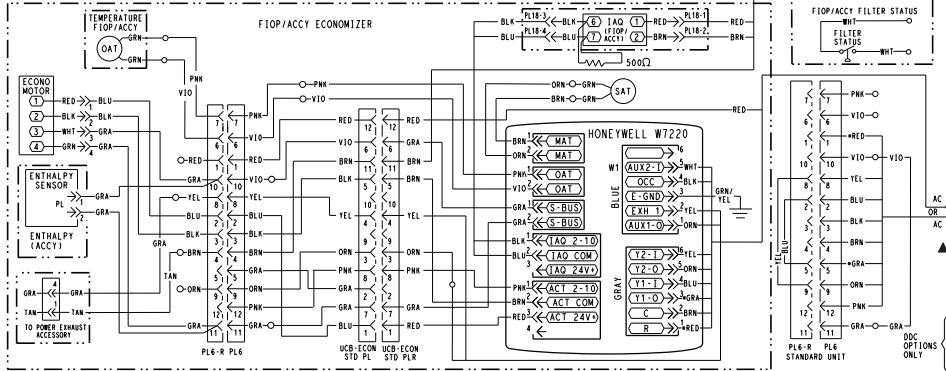
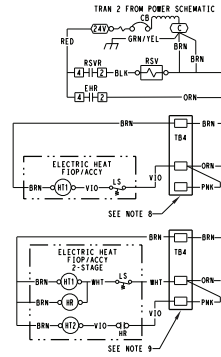
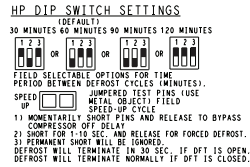

TYPICAL CONTROL WIRING DIAGRAM — 50FCQM07 208-230/3/60 UNIT WITH ELECTRO-MECHANICAL CONTROL AND W7220 ECONOMIZER

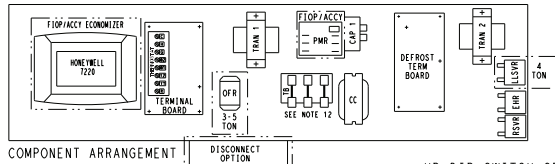

- NOTES:**
1. TERMINAL BOARD SCHEMATIC LAYOUT DOES NOT MATCH ACTUAL TERMINAL BOARD LAYOUT.
 2. TERMINAL BOARD JUMPERS 1, 2 AND 3 ARE CUT FOR HEATPUMP UNITS.
 3. REMOVE DESIGNATED JUMPERS ON TERMINAL BOARD WHEN ADDING SMOKE DETECTORS, OCCUPANCY AND REMOTE SHUTDOWN.
 4. USE ABC AS CHARGE AND AS POT FINE ADJUSTMENTS FOR SETTING HIGH FAN SPEED. LOW SPEED IS AN OFFSET BASED ON DIP SWITCHES.
 5. 2-PIN LOW SPEED DIP SWITCH POSITIONS ARE FACTORY SET AS SHOWN. HARDBSTART AND CUTOFF SET TO "MIN". JUMPER PIN ON TOP 2-PINS AS SHOWN.
 6. * WIRE COLOR IS FOR DIFFERENTIATION WITHIN THIS SCHEMATIC.
 7. COMPRESSOR LEADER PLUG CONTAINS BRIDGE RECTIFIER TO CONVERT AC TO DC.
 8. TBA LOCATED IN HEAT SECTION.
 9. TO CONVERT TO A SINGLE STAGE HEATER MOVE VIOLETT WIRE AT TBA TO CONNECT WITH WHITE WIRE.
 10. ON 3 & 5 TON UNITS, PINK FROM HPC CONNECTS DIRECTLY TO YEL FROM PIN 5.
 11. ON 3 & 5 TON UNITS, PINK FROM HPC CONNECTS DIRECTLY TO YEL FROM PIN 5.
 12. 3 PHASE UNIT SHOWN, ON 1 PHASE UNITS THIS IS A 2 POLE TERMINAL BLOCK.

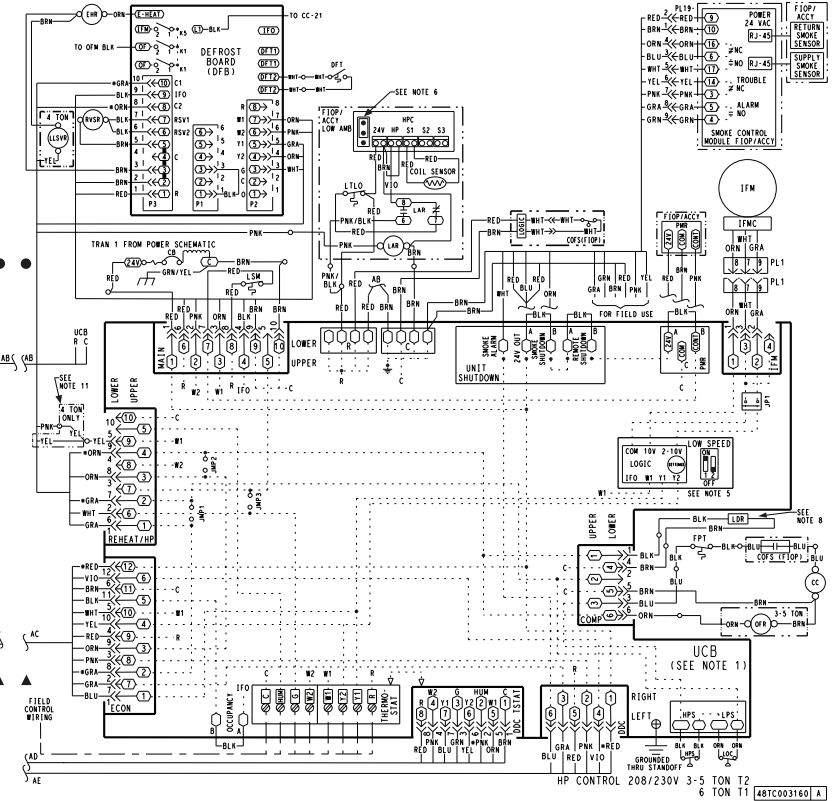
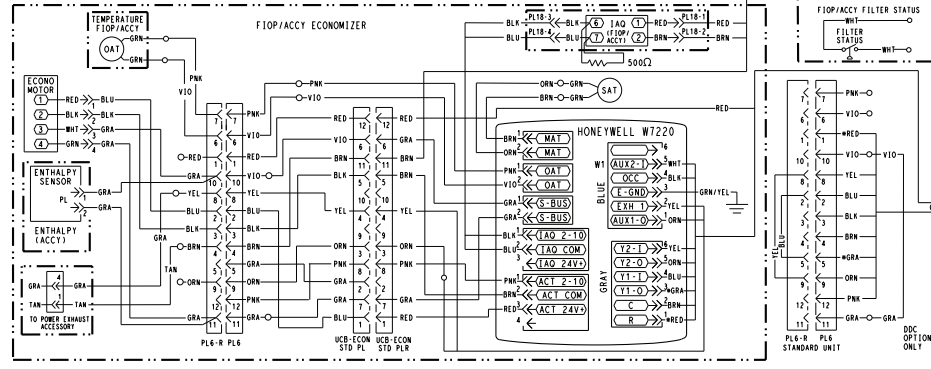
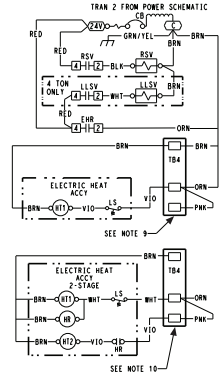
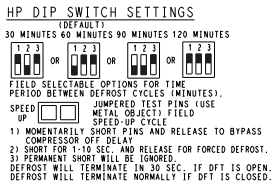

TYPICAL CONTROL WIRING DIAGRAM — 50FCQM07 460-575/3/60 UNIT WITH ELECTRO-MECHANICAL CONTROL AND W7220 ECONOMIZER

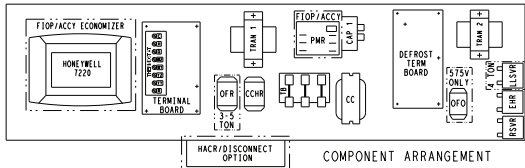

- NOTES:**
1. TERMINAL BOARD SCHEMATIC LAYOUT DOES NOT MATCH ACTUAL TERMINAL BOARD LAYOUT.
 2. TERMINAL BOARD JUMPERS 1, 2 AND 3 ARE CUT FOR REHEAT UNITS ONLY.
 3. REMOVE DESIGNATED JUMPERS ON TERMINAL BOARD WHEN ADDING SMOKE DETECTORS, OCCUPANCY AND REMOTE SHUTDOWN.
 4. USE ABC AS COURSE AND POT AS FINE ADJUSTMENTS FOR SETTING HIGH FAN SPEED. LOW SPEED IS AN OFFSET BASED ON DIP SWITCHES.
 5. 2-PIN LOW SPEED DIP SWITCH POSITIONS ARE FACTORY SET AS SHOWN.
 6. HARDSTART AND CUTOFF SET TO "MIN". JUMPER PIN ON TOP 2-PINS AS SHOWN.
 7. THE "W" WIRE COLOR IS FOR DIFFERENTIATION WITHIN THIS SCHEMATIC.
 8. COMPRESSOR LOWER PULG CONTAINS BRIDGE RECTIFIER TO CONVERT AC TO DC.
 9. TB4 LOCATED IN HEAT SECTION.
 10. TO CONVERT TO A SINGLE STAGE HEATER MOVE VIOLET WIRE AT TB4 TO CONNECT WITH WHITE WIRE.
 11. ON 3 & 5 TON UNITS, PAK FROM HPC CONNECTS DIRECTLY TO YEL FROM PIN ②

HP DIP SWITCH SETTINGS

- 30 MINUTES (DEFAULT) 60 MINUTES 90 MINUTES 120 MINUTES
- 1 2 3 1 2 3 1 2 3 1 2 3
- FIELD SELECTABLE OPTIONS FOR TIME PERIOD BETWEEN DEFROST CYCLES (MINUTES).
- SPEED JUMPERED TEST PINS (USE UP METAL OBJECT) FIELD SPEED UP CYCLE
1. MOMENTARILY SHORT PINS AND RELEASE TO BYPASS COMPRESSOR OFF DELAY.
 2. SHORT FOR 1-10 SEC. AND RELEASE FOR FORCED DEFROST. PERMANENT SHORT WILL BE IGNORED.
 3. PERMANENT SHORT WILL BE IGNORED. DEFROST WILL TERMINATE IN 30 SEC. IF DFT IS OPEN. DEFROST WILL TERMINATE NORMALLY IF DFT IS CLOSED.

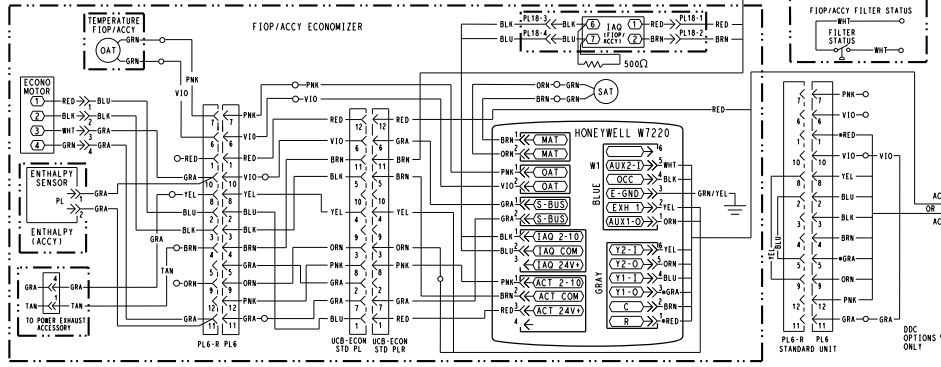
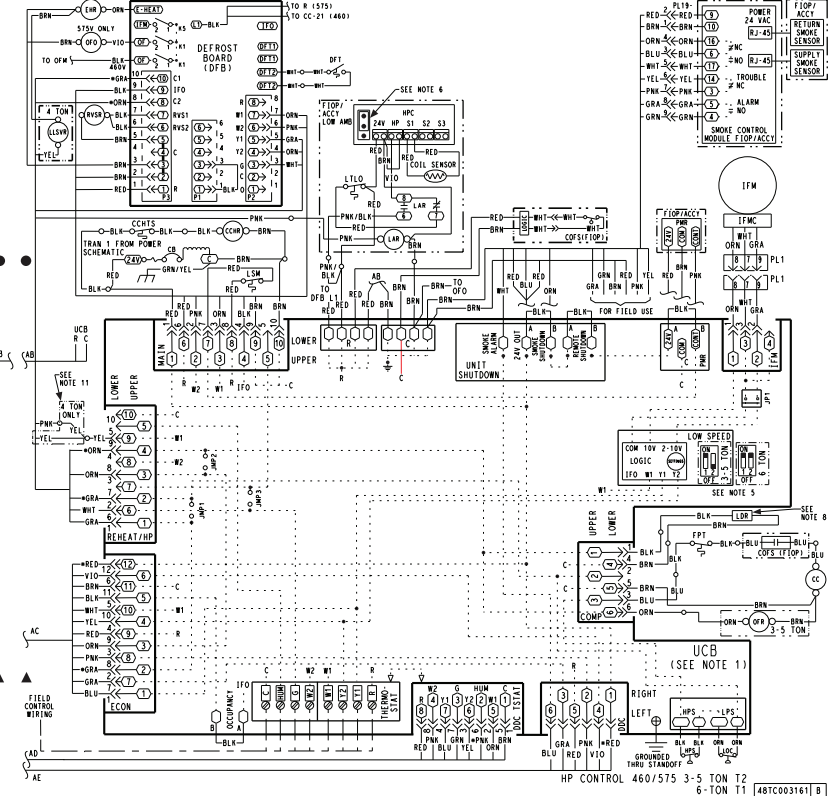
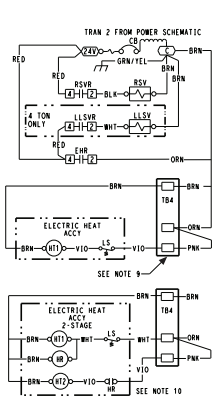

TYPICAL CONTROL WIRING DIAGRAM — 50FCQA04-06 208/230, 460, 575/3/60 UNIT WITH SYSTEMVU CONTROLLER

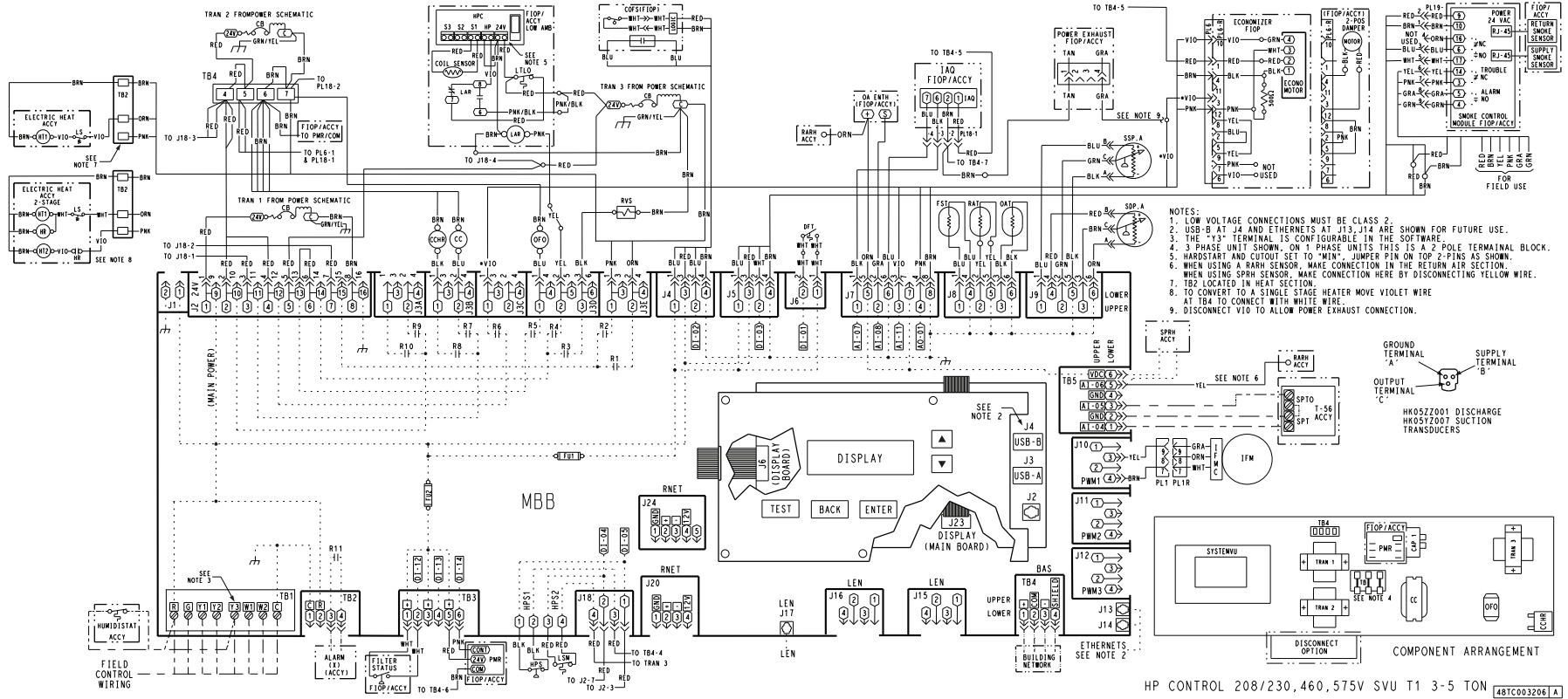

TYPICAL CONTROL WIRING DIAGRAM — 50FCQM07 208/230, 460, 575/3/60 UNIT WITH SYSTEMVU CONTROLLER

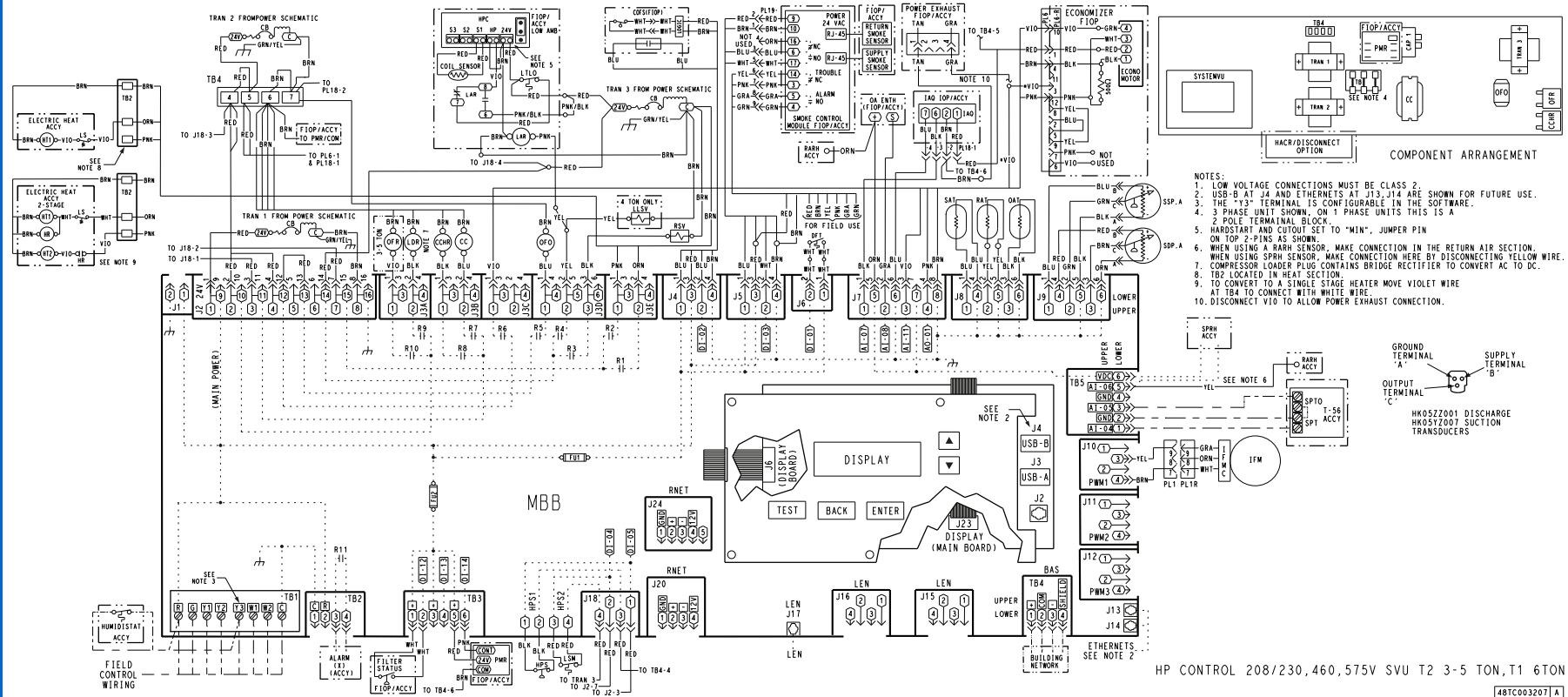

TYPICAL CONTROL WIRING DIAGRAM — 50FCQA04-06 208/230, 460, 575/3/60 UNIT WITH RTU OPEN CONTROLLER

48TC003214-1 HP 3-5 TON T2 & 3-6 TON T1 208/230,460,575V RTU OPEN

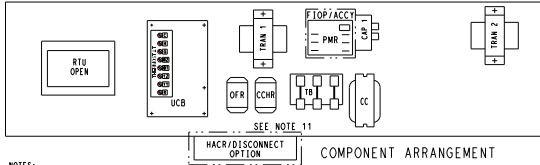

- NOTES:**
- TERMINAL BOARD SCHEMATIC LAYOUT DOES NOT MATCH ACTUAL TERMINAL BOARD LAYOUT.
 - TERMINAL BOARD JUMPERS 1, 2 AND 3 ARE CUT FOR REHEAT UNITS ONLY.
 - REMOVE DISCONNECTED JUMPERS ON TERMINAL BOARD WHEN ADDING SMOKE DETECTORS, OCCUPANCY AND REMOTE SHUTDOWN.
 - NOT USED ON RTU OPEN.
 - USE RTU OPEN SETTING TO ADJUST FAN SPEED.
 - HARDSTART AND CUTOFF SET TO "MIN". JUMPER PIN ON TOP 2-PINS AS SHOWN.
 - THE # WIRE COLOR IS FOR DIFFERENTIATION WITHIN THIS SCHEMATIC.
 - COMPRESSOR LEADER PLUG CONTAINS BRIDGE RECTIFIER TO CONVERT AC TO DC.
 - TBA LOCATED IN THE HEAT SECTION.
 - TO CONVERT TO A SINGLE STAGE HEATER MOVE VIOLET WIRE AT TBA TO CONNECT WITH WHITE WIRE.
 - COMPONENTS MAY VARY BASED ON EXACT PRODUCT AND OPTIONS.
 - FOLLOW THIS WIRING FOR IFM CONNECTOR WITH RTU OPEN. IGNORE IFM WIRING AT UCB.

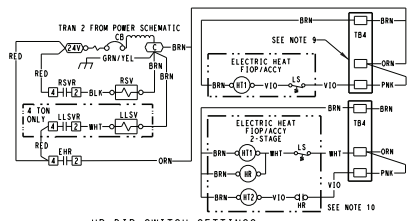

HP DIP SWITCH SETTINGS

- (DEFAULT)
- 30 MINUTES 60 MINUTES 90 MINUTES 120 MINUTES

FIELD SELECTABLE OPTIONS FOR TIME PERIOD BETWEEN DEFOST CYCLES (MINUTES).

JUMPERED TEST PINS (USE SPEED UP OR SPEED DOWN CYCLE)

1) MOMENTARILY SHORT PINS AND RELEASE TO BYPASS COMPRESSOR OFF DELAY.

2) SHORT FOR 1-10 SEC. AND RELEASE FOR FORCED DEFOST. DEFOST WILL TERMINATE IN 30 SEC. IF DFT IS OPEN.

3) PERMANENT SHORT WILL BE IGNORED. DEFOST WILL TERMINATE NORMALLY IF DFT IS CLOSED.

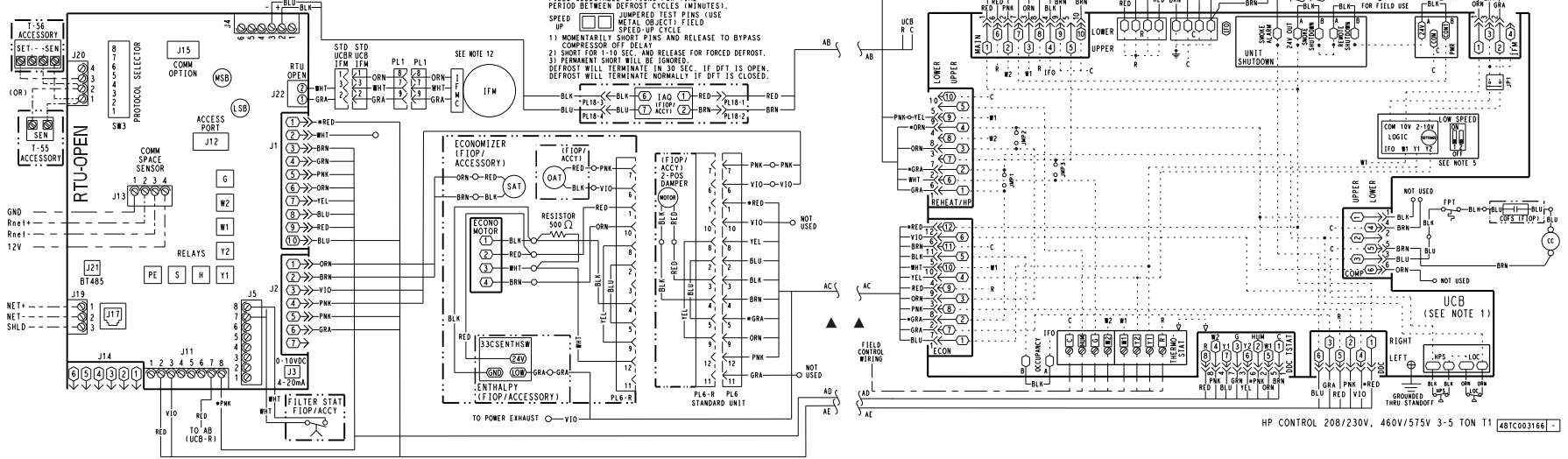

TYPICAL CONTROL WIRING DIAGRAM — 50FCQM07 208/230, 460, 575/3/60 UNIT WITH RTU OPEN CONTROLLER

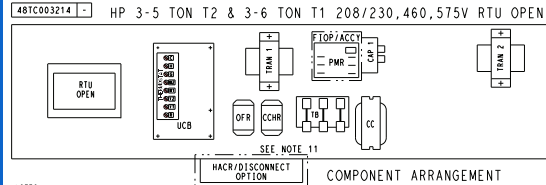

- NOTES:**
- TERMINAL BOARD SCHEMATIC LAYOUT DOES NOT MATCH ACTUAL TERMINAL BOARD LAYOUT.
 - TERMINAL BOARD JUMPERS 1, 2 AND 3 ARE CUT FOR REHEAT UNITS ONLY.
 - REMOVE DESIGNATED JUMPERS ON TERMINAL BOARD WHEN ADDING SMOKE DETECTORS, OCCUPANCY AND REMOTE SHUTDOWN.
 - NOT USED ON RTU OPEN.
 - USE RTU OPEN SETTING TO ADJUST FAN SPEED.
 - HARDSTART AND CUTOFF SET TO "MIN". JUMPER PIN ON TOP 2-PINS AS SHOWN.
 - THE # WIRE COLOR IS FOR DIFFERENTIATION WITHIN THIS SCHEMATIC.
 - COMPRESSOR LOADER PLUG CONTAINS BRIDGE RECTIFIER TO CONVERT AC TO DC.
 - TRN 1 LOCATED IN THE HEAT SECTION.
 - TO CONVERT TO A SINGLE STAGE HEATER MOVE VIOLET WIRE AT TB4 TO CONNECT WITH WHITE WIRE.
 - COMPONENTS MAY VARY BASED ON EXACT PRODUCT AND OPTIONS.
 - FOLLOW THIS WIRING FOR IFM CONNECTOR WITH RTU OPEN. IGNORE IFM WIRING AT UCB.

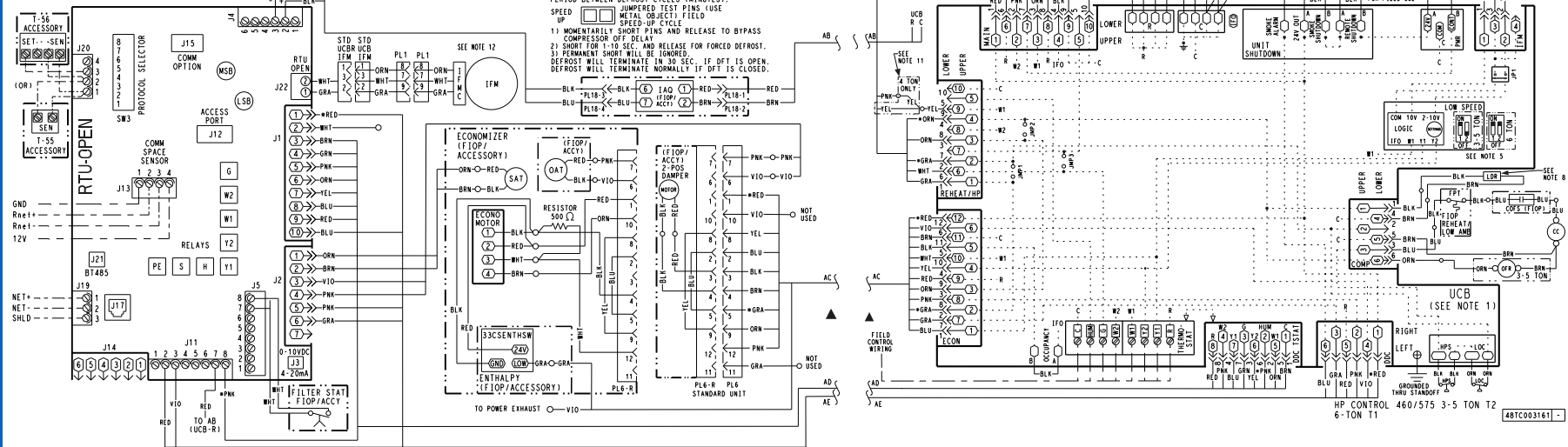
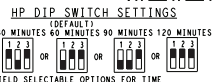
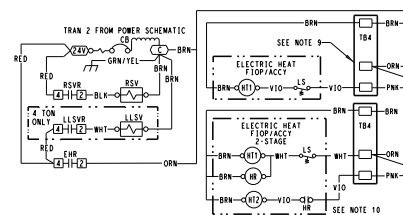

TYPICAL 50FCQA04-06 POWER WIRING DIAGRAM, 208-230/1/60 UNIT

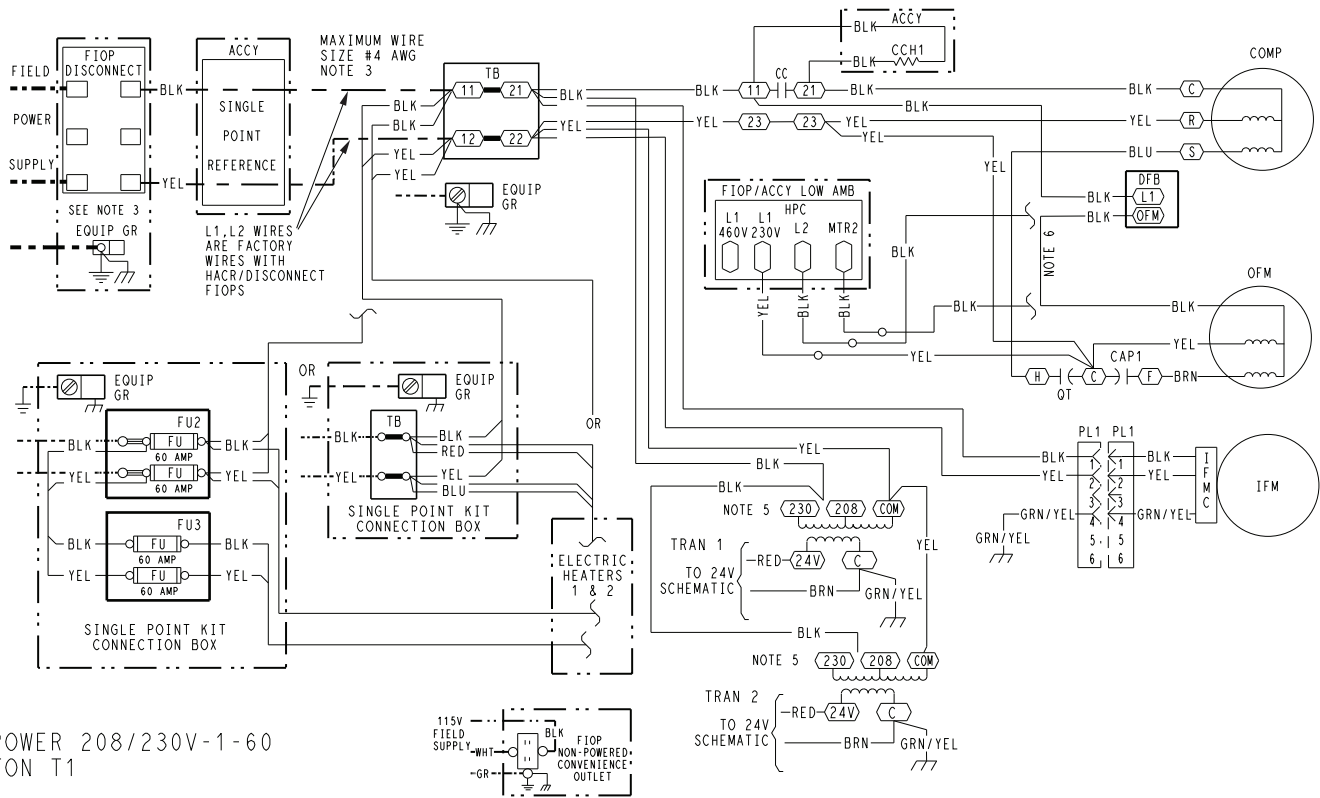

HP POWER 208/230V-1-60
3-5TON T1

NOTES

- IF ANY OF THE ORIGINAL WIRE FURNISHED MUST BE REPLACED, IT MUST BE REPLACED WITH TYPE 90° C WIRE OR ITS EQUIVALENT.
- COMPRESSOR AND FAN MOTORS ARE THERMALLY PROTECTED.
- USE COPPER CONDUCTOR ONLY.
- DO NOT DISCONNECT POWER PLUG OR SIGNAL WIRE WHILE UNDER LOAD.
- ON 208/230V UNITS, TRAN IS WIRED FOR 230V. IF UNIT IS TO BE RUN WITH 208V POWER SUPPLY, DISCONNECT BLK WIRE FROM 230V TAP AND CONNECT TO 208V TAP.
- THIS WIRE NOT USED WITH LOW AMBIENT FIOP/ACCY.

LEGEND

- MARKED WIRE
- TERMINAL (MARKED)
- TERMINAL (UNMARKED)
- TERMINAL BLOCK
- SPLICE
- SPLICE (MARKED)
- FACTORY WIRING
- FIELD CONTROL WIRING
- FIELD POWER WIRING
- CIRCUIT BOARD TRACE
- ACCESSORY OR OPTIONAL WIRING

- ACCY ACCESSORY
- AWG AMERICAN WIRE GAGE
- BAS BUILDING AUTOMATION NETWORK
- CC CONTACTOR, COMPRESSOR
- C COMMON
- CAP CAPACITOR
- CB CIRCUIT BREAKER
- CCH CRANKCASE HEATER
- CCHR CRANKCASE HEATER RELAY
- CCHT S CRANKCASE HEATER TEMP SWITCH
- CLO COMPRESSOR LOCKOUT
- CLV COOLING LIQUID VALVE
- COPS CONDENSATE OVERFLOW SWITCH
- COM SIGNAL COMMON
- COMP COMPRESSOR MOTOR
- DDC DIRECT DIGITAL CONTROL
- DFB DEFROST BOARD
- DFT DEFROST THERMOSTAT
- EHR ELECTRIC HEAT RELAY
- ENTH ENTHALPY
- ERV ENERGY RECOVERY VENTILATOR
- ESL ENTHALPY SENSOR - LOW
- FB FUSE BLOCK
- FIOP FACTORY INSTALLED OPTION
- FPT FREEZE PROTECTION THERMOSTAT
- FST FAN HOUSING TEMP SENSOR
- FU FUSE
- G THERMOSTAT FAN CALL
- GR(GND) GROUND
- HACR HEATING, AIR-CONDITIONING, REFRIGERATION BREAKER

- HR HEATER RELAY
- HGRH HOT GAS REHEAT
- HPC HEAD PRESSURE CONTROL
- HPS HIGH PRESSURE SWITCH
- HUM HUMIDISTAT
- IAQ INDOOR AIR QUALITY SENSORS
- IFMC INDOOR FAN MOTOR CONTROL
- IFO INDOOR FAN ON SIGNAL
- IRH INDOOR RELATIVE HUMIDITY
- JMP JUMPER
- L1 LINE 1
- LA LOW AMBIENT LOCKOUT
- LAR LOW AMBIENT RELAY
- LAS LOW AMBIENT SWITCH
- LDR COMPRESSOR LOADER
- LEN LOCAL EQUIPMENT NETWORK
- LOC LOSS OF CHARGE
- LPS LOW PRESSURE SWITCH
- LS LIMIT SWITCH
- LSM LIMIT SWITCH (MANUAL RESET)
- LTL0 LOW TEMP LOCKOUT
- MTR MOTOR
- OAO OUTDOOR AIR QUALITY
- OAT OUTDOOR AIR TEMP. SEN
- OFM OUTDOOR FAN MOTOR
- OFR OUTDOOR FAN RELAY
- OL OVERLOAD

- PER POWER EXHAUST RELAY
- PH PHASE
- PL PLUG ASSEMBLY
- POT POTENTIOMETER
- PMR PHASE MONITOR RELAY
- PS PRESSURE SWITCH
- PWM PULSE WIDTH MODULATION
- QT QUADRUPLE TERMINAL
- R THERMOSTAT POWER
- RAT RETURN AIR TEMP. SEN
- RDV REHEAT DISCHARGE VALVE
- RH RELATIVE HUMIDITY
- RLV REHEAT LIQUID VALVE
- RNET LOCAL ACCESS NETWORK
- RVS REVERSING VALVE SOLENOID
- SAT SUPPLY AIR TEMP SENSOR
- SDP SYSTEM DISCHARGE PRESSURE
- SPRH SPACE RELATIVE HUMIDITY
- SPT SPACE TEMPERATURE SENSOR
- SPTO SPACE TEMPERATURE OFFSET
- SSP SYSTEM SUCTION PRESSURE
- SW SWITCH
- TB TERMINAL BLOCK
- TDR TIME DELAY RELAY
- TRAN TRANSFORMER
- UCB UNIT CONTROL BOARD
- W1 1st STAGE OF HEATING CALL
- W2 2nd STAGE OF HEATING CALL
- Y1 1st STAGE OF COOLING CALL
- Y2 2nd STAGE OF COOLING CALL

48TC003163 | A

TYPICAL 50FCQ 04-07 POWER WIRING DIAGRAM, 208-230/3/60 UNIT

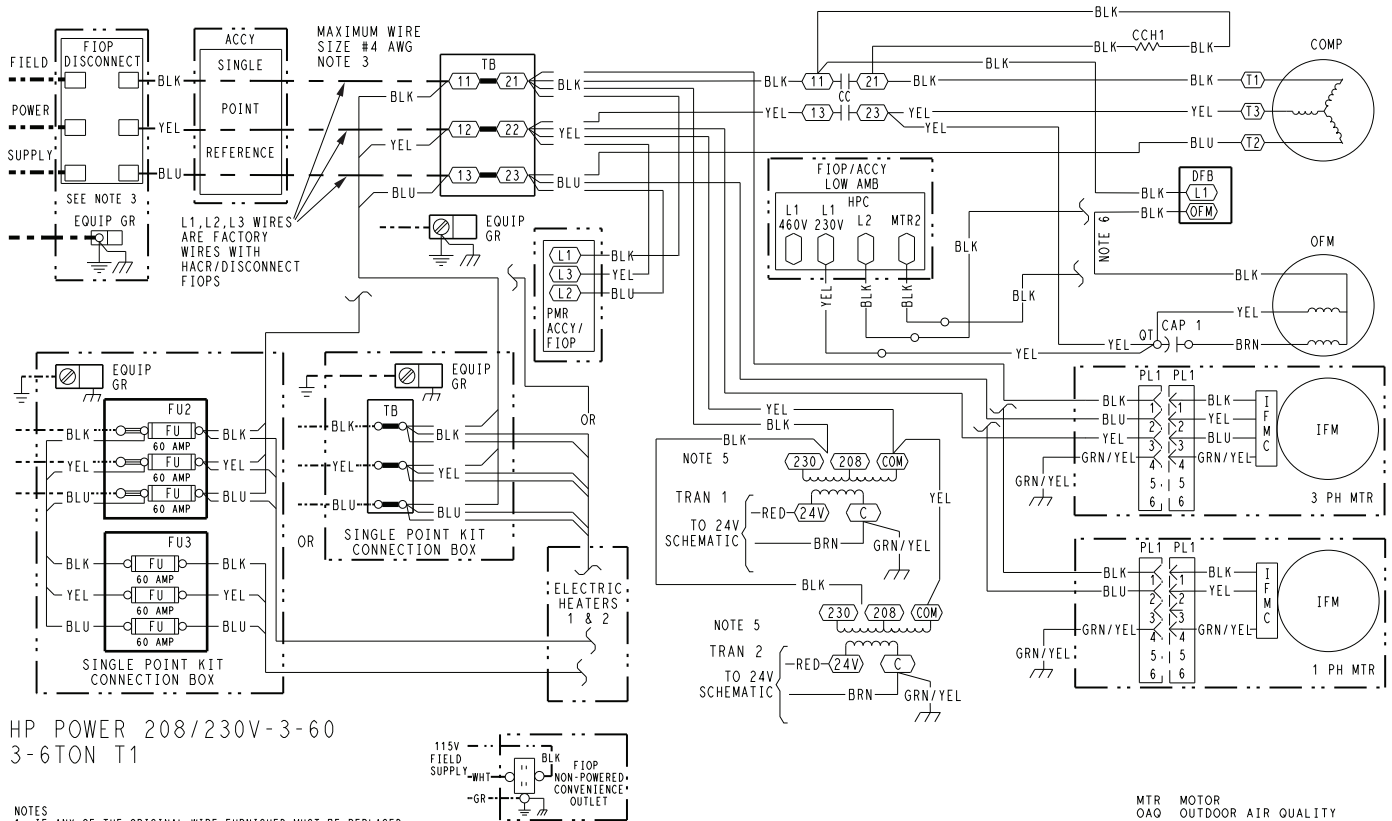

48TC003162 | A

TYPICAL 50FCQ 04-07 POWER WIRING DIAGRAM, 460-575/3/60

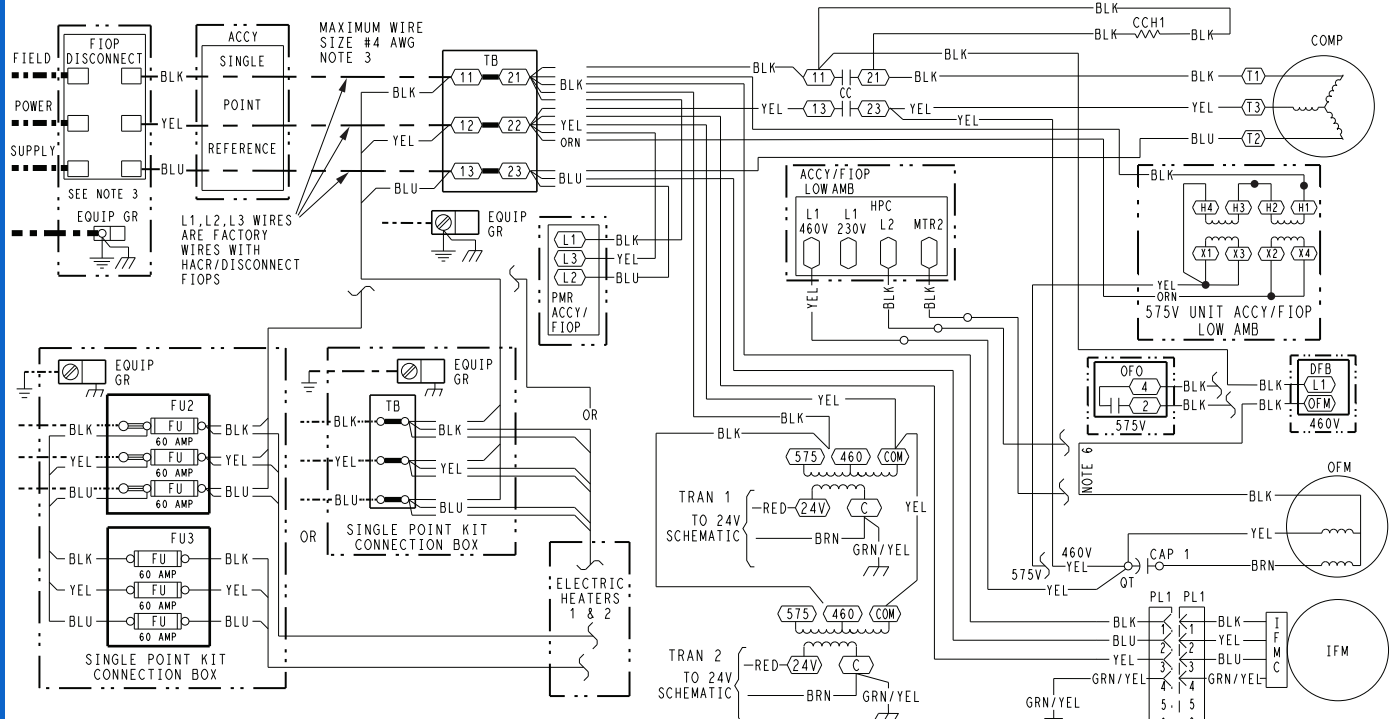

HP POWER 460/575V-3-60
3-6TON T1

- NOTES**
1. IF ANY OF THE ORIGINAL WIRE FURNISHED MUST BE REPLACED. IT MUST BE REPLACED WITH TYPE 90° C WIRE OR ITS EQUIVALENT.
 2. COMPRESSOR AND FAN MOTORS ARE THERMALLY PROTECTED.
 3. USE COPPER CONDUCTOR ONLY.
 4. DO NOT DISCONNECT POWER PLUG OR SIGNAL WIRE WHILE UNDER LOAD.
 5. TRANSFORMER IS DEDICATED BASED ON UNIT VOLTAGE. TAPS ONLY SHOWN TO SIMPLIFY SCHEMATIC.
 6. THIS WIRE NOT USED WITH LOW AMBIENT FIOP/ACCY.

LEGEND

- (X) MARKED WIRE
- (X) TERMINAL (MARKED)
- () TERMINAL (UNMARKED)
- (X) TERMINAL BLOCK
- SPLICE
- SPLICE (MARKED)
- FACTORY WIRING
- - - FIELD CONTROL WIRING
- - - - FIELD POWER WIRING
- - - - - CIRCUIT BOARD TRACE
- - - - - ACCESSORY OR OPTIONAL WIRING

- ACCY ACCESSORY
- AWG AMERICAN WIRE GAGE
- BAS BUILDING AUTOMATION NETWORK
- CC CONTACTOR, COMPRESSOR
- C COMMON
- CAP CAPACITOR
- CB CIRCUIT BREAKER
- CCH CRANKCASE HEATER
- CCHR CRANKCASE HEATER RELAY
- CCHTS CRANKCASE HEATER TEMP SWITCH
- CLO COMPRESSOR LOCKOUT
- CLV COOLING LIQUID VALVE
- CLFS CONDENSATE OVERFLOW SWITCH
- COM SIGNAL COMMON
- COMP COMPRESSOR MOTOR
- DDC DIRECT DIGITAL CONTROL
- DFB DEFROST BOARD
- DFT DEFROST THERMOSTAT
- EHR ELECTRIC HEAT RELAY
- ENTH ENTHALPY
- ERV ENERGY RECOVERY VENTILATOR
- ESL ENTHALPY SENSOR - LOW
- FB FUSE BLOCK
- FIOP FACTORY INSTALLED OPTION
- FPT FREEZE PROTECTION THERMOSTAT
- FST FAN HOUSING TEMP SENSOR
- FU FUSE

- G THERMOSTAT FAN CALL
- GR(GND) GROUND
- HACR HEATING, AIR-CONDITIONING, REFRIGERATION BREAKER
- HR HEATER RELAY
- HGRH HOT GAS REHEAT
- HPC HEAD PRESSURE CONTROL
- HPS HIGH PRESSURE SWITCH
- HUM HUMIDISTAT
- IAO INDOOR AIR QUALITY SENSORS
- IFM INDOOR FAN MOTOR
- IFMC INDOOR FAN MOTOR CONTROL
- IFO INDOOR FAN ON SIGNAL
- IRH INDOOR RELATIVE HUMIDITY
- JMP JUMPER
- L1 LINE 1
- LA LOW AMBIENT LOCKOUT
- LAR LOW AMBIENT RELAY
- LAS LOW AMBIENT SWITCH
- LDR COMPRESSOR LOADER
- LEN LOCAL EQUIPMENT NETWORK
- LOC LOSS OF CHARGE
- LOOP CURRENT LOOP POWER
- LPS LOW PRESSURE SWITCH
- LS LIMIT SWITCH
- LSM LIMIT SWITCH (MANUAL RESET)
- LTL0 LOW TEMP LOCKOUT

- MBB MAIN BASE BOARD
- MOV METAL OXIDE VARISTOR
- MTR MOTOR
- OAQ OUTDOOR AIR QUALITY
- OAT OUTDOOR AIR TEMP SEN
- OFM OUTDOOR FAN MOTOR
- OFO OUTDOOR FAN ON RELAY
- OFR OUTDOOR FAN RELAY
- OL OVERLOAD
- PER POWER EXHAUST RELAY
- PH PHASE
- PL PLUG ASSEMBLY
- POT POTENTIOMETER
- PMR PHASE MONITOR RELAY
- PS PRESSURE SWITCH
- PWM PULSE WIDTH MODULATION
- QT QUADRUPLE TERMINAL
- R THERMOSTAT POWER
- RAT RETURN AIR TEMP. SEN
- RDV REHEAT DISCHARGE VALVE
- RH RELATIVE HUMIDITY
- RLV REHEAT LIQUID VALVE
- RNET LOCAL ACCESS NETWORK
- RVS REVERSING VALVE SOLENOID
- SAT SUPPLY AIR TEMP SENSOR
- SAT SYSTEM DISCHARGE PRESSURE
- SDPH SPACE RELATIVE HUMIDITY
- SPT SPACE TEMPERATURE SENSOR
- SPTO SPACE TEMPERATURE OFFSET
- SSP SYSTEM SUCTION PRESSURE
- SW SWITCH
- TB TERMINAL BLOCK
- TDR TIME DELAY RELAY
- UCB UNIT CONTROL BOARD
- TRAN TRANSFORMER
- W1 1st STAGE OF HEATING CALL
- W2 2nd STAGE OF HEATING CALL
- Y1 1st STAGE OF COOLING CALL
- Y2 2nd STAGE OF COOLING CALL

48TC003164 A

TYPICAL 50FCQ 04-06 POWER WIRING DIAGRAM, 208-230/1/60 UNIT WITH SYSTEMVU CONTROLLER

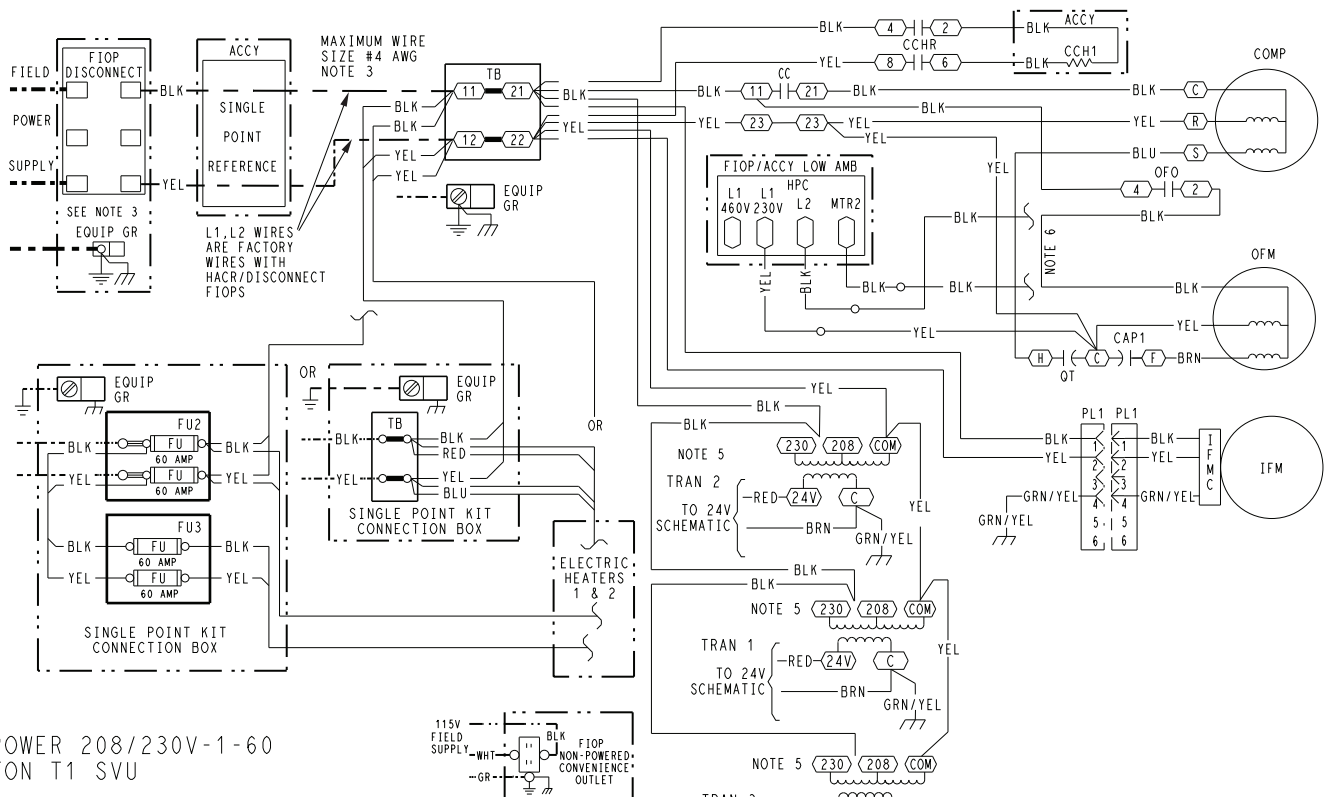

HP POWER 208/230V-1-60
3-5TON T1 SVU

- NOTES**
- IF ANY OF THE ORIGINAL WIRE FURNISHED MUST BE REPLACED. IT MUST BE REPLACED WITH TYPE 90° C WIRE OR ITS EQUIVALENT.
 - COMPRESSOR AND FAN MOTORS ARE THERMALLY PROTECTED.
 - USE COPPER CONDUCTOR ONLY.
 - DO NOT DISCONNECT POWER PLUG OR SIGNAL WIRE WHILE UNDER LOAD.
 - ON 208/230V UNITS, TRAN IS WIRED FOR 230V. IF UNIT IS TO BE RUN WITH 208V POWER SUPPLY, DISCONNECT BLK WIRE FROM 230V TAP AND CONNECT TO 208V TAP.
 - THIS WIRE NOT USED WITH LOW AMBIENT FIO/ACCY.

LEGEND

- (X) MARKED WIRE
- (X) TERMINAL (MARKED)
- () TERMINAL (UNMARKED)
- (X) TERMINAL BLOCK
- SPLICE
- SPLICE (MARKED)
- FACTORY WIRING
- - - FIELD CONTROL WIRING
- - - - - FIELD POWER WIRING
- - - - - CIRCUIT BOARD TRACE
- - - - - ACCESSORY OR OPTIONAL WIRING

ACCY	ACCESSORY	HR	HEATER RELAY	PER	POWER EXHAUST RELAY
AWG	AMERICAN WIRE GAGE	HGRH	HOT GAS REHEAT	PH	PHASE
BAS	BUILDING AUTOMATION NETWORK	HPC	HEAD PRESSURE SWITCH	PL	PLUG ASSEMBLY
CC	CONTACTOR, COMPRESSOR COMMON	HPS	HIGH PRESSURE SWITCH	POT	POTENTIOMETER
C	CAPACITOR	HUM	HUMIDISTAT	PMR	PHASE MONITOR RELAY
CB	CIRCUIT BREAKER	IAQ	INDOOR AIR QUALITY SENSORS	PS	PRESSURE SWITCH
CCH	CRANKCASE HEATER	IFM	INDOOR FAN MOTOR	PSW	PULSE WIDTH MODULATION
CCHR	CRANKCASE HEATER RELAY	IFMC	INDOOR FAN MOTOR CONTROL	PWM	PULSE WIDTH MODULATION
CCHTS	CRANKCASE HEATER TEMP SWITCH	IFO	INDOOR FAN ON SIGNAL	Q	QUADRUPLE TERMINAL
CLO	COMPRESSOR LOCKOUT	IRH	INDOOR RELATIVE HUMIDITY	R	THERMOSTAT POWER
CLV	COOLING LIQUID VALVE	JMP	JUMPER	RAT	RETURN AIR TEMP. SEN
COFS	CONDENSATE OVERFLOW SWITCH	LA	LOW AMBIENT LOCKOUT	RDV	REHEAT DISCHARGE VALVE
COM	SIGNAL COMMON	LAR	LOW AMBIENT RELAY	RH	RELATIVE HUMIDITY
COMP	COMPRESSOR MOTOR	LAS	LOW AMBIENT SWITCH	RLV	REHEAT LIQUID VALVE
DDC	DIRECT DIGITAL CONTROL	LDR	COMPRESSOR LOADER	RNET	LOCAL ACCESS NETWORK
DFB	DEFROST BOARD	LEN	LOCAL EQUIPMENT NETWORK	RVS	REVERSING VALVE SOLENOID
DFT	DEFROST THERMOSTAT	LEO	LOSS OF CHARGE	SAT	SUPPLY AIR TEMP. SENSOR
EHR	ELECTRIC HEAT RELAY	LOC	LOSS OF CHARGE	SOP	SYSTEM DISCHARGE PRESSURE
ENTH	ENTHALPY	LOOP	CURRENT LOOP POWER	SPRH	SPACE RELATIVE HUMIDITY
ERV	ENERGY RECOVERY VENTILATOR	LPS	LOW PRESSURE SWITCH	SPT	SPACE TEMPERATURE SENSOR
ESL	ENTHALPY SENSOR - LOW	LS	LIMIT SWITCH	SPTO	SPACE TEMPERATURE OFFSET
ESL	ENTHALPY SENSOR - LOW	LSM	LIMIT SWITCH (MANUAL RESET)	SSP	SYSTEM SUCTION PRESSURE
FB	FUSE BLOCK	LTO	LOW TEMP LOCKOUT	SW	SWITCH
FIO	FACTORY INSTALLED OPTION	MBB	MAIN BASE BOARD	TB	TERMINAL BLOCK
FPT	FREEZE PROTECTION THERMOSTAT	MOV	METAL OXIDE VARISTOR	TDR	TIME DELAY RELAY
FST	FAN HOUSING TEMP SENSOR	MTR	MOTOR	TRAN	TRANSFORMER
FU	FUSE	OAO	OUTDOOR AIR QUALITY	UCB	UNIT CONTROL BOARD
G	THERMOSTAT FAN CALL	OAT	OUTDOOR AIR TEMP. SEN	W1	1st STAGE OF HEATING CALL
GR(GND)	GROUND	OAT	OUTDOOR AIR TEMP. SEN	W2	2nd STAGE OF HEATING CALL
HACR	HEATING, AIR-CONDITIONING, REFRIGERATION BREAKER	OFM	OUTDOOR FAN MOTOR	Y1	1st STAGE OF COOLING CALL
		OFO	OUTDOOR FAN ON RELAY	Y2	2nd STAGE OF COOLING CALL
		OL	OVERLOAD		

48TC003211 A

TYPICAL 50FCQ 04-07 POWER WIRING DIAGRAM, 208-230/3/60 UNIT WITH SYSTEMVU CONTROLLER

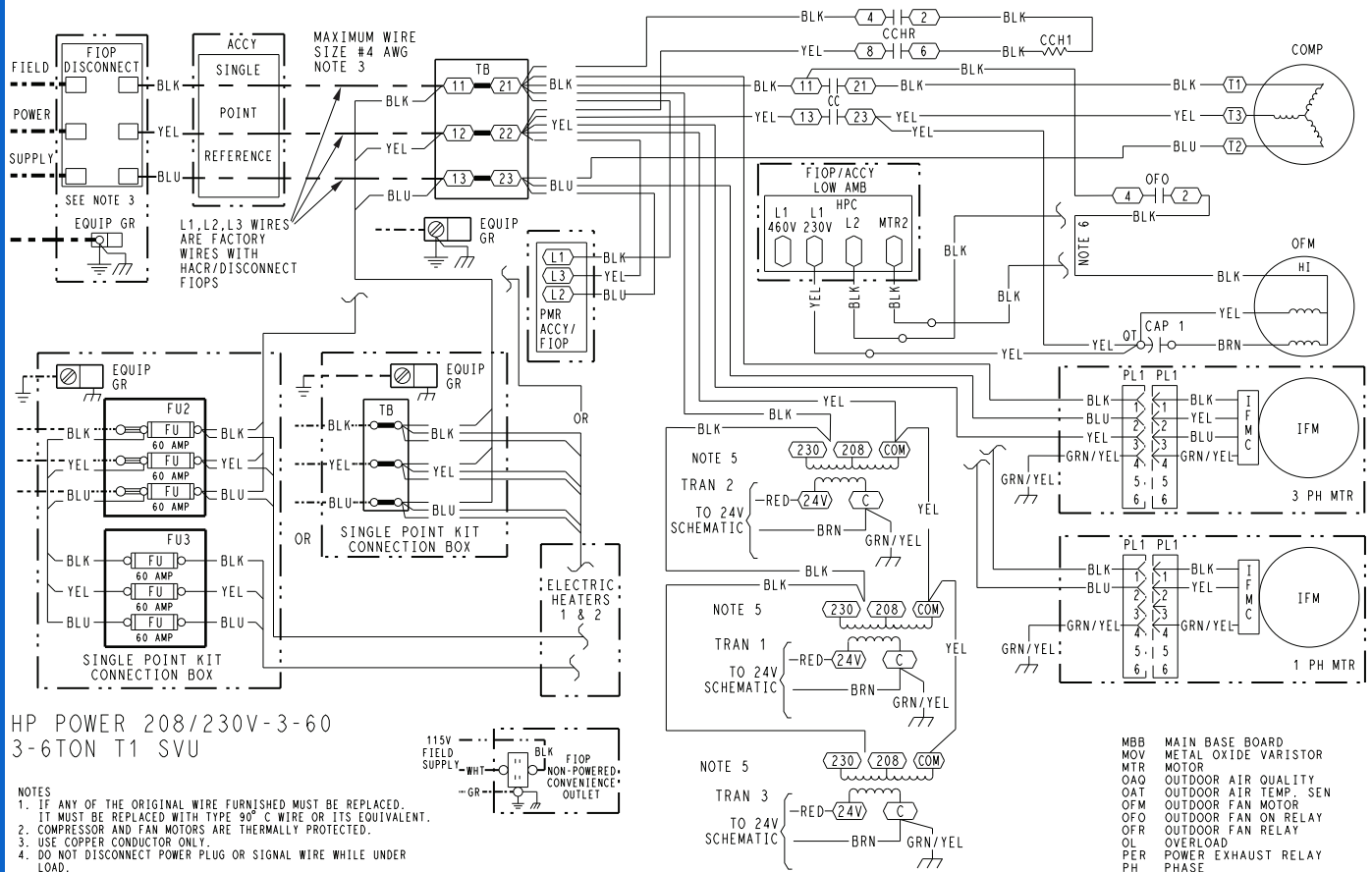

HP POWER 208/230V-3-60
3-6TON T1 SVU

- NOTES**
- IF ANY OF THE ORIGINAL WIRE FURNISHED MUST BE REPLACED, IT MUST BE REPLACED WITH TYPE 90° C WIRE OR ITS EQUIVALENT.
 - COMPRESSOR AND FAN MOTORS ARE THERMALLY PROTECTED.
 - USE COPPER CONDUCTOR ONLY.
 - DO NOT DISCONNECT POWER PLUG OR SIGNAL WIRE WHILE UNDER LOAD.
 - ON 208/230V UNITS, TRAN 1 IS WIRED FOR 230V. IF UNIT IS TO BE RUN WITH 208V POWER SUPPLY, DISCONNECT BLK WIRE FROM 230V TAP AND CONNECT TO 208V TAP.
 - THIS WIRE NOT USED WITH LOW AMBIENT FIOF/ACCY.

LEGEND

- MARKED WIRE
- TERMINAL (MARKED)
- TERMINAL (UNMARKED)
- TERMINAL BLOCK
- SPLICE
- SPLICE (MARKED)
- FACTORY WIRING
- FIELD CONTROL WIRING
- FIELD POWER WIRING
- CIRCUIT BOARD TRACE
- ACCESSORY OR OPTIONAL WIRING

- | | | | | | |
|-------|------------------------------|----------|--|------|--|
| ACCY | ACCESSORY | G | GROUND | HACR | HEATING, AIR-CONDITIONING, REFRIGERATION BREAKER |
| AWG | AMERICAN WIRE GAGE | GR(ND) | GROUND | HGRH | HOT GAS REHEAT |
| BAS | BUILDING AUTOMATION NETWORK | HACR | HEATING, AIR-CONDITIONING, REFRIGERATION BREAKER | HPC | HEAD PRESSURE CONTROL |
| CB | CIRCUIT BREAKER | HUM | HUMIDISTAT | HPS | HIGH PRESSURE SWITCH |
| CCH | CRANKCASE HEATER | IAQ | INDOOR AIR QUALITY SENSORS | IRH | INDOOR RELATIVE HUMIDITY |
| CCHTS | CRANKCASE HEATER TEMP SWITCH | IFM | INDOOR FAN MOTOR | JMP | JUMPER |
| CLO | COMPRESSOR LOCKOUT | IFMC | INDOOR FAN MOTOR CONTROL | LA | LOW AMBIENT LOCKOUT |
| CLV | COOLING LIQUID VALVE | IFO | INDOOR FAN ON SIGNAL | LAR | LOW AMBIENT RELAY |
| COPS | CONDENSATE OVERFLOW SWITCH | IRH | INDOOR RELATIVE HUMIDITY | LAS | LOW AMBIENT SWITCH |
| COM | SIGNAL COMMON | IRH | INDOOR RELATIVE HUMIDITY | LDR | COMPRESSOR LOADER |
| COMP | COMPRESSOR MOTOR | JMP | JUMPER | LEN | LOCAL EQUIPMENT NETWORK |
| DDC | DIRECT DIGITAL CONTROL | LOC | LOSS OF CHARGE | LPS | LOW PRESSURE SWITCH |
| DFB | DEFROST BOARD | LOOP PWR | CURRENT LOOP POWER | LS | LIMIT SWITCH |
| DFT | DEFROST THERMOSTAT | LPS | LOW PRESSURE SWITCH | LSM | LIMIT SWITCH (MANUAL RESET) |
| EHR | ELECTRIC HEAT RELAY | LTLO | LOW TEMP LOCKOUT | | |
| ENTH | ENTHALPY | | | | |
| ERV | ENERGY RECOVERY VENTILATOR | | | | |
| ESL | ENTHALPY SENSOR - LOW | | | | |
| FB | FUSE BLOCK | | | | |
| FIOF | FACTORY INSTALLED OPTION | | | | |
| FPT | FREEZE PROTECTION THERMOSTAT | | | | |
| FST | FAN HOUSING TEMP SENSOR | | | | |
| FU | FUSE | | | | |

- | | | | |
|------|---------------------------|------|---------------------------|
| MBB | MAIN BASE BOARD | PH | PHASE ASSEMBLY |
| MOV | METAL OXIDE VARISTOR | POT | POTENTIOMETER |
| MTR | MOTOR | PS | PHASE MONITOR RELAY |
| OAO | OUTDOOR AIR QUALITY | PS | PRESSURE SWITCH |
| OAT | OUTDOOR AIR TEMP. SEN | PMW | PULSE WIDTH MODULATION |
| OFM | OUTDOOR FAN MOTOR | QT | QUADRUPLE TERMINAL |
| OFO | OUTDOOR FAN ON RELAY | R | THERMOSTAT POWER |
| OFR | OUTDOOR FAN RELAY | RAT | RETURN AIR TEMP. SEN |
| OL | OVERLOAD | RDV | REHEAT DISCHARGE VALVE |
| PER | POWER EXHAUST RELAY | RH | RELATIVE HUMIDITY |
| PL | PLUG ASSEMBLY | RLV | REHEAT LIQUID VALVE |
| POT | POTENTIOMETER | RNET | LOCAL ACCESS NETWORK |
| PMR | PHASE MONITOR RELAY | RVS | REVERSING VALVE SOLENOID |
| PS | PRESSURE SWITCH | SAT | SUPPLY AIR TEMP. SENSOR |
| PMW | PULSE WIDTH MODULATION | SDP | SYSTEM DISCHARGE PRESSURE |
| QT | QUADRUPLE TERMINAL | SPRH | SPACE RELATIVE HUMIDITY |
| R | THERMOSTAT POWER | SPT | SPACE TEMPERATURE SENSOR |
| RAT | RETURN AIR TEMP. SEN | SPTO | SPACE TEMPERATURE OFFSET |
| RDV | REHEAT DISCHARGE VALVE | SSP | SYSTEM SUCTION PRESSURE |
| RH | RELATIVE HUMIDITY | SW | SWITCH |
| RLV | REHEAT LIQUID VALVE | TB | TERMINAL BLOCK |
| RNET | LOCAL ACCESS NETWORK | TDR | TIME DELAY RELAY |
| RVS | REVERSING VALVE SOLENOID | TRAN | TRANSFORMER |
| SAT | SUPPLY AIR TEMP. SENSOR | UCB | UNIT CONTROL BOARD |
| SDP | SYSTEM DISCHARGE PRESSURE | W1 | 1st STAGE OF HEATING CALL |
| SPRH | SPACE RELATIVE HUMIDITY | W2 | 2nd STAGE OF HEATING CALL |
| SPT | SPACE TEMPERATURE SENSOR | Y1 | 1st STAGE OF COOLING CALL |
| SPTO | SPACE TEMPERATURE OFFSET | Y2 | 2nd STAGE OF COOLING CALL |
| SSP | SYSTEM SUCTION PRESSURE | | |
| SW | SWITCH | | |
| TB | TERMINAL BLOCK | | |
| TDR | TIME DELAY RELAY | | |
| TRAN | TRANSFORMER | | |
| UCB | UNIT CONTROL BOARD | | |
| W1 | 1st STAGE OF HEATING CALL | | |
| W2 | 2nd STAGE OF HEATING CALL | | |
| Y1 | 1st STAGE OF COOLING CALL | | |
| Y2 | 2nd STAGE OF COOLING CALL | | |

48TC003212 A

TYPICAL 50FCQ 04-07 POWER WIRING DIAGRAM, 460-575/3/60 UNIT WITH SYSTEMVU CONTROLLER

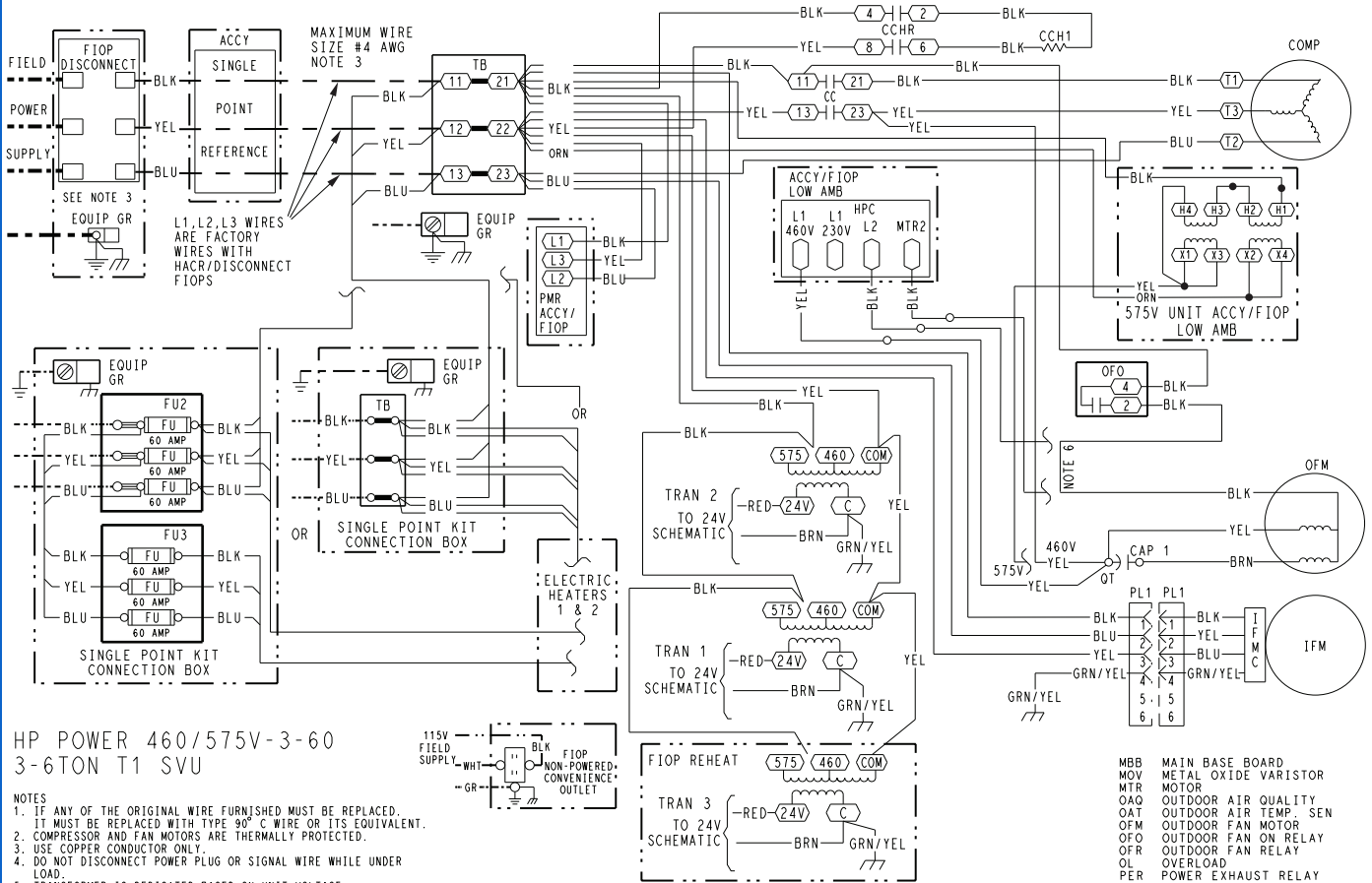

HP POWER 460/575V-3-60
3-6TON T1 SVU

- NOTES**
1. IF ANY OF THE ORIGINAL WIRE FURNISHED MUST BE REPLACED, IT MUST BE REPLACED WITH TYPE 90° C WIRE OR ITS EQUIVALENT.
 2. COMPRESSOR AND FAN MOTORS ARE THERMALLY PROTECTED.
 3. USE COPPER CONDUCTOR ONLY.
 4. DO NOT DISCONNECT POWER PLUG OR SIGNAL WIRE WHILE UNDER LOAD.
 5. TRANSFORMER IS DEDICATED BASED ON UNIT VOLTAGE. TAPS ONLY SHOWN TO SIMPLIFY SCHEMATIC.
 6. THIS WIRE NOT USED WITH LOW AMBIENT FIOP/ACCY.

LEGEND

- (X) MARKED WIRE
- (X) TERMINAL (MARKED)
- () TERMINAL (UNMARKED)
- (X) TERMINAL BLOCK
- SPLICE
- SPLICE (MARKED)
- FACTORY WIRING
- - - FIELD CONTROL WIRING
- - - FIELD POWER WIRING
- - - CIRCUIT BOARD TRACE
- - - ACCESSORY OR OPTIONAL WIRING

- | | | | |
|-------|------------------------------|---------|--|
| ACCY | ACCESSORY | G | THERMOSTAT FAN CALL |
| AWG | AMERICAN WIRE GAGE | GR(GND) | GROUND |
| BAS | BUILDING AUTOMATION NETWORK | HACR | HEATING, AIR-CONDITIONING, REFRIGERATION BREAKER |
| CC | COMMON | HR | HEATER RELAY |
| CAP | CAPACITOR | HGRH | HOT GAS REHEAT |
| CB | CIRCUIT BREAKER | HPC | HEAD PRESSURE CONTROL |
| CCH | CRANKCASE HEATER | HPS | HIGH PRESSURE SWITCH |
| CCHR | CRANKCASE HEATER RELAY | HUM | HUMIDISTAT |
| CCHTS | CRANKCASE HEATER TEMP SWITCH | IAQ | INDOOR AIR QUALITY SENSORS |
| CLO | COMPRESSOR LOCKOUT | IFM | INDOOR FAN MOTOR |
| CLV | COOLING LIQUID VALVE | IFMC | INDOOR FAN MOTOR CONTROL |
| CFS | CONDENSATE OVERFLOW SWITCH | IFO | INDOOR FAN ON SIGNAL |
| COM | SIGNAL COMMON | IRH | INDOOR RELATIVE HUMIDITY |
| COMP | COMPRESSOR MOTOR | JMP | JUMPER |
| DDC | DIRECT DIGITAL CONTROL | L | LINE |
| DFB | DEFROST BOARD | LA | LOW AMBIENT LOCKOUT |
| DFT | DEFROST THERMOSTAT | LAR | LOW AMBIENT RELAY |
| EHR | ELECTRIC HEAT RELAY | LAS | LOW AMBIENT SWITCH |
| ENTH | ENTHALPY | LDR | COMPRESSOR LOADER |
| ERV | ENERGY RECOVERY VENTILATOR | LEN | LOCAL EQUIPMENT NETWORK |
| ESL | ENTHALPY SENSOR - LOW | LOC | LOSS OF CHARGE |
| FB | FUSE BLOCK | LOP | LOW PRESSURE |
| FIOP | FACTORY INSTALLED OPTION | LPS | LOW PRESSURE SWITCH |
| FPT | FREEZE PROTECTION THERMOSTAT | LS | LIMIT SWITCH |
| FST | FAN HOUSING TEMP SENSOR | LSM | LIMIT SWITCH (MANUAL RESET) |
| FU | FUSE | LTLO | LOW TEMP LOCKOUT |

48TC003213 A

General

The sequence below describes the sequence of operation for an electro-mechanical unit with and without a factory-installed EconoMi\$er® IV (W7212 controller) and X (W7220 controller). For information regarding a direct digital controller, see the start-up, operations, and troubleshooting manual for the applicable controller.

Electro-Mechanical Units with No Economizer

Cooling (single stage units)

When the thermostat calls for cooling, terminals G and Y1 are energized. The indoor fan will run at the user set fan speed and the compressor contactor (CC) is energized causing the compressor and outdoor fan to run.

When the thermostat removes the call for Y1, the compressor contactor will de-energize shutting down the compressor and the outdoor fan. When the thermostat removes the call for G, the indoor fan will turn off after the specific unit fan off delay.

Cooling (two stage units)

When the thermostat calls for cooling, terminals G and Y1 are energized. The indoor fan will run at the low fan speed and the compressor contactor (CC) is energized causing the compressor and outdoor fan to run. The low indoor fan speed is 66% of the user set fan speed and the compressor will run at partial capacity.

If additional cooling is needed, the thermostat will add the call for Y2. This will increase the indoor fan speed to the user set fan speed and energize the compressor loader for full compressor capacity. The outdoor fan is the same speed for Y1 and Y2.

When the thermostat removes the call for Y2 but leaves the Y1, the indoor fan will reduce speed to 66% of the user set fan speed, the compressor loader will turn off, and the outdoor fan will remain on. When the thermostat removes the call for Y1 the compressor contactor will de-energize shutting down the compressor and the outdoor fan. When the thermostat removes the call for G, the indoor fan will turn off after the specific unit fan off delay.

NOTE: Per ASHRAE 90.1-2016 and IECC-2018 standards, during the first stage of cooling operation the Unit Control Board (UCB) will adjust the fan motor speed to provide 66% of the total cfm established for the unit.

Defrost

When the temperature of the outdoor coil drops below 28°F (-2°C) as sensed by the defrost thermostat (DFT2) and the defrost timer is at the end of a timed period (adjustable at 30, 60, 90 or 120 minutes), reversing valve solenoids (RVS1 and RVS2) are energized and the OFC is de-energized. This switches the position of the reversing valves and shuts off the outdoor fan. The electric heaters (if installed) will be energized.

Heating, unit with economizer

When the room temperature calls for heat through terminal W1, the indoor (evaporator) fan contactor (IFC) and heater contactor no. 1 (HC1) are energized and the reversing valve(s) de-energize and switches position. On units equipped for 2 stages of heat, when additional heat is needed, heater contactor no. 2 is energized through W2. The economizer damper moves to the minimum position. When the thermostat is satisfied, the damper moves to the fully closed position.

Heating, unit without economizer

Upon a request for heating from the space thermostat, terminal W1 will be energized with 24V. The IFC, outdoor fan contactor (OFC), C1, and C2 will be energized. The indoor fan, outdoor fans, and compressor no. 1, and compressor no. 2 are energized and reversing valves are de-energized and switch position.

If the space temperature continues to fall while W1 is energized, W2 will be energized with 24V, and the heater contactor(s) (HC) will be energized, which will energize the electric heater(s).

When the space thermostat is satisfied, W2 will be de-energized first, and the electric heater(s) will be de-energized. Upon a further rise in space temperature, W1 will be de-energized.

IMPORTANT: The thermostat must be configured for Electric Heat so it will energize G with the W1 call.

Electro-mechanical Units with Factory-Installed EconoMi\$er

When free cooling is not available, the compressors will be controlled by the zone thermostat. When free cooling is available, the outdoor-air damper is modulated by the EconoMi\$er IV and X control to provide a 50°F (10°C) to 55°F (13°C) mixed-air temperature into the zone. As the mixed air temperature fluctuates above 55°F (13°C) or below 50°F (10°C) dampers will be modulated (open or close) to bring the mixed-air temperature back within control. If mechanical cooling is utilized with free cooling, the outdoor-air damper will maintain its current position at the time the compressor is started. If the increase in cooling capacity causes the mixed-air temperature to drop below 45°F (7°C), then the outdoor-air damper position will be decreased to the minimum position. If the mixed-air temperature continues to fall, the outdoor-air damper will close. Control returns to normal once the mixed-air temperature rises above 48°F (9°C). The power exhaust fans will be energized and de-energized, if installed, as the outdoor-air damper opens and closes.

If field-installed accessory CO₂ sensors are connected to the EconoMi\$er IV and X control, a demand controlled ventilation strategy will begin to operate. As the CO₂ level in the zone increases above the CO₂ set-point, the minimum position of the damper will be increased proportionally. As the CO₂ level decreases because of the increase in fresh air, the outdoor-air damper will be proportionally closed. For EconoMi\$er IV and X operation, there must be a thermostat call for the fan (G). If the unit is occupied and the fan is on, the damper will operate at minimum position. Otherwise, the damper will be closed.

When the EconoMi\$er IV and X control is in the occupied mode and a call for cooling exists (Y1 on the thermostat), the control will first check for indoor fan operation. If the fan is not on, then cooling will not be activated. If the fan is on, then the control will open the EconoMi\$er IV and X damper to the minimum position.

On the initial power to the EconoMi\$er® IV and X control, it will take the damper up to 2¹/₂ minutes before it begins to position itself. After the initial power-up, further changes in damper position can take up to 30 seconds to initiate. Damper movement from full closed to full open (or vice versa) will take between 1¹/₂ and 2¹/₂ minutes. If free cooling can be used as determined from the appropriate changeover command (switch, dry bulb, enthalpy curve,

differential dry bulb, or differential enthalpy), then the control will modulate the dampers open to maintain the mixed-air temperature set-point at 50°F (10°C) to 55°F (13°C). If there is a further demand for cooling (cooling second stage — Y2 is energized), then the control will bring on compressor stage 1 to maintain the mixed-air temperature set-point. The EconoMi\$er IV and X damper will be open at maximum position.

2-Speed Note: The EconoMi\$er IV and X controller will adjust the damper position as the Indoor Fan Speed changes, per its configured values.

Heating

The sequence of operation for the heating is the same as an electro-mechanical unit with no economizer. The only difference is how the economizer acts. The economizer will stay at the Economizer Minimum Position while the evaporator

fan is operating. The outdoor-air damper is closed when the indoor fan is not operating. Refer to Service and Maintenance Manual for further details.

RTU Open controller (factory option)

For details on operating 50FCQ units equipped with the factory-installed RTU Open controller option, refer to Factory Installed RTU Open Multi-Protocol Controller Controls, Start-Up, Operation and Troubleshooting manual.

SystemVu™ controller (factory option)

For details on operating 50FCQ units equipped with the factory-installed SystemVu controller option, refer to FCQ/GCQ Series Single Package Rooftop Units with SystemVu Controller Controls, Start-Up, Operation and Troubleshooting manual.

Minimum operating ambient temperature (cooling)

In mechanical cooling mode, your Carrier rooftop unit can safely operate down to an outdoor ambient temperature of 40°F (4°C). It is possible to provide cooling at lower outdoor ambient temperatures by using less outside air, economizers, and/or accessory low ambient kits.

Maximum operating ambient temperature (cooling)

The maximum operating ambient temperature for cooling mode is 115°F (46°C). While cooling operation above 115°F (46°C) may be possible, it could cause either a reduction in performance, reliability, or a protective action by the unit's internal safety devices.

Multiple motor and drive packages

Some applications need larger horsepower motors, some need more airflow, and some need both. Regardless of the case, your Carrier expert has a factory installed combination to meet your application. A wide selection of motors are available, factory installed, to handle nearly any application.

Minimum and maximum airflow (heating and cooling)

To maintain safe and reliable operation of your rooftop, operate within the heating airflow limits during heating mode and cooling airflow limits during cooling mode. Operating above the max may cause blow-off, undesired airflow noise, or airflow related problems with the rooftop unit. Operating below the min may cause problems with coil freeze-up and unsafe heating operation. Heating and cooling limitations differ when evaluating operating CFM, the minimum value is the HIGHER of the cooling and heating minimum CFM values published on page 6 and the maximum value is the LOWER of the cooling and heating minimum values published on page 6.

Heating-to-cooling changeover

Your unit will automatically change from heating to cooling mode when using a thermostat with an auto-changeover feature.

Airflow

All units are draw-through in cooling mode and blow-through in heating mode.

Outdoor air application strategies

Economizers reduce operating expenses and compressor run time by providing a free source of cooling and a means of ventilation to match application changing needs. In fact,

they should be considered for most applications. Also, consider the various economizer control methods and their benefits, as well as sensors required to accomplish your application goals. Please contact your local Carrier representative for assistance.

Motor limits, break horsepower (BHP)

Due to internal design of Carrier units, the air path, and specially designed motors, the full horsepower (maximum continuous BHP) band, as listed in the Fan Performance tables, can be used with the utmost confidence. There is no need for extra safety factors, as Carrier motors are designed and rigorously tested to use the entire, listed BHP range without either nuisance tripping or premature motor failure.

Sizing a rooftop

Bigger is not necessarily better. While an air conditioner needs to have enough capacity to meet the design loads, it does not need excess capacity. In fact, excess capacity typically results in very poor part load performance and humidity control.

Using higher design temperatures than ASHRAE recommends for your location, adding "safety factors" to the calculated load, are all signs of oversizing air conditioners. Oversizing the air conditioner leads to poor humidity control, reduced efficiency, higher utility bills, larger indoor temperature swings, excessive noise, and increased wear and tear on the air conditioner.

Rather than oversizing an air conditioner, engineers should "right-size" or even slightly "under-size" air conditioners. Correctly sizing an air conditioner controls humidity better; promotes efficiency; reduces utility bills; extends equipment life, and maintains even, comfortable temperatures. Please contact your local Carrier representative for assistance.

Low ambient applications

The optional Carrier economizer can adequately cool your space by bringing in fresh, cool outside air. In fact, when so equipped, accessory low-ambient kit may not be necessary. In low ambient conditions, unless the outdoor air is excessively humid or contaminated, economizer-based "free cooling" is the preferred less costly and energy conscious method. In low ambient applications where outside air might not be desired (such as contaminated or excessively humid outdoor environments), your Carrier rooftop can operate to ambient temperatures down to -20°F (-29°C) using the recommended accessory low ambient controller.

This specification is in the “Masterformat” as published by the Construction Specification Institute. Please feel free to copy this specification directly into your building spec.



Rooftop Packaged Heat Pump

HVAC Guide Specifications

Size Range: **3 to 6 Nominal Tons**

Carrier Model Number: **50FCQ04-07**

Part 1 — (23 06 80) Schedules for Decentralized HVAC Equipment

1.01 (23 06 80.13) Decentralized Unitary HVAC Equipment Schedule:

- A. (23 06 80.13.A.) Rooftop unit (RTU) schedule:
 - 1. Schedule is per the project specification requirements.

Part 2 — (23 07 16) HVAC equipment insulation

2.01 (23 07 16.13) Decentralized, Rooftop Units:

- A. (23 07 16.13.A.) Evaporator fan compartment:
 - 1. Interior cabinet surfaces shall be insulated with a minimum 1/2-in. thick, minimum 1 1/2-lb density, flexible fiberglass insulation bonded with a phenolic binder, neoprene coated on the air side.
 - 2. Insulation and adhesive shall meet NFPA 90A requirements for flame spread and smoke generation.
- B. (23 07 16.13.B.) Electric Heat Compartment:
 - 1. Aluminum foil-faced fiberglass insulation shall be used.
 - 2. Insulation and adhesive shall meet NFPA 90A requirements for flame spread and smoke generation.

Part 3 — (23 09 13) Instrumentation and control devices for HVAC

3.01 (23 09 13.13) Sensors and Transmitters:

- A. (23 09 13.13.A.) Thermostats:
 - 1. Thermostat must
 - a. have capability to energize 2 different stages of cooling, and 2 different stages of heating. (07 models have 2-stage cooling capabilities).
 - b. be heat pump design and include capability for occupancy scheduling.

Part 4 — (23 09 23) Direct Digital Control system for HVAC

4.01 (23 09 23.13) Decentralized, Rooftop Units:

- A. (23 09 23.13.A.) SystemVu™ intelligent integrated Direct Digital Control (DDC) shall provide:
 - 1. Integrated unit operation for comfort cooling, heating ventilation as well as all monitoring, recording and reporting capabilities. Controller

shall also provide diagnostics and alarms of abnormal unit operation through the controller. Controller shall have an intuitive user display and be able to be used in a standalone operation or via building automation system (BAS).

- 2. Quick Unit Status LEDs of: Run – meaning all systems are go, ALERT – that indicates there is currently a non-critical issue with the unit, like filters need to be replaced and FAULT – that indicates the unit has a critical issue and will possibly shut down.
- 3. Six large navigation keys for easy access. Navigation keys shall consist of: TEST, BACK, ENTER, and MENU along with UP and DOWN arrows.
- 4. Full back lit user display with 4 line by 30 character text capabilities. Display menu shall be designed to provide guided major menus and sub menus main menus provided below:
 - a. Shutdown Unit
 - b. Run Status
 - c. Settings
 - d. Alerts/Faults
 - e. Service
 - f. Inputs
 - g. Outputs
 - h. USB
- 5. The capability for standalone operation with conventional thermostat/sensor or use with building automation systems (BAS) of Carrier i-Vu®, BACnet and Carrier Comfort Network® (CCN) systems. No special modules or boards are required for these capabilities. Has the capability to work with Equipment Touch™ and System Touch™ devices and ZS Sensors.
- 6. The ability to read refrigerant pressures at display or via BAS network of; Discharge Pressure and Suction Pressure. The need for traditional refrigerant gages is not required.
- 7. USB Data Port for flash drive interaction. This will allow the transfer of data for uploads, downloads, perform software upgrades, back-up and restore data and file transfer data such as component number of starts and run hours.
- 8. Reverse Rotation Protection of compressors if field three phase wiring is misapplied.
- 9. Provide Service Capabilities of:
 - a. Auto run test
 - b. Manual run test
 - c. Component run hours and starts
 - d. Commissioning reports
 - e. Data logging
 - f. Alarm history

10. Economizer control and diagnostics. Set up economizer operation, receive feedback from actuator. Also meets the most recent California Title 24, ASHRAE 90.1 and IECC Fault Detection and Diagnostic (FDD) requirements.
 11. Unit cooling operation down to 40°F (4°C).
 12. Controller shall have easy access connections around the controller perimeter area and consist of Mate-N-Lok, terminal block and RJ style modular jack connections.
 13. 365 day real time clock, 20 holiday schedules along with occupied and unoccupied scheduling.
 14. Auto-Recognition for easy installation and commissioning of devices like economizers, space sensors, etc.
 15. A 5°F temperature difference between cooling and heating set points to meet the latest ASHRAE 90.1 Energy Standard.
 16. Contain return air sensor, supply air sensor and outdoor air sensor to help monitor and provide data for the unit comfort operation, diagnostic and alarms.
 17. Use of Carrier's field accessory hand-held Navigator™ display, Equipment Touch and System Touch devices.
 18. Supply Air Tempering control operates the electric heat to maintain a minimum supply air temperature during conditions where very cold outdoor air causes the supply air temperature to fall below the configured Supply Air Tempering Setpoint. This occurs during periods where DCV is active and increasing the amount of outdoor air or in cases where the system is operating at very low airflow and the calculated economizer position has increased to maintain a constant ventilation rate.
 19. Demand limiting in SystemVu™ is achieved through set point expansion. The systems heating and cooling set points are expanded in steps or levels. The degree to which the set points may be expanded is defined by the 6 demand level offsets and the 2 commanded demand limit levels.
 20. 3-year limited part warranty.
- B. (23 09 23.13.B.) RTU Open Protocol, Direct Digital Controller:
1. Shall be ASHRAE 62 compliant.
 2. Shall accept 18 - 30VAC, 50 - 60Hz, and consumer 15VA or less power.
 3. Shall have an operating temperature range from -40°F (-40°C) to 130°F (54°C), 10% to 90% RH (non-condensing).
 4. Shall include built-in protocol for BACnet¹ (MS/TP and PTP modes), Modbus² (RTU and ASCII), Johnson N2 and LonWorks³. LonWorks Echelon processor required for all Lon applications shall be contained in separate communication board.
5. Shall allow access of up to 62 network variables (SNVT). Shall be compatible with all open controllers.
 6. Baud rate controller shall be selectable using a dipswitch.
 7. Shall have an LED display independently showing the status of serial communication, running, errors, power, all digital outputs, and all analog inputs.
 8. Shall accept the following inputs: space temperature, setpoint adjustment, outdoor air temperature, indoor air quality, outdoor air quality, compressor lock-out, fire shutdown, enthalpy switch, and fan status/filter status/humidity/remote occupancy.
 9. Shall provide the following outputs: economizer, fan, cooling stage 1, cooling stage 2, heat stage 1, heat stage 2, exhaust, reversing valve/high fan speed.
 10. Shall have built-in surge protection circuitry through solid-state polyswitches. Polyswitches shall be used on incoming power and network connections. Polyswitches will return to normal when the "trip" condition clears.
 11. Shall have a battery back-up capable of a minimum of 10,000 hours of data and time clock retention during power outages.
 12. Shall have built-in support for Carrier technician tool.
 13. Shall include an RS-485 protocol communication port, an access port for connection of either a computer or a Carrier technician tool, an RS-485 port for network communication to intelligent space sensors and displays, and a port to connect an optional LonWorks communications card.
 14. Software upgrades will be accomplished by either local or remote download. No software upgrades through chip replacements are allowed.

Part 5 — (23 09 33) Electric and Electronic Control System for HVAC

5.01 (23 09 33.13) Decentralized, Rooftop Units:

A. (23 09 33.13.A.) General:

1. Shall be complete with self-contained low-voltage control circuit protected by a resettable circuit breaker on the 24-v transformer side. Transformer shall have 75VA capability.
2. Shall utilize color-coded wiring.
3. Shall include a Unit Control Board to conveniently and safely provide connection points for

1. BACnet is a trademark of ASHRAE.

2. Modbus is a registered trademark of Schneider Electric.

3. LonWorks is a registered trademark of Echelon Corporation.

vital control functions such as: smoke detectors, phase monitor, economizer, thermostat, DDC control options, and low and high pressure switches. Controller shall also provide an intuitive means to adjust the indoor fan speed through a simple switch and pot adjustment design.

4. Unit shall include a minimum of one 8-pin screw terminal connection board for connection of control wiring.
 5. Shall include integrated defrost system to prevent excessive frost accumulation during heating duty, and shall be controlled as follows:
 - a. Defrost shall be initiated on the basis of time and coil temperature.
 - b. A 30, 60, 90, 120 minute timer shall activate the defrost cycle only if the coil temperature is low enough to indicate a heavy frost condition.
 - c. Defrost cycle shall terminate when defrost thermostat is satisfied and shall have a positive termination time of 10 minutes.
 6. Defrost system shall also include:
 - a. Defrost Cycle Indicator LED.
 - b. Dip switch selectable defrost time between 30, 60, 90 and 120 minutes. Factory set at 30 minutes.
 - c. Molded plug connection to ensure proper connection.
- B. (23 09 33.13.B.) Safeties:
1. Compressor over-temperature, over-current. High internal pressure differential.
 2. Low pressure switch.
 - a. Low pressure switch shall use different color wire than the high pressure switch. The purpose is to assist the installer and service technician to correctly wire and or troubleshoot the rooftop unit.
 3. High pressure switch.
 - a. High pressure switch shall use different color wire than the low pressure switch. The purpose is to assist the installer and service technician to correctly wire and or troubleshoot the rooftop unit.
 4. Automatic reset, motor thermal overload protector.

Part 6 — (23 09 93) Sequence of Operations for HVAC Controls

- 6.01 (23 09 93.13) Decentralized, Rooftop Units:
- A. (23 09 93.13.A.) INSERT SEQUENCE OF OPERATION

Part 7 — (23 40 13) Panel Air Filters

- 7.01 (23 40 13.13) Decentralized, Rooftop Units:
- A. (23 40 13.13.A.) Standard filter section:
 1. Shall consist of factory installed, low velocity, disposable 2-in. thick fiberglass filters of commercially available sizes.

2. Unit shall use only one filter size. Multiple sizes are not acceptable.
3. Filters shall be accessible through an access panel with “no-tool” removal as described in the unit cabinet section of this specification (23 81 19.13.G).

Part 8 — (23 81 19) Self-Contained Air Conditioners

- 8.01 (23 81 19.13) Small-Capacity Self-Contained Air Conditioners (50FCQ 04-07):
- A. (23 81 19.13.A.) General:
 1. Outdoor, rooftop mounted, electrically controlled, heating and cooling unit utilizing a fully hermetic scroll compressor(s) for cooling duty and heat pump heating duty.
 2. Factory assembled, single-piece heating and cooling rooftop unit. Contained within the unit enclosure shall be all factory wiring, piping, controls, and special features required prior to field start-up.
 3. Unit shall use Puron® (R-410A) refrigerant.
 4. Unit shall be installed in accordance with the manufacturer’s instructions.
 5. Unit must be selected and installed in compliance with local, state, and federal codes.
 - B. (23 81 19.13.B.) Quality Assurance:
 1. Unit meets ASHRAE 90.1 minimum efficiency requirements.
 2. Unit shall be rated in accordance with AHRI Standards 210/240 (04-06 sizes) or 340/360 (07 size).
 3. Unit shall be designed to conform to ASHRAE 15.
 4. Unit shall be UL-tested and certified in accordance with ANSI Z21.47 Standards and UL-listed and certified under Canadian standards as a total package for safety requirements.
 5. Insulation and adhesive shall meet NFPA 90A requirements for flame spread and smoke generation.
 6. Unit casing shall be capable of withstanding 500 hour salt spray exposure per ASTM B117 (scribed specimen).
 7. Unit shall be designed in accordance with ISO 9001, and shall be manufactured in a facility registered by ISO 9001:2015.
 8. Roof curb shall be designed to conform to NRCA Standards.
 9. Unit shall be subjected to a completely automated run test on the assembly line. The data for each unit will be stored at the factory, and must be available upon request.
 10. Unit shall be designed in accordance with UL Standard 1995, including tested to withstand rain.

11. Unit shall be constructed to prevent intrusion of snow and tested to prevent snow intrusion into the control box up to 40 mph.
12. Unit shake tested to assurance level 1, ASTM D4169 to ensure shipping reliability.
- C. (23 81 19.13.C.) Delivery, Storage, and Handling:
 1. Unit shall be stored and handled per manufacturer's recommendations.
 2. Lifted by crane requires either shipping top panel or spreader bars.
 3. Unit shall only be stored or positioned in the upright position.
- D. (23 81 19.13.D.) Project Conditions:
 1. As specified in the contract.
- E. (23 81 19.13.E.) Operating Characteristics:
 1. Unit shall be capable of starting and running at 115°F (46°C) ambient outdoor temperature, meeting maximum load criteria of AHRI Standard 210/240 or 340/360 at ±10% voltage.
 2. Compressor with standard controls shall be capable of operation down to 40°F (4°C), ambient outdoor temperatures. Accessory winter start kit is necessary if mechanically cooling at ambient temperatures down to 25°F (-4°C).
 3. Unit shall discharge supply air vertically or horizontally as shown on contract drawings.
 4. Unit shall be factory configured for vertical supply and return configurations.
 5. Unit shall be field convertible from vertical to horizontal airflow on all models. No special kit required.
 6. Unit shall be capable of mixed operation: vertical supply with horizontal return or horizontal supply with vertical return.
- F. (23 81 19.13.F.) Electrical Requirements:
 1. Main power supply voltage, phase, and frequency must match those required by the manufacturer.
- G. (23 81 19.13.G.) Unit Cabinet:
 1. Unit cabinet shall be constructed of galvanized steel, and shall be bonderized and coated with a prepainted baked enamel finish on all externally exposed surfaces.
 2. Unit cabinet exterior paint shall be: film thickness, (dry) 0.003-in. minimum, gloss (per ASTM D523, 60°F/16°C): 60, Hardness: H-2H Pencil hardness.
 3. Evaporator fan compartment interior cabinet insulation shall conform to AHRI Standards 210/240 and or 340/360 minimum exterior sweat criteria. Interior surfaces shall be insulated with a minimum 1/2-in. thick, 1 lb density, flexible fiberglass insulation, neoprene coated on the air side. Aluminum foil-faced fiberglass insulation shall be used in the heat compartment.
4. Base of unit shall have a minimum of four locations for thru-the-base gas and electrical connections (factory-installed or field-installed), standard.
5. Base Rail:
 - a. Unit shall have base rails on a minimum of 2 sides.
 - b. Holes shall be provided in the base rails for rigging shackles to facilitate maneuvering and overhead rigging.
 - c. Holes shall be provided in the base rail for moving the rooftop by fork truck.
 - d. Base rail shall be a minimum of 16 gage thickness.
6. Condensate pan and connections:
 - a. Shall be a sloped condensate drain pan made of a corrosion resistant material.
 - b. Shall comply with ASHRAE Standard 62.
 - c. Shall use a 3/4-in. 14 NPT drain connection, possible either through the bottom or side of the drain pan. Connection shall be made per manufacturer's recommendations.
7. Top panel:
 - a. Shall be a single piece top panel on all sizes.
8. Electrical Connections:
 - a. All unit power wiring shall enter unit cabinet at a single, factory prepared, knockout location.
 - b. Thru-the-base capability.
 - 1.) Standard unit shall have a thru-the-base electrical location(s) using a raised, embossed portion of the unit basepan.
 - 2.) Optional, factory approved, water-tight connection method must be used for thru-the-base electrical connections.
 - 3.) No basepan penetration, other than those authorized by the manufacturer, is permitted.
9. Component access panels (standard):
 - a. Cabinet panels shall be easily removable for servicing.
 - b. Unit shall have one factory installed, tool-less, removable, filter access panel.
 - c. Panels covering control box, indoor fan, indoor fan motor, gas components (where applicable), and compressors shall have molded composite handles.
 - d. Handles shall be UV modified, composite. They shall be permanently attached, and recessed into the panel.
 - e. Screws on the vertical portion of all removable access panel shall engage into heat resistant, molded composite collars.
 - f. Collars shall be removable and easily replaceable using manufacturer recommended parts.

H. (23 81 19.13.H.) Coils:

1. Standard industry proven Aluminum Fin-Copper Tube Coils:
 - a. Standard evaporator and condenser coils shall have aluminum lanced plate fins mechanically bonded to seamless internally grooved copper tubes with all joints brazed.
 - b. Evaporator coils shall be leak tested to 150 psig, pressure tested to 450 psig, and qualified to UL 1995 burst test at 1775 psig.
 - c. Condenser coils shall be leak tested to 150 psig, pressure tested to 650 psig, and qualified to UL 1995 burst test at 1980 psig.
2. Optional Pre-coated aluminum-fin condenser coils (3 Phase Models Only):
 - a. Shall have a durable epoxy-phenolic coating to provide protection in mildly corrosive coastal environments.
 - b. Coating shall be applied to the aluminum fin stock prior to the fin stamping process to create an inert barrier between the aluminum fin and copper tube.
 - c. Epoxy-phenolic barrier shall minimize galvanic action between dissimilar metals.
 - d. Corrosion durability of fin stock shall be confirmed through testing to be no less than 1000 hours salt spray per ASTM B117-90.
 - e. Corrosion durability of fin stock shall be confirmed through testing to have no visible corrosion after 48 hour immersion in a room temperature solution of 5% salt, 1% acetic acid.
 - f. Fin stock coating shall pass 2000 hours of the following: one week exposure in the prohesion chamber followed by one week of accelerated ultraviolet light testing. Prohesion chamber: the solution shall contain 3.5% sodium chloride and 0.35% ammonium sulfate. The exposure cycle is one hour of salt fog application at ambient followed by one hour drying at 95°F (35°C).
3. Optional Copper-fin evaporator and condenser coils (3 Phase Models Only):
 - a. Shall be constructed of copper fins mechanically bonded to copper tubes and copper tube sheets.
 - b. Galvanized steel tube sheets shall not be acceptable.
 - c. A polymer strip shall prevent coil assembly from contacting the sheet metal coil pan to minimize potential for galvanic corrosion between coil and pan.
4. Optional E-coated aluminum-fin evaporator and condenser coils (3 Phase Models Only):
 - a. Shall have a flexible epoxy polymer coating uniformly applied to all coil surface areas without material bridging between fins.

- b. Coating process shall ensure complete coil encapsulation of tubes, fins and headers.
- c. Color shall be high gloss black with gloss per ASTM D523-89.
- d. Uniform dry film thickness from 0.8 to 1.2 mil on all surface areas including fin edges.
- e. Superior hardness characteristics of 2H per ASTM D3363-92A and cross-hatch adhesion of 4B-5B per ASTM D3359-93.
- f. Impact resistance shall be up to 160 in.-lb (ASTM D2794-93).
- g. Humidity and water immersion resistance shall be up to minimum 1000 and 250 hours respectively (ASTM D2247-92 and ASTM D870-92).
- h. Corrosion durability shall be confirmed through testing to be no less than 1000 hours salt spray per ASTM B117-90.

I. (23 81 19.13.I.) Refrigerant Components:

1. Refrigerant circuit shall include the following control, safety, and maintenance features:
 - a. Fixed cooling orifice metering system on 04-06 models and TXV on 07 size models shall include a multiple feed distribution system that optimizes coil performance. Fixed heating orifice metering system on all 04-07 models shall include a multiple feed distribution system that optimizes coil performance.
 - b. Refrigerant filter drier - Solid core design.
 - c. Service gage connections on suction and discharge lines.
 - d. Pressure gage access through a specially designed access port in the top panel of the unit.
 - e. Suction line accumulator to provide protection in all operating modes from cooling, heating and reverse cycle switching.
2. There shall be gage line access port in the skin of the rooftop, covered by a black, removable plug.
 - a. The plug shall be easy to remove and replace.
 - b. When the plug is removed, the gage access port shall enable maintenance personnel to route their pressure gage lines.
 - c. This gage access port shall facilitate correct and accurate condenser pressure readings by enabling the reading with the compressor access panel on.
 - d. The plug shall be made of a leak proof, UV-resistant, composite material.
3. Compressors:
 - a. Unit shall use fully hermetic, heat pump duty scroll compressor on single circuit independent refrigeration circuit.

- b. Compressor motors shall be cooled by refrigerant gas passing through motor windings.
 - c. Compressors shall be internally protected from high discharge temperature conditions.
 - d. Compressors shall be protected from an over-temperature and over-ampereage conditions by an internal, motor overload device.
 - e. Compressor shall be factory mounted on rubber grommets.
 - f. Compressor motors shall have internal line break thermal, current overload and high pressure differential protection.
 - g. Crankcase heaters shall not be required for normal operating range, unless required by compressor manufacturer due to refrigerant charge limits.
 - h. Compressor on 04-06 models shall be of a single stage cooling capacity design and 07 models shall be a two stage cooling capacity design.
- J. (23 81 19.13.J.) Filter Section:
- 1. Filters access is specified in the unit cabinet section of this specification.
 - 2. Filters shall be held in place by a pivoting filter tray, facilitating easy removal and installation.
 - 3. Shall consist of factory installed, low velocity, throw-away 2-in. thick fiberglass filters.
 - 4. Filters shall be standard, commercially available sizes.
 - 5. Only one size filter per unit is allowed.
- K. (23 81 19.13.K.) Evaporator Fan and Motor with EcoBlue™ Technology:
- 1. Direct Drive Evaporator fan motor:
 - a. Shall be a ECM motor design.
 - b. Shall have permanently lubricated bearings.
 - c. Shall have inherent automatic-reset thermal overload protection.
 - d. Shall have slow ramp up to speed capabilities.
 - e. Shall require no fan/motor belts for operation, adjustments and or initial fan speed set up.
 - f. Fan DC voltage set up on Unit Control Board can eliminate the need of removal of blower access door, required on conventional belt drive systems.
 - g. Shall be internally protected from electrical phase reversal and loss.
 - 2. Evaporator Fan:
 - a. Shall be easily set with dedicated selection switch and adjustment pot on unit control board or through SystemVu™ controller.
 - b. On sizes 04-06 single speed indoor fan operation provided and on 07 size model with two stage cooling capacity control, the indoor fan speed is automatically controlled to meet the code-compliant 66% low fan speed and 100% at full fan speed operation.
- c. Blower fan shall be a Vane Axial fan design with 75% less moving parts than a conventional belt drive system.
- d. Shall be constructed of a cast aluminum stator and high impact composite material on rotor and air inlet casing.
 - e. Shall be a patented / pending design with a corrosion resistant material and dynamically balanced.
 - f. Shall have slow ramp up to speed capabilities to help reduce sound and comfort issues typically associated with single speed belt drive systems.
 - g. Shall be a slide out design with two screw removal.
3. Shall include an easily accessible unit Control Board to conveniently and safely provide connection points for vital control functions such as: smoke detectors, phase monitor, economizer, thermostat, DDC control options, and low and high pressure switches. Controller shall also provide an intuitive means to adjust the indoor fan speed through a simple switch and pot adjustment design.
- L. (23 81 19.13.L.) Condenser Fans and Motors:
- 1. Condenser fan motors:
 - a. Shall be a totally enclosed motor.
 - b. Shall use permanently lubricated bearings.
 - c. Shall have inherent thermal overload protection with an automatic reset feature.
 - d. Shall use a shaft-down design on all sizes.
 - 2. Condenser Fans:
 - a. Shall be a direct-driven propeller type fan constructed of high impact composite material.
 - b. Shall have high impact composite blades completely formed into one piece without blade fasteners or connectors and shall be dynamically balanced.
- M. (23 81 19.13.M.) Special Features Options and Accessories:
- 1. Integrated EconoMi\$er® IV, EconoMi\$er2, and EconoMi\$er X low leak rate models. (EconoMi\$er 2, IV and X are factory-installed on 04-06 models. EconoMi\$er 2 and X are factory-installed on 07 models. All are field-installed on all 3 and 1 phase models.)
 - a. Integrated, gear driven opposing modulating blade design type capable of simultaneous economizer and compressor operation.
 - b. Independent modules for vertical or horizontal return configuration shall be available.

Vertical return modules shall be available as a factory installed option.

- c. Damper blades shall be galvanized steel with composite gears. Plastic or composite blades on intake or return shall not be acceptable.
- d. Shall include all hardware and controls to provide free cooling with outdoor air when temperature and/or humidity are below setpoints.
- e. Shall be equipped with gear driven dampers for both the outdoor ventilation air and the return air for positive air stream control.
- f. Standard leak rate shall be equipped with dampers not to exceed 2% leakage at 1 in. wg pressure differential.
- g. Economizer controller on EconoMi\$er IV models shall be the W7212 that provides:
 - 1.) Combined minimum and DCV maximum damper position potentiometers with compressor staging relay.
 - 2.) Functions with solid-state analog enthalpy or dry bulb changeover control sensing.
 - 3.) Contain LED indicates for: when free cooling is available, when module is in DCV mode, when exhaust fan contact is closed.
- h. Economizer controller on EconoMi\$er X models shall be the W7220 that provides:
 - 1.) 2-line LCD interface screen for setup, configuration and troubleshooting.
 - 2.) On-board Fault Detection and Diagnostics (FDD) that senses and alerts when the economizer is not operating properly, per California Title 24, ASHRAE 90.1 and IECC¹.
 - 3.) Sensor failure loss of communication identification.
 - 4.) Automatic sensor detection.
 - 5.) Capabilities for use with multiple-speed or single speed indoor fan systems.
 - 6.) Utilize digital sensors: Dry bulb and Enthalpy.
- i. Economizer controller on EconoMi\$er 2 models with RTU Open or SystemVu™ controls shall be a 4 to 20mA design controlled directly by the controller. RTU Open and SystemVu meet California Title 24, ASHRAE 90.1 and IECC Fault Detection and Diagnostic (FDD) requirements.
- j. Shall be capable of introducing up to 100% outdoor air.
- k. Shall be equipped with a barometric relief damper capable of relieving up to 100%

1. IECC is a registered trademark of the International Code Council, Inc.

return air and contain seals that meet ASHRAE 90.1 requirements.

- l. Shall be designed to close damper(s) during loss-of-power situations with spring return built into motor.
 - m. Dry bulb outdoor air temperature sensor shall be provided as standard. Enthalpy sensor is also available on factory installed only. Outdoor air sensor setpoint shall be adjustable and shall range from 40°F to 100°F (4°C to 38°C). Additional sensor options shall be available as accessories.
 - n. The economizer controller shall also provide control of an accessory power exhaust unit function. Factory set at 100%, with a range of 0% to 100%.
 - o. The economizer shall maintain minimum air-flow into the building during occupied period and provide design ventilation rate for full occupancy.
 - p. Dampers shall be completely closed when the unit is in the unoccupied mode.
 - q. Economizer controller shall accept a 2 to 10 vdc CO₂ sensor input for IAQ/DCV control. In this mode, dampers shall modulate the outdoor air damper to provide ventilation based on the sensor input.
 - r. Compressor lockout temperature on W7220 control is adjustable from -45°F (-43°C) to 80°F (27°C), set at a factory default of 32°F (0°C). W7212 control opens at 35°F (2°C) and closes at 50°F (10°C).
 - s. Actuator shall be direct coupled to economizer gear. No linkage arms or control rods shall be acceptable.
 - t. Economizer controller shall provide indications when in free cooling mode, in the DCV mode, or the exhaust fan contact is closed.
2. Integrated EconoMi\$er®2, and EconoMi\$er X Ultra Low Leak rate models. (Factory-installed on 3 phase models only. Field-installed on all 3 and 1 phase models.)
 - a. Integrated, gear driven opposing modulating blade design type capable of simultaneous economizer and compressor operation.
 - b. Independent modules for vertical or horizontal return configuration shall be available. Vertical return modules shall be available as a factory-installed option.
 - c. Damper blades shall be galvanized steel with composite gears. Plastic or composite blades on intake or return shall not be acceptable.
 - d. Shall include all hardware and controls to provide free cooling with outdoor air when temperature and/or humidity are below setpoints.

- e. Shall be equipped with gear driven dampers for both the outdoor ventilation air and the return air for positive air stream control.
 - f. Ultra Low Leak design meets California Title 24 section 140.4 and ASHRAE 90.1 requirements for 4 cfm per sq.ft. on the outside air dampers and 10 cfm per sq. ft. on the return dampers.
 - g. Economizer controller on EconoMi\$er X models shall be the W7220 that provides:
 - 1.) 2-line LCD interface screen for setup, configuration and troubleshooting.
 - 2.) On-board Fault Detection and Diagnostics (FDD) that senses and alerts when the economizer is not operating properly, per California Title 24, ASHRAE 90.1 and IECC.
 - 3.) Sensor failure loss of communication identification.
 - 4.) Automatic sensor detection.
 - 5.) Capabilities for use with multiple-speed indoor fan systems.
 - 6.) Utilize digital sensors: Dry bulb and Enthalpy.
 - h. Economizer controller on EconoMi\$er 2 models with RTU Open or SystemVu™ controls shall be a 4-20mA design controlled directly by the controller. RTU Open and SystemVu meet California Title 24, ASHRAE 90.1 and IECC Fault Detection and Diagnostic (FDD) requirements.
 - i. Shall be capable of introducing up to 100% outdoor air.
 - j. Shall be equipped with a barometric relief damper capable of relieving up to 100% return air and contain seals that meet ASHRAE 90.1 requirements.
 - k. Shall be designed to close damper(s) during loss-of-power situations with spring return built into motor.
 - l. Dry bulb outdoor air temperature sensor shall be provided as standard. Enthalpy sensor is also available on factory installed only. Outdoor air sensor setpoint shall be adjustable and shall range from 40°F to 100°F (4°C to 38°C). Additional sensor options shall be available as accessories.
 - m. The economizer controller shall also provide control of an accessory power exhaust unit function. Factory set at 100%, with a range of 0% to 100%.
 - n. The economizer shall maintain minimum airflow into the building during occupied period and provide design ventilation rate for full occupancy.
 - o. Dampers shall be completely closed when the unit is in the unoccupied mode.
 - p. Economizer controller shall accept a 2 to 10 vdc CO₂ sensor input for IAQ/DCV control. In this mode, dampers shall modulate the outdoor air damper to provide ventilation based on the sensor input.
 - q. Compressor lockout temperature on W7220 control is adjustable from -45°F (-43°C) to 80°F (27°C), set at a factory default of 32°F (0°C). W7212 control opens at 35°F (2°C) and closes at 50°F (10°C).
 - r. Actuator shall be direct coupled to economizer gear. No linkage arms or control rods shall be acceptable.
 - s. Economizer controller shall provide indications when in free cooling mode, in the DCV mode, or the exhaust fan contact is closed.
3. Two-Position Damper (Factory-installed on 3 Phase 04-06 Models Only. Field-installed on all 3 and 1 Phase Models)
 - a. Damper shall be a Two-Position Damper. Damper travel shall be from the full closed position to the field adjustable %-open setpoint.
 - b. Damper shall include adjustable damper travel from 25% to 100% (full open).
 - c. Damper shall include single or dual blade, gear driven dampers and actuator motor.
 - d. Actuator shall be direct coupled to damper gear. No linkage arms or control rods shall be acceptable.
 - e. Damper will admit up to 100% outdoor air for applicable rooftop units.
 - f. Damper shall close upon indoor (evaporator) fan shutoff and/or loss of power.
 - g. The damper actuator shall plug into the rooftop unit's wiring harness plug. No hard wiring shall be required.
 - h. Outside air hood shall include aluminum water entrainment filter.
 4. Manual damper (field-installed only):
 - a. Manual damper package shall consist of damper, air inlet screen, and rain hood which can be preset to admit up to 25% or 50% outdoor air for year round ventilation.
 5. Low Ambient Control Package:
 - a. Controller shall control coil head pressure by condenser fan speed modulation or condenser fan cycling and wind baffles.
 - b. Shall consist of solid-state control and condenser coil temperature sensor to maintain condensing temperature between 90°F (32°C) and 110°F (43°C) at outdoor ambient temperatures down to -20°F (-29°C).
 6. Condenser Coil Hail Guard Assembly (Factory-installed on 3 Phase Models Only. Field-installed on all 3 and 1 Phase Models.)
 - a. Shall protect against damage from hail.

- b. Shall be either hood style or louvered.
- 7. Unit-Mounted, Non-Fused Disconnect Switch (Available on units with MOCPS of 80 amps or less):
 - a. Switch shall be factory installed, internally mounted.
 - b. National Electric Code (NEC) and UL approved non-fused switch shall provide unit power shutoff.
 - c. Shall be accessible from outside the unit.
 - d. Shall provide local shutdown and lockout capability.
 - e. Sized only for the unit as ordered from the factory. Does not accommodate field-installed devices.
- 8. Convenience Outlet:
 - a. Powered convenience outlet: (3 Phase Models Only)
 - 1.) Outlet shall be powered from main line power to the rooftop unit.
 - 2.) Outlet shall be powered from line side or load side of disconnect by installing contractor, as required by code. If outlet is powered from load side of disconnect, unit electrical ratings shall be UL certified and rated for additional outlet amperage.
 - 3.) Outlet shall be factory-installed and internally mounted with easily accessible 115-v female receptacle.
 - 4.) Outlet shall include 15 amp GFI receptacles with independent fuse protection.
 - 5.) Voltage required to operate convenience outlet shall be provided by a factory installed step-down transformer.
 - 6.) Outlet shall be accessible from outside the unit.
 - 7.) Outlet shall include a field installed "Wet in Use" cover.
 - b. Factory-Installed Non-Powered convenience outlet:
 - 1.) Outlet shall be powered from a separate 115/120v power source.
 - 2.) A transformer shall not be included.
 - 3.) Outlet shall be factory-installed and internally mounted with easily accessible 115-v female receptacle.
 - 4.) Outlet shall include 15 amp GFI receptacles with independent fuse protection.
 - 5.) Outlet shall be accessible from outside the unit.
 - 6.) Outlet shall include a field installed "Wet in Use" cover.
 - c. Field-Installed Non-Powered convenience outlet:
 - 1.) Outlet shall be powered from a separate 115/120v power source.
 - 2.) A transformer shall not be included.
- 3.) Outlet shall be field-installed and internally mounted with easily accessible 115-v female receptacle.
- 4.) Outlet shall include 20 amp GFI receptacles. This kit provides a flexible installation method which allows code compliance for height requirements of the GFCI outlet from the finished roof surface as well as the capability to relocate the outlet to a more convenient location.
- 5.) Outlet shall be accessible from outside the unit.
- 6.) Outlet shall include a field installed "Wet in Use" cover.
- 9. Thru-the-Base Connectors:
 - a. Kits shall provide connectors to permit gas and electrical connections to be brought to the unit through the unit basepan.
 - b. Minimum of four connection locations per unit.
- 10. Propeller Power Exhaust:
 - a. Power exhaust shall be used in conjunction with an integrated economizer.
 - b. Independent modules for vertical or horizontal return configurations shall be available.
 - c. Horizontal power exhaust is shall be mounted in return ductwork.
 - d. Power exhaust shall be controlled by economizer controller operation. Exhaust fans shall be energized when dampers open past the 0 to 100% adjustable setpoint on the economizer control.
- 11. Roof Curbs (Vertical):
 - a. Full perimeter roof curb with exhaust capability providing separate air streams for energy recovery from the exhaust air without supply air contamination.
 - b. Formed galvanized steel with wood nailer strip and shall be capable of supporting entire unit weight.
 - c. Permits installation and securing of ductwork to curb prior to mounting unit on the curb.
- 12. Outdoor Air Enthalpy Sensor:
 - a. The outdoor air enthalpy sensor shall be used to provide single enthalpy control. When used in conjunction with a return air enthalpy sensor, the unit will provide differential enthalpy control. The sensor allows the unit to determine if outside air is suitable for free cooling.
- 13. Return Air Enthalpy Sensor:
 - a. The return air enthalpy sensor shall be used in conjunction with an outdoor air enthalpy sensor to provide differential enthalpy control.
- 14. Indoor Air Quality (CO₂) Sensor:
 - a. Shall be able to provide demand ventilation indoor air quality (IAQ) control.

- b. The IAQ sensor shall be available in duct mount, wall mount, or wall mount with LED display. The setpoint shall have adjustment capability.
15. Smoke detectors (factory-installed only):
- a. Shall be a four-wire controller and detector.
 - b. Shall be environmental compensated with differential sensing for reliable, stable, and drift-free sensitivity.
 - c. Shall use magnet-activated test/reset sensor switches.
 - d. Shall have tool-less connection terminal access.
 - e. Shall have a recessed momentary switch for testing and resetting the detector.
 - f. Controller shall include:
 - 1.) One set of normally open alarm initiation contacts for connection to an initiating device circuit on a fire alarm control panel.
 - 2.) Two Form-C auxiliary alarm relays for interface with rooftop unit or other equipment.
 - 3.) One Form-C supervision (trouble) relay to control the operation of the Trouble LED on a remote test/reset station.
 - 4.) Capable of direct connection to two individual detector modules.
 - 5.) Can be wired to up to 14 other duct smoke detectors for multiple fan shut-down applications.
16. Winter Start Kit:
- a. Shall contain a bypass device around the low pressure switch.
 - b. Shall be required when mechanical cooling is required down to 25°F (-4°C).
 - c. Shall not be required to operate on an economizer when below an outdoor ambient of 40°F (4°C).
17. Time Guard Control Circuit:
- a. Shall prevent compressor short-cycling by providing a 5 minute delay (± 2 minutes) before restarting a compressor after shut-down for any reason.
 - b. One device shall be required per compressor.
18. Hinged Access Panels:
- a. Shall provide easy access through integrated quarter turn latches.
 - b. Shall be on major panels of: filter, control box, fan motor, and compressor.
19. Condensate overflow switch:
- a. This sensor and related controller monitors the condensate level in the drain pan and shuts down compression operation when overflow conditions occur. It includes:
 - 1.) Indicator light — solid red (more than 10 seconds on water contact – compressors disabled), blinking red (sensor disconnected).
 - 2.) 10 second delay to break — eliminates nuisance trips from splashing or waves in pan (sensor needs 10 seconds of constant water contact before tripping).
 - 3.) Disables the compressor(s) operation when condensate plug is detected, but still allows fans to run for Economizer.
20. MERV-8 Return Air Filters:
- a. Factory option to upgrade standard unit filters to MERV-8 filters.
21. Phase Monitor Control:
- a. Shall monitor the sequence of three phase electrical system to provide a phase reversal protection.
 - b. Shall monitor the three phase voltage inputs to provide a phase loss protection for the three phase device.
 - c. Will work on either a Delta or Wye power connection.
22. Horn/Strobe Annunciator:
- a. Provides an audible/visual signaling device for use with factory-installed option or field installed accessory smoke detectors.
 - 1.) Requires installation of a field-supplied 24-v transformer suitable for 4.2 VA (AC) or 3.0 VA (DC) per horn/strobe accessory.
 - 2.) Requires field-supplied electrical box, North American 1-gang box, 2-in. (51 mm) x 4-in. (102 mm).
 - 3.) Shall have a clear colored lens.
23. Electric Heat:
- a. Heating Section:
 - 1.) Heater element open coil resistance wire, nickel-chrome alloy, 0.29 inches inside diameter, strung through ceramic insulators mounted on metal frame. Coil ends are staked and welded to terminal screw slots.
 - 2.) Heater assemblies are provided with integral fusing for protection of internal heater circuits not exceeding 48 amps each. Auto reset thermo limit controls, magnetic heater contactors (24 v coil) and terminal block all mounted in electric heater control box (minimum 18 ga galvanized steel) attached to end of heater assembly.

