



## Product Data

# WeatherMaker® Single Packaged Rooftop

7.5 to 15 Nominal Tons

ecoblue™  technology



48/50FC\*\*08, 09, 12, 14, 16

48FC: Single-Package Gas Heating/Electric Cooling Rooftop Units  
50FC: Electric Cooling Rooftop Units with Optional Electric Heat  
with Puron® Refrigerant (R-410A) and EcoBlue Technology

**The New Carrier WeatherMaker® rooftop units (RTU) with EcoBlue™ Technology were designed by customers with integrated new technology to provide value added benefits never seen in this type of equipment before.**

New major design features include:

- Patented, industry’s first efficient indoor fan system using Vane Axial fan with electric commutated variable speed motor. As compared to today’s typically used belt drive with forward curve fans, system provides reliable operation with:
  - 75% fewer moving parts
  - No fan belts, pulleys, shaft, and shaft bearings
  - 40% more efficient than traditional belt drive forward curve fans
  - Slow ramp up capability for better sound and comfort control
  - Internal protection from phase reversal and phase loss situations
  - High external static capability
  - Slide out blower assembly design
- Reliable and highly safety protected 2 stage cooling with tandem scroll compressors technology, fully active evaporator coil, and mixed air temperature protection on all models
- New unit control board with intuitive indoor fan that uses simple dial and switch adjustments
- Reliable copper tube/aluminum fin condenser coil with 5/16 in. tubing to help reduce refrigerant charge and reduce weight versus prior designs

48/50FC WeatherMaker® units up to 15 tons are specifically designed to fit on Carrier roof curbs that were installed back to 1989, which makes replacement easy and eliminates the need for curb adapters, changing utility connections or supporting curb overhang situations.

2 speed staged air volume (SAV) indoor fan speed control helps deliver IEERs up to 15.0. All models are capable of either vertical or horizontal airflow without dedicated models or field install kits. The 16 size models require a field installed supply air kit.

With “no-strip” screw collars, handled access panels, and more, the unit is easy to install, easy to maintain, and easy to use. Your new 7.5 to 15 ton Carrier WeatherMaker rooftop unit (RTU) provides optimum comfort and control from a packaged rooftop.

Value-added features include:

- optional Humidi-MiZer® adaptive dehumidification system for improved part load humidity performance
- SystemVu™ intuitive intelligent controls option that provides:
  - Large full text — multi line display
  - USB Flash Port for data transfer
  - Built in iVu®, CCN and BACnet<sup>1</sup>
  - Read refrigerant pressures from display – no gauges
  - Quick LED Status — Run, Alert, Fault
  - Conventional thermostat or sensor capabilities
  - Historical component runtime and starts

- Supply air tempering
- Navigator™ and Network Service Tool compatible
- single point gas and electrical connections
- 7.5 to 15 ton models use fixed TXV refrigerant metering devices
- Scroll compressors with internal line-break overload protection
- Units come with an easy access tool-less filter door. Filter track tilts out for filter removal and replacement. All filters are the same size in each unit

### Installation ease

All WeatherMaker units are field-convertible to horizontal airflow, which makes it easy to adjust to unexpected job-site complications. Lighter units make for easy replacement and aid in the structural approval process. Units have simple, fast plug-in connections to the standard integrated unit control board (UCB). Clearly labeled connections points to reduce installation time. Also, a large control box provides room to work and room to mount Carrier accessory controls.

### Easy to maintain

With the new EcoBlue Vane Axial fan system and direct drive ECM motor, there is no longer a need to adjust or replace belts or pulleys as in past designs. This frees up maintenance, installation and commissioning time.

Easy access handles by Carrier provide quick and easy access to all normally serviced components. Our “no-strip” screw system has superior holding power and guides screws into position while preventing the screw from stripping the unit’s metal.

Sloped, corrosion resistant composite drain pan sheds water; and won’t rust.

1. BACnet is a trademark of ASHARE.

## Table of contents

	Page
Features/Benefits . . . . .	2
Model Number Nomenclature . . . . .	4
Capacity Ratings . . . . .	6
Physical Data . . . . .	10
Options and Accessories . . . . .	14
Base Unit Dimensions . . . . .	19
Accessory Dimensions . . . . .	37
Performance Data . . . . .	39
Fan Data . . . . .	61
Electrical Data . . . . .	102
Typical Wiring Diagrams . . . . .	131
Sequence of Operation . . . . .	149
Application Data . . . . .	151
Guide Specifications . . . . .	153

## Easy to use

The newly re-designed Unit Control Board by Carrier puts all connections and troubleshooting points in one convenient place. Most low voltage connections are made to the same board and make it easy to access it. Setting up the fan is simple by an intuitive switch and rotary dial arrangement. Carrier rooftops have high and low pressure switches, a new mixed air temperature switch, a filter drier, and 2-in. filters standard.

## EcoBlue™ Technology

Direct drive EcoBlue Technology indoor fan system uses Vane Axial fan design and electrically commutated motors.

This new Vane Axial design over past belt drive systems has 75% fewer moving parts, uses up to 40% less energy and has no fan belts, blower bearings and shaft. Full fan and motor assembly

also slides out for easier maintenance and service.

## Streamlined control and integration

Carrier controllers make connecting WeatherMaker® rooftops into existing building automation systems easy. The units are compatible with conventional thermostat controls or SystemVu™ controls for greater comfort, diagnostics and building network integration.

## Operating efficiency and flexibility

These 48/50FC packaged rooftops meet the Department of Energy (DOE) 2023 efficiency standard, as well as the latest ASHRAE (American Society of Heating, Refrigerating, and Air-Conditioning Engineers) 90.1 and IECC<sup>1</sup> (International Energy Conservation Code) minimum IEER efficiency requirements.

## Field convertible airflow

All WeatherMaker 7.5 to 15 ton units are field-convertible to horizontal airflow, which makes it easy to adjust to unexpected job-site. 15 ton models require a simple supply duct cover kit to field convert from factory vertical to horizontal.

## Comfort control

Carrier's patented Humidi-MiZer® adaptive dehumidification system is an all-inclusive factory-installed option on gas heating/electric cooling and electric cooling/electric heat models. This system provides reliable, flexible operation to meet indoor part load sensible and latent requirements as well as multiple gas heat and electric heat sized to fit an array of applications.

1. IECC is a registered trademark of the International Code Council, Inc.

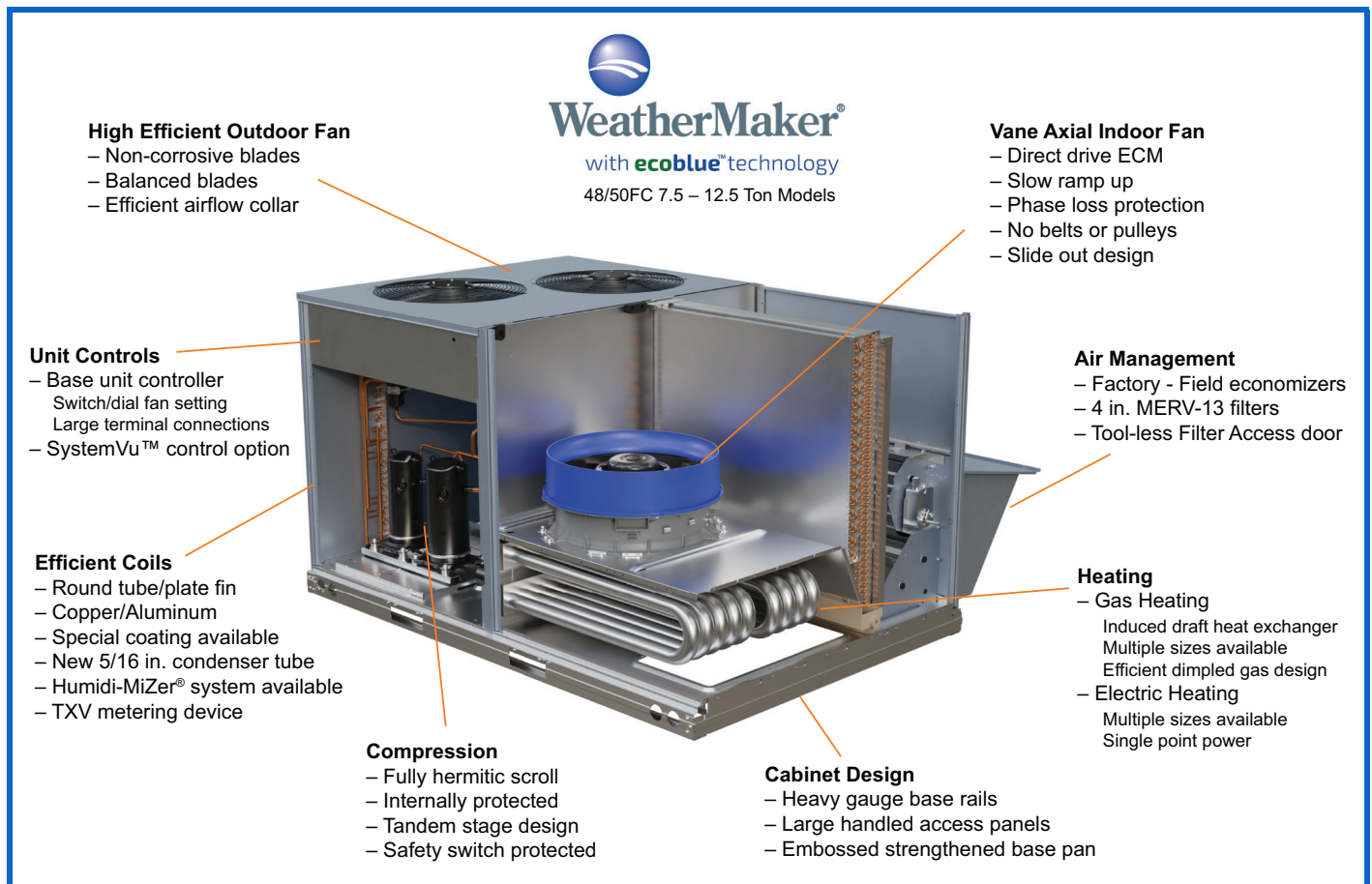

## 48FC MODEL NUMBER NOMENCLATURE

Position:	1	2	3	4	5	6	7	8	9	10	11	12	13	14	15	16	17	18
Example:	4	8	F	C	D	M	0	8	A	2	A	5	-	0	A	0	A	0

### Unit Heat Type

48 - Gas Heat Packaged Rooftop

### Model Series - WeatherMaker®

FC - Standard Efficiency (EcoBlue™ Technology)

### Heat Options

D = Low Heat  
 E = Medium Heat  
 F = High Heat  
 S = Low Heat w/ Stainless Steel Exchanger  
 R = Medium Heat w/ Stainless Steel Exchanger  
 T = High Heat w/ Stainless Steel Exchanger

### Refrig. Systems Options

M = Two Stage Cooling/One Circuit Models  
 N = Two Stage Cooling/One Circuit Models with Humidi-MiZer® System

### Cooling Tons

08 = 7.5 tons  
 09 = 8.5 tons  
 12 = 10 tons  
 14 = 12.5 tons  
 16 = 15 tons

### Sensor Options

A = None  
 B = RA Smoke Detector  
 C = SA Smoke Detector  
 D = RA + SA Smoke Detector  
 E = CO<sub>2</sub>  
 F = RA Smoke Detector and CO<sub>2</sub>  
 G = SA Smoke Detector and CO<sub>2</sub>  
 H = RA + SA Smoke Detector and CO<sub>2</sub>  
 J = Condensate Overflow Switch  
 K = Condensate Overflow Switch + RA Smoke Detectors  
 L = Condensate Overflow Switch + RA and SA Smoke Detectors  
 M = Condensate Overflow Switch + SA Smoke Detector  
 N = Condensate Overflow Switch + CO<sub>2</sub>  
 P = Condensate Overflow Switch + RA Smoke Detector and CO<sub>2</sub>  
 Q = Condensate Overflow Switch + SA Smoke Detector and CO<sub>2</sub>  
 R = Condensate Overflow Switch + RA and SA Smoke Detector and CO<sub>2</sub>

### Indoor Fan Options

2 = Standard/Medium Static Option  
 3 = High Static Option  
 5 = Standard/Medium Static Option and Filter Status Switch  
 6 = High Static Option and Filter Status Switch

### Coil Options – RTPF (Outdoor – Indoor – Hail Guard)

A = Al/Cu – Al/Cu  
 B = Precoat Al/Cu – Al/Cu  
 C = E-coat Al/Cu – Al/Cu  
 D = E-coat Al/Cu – E-coat Al/Cu  
 E = Cu/Cu – Al/Cu  
 F = Cu/Cu – Cu/Cu  
 M = Al/Cu – Al/Cu – Louvered Hail Guard  
 N = Precoat Al/Cu – Al/Cu – Louvered Hail Guard  
 P = E-coat Al/Cu – Al/Cu – Louvered Hail Guard  
 Q = E-coat Al/Cu – E-coat Al/Cu – Louvered Hail Guard  
 R = Cu/Cu – Al/Cu – Louvered Hail Guard  
 S = Cu/Cu – Cu/Cu – Louvered Hail Guard

### Packaging Compliance

0 = Standard  
 1 = LTL

### Electrical Options

A = None  
 C = Non-Fused Disconnect  
 D = Thru-The-Base Connections  
 F = Non-Fused Disconnect and Thru-The-Base Connections  
 N = Phase Monitor/Protection  
 Q = Phase Monitor/Protection and Non-Fused Disconnect  
 R = Phase Monitor/Protection and Thru-The-Base Connections  
 T = Phase Monitor/Protection with Non-Fused Disconnect and Thru-The-Base Connections  
 1 = High SCCR (Short Circuit Current Rating) Protection  
 2 = High SCCR Protection and Thru-The-Base Connections

### Service Options

0 = None  
 1 = Unpowered Convenience Outlet  
 2 = Powered Convenience Outlet  
 3 = Hinged Access Panels  
 4 = Hinged Access Panels and Unpowered Convenience Outlet  
 5 = Hinged Access Panels and Powered Convenience Outlet  
 6 = 4" MERV 13 High Efficiency Filter Track  
 7 = Unpowered Convenience Outlet and 4" MERV 13 High Efficiency Filter Track  
 8 = Powered Convenience Outlet and 4" MERV 13 High Efficiency Filter Track  
 9 = Hinged Access Panels and 4" MERV 13 High Efficiency Filter Track  
 A = Hinged Access Panels, Unpowered Convenience Outlet and 4" MERV 13 High Efficiency Filter Track  
 B = Hinged Access Panels, Powered Convenience Outlet and 4" MERV 13 High Efficiency Filter Track

### Intake / Exhaust Options

A = None  
 B = Temperature Economizer w/ Barometric Relief  
 F = Enthalpy Economizer w/ Barometric Relief  
 U = Temperature Ultra Low Leak Economizer w/ Barometric Relief  
 W = Enthalpy Ultra Low Leak Economizer w/ Barometric Relief

### Base Unit Controls

0 = Electro-mechanical Controller  
 3 = SystemVu™ Controller  
 6 = Electro-mechanical Controller POL224 with Economizer Control. Can be used with EconomizerONE (w/ Fault Detection and Diagnostic)

### Design Revision

- = Factory Design Revision

### Voltage

1 = 575/3/60  
 5 = 208-230/3/60  
 6 = 460/3/60

# Model number nomenclature (cont)



## 50FC MODEL NUMBER NOMENCLATURE

Position:	1	2	3	4	5	6	7	8	9	10	11	12	13	14	15	16	17	18
Example:	5	0	F	C	-	M	0	8	A	2	A	5	-	0	A	0	A	0

### Unit Heat Type

50 – Cooling with Optional Electric Heat Packaged Rooftop

### Model Series - WeatherMaker®

FC – Standard Efficiency (EcoBlue™ Technology)

### Heat Size

- = No heat  
(Field Installed Available)

### Refrig. Systems Options

M = Two Stage Cooling, Single Circuit  
N = Two Stage Cooling, Single Circuit with Humidi-MiZer® system

### Cooling Tons

08 = 7.5 tons  
09 = 8.5 tons  
12 = 10.0 tons  
14 = 12.5 tons  
16 = 15 tons

### Sensor Options

A = None  
B = Return Air (RA) Smoke Detector  
C = Supply Air (SA) Smoke Detector  
D = RA + SA Smoke Detector  
E = CO<sub>2</sub> Sensor  
F = RA Smoke Detector and CO<sub>2</sub> Sensor  
G = SA Smoke Detector and CO<sub>2</sub> Sensor  
H = RA + SA Smoke Detector and CO<sub>2</sub> Sensor  
J = Condensate Overflow Switch  
K = Condensate Overflow Switch and RA Smoke Detector  
L = Condensate Overflow Switch and RA and SA Smoke Detectors  
M = Condensate Overflow Switch and SA Smoke Detector  
N = Condensate Overflow Switch + CO<sub>2</sub>  
P = Condensate Overflow Switch + RA Smoke Detector and CO<sub>2</sub>  
Q = Condensate Overflow Switch + SA Smoke Detector and CO<sub>2</sub>  
R = Condensate Overflow Switch + RA and SA Smoke Detector and CO<sub>2</sub>

### Indoor Fan Options

2 = Standard/Medium Static Motor – Vane Axial EcoBlue  
3 = High Static Motor – Vane Axial EcoBlue  
5 = Standard/Medium Static Motor – Vane Axial EcoBlue and Filter Status Switch  
6 = High Static Motor – Vane Axial EcoBlue and Filter Status Switch

### Coil Options – (Outdoor - Indoor - Hail Guard)

A = Al/Cu - Al/Cu  
B = Precoat Al/Cu - Al/Cu  
C = E-coat Al/Cu - Al/Cu  
D = E-coat Al/Cu - E-coat Al/Cu  
E = Cu/Cu - Al/Cu  
F = Cu/Cu - Cu/Cu  
M = Al/Cu - Al/Cu — Louvered Hail Guard  
N = Precoat Al/Cu - Al/Cu — Louvered Hail Guard  
P = E-coat Al/Cu - Al/Cu — Louvered Hail Guard  
Q = E-coat Al/Cu - E-coat Al/Cu — Louvered Hail Guard  
R = Cu/Cu - Al/Cu — Louvered Hail Guard  
S = Cu/Cu - Cu/Cu — Louvered Hail Guard

### Packaging & Seismic Compliance

0 = Standard  
1 = LTL

### Electrical Options

A = None  
C = Non-Fused Disconnect  
D = Thru-The-Base Connections  
F = Non-Fused Disconnect and Thru-The-Base Connections  
N = Phase Monitor/Protection  
Q = Phase Monitor/Protection and Non-Fused Disconnect  
R = Phase Monitor/Protection and Thru-The-Base Connections  
T = Phase Monitor/Protection with Non-Fused Disconnect and Thru-The-Base Connections  
1 = High SCCR (Short Circuit Current Rating) Protection  
2 = High SCCR Protection and Thru-The-Base Connections

### Service Options

0 = None  
1 = Unpowered Convenience Outlet  
2 = Powered Convenience Outlet  
3 = Hinged Panels  
4 = Hinged Panels and Unpowered Convenience Outlet  
5 = Hinged Access Panels and Powered Convenience Outlet  
6 = 4" MERV 13 High Efficiency Filter Track  
7 = Unpowered Convenience Outlet and 4" MERV 13 High Efficiency Filter Track  
8 = Powered Convenience Outlet and 4" MERV 13 High Efficiency Filter Track  
9 = Hinged Access Panels and 4" MERV 13 High Efficiency Filter Track  
A = Hinged Access Panels, Unpowered Convenience Outlet and 4" MERV 13 High Efficiency Filter Track  
B = Hinged Access Panels, Powered Convenience Outlet and 4" MERV 13 High Efficiency Filter Track

### Intake / Exhaust Options

A = None  
B = Temperature Economizer w/ Barometric Relief  
F = Enthalpy Economizer w/ Barometric Relief  
U = Temperature Ultra Low Leak Economizer w/ Barometric Relief  
W = Enthalpy Ultra Low Leak Economizer w/ Barometric Relief

### Base Unit Controls

0 = Electro-mechanical Controller  
3 = SystemVu™ Controller  
6 = Electro-mechanical Controller with W7220 Economizer Control. Can be used with EconoMi\$er X (w/ Fault Detection and Diagnostic)

### Design Revision

- = Factory Design Revision

### Voltage

1 = 575/3/60  
5 = 208-230/3/60  
6 = 460/3/60

## 48FC AHRI RATINGS

48FC UNIT	COOLING STAGES	NOMINAL CAPACITY (TONS)	NET COOLING CAPACITY (MBH)	TOTAL POWER (kW)	EER	IEER WITH 2-SPEED INDOOR FAN MOTOR	AHRI RATING CFM
48FC*M08	2	7.5	86.0	7.7	11.2	15.0	2650
48FC*M09	2	8.5	98.0	8.8	11.2	15.0	3400
48FC*M12	2	10.0	118.0	10.7	11.0	15.0	3500
48FC*M14	2	12.5	132.0	12.9	10.2	15.0	3750
48FC*M16	2	15.0	174.0	16.1	10.8	14.5	5250

### LEGEND

**AHRI** — Air-Conditioning, Heating and Refrigeration Institute  
**EER** — Energy Efficiency Ratio  
**IEER** — Integrated Energy Efficiency Ratio

### NOTES:

1. Rated in accordance with AHRI Standards 340/360.
2. Rating are based on:  
**Cooling Standard:** 80°F (27°C) db, 67°F (19°C) wb indoor air temperature and 95°F (35°C) db outdoor air temperature.  
**IEER Standard:** A measure that expresses cooling part-load EER efficiency for commercial unitary air-conditioning and heat pump equipment on the basis of weighted operation at various load capacities.
3. All 48FC units comply with ASHRAE 90.1-2019 (American Society of Heating, Refrigerating, and Air-Conditioning Engineers) and DOE-2023 (Department of Energy) Energy Standard for minimum IEER requirements.
4. 48FC units comply with US Energy Policy Act (2005). To evaluate code compliance requirements, refer to state and local codes.



## 50FC AHRI RATINGS

50FC UNIT	COOLING STAGES	NOMINAL CAPACITY (TONS)	NET COOLING CAPACITY (MBH)	TOTAL POWER (kW)	EER	IEER WITH 2-SPEED INDOOR FAN MOTOR	AHRI RATING CFM
50FC*M08	2	7.5	86.0	7.5	11.4	15.2	2650
50FC*M09	2	8.5	98.0	8.6	11.4	15.2	3400
50FC*M12	2	10.0	118.0	10.5	11.2	15.2	3500
50FC*M14	2	12.5	133.0	12.8	10.4	15.2	3750
50FC*M16	2	15.0	174.0	15.8	11.0	14.7	5250

### LEGEND

**AHRI** — Air-Conditioning, Heating and Refrigeration Institute  
**EER** — Energy Efficiency Ratio  
**IEER** — Integrated Energy Efficiency Ratio

### NOTES:

1. Rated in accordance with AHRI Standards 340/360.
2. Rating are based on:  
**Cooling Standard:** 80°F (27°C) db, 67°F (19°C) wb indoor air temperature and 95°F (35°C) db outdoor air temperature.  
**IEER Standard:** A measure that expresses cooling part-load EER efficiency for commercial unitary air-conditioning and heat pump equipment on the basis of weighted operation at various load capacities.
3. All 50FC units comply with ASHRAE 90.1-2019 (American Society of Heating, Refrigerating, and Air-Conditioning Engineers) and DOE-2023 (Department of Energy) Energy Standard for minimum IEER requirements.
4. 50FC units comply with US Energy Policy Act (2005). To evaluate code compliance requirements, refer to state and local codes.

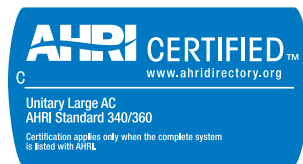

# Capacity ratings (cont)



**SOUND RATINGS TABLE**

48/50FC UNIT	COOLING STAGES	OUTDOOR SOUND (dB) at 60 Hz								
		A-WEIGHTED	63	125	250	500	1000	2000	4000	8000
<b>M08</b>	2	79	85.6	84.7	80.5	76.0	72.4	68.0	62.8	59.3
<b>M09</b>	2	79	85.6	84.7	80.5	76.0	72.4	68.0	62.8	59.3
<b>M12</b>	2	79	85.6	84.7	80.5	76.0	72.4	68.0	62.8	59.3
<b>M14</b>	2	79	85.6	84.7	80.5	76.0	72.4	68.0	62.8	59.3
<b>M16</b>	2	87	87.0	85.2	84.6	84.9	82.8	78.4	75.3	72.9

**LEGEND**

**dB** — Decibel

**NOTES:**

1. Outdoor sound data is measured in accordance with AHRI.
2. Measurements are expressed in terms of sound power. Do not compare these values to sound pressure values because sound pressure depends on specific environmental factors which normally do not match individual applications. Sound power values are independent of the environment and therefore more accurate.
3. A-weighted sound ratings filter out very high and very low frequencies, to better approximate the response of "average" human ear. A-weighted measurements for Carrier units are taken in accordance with AHRI.

# Capacity ratings (cont)



## MINIMUM - MAXIMUM AIRFLOW RATINGS (CFM) — NATURAL GAS AND PROPANE

UNIT	HEAT LEVEL	COOLING			HEATING <sup>a</sup>	
		MINIMUM 2-SPEED AIRFLOW (LOW SPEED)	MINIMUM 2-SPEED AIRFLOW (HIGH SPEED)	MAXIMUM AIRFLOW CFM	MINIMUM AIRFLOW CFM	MAXIMUM AIRFLOW CFM
48FC**08	LOW	1350	2250	3750	1730	3800
	MED				2100	3900
	HIGH				2240	4200
48FC**09	LOW	1275	2550	4250	1730	4750
	MED				2100	4560
	HIGH				2240	4800
48FC**12	LOW	1800	3000	5000	2100	5470
	MED				2580	5600
	HIGH				2710	5420
48FC**14	LOW	2250	3750	6250	2100	6830
	MED				2580	6720
	HIGH				2710	6330
48FC**16	LOW	2970	4500	7500	2450	9000
	MED				3000	9000
	HIGH				4040	7500

NOTE(S):

- a. Heating rating values are identical for aluminum heat exchangers and stainless steel heat exchangers.

## MINIMUM - MAXIMUM AIRFLOW RATINGS (CFM) — COOLING UNITS AND ACCESSORY ELECTRIC HEAT

UNIT	COOLING			ELECTRIC HEAT <sup>a</sup>	
	MINIMUM 2-SPEED AIRFLOW (LOW SPEED)	MINIMUM 2-SPEED AIRFLOW (HIGH SPEED)	MAXIMUM AIRFLOW CFM	MINIMUM AIRFLOW CFM	MAXIMUM AIRFLOW CFM
50FC**08	1350	2250	3750	2250	3750
50FC**09	1275	2550	4250	2550	4250
50FC**12	1800	3000	5000	3000	5000
50FC**14	2250	3750	6250	3750	6250
50FC**16	2970	4500	7500	4500	7500

NOTE(S):

- a. Electric heat modules and single point kits are available as field-installed accessories for 50FC units.



# Capacity ratings (cont)



**HEAT RATING TABLE — NATURAL GAS AND PROPANE**

UNIT	GAS HEAT	AL/SS HEAT EXCHANGER		TEMPERATURE RISE (°F)	THERMAL EFFICIENCY (%)
		INPUT/OUTPUT STAGE 1 (MBH)	INPUT/OUTPUT STAGE 2 (MBH)		
48FC**08	LOW	-/-	125/103	25-55	82
	MED	120/98	180/148	35-65	82
	HIGH	180/146	224/181	40-75	81
48FC**09	LOW	-/-	125/103	20-55	82
	MED	120/98	180/148	30-65	82
	HIGH	180/146	224/181	35-75	81
48FC**12	LOW	120/98	180/148	25-65	82
	MED	180/146	224/181	30-65	81
	HIGH	200/164	250/205	35-70	82
48FC**14	LOW	120/98	180/148	20-65	82
	MED	180/146	224/181	25-65	81
	HIGH	200/160	250/205	30-70	82
48FC**16	LOW	144/118	180/146	15-55	81
	MED	192/156	240/195	20-60	81
	HIGH	280/224	350/284	35-65	81

**LEGEND**

**MBH** — Btuh in thousands

## 48/50FC 7.5 TO 8.5 TON PHYSICAL DATA

48/50FC UNIT	48/50FC*M08	48/50FC*N08	48/50FC*M09	48/50FC*N09
<b>NOMINAL TONS</b>	7.5	7.5	8.5	8.5
<b>BASE UNIT OPERATING WT (lb) 48FC/50FC<sup>a</sup></b>	787/743	787/743	868/805	868/805
<b>REFRIGERATION SYSTEM</b>				
No. Circuits/No. Compressors/Type	1 / 2 / Scroll	1 / 2 / Scroll	1 / 2 / Scroll	1 / 2 / Scroll
Puron® (R-410A) charge (lbs-oz)	13-3	—	14-0	—
Humidi-MiZer® Puron (R-410A) charge (lbs-oz)	—	19-5	—	21-0
Metering device	TXV	TXV	TXV	TXV
Humidi-MiZer metering device	—	TXV	—	TXV
High-Pressure Trip/Reset (psig)	630/505	630/505	630/505	630/505
Low-Pressure Trip/Reset (psig)	54/117	54/117	54/117	54/117
<b>EVAPORATOR COIL</b>				
Material (Tube/Fin)	Cu/Al	Cu/Al	Cu/Al	Cu/Al
Coil Type	3/8 in. RTPF	3/8 in. RTPF	3/8 in. RTPF	3/8 in. RTPF
Rows/FPI	3/15	3/15	4/15	4/15
Total Face Area (ft <sup>2</sup> )	8.9	8.9	8.9	8.9
Condensate Drain Connection Size	3/4 in.	3/4 in.	3/4 in.	3/4 in.
<b>CONDENSER COIL</b>				
Material	Cu/Al	Cu/Al	Cu/Al	Cu/Al
Coil Type	5/16 in. RTPF	5/16 in. RTPF	5/16 in. RTPF	5/16 in. RTPF
Rows/FPI	2/18	2/18	2/18	2/18
Total Face Area (ft <sup>2</sup> )	20.5	20.5	21.4	21.4
<b>HUMIDI-MIZER COIL</b>				
Material	—	Cu/Al	—	Cu/Al
Coil Type	—	5/16 in. RTPF	—	5/16 in. RTPF
Rows/FPI	—	2/18	—	2/18
Total Face Area (ft <sup>2</sup> )	—	6.0	—	8.0
<b>EVAPORATOR FAN AND MOTOR</b>				
<b>Standard/Medium Static</b>				
Motor Qty / Drive Type	1 / Direct	1 / Direct	1 / Direct	1 / Direct
Max Cont bhp	2.4	2.4	2.4	2.4
Range (rpm)	250-2000	250-2000	250-2000	250-2000
Fan Qty/Type	1/Vane Axial	1/Vane Axial	1/Vane Axial	1/Vane Axial
Fan Diameter (in.)	22	22	22	22
<b>High Static</b>				
Motor Qty / Drive Type	1 / Direct	1 / Direct	1 / Direct	1 / Direct
Max Cont bhp	3	3	3	3
Range (rpm)	250-2200	250-2200	250-2200	250-2200
Fan Qty/Type	1/Vane Axial	1/Vane Axial	1/Vane Axial	1/Vane Axial
Fan Diameter (in.)	22	22	22	22
<b>CONDENSER FAN AND MOTOR</b>				
Qty / Motor Drive Type	2 / Direct	2 / Direct	2 / Direct	2 / Direct
Motor hp/rpm	1/4 / 1100	1/4 / 1100	1/4 / 1100	1/4 / 1100
Fan Diameter (in.)	22	22	22	22
<b>FILTERS</b>				
RA Filter Qty / Size (in.)	4 / 16x20x2	4 / 16x20x2	4 / 16x20x2	4 / 16x20x2
OA Inlet Screen Qty / Size (in.)	1 / 20x24x1	1 / 20x24x1	1 / 20x24x1	1 / 20x24x1

NOTE(S):

a. Base unit operating weight does not include weight of options.

**LEGEND**

bhp — brake horsepower  
 FPI — Fins Per Inch  
 OA — Outdoor Air  
 RA — Return Air

## 48/50FC 10 TO 12.5 TON PHYSICAL DATA

48/50FC UNIT	48/50FC*M12	48/50FC*N12	48/50FC*M14	48/50FC* N14
<b>NOMINAL TONS</b>	10.0	10.0	12.5	12.5
<b>BASE UNIT OPERATING WT (lb) 48FC/50FC<sup>a</sup></b>	878/815	878/815	1041/978	1041/978
<b>REFRIGERATION SYSTEM</b>				
No. Circuits/No. Compressors/Type	1 / 2/ Scroll	1 / 2/ Scroll	1 / 2/ Scroll	1 / 2/ Scroll
Puron® (R-410A) charge (lbs-oz)	15-3	—	19-8	—
Humidi-MiZer® Puron (R-410A) charge (lbs-oz)	—	23-3	—	28-6
Metering device	TXV	TXV	TXV	TXV
Humidi-MiZer metering device	—	TXV	—	TXV
High-Pressure Trip/Reset (psig)	630/505	630/505	630/505	630/505
Low-Pressure Trip/Reset (psig)	54/117	54/117	54/117	54/117
<b>EVAPORATOR COIL</b>				
Material (Tube/Fin)	Cu/Al	Cu/Al	Cu/Al	Cu/Al
Coil Type	3/8 in. RTPF	3/8 in. RTPF	3/8 in. RTPF	3/8 in. RTPF
Rows/FPI	4/15	4/15	4/15	4/15
Total Face Area (ft <sup>2</sup> )	11.1	11.1	11.1	11.1
Condensate Drain Connection Size	3/4 in.	3/4 in.	3/4 in.	3/4 in.
<b>CONDENSER COIL</b>				
Material	Cu/Al	Cu/Al	Cu/Al	Cu/Al
Coil Type	5/16 in. RTPF	5/16 in. RTPF	5/16 in. RTPF	5/16 in. RTPF
Rows/FPI	2/18	2/18	3/18	3/18
Total Face Area (ft <sup>2</sup> )	25.1	25.1	25.1	25.1
<b>HUMIDI-MIZER COIL</b>				
Material	—	Cu/Al	—	Cu/Al
Coil Type	—	5/16 in. RTPF	—	5/16 in. RTPF
Rows/FPI	—	2/18	—	2/18
Total Face Area (ft <sup>2</sup> )	—	8.0	—	8.0
<b>EVAPORATOR FAN AND MOTOR</b>				
<b>Standard/Medium Static</b>				
Motor Qty / Drive Type	1 / Direct	1 / Direct	1 / Direct	1 / Direct
Max Cont bhp	2.4	2.4	3	3
Range (rpm)	250-2000	250-2000	250-2200	250-2200
Fan Qty / Type	1 / Vane Axial	1 / Vane Axial	1 / Vane Axial	1 / Vane Axial
Fan Diameter (in.)	22	22	22	22
<b>High Static</b>				
Motor Qty / Drive Type	1 / Direct	1 / Direct	1 / Direct	1 / Direct
Max Cont bhp	5	5	5	5
Range (rpm)	250-2200	250-2200	250-2200	250-2200
Fan Qty / Type	1 / Vane Axial	1 / Vane Axial	1 / Vane Axial	1 / Vane Axial
Fan Diameter (in.)	22	22	22	22
<b>CONDENSER FAN AND MOTOR</b>				
Qty / Motor Drive Type	2 / Direct	2 / Direct	1 / Direct	1 / Direct
Motor hp / rpm	1/4 / 1100	1/4 / Multiple Speeds	1 / Multiple Speeds	1 / Multiple Speeds
Fan Diameter (in.)	22	22	30	30
<b>FILTERS</b>				
RA Filter Qty / Size (in.)	4 / 20x20x2	4 / 20x20x2	4 / 20x20x2	4 / 20x20x2
OA Inlet Screen Qty / Size (in.)	1 / 20x24x1	1 / 20x24x1	1 / 20x24x1	1 / 20x24x1

NOTE(S):

a. Base unit operating weight does not include weight of options.

**LEGEND**

**bhp** — brake horsepower  
**FPI** — Fins Per Inch  
**OA** — Outdoor Air  
**RA** — Return Air

## 48/50FC 15 TON PHYSICAL DATA

48/50FC UNIT	48/50FC*M16	48/50FC*N16
<b>NOMINAL TONS</b>	15.0	15.0
<b>BASE UNIT OPERATING WT (lb) 48FC/50FC<sup>a</sup></b>	1408/1325	1408/1325
<b>REFRIGERATION SYSTEM</b>		
No. Circuits/No. Compressors/Type	1 / 2/ Scroll	1 / 2/ Scroll
Puron® (R-410A) charge (lbs-oz)	24-0	34-0
Humidi-MiZer® Puron (R-410A) charge (lbs-oz)	—	34-0
Metering device	TXV	TXV
Humidi-MiZer metering device	—	—
High-Pressure Trip/Reset (psig)	630/505	630/505
Low-Pressure Trip/Reset (psig)	54/117	54/117
<b>EVAPORATOR COIL</b>		
Material (Tube/Fin)	Cu/Al	Cu/Al
Coil Type	3/8 in. RTPF	3/8 in. RTPF
Rows/FPI	3/15	3/15
Total Face Area (ft <sup>2</sup> )	17.5	17.5
Condensate Drain Connection Size	3/4 in.	3/4 in.
<b>CONDENSER COIL</b>		
Material	Cu/Al	Cu/Al
Coil Type	5/16 in. RTPF	5/16 in. RTPF
Rows/FPI	2/18	2/18
Total Face Area (ft <sup>2</sup> )	46.2	46.2
<b>HUMIDI-MIZER COIL</b>		
Material	—	Cu/Al
Coil Type	—	5/16 in. RTPF
Rows/FPI	—	2/18
Total Face Area (ft <sup>2</sup> )	—	8.0
<b>EVAPORATOR FAN AND MOTOR</b>		
<b>Standard/Medium Static</b>		
Motor Qty / Drive Type	1 / Direct	1 / Direct
Max Cont bhp	3	3
Range (rpm)	250-2000	250-2000
Fan Qty / Type	1 / Vane Axial	1 / Vane Axial
Fan Diameter (in.)	22	22
<b>High Static</b>		
Motor Qty / Drive Type	1 / Direct	1 / Direct
Max Cont bhp	5	5
Range (rpm)	250-2000	250-2000
Fan Qty / Type	1 / Vane Axial	1 / Vane Axial
Fan Diameter (in.)	22	22
<b>CONDENSER FAN AND MOTOR</b>		
Qty / Motor Drive Type	3 / Direct	3 / Direct
Motor hp / rpm	1/4 / 1100	1/4 / 1100
Fan Diameter (in.)	22	22
<b>FILTERS</b>		
RA Filter Qty / Size (in.)	6 / 18x24x2	6 / 18x24x2
OA Inlet Screen Qty / Size (in.)	Vertical: 2 / 24x27x1 Horizontal: 1 / 30x39x1	Vertical: 2 / 24x27x1 Horizontal: 1 / 30x39x1

**NOTE(S):**

a. Base unit operating weight does not include weight of options.

**LEGEND**

**bhp** — brake horsepower  
**FPI** — Fins Per Inch  
**OA** — Outdoor Air  
**RA** — Return Air

# Physical data (cont)



## 48FC 7.5 TO 15 TON GAS HEAT DATA

48FC UNIT	48FC**08	48FC**09	48FC**12	48FC**14	48FC**16
<b>NOMINAL TONS</b>	7.5	8.5	10.0	12.5	15
<b>GAS CONNECTION</b>					
<b>No. of Gas Valves</b>	1	1	1	1	1
<b>Natural Gas Supply Line Pressure (in. wg)/(psig)</b>	4-13 / 0.18-0.47	4-13 / 0.18-0.47	4-13 / 0.18-0.47	4-13 / 0.18-0.47	4-13 / 0.18-0.47
<b>Liquid Propane Supply Line Pressure (in. wg)/(psig)</b>	11-13 / 0.40-0.47	11-13 / 0.40-0.47	11-13 / 0.40-0.47	11-13 / 0.40-0.47	11-13 / 0.40-0.47
<b>HEAT ANTICIPATOR SETTING (AMPS)</b>					
<b>First Stage</b>	0.14	0.14	0.14	0.14	0.14
<b>Second Stage</b>	0.14	0.14	0.14	0.14	0.14
<b>NATURAL GAS HEAT</b>					
<b>LOW</b>					
<b>No. of Stages / No. of Burners (total)</b>	1 / 3	1 / 3	2 / 4	2 / 4	2 / 6
<b>Connection Size</b>	1/2 in. NPT	1/2 in. NPT	3/4 in. NPT	3/4 in. NPT	3/4 in. NPT
<b>Rollout Switch Opens / Closes (°F)</b>	195 / 115	195 / 115	195 / 115	195 / 115	196 / 115
<b>Temperature Rise (°F)</b>	25-55	20-55	25-65	20-65	15-55
<b>MEDIUM</b>					
<b>No. of Stages / No. of Burners (total)</b>	2 / 4	2 / 4	2 / 5	2 / 5	2 / 8
<b>Connection Size</b>	3/4 in. NPT	3/4 in. NPT	3/4 in. NPT	3/4 in. NPT	3/4 in. NPT
<b>Rollout Switch Opens / Closes (°F)</b>	195 / 115	195 / 115	195 / 115	195 / 115	197 / 115
<b>Temperature Rise (°F)</b>	35-65	30-65	30-65	25-65	20-60
<b>HIGH</b>					
<b>No. of Stages / No. of Burners (total)</b>	2 / 5	2 / 5	2 / 5	2 / 5	2 / 10
<b>Connection Size</b>	3/4 in. NPT	3/4 in. NPT	3/4 in. NPT	3/4 in. NPT	3/4 in. NPT
<b>Rollout Switch Opens / Closes (°F)</b>	195 / 115	195 / 115	195 / 115	195 / 115	198 / 115
<b>Temperature Rise (°F)</b>	40-75	35-75	35-70	30-70	35-65
<b>LIQUID PROPANE HEAT</b>					
<b>LOW</b>					
<b>No. of Stages / No. of Burners (total)</b>	1 / 3	1 / 3	2 / 4	2 / 4	2 / 6
<b>Connection Size</b>	1/2 in. NPT	1/2 in. NPT	3/4 in. NPT	3/4 in. NPT	3/4 in. NPT
<b>Rollout Switch Opens / Closes (°F)</b>	195 / 115	195 / 115	195 / 115	195 / 115	196 / 115
<b>Temperature Rise (°F)</b>	25-55	20-55	25-65	20-65	15-55
<b>MEDIUM</b>					
<b>No. of Stages / No. of Burners (total)</b>	1 / 3	1 / 3	2 / 5	2 / 5	2 / 8
<b>Connection Size</b>	1/2 in. NPT	1/2 in. NPT	1/2 in. NPT	1/2 in. NPT	3/4 in. NPT
<b>Rollout Switch Opens / Closes (°F)</b>	195 / 115	195 / 115	195 / 115	195 / 115	197 / 115
<b>Temperature Rise (°F)</b>	35-65	30-65	30-65	25-65	20-60
<b>HIGH</b>					
<b>No. of Stages / No. of Burners (total)</b>	2 / 5	2 / 5	2 / 5	2 / 5	2 / 10
<b>Connection Size</b>	3/4 in. NPT	3/4 in. NPT	3/4 in. NPT	3/4 in. NPT	3/4 in. NPT
<b>Rollout Switch Opens / Closes (°F)</b>	195 / 115	195 / 115	195 / 115	195 / 115	198 / 115
<b>Temperature Rise (°F)</b>	40-75	35-75	35-70	30-70	35-65

# Options and accessories



ITEM	OPTION <sup>a</sup>	ACCESSORY <sup>b</sup>
<b>GAS HEAT (48FC units only)</b>		
Low, Medium or High Gas Heat — Aluminized Heat Exchanger	X	
Low, Medium or High Gas Heat — Stainless Steel Heat Exchanger	X	
Propane Conversion Kit		X
High Altitude Conversion Kit		X
Flue Discharge Deflector		X
Flue Shield (08-14 sizes only)		X
<b>ELECTRIC HEAT (50FC units only)</b>		
Electric Resistance Heaters		X
Single Point Kits		X
<b>CABINET</b>		
Thru-the-Base electrical or gas-line connections	X	X
Hinged Access Panels	X	
UV-C Ultraviolet Lamp <sup>c</sup>		X
MERV-13, 4 in. Filters	X	
MERV-13, 2 in. Filters		X
MERV-8, 2 in. Filters		X
4 in. Filter Rack (filters not included)		X
Disconnect Switch Bracket <sup>d</sup>		X
Supply Duct Cover <sup>d</sup>		X
<b>COIL OPTIONS</b>		
Cu/Cu indoor and/or outdoor coils	X	
Pre-coated outdoor coils	X	
Premium, E-coated outdoor coils	X	
<b>HUMIDITY CONTROL</b>		
Humidi-MiZer <sup>®</sup> Adaptive Dehumidification System	X	
<b>CONDENSER PROTECTION</b>		
Condenser coil hail guard (louvered design)	X	X
<b>CONTROLS</b>		
Thermostats, temperature sensors, and subbases		X
SystemVu™ DDC communicating controller	X	
Smoke detector (supply and/or return air)	X	X
Horn Strobe Annunciator <sup>e</sup>		X
Time Guard II compressor delay control circuit		X
Phase Monitor	X	X

ITEM	OPTION <sup>a</sup>	ACCESSORY <sup>b</sup>
<b>ECONOMIZERS AND OUTDOOR AIR DAMPERS</b>		
EconoMiZer <sup>®</sup> IV for electro-mechanical controls - Non FDD (Standard air leak damper models) <sup>f</sup>		X
EconoMiZer2 for DDC controls (Low and Ultra Low Leak air damper models) <sup>g</sup>	X	X
EconoMiZer X for electro-mechanical controls, complies with FDD (Low and Ultra Low Leak damper models) <sup>f</sup>	X	X
Motorized 2-position outdoor-air damper		X
Manual outdoor-air damper (25% and 50%)		X
Barometric relief <sup>h</sup>	X	X
Power exhaust - prop design		X
Condensate Overflow switch	X	X
<b>ECONOMIZER SENSORS AND IAQ DEVICES</b>		
Single dry bulb temperature sensors <sup>i</sup>	X	X
Differential dry bulb temperature sensors <sup>i</sup>		X
Differential enthalpy sensors <sup>i</sup>		X
CO <sub>2</sub> sensor (wall, duct, or unit mounted) <sup>j</sup>	X	X
<b>INDOOR MOTOR AND DRIVE</b>		
Multiple motor and drive packages	X	
<b>LOW AMBIENT CONTROLS</b>		
Winter start kit <sup>k</sup>		X
Low Ambient controller to 0°F (-18°C)		X
<b>POWER OPTIONS</b>		
Convenience outlet (powered)	X	
Convenience outlet (unpowered)	X	
Convenience outlet, 20 amp (unpowered)		X
Non-fused disconnect <sup>k</sup>	X	
High SCCR Protection <sup>l</sup>	X	
<b>ROOF CURBS</b>		
Roof curb 14 in. (356 mm)		X
Roof curb 24 in. (610 mm)		X

**NOTE(S):**

- Factory-installed option.
- Field-installed accessory.
- UV-C kits can not be used on units with Humidi-MiZer system.
- For Size 16 units only.
- Requires a field-supplied 24V transformer for each application. See price pages for details.
- FDD (Fault Detection and Diagnostic) capability per California Title 24 section 120.2.
- Models with SystemVu controls comply with California Title 24 Fault Detection and Diagnostic (FDD).
- Included with economizer.
- Sensors used to optimize economizer performance.
- See application data for assistance.
- Non-fused disconnect switch cannot be used when unit FLA electrical rating exceeds –
  - Sizes 08-14: 80 amps, all voltages.
  - Size 16: 100 amps, all voltages.
 Carrier RTUBuilder automatically selects the amp limitations.
- High SCCR (Short Circuit Current Rating) is not available on the following: units with Humidi-MiZer system, Low Ambient controls, Phase loss monitor, Non-fused disconnect, and 575V.

## Factory-installed options

### Economizer (dry-bulb or enthalpy)

Economizers save money. They bring in fresh, outside air for ventilation; and provide cool, outside air to cool your building. This is the preferred method of low-ambient cooling. When coupled to CO<sub>2</sub> sensors, economizers can provide even more savings by coupling the ventilation air to only that amount required.

Economizers are available, installed and tested by the factory, with either enthalpy or dry-bulb temperature inputs. Additional sensors are available as accessories to optimize the economizers. Economizers include a powered exhaust system to help equalize building pressures.

Economizers can be factory-installed or easily field-installed.

### Unit mounted CO<sub>2</sub> sensor

The CO<sub>2</sub> sensor works with the economizer to intake only the correct amount of outside air for ventilation. As occupants fill your building, the CO<sub>2</sub> sensor detects their presence through increasing CO<sub>2</sub> levels, and opens the economizer appropriately. When the occupants leave, the CO<sub>2</sub> levels decrease, and the sensor appropriately closes the economizer. This intelligent control of the ventilation air, called demand controlled ventilation (DCV), reduces the overall load on the rooftop, saving money. It is also available as a field-installed accessory.

### Smoke detector (supply and/or return air)

Trust the experts. Smoke detectors make your application safer and your job easier. Carrier smoke detectors immediately shut down the rooftop unit when smoke is detected. They are available, installed by the factory, for supply air, return air, or both.

### Optional Humidi-MiZer<sup>®</sup> adaptive dehumidification system

Carrier's Humidi-MiZer adaptive dehumidification system is an all-inclusive factory-installed option that can be ordered with any WeatherMaker<sup>®</sup> 48/50FC\*08-16 rooftop unit.

This system expands the envelope of operation of Carrier's WeatherMaker rooftop products to provide unprecedented flexibility to meet year round comfort conditions.

The Humidi-MiZer adaptive dehumidification system has a unique dual operational mode setting. The Humidi-MiZer system provides greater dehumidification of the occupied space by two modes of dehumidification operations in addition to its normal design cooling mode.

The WeatherMaker 48/50FC\*08-16 rooftop coupled with the Humidi-MiZer system is capable of operating in normal design cooling mode, sub-cooling mode, and hot gas reheat mode. Normal design cooling mode is when the unit will operate under its normal sequence of operation by cycling compressors to maintain comfort conditions.

Sub-cooling mode will operate to satisfy part load type conditions when the space requires combined sensible and a higher proportion of latent load control. Hot Gas Reheat mode will operate when outdoor temperatures diminish and the need for latent capacity is required for sole humidity control. Hot Gas Reheat mode will provide neutral air for maximum dehumidification operation.

NOTE: Humidi-MiZer system includes Low Ambient controller.

## Thru-the-base connections

Thru-the-base connections, available as a factory option, are necessary to ensure proper connection and seal when routing wire and piping through the rooftop's basepan and curb. These couplings eliminate roof penetration and should be considered for gas lines, main power lines, as well as control power.

### Hinged access panels

Allows access to unit's major components with specifically designed hinged access panels. Panels are filter, control box access indoor fan motor access.

### Cu/Cu (indoor) coils

Copper fins and copper tubes are mechanically bonded to copper tubes and copper tube sheets. A polymer strip prevents coil assembly from contacting the sheet metal coil pan to minimize potential for galvanic corrosion between coil and pan.

### E-coated (outdoor and indoor) coils

A flexible epoxy polymer coating uniformly applied to all coil surface areas without material bridging between fins. Coating process shall ensure complete coil encapsulation of tubes, fins and headers.

### Pre-coated outdoor coils

A durable epoxy-phenolic coating to provide protection in mildly corrosive coastal environments. The coating minimizes galvanic action between dissimilar metals. Coating is applied to the aluminum fin stock prior to the fin stamping process to create an inert barrier between the aluminum fin and copper tube.

### Condenser coil hail guard

Sleek, louvered panels protect the condenser coil from hail damage, foreign objects, and incidental contact.

### Stainless steel heat exchanger (48FC units only)

The stainless steel heat exchanger option provides the tubular heat exchanger be made out of a minimum 20 gage type 409 stainless steel for applications where the mixed air to the heat exchanger is expected to drop below 45°F (7°C). Stainless steel may be specified on applications where the presence of airborne contaminants require its use (applications such as paper mills) or in area with very high outdoor humidity that may result in severe condensation in the heat exchanger during cooling operation.

### Convenience outlet (powered or un-powered)

Reduce service and/or installation costs by including a convenience outlet in your specification. Carrier will install this service feature at our factory. Provides a convenient, 15 amp, 115v GFCI receptacle with "Wet in Use" cover. The "powered" option allows the installer to power the outlet from the line side of the disconnect or load side as required by code. The "unpowered" option is to be powered from a separate 115/120v power source.

The unpowered convenience outlet is available as a 15 amp factory-installed option or a 20 amp field-installed accessory.

### Non-fused disconnect

This OSHA-compliant, factory-installed, safety switch allows a service technician to locally secure power to the rooftop. When selecting a factory-installed non-fused disconnect, note they are sized for the unit as ordered from

the factory. The sizing of these do not accommodate field-installed items such as power exhaust devices, etc. If field installing electric heat with factory-installed non-fused disconnect switch, a single point kit may or may not be required.

## **SystemVu™ controller**

Carrier's SystemVu controller is an optional factory-installed and tested controller.

This controller takes on a whole new approach to provide an intuitive, intelligent controller that not only monitors and controls the unit, but also provides linkage to multiple building automation systems.

Each SystemVu controller makes it easy to set up, service, troubleshoot, gain historical data, generate reports and provide comfort only Carrier is noted for.

*Key features include:*

- Easy to read back lit four line text screen for superior visibility.
- Quick operational condition LEDs of: Run, Alert, and Fault.
- Simple navigation with large keypad buttons of: Navigation arrows, Test, Back, Enter and Menu.
- Capable of being controlled with a conventional thermostat, space sensor or build automation system.
- Service capabilities include:
  - Auto run test
  - Manual run test
  - Component run hours and starts
  - Commissioning reports
  - Data logging
- Full range of diagnosis:
  - Read refrigerant pressures without the need of gages
  - Sensor faults
  - Compressor reverse rotation
  - Economizer diagnostics that meet California Title 24 requirements
- Quick data transfer via USB port:
  - Unit configuration uploading/downloading
  - Data logging
  - Software upgrades

- Built in capacity for:
  - i-Vu® open systems
  - BACnet systems
  - CCN systems
- Configuration and alarm point capability:
  - Contain over 100 alarm codes
  - Contain over 260 status, troubleshooting, diagnostic and maintenance points
  - Contain over 270 control configuration setpoints

## **Condensate overflow switch**

This sensor and related controller monitors the condensate level in the drain pan and shuts down compression operation when overflow conditions occur. It includes:

- Indicator light – solid red (more than 10 seconds on water contact – compressors disabled), blinking red (sensor disconnected)
- 10-second delay to break – eliminates nuisance trips from splashing or waves in pan (sensor needs 10 seconds of constant water contact before tripping)
- Disables the compressors operation when condensate plug is detected, but still allows fans to run for economizer.

## **Power exhaust with barometric relief**

Superior internal building pressure control. This field-installed accessory may eliminate the need for costly, external pressure control fans.

## **MERV-13 4 in. return air filters**

This factory option upgrades the return air filters from standard unit filters to high efficiency MERV-13 filters. Non-woven MERV-13 filter media with high strength, moisture-resistant frame. Filter media is securely fastened inside the filter frame on all four sides.

## **High Short Circuit Current Rating (SCCR) protection**

This factory-installed option provides high short circuit current protection to each compressor, plus all indoor and outdoor fan motors of 10 kA against high potential fault current situations.

Standard unit comes with 5 kA rating.

This option is not available with factory installed Non-Fused Disconnect, Humidi-MiZer system, Low Ambient controls, Phase loss monitor/protection and 575 Volt models.



## Field-installed accessories

### Filter maintenance indicator

When the optional factory-installed filter maintenance indicator is used, a factory-installed differential pressure switch measures pressure drop across the outside air filter and activates a field-supplied dry contact indicator when the pressure differential exceeds the adjustable switch setpoint.

### Condenser coil hail guard

Sleek, louvered panels protect the condenser coil from hail damage, foreign objects, and incidental contact. This can be purchased as a factory-installed option or as a field-installed accessory.

### Differential enthalpy sensor

The differential enthalpy sensor is comprised of an outdoor and return air enthalpy sensors to provide differential enthalpy control. The sensor allows the unit to determine if outside air is suitable for free cooling.

### Wall or duct mounted CO<sub>2</sub> sensor

The IAQ sensor shall be available in duct or wall mount. The sensor provides demand ventilation indoor air quality (IAQ) control.

### Propane conversion kit (48FC units only)

Convert your gas heat rooftop from standard natural gas operation to Propane using this field-installed kit.

### High altitude conversion kit (48FC units only)

High altitudes have less oxygen, which affects the fuel/air mixture in heat exchangers. In order to maintain a proper fuel/air mixture, heat exchangers operating in altitudes above 2000 ft (610 m) require different orifices. To select the correct burner orifices or determine the heat capacity for a high altitude application, use either the selection software, or the unit's service manual. High altitudes have less oxygen, which means heat exchangers need less fuel. The new gas orifices in this field-installed kit make the necessary adjustment for high altitude applications. They restore the optimal fuel to air mixture and maintain healthy combustion on altitudes above 2000 ft (610 m).

NOTE: Typical natural gas heating value ranges from 975 to 1050 Btu/ft<sup>3</sup> at sea level nationally. The heating value goes down approximately 1.7% per every thousand feet elevation. Standard factory orifices can typically be used up to 2000 ft (610 m) elevation without any operational issues.

### Flue discharge deflector (48FC units only)

The flue discharge deflector is a useful accessory when flue gas recirculation is a concern. By venting the flue discharge upwards, the deflector minimizes the chance for a neighboring unit to intake the flue exhaust.

### 4 in. filter rack kit

The 4 in. filter rack accessory kit is designed to hold 4 in. MERV-8 or MERV-13 filters. Filters not included in kit.

### MERV-13 2 in. return air filters

This kit includes MERV-13 2 in. filters (qty 4) to accommodate unit filter rack size.

### MERV-8 2 in. return air filters

This kit includes MERV-8 2 in. filters (qty 4) to accommodate unit filter rack size.

### UV-C ultraviolet lamp kit

High-output, low temperature ultraviolet lamp. Accessory kit includes lamp, interlock switch, mounting brackets, necessary wires, wire ties, screws and labels to field install kit in unit return air plenum. Separate dedicated 115v power source required. See appropriate installation instructions.

Note: UV-C kit can not be used on units with Humidi-MiZer system.

### Phase monitor protection

The Phase Monitor Control will monitor the sequence of three phase electrical system to provide a phase reversal protection; and monitor the three phase voltage inputs to provide a phase loss protection for the three phase device. It will work on either a Delta or Wye power connection.

### Winter start kit

The winter start kit by Carrier extends the low ambient limit of your rooftop to 25°F (-4°C). The kit bypasses the low pressure switch, preventing nuisance tripping of the low pressure switch. Other low ambient precautions may still be prudent.

### Low ambient controller

The low ambient controller is a head pressure controller kit that is designed to maintain the unit's condenser head pressure during periods of low ambient cooling operation. This device should be used as an alternative to economizer free cooling when economizer usage is either not appropriate or desired. The low ambient controller will either cycle the outdoor fan motors or operate them at reduced speed to maintain the unit operation, depending on the model. This controller allows cooling operation down to 0°F (-18°C) ambient conditions.

NOTE: 0°F (-18°C) is standard on size 14 models.

### Roof curb (14 in./356 mm or 24 in./610 mm)

Full perimeter roof curb with exhaust capability provides separate air streams for energy recovery from the exhaust air without supply air contamination.

### Filter status indicator accessory

Monitors static pressure across supply and exhaust filters and provides indication when filters become clogged.

### Power exhaust

Superior internal building pressure control. This field-installed accessory may eliminate the need for costly, external pressure control fans.

### Manual OA damper

Manual outdoor air dampers are an economical way to bring in ventilation air. The dampers are available in 25% and 50% versions.

NOTE: See application tip "ROOFTOP-18-01" prior to use of this damper on 08-16 size models.

### Motorized 2-Position damper

The Carrier 2-position, motorized outdoor air damper admits up to 100% outside air. Using reliable, gear-driven technology, the 2-position damper opens to allow ventilation air and closes when the rooftop stops, stopping unwanted infiltration.

NOTE: See application tip "ROOFTOP-18-01" prior to use of this damper on 08-16 size models.

# Options and accessories (cont)



## Electric heaters

Carrier offers a full-line of field-installed accessory heaters. The heaters are very easy to use, install and are all pre-engineered and certified.

## Time Guard II control circuit

This accessory protects your compressor by preventing short-cycling in the event of some other failure, prevents the compressor from restarting for 30 seconds after stopping.

Not required with SystemVu™ controller or authorized commercial thermostats.

## Disconnect switch bracket

Provides a pre-engineered and sized mounting bracket for applications requiring a unit mounted fused and non-fused disconnect of greater than 100 amps. Bracket assures that no damage will occur to coils when mounting with screws and other fasteners (16 size only).

## OPTIONS AND ACCESSORY WEIGHTS<sup>a</sup>

OPTION / ACCESSORY NAME	48/50FC UNIT WEIGHT									
	08		09		12		14		16	
	lb	kg	lb	kg	lb	kg	lb	kg	lb	kg
Humidi-MiZer® System <sup>b</sup>	25	12	34	16	34	16	34	16	55	25
Power Exhaust - Vertical	75	34	75	34	75	34	75	34	85	39
Power Exhaust - Horizontal	30	14	30	14	30	14	30	14	75	34
EconoMiZer® (X, IV or 2)	55	25	55	25	55	25	55	25	85	39
2-Position Damper	58	26	58	26	58	26	58	26	65	29
Manual Damper	18	8	18	8	18	8	18	8	25	11
Medium Gas Heat (48FC units only)	15	7	15	7	18	8	18	8	18	8
High Gas Heat (48FC units only)	30	14	30	14	27	12	27	12	36	16
Hail Guard (louvered)	17	8	17	8	17	8	17	8	44	20
Cu/Cu Condenser Coil	85	39	85	39	100	46	150	68	180	82
Cu/Cu Evaporator Coil	50	23	100	46	100	46	100	46	120	55
Roof Curb (14 in. curb)	143	65	143	65	143	65	143	65	180	82
Roof Curb (24 in. curb)	245	112	245	112	245	112	245	112	255	116
CO <sub>2</sub> Sensor	2	1	2	1	2	1	2	1	2	1
Flue Discharge Deflector	7	3	7	3	7	3	7	3	7	3
Optional Indoor Motor <sup>c</sup>	30	14	30	14	30	14	30	14	0	0
Low Ambient Controller	9	4	9	4	9	4	9	4	9	4
Winter Start Kit	5	2	5	2	5	2	5	2	5	2
Return Air Smoke Detector	7	3	7	3	7	3	7	3	7	3
Supply Air Smoke Detector	7	3	7	3	7	3	7	3	7	3
Fan Filter Switch	2	1	2	1	2	1	2	1	2	1
Non-Fused Disconnect	15	7	15	7	15	7	15	7	15	7
Powered Convenience Outlet	36	16	36	16	36	16	36	16	36	16
Unpowered Convenience Outlet	4	2	4	2	4	2	4	2	4	2
Enthalpy Sensor	2	1	2	1	2	1	2	1	2	1
Differential Enthalpy Sensor	3	1	3	1	3	1	3	1	3	1
4 in. MERV 13 Filters	11	5	14	7	14	7	14	7	20	9

NOTE(S):

- Where multiple variations are available, the heaviest combination is listed.
- For Humidi-MiZer system, add Low Ambient controller weight.
- Add the Optional Indoor Motor weight to the weight of the base unit.

## 48FC\*\*08\*12 BASE UNIT DIMENSIONS

**NOTES:**

1. DIMENSIONS ARE IN INCHES. DIMENSIONS IN [ ] ARE IN MILLIMETERS.
2. CENTER OF GRAVITY
3. DIRECTION OF AIR FLOW
4. ALL VIEW DRAWN USING 3RD ANGLE

UNIT	OUTDOOR COIL TYPE	J	K	H
48FC-M08	RTPF	41 1/4 [1046]	33 3/4 [857]	15 7/8 [403]
48FC-M09	RTPF	49 3/8 [1253]	36 3/8 [925]	15 7/8 [403]
48FC-M12	RTPF	49 3/8 [1253]	36 3/8 [925]	15 7/8 [403]

RTPF - ROUND TUBE, PLATE FIN (COPPER/ALUM)

THIS DOCUMENT IS THE PROPERTY OF CARRIER CORPORATION AND IS DELIVERED UPON THE EXPRESS CONDITION THAT THE CONTENTS WILL NOT BE DISCLOSED OR USED WITHOUT CARRIER CORPORATION'S WRITTEN CONSENT.

SUBMISSION OF THESE DRAWINGS OR DOCUMENTS DOES NOT CONSTITUTE PART PERFORMANCE OR ACCEPTANCE OF CONTRACT.

CONNECTION SIZES	
A	1 3/8" [35] DIA FIELD POWER SUPPLY HOLE
B	2 1/2" [64] DIA POWER SUPPLY KNOCKOUT
C	1 3/4" [51] DIA GAUGE ACCESS PLUG
D	7/8" [22] DIA FIELD CONTROL WIRING HOLE
E	3/4"-14 NPT CONDENSATE DRAIN
F	1/2"-14 NPT GAS CONNECTION
G	2" [51] DIA POWER SUPPLY KNOCK-OUT

THRU-THE-BASE CHART (FIELD INST)			
THESE HOLES REQUIRED FOR USE WITH ACCY KITS: CRBTMPW002A01: GAS THRU CURB CRBTMPW004A01: GAS THRU BASEPAN			
	THREADED CONDUIT SIZE	WIRE USE	REQ'D HOLE SIZES (MAX.)
W	1/2"	ACC.	7/8" [22.2]
X	1/2"	24V	7/8" [22.2]
Y	1 1/4" (002,004)	POWER	1 3/4" [44.4]
Z *	(004)	3/4" FPT GAS	1 3/4" [44.4]

\* (002) PROVIDES 3/4" FPT THRU CURB FLANGE & FITTING. HOLE SIZE: 2" [50.8]

THRU-THE-BASE CHART (FIOP)			
FOR "THRU-THE-BASEPAN" FACTORY OPTION, FITTINGS FOR ONLY X, Y, & Z ARE PROVIDED. **			
FOR BELOW LISTED MODELS, A FIELD SUPPLIED 1/2" ADAPTER IS REQUIRED BETWEEN BASE PAN FITTING AND GAS VALVE: 48FCD,S*08,09			

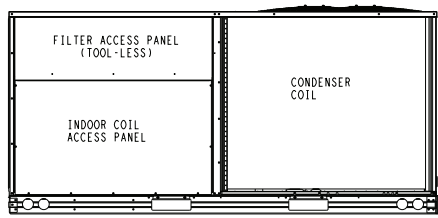

BACK

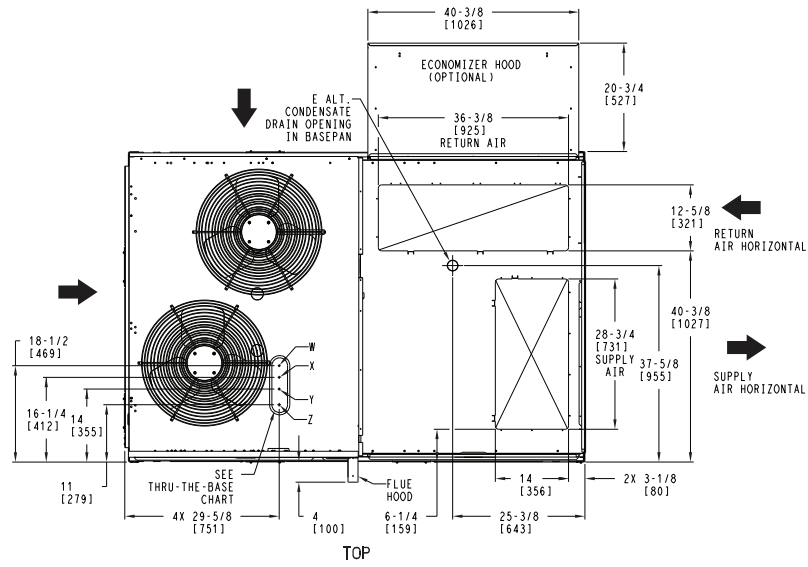

TOP

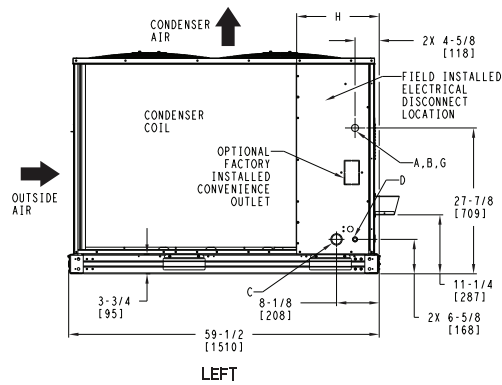

LEFT

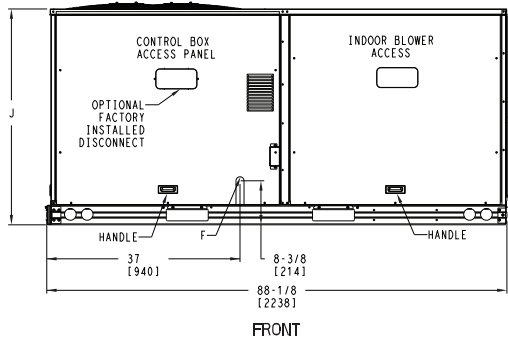

FRONT

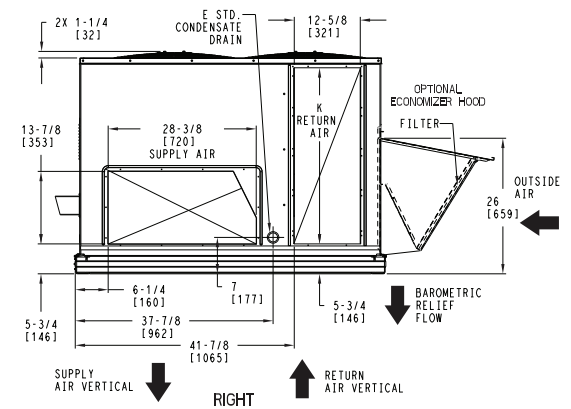

RIGHT

ITC CLASSIFICATION	SHEET	DATE	SUPERCEDES	48FC 08-12 SINGLE ZONE ELECTRICAL COOLING WITH GAS HEAT	48TM006295	REV
U.S. ECCN:NSR	1 OF 3	03/12/21	-			-



### 48FC\*\*08-12 BASE UNIT DIMENSIONS (cont)

UNIT	OUTDOOR COIL TYPE	STD. UNIT WEIGHT ***		CORNER WEIGHT (A)		CORNER WEIGHT (B)		CORNER WEIGHT (C)		CORNER WEIGHT (D)		C.G.			
		LBS.	KG.	LBS.	KG.	LBS.	KG.	LBS.	KG.	LBS.	KG.	X	Y	Z	
48FC-M08	RTPF	787	357	181	82	150	68	207	94	249	113	40	1/2 [1016]	34 1/2 [876]	19 3/8 [492]
48FC-M09	RTPF	868	394	197	89	160	73	229	104	282	128	39 1/2 [1003]	35 [889]	18 5/8 [473]	
48FC-M12	RTPF	878	398	213	97	175	80	221	100	268	121	39 7/8 [1013]	33 1/4 [841]	18 1/2 [470]	

RTPF - ROUND TUBE, PLATE FIN (COPPER/ALUM)



THIS DOCUMENT IS THE PROPERTY OF CARRIER CORPORATION AND IS DELIVERED UPON THE EXPRESS CONDITION THAT THE CONTENTS WILL NOT BE DISCLOSED OR USED WITHOUT CARRIER CORPORATION'S WRITTEN CONSENT.

SUBMISSION OF THESE DRAWINGS OR DOCUMENTS DOES NOT CONSTITUTE PART PERFORMANCE OR ACCEPTANCE OF CONTRACT.

\*\*\* STANDARD UNIT WEIGHT IS WITH LOW GAS HEAT AND WITHOUT PACKAGING. FOR OTHER OPTIONS AND ACCESSORIES, REFER TO THE PRODUCT DATA CATALOG.

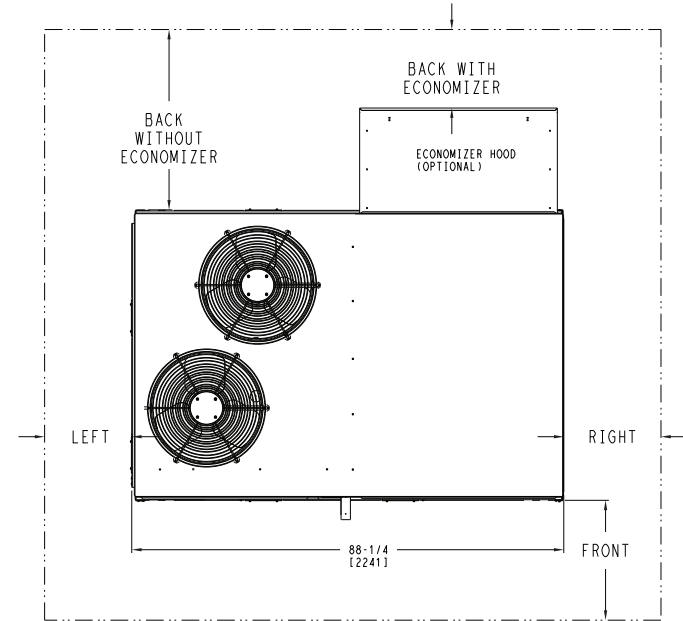
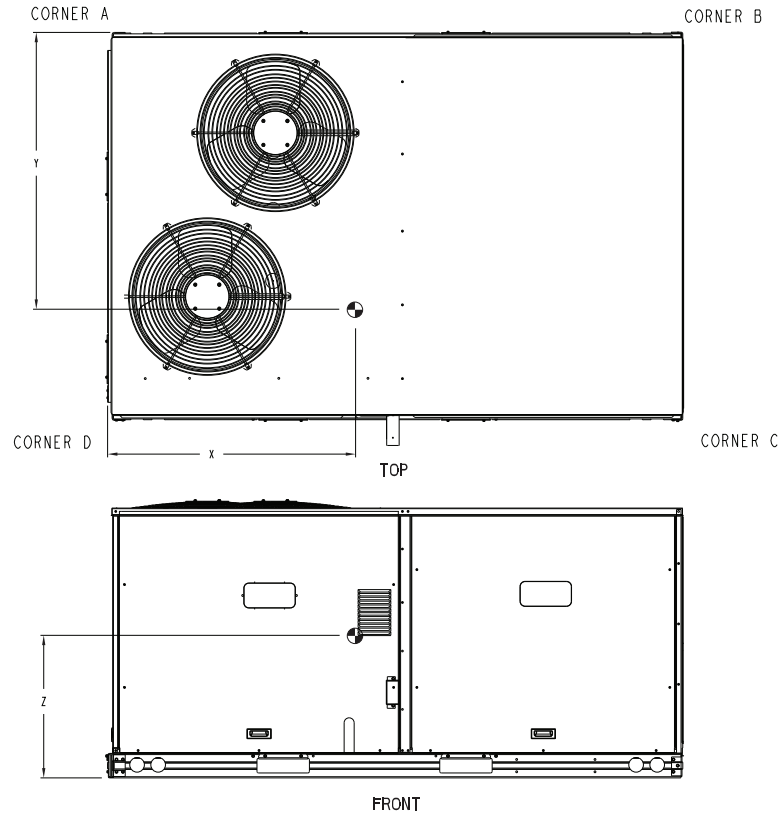

NOTE:

1. FOR ALL MINIMUM CLEARANCES LOCAL CODES OR JURISDICTIONS MAY PREVAIL.

SURFACE	SERVICE WITH:		OPERATING CLEARANCE
	CONDUCTIVE BARRIER	NONCONDUCTIVE BARRIER	
FRONT	48 [1219mm]	36 [914mm]	18 [457mm]
LEFT	48 [1219mm]	42 [1067mm]	18 [457mm]
BACK W/O ECON	48 [1219mm]	42 [1067mm]	18 [457mm]
BACK W/ECON	36 [914mm]	36 [914mm]	18 [457mm]
RIGHT	36 [914mm]	36 [914mm]	18 [457mm]
TOP	72 [1829mm]	72 [1829mm]	72 [1829mm]

ITC CLASSIFICATION	SHEET	DATE	SUPERCEDES	48FC 08-12 SINGLE ZONE ELECTRICAL COOLING WITH GAS HEAT	REV
U.S. ECCN:NSR	2 OF 3	03/12/21	-		48TM006295 -



**48FC\*\*08-12 BASE UNIT DIMENSIONS (cont)**

**Carrier** THIS DOCUMENT IS THE PROPERTY OF CARRIER CORPORATION AND IS DELIVERED UPON THE EXPRESS CONDITION THAT THE CONTENTS WILL NOT BE DISCLOSED OR USED WITHOUT CARRIER CORPORATION'S WRITTEN CONSENT. SUBMISSION OF THESE DRAWINGS OR DOCUMENTS DOES NOT CONSTITUTE PART PERFORMANCE OR ACCEPTANCE OF CONTRACT.

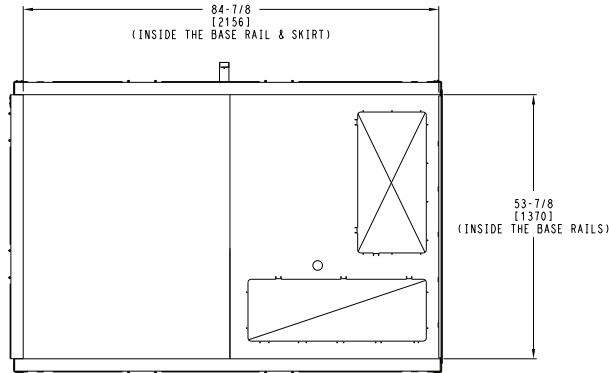
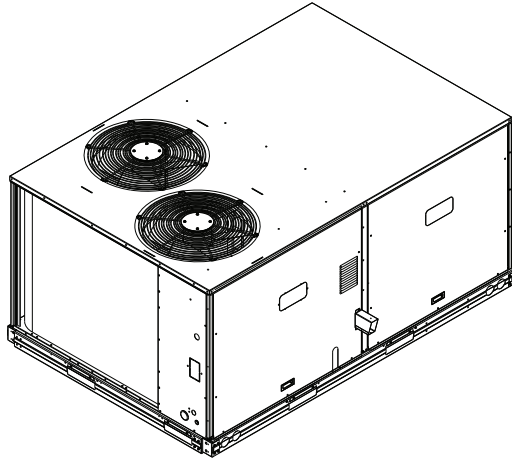

INSIDE BASERAIL DIMENSIONS  
BOTTOM

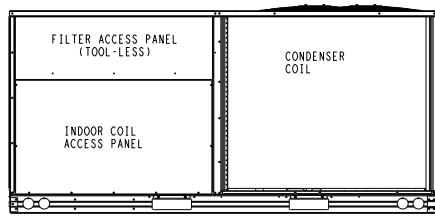
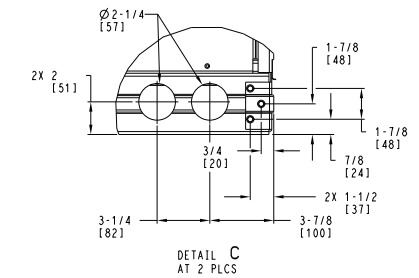
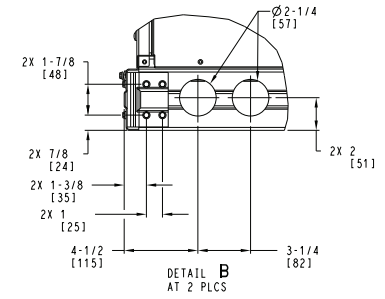

BACK

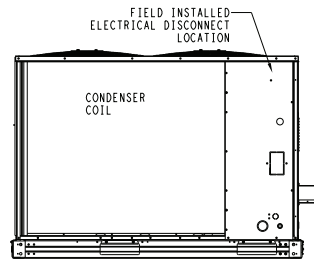

LEFT

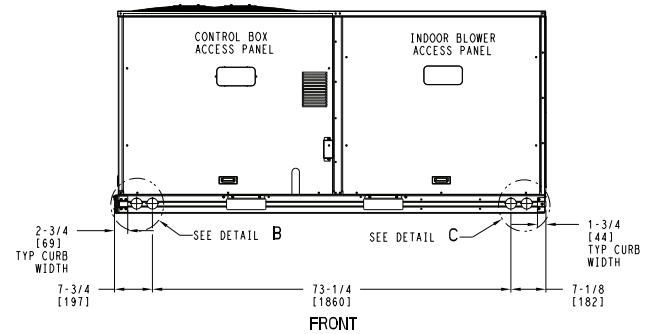

FRONT

ITC CLASSIFICATION	SHEET	DATE	SUPERCEDES	48FC 08-12 SINGLE ZONE ELECTRICAL COOLING WITH GAS HEAT	48TM006295	REV
U.S. ECCN: NSR	3 OF 3	03/12/21	-			-



### 48FC\*\*14 BASE UNIT DIMENSIONS

- NOTES:
1. DIMENSIONS ARE IN INCHES. DIMENSIONS IN [ ] ARE IN MILLIMETERS.
  2. CENTER OF GRAVITY
  3. DIRECTION OF AIR FLOW
  4. ALL VIEW DRAWN USING 3RD ANGLE

UNIT	OUTDOOR COIL TYPE	H
48FC-M14	RTPF	15 7/8 [403]
RTPF - ROUND TUBE, PLATE FIN (COPPER/ALUM)		



THIS DOCUMENT IS THE PROPERTY OF CARRIER CORPORATION AND IS DELIVERED UPON THE EXPRESS CONDITION THAT THE CONTENTS WILL NOT BE DISCLOSED OR USED WITHOUT CARRIER CORPORATION'S WRITTEN CONSENT.

SUBMISSION OF THESE DRAWINGS OR DOCUMENTS DOES NOT CONSTITUTE PART PERFORMANCE OR ACCEPTANCE OF CONTRACT.

CONNECTION SIZES	
A	1 3/8" [35] DIA FIELD POWER SUPPLY HOLE
B	2 1/2" [64] DIA POWER SUPPLY KNOCKOUT
C	1 3/4" [51] DIA GAUGE ACCESS PLUG
D	7/8" [22] DIA FIELD CONTROL WIRING HOLE
E	3/4" -14 NPT CONDENSATE DRAIN
F	3/4" -14 NPT GAS CONNECTION
G	2" [51] DIA POWER SUPPLY KNOCK-OUT

THRU-THE-BASE CHART THESE HOLES REQUIRED FOR USE CRBTPWRO2A01,00A01			
	THREADED CONDUIT SIZE	WIRE USE	REQ'D HOLE SIZES (MAX.)
W	1/2"	ACC.	7/8" [22.2]
X	1/2"	24V	7/8" [22.2]
Y	1 1/4" (002,004)	POWER	1 3/4" [44.4]
Z*	(004) 3/4" FPT	GAS	1 5/8" [41.3]
FOR "THRU-THE-BASEPAN" FACTORY OPTION, FITTINGS FOR ONLY X, Y, & Z ARE PROVIDED			
* (002) PROVIDES 3/4" FPT THRU CURB FLANGE & FITTING.			

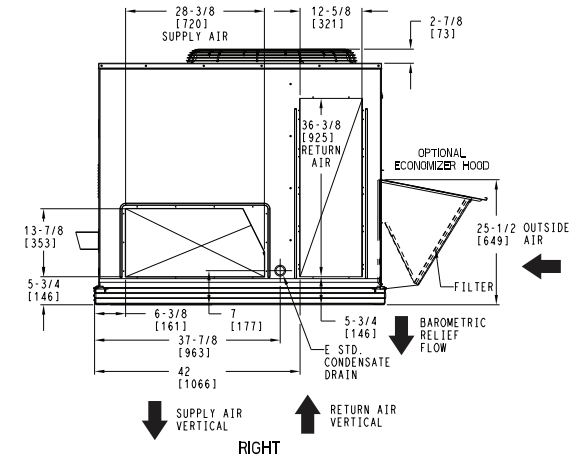
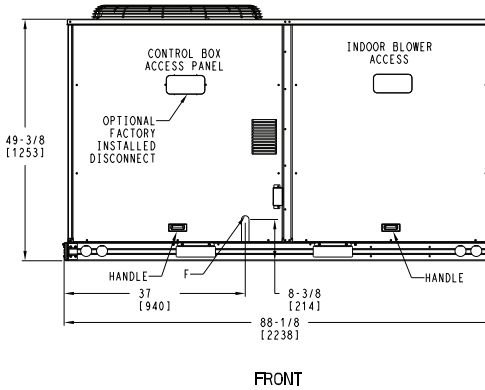
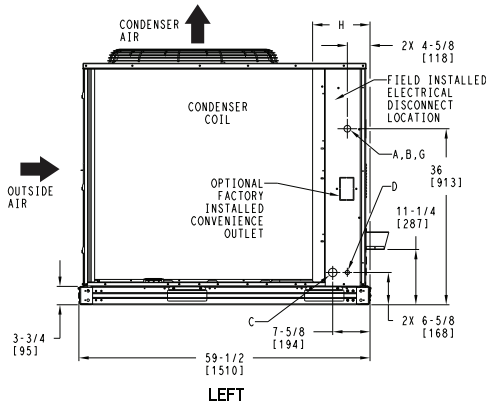
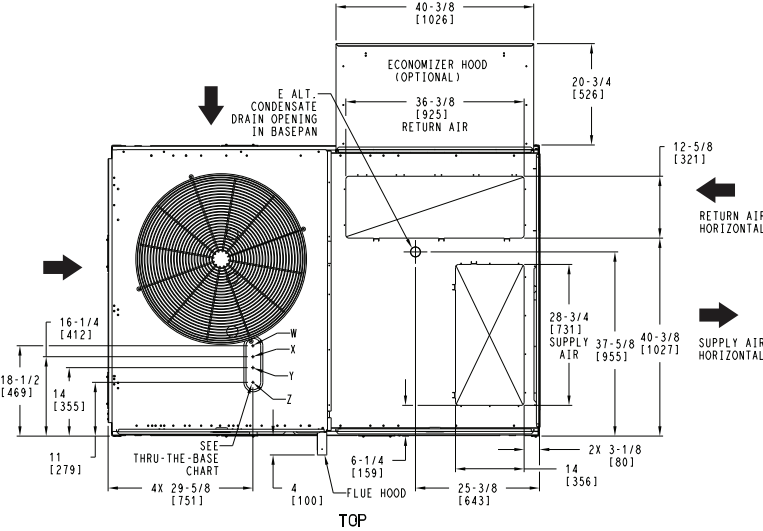
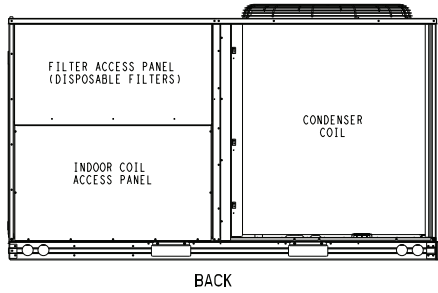

ITC CLASSIFICATION	SHEET	DATE	SUPERCEDES	48FC-14 SINGLE ZONE ELECTRICAL COOLING WITH GAS HEAT	48TM006297	REV
U.S. ECCN:NSR	1 OF 3	03/12/21	-			-



### 48FC\*\*14 BASE UNIT DIMENSIONS (cont)

**Carrier** THIS DOCUMENT IS THE PROPERTY OF CARRIER CORPORATION AND IS DELIVERED UPON THE EXPRESS CONDITION THAT THE CONTENTS WILL NOT BE DISCLOSED OR USED WITHOUT CARRIER CORPORATION'S WRITTEN CONSENT. SUBMISSION OF THESE DRAWINGS OR DOCUMENTS DOES NOT CONSTITUTE PART PERFORMANCE OR ACCEPTANCE OF CONTRACT.

UNIT	OUTDOOR COIL TYPE	STD. UNIT WEIGHT***		CORNER WEIGHT (A)		CORNER WEIGHT (B)		CORNER WEIGHT (C)		CORNER WEIGHT (D)		C.G.					
		LBS.	KG.	LBS.	KG.	LBS.	KG.	LBS.	KG.	LBS.	KG.	X	Y	Z			
48FC-M14	RTPF	1041	472	243	110	195	88	269	122	335	152	39 1/4	[997]	34 1/2	[876]	21 7/8	[556]
RTPF - ROUND TUBE, PLATE FIN (COPPER/ALUM)																	

\*\*\* STANDARD UNIT WEIGHT IS WITH LOW GAS HEAT AND WITHOUT PACKAGING. FOR OTHER OPTIONS AND ACCESSORIES, REFER TO THE PRODUCT DATA CATALOG.

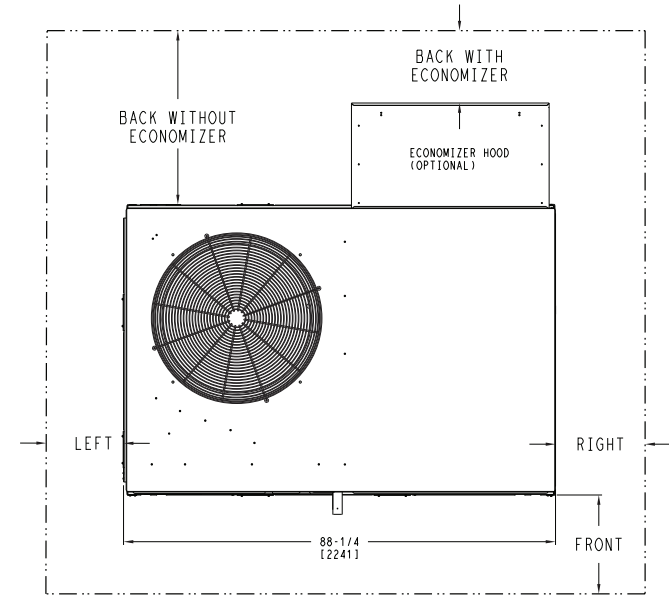
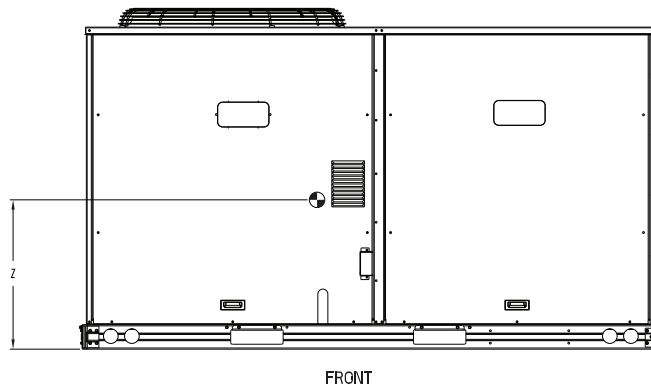
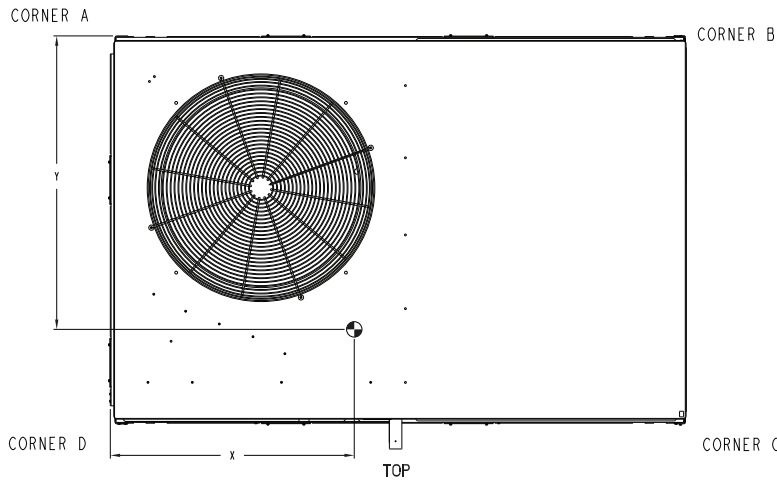

NOTE:

1. FOR ALL MINIMUM CLEARANCES LOCAL CODES OR JURISDICTIONS MAY PREVAIL.

SURFACE	SERVICE WITH:		OPERATING CLEARANCE
	CONDUCTIVE BARRIER	NONCONDUCTIVE BARRIER	
FRONT	48 [1219mm]	36 [914mm]	18 [457mm]
LEFT	48 [1219mm]	42 [1067mm]	18 [457mm]
BACK W/O ECON	48 [1219mm]	42 [1067mm]	18 [457mm]
BACK W/ECON	36 [914mm]	36 [914mm]	18 [457mm]
RIGHT	36 [914mm]	36 [914mm]	18 [457mm]
TOP	72 [1829mm]	72 [1829mm]	72 [1829mm]

ITC CLASSIFICATION	SHEET	DATE	SUPERCEDES	48FC-14 SINGLE ZONE ELECTRICAL COOLING WITH GAS HEAT	48TM006297	REV
U.S. ECCN:NSR	2 OF 3	03/12/21	-			-



### 48FC\*\*14 BASE UNIT DIMENSIONS (cont)

**Carrier** THIS DOCUMENT IS THE PROPERTY OF CARRIER CORPORATION AND IS DELIVERED UPON THE EXPRESS CONDITION THAT THE CONTENTS WILL NOT BE DISCLOSED OR USED WITHOUT CARRIER CORPORATION'S WRITTEN CONSENT. SUBMISSION OF THESE DRAWINGS OR DOCUMENTS DOES NOT CONSTITUTE PART PERFORMANCE OR ACCEPTANCE OF CONTRACT.

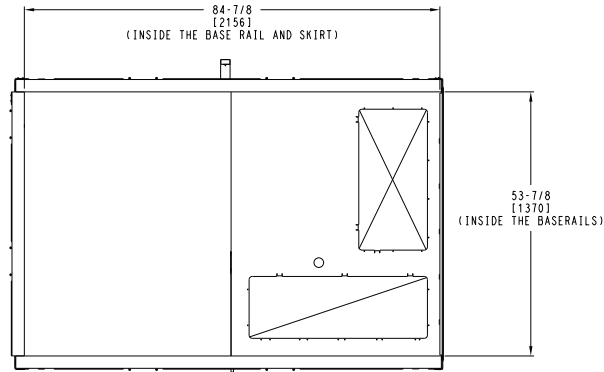
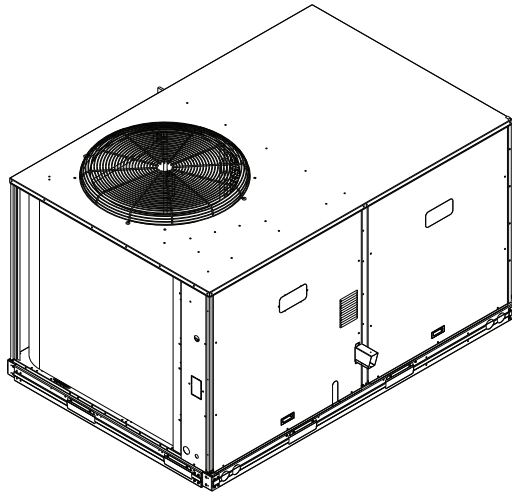

INSIDE BASERAIL DIMENSIONS  
BOTTOM

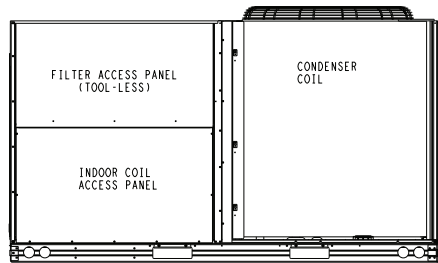
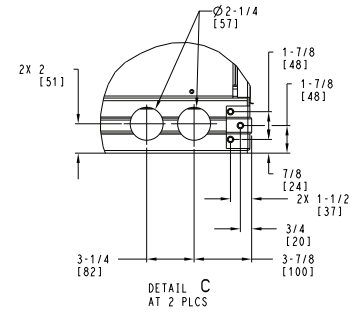
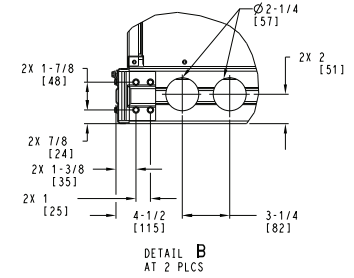

BACK

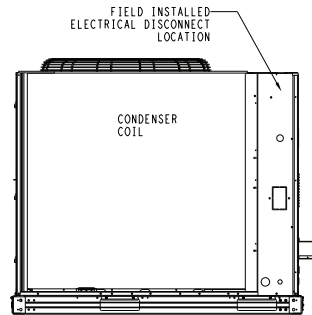

LEFT

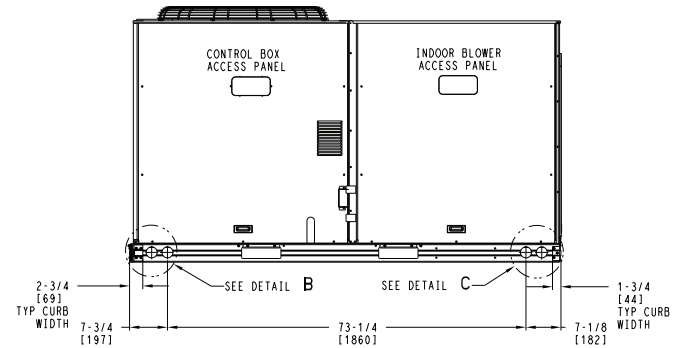

FRONT

ITC CLASSIFICATION U.S. ECCN:NSR	SHEET 3 OF 3	DATE 03/12/21	SUPERCEDES -	48FC-14 SINGLE ZONE ELECTRICAL COOLING WITH GAS HEAT	48TM006297	REV -
-------------------------------------	-----------------	------------------	-----------------	---	------------	----------





### 48FC\*\*16 BASE UNIT DIMENSIONS

- NOTES:
1. DIMENSIONS ARE IN INCHES, DIMENSIONS IN [ ] ARE IN MILLIMETERS.
  2. CENTER OF GRAVITY
  3. DIRECTION OF AIR FLOW

**Carrier** THIS DOCUMENT IS THE PROPERTY OF CARRIER CORPORATION AND IS DELIVERED UPON THE EXPRESS CONDITION THAT THE CONTENTS WILL NOT BE DISCLOSED OR USED WITHOUT CARRIER CORPORATION'S WRITTEN CONSENT. SUBMISSION OF THESE DRAWINGS OR DOCUMENTS DOES NOT CONSTITUTE PART PERFORMANCE OR ACCEPTANCE OF CONTRACT.

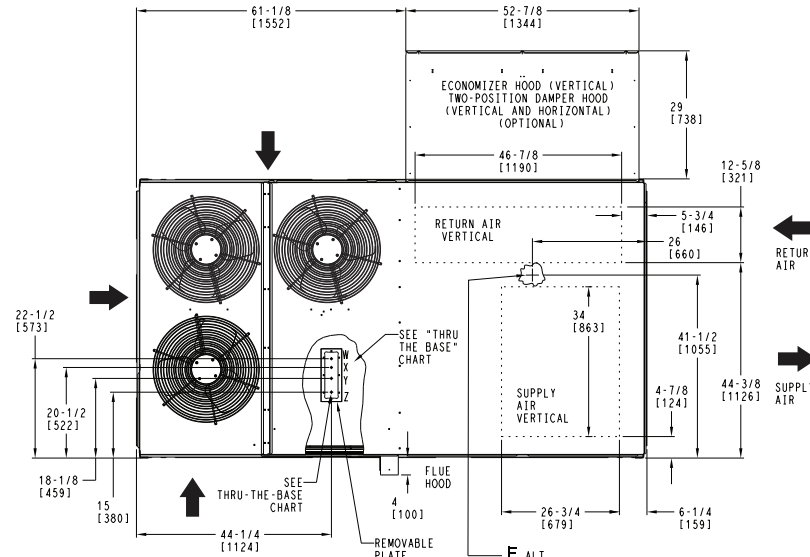
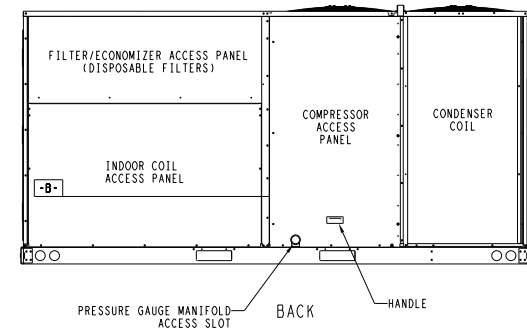

CONNECTION SIZES	
B	2 1/2" [64] DIA POWER SUPPLY HOLE
D	7/8" [22] DIA FIELD CONTROL WIRING HOLE
E	3/4"-14 NPT CONDENSATE DRAIN
F	7/8" [22] DIA FIELD CONVENIENCE OUTLET HOLE
G	3/4"-14 NPT GAS CONNECTION

THRU-THE-BASE CHART THESE HOLES REQUIRED FOR USE CRBTMPWRO05A00,006A00,007A00				
ACCESSORY NO.	W	X	Y	Z
005	1/2"	1/2"	1 1/4"	3/4" PIPE
	ACC.	24V	POWER	GAS
	7/8" [22.2]	7/8" [22.2]	1 1/2" [38.1]	1 3/4" [44.5]
	REQ'D HOLE SIZES (MAX.)			
006	1/2"	1/2"	1 1/2"	3/4" PIPE
	ACC.	24V	POWER	GAS
	7/8" [22.2]	7/8" [22.2]	2" [50.8]	1 3/4" [44.5]
	REQ'D HOLE SIZES (MAX.)			
007	1/2"	1/2"	2"	3/4" PIPE
	ACC.	24V	POWER	GAS
	7/8" [22.2]	7/8" [22.2]	2 1/2" [63.5]	1 3/4" [44.5]
	REQ'D HOLE SIZES (MAX.)			

FOR "THRU-THE-BASEPAN" FACTORY OPTION, FITTINGS FOR X & Y ARE PROVIDED AS SPECIFIED ON "006".

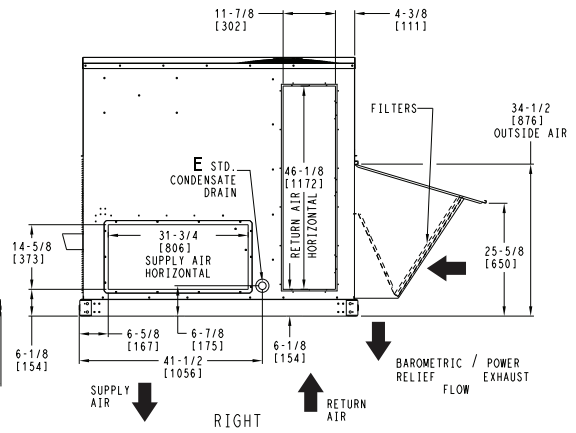
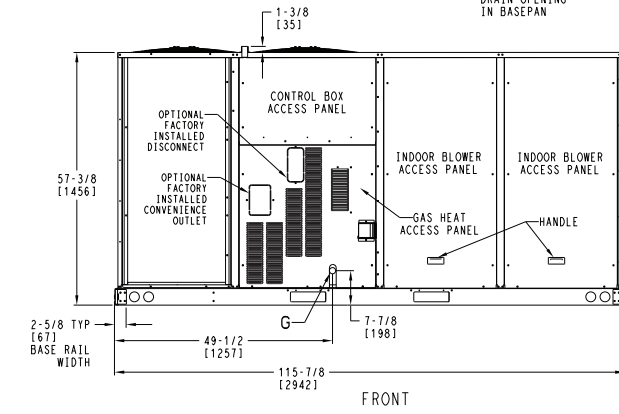
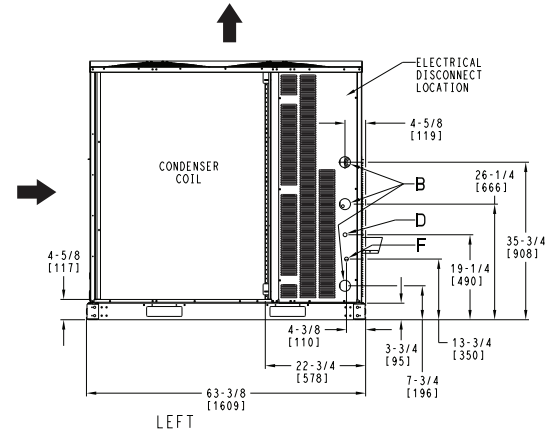

ITC CLASSIFICATION	SHEET	DATE	SUPERCEDES	48FC 16 SINGLE ZONE ELECTRICAL COOLING WITH GAS HEAT	50TM002025	REV
U.S. ECCN:NSR	1 OF 2	06/28/22	06/10/21			A



### 48FC\*\*16 BASE UNIT DIMENSIONS (cont)

UNIT	STD UNIT WEIGHT		CORNER WEIGHT (A)		CORNER WEIGHT (B)		CORNER WEIGHT (C)		CORNER WEIGHT (D)		C.G.					
	LBS.	KG.	LBS.	KG.	LBS.	KG.	LBS.	KG.	LBS.	KG.	X	Y	Z			
48FC-M16	1408	639	373	169	341	155	332	150	362	164	55 3/8	1407 1/4	31 1/4	1794 1/8	21 1/8	1537 1/8

STANDARD UNIT WEIGHT IS WITH LOW HEAT & WITHOUT PACKAGING.  
FOR OPTIONS & ACCESSORIES, REFER TO THE PRODUCT DATA CATALOG.

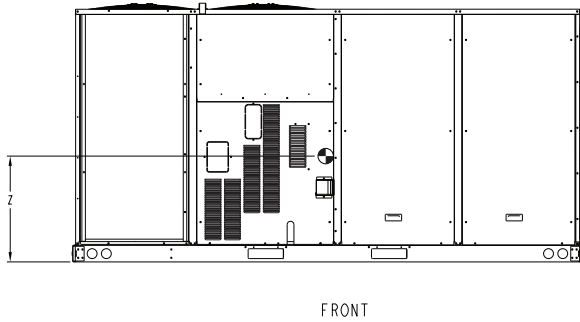
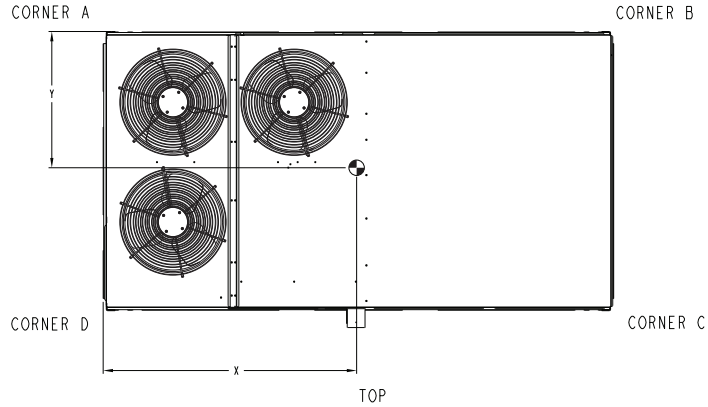

**Carrier** THIS DOCUMENT IS THE PROPERTY OF CARRIER CORPORATION AND IS DELIVERED UPON THE EXPRESS CONDITION THAT THE CONTENTS WILL NOT BE DISCLOSED OR USED WITHOUT CARRIER CORPORATION'S WRITTEN CONSENT. SUBMISSION OF THESE DRAWINGS OR DOCUMENTS DOES NOT CONSTITUTE PART PERFORMANCE OR ACCEPTANCE OF CONTRACT.

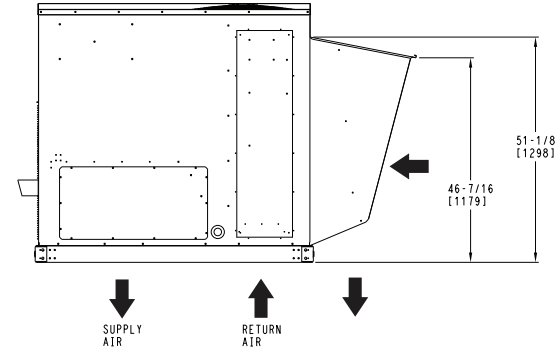
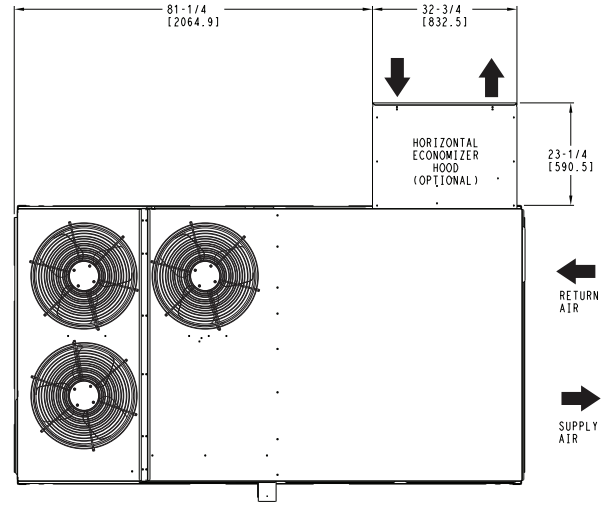

**HORIZONTAL ECONOMIZER**

ITC CLASSIFICATION U.S. ECCN:NSR	SHEET 2 OF 2	DATE 06/28/22	SUPERCEDES 06/10/21	48FC 16 SINGLE ZONE ELECTRICAL COOLING WITH GAS HEAT	50TM002025	REV A
-------------------------------------	-----------------	------------------	------------------------	---	------------	----------



## 48FC\*\*16 BASE UNIT DIMENSIONS – CLEARANCES

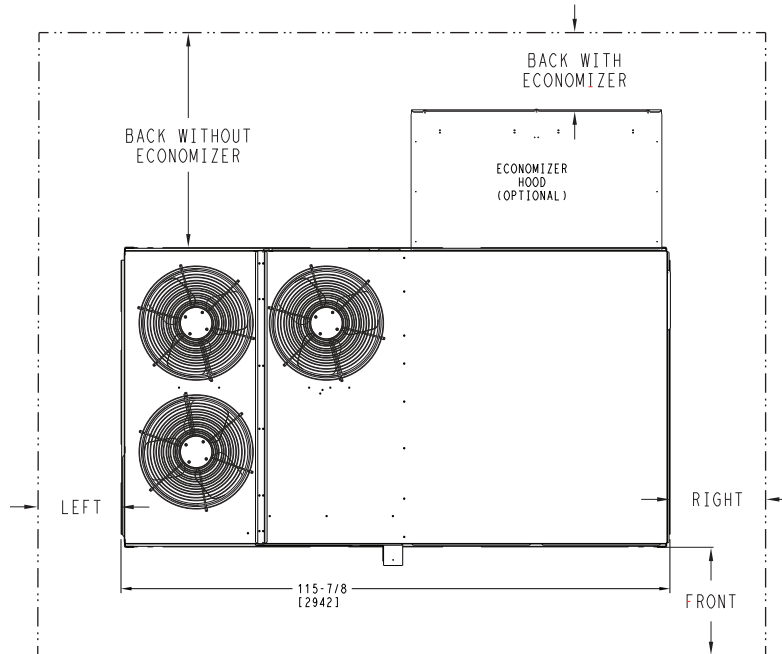

### CLEARANCE<sup>a, b</sup>

SURFACE	Service with Conductive Barrier	Service with Non-conductive Barrier	Operating Clearance
FRONT	48 in. (1219 mm)	36 in. (914 mm)	18 in. (457 mm)
LEFT	48 in. (1219 mm)	42 in. (1067 mm)	18 in. (457 mm)
BACK W/O ECONOMIZER	48 in. (1219 mm)	42 in. (1067 mm)	18 in. (457 mm)
BACK W/ ECONOMIZER	36 in. (914 mm)	36 in. (914 mm)	18 in. (457 mm)
RIGHT	36 in. (914 mm)	36 in. (914 mm)	18 in. (457 mm)
TOP	72 in. (1829 mm)	72 in. (1829 mm)	72 in. (1829 mm)

NOTE(S):

- a. For all minimum clearances local codes or jurisdictions may prevail.
- b. See page 20 for 48FC 08-12 clearances. See page 23 for 48FC 14 clearances.

### 50FC\*\*08\*12 BASE UNIT DIMENSIONS

- NOTES:
1. DIMENSIONS ARE IN INCHES, DIMENSIONS IN [ ] ARE IN MILLIMETERS.
  2. CENTER OF GRAVITY
  3. DIRECTION OF AIR FLOW
  4. ALL VIEW DRAWN USING 3RD ANGLE

UNIT	OUTDOOR COIL TYPE	J	K	H
50FC-M08	RTPF	41 1/4 [1048]	33 3/4 [857]	15 7/8 [403]
50FC-M09	RTPF	49 3/8 [1253]	36 3/8 [925]	15 7/8 [403]
50FC-M12	RTPF	49 3/8 [1253]	36 3/8 [925]	15 7/8 [403]

RTPF - ROUND TUBE, PLATE FIN (COPPER/ALUM)

**Carrier** THIS DOCUMENT IS THE PROPERTY OF CARRIER CORPORATION AND IS DELIVERED UPON THE EXPRESS CONDITION THAT THE CONTENTS WILL NOT BE DISCLOSED OR USED WITHOUT CARRIER CORPORATION'S WRITTEN CONSENT. SUBMISSION OF THESE DRAWINGS OR DOCUMENTS DOES NOT CONSTITUTE PART PERFORMANCE OR ACCEPTANCE OF CONTRACT.

CONNECTION SIZES	
A	1 3/8" [35] DIA FIELD POWER SUPPLY HOLE
B	2 1/2" [64] DIA POWER SUPPLY KNOCKOUT
C	1 3/4" [51] DIA GAUGE ACCESS PLUG
D	7/8" [22] DIA FIELD CONTROL WIRING HOLE
E	3/4"-14 NPT CONDENSATE DRAIN
G	2" [51] DIA POWER SUPPLY KNOCK-OUT

THRU-THE-BASE CHART (FIELD INST)			
THESE HOLES REQUIRED FOR USE WITH ACCY KITS: CRBTMPNR002A01			
	THREADED CONDUIT SIZE	WIRE USE	REQ'D HOLE SIZES (MAX.)
W	1/2"	ACC.	7/8" [22.2]
X	1/2"	24V	7/8" [22.2]
Y	1 1/4" [002]	POWER	1 3/4" [44.4]

THRU-THE-BASE CHART (FIOF)			
FOR "THRU-THE-BASEPAN" FACTORY OPTION, FITTINGS FOR ONLY X & Y ARE PROVIDED:			
(1) 1/2" & (1) 1 1/4" ELECTRICAL FITTINGS.			

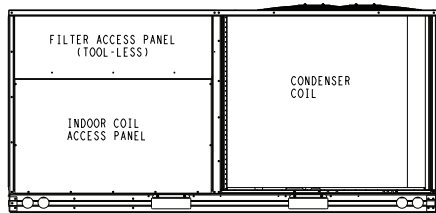

BACK

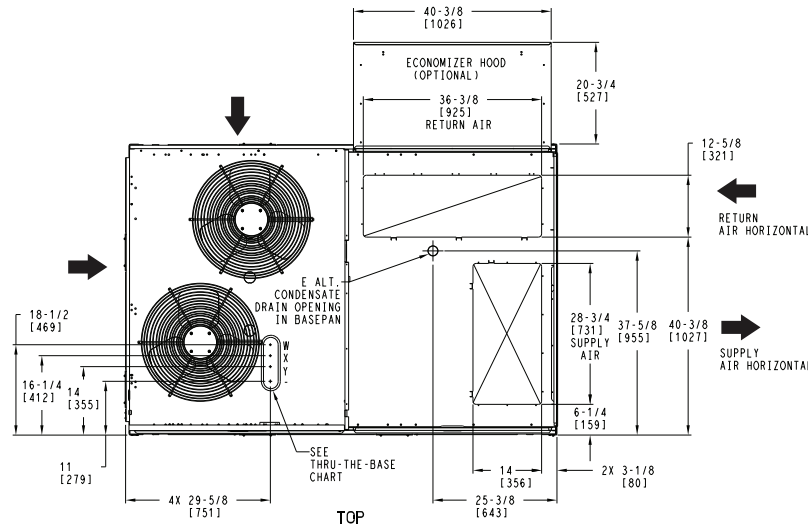

TOP

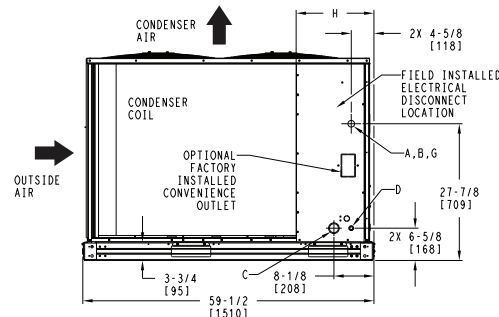

LEFT

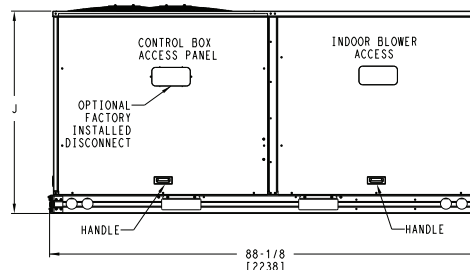

FRONT

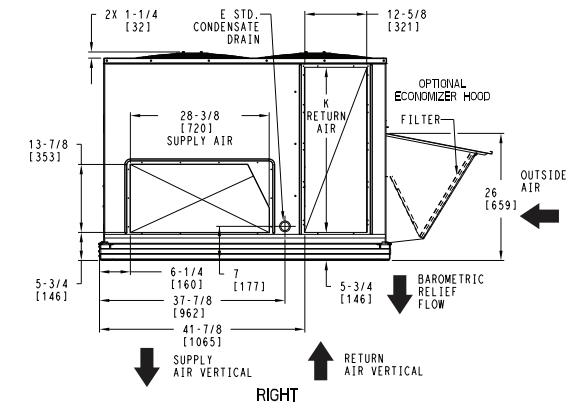

RIGHT

ITC CLASSIFICATION	SHEET	DATE	SUPERCEDES	DESCRIPTION	REV
U.S. ECCN:NSR	1 OF 3	03/12/21	-	50FC 08-12 SINGLE ZONE ELECTRICAL COOLING WITH ELECTRIC HEAT	48TM006296



### 50FC\*\*08-12 BASE UNIT DIMENSIONS (cont)

**Carrier** THIS DOCUMENT IS THE PROPERTY OF CARRIER CORPORATION AND IS DELIVERED UPON THE EXPRESS CONDITION THAT THE CONTENTS WILL NOT BE DISCLOSED OR USED WITHOUT CARRIER CORPORATION'S WRITTEN CONSENT. SUBMISSION OF THESE DRAWINGS OR DOCUMENTS DOES NOT CONSTITUTE PART PERFORMANCE OR ACCEPTANCE OF CONTRACT.

UNIT	OUTDOOR COIL TYPE	STD. UNIT WEIGHT ***		CORNER WEIGHT (A)		CORNER WEIGHT (B)		CORNER WEIGHT (C)		CORNER WEIGHT (D)		C.G.		
		LBS.	KG.	LBS.	KG.	LBS.	KG.	LBS.	KG.	LBS.	KG.	X	Y	Z
50FC-M08	RTPF	743	337	170	77	142	64	196	89	235	107	40	34 1/2	20
50FC-M09	RTPF	805	365	196	89	251	114	201	91	157	71	49 1/2	26 1/2	19 1/8
50FC-M12	RTPF	815	370	198	90	254	115	204	92	159	72	49 1/2	26 1/2	19 1/8

RTPF - ROUND TUBE, PLATE FIN (COPPER/ALUM)

\*\*\* STANDARD UNIT WEIGHT IS WITHOUT ELECTRIC HEAT AND WITHOUT PACKAGING. FOR OTHER OPTIONS AND ACCESSORIES, REFER TO THE PRODUCT DATA CATALOG.

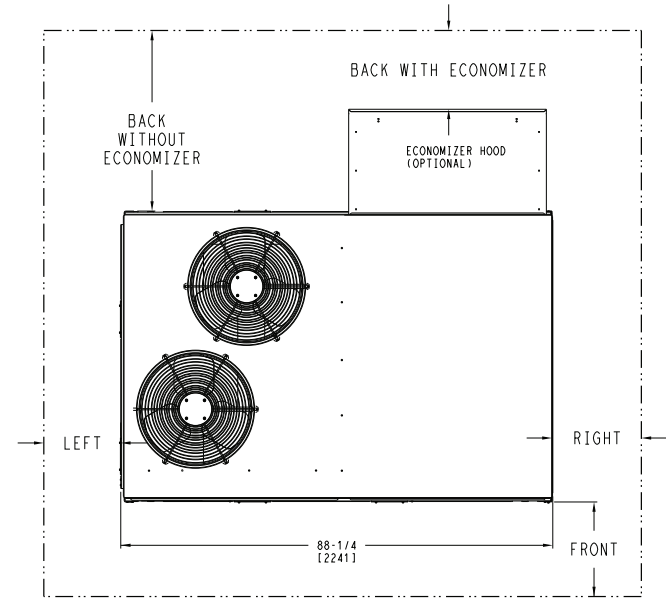
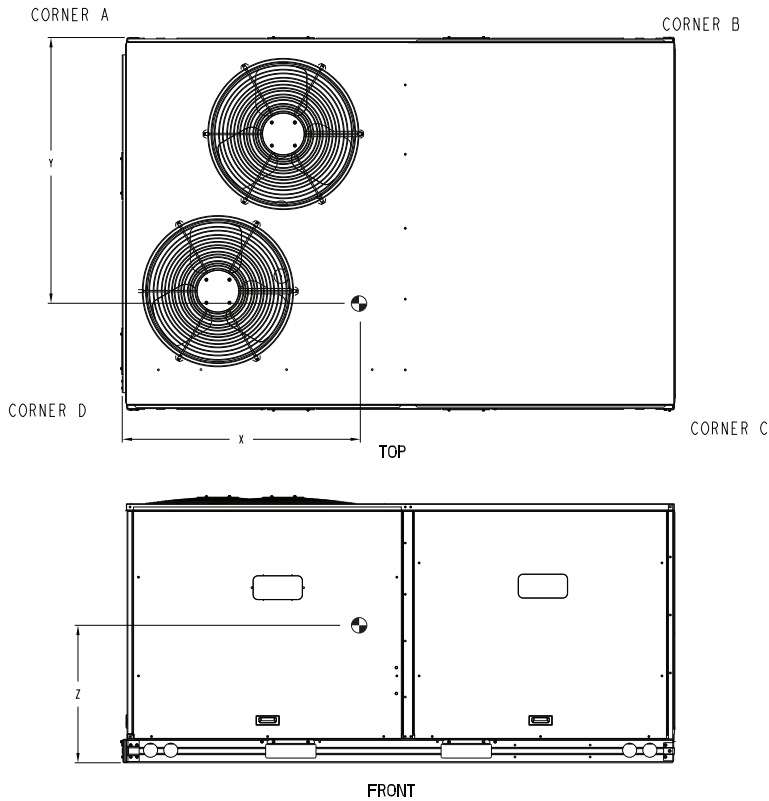

NOTE:  
1. FOR ALL MINIMUM CLEARANCES LOCAL CODES OR JURISDICTIONS MAY PREVAIL.

SURFACE	CLEARANCE		OPERATING CLEARANCE
	SERVICE WITH: CONDUCTIVE BARRIER	SERVICE WITH: NONCONDUCTIVE BARRIER	
FRONT	48 [1219mm]	36 [914mm]	18 [457mm]
LEFT	48 [1219mm]	42 [1067mm]	18 [457mm]
BACK W/O ECON	48 [1219mm]	42 [1067mm]	18 [457mm]
BACK W/ECON	36 [914mm]	36 [914mm]	18 [457mm]
RIGHT	36 [914mm]	36 [914mm]	18 [457mm]
TOP	72 [1829mm]	72 [1829mm]	72 [1829mm]

ITC CLASSIFICATION U.S. ECCN:NSR	SHEET 2 OF 3	DATE 03/12/21	SUPERCEDES -	50FC 08-12 SINGLE ZONE ELECTRICAL COOLING WITH ELECTRIC HEAT	48TM006296	REV -
-------------------------------------	-----------------	------------------	-----------------	--	------------	----------



### 50FC\*\*08-12 BASE UNIT DIMENSIONS (cont)

**Carrier** THIS DOCUMENT IS THE PROPERTY OF CARRIER CORPORATION AND IS DELIVERED UPON THE EXPRESS CONDITION THAT THE CONTENTS WILL NOT BE DISCLOSED OR USED WITHOUT CARRIER CORPORATION'S WRITTEN CONSENT. SUBMISSION OF THESE DRAWINGS OR DOCUMENTS DOES NOT CONSTITUTE PART PERFORMANCE OR ACCEPTANCE OF CONTRACT.

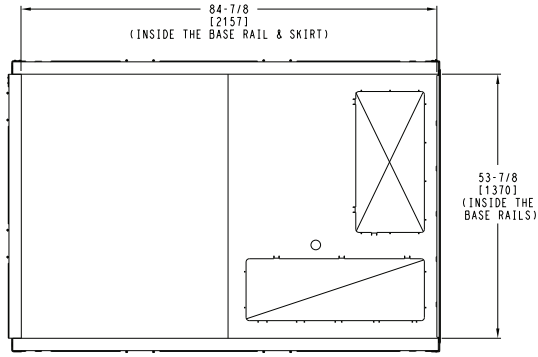
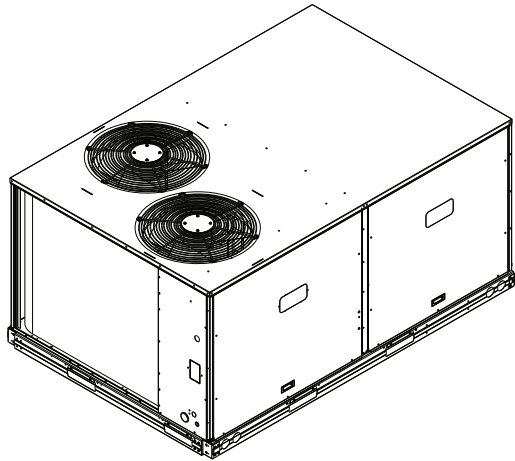

INSIDE BASERAIL DIMENSIONS  
BOTTOM

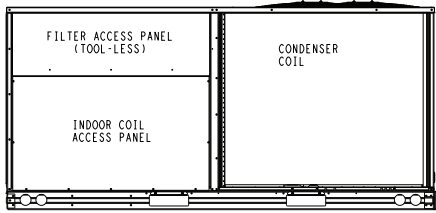
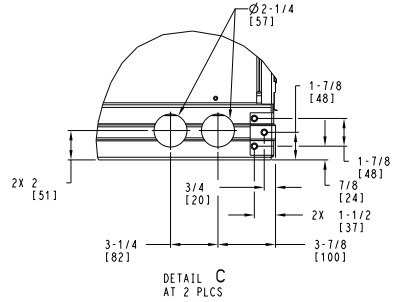
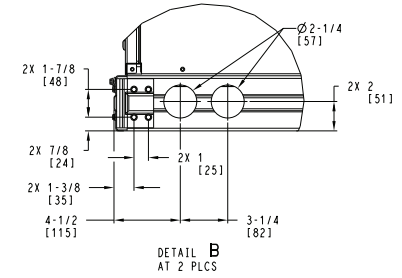

BACK

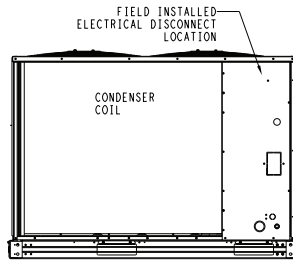

LEFT

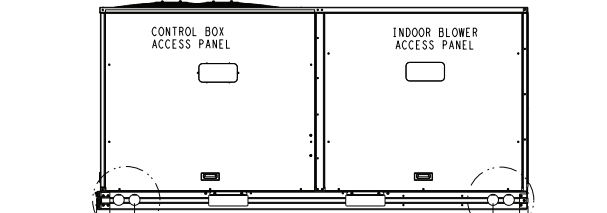

FRONT

ITC CLASSIFICATION	SHEET	DATE	SUPERCEDES	50FC 08-12 SINGLE ZONE ELECTRICAL COOLING WITH ELECTRIC HEAT	48TM006296	REV
U.S. ECCN:NSR	3 OF 3	03/12/21	-			-



### 50FC\*\*14 BASE UNIT DIMENSIONS

- NOTES:
1. DIMENSIONS ARE IN INCHES, DIMENSIONS IN [ ] ARE IN MILLIMETERS.
  2. CENTER OF GRAVITY
  3. DIRECTION OF AIR FLOW
  4. ALL VIEW DRAWN USING 3RD ANGLE

**Carrier** THIS DOCUMENT IS THE PROPERTY OF CARRIER CORPORATION AND IS DELIVERED UPON THE EXPRESS CONDITION THAT THE CONTENTS WILL NOT BE DISCLOSED OR USED WITHOUT CARRIER CORPORATION'S WRITTEN CONSENT. SUBMISSION OF THESE DRAWINGS OR DOCUMENTS DOES NOT CONSTITUTE PART PERFORMANCE OR ACCEPTANCE OF CONTRACT.

UNIT	OUTDOOR COIL TYPE	H
50FC-M14	RTPF	15 7/8 [403]
RTPF - ROUND TUBE, PLATE FIN (COPPER/ALUM)		

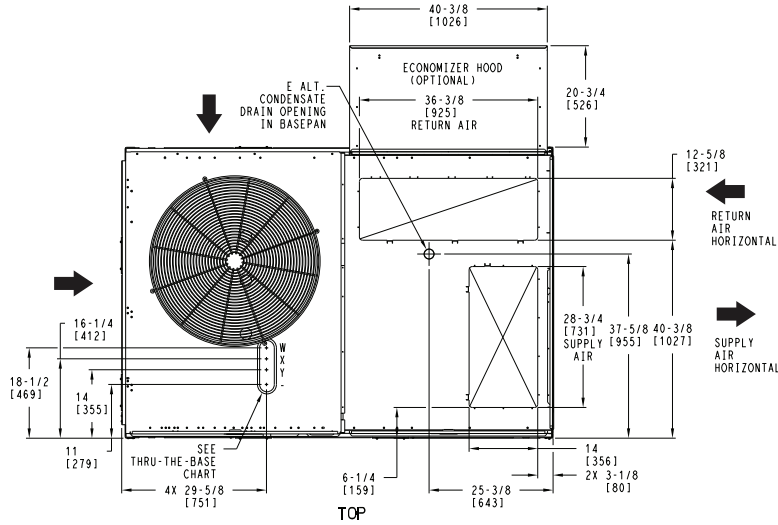
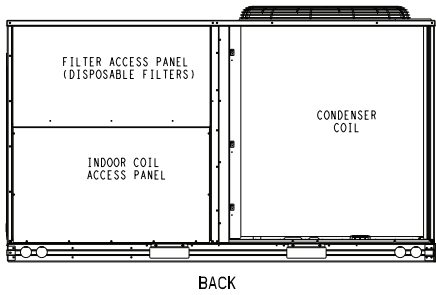

CONNECTION SIZES	
A	1 3/8" [35] DIA FIELD POWER SUPPLY HOLE
B	2 1/2" [64] DIA POWER SUPPLY KNOCKOUT
C	1 3/4" [51] DIA GAUGE ACCESS PLUG
D	7/8" [22] DIA FIELD CONTROL WIRING HOLE
E	3/4"-14 NPT CONDENSATE DRAIN
G	2" [51] DIA POWER SUPPLY KNOCK-OUT

THRU-THE-BASE CHART THESE HOLES REQUIRED FOR USE CRBTMPWR002A01			
	THREADED CONDUIT SIZE	WIRE USE	REQ'D HOLE SIZES (MAX.)
W	1/2"	ACC.	7/8" [22.2]
X	1/2"	24V	7/8" [22.2]
Y	1 1/4" [002]	POWER	1 3/4" [44.4]

FOR "THRU-THE-BASEPAN" FACTORY OPTION, FITTINGS FOR ONLY X & Y ARE PROVIDED

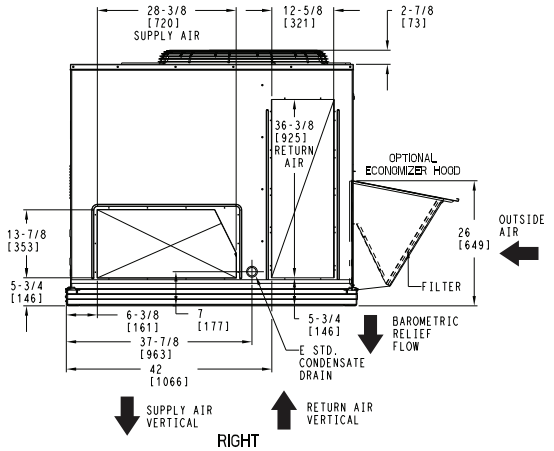
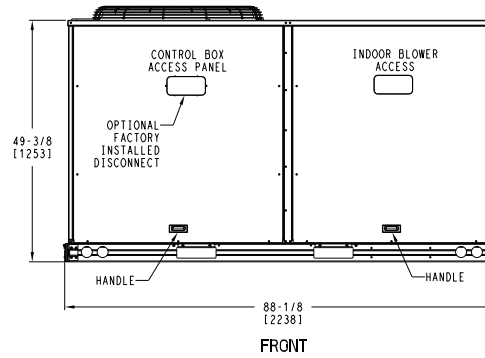
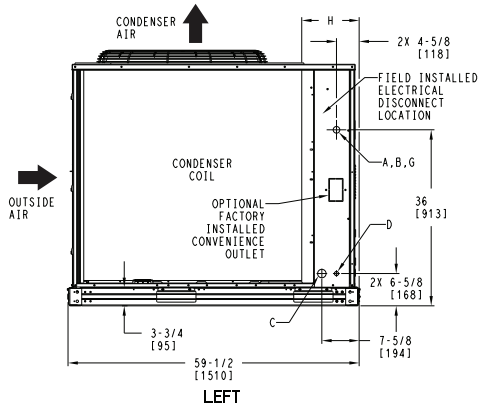

ITC CLASSIFICATION	SHEET	DATE	SUPERCEDES	50FC-14 SINGLE ZONE ELECTRICAL COOLING WITH ELECTRIC HEAT	48TM006298	REV
U.S. ECCN:NSR	1 OF 3	03/12/21	-			-



### 50FC\*\*14 BASE UNIT DIMENSIONS (cont)

**Carrier** THIS DOCUMENT IS THE PROPERTY OF CARRIER CORPORATION AND IS DELIVERED UPON THE EXPRESS CONDITION THAT THE CONTENTS WILL NOT BE DISCLOSED OR USED WITHOUT CARRIER CORPORATION'S WRITTEN CONSENT. SUBMISSION OF THESE DRAWINGS OR DOCUMENTS DOES NOT CONSTITUTE PART PERFORMANCE OR ACCEPTANCE OF CONTRACT.

UNIT	OUTDOOR COIL TYPE	STD. UNIT WEIGHT***		CORNER WEIGHT (A)		CORNER WEIGHT (B)		CORNER WEIGHT (C)		CORNER WEIGHT (D)		C.G.					
		LBS.	KG.	LBS.	KG.	LBS.	KG.	LBS.	KG.	LBS.	KG.	X	Y	Z			
50FC-M14	RTPF	978	444	234	106	300	136	249	113	195	88	49 1/2	[1257]	27	[686]	20 1/2	[521]

RTPF - ROUND TUBE, PLATE FIN (COPPER/ALUM)

\*\*\* STANDARD UNIT WEIGHT IS WITHOUT ELECTRIC HEAT AND WITHOUT PACKAGING. FOR OTHER OPTIONS AND ACCESSORIES, REFER TO THE PRODUCT DATA CATALOG.

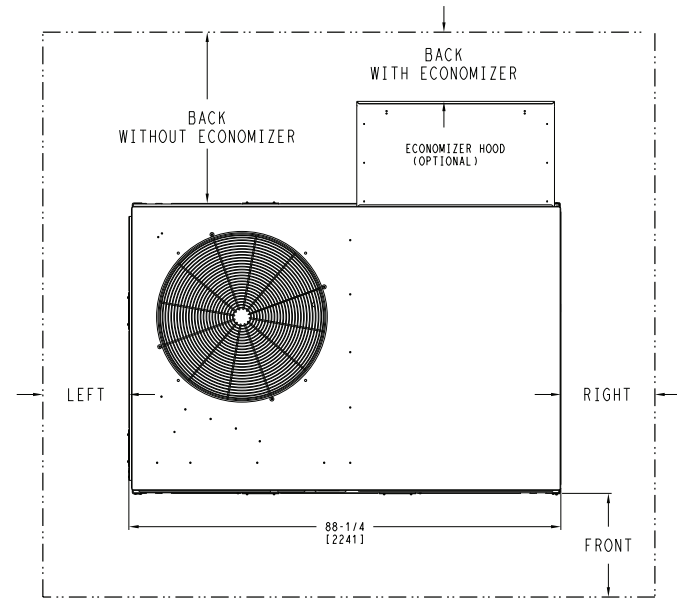
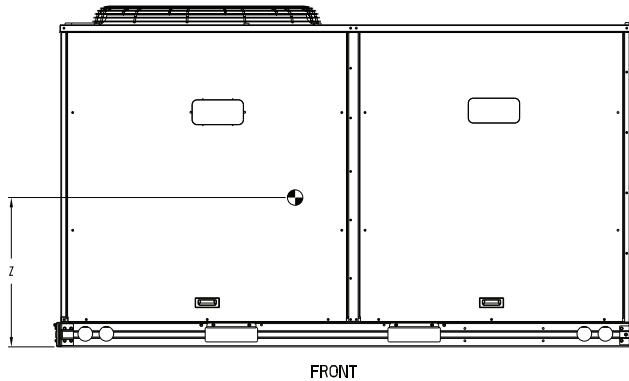
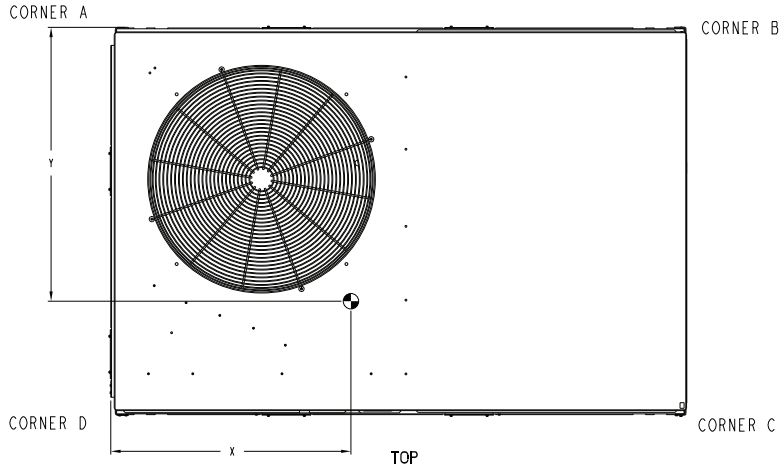

NOTE:

1. FOR ALL MINIMUM CLEARANCES LOCAL CODES OR JURISDICTIONS MAY PREVAIL.

SURFACE	SERVICE WITH:		OPERATING CLEARANCE
	CONDUCTIVE BARRIER	NONCONDUCTIVE BARRIER	
FRONT	48 [1219mm]	36 [914mm]	18 [457mm]
LEFT	48 [1219mm]	42 [1067mm]	18 [457mm]
BACK W/O ECON	48 [1219mm]	42 [1067mm]	18 [457mm]
BACK W/ECON	36 [914mm]	36 [914mm]	18 [457mm]
RIGHT	36 [914mm]	36 [914mm]	18 [457mm]
TOP	72 [1829mm]	72 [1829mm]	72 [1829mm]

ITC CLASSIFICATION U.S. ECCN:NSR	SHEET 2 OF 3	DATE 03/12/21	SUPERCEDES -	50FC-14 SINGLE ZONE ELECTRICAL COOLING WITH ELECTRIC HEAT	48TM006298	REV -
-------------------------------------	-----------------	------------------	-----------------	---	------------	----------





**50FC\*\*14 BASE UNIT DIMENSIONS (cont)**

**Carrier** THIS DOCUMENT IS THE PROPERTY OF CARRIER CORPORATION AND IS DELIVERED UPON THE EXPRESS CONDITION THAT THE CONTENTS WILL NOT BE DISCLOSED OR USED WITHOUT CARRIER CORPORATION'S WRITTEN CONSENT. SUBMISSION OF THESE DRAWINGS OR DOCUMENTS DOES NOT CONSTITUTE PART PERFORMANCE OR ACCEPTANCE OF CONTRACT.

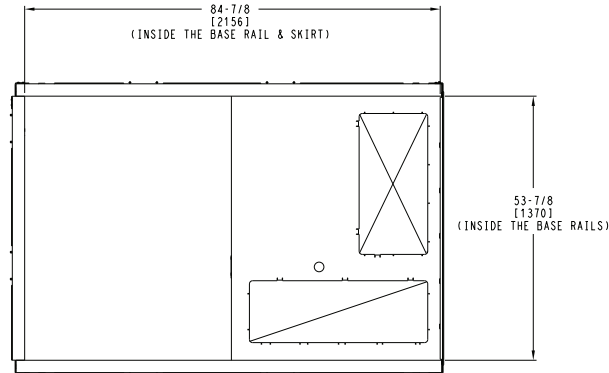
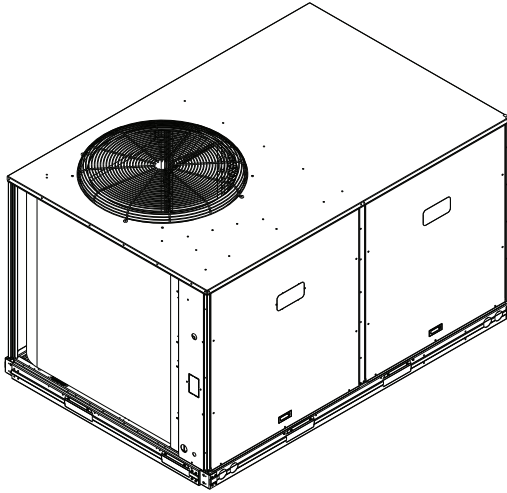

INSIDE BASERAIL DIMENSIONS  
BOTTOM

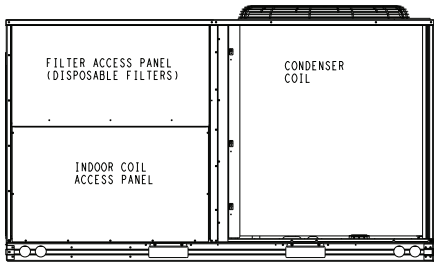
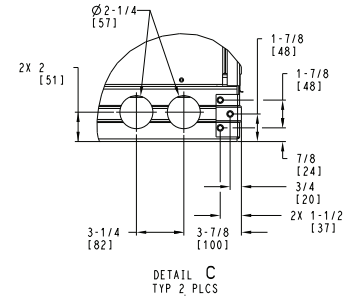
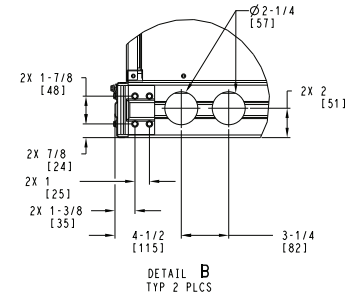

BACK

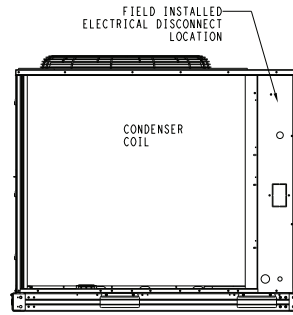

LEFT

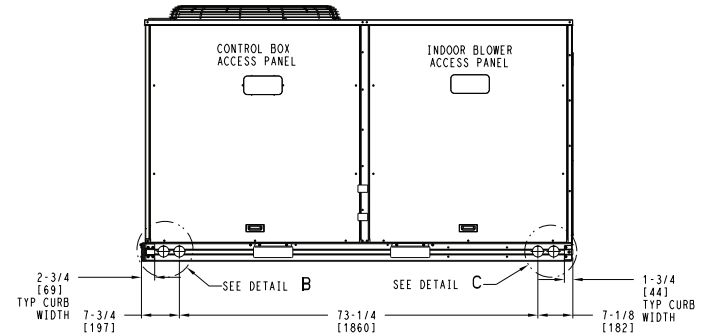

FRONT

ITC CLASSIFICATION U.S. ECCN:NSR	SHEET 3 OF 3	DATE 03/12/21	SUPERCEDES -	50FC-14 SINGLE ZONE ELECTRICAL COOLING WITH ELECTRIC HEAT	48TM006298	REV -
-------------------------------------	-----------------	------------------	-----------------	---	------------	----------



### 50FC\*\*16 BASE UNIT DIMENSIONS

- NOTES:
1. DIMENSIONS ARE IN INCHES, DIMENSIONS IN [ ] ARE IN MILLIMETERS.
  2. CENTER OF GRAVITY
  3. DIRECTION OF AIR FLOW



THIS DOCUMENT IS THE PROPERTY OF CARRIER CORPORATION AND IS DELIVERED UPON THE EXPRESS CONDITION THAT THE CONTENTS WILL NOT BE DISCLOSED OR USED WITHOUT CARRIER CORPORATION'S WRITTEN CONSENT.

SUBMISSION OF THESE DRAWINGS OR DOCUMENTS DOES NOT CONSTITUTE PART PERFORMANCE OR ACCEPTANCE OF CONTRACT.

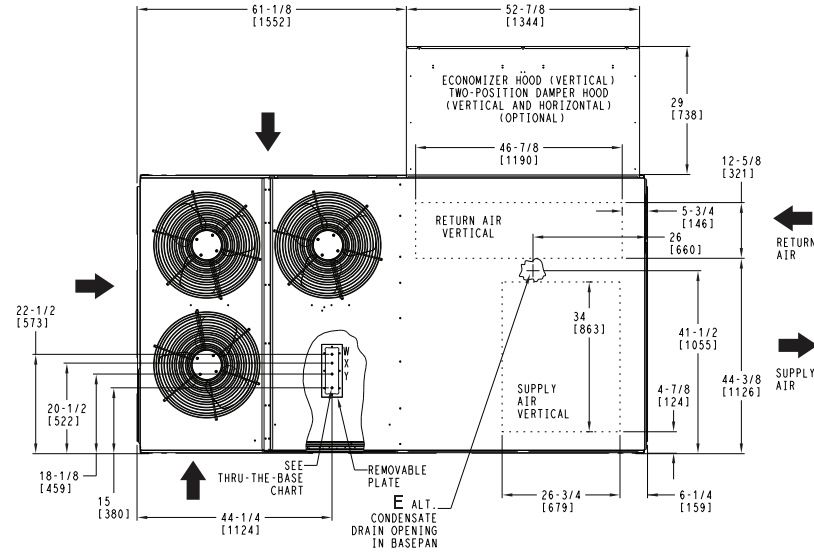
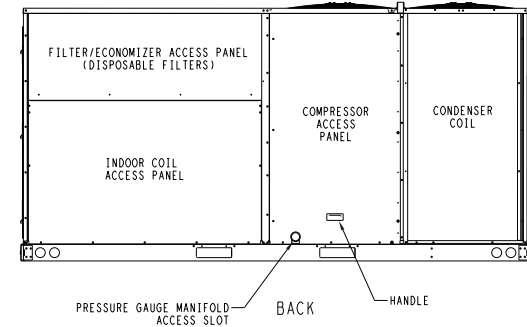

CONNECTION SIZES	
B	2 1/2" [64] DIA POWER SUPPLY HOLE
D	7/8" [22] DIA FIELD CONTROL WIRING HOLE
E	3/4"-14 NPT CONDENSATE DRAIN
F	7/8" [22] DIA FIELD CONVENIENCE OUTLET HOLE

THRU-THE-BASE CHART THESE HOLES REQUIRED FOR USE CRBTMPWRO05A00, 006A00, 007A00				
ACCESSORY NO.		THREADED CONDUIT SIZE	WIRE USE	REQ'D HOLE SIZES (MAX.)
005	W	1/2"	ACC.	7/8" [22.2]
	X	1/2"	24V	7/8" [22.2]
	Y	1 1/4"	POWER	1 1/2" [38.1]
006	W	1/2"	ACC.	7/8" [22.2]
	X	1/2"	24V	7/8" [22.2]
	Y	1 1/2"	POWER	2" [50.8]
007	W	1/2"	ACC.	7/8" [22.2]
	X	1/2"	24V	7/8" [22.2]
	Y	2"	POWER	2 1/2" [63.5]

FOR "THRU-THE-BASEPAN" FACTORY OPTION, FITTINGS FOR X & Y ARE PROVIDED AS SPECIFIED ON "006".

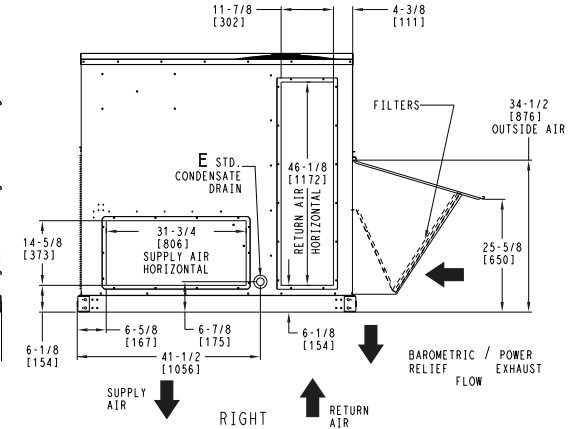
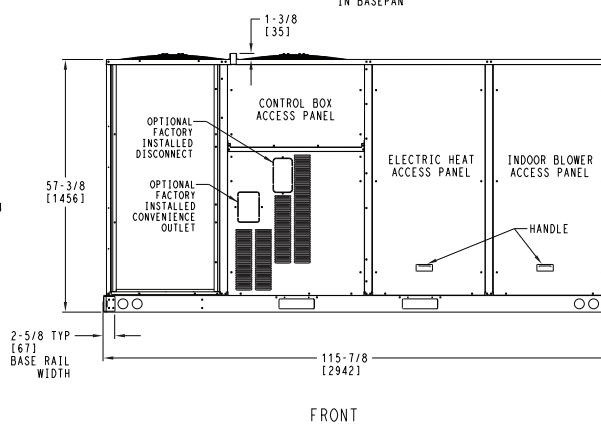
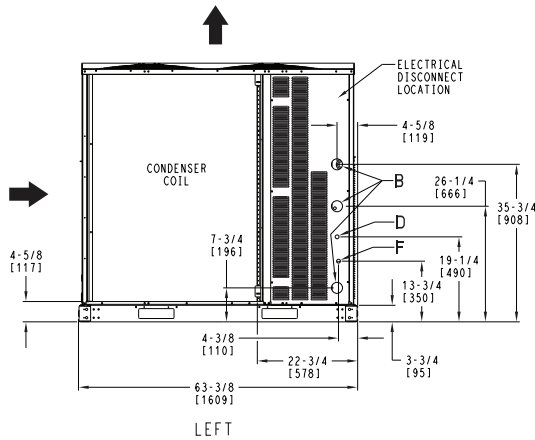

ITC CLASSIFICATION	SHEET	DATE	SUPERCEDES	50FC 16 SINGLE ZONE ELECTRICAL COOLING WITH ELECTRIC HEAT	50TM002026	REV
U.S. ECCN:NSR	1 OF 2	06/10/21	-			-



**50FC\*\*16 BASE UNIT DIMENSIONS (cont)**

UNIT	STD UNIT WEIGHT		CORNER WEIGHT (A)		CORNER WEIGHT (B)		CORNER WEIGHT (C)		CORNER WEIGHT (D)		C.G.		
	LBS.	KG.	LBS.	KG.	LBS.	KG.	LBS.	KG.	LBS.	KG.	X	Y	Z
50FC-M16	1325	601	370	168	312	142	294	133	349	158	53 [1345]	30 3/4 [781]	22 [559]

STANDARD UNIT WEIGHT IS WITHOUT ELECTRIC HEAT & WITHOUT PACKAGING.  
FOR OPTIONS & ACCESSORIES, REFER TO THE PRODUCT DATA CATALOG.

**Carrier** THIS DOCUMENT IS THE PROPERTY OF CARRIER CORPORATION AND IS DELIVERED UPON THE EXPRESS CONDITION THAT THE CONTENTS WILL NOT BE DISCLOSED OR USED WITHOUT CARRIER CORPORATION'S WRITTEN CONSENT. SUBMISSION OF THESE DRAWINGS OR DOCUMENTS DOES NOT CONSTITUTE PART PERFORMANCE OR ACCEPTANCE OF CONTRACT.

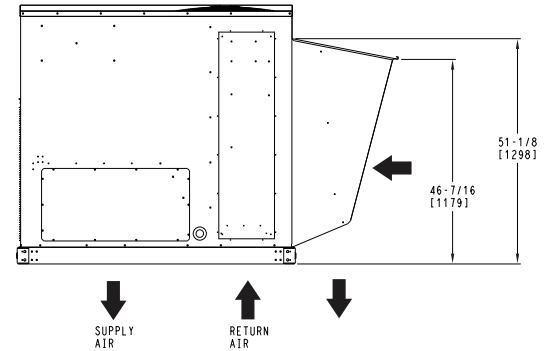
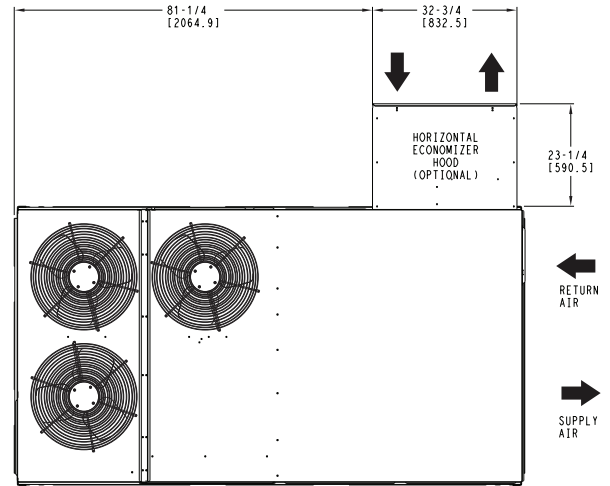
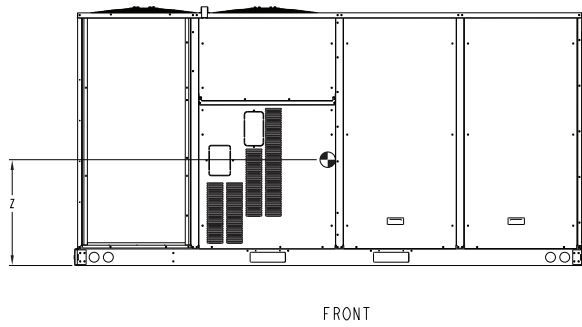
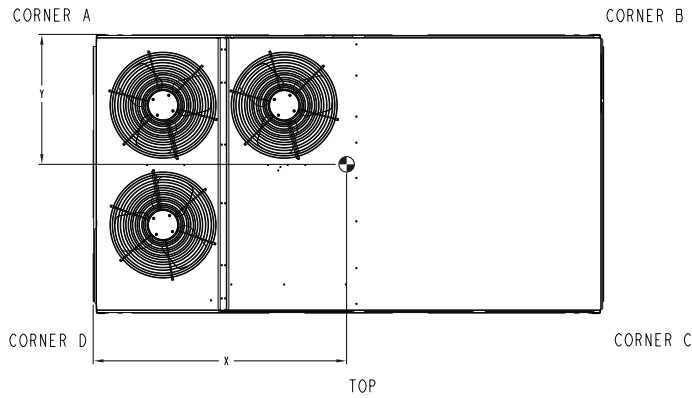

**HORIZONTAL ECONOMIZER**

ITC CLASSIFICATION U.S. ECCN:NSR	SHEET 2 OF 2	DATE 06/10/21	SUPERCEDES -	50FC 16 SINGLE ZONE ELECTRICAL COOLING WITH ELECTRIC HEAT	50TM002026	REV -
-------------------------------------	-----------------	------------------	-----------------	--	------------	----------



## 50FC\*\*16 BASE UNIT DIMENSIONS – CLEARANCES

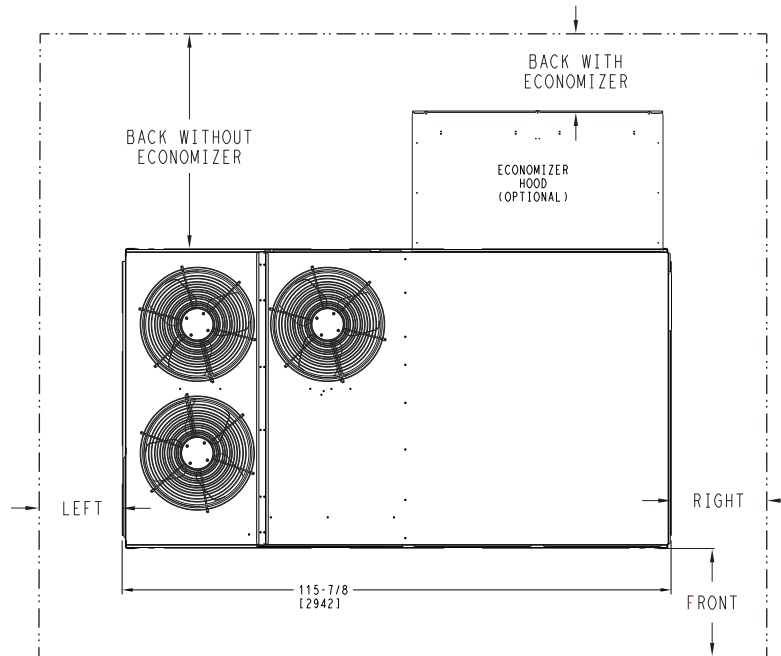

### CLEARANCE<sup>a, b</sup>

SURFACE	Service with Conductive Barrier	Service with Non-conductive Barrier	Operating Clearance
FRONT	48 in. (1219 mm)	36 in. (914 mm)	18 in. (457 mm)
LEFT	48 in. (1219 mm)	42 in. (1067 mm)	18 in. (457 mm)
BACK W/O ECONOMIZER	48 in. (1219 mm)	42 in. (1067 mm)	18 in. (457 mm)
BACK W/ ECONOMIZER	36 in. (914 mm)	36 in. (914 mm)	18 in. (457 mm)
RIGHT	36 in. (914 mm)	36 in. (914 mm)	18 in. (457 mm)
TOP	72 in. (1829 mm)	72 in. (1829 mm)	72 in. (1829 mm)

NOTE(S):

- a. For all minimum clearances local codes or jurisdictions may prevail.
- b. See page 29 for 50FC 08-12 clearances. See page 32 for 50FC 14 clearances.

## ROOF CURB DIMENSIONS — 48/50FC 08-14

ROOF CURB ACCESSORY #	A
CRRFCURB003A01	14" [356]
CRRFCURB004A01	24" [610]

- NOTES:**
1. ROOFCURB ACCESSORY IS SHIPPED DISASSEMBLED.
  2. INSULATED PANELS: 25.4 (1") THK. POLYURETHANE FOAM, 44.5 (1-3/4) # DENSITY.
  3. DIMENSIONS IN [ ] ARE IN MILLIMETERS.
  4. ROOFCURB: 18 GAGE STEEL.
  5. ATTACH DUCTWORK TO CURB. (FLANGES OF DUCT REST ON CURB).
  6. SERVICE CLEARANCE 4 FEET ON EACH SIDE.
  7. DIRECTION OF AIR FLOW.
  8. CONNECTOR PACKAGE CRBTMPWR002A01 IS FOR THRU-THE-CURB GAS TYPE PACKAGE CRBTMPWR004A01 IS FOR THRU-THE-BOTTOM TYPE GAS CONNECTIONS.

CONNECTOR PKG. ACC.	GAS CONNECTION TYPE	GAS FITTING	POWER WIRING FITTING	CONTROL WIRING FITTING	ACCESSORY CONVENIENCE OUTLET WIRING CONNECTOR
CRBTMPWR002A01	THRU THE CURB	3/4" [19] NPT	1 1/4" [31.7] NPT	1/2" [12.7] NPT	1/2" [12.7] NPT
CRBTMPWR004A01	THRU THE BOTTOM				

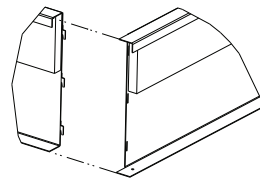
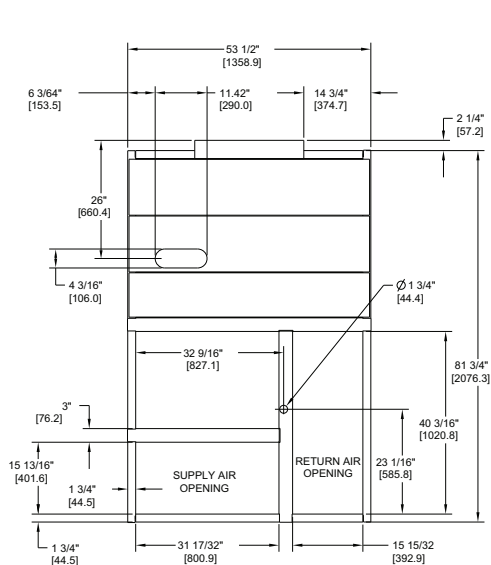

VIEW "B"  
CORNER DETAIL

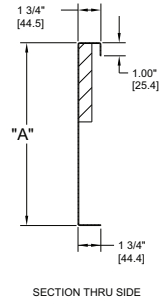

SECTION THRU SIDE

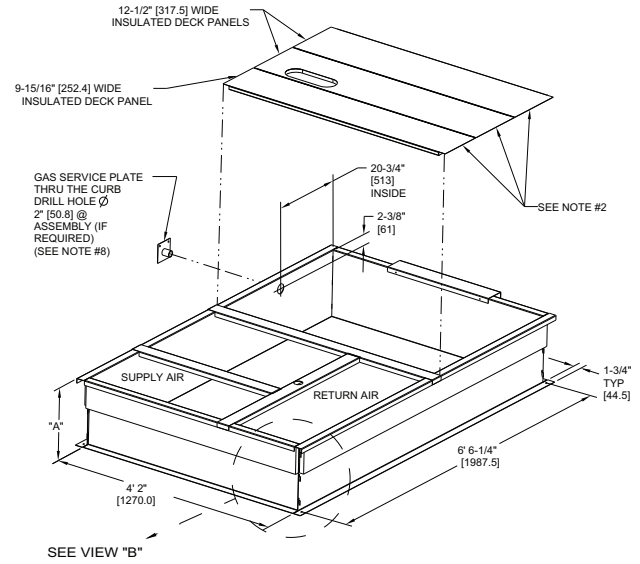

SEE VIEW "B"

CERTIFIED DRAWING

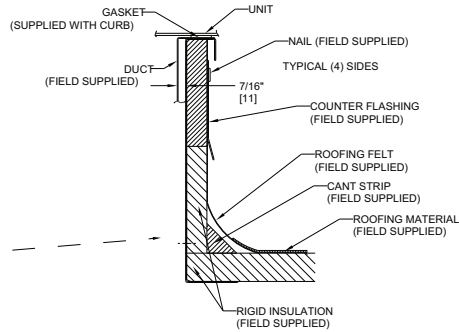
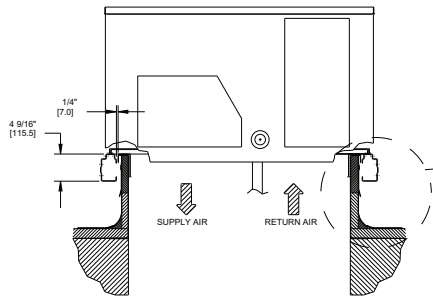

C	6' 6 1/4" WAS 6' 7 1/8", 4' 2" WAS 4' 2 13/16", 18 GA WAS 16 GA.; 15 13/16" WAS 15 15/16"; NAIL FIELD SUPPLIED WAS WITH CURB	4/22/13	MMC	-	-	1067898						
REV	REVISION RECORD	DATE	BY	CHK'D	APP'D	ECN NO.						

DRAWING RELEASE LEVEL: PRODUCTION		UNLESS OTHERWISE SPECIFIED DIMENSIONS ARE IN INCHES TOLERANCES ON:		THIS DOCUMENT AND THE INFORMATION CONTAINED THEREIN IS PROPRIETARY TO CARRIER CORPORATION AND SHALL NOT BE USED OR DISCLOSED TO OTHERS, IN WHOLE OR IN PART, WITHOUT THE WRITTEN AUTHORIZATION OF CARRIER CORPORATION.	
THIRD ANGLE PROJECTION		1 DEC ±.0005	2 DEC ±.0010	3 DEC ±.0015	ANG ±.005
MATERIAL	-	AUTHORIZATION NUMBER		TITLE	
ENGINEERING REQUIREMENTS	T-005, Y-002	1029120		CURB ASY, ROOF	
WEIGHT	-	ENGINEERING	MANUFACTURING	SIZE	DRAWING NUMBER
SURFACE FINISH	MFG/PURCH	DRAFTER	CHECKER	D	50HJ405012
		MODEL (INTERNAL USE ONLY)		SCALE	DISTRIBUTION
				N/A	



### ROOF CURB DIMENSIONS — 48/50FC 16

ROOF CURB ACCESSORY #	A
CRRCURB074A00	14" [356]
CRRCURB075A00	24" [610]

- NOTES:
1. ROOF CURB ACCESSORY IS SHIPPED DISASSEMBLED.
  2. INSULATED PANELS: 1/2" THK. NEOPRENE FOAM, 1.0# DENSITY.
  3. DIMENSIONS IN [ ] ARE IN MILLIMETERS.
  4. ROOF CURB SIDEWALLS: 16 GAGE STEEL.
  5. ATTACH DUCTWORK TO CURB: (FLANGES OF DUCT REST ON CURB).
  6. SERVICE CLEARANCE 4 FT ON EACH SIDE.
  7. DIRECTION OF AIR FLOW.
  8. "L" & "S" DESIGNATIONS DENOTE LOCATION OF COMMON CROSS RAIL. (POSITION "L" FOR LARGE DUCT OPENING CURB).

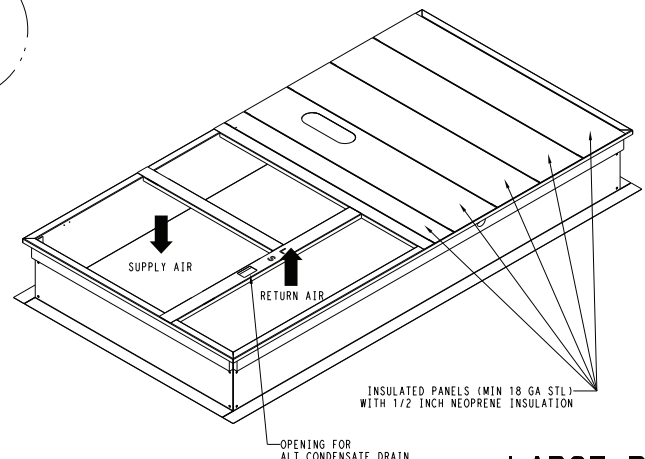
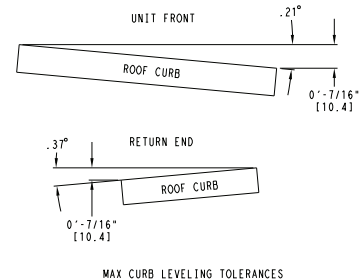
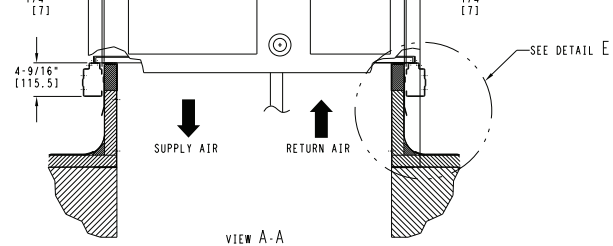
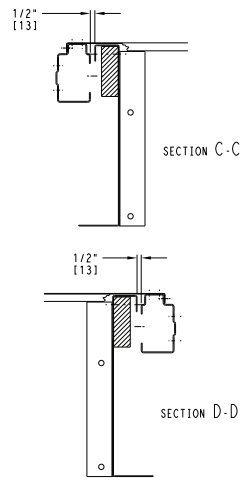
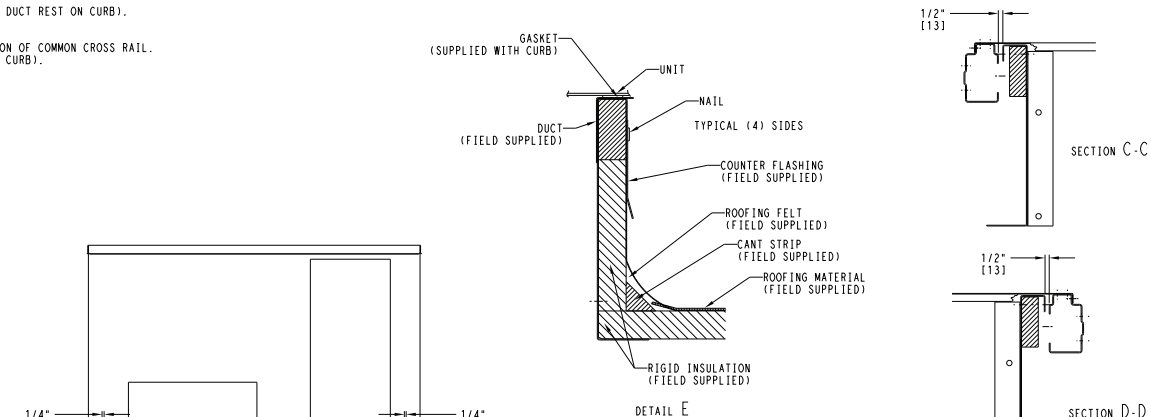
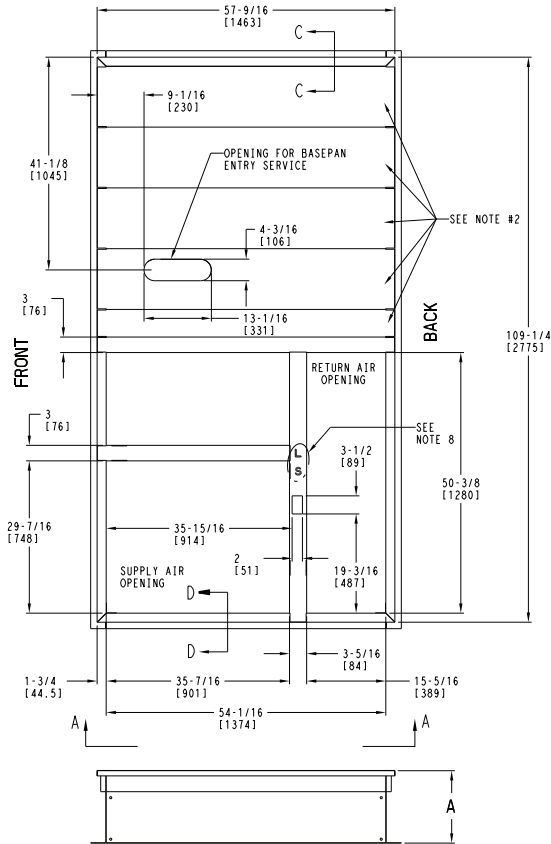

### LARGE DUCT OPENINGS

50TM500780	REV B
------------	-------



## 48/50FC\*\*08 TWO STAGE COOLING CAPACITIES

48/50FC**08				AMBIENT TEMPERATURE (F)															
				85			95			105			115			125			
				EAT (db)			EAT (db)			EAT (db)			EAT (db)			EAT (db)			
				75	80	85	75	80	85	75	80	85	75	80	85	75	80	85	
2250 cfm	EAT (wb)	58	TC	77.2	77.2	84.6	73.2	73.2	80.4	68.3	68.3	77.8	63.9	63.9	72.9	59.0	59.0	67.6	
			SHC	65.1	74.8	84.6	61.6	71.0	80.4	58.8	68.3	77.8	54.8	63.9	72.9	50.4	59.0	67.6	
		62	TC	81.8	81.8	81.8	77.0	77.0	78.0	71.8	71.8	75.0	66.3	66.3	71.7	60.4	60.4	68.1	
			SHC	59.0	69.9	80.8	56.2	67.1	78.0	53.2	64.1	75.0	50.0	60.9	71.7	46.6	57.3	68.1	
		67	TC	90.7	90.7	90.7	85.6	85.6	85.6	80.1	80.1	80.1	74.1	74.1	74.1	67.7	67.7	67.7	
			SHC	48.5	59.2	70.0	45.6	56.5	67.3	42.7	53.6	64.5	39.6	50.5	61.5	36.4	47.3	58.3	
	72	TC	100.6	100.6	100.6	95.0	95.0	95.0	89.1	89.1	89.1	82.7	82.7	82.7	75.8	75.8	75.8		
		SHC	38.0	48.4	58.7	35.1	45.6	56.1	32.1	42.8	53.4	29.0	39.7	50.5	25.7	36.5	47.4		
	76	TC	—	109.2	109.2	—	103.5	103.5	—	97.0	97.0	—	90.1	90.1	—	82.7	82.7		
		SHC	—	39.2	51.6	—	36.4	48.7	—	33.8	46.2	—	30.9	40.4	—	27.8	38.0		
	2650 cfm	EAT (wb)	58	TC	81.2	81.2	92.1	77.1	77.1	87.6	72.8	72.8	82.8	68.0	68.0	77.6	62.8	62.8	71.9
				SHC	70.4	81.2	92.1	66.7	77.1	87.6	62.7	72.8	82.8	58.5	68.0	77.6	53.8	62.8	71.9
62			TC	84.8	84.8	89.1	79.8	79.8	86.1	74.5	74.5	82.9	68.8	68.8	79.0	64.0	64.0	71.7	
			SHC	64.1	76.6	89.1	61.2	73.7	86.1	58.0	70.5	82.9	54.5	66.8	79.0	49.3	60.5	71.7	
67			TC	93.9	93.9	93.9	88.5	88.5	88.5	82.7	82.7	82.7	76.5	76.5	76.5	69.8	69.8	69.8	
			SHC	52.0	64.5	77.1	49.1	61.7	74.3	46.1	58.8	71.4	43.0	55.6	68.3	39.7	52.3	65.0	
72		TC	103.8	103.8	103.8	98.0	98.0	98.0	91.8	91.8	91.8	85.1	85.1	85.1	77.9	77.9	77.9		
		SHC	39.6	51.9	64.1	36.7	49.1	61.4	33.7	46.1	58.6	30.5	43.0	55.6	27.2	39.8	52.3		
76		TC	—	112.5	112.5	—	106.3	106.3	—	99.6	99.6	—	92.4	92.4	—	84.7	84.7		
		SHC	—	41.5	56.0	—	38.7	49.3	—	35.9	47.3	—	32.8	44.8	—	29.6	41.9		
3000 cfm		EAT (wb)	58	TC	84.9	84.9	96.2	80.6	80.6	91.4	76.0	76.0	86.4	71.1	71.1	81.0	65.6	65.6	74.9
				SHC	73.7	84.9	96.2	69.7	80.6	91.4	65.6	76.0	86.4	61.1	71.1	81.0	56.2	65.6	74.9
	62		TC	87.0	87.0	95.8	81.7	81.7	92.1	76.6	76.6	88.1	72.9	72.9	78.4	66.9	66.9	74.1	
			SHC	68.1	82.0	95.8	64.8	78.4	92.1	61.3	74.7	88.1	55.1	66.8	78.4	51.3	62.7	74.1	
	67		TC	96.1	96.1	96.1	90.5	90.5	90.5	84.5	84.5	84.5	78.1	78.1	78.1	71.2	71.2	71.2	
			SHC	54.8	68.9	83.0	51.9	66.0	80.1	48.9	63.0	77.1	45.7	59.8	73.9	42.3	56.5	70.6	
	72	TC	106.0	106.0	106.0	100.0	100.0	100.0	93.6	93.6	93.6	86.7	86.7	86.7	79.3	79.3	79.3		
		SHC	40.9	54.7	68.6	38.0	51.9	65.8	34.9	48.9	62.9	31.7	45.7	59.7	28.4	42.4	56.5		
	76	TC	—	114.6	114.6	—	108.2	108.2	—	101.3	101.3	—	94.0	94.0	—	86.0	86.0		
		SHC	—	43.2	55.5	—	40.4	53.3	—	37.4	50.8	—	34.3	48.0	—	31.0	44.8		
	3400 cfm	EAT (wb)	58	TC	88.5	88.5	100.2	84.0	84.0	95.2	79.1	79.1	89.9	73.9	73.9	84.2	68.3	68.3	77.9
				SHC	76.8	88.5	100.2	72.7	84.0	95.2	68.4	79.1	89.9	63.7	73.9	84.2	58.6	68.3	77.9
62			TC	89.3	89.3	101.7	84.6	84.6	97.2	80.8	80.8	88.0	75.0	75.0	84.2	68.3	68.3	81.2	
			SHC	71.8	86.8	101.7	68.2	82.7	97.2	62.2	75.1	88.0	58.7	71.5	84.2	55.4	68.3	81.2	
67			TC	98.0	98.0	98.0	92.3	92.3	92.3	86.2	86.2	86.2	79.6	79.6	80.1	72.5	72.5	76.6	
			SHC	57.9	73.6	89.3	55.0	70.7	86.4	51.9	67.6	83.4	48.7	64.4	80.1	45.2	60.9	76.6	
72		TC	108.0	108.0	108.0	101.8	101.8	101.8	95.3	95.3	95.3	88.2	88.2	88.2	80.6	80.6	80.6		
		SHC	42.3	57.8	73.3	39.3	54.9	70.5	36.2	51.9	67.5	33.0	48.7	64.3	29.6	45.3	61.0		
76		TC	—	116.6	116.6	—	110.0	110.0	—	102.9	102.9	—	95.4	95.4	—	87.3	87.3		
		SHC	—	44.9	59.6	—	42.1	57.0	—	39.1	54.3	—	35.9	51.3	—	32.6	48.0		
3750 cfm		EAT (wb)	58	TC	91.2	91.2	103.2	86.5	86.5	98.1	81.5	81.5	92.5	76.1	76.1	86.6	70.2	70.2	80.1
				SHC	79.2	91.2	103.2	75.0	86.5	98.1	70.5	81.5	92.5	65.6	76.1	86.6	60.3	70.2	80.1
	62		TC	93.3	93.3	99.3	86.6	86.6	102.0	82.0	82.0	94.4	76.2	76.2	90.2	70.3	70.3	83.5	
			SHC	71.5	85.4	99.3	71.2	86.6	102.0	65.9	80.1	94.4	62.1	76.2	90.2	57.1	70.3	83.5	
	67		TC	99.5	99.5	99.5	93.6	93.6	93.6	87.4	87.4	88.6	80.6	80.6	85.2	73.4	73.4	81.5	
			SHC	60.5	77.6	94.7	57.5	74.6	91.7	54.4	71.5	88.6	51.1	68.2	85.2	47.5	64.5	81.5	
	72	TC	109.4	109.4	109.4	103.2	103.2	103.2	96.5	96.5	96.5	89.2	89.2	89.2	81.5	81.5	81.5		
		SHC	43.4	60.4	77.3	40.4	57.4	74.4	37.3	54.3	71.4	34.0	51.1	68.2	30.7	47.7	64.8		
	76	TC	—	118.0	118.0	—	111.3	111.3	—	104.1	104.1	—	96.4	96.4	—	88.2	88.2		
		SHC	—	46.4	62.7	—	43.5	60.0	—	40.4	57.1	—	37.2	54.0	—	33.8	50.7		

**LEGEND**

- Do Not Operate
- cfm — Cubic Feet Per Minute (Supply Air)
- EAT (db) — Entering Air Temperature (dry bulb)
- EAT (wb) — Entering Air Temperature (wet bulb)
- SHC — Sensible Heat Capacity (1000 Btuh) Gross
- TC — Total Capacity (1000 Btuh) Gross

NOTE: See minimum-maximum airflow ratings on page 8.



## 48/50FC\*\*08 SINGLE STAGE COOLING CAPACITIES

48/50FC**08			AMBIENT TEMPERATURE (F)																
			85			95			105			115			125				
			EAT (db)			EAT (db)			EAT (db)			EAT (db)			EAT (db)				
			75	80	85	75	80	85	75	80	85	75	80	85	75	80	85		
900 cfm	EAT (wb)	58	TC	39.1	39.1	44.6	36.6	36.6	42.0	34.1	34.1	39.2	31.4	31.4	36.3	28.5	28.5	33.1	
			SHC	33.6	39.1	44.6	31.3	36.6	42.0	29.0	34.1	39.2	26.5	31.4	36.3	23.9	28.5	33.1	
		62	TC	42.2	42.2	42.2	39.2	39.2	40.0	36.1	36.1	38.0	32.7	32.7	35.9	29.2	29.2	33.7	
			SHC	30.1	36.0	41.9	28.2	34.1	40.0	26.2	32.1	38.0	24.1	30.0	35.9	21.9	27.8	33.7	
		67	TC	47.4	47.4	47.4	44.3	44.3	44.3	40.9	40.9	40.9	37.4	37.4	37.4	33.6	33.6	33.6	
			SHC	24.8	30.7	36.5	22.9	28.8	34.6	21.0	26.8	32.7	18.9	24.8	30.7	16.8	22.7	28.6	
	72	TC	53.1	53.1	53.1	49.8	49.8	49.8	46.2	46.2	46.2	42.5	42.5	42.5	38.5	38.5	38.5		
		SHC	19.6	25.2	30.9	17.7	23.4	29.1	15.7	21.4	27.2	13.6	19.4	25.2	11.5	17.3	23.1		
	76	TC	—	58.1	58.1	—	54.6	54.6	—	50.8	50.8	—	46.8	46.8	—	42.5	42.5		
		SHC	—	20.6	26.9	—	18.8	25.1	—	17.0	23.3	—	15.0	20.3	—	12.9	18.4		
	1050 cfm	EAT (wb)	58	TC	42.0	42.0	47.8	39.4	39.4	45.0	36.7	36.7	42.1	33.9	33.9	39.0	30.8	30.8	35.6
				SHC	36.2	42.0	47.8	33.8	39.4	45.0	31.3	36.7	42.1	28.7	33.9	39.0	25.9	30.8	35.6
62			TC	44.0	44.0	46.7	40.9	40.9	44.7	37.6	37.6	42.5	34.2	34.2	40.1	30.8	30.8	37.3	
			SHC	33.1	39.9	46.7	31.1	37.9	44.7	29.0	35.8	42.5	26.7	33.4	40.1	24.3	30.8	37.3	
67			TC	49.3	49.3	49.3	46.0	46.0	46.0	42.5	42.5	42.5	38.8	38.8	38.8	34.9	34.9	34.9	
			SHC	26.9	33.6	40.4	24.9	31.7	38.5	22.9	29.7	36.5	20.8	27.7	34.5	18.6	25.5	32.3	
72		TC	55.1	55.1	55.1	51.6	51.6	51.6	47.9	47.9	47.9	44.0	44.0	44.0	39.7	39.7	39.7		
		SHC	20.6	27.3	33.9	18.6	25.3	32.0	16.6	23.3	30.1	14.5	21.3	28.1	12.3	19.1	25.9		
76		TC	—	60.0	60.0	—	56.3	56.3	—	52.4	52.4	—	48.2	48.2	—	—	—		
		SHC	—	22.0	29.4	—	20.1	26.1	—	18.1	24.4	—	16.0	22.5	—	—	—		
1200 cfm		EAT (wb)	58	TC	45.0	45.0	51.2	42.3	42.3	48.2	39.4	39.4	45.1	36.4	36.4	41.8	33.1	33.1	38.2
				SHC	38.9	45.0	51.2	36.4	42.3	48.2	33.7	39.4	45.1	30.9	36.4	41.8	27.9	33.1	38.2
	62		TC	45.7	45.7	52.0	42.6	42.6	49.5	39.8	39.8	46.3	36.4	36.4	43.7	33.1	33.1	40.0	
			SHC	36.3	44.2	52.0	34.1	41.8	49.5	31.5	38.9	46.3	29.2	36.4	43.7	26.3	33.1	40.0	
	67		TC	51.1	51.1	51.1	47.6	47.6	47.6	44.0	44.0	44.0	40.2	40.2	40.2	36.1	36.1	36.8	
			SHC	29.2	37.2	45.1	27.2	35.2	43.2	25.1	33.1	41.1	23.0	31.0	39.0	20.8	28.8	36.8	
	72	TC	56.9	56.9	56.9	53.2	53.2	53.2	49.4	49.4	49.4	45.3	45.3	45.3	40.9	40.9	40.9		
		SHC	21.7	29.6	37.5	19.7	27.6	35.5	17.6	25.6	33.5	15.5	23.5	31.4	13.3	21.2	29.2		
	76	TC	—	61.8	61.8	—	57.9	57.9	—	53.8	53.8	—	—	—	—	—	—		
		SHC	—	23.3	30.7	—	21.4	28.9	—	19.3	27.0	—	—	—	—	—	—		
	1350 cfm	EAT (wb)	58	TC	47.1	47.1	53.4	44.2	44.2	50.4	41.2	41.2	47.1	38.0	38.0	43.7	34.6	34.6	39.9
				SHC	40.7	47.1	53.4	38.0	44.2	50.4	35.3	41.2	47.1	32.4	38.0	43.7	29.3	34.6	39.9
62			TC	47.5	47.5	54.9	44.6	44.6	51.7	41.3	41.3	49.2	38.1	38.1	45.6	34.7	34.7	41.7	
			SHC	38.2	46.6	54.9	35.7	43.7	51.7	33.4	41.3	49.2	30.6	38.1	45.6	27.6	34.7	41.7	
67			TC	52.2	52.2	52.2	48.6	48.6	48.6	44.9	44.9	44.9	41.0	41.0	42.5	36.8	36.8	40.2	
			SHC	30.9	39.8	48.7	28.9	37.8	46.7	26.8	35.8	44.7	24.7	33.6	42.5	22.4	31.3	40.2	
72		TC	58.0	58.0	58.0	54.3	54.3	54.3	50.3	50.3	50.3	46.1	46.1	46.1	41.6	41.6	41.6		
		SHC	22.5	31.3	40.1	20.5	29.3	38.1	18.4	27.2	36.1	16.2	25.1	33.9	14.0	22.8	31.7		
76		TC	—	62.8	62.8	—	58.8	58.8	—	—	—	—	—	—	—	—	—		
		SHC	—	24.3	32.7	—	22.3	30.8	—	—	—	—	—	—	—	—	—		
2520 cfm		EAT (wb)	58	TC	49.2	49.2	55.9	46.2	46.2	52.6	43.1	43.1	49.2	39.8	39.8	45.6	36.2	36.2	41.7
				SHC	42.6	49.2	55.9	39.9	46.2	52.6	37.0	43.1	49.2	34.0	39.8	45.6	30.7	36.2	41.7
	62		TC	48.7	48.7	58.0	46.3	46.3	54.8	43.2	43.2	51.3	39.8	39.8	47.6	36.3	36.3	43.6	
			SHC	39.3	48.7	58.0	37.8	46.3	54.8	35.0	43.2	51.3	32.1	39.8	47.6	28.9	36.3	43.6	
	67		TC	53.3	53.3	53.3	49.6	49.6	51.0	45.8	45.8	48.8	41.8	41.8	46.6	37.5	37.5	44.1	
			SHC	33.0	43.0	53.0	30.9	41.0	51.0	28.8	38.8	48.8	26.6	36.6	46.6	24.3	34.2	44.1	
	72	TC	59.1	59.1	59.1	55.3	55.3	55.3	51.2	51.2	51.2	46.9	46.9	46.9	42.3	42.3	42.3		
		SHC	23.4	33.3	43.3	21.3	31.3	41.2	19.2	29.2	39.2	17.1	27.0	37.0	14.8	24.7	34.7		
	76	TC	—	—	—	—	—	—	—	—	—	—	—	—	—	—	—		
		SHC	—	—	—	—	—	—	—	—	—	—	—	—	—	—	—		

**LEGEND**

- Do Not Operate
- cfm — Cubic Feet Per Minute (Supply Air)
- EAT (db) — Entering Air Temperature (dry bulb)
- EAT (wb) — Entering Air Temperature (wet bulb)
- SHC — Sensible Heat Capacity (1000 Btuh) Gross
- TC — Total Capacity (1000 Btuh) Gross

NOTE: See minimum-maximum airflow ratings on page 8.



# Performance data (cont)



## 48/50FC\*N08 — UNIT WITH HUMIDI-MIZER® SYSTEM IN SUBCOOLING MODE — COOLING CAPACITIES

TEMP (F) AIR ENTERING CONDENSER (Edb)		AIR ENTERING EVAPORATOR — SCFM/BF (80 F db)								
		2250/0.14			3000 /0.15			3750/0.17		
		Air Entering Evaporator — Ewb (F)								
		72	67	62	72	67	62	72	67	62
75	TC	95.0	86.0	77.0	104.0	93.0	83.0	108.0	97.0	87.0
	SHC	38.0	49.0	60.0	47.0	60.0	72.0	53.0	69.0	83.0
	kW	6.4	6.4	6.3	6.6	6.5	6.4	6.6	6.5	6.4
85	TC	86.0	81.0	71.0	97.0	86.0	77.0	101.0	91.0	81.0
	SHC	29.0	44.0	54.0	40.0	53.0	67.0	46.0	63.0	76.0
	kW	6.9	7.0	7.0	7.2	7.1	7.0	7.2	7.2	7.1
95	TC	84.0	74.0	65.0	90.0	80.0	71.0	94.0	83.0	74.0
	SHC	28.0	38.0	49.0	34.0	47.0	61.0	40.0	56.0	70.0
	kW	7.8	7.7	7.7	7.9	7.8	7.7	8.0	7.9	7.8
105	TC	77.0	68.0	59.0	82.0	73.0	64.0	86.0	76.0	68.0
	SHC	22.0	32.0	43.0	27.0	41.0	55.0	33.0	49.0	64.0
	kW	8.7	8.5	8.4	8.8	8.6	8.5	8.8	8.7	8.6
115	TC	70.0	61.0	53.0	74.0	65.0	57.0	78.0	68.0	60.0
	SHC	15.0	26.0	37.0	20.0	35.0	49.0	25.0	42.0	57.0
	kW	9.5	9.4	9.3	9.6	9.5	9.4	9.7	9.5	9.4
125	TC	62.0	54.0	46.0	66.0	58.0	50.0	69.0	60.0	53.0
	SHC	8.0	20.0	31.0	13.0	28.0	42.0	18.0	35.0	50.0
	kW	10.5	10.4	10.3	10.6	10.5	10.3	10.7	10.5	10.4

## 48/50FC\*N08 — UNIT WITH HUMIDI-MIZER SYSTEM IN HOT GAS REHEAT MODE — COOLING CAPACITIES

TEMP (F) AIR ENTERING CONDENSER (Edb)		AIR ENTERING EVAPORATOR — Ewb (F)								
		75 Dry Bulb 62.5 Wet Bulb (50% Relative)			75 Dry Bulb 64 Wet Bulb (56% Relative)			75 Dry Bulb 65.3 Wet Bulb (60% Relative)		
		Air Entering Evaporator — cfm								
		2250	3000	3750	2250	3000	3750	2250	3000	3750
80	TC	35.0	39.0	41.0	37.0	40.0	42.0	38.0	41.0	43.0
	SHC	8.0	14.0	21.0	4.0	9.0	15.0	0.0	5.0	10.0
	kW	6.6	6.6	6.6	6.6	6.6	6.6	6.6	6.6	6.6
75	TC	37.0	41.0	43.0	39.0	42.0	44.0	40.0	43.0	46.0
	SHC	9.0	16.0	23.0	6.0	12.0	17.0	2.0	7.0	12.0
	kW	5.9	5.9	6.0	5.9	6.0	6.0	6.0	6.1	6.1
70	TC	40.0	43.0	45.0	41.0	44.0	47.0	42.0	46.0	48.0
	SHC	11.0	18.0	25.0	8.0	13.0	19.0	4.0	9.0	14.0
	kW	5.7	5.7	5.7	5.7	5.7	5.7	5.7	5.7	5.7
60	TC	44.0	47.0	50.0	45.0	49.0	51.0	47.0	50.0	53.0
	SHC	15.0	22.0	29.0	11.0	17.0	23.0	8.0	13.0	18.0
	kW	5.7	5.7	5.7	5.7	5.7	5.7	5.7	5.7	5.7
50	TC	47.0	51.0	54.0	49.0	53.0	55.0	51.0	54.0	57.0
	SHC	19.0	26.0	33.0	15.0	21.0	27.0	12.0	17.0	22.0
	kW	5.7	5.6	5.6	5.6	5.6	5.6	5.6	5.6	5.6
40	TC	51.0	55.0	58.0	53.0	57.0	60.0	54.0	59.0	61.0
	SHC	22.0	30.0	37.0	18.0	25.0	31.0	15.0	21.0	26.0
	kW	5.6	5.6	5.6	5.6	5.6	5.6	5.6	5.6	5.6

### LEGEND

- Edb** — Entering Dry Bulb
- Ewb** — Entering Wet Bulb
- kW** — Compressor Power Input
- SCFM/BF** — Standard Cubic Feet per Minute/Bypass Factor
- SHC** — Sensible Heat Capacity (1000 Btuh) Gross
- TC** — Total Capacity (1000 Btuh) Gross

## 48/50FC\*\*09 TWO STAGE COOLING CAPACITIES

48/50FC**09				AMBIENT TEMPERATURE (F)															
				85			95			105			115			125			
				EAT (db)			EAT (db)			EAT (db)			EAT (db)			EAT (db)			
				75	80	85	75	80	85	75	80	85	75	80	85	75	80	85	
2550 cfm	EAT (wb)	58	TC	89.0	89.0	100.5	85.0	85.0	96.1	80.8	80.8	91.4	76.3	76.3	86.4	71.6	71.6	81.1	
			SHC	77.5	89.0	100.5	74.0	85.0	96.1	70.3	80.8	91.4	66.3	76.3	86.4	62.1	71.6	81.1	
		62	TC	93.2	93.2	96.4	88.1	88.1	93.9	82.8	82.8	91.1	77.3	77.3	88.0	72.5	72.5	82.7	
			SHC	70.4	83.4	96.4	67.8	80.9	93.9	65.1	78.1	91.1	62.2	75.1	88.0	58.3	70.5	82.7	
		67	TC	102.4	102.4	102.4	97.0	97.0	97.0	91.3	91.3	91.3	85.3	85.3	85.3	79.0	79.0	79.0	
			SHC	57.4	70.4	83.3	54.9	67.9	81.0	52.3	65.4	78.4	49.7	62.8	75.9	47.0	60.1	73.2	
	72	TC	112.6	112.6	112.6	106.8	106.8	106.8	100.7	100.7	100.7	94.3	94.3	94.3	87.5	87.5	87.5		
		SHC	44.3	57.0	69.7	41.8	54.6	67.4	39.3	52.1	65.0	36.6	49.5	62.5	33.9	46.9	59.8		
	76	TC	—	121.3	121.3	—	115.2	115.2	—	108.7	108.7	—	101.9	101.9	—	94.7	94.7		
		SHC	—	45.9	59.9	—	43.6	54.2	—	41.3	52.9	—	38.8	50.9	—	36.1	48.6		
	3000 cfm	EAT (wb)	58	TC	94.1	94.1	106.3	89.9	89.9	101.5	85.3	85.3	96.5	80.6	80.6	91.1	75.5	75.5	85.4
				SHC	82.0	94.1	106.3	78.2	89.9	101.5	74.2	85.3	96.5	70.0	80.6	91.1	65.5	75.5	85.4
62			TC	96.1	96.1	106.2	91.0	91.0	103.2	86.7	86.7	97.7	82.4	82.4	89.1	75.6	75.6	88.9	
			SHC	76.1	91.2	106.2	73.4	88.3	103.2	69.4	83.5	97.7	63.9	76.5	89.1	62.3	75.6	88.9	
67			TC	105.5	105.5	105.5	99.9	99.9	99.9	93.9	93.9	93.9	87.6	87.6	87.6	81.0	81.0	81.2	
			SHC	61.2	76.4	91.5	58.7	73.9	89.1	56.1	71.4	86.6	53.5	68.7	84.0	50.7	65.9	81.2	
72		TC	115.8	115.8	115.8	109.8	109.8	109.8	103.4	103.4	103.4	96.7	96.7	96.7	89.5	89.5	89.5		
		SHC	45.8	60.7	75.6	43.3	58.3	73.2	40.7	55.7	70.8	38.0	53.1	68.2	35.2	50.4	65.6		
76		TC	—	124.6	124.6	—	118.3	118.3	—	111.5	111.5	—	104.4	104.4	—	—	—		
		SHC	—	47.8	61.4	—	45.5	59.5	—	43.0	57.3	—	40.5	55.1	—	—	—		
3400 cfm		EAT (wb)	58	TC	97.9	97.9	110.6	93.5	93.5	105.6	88.8	88.8	100.3	83.7	83.7	94.6	78.4	78.4	88.7
				SHC	85.3	97.9	110.6	81.4	93.5	105.6	77.2	88.8	100.3	72.7	83.7	94.6	68.0	78.4	88.7
	62		TC	98.6	98.6	113.3	94.4	94.4	107.7	89.2	89.2	103.1	83.8	83.8	98.4	78.5	78.5	92.2	
			SHC	80.4	96.8	113.3	76.5	92.1	107.7	72.8	88.0	103.1	69.2	83.8	98.4	64.7	78.5	92.2	
	67		TC	107.7	107.7	107.7	101.8	101.8	101.8	95.6	95.6	95.6	89.1	89.1	90.8	82.3	82.3	87.9	
			SHC	64.4	81.4	98.5	61.9	79.0	96.0	59.3	76.4	93.5	56.6	73.7	90.8	53.8	70.9	87.9	
	72	TC	118.0	118.0	118.0	111.8	111.8	111.8	105.1	105.1	105.1	98.2	98.2	98.2	90.9	90.9	90.9		
		SHC	46.9	63.7	80.5	44.4	61.2	78.1	41.8	58.7	75.6	39.1	56.1	73.1	36.3	53.4	70.4		
	76	TC	—	126.9	126.9	—	120.3	120.3	—	113.3	113.3	—	—	—	—	—	—		
		SHC	—	49.3	65.1	—	46.9	63.0	—	44.4	60.7	—	—	—	—	—	—		
	3850 cfm	EAT (wb)	58	TC	101.6	101.6	114.7	97.0	97.0	109.5	91.9	91.9	103.9	86.7	86.7	98.0	81.1	81.1	91.7
				SHC	88.6	101.6	114.7	84.5	97.0	109.5	80.0	91.9	103.9	75.3	86.7	98.0	70.4	81.1	91.7
62			TC	104.0	104.0	110.7	97.1	97.1	113.8	92.1	92.1	108.0	86.8	86.8	101.9	81.2	81.2	95.4	
			SHC	80.2	95.5	110.7	80.4	97.1	113.8	76.1	92.1	108.0	71.7	86.8	101.9	66.9	81.2	95.4	
67			TC	109.6	109.6	109.6	103.5	103.5	103.7	97.2	97.2	101.0	90.5	90.5	98.2	83.6	83.6	95.1	
			SHC	67.9	87.0	106.1	65.4	84.6	103.7	62.8	81.9	101.0	60.0	79.1	98.2	57.1	76.1	95.1	
72		TC	120.0	120.0	120.0	113.5	113.5	113.5	106.7	106.7	106.7	99.7	99.7	99.7	92.2	92.2	92.2		
		SHC	48.0	66.9	85.8	45.5	64.4	83.4	42.8	61.9	80.9	40.2	59.3	78.3	37.4	56.5	75.6		
76		TC	—	128.9	128.9	—	122.2	122.2	—	—	—	—	—	—	—	—	—		
		SHC	—	50.6	68.7	—	48.2	66.5	—	—	—	—	—	—	—	—	—		
4250 cfm		EAT (wb)	58	TC	104.4	104.4	117.8	99.6	99.6	112.4	94.4	94.4	106.6	88.9	88.9	100.5	83.1	83.1	94.0
				SHC	91.0	104.4	117.8	86.7	99.6	112.4	82.1	94.4	106.6	77.3	88.9	100.5	72.2	83.1	94.0
	62		TC	104.6	104.6	122.5	99.7	99.7	116.9	94.5	94.5	110.8	89.0	89.0	104.5	83.2	83.2	97.8	
			SHC	86.7	104.6	122.5	82.6	99.7	116.9	78.2	94.5	110.8	73.5	89.0	104.5	68.6	83.2	97.8	
	67		TC	110.9	110.9	112.7	104.7	104.7	110.1	98.2	98.2	107.3	91.5	91.5	104.3	84.5	84.5	101.0	
			SHC	70.9	91.8	112.7	68.3	89.2	110.1	65.6	86.5	107.3	62.8	83.6	104.3	59.9	80.5	101.0	
	72	TC	121.4	121.4	121.4	114.8	114.8	114.8	107.9	107.9	107.9	100.7	100.7	100.7	93.0	93.0	93.0		
		SHC	48.8	69.6	90.3	46.3	67.1	87.9	43.7	64.6	85.4	41.0	61.9	82.8	38.3	59.2	80.1		
	76	TC	—	130.4	130.4	—	—	—	—	—	—	—	—	—	—	—	—		
		SHC	—	51.6	71.7	—	—	—	—	—	—	—	—	—	—	—	—		

### LEGEND

- Do Not Operate
- cfm — Cubic Feet Per Minute (Supply Air)
- EAT (db) — Entering Air Temperature (dry bulb)
- EAT (wb) — Entering Air Temperature (wet bulb)
- SHC — Sensible Heat Capacity (1000 Btuh) Gross
- TC — Total Capacity (1000 Btuh) Gross

NOTE: See minimum-maximum airflow ratings on page 8.

## 48/50FC\*\*09 SINGLE STAGE COOLING CAPACITIES

48/50FC**09				AMBIENT TEMPERATURE (F)															
				85			95			105			115			125			
				EAT (db)			EAT (db)			EAT (db)			EAT (db)			EAT (db)			
				75	80	85	75	80	85	75	80	85	75	80	85	75	80	85	
1275 cfm	EAT (wb)	58	TC	44.0	44.0	50.1	41.4	41.4	47.2	38.6	38.6	44.2	35.7	35.7	41.0	32.6	32.6	37.6	
			SHC	38.0	44.0	50.1	35.6	41.4	47.2	33.1	38.6	44.2	30.4	35.7	41.0	27.6	32.6	37.6	
		62	TC	46.7	46.7	47.8	43.4	43.4	45.9	40.0	40.0	43.9	36.4	36.4	41.7	32.8	32.8	39.2	
			SHC	34.4	41.1	47.8	32.4	39.2	45.9	30.4	37.1	43.9	28.2	35.0	41.7	25.9	32.6	39.2	
		67	TC	52.2	52.2	52.2	48.8	48.8	48.8	45.1	45.1	45.1	41.3	41.3	41.3	37.3	37.3	37.3	
			SHC	28.2	34.9	41.6	26.2	33.0	39.7	24.2	31.0	37.7	22.2	28.9	35.7	20.0	26.8	33.6	
	72	TC	58.1	58.1	58.1	54.5	54.5	54.5	50.7	50.7	50.7	46.6	46.6	46.6	42.3	42.3	42.3		
		SHC	22.0	28.6	35.2	20.0	26.7	33.3	18.0	24.7	31.3	15.9	22.6	29.3	13.8	20.5	27.3		
	76	TC	—	63.2	63.2	—	59.5	59.5	—	55.4	55.4	—	—	—	—	—	—		
		SHC	—	23.3	30.3	—	21.5	27.2	—	19.5	25.7	—	—	—	—	—	—		
	1500 cfm	EAT (wb)	58	TC	47.2	47.2	53.6	44.4	44.4	50.6	41.5	41.5	47.3	38.3	38.3	43.9	35.0	35.0	40.3
				SHC	40.8	47.2	53.6	38.2	44.4	50.6	35.6	41.5	47.3	32.7	38.3	43.9	29.8	35.0	40.3
62			TC	48.6	48.6	53.5	45.2	45.2	51.4	41.7	41.7	49.0	38.4	38.4	45.9	35.1	35.1	42.2	
			SHC	37.7	45.6	53.5	35.7	43.5	51.4	33.5	41.2	49.0	30.9	38.4	45.9	28.0	35.1	42.2	
67			TC	54.2	54.2	54.2	50.6	50.6	50.6	46.7	46.7	46.7	42.7	42.7	42.7	38.5	38.5	38.5	
			SHC	30.4	38.3	46.2	28.5	36.4	44.2	26.4	34.3	42.2	24.3	32.2	40.2	22.1	30.1	38.0	
72		TC	60.2	60.2	60.2	56.4	56.4	56.4	52.4	52.4	52.4	48.1	48.1	48.1	43.6	43.6	43.6		
		SHC	23.0	30.8	38.5	21.0	28.8	36.6	19.0	26.8	34.6	16.9	24.7	32.6	14.7	22.6	30.5		
76		TC	—	65.4	65.4	—	—	—	—	—	—	—	—	—	—	—	—		
		SHC	—	24.6	31.8	—	—	—	—	—	—	—	—	—	—	—	—		
1700 cfm		EAT (wb)	58	TC	49.6	49.6	56.3	46.7	46.7	53.1	43.5	43.5	49.7	40.3	40.3	46.1	36.8	36.8	42.3
				SHC	42.9	49.6	56.3	40.2	46.7	53.1	37.4	43.5	49.7	34.4	40.3	46.1	31.3	36.8	42.3
	62		TC	50.0	50.0	57.8	46.9	46.9	54.9	43.6	43.6	51.8	40.3	40.3	48.1	36.9	36.9	44.2	
			SHC	40.4	49.1	57.8	37.9	46.4	54.9	35.4	43.6	51.8	32.6	40.3	48.1	29.5	36.9	44.2	
	67		TC	55.5	55.5	55.5	51.8	51.8	51.8	47.8	47.8	47.8	43.7	43.7	44.0	39.4	39.4	41.8	
			SHC	32.3	41.2	50.1	30.3	39.2	48.1	28.3	37.2	46.1	26.1	35.0	44.0	23.9	32.9	41.8	
	72	TC	61.6	61.6	61.6	57.7	57.7	57.7	53.6	53.6	53.6	49.2	49.2	49.2	44.5	44.5	44.5		
		SHC	23.8	32.6	41.4	21.9	30.7	39.5	19.8	28.6	37.5	17.7	26.5	35.4	15.5	24.4	33.2		
	76	TC	—	—	—	—	—	—	—	—	—	—	—	—	—	—	—		
		SHC	—	—	—	—	—	—	—	—	—	—	—	—	—	—	—		
	1925 cfm	EAT (wb)	58	TC	51.9	51.9	58.8	48.8	48.8	55.5	45.5	45.5	51.9	42.1	42.1	48.1	38.5	38.5	44.2
				SHC	44.9	51.9	58.8	42.1	48.8	55.5	39.2	45.5	51.9	36.1	42.1	48.1	32.8	38.5	44.2
62			TC	51.9	51.9	61.2	48.9	48.9	57.8	45.6	45.6	54.1	42.2	42.2	50.2	38.6	38.6	46.2	
			SHC	42.7	51.9	61.2	39.9	48.9	57.8	37.1	45.6	54.1	34.1	42.2	50.2	31.0	38.6	46.2	
67			TC	56.7	56.7	56.7	52.9	52.9	52.9	48.8	48.8	50.3	44.6	44.6	48.1	40.2	40.2	45.8	
			SHC	34.4	44.4	54.4	32.3	42.4	52.4	30.2	40.3	50.3	28.1	38.1	48.1	25.8	35.8	45.8	
72		TC	62.9	62.9	62.9	58.9	58.9	58.9	54.6	54.6	54.6	50.1	50.1	50.1	—	—	—		
		SHC	24.7	34.6	44.5	22.7	32.6	42.6	20.6	30.6	40.5	18.4	28.4	38.4	—	—	—		
76		TC	—	—	—	—	—	—	—	—	—	—	—	—	—	—	—		
		SHC	—	—	—	—	—	—	—	—	—	—	—	—	—	—	—		
2125 cfm		EAT (wb)	58	TC	53.6	53.6	60.8	50.4	50.4	57.3	47.1	47.1	53.6	43.5	43.5	49.7	39.8	39.8	45.6
				SHC	46.5	53.6	60.8	43.6	50.4	57.3	40.5	47.1	53.6	37.3	43.5	49.7	34.0	39.8	45.6
	62		TC	53.7	53.7	63.2	50.5	50.5	59.7	47.1	47.1	55.9	43.6	43.6	51.9	39.9	39.9	47.6	
			SHC	44.1	53.7	63.2	41.3	50.5	59.7	38.4	47.1	55.9	35.3	43.6	51.9	32.1	39.9	47.6	
	67		TC	57.6	57.6	58.0	53.7	53.7	56.1	49.6	49.6	53.9	45.2	45.2	51.7	40.7	40.7	49.3	
			SHC	36.1	47.1	58.0	34.1	45.1	56.1	31.9	42.9	53.9	29.7	40.7	51.7	27.4	38.3	49.3	
	72	TC	63.8	63.8	63.8	59.7	59.7	59.7	55.3	55.3	55.3	—	—	—	—	—	—		
		SHC	25.4	36.3	47.2	23.4	34.3	45.2	21.3	32.2	43.2	—	—	—	—	—	—		
	76	TC	—	—	—	—	—	—	—	—	—	—	—	—	—	—	—		
		SHC	—	—	—	—	—	—	—	—	—	—	—	—	—	—	—		

**LEGEND**

- Do Not Operate
- cfm — Cubic Feet Per Minute (Supply Air)
- EAT (db) — Entering Air Temperature (dry bulb)
- EAT (wb) — Entering Air Temperature (wet bulb)
- SHC — Sensible Heat Capacity (1000 Btuh) Gross
- TC — Total Capacity (1000 Btuh) Gross

NOTE: See minimum-maximum airflow ratings on page 8.



## 48/50FC\*N09 — UNIT WITH HUMIDI-MIZER® SYSTEM IN SUBCOOLING MODE — COOLING CAPACITIES

TEMP (F) AIR ENTERING CONDENSER (Edb)		AIR ENTERING EVAPORATOR — SCFM/BF (80 F db)								
		2550/0.11			3400/0.14			4250/0.15		
		Air Entering Evaporator — Ewb (F)								
		72	67	62	72	67	62	72	67	62
75	TC	108.0	96.0	86.0	108.0	97.0	90.0	119.0	107.0	97.0
	SHC	46.0	57.0	69.0	48.0	64.0	82.0	61.0	79.0	95.0
	kW	7.3	7.2	7.1	7.2	7.1	7.1	7.5	7.3	7.3
85	TC	101.0	86.0	79.0	107.0	96.0	85.0	111.0	100.0	90.0
	SHC	40.0	48.0	63.0	47.0	63.0	77.0	54.0	73.0	88.0
	kW	8.0	7.8	7.8	8.1	8.0	7.9	8.1	8.0	7.9
95	TC	93.0	82.0	73.0	99.0	88.0	78.0	103.0	92.0	84.0
	SHC	33.0	46.0	58.0	40.0	56.0	71.0	47.0	66.0	77.0
	kW	8.7	8.6	8.5	8.8	8.7	8.6	8.9	8.7	8.6
105	TC	85.0	75.0	66.0	90.0	80.0	71.0	94.0	83.0	75.0
	SHC	27.0	40.0	52.0	33.0	50.0	65.0	40.0	60.0	74.0
	kW	9.5	9.4	9.3	9.6	9.5	9.4	9.7	9.5	9.4
115	TC	77.0	68.0	59.0	81.0	72.0	63.0	85.0	75.0	69.0
	SHC	21.0	33.0	46.0	26.0	43.0	59.0	33.0	53.0	62.0
	kW	10.4	10.3	10.2	10.5	10.4	10.3	10.5	10.4	10.3
125	TC	69.0	60.0	51.0	73.0	64.0	56.0	75.0	66.0	60.0
	SHC	14.0	27.0	40.0	20.0	37.0	52.0	25.0	46.0	58.0
	kW	11.4	11.3	11.2	11.5	11.4	11.3	11.5	11.4	11.3

## 48/50FC\*N09 — UNIT WITH HUMIDI-MIZER SYSTEM IN HOT GAS REHEAT MODE — COOLING CAPACITIES

TEMP (F) AIR ENTERING CONDENSER (Edb)		AIR ENTERING EVAPORATOR — Ewb (F)								
		75 Dry Bulb 62.5 Wet Bulb (50% Relative)			75 Dry Bulb 64 Wet Bulb (56% Relative)			75 Dry Bulb 65.3 Wet Bulb (60% Relative)		
		Air Entering Evaporator — cfm								
		2550	3400	4250	2550	3400	4250	2550	3400	4250
80	TC	36.0	39.0	41.0	37.0	40.0	430.0	38.0	42.0	44.0
	SHC	7.0	14.0	22.0	2.0	8.0	155.0	-2.0	3.0	9.0
	kW	6.2	6.2	6.2	6.3	6.3	6.2	6.3	6.3	6.3
75	TC	38.0	41.0	43.0	39.0	43.0	45.0	41.0	44.0	46.0
	SHC	8.0	16.0	24.0	4.0	11.0	17.0	0.0	6.0	12.0
	kW	5.4	5.4	5.4	5.4	5.5	5.5	5.6	5.6	5.7
70	TC	40.0	43.0	46.0	41.0	45.0	47.0	43.0	46.0	48.0
	SHC	10.0	18.0	26.0	6.0	13.0	19.0	2.0	8.0	14.0
	kW	5.2	5.2	5.2	5.2	5.2	5.2	5.2	5.2	5.2
60	TC	44.0	48.0	50.0	46.0	49.0	52.0	47.0	50.0	53.0
	SHC	14.0	22.0	30.0	9.0	16.0	23.0	5.0	11.0	17.0
	kW	5.2	5.1	5.1	5.1	5.1	5.1	5.1	5.1	5.1
50	TC	48.0	52.0	54.0	50.0	54.0	56.0	51.0	55.0	57.0
	SHC	17.0	26.0	34.0	13.0	20.0	27.0	9.0	15.0	21.0
	kW	5.1	5.1	5.1	5.1	5.1	5.1	5.1	5.1	5.1
40	TC	52.0	56.0	58.0	54.0	58.0	60.0	55.0	59.0	62.0
	SHC	21.0	30.0	38.0	16.0	24.0	31.0	12.0	19.0	25.0
	kW	5.1	5.1	5.1	5.1	5.1	5.1	5.1	5.1	5.0

### LEGEND

- Edb** — Entering Dry Bulb
- Ewb** — Entering Wet Bulb
- kW** — Compressor Power Input
- SCFM/BF** — Standard Cubic Feet per Minute/Bypass Factor
- SHC** — Sensible Heat Capacity (1000 Btuh) Gross
- TC** — Total Capacity (1000 Btuh) Gross

## 48/50FC\*\*12 TWO STAGE COOLING CAPACITIES

48/50FC**12			AMBIENT TEMPERATURE (F)																
			85			95			105			115			125				
			EAT (db)			EAT (db)			EAT (db)			EAT (db)			EAT (db)				
			75	80	85	75	80	85	75	80	85	75	80	85	75	80	85		
3000 cfm	EAT (wb)	58	TC	109.6	109.6	124.0	104.5	104.5	118.3	99.2	99.2	112.4	93.2	93.2	105.7	87.0	87.0	98.9	
			SHC	95.3	109.6	124.0	90.7	104.5	118.3	86.0	99.2	112.4	80.7	93.2	105.7	75.2	87.0	98.9	
		62	TC	115.5	115.5	117.5	108.9	108.9	114.0	102.1	102.1	110.5	94.8	94.8	106.6	87.4	87.4	101.9	
			SHC	85.7	101.6	117.5	82.3	98.2	114.0	78.8	94.6	110.5	75.0	90.8	106.6	70.8	86.4	101.9	
		67	TC	126.7	126.7	126.7	120.0	120.0	120.0	112.6	112.6	112.6	104.8	104.8	104.8	96.6	96.6	96.6	
			SHC	69.4	85.2	101.0	66.2	82.0	97.8	62.7	78.6	94.4	59.1	75.0	90.9	55.4	71.3	87.2	
	72	TC	139.0	139.0	139.0	131.5	131.5	131.5	123.9	123.9	123.9	115.5	115.5	115.5	106.8	106.8	106.8		
		SHC	53.2	68.7	84.2	49.8	65.4	81.0	46.4	62.1	77.7	42.8	58.5	74.2	39.1	54.9	70.7		
	76	TC	—	149.4	149.4	—	141.9	141.9	—	133.5	133.5	—	124.7	124.7	—	115.4	115.4		
		SHC	—	55.1	71.6	—	52.0	66.0	—	48.7	63.4	—	45.2	60.3	—	41.6	57.0		
	3500 cfm	EAT (wb)	58	TC	115.9	115.9	130.9	110.5	110.5	125.0	104.6	104.6	118.4	98.3	98.3	111.5	91.7	91.7	104.1
				SHC	100.8	115.9	130.9	96.0	110.5	125.0	90.7	104.6	118.4	85.2	98.3	111.5	79.4	91.7	104.1
62			TC	119.0	119.0	129.3	112.4	112.4	125.7	105.3	105.3	121.3	98.8	98.8	114.9	91.9	91.9	108.4	
			SHC	92.8	111.0	129.3	89.3	107.5	125.7	85.3	103.3	121.3	80.4	97.6	114.9	75.3	91.9	108.4	
67			TC	130.5	130.5	130.5	123.1	123.1	123.1	115.7	115.7	115.7	107.5	107.5	107.5	98.9	98.9	98.9	
			SHC	74.2	92.6	110.9	70.8	89.2	107.6	67.4	85.8	104.2	63.8	82.2	100.6	60.0	78.5	96.9	
72		TC	142.9	142.9	142.9	135.1	135.1	135.1	127.1	127.1	127.1	118.4	118.4	118.4	109.2	109.2	109.2		
		SHC	55.3	73.4	91.5	51.9	70.1	88.2	48.5	66.7	84.9	44.8	63.1	81.4	41.1	59.4	77.8		
76		TC	—	153.8	153.8	—	145.5	145.5	—	136.8	136.8	—	127.6	127.6	—	118.0	118.0		
		SHC	—	57.9	74.8	—	54.7	71.9	—	51.3	68.8	—	47.7	65.6	—	44.1	62.1		
4000 cfm		EAT (wb)	58	TC	121.3	121.3	137.0	115.4	115.4	130.5	109.2	109.2	123.6	102.6	102.6	116.2	95.6	95.6	108.4
				SHC	105.5	121.3	137.0	100.3	115.4	130.5	94.8	109.2	123.6	88.9	102.6	116.2	82.7	95.6	108.4
	62		TC	122.0	122.0	139.7	117.0	117.0	132.7	111.8	111.8	120.7	102.7	102.7	120.9	95.7	95.7	112.8	
			SHC	99.0	119.3	139.7	94.0	113.4	132.7	86.4	103.5	120.7	84.5	102.7	120.9	78.5	95.7	112.8	
	67		TC	133.4	133.4	133.4	125.8	125.8	125.8	118.0	118.0	118.0	109.5	109.5	110.0	100.7	100.7	106.2	
			SHC	78.8	99.6	120.5	75.4	96.2	117.1	71.9	92.8	113.7	68.2	89.1	110.0	64.4	85.3	106.2	
	72	TC	145.9	145.9	145.9	138.0	138.0	138.0	129.5	129.5	129.5	120.5	120.5	120.5	111.1	111.1	111.1		
		SHC	57.3	77.9	98.5	53.9	74.6	95.3	50.4	71.1	91.9	46.7	67.5	88.3	43.0	63.8	84.6		
	76	TC	—	156.9	156.9	—	148.4	148.4	—	139.4	139.4	—	129.9	129.9	—	—	—		
		SHC	—	60.4	80.2	—	57.1	77.2	—	53.7	73.9	—	50.1	70.5	—	—	—		
	4500 cfm	EAT (wb)	58	TC	125.5	125.5	141.8	119.5	119.5	135.1	113.0	113.0	127.9	106.1	106.1	120.2	98.8	98.8	112.0
				SHC	109.3	125.5	141.8	103.9	119.5	135.1	98.2	113.0	127.9	92.0	106.1	120.2	85.5	98.8	112.0
62			TC	127.9	127.9	139.9	120.5	120.5	136.6	113.2	113.2	133.0	106.2	106.2	125.0	98.9	98.9	116.6	
			SHC	100.4	120.2	139.9	96.9	116.8	136.6	93.3	113.2	133.0	87.4	106.2	125.0	81.2	98.9	116.6	
67			TC	135.6	135.6	135.6	127.8	127.8	127.8	119.8	119.8	122.9	111.1	111.1	119.1	102.1	102.1	115.1	
			SHC	83.2	106.5	129.8	79.8	103.1	126.4	76.2	99.5	122.9	72.5	95.8	119.1	68.6	91.8	115.1	
72		TC	148.2	148.2	148.2	140.2	140.2	140.2	131.4	131.4	131.4	122.2	122.2	122.2	112.5	112.5	112.5		
		SHC	59.2	82.3	105.4	55.8	79.0	102.1	52.2	75.4	98.7	48.5	71.8	95.1	44.8	68.0	91.3		
76		TC	—	159.3	159.3	—	150.6	150.6	—	141.4	141.4	—	—	—	—	—	—		
		SHC	—	62.8	85.2	—	59.5	82.1	—	56.0	78.8	—	—	—	—	—	—		
5000 cfm		EAT (wb)	58	TC	129.3	129.3	146.0	123.1	123.1	139.1	116.3	116.3	131.5	109.1	109.1	123.5	101.5	101.5	115.1
				SHC	112.6	129.3	146.0	107.1	123.1	139.1	101.0	116.3	131.5	94.6	109.1	123.5	87.9	101.5	115.1
	62		TC	129.8	129.8	150.6	123.0	123.0	144.4	116.4	116.4	136.8	109.2	109.2	128.5	101.6	101.6	119.7	
			SHC	106.5	128.6	150.6	101.7	123.0	144.4	96.0	116.4	136.8	89.9	109.2	128.5	83.5	101.6	119.7	
	67		TC	137.8	137.8	139.0	129.4	129.4	135.4	121.3	121.3	131.7	112.4	112.4	127.6	103.3	103.3	123.2	
			SHC	87.5	113.3	139.0	83.9	109.6	135.4	80.3	106.0	131.7	76.5	102.0	127.6	72.4	97.8	123.2	
	72	TC	150.1	150.1	150.1	141.9	141.9	141.9	132.9	132.9	132.9	123.5	123.5	123.5	113.6	113.6	113.6		
		SHC	60.9	86.5	112.0	57.6	83.2	108.8	54.0	79.6	105.3	50.3	76.0	101.7	46.5	72.2	97.9		
	76	TC	—	161.4	161.4	—	152.4	152.4	—	—	—	—	—	—	—	—	—		
		SHC	—	65.1	90.1	—	61.7	86.8	—	—	—	—	—	—	—	—	—		

### LEGEND

- Do Not Operate
- cfm — Cubic Feet Per Minute (Supply Air)
- EAT (db) — Entering Air Temperature (dry bulb)
- EAT (wb) — Entering Air Temperature (wet bulb)
- SHC — Sensible Heat Capacity (1000 Btuh) Gross
- TC — Total Capacity (1000 Btuh) Gross

NOTE: See minimum-maximum airflow ratings on page 8.

## 48/50FC\*\*12 SINGLE STAGE COOLING CAPACITIES

48/50FC**12				AMBIENT TEMPERATURE (F)															
				85			95			105			115			125			
				EAT (db)			EAT (db)			EAT (db)			EAT (db)			EAT (db)			
				75	80	85	75	80	85	75	80	85	75	80	85	75	80	85	
1800 cfm	EAT (wb)	58	TC	60.4	60.4	68.6	57.0	57.0	64.9	53.4	53.4	60.9	49.6	49.6	56.7	45.5	45.5	52.2	
			SHC	52.3	60.4	68.6	49.2	57.0	64.9	45.9	53.4	60.9	42.4	49.6	56.7	38.8	45.5	52.2	
		62	TC	62.7	62.7	67.1	58.5	58.5	64.6	54.2	54.2	62.1	50.1	50.1	57.9	45.6	45.6	54.6	
			SHC	47.8	57.5	67.1	45.3	55.0	64.6	42.8	52.5	62.1	39.5	48.7	57.9	36.6	45.6	54.6	
		67	TC	69.4	69.4	69.4	65.1	65.1	65.1	60.5	60.5	60.5	55.5	55.5	55.5	50.4	50.4	50.4	
			SHC	38.6	48.2	57.8	36.2	45.8	55.4	33.7	43.4	53.0	31.2	40.8	50.5	28.5	38.2	47.9	
	72	TC	76.8	76.8	76.8	72.2	72.2	72.2	67.4	67.4	67.4	62.1	62.1	62.1	56.6	56.6	56.6		
		SHC	29.2	38.7	48.3	26.9	36.4	46.0	24.4	34.0	43.6	21.9	31.5	41.1	19.3	28.9	38.5		
	76	TC	—	83.1	83.1	—	78.3	78.3	—	—	—	—	—	—	—	—	—		
		SHC	—	31.1	40.1	—	28.8	38.0	—	—	—	—	—	—	—	—	—		
	2100 cfm	EAT (wb)	58	TC	64.2	64.2	72.8	60.5	60.5	68.8	56.7	56.7	64.6	52.6	52.6	60.1	48.3	48.3	55.4
				SHC	55.6	64.2	72.8	52.3	60.5	68.8	48.8	56.7	64.6	45.1	52.6	60.1	41.3	48.3	55.4
62			TC	64.8	64.8	74.2	60.7	60.7	71.2	56.8	56.8	67.3	52.7	52.7	62.8	48.4	48.4	57.8	
			SHC	52.1	63.2	74.2	49.4	60.3	71.2	46.2	56.8	67.3	42.7	52.7	62.8	39.0	48.4	57.8	
67			TC	71.6	71.6	71.6	67.1	67.1	67.1	62.3	62.3	62.3	57.1	57.1	57.1	51.7	51.7	53.9	
			SHC	41.5	52.7	63.9	39.1	50.4	61.6	36.6	47.8	59.1	34.0	45.2	56.5	31.4	42.6	53.9	
72		TC	79.0	79.0	79.0	74.3	74.3	74.3	69.2	69.2	69.2	63.8	63.8	63.8	58.1	58.1	58.1		
		SHC	30.6	41.7	52.8	28.2	39.4	50.5	25.8	36.9	48.1	23.2	34.3	45.5	20.5	31.7	42.9		
76		TC	—	—	—	—	—	—	—	—	—	—	—	—	—	—	—		
		SHC	—	—	—	—	—	—	—	—	—	—	—	—	—	—	—		
2400 cfm		EAT (wb)	58	TC	67.2	67.2	76.1	63.5	63.5	72.1	59.5	59.5	67.7	55.2	55.2	63.0	50.6	50.6	57.9
				SHC	58.2	67.2	76.1	54.9	63.5	72.1	51.3	59.5	67.7	47.4	55.2	63.0	43.3	50.6	57.9
	62		TC	67.3	67.3	79.2	63.6	63.6	75.0	59.6	59.6	70.5	55.2	55.2	65.6	50.7	50.7	60.5	
			SHC	55.3	67.2	79.2	52.1	63.5	75.0	48.6	59.6	70.5	44.8	55.2	65.6	40.9	50.7	60.5	
	67		TC	73.2	73.2	73.2	68.6	68.6	68.6	63.6	63.6	65.0	58.3	58.3	62.3	52.8	52.8	59.6	
			SHC	44.4	57.1	69.9	42.0	54.7	67.5	39.4	52.2	65.0	36.8	49.6	62.3	34.1	46.8	59.6	
	72	TC	80.7	80.7	80.7	75.9	75.9	75.9	70.6	70.6	70.6	65.0	65.0	65.0	59.1	59.1	59.1		
		SHC	31.9	44.6	57.2	29.5	42.2	54.9	27.0	39.7	52.4	24.4	37.1	49.9	21.7	34.5	47.2		
	76	TC	—	—	—	—	—	—	—	—	—	—	—	—	—	—	—		
		SHC	—	—	—	—	—	—	—	—	—	—	—	—	—	—	—		
	2700 cfm	EAT (wb)	58	TC	69.9	69.9	79.2	65.9	65.9	74.8	61.8	61.8	70.3	57.3	57.3	65.3	52.6	52.6	60.1
				SHC	60.6	69.9	79.2	57.0	65.9	74.8	53.3	61.8	70.3	49.3	57.3	65.3	45.0	52.6	60.1
62			TC	69.9	69.9	82.2	66.0	66.0	77.8	61.8	61.8	73.1	57.3	57.3	68.0	52.6	52.6	62.7	
			SHC	57.5	69.9	82.2	54.1	66.0	77.8	50.5	61.8	73.1	46.6	57.3	68.0	42.5	52.6	62.7	
67			TC	74.5	74.5	75.7	69.8	69.8	73.3	64.7	64.7	70.6	59.2	59.2	67.8	53.6	53.6	64.9	
			SHC	47.1	61.4	75.7	44.7	59.0	73.3	42.1	56.4	70.6	39.4	53.6	67.8	36.6	50.8	64.9	
72		TC	82.1	82.1	82.1	77.1	77.1	77.1	71.7	71.7	71.7	65.9	65.9	65.9	—	—	—		
		SHC	33.1	47.3	61.5	30.7	44.9	59.1	28.1	42.4	56.7	25.5	39.8	54.1	—	—	—		
76		TC	—	—	—	—	—	—	—	—	—	—	—	—	—	—	—		
		SHC	—	—	—	—	—	—	—	—	—	—	—	—	—	—	—		
3000 cfm		EAT (wb)	58	TC	72.1	72.1	81.6	68.0	68.0	77.1	63.7	63.7	72.4	59.1	59.1	67.4	54.2	54.2	61.9
				SHC	62.6	72.1	81.6	58.9	68.0	77.1	55.0	63.7	72.4	50.9	59.1	67.4	46.5	54.2	61.9
	62		TC	72.1	72.1	84.8	68.1	68.1	80.3	63.8	63.8	75.4	59.1	59.1	70.1	54.3	54.3	64.6	
			SHC	59.4	72.1	84.8	55.9	68.1	80.3	52.1	63.8	75.4	48.1	59.1	70.1	43.9	54.3	64.6	
	67		TC	75.5	75.5	81.2	70.7	70.7	78.7	65.5	65.5	75.9	60.0	60.0	73.0	54.5	54.5	69.1	
			SHC	49.7	65.5	81.2	47.2	63.0	78.7	44.5	60.2	75.9	41.8	57.4	73.0	38.6	53.9	69.1	
	72	TC	83.1	83.1	83.1	78.0	78.0	78.0	—	—	—	—	—	—	—	—	—		
		SHC	34.2	50.0	65.7	31.8	47.6	63.3	—	—	—	—	—	—	—	—	—		
	76	TC	—	—	—	—	—	—	—	—	—	—	—	—	—	—	—		
		SHC	—	—	—	—	—	—	—	—	—	—	—	—	—	—	—		

### LEGEND

- Do Not Operate
- cfm — Cubic Feet Per Minute (Supply Air)
- EAT (db) — Entering Air Temperature (dry bulb)
- EAT (wb) — Entering Air Temperature (wet bulb)
- SHC — Sensible Heat Capacity (1000 Btuh) Gross
- TC — Total Capacity (1000 Btuh) Gross

NOTE: See minimum-maximum airflow ratings on page 8.

# Performance data (cont)



## 48/50FC\*N12 — UNIT WITH HUMIDI-MIZER® SYSTEM IN SUBCOOLING MODE — COOLING CAPACITIES

TEMP (F) AIR ENTERING CONDENSER (Edb)		AIR ENTERING EVAPORATOR — SCFM/BF (80 F db)								
		3000/0.06			4000/0.08			5000/0.10		
		Air Entering Evaporator — Ewb (F)								
		72	67	62	72	67	62	72	67	62
75	TC	137.0	124.0	111.0	147.0	132.0	120.0	147.0	135.0	129.0
	SHC	58.0	78.0	97.0	72.0	96.0	117.0	78.0	110.0	125.0
	kW	9.6	9.4	9.2	9.8	9.6	9.4	9.8	9.7	9.6
85	TC	128.0	116.0	103.0	135.0	123.0	112.0	140.0	127.0	118.0
	SHC	51.0	72.0	89.0	61.0	88.0	109.0	72.0	104.0	118.0
	kW	10.4	10.3	10.0	10.6	10.4	10.2	10.7	10.5	10.3
95	TC	117.0	107.0	96.0	124.0	111.0	101.0	128.0	117.0	110.0
	SHC	41.0	63.0	83.0	52.0	77.0	98.0	62.0	95.0	110.0
	kW	11.3	11.1	10.9	11.4	11.2	11.0	11.5	11.3	11.2
105	TC	110.0	98.0	87.0	117.0	104.0	95.0	120.0	104.0	99.0
	SHC	35.0	55.0	76.0	46.0	72.0	89.0	55.0	83.0	99.0
	kW	12.3	12.1	11.9	12.5	12.2	12.0	12.6	12.2	12.2
115	TC	101.0	89.0	78.0	106.0	92.0	84.0	109.0	96.0	92.0
	SHC	28.0	48.0	68.0	37.0	61.0	82.0	46.0	77.0	92.0
	kW	13.4	13.2	13.0	13.6	13.3	13.1	13.6	13.4	13.3
125	TC	92.0	79.0	69.0	95.0	81.0	75.0	98.0	87.0	81.0
	SHC	20.0	39.0	60.0	28.0	52.0	74.0	37.0	69.0	81.0
	kW	14.7	14.4	14.2	14.8	14.4	14.3	14.8	14.6	14.5

## 48/50FC\*N12 — UNIT WITH HUMIDI-MIZER SYSTEM IN HOT GAS REHEAT MODE — COOLING CAPACITIES

TEMP (F) AIR ENTERING CONDENSER (Edb)		AIR ENTERING EVAPORATOR — Ewb (F)								
		75 Dry Bulb 62.5 Wet Bulb (50% Relative)			75 Dry Bulb 64 Wet Bulb (56% Relative)			75 Dry Bulb 65.3 Wet Bulb (60% Relative)		
		Air Entering Evaporator — cfm								
		3000	4000	5000	3000	4000	5000	3000	4000	5000
80	TC	45.0	49.0	52.0	46.0	51.0	53.0	48.0	52.0	54.0
	SHC	7.0	16.0	25.0	2.0	9.0	17.0	-3.0	4.0	10.0
	kW	7.4	7.6	7.7	7.6	7.7	7.7	7.7	7.8	7.8
75	TC	47.0	52.0	54.0	49.0	53.0	56.0	50.0	54.0	57.0
	SHC	9.0	18.0	28.0	4.0	12.0	20.0	0.0	7.0	14.0
	kW	6.8	6.9	6.9	6.9	6.9	7.0	7.0	7.1	7.1
70	TC	50.0	54.0	57.0	51.0	56.0	59.0	53.0	57.0	60.0
	SHC	11.0	20.0	30.0	5.0	14.0	22.0	2.0	8.0	15.0
	kW	6.7	6.7	6.7	6.7	6.7	6.7	6.7	6.8	6.8
60	TC	54.0	59.0	62.0	56.0	61.0	64.0	58.0	62.0	65.0
	SHC	15.0	25.0	35.0	9.0	18.0	26.0	5.0	12.0	19.0
	kW	6.6	6.6	6.7	6.6	6.7	6.7	6.7	6.7	6.7
50	TC	59.0	64.0	67.0	61.0	66.0	69.0	63.0	68.0	71.0
	SHC	19.0	29.0	39.0	13.0	22.0	31.0	9.0	16.0	24.0
	kW	6.6	6.6	6.6	6.6	6.6	6.6	6.6	6.6	6.6
40	TC	63.0	69.0	72.0	66.0	71.0	74.0	67.0	73.0	76.0
	SHC	23.0	33.0	44.0	17.0	26.0	35.0	13.0	20.0	28.0
	kW	6.6	6.6	6.6	6.6	6.6	6.6	6.6	6.6	6.6

### LEGEND

- Edb** — Entering Dry Bulb
- Ewb** — Entering Wet Bulb
- kW** — Compressor Power Input
- SCFM/BF** — Standard Cubic Feet per Minute/Bypass Factor
- SHC** — Sensible Heat Capacity (1000 Btuh) Gross
- TC** — Total Capacity (1000 Btuh) Gross



## 48/50FC\*\*14 TWO STAGE COOLING CAPACITIES

48/50FC**14				AMBIENT TEMPERATURE (F)												
				85			95			105			115			
				EAT (db)			EAT (db)			EAT (db)			EAT (db)			
				75	80	85	75	80	85	75	80	85	75	80	85	
3750 cfm	EAT (wb)	58	TC	126.4	126.4	144.1	118.4	118.4	135.4	109.9	109.9	126.2	101.1	101.1	116.6	
			SHC	108.8	126.4	144.1	101.4	118.4	135.4	93.6	109.9	126.2	85.5	101.1	116.6	
		62	TC	134.1	134.1	136.3	124.3	124.3	130.2	114.1	114.1	123.8	103.6	103.6	117.3	
			SHC	97.3	116.8	136.3	91.1	110.7	130.2	84.8	104.3	123.8	78.4	97.9	117.3	
		67	TC	149.5	149.5	149.5	139.3	139.3	139.3	128.6	128.6	128.6	117.4	117.4	117.4	
			SHC	78.5	97.9	117.3	72.4	91.9	111.3	66.1	85.6	105.1	59.8	79.3	98.8	
	72	TC	166.4	166.4	166.4	155.6	155.6	155.6	144.2	144.2	144.2	132.5	132.5	132.5		
		SHC	59.7	78.7	97.8	53.6	72.8	91.9	47.3	66.5	85.7	40.9	60.2	79.5		
	76	TC	—	181.4	181.4	—	169.7	169.7	—	157.7	157.7	—	145.4	145.4		
		SHC	—	63.0	83.4	—	57.1	77.5	—	51.0	68.5	—	44.7	63.1		
	4400 cfm	EAT (wb)	58	TC	135.2	135.2	153.9	126.7	126.7	144.7	117.8	117.8	135.0	108.4	108.4	124.8
				SHC	116.6	135.2	153.9	108.8	126.7	144.7	100.6	117.8	135.0	92.1	108.4	124.8
62			TC	139.3	139.3	152.1	129.4	129.4	145.7	119.0	119.0	138.8	110.0	110.0	127.5	
			SHC	106.8	129.5	152.1	100.6	123.2	145.7	94.1	116.4	138.8	85.3	106.4	127.5	
67			TC	154.8	154.8	154.8	144.1	144.1	144.1	133.1	133.1	133.1	121.5	121.5	121.5	
			SHC	84.4	107.1	129.8	78.3	101.0	123.7	72.0	94.7	117.4	65.5	88.3	111.0	
72		TC	171.9	171.9	171.9	160.5	160.5	160.5	148.7	148.7	148.7	136.5	136.5	136.5		
		SHC	61.9	84.2	106.5	55.6	78.0	100.4	49.2	71.7	94.1	42.8	65.2	87.7		
76		TC	—	186.5	186.5	—	174.5	174.5	—	162.3	162.3	—	149.4	149.4		
		SHC	—	65.6	86.0	—	59.5	80.6	—	53.3	74.7	—	46.8	68.6		
5000 cfm		EAT (wb)	58	TC	142.1	142.1	161.5	133.2	133.2	151.9	123.8	123.8	141.8	114.2	114.2	131.2
				SHC	122.7	142.1	161.5	114.5	133.2	151.9	106.0	123.8	141.8	97.2	114.2	131.2
	62		TC	143.6	143.6	165.3	136.2	136.2	151.7	125.8	125.8	143.6	114.2	114.2	137.0	
			SHC	114.9	140.2	165.3	105.3	128.5	151.7	98.2	120.9	143.6	91.6	114.2	137.0	
	67		TC	158.6	158.6	158.6	147.6	147.6	147.6	136.1	136.1	136.1	124.3	124.3	124.3	
			SHC	89.6	115.2	140.8	83.4	109.0	134.5	77.1	102.7	128.3	70.7	96.2	121.9	
	72	TC	175.7	175.7	175.7	163.9	163.9	163.9	151.9	151.9	151.9	139.4	139.4	139.4		
		SHC	63.4	88.6	113.9	57.1	82.4	107.7	50.7	76.0	101.4	44.2	69.5	94.9		
	76	TC	—	190.4	190.4	—	178.0	178.0	—	165.2	165.2	—	152.1	152.1		
		SHC	—	67.3	91.3	—	61.1	85.4	—	54.6	79.3	—	48.1	72.9		
	5650 cfm	EAT (wb)	58	TC	148.3	148.3	168.4	139.1	139.1	158.4	129.4	129.4	147.9	119.3	119.3	136.8
				SHC	128.2	148.3	168.4	119.8	139.1	158.4	111.0	129.4	147.9	101.8	119.3	136.8
62			TC	153.3	153.3	164.2	143.1	143.1	156.2	129.6	129.6	154.2	119.5	119.5	143.0	
			SHC	116.4	140.3	164.2	109.3	132.8	156.2	104.9	129.6	154.2	96.0	119.5	143.0	
67			TC	161.9	161.9	161.9	150.6	150.6	150.6	138.9	138.9	139.8	126.7	126.7	133.3	
			SHC	94.9	123.7	152.3	88.8	117.4	146.1	82.5	111.1	139.8	76.0	104.6	133.3	
72		TC	178.9	178.9	178.9	166.9	166.9	166.9	154.6	154.6	154.6	141.9	141.9	141.9		
		SHC	64.6	93.0	121.4	58.3	86.6	115.0	51.8	80.3	108.7	45.2	73.8	102.2		
76		TC	—	193.6	193.6	—	180.9	180.9	—	167.9	167.9	—	—	—		
		SHC	—	68.5	95.9	—	62.2	89.7	—	55.6	83.4	—	—	—		
6250 cfm		EAT (wb)	58	TC	153.3	153.3	173.9	143.7	143.7	163.5	133.7	133.7	152.7	123.4	123.4	141.4
				SHC	132.7	153.3	173.9	123.8	143.7	163.5	114.8	133.7	152.7	105.3	123.4	141.4
	62		TC	154.5	154.5	177.7	143.9	143.9	170.4	133.9	133.9	159.3	123.6	123.6	147.6	
			SHC	124.2	151.0	177.7	117.4	143.9	170.4	108.6	133.9	159.3	99.5	123.6	147.6	
	67		TC	164.3	164.3	164.3	153.0	153.0	156.4	140.9	140.9	150.0	128.7	128.7	143.6	
			SHC	99.8	131.2	162.7	93.6	125.0	156.4	87.3	118.6	150.0	81.0	112.3	143.6	
	72	TC	181.5	181.5	181.5	169.3	169.3	169.3	156.7	156.7	156.7	143.7	143.7	143.7		
		SHC	65.4	96.6	127.7	59.0	90.3	121.5	52.6	83.9	115.0	46.0	77.3	108.6		
	76	TC	—	196.0	196.0	—	183.1	183.1	—	169.9	169.9	—	—	—		
		SHC	—	69.0	99.3	—	62.5	93.0	—	55.8	86.4	—	—	—		

**LEGEND**

- Do Not Operate
- cfm — Cubic Feet Per Minute (Supply Air)
- EAT (db) — Entering Air Temperature (dry bulb)
- EAT (wb) — Entering Air Temperature (wet bulb)
- SHC — Sensible Heat Capacity (1000 Btuh) Gross
- TC — Total Capacity (1000 Btuh) Gross

NOTE: See minimum-maximum airflow ratings on page 8.



## 48/50FC\*\*14 SINGLE STAGE COOLING CAPACITIES

48/50FC**14				AMBIENT TEMPERATURE (F)												
				85			95			105			115			
				EAT (db)			EAT (db)			EAT (db)			EAT (db)			
				75	80	85	75	80	85	75	80	85	75	80	85	
2050 cfm	EAT (wb)	58	TC	73.0	73.0	83.0	69.0	69.0	78.6	64.9	64.9	74.1	60.6	60.6	69.3	
			SHC	63.1	73.0	83.0	59.5	69.0	78.6	55.7	64.9	74.1	51.8	60.6	69.3	
		62	TC	77.1	77.1	78.9	72.3	72.3	76.0	67.1	67.1	73.0	61.9	61.9	69.9	
			SHC	56.8	67.9	78.9	54.0	64.9	76.0	51.0	62.0	73.0	47.9	58.9	69.9	
		67	TC	85.8	85.8	85.8	80.6	80.6	80.6	75.1	75.1	75.1	69.4	69.4	69.4	
			SHC	46.5	57.6	68.6	43.7	54.6	65.7	40.7	51.7	62.8	37.6	48.7	59.7	
	72	TC	95.3	95.3	95.3	89.7	89.7	89.7	84.0	84.0	84.0	77.8	77.8	77.8		
		SHC	36.0	47.1	58.3	33.2	44.3	55.3	30.2	41.3	52.4	27.1	38.3	49.4		
	76	TC	—	103.5	103.5	—	97.5	97.5	—	91.4	91.4	—	—	—		
		SHC	—	38.5	49.7	—	35.6	46.8	—	32.8	43.9	—	—	—		
	2500 cfm	EAT (wb)	58	TC	79.3	79.3	89.9	74.9	74.9	85.2	70.5	70.5	80.3	65.7	65.7	75.0
				SHC	68.6	79.3	89.9	64.7	74.9	85.2	60.6	70.5	80.3	56.3	65.7	75.0
62			TC	80.9	80.9	90.4	75.7	75.7	87.2	71.1	71.1	82.4	65.8	65.8	78.3	
			SHC	63.8	77.1	90.4	60.7	74.0	87.2	56.8	69.6	82.4	53.3	65.8	78.3	
67			TC	89.6	89.6	89.6	84.1	84.1	84.1	78.2	78.2	78.2	72.2	72.2	72.2	
			SHC	51.0	64.4	77.8	48.0	61.5	74.8	45.0	58.4	71.9	41.9	55.3	68.7	
72		TC	99.3	99.3	99.3	93.4	93.4	93.4	87.1	87.1	87.1	80.7	80.7	80.7		
		SHC	37.9	51.5	64.9	35.0	48.5	62.0	32.0	45.4	58.9	28.9	42.4	55.8		
76		TC	—	107.4	107.4	—	—	—	—	—	—	—	—	—		
		SHC	—	40.9	54.5	—	—	—	—	—	—	—	—	—		
2900 cfm		EAT (wb)	58	TC	83.8	83.8	94.9	79.2	79.2	89.9	74.3	74.3	84.6	69.4	69.4	79.2
				SHC	72.6	83.8	94.9	68.4	79.2	89.9	64.2	74.3	84.6	59.6	69.4	79.2
	62		TC	83.9	83.9	98.8	78.7	78.7	93.3	74.4	74.4	88.2	69.5	69.5	82.6	
			SHC	68.9	83.9	98.8	64.2	78.7	93.3	60.8	74.4	88.2	56.4	69.5	82.6	
	67		TC	92.0	92.0	92.0	86.2	86.2	86.2	80.2	80.2	80.2	74.1	74.1	76.4	
			SHC	54.7	70.2	85.7	51.7	67.2	82.7	48.6	64.2	79.6	45.5	61.0	76.4	
	72	TC	101.8	101.8	101.8	95.6	95.6	95.6	89.2	89.2	89.2	82.6	82.6	82.6		
		SHC	39.4	54.9	70.6	36.4	52.0	67.5	33.4	48.9	64.4	30.2	45.7	61.3		
	76	TC	—	—	—	—	—	—	—	—	—	—	—	—		
		SHC	—	—	—	—	—	—	—	—	—	—	—	—		
	3300 cfm	EAT (wb)	58	TC	87.5	87.5	99.1	82.7	82.7	93.9	77.7	77.7	88.3	72.5	72.5	82.6
				SHC	75.9	87.5	99.1	71.6	82.7	93.9	67.0	77.7	88.3	62.3	72.5	82.6
62			TC	87.6	87.6	103.2	82.8	82.8	97.7	77.8	77.8	92.0	72.5	72.5	86.0	
			SHC	72.1	87.6	103.2	67.9	82.8	97.7	63.6	77.8	92.0	59.0	72.5	86.0	
67			TC	93.9	93.9	93.9	87.9	87.9	90.2	81.8	81.8	87.1	75.4	75.4	83.9	
			SHC	58.2	75.7	93.3	55.2	72.8	90.2	52.2	69.6	87.1	49.0	66.4	83.9	
72		TC	103.8	103.8	103.8	97.3	97.3	97.3	90.8	90.8	90.8	84.0	84.0	84.0		
		SHC	40.7	58.3	75.9	37.6	55.2	72.9	34.6	52.2	69.7	31.4	49.0	66.5		
76		TC	—	—	—	—	—	—	—	—	—	—	—	—		
		SHC	—	—	—	—	—	—	—	—	—	—	—	—		
3700 cfm		EAT (wb)	58	TC	90.7	90.7	102.7	85.7	85.7	97.2	80.5	80.5	91.5	75.0	75.0	85.4
				SHC	78.7	90.7	102.7	74.3	85.7	97.2	69.5	80.5	91.5	64.5	75.0	85.4
	62		TC	90.8	90.8	106.8	85.8	85.8	101.2	80.6	80.6	95.2	75.1	75.1	89.0	
			SHC	74.8	90.8	106.8	70.5	85.8	101.2	65.9	80.6	95.2	61.2	75.1	89.0	
	67		TC	95.3	95.3	100.7	89.3	89.3	97.6	83.1	83.1	94.3	76.6	76.6	91.0	
			SHC	61.7	81.2	100.7	58.6	78.1	97.6	55.5	74.9	94.3	52.4	71.7	91.0	
	72	TC	105.2	105.2	105.2	98.7	98.7	98.7	92.0	92.0	92.0	—	—	—		
		SHC	41.8	61.4	81.1	38.7	58.3	77.9	35.6	55.2	74.8	—	—	—		
	76	TC	—	—	—	—	—	—	—	—	—	—	—	—		
		SHC	—	—	—	—	—	—	—	—	—	—	—	—		

### LEGEND

- Do Not Operate
- cfm — Cubic Feet Per Minute (Supply Air)
- EAT (db) — Entering Air Temperature (dry bulb)
- EAT (wb) — Entering Air Temperature (wet bulb)
- SHC — Sensible Heat Capacity (1000 Btuh) Gross
- TC — Total Capacity (1000 Btuh) Gross

NOTE: See minimum-maximum airflow ratings on page 8.

## 48/50FC\*N14 — UNIT WITH HUMIDI-MIZER® SYSTEM IN SUBCOOLING MODE — COOLING CAPACITIES

TEMP (F) AIR ENTERING CONDENSER (Edb)		AIR ENTERING EVAPORATOR — SCFM/BF (80 F db)								
		3750/0.11			5000/0.13			6250/0.15		
		Air Entering Evaporator — Ewb (F)								
		72	67	62	72	67	62	72	67	62
75	TC	157.0	140.0	127.0	165.0	150.0	135.0	172.0	156.0	141.0
	SHC	64.0	82.0	101.0	74.0	99.0	122.0	85.0	114.0	138.0
	kW	12.4	12.0	11.8	12.6	12.3	12.0	12.8	12.4	12.1
85	TC	137.0	132.0	118.0	144.0	141.0	127.0	151.0	132.0	133.0
	SHC	46.0	75.0	93.0	55.0	91.0	114.0	66.0	92.0	129.0
	kW	13.0	13.1	12.8	13.2	13.4	13.0	13.4	12.9	13.2
95	TC	137.0	122.0	110.0	145.0	129.0	117.0	150.0	134.0	123.0
	SHC	47.0	66.0	86.0	57.0	80.0	105.0	66.0	95.0	120.0
	kW	14.7	14.3	14.0	14.9	14.5	14.2	15.0	14.6	14.3
105	TC	127.0	113.0	103.0	134.0	120.0	108.0	139.0	125.0	114.0
	SHC	39.0	58.0	74.0	48.0	73.0	97.0	56.0	86.0	110.0
	kW	15.9	15.6	15.3	16.1	15.8	15.5	16.3	15.9	15.6
115	TC	116.0	103.0	94.0	123.0	110.0	98.0	127.0	114.0	103.0
	SHC	29.0	50.0	66.0	38.0	64.0	89.0	46.0	76.0	102.0
	kW	17.3	16.9	11.7	17.5	17.1	16.8	17.6	17.2	16.9

## 48/50FC\*N14 — UNIT WITH HUMIDI-MIZER SYSTEM IN HOT GAS REHEAT MODE — COOLING CAPACITIES

TEMP (F) AIR ENTERING CONDENSER (Edb)		AIR ENTERING EVAPORATOR — Ewb (F)								
		75 Dry Bulb 62.5 Wet Bulb (50% Relative)			75 Dry Bulb 64 Wet Bulb (56% Relative)			75 Dry Bulb 65.3 Wet Bulb (60% Relative)		
		Air Entering Evaporator — cfm								
		3750	5000	6250	3750	5000	6250	3750	5000	6250
80	TC	54.0	59.0	62.0	56.0	61.0	64.0	58.0	63.0	66.0
	SHC	9.0	20.0	31.0	3.0	12.0	21.0	-3.0	5.0	13.0
	kW	10.9	11.0	11.1	11.0	11.1	11.1	11.0	11.1	11.2
75	TC	57.0	62.0	65.0	60.0	65.0	68.0	62.0	67.0	70.0
	SHC	13.0	24.0	35.0	7.0	16.0	25.0	2.0	9.0	17.0
	kW	10.5	10.6	10.6	10.6	10.6	10.7	10.6	10.7	10.8
70	TC	61.0	66.0	69.0	63.0	68.0	72.0	66.0	71.0	74.0
	SHC	17.0	28.0	39.0	12.0	21.0	30.0	7.0	15.0	22.0
	kW	10.1	10.2	10.3	10.2	10.3	10.3	10.2	10.3	10.4
60	TC	62.0	67.0	70.0	64.0	69.0	72.0	66.0	71.0	74.0
	SHC	16.0	27.0	38.0	10.0	19.0	28.0	4.0	12.0	20.0
	kW	11.0	11.3	11.5	11.1	11.4	11.6	11.3	11.5	11.7
50	TC	69.0	74.0	77.0	71.0	76.0	80.0	73.0	79.0	82.0
	SHC	23.0	34.0	45.0	17.0	26.0	35.0	11.0	19.0	27.0
	kW	10.2	10.4	10.6	10.3	10.5	10.7	10.4	10.7	10.8
40	TC	75.0	80.0	84.0	78.0	83.0	87.0	80.0	86.0	89.0
	SHC	31.0	41.0	52.0	25.0	34.0	43.0	19.0	27.0	35.0
	kW	9.4	9.7	9.8	9.6	9.8	10.0	9.7	9.9	10.1

### LEGEND

- Ewb** — Entering wet bulb
- kW** — compressor Power Input
- SCFM/BF** — Standard Cubic Feet per Minute/Bypass Factor
- SHC** — Sensible Heat Capacity (1000 Btuh) Gross
- TC** — Total Capacity (1000 Btuh) Gross

## 48/50FC\*\*16 TWO STAGE COOLING CAPACITIES

48/50FC**16				AMBIENT TEMPERATURE (F)												
				85			95			105			115			
				EAT (db)			EAT (db)			EAT (db)			EAT (db)			
				75	80	85	75	80	85	75	80	85	75	80	85	
4500 cfm	EAT (wb)	58	TC	159.2	159.2	175.8	148.5	148.5	169.0	139.2	139.2	158.8	129.5	129.5	148.1	
			SHC	134.9	155.4	175.8	128.1	148.5	169.0	119.6	139.2	158.8	110.8	129.5	148.1	
		62	TC	167.4	167.4	167.7	156.4	156.4	161.3	145.1	145.1	154.6	133.1	133.1	147.5	
			SHC	121.7	144.7	167.7	115.2	138.2	161.3	108.5	131.5	154.6	101.6	124.5	147.5	
		67	TC	185.3	185.3	185.3	173.6	173.6	173.6	161.4	161.4	161.4	148.7	148.7	148.7	
			SHC	99.0	121.9	144.7	92.5	115.4	138.3	85.9	108.9	131.8	79.1	102.1	125.1	
	72	TC	205.2	205.2	205.2	192.5	192.5	192.5	179.4	179.4	179.4	165.9	165.9	165.9		
		SHC	76.7	98.8	120.9	70.0	92.3	114.7	63.3	85.8	108.3	56.5	79.1	101.8		
	76	TC	—	223.0	223.0	—	209.2	209.2	—	195.2	195.2	—	180.9	180.9		
		SHC	—	78.7	103.5	—	73.1	97.8	—	66.9	84.3	—	60.4	81.0		
	5250 cfm	EAT (wb)	58	TC	167.2	167.2	189.6	157.7	157.7	179.2	147.8	147.8	168.4	137.4	137.4	157.0
				SHC	144.8	167.2	189.6	136.2	157.7	179.2	127.2	147.8	168.4	117.8	137.4	157.0
62			TC	173.3	173.3	185.3	161.8	161.8	178.3	150.0	150.0	171.1	138.5	138.5	162.1	
			SHC	132.4	158.8	185.3	125.5	151.9	178.3	118.6	144.8	171.1	110.7	136.4	162.1	
67			TC	191.2	191.2	191.2	178.9	178.9	178.9	166.2	166.2	166.2	153.0	153.0	153.0	
			SHC	106.2	132.6	159.0	99.6	126.0	152.5	92.8	119.3	145.8	85.9	112.5	139.0	
72		TC	211.1	211.1	211.1	197.9	197.9	197.9	184.3	184.3	184.3	170.3	170.3	170.3		
		SHC	79.9	105.8	131.6	73.2	99.2	125.3	66.4	92.6	118.7	59.6	85.8	112.1		
76		TC	—	228.5	228.5	—	214.6	214.6	—	200.1	200.1	—	185.3	185.3		
		SHC	—	83.8	112.7	—	77.5	100.7	—	70.9	95.2	—	64.3	89.4		
6000 cfm		EAT (wb)	58	TC	175.3	175.3	198.7	165.4	165.4	187.8	154.9	154.9	176.4	144.1	144.1	164.4
				SHC	152.0	175.3	198.7	143.0	165.4	187.8	133.5	154.9	176.4	123.7	144.1	164.4
	62		TC	178.0	178.0	201.2	166.7	166.7	193.0	157.0	157.0	179.3	147.0	147.0	165.2	
			SHC	142.0	171.6	201.2	134.6	163.8	193.0	124.6	152.0	179.3	114.3	139.8	165.2	
	67		TC	195.7	195.7	195.7	183.1	183.1	183.1	169.9	169.9	169.9	156.3	156.3	156.3	
			SHC	112.8	142.7	172.7	106.1	136.1	166.0	99.3	129.3	159.2	92.4	122.3	152.3	
	72	TC	215.7	215.7	215.7	202.1	202.1	202.1	188.1	188.1	188.1	173.6	173.6	173.6		
		SHC	82.9	112.4	141.8	76.2	105.8	135.3	69.4	99.0	128.7	62.5	92.2	122.0		
	76	TC	—	233.3	233.3	—	218.9	218.9	—	203.9	203.9	—	188.5	188.5		
		SHC	—	87.8	114.8	—	81.3	109.1	—	74.7	103.1	—	67.9	96.7		
	6750 cfm	EAT (wb)	58	TC	182.2	182.2	206.3	171.8	171.8	194.9	160.9	160.9	183.0	149.5	149.5	170.5
				SHC	158.1	182.2	206.3	148.7	171.8	194.9	138.8	160.9	183.0	128.6	149.5	170.5
62			TC	183.3	183.3	212.5	172.6	172.6	200.6	162.9	162.9	185.9	149.8	149.8	177.8	
			SHC	149.2	180.9	212.5	140.0	170.3	200.6	129.5	157.7	185.9	121.7	149.8	177.8	
67			TC	199.4	199.4	199.4	186.3	186.3	186.3	172.8	172.8	172.8	158.9	158.9	164.9	
			SHC	119.2	152.4	185.7	112.4	145.7	179.0	105.4	138.7	172.0	98.4	131.7	164.9	
72		TC	219.3	219.3	219.3	205.4	205.4	205.4	191.1	191.1	191.1	176.1	176.1	176.1		
		SHC	85.8	118.7	151.6	79.0	112.0	145.0	72.1	105.2	138.3	65.1	98.3	131.4		
76		TC	—	237.0	237.0	—	222.1	222.1	—	206.8	206.8	—	191.1	191.1		
		SHC	—	91.4	122.5	—	84.8	116.5	—	78.0	110.2	—	71.2	103.6		
7500 cfm		EAT (wb)	58	TC	188.1	188.1	212.8	177.2	177.2	201.0	165.9	165.9	188.6	154.3	154.3	175.8
				SHC	163.3	188.1	212.8	153.5	177.2	201.0	143.3	165.9	188.6	132.8	154.3	175.8
	62		TC	191.5	191.5	214.2	177.5	177.5	209.2	166.2	166.2	196.4	154.4	154.4	183.1	
			SHC	152.0	183.1	214.2	145.8	177.5	209.2	135.9	166.2	196.4	125.7	154.4	183.1	
	67		TC	202.3	202.3	202.3	189.0	189.0	191.4	175.2	175.2	184.4	161.2	161.2	177.1	
			SHC	125.2	161.7	198.3	118.3	154.9	191.4	111.3	147.9	184.4	104.2	140.7	177.1	
	72	TC	222.3	222.3	222.3	208.1	208.1	208.1	193.3	193.3	193.3	178.3	178.3	178.3		
		SHC	88.4	124.7	161.0	81.6	118.0	154.3	74.7	111.1	147.5	67.7	104.2	140.7		
	76	TC	—	239.8	239.8	—	224.7	224.7	—	209.2	209.2	—	—	—		
		SHC	—	94.7	129.6	—	88.1	123.4	—	81.3	116.9	—	—	—		

### LEGEND

- Do Not Operate
- cfm — Cubic Feet Per Minute (Supply Air)
- EAT (db) — Entering Air Temperature (dry bulb)
- EAT (wb) — Entering Air Temperature (wet bulb)
- SHC — Sensible Heat Capacity (1000 Btuh) Gross
- TC — Total Capacity (1000 Btuh) Gross

NOTE: See minimum-maximum airflow ratings on page 8.

## 48/50FC\*\*16 SINGLE STAGE COOLING CAPACITIES

48/50FC**16				AMBIENT TEMPERATURE (F)												
				85			95			105			115			
				EAT (db)			EAT (db)			EAT (db)			EAT (db)			
				75	80	85	75	80	85	75	80	85	75	80	85	
2500 cfm	EAT (wb)	58	TC	93.5	93.5	102.9	85.6	85.6	96.7	77.6	77.6	89.9	69.9	69.9	82.2	
			SHC	76.9	89.9	102.9	70.8	83.8	96.7	64.5	77.2	89.9	57.7	69.9	82.2	
		62	TC	103.3	103.3	103.3	94.9	94.9	94.9	86.2	86.2	86.2	77.1	77.1	77.1	
			SHC	68.1	81.1	94.1	62.2	75.2	88.2	56.2	69.2	82.2	50.0	63.1	76.1	
		67	TC	116.8	116.8	116.8	108.0	108.0	108.0	98.8	98.8	98.8	89.2	89.2	89.2	
			SHC	57.0	69.8	82.6	51.1	63.9	76.8	45.1	57.9	70.8	38.9	51.8	64.7	
	72	TC	131.3	131.3	131.3	122.1	122.1	122.1	112.4	112.4	112.4	102.3	102.3	102.3		
		SHC	46.4	58.1	69.8	40.2	52.4	64.6	34.0	46.5	58.9	27.8	40.4	53.0		
	76	TC	—	143.3	143.3	—	134.3	134.3	—	124.2	124.2	—	113.6	113.6		
		SHC	—	49.6	63.0	—	43.3	57	—	37.3	51.0	—	31.1	44.9		
	2900 cfm	EAT (wb)	58	TC	99.9	99.9	112.5	92.0	92.0	106.1	84.1	84.1	97.5	76.3	76.3	89.1
				SHC	84.0	98.3	112.5	77.9	92.0	106.1	70.5	84.0	97.5	63.2	76.1	89.1
62			TC	108.4	108.4	108.4	99.6	99.6	99.6	90.4	90.4	92.5	80.9	80.9	86.2	
			SHC	74.8	89.8	104.8	68.7	83.7	98.7	62.6	77.5	92.5	56.2	71.2	86.2	
67			TC	122.0	122.0	122.0	112.8	112.8	112.8	103.1	103.1	103.1	93.1	93.1	93.1	
			SHC	61.6	76.4	91.2	55.6	70.4	85.2	49.4	64.3	79.1	43.1	58.0	72.9	
72		TC	136.8	136.8	136.8	127.1	127.1	127.1	117.0	117.0	117.0	106.4	106.4	106.4		
		SHC	48.6	62.8	77.0	42.5	56.9	71.3	36.3	50.8	65.3	29.9	44.6	59.2		
76		TC	—	149.7	149.7	—	139.8	139.8	—	129.1	129.1	—	117.8	117.8		
		SHC	—	51.9	67.8	—	45.6	61.6	—	39.7	55.6	—	33.6	46.0		
3300 cfm		EAT (wb)	58	TC	105.5	105.5	120.7	98.1	98.1	112.8	89.8	89.8	104.0	81.5	81.5	95.1
				SHC	90.2	105.5	120.7	83.3	98.1	112.8	75.7	89.8	104.0	68.0	81.5	95.1
	62		TC	112.4	112.4	114.8	103.3	103.3	108.6	93.8	93.8	102.2	84.0	84.0	95.5	
			SHC	81.0	97.9	114.8	74.8	91.7	108.6	68.5	85.4	102.2	61.9	78.7	95.5	
	67		TC	126.2	126.2	126.2	116.6	116.6	116.6	106.6	106.6	106.6	96.2	96.2	96.2	
			SHC	65.8	82.6	99.3	59.7	76.4	93.2	53.4	70.2	87.0	47.0	63.8	80.6	
	72	TC	141.2	141.2	141.2	131.1	131.1	131.1	120.5	120.5	120.5	109.6	109.6	109.6		
		SHC	50.7	67.1	83.4	44.5	61.0	77.4	38.3	54.8	71.3	31.8	48.4	65.0		
	76	TC	—	154.5	154.5	—	143.7	143.7	—	132.6	132.6	—	121.0	121		
		SHC	—	54.2	72.3	—	48.3	66.5	—	42.3	57.0	—	36.0	51.5		
	3700 cfm	EAT (wb)	58	TC	111.0	111.0	126.9	103.4	103.4	118.7	95.2	95.2	109.9	86.6	86.6	100.6
				SHC	95.2	111.0	126.9	88.1	103.4	118.7	80.5	95.2	109.9	72.5	86.6	100.6
62			TC	115.8	115.8	124.4	106.3	106.3	117.9	96.7	96.7	111.1	86.9	86.9	103.6	
			SHC	86.9	105.6	124.4	80.5	99.2	117.9	73.9	92.5	111.1	67.0	85.3	103.6	
67			TC	129.6	129.6	129.6	119.6	119.6	119.6	109.4	109.4	109.4	98.8	98.8	98.8	
			SHC	69.8	88.5	107.1	63.5	82.2	100.9	57.2	75.9	94.6	50.7	69.4	88.1	
72		TC	144.7	144.7	144.7	134.3	134.3	134.3	123.4	123.4	123.4	112.2	112.2	112.2		
		SHC	52.7	71.0	89.3	46.4	64.8	83.2	40.1	58.5	76.9	33.6	52.0	70.5		
76		TC	—	157.8	157.8	—	146.8	146.8	—	135.4	135.4	—	123.4	123.4		
		SHC	—	56.8	72.4	—	50.7	67.5	—	44.4	61.8	—	38.0	55.7		
4150 cfm		EAT (wb)	58	TC	116.5	116.5	132.9	108.2	108.2	124.0	99.6	99.6	114.8	90.6	90.6	105.1
				SHC	100.0	116.5	132.9	92.3	108.2	124.0	84.4	99.6	114.8	76.1	90.6	105.1
	62		TC	119.0	119.0	134.2	109.6	109.6	127.2	100.3	100.3	118.6	91.5	91.5	108.3	
			SHC	92.9	113.5	134.2	86.3	106.8	127.2	78.8	98.7	118.6	70.6	89.5	108.3	
	67		TC	132.7	132.7	132.7	122.5	122.5	122.5	112.0	112.0	112.0	101.1	101.1	101.1	
			SHC	74.0	94.7	115.5	67.6	88.4	109.2	61.2	82.0	102.8	54.6	75.4	96.2	
	72	TC	147.9	147.9	147.9	137.2	137.2	137.2	126.1	126.1	126.1	114.5	114.5	114.5		
		SHC	54.7	75.1	95.6	48.4	68.8	89.3	41.9	62.4	82.9	35.4	55.9	76.4		
	76	TC	—	161.0	161.0	—	149.7	149.7	—	137.9	137.9	—	125.6	125.6		
		SHC	—	59.3	78.2	—	53.0	72.4	—	46.7	66.3	—	40.1	59.9		

**LEGEND**

- Do Not Operate
- cfm — Cubic Feet Per Minute (Supply Air)
- EAT (db) — Entering Air Temperature (dry bulb)
- EAT (wb) — Entering Air Temperature (wet bulb)
- SHC — Sensible Heat Capacity (1000 Btuh) Gross
- TC — Total Capacity (1000 Btuh) Gross

NOTE: See minimum-maximum airflow ratings on page 8.

## 48/50FC\*N16 — UNIT WITH HUMIDI-MIZER® SYSTEM IN SUBCOOLING MODE — COOLING CAPACITIES

TEMP (F) AIR ENTERING CONDENSER (Edb)		AIR ENTERING EVAPORATOR — SCFM/BF (80 F db)								
		4500/0.09			6000/0.12			7500/0.14		
		Air Entering Evaporator — Ewb (F)								
		72	67	62	72	67	62	72	67	62
75	TC	203.0	181.0	162.0	213.0	196.0	175.0	225.0	202.0	183.0
	SHC	82.0	103.0	124.0	93.0	125.0	152.0	109.0	142.0	175.0
	kW	14.1	13.7	13.4	14.2	14.1	13.7	14.5	14.1	13.8
85	TC	190.0	168.0	149.0	202.0	181.0	161.0	210.0	189.0	169.0
	SHC	70.0	91.0	113.0	83.0	112.0	139.0	95.0	130.0	162.0
	kW	15.3	14.9	14.6	15.5	15.2	14.8	15.7	15.3	14.9
95	TC	176.0	155.0	137.0	187.0	166.0	148.0	195.0	174.0	155.0
	SHC	57.0	79.0	102.0	70.0	98.0	127.0	81.0	117.0	149.0
	kW	16.6	16.2	15.9	16.9	16.5	16.1	17.0	16.7	16.3
105	TC	161.0	141.0	124.0	172.0	152.0	134.0	179.0	159.0	141.0
	SHC	44.0	67.0	90.0	56.0	85.0	114.0	67.0	103.0	135.0
	kW	18.1	17.7	17.4	18.4	17.9	17.6	18.5	18.1	17.8
115	TC	146.0	127.0	110.0	156.0	137.0	120.0	162.0	143.0	126.0
	SHC	31.0	54.0	78.0	42.0	73.0	101.0	52.0	89.0	121.0
	kW	19.8	19.4	19.1	20.0	19.7	19.3	20.2	19.8	19.4
125	TC	130.0	113.0	97.0	139.0	121.0	105.0	145.0	127.0	110.0
	SHC	18.0	42.0	65.0	28.0	59.0	88.0	37.0	75.0	106.0
	kW	21.6	21.2	20.8	21.8	21.4	21.0	21.9	21.6	21.1

## 48/50FC\*N16 — UNIT WITH HUMIDI-MIZER SYSTEM IN HOT GAS REHEAT MODE — COOLING CAPACITIES

TEMP (F) AIR ENTERING CONDENSER (Edb)		AIR ENTERING EVAPORATOR — Ewb (F)								
		75 Dry Bulb 62.5 Wet Bulb (50% Relative)			75 Dry Bulb 64 Wet Bulb (56% Relative)			75 Dry Bulb 65.3 Wet Bulb (60% Relative)		
		Air Entering Evaporator — cfm								
		4500	6000	7500	4500	6000	7500	4500	6000	7500
80	TC	60.0	63.0	65.0	64.0	66.0	68.0	67.0	68.0	70.0
	SHC	9.0	5.0	2.0	16.0	11.0	7.0	22.0	16.0	11.0
	kW	12.8	12.8	12.9	12.9	12.9	13.0	12.9	13.0	13.0
75	TC	63.0	66.0	68.0	67.0	69.0	71.0	70.0	72.0	74.0
	SHC	12.0	8.0	4.0	19.0	14.0	9.0	25.0	19.0	13.0
	kW	12.5	12.5	12.6	12.6	12.6	12.6	12.6	12.6	12.6
70	TC	66.0	69.0	71.0	70.0	73.0	74.0	73.0	75.0	77.0
	SHC	14.0	10.0	7.0	22.0	16.0	12.0	28.0	21.0	16.0
	kW	12.4	12.4	12.5	12.5	12.5	12.5	12.5	12.5	12.5
60	TC	72.0	74.0	77.0	76.0	79.0	80.0	79.0	81.0	83.0
	SHC	21.0	15.0	11.0	26.0	21.0	17.0	33.0	26.0	21.0
	kW	12.4	12.4	12.4	12.4	12.4	12.4	12.4	12.4	12.4
50	TC	77.0	80.0	82.0	82.0	84.0	86.0	85.0	87.0	89.0
	SHC	24.0	19.0	16.0	31.0	26.0	22.0	38.0	32.0	26.0
	kW	12.4	12.4	12.4	12.4	12.4	12.4	12.4	12.4	12.4
40	TC	82.0	85.0	87.0	87.0	90.0	92.0	90.0	92.0	95.0
	SHC	28.0	24.0	20.0	36.0	31.0	27.0	43.0	37.0	31.0
	kW	12.4	12.4	12.4	12.4	12.4	12.4	12.4	12.4	12.4

### LEGEND

- Ewb** — Entering wet bulb
- kW** — compressor Power Input
- SCFM/BF** — Standard Cubic Feet per Minute/Bypass Factor
- SHC** — Sensible Heat Capacity (1000 Btuh) Gross
- TC** — Total Capacity (1000 Btuh) Gross

## PRESSURE DROPS FOR ELECTRIC HEATING UNITS

### 7.5 AND 8.5 TON UNITS

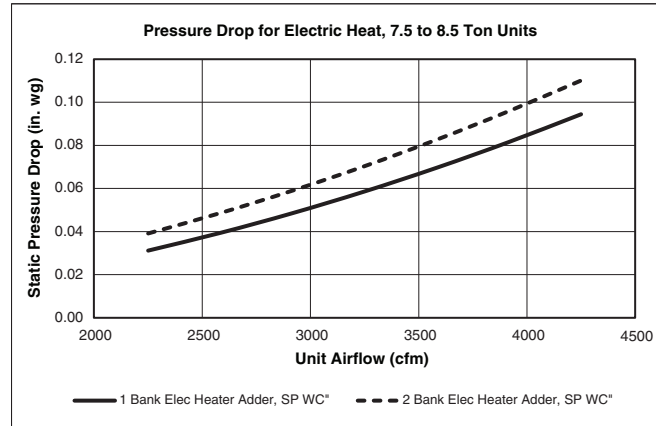

### 10 AND 12.5 TON UNITS

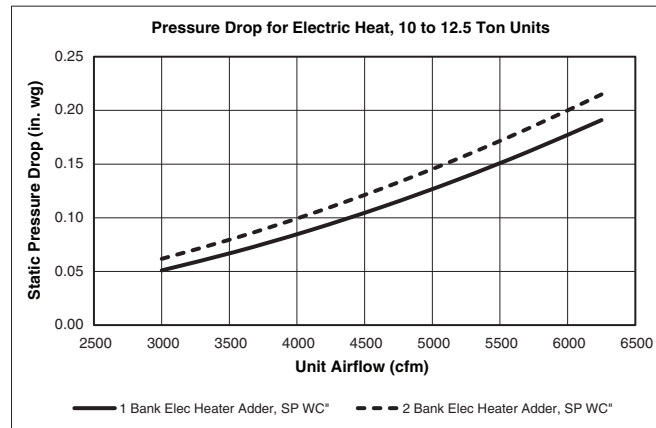

### 15 TON UNITS

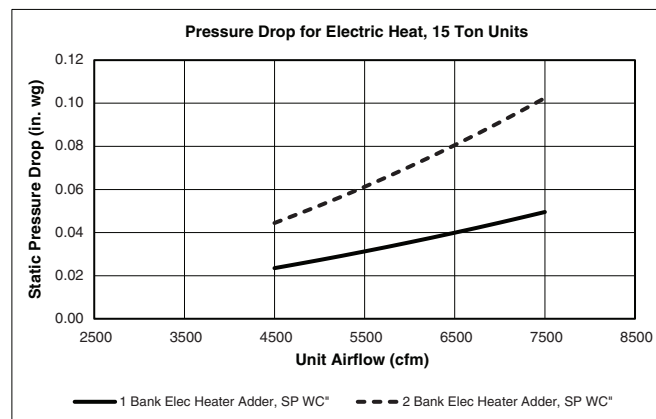

## PRESSURE DROPS FOR GAS HEATING UNITS

### GAS HEAT STAGES

48FC UNIT SIZE	HEAT SIZE		
	LOW	MEDIUM	HIGH
08	1	2	2
09	1	2	2
12	2	2	2
14	2	2	2
16	2	2	2

### GAS HEAT STATIC PRESSURE DEDUCTIONS — 7.5 TO 8.5 TON UNITS

CFM	2250	2585	2915	3250	3585	3915	4250
Medium Gas Heat Deduction	-0.04	-0.04	-0.03	-0.02	-0.02	-0.01	0.01
Low Gas Heat Deduction	0.01	0.01	0.02	0.04	0.05	0.06	0.08

### GAS HEAT STATIC PRESSURE DEDUCTIONS — 10 TO 12.5 TON UNITS

CFM	3000	3540	4085	4625	5165	5710	6250
Medium Gas Heat Deduction	0.00	0.02	0.04	0.06	0.08	0.11	0.15
Low Gas Heat Deduction	-0.03	0.00	0.04	0.08	0.13	0.20	0.27

### GAS HEAT STATIC PRESSURE DEDUCTIONS — 15 TON UNITS

CFM	4500	5000	5500	6000	6500	7000	7500
High Gas Heat Deduction	0.12	0.14	0.16	0.17	0.19	0.21	0.23
Medium Gas Heat Deduction	0.21	0.24	0.26	0.29	0.31	0.34	0.36
Low Gas Heat Deduction	0.20	0.22	0.25	0.27	0.29	0.32	0.34

## FIELD-INSTALLED ACCESSORY ELECTRIC HEATER DATA

50FC UNIT SIZE	VOLTAGE	HEATER MODEL NUMBER	NUMBER OF STAGES
08	208/230	CRHEATER411A00	1
		CRHEATER412A00	1
		CRHEATER414A00	2
		CRHEATER415A00	2
		CRHEATER416A00	2
	460	CRHEATER420A00	1
		CRHEATER421A00	2
		CRHEATER422A00	2
		CRHEATER423A00	2
	575	CRHEATER425A00	1
CRHEATER427A00		2	
09	208/230	CRHEATER411A00	1
		CRHEATER412A00	1
		CRHEATER414A00	2
		CRHEATER415A00	2
		CRHEATER416A00	2
	460	CRHEATER420A00	1
		CRHEATER421A00	2
		CRHEATER422A00	2
		CRHEATER423A00	2
	575	CRHEATER425A00	1
CRHEATER427A00		2	
12	208/230	CRHEATER411A00	1
		CRHEATER412A00	1
		CRHEATER415A00	2
		CRHEATER416A00	2
		CRHEATER417A00	2
	460	CRHEATER420A00	1
		CRHEATER422A00	2
		CRHEATER423A00	2
		CRHEATER424A00	2
	575	CRHEATER425A00	1
CRHEATER427A00		2	
		CRHEATER428A00	2
14	208/230	CRHEATER411A00	1
		CRHEATER412A00	1
		CRHEATER415A00	2
		CRHEATER416A00	2
		CRHEATER417A00	2
	460	CRHEATER420A00	1
		CRHEATER422A00	2
		CRHEATER423A00	2
		CRHEATER424A00	2
	575	CRHEATER425A00	1
CRHEATER427A00		2	
		CRHEATER428A00	2



# Performance data (cont)



## FIELD-INSTALLED ACCESSORY ELECTRIC HEATER DATA (CONT)

50FC UNIT SIZE	VOLTAGE	HEATER MODEL NUMBER	NUMBER OF STAGES
16	208/230	CRHEATER412A00	1
		CRHEATER414A00	2
		CRHEATER415A00	2
		CRHEATER416A00	2
		CRHEATER417A00	2
		CRHEATER451A00	2
	460	CRHEATER420A00	1
		CRHEATER421A00	2
		CRHEATER422A00	2
		CRHEATER423A00	2
		CRHEATER424A00	2
		CRHEATER452A00	1
	575	CRHEATER425A00	1
		CRHEATER427A00	2
		CRHEATER428A00	2
		CRHEATER453A00	2

## ECONOMIZER BAROMETRIC RELIEF AND DAMPER LEAKAGE — 7.5 TO 12.5 TON UNITS (SIZES 08-14)

### HORIZONTAL ECONOMIZER BAROMETRIC RELIEF

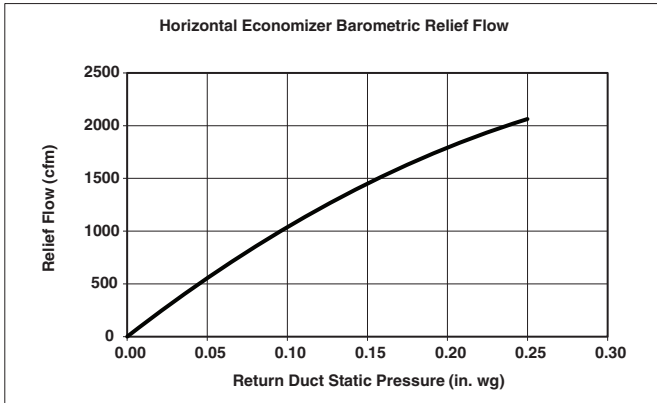

### VERTICAL ECONOMIZER BAROMETRIC RELIEF

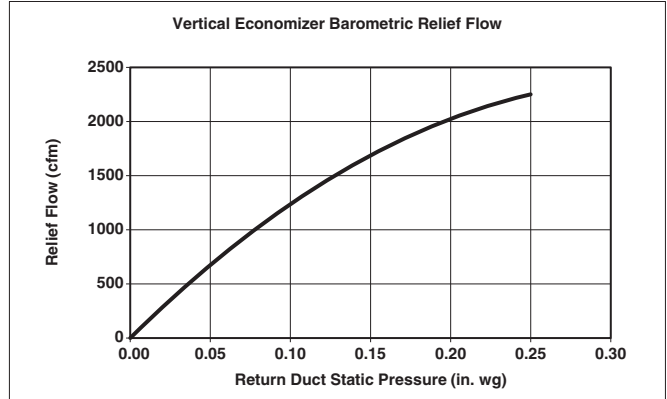

### HORIZONTAL ECONOMIZER DAMPER LEAKAGE

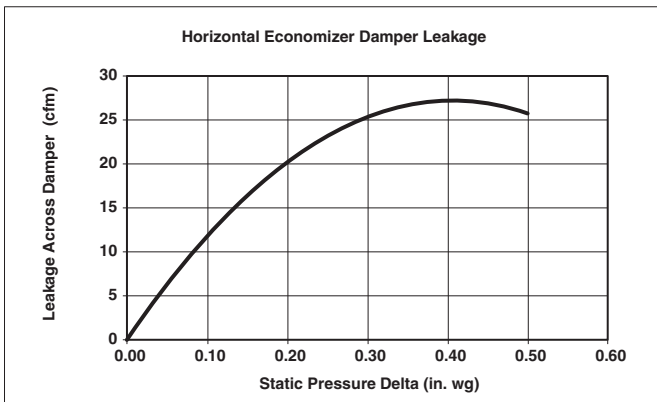

### VERTICAL ECONOMIZER DAMPER LEAKAGE

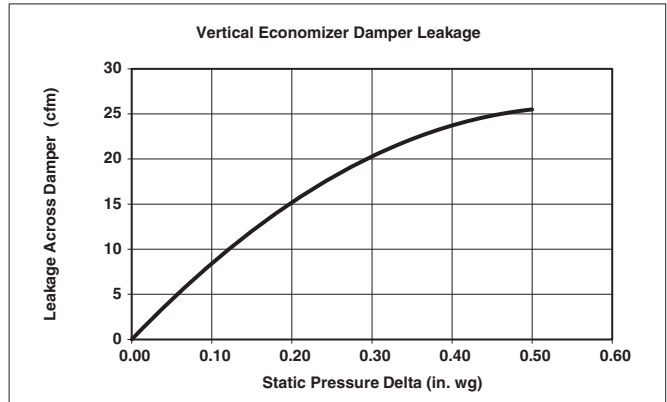

## ECONOMIZER BAROMETRIC RELIEF AND DAMPER LEAKAGE — 15 TON UNITS (SIZE 16)

### HORIZONTAL ECONOMIZER BAROMETRIC RELIEF

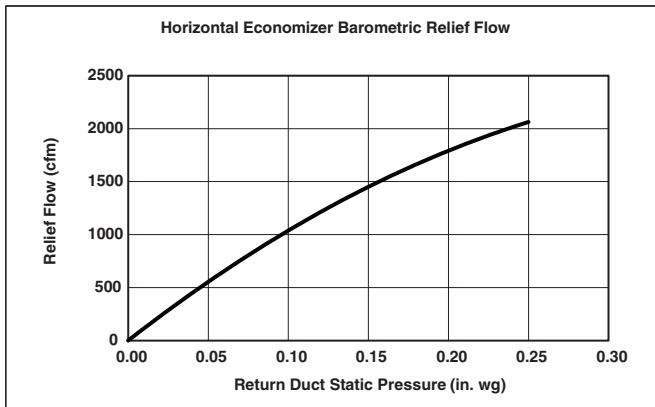

### VERTICAL ECONOMIZER BAROMETRIC RELIEF

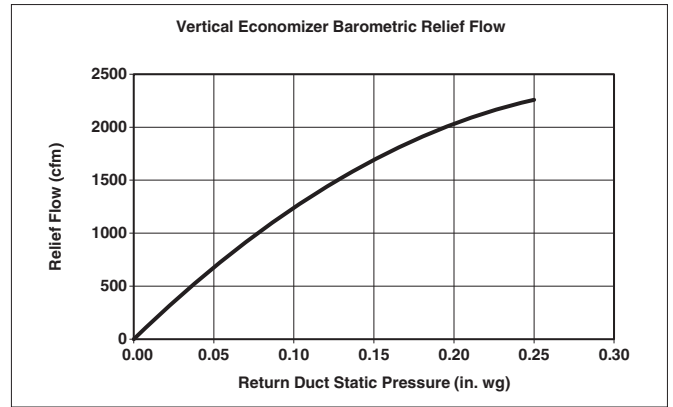

### HORIZONTAL ECONOMIZER DAMPER LEAKAGE

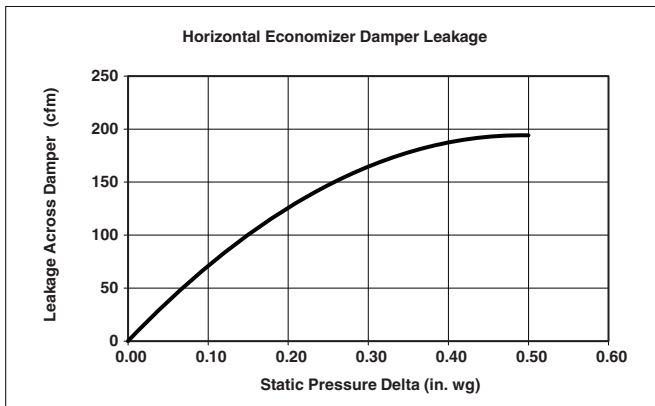

### VERTICAL ECONOMIZER DAMPER LEAKAGE

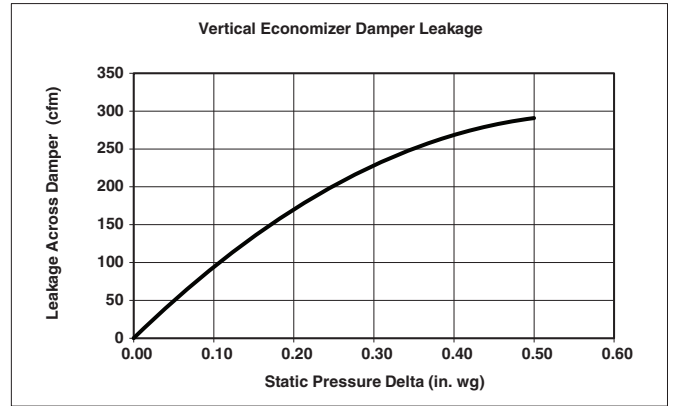

## ECONOMIZER PRESSURE DROP 7.5 TO 15 TON UNITS

### 7.5 to 12.5 TON UNITS (SIZES 08-14)

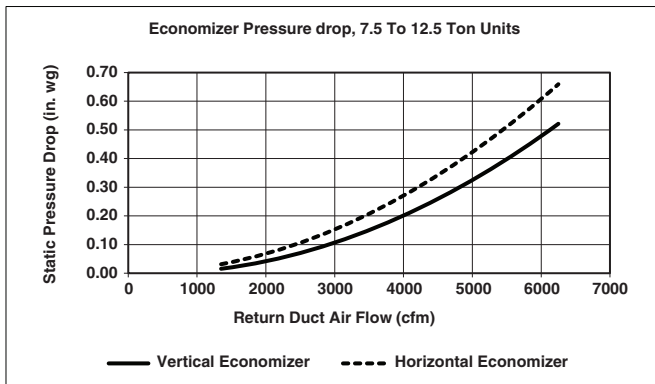

### 15 TON UNITS (SIZE 16)

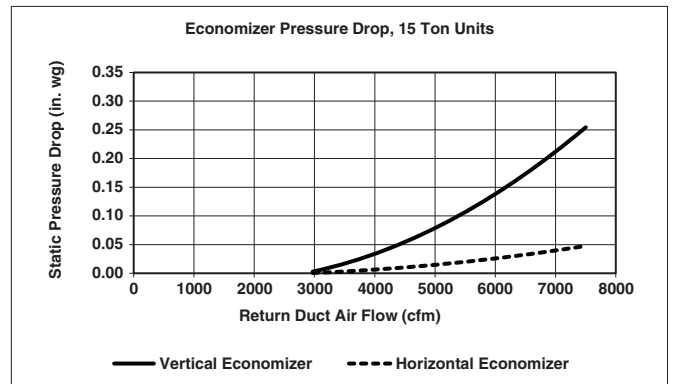

## HUMIDI-MIZER® COIL PRESSURE DROPS — 7.5 TO 15 TON UNITS

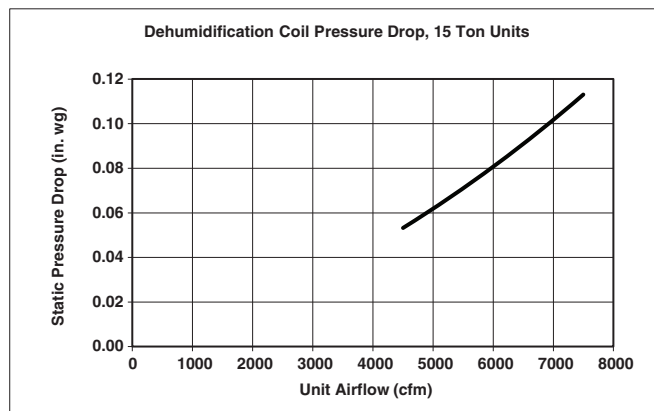
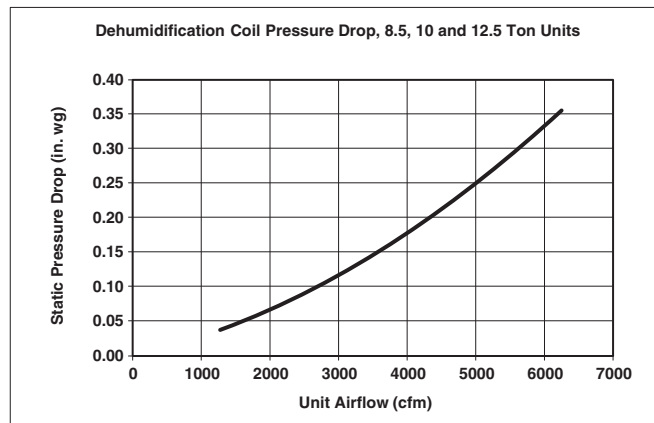
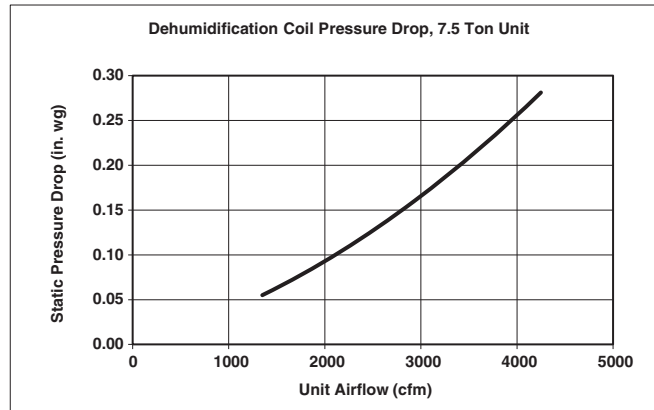

### MERV-13 filters pressure drop

NOTE: For 4-in. MERV-13 filter factory option, use Packaged RTU Builder program for associated pressure drop.

## GENERAL FAN PERFORMANCE NOTES

1. Interpolation is permissible. Do not extrapolate.
2. External static pressure is the static pressure difference between the return duct and the supply duct plus the static pressure caused by any FIOPs or accessories.
3. Tabular data accounts for pressure loss due to clean filters, unit casing, wet coils, and highest gas heat exchanger (when gas heat unit).
4. Factory options and accessories may effect static pressure losses. Gas heat unit fan tables assume highest gas heat models; for fan selections with low or medium heat models, the user must deduct low and medium heat static pressures. Selection software is available, through your salesperson, to help you select the best motor/drive combination for your application.
5. The fan performance tables offer motor/drive recommendations. In cases when two motor/drive combinations would work, the lower horsepower option is recommended.
6. For information on the electrical properties of the fan motors, please see the Electrical information section of this book.
7. For more information on the performance limits of the fan motors, see the application data section of this book.
8. The EPACT (Energy Policy Act of 1992) regulates energy requirements for specific types of indoor fan motors. Motors regulated by EPACT include any general purpose, T-frame (three-digit, 143 and larger), single-speed, foot mounted, polyphase, squirrel cage induction motors of NEMA (National Electrical Manufacturers Association) design A and B, manufactured for use in the United States. Ranging from 1 to 200 Hp, these continuous-duty motors operate on 230 and 460 volt, 60 Hz power. If a motor does not fit into these specifications, the motor does not have to be replaced by an EPACT compliant energy-efficient motor. Variable-speed motors are exempt from EPACT compliance requirements.

## 48FCFM08 — 7.5 TON VERTICAL SUPPLY (RPM - BHP)

CFM	AVAILABLE EXTERNAL STATIC PRESSURE (in. wg)									
	0.2		0.4		0.6		0.8		1.0	
	rpm	bhp	rpm	bhp	rpm	bhp	rpm	bhp	rpm	bhp
2250	1045	0.43	1166	0.60	1273	0.78	1372	0.97	1463	1.18
2440	1111	0.51	1226	0.69	1329	0.88	1424	1.08	1512	1.30
2625	1178	0.61	1288	0.80	1387	1.00	1478	1.21	1564	1.43
2810	1246	0.72	1351	0.91	1446	1.12	1534	1.34	1617	1.57
3000	1314	0.83	1415	1.04	1507	1.26	1592	1.48	1672	1.71
3190	1383	0.96	1480	1.17	1568	1.40	1651	1.63	1729	1.87
3375	1453	1.09	1545	1.31	1631	1.55	1711	1.78	1786	2.03
3560	1523	1.23	1612	1.46	1694	1.70	1772	1.94	1845	2.20
3750	1594	1.38	1679	1.62	1759	1.86	1834	2.11	1905	2.36

CFM	AVAILABLE EXTERNAL STATIC PRESSURE (in. wg)									
	1.2		1.4		1.6		1.8		2.0	
	rpm	bhp	rpm	bhp	rpm	bhp	rpm	bhp	rpm	bhp
2250	1548	1.40	1629	1.63	1706	1.87	1778	2.12	1848	2.38
2440	1595	1.52	1674	1.76	1749	2.01	1821	2.27	1889	2.53
2625	1645	1.66	1721	1.90	1794	2.16	1865	2.42	1932	2.69
2810	1696	1.81	1770	2.06	1842	2.32	1910	2.58	1976	2.86
3000	1748	1.96	1821	2.22	1891	2.48	1958	2.75	2022	3.03
3190	1803	2.12	1873	2.38	1941	2.65	2007	2.93	—	—
3375	1858	2.29	1927	2.55	1994	2.83	2058	3.11	—	—
3560	1915	2.45	1982	2.72	2047	3.00	—	—	—	—
3750	1973	2.62	2039	2.90	2102	3.17	—	—	—	—

Std/Med Static 1045-2000 rpm, 2.4 Max bhp

High Static 1045-2200 rpm, 3.0 Max bhp

## 48FCFM08 – STANDARD/MEDIUM STATIC — 7.5 TON VERTICAL SUPPLY (RPM - VDC)

CFM	AVAILABLE EXTERNAL STATIC PRESSURE (in. wg)									
	0.2		0.4		0.6		0.8		1.0	
	rpm	Vdc	rpm	Vdc	rpm	Vdc	rpm	Vdc	rpm	Vdc
2250	1045	5.1	1166	5.7	1273	6.3	1372	6.8	1463	7.2
2440	1111	5.4	1226	6.0	1329	6.5	1424	7.0	1512	7.5
2625	1178	5.8	1288	6.3	1387	6.8	1478	7.3	1564	7.8
2810	1246	6.1	1351	6.7	1446	7.2	1534	7.6	1617	8.0
3000	1314	6.5	1415	7.0	1507	7.5	1592	7.9	1672	8.3
3190	1383	6.8	1480	7.3	1568	7.8	1651	8.2	1729	8.6
3375	1453	7.2	1545	7.7	1631	8.1	1711	8.5	1786	8.9
3560	1523	7.5	1612	8.0	1694	8.4	1772	8.8	1845	9.2
3750	1594	7.9	1679	8.3	1759	8.8	1834	9.1	1905	9.5

CFM	AVAILABLE EXTERNAL STATIC PRESSURE (in. wg)									
	1.2		1.4		1.6		1.8		2.0	
	rpm	Vdc	rpm	Vdc	rpm	Vdc	rpm	Vdc	rpm	Vdc
2250	1548	7.7	1629	8.1	1706	8.5	1778	8.9	1848	9.2
2440	1595	7.9	1674	8.3	1749	8.7	1821	9.1	—	—
2625	1645	8.2	1721	8.6	1794	8.9	—	—	—	—
2810	1696	8.4	1770	8.8	1842	9.2	—	—	—	—
3000	1748	8.7	1821	9.1	—	—	—	—	—	—
3190	1803	9.0	1873	9.3	—	—	—	—	—	—
3375	1858	9.3	—	—	—	—	—	—	—	—
3560	—	—	—	—	—	—	—	—	—	—
3750	—	—	—	—	—	—	—	—	—	—

Std/Med Static 1045-2000 rpm

## 48FCFM08 – HIGH STATIC — 7.5 TON VERTICAL SUPPLY (RPM - VDC)

CFM	AVAILABLE EXTERNAL STATIC PRESSURE (in. wg)									
	0.2		0.4		0.6		0.8		1.0	
	rpm	Vdc	rpm	Vdc	rpm	Vdc	rpm	Vdc	rpm	Vdc
2250	1045	4.7	1166	5.2	1273	5.7	1372	6.2	1463	6.6
2440	1111	5.0	1226	5.5	1329	6.0	1424	6.4	1512	6.8
2625	1178	5.3	1288	5.8	1387	6.2	1478	6.7	1564	7.1
2810	1246	5.6	1351	6.1	1446	6.5	1534	6.9	1617	7.3
3000	1314	5.9	1415	6.4	1507	6.8	1592	7.2	1672	7.6
3190	1383	6.2	1480	6.7	1568	7.1	1651	7.5	1729	7.8
3375	1453	6.6	1545	7.0	1631	7.4	1711	7.7	1786	8.1
3560	1523	6.9	1612	7.3	1694	7.7	1772	8.0	1845	8.4
3750	1594	7.2	1679	7.6	1759	8.0	1834	8.3	1905	8.6

CFM	AVAILABLE EXTERNAL STATIC PRESSURE (in. wg)									
	1.2		1.4		1.6		1.8		2.0	
	rpm	Vdc	rpm	Vdc	rpm	Vdc	rpm	Vdc	rpm	Vdc
2250	1548	7.0	1629	7.4	1706	7.7	1778	8.1	1848	8.4
2440	1595	7.2	1674	7.6	1749	7.9	1821	8.3	1889	8.6
2625	1645	7.4	1721	7.8	1794	8.1	1865	8.5	1932	8.8
2810	1696	7.7	1770	8.0	1842	8.3	1910	8.7	1976	9.0
3000	1748	7.9	1821	8.3	1891	8.6	1958	8.9	2022	9.2
3190	1803	8.2	1873	8.5	1941	8.8	2007	9.1	—	—
3375	1858	8.4	1927	8.7	1994	9.0	2058	9.3	—	—
3560	1915	8.7	1982	9.0	2047	9.3	—	—	—	—
3750	1973	9.0	2039	9.3	2102	9.5	—	—	—	—

High Static 1045-2200 rpm

## 48FCFM09 — 8.5 TON VERTICAL SUPPLY (RPM - BHP)

CFM	AVAILABLE EXTERNAL STATIC PRESSURE (in. wg)									
	0.2		0.4		0.6		0.8		1.0	
	rpm	bhp	rpm	bhp	rpm	bhp	rpm	bhp	rpm	bhp
2550	1091	0.48	1198	0.63	1298	0.81	1391	0.99	1478	1.19
2760	1164	0.58	1264	0.74	1359	0.92	1448	1.11	1532	1.31
2975	1238	0.69	1332	0.85	1422	1.04	1507	1.24	1588	1.45
3190	1312	0.81	1402	0.98	1487	1.17	1569	1.38	1646	1.59
3400	1388	0.94	1473	1.12	1554	1.32	1632	1.53	1706	1.75
3610	1464	1.08	1544	1.27	1622	1.47	1696	1.69	1768	1.91
3825	1541	1.24	1617	1.43	1691	1.64	1762	1.85	1831	2.08
4040	1618	1.40	1691	1.59	1761	1.80	1830	2.02	1896	2.25
4250	1696	1.56	1765	1.76	1832	1.97	1898	2.19	1962	2.42

CFM	AVAILABLE EXTERNAL STATIC PRESSURE (in. wg)									
	1.2		1.4		1.6		1.8		2.0	
	rpm	bhp	rpm	bhp	rpm	bhp	rpm	bhp	rpm	bhp
2550	1559	1.40	1636	1.61	1709	1.84	1779	2.08	1846	2.32
2760	1611	1.53	1686	1.75	1758	1.98	1826	2.22	1892	2.47
2975	1665	1.67	1738	1.90	1808	2.14	1875	2.38	1939	2.63
3190	1721	1.82	1792	2.05	1860	2.30	1925	2.55	1988	2.80
3400	1778	1.98	1847	2.22	1913	2.46	1977	2.72	2039	2.98
3610	1837	2.14	1904	2.38	1969	2.64	2031	2.89	2091	3.16
3825	1898	2.31	1963	2.56	2026	2.81	2086	3.07	—	—
4040	1961	2.49	2023	2.73	2084	2.98	—	—	—	—
4250	2024	2.66	2085	2.90	2144	3.16	—	—	—	—

Std/Med Static 1091-2000 rpm, 2.4 Max bhp

High Static 1091-2200 rpm, 3.0 Max bhp

## 48FCFM09 – STANDARD/MEDIUM STATIC — 8.5 TON VERTICAL SUPPLY (RPM - VDC)

CFM	AVAILABLE EXTERNAL STATIC PRESSURE (in. wg)									
	0.2		0.4		0.6		0.8		1.0	
	rpm	Vdc	rpm	Vdc	rpm	Vdc	rpm	Vdc	rpm	Vdc
2250	1091	5.3	1198	5.9	1298	6.4	1391	6.9	1478	7.3
2440	1164	5.7	1264	6.2	1359	6.7	1448	7.2	1532	7.6
2625	1238	6.1	1332	6.6	1422	7.0	1507	7.5	1588	7.9
2810	1312	6.5	1402	6.9	1487	7.4	1569	7.8	1646	8.2
3000	1388	6.9	1473	7.3	1554	7.7	1632	8.1	1706	8.5
3190	1464	7.2	1544	7.7	1622	8.1	1696	8.4	1768	8.8
3375	1541	7.6	1617	8.0	1691	8.4	1762	8.8	1831	9.1
3560	1618	8.0	1691	8.4	1761	8.8	1830	9.1	1896	9.5
3750	1696	8.4	1765	8.8	1832	9.1	1898	9.5	1962	9.8

CFM	AVAILABLE EXTERNAL STATIC PRESSURE (in. wg)									
	1.2		1.4		1.6		1.8		2.0	
	rpm	Vdc	rpm	Vdc	rpm	Vdc	rpm	Vdc	rpm	Vdc
2550	1559	7.7	1636	8.1	1709	8.5	1779	8.9	1846	9.2
2760	1611	8.0	1686	8.4	1758	8.8	1826	9.1	—	—
2975	1665	8.3	1738	8.7	1808	9.0	1875	9.4	—	—
3190	1721	8.6	1792	8.9	1860	9.3	—	—	—	—
3400	1778	8.9	1847	9.2	—	—	—	—	—	—
3610	1837	9.2	1904	9.5	—	—	—	—	—	—
3825	1898	9.5	—	—	—	—	—	—	—	—
4040	—	—	—	—	—	—	—	—	—	—
4250	—	—	—	—	—	—	—	—	—	—

Std/Med Static 1091-2000 rpm



## 48FCFM09 – HIGH STATIC — 8.5 TON VERTICAL SUPPLY (RPM - VDC)

CFM	AVAILABLE EXTERNAL STATIC PRESSURE (in. wg)									
	0.2		0.4		0.6		0.8		1.0	
	rpm	Vdc	rpm	Vdc	rpm	Vdc	rpm	Vdc	rpm	Vdc
2550	1091	4.9	1198	5.4	1298	5.8	1391	6.3	1478	6.7
2760	1164	5.2	1264	5.7	1359	6.1	1448	6.5	1532	6.9
2975	1238	5.6	1332	6.0	1422	6.4	1507	6.8	1588	7.2
3190	1312	5.9	1402	6.3	1487	6.7	1569	7.1	1646	7.4
3400	1388	6.3	1473	6.6	1554	7.0	1632	7.4	1706	7.7
3610	1464	6.6	1544	7.0	1622	7.3	1696	7.7	1768	8.0
3825	1541	7.0	1617	7.3	1691	7.7	1762	8.0	1831	8.3
4040	1618	7.3	1691	7.7	1761	8.0	1830	8.3	1896	8.6
4250	1696	7.7	1765	8.0	1832	8.3	1898	8.6	1962	8.9

CFM	AVAILABLE EXTERNAL STATIC PRESSURE (in. wg)									
	1.2		1.4		1.6		1.8		2.0	
	rpm	Vdc	rpm	Vdc	rpm	Vdc	rpm	Vdc	rpm	Vdc
2550	1559	7.0	1636	7.4	1709	7.7	1779	8.1	1846	8.4
2760	1611	7.3	1686	7.6	1758	8.0	1826	8.3	1892	8.6
2975	1665	7.5	1738	7.9	1808	8.2	1875	8.5	1939	8.8
3190	1721	7.8	1792	8.1	1860	8.4	1925	8.7	1988	9.0
3400	1778	8.1	1847	8.4	1913	8.7	1977	9.0	2039	9.3
3610	1837	8.3	1904	8.6	1969	8.9	2031	9.2	2091	9.5
3825	1898	8.6	1963	8.9	2026	9.2	2086	9.5	—	—
4040	1961	8.9	2023	9.2	2084	9.5	—	—	—	—
4250	2024	9.2	2085	9.5	2144	9.7	—	—	—	—

High Static 1091-2200 rpm

## 48FCFM12 — 10 TON VERTICAL SUPPLY (RPM - BHP)

CFM	AVAILABLE EXTERNAL STATIC PRESSURE (in. wg)									
	0.2		0.4		0.6		0.8		1.0	
	rpm	bhp	rpm	bhp	rpm	bhp	rpm	bhp	rpm	bhp
3000	1266	0.74	1360	0.92	1449	1.12	1534	1.32	1613	1.54
3250	1357	0.91	1444	1.09	1528	1.29	1608	1.51	1684	1.73
3500	1448	1.09	1530	1.28	1609	1.49	1685	1.72	1758	1.95
3750	1539	1.29	1617	1.49	1691	1.71	1764	1.94	1833	2.18
4000	1632	1.51	1705	1.72	1775	1.94	1844	2.18	1911	2.42
4250	1725	1.74	1794	1.96	1861	2.19	1926	2.43	1990	2.68
4500	1818	1.99	1884	2.22	1948	2.45	2010	2.69	2071	2.94
4750	1912	2.25	1974	2.47	2035	2.71	2095	2.96	2153	3.21
5000	2006	2.51	2066	2.74	2124	2.98	2181	3.23	—	—

CFM	AVAILABLE EXTERNAL STATIC PRESSURE (in. wg)									
	1.2		1.4		1.6		1.8		2.0	
	rpm	bhp	rpm	bhp	rpm	bhp	rpm	bhp	rpm	bhp
3000	1689	1.77	1762	2.01	1831	2.25	1897	2.50	1961	2.77
3250	1757	1.97	1827	2.21	1894	2.47	1959	2.73	2021	3.00
3500	1828	2.19	1895	2.44	1960	2.70	2023	2.97	2084	3.25
3750	1900	2.42	1965	2.68	2028	2.95	2089	3.22	2148	3.50
4000	1975	2.67	2038	2.94	2099	3.21	2158	3.49	—	—
4250	2052	2.94	2112	3.20	2171	3.48	—	—	—	—
4500	2130	3.20	2188	3.47	—	—	—	—	—	—
4750	—	—	—	—	—	—	—	—	—	—
5000	—	—	—	—	—	—	—	—	—	—

Std/Med Static 1266-2000 rpm, 2.4 Max bhp

High Static 1266-2200 rpm, 5.0 Max bhp

## 48FCFM12 – STANDARD/MEDIUM STATIC — 10 TON VERTICAL SUPPLY (RPM - VDC)

CFM	AVAILABLE EXTERNAL STATIC PRESSURE (in. wg)									
	0.2		0.4		0.6		0.8		1.0	
	rpm	Vdc	rpm	Vdc	rpm	Vdc	rpm	Vdc	rpm	Vdc
3000	1266	6.2	1360	6.7	1449	7.2	1534	7.6	1613	8.0
3250	1357	6.7	1444	7.1	1528	7.6	1608	8.0	1684	8.4
3500	1448	7.2	1530	7.6	1609	8.0	1685	8.4	1758	8.8
3750	1539	7.6	1617	8.0	1691	8.4	1764	8.8	1833	9.1
4000	1632	8.1	1705	8.5	1775	8.8	1844	9.2	—	—
4250	1725	8.6	1794	8.9	1861	9.3	—	—	—	—
4500	1818	9.1	1884	9.4	—	—	—	—	—	—
4750	1912	9.5	—	—	—	—	—	—	—	—
5000	—	—	—	—	—	—	—	—	—	—

CFM	AVAILABLE EXTERNAL STATIC PRESSURE (in. wg)									
	1.2		1.4		1.6		1.8		2.0	
	rpm	Vdc	rpm	Vdc	rpm	Vdc	rpm	Vdc	rpm	Vdc
3000	1689	8.4	1762	8.8	1831	9.1	—	—	—	—
3250	1757	8.8	1827	9.1	—	—	—	—	—	—
3500	1828	9.1	—	—	—	—	—	—	—	—
3750	—	—	—	—	—	—	—	—	—	—
4000	—	—	—	—	—	—	—	—	—	—
4250	—	—	—	—	—	—	—	—	—	—
4500	—	—	—	—	—	—	—	—	—	—
4750	—	—	—	—	—	—	—	—	—	—
5000	—	—	—	—	—	—	—	—	—	—

Std/Med Static 1266-2000 rpm

## 48FCFM12 – HIGH STATIC — 10 TON VERTICAL SUPPLY (RPM - VDC)

CFM	AVAILABLE EXTERNAL STATIC PRESSURE (in. wg)									
	0.2		0.4		0.6		0.8		1.0	
	rpm	Vdc	rpm	Vdc	rpm	Vdc	rpm	Vdc	rpm	Vdc
3000	1266	5.7	1360	6.1	1449	6.5	1534	6.9	1613	7.3
3250	1357	6.1	1444	6.5	1528	6.9	1608	7.3	1684	7.6
3500	1448	6.5	1530	6.9	1609	7.3	1685	7.6	1758	8.0
3750	1539	6.9	1617	7.3	1691	7.7	1764	8.0	1833	8.3
4000	1632	7.4	1705	7.7	1775	8.0	1844	8.4	1911	8.7
4250	1725	7.8	1794	8.1	1861	8.4	1926	8.7	1990	9.0
4500	1818	8.2	1884	8.5	1948	8.8	2010	9.1	2071	9.4
4750	1912	8.7	1974	9.0	2035	9.2	2095	9.5	2153	9.8
5000	2006	9.1	2066	9.4	2124	9.6	2181	9.9	—	—

CFM	AVAILABLE EXTERNAL STATIC PRESSURE (in. wg)									
	1.2		1.4		1.6		1.8		2.0	
	rpm	Vdc	rpm	Vdc	rpm	Vdc	rpm	Vdc	rpm	Vdc
3000	1689	7.6	1762	8.0	1831	8.3	1897	8.6	1961	8.9
3250	1757	8.0	1827	8.3	1894	8.6	1959	8.9	2021	9.2
3500	1828	8.3	1895	8.6	1960	8.9	2023	9.2	2084	9.5
3750	1900	8.6	1965	8.9	2028	9.2	2089	9.5	2148	9.8
4000	1975	9.0	2038	9.3	2099	9.5	2158	9.8	—	—
4250	2052	9.3	2112	9.6	2171	9.9	—	—	—	—
4500	2130	9.7	2188	9.9	—	—	—	—	—	—
4750	—	—	—	—	—	—	—	—	—	—
5000	—	—	—	—	—	—	—	—	—	—

High Static 1266-2200 rpm

## 48FCFM14 — 12.5 TON VERTICAL SUPPLY (RPM - BHP)

CFM	AVAILABLE EXTERNAL STATIC PRESSURE (in. wg)									
	0.2		0.4		0.6		0.8		1.0	
	rpm	bhp	rpm	bhp	rpm	bhp	rpm	bhp	rpm	bhp
3750	1320	1.21	1416	1.49	1503	1.79	1583	2.09	1657	2.39
4060	1414	1.48	1504	1.78	1587	2.09	1664	2.41	1736	2.74
4375	1509	1.79	1594	2.11	1673	2.44	1747	2.78	1817	3.13
4690	1604	2.14	1685	2.49	1761	2.84	1832	3.19	1899	3.56
5000	1700	2.54	1777	2.90	1849	3.26	1918	3.64	1983	4.03
5310	1797	2.97	1870	3.35	1939	3.73	2005	4.13	2068	4.53
5625	1894	3.44	1964	3.84	2030	4.24	2093	4.65	2154	5.06
5940	1992	3.95	2058	4.36	2121	4.77	—	—	—	—
6250	2090	4.50	2153	4.92	—	—	—	—	—	—

CFM	AVAILABLE EXTERNAL STATIC PRESSURE (in. wg)									
	1.2		1.4		1.6		1.8		2.0	
	rpm	bhp	rpm	bhp	rpm	bhp	rpm	bhp	rpm	bhp
3750	1727	2.71	1794	3.04	1857	3.37	1918	3.71	1976	4.06
4060	1804	3.08	1869	3.42	1930	3.77	1989	4.12	2046	4.49
4375	1883	3.48	1946	3.85	2005	4.21	2063	4.58	2119	4.97
4690	1963	3.93	2024	4.31	2082	4.69	2139	5.08	—	—
5000	2045	4.42	2104	4.81	—	—	—	—	—	—
5310	2128	4.93	—	—	—	—	—	—	—	—
5625	—	—	—	—	—	—	—	—	—	—
5940	—	—	—	—	—	—	—	—	—	—
6250	—	—	—	—	—	—	—	—	—	—

Std/Med Static 1320-2200 rpm, 3.0 Max bhp

High Static 1320-2200 rpm, 5.0 Max bhp

## 48FCFM14 - STANDARD/MEDIUM STATIC — 12.5 TON VERTICAL SUPPLY (RPM - VDC)

CFM	AVAILABLE EXTERNAL STATIC PRESSURE (in. wg)									
	0.2		0.4		0.6		0.8		1.0	
	rpm	Vdc	rpm	Vdc	rpm	Vdc	rpm	Vdc	rpm	Vdc
3750	1320	5.9	1416	6.4	1503	6.8	1583	7.2	1657	7.5
4060	1414	6.4	1504	6.8	1587	7.2	1664	7.5	1736	7.9
4375	1509	6.8	1594	7.2	1673	7.6	1747	7.9	—	—
4690	1604	7.2	1685	7.6	1761	8.0	—	—	—	—
5000	1700	7.7	1777	8.0	—	—	—	—	—	—
5310	1797	8.1	—	—	—	—	—	—	—	—
5625	—	—	—	—	—	—	—	—	—	—
5940	—	—	—	—	—	—	—	—	—	—
6250	—	—	—	—	—	—	—	—	—	—

CFM	AVAILABLE EXTERNAL STATIC PRESSURE (in. wg)									
	1.2		1.4		1.6		1.8		2.0	
	rpm	Vdc	rpm	Vdc	rpm	Vdc	rpm	Vdc	rpm	Vdc
3750	1727	7.8	—	—	—	—	—	—	—	—
4060	—	—	—	—	—	—	—	—	—	—
4375	—	—	—	—	—	—	—	—	—	—
4690	—	—	—	—	—	—	—	—	—	—
5000	—	—	—	—	—	—	—	—	—	—
5310	—	—	—	—	—	—	—	—	—	—
5625	—	—	—	—	—	—	—	—	—	—
5940	—	—	—	—	—	—	—	—	—	—
6250	—	—	—	—	—	—	—	—	—	—

Std/Med Static 1320-2200 rpm

## 48FCFM14 - HIGH STATIC — 12.5 TON VERTICAL SUPPLY (RPM - VDC)

CFM	AVAILABLE EXTERNAL STATIC PRESSURE (in. wg)									
	0.2		0.4		0.6		0.8		1.0	
	rpm	Vdc	rpm	Vdc	rpm	Vdc	rpm	Vdc	rpm	Vdc
3750	1320	5.9	1416	6.4	1503	6.8	1583	7.2	1657	7.5
4060	1414	6.4	1504	6.8	1587	7.2	1664	7.5	1736	7.9
4375	1509	6.8	1594	7.2	1673	7.6	1747	7.9	1817	8.2
4690	1604	7.2	1685	7.6	1761	8.0	1832	8.3	1899	8.6
5000	1700	7.7	1777	8.0	1849	8.4	1918	8.7	1983	9.0
5310	1797	8.1	1870	8.5	1939	8.8	2005	9.1	2068	9.4
5625	1894	8.6	1964	8.9	2030	9.2	2093	9.5	2154	9.8
5940	1992	9.0	2058	9.3	2121	9.6	—	—	—	—
6250	2090	9.5	2153	9.8	—	—	—	—	—	—

CFM	AVAILABLE EXTERNAL STATIC PRESSURE (in. wg)									
	1.2		1.4		1.6		1.8		2.0	
	rpm	Vdc	rpm	Vdc	rpm	Vdc	rpm	Vdc	rpm	Vdc
3750	1727	7.8	1794	8.1	1857	8.4	1918	8.7	1976	9.0
4060	1804	8.2	1869	8.5	1930	8.8	1989	9.0	2046	9.3
4375	1883	8.5	1946	8.8	2005	9.1	2063	9.4	2119	9.6
4690	1963	8.9	2024	9.2	2082	9.5	2139	9.7	—	—
5000	2045	9.3	2104	9.6	—	—	—	—	—	—
5310	2128	9.7	—	—	—	—	—	—	—	—
5625	—	—	—	—	—	—	—	—	—	—
5940	—	—	—	—	—	—	—	—	—	—
6250	—	—	—	—	—	—	—	—	—	—

High Static 1320-2200 rpm

## 48FCFM16 — 15 TON VERTICAL SUPPLY (RPM - BHP)

CFM	AVAILABLE EXTERNAL STATIC PRESSURE (in. wg)									
	0.2		0.4		0.6		0.8		1.0	
	rpm	bhp	rpm	bhp	rpm	bhp	rpm	bhp	rpm	bhp
4500	1251	1.02	1332	1.23	1412	1.47	1491	1.73	1569	2.02
4875	1343	1.26	1417	1.48	1491	1.72	1565	1.99	1637	2.28
5250	1435	1.52	1504	1.75	1573	2.00	1641	2.28	1709	2.57
5625	1528	1.81	1592	2.05	1657	2.31	1721	2.59	1785	2.89
6000	1621	2.13	1682	2.38	1742	2.64	1802	2.92	1862	3.23
6375	1715	2.47	1772	2.73	1829	3.00	1886	3.29	1942	3.59
6750	1810	2.86	1863	3.11	1917	3.39	1971	3.69	2024	3.99
7125	1905	3.29	1955	3.56	2006	3.84	2057	4.15	2108	4.46
7500	2000	3.82	2048	4.10	2096	4.40	2144	4.71	2193	5.04

CFM	AVAILABLE EXTERNAL STATIC PRESSURE (in. wg)									
	1.2		1.4		1.6		1.8		2.0	
	rpm	bhp	rpm	bhp	rpm	bhp	rpm	bhp	rpm	bhp
4500	1645	2.33	1719	2.65	1792	3.01	1862	3.37	1930	3.76
4875	1709	2.59	1779	2.93	1848	3.28	1915	3.65	1981	4.04
5250	1777	2.89	1843	3.22	1908	3.58	1973	3.95	2036	4.35
5625	1848	3.21	1911	3.55	1973	3.90	2034	4.28	2094	4.67
6000	1922	3.55	1981	3.88	2040	4.24	2098	4.61	2156	5.01
6375	1999	3.92	2055	4.26	2111	4.61	2166	4.98	—	—
6750	2078	4.32	2131	4.66	2184	5.02	—	—	—	—
7125	2158	4.79	—	—	—	—	—	—	—	—
7500	—	—	—	—	—	—	—	—	—	—

Std/Med Static 1251-2200 rpm, 3.0 Max bhp

High Static 1251-2200 rpm, 5.0 Max bhp

## 48FCFM16 – STANDARD/MEDIUM STATIC — 15 TON VERTICAL SUPPLY (RPM - VDC)

CFM	AVAILABLE EXTERNAL STATIC PRESSURE (in. wg)									
	0.2		0.4		0.6		0.8		1.0	
	rpm	Vdc	rpm	Vdc	rpm	Vdc	rpm	Vdc	rpm	Vdc
4500	1251	5.6	1332	6.0	1412	6.4	1491	6.7	1569	7.1
4875	1343	6.0	1417	6.4	1491	6.7	1565	7.1	1637	7.4
5250	1435	6.5	1504	6.8	1573	7.1	1641	7.4	1709	7.7
5625	1528	6.9	1592	7.2	1657	7.5	1721	7.8	1785	8.1
6000	1621	7.3	1682	7.6	1742	7.9	1802	8.2	—	—
6375	1715	7.8	1772	8.0	—	—	—	—	—	—
6750	1810	8.2	—	—	—	—	—	—	—	—
7125	—	—	—	—	—	—	—	—	—	—
7500	—	—	—	—	—	—	—	—	—	—

CFM	AVAILABLE EXTERNAL STATIC PRESSURE (in. wg)									
	1.2		1.4		1.6		1.8		2.0	
	rpm	Vdc	rpm	Vdc	rpm	Vdc	rpm	Vdc	rpm	Vdc
4500	1645	7.4	1719	7.8	—	—	—	—	—	—
4875	1709	7.7	1779	8.1	—	—	—	—	—	—
5250	1777	8.0	—	—	—	—	—	—	—	—
5625	—	—	—	—	—	—	—	—	—	—
6000	—	—	—	—	—	—	—	—	—	—
6375	—	—	—	—	—	—	—	—	—	—
6750	—	—	—	—	—	—	—	—	—	—
7125	—	—	—	—	—	—	—	—	—	—
7500	—	—	—	—	—	—	—	—	—	—

Std/Med Static 1251-2200 rpm

## 48FCFM16 – HIGH STATIC — 15 TON VERTICAL SUPPLY (RPM - VDC)

CFM	AVAILABLE EXTERNAL STATIC PRESSURE (in. wg)									
	0.2		0.4		0.6		0.8		1.0	
	rpm	Vdc	rpm	Vdc	rpm	Vdc	rpm	Vdc	rpm	Vdc
4500	1251	5.6	1332	6.0	1412	6.4	1491	6.7	1569	7.1
4875	1343	6.0	1417	6.4	1491	6.7	1565	7.1	1637	7.4
5250	1435	6.5	1504	6.8	1573	7.1	1641	7.4	1709	7.7
5625	1528	6.9	1592	7.2	1657	7.5	1721	7.8	1785	8.1
6000	1621	7.3	1682	7.6	1742	7.9	1802	8.2	1862	8.4
6375	1715	7.8	1772	8.0	1829	8.3	1886	8.6	1942	8.8
6750	1810	8.2	1863	8.4	1917	8.7	1971	8.9	2024	9.2
7125	1905	8.6	1955	8.9	2006	9.1	2057	9.3	2108	9.6
7500	2000	9.1	2048	9.3	2096	9.5	2144	9.7	2193	10.0

CFM	AVAILABLE EXTERNAL STATIC PRESSURE (in. wg)									
	1.2		1.4		1.6		1.8		2.0	
	rpm	Vdc	rpm	Vdc	rpm	Vdc	rpm	Vdc	rpm	Vdc
4500	1645	7.4	1719	7.8	1792	8.1	1862	8.4	1930	8.8
4875	1709	7.7	1779	8.1	1848	8.4	1915	8.7	1981	9.0
5250	1777	8.0	1843	8.4	1908	8.7	1973	9.0	2036	9.2
5625	1848	8.4	1911	8.7	1973	9.0	2034	9.2	2094	9.5
6000	1922	8.7	1981	9.0	2040	9.3	2098	9.5	2156	9.8
6375	1999	9.1	2055	9.3	2111	9.6	2166	9.8	—	—
6750	2078	9.4	2131	9.7	2184	9.9	—	—	—	—
7125	2158	9.8	—	—	—	—	—	—	—	—
7500	—	—	—	—	—	—	—	—	—	—

High Static 1251-2200 rpm

## 48FCFM08 — 7.5 TON HORIZONTAL SUPPLY (RPM - BHP)

CFM	AVAILABLE EXTERNAL STATIC PRESSURE (in. wg)									
	0.2		0.4		0.6		0.8		1.0	
	rpm	bhp	rpm	bhp	rpm	bhp	rpm	bhp	rpm	bhp
2250	987	0.36	1114	0.52	1227	0.70	1331	0.89	1428	1.10
2440	1047	0.43	1168	0.60	1277	0.78	1377	0.98	1471	1.20
2625	1109	0.51	1223	0.68	1328	0.87	1424	1.08	1515	1.30
2810	1171	0.60	1280	0.78	1380	0.97	1474	1.19	1561	1.41
3000	1234	0.69	1338	0.88	1434	1.08	1524	1.30	1609	1.53
3190	1298	0.79	1397	0.99	1490	1.20	1577	1.42	1659	1.65
3375	1363	0.90	1458	1.10	1546	1.32	1630	1.54	1710	1.78
3560	1428	1.02	1519	1.22	1604	1.44	1685	1.67	1762	1.91
3750	1494	1.14	1580	1.35	1663	1.57	1741	1.80	1816	2.05

CFM	AVAILABLE EXTERNAL STATIC PRESSURE (in. wg)									
	1.2		1.4		1.6		1.8		2.0	
	rpm	bhp	rpm	bhp	rpm	bhp	rpm	bhp	rpm	bhp
2250	1518	1.32	1602	1.55	1682	1.79	1757	2.04	1830	2.31
2440	1558	1.42	1641	1.66	1719	1.91	1794	2.17	1865	2.44
2625	1600	1.53	1681	1.77	1758	2.03	1831	2.29	1902	2.57
2810	1644	1.65	1723	1.90	1798	2.15	1871	2.43	1940	2.71
3000	1690	1.77	1767	2.02	1841	2.29	1911	2.56	1979	2.84
3190	1737	1.90	1813	2.16	1884	2.42	1954	2.70	2020	2.98
3375	1786	2.03	1859	2.29	1930	2.56	1997	2.84	2063	3.13
3560	1836	2.16	1908	2.43	1976	2.70	2042	2.98	—	—
3750	1888	2.30	1957	2.56	2024	2.83	2089	3.11	—	—

Std/Med Static 987-2000 rpm, 2.4 Max bhp

High Static 987-2200 rpm, 3.0 Max bhp

## 48FCFM08 - STANDARD/MEDIUM STATIC — 7.5 TON HORIZONTAL SUPPLY (RPM - VDC)

CFM	AVAILABLE EXTERNAL STATIC PRESSURE (in. wg)									
	0.2		0.4		0.6		0.8		1.0	
	rpm	Vdc	rpm	Vdc	rpm	Vdc	rpm	Vdc	rpm	Vdc
2250	987	4.8	1114	5.4	1227	6.0	1331	6.6	1428	7.1
2440	1047	5.1	1168	5.7	1277	6.3	1377	6.8	1471	7.3
2625	1109	5.4	1223	6.0	1328	6.5	1424	7.0	1515	7.5
2810	1171	5.7	1280	6.3	1380	6.8	1474	7.3	1561	7.7
3000	1234	6.1	1338	6.6	1434	7.1	1524	7.6	1609	8.0
3190	1298	6.4	1397	6.9	1490	7.4	1577	7.8	1659	8.2
3375	1363	6.7	1458	7.2	1546	7.7	1630	8.1	1710	8.5
3560	1428	7.1	1519	7.5	1604	8.0	1685	8.4	1762	8.8
3750	1494	7.4	1580	7.8	1663	8.3	1741	8.7	1816	9.1

CFM	AVAILABLE EXTERNAL STATIC PRESSURE (in. wg)									
	1.2		1.4		1.6		1.8		2.0	
	rpm	Vdc	rpm	Vdc	rpm	Vdc	rpm	Vdc	rpm	Vdc
2250	1518	7.5	1602	8.0	1682	8.4	1757	8.8	1830	9.1
2440	1558	7.7	1641	8.2	1719	8.6	1794	8.9	—	—
2625	1600	7.9	1681	8.4	1758	8.8	1831	9.1	—	—
2810	1644	8.2	1723	8.6	1798	9.0	—	—	—	—
3000	1690	8.4	1767	8.8	1841	9.2	—	—	—	—
3190	1737	8.6	1813	9.0	—	—	—	—	—	—
3375	1786	8.9	1859	9.3	—	—	—	—	—	—
3560	1836	9.2	—	—	—	—	—	—	—	—
3750	1888	9.4	—	—	—	—	—	—	—	—

Std/Med Static 987-2000 rpm



## 48FCFM08 – HIGH STATIC — 7.5 TON HORIZONTAL SUPPLY (RPM - VDC)

CFM	AVAILABLE EXTERNAL STATIC PRESSURE (in. wg)									
	0.2		0.4		0.6		0.8		1.0	
	rpm	Vdc	rpm	Vdc	rpm	Vdc	rpm	Vdc	rpm	Vdc
2250	987	4.4	1114	5.0	1227	5.5	1331	6.0	1428	6.4
2440	1047	4.7	1168	5.2	1277	5.7	1377	6.2	1471	6.6
2625	1109	5.0	1223	5.5	1328	6.0	1424	6.4	1515	6.8
2810	1171	5.3	1280	5.8	1380	6.2	1474	6.6	1561	7.1
3000	1234	5.5	1338	6.0	1434	6.5	1524	6.9	1609	7.3
3190	1298	5.8	1397	6.3	1490	6.7	1577	7.1	1659	7.5
3375	1363	6.1	1458	6.6	1546	7.0	1630	7.4	1710	7.7
3560	1428	6.4	1519	6.9	1604	7.2	1685	7.6	1762	8.0
3750	1494	6.7	1580	7.1	1663	7.5	1741	7.9	1816	8.2

CFM	AVAILABLE EXTERNAL STATIC PRESSURE (in. wg)									
	1.2		1.4		1.6		1.8		2.0	
	rpm	Vdc	rpm	Vdc	rpm	Vdc	rpm	Vdc	rpm	Vdc
2250	1518	6.9	1602	7.2	1682	7.6	1757	8.0	1830	8.3
2440	1558	7.0	1641	7.4	1719	7.8	1794	8.1	1865	8.5
2625	1600	7.2	1681	7.6	1758	8.0	1831	8.3	1902	8.6
2810	1644	7.4	1723	7.8	1798	8.1	1871	8.5	1940	8.8
3000	1690	7.6	1767	8.0	1841	8.3	1911	8.7	1979	9.0
3190	1737	7.9	1813	8.2	1884	8.5	1954	8.9	2020	9.2
3375	1786	8.1	1859	8.4	1930	8.8	1997	9.1	2063	9.4
3560	1836	8.3	1908	8.7	1976	9.0	2042	9.3	—	—
3750	1888	8.6	1957	8.9	2024	9.2	2089	9.5	—	—

High Static 987-2200 rpm

## 48FCFM09 — 8.5 TON HORIZONTAL SUPPLY (RPM - BHP)

CFM	AVAILABLE EXTERNAL STATIC PRESSURE (in. wg)									
	0.2		0.4		0.6		0.8		1.0	
	rpm	bhp	rpm	bhp	rpm	bhp	rpm	bhp	rpm	bhp
2550	1026	0.40	1140	0.55	1248	0.72	1349	0.91	1442	1.11
2760	1092	0.48	1199	0.63	1301	0.80	1398	1.00	1488	1.20
2975	1160	0.56	1261	0.72	1357	0.90	1449	1.10	1536	1.31
3190	1229	0.66	1323	0.83	1414	1.01	1502	1.21	1586	1.42
3400	1298	0.77	1387	0.94	1473	1.12	1557	1.33	1638	1.55
3610	1368	0.88	1452	1.06	1535	1.25	1614	1.45	1692	1.67
3825	1439	1.01	1519	1.19	1597	1.38	1673	1.58	1747	1.80
4040	1511	1.14	1586	1.32	1660	1.51	1733	1.72	1804	1.94
4250	1582	1.27	1654	1.45	1725	1.64	1795	1.85	1863	2.07

CFM	AVAILABLE EXTERNAL STATIC PRESSURE (in. wg)									
	1.2		1.4		1.6		1.8		2.0	
	rpm	bhp	rpm	bhp	rpm	bhp	rpm	bhp	rpm	bhp
2550	1529	1.32	1611	1.54	1688	1.77	1761	2.01	1830	2.26
2760	1573	1.42	1654	1.65	1730	1.89	1802	2.14	1870	2.39
2975	1619	1.53	1698	1.77	1773	2.01	1844	2.27	1911	2.52
3190	1667	1.65	1743	1.89	1817	2.14	1887	2.40	1954	2.66
3400	1716	1.78	1790	2.02	1862	2.27	1931	2.53	1997	2.80
3610	1767	1.91	1839	2.15	1909	2.40	1977	2.67	2041	2.94
3825	1820	2.04	1890	2.28	1958	2.54	2024	2.80	2087	3.07
4040	1874	2.17	1942	2.42	2008	2.67	2072	2.93	—	—
4250	1930	2.30	1996	2.55	2060	2.80	2122	3.06	—	—

Std/Med Static 1026-2000 rpm, 2.4 Max bhp

High Static 1026-2200 rpm, 3.0 Max bhp

## 48FCFM09 - STANDARD/MEDIUM STATIC — 8.5 TON HORIZONTAL SUPPLY (RPM - VDC)

CFM	AVAILABLE EXTERNAL STATIC PRESSURE (in. wg)									
	0.2		0.4		0.6		0.8		1.0	
	rpm	Vdc	rpm	Vdc	rpm	Vdc	rpm	Vdc	rpm	Vdc
2250	1026	5.0	1140	5.6	1248	6.1	1349	6.7	1442	7.1
2440	1092	5.3	1199	5.9	1301	6.4	1398	6.9	1488	7.4
2625	1160	5.7	1261	6.2	1357	6.7	1449	7.2	1536	7.6
2810	1229	6.0	1323	6.5	1414	7.0	1502	7.4	1586	7.9
3000	1298	6.4	1387	6.8	1473	7.3	1557	7.7	1638	8.1
3190	1368	6.7	1452	7.2	1535	7.6	1614	8.0	1692	8.4
3375	1439	7.1	1519	7.5	1597	7.9	1673	8.3	1747	8.7
3560	1511	7.5	1586	7.9	1660	8.3	1733	8.6	1804	9.0
3750	1582	7.9	1654	8.2	1725	8.6	1795	8.9	1863	9.3

CFM	AVAILABLE EXTERNAL STATIC PRESSURE (in. wg)									
	1.2		1.4		1.6		1.8		2.0	
	rpm	Vdc	rpm	Vdc	rpm	Vdc	rpm	Vdc	rpm	Vdc
2550	1529	7.6	1611	8.0	1688	8.4	1761	8.8	1830	9.1
2760	1573	7.8	1654	8.2	1730	8.6	1802	9.0	1870	9.3
2975	1619	8.0	1698	8.4	1773	8.8	1844	9.2	—	—
3190	1667	8.3	1743	8.7	1817	9.1	1887	9.4	—	—
3400	1716	8.5	1790	8.9	1862	9.3	—	—	—	—
3610	1767	8.8	1839	9.2	1909	9.5	—	—	—	—
3825	1820	9.1	1890	9.4	—	—	—	—	—	—
4040	1874	9.4	—	—	—	—	—	—	—	—
4250	1930	9.6	—	—	—	—	—	—	—	—

Std/Med Static 1026-2000 rpm

## 48FCFM09 – HIGH STATIC — 8.5 TON HORIZONTAL SUPPLY (RPM - VDC)

CFM	AVAILABLE EXTERNAL STATIC PRESSURE (in. wg)									
	0.2		0.4		0.6		0.8		1.0	
	rpm	Vdc	rpm	Vdc	rpm	Vdc	rpm	Vdc	rpm	Vdc
2550	1026	4.6	1140	5.1	1248	5.6	1349	6.1	1442	6.5
2760	1092	4.9	1199	5.4	1301	5.9	1398	6.3	1488	6.7
2975	1160	5.2	1261	5.7	1357	6.1	1449	6.5	1536	6.9
3190	1229	5.5	1323	6.0	1414	6.4	1502	6.8	1586	7.2
3400	1298	5.8	1387	6.2	1473	6.6	1557	7.0	1638	7.4
3610	1368	6.2	1452	6.5	1535	6.9	1614	7.3	1692	7.7
3825	1439	6.5	1519	6.9	1597	7.2	1673	7.6	1747	7.9
4040	1511	6.8	1586	7.2	1660	7.5	1733	7.8	1804	8.2
4250	1582	7.1	1654	7.5	1725	7.8	1795	8.1	1863	8.4

CFM	AVAILABLE EXTERNAL STATIC PRESSURE (in. wg)									
	1.2		1.4		1.6		1.8		2.0	
	rpm	Vdc	rpm	Vdc	rpm	Vdc	rpm	Vdc	rpm	Vdc
2550	1529	6.9	1611	7.3	1688	7.6	1761	8.0	1830	8.3
2760	1573	7.1	1654	7.5	1730	7.8	1802	8.2	1870	8.5
2975	1619	7.3	1698	7.7	1773	8.0	1844	8.4	1911	8.7
3190	1667	7.5	1743	7.9	1817	8.2	1887	8.6	1954	8.9
3400	1716	7.8	1790	8.1	1862	8.4	1931	8.8	1997	9.1
3610	1767	8.0	1839	8.3	1909	8.7	1977	9.0	2041	9.3
3825	1820	8.2	1890	8.6	1958	8.9	2024	9.2	2087	9.5
4040	1874	8.5	1942	8.8	2008	9.1	2072	9.4	—	—
4250	1930	8.8	1996	9.1	2060	9.4	2122	9.6	—	—

High Static 1026-2200 rpm

## 48FCFM12 — 10 TON HORIZONTAL SUPPLY (RPM - BHP)

CFM	AVAILABLE EXTERNAL STATIC PRESSURE (in. wg)									
	0.2		0.4		0.6		0.8		1.0	
	rpm	bhp	rpm	bhp	rpm	bhp	rpm	bhp	rpm	bhp
3000	1188	0.62	1288	0.78	1384	0.97	1475	1.18	1562	1.40
3250	1271	0.75	1364	0.92	1454	1.12	1540	1.33	1623	1.55
3500	1355	0.89	1441	1.07	1526	1.27	1608	1.49	1687	1.72
3750	1439	1.05	1521	1.24	1600	1.45	1678	1.67	1753	1.90
4000	1525	1.23	1601	1.42	1676	1.63	1750	1.86	1822	2.10
4250	1611	1.42	1683	1.62	1754	1.83	1824	2.06	1892	2.30
4500	1697	1.62	1765	1.82	1833	2.04	1899	2.27	1965	2.51
4750	1784	1.83	1849	2.03	1913	2.25	1976	2.48	2038	2.72
5000	1872	2.04	1933	2.25	1994	2.47	2054	2.70	2114	2.94

CFM	AVAILABLE EXTERNAL STATIC PRESSURE (in. wg)									
	1.2		1.4		1.6		1.8		2.0	
	rpm	bhp	rpm	bhp	rpm	bhp	rpm	bhp	rpm	bhp
3000	1644	1.63	1722	1.87	1796	2.13	1866	2.38	1933	2.65
3250	1702	1.79	1778	2.04	1850	2.30	1919	2.57	1985	2.84
3500	1763	1.96	1836	2.22	1906	2.48	1974	2.76	2039	3.04
3750	1826	2.15	1897	2.41	1965	2.68	2031	2.96	2094	3.24
4000	1892	2.35	1960	2.61	2026	2.89	2090	3.17	2152	3.46
4250	1959	2.56	2025	2.82	2088	3.09	2150	3.38	—	—
4500	2029	2.77	2092	3.03	2153	3.31	—	—	—	—
4750	2100	2.98	2160	3.24	—	—	—	—	—	—
5000	2173	3.19	—	—	—	—	—	—	—	—

Std/Med Static 1188-2000 rpm, 2.4 Max bhp

High Static 1188-2200 rpm, 5.0 Max bhp

## 48FCFM12 – STANDARD/MEDIUM STATIC — 10 TON HORIZONTAL SUPPLY (RPM - VDC)

CFM	AVAILABLE EXTERNAL STATIC PRESSURE (in. wg)									
	0.2		0.4		0.6		0.8		1.0	
	rpm	Vdc	rpm	Vdc	rpm	Vdc	rpm	Vdc	rpm	Vdc
3000	1188	5.8	1288	6.3	1384	6.8	1475	7.3	1562	7.7
3250	1271	6.3	1364	6.7	1454	7.2	1540	7.6	1623	8.1
3500	1355	6.7	1441	7.1	1526	7.6	1608	8.0	1687	8.4
3750	1439	7.1	1521	7.5	1600	7.9	1678	8.3	1753	8.7
4000	1525	7.6	1601	7.9	1676	8.3	1750	8.7	1822	9.1
4250	1611	8.0	1683	8.4	1754	8.7	1824	9.1	1892	9.4
4500	1697	8.4	1765	8.8	1833	9.1	1899	9.5	—	—
4750	1784	8.9	1849	9.2	1913	9.6	—	—	—	—
5000	1872	9.3	1933	9.7	—	—	—	—	—	—

CFM	AVAILABLE EXTERNAL STATIC PRESSURE (in. wg)									
	1.2		1.4		1.6		1.8		2.0	
	rpm	Vdc	rpm	Vdc	rpm	Vdc	rpm	Vdc	rpm	Vdc
3000	1644	8.2	1722	8.6	1796	9.0	1866	9.3	—	—
3250	1702	8.5	1778	8.9	1850	9.2	—	—	—	—
3500	1763	8.8	1836	9.2	1906	9.5	—	—	—	—
3750	1826	9.1	1897	9.5	—	—	—	—	—	—
4000	1892	9.4	—	—	—	—	—	—	—	—
4250	—	—	—	—	—	—	—	—	—	—
4500	—	—	—	—	—	—	—	—	—	—
4750	—	—	—	—	—	—	—	—	—	—
5000	—	—	—	—	—	—	—	—	—	—

Std/Med Static 1188-2000 rpm

## 48FCFM12 – HIGH STATIC – 10 TON HORIZONTAL SUPPLY (RPM - VDC)

CFM	AVAILABLE EXTERNAL STATIC PRESSURE (in. wg)									
	0.2		0.4		0.6		0.8		1.0	
	rpm	Vdc	rpm	Vdc	rpm	Vdc	rpm	Vdc	rpm	Vdc
3000	1188	5.3	1288	5.8	1384	6.2	1475	6.7	1562	7.1
3250	1271	5.7	1364	6.1	1454	6.6	1540	7.0	1623	7.3
3500	1355	6.1	1441	6.5	1526	6.9	1608	7.3	1687	7.6
3750	1439	6.5	1521	6.9	1600	7.2	1678	7.6	1753	7.9
4000	1525	6.9	1601	7.2	1676	7.6	1750	7.9	1822	8.3
4250	1611	7.3	1683	7.6	1754	7.9	1824	8.3	1892	8.6
4500	1697	7.7	1765	8.0	1833	8.3	1899	8.6	1965	8.9
4750	1784	8.1	1849	8.4	1913	8.7	1976	9.0	2038	9.3
5000	1872	8.5	1933	8.8	1994	9.0	2054	9.3	2114	9.6

CFM	AVAILABLE EXTERNAL STATIC PRESSURE (in. wg)									
	1.2		1.4		1.6		1.8		2.0	
	rpm	Vdc	rpm	Vdc	rpm	Vdc	rpm	Vdc	rpm	Vdc
3000	1644	7.4	1722	7.8	1796	8.1	1866	8.5	1933	8.8
3250	1702	7.7	1778	8.1	1850	8.4	1919	8.7	1985	9.0
3500	1763	8.0	1836	8.3	1906	8.6	1974	9.0	2039	9.3
3750	1826	8.3	1897	8.6	1965	8.9	2031	9.2	2094	9.5
4000	1892	8.6	1960	8.9	2026	9.2	2090	9.5	2152	9.8
4250	1959	8.9	2025	9.2	2088	9.5	2150	9.8	—	—
4500	2029	9.2	2092	9.5	2153	9.8	—	—	—	—
4750	2100	9.5	2160	9.8	—	—	—	—	—	—
5000	2173	9.9	—	—	—	—	—	—	—	—

High Static 1188-2200 rpm

## 48FCFM14 — 12.5 TON HORIZONTAL SUPPLY (RPM - BHP)

CFM	AVAILABLE EXTERNAL STATIC PRESSURE (in. wg)									
	0.2		0.4		0.6		0.8		1.0	
	rpm	bhp	rpm	bhp	rpm	bhp	rpm	bhp	rpm	bhp
3750	1198	0.90	1298	1.15	1393	1.42	1483	1.72	1566	2.02
4060	1282	1.10	1374	1.36	1464	1.64	1550	1.95	1631	2.27
4375	1367	1.33	1453	1.60	1537	1.90	1619	2.21	1697	2.55
4690	1453	1.59	1533	1.87	1613	2.18	1690	2.51	1765	2.86
5000	1540	1.89	1615	2.17	1690	2.49	1763	2.83	1835	3.19
5310	1628	2.21	1697	2.50	1768	2.83	1838	3.18	1906	3.55
5625	1715	2.56	1781	2.86	1847	3.19	1914	3.55	1979	3.93
5940	1804	2.94	1866	3.25	1929	3.59	1992	3.95	2054	4.33
6250	1892	3.34	1951	3.66	2011	4.01	2071	4.37	2131	4.77

CFM	AVAILABLE EXTERNAL STATIC PRESSURE (in. wg)									
	1.2		1.4		1.6		1.8		2.0	
	rpm	bhp	rpm	bhp	rpm	bhp	rpm	bhp	rpm	bhp
3750	1644	2.34	1718	2.67	1787	3.00	1854	3.35	1917	3.70
4060	1707	2.61	1778	2.95	1847	3.30	1912	3.66	1974	4.03
4375	1771	2.90	1841	3.26	1908	3.63	1971	4.00	2033	4.39
4690	1836	3.22	1905	3.59	1970	3.97	2033	4.37	2093	4.76
5000	1904	3.56	1970	3.95	2034	4.34	2095	4.75	2154	5.16
5310	1973	3.93	2037	4.33	2099	4.74	2159	5.15	—	—
5625	2043	4.32	2106	4.73	2166	5.15	—	—	—	—
5940	2116	4.74	2176	5.15	—	—	—	—	—	—
6250	2189	5.17	—	—	—	—	—	—	—	—

Std/Med Static 1198-2200 rpm, 3.0 Max bhp

High Static 1198-2200 rpm, 5.0 Max bhp

## 48FCFM14 – STANDARD/MEDIUM STATIC — 12.5 TON HORIZONTAL SUPPLY (RPM - VDC)

CFM	AVAILABLE EXTERNAL STATIC PRESSURE (in. wg)									
	0.2		0.4		0.6		0.8		1.0	
	rpm	Vdc	rpm	Vdc	rpm	Vdc	rpm	Vdc	rpm	Vdc
3750	1198	5.4	1298	5.8	1393	6.3	1483	6.7	1566	7.1
4060	1282	5.8	1374	6.2	1464	6.6	1550	7.0	1631	7.4
4375	1367	6.2	1453	6.6	1537	6.9	1619	7.3	1697	7.7
4690	1453	6.6	1533	6.9	1613	7.3	1690	7.6	1765	8.0
5000	1540	7.0	1615	7.3	1690	7.6	1763	8.0	—	—
5310	1628	7.4	1697	7.7	1768	8.0	—	—	—	—
5625	1715	7.8	1781	8.1	—	—	—	—	—	—
5940	1804	8.2	—	—	—	—	—	—	—	—
6250	—	—	—	—	—	—	—	—	—	—

CFM	AVAILABLE EXTERNAL STATIC PRESSURE (in. wg)									
	1.2		1.4		1.6		1.8		2.0	
	rpm	Vdc	rpm	Vdc	rpm	Vdc	rpm	Vdc	rpm	Vdc
3750	1644	7.4	1718	7.8	1787	8.1	—	—	—	—
4060	1707	7.7	1778	8.1	—	—	—	—	—	—
4375	1771	8.0	—	—	—	—	—	—	—	—
4690	—	—	—	—	—	—	—	—	—	—
5000	—	—	—	—	—	—	—	—	—	—
5310	—	—	—	—	—	—	—	—	—	—
5625	—	—	—	—	—	—	—	—	—	—
5940	—	—	—	—	—	—	—	—	—	—
6250	—	—	—	—	—	—	—	—	—	—

Std/Med Static 1198-2200 rpm

## 48FCFM14 – HIGH STATIC — 12.5 TON HORIZONTAL SUPPLY (RPM - VDC)

CFM	AVAILABLE EXTERNAL STATIC PRESSURE (in. wg)									
	0.2		0.4		0.6		0.8		1.0	
	rpm	Vdc	rpm	Vdc	rpm	Vdc	rpm	Vdc	rpm	Vdc
3750	1198	5.4	1298	5.8	1393	6.3	1483	6.7	1566	7.1
4060	1282	5.8	1374	6.2	1464	6.6	1550	7.0	1631	7.4
4375	1367	6.2	1453	6.6	1537	6.9	1619	7.3	1697	7.7
4690	1453	6.6	1533	6.9	1613	7.3	1690	7.6	1765	8.0
5000	1540	7.0	1615	7.3	1690	7.6	1763	8.0	1835	8.3
5310	1628	7.4	1697	7.7	1768	8.0	1838	8.3	1906	8.6
5625	1715	7.8	1781	8.1	1847	8.4	1914	8.7	1979	9.0
5940	1804	8.2	1866	8.5	1929	8.7	1992	9.0	2054	9.3
6250	1892	8.6	1951	8.9	2011	9.1	2071	9.4	2131	9.7

CFM	AVAILABLE EXTERNAL STATIC PRESSURE (in. wg)									
	1.2		1.4		1.6		1.8		2.0	
	rpm	Vdc	rpm	Vdc	rpm	Vdc	rpm	Vdc	rpm	Vdc
3750	1644	7.4	1718	7.8	1787	8.1	1854	8.4	1917	8.7
4060	1707	7.7	1778	8.1	1847	8.4	1912	8.7	1974	9.0
4375	1771	8.0	1841	8.3	1908	8.7	1971	8.9	2033	9.2
4690	1836	8.3	1905	8.6	1970	8.9	2033	9.2	2093	9.5
5000	1904	8.6	1970	8.9	2034	9.2	2095	9.5	2154	9.8
5310	1973	9.0	2037	9.2	2099	9.5	2159	9.8	—	—
5625	2043	9.3	2106	9.6	2166	9.8	—	—	—	—
5940	2116	9.6	2176	9.9	—	—	—	—	—	—
6250	2189	9.9	—	—	—	—	—	—	—	—

High Static 1198-2200 rpm

## 48FCFM16 — 15 TON HORIZONTAL SUPPLY (RPM - BHP)

CFM	AVAILABLE EXTERNAL STATIC PRESSURE (in. wg)									
	0.2		0.4		0.6		0.8		1.0	
	rpm	bhp	rpm	bhp	rpm	bhp	rpm	bhp	rpm	bhp
4500	1248	1.02	1328	1.22	1408	1.46	1487	1.72	1566	2.01
4875	1339	1.25	1413	1.47	1487	1.71	1561	1.98	1634	2.27
5250	1431	1.51	1500	1.74	1568	1.98	1637	2.26	1705	2.55
5625	1524	1.80	1588	2.03	1652	2.29	1716	2.57	1780	2.87
6000	1617	2.11	1677	2.36	1737	2.62	1797	2.90	1857	3.20
6375	1711	2.46	1767	2.71	1824	2.98	1881	3.26	1937	3.56
6750	1805	2.83	1858	3.09	1912	3.37	1965	3.65	2019	3.96
7125	1899	3.26	1950	3.53	2001	3.82	2051	4.11	2102	4.42
7500	1994	3.79	2042	4.07	2090	4.36	2139	4.68	2187	5.00

CFM	AVAILABLE EXTERNAL STATIC PRESSURE (in. wg)									
	1.2		1.4		1.6		1.8		2.0	
	rpm	bhp	rpm	bhp	rpm	bhp	rpm	bhp	rpm	bhp
4500	1642	2.31	1717	2.64	1790	3.00	1861	3.37	1929	3.75
4875	1705	2.58	1776	2.91	1845	3.26	1913	3.64	1979	4.03
5250	1773	2.87	1839	3.20	1905	3.56	1970	3.94	2033	4.33
5625	1843	3.18	1906	3.52	1968	3.87	2030	4.25	2090	4.64
6000	1917	3.52	1976	3.86	2035	4.21	2094	4.59	2151	4.97
6375	1993	3.88	2050	4.22	2105	4.57	2161	4.95	—	—
6750	2072	4.28	2125	4.62	2178	4.98	—	—	—	—
7125	2153	4.75	—	—	—	—	—	—	—	—
7500	—	—	—	—	—	—	—	—	—	—

Std/Med Static 1248-2200 rpm, 3.0 Max bhp

High Static 1248-2200 rpm, 5.0 Max bhp

## 48FCFM16 – STANDARD/MEDIUM STATIC — 15 TON HORIZONTAL SUPPLY (RPM - VDC)

CFM	AVAILABLE EXTERNAL STATIC PRESSURE (in. wg)									
	0.2		0.4		0.6		0.8		1.0	
	rpm	Vdc	rpm	Vdc	rpm	Vdc	rpm	Vdc	rpm	Vdc
4500	1248	5.6	1328	6.0	1408	6.3	1487	6.7	1566	7.1
4875	1339	6.0	1413	6.4	1487	6.7	1561	7.1	1634	7.4
5250	1431	6.5	1500	6.8	1568	7.1	1637	7.4	1705	7.7
5625	1524	6.9	1588	7.2	1652	7.5	1716	7.8	1780	8.1
6000	1617	7.3	1677	7.6	1737	7.9	1797	8.1	—	—
6375	1711	7.7	1767	8.0	1824	8.3	—	—	—	—
6750	1805	8.2	—	—	—	—	—	—	—	—
7125	—	—	—	—	—	—	—	—	—	—
7500	—	—	—	—	—	—	—	—	—	—

CFM	AVAILABLE EXTERNAL STATIC PRESSURE (in. wg)									
	1.2		1.4		1.6		1.8		2.0	
	rpm	Vdc	rpm	Vdc	rpm	Vdc	rpm	Vdc	rpm	Vdc
4500	1642	7.4	1717	7.8	—	—	—	—	—	—
4875	1705	7.7	1776	8.0	—	—	—	—	—	—
5250	1773	8.0	—	—	—	—	—	—	—	—
5625	—	—	—	—	—	—	—	—	—	—
6000	—	—	—	—	—	—	—	—	—	—
6375	—	—	—	—	—	—	—	—	—	—
6750	—	—	—	—	—	—	—	—	—	—
7125	—	—	—	—	—	—	—	—	—	—
7500	—	—	—	—	—	—	—	—	—	—

Std/Med Static 1248-2200 rpm



## 48FCFM16 – HIGH STATIC – 15 TON HORIZONTAL SUPPLY (RPM - VDC)

CFM	AVAILABLE EXTERNAL STATIC PRESSURE (in. wg)									
	0.2		0.4		0.6		0.8		1.0	
	rpm	Vdc	rpm	Vdc	rpm	Vdc	rpm	Vdc	rpm	Vdc
4500	1248	5.6	1328	6.0	1408	6.3	1487	6.7	1566	7.1
4875	1339	6.0	1413	6.4	1487	6.7	1561	7.1	1634	7.4
5250	1431	6.5	1500	6.8	1568	7.1	1637	7.4	1705	7.7
5625	1524	6.9	1588	7.2	1652	7.5	1716	7.8	1780	8.1
6000	1617	7.3	1677	7.6	1737	7.9	1797	8.1	1857	8.4
6375	1711	7.7	1767	8.0	1824	8.3	1881	8.5	1937	8.8
6750	1805	8.2	1858	8.4	1912	8.7	1965	8.9	2019	9.2
7125	1899	8.6	1950	8.8	2001	9.1	2051	9.3	2102	9.5
7500	1994	9.0	2042	9.3	2090	9.5	2139	9.7	2187	9.9

CFM	AVAILABLE EXTERNAL STATIC PRESSURE (in. wg)									
	1.2		1.4		1.6		1.8		2.0	
	rpm	Vdc	rpm	Vdc	rpm	Vdc	rpm	Vdc	rpm	Vdc
4500	1642	7.4	1717	7.8	1790	8.1	1861	8.4	1929	8.7
4875	1705	7.7	1776	8.0	1845	8.4	1913	8.7	1979	9.0
5250	1773	8.0	1839	8.3	1905	8.6	1970	8.9	2033	9.2
5625	1843	8.4	1906	8.6	1968	8.9	2030	9.2	2090	9.5
6000	1917	8.7	1976	9.0	2035	9.2	2094	9.5	2151	9.8
6375	1993	9.0	2050	9.3	2105	9.6	2161	9.8	—	—
6750	2072	9.4	2125	9.7	2178	9.9	—	—	—	—
7125	2153	9.8	—	—	—	—	—	—	—	—
7500	—	—	—	—	—	—	—	—	—	—

High Static 1248-2200 rpm

## 50FC-M08 — 7.5 TON VERTICAL SUPPLY (RPM - BHP)

CFM	AVAILABLE EXTERNAL STATIC PRESSURE (in. wg)									
	0.2		0.4		0.6		0.8		1.0	
	rpm	bhp	rpm	bhp	rpm	bhp	rpm	bhp	rpm	bhp
2250	970	0.34	1102	0.50	1216	0.68	1319	0.86	1414	1.07
2440	1031	0.41	1157	0.58	1267	0.76	1367	0.96	1459	1.17
2625	1092	0.49	1213	0.67	1320	0.86	1416	1.06	1506	1.28
2810	1155	0.57	1271	0.76	1374	0.96	1467	1.17	1554	1.39
3000	1219	0.66	1330	0.86	1429	1.07	1520	1.29	1605	1.52
3190	1284	0.77	1390	0.97	1486	1.19	1574	1.41	1656	1.64
3375	1349	0.87	1451	1.09	1544	1.31	1629	1.54	1709	1.78
3560	1415	0.99	1513	1.21	1603	1.44	1686	1.68	1764	1.92
3750	1481	1.11	1576	1.34	1662	1.57	1743	1.81	1819	2.06

CFM	AVAILABLE EXTERNAL STATIC PRESSURE (in. wg)									
	1.2		1.4		1.6		1.8		2.0	
	rpm	bhp	rpm	bhp	rpm	bhp	rpm	bhp	rpm	bhp
2250	1502	1.28	1585	1.50	1664	1.74	1739	1.98	1810	2.23
2440	1545	1.38	1626	1.61	1703	1.85	1777	2.11	1847	2.37
2625	1589	1.50	1669	1.74	1745	1.98	1817	2.24	1886	2.51
2810	1636	1.62	1713	1.86	1788	2.12	1858	2.38	1926	2.65
3000	1684	1.75	1760	2.00	1832	2.26	1901	2.52	1968	2.80
3190	1734	1.89	1808	2.14	1878	2.40	1946	2.67	2012	2.95
3375	1785	2.03	1857	2.28	1926	2.55	1992	2.82	2057	3.10
3560	1837	2.17	1908	2.43	1975	2.69	2040	2.97	—	—
3750	1891	2.31	1960	2.57	2026	2.84	2089	3.11	—	—

Std/Med Static 970-2000 rpm, 2.4 Max bhp

High Static 970-2200 rpm, 3.0 Max bhp

## 50FC-M08 – STANDARD/MEDIUM STATIC — 7.5 TON VERTICAL SUPPLY (RPM - VDC)

CFM	AVAILABLE EXTERNAL STATIC PRESSURE (in. wg)									
	0.2		0.4		0.6		0.8		1.0	
	rpm	Vdc	rpm	Vdc	rpm	Vdc	rpm	Vdc	rpm	Vdc
2250	970	4.7	1102	5.4	1216	6.0	1319	6.5	1414	7.0
2440	1031	5.0	1157	5.7	1267	6.2	1367	6.7	1459	7.2
2625	1092	5.3	1213	6.0	1320	6.5	1416	7.0	1506	7.5
2810	1155	5.7	1271	6.3	1374	6.8	1467	7.3	1554	7.7
3000	1219	6.0	1330	6.6	1429	7.1	1520	7.5	1605	8.0
3190	1284	6.3	1390	6.9	1486	7.4	1574	7.8	1656	8.2
3375	1349	6.7	1451	7.2	1544	7.7	1629	8.1	1709	8.5
3560	1415	7.0	1513	7.5	1603	8.0	1686	8.4	1764	8.8
3750	1481	7.3	1576	7.8	1662	8.3	1743	8.7	1819	9.1

CFM	AVAILABLE EXTERNAL STATIC PRESSURE (in. wg)									
	1.2		1.4		1.6		1.8		2.0	
	rpm	Vdc	rpm	Vdc	rpm	Vdc	rpm	Vdc	rpm	Vdc
2250	1502	7.4	1585	7.9	1664	8.3	1739	8.7	1810	9.0
2440	1545	7.7	1626	8.1	1703	8.5	1777	8.9	1847	9.2
2625	1589	7.9	1669	8.3	1745	8.7	1817	9.1	—	—
2810	1636	8.1	1713	8.5	1788	8.9	1858	9.3	—	—
3000	1684	8.4	1760	8.8	1832	9.1	—	—	—	—
3190	1734	8.6	1808	9.0	1878	9.4	—	—	—	—
3375	1785	8.9	1857	9.3	—	—	—	—	—	—
3560	1837	9.2	—	—	—	—	—	—	—	—
3750	1891	9.4	—	—	—	—	—	—	—	—

Std/Med Static 970-2000 rpm

## 50FC-M08 – HIGH STATIC — 7.5 TON VERTICAL SUPPLY (RPM - VDC)

CFM	AVAILABLE EXTERNAL STATIC PRESSURE (in. wg)									
	0.2		0.4		0.6		0.8		1.0	
	rpm	Vdc	rpm	Vdc	rpm	Vdc	rpm	Vdc	rpm	Vdc
2250	970	4.3	1102	4.9	1216	5.5	1319	5.9	1414	6.4
2440	1031	4.6	1157	5.2	1267	5.7	1367	6.2	1459	6.6
2625	1092	4.9	1213	5.4	1320	5.9	1416	6.4	1506	6.8
2810	1155	5.2	1271	5.7	1374	6.2	1467	6.6	1554	7.0
3000	1219	5.5	1330	6.0	1429	6.4	1520	6.9	1605	7.3
3190	1284	5.8	1390	6.3	1486	6.7	1574	7.1	1656	7.5
3375	1349	6.1	1451	6.5	1544	7.0	1629	7.4	1709	7.7
3560	1415	6.4	1513	6.8	1603	7.2	1686	7.6	1764	8.0
3750	1481	6.7	1576	7.1	1662	7.5	1743	7.9	1819	8.2

CFM	AVAILABLE EXTERNAL STATIC PRESSURE (in. wg)									
	1.2		1.4		1.6		1.8		2.0	
	rpm	Vdc	rpm	Vdc	rpm	Vdc	rpm	Vdc	rpm	Vdc
2250	1502	6.8	1585	7.2	1664	7.5	1739	7.9	1810	8.2
2440	1545	7.0	1626	7.4	1703	7.7	1777	8.0	1847	8.4
2625	1589	7.2	1669	7.5	1745	7.9	1817	8.2	1886	8.6
2810	1636	7.4	1713	7.8	1788	8.1	1858	8.4	1926	8.7
3000	1684	7.6	1760	8.0	1832	8.3	1901	8.6	1968	8.9
3190	1734	7.8	1808	8.2	1878	8.5	1946	8.8	2012	9.1
3375	1785	8.1	1857	8.4	1926	8.7	1992	9.0	2057	9.3
3560	1837	8.3	1908	8.7	1975	9.0	2040	9.3	—	—
3750	1891	8.6	1960	8.9	2026	9.2	2089	9.5	—	—

High Static 970-2200 rpm

## 50FC-M09 — 8.5 TON VERTICAL SUPPLY (RPM - BHP)

CFM	AVAILABLE EXTERNAL STATIC PRESSURE (in. wg)									
	0.2		0.4		0.6		0.8		1.0	
	rpm	bhp	rpm	bhp	rpm	bhp	rpm	bhp	rpm	bhp
2550	1015	0.39	1128	0.53	1233	0.69	1330	0.87	1421	1.06
2760	1084	0.47	1190	0.62	1289	0.78	1382	0.96	1470	1.16
2975	1154	0.56	1253	0.71	1348	0.89	1437	1.07	1521	1.27
3190	1225	0.66	1319	0.82	1408	1.00	1493	1.19	1574	1.39
3400	1297	0.77	1386	0.94	1470	1.12	1551	1.31	1629	1.52
3610	1370	0.89	1453	1.06	1534	1.25	1612	1.45	1687	1.66
3825	1443	1.02	1522	1.19	1599	1.38	1673	1.58	1745	1.80
4040	1517	1.15	1592	1.33	1665	1.52	1736	1.73	1806	1.94
4250	1591	1.29	1663	1.47	1733	1.67	1801	1.87	1867	2.09

CFM	AVAILABLE EXTERNAL STATIC PRESSURE (in. wg)									
	1.2		1.4		1.6		1.8		2.0	
	rpm	bhp	rpm	bhp	rpm	bhp	rpm	bhp	rpm	bhp
2550	1506	1.26	1586	1.47	1662	1.69	1734	1.92	1802	2.16
2760	1552	1.37	1630	1.58	1705	1.81	1776	2.05	1843	2.29
2975	1601	1.48	1677	1.70	1750	1.94	1819	2.17	1886	2.42
3190	1652	1.61	1726	1.84	1796	2.07	1864	2.31	1930	2.57
3400	1704	1.74	1776	1.97	1845	2.21	1911	2.45	1975	2.71
3610	1759	1.88	1828	2.11	1895	2.35	1960	2.60	2023	2.86
3825	1815	2.02	1882	2.25	1947	2.50	2011	2.75	2072	3.01
4040	1873	2.17	1938	2.40	2001	2.64	2063	2.90	2122	3.15
4250	1932	2.31	1995	2.54	2056	2.78	2116	3.04	—	—

Std/Med Static 1015-2000 rpm, 2.4 Max bhp

High Static 1015-2200 rpm, 3.0 Max bhp

## 50FC-M09 – STANDARD/MEDIUM STATIC — 8.5 TON VERTICAL SUPPLY (RPM - VDC)

CFM	AVAILABLE EXTERNAL STATIC PRESSURE (in. wg)									
	0.2		0.4		0.6		0.8		1.0	
	rpm	Vdc	rpm	Vdc	rpm	Vdc	rpm	Vdc	rpm	Vdc
2550	1015	4.9	1128	5.5	1233	6.1	1330	6.6	1421	7.0
2760	1084	5.3	1190	5.8	1289	6.3	1382	6.8	1470	7.3
2975	1154	5.6	1253	6.2	1348	6.6	1437	7.1	1521	7.5
3190	1225	6.0	1319	6.5	1408	7.0	1493	7.4	1574	7.8
3400	1297	6.4	1386	6.8	1470	7.3	1551	7.7	1629	8.1
3610	1370	6.8	1453	7.2	1534	7.6	1612	8.0	1687	8.4
3825	1443	7.1	1522	7.5	1599	7.9	1673	8.3	1745	8.7
4040	1517	7.5	1592	7.9	1665	8.3	1736	8.6	1806	9.0
4250	1591	7.9	1663	8.3	1733	8.6	1801	9.0	1867	9.3

CFM	AVAILABLE EXTERNAL STATIC PRESSURE (in. wg)									
	1.2		1.4		1.6		1.8		2.0	
	rpm	Vdc	rpm	Vdc	rpm	Vdc	rpm	Vdc	rpm	Vdc
2550	1506	7.5	1586	7.9	1662	8.3	1734	8.6	1802	9.0
2760	1552	7.7	1630	8.1	1705	8.5	1776	8.8	1843	9.2
2975	1601	7.9	1677	8.3	1750	8.7	1819	9.1	—	—
3190	1652	8.2	1726	8.6	1796	9.0	—	—	—	—
3400	1704	8.5	1776	8.8	1845	9.2	—	—	—	—
3610	1759	8.8	1828	9.1	1895	9.5	—	—	—	—
3825	1815	9.0	1882	9.4	—	—	—	—	—	—
4040	1873	9.3	—	—	—	—	—	—	—	—
4250	1932	9.7	—	—	—	—	—	—	—	—

Std/Med Static 1015-2000 rpm

## 50FC-M09 – HIGH STATIC — 8.5 TON VERTICAL SUPPLY (RPM - VDC)

CFM	AVAILABLE EXTERNAL STATIC PRESSURE (in. wg)									
	0.2		0.4		0.6		0.8		1.0	
	rpm	Vdc	rpm	Vdc	rpm	Vdc	rpm	Vdc	rpm	Vdc
2550	1015	4.5	1128	5.1	1233	5.5	1330	6.0	1421	6.4
2760	1084	4.8	1190	5.3	1289	5.8	1382	6.2	1470	6.6
2975	1154	5.2	1253	5.6	1348	6.1	1437	6.5	1521	6.9
3190	1225	5.5	1319	5.9	1408	6.3	1493	6.7	1574	7.1
3400	1297	5.8	1386	6.2	1470	6.6	1551	7.0	1629	7.4
3610	1370	6.2	1453	6.6	1534	6.9	1612	7.3	1687	7.6
3825	1443	6.5	1522	6.9	1599	7.2	1673	7.6	1745	7.9
4040	1517	6.8	1592	7.2	1665	7.5	1736	7.9	1806	8.2
4250	1591	7.2	1663	7.5	1733	7.8	1801	8.2	1867	8.5

CFM	AVAILABLE EXTERNAL STATIC PRESSURE (in. wg)									
	1.2		1.4		1.6		1.8		2.0	
	rpm	Vdc	rpm	Vdc	rpm	Vdc	rpm	Vdc	rpm	Vdc
2550	1506	6.8	1586	7.2	1662	7.5	1734	7.8	1802	8.2
2760	1552	7.0	1630	7.4	1705	7.7	1776	8.0	1843	8.4
2975	1601	7.2	1677	7.6	1750	7.9	1819	8.2	1886	8.6
3190	1652	7.5	1726	7.8	1796	8.1	1864	8.4	1930	8.8
3400	1704	7.7	1776	8.0	1845	8.4	1911	8.7	1975	9.0
3610	1759	8.0	1828	8.3	1895	8.6	1960	8.9	2023	9.2
3825	1815	8.2	1882	8.5	1947	8.8	2011	9.1	2072	9.4
4040	1873	8.5	1938	8.8	2001	9.1	2063	9.4	2122	9.6
4250	1932	8.8	1995	9.1	2056	9.3	2116	9.6	—	—

High Static 1015-2200 rpm

## 50FC-M12 — 10 TON VERTICAL SUPPLY (RPM - BHP)

CFM	AVAILABLE EXTERNAL STATIC PRESSURE (in. wg)									
	0.2		0.4		0.6		0.8		1.0	
	rpm	bhp	rpm	bhp	rpm	bhp	rpm	bhp	rpm	bhp
3000	1181	0.60	1279	0.77	1372	0.95	1461	1.14	1544	1.35
3250	1264	0.73	1356	0.91	1443	1.09	1527	1.29	1607	1.51
3500	1348	0.88	1434	1.06	1517	1.25	1596	1.46	1673	1.68
3750	1433	1.04	1514	1.23	1592	1.43	1667	1.64	1740	1.86
4000	1518	1.21	1595	1.41	1669	1.61	1740	1.83	1810	2.06
4250	1605	1.41	1677	1.60	1747	1.81	1815	2.03	1882	2.27
4500	1691	1.60	1760	1.81	1826	2.02	1892	2.24	1955	2.48
4750	1778	1.81	1843	2.01	1907	2.23	1969	2.46	2030	2.69
5000	1866	2.02	1928	2.23	1988	2.44	2048	2.67	2106	2.91

CFM	AVAILABLE EXTERNAL STATIC PRESSURE (in. wg)									
	1.2		1.4		1.6		1.8		2.0	
	rpm	bhp	rpm	bhp	rpm	bhp	rpm	bhp	rpm	bhp
3000	1624	1.57	1699	1.80	1771	2.04	1840	2.29	1906	2.54
3250	1684	1.73	1757	1.97	1827	2.21	1894	2.47	1958	2.72
3500	1746	1.91	1817	2.15	1884	2.40	1950	2.66	2013	2.92
3750	1811	2.10	1879	2.34	1945	2.60	2008	2.86	2070	3.13
4000	1878	2.30	1943	2.55	2007	2.81	2069	3.08	2128	3.35
4250	1947	2.51	2010	2.76	2071	3.02	2131	3.29	2189	3.56
4500	2017	2.72	2078	2.97	2138	3.24	2195	3.50	—	—
4750	2090	2.94	2148	3.19	—	—	—	—	—	—
5000	2164	3.15	—	—	—	—	—	—	—	—

Std/Med Static 1181-2000 rpm, 2.4 Max bhp

High Static 1181-2200 rpm, 5.0 Max bhp

## 50FC-M12 – STANDARD/MEDIUM STATIC — 10 TON VERTICAL SUPPLY (RPM - VDC)

CFM	AVAILABLE EXTERNAL STATIC PRESSURE (in. wg)									
	0.2		0.4		0.6		0.8		1.0	
	rpm	Vdc	rpm	Vdc	rpm	Vdc	rpm	Vdc	rpm	Vdc
3000	1181	5.8	1279	6.3	1372	6.8	1461	7.2	1544	7.7
3250	1264	6.2	1356	6.7	1443	7.1	1527	7.6	1607	8.0
3500	1348	6.6	1434	7.1	1517	7.5	1596	7.9	1673	8.3
3750	1433	7.1	1514	7.5	1592	7.9	1667	8.3	1740	8.7
4000	1518	7.5	1595	7.9	1669	8.3	1740	8.7	1810	9.0
4250	1605	8.0	1677	8.3	1747	8.7	1815	9.0	1882	9.4
4500	1691	8.4	1760	8.8	1826	9.1	1892	9.4	—	—
4750	1778	8.9	1843	9.2	1907	9.5	—	—	—	—
5000	1866	9.3	1928	9.6	1988	9.9	—	—	—	—

CFM	AVAILABLE EXTERNAL STATIC PRESSURE (in. wg)									
	1.2		1.4		1.6		1.8		2.0	
	rpm	Vdc	rpm	Vdc	rpm	Vdc	rpm	Vdc	rpm	Vdc
3000	1624	8.1	1699	8.5	1771	8.8	1840	9.2	—	—
3250	1684	8.4	1757	8.8	1827	9.1	—	—	—	—
3500	1746	8.7	1817	9.1	1884	9.4	—	—	—	—
3750	1811	9.0	1879	9.4	—	—	—	—	—	—
4000	1878	9.4	—	—	—	—	—	—	—	—
4250	—	—	—	—	—	—	—	—	—	—
4500	—	—	—	—	—	—	—	—	—	—
4750	—	—	—	—	—	—	—	—	—	—
5000	—	—	—	—	—	—	—	—	—	—

Std/Med Static 1181-2000 rpm

## 50FC-M12 – HIGH STATIC — 10 TON VERTICAL SUPPLY (RPM - VDC)

CFM	AVAILABLE EXTERNAL STATIC PRESSURE (in. wg)									
	0.2		0.4		0.6		0.8		1.0	
	rpm	Vdc	rpm	Vdc	rpm	Vdc	rpm	Vdc	rpm	Vdc
3000	1181	5.3	1279	5.7	1372	6.2	1461	6.6	1544	7.0
3250	1264	5.7	1356	6.1	1443	6.5	1527	6.9	1607	7.3
3500	1348	6.1	1434	6.5	1517	6.8	1596	7.2	1673	7.6
3750	1433	6.5	1514	6.8	1592	7.2	1667	7.5	1740	7.9
4000	1518	6.9	1595	7.2	1669	7.5	1740	7.9	1810	8.2
4250	1605	7.3	1677	7.6	1747	7.9	1815	8.2	1882	8.5
4500	1691	7.7	1760	8.0	1826	8.3	1892	8.6	1955	8.9
4750	1778	8.1	1843	8.4	1907	8.6	1969	8.9	2030	9.2
5000	1866	8.5	1928	8.7	1988	9.0	2048	9.3	2106	9.6

CFM	AVAILABLE EXTERNAL STATIC PRESSURE (in. wg)									
	1.2		1.4		1.6		1.8		2.0	
	rpm	Vdc	rpm	Vdc	rpm	Vdc	rpm	Vdc	rpm	Vdc
3000	1624	7.3	1699	7.7	1771	8.0	1840	8.3	1906	8.6
3250	1684	7.6	1757	8.0	1827	8.3	1894	8.6	1958	8.9
3500	1746	7.9	1817	8.2	1884	8.5	1950	8.8	2013	9.1
3750	1811	8.2	1879	8.5	1945	8.8	2008	9.1	2070	9.4
4000	1878	8.5	1943	8.8	2007	9.1	2069	9.4	2128	9.7
4250	1947	8.8	2010	9.1	2071	9.4	2131	9.7	2189	9.9
4500	2017	9.2	2078	9.4	2138	9.7	2195	10.0	—	—
4750	2090	9.5	2148	9.8	—	—	—	—	—	—
5000	2164	9.8	—	—	—	—	—	—	—	—

High Static 1181-2200 rpm

## 50FC-M14 — 12.5 TON VERTICAL SUPPLY (RPM - BHP)

CFM	AVAILABLE EXTERNAL STATIC PRESSURE (in. wg)									
	0.2		0.4		0.6		0.8		1.0	
	rpm	bhp	rpm	bhp	rpm	bhp	rpm	bhp	rpm	bhp
3750	1178	0.86	1287	1.12	1386	1.40	1475	1.69	1558	1.99
4060	1260	1.05	1362	1.32	1456	1.62	1543	1.92	1623	2.24
4375	1343	1.26	1438	1.55	1528	1.86	1612	2.19	1690	2.52
4690	1426	1.51	1516	1.81	1602	2.14	1683	2.48	1759	2.83
5000	1511	1.78	1595	2.09	1677	2.43	1755	2.79	1828	3.15
5310	1596	2.08	1675	2.41	1753	2.76	1828	3.13	1899	3.51
5625	1681	2.41	1756	2.74	1830	3.10	1902	3.49	1971	3.88
5940	1767	2.76	1838	3.10	1909	3.48	1978	3.87	2045	4.28
6250	1854	3.14	1921	3.49	1989	3.88	2055	4.27	2119	4.69

CFM	AVAILABLE EXTERNAL STATIC PRESSURE (in. wg)									
	1.2		1.4		1.6		1.8		2.0	
	rpm	bhp	rpm	bhp	rpm	bhp	rpm	bhp	rpm	bhp
3750	1634	2.29	1705	2.61	1772	2.93	1837	3.26	1898	3.60
4060	1698	2.57	1768	2.90	1834	3.23	1897	3.58	1957	3.93
4375	1763	2.86	1832	3.21	1897	3.56	1959	3.92	2018	4.29
4690	1830	3.18	1897	3.55	1961	3.92	2022	4.29	2081	4.68
5000	1898	3.53	1964	3.91	2027	4.30	2087	4.69	2144	5.09
5310	1967	3.90	2031	4.29	2093	4.69	2152	5.10	—	—
5625	2037	4.28	2100	4.69	2161	5.11	—	—	—	—
5940	2109	4.69	2170	5.11	—	—	—	—	—	—
6250	2181	5.11	—	—	—	—	—	—	—	—

Std/Med Static 1178-2200 rpm, 3.0 Max bhp

High Static 1178-2200 rpm, 5.0 Max bhp

## 50FC-M14 – STANDARD/MEDIUM STATIC — 12.5 TON VERTICAL SUPPLY (RPM - VDC)

CFM	AVAILABLE EXTERNAL STATIC PRESSURE (in. wg)									
	0.2		0.4		0.6		0.8		1.0	
	rpm	Vdc	rpm	Vdc	rpm	Vdc	rpm	Vdc	rpm	Vdc
3750	1178	5.3	1287	5.8	1386	6.2	1475	6.7	1558	7.0
4060	1260	5.7	1362	6.1	1456	6.6	1543	7.0	1623	7.3
4375	1343	6.0	1438	6.5	1528	6.9	1612	7.3	1690	7.6
4690	1426	6.4	1516	6.8	1602	7.2	1683	7.6	1759	8.0
5000	1511	6.8	1595	7.2	1677	7.6	1755	7.9	—	—
5310	1596	7.2	1675	7.6	1753	7.9	—	—	—	—
5625	1681	7.6	1756	8.0	—	—	—	—	—	—
5940	1767	8.0	—	—	—	—	—	—	—	—
6250	—	—	—	—	—	—	—	—	—	—

CFM	AVAILABLE EXTERNAL STATIC PRESSURE (in. wg)									
	1.2		1.4		1.6		1.8		2.0	
	rpm	Vdc	rpm	Vdc	rpm	Vdc	rpm	Vdc	rpm	Vdc
3750	1634	7.4	1705	7.7	1772	8.0	—	—	—	—
4060	1698	7.7	1768	8.0	—	—	—	—	—	—
4375	1763	8.0	—	—	—	—	—	—	—	—
4690	—	—	—	—	—	—	—	—	—	—
5000	—	—	—	—	—	—	—	—	—	—
5310	—	—	—	—	—	—	—	—	—	—
5625	—	—	—	—	—	—	—	—	—	—
5940	—	—	—	—	—	—	—	—	—	—
6250	—	—	—	—	—	—	—	—	—	—

Std/Med Static 1178-2200 rpm



## 50FC-M14 – HIGH STATIC — 12.5 TON VERTICAL SUPPLY (RPM - VDC)

CFM	AVAILABLE EXTERNAL STATIC PRESSURE (in. wg)									
	0.2		0.4		0.6		0.8		1.0	
	rpm	Vdc	rpm	Vdc	rpm	Vdc	rpm	Vdc	rpm	Vdc
3750	1178	5.3	1287	5.8	1386	6.2	1475	6.7	1558	7.0
4060	1260	5.7	1362	6.1	1456	6.6	1543	7.0	1623	7.3
4375	1343	6.0	1438	6.5	1528	6.9	1612	7.3	1690	7.6
4690	1426	6.4	1516	6.8	1602	7.2	1683	7.6	1759	8.0
5000	1511	6.8	1595	7.2	1677	7.6	1755	7.9	1828	8.3
5310	1596	7.2	1675	7.6	1753	7.9	1828	8.3	1899	8.6
5625	1681	7.6	1756	8.0	1830	8.3	1902	8.6	1971	8.9
5940	1767	8.0	1838	8.3	1909	8.7	1978	9.0	2045	9.3
6250	1854	8.4	1921	8.7	1989	9.0	2055	9.3	2119	9.6

CFM	AVAILABLE EXTERNAL STATIC PRESSURE (in. wg)									
	1.2		1.4		1.6		1.8		2.0	
	rpm	Vdc	rpm	Vdc	rpm	Vdc	rpm	Vdc	rpm	Vdc
3750	1634	7.4	1705	7.7	1772	8.0	1837	8.3	1898	8.6
4060	1698	7.7	1768	8.0	1834	8.3	1897	8.6	1957	8.9
4375	1763	8.0	1832	8.3	1897	8.6	1959	8.9	2018	9.2
4690	1830	8.3	1897	8.6	1961	8.9	2022	9.2	2081	9.5
5000	1898	8.6	1964	8.9	2027	9.2	2087	9.5	2144	9.7
5310	1967	8.9	2031	9.2	2093	9.5	2152	9.8	—	—
5625	2037	9.2	2100	9.5	2161	9.8	—	—	—	—
5940	2109	9.6	2170	9.9	—	—	—	—	—	—
6250	2181	9.9	—	—	—	—	—	—	—	—

High Static 1178-2200 rpm

## 50FC-M16 — 15 TON VERTICAL SUPPLY (RPM - BHP)

CFM	AVAILABLE EXTERNAL STATIC PRESSURE (in. wg)									
	0.2		0.4		0.6		0.8		1.0	
	rpm	bhp	rpm	bhp	rpm	bhp	rpm	bhp	rpm	bhp
4500	1120	0.73	1201	0.90	1281	1.10	1361	1.32	1441	1.56
4875	1208	0.92	1283	1.10	1357	1.30	1431	1.52	1505	1.77
5250	1297	1.12	1367	1.32	1436	1.52	1504	1.75	1573	2.00
5625	1387	1.36	1452	1.56	1516	1.77	1581	2.01	1645	2.26
6000	1477	1.61	1538	1.82	1598	2.04	1659	2.28	1719	2.54
6375	1568	1.89	1625	2.10	1682	2.33	1739	2.58	1796	2.84
6750	1659	2.20	1713	2.42	1767	2.66	1821	2.91	1874	3.17
7125	1751	2.56	1802	2.79	1891	3.23	1904	3.29	1955	3.56
7500	1842	2.99	1891	3.23	1891	3.23	1988	3.75	2036	4.03

CFM	AVAILABLE EXTERNAL STATIC PRESSURE (in. wg)									
	1.2		1.4		1.6		1.8		2.0	
	rpm	bhp	rpm	bhp	rpm	bhp	rpm	bhp	rpm	bhp
4500	1520	1.83	1597	2.13	1673	2.45	1747	2.79	1818	3.14
4875	1579	2.05	1651	2.34	1723	2.66	1793	2.99	1861	3.35
5250	1642	2.28	1710	2.57	1777	2.89	1844	3.23	1909	3.58
5625	1709	2.54	1773	2.83	1836	3.14	1899	3.48	1961	3.83
6000	1779	2.81	1840	3.11	1899	3.42	1959	3.76	2018	4.11
6375	1853	3.12	1909	3.41	1966	3.73	2022	4.05	2078	4.40
6750	1928	3.45	1982	3.75	2035	4.06	2089	4.39	2142	4.73
7125	2006	3.84	2056	4.14	2107	4.46	2158	4.79	—	—
7500	2085	4.33	2133	4.64	2181	4.96	—	—	—	—

Std/Med Static 1120-2200 rpm, 3.0 Max bhp

High Static 1120-2200 rpm, 5.0 Max bhp

## 50FC-M16 – STANDARD/MEDIUM STATIC — 15 TON VERTICAL SUPPLY (RPM - VDC)

CFM	AVAILABLE EXTERNAL STATIC PRESSURE (in. wg)									
	0.2		0.4		0.6		0.8		1.0	
	rpm	Vdc	rpm	Vdc	rpm	Vdc	rpm	Vdc	rpm	Vdc
4500	1120	5.0	1201	5.4	1281	5.8	1361	6.1	1441	6.5
4875	1208	5.4	1283	5.8	1357	6.1	1431	6.5	1505	6.8
5250	1297	5.8	1367	6.2	1436	6.5	1504	6.8	1573	7.1
5625	1387	6.2	1452	6.5	1516	6.8	1581	7.1	1645	7.4
6000	1477	6.7	1538	6.9	1598	7.2	1659	7.5	1719	7.8
6375	1568	7.1	1625	7.3	1682	7.6	1739	7.9	1796	8.1
6750	1659	7.5	1713	7.8	1767	8.0	1821	8.3	—	—
7125	1751	7.9	1802	8.2	—	—	—	—	—	—
7500	1842	8.3	—	—	—	—	—	—	—	—

CFM	AVAILABLE EXTERNAL STATIC PRESSURE (in. wg)									
	1.2		1.4		1.6		1.8		2.0	
	rpm	Vdc	rpm	Vdc	rpm	Vdc	rpm	Vdc	rpm	Vdc
4500	1520	6.9	1597	7.2	1673	7.6	1747	7.9	—	—
4875	1579	7.1	1651	7.5	1723	7.8	1793	8.1	—	—
5250	1642	7.4	1710	7.7	1777	8.0	—	—	—	—
5625	1709	7.7	1773	8.0	1836	8.3	—	—	—	—
6000	1779	8.1	1840	8.3	—	—	—	—	—	—
6375	—	—	—	—	—	—	—	—	—	—
6750	—	—	—	—	—	—	—	—	—	—
7125	—	—	—	—	—	—	—	—	—	—
7500	—	—	—	—	—	—	—	—	—	—

Std/Med Static 1120-2200 rpm

## 50FC-M16 – HIGH STATIC — 15 TON VERTICAL SUPPLY (RPM - VDC)

CFM	AVAILABLE EXTERNAL STATIC PRESSURE (in. wg)									
	0.2		0.4		0.6		0.8		1.0	
	rpm	Vdc	rpm	Vdc	rpm	Vdc	rpm	Vdc	rpm	Vdc
4500	1120	5.0	1201	5.4	1281	5.8	1361	6.1	1441	6.5
4875	1208	5.4	1283	5.8	1357	6.1	1431	6.5	1505	6.8
5250	1297	5.8	1367	6.2	1436	6.5	1504	6.8	1573	7.1
5625	1387	6.2	1452	6.5	1516	6.8	1581	7.1	1645	7.4
6000	1477	6.7	1538	6.9	1598	7.2	1659	7.5	1719	7.8
6375	1568	7.1	1625	7.3	1682	7.6	1739	7.9	1796	8.1
6750	1659	7.5	1713	7.8	1767	8.0	1821	8.3	1874	8.5
7125	1751	7.9	1802	8.2	1853	8.4	1904	8.6	1955	8.9
7500	1842	8.3	1891	8.6	1940	8.8	1988	9.0	2036	9.2

CFM	AVAILABLE EXTERNAL STATIC PRESSURE (in. wg)									
	1.2		1.4		1.6		1.8		2.0	
	rpm	Vdc	rpm	Vdc	rpm	Vdc	rpm	Vdc	rpm	Vdc
4500	1520	6.9	1597	7.2	1673	7.6	1747	7.9	1818	8.2
4875	1579	7.1	1651	7.5	1723	7.8	1793	8.1	1861	8.4
5250	1642	7.4	1710	7.7	1777	8.0	1844	8.4	1909	8.7
5625	1709	7.7	1773	8.0	1836	8.3	1899	8.6	1961	8.9
6000	1779	8.1	1840	8.3	1899	8.6	1959	8.9	2018	9.2
6375	1853	8.4	1909	8.7	1966	8.9	2022	9.2	2078	9.4
6750	1928	8.7	1982	9.0	2035	9.2	2089	9.5	2142	9.7
7125	2006	9.1	2056	9.3	2107	9.6	2158	9.8	—	—
7500	2085	9.5	2133	9.7	2181	9.9	—	—	—	—

High Static 1120-2200 rpm

## 50FC-M08 — 7.5 TON HORIZONTAL SUPPLY (RPM - BHP)

CFM	AVAILABLE EXTERNAL STATIC PRESSURE (in. wg)									
	0.2		0.4		0.6		0.8		1.0	
	rpm	bhp	rpm	bhp	rpm	bhp	rpm	bhp	rpm	bhp
2250	910	0.28	1046	0.43	1167	0.60	1276	0.78	1376	0.98
2440	966	0.34	1095	0.49	1211	0.67	1316	0.86	1414	1.06
2625	1023	0.40	1145	0.56	1256	0.74	1359	0.94	1453	1.15
2810	1081	0.47	1197	0.64	1304	0.82	1403	1.02	1495	1.24
3000	1141	0.54	1251	0.72	1353	0.91	1449	1.12	1538	1.33
3190	1200	0.63	1306	0.81	1404	1.00	1496	1.21	1583	1.44
3375	1261	0.71	1361	0.90	1456	1.10	1545	1.31	1629	1.54
3560	1322	0.81	1418	1.00	1509	1.20	1595	1.42	1677	1.65
3750	1384	0.91	1476	1.10	1563	1.30	1646	1.52	1725	1.75

CFM	AVAILABLE EXTERNAL STATIC PRESSURE (in. wg)									
	1.2		1.4		1.6		1.8		2.0	
	rpm	bhp	rpm	bhp	rpm	bhp	rpm	bhp	rpm	bhp
2250	1469	1.19	1556	1.42	1639	1.66	1716	1.90	1790	2.16
2440	1505	1.28	1590	1.51	1671	1.75	1748	2.01	1821	2.27
2625	1542	1.37	1626	1.61	1705	1.85	1781	2.11	1853	2.38
2810	1581	1.46	1663	1.70	1741	1.96	1816	2.22	1887	2.49
3000	1622	1.57	1702	1.81	1778	2.06	1852	2.33	1922	2.60
3190	1665	1.67	1743	1.92	1818	2.18	1889	2.44	1958	2.72
3375	1709	1.78	1785	2.03	1858	2.29	1928	2.55	1996	2.83
3560	1755	1.89	1829	2.14	1900	2.40	1969	2.67	2035	2.95
3750	1801	2.00	1874	2.25	1944	2.51	2011	2.78	2076	3.06

Std/Med Static 910-2000 rpm, 2.4 Max bhp

High Static 910-2200 rpm, 3.0 Max bhp

## 50FC-M08 – STANDARD/MEDIUM STATIC — 7.5 TON HORIZONTAL SUPPLY (RPM - VDC)

CFM	AVAILABLE EXTERNAL STATIC PRESSURE (in. wg)									
	0.2		0.4		0.6		0.8		1.0	
	rpm	Vdc	rpm	Vdc	rpm	Vdc	rpm	Vdc	rpm	Vdc
2250	910	4.4	1046	5.1	1167	5.7	1276	6.3	1376	6.8
2440	966	4.7	1095	5.3	1211	5.9	1316	6.5	1414	7.0
2625	1023	5.0	1145	5.6	1256	6.2	1359	6.7	1453	7.2
2810	1081	5.3	1197	5.9	1304	6.4	1403	6.9	1495	7.4
3000	1141	5.6	1251	6.1	1353	6.7	1449	7.2	1538	7.6
3190	1200	5.9	1306	6.4	1404	6.9	1496	7.4	1583	7.9
3375	1261	6.2	1361	6.7	1456	7.2	1545	7.7	1629	8.1
3560	1322	6.5	1418	7.0	1509	7.5	1595	7.9	1677	8.3
3750	1384	6.8	1476	7.3	1563	7.8	1646	8.2	1725	8.6

CFM	AVAILABLE EXTERNAL STATIC PRESSURE (in. wg)									
	1.2		1.4		1.6		1.8		2.0	
	rpm	Vdc	rpm	Vdc	rpm	Vdc	rpm	Vdc	rpm	Vdc
2250	1469	7.3	1556	7.7	1639	8.1	1716	8.5	1790	8.9
2440	1505	7.5	1590	7.9	1671	8.3	1748	8.7	1821	9.1
2625	1542	7.6	1626	8.1	1705	8.5	1781	8.9	1853	9.2
2810	1581	7.8	1663	8.3	1741	8.7	1816	9.1	—	—
3000	1622	8.1	1702	8.5	1778	8.9	1852	9.2	—	—
3190	1665	8.3	1743	8.7	1818	9.1	—	—	—	—
3375	1709	8.5	1785	8.9	1858	9.3	—	—	—	—
3560	1755	8.7	1829	9.1	—	—	—	—	—	—
3750	1801	9.0	1874	9.4	—	—	—	—	—	—

Std/Med Static 910-2000 rpm

## 50FC-M08 – HIGH STATIC — 7.5 TON HORIZONTAL SUPPLY (RPM - VDC)

CFM	AVAILABLE EXTERNAL STATIC PRESSURE (in. wg)									
	0.2		0.4		0.6		0.8		1.0	
	rpm	Vdc	rpm	Vdc	rpm	Vdc	rpm	Vdc	rpm	Vdc
2250	910	4.0	1046	4.7	1167	5.2	1276	5.7	1376	6.2
2440	966	4.3	1095	4.9	1211	5.4	1316	5.9	1414	6.4
2625	1023	4.6	1145	5.1	1256	5.6	1359	6.1	1453	6.6
2810	1081	4.8	1197	5.4	1304	5.9	1403	6.3	1495	6.7
3000	1141	5.1	1251	5.6	1353	6.1	1449	6.5	1538	6.9
3190	1200	5.4	1306	5.9	1404	6.3	1496	6.8	1583	7.2
3375	1261	5.7	1361	6.1	1456	6.6	1545	7.0	1629	7.4
3560	1322	5.9	1418	6.4	1509	6.8	1595	7.2	1677	7.6
3750	1384	6.2	1476	6.7	1563	7.1	1646	7.4	1725	7.8

CFM	AVAILABLE EXTERNAL STATIC PRESSURE (in. wg)									
	1.2		1.4		1.6		1.8		2.0	
	rpm	Vdc	rpm	Vdc	rpm	Vdc	rpm	Vdc	rpm	Vdc
2250	1469	6.6	1556	7.0	1639	7.4	1716	7.8	1790	8.1
2440	1505	6.8	1590	7.2	1671	7.6	1748	7.9	1821	8.3
2625	1542	7.0	1626	7.4	1705	7.7	1781	8.1	1853	8.4
2810	1581	7.1	1663	7.5	1741	7.9	1816	8.2	1887	8.6
3000	1622	7.3	1702	7.7	1778	8.1	1852	8.4	1922	8.7
3190	1665	7.5	1743	7.9	1818	8.2	1889	8.6	1958	8.9
3375	1709	7.7	1785	8.1	1858	8.4	1928	8.7	1996	9.1
3560	1755	7.9	1829	8.3	1900	8.6	1969	8.9	2035	9.2
3750	1801	8.2	1874	8.5	1944	8.8	2011	9.1	2076	9.4

High Static 910-2200 rpm

## 50FC-M09 — 8.5 TON HORIZONTAL SUPPLY (RPM - BHP)

CFM	AVAILABLE EXTERNAL STATIC PRESSURE (in. wg)									
	0.2		0.4		0.6		0.8		1.0	
	rpm	bhp	rpm	bhp	rpm	bhp	rpm	bhp	rpm	bhp
2550	947	0.31	1065	0.45	1178	0.60	1284	0.78	1382	0.97
2760	1010	0.38	1120	0.51	1226	0.67	1327	0.85	1422	1.05
2975	1074	0.45	1177	0.59	1277	0.75	1373	0.94	1464	1.13
3190	1139	0.53	1235	0.67	1329	0.84	1421	1.02	1508	1.22
3400	1205	0.62	1296	0.77	1384	0.93	1471	1.12	1555	1.32
3610	1272	0.71	1357	0.86	1441	1.03	1524	1.22	1604	1.43
3825	1340	0.81	1420	0.97	1499	1.14	1578	1.33	1655	1.53
4040	1407	0.92	1484	1.08	1559	1.25	1634	1.44	1707	1.64
4250	1476	1.03	1548	1.19	1620	1.36	1691	1.55	1762	1.75

CFM	AVAILABLE EXTERNAL STATIC PRESSURE (in. wg)									
	1.2		1.4		1.6		1.8		2.0	
	rpm	bhp	rpm	bhp	rpm	bhp	rpm	bhp	rpm	bhp
2550	1473	1.18	1558	1.39	1638	1.62	1713	1.85	1785	2.10
2760	1511	1.26	1595	1.48	1674	1.71	1748	1.95	1819	2.20
2975	1551	1.35	1633	1.57	1710	1.81	1784	2.05	1855	2.31
3190	1592	1.44	1672	1.67	1749	1.91	1822	2.16	1891	2.41
3400	1636	1.54	1714	1.77	1789	2.01	1860	2.26	1929	2.52
3610	1682	1.64	1757	1.87	1830	2.12	1900	2.37	1968	2.63
3825	1730	1.75	1803	1.98	1873	2.22	1942	2.48	2008	2.74
4040	1779	1.86	1850	2.09	1918	2.33	1985	2.58	2050	2.84
4250	1831	1.97	1899	2.19	1965	2.43	2030	2.68	2093	2.94

Std/Med Static 947-2000 rpm, 2.4 Max bhp

High Static 947-2200 rpm, 3.0 Max bhp

## 50FC-M09 – STANDARD/MEDIUM STATIC — 8.5 TON HORIZONTAL SUPPLY (RPM - VDC)

CFM	AVAILABLE EXTERNAL STATIC PRESSURE (in. wg)									
	0.2		0.4		0.6		0.8		1.0	
	rpm	Vdc	rpm	Vdc	rpm	Vdc	rpm	Vdc	rpm	Vdc
2550	947	4.6	1065	5.2	1178	5.8	1284	6.3	1382	6.8
2760	1010	4.9	1120	5.5	1226	6.0	1327	6.5	1422	7.0
2975	1074	5.2	1177	5.8	1277	6.3	1373	6.8	1464	7.2
3190	1139	5.6	1235	6.1	1329	6.5	1421	7.0	1508	7.5
3400	1205	5.9	1296	6.4	1384	6.8	1471	7.3	1555	7.7
3610	1272	6.3	1357	6.7	1441	7.1	1524	7.6	1604	8.0
3825	1340	6.6	1420	7.0	1499	7.4	1578	7.8	1655	8.2
4040	1407	7.0	1484	7.3	1559	7.7	1634	8.1	1707	8.5
4250	1476	7.3	1548	7.7	1620	8.0	1691	8.4	1762	8.8

CFM	AVAILABLE EXTERNAL STATIC PRESSURE (in. wg)									
	1.2		1.4		1.6		1.8		2.0	
	rpm	Vdc	rpm	Vdc	rpm	Vdc	rpm	Vdc	rpm	Vdc
2550	1473	7.3	1558	7.7	1638	8.1	1713	8.5	1785	8.9
2760	1511	7.5	1595	7.9	1674	8.3	1748	8.7	1819	9.1
2975	1551	7.7	1633	8.1	1710	8.5	1784	8.9	1855	9.3
3190	1592	7.9	1672	8.3	1749	8.7	1822	9.1	—	—
3400	1636	8.1	1714	8.5	1789	8.9	1860	9.3	—	—
3610	1682	8.4	1757	8.8	1830	9.1	1900	9.5	—	—
3825	1730	8.6	1803	9.0	1873	9.3	—	—	—	—
4040	1779	8.9	1850	9.2	1918	9.6	—	—	—	—
4250	1831	9.1	1899	9.5	—	—	—	—	—	—

Std/Med Static 947-2000 rpm

## 50FC-M09 – HIGH STATIC — 8.5 TON HORIZONTAL SUPPLY (RPM - VDC)

CFM	AVAILABLE EXTERNAL STATIC PRESSURE (in. wg)									
	0.2		0.4		0.6		0.8		1.0	
	rpm	Vdc	rpm	Vdc	rpm	Vdc	rpm	Vdc	rpm	Vdc
2550	947	4.2	1065	4.8	1178	5.3	1284	5.8	1382	6.2
2760	1010	4.5	1120	5.0	1226	5.5	1327	6.0	1422	6.4
2975	1074	4.8	1177	5.3	1277	5.7	1373	6.2	1464	6.6
3190	1139	5.1	1235	5.5	1329	6.0	1421	6.4	1508	6.8
3400	1205	5.4	1296	5.8	1384	6.2	1471	6.6	1555	7.0
3610	1272	5.7	1357	6.1	1441	6.5	1524	6.9	1604	7.2
3825	1340	6.0	1420	6.4	1499	6.8	1578	7.1	1655	7.5
4040	1407	6.3	1484	6.7	1559	7.0	1634	7.4	1707	7.7
4250	1476	6.7	1548	7.0	1620	7.3	1691	7.7	1762	8.0

CFM	AVAILABLE EXTERNAL STATIC PRESSURE (in. wg)									
	1.2		1.4		1.6		1.8		2.0	
	rpm	Vdc	rpm	Vdc	rpm	Vdc	rpm	Vdc	rpm	Vdc
2550	1473	6.6	1558	7.0	1638	7.4	1713	7.8	1785	8.1
2760	1511	6.8	1595	7.2	1674	7.6	1748	7.9	1819	8.2
2975	1551	7.0	1633	7.4	1710	7.7	1784	8.1	1855	8.4
3190	1592	7.2	1672	7.6	1749	7.9	1822	8.3	1891	8.6
3400	1636	7.4	1714	7.8	1789	8.1	1860	8.4	1929	8.7
3610	1682	7.6	1757	8.0	1830	8.3	1900	8.6	1968	8.9
3825	1730	7.8	1803	8.2	1873	8.5	1942	8.8	2008	9.1
4040	1779	8.1	1850	8.4	1918	8.7	1985	9.0	2050	9.3
4250	1831	8.3	1899	8.6	1965	8.9	2030	9.2	2093	9.5

High Static 947-2200 rpm

## 50FC-M12 — 10 TON HORIZONTAL SUPPLY (RPM - BHP)

CFM	AVAILABLE EXTERNAL STATIC PRESSURE (in. wg)									
	0.2		0.4		0.6		0.8		1.0	
	rpm	bhp	rpm	bhp	rpm	bhp	rpm	bhp	rpm	bhp
3000	1100	0.49	1202	0.64	1301	0.81	1396	1.00	1487	1.21
3250	1176	0.59	1270	0.74	1363	0.92	1453	1.11	1539	1.32
3500	1252	0.70	1341	0.86	1428	1.04	1512	1.24	1595	1.45
3750	1330	0.83	1413	1.00	1495	1.18	1575	1.38	1653	1.60
4000	1409	0.97	1487	1.14	1563	1.33	1639	1.53	1714	1.75
4250	1488	1.12	1561	1.29	1634	1.48	1706	1.69	1776	1.90
4500	1568	1.28	1637	1.45	1706	1.65	1774	1.85	1841	2.07
4750	1648	1.44	1714	1.62	1779	1.81	1844	2.02	1908	2.23
5000	1728	1.61	1791	1.79	1853	1.98	1915	2.19	1976	2.40

CFM	AVAILABLE EXTERNAL STATIC PRESSURE (in. wg)									
	1.2		1.4		1.6		1.8		2.0	
	rpm	bhp	rpm	bhp	rpm	bhp	rpm	bhp	rpm	bhp
3000	1573	1.43	1654	1.66	1732	1.91	1805	2.16	1875	2.42
3250	1622	1.55	1702	1.79	1777	2.04	1849	2.29	1919	2.57
3500	1674	1.68	1751	1.92	1825	2.18	1895	2.44	1964	2.72
3750	1729	1.83	1803	2.07	1874	2.33	1943	2.59	2010	2.87
4000	1786	1.98	1857	2.22	1926	2.48	1993	2.75	2058	3.03
4250	1846	2.14	1914	2.38	1980	2.64	2045	2.91	2108	3.18
4500	1908	2.30	1973	2.54	2036	2.80	2099	3.06	2160	3.34
4750	1971	2.46	2034	2.71	2095	2.96	2155	3.22	—	—
5000	2036	2.63	2096	2.87	2155	3.11	—	—	—	—

Std/Med Static 1100-2000 rpm, 2.4 Max bhp

High Static 1100-2200 rpm, 5.0 Max bhp

## 50FC-M12 - STANDARD/MEDIUM STATIC — 10 TON HORIZONTAL SUPPLY (RPM - VDC)

CFM	AVAILABLE EXTERNAL STATIC PRESSURE (in. wg)									
	0.2		0.4		0.6		0.8		1.0	
	rpm	Vdc	rpm	Vdc	rpm	Vdc	rpm	Vdc	rpm	Vdc
3000	1100	5.4	1202	5.9	1301	6.4	1396	6.9	1487	7.4
3250	1176	5.8	1270	6.2	1363	6.7	1453	7.2	1539	7.6
3500	1252	6.2	1341	6.6	1428	7.1	1512	7.5	1595	7.9
3750	1330	6.6	1413	7.0	1495	7.4	1575	7.8	1653	8.2
4000	1409	7.0	1487	7.4	1563	7.8	1639	8.1	1714	8.5
4250	1488	7.4	1561	7.7	1634	8.1	1706	8.5	1776	8.8
4500	1568	7.8	1637	8.1	1706	8.5	1774	8.8	1841	9.2
4750	1648	8.2	1714	8.5	1779	8.9	1844	9.2	1908	9.5
5000	1728	8.6	1791	8.9	1853	9.2	1915	9.6	1976	9.9

CFM	AVAILABLE EXTERNAL STATIC PRESSURE (in. wg)									
	1.2		1.4		1.6		1.8		2.0	
	rpm	Vdc	rpm	Vdc	rpm	Vdc	rpm	Vdc	rpm	Vdc
3000	1573	7.8	1654	8.2	1732	8.6	1805	9.0	1875	9.4
3250	1622	8.1	1702	8.5	1777	8.9	1849	9.2	—	—
3500	1674	8.3	1751	8.7	1825	9.1	—	—	—	—
3750	1729	8.6	1803	9.0	1874	9.4	—	—	—	—
4000	1786	8.9	1857	9.3	—	—	—	—	—	—
4250	1846	9.2	1914	9.6	—	—	—	—	—	—
4500	1908	9.5	—	—	—	—	—	—	—	—
4750	—	—	—	—	—	—	—	—	—	—
5000	—	—	—	—	—	—	—	—	—	—

Std/Med Static 1100-2000 rpm



## 50FC-M12 – HIGH STATIC — 10 TON HORIZONTAL SUPPLY (RPM - VDC)

CFM	AVAILABLE EXTERNAL STATIC PRESSURE (in. wg)									
	0.2		0.4		0.6		0.8		1.0	
	rpm	Vdc	rpm	Vdc	rpm	Vdc	rpm	Vdc	rpm	Vdc
3000	1100	4.9	1202	5.4	1301	5.9	1396	6.3	1487	6.7
3250	1176	5.3	1270	5.7	1363	6.1	1453	6.6	1539	6.9
3500	1252	5.6	1341	6.0	1428	6.4	1512	6.8	1595	7.2
3750	1330	6.0	1413	6.4	1495	6.7	1575	7.1	1653	7.5
4000	1409	6.3	1487	6.7	1563	7.1	1639	7.4	1714	7.8
4250	1488	6.7	1561	7.1	1634	7.4	1706	7.7	1776	8.0
4500	1568	7.1	1637	7.4	1706	7.7	1774	8.0	1841	8.3
4750	1648	7.5	1714	7.8	1779	8.1	1844	8.4	1908	8.7
5000	1728	7.8	1791	8.1	1853	8.4	1915	8.7	1976	9.0

CFM	AVAILABLE EXTERNAL STATIC PRESSURE (in. wg)									
	1.2		1.4		1.6		1.8		2.0	
	rpm	Vdc	rpm	Vdc	rpm	Vdc	rpm	Vdc	rpm	Vdc
3000	1573	7.1	1654	7.5	1732	7.8	1805	8.2	1875	8.5
3250	1622	7.3	1702	7.7	1777	8.0	1849	8.4	1919	8.7
3500	1674	7.6	1751	7.9	1825	8.3	1895	8.6	1964	8.9
3750	1729	7.8	1803	8.2	1874	8.5	1943	8.8	2010	9.1
4000	1786	8.1	1857	8.4	1926	8.7	1993	9.0	2058	9.3
4250	1846	8.4	1914	8.7	1980	9.0	2045	9.3	2108	9.6
4500	1908	8.7	1973	9.0	2036	9.2	2099	9.5	2160	9.8
4750	1971	8.9	2034	9.2	2095	9.5	2155	9.8	—	—
5000	2036	9.2	2096	9.5	2155	9.8	—	—	—	—

High Static 1100-2200 rpm

## 50FC-M14 — 12.5 TON HORIZONTAL SUPPLY (RPM - BHP)

CFM	AVAILABLE EXTERNAL STATIC PRESSURE (in. wg)									
	0.2		0.4		0.6		0.8		1.0	
	rpm	bhp	rpm	bhp	rpm	bhp	rpm	bhp	rpm	bhp
3750	1072	0.65	1166	0.83	1266	1.07	1363	1.33	1454	1.62
4060	1148	0.79	1233	0.98	1324	1.22	1416	1.49	1504	1.78
4375	1226	0.96	1303	1.15	1386	1.39	1472	1.66	1556	1.97
4690	1304	1.15	1374	1.35	1451	1.59	1530	1.86	1610	2.17
5000	1383	1.37	1448	1.57	1518	1.81	1592	2.08	1667	2.39
5310	1463	1.60	1523	1.81	1588	2.05	1656	2.33	1726	2.63
5625	1543	1.86	1599	2.07	1659	2.31	1723	2.59	1789	2.90
5940	1623	2.14	1675	2.35	1732	2.60	1791	2.87	1853	3.18
6250	1704	2.44	1753	2.65	1806	2.90	1861	3.17	1919	3.48

CFM	AVAILABLE EXTERNAL STATIC PRESSURE (in. wg)									
	1.2		1.4		1.6		1.8		2.0	
	rpm	bhp	rpm	bhp	rpm	bhp	rpm	bhp	rpm	bhp
3750	1540	1.92	1620	2.24	1694	2.56	1765	2.89	1833	3.24
4060	1587	2.09	1666	2.42	1740	2.76	1810	3.11	1877	3.46
4375	1637	2.29	1713	2.62	1786	2.97	1856	3.34	1922	3.71
4690	1688	2.50	1763	2.85	1834	3.20	1902	3.57	1968	3.96
5000	1741	2.72	1813	3.08	1883	3.45	1950	3.83	2015	4.22
5310	1797	2.97	1867	3.33	1934	3.70	2000	4.10	2063	4.50
5625	1855	3.23	1922	3.60	1987	3.97	2050	4.36	2112	4.77
5940	1915	3.51	1979	3.88	2042	4.26	2103	4.65	2163	5.06
6250	1978	3.81	2038	4.17	2098	4.55	2158	4.95	—	—

Std/Med Static 1072-2200 rpm, 3.0 Max bhp

High Static 1072-2200 rpm, 5.0 Max bhp

## 50FC-M14 – STANDARD/MEDIUM STATIC — 12.5 TON HORIZONTAL SUPPLY (RPM - VDC)

CFM	AVAILABLE EXTERNAL STATIC PRESSURE (in. wg)									
	0.2		0.4		0.6		0.8		1.0	
	rpm	Vdc	rpm	Vdc	rpm	Vdc	rpm	Vdc	rpm	Vdc
3750	1072	4.8	1166	5.2	1266	5.7	1363	6.1	1454	6.6
4060	1148	5.1	1233	5.5	1324	6.0	1416	6.4	1504	6.8
4375	1226	5.5	1303	5.9	1386	6.2	1472	6.6	1556	7.0
4690	1304	5.9	1374	6.2	1451	6.5	1530	6.9	1610	7.3
5000	1383	6.2	1448	6.5	1518	6.9	1592	7.2	1667	7.5
5310	1463	6.6	1523	6.9	1588	7.2	1656	7.5	1726	7.8
5625	1543	7.0	1599	7.2	1659	7.5	1723	7.8	1789	8.1
5940	1623	7.3	1675	7.6	1732	7.8	1791	8.1	—	—
6250	1704	7.7	1753	7.9	1806	8.2	—	—	—	—

CFM	AVAILABLE EXTERNAL STATIC PRESSURE (in. wg)									
	1.2		1.4		1.6		1.8		2.0	
	rpm	Vdc	rpm	Vdc	rpm	Vdc	rpm	Vdc	rpm	Vdc
3750	1540	7.0	1620	7.3	1694	7.7	1765	8.0	—	—
4060	1587	7.2	1666	7.5	1740	7.9	—	—	—	—
4375	1637	7.4	1713	7.8	1786	8.1	—	—	—	—
4690	1688	7.6	1763	8.0	—	—	—	—	—	—
5000	1741	7.9	—	—	—	—	—	—	—	—
5310	1797	8.1	—	—	—	—	—	—	—	—
5625	—	—	—	—	—	—	—	—	—	—
5940	—	—	—	—	—	—	—	—	—	—
6250	—	—	—	—	—	—	—	—	—	—

Std/Med Static 1072-2200 rpm

## 50FC-M14 – HIGH STATIC – 12.5 TON HORIZONTAL SUPPLY (RPM - VDC)

CFM	AVAILABLE EXTERNAL STATIC PRESSURE (in. wg)									
	0.2		0.4		0.6		0.8		1.0	
	rpm	Vdc	rpm	Vdc	rpm	Vdc	rpm	Vdc	rpm	Vdc
3750	1072	4.8	1166	5.2	1266	5.7	1363	6.1	1454	6.6
4060	1148	5.1	1233	5.5	1324	6.0	1416	6.4	1504	6.8
4375	1226	5.5	1303	5.9	1386	6.2	1472	6.6	1556	7.0
4690	1304	5.9	1374	6.2	1451	6.5	1530	6.9	1610	7.3
5000	1383	6.2	1448	6.5	1518	6.9	1592	7.2	1667	7.5
5310	1463	6.6	1523	6.9	1588	7.2	1656	7.5	1726	7.8
5625	1543	7.0	1599	7.2	1659	7.5	1723	7.8	1789	8.1
5940	1623	7.3	1675	7.6	1732	7.8	1791	8.1	1853	8.4
6250	1704	7.7	1753	7.9	1806	8.2	1861	8.4	1919	8.7

CFM	AVAILABLE EXTERNAL STATIC PRESSURE (in. wg)									
	1.2		1.4		1.6		1.8		2.0	
	rpm	Vdc	rpm	Vdc	rpm	Vdc	rpm	Vdc	rpm	Vdc
3750	1540	7.0	1620	7.3	1694	7.7	1765	8.0	1833	8.3
4060	1587	7.2	1666	7.5	1740	7.9	1810	8.2	1877	8.5
4375	1637	7.4	1713	7.8	1786	8.1	1856	8.4	1922	8.7
4690	1688	7.6	1763	8.0	1834	8.3	1902	8.6	1968	8.9
5000	1741	7.9	1813	8.2	1883	8.5	1950	8.8	2015	9.1
5310	1797	8.1	1867	8.5	1934	8.8	2000	9.1	2063	9.4
5625	1855	8.4	1922	8.7	1987	9.0	2050	9.3	2112	9.6
5940	1915	8.7	1979	9.0	2042	9.3	2103	9.6	2163	9.8
6250	1978	9.0	2038	9.3	2098	9.5	2158	9.8	—	—

High Static 1072-2200 rpm

## 50FC-M16 — 15 TON HORIZONTAL SUPPLY (RPM - BHP)

CFM	AVAILABLE EXTERNAL STATIC PRESSURE (in. wg)									
	0.2		0.4		0.6		0.8		1.0	
	rpm	bhp	rpm	bhp	rpm	bhp	rpm	bhp	rpm	bhp
4500	1117	0.73	1198	0.90	1278	1.09	1358	1.31	1438	1.55
4875	1205	0.91	1279	1.09	1353	1.29	1427	1.51	1501	1.76
5250	1294	1.12	1363	1.30	1432	1.51	1500	1.74	1569	1.99
5625	1383	1.34	1448	1.54	1512	1.76	1576	1.99	1640	2.24
6000	1473	1.60	1534	1.80	1594	2.02	1654	2.26	1714	2.52
6375	1564	1.88	1621	2.09	1678	2.32	1734	2.56	1791	2.82
6750	1655	2.18	1709	2.40	1762	2.63	1816	2.88	1869	3.14
7125	1746	2.54	1797	2.76	1848	3.01	1899	3.26	1949	3.53
7500	1838	2.97	1886	3.21	1935	3.46	1983	3.73	2031	4.00

CFM	AVAILABLE EXTERNAL STATIC PRESSURE (in. wg)									
	1.2		1.4		1.6		1.8		2.0	
	rpm	bhp	rpm	bhp	rpm	bhp	rpm	bhp	rpm	bhp
4500	1516	1.82	1594	2.12	1670	2.43	1744	2.77	1816	3.13
4875	1575	2.03	1647	2.32	1719	2.64	1790	2.98	1858	3.33
5250	1638	2.26	1706	2.56	1773	2.87	1840	3.21	1905	3.56
5625	1704	2.51	1768	2.81	1832	3.12	1895	3.46	1957	3.81
6000	1775	2.79	1835	3.09	1894	3.39	1954	3.73	2013	4.08
6375	1848	3.09	1904	3.38	1961	3.70	2017	4.02	2073	4.37
6750	1923	3.43	1976	3.72	2030	4.03	2083	4.35	2136	4.69
7125	2000	3.81	2051	4.11	2101	4.42	2152	4.75	—	—
7500	2079	4.29	2127	4.60	2175	4.92	—	—	—	—

Std/Med Static 1117-2200 rpm, 3.0 Max bhp

High Static 1117-2200 rpm, 5.0 Max bhp

## 50FC-M16 - STANDARD/MEDIUM STATIC — 15 TON HORIZONTAL SUPPLY (RPM - VDC)

CFM	AVAILABLE EXTERNAL STATIC PRESSURE (in. wg)									
	0.2		0.4		0.6		0.8		1.0	
	rpm	Vdc	rpm	Vdc	rpm	Vdc	rpm	Vdc	rpm	Vdc
4500	1117	5.0	1198	5.4	1278	5.7	1358	6.1	1438	6.5
4875	1205	5.4	1279	5.7	1353	6.1	1427	6.4	1501	6.8
5250	1294	5.8	1363	6.1	1432	6.5	1500	6.8	1569	7.1
5625	1383	6.2	1448	6.5	1512	6.8	1576	7.1	1640	7.4
6000	1473	6.6	1534	6.9	1594	7.2	1654	7.5	1714	7.8
6375	1564	7.1	1621	7.3	1678	7.6	1734	7.8	1791	8.1
6750	1655	7.5	1709	7.7	1762	8.0	1816	8.2	1869	8.5
7125	1746	7.9	1797	8.1	1848	8.4	—	—	—	—
7500	1838	8.3	—	—	—	—	—	—	—	—

CFM	AVAILABLE EXTERNAL STATIC PRESSURE (in. wg)									
	1.2		1.4		1.6		1.8		2.0	
	rpm	Vdc	rpm	Vdc	rpm	Vdc	rpm	Vdc	rpm	Vdc
4500	1516	6.8	1594	7.2	1670	7.6	1744	7.9	—	—
4875	1575	7.1	1647	7.4	1719	7.8	1790	8.1	—	—
5250	1638	7.4	1706	7.7	1773	8.0	—	—	—	—
5625	1704	7.7	1768	8.0	—	—	—	—	—	—
6000	1775	8.0	—	—	—	—	—	—	—	—
6375	—	—	—	—	—	—	—	—	—	—
6750	—	—	—	—	—	—	—	—	—	—
7125	—	—	—	—	—	—	—	—	—	—
7500	—	—	—	—	—	—	—	—	—	—

Std/Med Static 1117-2200 rpm

## 50FC-M16 – HIGH STATIC — 15 TON HORIZONTAL SUPPLY (RPM - VDC)

CFM	AVAILABLE EXTERNAL STATIC PRESSURE (in. wg)									
	0.2		0.4		0.6		0.8		1.0	
	rpm	Vdc	rpm	Vdc	rpm	Vdc	rpm	Vdc	rpm	Vdc
4500	1117	5.0	1198	5.4	1278	5.7	1358	6.1	1438	6.5
4875	1205	5.4	1279	5.7	1353	6.1	1427	6.4	1501	6.8
5250	1294	5.8	1363	6.1	1432	6.5	1500	6.8	1569	7.1
5625	1383	6.2	1448	6.5	1512	6.8	1576	7.1	1640	7.4
6000	1473	6.6	1534	6.9	1594	7.2	1654	7.5	1714	7.8
6375	1564	7.1	1621	7.3	1678	7.6	1734	7.8	1791	8.1
6750	1655	7.5	1709	7.7	1762	8.0	1816	8.2	1869	8.5
7125	1746	7.9	1797	8.1	1848	8.4	1899	8.6	1949	8.8
7500	1838	8.3	1886	8.6	1935	8.8	1983	9.0	2031	9.2

CFM	AVAILABLE EXTERNAL STATIC PRESSURE (in. wg)									
	1.2		1.4		1.6		1.8		2.0	
	rpm	Vdc	rpm	Vdc	rpm	Vdc	rpm	Vdc	rpm	Vdc
4500	1516	6.8	1594	7.2	1670	7.6	1744	7.9	1816	8.2
4875	1575	7.1	1647	7.4	1719	7.8	1790	8.1	1858	8.4
5250	1638	7.4	1706	7.7	1773	8.0	1840	8.3	1905	8.6
5625	1704	7.7	1768	8.0	1832	8.3	1895	8.6	1957	8.9
6000	1775	8.0	1835	8.3	1894	8.6	1954	8.9	2013	9.1
6375	1848	8.4	1904	8.6	1961	8.9	2017	9.2	2073	9.4
6750	1923	8.7	1976	9.0	2030	9.2	2083	9.5	2136	9.7
7125	2000	9.1	2051	9.3	2101	9.5	2152	9.8	—	—
7500	2079	9.4	2127	9.7	2175	9.9	—	—	—	—

High Static 1117-2200 rpm

## Legend and Notes

### Applicable for Electrical Data Tables on pages 103 to 130

#### LEGEND

<b>BRKR</b>	— Circuit Breaker
<b>C.O.</b>	— Convenience Outlet
<b>FLA</b>	— Full Load Amps
<b>IFM</b>	— Indoor Fan Motor
<b>LRA</b>	— Locked Rotor Amps
<b>MCA</b>	— Minimum Circuit Amps
<b>P.E.</b>	— Power Exhaust
<b>PWRD C.O.</b>	— Powered Convenience Outlet
<b>RLA</b>	— Rated Load Amps
<b>SCCR</b>	— Short Circuit Current Rating
<b>UNPWR C.O.</b>	— Unpowered Convenience Outlet

#### NOTES:

1. In compliance with NEC requirements for multi-motor and combination load equipment (refer to NEC Articles 430 and 440), the overcurrent protective device for the unit shall be fuse or HACR breaker. Canadian units may be fuse or circuit breaker.
2. For 208/230 v units, where one value is show it is the same for either 208 or 230 volts.
3. **Unbalanced 3-Phase Supply Voltage**  
Never operate a motor where a phase imbalance in supply voltage is greater than 2%. Use the following formula to determine the percentage of voltage imbalance.

$$\% \text{ Voltage Imbalance} = 100 \times \frac{\text{max voltage deviation from average voltage}}{\text{average voltage}}$$

Example: Supply voltage is 230-3-60

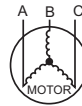

AB = 224 v

BC = 231 v

AC = 226 v

$$\text{Average Voltage} = \frac{(224 + 231 + 226)}{3} = \frac{681}{3} = 227$$

Determine maximum deviation from average voltage.

(AB) 227-224 = 3 v

(BC) 231-227 = 4 v

(AC) 227-226 = 1 v

Maximum deviation is 4 v.

Determine percent of voltage imbalance.

$$\% \text{ Voltage Imbalance} = 100 \times \frac{4}{227} = 1.78\%$$

This amount of phase imbalance is satisfactory as it is below the maximum allowable 2%.

**IMPORTANT:** If the supply voltage phase imbalance is more than 2%, contact your local electric utility company immediately.

## 48/50FC\*\*08-16 COOLING ELECTRICAL DATA

48/50FC UNIT SIZE	V-Ph-Hz	UNIT VOLTAGE		COMP 1		COMP 2		OFM (EA)		STD SCCR kA	HIGH SCCR kA	IFM			COMBUSTION FAN MOTOR (48 SERIES ONLY)	POWER EXHAUST		
		RANGE		RLA	LRA	RLA	LRA	WATTS	FLA			TYPE	EFFCY AT FULL LOAD	FLA		FLA	KIT QTY	FLA (EA KIT)
		MIN	MAX															
08	208-3-60	187	253	13.1	123	13.1	123	325	1.5	5	10	STD/MED HIGH	90%	6.4 7.5	0.48	1	3.8	
	230-3-60	187	253	13.1	123	13.1	123	325	1.5	5	10	STD/MED HIGH	90%	6.4 7.5	0.48	1	3.8	
	460-3-60	414	506	6.1	60	6.1	60	325	0.8	5	10	STD/MED HIGH	90%	3.0 3.5	0.25	1	1.8	
	575-3-60	518	633	4.6	41	4.6	41	325	0.6	5	—	STD/MED HIGH	90%	2.5 3.0	0.24	1	3.8	
09	208-3-60	187	253	13.7	123	13.7	123	325	1.5	5	10	STD/MED HIGH	90%	6.4 7.5	0.48	1	3.8	
	230-3-60	187	253	13.7	123	13.7	123	325	1.5	5	10	STD/MED HIGH	90%	6.4 7.5	0.48	1	3.8	
	460-3-60	414	506	6.2	60	6.2	60	325	0.8	5	10	STD/MED HIGH	90%	3.0 3.5	0.25	1	1.8	
	575-3-60	518	633	4.8	41	4.8	41	325	0.6	5	—	STD/MED HIGH	90%	2.5 3.0	0.24	1	3.8	
12	208-3-60	187	253	15.6	110	15.6	110	325	1.5	5	10	STD/MED HIGH	90%	6.4 12.6	0.48	1	3.8	
	230-3-60	187	253	15.6	110	15.6	110	325	1.5	5	10	STD/MED HIGH	90%	6.4 12.6	0.48	1	3.8	
	460-3-60	414	506	7.7	60	7.7	60	325	0.8	5	10	STD/MED HIGH	90%	3.0 5.6	0.25	1	1.8	
	575-3-60	518	633	5.9	41	5.9	41	325	0.6	5	—	STD/MED HIGH	90%	2.5 4.6	0.24	1	3.8	
14	208-3-60	187	253	22.4	149	19.6	136	1070	7.4	5	10	STD/MED HIGH	90%	7.5 12.6	0.48	1	3.8	
	230-3-60	187	253	22.4	149	19.6	136	1070	7.4	5	10	STD/MED HIGH	90%	7.5 12.6	0.48	1	3.8	
	460-3-60	414	506	10.6	75	8.2	66	1070	7.4	5	10	STD/MED HIGH	90%	3.5 5.6	0.25	1	1.8	
	575-3-60	518	633	7.7	54	6.6	55	1070	7.4	5	—	STD/MED HIGH	90%	3.0 4.6	0.24	1	3.8	
16	208-3-60	187	253	28.2	239	19.6	136	280	1.5	5	10	STD/MED HIGH	90%	7.5 12.6	0.48	1	3.8	
	230-3-60	187	253	28.2	239	19.6	136	280	1.5	5	10	STD/MED HIGH	90%	7.5 12.6	0.48	1	3.8	
	460-3-60	414	506	14.7	130	8.2	66	280	0.8	5	10	STD/MED HIGH	90%	3.5 5.6	0.25	1	1.8	
	575-3-60	518	633	11.3	94	6.6	55	280	0.6	5	—	STD/MED HIGH	90%	3.0 4.6	0.24	1	3.8	

## 48FC\*\*08-16 MCA MOCP ELECTRICAL DATA

48FC UNIT SIZE	NOM. V-Ph-Hz	IFM TYPE	STD SCCR kA	HIGH SCCR kA <sup>a</sup>	NO CONVENIENCE OUTLET OR UNPOWERED CONVENIENCE OUTLET							
					NO POWER EXHAUST				w/ POWER EXHAUST (powered from unit)			
					MCA	FUSE OR HACR BREAKER	DISCONNECT SIZE		MCA	FUSE OR HACR BREAKER	DISCONNECT SIZE	
							FLA	LRA			FLA	LRA
48FC**08	208/230-3-60	STD/MED	5	10	39	50	41	263	43	50	45	267
		HIGH	5	10	40	50	42	265	44	50	47	269
	460-3-60	STD/MED	5	10	19	20	19	128	21	25	21	130
		HIGH	5	10	19	25	20	131	21	25	22	133
	575-3-60	STD/MED	5	—	15	20	15	90	18	20	19	94
		HIGH	5	—	15	20	15	91	19	20	20	95
48FC**09	208/230-3-60	STD/MED	5	10	41	50	42	263	44	50	47	267
		HIGH	5	10	42	50	44	265	46	50	48	269
	460-3-60	STD/MED	5	10	19	25	20	128	21	25	22	130
		HIGH	5	10	20	25	20	131	21	25	22	133
	575-3-60	STD/MED	5	—	15	20	15	90	19	20	20	94
		HIGH	5	—	15	20	16	91	19	25	20	95
48FC**12	208/230-3-60	STD/MED	5	10	45	60	47	237	49	60	51	241
		HIGH	5	10	51	60	54	246	55	60	58	250
	460-3-60	STD/MED	5	10	22	25	23	128	24	30	25	130
		HIGH	5	10	25	30	26	132	27	30	28	134
	575-3-60	STD/MED	5	—	17	20	18	90	21	25	22	94
		HIGH	5	—	20	25	20	92	23	25	25	96
48FC**14	208/230-3-60	STD/MED	5	10	63	80	65	303	67	80	70	307
		HIGH	5	10	68	80	71	310	72	80	76	314
	460-3-60	STD/MED	5	10	33	40	34	155	35	40	36	157
		HIGH	5	10	35	45	37	156	37	45	39	158
	575-3-60	STD/MED	5	—	27	30	28	121	31	35	33	125
		HIGH	5	—	29	35	30	122	32	35	35	126
48FC**16	208/230-3-60	STD/MED	5	10	67	80	69	398	71	80	73	402
		HIGH	5	10	72	80	75	405	76	100	79	409
	460-3-60	STD/MED	5	10	33	45	33	209	35	45	35	211
		HIGH	5	10	35	45	36	210	37	50	38	212
	575-3-60	STD/MED	5	—	26	30	26	160	30	40	30	164
		HIGH	5	—	28	30	28	161	31	40	32	165

NOTE(S):

- a. High SCCR (Short Circuit Current Rating) is not available on the following: units with Humidi-MiZer system, Low Ambient controls, Phase loss monitor, Non-fused disconnect, and 575V.



## 48FC\*\*08-16 MCA MOCP ELECTRICAL DATA (CONT)

48FC UNIT SIZE	NOM. V-Ph-Hz	IFM TYPE	STD SCCR kA	w/ POWERED CONVENIENCE OUTLET							
				NO POWER EXHAUST				w/ POWER EXHAUST (powered from unit)			
				MCA	FUSE OR HACR BREAKER	DISCONNECT SIZE		MCA	FUSE OR HACR BREAKER	DISCONNECT SIZE	
						FLA	LRA			FLA	LRA
48FC**08	208/230-3-60	STD/MED	5	44	50	46	268	48	60	51	272
		HIGH	5	45	50	48	270	49	60	52	274
	460-3-60	STD/MED	5	21	25	22	130	23	25	24	132
		HIGH	5	21	25	22	133	23	25	24	135
	575-3-60	STD/MED	5	16	20	17	92	20	25	21	96
		HIGH	5	17	20	17	93	21	25	22	97
48FC**09	208/230-3-60	STD/MED	5	45	50	48	268	49	60	52	272
		HIGH	5	47	50	49	270	50	60	53	274
	460-3-60	STD/MED	5	21	25	22	130	23	25	24	132
		HIGH	5	22	25	23	133	24	25	25	135
	575-3-60	STD/MED	5	17	20	17	92	20	25	22	96
		HIGH	5	17	20	18	93	21	25	22	97
48FC**12	208/230-3-60	STD/MED	5	50	60	52	242	54	60	57	246
		HIGH	5	56	60	59	251	60	70	64	255
	460-3-60	STD/MED	5	25	30	26	130	26	30	28	132
		HIGH	5	27	30	29	134	29	35	31	136
	575-3-60	STD/MED	5	19	25	20	92	23	25	24	96
		HIGH	5	21	25	22	94	25	30	27	98
48FC**14	208/230-3-60	STD/MED	5	68	80	71	308	72	80	75	312
		HIGH	5	73	80	77	315	—	—	—	—
	460-3-60	STD/MED	5	35	45	37	157	37	45	39	159
		HIGH	5	37	45	39	158	39	45	41	160
	575-3-60	STD/MED	5	29	35	30	123	33	35	35	127
		HIGH	5	30	35	74	403	76	100	79	407
48FC**16	208/230-3-60	STD/MED	5	72	80	80	410	81	100	85	414
		HIGH	5	77	100	36	211	37	50	38	213
	460-3-60	STD/MED	5	35	45	38	212	39	50	40	214
		HIGH	5	37	50	28	162	31	40	32	166
	575-3-60	STD/MED	5	28	35	30	163	33	40	34	167
		HIGH	5	29	40	74	403	76	100	79	407

## 50FC\*\*08 MCA MOCP ELECTRICAL DATA

50FC UNIT SIZE	NOM. V-Ph-Hz	IFM TYPE	STD SCCR KA	HIGH SCCR KA <sup>a</sup>	ELECTRIC HEATER			NO CONVENIENCE OUTLET or UNPOWERED CONVENIENCE OUTLET							
					CRHEATER ****00	NOM (kW)	FLA	NO POWER EXHAUST				w/ POWER EXHAUST (powered from unit)			
								MCA	FUSE OR HACR BRKR	DISCONNECT SIZE		MCA	FUSE OR HACR BRKR	DISCONNECT SIZE	
										FLA	LRA			FLA	LRA
50FC**08	208/230-3-60	STD/MED	5	10	—	—	—	39	50	41	263	43	50	45	267
					411A	7.8/10.4	21.7/25.0	39/40	50/50	41/41	263/263	43/44	50/50	45/45	267/267
					412A	12.0/16.0	33.4/38.5	50/57	50/60	46/52	263/263	55/61	60/70	50/56	267/267
					414A	18.8/25.0	52.1/60.1	74/84	80/90	67/76	263/263	78/88	80/90	72/81	267/267
					415A	24.0/32.0	66.7/77.0	92/105	100/110	84/96	263/263	97/109	100/110	88/100	267/267
		416A	31.8/42.4	88.4/102.0	119/136	125/150	109/125	263/263	124/141	125/150	113/129	267/267			
		HIGH	5	10	—	—	—	40	50	42	265	44	50	47	269
					411A	7.8/10.4	21.7/25.0	40/41	50/50	42/42	265/265	44/46	50/50	47/47	269/269
					412A	12.0/16.0	33.4/38.5	52/58	60/60	47/53	265/265	56/63	60/70	51/57	269/269
					414A	18.8/25.0	52.1/60.1	75/85	80/90	69/78	265/265	80/90	80/90	73/82	269/269
	415A				24.0/32.0	66.7/77.0	93/106	100/110	85/97	265/265	98/111	100/125	90/102	269/269	
	416A	31.8/42.4	88.4/102.0	120/137	125/150	110/126	265/265	125/142	125/150	115/130	269/269				
	460-3-60	STD/MED	5	10	—	—	—	19	20	19	128	21	25	21	130
					420A	15.0	18.0	27	30	24	128	29	30	26	130
					421A	25.0	30.1	42	45	38	128	44	45	40	130
					422A	33.0	39.7	54	60	49	128	56	60	51	130
					423A	41.7	50.2	67	70	61	128	69	70	63	130
		HIGH	5	10	—	—	—	19	25	20	131	21	25	22	133
					420A	15.0	18.0	27	30	25	131	30	30	27	133
					421A	25.0	30.1	42	45	39	131	45	45	41	133
422A					33.0	39.7	54	60	50	131	57	60	52	133	
423A					41.7	50.2	68	70	62	131	70	70	64	133	
575-3-60	STD/MED	5	—	—	—	—	15	20	15	90	18	20	19	94	
				425A	18.0	17.3	25	25	23	90	30	30	27	94	
				427A	36.0	34.6	47	50	43	90	52	60	47	94	
	HIGH	5	—	—	—	—	15	20	15	91	19	20	20	95	
				425A	18.0	17.3	26	30	23	91	31	35	28	95	
				427A	36.0	34.6	47	50	43	91	52	60	48	95	

NOTE(S):

- a. High SCCR (Short Circuit Current Rating) is not available on the following: units with Humidi-MiZer system, Low Ambient controls, Phase loss monitor, Non-fused disconnect, and 575V.

## 50FC\*\*08 MCA MOCP ELECTRICAL DATA (cont)

50FC UNIT SIZE	NOM. V-Ph-Hz	IFM TYPE	STD SCCR kA	ELECTRIC HEATER			w/ POWERED CONVENIENCE OUTLET								
				CRHEATER ****00	NOM (kW)	FLA	NO POWER EXHAUST				w/ POWER EXHAUST (powered from unit)				
							MCA	FUSE OR HACR BRKR	DISCONNECT SIZE		MCA	FUSE OR HACR BRKR	DISCONNECT SIZE		
									FLA	LRA			FLA	LRA	
50FC**08	208/230-3-60	STD/MED	5	—	—	—	44	50	46	268	48	60	51	272	
				411A	7.8/10.4	21.7/25.0	44/46	50/50	46/46	268/268	48/50	60/60	51/51	272/272	
				412A	12.0/16.0	33.4/38.5	56/63	60/70	51/57	268/268	61/67	70/70	56/62	272/272	
				414A	18.8/25.0	52.1/60.1	—	80/90	73/82	268/268	84/94	90/100	77/86	272/272	
				415A	24.0/32.0	66.7/77.0	98/111	100/125	90/101	268/268	103/115	110/125	94/106	272/272	
				416A	31.8/42.4	88.4/102.0	125/142	125/150	115/130	268/268	130/147	150/150	119/135	272/272	
		HIGH	5	—	—	—	45	50	48	270	49	60	52	274	
				411A	7.8/10.4	21.7/25.0	45/47	50/50	48/48	270/270	49/52	60/60	52/52	274/274	
				412A	12.0/16.0	33.4/38.5	58/64	60/70	53/58	270/270	62/69	70/70	57/63	274/274	
				414A	18.8/25.0	52.1/60.1	81/91	90/100	74/83	270/270	86/96	90/100	78/88	274/274	
				415A	24.0/32.0	66.7/77.0	99/112	100/125	91/103	270/270	104/117	110/125	95/107	274/274	
				416A	31.8/42.4	88.4/102.0	126/143	150/150	116/131	270/270	131/148	150/150	120/136	274/274	
	460-3-60	STD/MED	5	—	—	—	21	25	22	130	23	25	24	132	
				420A	15.0	18.0	29	30	27	130	32	35	29	132	
				421A	25.0	30.1	45	45	41	130	47	50	43	132	
				422A	33.0	39.7	57	60	52	130	59	60	54	132	
				423A	41.7	50.2	70	70	64	130	72	80	66	132	
				HIGH	5	—	—	—	21	25	22	133	23	25	24
		420A	15.0			18.0	30	30	27	133	32	35	29	135	
		421A	25.0			30.1	45	45	41	133	47	50	43	135	
		422A	33.0			39.7	57	60	52	133	59	60	54	135	
		423A	41.7			50.2	70	70	64	133	73	80	66	135	
		575-3-60	STD/MED			5	—	—	—	16	20	17	92	20	25
				425A	18.0		17.3	27	30	25	92	32	35	29	96
427A	36.0			34.6	49		50	45	92	54	60	49	96		
HIGH	5		—	—	—	17	20	17	93	21	25	22	97		
			425A	18.0	17.3	28	30	25	93	33	35	30	97		
			427A	36.0	34.6	50	50	45	93	54	60	50	97		

## 50FC\*\*09 MCA MOCP ELECTRICAL DATA

50FC UNIT SIZE	NOM. V-Ph-Hz	IFM TYPE	STD SCCR KA	HIGH SCCR KA <sup>a</sup>	ELECTRIC HEATER			NO CONVENIENCE OUTLET or UNPOWERED CONVENIENCE OUTLET							
					CRHEATER ****00	NOM (kW)	FLA	NO POWER EXHAUST				w/ POWER EXHAUST (powered from unit)			
								MCA	FUSE OR HACR BRKR	DISCONNECT SIZE		MCA	FUSE OR HACR BRKR	DISCONNECT SIZE	
										FLA	LRA			FLA	LRA
50FC**09	208/230-3-60	STD/MED	5	10	—	—	—	41	50	42	263	44	50	47	267
					411A	7.8/10.4	21.7/25.0	41/41	50/50	42/42	263/263	44/44	50/50	47/47	267/267
					412A	12.0/16.0	33.4/38.5	50/57	50/60	46/52	263/263	55/61	60/70	50/56	267/267
					414A	18.8/25.0	52.1/60.1	74/84	80/90	67/76	263/263	78/88	80/90	72/81	267/267
					415A	24.0/32.0	66.7/77.0	92/105	100/110	84/96	263/263	97/109	100/110	88/100	267/267
		416A	31.8/42.4	88.4/102.0	119/136	125/150	109/125	263/263	124/141	125/150	113/129	267/267			
		HIGH	5	10	—	—	—	42	50	44	265	46	50	48	269
					411A	7.8/10.4	21.7/25.0	42/42	50/50	44/44	265/265	46/46	50/50	48/48	269/269
					412A	12.0/16.0	33.4/38.5	52/58	60/60	47/53	265/265	56/63	60/70	51/57	269/269
					414A	18.8/25.0	52.1/60.1	75/85	80/90	69/78	265/265	80/90	80/90	73/82	269/269
	415A				24.0/32.0	66.7/77.0	93/106	100/110	85/97	265/265	98/111	100/125	90/102	269/269	
	416A	31.8/42.4	88.4/102.0	120/137	125/150	110/126	265/265	125/142	125/150	115/130	269/269				
	460-3-60	STD/MED	5	10	—	—	—	19	25	20	128	21	25	22	130
					420A	15.0	18.0	27	30	24	128	29	30	26	130
					421A	25.0	30.1	42	45	38	128	44	45	40	130
					422A	33.0	39.7	54	60	49	128	56	60	51	130
					423A	41.7	50.2	67	70	61	128	69	70	63	130
		HIGH	5	10	—	—	—	20	25	20	131	21	25	22	133
					420A	15.0	18.0	27	30	25	131	30	30	27	133
					421A	25.0	30.1	42	45	39	131	45	45	41	133
422A					33.0	39.7	54	60	50	131	57	60	52	133	
423A					41.7	50.2	68	70	62	131	70	70	64	133	
575-3-60	STD/MED	5	—	—	—	—	15	20	15	90	19	20	20	94	
				425A	18.0	17.3	25	25	23	90	30	30	27	94	
				427A	36.0	34.6	47	50	43	90	52	60	47	94	
	HIGH	5	—	—	—	—	15	20	16	91	19	25	20	95	
				425A	18.0	17.3	26	30	23	91	31	35	28	95	
				427A	36.0	34.6	47	50	43	91	52	60	48	95	

NOTE(S):

- a. High SCCR (Short Circuit Current Rating) is not available on the following: units with Humidi-MiZer system, Low Ambient controls, Phase loss monitor, Non-fused disconnect, and 575V.

## 50FC\*\*09 MCA MOCP ELECTRICAL DATA (cont)

50FC UNIT SIZE	NOM. V-Ph-Hz	IFM TYPE	STD SCCR kA	ELECTRIC HEATER			w/ POWERED CONVENIENCE OUTLET								
				CRHEATER ****00	NOM (kW)	FLA	NO POWER EXHAUST				w/ POWER EXHAUST (powered from unit)				
							MCA	FUSE OR HACR BRKR	DISCONNECT SIZE		MCA	FUSE OR HACR BRKR	DISCONNECT SIZE		
									FLA	LRA			FLA	LRA	
50FC**09	208/230-3-60	STD/MED	5	—	—	—	45	50	48	268	49	60	52	272	
				411A	7.8/10.4	21.7/25.0	45/46	50/50	48/48	268/268	49/50	60/60	52/52	272/272	
				412A	12.0/16.0	33.4/38.5	56/63	60/70	51/57	268/268	61/67	70/70	56/62	272/272	
				414A	18.8/25.0	52.1/60.1	80/90	80/90	73/82	268/268	84/94	90/100	77/86	272/272	
				415A	24.0/32.0	66.7/77.0	98/111	100/125	90/101	268/268	103/115	110/125	94/106	272/272	
				416A	31.8/42.4	88.4/102.0	125/142	125/150	115/130	268/268	130/147	150/150	119/135	272/272	
		HIGH	5	—	—	—	47	50	49	270	270	50	60	53	274
				411A	7.8/10.4	21.7/25.0	47/47	50/50	49/49	270/270	50/52	60/60	53/53	274/274	
				412A	12.0/16.0	33.4/38.5	58/64	60/70	53/58	270/270	62/69	70/70	57/63	274/274	
				414A	18.8/25.0	52.1/60.1	81/91	90/100	74/83	270/270	86/96	90/100	78/88	274/274	
				415A	24.0/32.0	66.7/77.0	99/112	100/125	91/103	270/270	104/117	110/125	95/107	274/274	
				416A	31.8/42.4	88.4/102.0	126/143	150/150	116/131	270/270	131/148	150/150	120/136	274/274	
	460-3-60	STD/MED	5	—	—	—	21	25	22	130	23	25	24	132	
				420A	15.0	18.0	29	30	27	130	32	35	29	132	
				421A	25.0	30.1	45	45	41	130	47	50	43	132	
				422A	33.0	39.7	57	60	52	130	59	60	54	132	
				423A	41.7	50.2	70	70	64	130	72	80	66	132	
				—	—	—	22	25	23	133	24	25	25	135	
		HIGH	5	420A	15.0	18.0	30	30	27	133	32	35	29	135	
				421A	25.0	30.1	45	45	41	133	47	50	43	135	
				422A	33.0	39.7	57	60	52	133	59	60	54	135	
				423A	41.7	50.2	70	70	64	133	73	80	66	135	
				—	—	—	17	20	17	92	20	25	22	96	
				425A	18.0	17.3	27	30	25	92	32	35	29	96	
575-3-60	STD/MED	5	427A	36.0	34.6	49	50	45	92	54	60	49	96		
			—	—	—	17	20	18	93	21	25	22	97		
			425A	18.0	17.3	28	30	25	93	33	35	30	97		
	HIGH	5	427A	36.0	34.6	50	50	45	93	54	60	50	97		

## 50FC\*\*12 MCA MOCPS ELECTRICAL DATA

50FC UNIT SIZE	NOM. V-Ph-Hz	IFM TYPE	STD SCCR KA	HIGH SCCR KA <sup>a</sup>	ELECTRIC HEATER			NO CONVENIENCE OUTLET or UNPOWERED CONVENIENCE OUTLET									
					CRHEATER ****00	NOM (kW)	FLA	NO POWER EXHAUST				w/ POWER EXHAUST (powered from unit)					
								MCA	FUSE OR HACR BRKR	DISCONNECT SIZE		MCA	FUSE OR HACR BRKR	DISCONNECT SIZE			
										FLA	LRA			FLA	LRA		
50FC**12	208/230-3-60	STD/MED	5	10	—	—	—	45	60	47	237	49	60	51	241		
					411A	7.8/10.4	21.7/25.0	45/45	60/60	47/47	237/237	49/49	60/60	51/51	241/241		
					412A	12.0/16.0	33.4/38.5	50/57	60/60	47/52	237/237	55/61	60/70	51/56	241/241		
					415A	24.0/32.0	66.7/77.0	92/105	100/110	84/96	237/237	97/109	100/110	88/100	241/241		
					416A	31.8/42.4	88.4/102.0	119/136	125/150	109/125	237/237	124/141	125/150	113/129	241/241		
					417A	37.6/50.0	104.2/120.3	139/159	150/175	127/146	237/237	143/164	150/175	132/150	241/241		
		HIGH	5	10	—	—	—	51	60	54	246	55	60	58	250		
					411A	7.8/10.4	21.7/25.0	51/51	60/60	54/54	246/246	55/55	60/60	58/58	250/250		
					412A	12.0/16.0	33.4/38.5	58/64	60/70	54/59	246/246	63/69	70/70	58/63	250/250		
					415A	24.0/32.0	66.7/77.0	100/112	100/125	91/103	246/246	104/117	110/125	96/107	250/250		
					416A	31.8/42.4	88.4/102.0	127/144	150/150	116/132	246/246	131/148	150/150	121/136	250/250		
					417A	37.6/50.0	104.2/120.3	146/167	150/175	134/153	246/246	151/171	175/175	139/157	250/250		
	460-3-60	MED	5	10	—	—	—	22	25	23	128	24	30	25	130		
					420A	15.0	18.0	27	30	24	128	29	30	26	130		
					422A	33.0	39.7	54	60	49	128	56	60	51	130		
					423A	41.7	50.2	67	70	61	128	69	70	63	130		
					424A	50.0	60.1	79	80	73	128	82	90	75	130		
					HIGH	5	10	—	—	—	25	30	26	132	27	30	28
		420A	15.0	18.0				30	30	27	132	32	35	29	134		
		422A	33.0	39.7				57	60	52	132	59	60	54	134		
		423A	41.7	50.2				70	70	64	132	72	80	66	134		
		424A	50.0	60.1				83	90	76	132	85	90	78	134		
		575-3-60	MED	5				—	—	—	—	17	20	18	90	21	25
					425A	18.0	17.3		25	25	23	90	30	30	27	94	
427A	36.0				34.6	47	50		43	90	52	60	47	94			
428A	50.0				48.1	64	70		58	90	68	70	63	94			
HIGH	5				—	—	—		—	20	25	20	92	23	25	25	96
						425A	18.0		17.3	28	30	25	92	33	35	30	96
		427A	36.0	34.6		49	50	45	92	54	60	49	96				
		428A	50.0	48.1		66	70	61	92	71	80	65	96				

NOTE(S):

- a. High SCCR (Short Circuit Current Rating) is not available on the following: units with Humidi-MiZer system, Low Ambient controls, Phase loss monitor, Non-fused disconnect, and 575V.

## 50FC\*\*12 MCA MOCP ELECTRICAL DATA (cont)

50FC UNIT SIZE	NOM. V-Ph-Hz	IFM TYPE	STD SCCR kA	ELECTRIC HEATER			w/ POWERED CONVENIENCE OUTLET							
				CRHEATER ****00	NOM (kW)	FLA	NO POWER EXHAUST				w/ POWER EXHAUST (powered from unit)			
							MCA	FUSE OR HACR BRKR	DISCONNECT SIZE		MCA	FUSE OR HACR BRKR	DISCONNECT SIZE	
									FLA	LRA			FLA	LRA
50FC**12	208/230-3-60	STD/MED	5	—	—	—	50	60	52	242	54	60	57	246
				411A	7.8/10.4	21.7/25.0	50/50	60/60	52/52	242/242	54/54	60/60	57/57	246/246
				412A	12.0/16.0	33.4/38.5	56/63	60/70	52/57	242/242	61/67	70/70	57/62	246/246
				415A	24.0/32.0	66.7/77.0	98/111	100/125	90/101	242/242	103/115	110/125	94/106	246/246
				416A	31.8/42.4	88.4/102.0	125/142	125/150	115/130	242/242	130/147	150/150	119/135	246/246
		417A	37.6/50.0	104.2/120.3	145/165	150/175	133/151	242/242	149/170	150/175	137/156	246/246		
		HIGH	5	—	—	—	56	60	59	251	60	70	64	255
				411A	7.8/10.4	21.7/25.0	56/56	60/60	59/59	251/251	60/60	70/70	64/64	255/255
				412A	12.0/16.0	33.4/38.5	64/70	70/70	59/64	251/251	69/75	70/80	64/69	255/255
				415A	24.0/32.0	66.7/77.0	106/118	110/125	97/109	251/251	110/123	110/125	101/113	255/255
	416A			31.8/42.4	88.4/102.0	133/150	150/150	122/137	251/251	137/154	150/175	126/142	255/255	
	417A	37.6/50.0	104.2/120.3	152/173	175/175	140/158	251/251	157/177	175/200	144/163	255/255			
	460-3-60	STD/MED	5	—	—	—	25	30	26	130	26	30	28	132
				420A	15.0	18.0	29	30	27	130	32	35	29	132
				422A	33.0	39.7	57	60	52	130	59	60	54	132
				423A	41.7	50.2	70	70	64	130	72	80	66	132
				424A	50.0	60.1	82	90	75	130	84	90	77	132
		HIGH	5	—	—	—	27	30	29	134	29	35	31	136
				420A	15.0	18.0	33	35	30	134	35	35	32	136
				422A	33.0	39.7	60	60	55	134	62	70	57	136
				423A	41.7	50.2	73	80	67	134	75	80	69	136
				424A	50.0	60.1	85	90	78	134	88	90	80	136
	575-3-60	STD/MED	5	—	—	—	19	25	20	92	23	25	24	96
				425A	18.0	17.3	27	30	25	92	32	35	29	96
				427A	36.0	34.6	49	50	45	92	54	60	49	96
				428A	50.0	48.1	66	70	60	92	71	80	65	96
		HIGH	5	—	—	—	21	25	22	94	25	30	27	98
				425A	18.0	17.3	30	30	27	94	35	35	32	98
427A				36.0	34.6	52	60	47	94	56	60	51	98	
428A				50.0	48.1	68	70	63	94	73	80	67	98	





## 50FC\*\*14 MCA MOCP ELECTRICAL DATA (cont)

50FC UNIT SIZE	NOM. V-Ph-Hz	IFM TYPE	STD SCCR kA	ELECTRIC HEATER			w/ POWERED CONVENIENCE OUTLET							
				CRHEATER ****00	NOM (kW)	FLA	NO POWER EXHAUST				w/ POWER EXHAUST (powered from unit)			
							MCA	FUSE OR HACR BRKR	DISCONNECT SIZE		MCA	FUSE OR HACR BRKR	DISCONNECT SIZE	
									FLA	LRA			FLA	LRA
50FC**14	208/230-3-60	STD/MED	5	—	—	—	68	80	71	308	72	80	75	312
				411A	7.8/10.4	21.7/25.0	68/68	80/80	71/71	308/308	72/72	80/80	75/75	312/312
				412A	12.0/16.0	33.4/38.5	68/68	80/80	71/71	308/308	72/72	80/80	75/75	312/312
				415A	24.0/32.0	66.7/77.0	99/112	100/125	91/103	308/308	104/117	110/125	95/107	312/312
				416A	31.8/42.4	88.4/102.0	126/143	150/150	116/131	308/308	131/148	150/150	120/136	312/312
		417A	37.6/50.0	104.2/120.3	146/166	150/175	134/152	308/308	151/171	175/175	138/157	312/312		
		HIGH	5	—	—	—	73	80	77	315	77	90	81	319
				411A	7.8/10.4	21.7/25.0	73/73	80/80	77/77	315/315	77/77	90/90	81/81	319/319
				412A	12.0/16.0	33.4/38.5	73/73	80/80	77/77	315/315	77/77	90/90	81/81	319/319
				415A	24.0/32.0	66.7/77.0	106/118	110/125	97/109	315/315	110/123	110/125	101/113	319/319
	416A			31.8/42.4	88.4/102.0	133/150	150/150	122/137	315/315	137/154	150/175	126/142	319/319	
	417A	37.6/50.0	104.2/120.3	152/173	175/175	140/158	315/315	157/177	175/200	144/163	319/319			
	460-3-60	STD/MED	5	—	—	—	35	45	37	157	37	45	39	159
				420A	15.0	18.0	35	45	37	157	37	45	39	159
				422A	33.0	39.7	57	60	52	157	59	60	54	159
				423A	41.7	50.2	70	70	64	157	73	80	66	159
				424A	50.0	60.1	83	90	76	157	85	90	78	159
		HIGH	5	—	—	—	37	45	39	158	39	45	41	160
				420A	15.0	18.0	37	45	39	158	39	45	41	160
				422A	33.0	39.7	60	60	55	158	62	70	57	160
				423A	41.7	50.2	73	80	67	158	75	80	69	160
				424A	50.0	60.1	85	90	78	158	88	90	80	160
	575-3-60	STD/MED	5	—	—	—	29	35	30	123	33	35	35	127
				425A	18.0	17.3	29	35	30	123	33	35	35	127
				427A	36.0	34.6	50	50	45	123	54	60	50	127
				428A	50.0	48.1	66	70	61	123	71	80	65	127
		HIGH	5	—	—	—	30	35	32	124	34	40	37	128
				425A	18.0	17.3	30	35	32	124	35	40	37	128
427A				36.0	34.6	52	60	47	124	56	60	51	128	
428A				50.0	48.1	68	70	63	124	73	80	67	128	

## 50FC\*\*16 MCA MOCPS ELECTRICAL DATA

50FC UNIT SIZE	NOM. V-Ph-Hz	IFM TYPE	STD SCCR KA	HIGH SCCR KA <sup>a</sup>	ELECTRIC HEATER			NO CONVENIENCE OUTLET or UNPOWERED CONVENIENCE OUTLET							
					CRHEATER ****00	NOM (kW)	FLA	NO POWER EXHAUST				w/ POWER EXHAUST (powered from unit)			
								MCA	FUSE OR HACR BRKR	DISCONNECT SIZE		MCA	FUSE OR HACR BRKR	DISCONNECT SIZE	
										FLA	LRA			FLA	LRA
50FC**16	208/230-3-60	STD/MED	5	10	—	—	—	67	80	69	398	71	80	73	402
					412A	12.0/16.0	33.4/38.5	67/67	80/80	69/69	398/398	71/71	80/80	73/73	402/402
					414A	18.8/25.0	52.1/60.1	75/85	80/90	69/78	398/398	80/90	80/90	73/82	402/402
					415A	24.0/32.0	66.7/77.0	93/106	100/110	85/97	398/398	98/111	100/125	90/102	402/402
					416A	31.8/42.4	88.4/102.0	120/137	125/150	110/126	398/398	125/142	125/150	115/130	402/402
					417A	37.6/50.0	104.2/120.3	140/160	150/175	128/147	398/398	145/165	150/175	133/151	402/402
		451A	50.3/67.0	139.7/161.2	184/211	200/225	169/194	398/398	189/216	200/225	174/198	402/402			
		HIGH	5	10	—	—	—	72	80	75	405	76	100	79	409
					412A	12.0/16.0	33.4/38.5	72/72	80/80	75/75	405/405	76/76	100/100	79/79	409/409
					414A	18.8/25.0	52.1/60.1	81/91	100/100	75/84	405/405	86/96	100/100	79/88	409/409
					415A	24.0/32.0	66.7/77.0	100/112	100/125	91/103	405/405	104/117	110/125	96/107	409/409
					416A	31.8/42.4	88.4/102.0	127/144	150/150	116/132	405/405	131/148	150/150	121/136	409/409
	417A				37.6/50.0	104.2/120.3	146/167	150/175	134/153	405/405	151/171	175/175	139/157	409/409	
	460-3-60	STD/MED	5	10	—	—	—	33	45	33	209	35	45	35	211
					420A	15.0	18.0	33	45	33	209	35	45	35	211
					421A	25.0	30.1	42	45	39	209	45	45	41	211
					422A	33.0	39.7	54	60	50	209	57	60	52	211
					423A	41.7	50.2	68	70	62	209	70	70	64	211
					452A	67.0	80.6	106	110	97	209	108	110	99	211
		HIGH	5	10	—	—	—	35	45	36	210	37	50	38	212
					420A	15.0	18.0	35	45	36	210	37	50	38	212
421A					25.0	30.1	45	45	41	210	47	50	43	212	
422A					33.0	39.7	57	60	52	210	59	60	54	212	
423A					41.7	50.2	70	70	64	210	72	80	66	212	
424A					50.0	60.1	83	90	76	210	85	90	78	212	
452A	67.0	80.6	108	110	99	210	110	125	101	212					
575-3-60	STD/MED	5	—	—	—	—	26	30	26	160	30	40	30	164	
				425A	18.0	17.3	26	30	26	160	31	40	30	164	
				427A	36.0	34.6	47	50	43	160	52	60	48	164	
				428A	50.0	48.1	64	70	59	160	69	70	63	164	
				453A	67.0	64.5	85	90	78	160	90	90	82	164	
				—	—	—	28	30	28	161	31	40	32	165	
	HIGH	5	—	425A	18.0	17.3	28	30	28	161	33	40	32	165	
				427A	36.0	34.6	49	50	45	161	54	60	49	165	
				428A	50.0	48.1	66	70	61	161	71	80	65	165	
				453A	67.0	64.5	87	90	79	161	92	100	84	165	

NOTE(S):

- a. High SCCR (Short Circuit Current Rating) is not available on the following: units with Humidi-MiZer system, Low Ambient controls, Phase loss monitor, Non-fused disconnect, and 575V.

## 50FC\*\*16 MCA MOCP ELECTRICAL DATA (cont)

50FC UNIT SIZE	NOM. V-Ph-Hz	IFM TYPE	STD SCCR kA	ELECTRIC HEATER			w/ POWERED CONVENIENCE OUTLET							
				CRHEATER ****00	NOM (kW)	FLA	NO POWER EXHAUST				w/ POWER EXHAUST (powered from unit)			
							MCA	FUSE OR HACR BRKR	DISCONNECT SIZE		MCA	FUSE OR HACR BRKR	DISCONNECT SIZE	
									FLA	LRA			FLA	LRA
50FC**16	208/230-3-60	STD/MED	5	—	—	—	72	80	74	403	76	100	79	407
				412A	12.0/16.0	33.4/38.5	72/72	80/80	74/74	403/403	76/76	100/100	79/79	407/407
				414A	18.8/25.0	52.1/60.1	81/91	90/100	74/83	403/403	86/96	100/100	79/88	407/407
				415A	24.0/32.0	66.7/77.0	99/112	100/125	91/103	403/403	104/117	110/125	95/107	407/407
				416A	31.8/42.4	88.4/102.0	126/143	150/150	116/131	403/403	131/148	150/150	120/136	407/407
				417A	37.6/50.0	104.2/120.3	146/166	150/175	134/152	403/403	151/171	175/175	138/157	407/407
				451A	50.3/67.0	139.7/161.2	190/217	200/225	175/200	403/403	195/222	200/225	179/204	407/407
		HIGH	5	—	—	—	77	100	80	410	81	100	85	414
				412A	12.0/16.0	33.4/38.5	77/77	100/100	80/80	410/410	81/81	100/100	85/85	414/414
				414A	18.8/25.0	52.1/60.1	87/97	100/100	80/89	410/410	92/102	100/110	85/93	414/414
				415A	24.0/32.0	66.7/77.0	106/118	110/125	97/109	410/410	110/123	110/125	101/113	414/414
				416A	31.8/42.4	88.4/102.0	133/150	150/150	122/137	410/410	137/154	150/175	126/142	414/414
				417A	37.6/50.0	104.2/120.3	152/173	175/175	140/158	410/410	157/177	175/200	144/163	414/414
				451A	50.3/67.0	139.7/161.2	197/224	200/225	181/205	410/410	202/228	225/250	185/210	414/414
	460-3-60	STD/MED	5	—	—	—	35	45	36	211	37	50	38	213
				420A	15.0	18.0	35	45	36	211	37	50	38	213
				421A	25.0	30.1	45	45	41	211	47	50	43	213
				422A	33.0	39.7	57	60	52	211	59	60	54	213
				423A	41.7	50.2	70	70	64	211	73	80	66	213
				424A	50.0	60.1	83	90	76	211	85	90	78	213
				452A	67.0	80.6	108	110	99	211	111	125	101	213
		HIGH	5	—	—	—	37	50	38	212	39	50	40	214
				420A	15.0	18.0	37	50	38	212	39	50	40	214
				421A	25.0	30.1	48	50	44	212	50	50	46	214
				422A	33.0	39.7	60	60	55	212	62	70	57	214
				423A	41.7	50.2	73	80	67	212	75	80	69	214
				424A	50.0	60.1	85	90	78	212	88	90	80	214
				452A	67.0	80.6	111	125	102	212	113	125	104	214
575-3-60	STD/MED	5	—	—	—	28	35	28	162	31	40	32	166	
			425A	18.0	17.3	28	35	28	162	33	40	32	166	
			427A	36.0	34.6	50	50	45	162	54	60	50	166	
			428A	50.0	48.1	66	70	61	162	71	80	65	166	
			453A	67.0	64.5	87	90	80	162	92	100	84	166	
			—	—	—	29	40	30	163	33	40	34	167	
			425A	18.0	17.3	30	40	30	163	35	40	34	167	
	HIGH	5	427A	36.0	34.6	52	60	47	163	56	60	51	167	
			428A	50.0	48.1	68	70	63	163	73	80	67	167	
			453A	67.0	64.5	89	90	81	163	94	100	86	167	

## 50FC\*\*08 ELECTRIC HEAT DATA — WITHOUT NON-FUSED DISCONNECT

50FC UNIT SIZE	NOM. V-Ph-Hz	IFM TYPE	ELECTRIC HEATER PART NUMBER	NOM (kW)	STD SCCR kA	HIGH SCCR kA <sup>a</sup>	APPLICATION (kW)	APPLICATION OUTPUT (MBH)	SINGLE POINT OR JUNCTION KIT PART NUMBER CRSINGLEXXXA00				
									NO C.O. OR UNPOWERED C.O.		w/PWRD C.O.		
									NO P.E.	w/P.E. (pwrd fr/unit)	NO P.E.	w/P.E. (pwrd fr/unit)	
50FC-M08	208/230-3-60	STD/MED	CRHEATER411A00	10.4	5	10	7.8/9.6	26.7/32.6	042	042	042	042	
			CRHEATER412A00	16	5	10	12.0/14.7	41.0/50.1	042	043	043	043	
			CRHEATER414A00	25	5	10	18.8/23.0	64.1/78.3	043	043	043	043	
			CRHEATER415A00	32	5	10	24.0/29.4	82.0/100.3	043	043	043	043	
			CRHEATER416A00	42.4	5	10	31.8/38.9	108.7/132.9	045	045	045	045	
		HIGH	CRHEATER411A00	10.4	5	10	7.8/9.6	26.7/32.6	042	042	042	042	
			CRHEATER412A00	16	5	10	12.0/14.7	41.0/50.1	042	043	043	043	
			CRHEATER414A00	25	5	10	18.8/23.0	64.1/78.3	043	043	043	043	
			CRHEATER415A00	32	5	10	24.0/29.4	82.0/100.3	043	043	043	043	
			CRHEATER416A00	42.4	5	10	31.8/38.9	108.7/132.9	045	045	045	045	
		460-3-60	STD/MED	CRHEATER420A00	15	5	10	13.8	47.0	042	042	042	042
				CRHEATER421A00	25	5	10	23.0	78.3	042	042	042	042
	CRHEATER422A00			33	5	10	30.3	103.4	042	042	042	042	
	CRHEATER423A00			41.7	5	10	38.3	130.7	044	044	044	044	
	CRHEATER420A00			15	5	10	13.8	47.0	042	042	042	042	
	HIGH		CRHEATER421A00	25	5	10	23.0	78.3	042	042	042	042	
			CRHEATER422A00	33	5	10	30.3	103.4	042	042	042	042	
			CRHEATER423A00	41.7	5	10	38.3	130.7	044	044	044	044	
			CRHEATER425A00	18	5	—	16.5	56.4	042	042	042	042	
			CRHEATER427A00	36	5	—	33.1	112.8	042	042	042	042	
	575-3-60		STD/MED	CRHEATER425A00	18	5	—	16.5	56.4	042	042	042	042
				CRHEATER427A00	36	5	—	33.1	112.8	042	042	042	042
		HIGH	CRHEATER425A00	18	5	—	16.5	56.4	042	042	042	042	
			CRHEATER427A00	36	5	—	33.1	112.8	042	042	042	042	

NOTE(S):

- a. High SCCR (Short Circuit Current Rating) is not available on the following: units with Humidi-MiZer system, Low Ambient controls, Phase loss monitor, Non-fused disconnect, and 575V.

## 50FC\*\*08 ELECTRIC HEAT DATA — WITHOUT NON-FUSED DISCONNECT (CONT)

50FC UNIT SIZE	NOM. V-Ph-Hz	IFM TYPE	ELECTRIC HEATER PART NUMBER	NOM (kW)	STD SCCR kA	HIGH SCCR kA <sup>a</sup>	APPLICATION (kW)	APPLICATION OUTPUT (MBH)	HSCCR SINGLE POINT OR JUNCTION KIT PART NUMBER CRSINGLEXXXA00					
									NO C.O. OR UNPOWERED C.O.		w/PWRD C.O.			
									NO P.E.	w/P.E. (pwrd fr/unit)	NO P.E	w/P.E. (pwrd fr/unit)		
50FC-M08	208/230-3-60	STD/MED	CRHEATER411A00	10.4	5	10	7.8/9.6	26.7/32.6	064	064	064	064		
			CRHEATER412A00	16	5	10	12.0/14.7	41.0/50.1	064	064	064	064		
			CRHEATER414A00	25	5	10	18.8/23.0	64.1/78.3	065	065	065	065		
			CRHEATER415A00	32	5	10	24.0/29.4	82.0/100.3	065	065	065	065		
			CRHEATER416A00	42.4	5	10	31.8/38.9	108.7/132.9	066	066	066	066		
		HIGH	CRHEATER411A00	10.4	5	10	7.8/9.6	26.7/32.6	064	064	064	064		
			CRHEATER412A00	16	5	10	12.0/14.7	41.0/50.1	064	064	064	064		
			CRHEATER414A00	25	5	10	18.8/23.0	64.1/78.3	065	065	065	065		
			CRHEATER415A00	32	5	10	24.0/29.4	82.0/100.3	065	065	065	065		
			CRHEATER416A00	42.4	5	10	31.8/38.9	108.7/132.9	066	066	066	066		
			460-3-60	STD/MED	CRHEATER420A00	15	5	10	13.8	47.0	064	064	064	064
					CRHEATER421A00	25	5	10	23.0	78.3	065	065	065	065
	CRHEATER422A00	33			5	10	30.3	103.4	065	065	065	065		
	HIGH	CRHEATER423A00		41.7	5	10	38.3	130.7	065	065	065	065		
		CRHEATER420A00		15	5	10	13.8	47.0	064	064	064	064		
		CRHEATER421A00		25	5	10	23.0	78.3	065	065	065	065		
	575-3-60	STD/MED	CRHEATER422A00	33	5	10	30.3	103.4	065	065	065	065		
			CRHEATER423A00	41.7	5	10	38.3	130.7	065	065	065	065		
		HIGH	CRHEATER425A00	18	5	—	16.5	56.4	064	064	064	064		
			CRHEATER427A00	36	5	—	33.1	112.8	065	065	065	065		
	575-3-60	HIGH	CRHEATER425A00	18	5	—	16.5	56.4	064	064	064	064		
CRHEATER427A00			36	5	—	33.1	112.8	065	065	065	065			

NOTE(S):

- a. High SCCR (Short Circuit Current Rating) is not available on the following: units with Humidi-MiZer system, Low Ambient controls, Phase loss monitor, Non-fused disconnect, and 575V.

## 50FC\*\*08 ELECTRIC HEAT DATA — WITH NON-FUSED DISCONNECT

50FC UNIT SIZE	NOM. V-Ph-Hz	IFM TYPE	ELECTRIC HEATER PART NUMBER	NOM (kW)	STD SCCR kA	APPLICATION (kW)	APPLICATION OUTPUT (MBH)	SINGLE POINT OR JUNCTION KIT PART NUMBER CRSINGLEXXA00				
								NO C.O. OR UNPOWERED C.O.		w/PWRD C.O.		
								NO P.E.	w/P.E. (pwrd fr/unit)	NO P.E.	w/P.E. (pwrd fr/unit)	
50FC-M08	208/230-3-60	STD/ MED	CRHEATER411A00	10.4	5.0	7.8/9.6	26.7/32.6	042	042	042	042	
			CRHEATER412A00	16.0	5.0	12.0/14.7	41.0/50.1	042	043	043	043	
			CRHEATER414A00	25.0	5.0	18.8/23.0	64.1/78.3	043	043	043	043	
			CRHEATER415A00	32.0	5.0	24.0/29.4	82.0/100.3	043	043	043	043	
			CRHEATER416A00	42.4	5.0	31.8/38.9	108.7/132.9	045	045	045	045	
		HIGH	CRHEATER411A00	10.4	5.0	7.8/9.6	26.7/32.6	042	042	042	042	
			CRHEATER412A00	16.0	5.0	12.0/14.7	41.0/50.1	042	043	043	043	
			CRHEATER414A00	25.0	5.0	18.8/23.0	64.1/78.3	043	043	043	043	
			CRHEATER415A00	32.0	5.0	24.0/29.4	82.0/100.3	043	043	043	043	
			CRHEATER416A00	42.4	5.0	31.8/38.9	108.7/132.9	045	045	045	045	
		460-3-60	STD/ MED	CRHEATER420A00	15.0	5.0	13.8	47.0	042	042	042	042
				CRHEATER421A00	25.0	5.0	23.0	78.3	042	042	042	042
	CRHEATER422A00			33.0	5.0	30.3	103.4	042	042	042	042	
	CRHEATER423A00			41.7	5.0	38.3	130.7	044	044	044	044	
	CRHEATER420A00			15.0	5.0	13.8	47.0	042	042	042	042	
	HIGH		CRHEATER421A00	25.0	5.0	23.0	78.3	042	042	042	042	
			CRHEATER422A00	33.0	5.0	30.3	103.4	042	042	042	042	
			CRHEATER423A00	41.7	5.0	38.3	130.7	044	044	044	044	
			CRHEATER425A00	18.0	5.0	16.5	56.4	042	042	042	042	
			CRHEATER427A00	36.0	5.0	33.1	112.8	042	042	042	042	
	575-3-60		STD/ MED	CRHEATER425A00	18.0	5.0	16.5	56.4	042	042	042	042
				CRHEATER427A00	36.0	5.0	33.1	112.8	042	042	042	042
		HIGH	CRHEATER425A00	18.0	5.0	16.5	56.4	042	042	042	042	
				CRHEATER427A00	36.0	5.0	33.1	112.8	042	042	042	042

## 50FC\*\*09 ELECTRIC HEAT DATA — WITHOUT NON-FUSED DISCONNECT

50FC UNIT SIZE	NOM. V-Ph-Hz	IFM TYPE	ELECTRIC HEATER PART NUMBER	NOM (kW)	STD SCCR kA	HIGH SCCR kA <sup>a</sup>	APPLICATION (kW)	APPLICATION OUTPUT (MBH)	SINGLE POINT OR JUNCTION KIT PART NUMBER CRSINGLEXXXA00				
									NO C.O. OR UNPOWERED C.O.		w/PWRD C.O.		
									NO P.E.	w/P.E. (pwrd fr/unit)	NO P.E.	w/P.E. (pwrd fr/unit)	
50FC-M09	208/230-3-60	STD/MED	CRHEATER411A00	10.4	5	10	7.8/9.6	26.7/32.6	047	047	047	047	
			CRHEATER412A00	16	5	10	12.0/14.7	41.0/50.1	047	049	049	049	
			CRHEATER414A00	25	5	10	18.8/23.0	64.1/78.3	049	049	049	049	
			CRHEATER415A00	32	5	10	24.0/29.4	82.0/100.3	049	049	049	049	
			CRHEATER416A00	42.4	5	10	31.8/38.9	108.7/132.9	051	051	051	051	
		HIGH	CRHEATER411A00	10.4	5	10	7.8/9.6	26.7/32.6	047	047	047	047	
			CRHEATER412A00	16	5	10	12.0/14.7	41.0/50.1	047	049	049	049	
			CRHEATER414A00	25	5	10	18.8/23.0	64.1/78.3	049	049	049	049	
			CRHEATER415A00	32	5	10	24.0/29.4	82.0/100.3	049	049	049	049	
			CRHEATER416A00	42.4	5	10	31.8/38.9	108.7/132.9	051	051	051	051	
		460-3-60	STD/MED	CRHEATER420A00	15	5	10	13.8	47.0	047	047	047	047
				CRHEATER421A00	25	5	10	23.0	78.3	047	047	047	047
	CRHEATER422A00			33	5	10	30.3	103.4	047	047	047	047	
	CRHEATER423A00			41.7	5	10	38.3	130.7	050	050	050	050	
	HIGH		CRHEATER420A00	15	5	10	13.8	47.0	047	047	047	047	
			CRHEATER421A00	25	5	10	23.0	78.3	047	047	047	047	
			CRHEATER422A00	33	5	10	30.3	103.4	047	047	047	047	
			CRHEATER423A00	41.7	5	10	38.3	130.7	050	050	050	050	
	575-3-60		STD/MED	CRHEATER425A00	18	5	—	16.5	56.4	047	047	047	047
				CRHEATER427A00	36	5	—	33.1	112.8	047	047	047	047
			HIGH	CRHEATER425A00	18	5	—	16.5	56.4	047	047	047	047
				CRHEATER427A00	36	5	—	33.1	112.8	047	047	047	047

NOTE(S):

- a. High SCCR (Short Circuit Current Rating) is not available on the following: units with Humidi-MiZer system, Low Ambient controls, Phase loss monitor, Non-fused disconnect, and 575V.

## 50FC\*\*09 ELECTRIC HEAT DATA — WITHOUT NON-FUSED DISCONNECT (CONT)

50FC UNIT SIZE	NOM. V-Ph-Hz	IFM TYPE	ELECTRIC HEATER PART NUMBER	NOM (kW)	STD SCCR kA	HIGH SCCR kA <sup>a</sup>	APPLICATION (kW)	APPLICATION OUTPUT (MBH)	HSCCR SINGLE POINT OR JUNCTION KIT PART NUMBER CRSINGLEXXXA00				
									NO C.O. OR UNPOWERED C.O.		w/PWRD C.O.		
									NO P.E.	w/P.E. (pwrd fr/unit)	NO P.E	w/P.E. (pwrd fr/unit)	
50FC-M09	208/230-3-60	STD/MED	CRHEATER411A00	10.4	5	10	7.8/9.6	26.7/32.6	067	067	067	067	
			CRHEATER412A00	16	5	10	12.0/14.7	41.0/50.1	067	067	067	067	
			CRHEATER414A00	25	5	10	18.8/23.0	64.1/78.3	068	068	068	068	
			CRHEATER415A00	32	5	10	24.0/29.4	82.0/100.3	068	068	068	068	
			CRHEATER416A00	42.4	5	10	31.8/38.9	108.7/132.9	069	069	069	069	
		HIGH	CRHEATER411A00	10.4	5	10	7.8/9.6	26.7/32.6	067	067	067	067	
			CRHEATER412A00	16	5	10	12.0/14.7	41.0/50.1	067	067	067	067	
			CRHEATER414A00	25	5	10	18.8/23.0	64.1/78.3	068	068	068	068	
			CRHEATER415A00	32	5	10	24.0/29.4	82.0/100.3	068	068	068	068	
			CRHEATER416A00	42.4	5	10	31.8/38.9	108.7/132.9	069	069	069	069	
		460-3-60	STD/MED	CRHEATER420A00	15	5	10	13.8	47.0	067	067	067	067
				CRHEATER421A00	25	5	10	23.0	78.3	068	068	068	068
	CRHEATER422A00			33	5	10	30.3	103.4	068	068	068	068	
	CRHEATER423A00			41.7	5	10	38.3	130.7	068	068	068	068	
	HIGH		CRHEATER420A00	15	5	10	13.8	47.0	067	067	067	067	
			CRHEATER421A00	25	5	10	23.0	78.3	068	068	068	068	
			CRHEATER422A00	33	5	10	30.3	103.4	068	068	068	068	
			CRHEATER423A00	41.7	5	10	38.3	130.7	068	068	068	068	
			CRHEATER425A00	18	5	—	16.5	56.4	067	067	067	067	
	575-3-60	STD/MED	CRHEATER427A00	36	5	—	33.1	112.8	068	068	068	068	
			CRHEATER425A00	18	5	—	16.5	56.4	067	067	067	067	
		HIGH	CRHEATER425A00	18	5	—	16.5	56.4	067	067	067	067	
			CRHEATER427A00	36	5	—	33.1	112.8	068	068	068	068	

NOTE(S):

- a. High SCCR (Short Circuit Current Rating) is not available on the following: units with Humidi-MiZer system, Low Ambient controls, Phase loss monitor, Non-fused disconnect, and 575V.



## 50FC\*\*09 ELECTRIC HEAT DATA — WITH NON-FUSED DISCONNECT

50FC UNIT SIZE	NOM. V-Ph-Hz	IFM TYPE	ELECTRIC HEATER PART NUMBER	NOM (kW)	STD SCCR kA	APPLICATION (kW)	APPLICATION OUTPUT (MBH)	SINGLE POINT OR JUNCTION KIT PART NUMBER CRSINGLEXXA00				
								NO C.O. OR UNPOWERED C.O.		w/PWRD C.O.		
								NO P.E.	w/P.E. (pwrd fr/unit)	NO P.E.	w/P.E. (pwrd fr/unit)	
50FC-M09	208/230-3-60	STD/ MED	CRHEATER411A00	10.4	5.0	7.8/9.6	26.7/32.6	047	047	047	047	
			CRHEATER412A00	16.0	5.0	12.0/14.7	41.0/50.1	047	049	049	049	
			CRHEATER414A00	25.0	5.0	18.8/23.0	64.1/78.3	049	049	049	049	
			CRHEATER415A00	32.0	5.0	24.0/29.4	82.0/100.3	049	049	049	049	
			CRHEATER416A00	42.4	5.0	31.8/38.9	108.7/132.9	051	051	051	051	
		HIGH	CRHEATER411A00	10.4	5.0	7.8/9.6	26.7/32.6	047	047	047	047	
			CRHEATER412A00	16.0	5.0	12.0/14.7	41.0/50.1	047	049	049	049	
			CRHEATER414A00	25.0	5.0	18.8/23.0	64.1/78.3	049	049	049	049	
			CRHEATER415A00	32.0	5.0	24.0/29.4	82.0/100.3	049	049	049	049	
			CRHEATER416A00	42.4	5.0	31.8/38.9	108.7/132.9	051	051	051	051	
		460-3-60	STD/ MED	CRHEATER420A00	15.0	5.0	13.8	47.0	047	047	047	047
				CRHEATER421A00	25.0	5.0	23.0	78.3	047	047	047	047
	CRHEATER422A00			33.0	5.0	30.3	103.4	047	047	047	047	
	CRHEATER423A00			41.7	5.0	38.3	130.7	050	050	050	050	
	HIGH		CRHEATER420A00	15.0	5.0	13.8	47.0	047	047	047	047	
			CRHEATER421A00	25.0	5.0	23.0	78.3	047	047	047	047	
			CRHEATER422A00	33.0	5.0	30.3	103.4	047	047	047	047	
			CRHEATER423A00	41.7	5.0	38.3	130.7	050	050	050	050	
			CRHEATER425A00	18.0	5.0	16.5	56.4	047	047	047	047	
	575-3-60	STD/ MED	CRHEATER427A00	36.0	5.0	33.1	112.8	047	047	047	047	
			CRHEATER425A00	18.0	5.0	16.5	56.4	047	047	047	047	
		HIGH	CRHEATER427A00	36.0	5.0	33.1	112.8	047	047	047	047	

## 50FC\*\*12 ELECTRIC HEAT DATA — WITHOUT NON-FUSED DISCONNECT

50FC UNIT SIZE	NOM. V-Ph-Hz	IFM TYPE	ELECTRIC HEATER PART NUMBER	NOM (kW)	STD SCCR kA	HIGH SCCR kA <sup>a</sup>	APPLICATION (kW)	APPLICATION OUTPUT (MBH)	SINGLE POINT OR JUNCTION KIT PART NUMBER CRSINGLEXXXA00				
									NO C.O. OR UNPOWERED C.O.		w/PWRD C.O.		
									NO P.E.	w/P.E. (pwrd fr/unit)	NO P.E.	w/P.E. (pwrd fr/unit)	
50FC-M12	208/230-3-60	STD/MED	CRHEATER411A00	10.4	5	10	7.8/9.6	26.7/32.6	047	047	047	047	
			CRHEATER412A00	16	5	10	12.0/14.7	41.0/50.1	047	049	049	049	
			CRHEATER415A00	32	5	10	24.0/29.4	82.0/100.3	049	049	049	049	
			CRHEATER416A00	42.4	5	10	31.8/38.9	108.7/132.9	051	051	051	051	
			CRHEATER417A00	50	5	10	37.6/45.9	128.1/156.7	051	051	051	051	
		HIGH	CRHEATER411A00	10.4	5	10	7.8/9.6	26.7/32.6	047	047	047	049	
			CRHEATER412A00	16	5	10	12.0/14.7	41.0/50.1	049	049	049	049	
			CRHEATER415A00	32	5	10	24.0/29.4	82.0/100.3	049	049	049	049	
			CRHEATER416A00	42.4	5	10	31.8/38.9	108.7/132.9	051	051	051	051	
			CRHEATER417A00	50	5	10	37.6/45.9	128.1/156.7	051	051	051	051	
		460-3-60	STD/MED	CRHEATER420A00	15	5	10	13.8	47.0	047	047	047	047
				CRHEATER422A00	33	5	10	30.3	103.4	047	047	047	047
	CRHEATER423A00			41.7	5	10	38.3	130.7	050	050	050	050	
	CRHEATER424A00			50	5	10	45.9	156.7	050	050	050	050	
	HIGH		CRHEATER420A00	15	5	10	13.8	47.0	047	047	047	047	
			CRHEATER422A00	33	5	10	30.3	103.4	047	047	047	050	
			CRHEATER423A00	41.7	5	10	38.3	130.7	050	050	050	050	
			CRHEATER424A00	50	5	10	45.9	156.7	050	050	050	050	
	575-3-60		STD/MED	CRHEATER425A00	18	5	—	16.5	56.4	047	047	047	047
				CRHEATER427A00	36	5	—	33.1	112.8	047	047	047	047
			HIGH	CRHEATER428A00	50	5	—	45.9	156.7	050	050	050	050
				CRHEATER425A00	18	5	—	16.5	56.4	047	047	047	047
	CRHEATER427A00	36	5	—	33.1	112.8	047	047	047	047			
	CRHEATER428A00	50	5	—	45.9	156.7	050	050	050	050			

NOTE(S):

- a. High SCCR (Short Circuit Current Rating) is not available on the following: units with Humidi-MiZer system, Low Ambient controls, Phase loss monitor, Non-fused disconnect, and 575V.

## 50FC\*\*12 ELECTRIC HEAT DATA — WITHOUT NON-FUSED DISCONNECT (CONT)

50FC UNIT SIZE	NOM. V-Ph-Hz	IFM TYPE	ELECTRIC HEATER PART NUMBER	NOM (kW)	STD SCCR kA	HIGH SCCR kA <sup>a</sup>	APPLICATION (kW)	APPLICATION OUTPUT (MBH)	HSCCR SINGLE POINT OR JUNCTION KIT PART NUMBER CRSINGLEXXXA00				
									NO C.O. OR UNPOWERED C.O.		w/PWRD C.O.		
									NO P.E.	w/P.E. (pwrd fr/unit)	NO P.E.	w/P.E. (pwrd fr/unit)	
50FC-M12	208/230-3-60	STD/MED	CRHEATER411A00	10.4	5	10	7.8/9.6	26.7/32.6	067	067	067	067	
			CRHEATER412A00	16	5	10	12.0/14.7	41.0/50.1	067	067	067	067	
			CRHEATER415A00	32	5	10	24.0/29.4	82.0/100.3	068	068	068	068	
			CRHEATER416A00	42.4	5	10	31.8/38.9	108.7/132.9	069	069	069	069	
			CRHEATER417A00	50	5	10	37.6/45.9	128.1/156.7	069	069	069	069	
		HIGH	CRHEATER411A00	10.4	5	10	7.8/9.6	26.7/32.6	067	067	067	067	
			CRHEATER412A00	16	5	10	12.0/14.7	41.0/50.1	067	067	067	067	
			CRHEATER415A00	32	5	10	24.0/29.4	82.0/100.3	068	068	068	068	
			CRHEATER416A00	42.4	5	10	31.8/38.9	108.7/132.9	069	069	069	069	
			CRHEATER417A00	50	5	10	37.6/45.9	128.1/156.7	069	069	069	069	
		460-3-60	STD/MED	CRHEATER420A00	15	5	10	13.8	47.0	067	067	067	067
				CRHEATER422A00	33	5	10	30.3	103.4	068	068	068	068
	CRHEATER423A00			41.7	5	10	38.3	130.7	068	068	068	068	
	CRHEATER424A00			50	5	10	45.9	156.7	068	068	068	068	
	HIGH		CRHEATER420A00	15	5	10	13.8	47.0	067	067	067	067	
			CRHEATER422A00	33	5	10	30.3	103.4	068	068	068	068	
			CRHEATER423A00	41.7	5	10	38.3	130.7	068	068	068	068	
			CRHEATER424A00	50	5	10	45.9	156.7	068	068	068	068	
			CRHEATER425A00	18	5	—	16.5	56.4	067	067	067	067	
	575-3-60	STD/MED	CRHEATER427A00	36	5	—	33.1	112.8	068	068	068	068	
			CRHEATER428A00	50	5	—	45.9	156.7	068	068	068	068	
			CRHEATER425A00	18	5	—	16.5	56.4	067	067	067	067	
		HIGH	CRHEATER427A00	36	5	—	33.1	112.8	068	068	068	068	
			CRHEATER428A00	50	5	—	45.9	156.7	068	068	068	068	

NOTE(S):

- a. High SCCR (Short Circuit Current Rating) is not available on the following: units with Humidi-MiZer system, Low Ambient controls, Phase loss monitor, Non-fused disconnect, and 575V.

## 50FC\*\*12 ELECTRIC HEAT DATA — WITH NON-FUSED DISCONNECT

50FC UNIT SIZE	NOM. V-Ph-Hz	IFM TYPE	ELECTRIC HEATER PART NUMBER	NOM (kW)	STD SCCR kA	APPLICATION (kW)	APPLICATION OUTPUT (MBH)	SINGLE POINT OR JUNCTION KIT PART NUMBER CRSINGLEXXXA00				
								NO C.O. OR UNPOWERED C.O.		w/PWRD C.O.		
								NO P.E.	w/P.E. (pwrd fr/unit)	NO P.E.	w/P.E. (pwrd fr/unit)	
50FC-M12	208/230-3-60	STD/ MED	CRHEATER411A00	10.4	5.0	7.8/9.6	26.7/32.6	047	047	047	047	
			CRHEATER412A00	16.0	5.0	12.0/14.7	41.0/50.1	047	049	049	049	
			CRHEATER415A00	32.0	5.0	24.0/29.4	82.0/100.3	049	049	049	049	
			CRHEATER416A00	42.4	5.0	31.8/38.9	108.7/132.9	051	051	051	051	
			CRHEATER417A00	50.0	5.0	37.6/45.9	128.1/156.7	051	051	051	051	
		HIGH	CRHEATER411A00	10.4	5.0	7.8/9.6	26.7/32.6	047	047	047	049	
			CRHEATER412A00	16.0	5.0	12.0/14.7	41.0/50.1	049	049	049	049	
			CRHEATER415A00	32.0	5.0	24.0/29.4	82.0/100.3	049	049	049	049	
			CRHEATER416A00	42.4	5.0	31.8/38.9	108.7/132.9	051	051	051	051	
			CRHEATER417A00	50.0	5.0	37.6/45.9	128.1/156.7	051	051	051	051	
		460-3-60	STD/ MED	CRHEATER420A00	15.0	5.0	13.8	47.0	047	047	047	047
				CRHEATER422A00	33.0	5.0	30.3	103.4	047	047	047	047
	CRHEATER423A00			41.7	5.0	38.3	130.7	050	050	050	050	
	CRHEATER424A00			50.0	5.0	45.9	156.7	050	050	050	050	
	CRHEATER420A00			15.0	5.0	13.8	47.0	047	047	047	047	
	HIGH		CRHEATER422A00	33.0	5.0	30.3	103.4	047	047	047	050	
			CRHEATER423A00	41.7	5.0	38.3	130.7	050	050	050	050	
			CRHEATER424A00	50.0	5.0	45.9	156.7	050	050	050	050	
			CRHEATER425A00	18.0	5.0	16.5	56.4	047	047	047	047	
			CRHEATER427A00	36.0	5.0	33.1	112.8	047	047	047	047	
	575-3-60		STD/ MED	CRHEATER428A00	50.0	5.0	45.9	156.7	050	050	050	050
				CRHEATER425A00	18.0	5.0	16.5	56.4	047	047	047	047
		CRHEATER427A00		36.0	5.0	33.1	112.8	047	047	047	047	
		HIGH	CRHEATER425A00	18.0	5.0	16.5	56.4	047	047	047	047	
CRHEATER427A00			36.0	5.0	33.1	112.8	047	047	047	047		
CRHEATER428A00			50.0	5.0	45.9	156.7	050	050	050	050		

## 50FC\*\*14 ELECTRIC HEAT DATA — WITHOUT NON-FUSED DISCONNECT

50FC UNIT SIZE	NOM. V-Ph-Hz	IFM TYPE	ELECTRIC HEATER PART NUMBER	NOM (kW)	STD SCCR kA	HIGH SCCR kA <sup>a</sup>	APPLICATION (kW)	APPLICATION OUTPUT (MBH)	SINGLE POINT OR JUNCTION KIT PART NUMBER CRSINGLEXXXA00				
									NO C.O. OR UNPOWERED C.O.		w/PWRD C.O.		
									NO P.E.	w/P.E. (pwrd fr/unit)	NO P.E.	w/P.E. (pwrd fr/unit)	
50FC-M14	208/230-3-60	STD/MED	CRHEATER411A00	10.4	5	10	7.8/9.6	26.7/32.6	049	049	049	049	
			CRHEATER412A00	16	5	10	12.0/14.7	41.0/50.1	049	049	049	049	
			CRHEATER415A00	32	5	10	24.0/29.4	82.0/100.3	049	049	049	049	
			CRHEATER416A00	42.4	5	10	31.8/38.9	108.7/132.9	051	051	051	051	
			CRHEATER417A00	50	5	10	37.6/45.9	128.1/156.7	051	051	051	051	
		HIGH	CRHEATER411A00	10.4	5	10	7.8/9.6	26.7/32.6	049	049	049	049	
			CRHEATER412A00	16	5	10	12.0/14.7	41.0/50.1	049	049	049	049	
			CRHEATER415A00	32	5	10	24.0/29.4	82.0/100.3	049	049	049	049	
			CRHEATER416A00	42.4	5	10	31.8/38.9	108.7/132.9	051	051	051	051	
			CRHEATER417A00	50	5	10	37.6/45.9	128.1/156.7	051	051	051	051	
		460-3-60	STD/MED	CRHEATER420A00	15	5	10	13.8	47.0	047	047	047	047
				CRHEATER422A00	33	5	10	30.3	103.4	047	047	047	047
	CRHEATER423A00			41.7	5	10	38.3	130.7	050	050	050	050	
	CRHEATER424A00			50	5	10	45.9	156.7	050	050	050	050	
	HIGH		CRHEATER420A00	15	5	10	13.8	47.0	047	047	047	047	
			CRHEATER422A00	33	5	10	30.3	103.4	047	047	047	050	
			CRHEATER423A00	41.7	5	10	38.3	130.7	050	050	050	050	
			CRHEATER424A00	50	5	10	45.9	156.7	050	050	050	050	
			CRHEATER425A00	18	5	—	16.5	56.4	047	047	047	047	
	575-3-60	STD/MED	CRHEATER427A00	36	5	—	33.1	112.8	047	047	047	047	
			CRHEATER428A00	50	5	—	45.9	156.7	050	050	050	050	
			CRHEATER425A00	18	5	—	16.5	56.4	047	047	047	047	
		HIGH	CRHEATER427A00	36	5	—	33.1	112.8	047	047	047	047	
			CRHEATER428A00	50	5	—	45.9	156.7	050	050	050	050	

NOTE(S):

- a. High SCCR (Short Circuit Current Rating) is not available on the following: units with Humidi-MiZer system, Low Ambient controls, Phase loss monitor, Non-fused disconnect, and 575V.

## 50FC\*\*14 ELECTRIC HEAT DATA — WITHOUT NON-FUSED DISCONNECT (CONT)

50FC UNIT SIZE	NOM. V-Ph-Hz	IFM TYPE	ELECTRIC HEATER PART NUMBER	NOM (kW)	STD SCCR kA	HIGH SCCR kA <sup>a</sup>	APPLICATION (kW)	APPLICATION OUTPUT (MBH)	HSCCR SINGLE POINT OR JUNCTION KIT PART NUMBER CRSINGLEXXXA00				
									NO C.O. OR UNPOWERED C.O.		w/PWRD C.O.		
									NO P.E.	w/P.E. (pwrd fr/unit)	NO P.E.	w/P.E. (pwrd fr/unit)	
50FC-M14	208/230-3-60	STD/MED	CRHEATER411A00	10.4	5	10	7.8/9.6	26.7/32.6	067	067	067	067	
			CRHEATER412A00	16	5	10	12.0/14.7	41.0/50.1	067	067	067	067	
			CRHEATER415A00	32	5	10	24.0/29.4	82.0/100.3	068	068	068	068	
			CRHEATER416A00	42.4	5	10	31.8/38.9	108.7/132.9	069	069	069	069	
			CRHEATER417A00	50	5	10	37.6/45.9	128.1/156.7	069	069	069	069	
		HIGH	CRHEATER411A00	10.4	5	10	7.8/9.6	26.7/32.6	067	067	067	067	
			CRHEATER412A00	16	5	10	12.0/14.7	41.0/50.1	067	067	067	067	
			CRHEATER415A00	32	5	10	24.0/29.4	82.0/100.3	068	068	068	068	
			CRHEATER416A00	42.4	5	10	31.8/38.9	108.7/132.9	069	069	069	069	
			CRHEATER417A00	50	5	10	37.6/45.9	128.1/156.7	069	069	069	069	
		460-3-60	STD/MED	CRHEATER420A00	15	5	10	13.8	47.0	067	067	067	067
				CRHEATER422A00	33	5	10	30.3	103.4	068	068	068	068
	CRHEATER423A00			41.7	5	10	38.3	130.7	068	068	068	068	
	CRHEATER424A00			50	5	10	45.9	156.7	068	068	068	068	
	HIGH		CRHEATER420A00	15	5	10	13.8	47.0	067	067	067	067	
			CRHEATER422A00	33	5	10	30.3	103.4	068	068	068	068	
			CRHEATER423A00	41.7	5	10	38.3	130.7	068	068	068	068	
			CRHEATER424A00	50	5	10	45.9	156.7	068	068	068	068	
			CRHEATER425A00	18	5	—	16.5	56.4	067	067	067	067	
	575-3-60	STD/MED	CRHEATER427A00	36	5	—	33.1	112.8	068	068	068	068	
			CRHEATER428A00	50	5	—	45.9	156.7	068	068	068	068	
			CRHEATER425A00	18	5	—	16.5	56.4	067	067	067	067	
		HIGH	CRHEATER427A00	36	5	—	33.1	112.8	068	068	068	068	
			CRHEATER428A00	50	5	—	45.9	156.7	068	068	068	068	
CRHEATER425A00			18	5	—	16.5	56.4	067	067	067	067		

NOTE(S):

- a. High SCCR (Short Circuit Current Rating) is not available on the following: units with Humidi-MiZer system, Low Ambient controls, Phase loss monitor, Non-fused disconnect, and 575V.

# Electrical data (cont)



## 50FC\*\*14 ELECTRIC HEAT DATA — WITH NON-FUSED DISCONNECT

50FC UNIT SIZE	NOM. V-Ph-Hz	IFM TYPE	ELECTRIC HEATER PART NUMBER	NOM (kW)	STD SCCR kA	APPLICATION (kW)	APPLICATION OUTPUT (MBH)	SINGLE POINT OR JUNCTION KIT PART NUMBER CRSINGLEXXXA00				
								NO C.O. OR UNPOWERED C.O.		w/PWRD C.O.		
								NO P.E.	w/P.E. (pwrd fr/unit)	NO P.E.	w/P.E. (pwrd fr/unit)	
50FC-M14	208/230-3-60	STD/ MED	CRHEATER411A00	10.4	5.0	7.8/9.6	26.7/32.6	049	049	049	049	
			CRHEATER412A00	16.0	5.0	12.0/14.7	41.0/50.1	049	049	049	049	
			CRHEATER415A00	32.0	5.0	24.0/29.4	82.0/100.3	049	049	049	049	
			CRHEATER416A00	42.4	5.0	31.8/38.9	108.7/132.9	051	051	051	051	
			CRHEATER417A00	50.0	5.0	37.6/45.9	128.1/156.7	051	051	051	051	
		HIGH	CRHEATER411A00	10.4	5.0	7.8/9.6	26.7/32.6	049	049	049	049	
			CRHEATER412A00	16.0	5.0	12.0/14.7	41.0/50.1	049	049	049	049	
			CRHEATER415A00	32.0	5.0	24.0/29.4	82.0/100.3	049	049	049	049	
			CRHEATER416A00	42.4	5.0	31.8/38.9	108.7/132.9	051	051	051	051	
			CRHEATER417A00	50.0	5.0	37.6/45.9	128.1/156.7	051	051	051	051	
		460-3-60	STD/ MED	CRHEATER420A00	15.0	5.0	13.8	47.0	047	047	047	047
				CRHEATER422A00	33.0	5.0	30.3	103.4	047	047	047	047
	CRHEATER423A00			41.7	5.0	38.3	130.7	050	050	050	050	
	CRHEATER424A00			50.0	5.0	45.9	156.7	050	050	050	050	
	CRHEATER420A00			15.0	5.0	13.8	47.0	047	047	047	047	
	HIGH		CRHEATER422A00	33.0	5.0	30.3	103.4	047	047	047	050	
			CRHEATER423A00	41.7	5.0	38.3	130.7	050	050	050	050	
			CRHEATER424A00	50.0	5.0	45.9	156.7	050	050	050	050	
			CRHEATER425A00	18.0	5.0	16.5	56.4	047	047	047	047	
			CRHEATER427A00	36.0	5.0	33.1	112.8	047	047	047	047	
	575-3-60		STD/ MED	CRHEATER428A00	50.0	5.0	45.9	156.7	050	050	050	050
				CRHEATER425A00	18.0	5.0	16.5	56.4	047	047	047	047
		CRHEATER427A00		36.0	5.0	33.1	112.8	047	047	047	047	
		HIGH	CRHEATER425A00	18.0	5.0	16.5	56.4	047	047	047	047	
CRHEATER427A00			36.0	5.0	33.1	112.8	047	047	047	047		
CRHEATER428A00			50.0	5.0	45.9	156.7	050	050	050	050		

## 50FC\*\*16 ELECTRIC HEAT DATA — WITHOUT NON-FUSED DISCONNECT

50FC UNIT SIZE	NOM. V-Ph-Hz	IFM TYPE	ELECTRIC HEATER PART NUMBER	NOM (kW)	STD SCCR kA	HIGH SCCR kA <sup>a</sup>	APPLICATION (kW)	APPLICATION OUTPUT (MBH)	SINGLE POINT OR JUNCTION KIT PART NUMBER CRSINGLEXXA00			
									NO C.O. OR UNPOWERED C.O.		w/PWRD C.O.	
									NO P.E.	w/P.E. (pwrd fr/unit)	NO P.E.	w/P.E. (pwrd fr/unit)
50FC-M16	208/230-3-60	STD/MED	CRHEATER412A00	16	5	10	12.0/14.7	41.0/50.1	049	049	049	049
			CRHEATER414A00	25	5	10	18.8/23.0	64.1/78.3	049	049	049	049
			CRHEATER415A00	32	5	10	24.0/29.4	82.0/100.3	049	049	049	049
			CRHEATER416A00	42.4	5	10	31.8/38.9	108.7/132.9	051	051	051	051
			CRHEATER417A00	50	5	10	37.6/45.9	128.1/156.7	051	051	051	051
			CRHEATER451A00	67	5	10	50.3/61.5	171.7/210.0	053	053	053	053
		HIGH	CRHEATER412A00	16	5	10	12.0/14.7	41.0/50.1	049	049	049	049
			CRHEATER414A00	25	5	10	18.8/23.0	64.1/78.3	049	049	049	049
			CRHEATER415A00	32	5	10	24.0/29.4	82.0/100.3	049	049	049	049
			CRHEATER416A00	42.4	5	10	31.8/38.9	108.7/132.9	051	051	051	051
			CRHEATER417A00	50	5	10	37.6/45.9	128.1/156.7	051	051	051	051
			CRHEATER451A00	67	5	10	50.3/61.5	171.7/210.0	053	053	053	053
	460-3-60	STD/MED	CRHEATER420A00	15	5	10	13.8	47.0	—	—	—	—
			CRHEATER421A00	25	5	10	23.0	78.3	047	047	047	047
			CRHEATER422A00	33	5	10	30.3	103.4	047	047	047	047
			CRHEATER423A00	41.7	5	10	38.3	130.7	050	050	050	050
			CRHEATER424A00	50	5	10	45.9	156.7	050	050	050	050
			CRHEATER452A00	67	5	10	61.5	210.0	052	052	052	052
		HIGH	CRHEATER420A00	15	5	10	13.8	47.0	-	-	-	-
			CRHEATER421A00	25	5	10	23.0	78.3	047	047	047	047
			CRHEATER422A00	33	5	10	30.3	103.4	047	047	047	050
			CRHEATER423A00	41.7	5	10	38.3	130.7	050	050	050	050
			CRHEATER424A00	50	5	10	45.9	156.7	050	050	050	050
			CRHEATER452A00	67	5	10	61.5	210.0	052	052	052	052
	575-3-60	STD/MED	CRHEATER425A00	18	5	—	16.5	56.4	—	—	—	—
			CRHEATER427A00	36	5	—	33.1	112.8	047	047	047	047
			CRHEATER428A00	50	5	—	45.9	156.7	050	050	050	050
			CRHEATER453A00	67	5	—	61.5	210.0	052	052	052	052
HIGH		CRHEATER425A00	18	5	—	16.5	56.4	—	—	—	—	
		CRHEATER427A00	36	5	—	33.1	112.8	047	047	047	047	
		CRHEATER428A00	50	5	—	45.9	156.7	050	050	050	050	
		CRHEATER453A00	67	5	—	61.5	210.0	052	052	052	052	

NOTE(S):

- a. High SCCR (Short Circuit Current Rating) is not available on the following: units with Humidi-MiZer system, Low Ambient controls, Phase loss monitor, Non-fused disconnect, and 575V.



## 50FC\*\*16 ELECTRIC HEAT DATA — WITHOUT NON-FUSED DISCONNECT (CONT)

50FC UNIT SIZE	NOM. V-Ph-Hz	IFM TYPE	ELECTRIC HEATER PART NUMBER	NOM (kW)	STD SCCR kA	HIGH SCCR kA <sup>a</sup>	APPLICATION (kW)	APPLICATION OUTPUT (MBH)	HSCCR SINGLE POINT OR JUNCTION KIT PART NUMBER CRSINGLEXXXA00			
									NO C.O. OR UNPOWERED C.O.		w/PWRD C.O.	
									NO P.E.	w/P.E. (pwrd fr/unit)	NO P.E	w/P.E. (pwrd fr/unit)
50FC-M16	208/230-3-60	STD/MED	CRHEATER412A00	16	5	10	12.0/14.7	41.0/50.1	067	067	067	067
			CRHEATER414A00	25	5	10	18.8/23.0	64.1/78.3	068	068	068	068
			CRHEATER415A00	32	5	10	24.0/29.4	82.0/100.3	068	068	068	068
			CRHEATER416A00	42.4	5	10	31.8/38.9	108.7/132.9	069	069	069	069
			CRHEATER417A00	50	5	10	37.6/45.9	128.1/156.7	069	069	069	069
			CRHEATER451A00	67	5	10	50.3/61.5	171.7/210.0	070	070	070	070
		HIGH	CRHEATER412A00	16	5	10	12.0/14.7	41.0/50.1	067	067	067	067
			CRHEATER414A00	25	5	10	18.8/23.0	64.1/78.3	068	068	068	068
			CRHEATER415A00	32	5	10	24.0/29.4	82.0/100.3	068	068	068	068
			CRHEATER416A00	42.4	5	10	31.8/38.9	108.7/132.9	069	069	069	069
			CRHEATER417A00	50	5	10	37.6/45.9	128.1/156.7	069	069	069	069
			CRHEATER451A00	67	5	10	50.3/61.5	171.7/210.0	070	070	070	070
	460-3-60	STD/MED	CRHEATER420A00	15	5	10	13.8	47.0	067	067	067	067
			CRHEATER421A00	25	5	10	23.0	78.3	068	068	068	068
			CRHEATER422A00	33	5	10	30.3	103.4	068	068	068	068
			CRHEATER423A00	41.7	5	10	38.3	130.7	068	068	068	068
			CRHEATER424A00	50	5	10	45.9	156.7	068	068	068	068
			CRHEATER452A00	67	5	10	61.5	210.0	069	069	069	069
		HIGH	CRHEATER420A00	15	5	10	13.8	47.0	067	067	067	067
			CRHEATER421A00	25	5	10	23.0	78.3	068	068	068	068
			CRHEATER422A00	33	5	10	30.3	103.4	068	068	068	068
			CRHEATER423A00	41.7	5	10	38.3	130.7	068	068	068	068
			CRHEATER424A00	50	5	10	45.9	156.7	068	068	068	068
			CRHEATER452A00	67	5	10	61.5	210.0	069	069	069	069
	575-3-60	STD/MED	CRHEATER425A00	18	5	—	16.5	56.4	067	067	067	067
			CRHEATER427A00	36	5	—	33.1	112.8	068	068	068	068
			CRHEATER428A00	50	5	—	45.9	156.7	068	068	068	068
			CRHEATER453A00	67	5	—	61.5	210.0	069	069	069	069
HIGH		CRHEATER425A00	18	5	—	16.5	56.4	067	067	067	067	
		CRHEATER427A00	36	5	—	33.1	112.8	068	068	068	068	
		CRHEATER428A00	50	5	—	45.9	156.7	068	068	068	068	
		CRHEATER453A00	67	5	—	61.5	210.0	069	069	069	069	

NOTE(S):

- a. High SCCR (Short Circuit Current Rating) is not available on the following: units with Humidi-MiZer system, Low Ambient controls, Phase loss monitor, Non-fused disconnect, and 575V.

## 50FC\*\*16 ELECTRIC HEAT DATA — WITH NON-FUSED DISCONNECT

50FC UNIT SIZE	NOM. V-Ph-Hz	IFM TYPE	ELECTRIC HEATER PART NUMBER	NOM (kW)	STD SCCR kA	APPLICATION (kW)	APPLICATION OUTPUT (MBH)	SINGLE POINT OR JUNCTION KIT PART NUMBER CRSINGLEXXXA00			
								NO C.O. OR UNPOWERED C.O.		w/PWRD C.O.	
								NO P.E.	w/P.E. (pwrd fr/unit)	NO P.E.	w/P.E. (pwrd fr/unit)
50FC-M16	208/230-3-60	STD/ MED	CRHEATER412A00	16.0	5.0	12.0/14.7	41.0/50.1	049	049	049	049
			CRHEATER414A00	25.0	5.0	18.8/23.0	64.1/78.3	049	049	049	049
			CRHEATER415A00	32.0	5.0	24.0/29.4	82.0/100.3	049	049	049	049
			CRHEATER416A00	42.4	5.0	31.8/38.9	108.7/132.9	051	051	051	051
			CRHEATER417A00	50.0	5.0	37.6/45.9	128.1/156.7	051	051	051	051
			CRHEATER451A00	67.0	5.0	50.3/61.5	171.7/210.0	053	053	053	053
		HIGH	CRHEATER412A00	16.0	5.0	12.0/14.7	41.0/50.1	049	049	049	049
			CRHEATER414A00	25.0	5.0	18.8/23.0	64.1/78.3	049	049	049	049
			CRHEATER415A00	32.0	5.0	24.0/29.4	82.0/100.3	049	049	049	049
			CRHEATER416A00	42.4	5.0	31.8/38.9	108.7/132.9	051	051	051	051
			CRHEATER417A00	50.0	5.0	37.6/45.9	128.1/156.7	051	051	051	051
			CRHEATER451A00	67.0	5.0	50.3/61.5	171.7/210.0	053	053	053	053
	460-3-60	STD/ MED	CRHEATER420A00	15.0	5.0	13.8	47.0	—	—	—	—
			CRHEATER421A00	25.0	5.0	23.0	78.3	047	047	047	047
			CRHEATER422A00	33.0	5.0	30.3	103.4	047	047	047	047
			CRHEATER423A00	41.7	5.0	38.3	130.7	050	050	050	050
			CRHEATER424A00	50.0	5.0	45.9	156.7	050	050	050	050
			CRHEATER452A00	67.0	5.0	61.5	210.0	052	052	052	052
		HIGH	CRHEATER420A00	15.0	5.0	13.8	47.0	—	—	—	—
			CRHEATER421A00	25.0	5.0	23.0	78.3	047	047	047	047
			CRHEATER422A00	33.0	5.0	30.3	103.4	047	047	047	050
			CRHEATER423A00	41.7	5.0	38.3	130.7	050	050	050	050
			CRHEATER424A00	50.0	5.0	45.9	156.7	050	050	050	050
			CRHEATER452A00	67.0	5.0	61.5	210.0	052	052	052	052
575-3-60	STD/ MED	CRHEATER425A00	18.0	5.0	16.5	56.4	—	—	—	—	
		CRHEATER427A00	36.0	5.0	33.1	112.8	047	047	047	047	
		CRHEATER428A00	50.0	5.0	45.9	156.7	050	050	050	050	
		CRHEATER453A00	67.0	5.0	61.5	210.0	052	052	052	052	
	HIGH	CRHEATER425A00	18.0	5.0	16.5	56.4	—	—	—	—	
		CRHEATER427A00	36.0	5.0	33.1	112.8	047	047	047	047	
		CRHEATER428A00	50.0	5.0	45.9	156.7	050	050	050	050	
		CRHEATER453A00	67.0	5.0	61.5	210.0	052	052	052	052	

## Typical Control Wiring Diagram — 48FC 08-12 208-230/460/575-3-60 Unit with Electro-Mechanical Control and W7220 Economizer

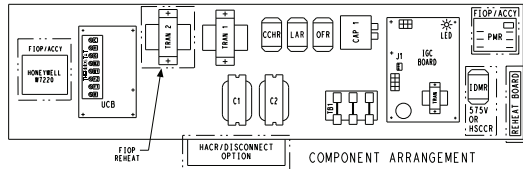

- NOTES:**
1. UCB SCHEMATIC LAYOUT DOES NOT MATCH ACTUAL TERMINAL BOARD LAYOUT.
  2. TERMINAL BOARD JUMPERS 1, 2 AND 3 ARE CUT FOR REHEAT UNITS ONLY.
  3. REMOVE DESIGNATED JUMPERS ON UCB WHEN ADJUSTING SMOKE DETECTORS, OCCUPANCY AND REMOTE SHUTDOWN.
  4. USE ABC AS COARSE AND POT AS FINE ADJUSTMENTS FOR SETTING HIGH FAN SPEED. LOW SPEED IS AN OFFSET BASED ON DIP SWITCHES.
  5. 2-PIN LOW SPEED DIP SWITCH POSITIONS ARE FACTORY SET AS SHOWN. EXCEPTION ON 8.5 TON UNITS; THESE ARE SET TO "ON-ON".
  6. HARDCON AND CUTOFF SET TO "MINI"; JUMPER P-IN ON TOP 2-PINS AS SHOWN.
  7. THE + WIRE COLOR IS FOR DIFFERENTIATION WITHIN THIS SCHEMATIC.
  8. TRANSFORMER IS DEDICATED BASED ON UNIT VOLTAGE. TAPS ONLY SHOWN TO SIMPLIFY SCHEMATIC. 208/230V UNIT TRAIN IS WIRING FOR 200V UNIT. IF UNIT IS TO BE RUN WITH 200V POWER SUPPLY DISCONNECT BLN WIRE FROM 230V TAP AND CONNECT TO 200V TAP.
  9. IGC P3 SETTING: 30 SEC.

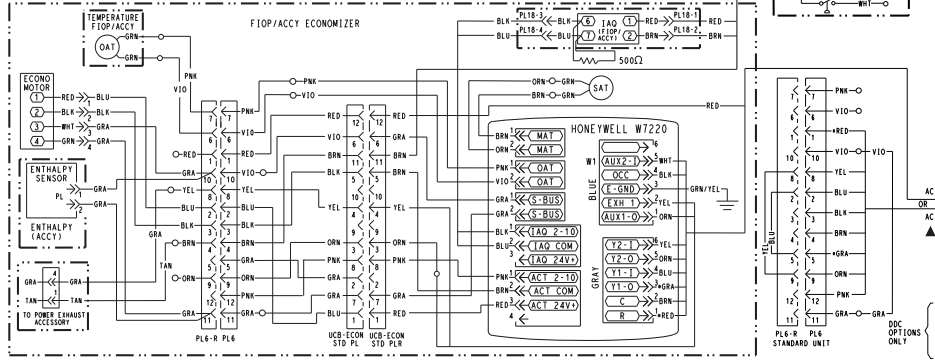
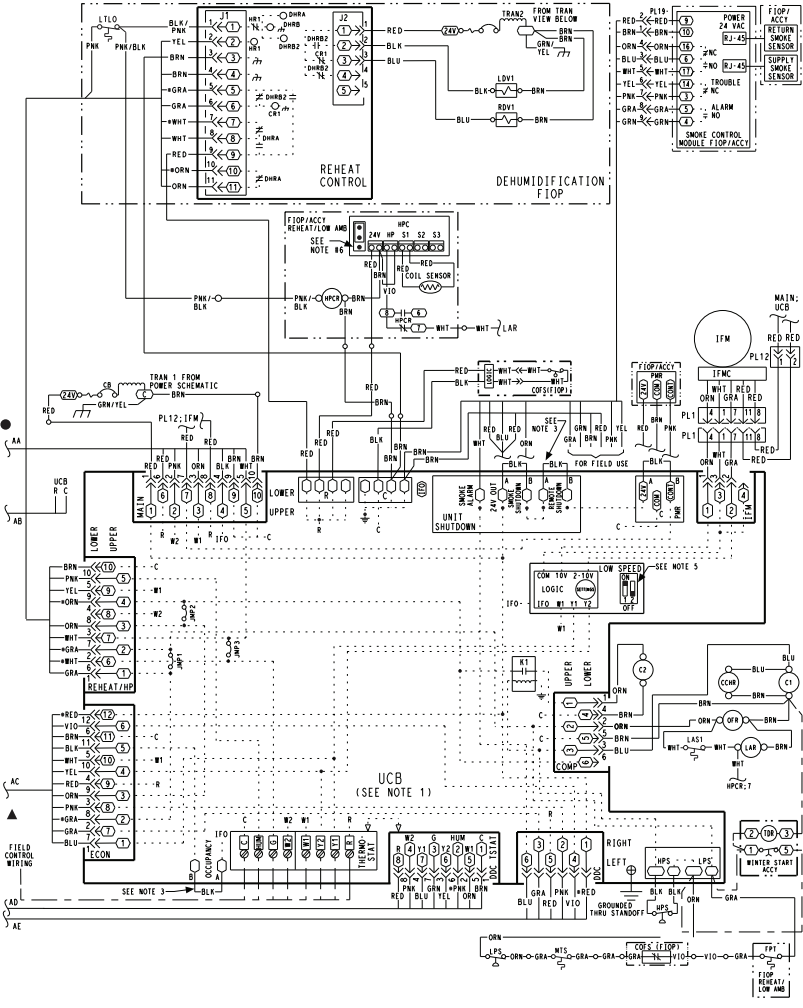
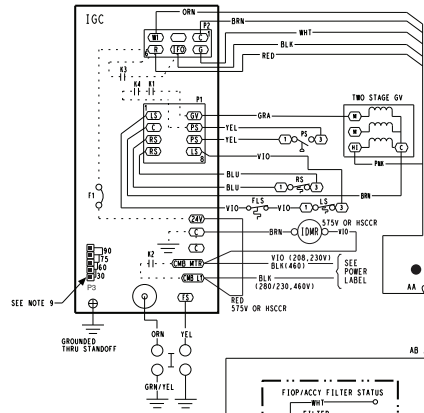
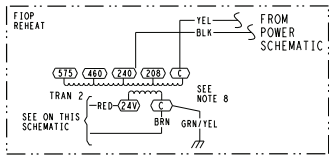

YAC CONTROL 230/460/575V T1 7.5-10 TON

48TMD05713 | C



## Typical Control Wiring Diagram — 48FC 08-12 208-230/460/575-3-60 Unit with SystemVu™ Controller

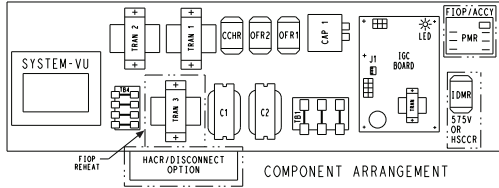

- NOTES:**
1. LOW VOLTAGE CONNECTIONS MUST BE CLASS 2.
  2. USB-B AT J4 AND ETHERNETS AT J12, J14 ARE SHOWN FOR FUTURE USE.
  3. THE "YES" TERMINAL IS CONFIGURABLE IN THE SOFTWARE.
  4. HARDCSTART AND CUTOFF SET TO "MIN". JUMPER PIN ON TOP 2-PINS AS SHOWN.
  5. WHEN USING A BARN SENSOR, MAKE CONNECTION IN THE RETURN AIR SECTION. WHEN USING SPRH SENSOR, MAKE CONNECTION HERE BY DISCONNECTING YELLOW WIRE.
  6. IGC P3 SETTING: 30 SEC.
  7. DISCONNECT V10 TO ALLOW POWER EXHAUST CONNECTION.
  8. TRANSFORMER IS DEDICATED BASED ON UNIT VOLTAGE. TAPS ONLY SHOWN TO SIMPLIFY SCHEMATIC. 208/230V UNIT TRAN IS WIRED FOR 230V UNIT. IF UNIT IS TO BE RUN WITH 208V POWER SUPPLY DISCONNECT BLK WIRE FROM 230V TAP AND CONNECT TO 200V TAP.

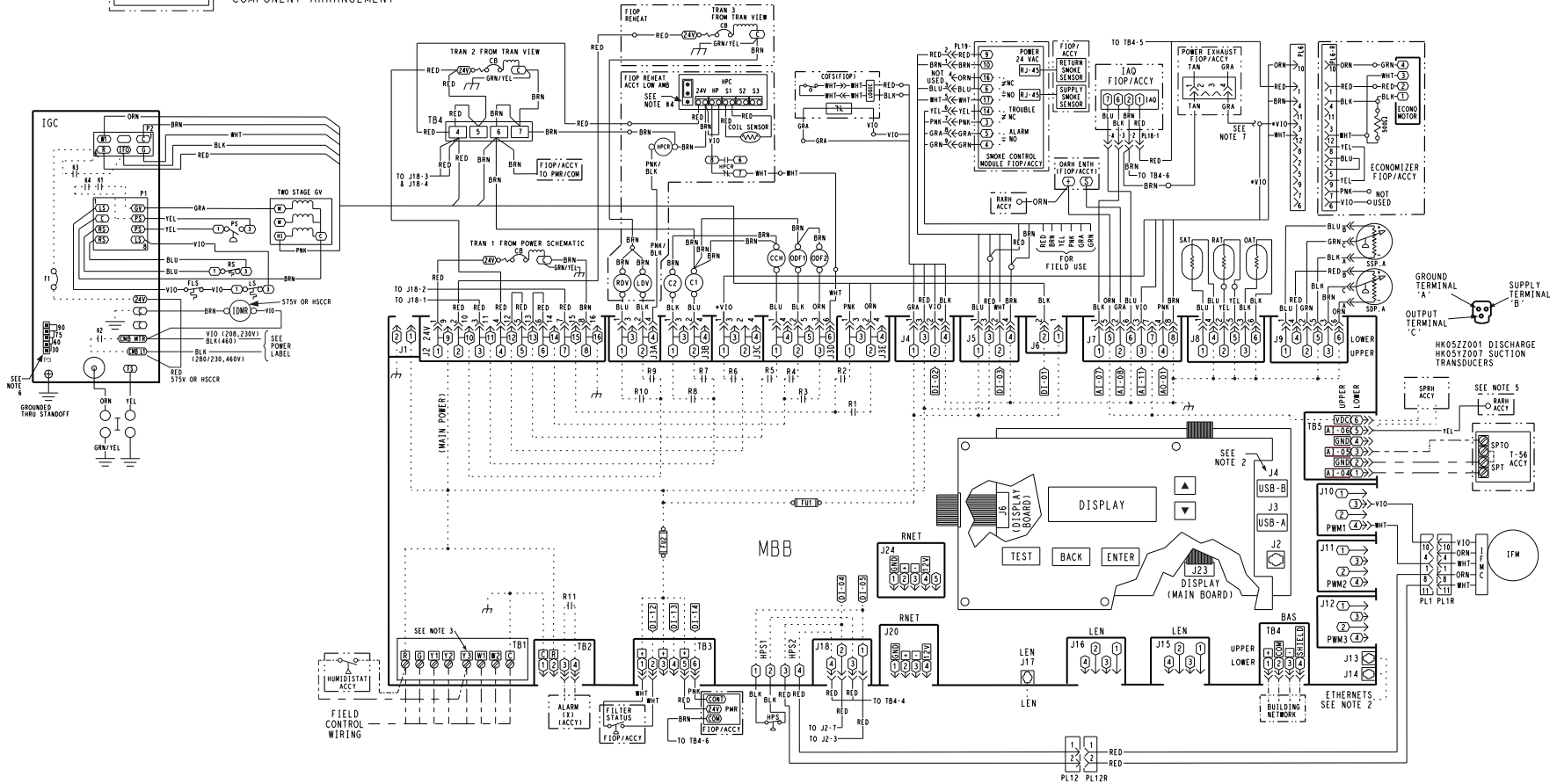
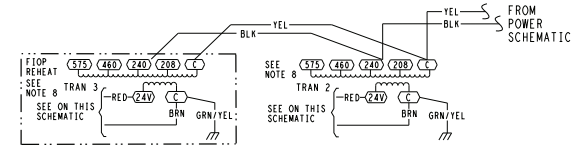

YAC CONTROL 230/460/575V SVU T1 7.5-10 TON 48TM006351 B



## Typical Power Wiring Diagram — 48FC 08-12 208-230/460-3-60 Unit with Electro-Mechanical or SystemVu™ Controllers

YAC POWER 230/460V  
T1 7.5-10 TON

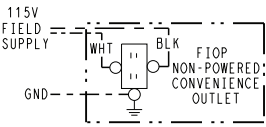
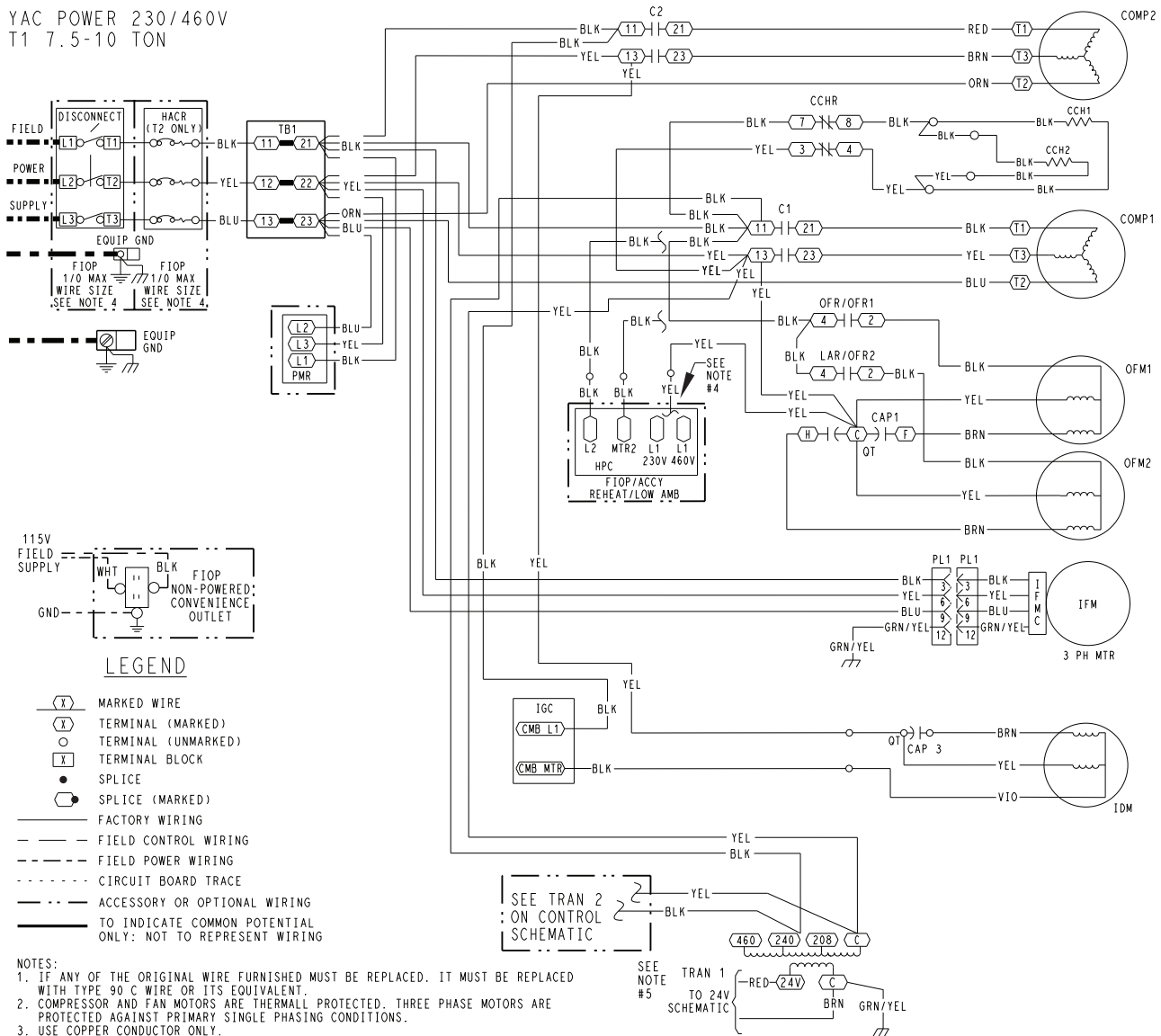

### LEGEND

- (X) MARKED WIRE
- (I) TERMINAL (MARKED)
- (O) TERMINAL (UNMARKED)
- (Y) TERMINAL BLOCK
- SPLICE
- SPLICE (MARKED)
- FACTORY WIRING
- - - FIELD CONTROL WIRING
- - - FIELD POWER WIRING
- · - · - CIRCUIT BOARD TRACE
- · - · - ACCESSORY OR OPTIONAL WIRING
- TO INDICATE COMMON POTENTIAL ONLY: NOT TO REPRESENT WIRING

### NOTES:

1. IF ANY OF THE ORIGINAL WIRE FURNISHED MUST BE REPLACED, IT MUST BE REPLACED WITH TYPE 90 C WIRE OR ITS EQUIVALENT.
2. COMPRESSOR AND FAN MOTORS ARE THERMALLY PROTECTED. THREE PHASE MOTORS ARE PROTECTED AGAINST PRIMARY SINGLE PHASING CONDITIONS.
3. USE COPPER CONDUCTOR ONLY.
4. YELLOW WIRE CONNECTED TO RESPECTIVE VOLTAGE TAP.
5. TRANSFORMER IS DEDICATED BASED ON UNIT VOLTAGE. TAPS ONLY SHOWN TO SIMPLIFY SCHEMATIC. 208/230V UNIT TRAN IS WIRED FOR 230V UNIT. IF UNIT IS TO BE RUN WITH 208V POWER SUPPLY DISCONNECT BLK WIRE FROM 230V TAP AND CONNECT TO 208V TAP.

ACCY	ACCESSORY	HS	HALL EFFECT SENSOR	OFM	OUTDOOR FAN MOTOR
AMB	AMBIENT	I	IGNITOR	OFR	OUTDOOR FAN RELAY
C	CONTACTOR, COMPRESSOR	IAQ	INDOOR AIR QUALITY SENSORS	OL	OVERLOAD
CAP	CAPACITOR	IDM	INDUCED DRAFT MOTOR	PL	PLUG ASSEMBLY
CB	CIRCUIT BREAKER	IFCB	INDOOR FAN CIRCUIT BREAKER	POT	POTENTIOMETER
CCH	CRANKCASE HEATER	IFM	INDOOR FAN MOTOR	PRM	PHASE MONITOR RELAY
CCHR	CRANKCASE HEATER RELAY	IFMC	INDOOR FAN CONTROLLER	QT	QUADRUPLE TERMINAL
CMB	COMBUSTION	IGC	INTEGRATED GAS CONTROL	RARH	RETURN AIR RELATIVE HUMIDITY
COFS	CONDENSATE OVERFLOW SWT	JMP	JUMPER	RAT	RETURN AIR TEMP. SENSOR
COMP	COMPRESSOR MOTOR	LA	LOW AMBIENT	RDV	REHEAT DISCHARGE VALVE
DDC	DIRECT DIGITAL CONTROL	LDV	LIQUID DIVERTER VALVE	RS	ROLLOUT SWITCH
ERV	ENERGY RECOVERY VENTILATOR	LPS	LOW PRESSURE SWITCH	SAT	SUPPLY AIR TEMP. SENSOR
FIOP	FACTORY INSTALLED OPTION	LSM	LIMIT SWITCH (MANUAL RESET)	SEN	SENSOR
FLS	FAN LIMIT SWITCH	LS	LIMIT SWITCH	SPRH	SENSOR RELATIVE HUMIDITY
FPT	FREEZE PROTECTION THERMOSTAT	LTLO	LOW TEMPERATURE LOCKOUT	SPT	SPACE TEMPERATURE SENSOR
FSD	FIRE SHUT DOWN	MGV	MAIN GAS VALVE	SPTO	SPACE TEMPERATURE OFFSET
FS	FLAME SENSOR	MOV	VOLTAGE RESTRICTOR	STD	STANDARD
FU	FUSE	MTR	MOTOR	TB	TERMINAL BLOCK
GND	GROUND	MTS	MIXED AIR TEMPERATURE SWITCH	TDR	TIME DELAY RELAY (WINTER START)
GVR	GAS VALVE RELAY	OAO	OUTDOOR AIR QUALITY	TRAN	TRANSFORMER
HPC	HEAD PRESSURE CONTROL	OARH	OUTSIDE AIR RELATIVE HUMIDITY	UCB	UNIT CONTROL BOARD
HPS	HIGH PRESSURE SWITCH	OAT	OUTDOOR AIR TEMP. SENSOR		

48TM005719 C

### Typical Control Wiring Diagram — 48FC 14 208-230/460/575-3-60 Unit with Electro-Mechanical Control and W7220 Economizer

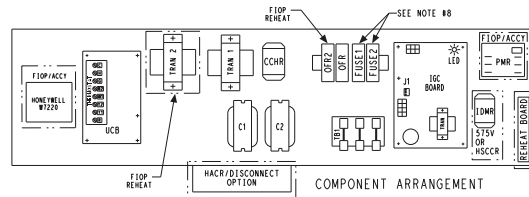

- NOTES:**
1. UCB SCHEMATIC LAYOUT DOES NOT MATCH ACTUAL TERMINAL BOARD LAYOUT.
  2. TERMINAL BOARD JUMPERS 1, 2 AND 3 ARE CUT FOR REHEAT UNITS ONLY.
  3. REMOVE DESIGNATED JUMPERS ON UCB WHEN ADDING SMOKE DETECTORS, OCCUPANCY AND REMOTE SHUTDOWN.
  4. USE ABC AS COARSE AND POT AS FINE ADJUSTMENTS FOR SETTING REHEAT SPEED. LOW SPEED IS AN OFFSET BASED ON DIP SWITCHES.
  5. 2-PIN LOW SPEED DIP SWITCH POSITIONS ARE FACTORY SET AS SHOWN.
  6. HARDSTART AND CUTOFF SET TO "MFR". JUMPER PIN ON TOP 2-PINS AS SHOWN.
  7. THE 4 WIRE COLOR IS FOR DIFFERENTIATION WITHIN THIS SCHEMATIC.
  8. FUSES FOR 230V ARE LOCATED IN CONTROL BOX. FUSES FOR 460/575V ARE LOCATED BELOW THE CONTROL BOX.
  9. IGC P3 SETTING: 30 SEC.
  10. TRANSFORMER IS DEREGULATED BASED ON UNIT VOLTAGE. TAPS ONLY SHOWN TO SIMPLIFY SCHEMATIC. 208/230V UNIT TRAN IS WIRED FOR 230V UNIT. IF UNIT IS TO BE RUN WITH 208V POWER SUPPLY DISCONNECT BLK WIRE FROM 230V TAP AND CONNECT TO 200V TAP.

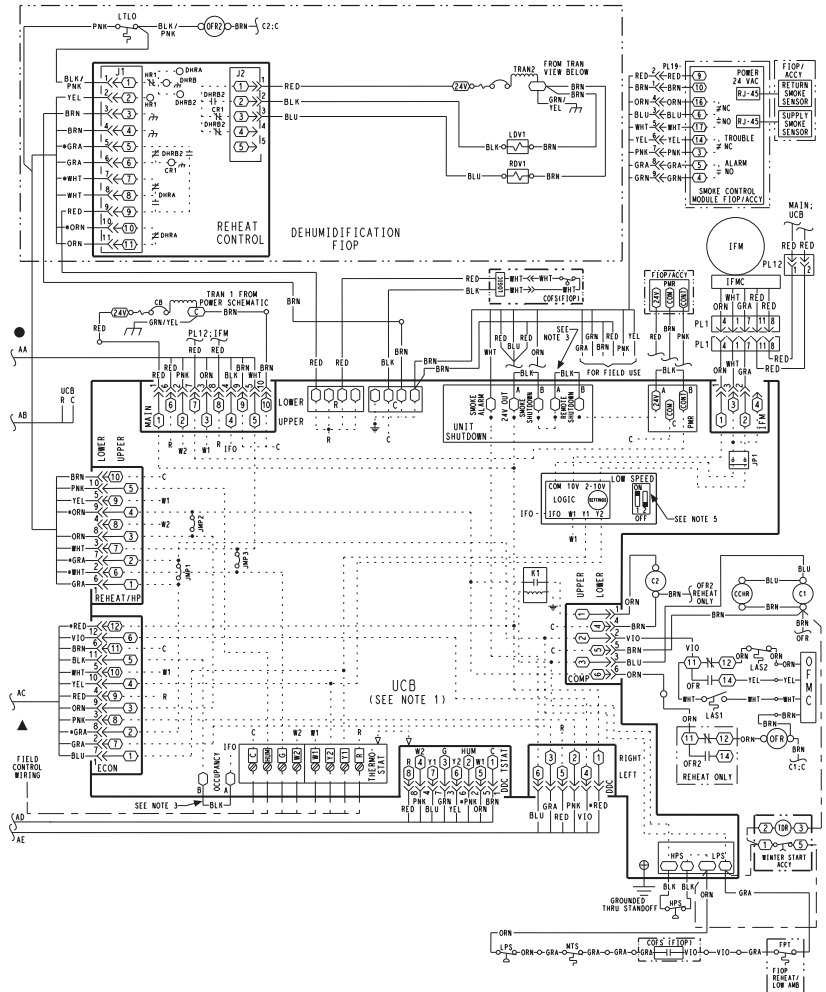
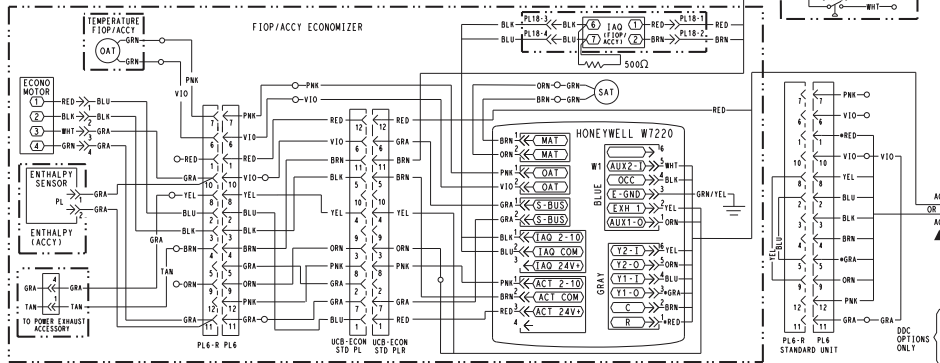
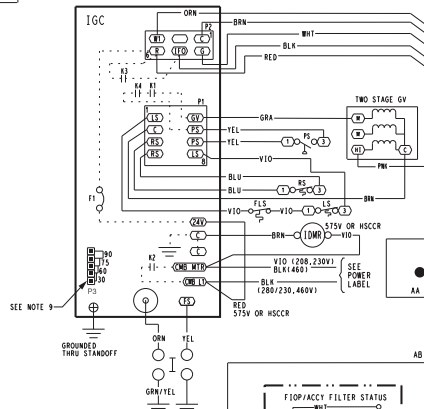
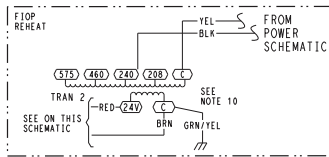

YAC CONTROL 230/460/575V T1 12.5 TON

48TMO05989 C



## Typical Power Wiring Diagram — 48FC 14 208-230/3/60 Unit with Electro-Mechanical Controller

YAC POWER 230V  
T1 12.5 TON

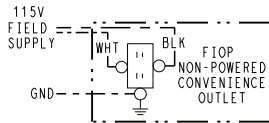
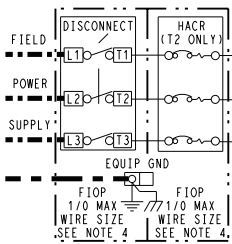

### LEGEND

- MARKED WIRE
- TERMINAL (MARKED)
- TERMINAL (UNMARKED)
- TERMINAL BLOCK
- SPLICE
- SPLICE (MARKED)
- FACTORY WIRING
- FIELD CONTROL WIRING
- FIELD POWER WIRING
- CIRCUIT BOARD TRACE
- ACCESSORY OR OPTIONAL WIRING
- TO INDICATE COMMON POTENTIAL ONLY: NOT TO REPRESENT WIRING

### NOTES:

1. IF ANY OF THE ORIGINAL WIRE FURNISHED MUST BE REPLACED, IT MUST BE REPLACED WITH TYPE 90 C WIRE OR ITS EQUIVALENT.
2. COMPRESSOR AND FAN MOTORS ARE THERMALLY PROTECTED. THREE PHASE MOTORS ARE PROTECTED AGAINST PRIMARY SINGLE PHASING CONDITIONS.
3. 208/230V UNIT TRAN IS WIRED FOR 230V UNIT. IF UNIT IS TO BE RUN WITH 208V POWER SUPPLY DISCONNECT BLK WIRE FROM 240V TAP AND CONNECT TO 208V TAP.
4. USE COPPER CONDUCTOR ONLY.

ACCY	ACCESSORY	HS	HALL EFFECT SENSOR	OFM	OUTDOOR FAN MOTOR
AMB	AMBIENT	I	IGNITOR	OFR	OUTDOOR FAN RELAY
C	CONTACTOR, COMPRESSOR	IAQ	INDOOR AIR QUALITY SENSORS	OL	OVERLOAD
CAP	CAPACITOR	IDM	INDUCED DRAFT MOTOR	PL	PLUG ASSEMBLY
CB	CIRCUIT BREAKER	IFCB	INDOOR FAN CIRCUIT BREAKER	POT	POTENTIOMETER
CCH	CRANKCASE HEATER	IFM	INDOOR FAN MOTOR	PMR	PHASE MONITOR RELAY
CCHR	CRANKCASE HEATER RELAY	IFMC	INDOOR FAN CONTROLLER	QT	QUADRUPLE TERMINAL
CMB	COMBUSTION	IGC	INTEGRATED GAS CONTROL	RARH	RETURN AIR RELATIVE HUMIDITY
CDFS	CONDENSATE OVERFLOW SWT	JMP	JUMPER	RAT	RETURN AIR TEMP. SENSOR
COMP	COMPRESSOR MOTOR	LA	LOW AMBIENT	RDV	REHEAT DISCHARGE VALVE
DDC	DIRECT DIGITAL CONTROL	LDV	LIQUID DIVERTER VALVE	RS	ROLLOUT SWITCH
ERV	ENERGY RECOVERY VENTILATOR	LPS	LOW PRESSURE SWITCH	SAT	SUPPLY AIR TEMP. SENSOR
FIOP	FACTORY INSTALLED OPTION	LSM	LIMIT SWITCH (MANUAL RESET)	SEN	SENSOR
FLS	FAN LIMIT SWITCH	LS	LIMIT SWITCH	SPRH	SPACE RELATIVE HUMIDITY
FPT	FREEZE PROTECTION THERMOSTAT	LTLO	LOW TEMPERATURE LOCKOUT	SPT	SPACE TEMPERATURE SENSOR
FSD	FIRE SHUT DOWN	MV	MAIN GAS VALVE	SPTO	SPACE TEMPERATURE OFFSET
FS	FLAME SENSOR	MOV	VOLTAGE RESTRICTOR	STD	STANDARD
FU	FUSE	MTR	MOTOR	TB	TERMINAL BLOCK
GND	GROUND	MTS	MIXED AIR TEMPERATURE SWITCH	TDR	TIME DELAY RELAY (WINTER START)
GVR	GAS VALVE RELAY	OAO	OUTDOOR AIR QUALITY	TRAN	TRANSFORMER
HPC	HEAD PRESSURE CONTROL	OARH	OUTSIDE AIR RELATIVE HUMIDITY	UCB	UNIT CONTROL BOARD
HPS	HIGH PRESSURE SWITCH	OAT	OUTDOOR AIR TEMP. SENSOR		

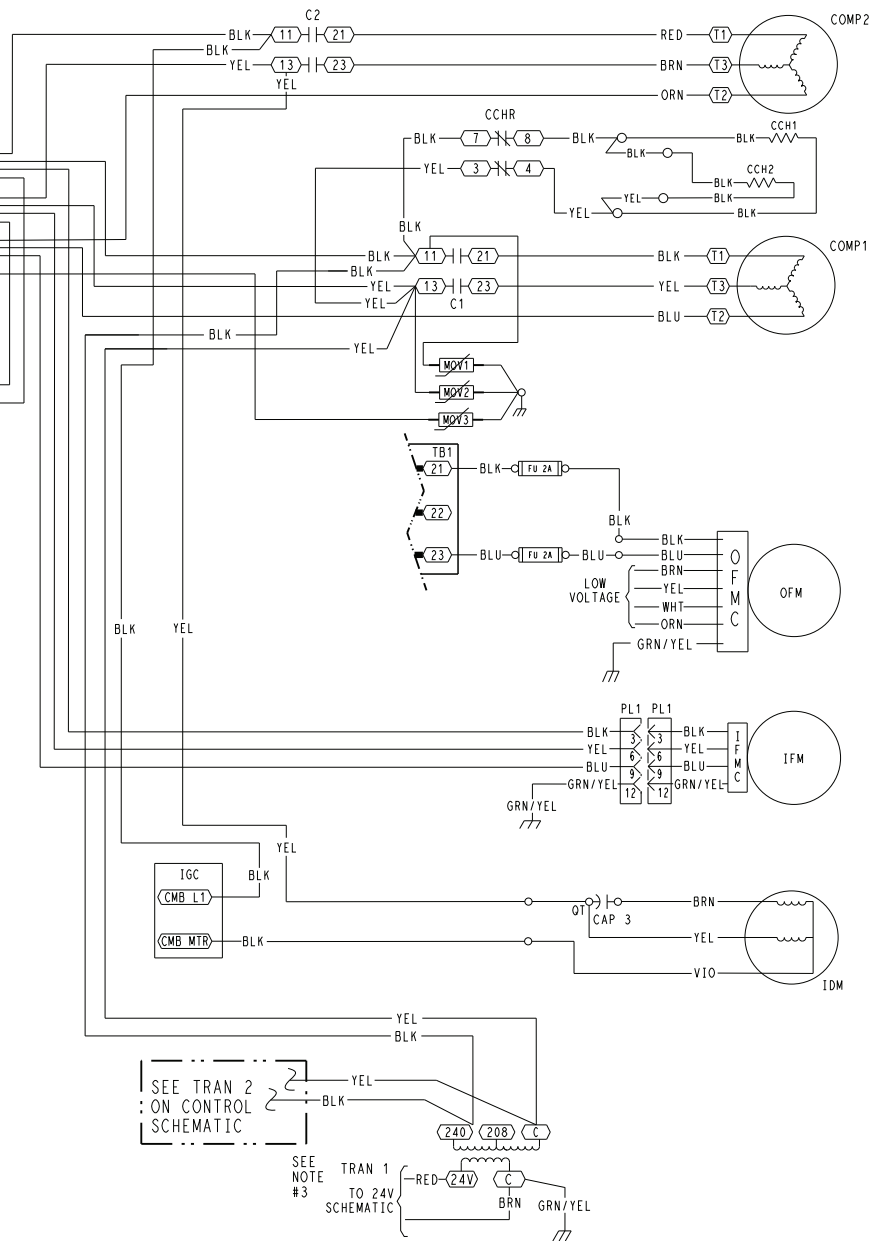

48TM005991 B

### Typical Control Wiring Diagram — 48FC 16 230/460/575-3-60 Unit with Electro-Mechanical Controller

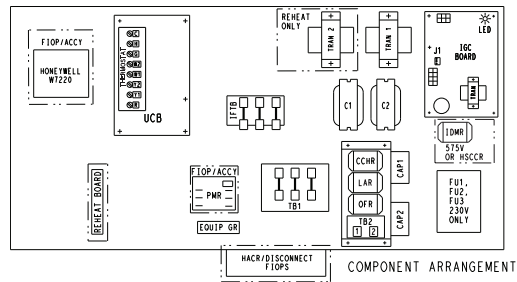

- NOTES:**
1. UCB SCHEMATIC LAYOUT DOES NOT MATCH ACTUAL TERMINAL BOARD LAYOUT.
  2. TERMINAL BOARD JUMPERS 1, 2 AND 3 ARE CUT FOR REHEAT UNITS ONLY.
  3. REMOVE DESIGNATED JUMPERS ON UCB WHEN ADDING SMOKE DETECTORS, OCCUPANCY AND REMOTE SHUTDOWN.
  4. USE ABC AS COARSE AND POT AS FINE ADJUSTMENTS FOR SETTING HIGH FAN SPEED. LOW SPEED IS AN OFFSET BASED ON DIP SWITCHES.
  5. 2-PIN LOW SPEED DIP SWITCH POSITIONS ARE FACTORY SET AS SHOWN.
  6. HARDCUT AND CUTOFF SET TO "MIN". JUMPER PIN ON TOP 2-PINS AS SHOWN.
  7. THE \* WIRE COLOR IS FOR DIFFERENTIATION WITHIN THIS SCHEMATIC.
  8. IGC P3 SETTING: 30 SEC.
  9. TRANSFORMER IS DEDICATED BASED ON UNIT VOLTAGE. TAPS ONLY SHOWN TO SIMPLIFY SCHEMATIC. 208/230V UNIT TRAN IS WIRED FOR 230V UNIT. IF UNIT IS TO BE RUN WITH 208V POWER SUPPLY DISCONNECT BLK WIRE FROM 230V TAP AND CONNECT TO 208V TAP.

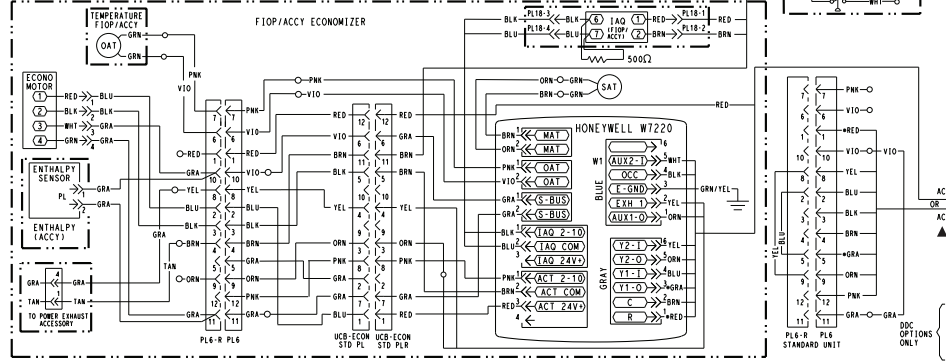
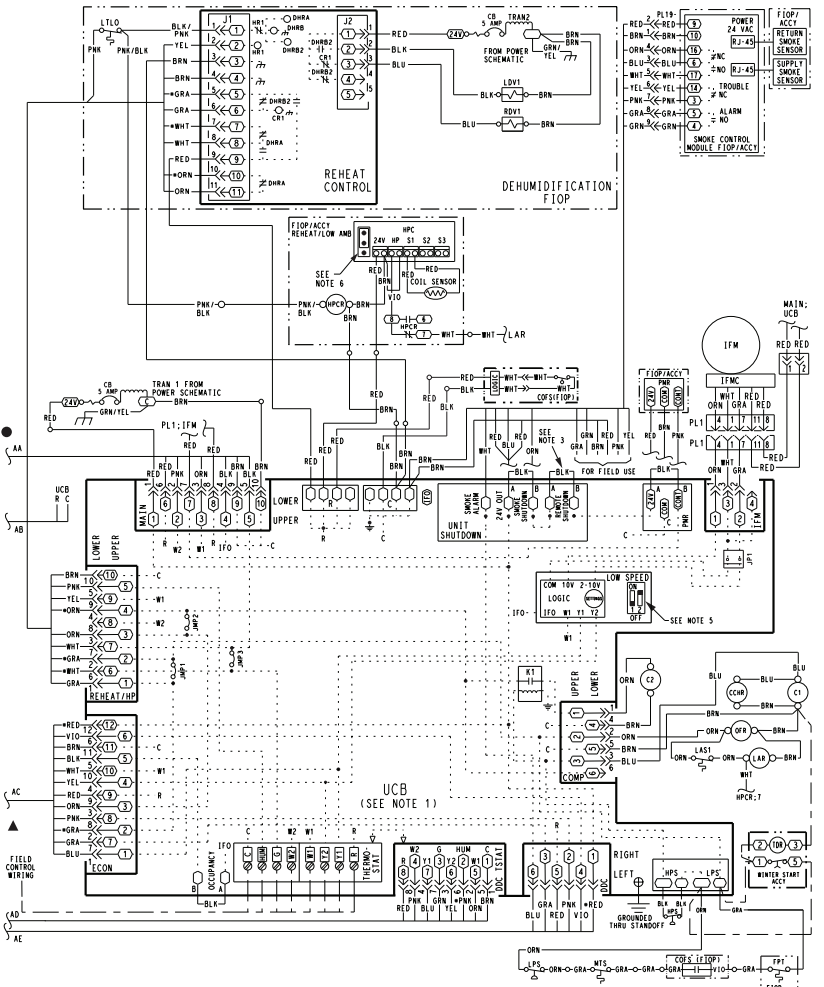
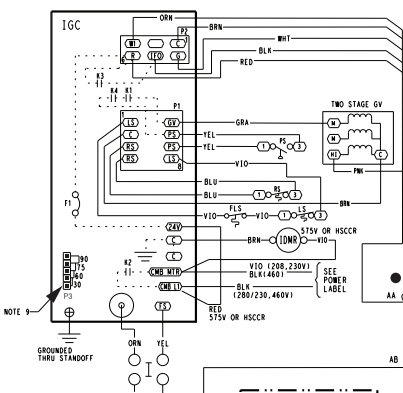
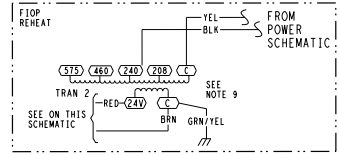

YAC CONTROL 230/460/575V T1 15 TON  
50T00019111 B





## Typical Control Wiring Diagram — 48FC 16 230/460/575-3-60 Unit with systemvu™ Controller

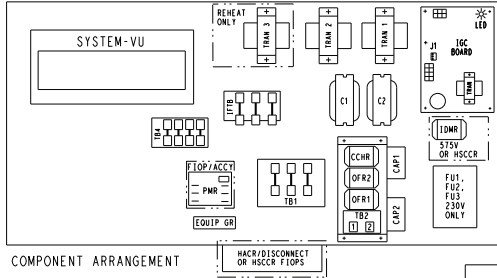

- NOTES:
1. LOW VOLTAGE CONNECTIONS MUST BE CLASS 2.
  2. USB-B AT J4 AND ETHERNETS AT J13, J14 ARE SHOWN FOR FUTURE USE.
  3. THE "Y3" TERMINAL IS CONFIGURABLE IN THE SOFTWARE.
  4. HARDSTART AND CUTOFF SET TO "MIN". JUMPER PIN ON TOP 2-PINS AS SHOWN.
  5. WHEN USING A RARH SENSOR, MAKE CONNECTION IN THE RETURN AIR SECTION.
  6. WHEN USING A SPRH SENSOR, MAKE CONNECTION HERE BY DISCONNECTING YELLOW WIRE.
  7. IGC P3 SETTING: 30 SEC.
  8. DISCONNECT V10 TO ALLOW POWER EXHAUST CONNECTION.
  9. TRANSFORMER IS DEDICATED BASED ON UNIT VOLTAGE. TAPS ONLY SHOWN TO SIMPLIFY SCHEMATIC. 208/230V UNIT TRAN IS WIRED FOR 230V UNIT. IF UNIT IS TO BE RUN WITH 208V POWER SUPPLY DISCONNECT BLK WIRE FROM 230V TAP AND CONNECT TO 208V TAP.

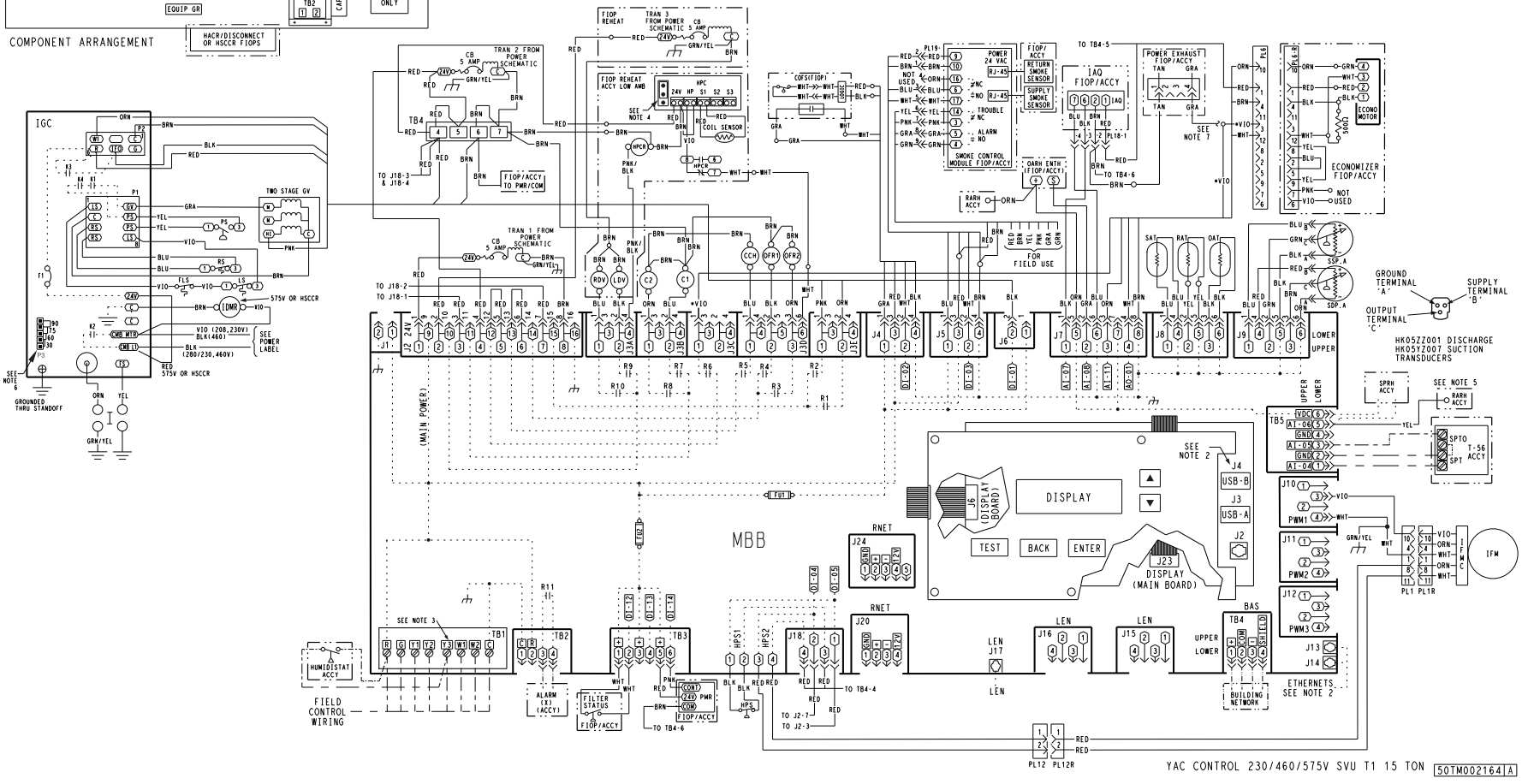
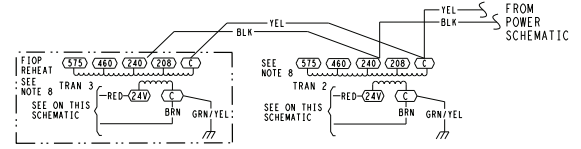

YAC CONTROL 230/460/575V SVU T1 15 TON [50TM002164]A



## Typical Power Wiring Diagram — 48FC 16 208-230/460-3-60 Unit with Electro-Mechanical or SystemVu™ Controllers

YAC POWER 208/230, 460V T1 15 TON

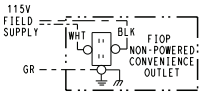
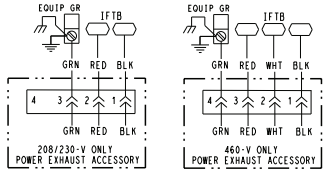
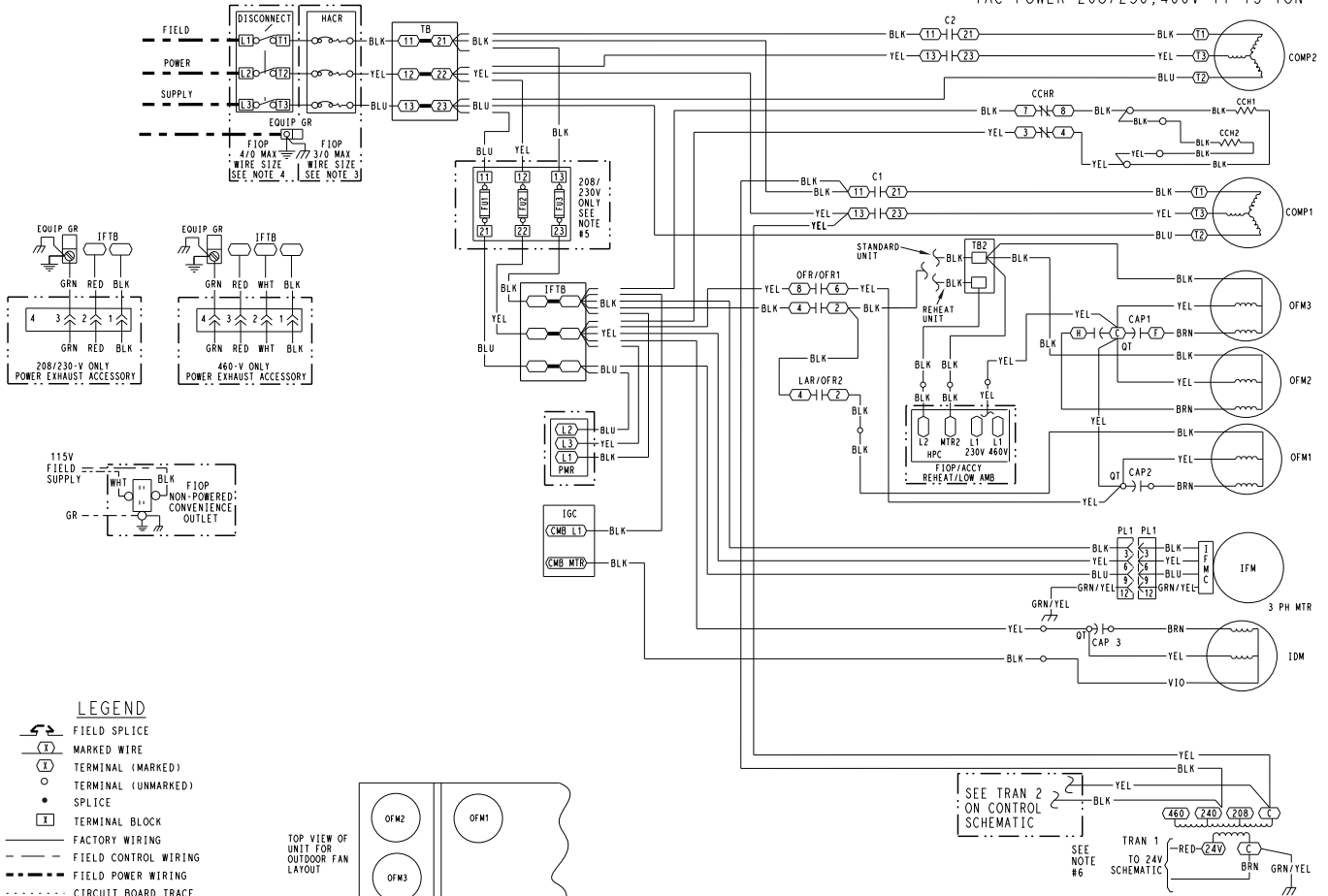

- LEGEND**
- FIELD SPLICE
  - MARKED WIRE
  - TERMINAL (MARKED)
  - TERMINAL (UNMARKED)
  - SPLICE
  - TERMINAL BLOCK
  - FACTORY WIRING
  - FIELD CONTROL WIRING
  - FIELD POWER WIRING
  - CIRCUIT BOARD TRACE
  - ACCESSORY OR FIOP
  - TO INDICATE COMMON POTENTIAL ONLY: NOT TO REPRESENT WIRING

TOP VIEW OF UNIT FOR OUTDOOR FAN LAYOUT

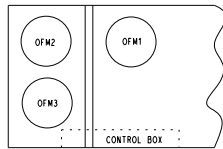

- NOTES:**
1. IF ANY OF THE ORIGINAL WIRE FURNISHED MUST BE REPLACED, IT MUST BE REPLACED WITH TYPE 90 C WIRE OR ITS EQUIVALENT.
  2. COMPRESSOR AND FAN MOTORS ARE THERMALLY PROTECTED. THREE PHASE MOTORS ARE PROTECTED AGAINST PRIMARY SINGLE PHASING CONDITIONS.
  3. USE COPPER, COPPER CLAD ALUMINUM OR ALUMINUM CONDUCTORS.
  4. USE COPPER CONDUCTORS ONLY.
  5. F01, F02, AND F03, REPLACE WITH 250V 60A BUSSMAN FRNR 60.
  6. TRANSFORMER IS DEDICATED BASED ON UNIT VOLTAGE. TAPS ONLY SHOWN TO SIMPLIFY SCHEMATIC. 208/230V UNIT TRAW IS WIRED FOR 230V UNIT. IF UNIT IS TO BE RUN WITH 208V POWER SUPPLY DISCONNECT BLK WIRE FROM 230V TAP AND CONNECT TO 200V TAP.

ACCY	ACCESSORY	HS	HALL EFFECT SENSOR	OFM	OUTDOOR FAN MOTOR
AMB	AMBIENT	I	IGNITOR	OFRL	OUTDOOR FAN RELAY
C	CONTACTOR/COMPRESSOR	IAQ	INDOOR AIR QUALITY SENSORS	OL	OVERLOAD
CAP	CAPACITOR	IDM	INDUCED DRAFT MOTOR	PL	PLUG ASSEMBLY
CB	CIRCUIT BREAKER	IFCB	INDOOR FAN CIRCUIT BREAKER	POT	POTENTIOMETER
CCH	CRANKCASE HEATER	IFM	INDOOR FAN MOTOR	PMR	PHASE MONITOR RELAY
CCHR	CRANKCASE HEATER RELAY	IFMC	INDOOR FAN CONTROLLER	QT	QUADRUPLE TERMINAL
CMB	COMBUSTION	IGC	INTEGRATED GAS CONTROL	RARH	RETURN AIR RELATIVE HUMIDITY
COFS	CONDENSATE OVERFLOW SWT	JMP	JUMPER	RAT	RETURN AIR TEMP. SENSOR
COMP	COMPRESSOR MOTOR	LA	LOW AMBIENT	RDV	REHEAT DISCHARGE VALVE
DDC	DIRECT DIGITAL CONTROL	LQV	LIQUID DIVERTER VALVE	RS	ROLLOUT SWITCH
ERV	ENERGY RECOVERY VENTILATOR	LPS	LOW PRESSURE SWITCH	SAT	SUPPLY AIR TEMP. SENSOR
FIOP	FACTORY INSTALLED OPTION	LSM	LIMIT SWITCH (MANUAL RESET)	SEN	SENSOR
FLS	FAN LIMIT SWITCH	LS	LIMIT SWITCH	SPRH	SPACE RELATIVE HUMIDITY
FPT	FREEZE PROTECTION THERMOSTAT	LTO	LOW TEMPERATURE LOCKOUT	SPT	SPACE TEMPERATURE SENSOR
FSD	FIRE SHUT DOWN	MGV	MAIN GAS VALVE	SPTO	SPACE TEMPERATURE OFFSET
FS	FLAME SENSOR	MOV	VOLTAGE RESTRICTOR	STD	STANDARD
FU	FUSE	MTR	MOTOR	STD	STANDARD
GND	GROUND	MTS	MIXED AIR TEMPERATURE SWITCH	TB	TERMINAL BLOCK
GVR	GAS VALVE RELAY	OAO	OUTDOOR AIR QUALITY	TDR	TIME DELAY RELAY (WINTER START)
HPC	HEAD PRESSURE CONTROL	OARH	OUTSIDE AIR RELATIVE HUMIDITY	UCB	UNIT CONTROL BOARD
HPS	HIGH PRESSURE SWITCH	OAT	OUTDOOR AIR TEMP. SENSOR		

50TM001914 A

## Typical Power Wiring Diagram — 48FC 16 575-3-60 Unit with Electro-Mechanical or SystemVu™ Controllers

YAC POWER 575V T1 15 TON

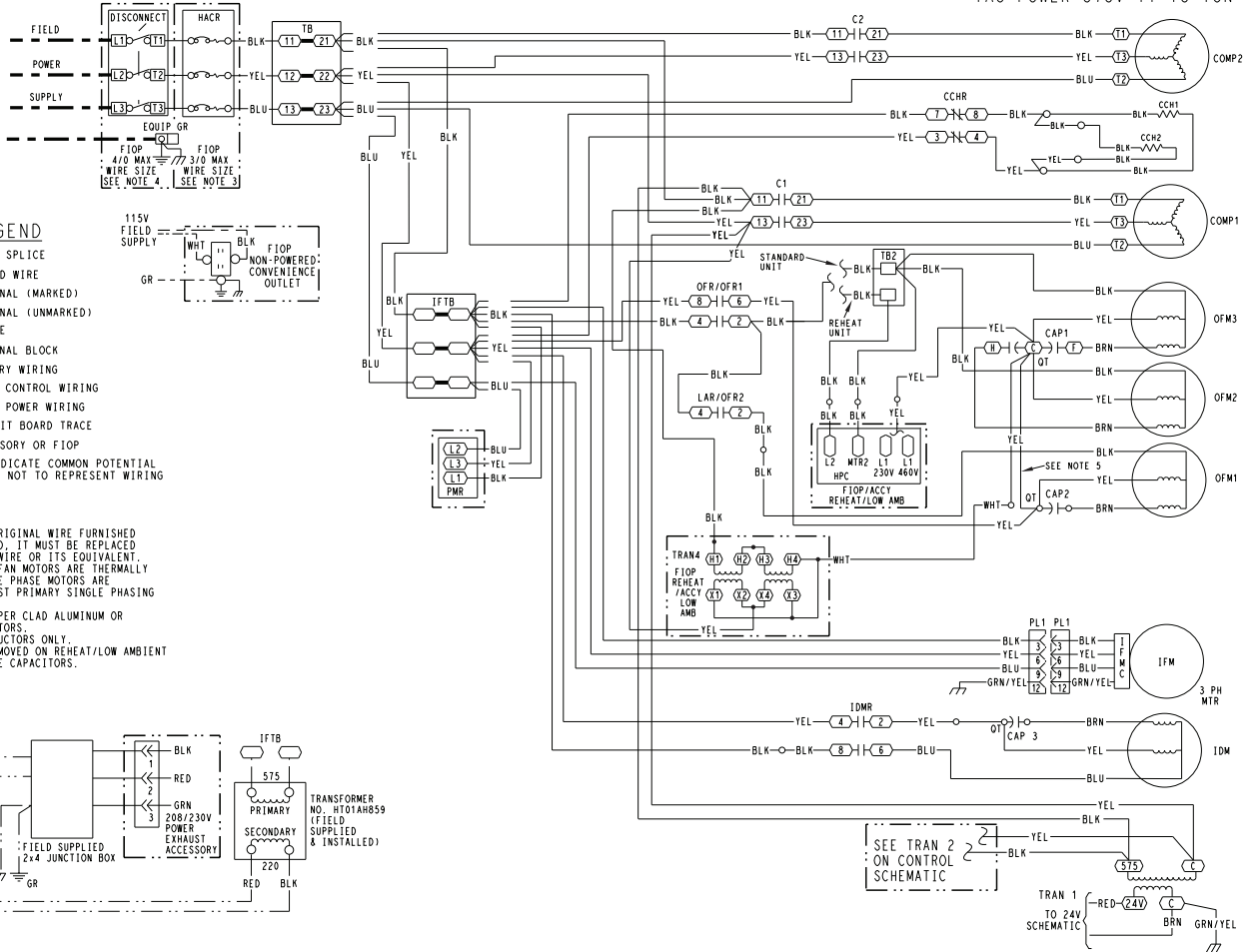

**NOTES:**

1. IF ANY OF THE ORIGINAL WIRE FURNISHED MUST BE REPLACED, IT MUST BE REPLACED WITH TYPE 90 C WIRE OR ITS EQUIVALENT.
2. COMPRESSOR AND FAN MOTORS ARE THERMALLY PROTECTED. THREE PHASE MOTORS ARE PROTECTED AGAINST PRIMARY SINGLE PHASING CONDITIONS.
3. USE COPPER, COPPER CLAD ALUMINUM OR ALUMINUM CONDUCTORS.
4. USE COPPER CONDUCTORS ONLY.
5. THIS WIRE IS REMOVED ON REHEAT/LOW AMBIENT UNITS TO ISOLATE CAPACITORS.

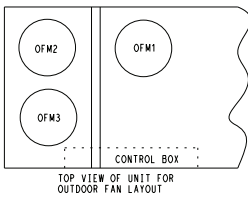

ACCY	ACCESSORY	HS	HALL EFFECT SENSOR	OFM	OUTDOOR FAN MOTOR
AMB	AMBIENT	I	IGNITOR	OFR	OUTDOOR FAN RELAY
C	CONTACTOR, COMPRESSOR	IAQ	INDOOR AIR QUALITY SENSORS	OL	OVERLOAD
CAP	CAPACITOR	IDM	INDUCED DRAFT MOTOR	PL	PLUG ASSEMBLY
CB	CIRCUIT BREAKER	IFCB	INDOOR FAN CIRCUIT BREAKER	POT	POTENTIOMETER
CCH	CRANKCASE HEATER	IFM	INDOOR FAN MOTOR	PMR	PHASE MONITOR RELAY
CCHR	CRANKCASE HEATER RELAY	IFMC	INDOOR FAN CONTROLLER	QT	QUADRUPLY TERMINAL
CMB	COMBUSTION	IGC	INTEGRATED GAS CONTROL	RARH	RETURN AIR RELATIVE HUMIDITY
COFS	CONDENSATE OVERFLOW SWT	JMP	JUMPER	RAT	RETURN AIR TEMP. SENSOR
COMP	COMPRESSOR MOTOR	LA	LOW AMBIENT	RDV	REHEAT DISCHARGE VALVE
DDC	DIRECT DIGITAL CONTROL	LDV	LIQUID DIVERTER VALVE	RS	ROLL-OUT SWITCH
ERV	ENERGY RECOVERY VENTILATOR	LPS	LOW PRESSURE SWITCH	SAT	SUPPLY AIR TEMP. SENSOR
F1OP	FACTORY INSTALLED OPTION	LSM	LIMIT SWITCH (MANUAL RESET)	SEN	SENSOR
FLS	FAN LIMIT SWITCH	LS	LIMIT SWITCH	SPRH	SPACE RELATIVE HUMIDITY
FPT	FREEZE PROTECTION THERMOSTAT	LFLQ	LOW TEMPERATURE LOCKOUT	SPT	SPACE TEMPERATURE SENSOR
FSD	FIRE SHUT DOWN	LGS	MAIN GAS VALVE	SPTO	SPACE TEMPERATURE OFFSET
FS	FLAME SENSOR	MOV	VOLTAGE RESTRICTOR	STD	STANDARD
FU	FUSE	MTR	MOTOR	TB	TERMINAL BLOCK
GND	GROUND	MTS	MIXED AIR TEMPERATURE SWITCH	TDR	TIME DELAY RELAY (WINTER START)
GVR	GAS VALVE RELAY	OARH	OUTDOOR AIR QUALITY	TRAN	TRANSFORMER
HPC	HEAD PRESSURE CONTROL	OAT	OUTSIDE AIR RELATIVE HUMIDITY	UCB	UNIT CONTROL BOARD
HPS	HIGH PRESSURE SWITCH				

50TM001916 | A

### Typical Control Wiring Diagram — 50FC 08-12 208-230/460/575-3-60 Unit with Electro-Mechanical Control and W7220 Economizer

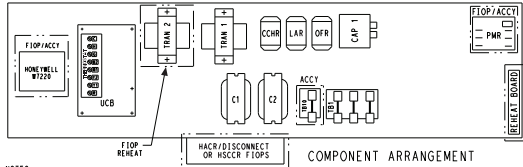

- NOTES:
1. TERMINAL BOARD SCHEMATIC LAYOUT DOES NOT MATCH ACTUAL TERMINAL BOARD LAYOUT.
  2. TERMINAL BOARD JUMPERS 1, 2 AND 3 ARE CUT FOR REHEAT UNITS ONLY.
  3. REMOVE DESIGNATED JUMPERS ON TERMINAL BOARD WHEN ADDING SMOKE DETECTORS, OCCUPANCY AND REMOTE SHUTDOWN.
  4. USE ABC AS COARSE AND POT AS FINE ADJUSTMENTS FOR SETTING HIGH FAN SPEED. LOW SPEED IS AN OFFSET BASED ON DIP SWITCHES.
  5. 2-PIN LOW SPEED DIP SWITCH POSITIONS ARE FACTORY SET AS SHOWN. EXCEPTION ON 8.5 TON UNITS, THESE ARE SET TO "ON-OFF".
  6. HANDSTART AND CUTOFF SET TO "MIN". JUMPER PIN ON TOP 2-PINS AS SHOWN.
  7. THE \* WIRE COLOR IS FOR DIFFERENTIATION WITHIN THIS SCHEMATIC.
  8. TRANSFORMER IS DEDICATED BASED ON UNIT VOLTAGE. TAPS ONLY SHOWN TO SIMPLIFY SCHEMATIC. 208/230V UNIT TRANS IS WIRED FOR 230V UNIT. IF UNIT IS TO BE RUN WITH 208V POWER SUPPLY DISCONNECT BLK WIRE FROM 230V TAP AND CONNECT TO 200V TAP.
  9. TB4 LOCATED IN HEAT SECTION.
  10. TO CONVERT TO A SINGLE STAGE HEATER MOVE VIOLET WIRE AT TB4 TO CONNECT WITH WHITE WIRE.

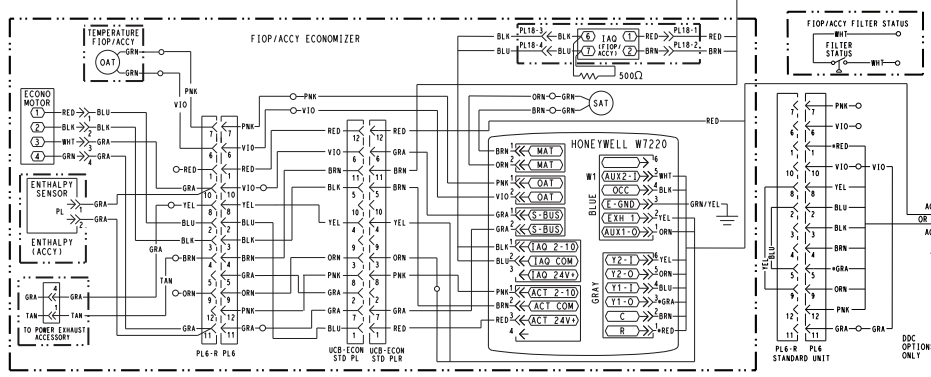
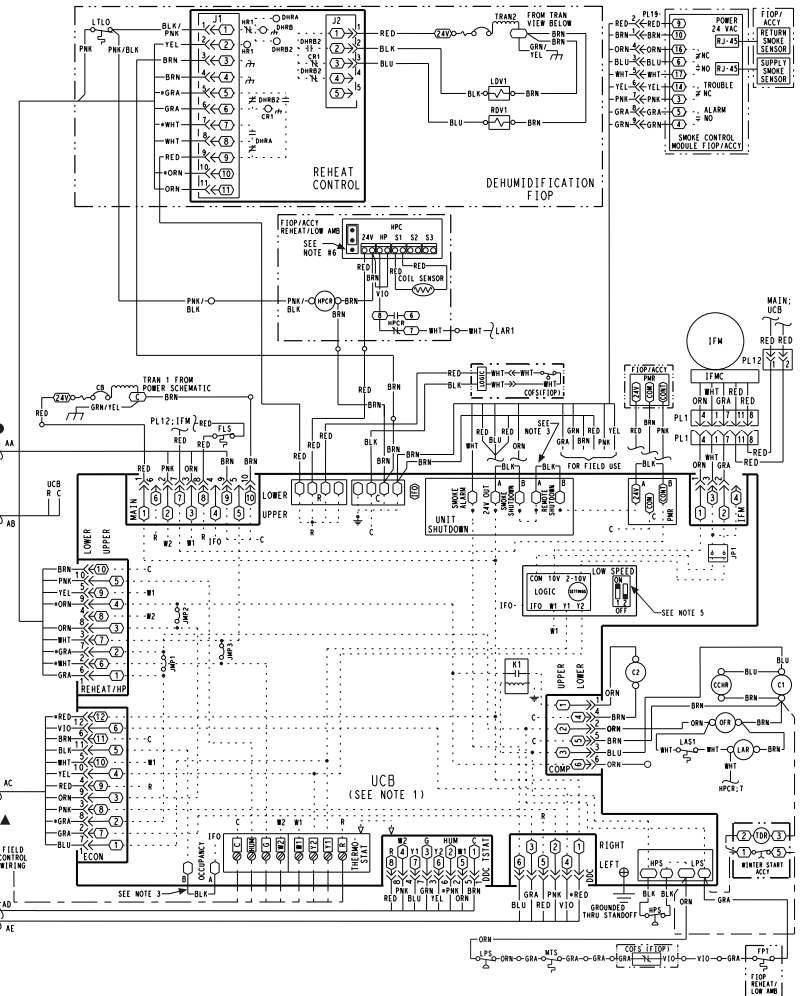
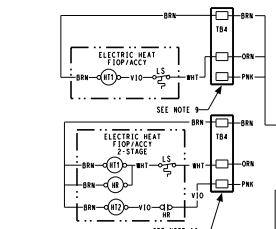
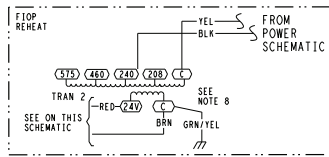

PAC CONTROL 230/460/575V T1 7.5-10 TON

48TMO05715 I C



## Typical Control Wiring Diagram — 50FC 08-12 208-230/460/575-3-60 Unit with SystemVu™ Controller

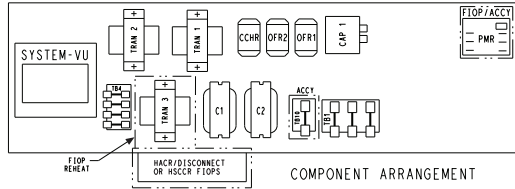

- NOTES:
1. LOW VOLTAGE CONNECTIONS MUST BE CLASS 2.
  2. USB-B AT J4 AND ETHERNETS AT J13, J14 ARE SHOWN FOR FUTURE USE.
  3. THE \*13\* TERMINAL IS CONFIGURABLE IN THE SOFTWARE.
  4. HARDSTART AND CUTOFF SET TO "MIN". JUMPER PIN ON TOP 2-PINS AS SHOWN.
  5. WHEN USING A BARH SENSOR, MAKE CONNECTION IN THE RETURN AIR SECTION. WHEN USING SPRN SENSOR, MAKE CONNECTION HERE BY DISCONNECTING YELLOW WIRE.
  6. TB2 LOCATED IN HEAT SECTION.
  7. TO CONVERT TO A SINGLE STAGE HEATER MOVE VIOLET WIRE AT TB4 TO CONNECT WITH WHITE WIRE.
  8. DISCONNECT VIO TO ALLOW POWER EXHAUST CONNECTION.
  9. TRANSFORMER IS DEDICATED BASED ON UNIT VOLTAGE. TAPS ONLY SHOWN TO SIMPLIFY SCHEMATIC. 208/230V UNIT TRAN IS WIRED FOR 230V UNIT. IF UNIT IS TO BE RUN WITH 208V POWER SUPPLY DISCONNECT BLK WIRE FROM 230V TAP AND CONNECT TO 200V TAP.

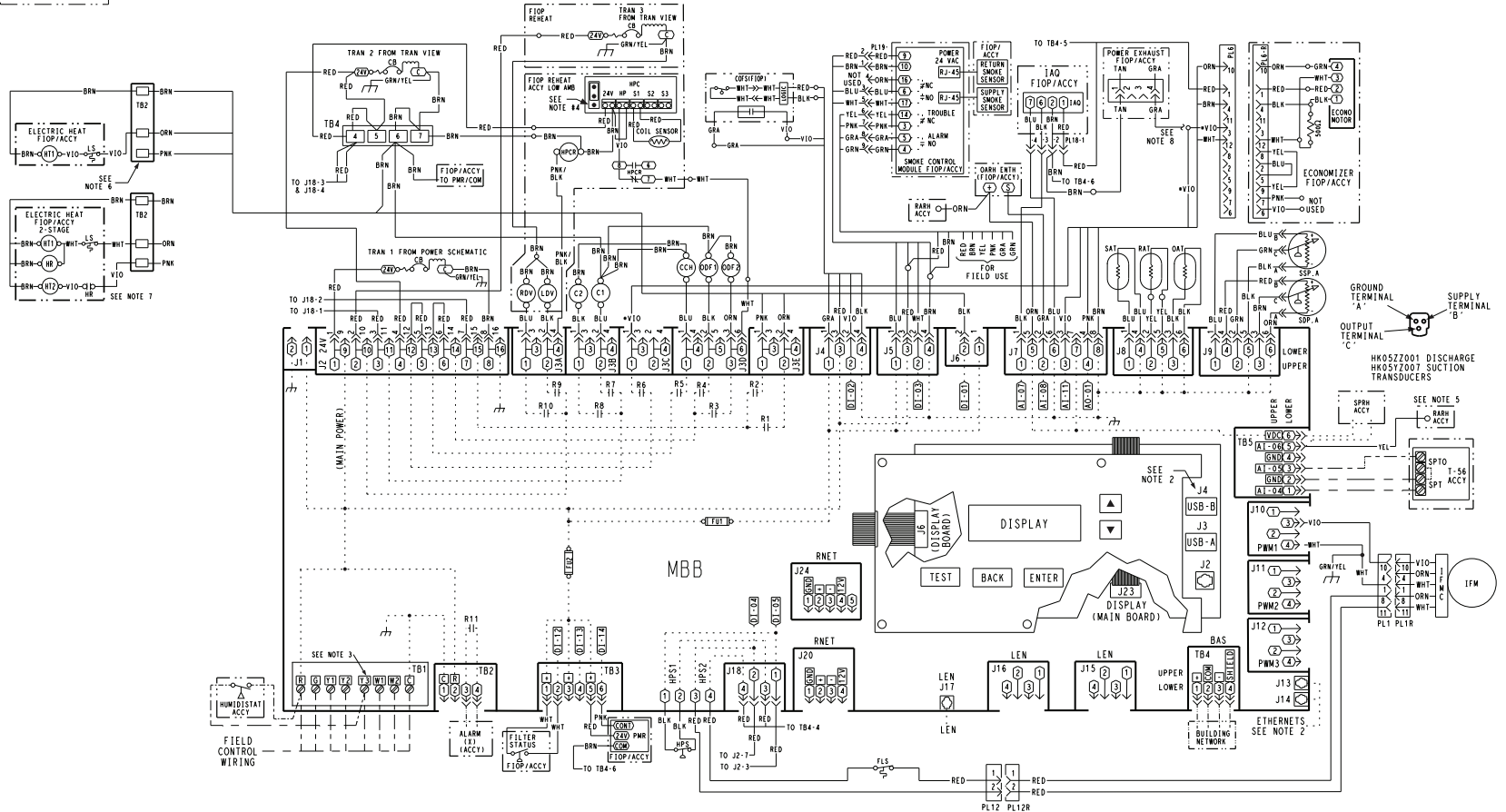
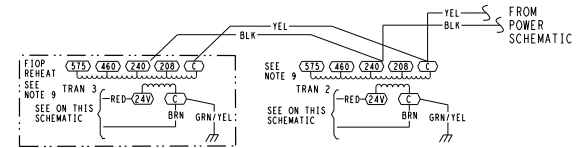

PAC CONTROL 230/460/575V SVU T1 7.5-10 TON 48TM006352 B



## Typical Power Wiring Diagram — 50FC 08-12 208-230/460-3-60 Unit with Electro-Mechanical or SystemVu™ Controllers

PAC POWER 230/460V T1 7.5-10 TON  
HP POWER 230/460V T1 7.5-8.5 TON

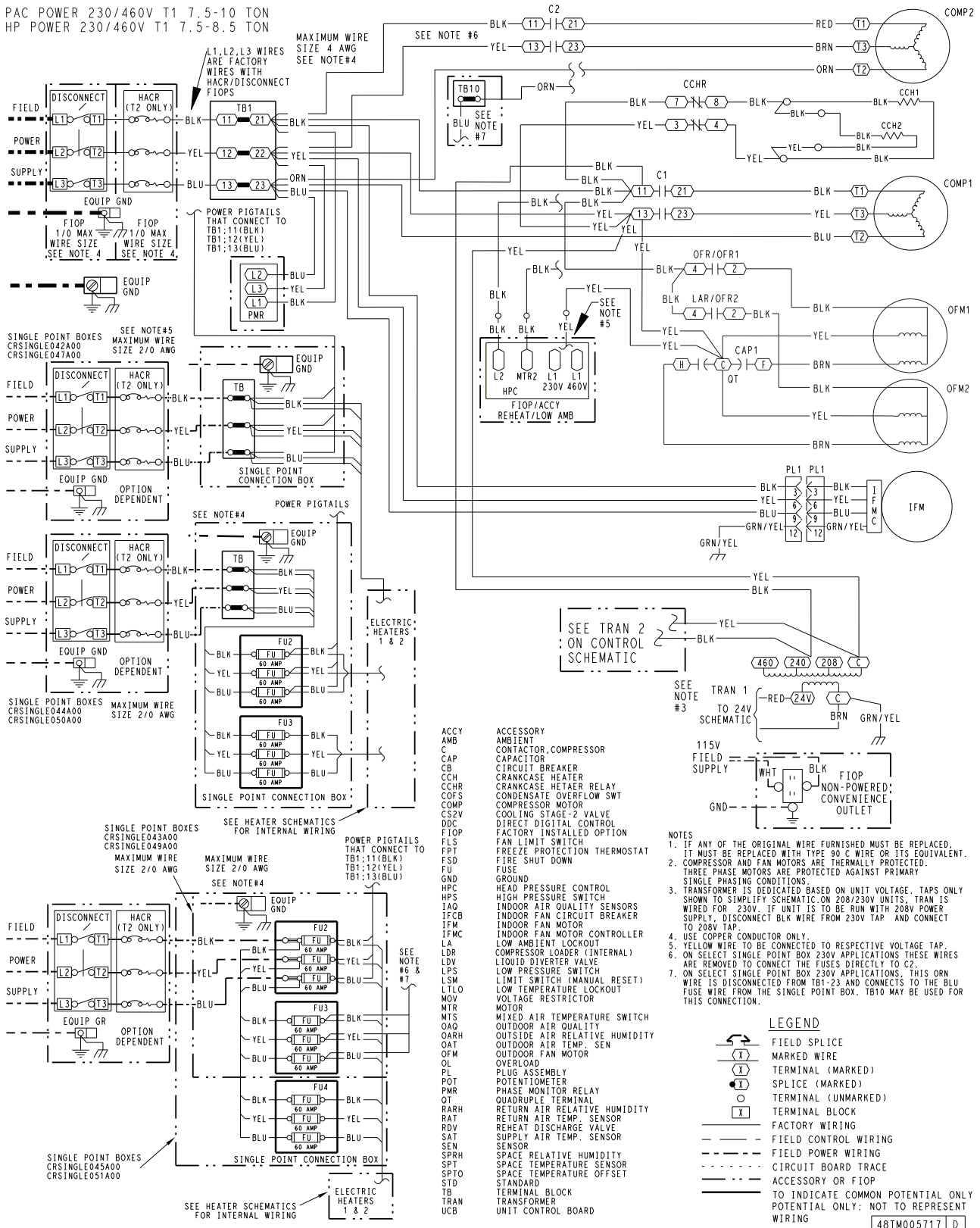

- ACCY ACCY
- AMB AMBIENT
- C CONTACTOR-COMPRESSOR
- CAP CAPACITOR
- CB CIRCUIT BREAKER
- CCH CRANKCASE HEATER
- CCHR CRANKCASE HEATER RELAY
- CCH2 CRANKCASE HEATER RELAY
- CCH1 CRANKCASE HEATER RELAY
- COFS CONDENSATE OVERFLOW SWT
- COMP COMPRESSOR MOTOR
- CS2V COOLING STAGE-2 VALVE
- DDC DIRECT DIGITAL CONTROL
- FAN FAN LIMIT SWITCH
- FLS FREEZE PROTECTION THERMOSTAT
- FSD FIRE SHUT DOWN
- FUSE FUSE
- GND GROUND
- HPC HEAD PRESSURE CONTROL
- HPS HIGH PRESSURE SWITCH
- IAQ INDOOR AIR QUALITY SENSORS
- IFCB INDOOR FAN CIRCUIT BREAKER
- IFM INDOOR FAN MOTOR
- IFMC INDOOR FAN MOTOR CONTROLLER
- LA LOW AMBIENT LOCKOUT
- LDR COMPRESSOR LOADER (INTERNAL)
- LQV LIQUID DIVERTER VALVE
- LPS LOW PRESSURE SWITCH
- LSM LIMIT SWITCH (MANUAL RESET)
- LTLO LOW TEMPERATURE LOCKOUT
- MOV VOLTAGE RESTRICTOR
- MTR MOTOR
- MTS MIXED AIR TEMPERATURE SWITCH
- OAQ OUTDOOR AIR QUALITY
- OARH OUTSIDE AIR RELATIVE HUMIDITY
- OAT OUTDOOR AIR TEMP. SEN
- OFM OUTDOOR FAN MOTOR
- OVERL OVERLOAD
- PL PLUS ASSEMBLY
- POT POTENTIOMETER
- PMR PHASE MONITOR RELAY
- QT QUADRUPLE TERMINAL
- RARH RETURN AIR RELATIVE HUMIDITY
- RAT RETURN AIR TEMP. SENSOR
- RDV REHEAT DISCHARGE VALVE
- SAT SUPPLY AIR TEMP. SENSOR
- SEN SENSOR
- SPRH SPACE RELATIVE HUMIDITY
- SPT SPACE TEMPERATURE SENSOR
- SPTO SPACE TEMPERATURE OFFSET
- STD STANDARD
- TB TERMINAL BLOCK
- TRAN TRANSFORMER
- UCB UNIT CONTROL BOARD

- NOTES**
- IF ANY OF THE ORIGINAL WIRE FURNISHED MUST BE REPLACED, IT MUST BE REPLACED WITH TYPE 90 C WIRE OR ITS EQUIVALENT.
  - COMPRESSOR AND FAN MOTORS ARE THERMALLY PROTECTED. THREE PHASE MOTORS ARE PROTECTED AGAINST PRIMARY SINGLE PHASING CONDITIONS.
  - TRANSFORMER IS DEDICATED BASED ON UNIT VOLTAGE. TAPS ONLY SHOWN TO SIMPLIFY SCHEMATIC ON 208/230V UNITS, TRAN IS WIRED FOR 230V. IF UNIT IS TO BE RUN WITH 208V POWER SUPPLY, DISCONNECT BLK WIRE FROM 230V TAP AND CONNECT TO 208V TAP.
  - USE COPPER CONDUCTOR ONLY.
  - YELLOW WIRE TO BE CONNECTED TO RESPECTIVE VOLTAGE TAP.
  - ON SELECT SINGLE POINT BOX 230V APPLICATIONS THESE WIRES ARE REMOVED TO CONNECT THE FUSES DIRECTLY TO C2.
  - ON SELECT SINGLE POINT BOX 230V APPLICATIONS, THIS ORN WIRE IS DISCONNECTED FROM TB1-23 AND CONNECTS TO THE BLU WIRE FROM THE SINGLE POINT BOX. TB10 MAY BE USED FOR THIS CONNECTION.

48TM005717 D

## Typical Control Wiring Diagram — 50FC 14 208-230/460/575-3-60 Unit with Electro-Mechanical Control and W7220 Economizer

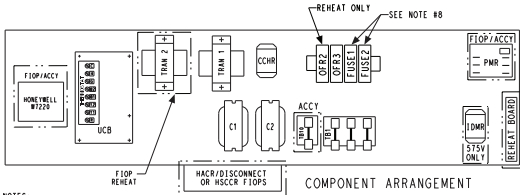

- NOTES:**
1. UCB SCHEMATIC LAYOUT DOES NOT MATCH ACTUAL TERMINAL BOARD LAYOUT.
  2. TERMINAL BOARD JUMPERS 1, 2 AND 3 ARE CUT FOR REHEAT UNITS ONLY.
  3. REMOVE DESIGNATED JUMPERS ON UCB WHEN ADDING SMOKE DETECTORS, OCCUPANCY AND REMOTE SHUTDOWN.
  4. USE ABC AS COARSE AND POT AS FINE ADJUSTMENTS FOR SETTING HIGH FAN SPEED. LOW SPEED IS AN OFFSET BASED ON DIP SWITCHES.

5. 2-PIN LOW SPEED DIP SWITCH POSITIONS ARE FACTORY SET AS SHOWN.
6. HARDSTART AND CUTOFF SET TO "MIN". JUMPER PIN ON TOP 2-PINS AS SHOWN.
7. THE \* WIRE COLOR IS FOR DIFFERENTIATION WITHIN THIS SCHEMATIC.
8. FUSES FOR 230V ARE LOCATED IN CONTROL BOX. FUSES FOR 460/575V ARE LOCATED BELOW THE CONTROL BOX.
9. T84 LOCATED IN HEAT SECTION.
10. TO CONVERT TO A SINGLE STAGE HEATER MOVE VIOLET WIRE AT T84 TO CONNECT WITH WHITE WIRE.
11. TRANSFORMER IS SPECIFICATED BASED ON UNIT VOLTAGE. TAPS ONLY SHOWN TO SIMPLIFY SCHEMATIC. 208/230V UNIT TRAN IS WIRED FOR 230V UNIT. IF UNIT IS TO BE RUN WITH 208V POWER SUPPLY DISCONNECT BLK WIRE FROM 230V TAP AND CONNECT TO 200V TAP.

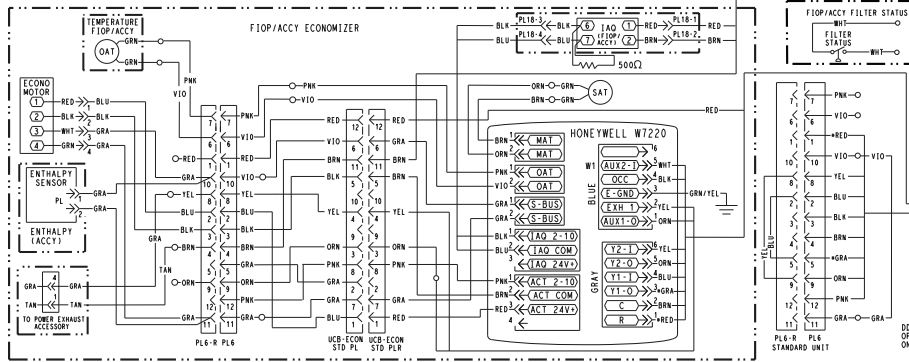
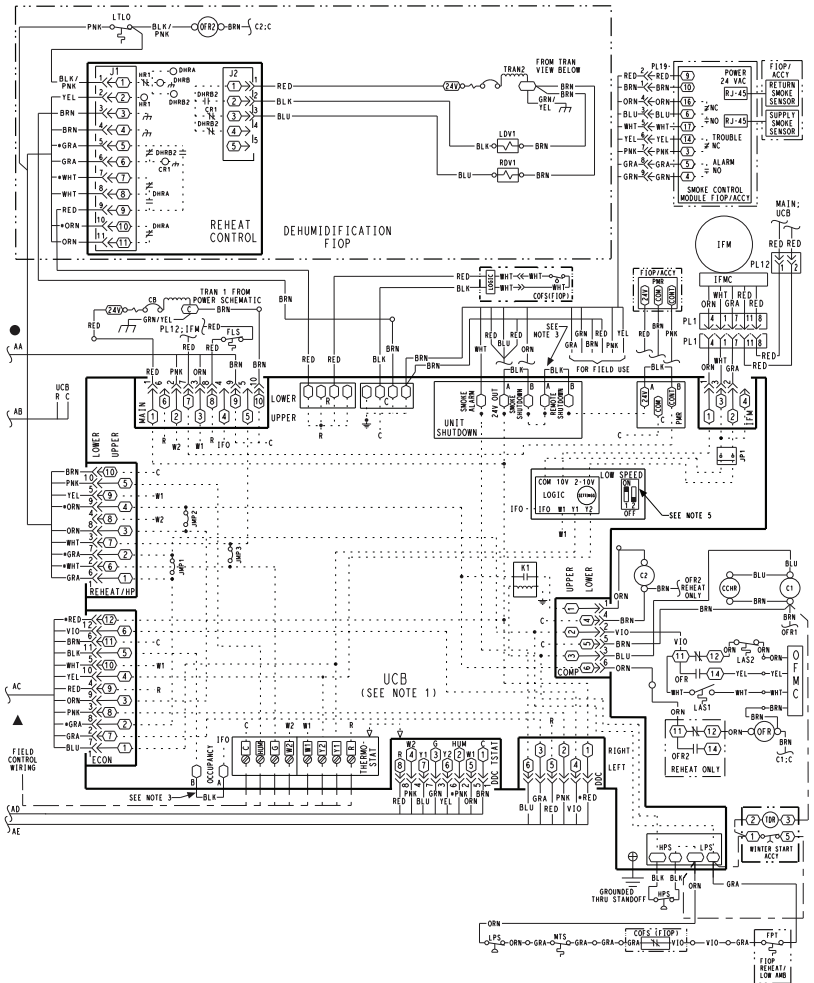
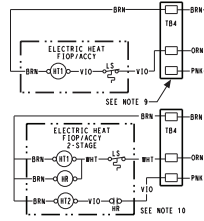
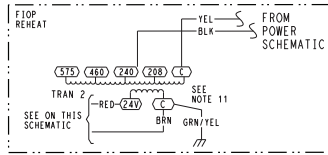

PAC CONTROL 230/460/575V T1 12.5 TON 48TM005985 C



## Typical Power Wiring Diagram — 50FC 14 208-230/3/60 Unit with Electro-Mechanical Controller

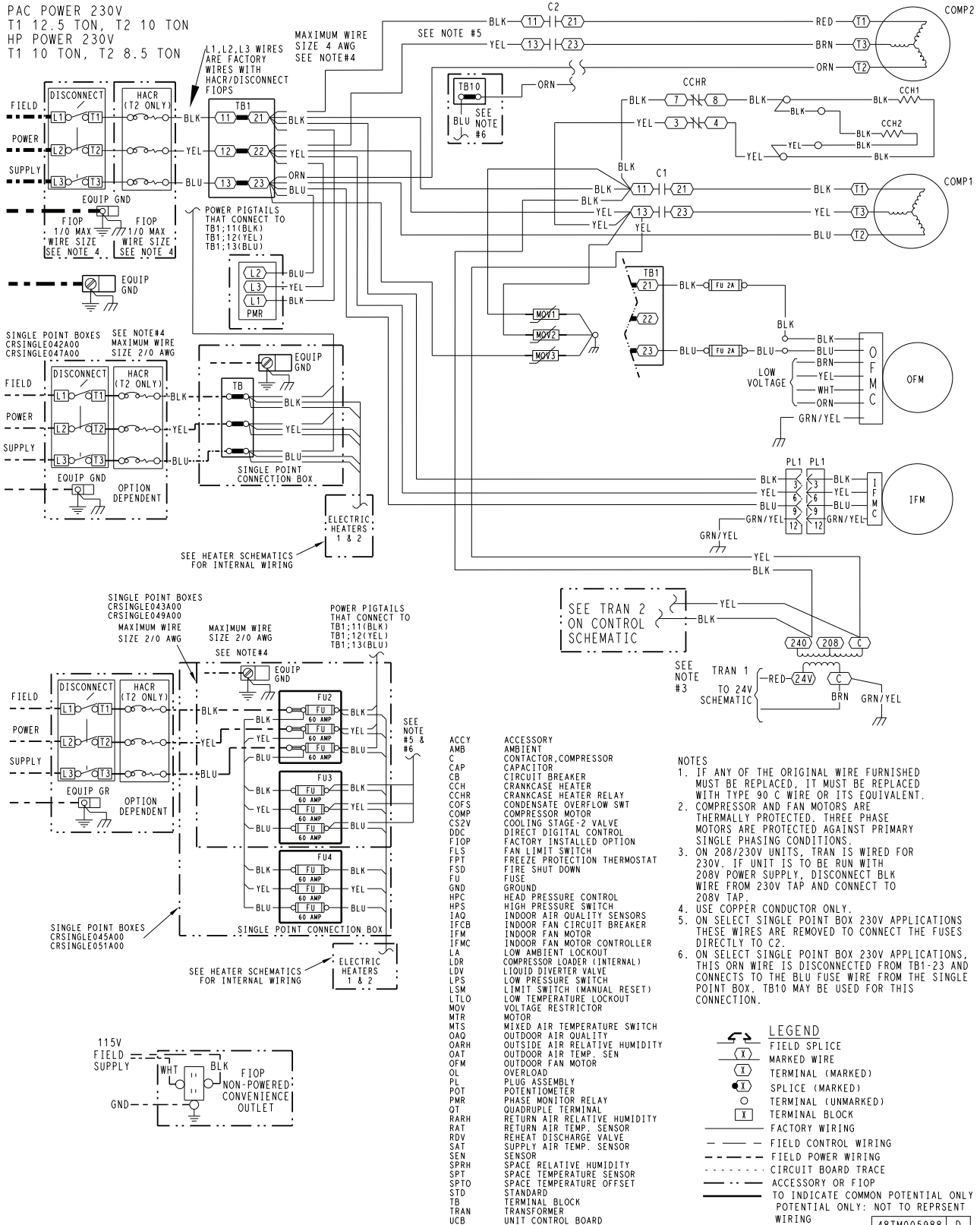



### Typical Control Wiring Diagram — 50FC 16 230/460/575-3-60 Unit with Electro-Mechanical Controller

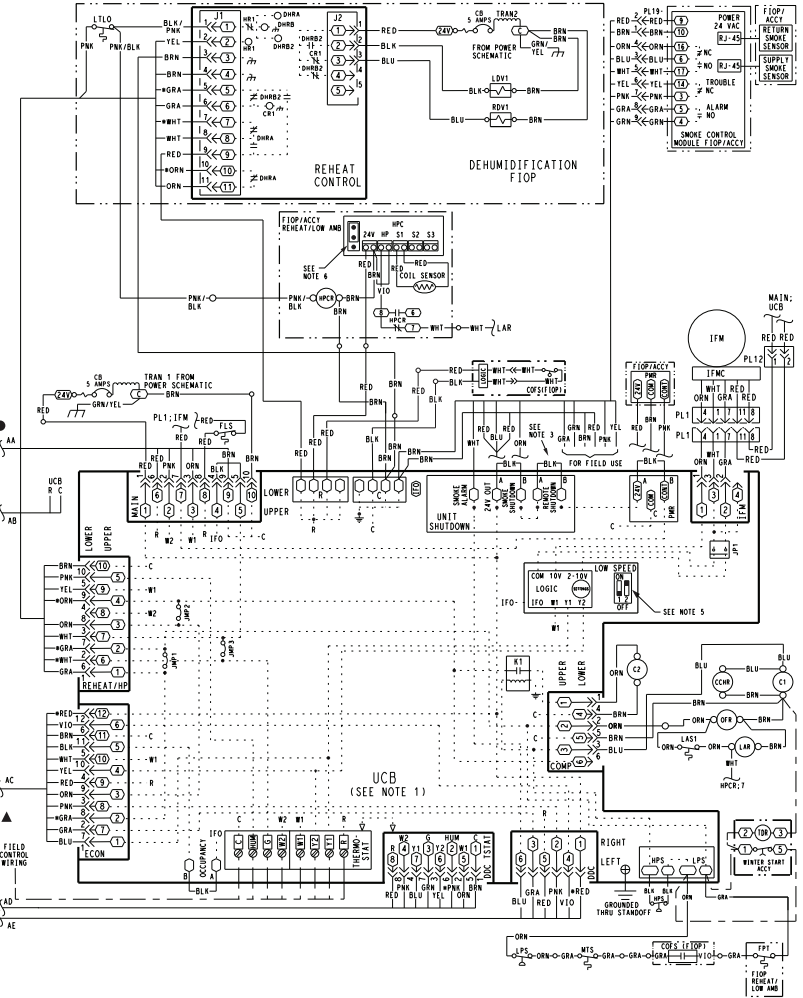
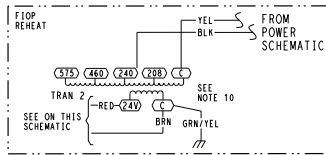
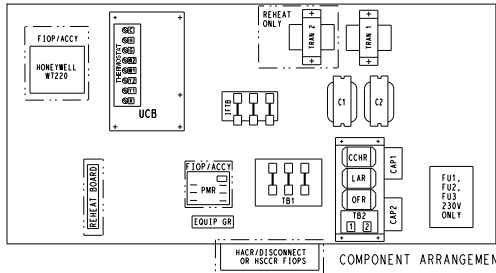

**NOTES:**

1. UCB LAYOUT DOES NOT MATCH ACTUAL TERMINAL BOARD LAYOUT.
2. TERMINAL BOARD JUMPERS 1, 2 AND 3 ARE CUT FOR REHEAT UNITS ONLY.
3. REMOVE DESIGNATED JUMPERS ON TERMINAL BOARD WHEN ADDING SMOKE DETECTORS, OCCUPANCY AND REMOTE SHUTDOWN.
4. USE ABC AS COARSE AND AS POT FINE ADJUSTMENTS FOR SETTING HIGH FAN SPEED. LOW SPEED IS AN OFFSET SET BASED ON DIP SWITCHES. 
5. 2-PIN LOW SPEED DIP SWITCH POSITIONS ARE FACTORY SET AS SHOWN.
6. HARDSTART AND CUTOFF SET TO "MIN". JUMPER PIN ON TOP 2-PINS AS SHOWN.
7. THE \* WIRE COLOR IS FOR DIFFERENTIATION WITHIN THIS SCHEMATIC.
8. TB4 LOCATED IN HEAT SECTION.
9. TO CONVERT TO A SINGLE STAGE HEATER MOVE VIOLET WIRE AT TB4 TO CONNECT WITH WHITE WIRE.
10. TRANSFORMER IS DEDICATED BASED ON UNIT VOLTAGE. TAPS ONLY SHOWN TO SIMPLIFY SCHEMATIC. 208/230V UNIT TRAN IS WIRED FOR 230V UNIT. IF UNIT IS TO BE RUN WITH 208V POWER SUPPLY DISCONNECT BLK WIRE FROM 230V TAP AND CONNECT TO 208V TAP.

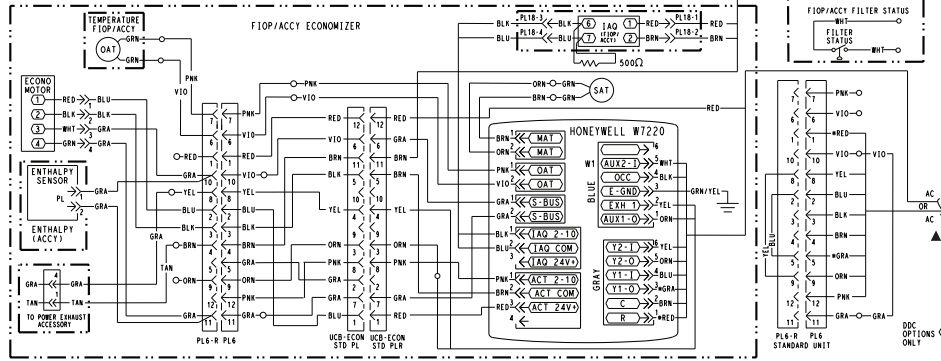

# Typical Control Wiring Diagram — 50FC 16 230/460/575-3-60 Unit with systemvu™ Controller

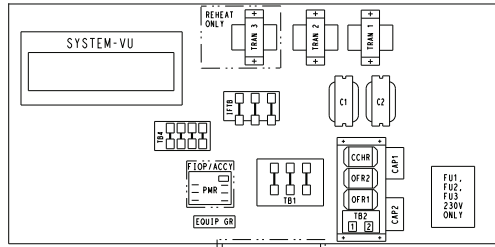

- NOTES:
1. LOW VOLTAGE CONNECTIONS MUST BE CLASS 2.
  2. USB-B AT J4 AND ETHERNETS AT J13, J14 ARE SHOWN FOR FUTURE USE.
  3. THE "Y3" TERMINAL IS CONFIGURABLE IN THE SOFTWARE.
  4. HARDCUT AND CUTOFF SET TO "MIN". JUMPER PIN ON TOP 2-PINS AS SHOWN.
  5. WHEN USING A RAIN SENSOR, MAKE CONNECTION IN THE RETURN AIR SECTION WHEN USING SPRH SENSOR, MAKE CONNECTION HERE BY DISCONNECTING YELLOW WIRE.
  6. T84 LOCATED IN HEAT SECTION.
  7. TO CONVERT TO A SINGLE STAGE HEATER MOVE VIOLET WIRE AT T84 TO CONNECT WITH WHITE WIRE.
  8. DISCONNECT VIO TO ALLOW POWER EXHAUST CONNECTION.
  9. CONNECT ELECTRIC HEATER CONTROL WIRING TO ORN ON T84 FOR FIRST STAGE HEATING(W1) AND TO VIO ON T84 FOR SECOND STAGE HEATING(W2).
  10. SEE HEATER INSTALLATION INSTRUCTIONS FOR MORE DETAILS.
  11. TRANSFORMER IS DEDICATED BASED ON UNIT VOLTAGE. TAPS ONLY SHOWN TO SIMPLIFY SCHEMATIC. 208/230V UNIT TRAN IS WIRED FOR 230V UNIT. IF UNIT IS TO BE RUN WITH 208V POWER SUPPLY DISCONNECT BLK WIRE FROM 230V TAP AND CONNECT TO 208V TAP.

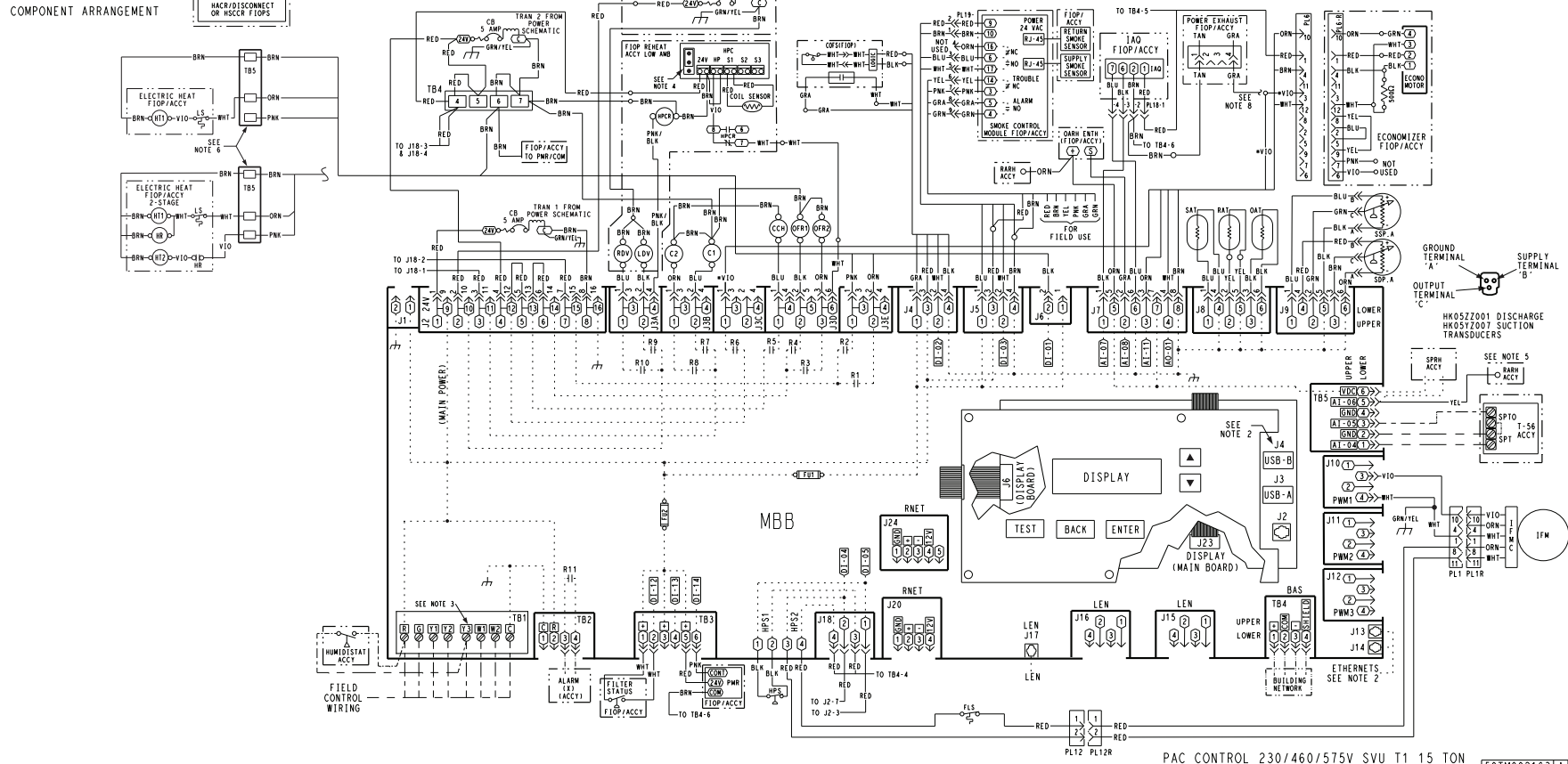
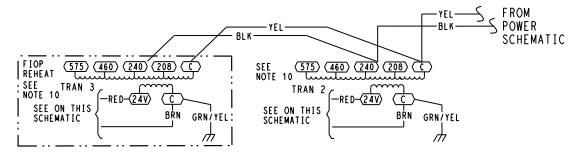

Typical wiring diagrams (cont)



50TM0021631A

## Typical Power Wiring Diagram — 50FC 16 208-230/460-3-60 Unit with Electro-Mechanical or SystemVu™ Controllers

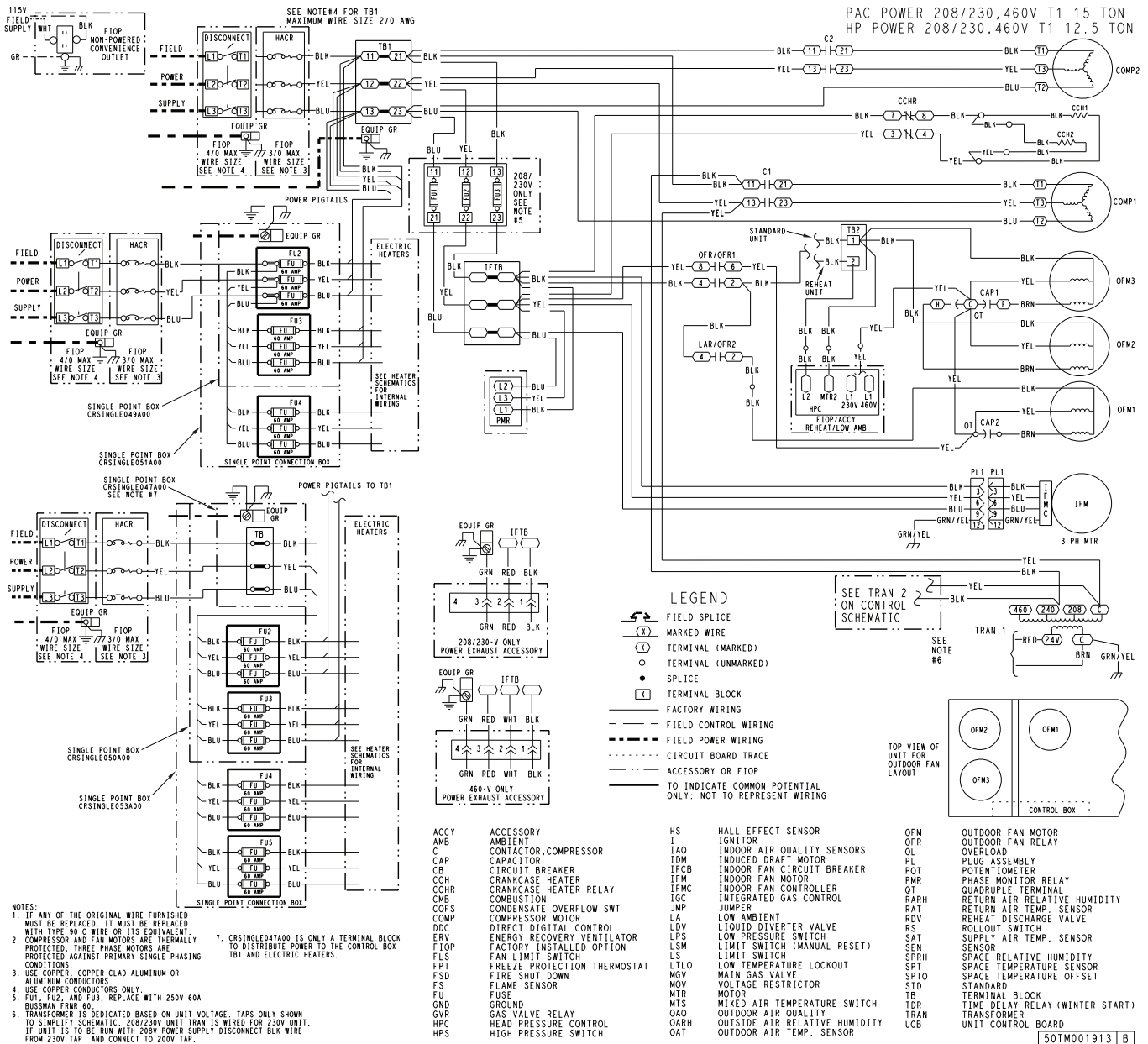

## Typical Power Wiring Diagram — 50FC 16 575-3-60 Unit with Electro-Mechanical or SystemVu™ Controllers

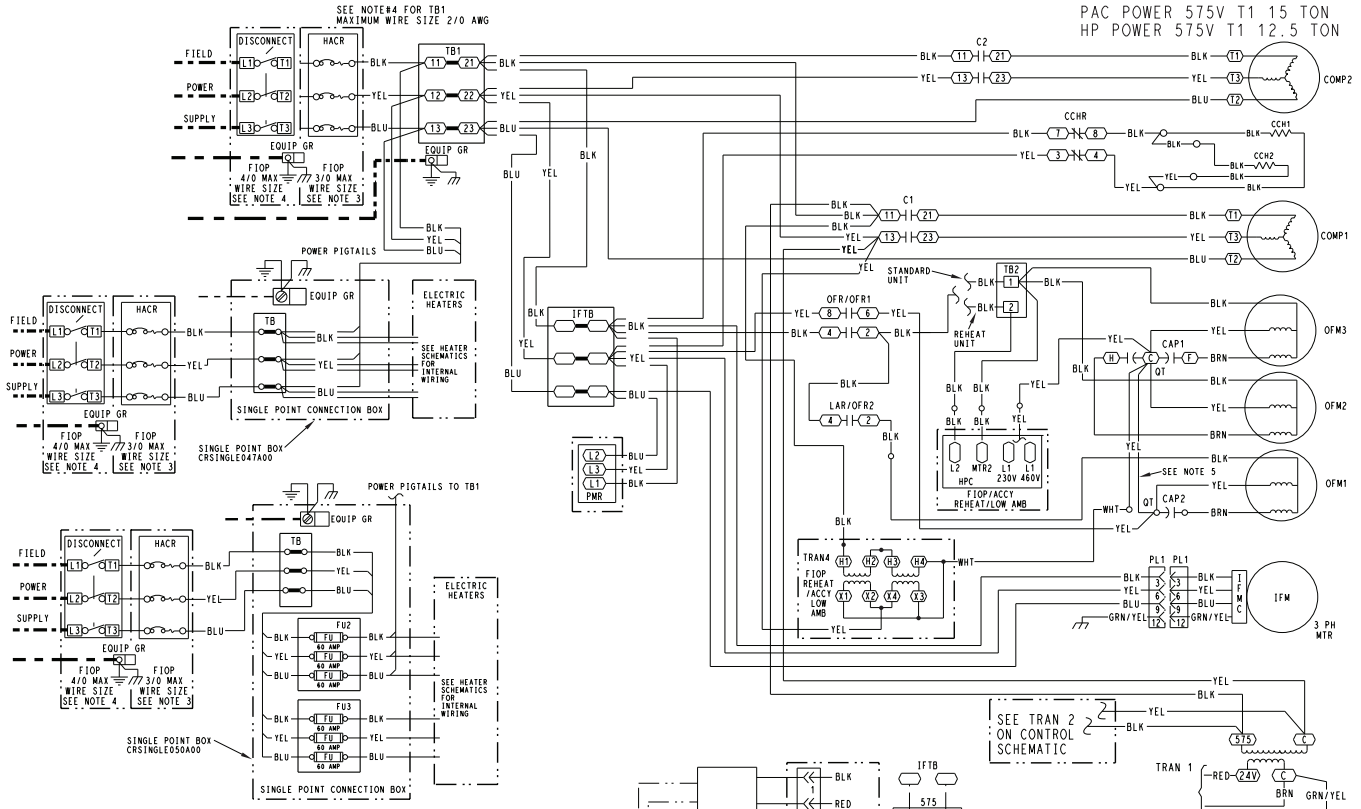

### LEGEND

- FIELD SPLICE
- MARKED WIRE
- TERMINAL (MARKED)
- TERMINAL (UNMARKED)
- SPLICE
- TERMINAL BLOCK
- FACTORY WIRING
- FIELD CONTROL WIRING
- FIELD POWER WIRING
- CIRCUIT BOARD TRACE
- ACCESSORY OR FIOP
- TO INDICATE COMMON POTENTIAL ONLY; NOT TO REPRESENT WIRING

### NOTES:

1. IF ANY OF THE ORIGINAL WIRE FURNISHED MUST BE REPLACED, IT MUST BE REPLACED WITH TYPE 90 C WIRE OR ITS EQUIVALENT.
2. COMPRESSOR AND FAN MOTORS ARE THERMALLY PROTECTED. THREE PHASE MOTORS ARE PROTECTED AGAINST PRIMARY SINGLE PHASING CONDITIONS.
3. USE COPPER, COPPER CLAD ALUMINUM OR ALUMINUM CONDUCTORS.
4. USE COPPER CONDUCTORS ONLY.
5. THIS WIRE IS REMOVED ON REHEAT/LOW AMBIENT UNITS TO ISOLATE CAPACITORS.

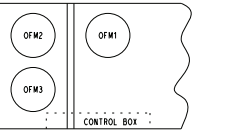
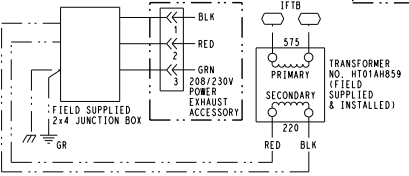
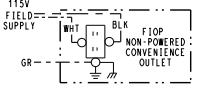

ACCY AMB C CAP CB CCH CCHR CMB COFS COMP DDC ERV FIOP FIS FPT FSD FS FU GND GVR HPC HPS	ACCESSORY AMBIENT CONTACTOR, COMPRESSOR CAPACITOR CIRCUIT BREAKER CRANKCASE HEATER CRANKCASE HEATER RELAY COMBUSTION CONDENSATE OVERFLOW SWT COMPRESSOR MOTOR DIRECT DIGITAL CONTROL ENERGY RECOVERY VENTILATOR FACTORY INSTALLED OPTION FAN LIMIT SWITCH FREEZE PROTECTION THERMOSTAT FIRE SHUT DOWN FLAME SENSOR FUSE GROUND GAS VALVE RELAY HEAD PRESSURE CONTROL HIGH PRESSURE SWITCH	HS IAQ IDM IFCB IFM IFMC IGC JMP L.A. LDV LPS LSM LS LTLO MGV MOV MTR MTS OAO OARH OAT	HALL EFFECT SENSOR IGNITOR INDOOR AIR QUALITY SENSORS INDUCED DRAFT MOTOR INDOOR FAN CIRCUIT BREAKER INDOOR FAN MOTOR INDOOR FAN CONTROLLER INTEGRATED GAS CONTROL JUMPER LOW AMBIENT LIQUID DIVERTER VALVE LOW PRESSURE SWITCH LIMIT SWITCH (MANUAL RESET) LIMIT SWITCH LOW TEMPERATURE LOCKOUT MAIN GAS VALVE VOLTAGE RESTRICTOR MOTOR MIXED AIR TEMPERATURE SWITCH OUTDOOR AIR QUALITY OUTSIDE AIR RELATIVE HUMIDITY OUTDOOR AIR TEMP. SENSOR	OFM OFR OL PL POT PMR QT RARH RAT RDV RS SAT SEN SPRH SPT STD TB TDR TRAN UCB	OUTDOOR FAN MOTOR OUTDOOR FAN RELAY OVERLOAD PLUG ASSEMBLY POTENTIOMETER PHASE MONITOR RELAY QUADRUPLE TERMINAL RETURN AIR RELATIVE HUMIDITY RETURN AIR TEMP. SENSOR REHEAT DISCHARGE VALVE ROLLOUT SWITCH SUPPLY AIR TEMP. SENSOR SENSOR SPACE RELATIVE HUMIDITY SPACE TEMPERATURE SENSOR SPACE TEMPERATURE OFFSET STANDARD TERMINAL BLOCK TIME DELAY RELAY (WINTER START) TRANSFORMER UNIT CONTROL BOARD
--	--	--	---	--	--

50TM001915 B

## General

The sequence below describes the sequence of operation for an electro-mechanical unit with and without a factory-installed EconoMi\$er® X (W7220 controller). For information regarding a direct digital controller, see the start-up, operations, and troubleshooting manual for the applicable controller.

## Electro-Mechanical Units with No EconoMizer

### Cooling (two stage units)

When the thermostat calls for cooling, terminals G and Y1 are energized. The indoor fan will run at the low fan speed and the C1 compressor contactor (CC) is energized causing the compressor and outdoor fan to run. The low indoor fan speed is 50% or 60% of the user set fan speed depending on unit size.

If additional cooling is needed, the thermostat will add the call for Y2. This will increase the indoor fan speed to the user set fan speed and energize the C2 contactor and second compressor for full compressor capacity. The outdoor fan is the same speed for Y1 and Y2.

When the thermostat removes the call for Y2 but leaves the Y1, the indoor fan will slow to the reduced percentage of the user set fan speed, the C2 contactor will de-energize, the second compressor will turn off, and the outdoor fan will remain on. When the thermostat removes the call for Y1 the compressor contactor will de-energize shutting down the compressor and the outdoor fan. When the thermostat removes the call for G, the indoor fan will turn off after the specific unit fan off delay.

NOTE: Per ASHRAE 90.1-2019 and IECC-2018 standards, during the first stage cooling operation the Unit Control Board (UCB) will adjust the fan motor speed to provide 50% or 60% of the total cfm established for the unit.

### Gas Heating (48FC units)

NOTE: WeatherMaker® units have 2 stages of gas heat.

When the thermostat calls for heating, power is sent to W on the Integrated Gas Controller (IGC) board. An LED (light-emitting diode) on the IGC board turns on and remains on during normal operation. A check is made to ensure that the roll-out switch and limit switch are closed. If the check was successful, the induced-draft motor is energized, and when its speed is satisfactory, as proven by the flue gas pressure switch, the ignition activation period begins. The burners will ignite within 5 seconds. If the burners do not light, there is a 22 second delay before another 5 second attempt. This sequence is repeated for 15 minutes or until the burners light. If, after the 15 minutes, the burners still have not lit, heating is locked out. To reset the control, break 24 V power to the thermostat.

When ignition occurs, the IGC board will continue to monitor the condition of the roll-out switch, the limit switches, the flue gas pressure switch, as well as the flame sensor. 45 seconds after ignition occurs, assuming the unit is controlled through a room thermostat set for fan auto, the indoor-fan motor will energize (and the outdoor-air dampers will open to their minimum position). If, for some reason, the over-temperature limit opens prior to the start of the indoor fan blower, the unit will shorten the 45 second delay to 5 seconds less than the time from initiation of heat to when the limit tripped. Gas will not be interrupted to the burners and heating will continue. Once the fan-on delay

has been modified, it will not change back to 45 seconds until power is reset to the control. On units with 2 stages of heat, when additional heat is required, W2 closes and initiates power to the second stage of the main gas valve. When the thermostat is satisfied, W1 and W2 open and the gas valve closes, interrupting the flow of gas to the main burners. If the unit is controlled through a room thermostat set for fan auto, the indoor-fan motor will continue to operate for an additional 45 seconds then stop. A LED indicator is provided on the IGC to monitor operation.

### Electric Heating (50FC units)

NOTE: 50FC units are sold as cooling only. If electric heaters are required, use only factory-approved heaters. They will operate as follows.

Units have either 1 or 2 stages of electric heat. When the thermostat calls for heating, power is applied to G and the W1 terminals at the unit. The unit control will energize the indoor fan contactor and the first stage of electric heat. On units with two-stage heating, when additional heating is required, the second stage of electric heat (if equipped) will be energized when power is applied at the W2 terminal on the unit.

**IMPORTANT:** The thermostat must be configured for Electric Heat so it will energize G with the W1 call.

## Electro-mechanical Units with Factory-Installed EconoMi\$er X

When free cooling is not available, the compressors will be controlled by the zone thermostat. When free cooling is available, the outdoor-air damper is modulated by the EconoMi\$er X control to provide a 50°F (10°C) to 55°F (13°C) mixed-air temperature into the zone. As the mixed air temperature fluctuates above 55°F (13°C) or below 50°F (10°C) dampers will be modulated (open or close) to bring the mixed-air temperature back within control. If mechanical cooling is utilized with free cooling, the outdoor-air damper will maintain its current position at the time the compressor is started. If the increase in cooling capacity causes the mixed-air temperature to drop below 45°F (7°C), then the outdoor-air damper position will be decreased to the minimum position. If the mixed-air temperature continues to fall, the outdoor-air damper will close. Control returns to normal once the mixed-air temperature rises above 48°F (9°C). The power exhaust fans will be energized and de-energized, if installed, as the outdoor-air damper opens and closes.

If field-installed accessory CO<sub>2</sub> sensors are connected to the EconoMi\$er X control, a demand controlled ventilation strategy will begin to operate. As the CO<sub>2</sub> level in the zone increases above the CO<sub>2</sub> set-point, the minimum position of the damper will be increased proportionally. As the CO<sub>2</sub> level decreases because of the increase in fresh air, the outdoor-air damper will be proportionally closed. For EconoMi\$er® X operation, there must be a thermostat call for the fan (G). If the unit is occupied and the fan is on, the damper will operate at minimum position. Otherwise, the damper will be closed.

When the EconoMi\$er IX control is in the occupied mode and a call for cooling exists (Y1 on the thermostat), the control will first check for indoor fan operation. If the fan is not on, then cooling will not be activated. If the fan is on, then the control will open the EconoMi\$er X damper to the minimum position.

On the initial power to the EconoMi\$er X control, it will take the damper up to 2 1/2 minutes before it begins to

# Sequence of operation (cont)



position itself. After the initial power-up, further changes in damper position can take up to 30 seconds to initiate. Damper movement from full closed to full open (or vice versa) will take between 1 1/2 and 2 1/2 minutes. If free cooling can be used as determined from the appropriate changeover command (switch, dry bulb, enthalpy curve, differential dry bulb, or differential enthalpy), then the control will modulate the dampers open to maintain the mixed-air temperature set-point at 50°F (10°C) to 55°F (13°C). If there is a further demand for cooling (cooling second stage — Y2 is energized), then the control will bring on compressor stage 1 to maintain the mixed-air temperature set-point. The EconoMi\$er X damper will be open at maximum position.

**2-Speed Note:** The EconoMi\$er X controller will adjust the damper position as the Indoor Fan Speed changes, per its configured values.

## Heating

The sequence of operation for the heating is the same as an electro-mechanical unit with no economizer. The only difference is how the economizer acts. The economizer will stay at the Economizer Minimum Position while the evaporator fan is operating. The outdoor-air damper is closed when the indoor fan is not operating. Refer to Service and Maintenance Manual for further details.

## Optional Humidi-MiZer® dehumidification system

Units with the factory equipped Humidi-MiZer system option are capable of providing multiple modes of improved dehumidification as a variation of the normal cooling cycle. The Humidi-MiZer system option includes additional valves in the liquid line and discharge line of each refrigerant circuit, a small reheat condenser coil downstream of the evaporator, and variable-speed control of some or all outdoor fans. Operation of the revised refrigerant circuit for each mode is described below.

The Humidi-MiZer system provides three sub-modes of operation: Cool, Reheat1, and Reheat2.

**Cool mode** — Provides a normal ratio of Sensible and Latent Cooling effect from the evaporator coil.

**Reheat1** — Provides increased Latent Cooling while slightly reducing the Sensible Cooling effect.

**Reheat2** — Provides normal Latent Cooling but with null or minimum Sensible Cooling effect delivered to the space.

The Reheat1 and Reheat2 modes are available when the unit is not in a Heating mode and when the Low Ambient Lockout switch is closed.

Refer to the following figures for piping flow diagrams.

## SystemVu™ controller (factory option)

For details on operating 48/50FC units equipped with the factory-installed SystemVu controller option, refer to FC/GC Series Single Package Rooftop Units with SystemVu Controller Controls, Start-Up, Operation and Troubleshooting manual.

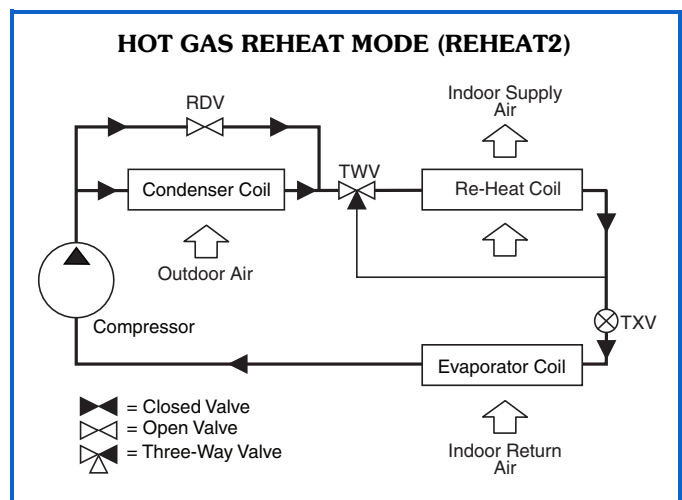
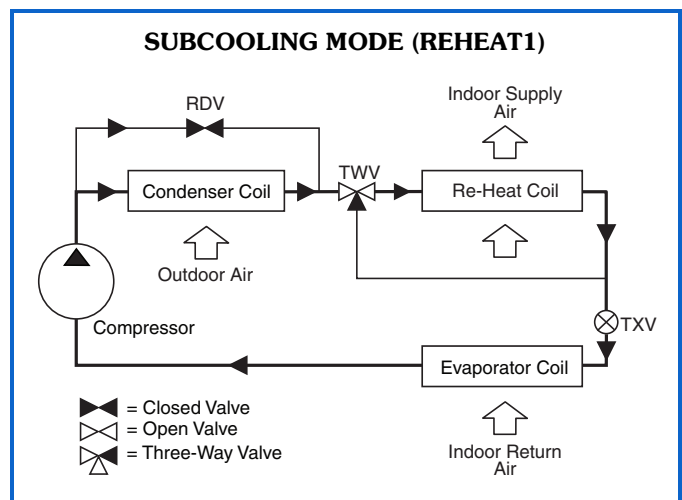
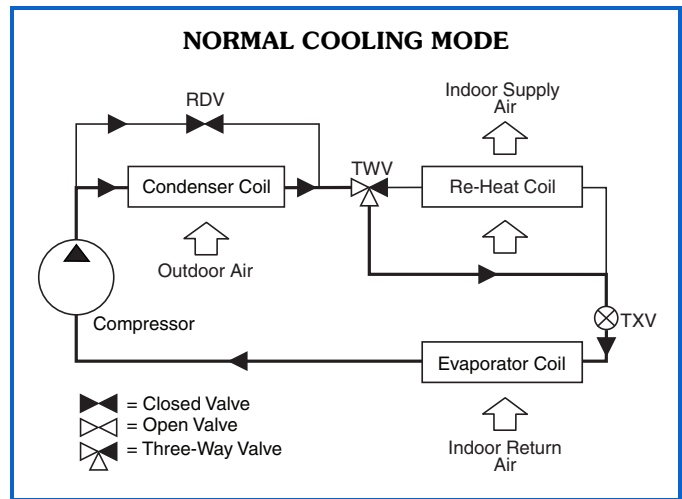

- LEGEND**
- RDV** — Reheat Discharge Valve
  - TWV** — Three-Way Valve
  - TXV** — Thermostatic Expansion Valve

## Minimum operating ambient temperature (cooling)

In mechanical cooling mode, your Carrier rooftop unit can safely operate down to an outdoor ambient temperature of 40°F (4°C) [0°F (-18°C) for size 14 models]. It is possible to provide cooling at lower outdoor ambient temperatures by using less outside air, economizers, and/or accessory low ambient kits.

## Maximum operating ambient temperature (cooling)

The maximum operating ambient temperature for cooling mode is 125°F (52°C) except for size 14 models with 120°F (49°C). While cooling operation above 115°F (46°C) [120°F (49°C) for size 14 models] may be possible, it could cause either a reduction in performance, reliability, or a protective action by the unit's internal safety devices.

## Multiple motor and drive packages

Some applications need larger horsepower motors, some need more airflow, and some need both. Regardless of the case, your Carrier expert has a factory installed combination to meet your application. A wide selection of motors are available, factory installed, to handle nearly any application.

## Stainless steel heat exchanger (48FC units only)

The stainless steel heat exchanger option provides the tubular heat exchanger be made out of a minimum 20 gage type 409 stainless steel for applications where the mixed air to the heat exchanger is expected to drop below 45°F (7°C). Stainless steel may be specified on applications where the presence of airborne contaminants require its use (applications such as paper mills) or in area with very high outdoor humidity that may result in severe condensation in the heat exchanger during cooling operation.

## Minimum mixed air temperature (heating) (48FC units only)

Using the factory settings, the minimum temperatures for the mixed air (the combined temperature of the warm return air and the cold outdoor air) entering the dimpled, gas heat exchangers are shown in the following table.

**Minimum Temperature for Mixed Air Temperature**

ALUMINIZED	STAINLESS STEEL
50°F (10°C) Continuous	40°F (4°C) Continuous
45°F (7°C) Intermittent	35°F (2°C) Intermittent

Operating at lower mixed-air temperatures may be possible, if a field-supplied, outdoor air thermostat initiates both heat stages when the temperature is less than the minimum temperatures listed above. Please contact your local Carrier representative for assistance.

## Minimum and maximum airflow (heating and cooling)

To maintain safe and reliable operation of your rooftop, operate within the heating airflow limits during heating mode and cooling airflow limits during cooling mode. Operating above the max may cause blow-off, undesired airflow noise, or airflow related problems with the rooftop unit. Operating below the min may cause problems with coil freeze-up and unsafe heating operation. Heating and cooling limitations differ when evaluating operating CFM,

minimum value is the HIGHER of the cooling and heating minimum CFM values published on page 8 and the maximum value is the LOWER of the cooling and heating maximum values published on page 8.

## Heating-to-cooling changeover

Your unit will automatically change from heating to cooling mode when using a thermostat with an auto-changeover feature.

## Airflow

All units are draw-through in cooling mode and blow-through in heating mode.

## Outdoor air application strategies

Economizers reduce operating expenses and compressor run time by providing a free source of cooling and a means of ventilation to match application changing needs. In fact, they should be considered for most applications. Also, consider the various economizer control methods and their benefits, as well as sensors required to accomplish your application goals. Please contact your local Carrier representative for assistance.

## Motor limits, break horsepower (bhp)

Due to internal design of Carrier units, the air path, and specially designed motors, the full horsepower (maximum continuous bhp) band, as listed in the Fan Performance tables, can be used with the utmost confidence. There is no need for extra safety factors, as Carrier motors are designed and rigorously tested to use the entire, listed bhp range without either nuisance tripping or premature motor failure.

## Propane heating (48FC units only)

Propane has different physical qualities than natural gas. As a result, propane requires different fuel to air mixture. To optimize the fuel/air mixture for propane, Carrier sells different burner orifices in an easy to install accessory kit. To select the correct burner orifices or determine the heat capacity for a propane application, use either the selection software, or the unit's service manual.

## High altitude heating

High altitudes have less oxygen, which affects the fuel/air mixture in heat exchangers. In order to maintain a proper fuel/air mixture, heat exchangers operating in altitudes above 2000 ft (610 m) require different orifices. To select the correct burner orifices or determine the heat capacity for a high altitude application, use either the selection software, or the unit's service manual.

High altitudes have less oxygen, which means heat exchangers need less fuel. The new gas orifices in this field-installed kit make the necessary adjustment for high altitude applications. They restore the optimal fuel to air mixture and maintain healthy combustion on altitudes above 2000 ft (610 m).

NOTE: Typical natural gas heating value ranges from 975 to 1050 Btu/ft<sup>3</sup> at sea level nationally. The heating value goes down approximately 1.7% per every thousand feet elevation. Standard factory orifices can typically be used up to 2000 ft (610 m) elevation without any operational issues.

## **Sizing a rooftop**

Bigger is not necessarily better. While an air conditioner needs to have enough capacity to meet the design loads, it does not need excess capacity. In fact, excess capacity typically results in very poor part load performance and humidity control.

Using higher design temperatures than ASHRAE recommends for your location, adding “safety factors” to the calculated load, are all signs of oversizing air conditioners. Oversizing the air conditioner leads to poor humidity control, reduced efficiency, higher utility bills, larger indoor temperature swings, excessive noise, and increased wear and tear on the air conditioner.

Rather than oversizing an air conditioner, engineers should “right-size” or even slightly “under-size” air conditioners. Correctly sizing an air conditioner controls humidity better; promotes efficiency; reduces utility bills; extends equipment

life, and maintains even, comfortable temperatures. Please contact your local Carrier representative for assistance.

## **Low ambient applications**

The optional Carrier economizer can adequately cool your space by bringing in fresh, cool outside air. In fact, when so equipped, accessory low-ambient kit may not be necessary. In low ambient conditions, unless the outdoor air is excessively humid or contaminated, economizer-based “free cooling” is the preferred less costly and energy conscious method. In low ambient applications where outside air might not be desired (such as contaminated or excessively humid outdoor environments), your Carrier rooftop can operate to ambient temperatures down to  $-0^{\circ}\text{F}$  ( $-18^{\circ}\text{C}$ ) using the recommended accessory low ambient controller.

NOTE:  $0^{\circ}\text{F}$  ( $-18^{\circ}\text{C}$ ) is standard on size 14 models.



Note about this specification:

This specification is in the “Masterformat” as published by the Construction Specification Institute. Please feel free to copy this specification directly into your building spec.



## Gas Heat/Electric Cooling Packaged Rooftop

### HVAC Guide Specifications

Size Range: **7.5 to 15 Nominal Tons**

Carrier Model Number: **48FC\*08-16**

#### Part 1 — (23 06 80) Schedules for Decentralized HVAC Equipment

1.01 (23 06 80.13) Decentralized Unitary HVAC Equipment Schedule

A. (23 06 80.13.A.) Rooftop unit (RTU) schedule:

1. Schedule is per the project specification requirements.

#### Part 2 — (23 07 16) HVAC equipment insulation

2.01 (23 07 16.13) Decentralized, Rooftop Units:

A. (23 07 16.13.A.) Evaporator fan compartment:

1. Interior cabinet surfaces shall be insulated with a minimum 1/2 in. thick, minimum 1 1/2 lb density, flexible fiberglass insulation bonded with a phenolic binder, neoprene coated on the air side.
2. Insulation and adhesive shall meet NFPA 90A requirements for flame spread and smoke generation.

B. (23 07 16.13.B.) Gas Heat Compartment:

1. Aluminum foil-faced fiberglass insulation shall be used.
2. Insulation and adhesive shall meet NFPA 90A requirements for flame spread and smoke generation.

#### Part 3 — (23 09 13) Instrumentation and control devices for HVAC

3.01 (23 09 13.23) Sensors and Transmitters

A. (23 09 13.23.A.) Thermostats

1. Thermostat must
  - a. energize both “W” and “G” when calling for heat.
  - b. have capability to energize 1 or 2 stages of cooling, and 2 different stages of heating.
  - c. include capability for occupancy scheduling.

#### Part 4 — (23 09 23) Direct Digital Control system for HVAC

4.01 (23 09 23.13) Decentralized, Rooftop Units:

A. (23 09 23.13.A.) SystemVu™ intelligent integrated Direct Digital Control (DDC) shall provide:

1. Integrated unit operation for comfort cooling, heating ventilation as well as all monitoring,

recording and reporting capabilities. Controller shall also provide diagnostics and alarms of abnormal unit operation through the controller. Controller shall have an intuitive user display and be able to be used in a standalone operation or via building automation system (BAS).

2. Quick Unit Status LEDs of: RUN – meaning all systems are go, ALERT – that indicates there is currently a non-critical issue with the unit, like filters need to be replaced and FAULT – that indicates the unit has a critical issue and will possibly shut down.
3. Six large navigation keys for easy access. Navigation keys shall consist of: TEST, BACK, ENTER, and MENU along with UP and DOWN arrows.
4. Full back lit user display with 4 line by 30 character text capabilities. Display menu shall be designed to provide guided major menus and sub menus main menus provided below:
  - a. Shutdown Unit
  - b. Run Status
  - c. Settings
  - d. Alerts/Faults
  - e. Service
  - f. Inputs
  - g. Outputs
  - h. USB
5. The capability for standalone operation with conventional thermostat/sensor or use with building automation systems (BAS) of Carrier i-Vu®, BACnet MS/PT and Carrier Comfort Network® (CCN) systems. No special modules or boards are required for these capabilities. Has the capability to work with Equipment Touch™ and System Touch™ devices and ZS Sensors.
6. The ability to read refrigerant pressures at display or via BAS network of Discharge Pressure and Suction Pressure. The need for traditional refrigerant gages is not required.
7. USB Data Port for flash drive interaction. This will allow the transfer of data for uploads, downloads, perform software upgrades, backup and restore data and file transfer data such as component number of starts and run hours.
8. Reverse Rotation Protection of compressors if field three phase wiring is misapplied.
9. Provide Service Capabilities of:
  - a. Auto run test
  - b. Manual run test
  - c. Component run hours and starts
  - d. Commissioning reports
  - e. Data logging
  - f. Alarm history

10. Economizer control and diagnostics. Set up economizer operation, receive feedback from actuator. Also meets the most recent California Title 24, ASHRAE 90.1 and IECC Fault Detection and Diagnostic (FDD) requirements.
11. Unit cooling operation down to 40°F (4°C) [0°F (-18°C) for size 14 models].
12. Controller shall have easy access connections around the controller perimeter area and consist of Mate-N-Lok, terminal block and RJ style modular jack connections.
13. 365 day real time clock, 20 holiday schedules along with occupied and unoccupied scheduling.
14. Auto-Recognition for easy installation and commissioning of devices like economizers, space sensors etc.
15. A 5°F temperature difference between cooling and heating set points to meet the latest ASHRAE 90.1 Energy Standard.
16. Contain return air sensor, supply air sensor and outdoor air sensor to help monitor and provide data for the unit comfort operation, diagnostic and alarms.
17. Use of Carrier's field accessory hand-held Navigator™ display, Equipment Touch and System Touch devices.
18. Units with the factory-installed Humidi-MiZer® system option are capable of providing multiple modes of improved dehumidification as a variation of the normal cooling cycle.
19. Supply Air Tempering control operates the gas or electric heat to maintain a minimum supply air temperature during conditions where very cold outdoor air causes the supply air temperature to fall below the configured Supply Air Tempering Setpoint. This occurs during periods where DCV is active and increasing the amount of outdoor air or in cases where the system is operating at very low airflow and the calculated economizer position has increased to maintain a constant ventilation rate.
20. Demand limiting in SystemVu™ is achieved through set point expansion. The systems heating and cooling set points are expanded in steps or levels. The degree to which the set points may be expanded is defined by the 6 demand level offsets and the 2 commanded demand limit levels.
21. 3-year limited part warranty.

## **Part 5 — (23 09 33) Electric and Electronic Control System for HVAC**

### 5.01 (23 09 33.13) Decentralized, Rooftop Units:

#### A. (23 09 33.13.A.) General:

1. Shall be complete with self-contained low-voltage control circuit protected by a resettable circuit

breaker on the 24-v transformer side. Transformer shall have 75VA capability.

2. Shall utilize color-coded wiring.
3. Shall include a Unit Control Board to conveniently and safely provide connection points for vital control functions such as: smoke detectors, phase monitor, gas controller, economizer, thermostat, DDC control options, and low and high pressure switches. Controller shall also provide an intuitive means to adjust the indoor fan speed through a simple switch and pot adjustment design.
4. The heat exchanger shall be controlled by an integrated gas controller (IGC) microprocessor. See heat exchanger section of this specification.
5. Unit shall include a minimum of one 8-pin screw terminal connection board for connection of control wiring.

#### B. (23 09 33.13.B.) Safeties:

1. Compressor over-temperature, over-current. High internal pressure differential.
2. Low pressure switch.
  - a. Low pressure switch shall use different color wire than the high pressure switch. The purpose is to assist the installer and service technician to correctly wire and or troubleshoot the rooftop unit.
3. High pressure switch.
  - a. High pressure switch shall use different color wire than the low pressure switch. The purpose is to assist the installer and service technician to correctly wire and or troubleshoot the rooftop unit.
4. Mixed air auto re-set temperature switch.
  - a. When return air temperatures get the critical point that can cause compressor reliability issues, this switch will shut down compression only until the temperature raise accordingly. Switch opens at 60°F (16°C) and closes at 65°F (18°C).
5. Automatic reset, motor thermal overload protector.
6. Heating section shall be provided with the following minimum protections:
  - a. High temperature limit switches.
  - b. Induced draft motor speed sensor.
  - c. Flame rollout switch.
  - d. Flame proving controls.

## **Part 6 — (23 09 93) Sequence of Operations for HVAC Controls**

### 6.01 (23 09 93.13) Decentralized, Rooftop Units:

- A. (23 09 93.13.A.) INSERT SEQUENCE OF OPERATION

## Part 7 — (23 40 13) Panel Air Filters

### 7.01 (23 40 13.13) Decentralized, Rooftop Units:

- A. (23 40 13.13.A.) Standard filter section:
1. Shall consist of factory installed, low velocity, disposable 2 in. thick fiberglass filters of commercially available sizes.
  2. Unit shall use only one filter size. Multiple sizes are not acceptable.
  3. Filters shall be accessible through an access panel with “no-tool” removal as described in the unit cabinet section of this specification (23 81 19.13.G).

## Part 8 — (23 81 19) Self-Contained Air Conditioners

### 8.01 (23 81 19.13) Small-Capacity Self-Contained Air Conditioners:

- A. (23 81 19.13.A.) General:
1. Outdoor, rooftop mounted, electrically controlled, heating and cooling unit utilizing a fully hermetic scroll compressors for cooling duty and gas combustion for heating duty.
  2. Factory assembled, single-piece heating and cooling rooftop unit. Contained within the unit enclosure shall be all factory wiring, piping, controls, and special features required prior to field start-up.
  3. Unit shall use Puron® (R-410A) refrigerant.
  4. Unit shall be installed in accordance with the manufacturer’s instructions.
  5. Unit must be selected and installed in compliance with local, state, and federal codes.
- B. (23 81 19.13.B.) Quality Assurance:
1. Unit meets ASHRAE 90.1 minimum efficiency requirements.
  2. Unit shall be rated in accordance with AHRI Standards 340/360.
  3. Unit shall be designed to conform to ASHRAE 15.
  4. Unit shall be UL-tested and certified in accordance with ANSI Z21.47 Standards and UL-listed and certified under Canadian standards as a total package for safety requirements.
  5. Insulation and adhesive shall meet NFPA 90A requirements for flame spread and smoke generation.
  6. Unit casing shall be capable of withstanding 500 hour salt spray exposure per ASTM B117 (scribed specimen).
  7. Unit shall be designed in accordance with ISO 9001, and shall be manufactured in a facility registered by ISO 9001:2015.
  8. Roof curb shall be designed to conform to NRCA Standards.
  9. Unit shall be subjected to a completely automated run test on the assembly line. The data for each unit will be stored at the factory, and must be available upon request.

10. Unit shall be designed in accordance with UL Standard 60335-2-40, including tested to withstand rain.

11. Unit shall be constructed to prevent intrusion of snow and tested to prevent snow intrusion into the control box up to 40 mph.

12. Unit shake tested to assurance level 1, ASTM D4169 to ensure shipping reliability.

C. (23 81 19.13.C.) Delivery, Storage, and Handling:

1. Unit shall be stored and handled per manufacturer’s recommendations.

2. Lifted by crane requires either shipping top panel or spreader bars.

3. Unit shall only be stored or positioned in the upright position.

D. (23 81 19.13.D.) Project Conditions:

1. As specified in the contract.

E. (23 81 19.13.E.) Operating Characteristics:

1. Unit shall be capable of starting and running at 125°F (52°C) ambient outdoor temperature except 14 size models that are capable of starting and running at 120°F (49°C), meeting maximum load criteria of AHRI Standard 210/240 or 340/360 at ±10% voltage.

2. Compressor with standard controls shall be capable of operation down to 40°F (4°C) [0°F (-18°C) for size 14 models], ambient outdoor temperatures. Accessory winter start kit is necessary if mechanically cooling at ambient temperatures down to 25°F (-4°C) or 0°F (-18°C).

3. Unit shall discharge supply air vertically or horizontally as shown on contract drawings.

4. Unit shall be factory configured for vertical supply and return configurations.

5. Unit shall be field convertible from vertical to horizontal airflow on all models. No special kit required except on 16 size models that require a Supply Duct Kit field installed for horizontal air flow.

6. Unit shall be capable of mixed operation: vertical supply with horizontal return or horizontal supply with vertical return.

F. (23 81 19.13.F.) Electrical Requirements:

1. Main power supply voltage, phase, and frequency must match those required by the manufacturer.

G. (23 81 19.13.G.) Unit Cabinet:

1. Unit cabinet shall be constructed of galvanized steel, and shall be bonderized and coated with a prepainted baked enamel finish on all externally exposed surfaces.

2. Unit cabinet exterior paint shall be: film thickness, (dry) 0.003 inches minimum, gloss (per ASTM D523, 60°F/16°C): 60, Hardness: H-2H Pencil hardness.

3. Evaporator fan compartment interior cabinet insulation shall conform to AHRI Standards 340/360 minimum exterior sweat criteria. Interior surfaces shall be insulated with a minimum 1/2 in. thick, 1 lb density, flexible fiberglass insulation, neoprene coated on the air side. Aluminum foil-faced fiberglass insulation shall be used in the gas heat compartment.
4. Base of unit shall have a minimum of four locations for thru-the-base gas and electrical connections (factory-installed or field-installed), standard.
5. Base Rail:
  - a. Unit shall have base rails on a minimum of 2 sides.
  - b. Holes shall be provided in the base rails for rigging shackles to facilitate maneuvering and overhead rigging.
  - c. Holes shall be provided in the base rail for moving the rooftop by fork truck.
  - d. Base rail shall be a minimum of 16 gage thickness.
6. Condensate pan and connections:
  - a. Shall be a sloped condensate drain pan made of a corrosion resistant material.
  - b. Shall comply with ASHRAE Standard 62.
  - c. Shall use a 3/4 in. 14 NPT drain connection, possible either through the bottom or side of the drain pan. Connection shall be made per manufacturer's recommendations.
7. Top panel:
  - a. Shall be a single piece top panel on 08-14 models and two piece on 16 size models.
8. Gas Connections:
  - a. All gas piping connecting to unit gas valve shall enter the unit cabinet at a single location on side of unit (horizontal plane).
  - b. Thru-the-base capability:
    - 1) Standard unit shall have a thru-the-base gas-line location using a raised, embossed portion of the unit basepan.
    - 2) Optional, factory approved, water-tight connection method must be used for thru-the-base gas connections.
    - 3) No basepan penetration, other than those authorized by the manufacturer, is permitted.
9. Electrical Connections:
  - a. All unit power wiring shall enter unit cabinet at a single, factory prepared, knockout location.
  - b. Thru-the-base capability:
    - 1) Standard unit shall have a thru-the-base electrical location(s) using a raised, embossed portion of the unit basepan.

- 2) Optional, factory approved, water-tight connection method must be used for thru-the-base electrical connections.
  - 3) No basepan penetration, other than those authorized by the manufacturer, is permitted.
10. Component access panels (standard):
    - a. Cabinet panels shall be easily removable for servicing.
    - b. Unit shall have one factory installed, tool-less, removable, filter access panel.
    - c. Panels covering control box, indoor fan, indoor fan motor, gas components (where applicable), and compressors shall have molded composite handles.
    - d. Handles shall be UV modified, composite. They shall be permanently attached, and recessed into the panel.
    - e. Screws on the vertical portion of all removable access panel shall engage into heat resistant, molded composite collars.
    - f. Collars shall be removable and easily replaceable using manufacturer recommended parts.
- H. (23 81 19.13.H.) Gas Heat:
1. General:
    - a. Heat exchanger shall be an induced draft design. Positive pressure heat exchanger designs shall not be allowed.
    - b. Shall incorporate a direct-spark ignition system and redundant main gas valve.
    - c. Gas supply pressure at the inlet to the rooftop unit gas valve must match that required by the manufacturer.
  2. The heat exchanger shall be controlled by an integrated gas controller (IGC) microprocessor.
    - a. IGC board shall notify users of fault using an LED (light-emitting diode).
    - b. The LED shall be visible without removing the control box access panel.
    - c. IGC board shall contain algorithms that modify evaporator fan operation to prevent future cycling on high temperature limit switch.
    - d. Unit shall be equipped with anti-cycle protection with one short cycle on unit flame rollout switch or 4 continuous short cycles on the high temperature limit switch. Fault indication shall be made using an LED.
  3. Standard Heat Exchanger construction:
    - a. Heat exchanger shall be of the tubular-section type constructed of a minimum of 20-gage steel coated with a nominal 1.2 mil aluminum-silicone alloy for corrosion resistance.
    - b. Burners shall be of the in-shot type constructed of aluminum-coated steel.

- c. Burners shall incorporate orifices for rated heat output up to 2000 ft (610 m) elevation. Additional accessory kits may be required for applications above 2000 ft (610 m) elevation, depending on local gas supply conditions.
  - d. Each heat exchanger tube shall contain multiple dimples for increased heating effectiveness.
4. Optional Stainless Steel Heat Exchanger construction:
    - a. Use energy saving, direct-spark ignition system.
    - b. Use a redundant main gas valve.
    - c. Burners shall be of the in-shot type constructed of aluminum-coated steel.
    - d. All gas piping shall enter the unit cabinet at a single location on side of unit (horizontal plane).
    - e. The optional stainless steel heat exchanger shall be of the tubular-section type, constructed of a minimum of 20-gage type 409 stainless steel.
    - f. Type 409 stainless steel shall be used in heat exchanger tubes and vestibule plate.
    - g. Complete stainless steel heat exchanger allows for greater application flexibility.
  5. Induced draft combustion motor and blower:
    - a. Shall be a direct-drive, single inlet, forward-curved centrifugal type.
    - b. Shall be made from steel with a corrosion resistant finish.
    - c. Shall have permanently lubricated sealed bearings.
    - d. Shall have inherent thermal overload protection.
    - e. Shall have an automatic reset feature.
- I. (23 81 19.13.I.) Coils:
    1. Standard Aluminum Fin-Copper Tube Coils:
      - a. Standard evaporator and condenser coils shall have aluminum lanced plate fins mechanically bonded to seamless internally grooved copper tubes with all joints brazed.
      - b. Evaporator coils shall be leak tested to 150 psig, pressure tested to 450 psig, and qualified to UL 1995 burst test at 1775 psig.
      - c. Condenser coils shall be leak tested to 150 psig, pressure tested to 650 psig, and qualified to UL 1995 burst test at 1980 psig.
    2. Optional Pre-coated aluminum-fin condenser coils:
      - a. Shall have a durable epoxy-phenolic coating to provide protection in mildly corrosive coastal environments.
    3. Optional Copper-fin evaporator and condenser coils:
      - a. Shall be constructed of copper fins mechanically bonded to copper tubes and copper tube sheets.
      - b. Galvanized steel tube sheets shall not be acceptable.
      - c. A polymer strip shall prevent coil assembly from contacting the sheet metal coil pan to minimize potential for galvanic corrosion between coil and pan.
    4. Optional E-coated aluminum-fin evaporator and condenser coils:
      - a. Shall have a flexible epoxy polymer coating uniformly applied to all coil surface areas without material bridging between fins.
      - b. Coating process shall ensure complete coil encapsulation of tubes, fins and headers.
      - c. Color shall be high gloss black with gloss per ASTM D523-89.
      - d. Uniform dry film thickness from 0.8 to 1.2 mil on all surface areas including fin edges.
      - e. Superior hardness characteristics of 2H per ASTM D3363-92A and cross-hatch adhesion of 4B-5B per ASTM D3359-93.
      - f. Impact resistance shall be up to 160 in. lb (ASTM D2794-93).
      - g. Humidity and water immersion resistance shall be up to minimum 1000 and 250 hours respectively (ASTM D2247-92 and ASTM D870-92).
- b. Coating shall be applied to the aluminum fin stock prior to the fin stamping process to create an inert barrier between the aluminum fin and copper tube.
  - c. Epoxy-phenolic barrier shall minimize galvanic action between dissimilar metals.
  - d. Corrosion durability of fin stock shall be confirmed through testing to be no less than 1000 hours salt spray per ASTM B117-90.
  - e. Corrosion durability of fin stock shall be confirmed through testing to have no visible corrosion after 48 hour immersion in a room temperature solution of 5% salt, 1% acetic acid.
  - f. Fin stock coating shall pass 2000 hours of the following: one week exposure in the prohesion chamber followed by one week of accelerated ultraviolet light testing. Prohesion chamber: the solution shall contain 3.5% sodium chloride and 0.35% ammonium sulfate. The exposure cycle is one hour of salt fog application at ambient followed by one hour drying at 95°F (35°C).

- h. Corrosion durability shall be confirmed through testing to be no less than 1000 hours salt spray per ASTM B117-90.
- J. (23 81 19.13.J.) Refrigerant Components:
1. Refrigerant circuit shall include the following control, safety, and maintenance features:
    - a. Thermostatic Expansion Valve (TXV) shall help provide optimum performance across the entire operating range. Shall contain removable power element to allow change out of power element and bulb without removing the valve body.
    - b. Refrigerant filter drier – Solid core design.
    - c. Service gage connections on suction and discharge lines.
    - d. Pressure gage access through a specially designed access port in the top panel of the unit.
  2. Compressors:
    - a. Unit shall use two tandem scroll compressors on single independent refrigeration circuit.
    - b. Units shall have single circuit and two stage cooling and contain two dual stage compressors.
    - c. Evaporator coils shall be a full active design to help better control comfort latent removal.
    - d. Compressor motors shall be cooled by refrigerant gas passing through motor windings.
    - e. Compressors shall be internally protected from high discharge temperature conditions.
    - f. Compressors shall be protected from an over-temperature and over-ampereage conditions by an internal, motor overload device.
    - g. Compressor shall be factory-mounted on rubber grommets.
    - h. Compressor motors shall have internal line break thermal, current overload and high pressure differential protection.
    - i. Crankcase heaters shall not be required for normal operating range, unless required by the manufacturer due to refrigerant charge limits.
- K. (23 81 19.13.K.) Return Air Filter Section:
1. Filters access is specified in the unit cabinet section of this specification.
  2. Filters shall be held in place by a pivoting filter tray, facilitating easy removal and installation.
  3. Shall consist of factory installed, low velocity, throw-away 2 in. thick fiberglass filters.
  4. Filters shall be standard, commercially available sizes.
  5. Only one size filter per unit is allowed.
- L. (23 81 19.13.L.) Evaporator Fan and Motor with EcoBlue™ Technology:
1. Direct Drive Evaporator fan motor:
    - a. Shall be a ECM motor design.
    - b. Shall have permanently lubricated bearings.
    - c. Shall have inherent automatic-reset thermal overload protection.
    - d. Shall have slow ramp up to speed capabilities.
    - e. Shall require no fan/motor belts for operation, adjustments and or initial fan speed set up.
    - f. Fan DC voltage set up on Unit Control Board can eliminate the need of removal of blower access door, required on conventional belt drive systems.
    - g. Shall be internally protected from electrical phase reversal and loss.
  2. Evaporator Fan:
    - a. Shall be easily set with dedicated selection switch and adjustment pot on unit control board or through SystemVu™ controller.
    - b. Shall provide two stage cooling capacity control, the indoor fan speed is automatically controlled to meet the code-compliant <66% low fan speed and 100% at full fan speed operation.
    - c. Blower fan shall be a Vane Axial fan design with 75% less moving parts than a conventional belt drive system.
    - d. Shall be constructed of a cast aluminum stator and high impact composite material on stator, rotor and air inlet casing.
    - e. Shall be a patented design with a corrosion resistant material and dynamically balanced.
    - f. Shall have slow ramp up to speed capabilities to help reduce sound and comfort issues typically associated with single speed belt drive systems.
    - g. Shall be a slide out design with removal of a few support brackets.
  3. Shall include an easily accessible Unit Control Board to conveniently and safely provide connection points for vital control functions such as: smoke detectors, phase monitor, gas controller, economizer, thermostat, DDC control options, and low, high and mixed air temperature switches. Controller shall also provide an intuitive means to adjust the indoor fan speed through a simple switch and pot adjustment design.
- M. (23 81 19.13.M.) Condenser Fans and Motors:
1. Condenser fan motors:
    - a. Shall be a totally enclosed motor.
    - b. Shall use permanently lubricated bearings.
    - c. Shall have inherent thermal overload protection with an automatic reset feature.
    - d. Shall use a shaft-down design on all sizes.

## 2. Condenser Fans:

- a. Shall be a direct-driven propeller type fan.
- b. Shall have galvalum blades riveted to steel spider that have corrosion-resistant properties and shall be dynamically balanced.

## N. (23 81 19.13.N.) Special Features Options and Accessories:

### 1. Integrated EconoMi\$er® IV, EconoMi\$er2, and EconoMi\$er X Low Leak rate models. (EconoMi\$er IV is only available as a field-installed accessory – this design only allows single speed fan operation.)

- a. Integrated, gear driven opposing modulating blade design type capable of simultaneous economizer and compressor operation.
- b. Independent modules for vertical or horizontal return configuration shall be available. Vertical return modules shall be available as a factory installed option.
- c. Damper blades shall be galvanized steel with composite gears. Plastic or composite blades on intake or return shall not be acceptable.
- d. Shall include all hardware and controls to provide free cooling with outdoor air when temperature and/or humidity are below setpoints.
- e. Shall be equipped with gear driven dampers for both the outdoor ventilation air and the return air for positive air stream control.
- f. Standard leak rate shall be equipped with dampers not to exceed 2% leakage at 1 in. wg pressure differential.
- g. Economizer controller on EconoMi\$er IV models shall be Honeywell W7212 that provides:
  - 1) Combined minimum and DCV maximum damper position potentiometers with compressor staging relay.
  - 2) Functions with solid-state analog enthalpy or dry bulb changeover control sensing.
  - 3) LED indicators for: when free cooling is available, when module is in DCV mode, when exhaust fan contact is closed.
- h. Economizer controller on EconoMi\$er X models shall be the Honeywell W7220 that provides:
  - 1) 2-line LCD interface screen for setup, configuration and troubleshooting.
  - 2) On-board Fault Detection and Diagnostics (FDD) that senses and alerts when the economizer is not operating properly, per California Title 24, ASHRAE 90.1 and IECC<sup>1</sup>.
  - 3) Sensor failure loss of communication identification.

### 4) Automatic sensor detection.

- 5) Capabilities for use with multiple-speed or single speed indoor fan systems.
- 6) Utilize digital sensors: Dry bulb and Enthalpy.

### i. Economizer controller on EconoMi\$er 2 models with SystemVu™ controls shall be a 4 to 20mA design controlled directly by the controller. SystemVu controller meets California Title 24, ASHRAE 90.1 and IECC Fault Detection and Diagnostic (FDD) requirements.

- j. Shall be capable of introducing up to 100% outdoor air.
- k. Shall be equipped with a barometric relief damper capable of relieving up to 100% return air and contain seals that meet ASHRAE 90.1 requirements.
- l. Shall be designed to close damper(s) during loss-of-power situations with spring return built into motor.
- m. Dry bulb outdoor air temperature sensor shall be provided as standard. Enthalpy sensor is also available on factory-installed economizers only. Outdoor air sensor setpoint shall be adjustable and shall range from 40°F to 100°F (4°C to 38°C). Additional sensor options shall be available as accessories.
- n. The economizer controller shall also provide control of an accessory power exhaust unit function. Factory set at 100%, with a range of 0% to 100%.
- o. The economizer shall maintain minimum airflow into the building during occupied period and provide design ventilation rate for full occupancy.
- p. Dampers shall be completely closed when the unit is in the unoccupied mode.
- q. Economizer controller shall accept a 2 to 10 Vdc CO<sub>2</sub> sensor input for IAQ/DCV control. In this mode, dampers shall modulate the outdoor air damper to provide ventilation based on the sensor input.
- r. Compressor lockout temperature on W7220 control is adjustable from -45°F to 80°F (-43°C to 27°C), set at a factory default of 32°F (0°C). W7212 control opens at 35°F (2°C) and closes at 50°F (10°C).
- s. Actuator shall be direct coupled to economizer gear. No linkage arms or control rods shall be acceptable.
- t. Economizer controller shall provide indications when in free cooling mode, in the DCV mode, or the exhaust fan contact is closed.

1. IECC is a registered trademark of the International Code Council, Inc.

2. Integrated EconoMi\$er®2, and EconoMi\$er X Ultra Low Leak rate models.
  - a. Integrated, gear driven opposing modulating blade design type capable of simultaneous economizer and compressor operation.
  - b. Independent modules for vertical or horizontal return configuration shall be available. Vertical return modules shall be available as a factory installed option.
  - c. Damper blades shall be galvanized steel with composite gears. Plastic or composite blades on intake or return shall not be acceptable.
  - d. Shall include all hardware and controls to provide free cooling with outdoor air when temperature and/or humidity are below set-points.
  - e. Shall be equipped with gear driven dampers for both the outdoor ventilation air and the return air for positive air stream control.
  - f. Ultra Low Leak design meets California Title 24 section 140.4 and ASHRAE 90.1 requirements for 4 cfm per sq. ft on the outside air dampers and 10 cfm per sq. ft on the return dampers.
  - g. Economizer controller on EconoMi\$er X models shall be the Honeywell W7220 that provides:
    - 1) 2-line LCD interface screen for setup, configuration and troubleshooting.
    - 2) On-board Fault Detection and Diagnostics (FDD) that senses and alerts when the economizer is not operating properly, per California Title 24, ASHRAE 90.1 and IECC.
    - 3) Sensor failure loss of communication identification.
    - 4) Automatic sensor detection.
    - 5) Capabilities for use with multiple-speed indoor fan systems.
    - 6) Utilize digital sensors: Dry bulb and Enthalpy.
  - h. Economizer controller on EconoMi\$er 2 models with SystemVu™ controls shall be a 4-20mA design controlled directly by the controller. SystemVu controller meets California Title 24, ASHRAE 90.1 and IECC Fault Detection and Diagnostic (FDD) requirements.
  - i. Shall be capable of introducing up to 100% outdoor air.
  - j. Shall be equipped with a barometric relief damper capable of relieving up to 100% return air and contain seals that meet ASHRAE 90.1 requirements.
  - k. Shall be designed to close damper(s) during loss-of-power situations with spring return built into motor.
1. Dry bulb outdoor air temperature sensor shall be provided as standard. Enthalpy sensor is also available on factory-installed economizers only. Outdoor air sensor setpoint shall be adjustable and shall range from 40°F to 100°F (4°C to 38°C). Additional sensor options shall be available as accessories.
  - m. The economizer controller shall also provide control of an accessory power exhaust unit function. Factory set at 100%, with a range of 0% to 100%.
  - n. The economizer shall maintain minimum airflow into the building during occupied period and provide design ventilation rate for full occupancy.
  - o. Dampers shall be completely closed when the unit is in the unoccupied mode.
  - p. Economizer controller shall accept a 2 to 10 vdc CO<sub>2</sub> sensor input for IAQ/DCV control. In this mode, dampers shall modulate the outdoor air damper to provide ventilation based on the sensor input.
  - q. Compressor lockout temperature on W7220 control is adjustable from -45°F to 80°F (-43°C to 27°C), set at a factory default of 32°F (0°C). W7212 control opens at 35°F (2°C) and closes at 50°F (10°C).
  - r. Actuator shall be direct coupled to economizer gear. No linkage arms or control rods shall be acceptable.
  - s. Economizer controller shall provide indications when in free cooling mode, in the DCV mode, or the exhaust fan contact is closed.
3. Two-Position Damper (Field-installed only):
  - a. Damper shall be a Two-Position Damper. Damper travel shall be from the full closed position to the field adjustable %-open setpoint.
  - b. Damper shall include adjustable damper travel from 25% to 100% (full open).
  - c. Damper shall include single or dual blade, gear driven dampers and actuator motor.
  - d. Actuator shall be direct coupled to damper gear. No linkage arms or control rods shall be acceptable.
  - e. Damper will admit up to 100% outdoor air for applicable rooftop units.
  - f. Damper shall close upon indoor (evaporator) fan shutoff and/or loss of power.
  - g. The damper actuator shall plug into the rooftop unit's wiring harness plug. No hard wiring shall be required.
  - h. Outside air hood shall include aluminum water entrainment filter.
4. Manual damper (Field-installed only):
  - a. Manual damper package shall consist of damper, air inlet screen, and rain hood



- which can be preset to admit up to 25 or 50% outdoor air for year round ventilation.
5. Humidi-MiZer® Adaptive Dehumidification System:
    - a. The Humidi-MiZer Adaptive Dehumidification System shall be factory installed and shall provide greater dehumidification of the occupied space by two modes of dehumidification operations in addition to its normal design cooling mode:
      - 1) Subcooling mode further sub cools the hot liquid refrigerant leaving the condenser coil when both temperature and humidity in the space are not satisfied.
      - 2) Hot gas reheat mode shall mix a portion of the hot gas from the discharge of the compressor with the hot liquid refrigerant leaving the condenser coil to create a two-phase heat transfer in the system, resulting in a neutral leaving air temperature when only humidity in the space is not satisfied.
      - 3) Includes low ambient controller.
  6. Low Ambient Control Package:
    - a. Controller shall control coil head pressure by condenser fan speed modulation or condenser fan cycling and wind baffles.
    - b. Shall consist of solid-state control and condenser coil temperature sensor to maintain condensing temperature between 90°F (32°C) and 110°F (43°C) at outdoor ambient temperatures down to 0°F (-18°C).
  7. Propane Gas Conversion Kit:
    - a. Package shall contain all the necessary hardware and instructions to convert a standard natural gas unit for use with liquefied propane, up to 2000 ft (610 m) elevation.
    - b. Additional accessory kits may be required for applications above 2000 ft (610 m) elevation.
  8. Flue Shield (08-14 sizes only):
    - a. Flue shield shall provide protection from the hot sides of the gas flue hood.
  9. Condenser Coil Hail Guard Assembly:
    - a. Shall protect against damage from hail.
    - b. Shall be either hood style or louvered.
  10. Unit-Mounted, Non-Fused Disconnect Switch (Available on 7.5 to 12.5 ton units with MOCPs of 80 amps or less, or 15 ton units with MOCPs of 100 amps or less):
    - a. Switch shall be factory installed, internally mounted.
    - b. National Electric Code (NEC) and UL approved non-fused switch shall provide unit power shutoff.
    - c. Shall be accessible from outside the unit.
  - d. Shall provide local shutdown and lockout capability.
  - e. Sized only for the unit as ordered from the factory. Does not accommodate field-installed devices.
11. Convenience Outlet:
    - a. Powered convenience outlet.
      - 1) Outlet shall be powered from main line power to the rooftop unit.
      - 2) Outlet shall be powered from line side or load side of disconnect by installing contractor, as required by code. If outlet is powered from load side of disconnect, unit electrical ratings shall be UL certified and rated for additional outlet amperage.
      - 3) Outlet shall be factory-installed and internally mounted with easily accessible 115-v female receptacle.
      - 4) Outlet shall include 15 amp GFI receptacles with independent fuse protection.
      - 5) Voltage required to operate convenience outlet shall be provided by a factory installed step-down transformer.
      - 6) Outlet shall be accessible from outside the unit.
      - 7) Outlet shall include a field installed “Wet in Use” cover.
    - b. Factory-Installed Non-Powered convenience outlet.
      - 1) Outlet shall be powered from a separate 115/120v power source.
      - 2) A transformer shall not be included.
      - 3) Outlet shall be factory-installed and internally mounted with easily accessible 115-v female receptacle.
      - 4) Outlet shall include 15 amp GFI receptacles with independent fuse protection.
      - 5) Outlet shall be accessible from outside the unit.
      - 6) Outlet shall include a field installed “Wet in Use” cover.
    - c. Field-Installed Non-Powered convenience outlet.
      - 1) Outlet shall be powered from a separate 115/120v power source.
      - 2) A transformer shall not be included.
      - 3) Outlet shall be field-installed and internally mounted with easily accessible 115-v female receptacle.
      - 4) Outlet shall include 20 amp GFI receptacles. This kit provides a flexible installation method which allows code compliance for height requirements of the GFCI outlet from the finished roof surface as well as

the capability to relocate the outlet to a more convenient location.

- 5) Outlet shall be accessible from outside the unit.
  - 6) Outlet shall include a field installed “Wet in Use” cover.
12. Flue Discharge Deflector:
    - a. Flue discharge deflector shall direct unit exhaust vertically instead of horizontally.
    - b. Deflector shall be defined as a “natural draft” device by the National Fuel and Gas (NFG) code.
  13. Thru-the-Base Connectors:
    - a. Kits shall provide connectors to permit gas and electrical connections to be brought to the unit through the unit basepan.
    - b. Minimum of four connection locations per unit.
  14. Supply Duct Cover (size 16 only):
    - a. Required when field converting the factory standard vertical duct supply to horizontal duct supply configuration. One required per unit.
  15. Propeller Power Exhaust:
    - a. Power exhaust shall be used in conjunction with an integrated economizer.
    - b. Independent modules for vertical or horizontal return configurations shall be available.
    - c. Horizontal power exhaust shall be mounted in return ductwork.
    - d. Power exhaust shall be controlled by economizer controller operation. Exhaust fans shall be energized when dampers open past the 0 to 100% adjustable setpoint on the economizer control.
  16. Roof Curbs (Vertical):
    - a. Full perimeter roof curb with exhaust capability providing separate air streams for energy recovery from the exhaust air without supply air contamination.
    - b. Formed galvanized steel with wood nailer strip and shall be capable of supporting entire unit weight.
    - c. Permits installation and securing of ductwork to curb prior to mounting unit on the curb.
  17. High Altitude Gas Conversion Kit:
    - a. Package shall contain all the necessary hardware and instructions to convert a standard natural gas unit to operate from 2000 to 7000 ft (610 to 2134 m) elevation with natural gas or from 0 to 7000 ft (0 to 2134 m) elevation with liquefied propane.
  18. Outdoor Air Enthalpy Sensor:
    - a. The outdoor air enthalpy sensor shall be used to provide single enthalpy control.
  19. Return Air Enthalpy Sensor:
    - a. The return air enthalpy sensor shall be used in conjunction with an outdoor air enthalpy sensor to provide differential enthalpy control.
  20. Indoor Air Quality (CO<sub>2</sub>) Sensor:
    - a. Shall be able to provide demand ventilation indoor air quality (IAQ) control.
    - b. The IAQ sensor shall be available in duct mount, wall mount, or wall mount with LED display. The setpoint shall have adjustment capability.
  21. Smoke detectors (factory-installed only):
    - a. Shall be a Four-Wire Controller and Detector.
    - b. Shall be environmental compensated with differential sensing for reliable, stable, and drift-free sensitivity.
    - c. Shall use magnet-activated test/reset sensor switches.
    - d. Shall have tool-less connection terminal access.
    - e. Shall have a recessed momentary switch for testing and resetting the detector.
    - f. Controller shall include:
      - 1) One set of normally open alarm initiation contacts for connection to an initiating device circuit on a fire alarm control panel.
      - 2) Two Form-C auxiliary alarm relays for interface with rooftop unit or other equipment.
      - 3) One Form-C supervision (trouble) relay to control the operation of the Trouble LED on a remote test/reset station.
      - 4) Capable of direct connection to two individual detector modules.
      - 5) Can be wired to up to 14 other duct smoke detectors for multiple fan shut-down applications.
  22. Winter Start Kit:
    - a. Shall contain a bypass device around the low pressure switch.
    - b. Shall be required when mechanical cooling is required down to 25°F (-4°C).
    - c. Shall not be required to operate on an economizer when below an outdoor ambient of 40°F (4°C).
  23. Time Guard:
    - a. Shall prevent compressor short-cycling by providing a 5-minute delay (±2 minutes)

- before restarting a compressor after shut-down for any reason.
- b. One device shall be required per compressor.
24. Disconnect Switch Bracket (size 16 only):
- a. Provides a pre-engineered and sized mounting bracket for applications requiring a unit mounted fused and non-fused disconnect of greater than 100 amps. Bracket assures that no damage will occur to coils when mounting with screws and other fasteners.
25. Hinged Access Panels:
- a. Shall provide easy access through integrated quarter turn latches.
- b. Shall be on major panels of: filter, control box, fan motor, and compressor.
26. Condensate Overflow switch:
- a. This sensor and related controller monitors the condensate level in the drain pan and shuts down compression operation when overflow conditions occur. It includes:
- 1) Indicator light — solid red (more than 10 seconds on water contact – compressors disabled), blinking red (sensor disconnected).
  - 2) 10 second delay to break — eliminates nuisance trips from splashing or waves in pan (sensor needs 10 seconds of constant water contact before tripping).
  - 3) Disables the compressors operation when condensate plug is detected, but still allows fans to run for Economizer.
27. 4 in. MERV-13 Return Air filters:
- a. Factory option to upgrade standard unit filters to 4 in. MERV-13 filters. Filter media is securely fastened inside the filter frame on all four sides.
28. 4 in. filter rack kit:
- a. The 4 in. filter rack accessory kit is designed to hold 4 in. MERV-8 or MERV-13 filters. Filters not included in kit.
29. 2 in. MERV-13 Return Air filters:
- a. Accessory kit to field upgrade standard unit filters to 2 in. MERV-13 filters.
30. 2 in. MERV-8 Return Air filters:
- a. Accessory kit to field upgrade standard unit filters to 2 in. MERV-8 filters.
31. Phase Monitor Control:
- a. Shall monitor the sequence of three phase electrical system to provide a phase reversal protection.
- b. Shall monitor the three phase voltage inputs to provide a phase loss protection for the three phase device.
- c. Will work on either a Delta or Wye power connection.
32. Horn/Strobe Annunciator:
- a. Provides an audible/visual signaling device for use with factory-installed option or field installed accessory smoke detectors.
- 1) Requires installation of a field-supplied 24-v transformer suitable for 4.2 VA (AC) or 3.0 VA (DC) per horn/strobe accessory.
  - 2) Requires field-supplied electrical box, North American 1-gang box, 2 in. (51 mm) x 4 in. (102 mm).
  - 3) Shall have a clear colored lens.
33. UV-C ultraviolet lamp kit:
- a. High-output, low temperature ultraviolet lamp accessory. It includes:
- 1) 36 in. lamp, interlock switch, mounting brackets, necessary wires, wire ties, screws and labels to field install kit in unit return air plenum.
  - 2) Separate dedicated 115v power source required.
  - 3) UV-C kit can not be used on units with Humidi-MiZer® system.
34. High Short Circuit Current Rating (SCCR) protection:
- a. Factory-installed option provides high short circuit current protection to each compressor, plus all indoor and outdoor fan motors of 10 kA against high potential fault current situations. (Standard unit comes with 5 kA rating.)
- b. This option is not available with factory installed Non-Fused Disconnect, Humidi-MiZer system, Low Ambient controls, Phase loss monitor/protection and 575 Volt models.

Note about this specification:

This specification is in the "Masterformat" as published by the Construction Specification Institute. Please feel free to copy this specification directly into your building spec.



## Cooling Only/Electric Heat Packaged Rooftop

### HVAC Guide Specifications

Size Range: **7.5 to 15 Nominal Tons**

Carrier Model Number: **50FC\*08-16**

#### Part 1 — (23 06 80) Schedules for Decentralized HVAC Equipment

1.01 (23 06 80.13) Decentralized Unitary HVAC Equipment Schedule:

- A. (23 06 80.13.A.) Rooftop unit (RTU) schedule:
  - 1. Schedule is per the project specification requirements.

#### Part 2 — (23 07 16) HVAC equipment insulation

2.01 (23 07 16.13) Decentralized, Rooftop Units:

- A. (23 07 16.13.A.) Evaporator fan compartment:
  - 1. Interior cabinet surfaces shall be insulated with a minimum 1/2 in. thick, minimum 1 1/2 lb density, flexible fiberglass insulation bonded with a phenolic binder, neoprene coated on the air side.
  - 2. Insulation and adhesive shall meet NFPA 90A requirements for flame spread and smoke generation.
- B. (23 07 16.13.B.) Electric Heat Compartment:
  - 1. Aluminum foil-faced fiberglass insulation shall be used.
  - 2. Insulation and adhesive shall meet NFPA 90A requirements for flame spread and smoke generation.

#### Part 3 — (23 09 13) Instrumentation and control devices for HVAC

3.01 (23 09 13.23) Sensors and Transmitters:

- A. (23 09 13.23.A.) Thermostats:
  - 1. Thermostat must
    - a. energize both "W" and "G" when calling for heat.
    - b. have capability to energize 1 or 2 stages of cooling, and 2 different stages of heating.
    - c. include capability for occupancy scheduling.

#### Part 4 — (23 09 23) Direct Digital Control system for HVAC

4.01 (23 09 23.13) Decentralized, Rooftop Units:

- A. (23 09 23.13.A.) SystemVu™ intelligent integrated Direct Digital Control (DDC) shall provide:
  - 1. Integrated unit operation for comfort cooling, heating ventilation as well as all monitoring,

recording and reporting capabilities. Controller shall also provide diagnostics and alarms of abnormal unit operation through the controller. Controller shall have an intuitive user display and be able to be used in a standalone operation or via building automation system (BAS).

- 2. Quick Unit Status LEDs of: RUN – meaning all systems are go, ALERT – that indicates there is currently a non-critical issue with the unit, like filters need to be replaced and FAULT – that indicates the unit has a critical issue and will possibly shut down.
- 3. Six large navigation keys for easy access. Navigation keys shall consist of: TEST, BACK, ENTER, and MENU along with UP and DOWN arrows.
- 4. Full back lit user display with 4 line by 30 character text capabilities. Display menu shall be designed to provide guided major menus and sub menus main menus provided below:
  - a. Shutdown Unit
  - b. Run Status
  - c. Settings
  - d. Alerts/Faults
  - e. Service
  - f. Inputs
  - g. Outputs
  - h. USB
- 5. The capability for standalone operation with conventional thermostat/sensor or use with building automation systems (BAS) of Carrier i-Vu®, BACnet MS/PT and Carrier Comfort Network® (CCN) systems. No special modules or boards are required for these capabilities. Has the capability to work with Equipment Touch™ and System Touch™ devices and ZS Sensors.
- 6. The ability to read refrigerant pressures at display or via BAS network of; Discharge Pressure and Suction Pressure. The need for traditional refrigerant gages is not required.
- 7. USB Data Port for flash drive interaction. This will allow the transfer of data for uploads, downloads, perform software upgrades, backup and restore data and file transfer data such as component number of starts and run hours.
- 8. Reverse Rotation Protection of compressors if field three phase wiring is misapplied.
- 9. Provide Service Capabilities of:
  - a. Auto run test
  - b. Manual run test
  - c. Component run hours and starts
  - d. Commissioning reports
  - e. Data logging
  - f. Alarm history

10. Economizer control and diagnostics. Set up economizer operation, receive feedback from actuator. Also meets the most recent California Title 24, ASHRAE 90.1 and IECC Fault Detection and Diagnostic (FDD) requirements.
11. Unit cooling operation down to 40°F (4°C) [0°F (-18°C) for size 14 models].
12. Controller shall have easy access connections around the controller perimeter area and consist of Mate-N-Lok, terminal block and RJ style modular jack connections.
13. 365 day real time clock, 20 holiday schedules along with occupied and unoccupied scheduling.
14. Auto-Recognition for easy installation and commissioning of devices like economizers, space sensors, etc.
15. A 5°F temperature difference between cooling and heating set points to meet the latest ASHRAE 90.1 Energy Standard.
16. Contain return air sensor, supply air sensor and outdoor air sensor to help monitor and provide data for the unit comfort operation, diagnostic and alarms.
17. Use of Carrier's field accessory hand-held Navigator™ display, Equipment Touch and System Touch devices.
18. Units with the factory-installed Humidi-MiZer® system option are capable of providing multiple modes of improved dehumidification as a variation of the normal cooling cycle.
19. Supply Air Tempering control operates the gas or electric heat to maintain a minimum supply air temperature during conditions where very cold outdoor air causes the supply air temperature to fall below the configured Supply Air Tempering Setpoint. This occurs during periods where DCV is active and increasing the amount of outdoor air or in cases where the system is operating at very low airflow and the calculated economizer position has increased to maintain a constant ventilation rate.
20. Demand limiting in SystemVu™ is achieved through set point expansion. The systems heating and cooling set points are expanded in steps or levels. The degree to which the set points may be expanded is defined by the 6 demand level offsets and the 2 commanded demand limit levels.
21. 3-year limited part warranty.

## **Part 5 — (23 09 33) Electric and Electronic Control System for HVAC**

### 5.01 (23 09 33.13) Decentralized, Rooftop Units:

#### A. (23 09 33.13.A.) General:

1. Shall be complete with self-contained low-voltage control circuit protected by a resettable circuit

breaker on the 24-v transformer side. Transformer shall have 75VA capability.

2. Shall utilize color-coded wiring.
3. Shall include a Unit Control Board to conveniently and safely provide connection points for vital control functions such as: smoke detectors, phase monitor, economizer, thermostat, DDC control options, and low and high pressure switches. Controller shall also provide an intuitive means to adjust the indoor fan speed through a simple switch and pot adjustment design.
4. Unit shall include a minimum of one 8-pin screw terminal connection board for connection of control wiring.

#### B. (23 09 33.13.B.) Safeties:

1. Compressor over-temperature, over-current. High internal pressure differential.
2. Low pressure switch.
  - a. Low pressure switch shall use different color wire than the high pressure switch. The purpose is to assist the installer and service technician to correctly wire and or troubleshoot the rooftop unit.
3. High pressure switch.
  - a. High pressure switch shall use different color wire than the low pressure switch. The purpose is to assist the installer and service technician to correctly wire and or troubleshoot the rooftop unit.
4. Mixed air auto re-set temperature switch
  - a. When return air temperatures get the critical point that can cause compressor reliability issues, this switch will shut down compression only until the temperature raise accordingly. Switch opens at 60°F (16°C) and closes at 65°F (18°C).
5. Automatic reset, motor thermal overload protector.

## **Part 6 — (23 09 93) Sequence of Operations for HVAC Controls**

### 6.01 (23 09 93.13) Decentralized, Rooftop Units:

#### A. (23 09 93.13.A.) INSERT SEQUENCE OF OPERATION

## **Part 7 — (23 40 13) Panel Air Filters**

### 7.01 (23 40 13.13) Decentralized, Rooftop Units:

#### A. (23 40 13.13.A.) Standard filter section:

1. Shall consist of factory installed, low velocity, disposable 2 in. thick fiberglass filters of commercially available sizes.
2. Unit shall use only one filter size. Multiple sizes are not acceptable.
3. Filters shall be accessible through an access panel with “no-tool” removal as described in the unit cabinet section of this specification (23 81 19.13.G).

## Part 8 — (23 81 19) Self-Contained Air Conditioners

### 8.01 (23 81 19.13) Small-Capacity Self-Contained Air Conditioners:

#### A. (23 81 19.13.A.) General:

1. Outdoor, rooftop mounted, electrically controlled, heating and cooling unit utilizing fully hermetic scroll compressors for cooling duty and optional electric heat for heating duty.
2. Factory assembled, single-piece heating and cooling rooftop unit. Contained within the unit enclosure shall be all factory wiring, piping, controls, and special features required prior to field start-up.
3. Unit shall use Puron® (R-410A) refrigerant.
4. Unit shall be installed in accordance with the manufacturer's instructions.
5. Unit must be selected and installed in compliance with local, state, and federal codes.

#### B. (23 81 19.13.B.) Quality Assurance:

1. Unit meets ASHRAE 90.1 minimum efficiency requirements.
2. Unit shall be rated in accordance with AHRI Standards 340/360.
3. Unit shall be designed to conform to ASHRAE 15.
4. Unit shall be UL-tested and certified in accordance with ANSI Z21.47 Standards and UL-listed and certified under Canadian standards as a total package for safety requirements.
5. Insulation and adhesive shall meet NFPA 90A requirements for flame spread and smoke generation.
6. Unit casing shall be capable of withstanding 500 hour salt spray exposure per ASTM B117 (scribed specimen).
7. Unit shall be designed in accordance with ISO 9001, and shall be manufactured in a facility registered by ISO 9001:2015.
8. Roof curb shall be designed to conform to NRCA Standards.
9. Unit shall be subjected to a completely automated run test on the assembly line. The data for each unit will be stored at the factory, and must be available upon request.
10. Unit shall be designed in accordance with UL Standard 60335-2-40, including tested to withstand rain.
11. Unit shall be constructed to prevent intrusion of snow and tested to prevent snow intrusion into the control box up to 40 mph.
12. Unit shake tested to assurance level 1, ASTM D4169 to ensure shipping reliability.

#### C. (23 81 19.13.C.) Delivery, Storage, and Handling:

1. Unit shall be stored and handled per manufacturer's recommendations.

2. Lifted by crane requires either shipping top panel or spreader bars.
3. Unit shall only be stored or positioned in the upright position.

#### D. (23 81 19.13.D.) Project Conditions:

1. As specified in the contract.

#### E. (23 81 19.13.E.) Operating Characteristics:

1. Unit shall be capable of starting and running at 125°F (52°C) ambient outdoor temperature except 14 size models that are capable of starting and running at 120°F (49°C), meeting maximum load criteria of AHRI Standard 340/360 at ±10% voltage.
2. Compressor with standard controls shall be capable of operation down to 40°F (4°C) [0°F (-18°C) for size 14 models], ambient outdoor temperatures. Accessory winter start kit is necessary if mechanically cooling at ambient temperatures down to 25°F (-4°C) or 0°F (-18°C).
3. Unit shall discharge supply air vertically or horizontally as shown on contract drawings.
4. Unit shall be factory configured for vertical supply and return configurations.
5. Unit shall be field convertible from vertical to horizontal airflow on all models. No special kit required except on 16 size models that requires a Supply Duct Kit field installation for horizontal air flow.
6. Unit shall be capable of mixed operation: vertical supply with horizontal return or horizontal supply with vertical return.

#### F. (23 81 19.13.F.) Electrical Requirements:

1. Main power supply voltage, phase, and frequency must match those required by the manufacturer.

#### G. (23 81 19.13.G.) Unit Cabinet:

1. Unit cabinet shall be constructed of galvanized steel, and shall be bonderized and coated with a prepainted baked enamel finish on all externally exposed surfaces.
2. Unit cabinet exterior paint shall be: film thickness, (dry) 0.003 in. minimum, gloss (per ASTM D523, 60°F/16°C): 60, Hardness: H-2H Pencil hardness.
3. Evaporator fan compartment interior cabinet insulation shall conform to AHRI Standards 340/360 minimum exterior sweat criteria. Interior surfaces shall be insulated with a minimum 1/2 in. thick, 1 lb density, flexible fiberglass insulation, neoprene coated on the air side. Aluminum foil-faced fiberglass insulation shall be used in the heat compartment.
4. Base of unit shall have a minimum of four locations for thru-the-base gas and electrical connections (factory-installed or field-installed), standard.

5. Base Rail:
  - a. Unit shall have base rails on a minimum of 2 sides.
  - b. Holes shall be provided in the base rails for rigging shackles to facilitate maneuvering and overhead rigging.
  - c. Holes shall be provided in the base rail for moving the rooftop by fork truck.
  - d. Base rail shall be a minimum of 16 gage thickness.
6. Condensate pan and connections:
  - a. Shall be a sloped condensate drain pan made of a corrosion resistant material.
  - b. Shall comply with ASHRAE Standard 62.
  - c. Shall use a 3/4 in. 14 NPT drain connection, possible either through the bottom or side of the drain pan. Connection shall be made per manufacturer's recommendations.
7. Top panel:
  - a. Shall be a single piece top panel on 08-14 models and two piece on 16 size models.
8. Electrical Connections:
  - a. All unit power wiring shall enter unit cabinet at a single, factory prepared, knockout location.
  - b. Thru-the-base capability.
    - 1) Standard unit shall have a thru-the-base electrical location(s) using a raised, embossed portion of the unit basepan.
    - 2) Optional, factory approved, water-tight connection method must be used for thru-the-base electrical connections.
    - 3) No basepan penetration, other than those authorized by the manufacturer, is permitted.
9. Component access panels (standard):
  - a. Cabinet panels shall be easily removable for servicing.
  - b. Unit shall have one factory installed, tool-less, removable, filter access panel.
  - c. Panels covering control box, indoor fan, indoor fan motor, gas components (where applicable), and compressors shall have molded composite handles.
  - d. Handles shall be UV modified, composite. They shall be permanently attached, and recessed into the panel.
  - e. Screws on the vertical portion of all removable access panel shall engage into heat resistant, molded composite collars.
  - f. Collars shall be removable and easily replaceable using manufacturer recommended parts.
- H. (23 81 19.13.H.) Coils:
  1. Standard Aluminum Fin-Copper Tube Coils:
    - a. Standard evaporator and condenser coils shall have aluminum lanced plate fins mechanically bonded to seamless internally grooved copper tubes with all joints brazed.
    - b. Evaporator coils shall be leak tested to 150 psig, pressure tested to 450 psig, and qualified to UL 1995 burst test at 1775 psig.
    - c. Condenser coils shall be leak tested to 150 psig, pressure tested to 650 psig, and qualified to UL 1995 burst test at 1980 psig.
  2. Optional Pre-coated aluminum-fin condenser coils:
    - a. Shall have a durable epoxy-phenolic coating to provide protection in mildly corrosive coastal environments.
    - b. Coating shall be applied to the aluminum fin stock prior to the fin stamping process to create an inert barrier between the aluminum fin and copper tube.
    - c. Epoxy-phenolic barrier shall minimize galvanic action between dissimilar metals.
    - d. Corrosion durability of fin stock shall be confirmed through testing to be no less than 1000 hours salt spray per ASTM B117-90.
    - e. Corrosion durability of fin stock shall be confirmed through testing to have no visible corrosion after 48 hour immersion in a room temperature solution of 5% salt, 1% acetic acid.
    - f. Fin stock coating shall pass 2000 hours of the following: one week exposure in the prohesion chamber followed by one week of accelerated ultraviolet light testing. Prohesion chamber: the solution shall contain 3.5% sodium chloride and 0.35% ammonium sulfate. The exposure cycle is one hour of salt fog application at ambient followed by one hour drying at 95°F (35°C).
  3. Optional Copper-fin evaporator and condenser coils:
    - a. Shall be constructed of copper fins mechanically bonded to copper tubes and copper tube sheets.
    - b. Galvanized steel tube sheets shall not be acceptable.
    - c. A polymer strip shall prevent coil assembly from contacting the sheet metal coil pan to minimize potential for galvanic corrosion between coil and pan.
  4. Optional E-coated aluminum-fin evaporator and condenser coils:
    - a. Shall have a flexible epoxy polymer coating uniformly applied to all coil surface areas without material bridging between fins.

- b. Coating process shall ensure complete coil encapsulation of tubes, fins and headers.
  - c. Color shall be high gloss black with gloss per ASTM D523-89.
  - d. Uniform dry film thickness from 0.8 to 1.2 mil on all surface areas including fin edges.
  - e. Superior hardness characteristics of 2H per ASTM D3363-92A and cross-hatch adhesion of 4B-5B per ASTM D3359-93.
  - f. Impact resistance shall be up to 160 in.-lb (ASTM D2794-93).
  - g. Humidity and water immersion resistance shall be up to minimum 1000 and 250 hours respectively (ASTM D2247-92 and ASTM D870-92).
  - h. Corrosion durability shall be confirmed through testing to be no less than 1000 hours salt spray per ASTM B117-90.
- I. (23 81 19.13.I.) Refrigerant Components:
- 1. Refrigerant circuit shall include the following control, safety, and maintenance features:
    - a. Thermostatic Expansion Valve (TXV) shall help provide optimum performance across the entire operating range. Shall contain removable power element to allow change out of power element and bulb without removing the valve body.
    - b. Refrigerant filter drier – Solid core design.
    - c. Service gage connections on suction and discharge lines.
    - d. Pressure gage access through a specially designed access port in the top panel of the unit.
  - 2. Compressors:
    - a. Unit shall use two tandem scroll compressors on single independent refrigeration circuit.
    - b. Units shall have single circuit and two stage cooling and contain two dual stage compressors.
    - c. Evaporator coils shall be a full active design to help better control comfort latent removal.
    - d. Compressor motors shall be cooled by refrigerant gas passing through motor windings.
    - e. Compressors shall be internally protected from high discharge temperature conditions.
    - f. Compressors shall be protected from an over-temperature and over-amperage conditions by an internal, motor overload device.
    - g. Compressor shall be factory mounted on rubber grommets.
    - h. Compressor motors shall have internal line break thermal, current overload and high pressure differential protection.
- i. Crankcase heaters shall not be required for normal operating range, unless required by compressor manufacturer due to refrigerant charge limits.
  - j. Compressors shall be a two stage cooling capacity design.
- J. (23 81 19.13.J.) Return Air Filter Section:
- 1. Filters access is specified in the unit cabinet section of this specification.
  - 2. Filters shall be held in place by a pivoting filter tray, facilitating easy removal and installation.
  - 3. Shall consist of factory installed, low velocity, throw-away 2 in. thick fiberglass filters.
  - 4. Filters shall be standard, commercially available sizes.
  - 5. Only one size filter per unit is allowed.
- K. (23 81 19.13.K.) Evaporator Fan and Motor with EcoBlue™ Technology:
- 1. Direct Drive Evaporator fan motor:
    - a. Shall be a ECM motor design.
    - b. Shall have permanently lubricated bearings.
    - c. Shall have inherent automatic-reset thermal overload protection.
    - d. Shall have slow ramp up to speed capabilities.
    - e. Shall require no fan/motor belts for operation, adjustments and or initial fan speed set up.
    - f. Fan DC voltage set up on Unit Control Board can eliminate the need of removal of blower access door, required on conventional belt drive systems.
    - g. Shall be internally protected from electrical phase reversal and loss.
  - 2. Evaporator Fan:
    - a. Shall be easily set with dedicated selection switch and adjustment pot on unit control board or through SystemVu™ controller.
    - b. Shall provide two stage cooling capacity control, the indoor fan speed is automatically controlled to meet the code-compliant <66% low fan speed and 100% at full fan speed operation.
    - c. Blower fan shall be a Vane Axial fan design with 75% less moving parts than a conventional belt drive system.
    - d. Shall be constructed of a cast aluminum stator and high impact composite material on stator, rotor and air inlet casing.
    - e. Shall be a patented / pending design with a corrosion resistant material and dynamically balanced.
    - f. Shall have slow ramp up to speed capabilities to help reduce sound and comfort issues typically associated with single speed belt drive systems.



- g. Shall be a slide out design with removal of a few support brackets.
- 3. Shall include an easily accessible Unit Control Board to conveniently and safely provide connection points for vital control functions such as: smoke detectors, phase monitor, gas controller, economizer, thermostat, DDC control options, and low, high and mixed air temperature switches. Controller shall also provide an intuitive means to adjust the indoor fan speed through a simple switch and pot adjustment design.
- L. (23 81 19.13.L.) Condenser Fans and Motors:
  - 1. Condenser fan motors:
    - a. Shall be a totally enclosed motor.
    - b. Shall use permanently lubricated bearings.
    - c. Shall have inherent thermal overload protection with an automatic reset feature.
    - d. Shall use a shaft-down design on all sizes.
  - 2. Condenser Fans:
    - a. Shall be a direct-driven propeller type fan.
    - b. Shall have galvalum blades riveted to steel spider that have corrosion-resistant properties and shall be dynamically balanced.
- M. (23 81 19.13.M.) Special Features Options and Accessories:
  - 1. Integrated EconoMi\$er® IV, EconoMi\$er2, and EconoMi\$er X Low Leak rate models. (EconoMi\$er IV is only available as a field-installed accessory – this design only allows single speed fan operation.)
    - a. Integrated, gear driven opposing modulating blade design type capable of simultaneous economizer and compressor operation.
    - b. Independent modules for vertical or horizontal return configuration shall be available. Vertical return modules shall be available as a factory installed option.
    - c. Damper blades shall be galvanized steel with composite gears. Plastic or composite blades on intake or return shall not be acceptable.
    - d. Shall include all hardware and controls to provide free cooling with outdoor air when temperature and/or humidity are below setpoints.
    - e. Shall be equipped with gear driven dampers for both the outdoor ventilation air and the return air for positive air stream control.
    - f. Standard leak rate shall be equipped with dampers not to exceed 2% leakage at 1 in. wg pressure differential.
    - g. Economizer controller on EconoMi\$er IV models shall be Honeywell W7212 that provides:
      - 1) Combined minimum and DCV maximum damper position potentiometers with compressor staging relay.
      - 2) Functions with solid-state analog enthalpy or dry bulb changeover control sensing.
      - 3) Contain LED indicates for: when free cooling is available, when module is in DCV mode, when exhaust fan contact is closed.
    - h. Economizer controller on EconoMi\$er X models shall be the Honeywell W7220 that provides:
      - 1) 2-line LCD interface screen for setup, configuration and troubleshooting.
      - 2) On-board Fault Detection and Diagnostics (FDD) that senses and alerts when the economizer is not operating properly, per California Title 24, ASHRAE 90.1 and IECC<sup>1</sup>.
      - 3) Sensor failure loss of communication identification.
      - 4) Automatic sensor detection.
      - 5) Capabilities for use with multiple-speed or single speed indoor fan systems.
      - 6) Utilize digital sensors: Dry bulb and Enthalpy.
    - i. Economizer controller on EconoMi\$er 2 models with SystemVu™ controls shall be a 4 to 20mA design controlled directly by the controller. SystemVu controller meets California Title 24, ASHRAE 90.1 and IECC Fault Detection and Diagnostic (FDD) requirements.
    - j. Shall be capable of introducing up to 100% outdoor air.
    - k. Shall be equipped with a barometric relief damper capable of relieving up to 100% return air and contain seals that meet ASHRAE 90.1 requirements.
    - l. Shall be designed to close damper(s) during loss-of-power situations with spring return built into motor.
    - m. Dry bulb outdoor air temperature sensor shall be provided as standard. Enthalpy sensor is also available on factory installed only. Outdoor air sensor setpoint shall be adjustable and shall range from 40°F to 100°F (4°C to 38°C). Additional sensor options shall be available as accessories.
    - n. The economizer controller shall also provide control of an accessory power exhaust unit function. Factory set at 100%, with a range of 0% to 100%.
    - o. The economizer shall maintain minimum air-flow into the building during occupied period and provide design ventilation rate for full occupancy.

1. IECC is a registered trademark of the International Code Council, Inc.

- p. Dampers shall be completely closed when the unit is in the unoccupied mode.
  - q. Economizer controller shall accept a 2 to 10 vdc CO<sub>2</sub> sensor input for IAQ/DCV control. In this mode, dampers shall modulate the outdoor air damper to provide ventilation based on the sensor input.
  - r. Compressor lockout temperature on W7220 control is adjustable from -45°F to 80°F (-43°C to 27°C), set at a factory default of 32°F (0°C). W7212 control opens at 35°F (2°C) and closes at 50°F (10°C).
  - s. Actuator shall be direct coupled to economizer gear. No linkage arms or control rods shall be acceptable.
  - t. Economizer controller shall provide indications when in free cooling mode, in the DCV mode, or the exhaust fan contact is closed.
2. Integrated EconoMi\$er®2, and EconoMi\$er X Ultra Low Leak rate models.
- a. Integrated, gear driven opposing modulating blade design type capable of simultaneous economizer and compressor operation.
  - b. Independent modules for vertical or horizontal return configuration shall be available. Vertical return modules shall be available as a factory-installed option.
  - c. Damper blades shall be galvanized steel with composite gears. Plastic or composite blades on intake or return shall not be acceptable.
  - d. Shall include all hardware and controls to provide free cooling with outdoor air when temperature and/or humidity are below setpoints.
  - e. Shall be equipped with gear driven dampers for both the outdoor ventilation air and the return air for positive air stream control.
  - f. Ultra Low Leak design meets California Title 24 section 140.4 and ASHRAE 90.1 requirements for 4 cfm per sq ft on the outside air dampers and 10 cfm per sq ft on the return dampers.
  - g. Economizer controller on EconoMi\$er X models shall be the Honeywell W7220 that provides:
    - 1) 2-line LCD interface screen for setup, configuration and troubleshooting.
    - 2) On-board Fault Detection and Diagnostics (FDD) that senses and alerts when the economizer is not operating properly, per California Title 24, ASHRAE 90.1 and IECC.
    - 3) Sensor failure loss of communication identification.
    - 4) Automatic sensor detection.
    - 5) Capabilities for use with multiple-speed indoor fan systems.
  - 6) Utilize digital sensors: Dry bulb and Enthalpy.
  - h. Economizer controller on EconoMi\$er 2 models with SystemVu™ controls shall be a 4-20mA design controlled directly by the controller. SystemVu controller meets California Title 24, ASHRAE 90.1 and IECC Fault Detection and Diagnostic (FDD) requirements.
  - i. Shall be capable of introducing up to 100% outdoor air.
  - j. Shall be equipped with a barometric relief damper capable of relieving up to 100% return air and contain seals that meet ASHRAE 90.1 requirements.
  - k. Shall be designed to close damper(s) during loss-of-power situations with spring return built into motor.
  - l. Dry bulb outdoor air temperature sensor shall be provided as standard. Enthalpy sensor is also available on factory installed only. Outdoor air sensor setpoint shall be adjustable and shall range from 40°F to 100°F (4°C to 38°C). Additional sensor options shall be available as accessories.
  - m. The economizer controller shall also provide control of an accessory power exhaust unit function. Factory set at 100%, with a range of 0% to 100%.
  - n. The economizer shall maintain minimum airflow into the building during occupied period and provide design ventilation rate for full occupancy.
  - o. Dampers shall be completely closed when the unit is in the unoccupied mode.
  - p. Economizer controller shall accept a 2 to 10 vdc CO<sub>2</sub> sensor input for IAQ/DCV control. In this mode, dampers shall modulate the outdoor air damper to provide ventilation based on the sensor input.
  - q. Compressor lockout temperature on W7220 control is adjustable from -45°F to 80°F (-43°C to 27°C), set at a factory default of 32°F (0°C). W7212 control opens at 35°F (2°C) and closes at 50°F (10°C).
  - r. Actuator shall be direct coupled to economizer gear. No linkage arms or control rods shall be acceptable.
  - s. Economizer controller shall provide indications when in free cooling mode, in the DCV mode, or the exhaust fan contact is closed.
3. Two-Position Damper (field-installed only):
- a. Damper shall be a Two-Position Damper. Damper travel shall be from the full closed position to the field adjustable %-open setpoint.

- b. Damper shall include adjustable damper travel from 25% to 100% (full open).
  - c. Damper shall include single or dual blade, gear driven dampers and actuator motor.
  - d. Actuator shall be direct coupled to damper gear. No linkage arms or control rods shall be acceptable.
  - e. Damper will admit up to 100% outdoor air for applicable rooftop units.
  - f. Damper shall close upon indoor (evaporator) fan shutoff and/or loss of power.
  - g. The damper actuator shall plug into the rooftop unit's wiring harness plug. No hard wiring shall be required.
  - h. Outside air hood shall include aluminum water entrainment filter.
4. Manual damper (field-installed only):
- a. Manual damper package shall consist of damper, air inlet screen, and rain hood which can be preset to admit up to 25% or 50% outdoor air for year round ventilation.
5. Humidi-MiZer Adaptive Dehumidification System:
- a. The Humidi-MiZer<sup>®</sup> Adaptive Dehumidification System shall be factory installed and shall provide greater dehumidification of the occupied space by two modes of dehumidification operations in addition to its normal design cooling mode:
    - 1) Subcooling mode further sub cools the hot liquid refrigerant leaving the condenser coil when both temperature and humidity in the space are not satisfied.
    - 2) Hot gas reheat mode shall mix a portion of the hot gas from the discharge of the compressor with the hot liquid refrigerant leaving the condenser coil to create a two-phase heat transfer in the system, resulting in a neutral leaving air temperature when only humidity in the space is not satisfied.
    - 3) Includes low ambient controller.
6. Low Ambient Control Package:
- a. Controller shall control coil head pressure by condenser fan speed modulation or condenser fan cycling and wind baffles.
  - b. Shall consist of solid-state control and condenser coil temperature sensor to maintain condensing temperature between 90°F (32°C) and 110°F (43°C) at outdoor ambient temperatures down to 0°F (-18°C).
7. Condenser Coil Hail Guard Assembly:
- a. Shall protect against damage from hail.
  - b. Shall be either hood style or louvered.
8. Unit-Mounted, Non-Fused Disconnect Switch (Available on 7.5 to 12.5 ton units with MOCPS of 80 amps or less, or 15 ton units with MOCPS of 100 amps or less):
- a. Switch shall be factory installed, internally mounted.
  - b. National Electric Code (NEC) and UL approved non-fused switch shall provide unit power shutoff.
  - c. Shall be accessible from outside the unit.
  - d. Shall provide local shutdown and lockout capability.
  - e. Sized only for the unit as ordered from the factory. Does not accommodate field-installed devices.
9. Convenience Outlet:
- a. Powered convenience outlet.
    - 1) Outlet shall be powered from main line power to the rooftop unit.
    - 2) Outlet shall be powered from line side or load side of disconnect by installing contractor, as required by code. If outlet is powered from load side of disconnect, unit electrical ratings shall be UL certified and rated for additional outlet amperage.
    - 3) Outlet shall be factory-installed and internally mounted with easily accessible 115-v female receptacle.
    - 4) Outlet shall include 15 amp GFI receptacles with independent fuse protection.
    - 5) Voltage required to operate convenience outlet shall be provided by a factory installed step-down transformer.
    - 6) Outlet shall be accessible from outside the unit.
    - 7) Outlet shall include a field installed "Wet in Use" cover.
  - b. Factory-Installed Non-Powered convenience outlet.
    - 1) Outlet shall be powered from a separate 115/120v power source.
    - 2) A transformer shall not be included.
    - 3) Outlet shall be factory-installed and internally mounted with easily accessible 115-v female receptacle.
    - 4) Outlet shall include 15 amp GFI receptacles with independent fuse protection.
    - 5) Outlet shall be accessible from outside the unit.
    - 6) Outlet shall include a field installed "Wet in Use" cover.
  - c. Field-Installed Non-Powered convenience outlet.
    - 1) Outlet shall be powered from a separate 115/120v power source.
    - 2) A transformer shall not be included.

- 3) Outlet shall be field-installed and internally mounted with easily accessible 115-v female receptacle.
  - 4) Outlet shall include 20 amp GFI receptacles. This kit provides a flexible installation method which allows code compliance for height requirements of the GFCI outlet from the finished roof surface as well as the capability to relocate the outlet to a more convenient location.
  - 5) Outlet shall be accessible from outside the unit.
  - 6) Outlet shall include a field installed "Wet in Use" cover.
10. Thru-the-Base Connectors:
- a. Kits shall provide connectors to permit gas and electrical connections to be brought to the unit through the unit basepan.
  - b. Minimum of four connection locations per unit.
11. Supply Duct Cover (size 16 only):
- a. Required when field converting the factory standard vertical duct supply to horizontal duct supply configuration. One required per unit.
12. Propeller Power Exhaust:
- a. Power exhaust shall be used in conjunction with an integrated economizer.
  - b. Independent modules for vertical or horizontal return configurations shall be available.
  - c. Horizontal power exhaust shall be mounted in return ductwork.
  - d. Power exhaust shall be controlled by economizer controller operation. Exhaust fans shall be energized when dampers open past the 0 to 100% adjustable setpoint on the economizer control.
13. Roof Curbs (Vertical):
- a. Full perimeter roof curb with exhaust capability providing separate air streams for energy recovery from the exhaust air without supply air contamination.
  - b. Formed galvanized steel with wood nailer strip and shall be capable of supporting entire unit weight.
  - c. Permits installation and securing of ductwork to curb prior to mounting unit on the curb.
14. Outdoor Air Enthalpy Sensor:
- a. The outdoor air enthalpy sensor shall be used to provide single enthalpy control. When used in conjunction with a return air enthalpy sensor, the unit will provide differential enthalpy control. The sensor allows the unit to determine if outside air is suitable for free cooling.
15. Return Air Enthalpy Sensor:
- a. The return air enthalpy sensor shall be used in conjunction with an outdoor air enthalpy sensor to provide differential enthalpy control.
16. Indoor Air Quality (CO<sub>2</sub>) Sensor:
- a. Shall be able to provide demand ventilation indoor air quality (IAQ) control.
  - b. The IAQ sensor shall be available in duct mount, wall mount, or wall mount with LED display. The setpoint shall have adjustment capability.
17. Smoke detectors (factory-installed only):
- a. Shall be a four-wire controller and detector.
  - b. Shall be environmental compensated with differential sensing for reliable, stable, and drift-free sensitivity.
  - c. Shall use magnet-activated test/reset sensor switches.
  - d. Shall have tool-less connection terminal access.
  - e. Shall have a recessed momentary switch for testing and resetting the detector.
  - f. Controller shall include:
    - 1) One set of normally open alarm initiation contacts for connection to an initiating device circuit on a fire alarm control panel.
    - 2) Two Form-C auxiliary alarm relays for interface with rooftop unit or other equipment.
    - 3) One Form-C supervision (trouble) relay to control the operation of the Trouble LED on a remote test/reset station.
    - 4) Capable of direct connection to two individual detector modules.
    - 5) Can be wired to up to 14 other duct smoke detectors for multiple fan shutdown applications.
18. Winter Start Kit:
- a. Shall contain a bypass device around the low pressure switch.
  - b. Shall be required when mechanical cooling is required down to 25°F (-4°C).
  - c. Shall not be required to operate on an economizer when below an outdoor ambient of 40°F (4°C).
19. Time Guard:
- a. Shall prevent compressor short-cycling by providing a 5 minute delay (±2 minutes) before restarting a compressor after shutdown for any reason.
  - b. One device shall be required per compressor.
20. Disconnect Switch Bracket (size 16 only):
- a. Provides a pre-engineered and sized mounting bracket for applications requiring a unit mounted fused and non-fused disconnect of greater than 100 amps. Bracket assures that

no damage will occur to coils when mounting with screws and other fasteners.

21. Hinged Access Panels:
  - a. Shall provide easy access through integrated quarter turn latches.
  - b. Shall be on major panels of: filter, control box, fan motor, and compressor.
22. Condensate overflow switch:
  - a. This sensor and related controller monitors the condensate level in the drain pan and shuts down compression operation when overflow conditions occur. It includes:
    - 1) Indicator light — solid red (more than 10 seconds on water contact – compressors disabled), blinking red (sensor disconnected).
    - 2) 10 second delay to break — eliminates nuisance trips from splashing or waves in pan (sensor needs 10 seconds of constant water contact before tripping).
    - 3) Disables the compressors operation when condensate plug is detected, but still allows fans to run for Economizer.
23. 4 in. MERV-13 Return Air filters:
  - a. Factory option to upgrade standard unit filters to 4 in. MERV-13 filters. Filter media is securely fastened inside the filter frame on all four sides.
24. 4 in. filter rack kit:
  - a. The 4 in. filter rack accessory kit is designed to hold 4 in. MERV-8 or MERV-13 filters. Filters not included in kit.
25. 2 in. MERV-13 Return Air filters:
  - a. Accessory kit to field upgrade standard unit filters to 2 in. MERV-13 filters.
26. 2 in. MERV-8 Return Air filters:
  - a. Accessory kit to field upgrade standard unit filters to 2 in. MERV-8 filters.
27. Phase Monitor Control:
  - a. Shall monitor the sequence of three phase electrical system to provide a phase reversal protection.
  - b. Shall monitor the three phase voltage inputs to provide a phase loss protection for the three phase device.
  - c. Will work on either a Delta or Wye power connection.
28. Horn/Strobe Annunciator:
  - a. Provides an audible/visual signaling device for use with factory-installed option or field installed accessory smoke detectors.
    - 1) Requires installation of a field-supplied 24-v transformer suitable for 4.2 VA (AC) or 3.0 VA (DC) per horn/strobe accessory.
    - 2) Requires field-supplied electrical box, North American 1-gang box, 2 in. (51 mm) x 4 in. (102 mm).
    - 3) Shall have a clear colored lens.
29. Electric Heat:
  - a. Heating Section:
    - 1) Heater element open coil resistance wire, nickel-chrome alloy, 0.29 inches inside diameter, strung through ceramic insulators mounted on metal frame. Coil ends are staked and welded to terminal screw slots.
    - 2) Heater assemblies are provided with integral fusing for protection of internal heater circuits not exceeding 48 amps each. Auto reset thermo limit controls, magnetic heater contactors (24 v coil) and terminal block all mounted in electric heater control box (minimum 18 ga galvanized steel) attached to end of heater assembly.
30. UV-C ultraviolet lamp kit:
  - a. High-output, low temperature ultraviolet lamp accessory. It includes:
    - 1) 36 in. lamp, interlock switch, mounting brackets, necessary wires, wire ties, screws and labels to field install kit in unit return air plenum.
    - 2) Separate dedicated 115v power source required.
    - 3) UV-C kit can not be used on units with Humidi-MiZer system.
31. High Short Circuit Current Rating (SCCR) protection:
  - a. Factory-installed option provides high short circuit current protection to each compressor, plus all indoor and outdoor fan motors of 10 kA against high potential fault current situations. (Standard unit comes with 5 kA rating.)
  - b. This option is not available with factory installed Non-Fused Disconnect, Humidi-MiZer system, Low Ambient controls, Phase loss monitor/protection and 575 Volt models.





