

TruVu™ UC683T

Installation and Start-up Guide

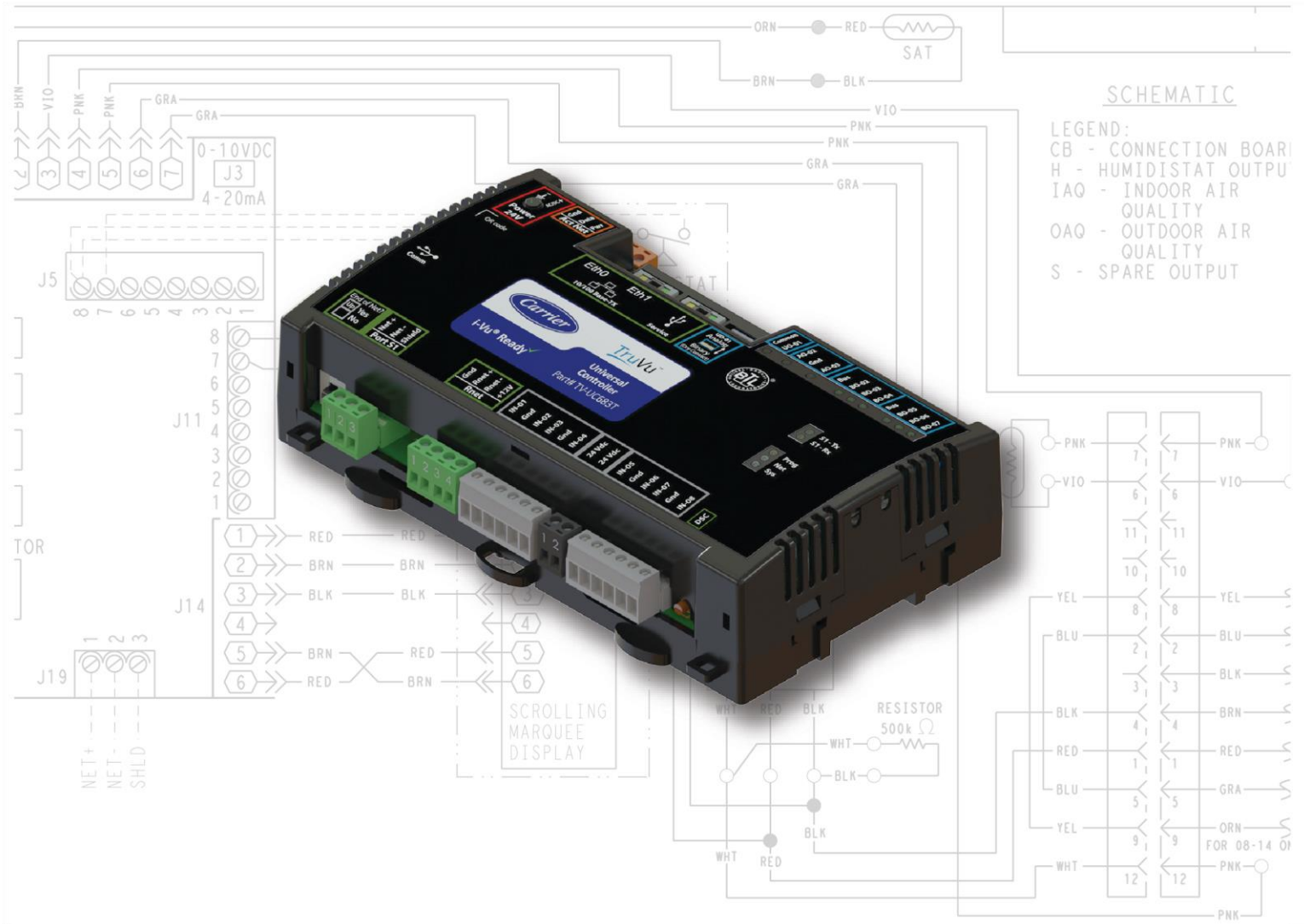



Verify that you have the most current version of this document from www.hvacpartners.com, the **Carrier Partner Community** website, or your local Carrier office.

Important changes are listed in **Document revision history** at the end of this document.

Carrier ©2022. All rights reserved.



Contents

What is the TV-UC683T?	1
Specifications	2
Zone sensors	6
Touchscreen devices	6
To mount the TV-UC683T	7
Wiring for power	8
To wire for power	8
Addressing the TV-UC683T through the Service port	9
To set the IP address.....	11
To set the Port S1 address and baud rate	12
Addressing a network of controllers using the controller setup Local Network tab	13
Method 1: To address when you know the serial numbers	13
Method 2: To address when you do not know the serial numbers	14
Wiring for communications	15
Wiring specifications	16
To connect the TV-UC683T to the Ethernet.....	16
To wire to a BACnet MS/TP network	17
To wire a third-party device	17
Wiring devices to the TV-UC683T's Rnet port	18
Wiring devices to the TV-UC683T's Act Net port	19
Wiring inputs and outputs	21
Inputs	21
Outputs	21
Wiring specifications	22
To wire inputs and outputs.....	23
To adjust input and output properties	27
Input values	28
Output values	29
Resolution values	30
Offset/Polarity values	30
Find and upload in the I-Vu® interface	31
Adjusting the TV-UC683T driver properties	32
Driver	32
Device	34
Notification Classes.....	34
Calendars	35
Common Alarms	36
Specific Events	37
Custom Translation Tables.....	37
BACnet Controller Properties	38
BACnet Firewall.....	38
Network Diagnostics - Statistics.....	39
Network Diagnostics - Packet Capture.....	40
Act Net Bus	41
Communication Status	43
Flow Calibration Archive	43
To set up Network Statistic trends.....	43
To set up the controller through the Service port	45
ModStat tab.....	45

Device tab	46
Ports tab.....	46
BACnet tab.....	47
Modbus tab.....	47
Security tab.....	47
Local Network tab.....	47
To communicate through the BACnet/Service port network.....	51
To communicate locally through the Rnet port.....	53
To set up a Local Access connection in the i-Vu® interface	54
Troubleshooting.....	55
LEDs	55
To configure custom Prog LED	57
To get a Module Status report	58
Troubleshooting inputs and outputs	58
To get a Device Log	59
To get the TV-UC683T's serial number	60
To replace the TV-UC683T's fuse.....	60
To revert to default settings	61
To take the TV-UC683T out of service	62
Compliance	63
FCC Compliance.....	63
CE and UKCA Compliance	63
Industry Canada Compliance.....	63
BACnet Compliance.....	63
Appendix - Module Status field descriptions	64
Document revision history	66



What is the TV-UC683T?

The TruVu™ Universal Controller (part# TV-UC683T):

- Runs control programs
- Supports BACnet/IP communications on the 10/100 Ethernet port as a single node in a daisy-chain configuration or as part of a network using a ring topology
- Supports DHCP IP addressing
- Has built-in network diagnostic capture functionality for troubleshooting
- Has network statistics that can be viewed numerically or as trend graphs
- Supports BACnet/MS/TP
- Supports Rnet devices
- Supports Act Net devices
- Works with the i-Vu® v7.0 or later system with the latest cumulative patch
- Works with Field Assistant v7.0 or later with the latest cumulative patch
- Can act as a:
 - Master or slave on a Modbus serial network
 - Server or client on a Modbus TCP/IP network
- Provides 8 universal inputs, 6 binary outputs, 2 analog outputs, and 1 universal output
- The universal output can be configured as binary, analog, or pulse-width modulated analog

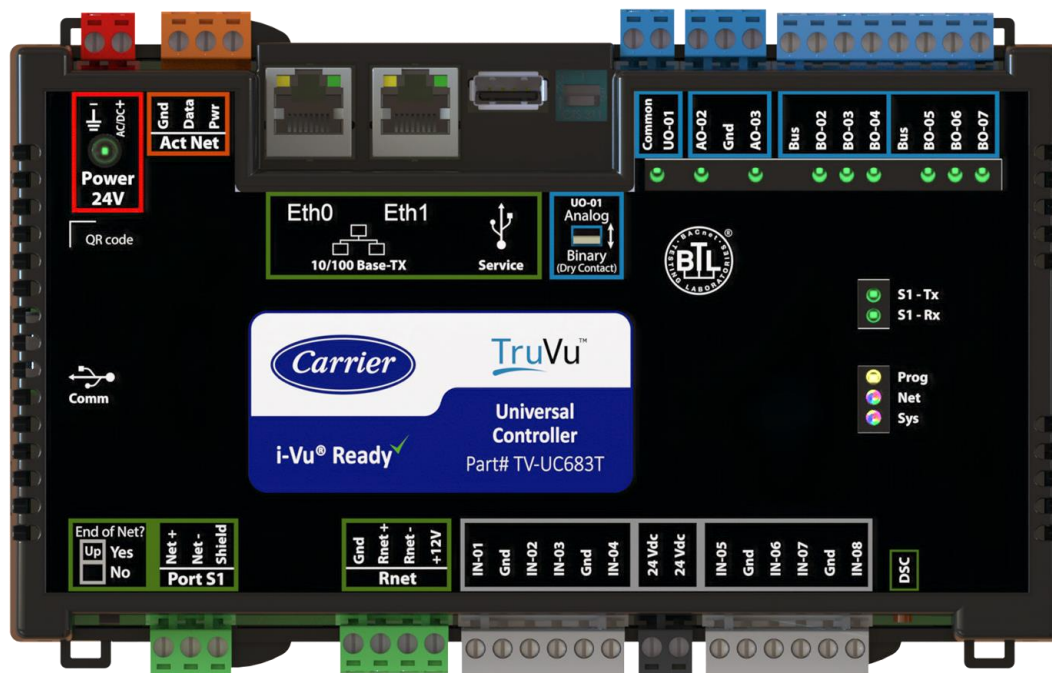

What is the TV-UC683T?

You can use the TV-UC683T's physical communication ports as follows:

Port	Port type	For this type of communication...	At...
Eth0 Eth1	10/100 Mbps Ethernet*	BACnet/IP, BACnet/Ethernet, and/or Modbus TCP/IP	10 or 100 Mbps
S1	High-speed EIA-485 port	BACnet/MSTP or Modbus Serial	9.6 to 115.2 kbps 9.6 to 115.2 kbps

* The Ethernet ports can run Modbus simultaneously with either BACnet/IP or BACnet/Ethernet.

The TV-UC683T also has the following ports:

- Rnet port for connecting ZS sensors, an Equipment Touch, an TruVu™ ET Display, and Wireless Adapter for wireless sensors
- Service USB port for connecting locally to controller setup pages, the TruVu™ ET Display, or the Carrier wireless service adapter
- Comm USB port for other communication options in the future
- Act Net port supports a combination of up to 5 Act Net addresses, as follows:
 - Address **1** is reserved for the Carrier actuator
 - Address **2** and **3** are reserved for the VAV Zone II Secondary Duct
 - Address **4** and **5** for i-Vu® Smart Valves

Specifications

Driver	drv_fwex_< version >.driverx
Maximum number of control programs*	10
Maximum number of BACnet objects*	12000
Third-party BACnet integration points	300
NOTE Must be on the BACnet/IP network	
Third-party Modbus integration points	50



* Depends on available memory.

Power	<p>24 Vac \pm15%, 50–60 Hz, 55 VA 24 Vdc \pm10%, 20 W</p> <p>NOTE The above power consumption is for the controller only. Adding devices to the Act Net bus increases total power consumed.</p>
Eth0, Eth1	<p>10/100 BaseT, full duplex, Ethernet ports for BACnet/IP and/or BACnet/Ethernet, or Modbus TCP/IP communication.</p> <p>Under normal operation, network traffic not destined for this controller is repeated to the other Ethernet port. When the controller is powered off, all traffic received on one port is mirrored to the other port.</p>
Port S1	<p>For communication with either of the following:</p> <ul style="list-style-type: none"> • A BACnet MS/TP network at 9.6 to 115.2 kbps • A Modbus serial network at 9.6 to 115.2 kbps <p>This port's End of Net? switch can be set to Yes to terminate the network segment.</p>
Rnet port	<ul style="list-style-type: none"> • Supports up to 15 wireless and/or ZS sensors, and one Equipment Touch or TruVu™ ET Display • Supplies 12 Vdc/260 mA power to the Rnet across its rated temperature range. <p>NOTE Ambient temperature and power source fluctuations exceeding the listed operating ranges may reduce the power supplied by the Rnet port.</p> <p>NOTE If the total power required by the sensors on the Rnet exceeds the power supplied by the Rnet port, use an external power source. The Wireless Adapter, Equipment Touch, or TruVu™ ET Display must be powered by an external power source. See the specifications in each device's Installation and Start-up Guide to determine the power required.</p>
Act Net port	<p>Supports a combination of up to 5 Act Net addresses, as follows:</p> <ul style="list-style-type: none"> • Address 1 is reserved for the Carrier actuator • Address 2 and 3 are reserved for the VAV Zone II Secondary Duct • Address 4 and 5 for i-Vu® Smart Valves <p>Maximum power available for Act Net devices:</p> <ul style="list-style-type: none"> • AC supply - 25 VA (1 A) • DC supply - 15W (0.625A) • Use an external transformer if your devices exceed the maximum power.
Service port	<p>USB 2.0 host port for setting up the controller and troubleshooting through a local connection to a computer, connecting to the TruVu™ ET Display, or the Carrier wireless service adapter.</p>
Comm port	<p>For future use.</p>
Aux 24V+ DC	<p>8 Terminals</p> <p>Supplies 24Vdc to external I/O devices, max 200mA total (when controller powered by AC) or max 500mA total (when controller powered by DC)</p>
Universal inputs	<p>8</p> <p>Inputs are configurable in the control program for 0–5 Vdc, 0–10 Vdc, thermistor, dry contact, or pulse counter.</p>
Input resolution	<p>12 bit A/D</p>

Input pulse frequency	10 pulses per second. Minimum pulse width (on or off time) required for each pulse is 50 msec.
24 Vdc terminal	Supplies 24 Vdc to external I/O devices, max 100 mA
Universal output	This output can be set by a DIP switch as an Analog or Binary output. <ul style="list-style-type: none"> In Analog mode, the output can be used for 0-10 Vdc or a 12 Vdc pulse width modulated (PWM) control signal at a frequency of 80 Hz. In Binary mode, the output has a built-in relay and can be used to switch external devices or relays up to 3.75A, 30 Vac/Vdc.
Binary outputs	2 banks of bussed outputs, 3 N.O. binary outputs per bank. Each relay contact rated at 3.75 A max. @ 30 Vac/Vdc. Each bank is limited to Class 2 requirements of 100 VA / 4.2 A. Configured normally open. See <i>Output values</i> (page 29).
Output resolution	12 bit D/A
Controller microprocessor	32-bit ARM Cortex-A8, 600MHz, processor with multi-level cache memory
Memory	4 GBs eMMC Flash memory and 256 MB DDR3 DRAM (2 MB available). User data is archived to non-volatile Flash memory when parameters are changed, every 90 seconds, and when the firmware is deliberately restarted. NOTE When you change a parameter, you must wait 30 seconds before turning the power off, in order for the change to be saved.
Real-time clock	Real-time clock keeps track of time in the event of a power failure for up to 3 days.
Protection	A single fast acting, 5mm x 20mm glass fuse for power The power and network ports comply with the EMC requirements EN50491-5-2.  CAUTION To protect against large electrical surges on serial EIA-485 networks, place a PROT485 at each place wire enters or exits the building.
LED status indicators	See <i>LEDs</i> (page 55) for details. <ul style="list-style-type: none"> Tricolor Net LED to show network status Tricolor Sys LED to show controller status A Tx (Transmit) and Rx (Receive) LED for Port S1 Tx (Transmit) and Rx (Receive) activity LED and yellow link status LED for the following ports: <ul style="list-style-type: none"> Ethernet port Eth0 Ethernet port Eth1 Output LEDs indicate status of each output. Prog LED is customizable.
Environmental operating range	-40 to 158 °F (-40 to 70 °C), 10-95% relative humidity, non-condensing NOTES <ul style="list-style-type: none"> The TV-UC683T is suitable for installation inside or outside the building envelope. Install in a UL Listed enclosure only. Do not change the position of the End of Net switch at temperatures below -22 °F (-30C) to ensure proper operation and electrical connectivity.
Physical	Fire-retardant plastic ABS, UL94-5VA

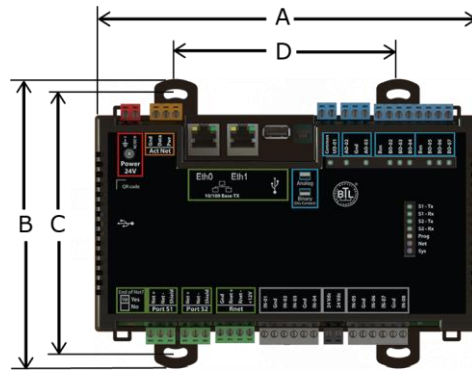
Terminal blocks and connectors	Screw-type terminal blocks. 0.2 in (5.08 mm) pitch connectors
Mounting	35mm DIN rail mounting or screw mounting



Overall dimensions	A: 7.78 in. (19.77 cm) B: 5.88 in. (14.94 cm) Depth: 2.00 in. (5.09 cm)
Screw mounting dimensions	C: 5.3 in (13.45 cm) D: 4.50 in. (11.43 cm)
Weight	1.2 lbs (0.54 kg)
BACnet support	Conforms to the BACnet Advanced Application Controller (B-AAC) and B-BBMD Standard Device Profiles as defined in ANSI/ASHRAE Standard 135-2012 (BACnet) Annex L, Protocol Revision 14
Compliance	United States of America: FCC CFR, Part 15, Class B Canada: Industry Canada Compliant, ICES-003, Class A cUL Listed UL 916, PAZX7, Energy Management Equipment Europe:  Mark, UK:  EN50491-5-2:2009; Part 5-2: EMC requirements for HBES/BACS used in residential, commercial and light industry environment RoHS Compliant: 2015/863/EU REACH Compliant

Zone sensors

You can wire ZS sensors and/or a Wireless Adapter that communicates with wireless sensors to the TV-UC683T's Rnet port. You can have up to 15 ZS and/or wireless sensors.

NOTES

- A control program can use no more than 5 ZS sensors, so you must use multiple control programs if your Rnet network has more than 5 sensors.
- ZS and wireless sensors can share the Rnet with an Equipment Touch or TruVu™ ET Display.



CAUTION Rnet power

The Rnet port provides 12 Vdc at 260 mA maximum that can be used to power zone sensors. When determining which devices to put on the Rnet, verify that the total current draw of the sensors does not exceed the controller's Rnet power. See the sensor's *Installation and Start-up Guide* to determine the power required.

Touchscreen devices

You can connect the TV-UC683T to the touchscreen devices using the Rnet port or the USB Service port.

Rnet port

You can wire an Equipment Touch or TruVu™ ET Display to the TV-UC683T's Rnet port to view or change the controller's property values, schedule equipment, view trends and alarms, and more, without having to access the system's server. The Rnet port can have one Equipment Touch or TruVu™ ET Display, plus ZS sensors and/or a Wireless Adapter that communicates with wireless sensors.

NOTE These touchscreen devices are not powered by the Rnet port.

- The TruVu™ ET Display requires a 24 Vdc external power source.
- The Equipment Touch requires a 24 Vac external power source.

USB port

You can connect the TruVu™ ET Display to the TV-UC683T's USB Service port to view or change the controller's property values, schedule equipment, view trends and alarms, and more, without having to access the system's server.

NOTES

- These touchscreen devices are not powered by the USB port.
- The TruVu™ ET Display requires a 24 Vdc external power source.



CAUTION A touchscreen device can share a power supply with the Carrier controller if:

- The power source shared by the controller and Equipment Touch is AC power.
- The power source shared by the controller and TruVu™ ET Display is DC power.
- You maintain the same polarity.
- You use the power source only for Carrier controllers.

To mount the TV-UC683T

The TV-UC683T can be mounted on a DIN rail or screwed to a surface.

DIN rail mount

- 1 In the trough on the back of the controller, hook the edge of the DIN rail under the controller's two mounting flanges.
- 2 Push the controller toward the DIN rail until you hear it click and the spring-loaded latch secures the controller to the DIN rail.

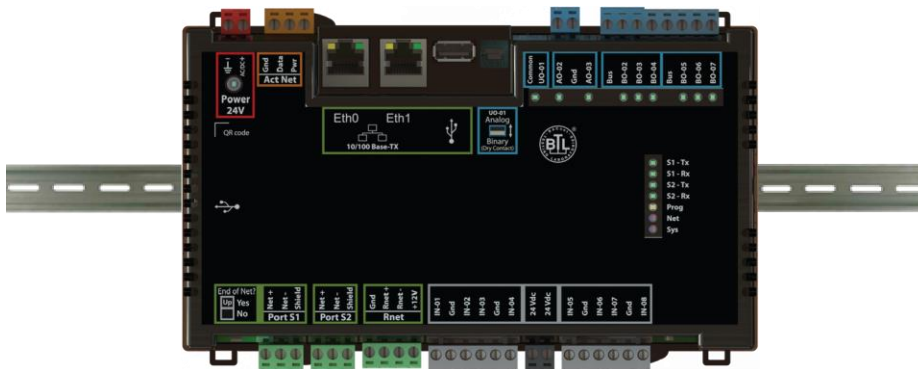

Screw Mount

Leave about 2 in. (5 cm) on each side of the controller for wiring.

Pull the mounting tabs until they click in place. Insert #6 screws through them. Use no more than 12 in lbs. torque to secure plastic tab to mounting surface. Use flat washers to prevent the screw head from deforming the plastic.

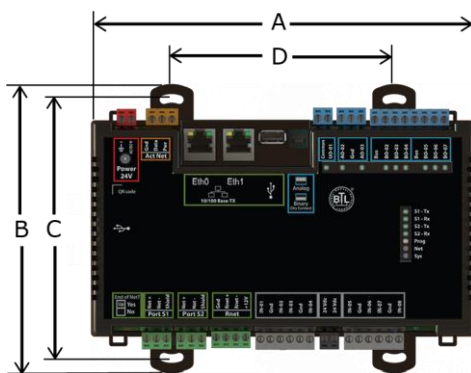

- A: 7.78 in. (19.77 cm)
- B: 5.88 in. (14.94 cm)
- C: 5.3 in. (13.45 cm)
- D: 4.50 in. (11.43 cm)
- Depth: 2.00 in (5.08 cm)

Wiring for power



WARNING Do not apply line voltage (mains voltage) to the controller's ports and terminals.



CAUTIONS

- The TV-UC683T is powered by a Class 2 power source. Take appropriate isolation measures when mounting it in a control panel where non-Class 2 circuits are present.
- Carrier controllers can share a power supply as long as you:
 - Maintain the same polarity.
 - Use the power supply only for Carrier controllers.

To wire for power

- 1 Remove power from the power supply.
- 2 Pull the red screw terminal connector from the controller's power terminals labeled **24V**.
- 3 Connect the power supply's wires to the red screw terminal connector.
- 4 Connect an 18 AWG or larger wire from the power supply's negative (-) terminal to earth ground. This wire must not exceed 12 in. (30.5 cm).
- 5 Apply power to the power supply.
- 6 Measure the voltage at the red screw terminal connector to verify that the voltage is within the operating range of 20.4 to 28.8 Vac or 21.6 to 28.8 Vdc.
- 7 To verify the polarity of the wiring, measure the voltage from the negative terminal of the red screw terminal connector to a nearby ground. The reading should be 0V.
- 8 Insert the red screw terminal connector into the controller's power terminals.
- 9 Verify that the  LED on top of the controller is on.

Addressing the TV-UC683T through the Service port

The TV-UC683T is addressed using the controller setup pages. The **Local Network** tab allows you to discover all TruVu™ devices on a single network and configure them from that page. See *Addressing a network of controllers using the controller setup Local Network tab* (page 13) and the *Local Network* (page 47) tab.

You can connect the TV-UC683T to a computer using either the Carrier wireless service adapter or a USB cable.

NOTE You cannot access the Service port by plugging an Ethernet cable into Eth0 or Eth1.



CAUTION The USB local access cable provides a common ground connection between the computer and the controller it connects to. Damage to the controller and possibly the computer's USB port will occur if the controller's input power polarity was not maintained and was also not properly grounded (floating). If you are not sure of the wiring polarity and that the controller was properly grounded, use a USB isolator between the computer and the controller.

To connect the TV-UC683T to a computer using the Carrier wireless service adapter.

- 1 Insert the Carrier wireless service adapter (part# USB-W) into the controller's USB Service Port to communicate with a Wi-Fi-compatible computer.



CAUTION If the Eth1 port is in use, connect a USB Type-A Male to Female extension cable to the USB Service Port and the Carrier wireless service adapter.

- 2 Open your computer's wireless network display to view your available wireless networks.

NOTE TV-UC683T only supports the 5 GHz band and not the 2.4 GHz band.

- 3 Connect to the wireless network using the network SSID and password that are printed on the Carrier wireless service adapter.
- 4 Open a web browser on the computer and navigate to <http://local.access> or <http://169.254.1.1> to see the controller setup pages.

To connect the TV-UC683T to the computer using a USB cable.

- 1 Connect a USB Type-A Male to Male USB cable from a computer to the controller's USB Service Port, as shown below.

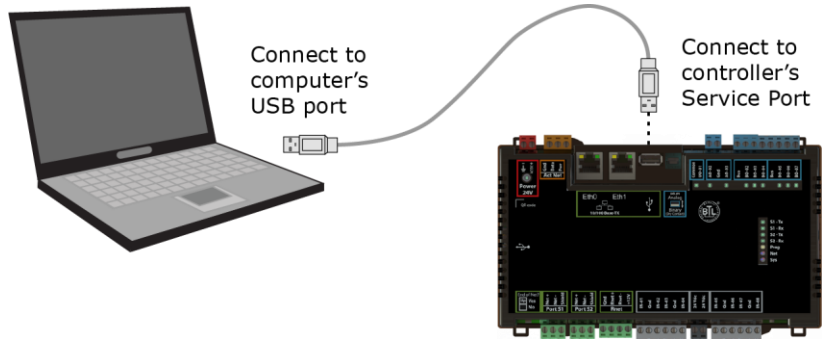

- 2 A new Ethernet connection will appear on your computer.
- 3 If your computer uses a static IP address, use the following settings for the new connection:
 - o Address: 169.254.1.x, where x is 2 to 7
 - o Subnet Mask: 255.255.255.248
 - o Default Gateway: 169.254.1.1If it uses a DHCP address, leave the address as it is.
- 4 Open a web browser on the computer
- 5 Navigate to <http://local.access> or <http://169.254.1.1> to see the controller setup pages.

See *To set up the controller through the Service Port* (page 45) for detailed information.

To set the IP address

You must define the TV-UC683T's IP addressing (IP address, subnet mask, and default gateway) on the controller setup **Ports** tab so that the controller can communicate with the i-Vu Server on the IP network.

Use one of the IP addressing schemes described below with the associated instructions that follow.

Use a...	If...
DHCP IP Address generated by a DHCP server	The IP network uses a DHCP server for IP addressing
Custom Static IP Address from your network administrator	You do not use a DHCP server and the answer to any of the following questions is yes. Will the i-Vu® system: <ul style="list-style-type: none"> • Share a facility's existing IP data network? • Be connected to the Internet? • Have at least one device located on the other side of an IP router? • Be connected to any third-party IP devices?

NOTE Carefully plan your addressing scheme to avoid duplicating addresses. If third-party devices are integrated into the system, make sure your addresses do not conflict with their addresses.

To set a DHCP IP address

- 1 On the controller setup **Modstat** tab, find the controller's **Ethernet MAC address** and write it down.
- 2 On the **Ports** tab under **IP Port**, select **DHCP**.
- 3 Click **Save**.
- 4 Write down the **IP Address**.
- 5 Give the DHCP network administrator the IP address and Ethernet MAC address and ask him to reserve that IP address for the controller so that it always receives the same IP address from the DHCP server.

To set a custom static IP address

- 1 Obtain the IP address, subnet mask, and default gateway address for the controller from the facility network administrator.
- 2 On the controller setup **Ports** tab under **IP Port**, select **Custom Static**.
- 3 Enter the **IP Address**, **Subnet Mask**, and **Default Gateway** addresses that the network administrator gave you.
- 4 Click **Save**.

To set the Port S1 address and baud rate

The address should be in one of the following ranges based on the port's use:

- For MS/TP Master, the range is 0 to 127.
- For MS/TP Slave, the range is 128 to 255.
- For Modbus, the range is 1 to 247.

You set this address on the TV-UC683T's controller setup pages.

The TV-UC683T can automatically receive or establish the baud rate on an MS/TP or Modbus serial network. When you configure a device on the network for autobaud and then power it up, the device detects the incoming baud rate on the network and sets its baud to match.

Autobaud does not work unless there is a device on the network, whether Carrier or third party, that has the baud rate already set. You can manually set the baud rate on more than one device, as long as the rate is the same for every device.

NOTE The discovered autobaud rate stays intact during power cycles.

MS/TP

For MS/TP on Port S1, set up autobaud or the baud rate

- On the controller setup pages > **BACnet** tab > **Port S1**
- In the i-Vu® interface, on the navigation tree, right-click your TV-UC683T > select **Driver Properties** > **BACnet Controller Properties** > **MS/TP Configuration** on Port S1. See *BACnet Controller Properties* (page 38).

NOTES

- If not using autobaud, enter the identical baud rate for all devices on the same MS/TP network segment.
- If using autobaud, we recommend you set the baud rate manually on the router for the MS/TP network segment.

Modbus

For Modbus Serial on Ports S1, set up autobaud or the baud rate

- On the controller setup pages > **Modbus** tab > **Modbus RS-485** > **Port Configuration**
- In the i-Vu® interface, on the navigation tree, right-click your TV-UC683T > select **Driver Properties** > **Communication Status** > **Modbus Serial**.

NOTE For details on setting up your network, see the *Modbus Integration Guide*.

NOTE If you set **Autobaud** or make other changes in the controller setup pages, you must upload the changes to the system database the first time you access the controller in the i-Vu® interface. This preserves those settings when you download memory or parameters to the controller.

Addressing a network of controllers using the controller setup Local Network tab

You can use the controller setup **Local Network** tab to discover Carrier TruVu™ devices on a single network. You can configure them and assign addresses to each one using one of the methods described below.

NOTE For this discovery tool to work, the controllers must reside on the same subnet and be downloaded with drv_fwex_107-xx-xxxx or later.

Method 1: To address when you know the serial numbers

- 1 Connect one TruVu™ device on the IP network to the Service port. For details, see *Addressing the TV-UC683T through the Service port* (page 9).

NOTE This device is referred to as the "connected controller".

- 2 Browse to the Service Port address (http://local.access or http://169.254.1.1).
- 3 On the **Ports** tab, set the device's **IP Address**, **Subnet Mask**, and **Default Gateway**.
- 4 On the controller setup **Local Network** tab, verify that the device's address information is displayed at the top of the page.
- 5 On the **Local Network** tab, click the **Clear All** button to erase the **Local Devices** table if there is information in it.
- 6 Click **Discover**. The table finds and lists the first 256 unconfigured devices on the same subnet. The table is sorted by serial number.

NOTE A maximum of 256 TruVu™ controllers can be discovered and displayed in the **Local Devices** table. If you have more than 256 controllers on your network, configure some or all the controllers in the table and click **Clear**. Check **Only Unconfigured** and click **Discover** again. A count appears above the table to report the total number of controllers and the discovered number.

- 7 To configure devices:
 - One at a time - Enter the IP **Address** and **Location** or name (optional) of each device you wish to configure. When you enter the IP address, that device inherits the original device's subnet mask and default gateway.
 - Multiple devices simultaneously - **Select** the devices you want to address, enter the starting IP address in the field under the **Address** heading, and then click **Assign**. The selected devices are automatically assigned sequential IP addresses.

NOTE To change the IP Address, the device's **Mode** must be **Custom Static**.

For more details about discovering and configuring your devices, see **Local Network tab** (page 47).

Method 2: To address when you do not know the serial numbers

You will need physical access to each device so that you can press the DSC button on the bottom right of the TV-UC683T. This allows you to identify the device on the controller setup **Local Network** page.



- 1 Connect to the Service Port of one TruVu™ IP device on the network. For details, see *Addressing the TV-UC683T through the Service port* (page 9).
- 2 Browse to the Service Port address (<http://local.access> or <http://169.254.1.1>).
- 3 On the **Ports** tab, set the device's **IP Address**, **Subnet Mask**, and **Default Gateway**.
NOTES The other devices that you configure inherit this device's subnet mask and default gateway.
- 4 On the **Local Network** tab, click the **Clear All** button to erase any pre-existing data in the **Local Devices** table.
- 5 On the controller you want to address, press the DSC button on the bottom right. When pressed, a row appears in the **Local Devices** table on the **Local Network** tab. The row has a blue dot to indicate which controller has just had the button pressed.
- 6 In the row for the identified controller, enter the **Address** and **Location** (optional).
- 7 Repeat steps 3 and 4 for each controller that you want to address.
- 8 For more details about discovering and configuring your devices, see **Local Network tab** (page 47).

NOTE To physically identify a device that is displayed on the **Local Devices** table, you can click the **Blink** button, which causes that device's **Net** and **Sys** LEDs to flash light blue for 10 seconds.

The following are two possible methods you could use to identify and assign a network of controllers' addresses after following steps 1 - 4 above.

- Two technicians can work together if they are communicating throughout the process. The first technician physically travels around the building to each controller, tells his co-worker exactly where he is, and then presses the DSC button. The second technician, who is sitting at a computer connected to the controller, watches for the blue dot to show up on the **Local Devices** table on the **Local Network** tab, where he can enter the appropriate addressing and identifying information.
- One technician alone can address the controllers on a mobile device showing the Local Network page by plugging the Carrier wireless service adapter into a controller's Service Port. Then, with the computer, move to each controller within 100 ft. of the adapter. Pressing the DSC button on the controller displays a blue dot in the table where the addressing information can be entered.

Wiring for communications

The TV-UC683T communicates on the following ports.

Port	Protocol	Port type(s)	Speed(s)
Eth0 Eth1	BACnet/IP BACnet/Ethernet Modbus TCP/IP	Ethernet	10 or 100 Mbps
Port S1 ¹	BACnet/MSTP Modbus Serial	RS485	9.6 to 115.2 kbps
Service Port ²	USB 2.0	USB	
Comm Port (future use)	USB 2.0	USB	
Rnet Port	See <i>Wiring devices to the TV-UC683T's Rnet port</i> (page 18).		
Act Net Port	See <i>Wiring devices to the TV-UC683T's Act Net port</i> (page 19).		

¹ Default for MS/TP is 76.8 kbps.
Default for Modbus is 38.4 kbps.

² See *To set up the controller through the Service port* (page 45).

Wiring specifications

For...	Use...	Maximum Length
Ethernet - not daisy chained	Cat5e or higher Ethernet cable	328 feet (100 meters)
Ethernet - a daisy chain configuration	Cat5e or higher Ethernet cable	164 feet (50 meters)
MS/TP *	22 AWG, low-capacitance, twisted, stranded, shielded copper wire	2000 feet (610 meters)

* See the *MS/TP Networking and Wiring Technical Instructions*.

WARNINGS

- Do not apply line voltage (mains voltage) to the controller's ports and terminals.
- Do not exceed the minimum bend radius of the Cat5e or Cat6e Ethernet cable. Refer to Ethernet cable manufacturer specifications for minimum bend radius.

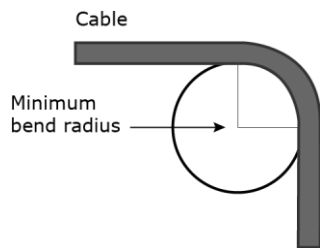

To connect the TV-UC683T to the Ethernet

Connect an Ethernet cable from the building BAS system or another TV-UC683T controller to the Eth0 Ethernet port. If necessary, connect another Ethernet cable from the Eth1 port to the next TV-UC683T controller in a daisy chain.

The TV-UC683T has a fail-safe Ethernet relay that bypasses a daisy chained controller in the event of an internal disruption, such as a power loss. When a failure occurs and the switch is bypassing a controller, the network connection on both sides of the controller are electrically connected, which continues the signal and passes it to the next controller.

NOTE If your system has controllers on different IP subnets separated by an IP router, you must configure one controller on each subnet as a BACnet Broadcast Management Device (BBMD). Do not configure more than one BBMD per subnet as this may cause circular routes. See "Setting up BACnet Broadcast Management Devices (BBMDs)" in SiteBuilder or i-Vu® Help.

To wire to a BACnet MS/TP network

An MS/TP network can be wired to **Port S1**.

- 1 Turn **off** the TV-UC683T's power.
- 2 Check the communications wiring for shorts and grounds.
- 3 Connect the communications wiring to **Port S1**'s screw terminals labeled **Net +**, **Net -**, and **Shield**.

NOTE Use the same polarity throughout the network segment.

- 4 Set **Port S1** to **MS/TP** on the controller setup pages > **BACnet** tab > **Port S1**.
- 5 If the TV-UC683T is at either end of a network segment, set the port's **End of Net?** switch to **Yes**.

NOTE The controller's **End of Net** switch applies network termination and bias. If the controller is at the end of a network segment that includes a DIAG485 that has its **Bias** jumper in the ON position, set the **End of Net?** switch to **No** and connect a 120 ohm termination resistor to the **Net+** and **Net-** terminals. See *DIAG485 Technical Instructions* for more information.

- 6 Turn on the controller's power.

To wire a third-party device

BACnet: You can wire a third-party BACnet device to the TV-UC683T's **Eth0**, **Eth1** port or **Port S1**. See the *BACnet Integration Guide* for the TV-UC683T.

Modbus: You can wire a third-party Modbus master or slave device to **Port S1**. See *Modbus Integration Guide* for the TV-UC683T.

Wiring devices to the TV-UC683T's Rnet port

You can wire the following devices to the TV-UC683T's Rnet port in a daisy-chain configuration:

- ZS sensors
- Wireless Adapter that communicates with wireless sensors
- Equipment Touch
- TruVu™ ET Display

See the device's *Installation and Start-up* Guide for complete wiring instructions.

NOTES

- ZS sensors, a Wireless Adapter, and an Equipment Touch can share the same Rnet.
- The Rnet communicates at a rate of 115.2 kbps.

Wiring devices to the TV-UC683T's Act Net port

Supports a combination of up to 5 Act Net addresses, as follows:

- Address **1** is reserved for the Carrier actuator
- Address **2** and **3** are reserved for the VAV Zone II Secondary Duct
- Address **4** and **5** for i-Vu® Smart Valves

Maximum power available for Act Net devices:

- AC supply - 25 VA (1 A)
- DC supply - 15W (0.625A)
- Use an external transformer if your devices exceed the maximum power.



CAUTIONS

- If the power source for the Act Net devices require a connection to earth ground, you must place it in the same control panel as the TV-UC683T controller, so that it shares a common earth ground reference, thereby reducing the potential for ground loops.
- A remote Act Net power source, installed near the Act Net devices, should be floating (no local connection to earth ground).

The TV-UC683T provides an orange, three-pin removable screw terminal connector for the Act Net port.

Be careful to wire the Act Net port terminals on the controller to the matching terminal on the supported device. They may not be in the same order. See example below.

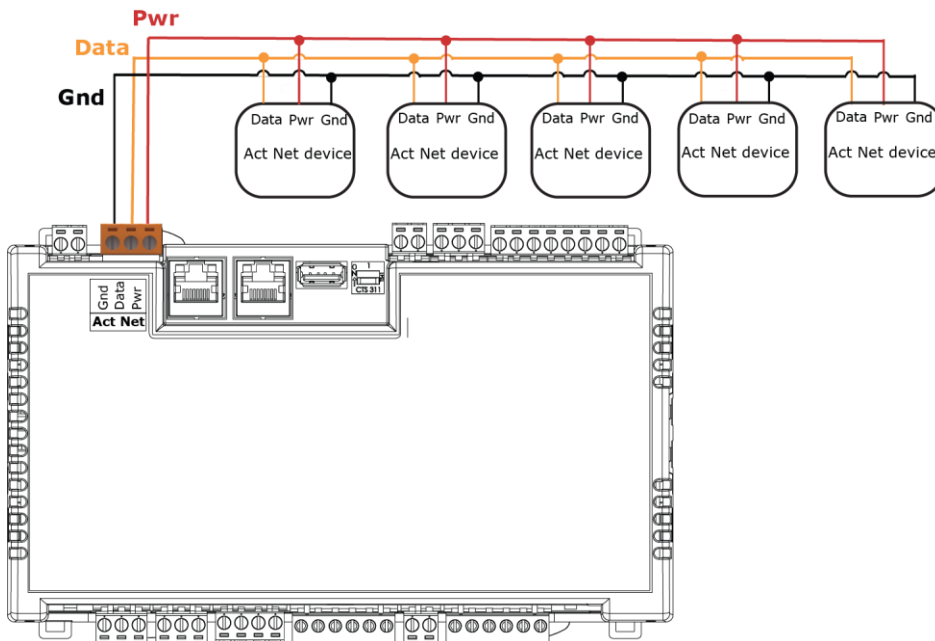

Wiring devices to the TV-UC683T's Act Net port

The TV-UC683T supports Act Net communication to the Act Net devices on a bus with a maximum length of 300 feet (91.44 meters). The bus should be wired with copper conductors of an appropriate size (18 AWG or larger) to compensate for voltage drop and ensure that bus voltage does not drop below 19.2 Vac or 21.6 Vdc.

Wiring inputs and outputs

Inputs

The TV-UC683T has inputs that accept the following signal types.

Signal Type	Description
Thermistor ¹	Precon Type 2 (10kOhm at 77 °F) Input voltages should be from 0.2 Vdc to 4.0 Vdc for thermistors
Dry contact	The maximum current when the contact is closed is 0.5 mA. The input voltage should be 4.1 V when the contact is open. Maximum closed contact resistance is 1kOhms.
0–5 Vdc 0–10 Vdc	The input impedance of the TV-UC683T is approximately 120 kOhm when configured as a voltage input.
Pulse counter ²	Pulse counting up to 10 pulses per second. Minimum pulse width (on or off time) required for each pulse is 50 msec.

¹ To use a thermistor not listed above, you can set up a *custom translation table* (page 37) for your sensor in the controller's driver.

² The TV-UC683T can perform pulse counting for Dry Contact or Binary Input if you assign the input to a Pulse to Analog Input microblock. See To adjust input and output properties.

Outputs

Analog outputs

Analog outputs can be used for 0-10 Vdc devices. Resistance to the ground must be 500 Ohms minimum.

NOTE The device must share the same ground as the controller.

Binary outputs

There are 2 banks of relays. Each bank contains 3 built-in relays with dry contacts that share a common bus input. An external voltage source must be wired to the common Bus connection for each bank of relays.

Each relay can be used to switch the voltage provided on its associated bus terminal to an external device or relay. Each relay can switch up to 3.75 A, 30 Vac/Vdc. The total power and current that can be switched by a bank of 3 relays cannot exceed the Class 2 limits of 100 VA or 4.2 A.

Universal output

The TV-UC683T's universal output can be set as analog or binary using the Analog/Binary DIP switch located to the left of the output terminals.

When the DIP switch is in the Analog position, the universal output can be used for pulse-width modulated (PWM) control of devices, such as electrically commutated motors. When used in pulse-width mode, the output voltage is 12 Vdc and the frequency is locked at 80 Hz. Use a BAO microblock to enable this.

NOTE The PWM output signal is intended to directly control the speed of an ECM-type fan, eliminating the need for an external converter board.



WARNING Do not apply voltage to the universal output if the DIP switch is set to Analog.

Wiring specifications

Input wiring

Input	Maximum length	Minimum gauge	Shielding
Thermistor Dry contact	1000 feet (305 meters)	22 AWG	Shielded
0–5 Vdc 0–10 Vdc	1000 feet (305 meters)	26 AWG	Shielded
Pulse counter TLO	1000 feet (305 meters)	22 AWG	Shielded

Output wiring

To size output wiring, consider the following:

- Total loop distance from the controller to the controlled device
NOTE Include the total distance of actual wire. For 2-conductor wires, this is twice the cable length.
- Acceptable voltage drop in the wire from the controller to the controlled device
- Resistance (Ohms) of the chosen wire gauge
- Maximum current (Amps) the controlled device requires to operate

To wire inputs and outputs

WARNING Do not apply line voltage (mains voltage) to the controller's ports and terminals.

The Gnd terminal is shared by the inputs/outputs to the right and left of it.

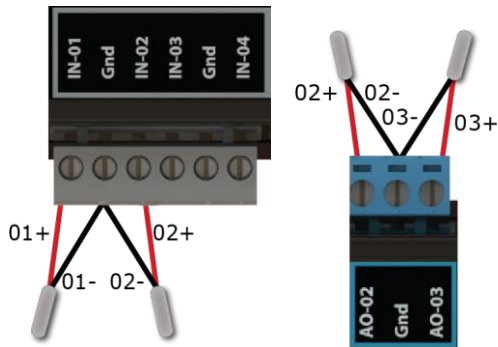

The TV-UC683T has connections for two separate busses.

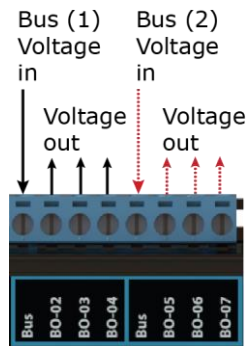

- 1 Verify that the TV-UC683T's power and communications connections work properly.
- 2 Turn **off** the TV-UC683T's power.

- 3 Connect the input wiring to the screw terminals on the TV-UC683T.

NOTE Connect the shield wire to the - terminal with the ground wire. Do not connect the shield wire at the other end of the cable as this will cause a ground loop error.

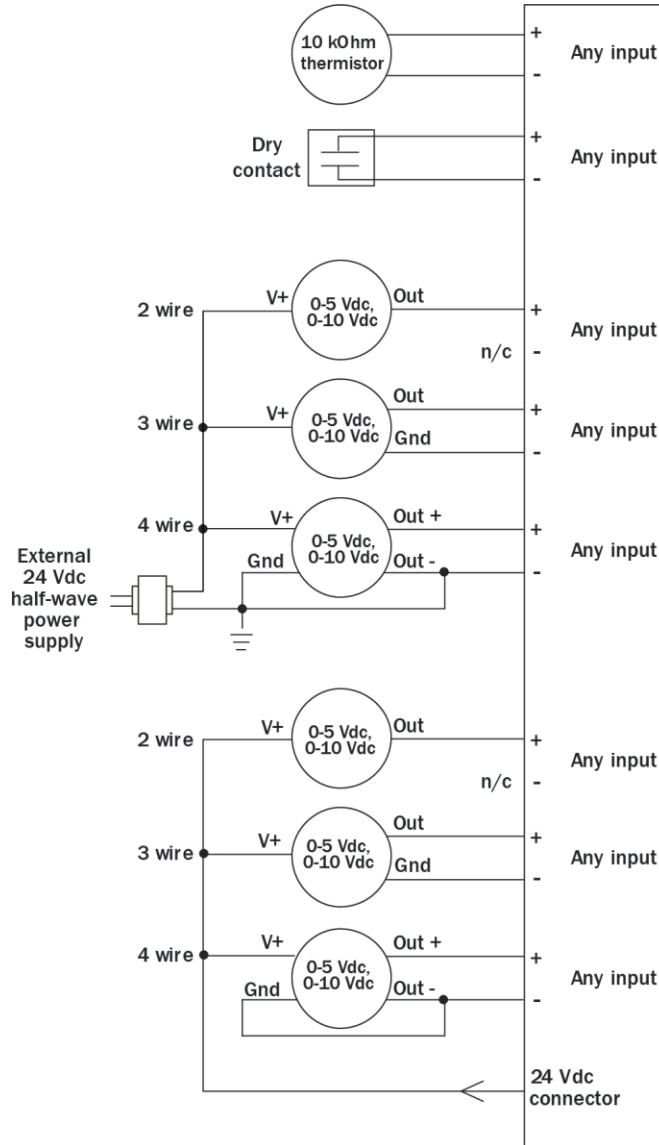

- 4 If you are using the UO, set the universal output's DIP switch to Binary or Analog for the type of device wired to the output.

⚠ WARNINGS

- The universal output is set to Binary in the factory. To avoid damage to the controller, use a voltmeter to verify there is no voltage on the UO-01 (+) and Common (-) terminals before setting the DIP switch to Analog.
- Do not apply voltage to the universal output if the DIP switch is set to Analog.

- 5 Connect binary and analog output wiring to the screw terminals on the TV-UC683T and to the controlled device.
- 6 Connect the ground wire to the AO outputs' terminals.

Analog outputs

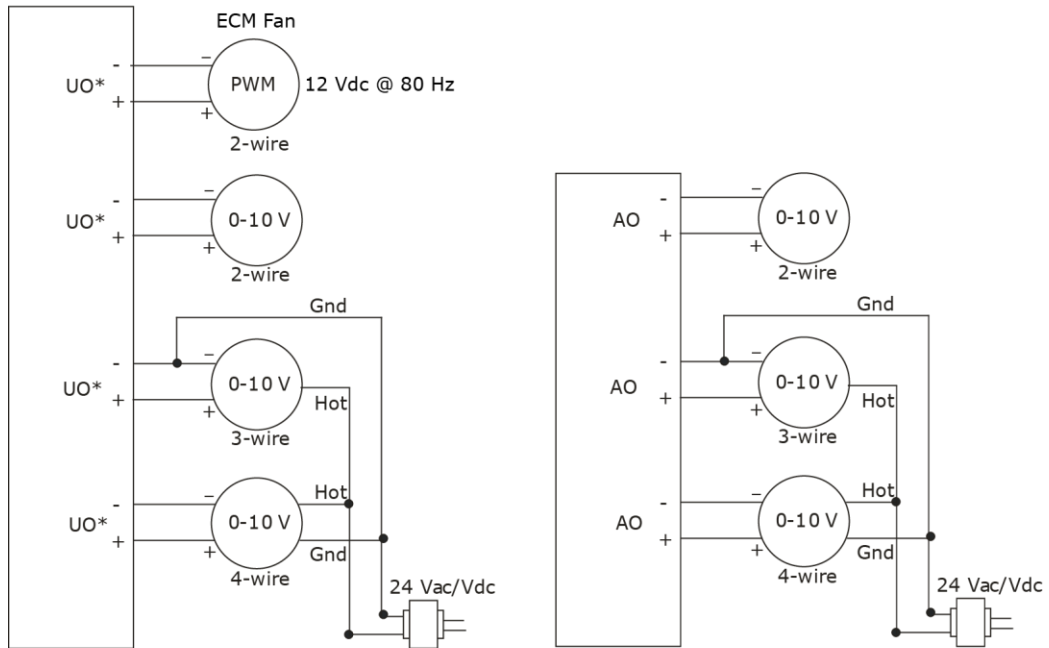

*Applicable when UO-01 is configured as an analog output.

Binary outputs

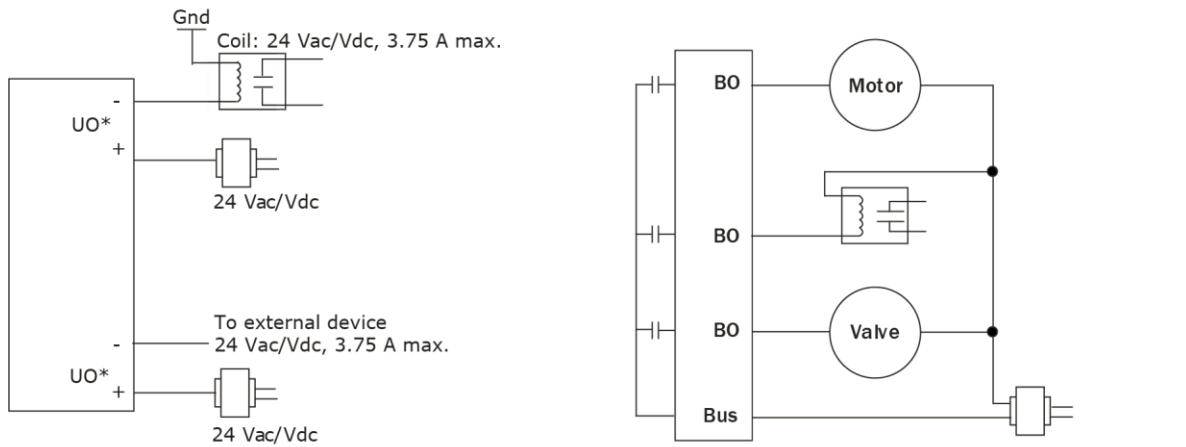

*Applicable when UO-01 is configured as a binary output.

7 Turn **on** the TV-UC683T's power.

See *Troubleshooting inputs and outputs* (page 58).

NOTE You can install connector covers (sold separately, part #PLM-KIT) by snapping them over the terminal block sections on the top and bottom of the controller.

To adjust input and output properties

An input or output must be assigned to its corresponding point in the control program. This is typically done when the control program is created, but you can adjust the settings at the time of installation in the i-Vu® interface.

- 1 In the i-Vu® navigation tree, select the equipment controlled by the TV-UC683T.
- 2 On the **Properties** page, select the **I/O Points** tab.
- 3 In each point's **Num** field, type the number of the controller's corresponding input or output. For example, if you use U01 on the TV-UC683T for the point **Pump S/S**, type 1 in the **Num** field for **Pump S/S**.

NOTES

- **Exp** (expander number) is **00** for the inputs and outputs located on the TV-UC683T.
 - Do not assign the same output number to more than one point.
- 4 Enter the appropriate values for each input and output in the remaining columns. See *Input values*, *Output values*, *Resolution values* and *Offset/Polarity values* below.
 - 5 If you have not performed the initial download to the attached controller, you must download now to verify inputs and outputs.
 - 6 To verify each input's operation, force each sensor to a known value, then compare it to the **Value** shown on the **Properties** page on the **I/O Points** tab.
 - 7 To verify each output's operation, lock each output to a known condition on the **I/O Points** tab, then verify that the equipment operates correctly.

See *Troubleshooting inputs and outputs* (page 58).

To adjust input and output properties

Input values

Input	I/O Type	Sensor/Actuator Type	Min/Max
Analog (BAI)			
0-5 Vdc	0–5 Volt	Linear Full Range	Engineering values associated with 0 Vdc (Min) and 5 Vdc (Max) ¹
		No Translation	N/A. The input microblock's value will be the raw voltage of the input.
0-10 Vdc	0–10 Volt	Linear Full Range	Engineering values associated with 0 Vdc (Min) and 10 Vdc (Max) ¹
		No Translation	N/A. The input microblock's value will be the raw voltage of the input.
2-10 Vdc	0–10 Volt	Linear w/Offset, 2–10 Volts	Engineering values associated with 2 Vdc (Min) and 10 Vdc (Max) ¹
Thermistor	Thermistor	Select your Thermistor type or set up and select a Non-Linear, Custom Table ²	N/A
Pulse to Analog (BPTA) ³			
Pulse Counter	Dry Contact or Binary Input	N/A	N/A
Binary (BBI)			
Dry Contact	Dry Contact	N/A	N/A

¹ The sensor reads a value and sends a corresponding signal (Volts) to the TV-UC683T's physical input. The Analog Input microblock uses the Min and Max values to linearly translate the signal into the engineering value used in subsequent control logic.

² You can set up a *custom translation table* (page 37) on the driver's Custom Translation Tables pages in the i-Vu® interface.

³ The control program must have one Pulse to Analog Input microblock for each pulse counting input.

Output values

Output	I/O Type	Sensor/Actuator Type	Min/Max
Analog (BAO)			
0-10 Vdc	Electrical 0-10 Volt	Linear Full Range	Engineering values associated with 0 Vdc (Min) and 10 Vdc (Max) ¹
		No Translation	N/A. The Analog Output microblock will output the same value that comes in to the microblock.
2-10 Vdc	Electrical 0-10 Volt	Linear w/Offset, 2-10 Volts	Engineering values associated with 2 Vdc (Min) and 10 Vdc (Max) ¹
Binary (BBO)			
Relay	Relay/Triac Output	N/A	N/A
Universal (BBO or BAO)			
0-10 Vdc	Electrical 0-10 Volt	Linear Full Range	Engineering values associated with 0 Vdc (Min) and 10 Vdc (Max)
		No Translation	N/A. The Analog Output microblock will output the same value that comes in to the microblock.
2-10 Vdc	Electrical 0-10 Volt	Linear w/Offset, 2-10 Volts	Engineering values associated with 2 Vdc (Min) and 10 Vdc (Max)
Relay	Relay/Triac Output	N/A	N/A
12 Vdc PWM	PWM 80 Hz	No Translation	0% (Min) and 100% (Max). The Analog Output microblock will vary the width of the pulse based on the value that comes into the microblock.

¹ The Analog Output microblock uses the Min and Max values to linearly translate its incoming value into a physical output signal (Volts) sent from the TV-UC683T to a device. For example, set Min to 0 and Max to 100 for an Analog Output microblock that receives a 0 to 100% open signal from a PID microblock and that controls a 0-10 Vdc actuator so that when the PID signal is 100%, the TV-UC683T output is 10 Vdc. Similarly, when the PID signal is 50%, the TV-UC683T output is 5 Vdc.

Resolution values

Resolution is not particular to a type of input or output, but the driver handles analog and binary inputs and outputs differently. To set these values appropriately, you should understand how the driver uses them.

Resolution	Notes
Analog Input (BAI)	The driver rounds the microblock's present value according to the resolution. EXAMPLE If the calculated present value is 13.789 and you set the Resolution to 0.1, the control program uses 13.8 for any calculations downstream from the microblock.
Analog Output (BAO)	The driver rounds the wire input value to the microblock before performing any scaling calculations. EXAMPLE If the wire input value is 13.789 and you set the Resolution to 0.1, the microblock uses 13.8 for any scaling calculations.

Offset/Polarity values

Offset/Polarity is not particular to a type of input or output, but the driver handles analog and binary inputs and outputs differently. To set these values appropriately, you should understand how the driver uses them.

Offset/Polarity	Notes
Analog Input (BAI)	Offset value (positive or negative) adds a fine adjustment to a sensor reading after all scaling for calibration. EXAMPLE If a sensor reads 74.9°F when the actual measured value is 73.6°F, enter an Offset of -1.3 to calibrate the sensor to the measured value.
Analog Output (BAO)	You can use the Offset value (positive or negative) to calibrate an output, but you generally do not need to. If used, the driver adds the offset value to the wire input value before performing any scaling calculations to determine the TV-UC683T's output.
Binary Input (BBI)	Polarity determines the microblock's present value when no signal is received from the equipment. When no signal is received from the equipment, if Polarity is set to: normal —present value is off reversed —present value is on
Binary Output (BBO)	Polarity determines the TV-UC683T's output based on the control program's signal to the microblock. When the control program's signal to the microblock is on , if Polarity is set to: normal —output is on reversed —output is off NOTE Regardless of Polarity , the output will be off if the TV-UC683T loses power.

Find and upload in the i-Vu® interface

- 1 In the i-Vu® interface, select the System level in the navigation tree.
- 2 On the **Devices** page > **Manage** tab, click **Find Devices** to discover your routers and their drivers, graphics, and touch files.
- 3 Once routers are found, select one or more routers in the list on the **Manage** tab and click **Upload All Content** to upload to the i-Vu® application. Use **Ctrl+click**, **Shift+click**, or both to select multiple items.
- 4 Click **OK** when you see the message **This will upload all content for the controller. Are you sure you want to do this?** When complete, a check mark under **Status** indicates a successful upload.

NOTES

- If an error message appears, click on the message to view an explanation.
- For details, see the i-Vu® Help.

Adjusting the TV-UC683T driver properties

After you find and upload the TV-UC683T in the i-Vu® interface, you may want to customize the TV-UC683T's settings for your applications. You can change settings on the **Driver Properties** page.

- 1 In the i-Vu® interface, right-click the TV-UC683T in the navigation tree and select **Driver Properties**.
- 2 Adjust the driver as desired.

Driver

The **Driver** page provides the following information plus the items described in the table below:

- The date/time of last parameter change or the last time the database was archived
- If control programs, properties, and schedules were successfully stored in memory
- Undelivered Alarm Status

TouchScreen Control	
TouchScreen Schedule Edit Enable	<p>Check this field to allow a user to edit this controller's schedules from an Equipment Touch or System Touch Schedules screen.</p> <p>NOTE Schedules edited on an Equipment Touch or System Touch are not uploaded to the i-Vu® application. This could result in the controller operating on a schedule that differs from the one you see in the i-Vu® interface.</p>
Controller Clock	
Clock Fall Date and Time	Date and time the controller uses when its real-time clock is invalid.
Time Synch Sensitivity (seconds)	When the controller receives a time sync request, if the difference between the controller's time and the time sync's time is greater than this field's value, the controller's time is immediately changed. If the difference is less than this field's value, the controller's time is slowly adjusted until the time is correct.
Network Microblocks	
BACnet third party integration points capacity, integration points requested, and integration points active	<p>Shows how many third-party BACnet points the TV-UC683T allows (capacity), how many points are in the control program (requested), and how many are currently active (not disabled in i-Vu®).</p> <p>For example, if the controller allows 400 points, the control program has 350 points, and you disabled 30 points in i-Vu®, you would see: Integration points capacity: 400 Integration points requested: 350 Integration points active: 320</p>
Modbus integration points capacity and integration points active	Shows how many Modbus points the TV-UC683T allows (capacity) and how many are currently active.
Number of poll retries before Network Input Microblocks indicate failure	The maximum number of retries after the initial attempt that a Network microblock will attempt to communicate with its target device. If unsuccessful, the point will transition to an idle state for 30 seconds before attempting to communicate again. Change this field only if directed by Technical Support.

Periodic rebinding Interval	If a microblock uses a wildcard in its address, this timer determines how often the microblock will attempt to find the nearest instance of its target. For example, if an outside air temperature address uses a wildcard, a VAV application will look for the outside air temperature on the same network segment or on the nearest device containing that object.
BACnet COV Throttling	
Enable COV Throttling	<p>Under normal circumstances, COV Throttling should be enabled to prevent excessive network traffic if an object's COV Increment is set too low. See EXCEPTION below.</p> <p>When enabled, if an object generates excessive COV broadcasts (5 updates in 3 seconds), the driver automatically throttles the broadcasts to 1 per second. Also, if the object's value updates excessively for 30 seconds, an alarm is sent to the i-Vu® application listing <u>all</u> objects that are updating excessively. A Return-to-normal alarm is sent only after <u>all</u> objects have stopped updating excessively.</p> <p>EXCEPTION: In rare circumstances, such as process control, a subscribing object may require COV updates more frequently than once per second. For these situations, clear this checkbox, but make sure that your network can support the increased traffic. You will also need to disable the Excessive COV alarms under the driver's Common Alarms.</p>
Trend Sampling	
Collect a daily midnight sample for all points in this controller that are sampling on COV	For values that change infrequently, select to verify at midnight daily that the point is still able to communicate trend values.
Local Network Configuration	
Allow Local Network Configuration from other devices on the local network for 24 hours	You can unlock a device for 24 hours to make IP address changes.
Debug	
Enable Debug Messages	Enable only if directed by Carrier Control Systems Support.

Device

The **Device** page provides the following information plus the items described in the table below:

- BACnet device object properties for the TV-UC683T
- The character sets supported by this device for BACnet communication
- The controller clock's time and date

Configuration	
BACnet System Status	The current state of the controller: Operational Download in Progress Download Required Backup in Progress Non-Operational
The following fields refer to all networks over which the TV-UC683T communicates.	
APDU Timeout	How many milliseconds the device will wait before resending a message if no response is received.
APDU Segment Timeout	How many milliseconds the device will wait before resending a message segment if no response is received.
Number of APDU Retries	The number of times the device will resend a message.

Notification Classes

A BACnet alarm's Notification Class defines:

- Alarm priority for Alarm, Fault, and Return to Normal states
- Options for BACnet alarm acknowledgment
- Where alarms should be sent (recipients)

Alarms in the i-Vu® application use Notification Class #1. The i-Vu® application is automatically a recipient of these alarms.

Priorities	NOTE BACnet defines the following Network message priorities for Alarms and Events.										
	<table border="1"> <thead> <tr> <th>Priority range</th> <th>Network message priority</th> </tr> </thead> <tbody> <tr> <td>00-63</td> <td>Life Safety</td> </tr> <tr> <td>64-127</td> <td>Critical Equipment</td> </tr> <tr> <td>128-191</td> <td>Urgent</td> </tr> <tr> <td>192-255</td> <td>Normal</td> </tr> </tbody> </table>	Priority range	Network message priority	00-63	Life Safety	64-127	Critical Equipment	128-191	Urgent	192-255	Normal
Priority range	Network message priority										
00-63	Life Safety										
64-127	Critical Equipment										
128-191	Urgent										
192-255	Normal										
Priority of Off-Normal	BACnet priority for Alarms.										
Priority of Fault	BACnet priority for Fault messages.										
Priority of Normal	BACnet priority for Return-to-normal messages.										

Ack Required for Off-Normal, Fault, and Normal Specifies whether alarms associated with this Notification Class require a BACnet Acknowledgment for Off-Normal, Fault, or Normal alarms.



TIP You can require operator acknowledgment for an Alarm or Return-to-normal message (stored in the i-Vu® database). In the i-Vu® interface on the **Alarm > Enable/Disable** tab, change the acknowledgment settings for an alarm source or an alarm category.

Recipient List	
Recipients	The first row in this list is from the i-Vu® application. Do not delete this row. Click Add if you want other BACnet devices to receive alarms associated with this Notification Class. NOTE Additional entries in this table may be lost after a download.
Recipient Description	Name that appears in the Recipients table.
Recipient Type	Use Address (static binding) for either of the following: <ul style="list-style-type: none"> • Third-party BACnet device recipients that do not support dynamic binding • When you want alarms to be broadcast (you must uncheck Issue Confirmed Notifications). This use is rare.
Days and times	The days and times during which the recipient will receive alarms.
Recipient Device Object Identifier	Type the Device Instance from SiteBuilder (or from the network administrator for third-party devices) in the # field.
Process Identifier	Change for third-party devices that use a BACnet Process Identifier other than 1. The i-Vu® application processes alarms for any 32-bit Process Identifier.
Issue Confirmed Notifications	Select to have a device continue sending an alarm message until it receives delivery confirmation from the recipient.
Transitions to Send	Uncheck the types of alarms you do not want the recipient to get.

Calendars

Calendars are provided in the driver for BACnet compatibility only. Instead, use the **Schedules** feature in the i-Vu® interface.

Common Alarms

On these pages, you can enable/disable, change BACnet alarm properties, or set delays for the following BACnet alarms:

Common alarms:

- Duplicate Address
- Control Program
- Controller Halted
- Locked I/O
- Program Stopped
- Excessive COV
- All Programs Stopped

Controller Generated Alarm	
Description	Short message shown on the i-Vu® Alarms page or in an alarm action when this type of alarm is generated.
Events	
Alarm Category and Alarm Template	See <i>Setting up an alarm source in the i-Vu® interface</i> in i-Vu® Help.
Enable	Clear these checkboxes to disable Alarm or Return to normal messages of this type from the TV-UC683T.
Notification Class	In a typical i-Vu® system, the Notification Class is 1; however, if needed, you can associate a different notification class with the alarm. See <i>Notification Classes</i> (page 34) to set up alarm delivery options for a specific Notification Class.

Specific Events

On these pages, you can enable/disable, change BACnet alarm properties, or set delays for the following BACnet alarms:

Specific alarms:

- Flow Control Alarm
- Reheat Valve Alarm

NOTE To set up alarm actions for controller generated alarms, see *Alarms* in i-Vu® Help.

Controller Generated Alarm	
Description	Short message shown on the i-Vu® Alarms page or in an alarm action when this type of alarm is generated.
Events	
Alarm Category and Alarm Template	See <i>Alarms</i> in i-Vu® Help.
Enable	Clear these checkboxes to disable Alarm or Return to normal messages of this type from this controller.
Notification Class	Do not change this field.

Custom Translation Tables

You can set up a translation table that an analog input will use to translate the raw data from a non-linear sensor to the engineering units you want it to provide on the output wire of the Analog Input microblock. In the navigation tree, select **Custom Translation Table #1, #2, or #3**. The **Properties** page has instructions.

For the input to use the translation table, go to the control program's **Properties** page > **I/O Points** tab. Click the analog input in the **Name** column. On the **Details** tab, set **Sensor Type (Scaling Method)** to **Non-Linear, Custom Table #__**.

BACnet Controller Properties

The **BACnet Controller Properties** page provides the following information plus the items described in the table below:

- The TV-UC683T's Ethernet MAC address
- Whether **Port S1** is being used for MS/TP, Modbus, or is disabled

NOTE The options shown on the page change according to your controller's settings.

MS/TP Configuration on Port S1	
Address	For Port S1—A unique address on the MS/TP network.
MS/TP Autobaud	To enable autobaud, select Yes . This device will receive its baud rate from the master device.
MS/TP Baud Rate	Set this to a baud rate that all other devices on the MS/TP network are set to.
Max Masters	To increase MS/TP performance, enter the highest address used on the MS/TP network for a master controller. This number must be less than or equal to 127.
Max Info Frames	This is the maximum number of information messages a controller may transmit before it must pass the token to the next controller. Valid values are 1 to 255.  TIP Set Max Info Frames to a number in the range 20 to 100 so that the router does not become a bottleneck for traffic being routed from a high-speed network to the slower MS/TP network.
End of Network Switch Status	
Port S1 End of Network	This displays the state of the End of Net? termination switch for Port S1.
IP Configuration	
Allow setup of IP addressing through an external tool	When this field is enabled, you can set up IP addressing through a tool. IP addressing is typically set up through the Service Port.
Enable IP configuration changeover	Only for custom static IP addressing—Select this field to remotely change the controller's IP Address , Subnet Mask , and Default Gateway Address . Type the new addresses and the UDP Port that your server is using to communicate to all controllers. In the Changeover timeout field, enter: <ul style="list-style-type: none"> • A specific length of time for the controller to attempt to communicate with the Next Default Gateway Address. The controller will use the Next setting as soon as the controller can communicate with the Next Default Gateway Address, or when the timeout occurs, whichever comes first. • 0:00 to have the controller use the Next settings as soon as the controller can communicate with the Next Default Gateway Address. See "To remotely change a controller's IP address" in i-Vu® Help for more information on using this feature.

BACnet Firewall

If this IP controller is accessible from the Internet, you can increase security by enabling its BACnet firewall. When enabled, this feature prevents the controller from responding to BACnet messages from unidentified sources and allows communication only with IP addresses that you define. These can be all private IP addresses and/or a list of IP addresses. Follow the instructions in the i-Vu® interface to set up the BACnet firewall.

Network Diagnostics - Statistics

This page shows the network statistics for each of the TV-UC683T's ports that are in use. This same information is provided in a *Module Status report* (page 58).

Click the **Error Rate Trend** or **Packet Rate Trend** link at the bottom of each section to see the statistics displayed as trend graphs. You can also access these trends by clicking on the driver in the network tree, and then selecting **Trends > Enabled Points >** and the desired trend graph.

Click a port's **Reset** button to set all of the numbers to zero so the counting can start over.

Controller Statistics	
Error Counters	Dropped Packets —Data packets that could not be delivered.
	Route Not Found —Packets that could not be delivered because the requested network does not exist.
	Route Unreachable —These are routed packets whose destination network is either busy or offline.
Controller Sourced Packets	Shows the number of packets initiated by the TV-UC683T that are not in response to a request from another device. The numbers in this table will also appear in the appropriate columns in the Network Activity tab.
Eth0/Eth1 Port Statistics	
BACnet/IP Statistics	BACnet/IP Rx Unicast Packets —BACnet/IP packets received from a single BACnet device.
	BACnet/IP Tx Unicast Packets —BACnet/IP packets transmitted to a single BACnet device.
	BACnet/IP Rx Broadcast Packets —BACnet/IP broadcast packets received by the TV-UC683T.
	BACnet/IP Tx Broadcast Packets —BACnet/IP broadcast packets transmitted by the TV-UC683T.
	Whitelist Rejections (if <i>BACnet Firewall</i> (page 38) is enabled)—Messages blocked by the BACnet Firewall because the IP address that sent the message was not in the whitelist.
Ethernet Statistics	Ethernet Rx packets —All packets (including non-BACnet packets such as a ping) received by the TV-UC683T.
	Ethernet Tx packets —All packets (including non-BACnet packets such as a ping) transmitted by the TV-UC683T.
	Receive Errors (total) —All errors related to received packets such as CRC errors, FIFO errors, frame errors, length errors, missed errors, and overrun errors.
	Transmit Errors (total) —All errors related to transmitted packets such as aborted errors, carrier errors, dropped errors, FIFO errors, heartbeat errors, and window errors.
	Dropped Packets —Packets dropped by the TV-UC683T's Ethernet interface.
Trends	Error Rate Trend —Shows the total number of errors within the interval time.
	Packet Rate Trend —Shows the total number of packets transmitted and received within the trend sampling interval

Network Diagnostics - Packet Capture

This page allows you to capture network communication on a port and then download the capture file for troubleshooting. Choose one of the following capture options:

- **Start/Stop** - Define the start and stop criteria, and then click **Start** and **Accept** to begin the capture. When the capture stops, the capture file is generated.
NOTE If a Start/Stop capture is running on any other port, the **Get capture file** button will be disabled until all Start/Stop captures have completed.
 - **Start capture:** - When you check **At (mm/dd/yyyy hh:mm AM/PM)**, enter the time and date, and click **Start**, the packet capture begins at the date and time you specified.
NOTE The hours field is validated from 0 to 12, and minute field is validated from 0 to 59.
 - **Continuous** - Click **Start** and **Accept** to begin the capture. Click **Save** to momentarily stop the capture and create the capture file. The capture will automatically resume. Click on the **Start/Stop** option to end the **Continuous** capture.
 - If the port is set up for MS/TP, select an option in the **Capture** section.

To download the capture file

Capture files are Wireshark files that are added to the Device Log Archive .tgz file. Do the following to view the files.

- 1 If you do not have Wireshark installed on your computer, download the latest version from the *Wireshark website* (<http://www.wireshark.org>).
- 2 Run the install program, accepting all defaults. Include WinPcap in the installation.
- 3 On the i-Vu® **Packet Capture** page, click **Get capture file** to download the .tgz file. The message appears "Retrieving the file, this may take a little while". Click **OK**.

NOTE If the size of the .tgz is large, there could be a considerable delay (for example, over 2 minutes) after you click **Get capture file** until your browser begins the download.

- 4 Open the .tgz file. The files are in the **captures** folder.

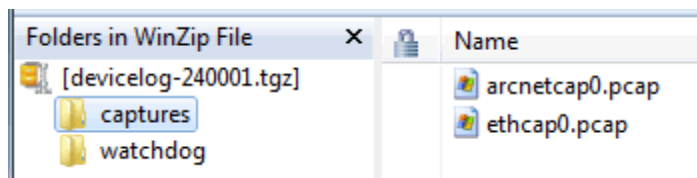

Capture file names are based on the ports.

NOTE Clicking **Get capture file** generates the port's .pcap file. If the port has a .pcap file from a previous capture, that file will be overwritten.

- 5 Extract the .pcap file from the .tgz file.
- 6 Open the .pcap file in Wireshark.

Act Net Bus

Act Net Bus Status

An Act Net device that is physically connected to the TV-UC683T is automatically identified and the serial number and current status are displayed on the **Act Net Bus** page.

NOTE You can edit the address and description on this page. Applying changes can take up to 20 seconds to complete.

Act Net Bus Status	This table shows devices connected to the Act Net port. All fields are read-only.	
Device Address	Act Net device address (1 to 5). The same address is used as exp# in the microblock configuration with the input/output number for all Act Net devices set to 1.	
Device Description	This text is editable in the Act Net Bus Configuration table directly below.	
Serial Number	The serial number of the Act Net device. This number is printed on a label on the device.	
Device Status	Displays the current status of the device	
	Possible statuses	Description
	Normal Operation	Successful communication
	No Communication with the device	TV-UC683T has lost communication with the Act Net device
	Duplicate Address on the network	More than one device has the same Device Address.
	Unsupported Device Type	Device is not recognized
	Act Net Wiring Error	Loopback error on Act Net bus, possibly caused by wiring problem or hardware failure.
Act Net Bus Configuration	This table shows devices connected to the Act Net port. Most fields are editable.	
Current Address	Bus address of the Act Net device	
Device Description	Edit the name if needed.	
Serial Number	Serial Number of the device corresponds to Current Address in the same row. This field is read-only if the corresponding device is in communication, otherwise becomes editable so that user can enter the serial number manually (can be found as a label on the actuator).	
New Device Address	Select a new bus address from the drop-down list.	

Configuration Status		Once all changes are accepted, after applying changes this fields shows success/fail statuses.
	Possible statuses	Description
	Success	Address selection successful. It may take a few seconds to updates in the status table. Please refresh the page to see the updated status table.
	In Progress	This string appears after accepting the changes and before success/fail messages are appeared. This message may not appear all the time due to data refresh rate.
	Invalid serial number format	A serial number that was entered manually has an invalid format. Correct format example: 01647-20212-250-160
	Device not found	Serial number format is valid, but the device with the number cannot be located.
	Select unused address	If the New Device Address is a duplicate, select an unused address from the drop-down list. To update the table, click Accept after every change.
	Unknown Error	Firmware or bus error.
	Auto addressed device	When a device that does not have an address is found on the bus, an unused address in automatically assigned. You can select a different address in the New Device Address field, if needed.

To resolve duplicate addresses on Act Net bus

When devices display the error **Duplicate Address on the network**, you can use either of the following methods to resolve the problem.

- Method 1: Using the **Act Net Bus Configuration** table
 1. For each duplicate device, enter the **Serial Number**, which you can find on a sticker on the device.
 2. Select a **New Device Address** from the drop-down list.
 3. Click **Accept**.
 4. Verify that there are no longer any **Duplicate Address on the network** errors.

- Method 2: Reinstalling the devices
 1. Remove all duplicate devices from the bus.
 2. Connect one of the removed devices and wait for the **Act Net Bus Status** table to update.
 3. Chose a unique address for the new device and click **Accept**. Wait until the operation is successful.
 4. Repeat the steps 2 and 3 for the remainder of the removed devices.
 5. Verify that there are no longer **Duplicate Address on the network** errors.

Communication Status

The **Communication Status** page shows the status of the protocols currently running on the TV-UC683T's ports.

Standalone Controller Detection

You can use the fields on this page with a binary input in your control program to detect when the controller does not receive a write request from the selected network within the specified amount of time. The input remains OFF as long as write requests are received, but switches to ON if the controller does not receive a request within the specified time. The binary input must have the Expander number and Input number set to **99** and the I/O Type set to **Special**.

Modbus Serial, Modbus TCP/IP, and Modbus Error Definitions pages

If the controller will be used with Modbus devices, see the *Modbus Integration Guide* for information on using these pages.

Flow Calibration Archive

NOTE This driver property only applies to controllers with built-in airflow sensors.

The **Flow Calibration Archive** page shows measured flow and sensor readings that were entered in the i-Vu® Test and Balance tool or through the stand-alone Test & Balance Utility.

To set up Network Statistic trends

PREREQUISITE To view Network Statistic trends, you must have a i-Vu® v6.5 or later system with the latest cumulative patch.

To view the *Network Statistics* (page 39) as trend graphs, select the controller in i-Vu®'s navigation tree and go to one of the following:

- On the **Driver Properties > Network Diagnostics > Statistics** page, click a **Trend** link at the bottom of each section.
- Click the **Trends** drop-down button, select **Enabled Points** and then the graph you want.

You can define:

- How the graph looks on the trend's **Configure** tab.
- How you want trend samples to be collected on the **Enable/Disable** tab. See table below.

Field	Notes
Sample every _:._ (hh:mm:ss)	(Recommended method) To record the value at a regular time interval, enter hh:mm:ss in this field.
Sample on COV (change of value)	To record the value only when the value changes by at least the amount of the COV Increment , set the Sample every field to 0:00:00 and enter a value in the COV Increment field.
Max samples	Network Statistic trends have a non-configurable maximum trend log buffer size of 1440. NOTE Trending consumes memory in the controller. Click Reset to delete all samples currently stored in the controller.
Stop When Full	Check this field to stop trend sampling when the maximum number of samples is reached.
Enable trend log at specific times only	Collects trend data for the specific period of time you define in the time and date fields.
Enable Trend Historian	Archives trend data to the system database.
Store Trends Now	Writes all trend data in the controller to the system database without having to enable trend historian.
Write to historian every __ trend samples	Writes all trend data in the controller to the system database each time the controller collects the number of samples that you enter in this field. This number must be greater than zero and less than the number entered in the Max samples field. The number of trends specified must be accumulated at least once before the historical trends can be viewed. NOTE Any trends not stored in the historian will be lost if the controller loses power.
Trend samples accumulated since last notification	Shows the number of samples stored in the controller since data was last written to the database.
Last Record Written to Historian	Shows the number of trend samples that were last written to the database.
Keep historical trends for __ days	This is based on the date that the sample was read. Select the first option to use the system default that is defined on the System Options > System Settings > General tab. Select the second option to set a value for this trend only.

To set up the controller through the Service port

You can communicate with the TV-UC683T through a web browser by connecting a computer to the controller's Service Port using either the Carrier wireless service adapter or a USB cable.

NOTE You cannot access the Service port by plugging an Ethernet cable into Eth0 or Eth1.

Once you are connected to the network, you can:

- Access the controller setup pages
- Address and configure controllers
- View the controller's Module Status report
- View/change controller and network settings. Changes take effect immediately.
- Troubleshoot
- Use BACnet/Service port to access the i-Vu® application or a touchscreen device. See *To communicate through a BACnet/Service port network* (page 45).

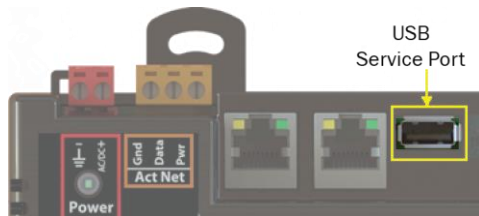

To access the controller setup pages and use the **Local Network** tab, you must first connect to and manually address one TV-UC683T. For instructions on connecting, see *Addressing the TV-UC683T through the Service port* (page 9). Navigate to <http://local.access> or <http://169.254.1.1> to access the pages. Then set up the address on your selected TV-UC683T on the **Ports** tab (page 46).

NOTE The first time you access the controller in the i-Vu® interface, after you have changed settings through the Service port, be sure to upload the changes to the system database. This will preserve those settings when you download memory or parameters to the controller.

ModStat tab

This tab provides the controller's Module Status report that gives information about the controller and network communication status. See *Appendix - Module Status field descriptions* (page 64).

To set up the controller through the Service port

Device tab

BACnet Object	
Device Instance	Autogenerated —(Default) The Device Instance is automatically set to a number using the IP Address, Subnet information, and the Carrier vendor ID 16. Assigned —Lets you enter a specific number that is unique on the BACnet network.
Device Name	Autogenerated —(Default) The Device Name is automatically set as the word device + the Device Instance. For example, device2423911. Assigned —Lets you enter a specific name that is unique on the BACnet network.
Device Location	You can enter an intuitive location for the device in the i-Vu® interface.
Device Description	You can enter an intuitive description for the device in the i-Vu® interface.
Configuration	
APDU Timeout	How many milliseconds the device will wait before resending a message if no response is received.
APDU Segment Timeout	How many milliseconds the device will wait before resending a message segment if no response is received.
APDU Retries	The number of times the device will resend a message.
Controller Information	
Clear Counts/Logs	Clears Reset counters and the three message history fields from the Module Status.
Data Backup and Restore	
Backup	Displays time of the last backup. Click button to backup the controller's control programs, properties, and schedules.
Restore	Displays time of the last restore. Click button to restore the most recent backup of the controller's control programs, properties, and schedules.

Ports tab

IP Port	
IP Addressing	Select the type of addressing the controller is to use. See <i>Addressing the TV-UC683T</i> (page 9).
Ethernet Port	
Address	A factory assigned Ethernet MAC Address for the Eth0 and Eth1 ports.
Port S1	
End of Network	Indicates status of the controller's End of Net? switch.
Protocol	Change active protocol, if needed.
Active Protocol	Indicates the active protocol on Port S1 Configuration .

BACnet tab

NOTE The TV-UC683T can be configured for only one BACnet communication type.

On the **BACnet** tab, you can choose to run **BACnet Over IP** or **BACnet Over Ethernet** on the **Eth0** and **Eth1** ports. If you choose **BACnet Over IP**, you can edit the **BACnet UDP Port**.

Modbus tab

If the controller will be used with Modbus devices, see the *Modbus Integration Guide* for information on using this tab.

Security tab

BACnet Firewall

If your BACnet Firewall configuration in the i-Vu® interface did not include the i-Vu® server IP address, thus blocking communication with the i-Vu® server, you can disable the controller's BACnet Firewall on the controller setup **Security** tab.

NOTE You can enable the BACnet Firewall only in the i-Vu® interface.

Local Network tab

Use the **Local Network** tab to:

- Discover 256 TruVu™ devices on a single network at a time.
- Discover both configured or unconfigured devices on this controller's network.
- See the number of devices discovered and the total number on the network.
- Identify the TruVu™ controller that has had its DSC button pressed.
- Export the **Local Devices** that are present in the table (limited to 256) to a .csv file.
- Set a device's **Mode**, **Address**, and **Location**.
- Assign IP addresses to multiple devices at one time.
- Prompt an LED to blink on a device.

To set up the controller through the Service port

A device that is new from the factory or has not been previously configured with an IP address, can always be configured using the **Local Devices** table. However, once you have assigned a valid IP address, you have up to 24 hours to make any other changes. After 24 hours, the fields are not editable and the device is **Locked**.

You can unlock a device for 24 hours by either pressing the DSC button on the TV-UC683T controller or by using the i-Vu® application. In the i-Vu® navigation tree, right-click the TV-UC683T, select **Driver Properties** and go to **Driver > Settings** tab > **Local Network Configuration**. Check **Allow Local Network Configuration from other devices on the local network for 24 hours** and click **Accept**.

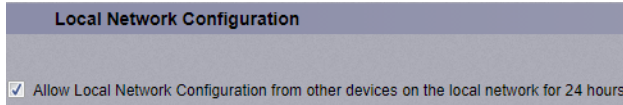

To discover devices on a network

- 1 To address a network of devices, you must first select one TruVu™ controller and set the **IP Address**, **Subnet Mask**, and **Default Gateway** on the **Ports** tab.

NOTE This controller is referred to as the connected controller.

- 2 On the **Local Network** tab, at the top of the page, verify that the connected controller's **Mode**, **IP Address**, **Subnet Mask**, and **Default Gateway** are accurate.
- 3 Use the following settings to define the devices that you want to discover in the **Local Devices** table.

Local Devices	
Only Unconfigured	When checked, only discovers devices that do not have an IP address and are linked to the connected controller's network. When unchecked, discovers both configured and unconfigured devices.
Clear All	Erases all information in the table.
Export	Creates .csv file of the data in the table, limited to 256 devices.

- 4 Click **Discover** to populate the table with your TruVu™ devices that are on a single network communicating with the connected TruVu™ controller.

To auto-assign IP addresses to multiple devices at one time

- 1 Follow the above steps to **Discover** devices.
- 2 In the **Select** column, click the checkbox for the devices you want to assign addresses to.
NOTE To change the IP Address, the device's **Mode** must be **Custom Static**.
- 3 Enter the starting IP address under **Address** and click **Assign** to automatically assign sequential IP addresses.

There are different workflows for using the **Local Devices** table to address your devices, depending on the information you have from the installation. See *To address when you know the serial numbers* (page 13) or *To address when you do not know the serial numbers* (page 14).

Local Devices table	
Select	<p>Check to select devices for:</p> <ul style="list-style-type: none"> • Changing the Mode • Resolving a Mismatch • Auto-assigning an IP Address <p>NOTE You cannot select devices with a lock symbol.</p>
MAC	Ethernet MAC address of device
Serial#	<p>The discovered devices are in order by serial number.</p> <p>NOTE To change how the rows are sorted, click a different column heading.</p>
Mode	<p>To change the Mode:</p> <ol style="list-style-type: none"> 1 Select the devices you want to change. 2 Select one of the following IP addressing modes: <ul style="list-style-type: none"> • Default IP - Devices with rotary switches that are used when autogenerating the address (if applicable) • Custom Static - A permanent IP addresses which does not change and is usually obtained from the network administrator • NOTE Selecting this automatically sets the device's subnet and default gateway to match the connected controller. • DHCP - Allows the DHCP server to automatically assign an IP address 3 Click the Set button.
Address	<p>Displays the IP address of the device, if assigned. You can edit the address only if the device is set to Custom Static.</p> <p>To auto-assign multiple sequential addresses, select the devices, enter the beginning address, and click Assign.</p>
Location	You can describe the location of the device or any other helpful information.
Mismatch	<p>A Mismatch occurs when the connected controller's mode is set to Custom Static and a discovered device's subnet and default gateway do not match the connected controller. The incorrect addresses are shown with SN for subnet and GW for default gateway.</p> <p>To resolve a mismatch, select the device(s) by clicking the Select checkbox and then clicking the Resolve button. The subnet mask and default gateway addresses of the selected devices change to match the connected controller.</p>

To set up the controller through the Service port

Local Devices table

Status

The following are the results of changing **Mode**, **Address**, **Location**, or pressing **Blink**:

- **Success** - Successful operation
- **No Response** - Device is not communicating
- **Device Locked** - Device must be unlocked before you can make any changes using the **Local Devices** table. You can unlock the TV-UC683T by pressing the DSC button on the device or by using the i-Vu® application. (See instructions above.)
NOTE The status of a device changes to locked 24 hours after unlocking it.
- **Failure** - A conflict between the device and the information entered

Blue dot

A blue dot appears for the most recent device to have the:

- **Blink** button clicked in the table
- **Address** or **Location** entered
- DSC button pressed on the device

NOTE If the device is not already listed in the table, pressing the DSC button immediately adds it to the table and displays a blue dot.



TIP You can build a table of devices in the order that you've pressed the DSC buttons. Clear the table and then press each DSC button in turn. The devices will be listed in the table in the order in which the button was pressed, but only the most recent one will show the blue dot.

Blink

Click the **Blink** button to prompt the Locator LED to flash for 15 seconds, allowing you to verify the controller's physical location. After flashing, whenever the actuator moves, the LED rotates in the same direction. LED rotation is automatically disabled after 1 hour and can be re-enabled by pressing the **Blink** button again.

At the same time, the **Sys** and **Net** LEDs blink white, once per second for 10 seconds, and then stop.

NOTES

- The blue dot appears when you **Blink** a device.
- You can **Blink** a locked device.

NOTE If a device's IP address is the loopback address (127.0.0.1), it is considered unconfigured and unlocked. The IP address, subnet mask, and default gateway fields are blank in the **Ports** and **Local Network** tabs. You can configure it in the **Local Devices** table.

To communicate through the BACnet/Service port network

You can connect to the Service port to access your network through the i-Vu® application.

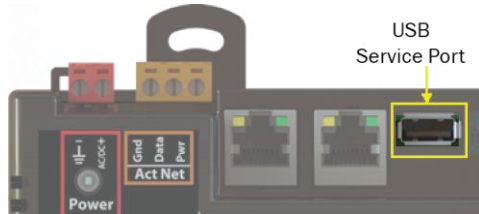

See *Addressing the TV-UC683T through the Service port* (page 9) to set up your connection to the web browser if you haven't already.

- 1 Open a web browser on the computer and launch your i-Vu® application.
- 2 In the i-Vu® interface, on the **System Options** tree, select **Connections**.
- 3 On the **Properties** page > **Configure** tab, select **BACnet/IP Service Port Connection** from the drop-down list and click **Add**.
- 4 If needed, enter the **Service Port Network Number** as follows:
 - **0** - the TV-UC683T will communicate only with the computer or TruVu™ ET Display
 - **1 to 65534** - the TV-UC683T's network number for network communication
 - **65535** - searches for an available network number from 65531 to 65534. If any of these numbers are not available, you will have to assign a network number and enter it.
- 5 Click **Apply**.
- 6 On the right of the page, in the **Networks using selected connection** table, click the checkbox next to the network you want to connect to.
- 7 Click the **Start** button. The status changes to **Connected**.
NOTE If an error message appears, make sure the COM port you selected is not in use. For example, PuTTY may be open and holding the port open.
- 8 Click **Accept**.
- 9 Open a web browser on the computer and login to your i-Vu® Pro application.
- 10 In the i-Vu® Pro interface, on the **System Options** tree, select **Connections**.
- 11 On the **Properties** page > **Configure** tab, Select **BACnet/IP Service Port Connection** from the drop-down list and click **Add**.
- 12 If needed, enter the **Service Port Network Number** as follows:
 - **0** - the TV-UC683T will communicate only with the computer or TruVu™ ET Display
 - **1 to 65534** - the TV-UC683T's network number for network communication
 - **65535** - searches for an available network number from 65531 to 65534. If any of these numbers are not available, you will have to assign a network number and enter it.
- 13 Click **Apply**.

To communicate through the BACnet/Service port network

- 14 On the right of the page, in the **Networks using selected connection** table, click the checkbox next to the network you want to connect to.
- 15 Click **Apply**.
- 16 Select the **BACnet/IP Service Port Connection** and click **Start**. The status changes to **Connected**.
- 17 Click **Accept**.
- 18 On the navigation tree, right-click the controller that you are connected to and select **Module Status**. If a Modstat report appears, the i-Vu® application is communicating with the controller.

To communicate locally through the Rnet port

You can connect a computer running Field Assistant to the TV-UC683T's **Rnet** port to download or troubleshoot.

PREREQUISITES

- A computer with a USB port
- A USB Link (Part #USB-L)
- For the Field Assistant application to communicate with the controller, the controller must have been downloaded with at least its driver.
- A 3-pin screw terminal connector and 3-wire cable



CAUTIONS

- Maintain polarity when controllers share power.
- Failure to maintain polarity while using the USB Link on a computer that is grounded via its AC adapter may damage the USB Link and the controller.
- If multiple controllers share power but polarity was not maintained when they were wired, the difference between the controller's ground and the computer's AC power ground could damage the USB Link and the controller. If you are not sure of the wiring polarity, use a USB isolator between the computer and the USB Link. Purchase a USB isolator online from a third-party manufacturer. Plug the isolator into your computer's USB port, and then plug the USB Link cable into the isolator.

- 1 The USB Link driver is installed with a v6.5 or later system. Please refer to the Silicon Labs website and search "CP210x USB to UART Bridge VCP Drivers" for the most current device drivers. Install the driver before you connect the USB Link to your computer.
- 2 Connect one end of a piece of 3-wire cable to the 3-pin connector.

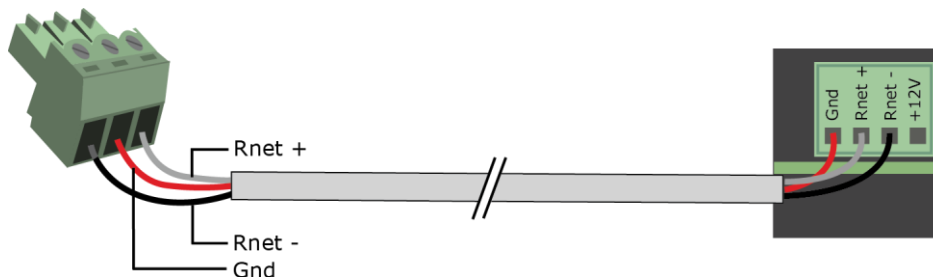

- 3 Connect the other end of the 3-wire cable to the TV-UC683T's **Rnet** port as shown in the drawing above in step 1.
- 4 Connect the 3-pin connector to the portion of the USB link kit shown in the drawing below, then connect the USB connector to the computer.

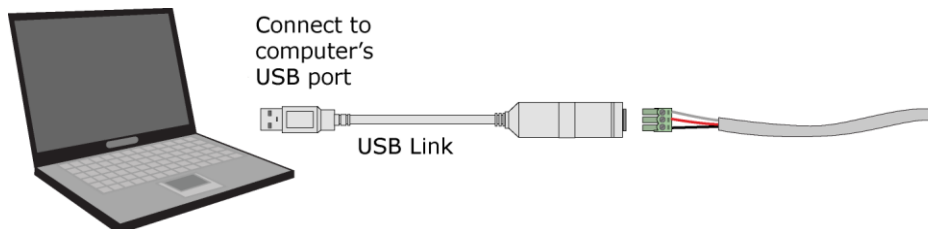

To communicate locally through the Rnet port

To set up a Local Access connection in the i-Vu® interface

For the i-Vu® Pro application to communicate with the **Rnet** port, you must do the following:

- 1 Click , select **System Options > Connections**.
- 2 On the **Configure** tab, click **Add**.
- 3 From the **Type** drop-down list, select **BACnet/Rnet Connection**.
- 4 Optional: Edit the **Description**.
- 5 Type the computer's **Port** number that the USB cable is connected to.

NOTE To find the port number, plug the USB cable into the computer's USB port, then select **Start > Control Panel > System > Device Manager > Ports (Com & LPT)**. The COM port number is beside **Silicon Labs CP210x USB to UART Bridge**.

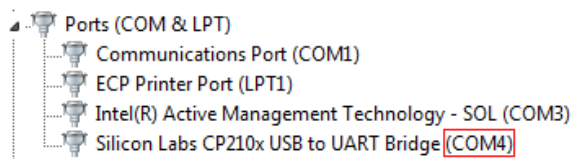

- 6 Set the **Baud** rate to 115200.
- 7 Click **Apply**.
- 8 On the right of the page, in the **Networks using selected connection** table, click the checkbox next to the network you want to connect to.
- 9 Click **Apply**.
- 10 Select **BACnet/Rnet Connection**, then click **Start**.

NOTE If an error message appears, make sure the COM port you selected is not in use. For example, PuTTY may be open and is holding the port open.

- 11 Click **Close**.
- 12 On the navigation tree, select the controller that you are connected to.
- 13 Click , and select **Manual Command**.
- 14 Type `rnet here` in the dialog box, then click **OK**.
- 15 On the **Properties** page, click **Module Status**. If a Modstat report appears, the i-Vu® application is communicating with the controller.

Troubleshooting

If you have problems mounting, wiring, or addressing the TV-UC683T, contact Carrier Control Systems Support.

LEDs

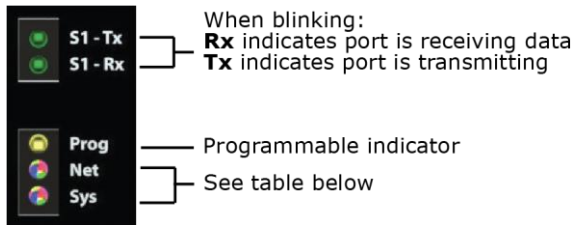

Net (Network Status) Tricolor LED

Color	Pattern	Condition	Message in Module Status	Possible Solutions
Red	On	Ethernet connection problem	No Ethernet Link	<ul style="list-style-type: none"> Connect Ethernet Cable Check other network components
Red	1 blink	One of the following BACnet/IP (Ethernet) DLL reporting issue: <ul style="list-style-type: none"> Unable to create tasks Unable to open socket for BACnet port 	BACnet/IP error	Cycle power
Blue	On	One of the following issues: <ul style="list-style-type: none"> Port communication firmware did not load properly Port communication firmware is not running Invalid protocol selected 	MSTP firmware error	<ul style="list-style-type: none"> Change protocol using USB Service Port Cycle power
Blue	1 blink	Invalid address selected for protocol	Invalid address selection for MSTP	Change MAC address to unique address using USB Service Port
Blue	2 blink	Controller has same MAC address as another connected device	Duplicate address on MSTP	Change MAC address to a unique value using USB Service Port to valid address
Blue	3 blink	Controller is the only device on the network	No other devices detected on MSTP	<ul style="list-style-type: none"> Check that network cable is connected properly Check that baud rate is correct

Color	Pattern	Condition	Message in Module Status	Possible Solutions
Blue	4 blink	Excessive errors detected over 3 second period	Excessive communication errors on MSTP	<ul style="list-style-type: none"> Check that network cable is connected properly Check that baud rate is correct
Green	On	All enabled networks are functioning properly	No errors	No action required
Magenta		Operating system changes are downloading WARNING This process could take several minutes. Do NOT power off the controller during the download.	N/A	No action required
White	1 blink every second for 15 seconds	The Blink button on the controller setup Local Network tab has been pressed	N/A	No action required

Sys (System Status) Tricolor LED

Color	Pattern	Condition	Message in Module Status	Possible Solution
Red	2 blink	Restarting after an abnormal exit	Auto restart delay due to system error on startup	After 5 minute delay has expired, if condition occurs again then cycle power
Red	4 blink	Firmware image is corrupt	Firmware error	Download driver again
Red	Fast blink	Firmware error has caused the firmware to exit and restart	Fatal error detected	No action required
Green	1 blink	No errors	Operational	No action required
Green	2 blink	Download of driver is in progress	Download in progress	No action required
Green	3 blink	BACnet Device ID is not set	Download required	Download the controller
Green	Fast blink	Installation of recently downloaded driver is occurring	N/A	No action required
Blue	On	Controller is starting up	N/A	No action required
Blue	Slow blink	Linux (operating system) is starting up	N/A	No action required

Color	Pattern	Condition	Message in Module Status	Possible Solution
Blue	Fast blink	Linux is running but it could not start the firmware application	N/A	Download driver
Magenta		Operating system changes are downloading WARNING This process could take several minutes. Do NOT power off the controller during the download.	N/A	No action required
White	1 blink every second for 15 seconds	The Blink button on the controller setup Local Network tab has been pressed	N/A	No action required

To configure custom Prog LED

You can customize the **Prog** LED for site-specific purposes by configuring the BACnet Analog Output (BAO) microblock.

Open your control program in the Snap interface, select the AO microblock for the LED, and use the following settings:

Status/Attribute	Microblock type	Expander number : Channel number	I/O type	Description
LED	BAO	0:61	Special	<ul style="list-style-type: none"> • <=0 Normal • >15 On <p>The number of blinks equals the Present Value.</p> <p>The pulse pattern repeats after a 2-second delay</p> <p>LED will blink the number of times given in the BAO with ON pulse 0.5 seconds and OFF pulse 0.5 seconds.</p>

To get a Module Status report

A Module Status report provides information about the controller and verifies proper network communication with the controller. You can get this report:

- In the i-Vu® application—Right-click the controller on the navigation tree, then select **Module Status**.
- In the Field Assistant application—Right-click the controller in the navigation tree and select **Module Status**.
- On the controller setup **ModStat** tab—See *To set up the controller through the Service Port* (page 45).

See *Module Status field descriptions* (page 64) in the Appendix.

Troubleshooting inputs and outputs

The i-Vu® interface shows if you have I/O errors resulting from:

- A misconfigured microblock
- A misconfiguration on the expander
- A missing or disconnected expander

To check for errors:

- 1 In the i-Vu® navigation tree, select the equipment controlled by the .
- 2 On the **Properties** page, select the **I/O Points** tab.
- 3 Click the **Name** of any input or output whose name is red (indicates an error) to open its dialog box.

Name	Type	Value
Zone Temp	(BAI)	72.0 °F
Fan Control	(BBO)	On

- 4 On the **Details** tab, scroll down to see the **Reliability** field under **BACnet Configuration**.

BACnet Configuration

Network Visible: (Must be enabled for other BACnet objects to read or write to th

Object Name: Reliability: **Communication Failure**

Object Id: **Binary Output 4, #2**

- 5 Anything other than **No Fault Detected** indicates an error. See the table below to determine the error and possible actions to take.

Reliability description	Possible error	Verify that...
Communication Failure	<ul style="list-style-type: none"> • Expander is not connected to the controller. • The expander has no power. • The controller is offline. 	<ul style="list-style-type: none"> • The expander is connected to the controller's I/O bus edge connector or wired to the I/O Bus port. • The expander has power.
Configuration Error	<ul style="list-style-type: none"> • The microblock's I/O Type and Sensor/Actuator Type are not compatible. • The output's DIP switch setting does not match the connected device. • Invalid expander address or I/O number. 	<ul style="list-style-type: none"> • The I/O Type and Sensor/Actuator Type combination is valid for the I/O number and microblock type. • The DIP switch setting is appropriate for the output and microblock type. • The expander is present and functional at the address shown in the i-Vu® interface and that I/O number is valid.
Over Range	<ul style="list-style-type: none"> • Input exceeds the Min/Max limits. 	<ul style="list-style-type: none"> • The input is within the Min/Max limits.
No Output	<ul style="list-style-type: none"> • Output's Hand-Auto-Off switch is in Hand or Off position. 	<ul style="list-style-type: none"> • The expander's Hand-Auto-Off switch is in the Auto position.
No Sensor	<ul style="list-style-type: none"> • No device is attached to the output. 	<ul style="list-style-type: none"> • The device is present and functioning.
Shorted Loop	<ul style="list-style-type: none"> • Internal voltage feedback does not correspond with commanded value. 	<ul style="list-style-type: none"> • The load on the output is within the valid range. • A voltage/current source has not been connected to an output.
Open Loop	<ul style="list-style-type: none"> • Internal current feedback does not correspond with commanded value. 	<ul style="list-style-type: none"> • The load on the output is within the valid range. • A voltage/current source has not been connected to an output.
Unreliable Other	<ul style="list-style-type: none"> • Feedback from the expander does not correspond with commanded value (for example, the output relay is not in commanded state). 	<ul style="list-style-type: none"> • Expander may be faulty. Contact Technical Support.

To get a Device Log

If Carrier Control Systems Support instructs you to get the controller's Device Log containing diagnostic information for troubleshooting:

- 1 Select the TV-UC683T in the i-Vu® navigation tree.
- 2 On the **Properties** page, click **Device Log**.

NOTE You can click **Device Log Archive** to download a file containing multiple Device Logs to your computer. This also contains any network packet captures that have been run from the *Network Diagnostics - Packet Captures* (page 40) driver page.

To get the TV-UC683T's serial number

If you need the controller's serial number when troubleshooting, the number is on:

- A Module Status report (Modstat) under **Core** (or **Main**) **board hardware**

```
Core board hardware:
Type=123, Model=, manufactured on 06/27/2013 S/N 021362247P
RAM: 512 kBytes; FLASH: 1024 kBytes, type = 3
```

- A QR code, serial number, and MAC address printed on a sticker on the cover
- A laser-etched number and QR code on the inside circuit board.

See *To get a Module Status report* (page 58).

To replace the TV-UC683T's fuse

The TV-UC683T has one fuse.

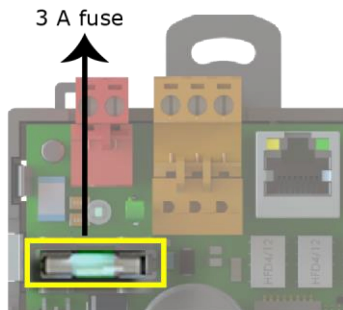

If the TV-UC683T's power  LED is not lit, this could be due to a blown power fuse.

If you suspect a fuse is blown, remove the fuse as described below, and use a multimeter to check it. If the fuse is blown, try to determine why it blew before you replace it. Check the power wiring polarity of the TV-UC683T and any other devices that share the power supply. Use the same polarity for all of them.

You can purchase the 3 A, fast-acting, 5mm x 20mm glass fuse from Littelfuse, mfr part #0235003.HXP.

To replace the fuse:

- 1 Remove the red power connector.
- 2 On both ends of the TV-UC683T, insert a small flathead screwdriver as shown below, and then gently pry up the cover until it is released from the base.

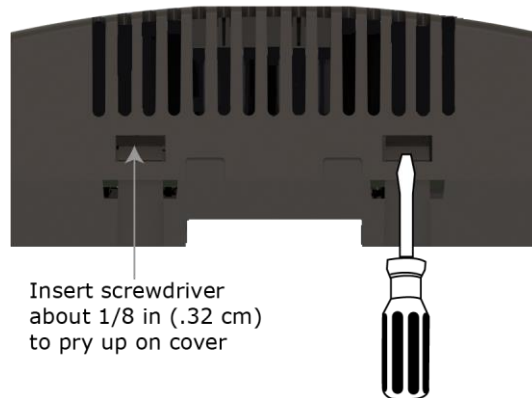

- 3 Remove the cover from the base.
- 4 Remove the blown fuse.
- 5 Snap the new fuse into the fuse holder.
- 6 Replace the TV-UC683T's cover.
- 7 Replace the power connector.
- 8 Verify the  LEDs on the TV-UC683T are lit.

To revert to default settings



WARNING This erases all archived information and user-configuration settings. When recovery is complete, you have to reconfigure all custom settings. You must connect locally to the TV-UC683T and manually reconfigure all the communications and firewall information. We highly recommend that you revert the defaults settings only under the guidance of Carrier Control Systems Support.

To erase volatile memory data and restore factory default configuration settings, use AppLoader to download the appropriate clipping.

See the *AppLoader User Guide* for details.

To take the TV-UC683T out of service

If needed for troubleshooting or start-up, you can prevent the i-Vu® application from communicating with the TV-UC683T by shutting down communication from the TV-UC683T to the i-Vu® application. When **Out of Service**, i-Vu® no longer communicates properties, colors, trends, etc.

- 1 On the i-Vu® navigation tree, select the TV-UC683T.
- 2 On the **Properties** page, check **Out of Service**.
- 3 Click **Accept**.

Compliance

FCC Compliance

This device complies with Part 15 of the FCC Rules. Operation is subject to the following two conditions:

- 1 This device may not cause harmful interference.
- 2 This device must accept any interference received, including interference that may cause undesired operation.



IMPORTANT Any changes or modifications not expressly approved by manufacturer could void the user's authority to operate the equipment.

NOTE This equipment has been tested and found to comply with the limits for a Class B digital device, pursuant to Part 15 of the FCC Rules. These limits are designed to provide reasonable protection against harmful interference when the equipment is operated in a residential installation. This equipment generates, uses, and can radiate radio frequency energy, and if it is not installed and used in accordance with this document, it may cause harmful interference to radio communications. However, there is no guarantee that interference will not occur in a particular installation. If this equipment does cause harmful interference to radio or television reception, which can be determined by turning the equipment off and on, the user is encouraged to try to correct the interference by one or more of the following measures:

- Reorient or relocate the receiving antenna.
- Increase the separation between the equipment and receiver.
- Connect the equipment into an outlet on a circuit different from that to which the receiver is connected.
- Consult the dealer or an experienced radio/TV technician for help.

CE and UKCA Compliance



WARNING This is a Class A product. In a domestic environment, this product may cause radio interference in which case the user may be required to take adequate measures.

Industry Canada Compliance

This Class A digital apparatus complies with Canadian ICES-003.
Cet appareil numérique de la classe A est conforme à la norme NMB-003 du Canada.

BACnet Compliance

Compliance of listed products to requirements of ASHRAE Standard 135 is the responsibility of BACnet International. BTL® is a registered trademark of BACnet International.

Appendix - Module Status field descriptions

Field	Description
ADDRESS BINDING	<p>The controller's:</p> <ul style="list-style-type: none"> • Device Instance • Network number • MAC address <p>See <i>To set up the controller through the Service Port</i> (page 45).</p>
Date/Time	Date and time the Modstat was run
Model Name	Identifies the Product Type
Device Instance	A unique ID assigned to the controller
Driver built	When the driver was built
Downloaded by	When and where the last download was performed
Application Software Version	The application software version that is in the BACnet device.
Data Partition Version	Not applicable to this device.
# PRGs initialized # PRGs running	If applicable, the number of control programs that were downloaded vs. the number that are running. If these numbers are not the same, the controller has a problem such as lack of memory.
Driver version	The name, version, and date of the driver, as well as all the bundles and versions.
Reset Counters:	The number of times each of the following events have occurred since the last time the controller was commanded to clear the reset counters. See NOTE below this table.
Power failures	Interruption of incoming power
Commanded boots	Includes commands issued from the i-Vu® interface such as the zap manual command, plus commands issued during a memory download.
System errors	Error in the controller's firmware or hardware
S/W Watchdog timeouts	Watchdog is firmware that monitors the application firmware for normal operation. If the watchdog firmware detects a problem, it restarts the application firmware.
H/W Watchdog timeouts	H/W Watchdog will restart the controller if it detects a severe problem with the controller's operating system
System status	Gives the current status of the controller's operation. See <i>LEDs</i> (page 55) for all possible conditions.
Network status	Gives the current status of the controller's networks. See <i>LEDs</i> (page 55) for all possible conditions.
System error message history	High-severity errors since the last memory download. Shows the most recent 10 messages. See NOTE below this table.

Field	Description
Warning message history	Low-severity errors and warning messages since the last memory download. Shows the most recent 10 messages. See NOTE below this table.
Information message history	Information-only messages since the last memory download. Shows the most recent 10 messages. See NOTE below this table.
Core and Base board hardware	Gives the following information about the controller's boards: <ul style="list-style-type: none"> Type and board numbers that are used internally by Carrier. The manufacture date and serial number.
Number of BACnet Objects	The number of BACnet objects that were created in the device and the number of those objects that are network visible.
Database Partition	Non-Volatile partition (16 MB maximum) contains data that needs to be preserved through a power cycle and archived to flash such as parameters and trend data. Volatile partition (6 MB maximum) contains data that does not need to be preserved through a power cycle such as status values that are calculated during runtime.
IP Networks - BBMDs	Shows the following information for each active IP network: BBMD Active shows whether the BACnet Broadcast Management Device is currently active (1) or inactive (0). BBMD Entries —the number of entries in the BBMD table (500 maximum). FDT Entries —the number of entries in the Foreign Device Table (500 maximum).
Third party integration points	Shows number of points used.
Modbus integration points	Shows number of points used.
Network Information	The various network addresses for the controller. The Current and Assigned addresses will be the same unless the Enable IP configuration changeover on the BACnet Router Properties page is being implemented.
Statistics and Network Activity	Shows network communication statistics to assist with troubleshooting. See <i>Network Diagnostics - Statistics</i> (page 39) for more information.

NOTE If you want to clear the Reset counters and the three message history fields, click the **Clear Counts/Logs** button on the controller's **Properties** page in the i-Vu® application or in the controller setup **Device** tab.

Document revision history

Important changes to this document are listed below. Minor changes such as typographical or formatting errors are not listed.

Date	Topic	Change description	Code*
5/10/22	CE and UKCA Compliance	Added UKCA Compliance	X-PM-AB-R-BH
	Specifications		
	Addressing the TV-UC683T through the Service port	Added Caution regarding USB connection	X-PM-BM-R-BM
	Inputs	Updated pulse counting note	X-TS-RB-R-RB
	Input values	Updated Pulse to Analog information	
	Specifications	Added Aux 24v+ DC	X-PM-BM-R
1/26/22	Specifications	Updated EU Compliance	X-PM-BM-E
12/3/21	Specifications	Removed reference to not change position of power switch	X-PM-BM-O
	To set the IP address	Removed Sitebuilder reference	C-TS-BB-O
	To communicate through the BACnet Service Port network > Wiring specifications	Changed warning for minimum bend radius	X-TS-BB-O-BM
	Wiring devices to the TV-UC683T Rnet Port	Changed Rnet rate of communication from 115 kbps to 115.2 kbps	X-TS-BB-O
	Specifications	Specified "N.O." binary outputs	
9/16/21	Wiring devices to the TV-UC683T's Act Net port	Rephrased Act Net addresses to list fixed addresses.	X-PM-BM-E
	What is the TruVu™TV-UC683T?		
	Specifications	Changed Real time clock specification to "up to 3 days" from "at least 3 days". Changed EU RoHS compliance code. Rephrased Act Net addresses to list fixed addresses.	X-PM-BM-O

* For internal use only



Carrier ©2022 · Catalog No. 11-808-852-01 · 5/10/2022