

TruVu™ VTBP-E2

Installation and Start-up Guide





Verify that you have the most current version of this document from www.hvacpartners.com, the **Carrier Partner Community** website, or your local Carrier office.

Important changes are listed in **Document revision history** at the end of this document.

©2022 Carrier. All rights reserved.



Contents

What is the TV-VVTBP-E2?	1
Specifications	4
Zone sensors	7
Touchscreen devices	8
Field-supplied hardware	8
Installing the TV-VVTBP-E2 overview	9
Mounting the TV-VVTBP-E2	10
Wiring for power	13
To remove the TV-VVTBP-E2's cover.....	13
To wire for power	14
Addressing the TV-VVTBP-E2 through the Comm/Service ports	15
To set the IP address.....	17
Addressing a network of controllers using the controller setup Local Network tab	18
Method 1: To address when you know the serial numbers	18
Method 2: To address when you do not know the serial numbers	19
Wiring for communications	21
Wiring devices to the TV-VVTBP-E2's Rnet port	22
Wiring devices to the TV-VVTBP-E2's Act Net port	23
Wiring inputs and outputs	24
Inputs.....	24
Outputs.....	24
Wiring specifications.....	25
To wire inputs and outputs.....	25
To adjust input and output properties	28
Input values	29
Output values	30
Resolution values	30
Offset/Polarity values	31
Wiring the DAT sensor to the TV-VVTBP-E2's inputs	32
Wiring specifications.....	32
To wire and mount the DAT sensor.....	32
Wiring field-supplied actuators to the analog output	33
High-torque actuators	33
Linked actuators	34
Find and upload in the I-Vu® interface	36
Using the static pressure sensor	37
To connect the duct tube(s) to the static pressure sensor	37
Start-up	38
Configuring the TV-VVTBP-E2's properties	38
Performing system checkout.....	39
Bypass damper.....	39
Variable frequency drive (VFD)	40
Sequence of operation	41
Duct static pressure control	41
LAT monitoring and limiting.....	41
Equipment fan off detection	42
Supply Air Temperature Alarm	42
Airside linkage.....	42

Air source mode determination.....	43
Adjusting the TV-VVTBP-E2 driver properties.....	44
Driver	44
Device	46
Notification Classes.....	46
Calendars	47
Common Alarms	48
Specific Events	48
Custom Translation Tables.....	49
BACnet Controller Properties	49
BACnet Firewall.....	50
Network Diagnostics - Statistics.....	51
Network Diagnostics - Packet Capture.....	52
Act Net Bus	53
Communication Status	55
Flow Calibration Archive	55
To set up Network Statistic trends.....	55
To set up the controller through the Comm/Service ports	57
ModStat tab.....	57
Device tab	58
Ports tab.....	58
BACnet tab.....	59
Security tab.....	59
Local Network tab.....	59
To communicate through the BACnet/Service port network.....	63
Wiring specifications.....	64
To communicate locally through the Rnet port.....	65
To set up a Local Access connection in the i-Vu® interface	66
Troubleshooting.....	67
LEDs	67
To use the Locator LED	69
To configure custom Prog 1/2 LEDs.....	70
To get a Module Status report	70
Troubleshooting inputs and outputs	71
To get a Device Log	72
To get the TV-VVTBP-E2's serial number	72
To take the TV-VVTBP-E2 out of service	73
To replace the TV-VVTBP-E2's fuse.....	73
To revert to default settings	74
Compliance	75
FCC Compliance.....	75
CE and UKCA Compliance	75
Industry Canada Compliance.....	75
BACnet Compliance.....	75
Appendix A: TV-VVTBP-E2 Points/Properties.....	76
Status.....	76
Unit Configuration.....	76
Maintenance.....	78
Alarms	79
Linkage.....	79
I/O Points.....	80
Appendix B: BACnet points list	81
Appendix C: Module Status field descriptions.....	82



Document revision history84



What is the TV-VVTBP-E2?

The TruVu™ Advanced Application Controller (part no. TV-VVTBP-E2):

- Runs 2 control programs
 - a VVT bypass Product Integrated Control (PIC)
 - an optional programmable Zone Controller II program
- Supports BACnet/IP communications on the 10/100 Ethernet port as a single node in a daisy-chain configuration or as part of a network using a ring topology
- Supports DHCP IP addressing
- Has built-in network diagnostic capture functionality for troubleshooting
- Has network statistics that can be viewed numerically or as trend graphs
- Has a built-in static pressure sensor
- Supports Rnet devices
- Supports Act Net devices
- Works with the i-Vu® v7.0 or later system with the latest cumulative patch
- Provides 4 universal inputs, 3 binary outputs, and 2 analog outputs

The TV-VVTBP-E2, a component of the i-Vu® Control System, maintains supply duct static pressure by regulating airflow and protects the air source from excessive supply air temperature. It has a built-in static pressure sensor and actuator, uses a patented flow control algorithm, and mounts directly on the bypass duct damper actuator shaft.

The TV-VVTBP-E2 PIC control program regulates the supply duct static pressure by controlling one of the following:

- The system's bypass damper
 - The controller's damper actuator provides 45 in/lbs (5 Nm) of torque. If the actuator's torque is insufficient, the TV-VVTBP-E2 can be used to drive an external high-torque actuator.
- The air source supply fan's variable frequency drive (VFD)

The i-Vu® Control System uses linkage to exchange data between the zone terminals and their air source to form a coordinated HVAC system. The system's air source controller, zone controllers, and bypass controller are linked so that their data exchange can be managed by one zone controller configured as the VVT Master.

What is the TV-VTBP-E2?

The following illustration shows the TV-VTBP-E2 in a typical i-Vu® Control System.

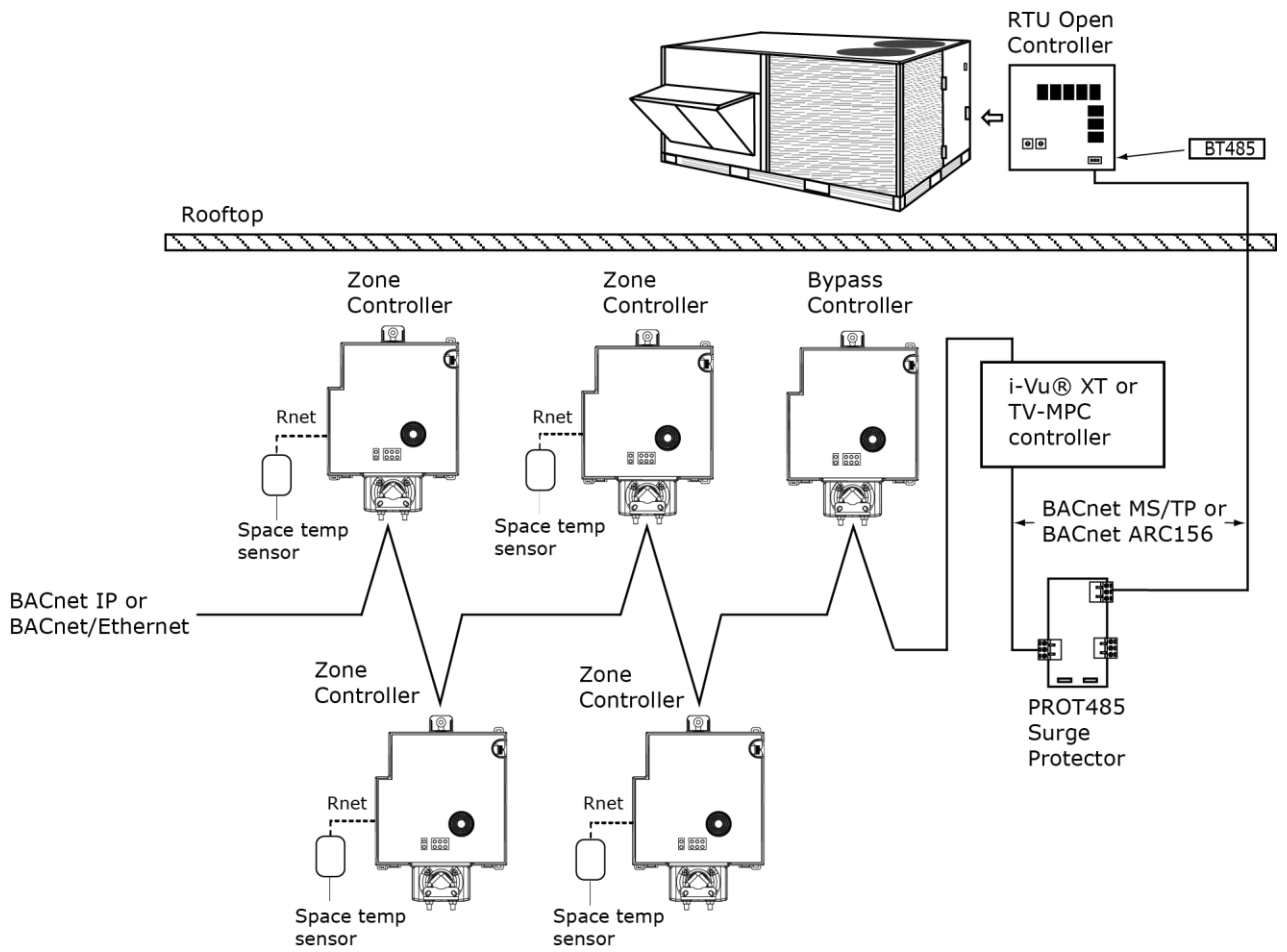



You can use the TV-VTBP-E2's physical communication ports as follows:

Port	Port type	For routing this type of communication...	At...
Eth0	10/100 Mbps Ethernet	BACnet/IP	10 or 100 Mbps
Eth1		BACnet/Ethernet	
S1	High-speed EIA-485 port	BACnet/MSTP	9.6 to 115.2 kbps

What is the TV-VTBP-E2?

The TV-VTBP-E2 also has the following ports:

- Rnet port for connecting ZS sensors, an Equipment Touch, an TruVu™ ET Display, and Wireless Adapter for wireless sensors
- Comm/Service USB ports for connecting locally to controller setup pages, the TruVu™ ET Display, or the Carrier wireless service adapter
- Act Net port supports a combination of up to 5 Act Net addresses. Act Net devices must be addressed as follows:
 - Address **1** is reserved for the built-in actuator
 - Address **2** and **3** are reserved for the VAV Zone II Secondary Duct
 - Address **4** and **5** for i-Vu® Smart Valves



Specifications

Driver	drv_fwex_< version >.driverx
Maximum number of control programs*	2 NOTE You can run 1 VWT bypass Product Integrated Control (PIC) and 1 programmable Zone Controller II program, OR up to 2 Zone Controller II programs.
Maximum number of BACnet objects*	12000
Third-party BACnet integration points	100
NOTE Must be on the BACnet/IP network	
* Depends on available memory.	
Power	24 Vac ±15%, 50–60 Hz, 50 VA 24 Vdc ±10%, 18 W NOTE The above power consumption is for the controller only. Adding devices to the Act Net bus increases total power consumed.
Actuator	Belimo brushless DC motor, torque 45 inch-pounds (5 Nm), runtime 154 seconds
Eth0, Eth1	10/100 BaseT, full duplex, Ethernet ports for BACnet/IP and/or BACnet/Ethernet communication. Under normal operation, network traffic not destined for this controller is repeated to the other Ethernet port. When the controller is powered off, all traffic received on one port is mirrored to the other port.

Rnet port	<ul style="list-style-type: none"> Supports up to 10 wireless and/or ZS sensors, and one Equipment Touch or TruVu™ ET Display Supplies 12 Vdc/260 mA power to the Rnet across its rated temperature range. NOTE Ambient temperature and power source fluctuations exceeding the listed operating ranges may reduce the power supplied by the Rnet port. <p>NOTE If the total power required by the sensors on the Rnet exceeds the power supplied by the Rnet port, use an external power source. The Wireless Adapter, Equipment Touch, or TruVu™ ET Display must be powered by an external power source. See the specifications in each device's Installation and Start-up Guide to determine the power required.</p>
Act Net port	<p>Supports a combination of up to 5 Act Net addresses. Act Net devices must be addressed as follows:</p> <ul style="list-style-type: none"> Address 1 is reserved for the built-in actuator Address 2 and 3 are reserved for the VAV Zone II Secondary Duct Address 4 and 5 for i-Vu® Smart Valves <p>Maximum power available for Act Net devices:</p> <ul style="list-style-type: none"> AC supply - 25 VA (1 A) DC supply - 15W (0.625A) Use an external transformer if your devices exceed the maximum power.
Comm/Service ports	USB 2.0 host ports for setting up the controller and troubleshooting through a local connection to a computer, connecting to the TruVu™ ET Display, or the Carrier wireless service adapter.
Universal inputs	4
	Inputs are configurable in the control program for 0–5 Vdc, 0–10 Vdc, thermistor, dry contact, or pulse counter.
Input resolution	12 bit A/D
Input pulse frequency	10 pulses per second. Minimum pulse width (on or off time) required for each pulse is 50 msec.
Analog outputs	2 analog outputs, 0–10 Vdc Configurable as 12 Vdc pulse width modulated (PWM) control signal.
Binary outputs	One bank of 3 N.O. binary outputs. Each relay contact rated at 3.75 A max. @ 30 Vac/Vdc. Each bank is limited to Class 2 requirements of 100 VA / 4.2 A. Configured normally open. See <i>Output values</i> (page 30).
Output resolution	12 bit D/A
Integral static pressure sensor	Precision differential pressure sensor 0–2 in. H2O, sensitive down to ±0.001 in. H2O. Barbed tapered airflow connections accept 3/16 in. (4.75 mm) I.D. tubing. Allows for readings across the 0–2 in. H2O range, accurate to ±3% of sensor reading at 2 in. H2O.
Controller microprocessor	32-bit ARM Cortex-A8, 600MHz, processor with multi-level cache memory

What is the TV-VTBP-E2?

Memory	<p>4 GBs eMMC Flash memory and 256 MB DDR3 DRAM User data is archived to non-volatile Flash memory when parameters are changed, every 90 seconds, and when the firmware is deliberately restarted.</p> <p>NOTE When you change a parameter, you must wait 30 seconds before turning the power off, in order for the change to be saved.</p>
Real-time clock	Real-time clock keeps track of time in the event of a power failure for up to 3 days.
Protection	<p>Field-replaceable glass fuse (3A fast-acting 5mm x 20mm)</p> <p>The power and network ports comply with the EMC requirements EN50491-5-2.</p>
LED status indicators	<p>See <i>LEDs</i> (page 67) for details.</p> <ul style="list-style-type: none"> • Tricolor Net LED to show network status • Tricolor Sys LED to show controller status • A Tx (Transmit) and Rx (Receive) LED for Port S1 • Tx (Transmit) and Rx (Receive) activity LED and yellow link status LED for the following ports: <ul style="list-style-type: none"> ◦ Ethernet port Eth0 ◦ Ethernet port Eth1 • Output LEDs indicate status of each output. • Prog 1/2 LEDs are customizable. See <i>To configure custom Prog 1/2 LEDs</i> (page 70). • Locator LED to find the controller during commissioning and to assess damper rotation. See <i>To use the Locator LED</i> (page 69).
Environmental operating range	32–122 °F (0–50 °C), 10–95% relative humidity, non-condensing
Physical	Fire-retardant plastic ABS, UL94-5VA
Terminal blocks and connectors	Screw-type terminal blocks. 0.2 in (5.08 mm) pitch connectors
Mounting	Damper shaft/mounting bushing
Overall dimensions	<p>A: 8.39 in. (21.30 cm)</p> <p>B: 5.95 in. (15.11 cm)</p> <p>C: 6.00 in. (15.24 cm)</p> <p>D: 7.52 in. (19.10 cm)</p> <p>Depth: 3.83 in. (9.72 cm)</p>
Weight	1.8 lbs (0.82 kg)

MTBF @ 77°F (25°C)	184,811 hours
BACnet support	Conforms to the BACnet Advanced Application Controller (B-AAC) and B-BBMD Standard Device Profiles as defined in ANSI/ASHRAE Standard 135-2012 (BACnet) Annex L, Protocol Revision 14
Compliance	<p>United States of America: FCC CFR47, Part 15, Subpart B, Class B</p> <p>Canada: Industry Canada Compliant, ICES-003, Class B Contains IC ID: 6713A-STM300U</p> <p>Europe:  Mark, UK:  EN50491-5-2:2009; Part 5-2: EMC requirements for HBES/BACS used in residential, commercial and light industry environment RoHS Compliant: 2015/863/EU REACH Compliant</p>

Zone sensors

You can wire ZS sensors and/or a Wireless Adapter that communicates with wireless sensors to the TV-VVTBP-E2's Rnet port. You can have up to 10 ZS and/or wireless sensors.

NOTES

- A control program can use no more than 5 ZS sensors, so you must use multiple control programs if your Rnet network has more than 5 sensors.
- ZS and wireless sensors can share the Rnet with an Equipment Touch or TruVu™ ET Display.



CAUTION Rnet power

The Rnet port provides 12 Vdc at up to 260 mA. When determining which devices to put on the Rnet, verify that the total current draw of the sensors does not exceed the controller's Rnet power. See the sensor's *Installation and Start-up Guide* to determine the power required.

Touchscreen devices

You can connect the TV-VTBP-E2 to the touchscreen devices using the Rnet port or one of the Comm/Service ports.

Rnet port

You can wire an Equipment Touch or TruVu™ ET Display to the TV-VTBP-E2's Rnet port to view or change the controller's property values, schedule equipment, view trends and alarms, and more, without having to access the system's server. The Rnet port can have one Equipment Touch or TruVu™ ET Display, plus ZS sensors and/or a Wireless Adapter that communicates with wireless sensors.

NOTE These touchscreen devices are not powered by the Rnet port.

- The TruVu™ ET Display requires a 24 Vdc external power source.
- The Equipment Touch requires a 24 Vac external power source.

USB ports

You can connect the TruVu™ ET Display to either of the TV-VTBP-E2's Comm/Service ports to view or change the controller's property values, schedule equipment, view trends and alarms, and more, without having to access the system's server.

NOTES

- These touchscreen devices are not powered by the USB port.
- The TruVu™ ET Display requires a 24 Vdc external power source.



CAUTION A touchscreen device can share a power supply with the Carrier controller if:

- The power source shared by the controller and Equipment Touch is AC power.
- The power source shared by the controller and TruVu™ ET Display is DC power.
- You maintain the same polarity.
- You use the power source only for Carrier controllers.

Field-supplied hardware

Each TV-VTBP-E2 installation requires the following field-supplied components:

- damper
- damper actuator (if high-torque actuator or slaved dampers are required)
- duct air temperature sensor
- power supply—24 Vac, 50VA or 24vdc 18W
- wiring

Installing the TV-VTBP-E2 overview

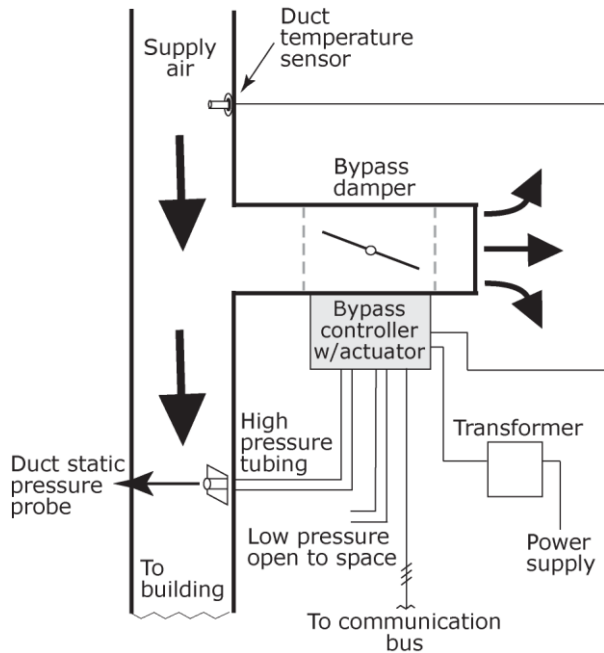

To install the TV-VTBP-E2:

- 1 *Mount the controller* (page 10).
- 2 *Wire the controller for power* (page 13).
- 3 *Set the controller's address* (page 18, page 15).
- 4 *Wire the controller to the BACnet/IP or BACnet/Ethernet network* (page 21).
- 5 *Wire the inputs and outputs* (page 24).

Mounting the TV-VTBP-E2

To mount the TV-VTBP-E2

- 1 Turn the damper shaft to fully close the damper position. Ensure the damper is closed.
- 2 Mount the controller to the bypass duct by sliding the clamp assembly onto the damper shaft.
- 3 Mount and secure an enclosure to cover the TV-VTBP-E2.

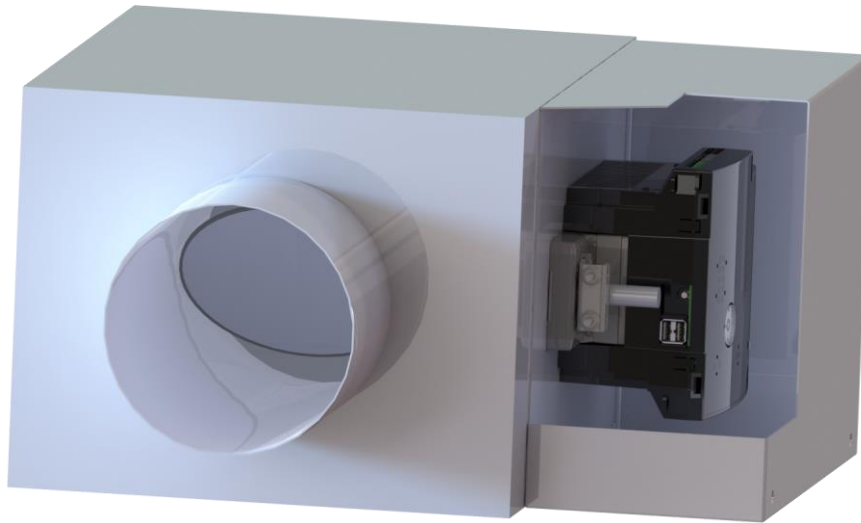

NOTE For service access, allow at least 1 foot (.3 m) of clearance between the front of the enclosure and adjacent surfaces.

- 4 Secure the controller and the actuator by screwing the rear mounting tab into the bypass duct, using the screw that is supplied with the TV-VTBP-E2.

NOTE We recommend that you use the M5 - .75 in. (19 mm), self-tapping screw that is shipped with the TV-VTBP-E2.

CAUTION Center the washer in the mounting screw slot. Secure the TV-VTBP-E2 to allow lateral movement of the damper shaft.

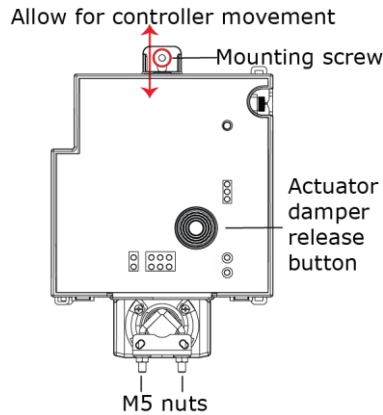

- 5 Hold down the TV-VTBP-E2's actuator release button and rotate the actuator clamp in the same direction that closed the damper. Rotate the clamp until it stops, then rotate it back one notch.
- 6 Release the button.
- 7 Tighten the actuator clamp to the damper shaft by tightening the two M5 nuts.
- 8 Hold down the actuator release button and rotate the damper from fully closed to fully open. If the damper traveled less than 90 degrees, do the following to prevent the damper traveling past fully open:
 - a) Loosen the appropriate stop clamp screw.
 - b) Move the stop clamp until it contacts the edge of the actuator cam.
 - c) Tighten the screw.

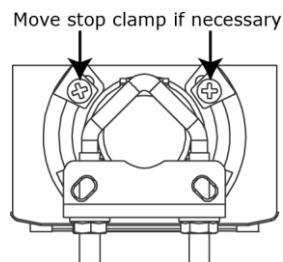

- 9 Hold down the actuator release button, rotate the damper to verify that it opens and closes, then release the button.
- 10 Connect the tube provided to either one of the controller's airflow ports. Using 1/4" poly tubing, connect the other end to a duct static pressure probe (for example, Dwyer Instruments part #A-491, or the equivalent, for a 6" length probe) located in the supply air duct downstream of the bypass damper, but before the first branching of ductwork.
- 11 Leave the remaining airflow port open if using a ducted return, or connect it to room space if using plenum return.

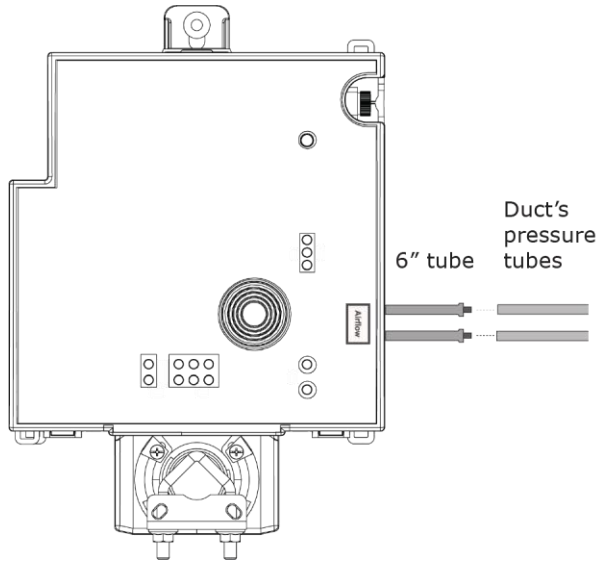

Wiring for power

⚠ WARNING Do not apply line voltage (mains voltage) to the controller's ports and terminals.

⚠ CAUTIONS

- The TV-VTBP-E2 is powered by a Class 2 power source. Take appropriate isolation measures when mounting it in a control panel where non-Class 2 circuits are present.
- Carrier controllers can share a power supply as long as you:
 - Maintain the same polarity.
 - Use the power supply only for Carrier controllers.

To remove the TV-VTBP-E2's cover

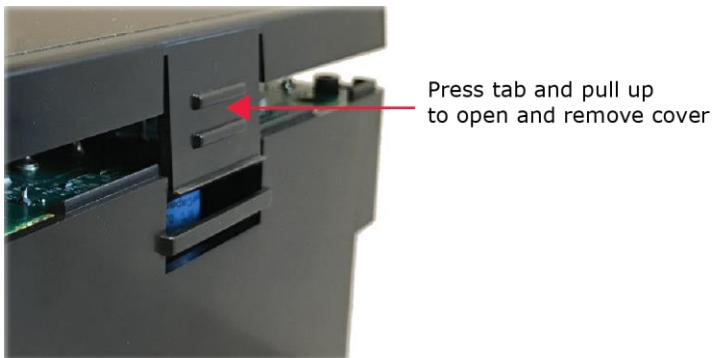

💡 TIP To attach the cover to the base, secure a cable tie through the two cable tie brackets as shown below.

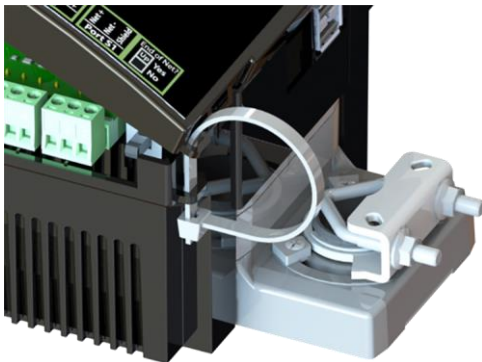

To wire for power

- 1 Remove power from the power supply.
- 2 Remove the TV-VTBP-E2's cover.
- 3 Pull the red screw terminal connector from the controller's power terminals labeled **24V**.
- 4 Connect the power supply's wires to the red screw terminal connector.
- 5 Connect an 18 AWG or larger wire from the power supply's negative (-) terminal to earth ground. This wire must not exceed 12 in. (30.5 cm).
- 6 Apply power to the power supply.
- 7 Measure the voltage at the red screw terminal connector to verify that the voltage is within the operating range of 20.4 to 28.8 Vac or 21.6 to 28.8 Vdc.
- 8 To verify the polarity of the wiring, measure the voltage from the negative terminal of the red screw terminal connector to a nearby ground. The reading should be 0V.
- 9 Insert the red screw terminal connector into the controller's power terminals.
- 10 Verify that the  LED on top of the controller is on.

Addressing the TV-VVTBP-E2 through the Comm/Service ports

You address the TV-VVTBP-E2 on the controller setup pages. The **Local Network** tab allows you to discover all i-Vu® XT or TruVu™ devices on a single network and configure them from that page. See *Addressing a network of controllers using the controller setup Local Network tab* (page 18) and the *Local Network* (page 59) tab.

You can connect the TV-VVTBP-E2 to a computer using a wireless or cable connection to either of the Comm/Service USB ports.

NOTE You cannot access the Service port by plugging an Ethernet cable into Eth0 or Eth1.

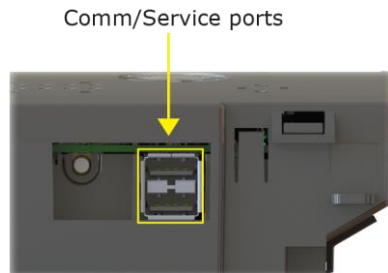

CAUTION The USB local access cable provides a common ground connection between the computer and the controller it connects to. Damage to the controller and possibly the computer's USB port will occur if the controller's input power polarity was not maintained and was also not properly grounded (floating). If you are not sure of the wiring polarity and that the controller was properly grounded, use a USB isolator between the computer and the controller.

To connect the TV-VVTBP-E2 to a computer using the Carrier wireless service adapter.

- 1 Insert the Carrier wireless service adapter (part# USB-W) into either of the controller's USB Comm/Service ports to communicate with a Wi-Fi-compatible computer.
- 2 Open your computer's wireless network display to view your available wireless networks.

NOTE TV-VVTBP-E2 only supports the 5 GHz band and not the 2.4 GHz band.

- 3 Connect to the wireless network using the network SSID and password that are printed on the Carrier wireless service adapter.
- 4 Open a web browser on the computer and navigate to <http://local.access> or <http://169.254.1.1> to see the controller setup pages.

To connect the TV-VTBP-E2 to a computer using a cable.

- 1 Connect a USB Type-A Male to Male USB cable from a computer to either of the controller's Service USB ports, as shown below.

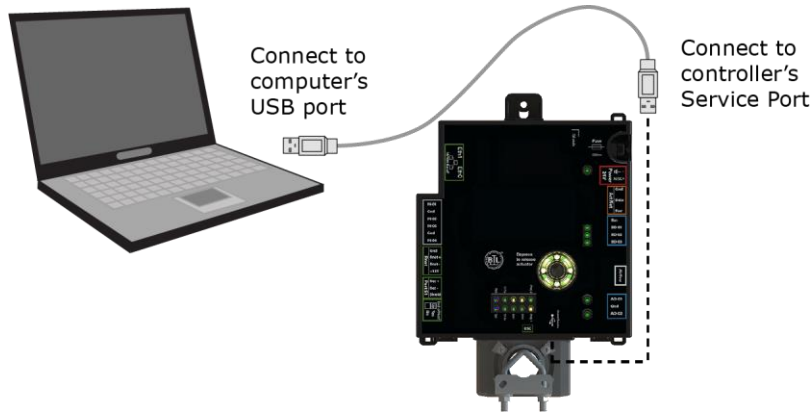

- 2 A new Ethernet connection will appear on your computer.
- 3 If your computer uses a static IP address, use the following settings for the new connection:
 - o Address: 169.254.1.x, where x is 2 to 7
 - o Subnet Mask: 255.255.255.248
 - o Default Gateway: 169.254.1.1If it uses a DHCP address, leave the address as it is.
- 4 Open a web browser on the computer
Navigate to <http://local.access> or <http://169.254.1.1> to see the controller setup pages.

See *To set up the controller through the Comm/Service ports* (page 57) for detailed information.

To set the IP address

You must define the TV-VTBP-E2's IP addressing (IP address, subnet mask, and default gateway) on the controller setup **Ports** tab so that the controller can communicate with the i-Vu Server on the IP network.

Use one of the IP addressing schemes described below with the associated instructions that follow.

Use a...	If...
DHCP IP Address generated by a DHCP server	The IP network uses a DHCP server for IP addressing
Custom Static IP Address from your network administrator	You do not use a DHCP server and the answer to any of the following questions is yes. Will the i-Vu® system: <ul style="list-style-type: none"> • Share a facility's existing IP data network? • Be connected to the Internet? • Have at least one device located on the other side of an IP router? • Be connected to any third-party IP devices?

NOTE Carefully plan your addressing scheme to avoid duplicating addresses. If third-party devices are integrated into the system, make sure your addresses do not conflict with their addresses.

To set a DHCP IP address

- 1 On the controller setup **Modstat** tab, find the controller's **Ethernet MAC address** and write it down.
- 2 On the **Ports** tab under **IP Port**, select **DHCP**.
- 3 Click **Save**.
- 4 Write down the **IP Address**.
- 5 Give the DHCP network administrator the IP address and Ethernet MAC address and ask him to reserve that IP address for the controller so that it always receives the same IP address from the DHCP server.

To set a custom static IP address

- 1 Obtain the IP address, subnet mask, and default gateway address for the controller from the facility network administrator.
- 2 On the controller setup **Ports** tab under **IP Port**, select **Custom Static**.
- 3 Enter the **IP Address**, **Subnet Mask**, and **Default Gateway** addresses that the network administrator gave you.
- 4 Click **Save**.

Addressing a network of controllers using the controller setup Local Network tab

You can use the controller setup **Local Network** tab to discover Carrier i-Vu® XT or TruVu™ devices on a single network. You can configure them and assign addresses to each one using one of the methods described below.

NOTE For this discovery tool to work, the controllers must reside on the same subnet and be downloaded with drv_fwex_107-xx-xxxx or later.

Method 1: To address when you know the serial numbers

- 1 Connect one i-Vu® XT or TruVu™ device on the IP network to either of the Comm/Service ports. For details, see *Addressing the TV-VTBP-E2 through the Comm/Service Ports* (page 15).

NOTE This device is referred to as the "connected controller".

- 2 Browse to the Comm/Service port address (<http://local.access> or <http://169.254.1.1>).
- 3 On the **Ports** tab, set the device's **IP Address**, **Subnet Mask**, and **Default Gateway**.
- 4 On the controller setup **Local Network** tab, verify that the device's address information is displayed at the top of the page.
- 5 On the **Local Network** tab, click the **Clear All** button to erase the **Local Devices** table if there is information in it.
- 6 Click **Discover**. The table finds and lists the first 256 unconfigured devices on the same subnet. The table is sorted by serial number.

NOTE A maximum of 256 i-Vu® XT or TruVu™ controllers can be discovered and displayed in the **Local Devices** table. If you have more than 256 controllers on your network, configure some or all the controllers in the table and click **Clear**. Check **Only Unconfigured** and click **Discover** again. A count appears above the table to report the total number of controllers and the discovered number.

- 7 To configure devices:
 - One at a time - Enter the IP **Address** and **Location** or name (optional) of each device you wish to configure. When you enter the IP address, that device inherits the original device's subnet mask and default gateway.
 - Multiple devices simultaneously - **Select** the devices you want to address, enter the starting IP address in the field under the **Address** heading, and then click **Assign**. The selected devices are automatically assigned sequential IP addresses.

NOTE To change the IP Address, the device's **Mode** must be **Custom Static**.

For more details about discovering and configuring your devices, see **Local Network tab** (page 59).

Method 2: To address when you do not know the serial numbers

You will need physical access to each device so that you can press the DSC button on the side of the TV-VVTBP-E2. This allows you to identify the device on the controller setup **Local Network** page.



- 1 Connect to the Service port of one i-Vu® XT or TruVu™ IP device on the network. For details, see *Addressing the TV-VVTBP-E2 through the Comm/Service ports* (page 15).
- 2 Browse to the Service port address (<http://local.access> or <http://169.254.1.1>).
- 3 On the **Ports** tab, set the device's **IP Address**, **Subnet Mask**, and **Default Gateway**.
NOTE The other devices that you configure inherit this device's subnet mask and default gateway.
- 4 On the **Local Network** tab, click the **Clear All** button to erase any pre-existing data in the **Local Devices** table.
- 5 On the controller you want to address, press the DSC button on the bottom right. When pressed, a row appears in the **Local Devices** table on the **Local Network** tab. The row has a blue dot to indicate which controller has just had the button pressed.
- 6 In the row for the identified controller, enter the **Address** and **Location** (optional).
- 7 Repeat steps 3 and 4 for each controller that you want to address.
- 8 For more details about discovering and configuring your devices, see **Local Network tab** (page 59).

NOTE To physically identify a device that is displayed on the **Local Devices** table, you can click the **Blink** button, which lights up the Locator LED in the actuator release button.

The following are two possible methods you could use to identify and assign a network of controllers' addresses after following steps 1 - 4 above.

- Two technicians can work together if they are communicating throughout the process. The first technician physically travels around the building to each controller, tells his co-worker exactly where he is, and then presses the DSC button. The second technician, who is sitting at a computer connected to the controller, watches for the blue dot to show up on the **Local Devices** table on the **Local Network** tab, where he can enter the appropriate addressing and identifying information.
- One technician alone can address the controllers on a mobile device showing the Local Network page by plugging the Carrier wireless service adapter into a controller's Service port. Then, with the computer, move to each controller within 100 ft. of the adapter. Pressing the DSC button on the controller displays a blue dot in the table where the addressing information can be entered.

Wiring for communications

The TV-VTBP-E2 communicates on the following ports.

Port	Protocol	Port type(s)	Speed(s)
Eth0 Eth1	BACnet/IP BACnet/Ethernet	Ethernet	10 or 100 Mbps
Port S1 ¹	BACnet/MSTP	RS485	9.6 to 115.2 kbps
Comm/Service USB Port ²	USB 2.0	USB	
Rnet Port	See <i>Wiring devices to the TV-VTBP-E2's Rnet port</i> (page 22).		
Act Net Port	See <i>Wiring devices to the TV-VTBP-E2's Act Net port</i> (page 23).		

¹ Default for MS/TP is 76.8 kbps.

² See *To set up the controller through the Comm/Service ports* (page 57).

Wiring devices to the TV-VTBP-E2's Rnet port

You can wire the following devices to the TV-VTBP-E2's Rnet port in a daisy-chain configuration:

- ZS sensors
- Wireless Adapter that communicates with wireless sensors
- Equipment Touch
- TruVu™ ET Display

See the device's *Installation and Start-up Guide* for complete wiring instructions.

NOTES

- ZS sensors, a Wireless Adapter, and an Equipment Touch can share the same Rnet.
- The Rnet communicates at a rate of 115.2 kbps.

Wiring devices to the TV-VTBP-E2's Act Net port

Supports a combination of up to 5 Act Net addresses. Act Net devices must be addressed as follows:

- Address **1** is reserved for the built-in actuator
- Address **2** and **3** are reserved for the VAV Zone II Secondary Duct
- Address **4** and **5** for i-Vu® Smart Valves

Maximum power available for Act Net devices:

- AC supply - 25 VA (1 A)
- DC supply - 15W (0.625A)
- Use an external transformer if your devices exceed the maximum power.

CAUTIONS

- If the power source for the external Act Net devices require a connection to earth ground, you must place it in the same control panel as the TV-VTBP-E2 controller, so that it shares a common earth ground reference, thereby reducing the potential for ground loops.
- A remote Act Net power source, installed near the Act Net devices, should be floating (no local connection to earth ground).

The TV-VTBP-E2 provides an orange, three-pin removable screw terminal connector for the Act Net port.

Be careful to wire the Act Net port terminals on the controller to the matching terminal on the supported device. They may not be in the same order. See example below.

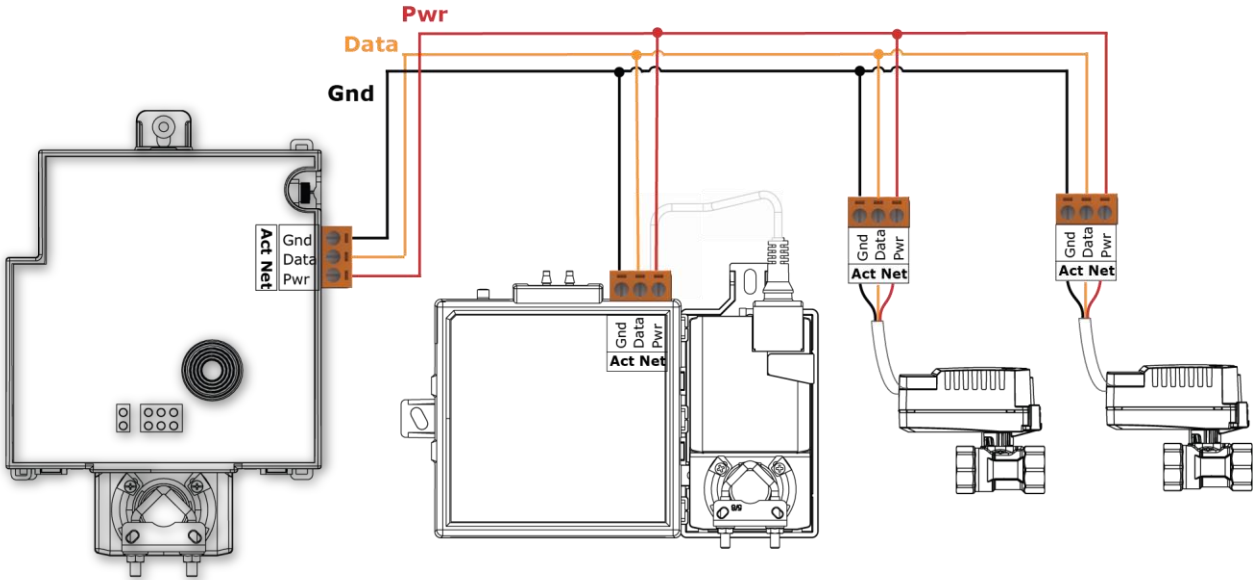

The TV-VTBP-E2 supports Act Net communication to the Act Net devices on a bus with a maximum length of 300 feet (91.44 meters). The bus should be wired with copper conductors of an appropriate size (18 AWG or larger) to compensate for voltage drop and ensure that bus voltage does not drop below 19.2 Vac or 21.6 Vdc.

Wiring inputs and outputs

Inputs

The TV-VTBP-E2 has inputs that accept the following signal types.

Signal Type	Description
Thermistor ¹	Precon Type 2 (10kOhm at 77 °F) Input voltages should be from 0.2 Vdc to 4.0 Vdc for thermistors
Dry contact	The maximum current when the contact is closed is 0.5 mA. The input voltage should be 4.1 V when the contact is open. Maximum closed contact resistance is 1kOhms.
0–5 Vdc 0–10 Vdc	The input impedance of the TV-VTBP-E2 is approximately 120 kOhm when configured as a voltage input.
Pulse counter ²	Pulse counting up to 10 pulses per second. Minimum pulse width (on or off time) required for each pulse is 50 msec.

¹ To use a thermistor not listed above, you can set up a *custom translation table* (page 49) for your sensor in the controller's driver.

² The TV-VTBP-E2 can perform pulse counting for Dry Contact or Binary Input if you assign the input to a Pulse to Analog Input microblock. See To adjust input and output properties.

Outputs

Analog outputs

Analog outputs can be used for 0-10 Vdc devices. Resistance to the ground must be 500 Ohms minimum.

NOTE The device must share the same ground as the controller.

You can configure analog outputs in the Snap application for pulse-width modulated (PWM) control of devices, such as electrically commutated motors. When used in pulse-width mode, the output voltage is 12 Vdc and the frequency is locked at 80 Hz. To enable, use an AO microblock and select **80 Hz PWM** from the **Output Type** drop-down list.

NOTE The PWM output signal is intended to directly control the speed of an ECM-type fan, eliminating the need for an external converter board.

Binary outputs

There is one bank of relays. The bank contains 3 built-in relays with dry contacts that share a common bus input. An external voltage source must be wired to the common Bus connection for the bank of relays.

The relay can be used to switch the voltage provided on its associated bus terminal to an external device or relay. The relay can switch up to 3.75 A, 30 Vac/Vdc. The total power and current that can be switched by a bank of 3 relays cannot exceed the Class 2 limits of 100 VA or 4.2 A.

Wiring specifications

Input wiring

Input	Maximum length	Minimum gauge	Shielding
Thermistor Dry contact	1000 feet (305 meters)	22 AWG	Shielded
0-5 Vdc 0-10 Vdc	1000 feet (305 meters)	26 AWG	Shielded
Pulse counter TLO	1000 feet (305 meters)	22 AWG	Shielded

Output wiring

To size output wiring, consider the following:

- Total loop distance from the controller to the controlled device
 - NOTE** Include the total distance of actual wire. For 2-conductor wires, this is twice the cable length.
- Acceptable voltage drop in the wire from the controller to the controlled device
- Resistance (Ohms) of the chosen wire gauge
- Maximum current (Amps) the controlled device requires to operate

To wire inputs and outputs

 **WARNING** Do not apply line voltage (mains voltage) to the controller's ports and terminals.

The Gnd terminal is shared by the inputs/outputs to the top and bottom of it.

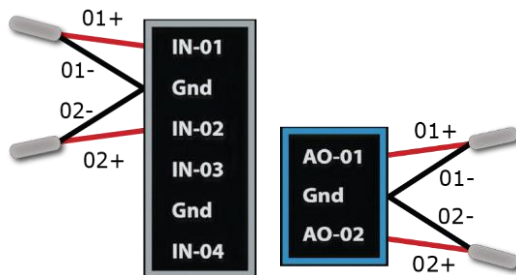

The TV-VTBP-E2 has connections for one bus.

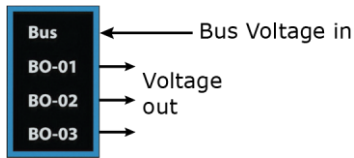

- 1 Verify that the TV-VTBP-E2's power and communications connections work properly.
- 2 Turn **off** the TV-VTBP-E2's power.
- 3 Connect the input wiring to the screw terminals on the TV-VTBP-E2.

NOTE Connect the shield wire to the - terminal with the ground wire. Do not connect the shield wire at the other end of the cable as this will cause a ground loop error.

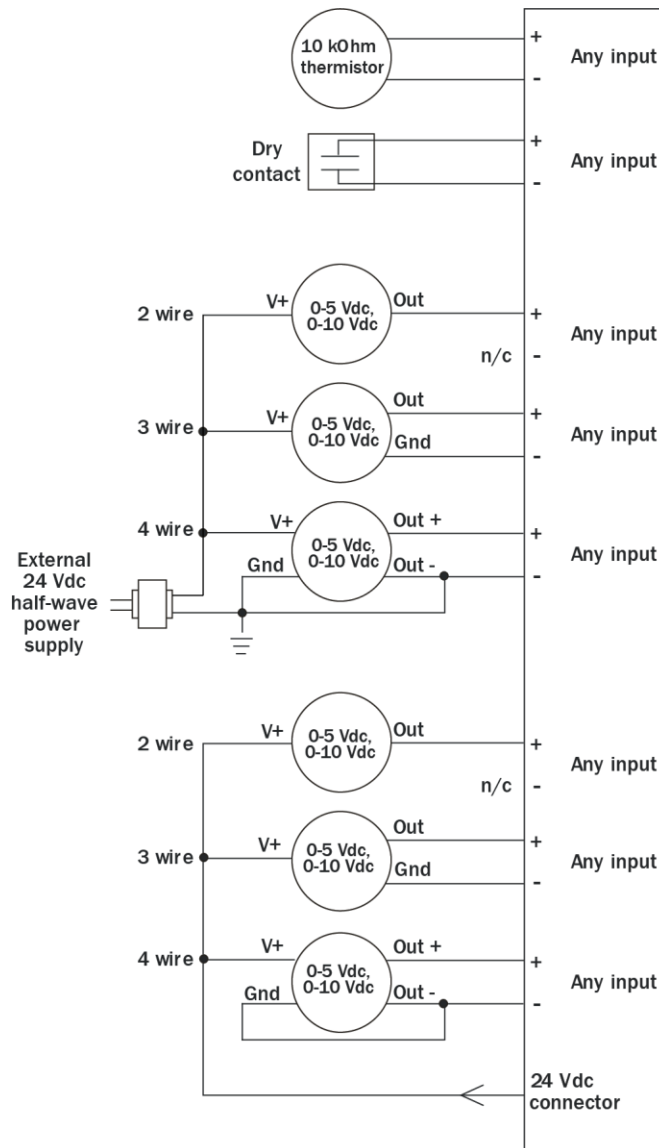

- 4 Connect binary and analog output wiring to the screw terminals on the TV-WTBP-E2 and to the controlled device.
- 5 Connect the ground wire to the AO outputs' terminals.

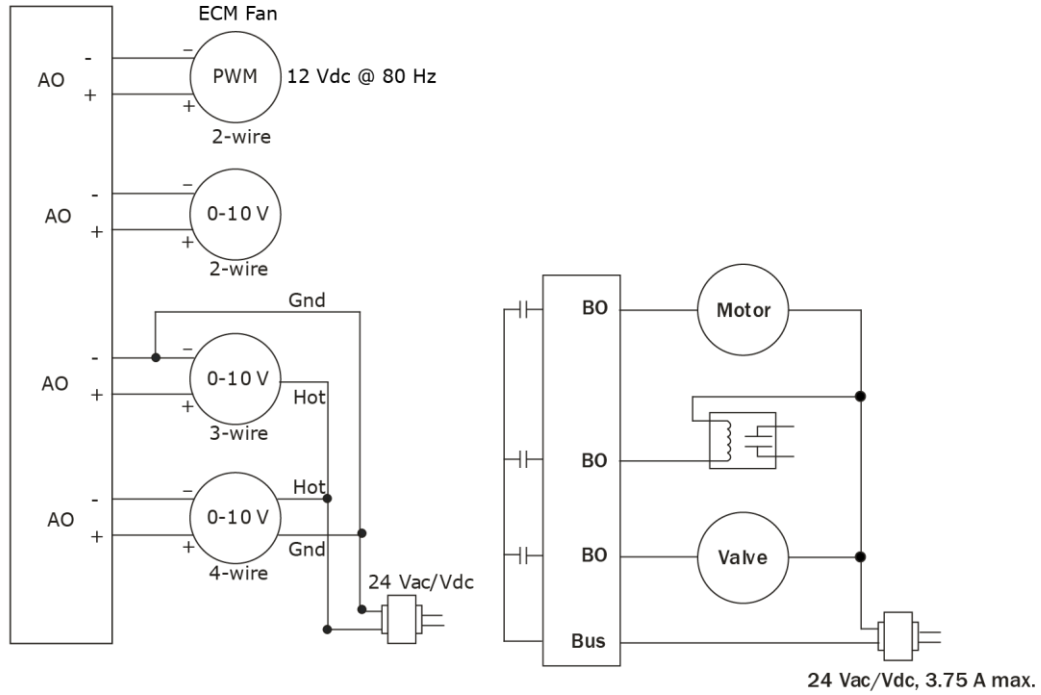

- 6 Turn **on** the TV-WTBP-E2's power.

See *Troubleshooting inputs and outputs* (page 71).

To adjust input and output properties

An input or output must be assigned to its corresponding point in the control program. This is typically done when the control program is created, but you can adjust the settings at the time of installation in the i-Vu® interface.

- 1 In the i-Vu® navigation tree, select the equipment controlled by the TV-VVTBP-E2.
- 2 On the **Properties** page, select the **I/O Points** tab.
- 3 In each point's **Num** field, type the number of the controller's corresponding input or output. For example, if you use **BO-01** on the TV-VVTBP-E2 for the point **Heat Stage 1**, type 1 in the **Num** field for **Heat Stage 1**.

NOTES

- **Exp** (expander number) is **00** for the inputs and outputs located on the TV-VVTBP-E2.
 - Do not assign the same output number to more than one point.
- 4 Enter the appropriate values for each input and output in the remaining columns. See *Input values*, *Output values*, *Resolution values* and *Offset/Polarity values* below.
 - 5 If you have not performed the initial download to the attached controller, you must download now to verify inputs and outputs.
 - 6 To verify each input's operation, force each sensor to a known value, then compare it to the **Value** shown on the **Properties** page on the **I/O Points** tab.
 - 7 To verify each output's operation, lock each output to a known condition on the **I/O Points** tab, then verify that the equipment operates correctly.

See *Troubleshooting inputs and outputs* (page 71).

Input values

Input	I/O Type	Sensor/Actuator Type	Min/Max
Analog (BAI)			
0-5 Vdc	0–5 Volt	Linear Full Range	Engineering values associated with 0 Vdc (Min) and 5 Vdc (Max) ¹
		No Translation	N/A. The input microblock's value will be the raw voltage of the input.
0-10 Vdc	0–10 Volt	Linear Full Range	Engineering values associated with 0 Vdc (Min) and 10 Vdc (Max)
		No Translation	N/A. The input microblock's value will be the raw voltage of the input.
2-10 Vdc	0–10 Volt	Linear w/Offset, 2–10 Volts	Engineering values associated with 2 Vdc (Min) and 10 Vdc (Max)
Thermistor	Thermistor	Select your Thermistor type or set up and select a Non-Linear, Custom Table ²	N/A
Pulse to Analog (BPTA) ³			
Pulse Counter	Dry Contact or Binary Input	N/A	N/A
Binary (BBI)			
Dry Contact	Dry Contact	N/A	N/A
Binary Contact	Binary Contact	N/A	N/A
Special (BI) ⁴			
Binary	Special	Online flow sensor status	N/A

¹ The sensor reads a value and sends a corresponding signal (Volts) to the TV-VVTBP-E2's physical input. The Analog Input microblock uses the Min and Max values to linearly translate the signal into the engineering value used in subsequent control logic.

² You can set up a *custom translation table* (page 49) on the driver's Custom Translation Tables pages in the i-Vu® interface.

³ The control program must have one Pulse to Analog Input microblock for each pulse counting input.

⁴ The special binary input indicates a communication loss to the airflow sensor. You can use this in your control program to select the actuator movement in the case of flow sensor fault. Sensor reconnection is detected automatically and a power cycle is not required. In the microblock popup, under **Hardware Configuration**, set **Expander** to **0**, **Input Number** to **110**, and **I/O Type** to **Special**. To detect a flow sensor fault on the ZASF-A, use **Input Number 111**.

To adjust input and output properties

Output values

Output	I/O Type	Sensor/Actuator Type	Min/Max
Analog (BAO)			
0-10 Vdc	Electrical 0-10 Volt	Linear Full Range	Engineering values associated with 0 Vdc (Min) and 10 Vdc (Max) ¹
		No Translation	N/A. The Analog Output microblock will output the same value that comes in to the microblock.
2-10 Vdc	Electrical 0-10 Volt	Linear w/Offset, 2-10 Volts	Engineering values associated with 2 Vdc (Min) and 10 Vdc (Max) ¹
12 Vdc PWM	PWM 80 Hz	No Translation	0% (Min) and 100% (Max). The Analog Output microblock varies the width of the pulse based on the value that the microblock receives.
Binary (BBO)			
Relay	Relay/Triac Output	N/A	N/A

¹ The Analog Output microblock uses the Min and Max values to linearly translate its incoming value into a physical output signal (Volts) sent from the TV-VVTBP-E2 to a device. For example, set Min to 0 and Max to 100 for an Analog Output microblock that receives a 0 to 100% open signal from a PID microblock and that controls a 0-10 Vdc actuator so that when the PID signal is 100%, the TV-VVTBP-E2 output is 10 Vdc. Similarly, when the PID signal is 50%, the TV-VVTBP-E2 output is 5 Vdc.

Resolution values

Resolution is not particular to a type of input or output, but the driver handles analog and binary inputs and outputs differently. To set these values appropriately, you should understand how the driver uses them.

Resolution	Notes
Analog Input (BAI)	The driver rounds the microblock's present value according to the resolution. EXAMPLE If the calculated present value is 13.789 and you set the Resolution to 0.1, the control program uses 13.8 for any calculations downstream from the microblock.
Analog Output (BAO)	The driver rounds the wire input value to the microblock before performing any scaling calculations. EXAMPLE If the wire input value is 13.789 and you set the Resolution to 0.1, the microblock uses 13.8 for any scaling calculations.

Offset/Polarity values

Offset/Polarity is not particular to a type of input or output, but the driver handles analog and binary inputs and outputs differently. To set these values appropriately, you should understand how the driver uses them.

Offset/Polarity	Notes
Analog Input (BAI)	<p>Offset value (positive or negative) adds a fine adjustment to a sensor reading after all scaling for calibration.</p> <p>EXAMPLE If a sensor reads 74.9°F when the actual measured value is 73.6°F, enter an Offset of -1.3 to calibrate the sensor to the measured value.</p>
Analog Output (BAO)	You can use the Offset value (positive or negative) to calibrate an output, but you generally do not need to. If used, the driver adds the offset value to the wire input value before performing any scaling calculations to determine the TV-VTBP-E2's output.
Binary Input (BBI)	<p>Polarity determines the microblock's present value when no signal is received from the equipment.</p> <p>When no signal is received from the equipment, if Polarity is set to:</p> <p>normal—present value is off reversed—present value is on</p>
Binary Output (BBO)	<p>Polarity determines the TV-VTBP-E2's output based on the control program's signal to the microblock.</p> <p>When the control program's signal to the microblock is on, if Polarity is set to:</p> <p>normal—output is on reversed—output is off</p> <p>NOTE Regardless of Polarity, the output will be off if the TV-VTBP-E2 loses power.</p>

Wiring the DAT sensor to the TV-VVTBP-E2's inputs

You can wire the Duct Air Temperature sensor (Part #33ZCSENDAT) to the TV-VVTBP-E2's inputs.

The TV-VVTBP-E2 must be connected to a Duct Air Temperature (DAT) sensor that monitors the temperature of the air delivered by the air source.

NOTE This document gives instructions for wiring the sensors to the TV-VVTBP-E2. For mounting and wiring the sensor, see the *Carrier Sensors Installation Guide*.

⚠ WARNING Disconnect electrical power to the TV-VVTBP-E2 before wiring it. Failure to follow this warning could cause electrical shock, personal injury, or damage to the controller.

⚠ CAUTION

- Do not run sensor or relay wires in the same conduit or raceway with Class 1 AC or DC service wiring.
- Do not abrade, cut, or nick the outer jacket of the cable.
- Do not pull or draw cable with a force that may harm the physical or electrical properties.
- Avoid splices in any control wiring.

Wiring specifications

Cable from sensor to controller:	If <100 ft (30.5 meters)	22 AWG, unshielded
	If >100 ft (30.5 meters)	22 AWG, shielded
Maximum length:	500 feet (152 meters)	

To wire and mount the DAT sensor

- 1 Wire the sensor to the controller's **IN-01** and **Gnd** terminal. See diagram below.

NOTE Sensor wiring does not have polarity. The wires can be connected to either terminal.
- 2 Using electrical tape, insulate any exposed wire to prevent shorting.
- 3 Connect shield to earth ground (if using shielded wire to extend cable length).

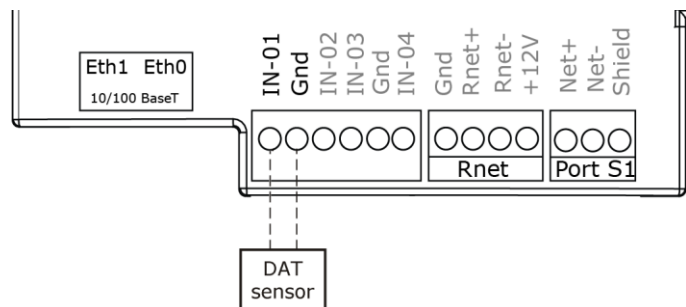

Wiring field-supplied actuators to the analog output

You can wire a high-torque actuator or parallel actuators to the controller's 0–10 Vdc analog output.

NOTE You cannot use the TV-VVTBP-E2's actuator if wiring external actuator(s) to the analog output.

High-torque actuators

You can wire one of the following Belimo actuators to the TV-VVTBP-E2's analog output instead of using the controller's 45 in.-lb (5 Nm) actuator.

NMX24-MFT P-10028	90 in.-lb (10 Nm) actuator with 0–10 Vdc control and 0–10 Vdc feedback
AMX24-MFT P-10028	180 in.-lb (20 Nm) actuator with 0–10 Vdc control and 0–10 Vdc feedback

- 1 Install the actuator according to the manufacturer's instructions.
- 2 Wire the actuator to the controller using the diagram below.

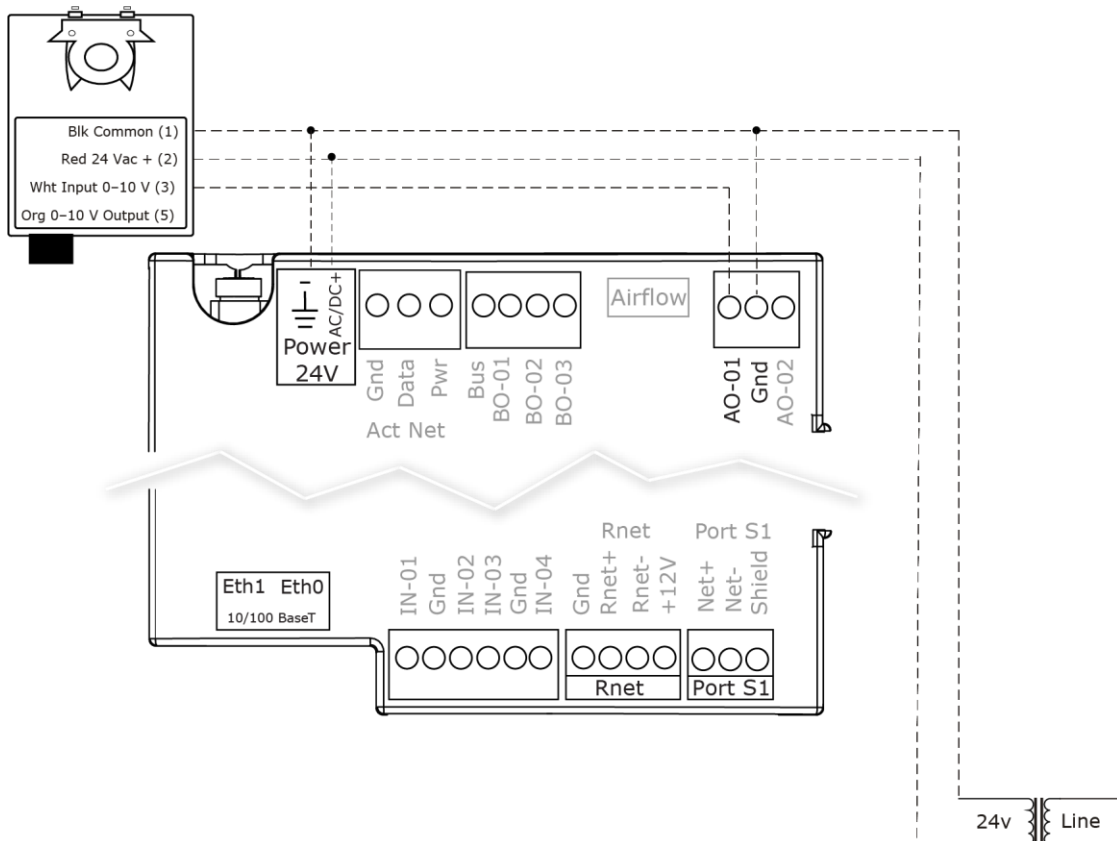

NOTE For proper operation and to prevent damage to the devices, use the same polarity for the actuator's power and the TV-VVTBP-E2's power.

Linked actuators

You can wire up to 4 of the following Belimo actuators to the TV-VTBP-E2's analog output. Link actuators whose travel times and other parameters coincide.

LMX24-MFT P-10028	45 in.-lb (5 Nm) actuator with 0–10 Vdc control
NMX24-MFT P-10028	90 in.-lb (10 Nm) actuator with 0–10 Vdc control
AMX24-MFT P-10028	180 in.-lb (20 Nm) actuator with 0–10 Vdc control

- 1 Install the actuators according to the manufacturer's instructions.
- 2 Wire the actuators to the controller using the diagram below.
- 3 Set the direction rotation switch on each actuator to CW.

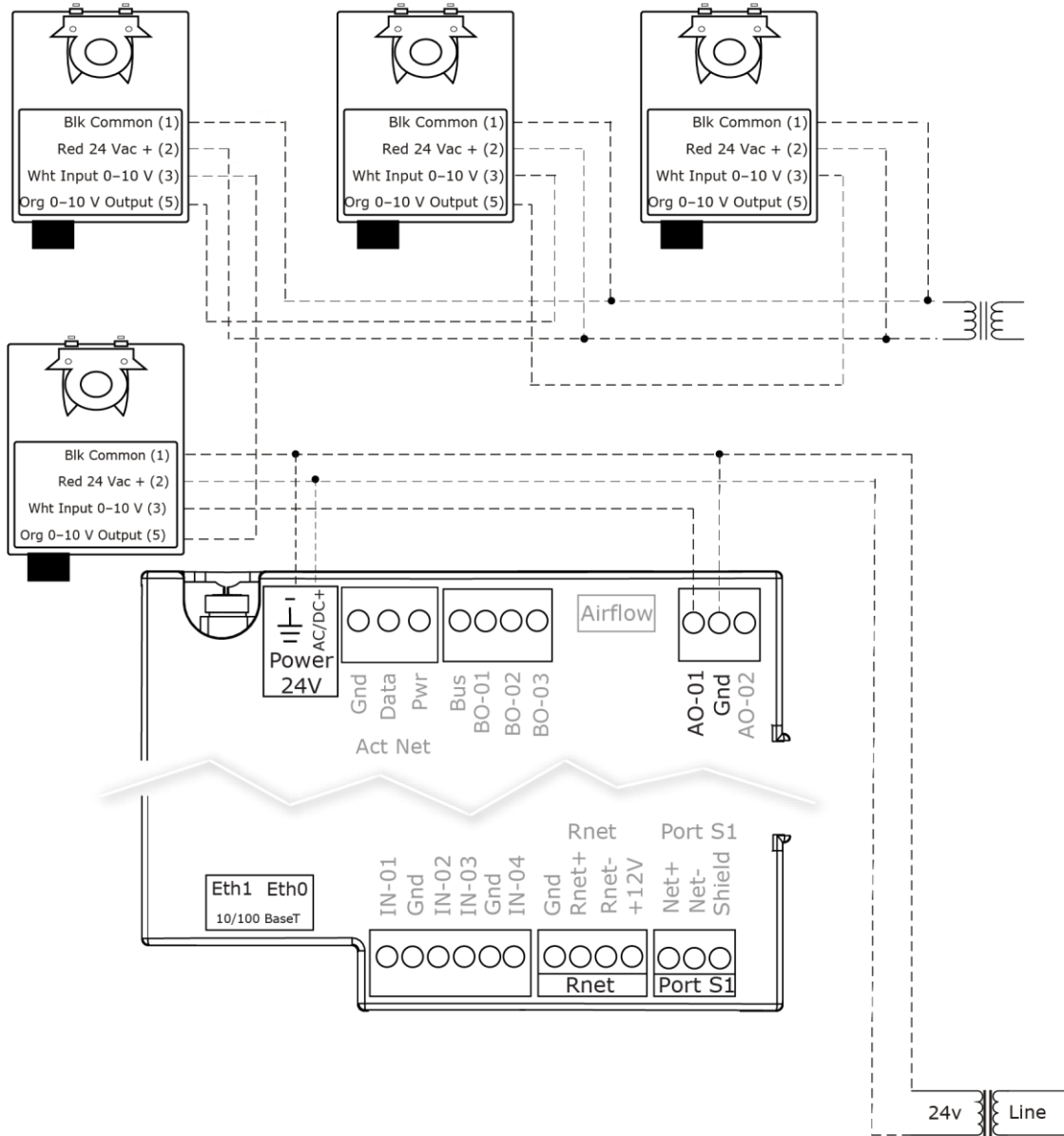

NOTE Maintain polarity if using the same power supply for more than one actuator.

Find and upload in the i-Vu® interface

- 1 In the i-Vu® interface, select the System level in the navigation tree.
- 2 On the **Devices** page > **Manage** tab, click **Find Devices** to discover your routers and their drivers, graphics, and touch files.
- 3 Once routers are found, select one or more routers in the list on the **Manage** tab and click **Upload All Content** to upload to the i-Vu® application. Use **Ctrl+click**, **Shift+click**, or both to select multiple items.
- 4 Click **OK** when you see the message **This will upload all content for the controller. Are you sure you want to do this?** When complete, a check mark under **Status** indicates a successful upload.

NOTES

- If an error message appears, click on the message to view an explanation.
- For details, see the i-Vu® Help.

Using the static pressure sensor

In a single duct system, the TV-VTBP-E2 maintains supply duct static pressure by regulating airflow using the built-in static pressure sensor and internal actuator.

To connect the duct tube(s) to the static pressure sensor

NOTE Tubing should be at least 2 ft. (.61 meters) long for stable airflow measurement. The combined high and low tubing length should not exceed 16.4 ft. (5 meters) in order to ensure accurate measurements.

For a single duct system

- 1 Turn off the TV-VTBP-E2's power.
- 2 Connect the tubes to the TV-VTBP-E2's airflow (pressure) sensor port. Then connect those tubes to the duct's high and low pressure tubes. Avoid sharp bends in the tubing.

NOTE You can connect the duct's high and low pressure tubes to either port. The TV-VTBP-E2 automatically determines the polarity and calculates for positive flow. The **Driver Properties > Flow Calibration Archive** page displays the tubes' polarity.

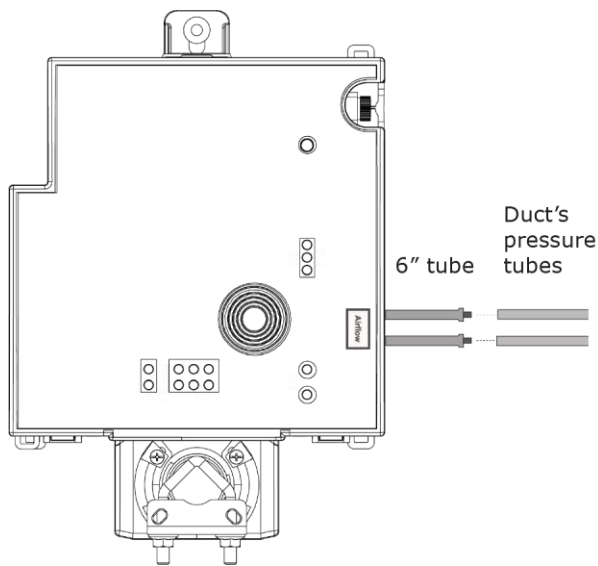

Start-up

Use one of the following interfaces to start up, access information, read sensor values, and test the controller.

This interface...	Provides a...
Field Assistant application - Runs on a laptop that connects to controller's Local Access port ¹	Temporary interface
Equipment Touch device - Connects to controller's Rnet port ²	Temporary or permanent interface
TruVu™ ET Display device - Connects to controller's Rnet port ³	
I-Vu® application Available for BACnet systems only	Permanent interface
System Touch device Available only for BACnet MS/TP systems. Wire to a BACnet MS/TP network connector and a 24 Vac power supply ⁴	Temporary or permanent interface

¹ Requires a USB Link (Part #USB-L).

² See the *Equipment Touch Installation and Setup Guide* for detailed instructions.

³ See the *TruVu™ ET Display (part# EQT2) Installation and Setup Guide* for detailed instructions.

⁴ See the *System Touch Installation and Setup Guide* for detailed instructions.



CAUTION If multiple controllers share power but polarity was not maintained when they were wired, the difference between the controller's ground and the computer's AC power ground could damage the USB Link and the controller. If you are not sure of the wiring polarity, use a USB isolator between the computer and the USB Link. Purchase a USB isolator online from a third-party manufacturer.

Configuring the TV-VTBP-E2's properties

To start up the TV-VTBP-E2, you must configure certain points and properties. *Appendix A* (page 76) is a complete list of all the points and properties, with descriptions, defaults, and ranges. These properties affect the unit operation and/or control. Review and understand the meaning and purpose of each property before changing it.

See *Appendix A* (page 76) for a complete list of the controller's points/properties.

NOTE Engineering units shown in this document in the defaults and ranges are strictly for reference. You must enter an integer only.

Performing system checkout

Bypass damper

- 1 Verify the TV-VVTBP-E2 is securely fastened to the bypass damper shaft and duct work.
- 2 Verify duct air temperature sensor is installed at the inlet of the damper or in the air source supply duct upstream of the bypass damper connection.
- 3 Verify that the single tube from the controller's airflow (pressure) sensor is connected to the duct static pressure probe downstream of the bypass damper. Then verify that the other connector is open when using a ducted return, or connected to room space for plenum return.
- 4 Calibrate damper and pressure sensor:
 - a) Disable the air source heating, cooling, and fan outputs using one of the following methods:
 - Physically disconnect the air source controller's output wiring to the unit.
 - In the i-Vu® or Field Assistant navigation tree, select the RTU Open controller. Go to **Properties > Control Program > Configuration > Service Configuration > Service Test**, then enable **Service Test**. Make sure all other outputs under **Service Test** are disabled.
 - b) Select the Bypass controller in the tree, then go to **Properties > Control Program > Unit Configuration > Bypass Control > Details** tab.
 - c) Click **Damper Full Close**, then verify that the damper is fully closed.
 - d) Click **Damper Full Open**, then verify that the damper is fully open.
 - e) Click **Zero Cal** to close the bypass damper and zero the pressure sensor. When **Done** appears, click **Apply**.
 - f) Enable the air source fan output using one of the following methods:
 - Physically connect the air source controller's fan enable wiring at the unit.
 - In the i-Vu® or Field Assistant tree, select the RTU Open controller. Go to **Properties > Control Program > Configuration > Service Configuration > Service Test**, then enable **Fan Test**. Make sure all other outputs under **Service Test** are disabled.
 - g) Select the Bypass controller in the tree, then go to **Properties > Control Program > Unit Configuration > Bypass Control > Details** tab.
 - h) After the static pressure has stabilized, make sure that **Target Damper Position** and **Duct Static Pressure** are not locked and that **Target Damper Position** is >0% and <100%. You may have to adjust the **Duct Static Pressure Setpoint** slightly to get the damper within this range.
 - i) Using a branch-tee, connect a magnehelic gauge to the **High** tube on the controller's airflow sensor, then measure the static pressure. If the measured static pressure is different from the **Duct Static Pressure** by ± 0.05 in. (± 0.12 kPa), click **Pressure Sensor Cal**, enter the measured value next to the button, then click **Apply**.
 - j) Remove the magnehelic gauge from the **High** tube and reconnect the pressure tubing.
 - k) Click **Automatic Control** to return the bypass to normal control.
 - l) Enable the air source's heating and cooling outputs using one of the following methods:
 - Reconnect the air source controller's output wiring at the unit.
 - In the i-Vu® or Field Assistant tree, select the RTU Open controller. Go to **Properties > Control Program > Configuration > Service Configuration > Service Test**, then disable **Service Test** and **Fan Test**. Make sure all other outputs under **Service Test** are disabled.

Variable frequency drive (VFD)

- 1 Verify that the controller's **AO-01** output wiring is correctly connected to the VFD and that the VFD is configured for a 0-10 Vdc control signal.
- 2 In the i-Vu® or Field Assistant tree, select the Bypass controller. Go to **Properties > Control Program > Unit Configuration**, then verify that **Control Device Type** is set to **VFD**.
- 3 Verify duct air temperature sensor is installed in the air source supply duct.
- 4 Verify that the high pressure tubing from the controller's airflow (pressure) sensor is connected to the duct static pressure probe downstream of the bypass damper. Then verify that the low pressure connector is not blocked.
- 5 Calibrate the VFD and pressure sensor:
 - a) Disable the air source heating, cooling, and fan outputs using one of the following methods:
 - Physically disconnect the air source controller's output wiring to the unit.
 - In the i-Vu® or Field Assistant navigation tree, select the RTU Open controller. Go to **Properties > Control Program > Configuration > Service Configuration > Service Test**, then enable **Service Test**. Make sure all other outputs under **Service Test** are disabled.
 - b) Select the Bypass controller in the tree, then go to **Properties > Control Program > Unit Configuration > Bypass Control > Details** tab.
 - c) Click **Damper Full Open**, then verify the voltage at **AO-01** and **Gnd** is 0 Vdc.
 - d) Click **Damper Full Close**, then verify the voltage at **AO-01** and **Gnd** is 10 Vdc.
 - e) Click **Zero Cal** to zero the pressure sensor. When **Done** appears, click **Apply**.
 - f) Enable the air source fan output using one of the following methods:
 - Physically connect the air source controller's fan enable wiring at the unit.
 - In the i-Vu® or Field Assistant tree, select the RTU Open controller. Go to **Properties > Control Program > Configuration > Service Configuration > Service Test**, then enable **Fan Test**. Make sure all other outputs under **Service Test** are disabled.
 - g) Select the Bypass controller in the tree, then go to **Properties > Control Program > Unit Configuration > Bypass Control > Details** tab.
 - h) After the static pressure has stabilized, make sure that **Target Damper Position** and **Duct Static Pressure** are not locked and that **Target Damper Position** is >0% and <100%. You may have to adjust the **Duct Static Pressure Setpoint** slightly to get the damper within this range.
 - i) Using a branch-tee, connect a magnehelic gauge to the **High** tube on the controller's airflow sensor, then measure the static pressure. If the measured static pressure is different from the **Duct Static Pressure** by ± 0.05 in. (± 0.12 kPa), click **Pressure Sensor Cal**, enter the measured value next to the button, then click **Apply**.
 - j) Remove the magnehelic gauge from the **High** tube and reconnect the pressure tubing.
 - k) Click **Automatic Control** to return the bypass to normal control.
 - l) Enable the air source's heating and cooling outputs using one of the following methods:
 - Reconnect the air source controller's output wiring at the unit.
 - In the i-Vu® or Field Assistant tree, select the RTU Open controller. Go to **Properties > Control Program > Configuration > Service Configuration > Service Test**, then disable **Service Test** and **Fan Test**. Make sure all other outputs under **Service Test** are disabled.

Sequence of operation

The TV-VVTBP-E2 maintains supply duct static pressure under all system operating conditions and can operate as part of a linked VVT system or as a stand-alone controller.

Duct static pressure control

The TV-VVTBP-E2 modulates a bypass damper or VFD to maintain the static pressure in the supply duct of the pressure-dependent VVT system. The TV-VVTBP-E2 has a damper actuator that provides 45 in./lbs (5 Nm) of torque.

You can use the controller's 0–10 Vdc output to:

- Drive a larger actuator if the TV-VVTBP-E2's actuator's torque is insufficient. The actuator must be installed so that 0 volts causes the bypass damper to fully open. See **NOTE** below and High-torque actuator.
- Drive multiple damper actuators from a single bypass controller. See **NOTE** below and Linked actuators.
- Control a VFD

NOTE You cannot use the TV-VVTBP-E2's actuator if external actuator(s) are wired to the analog output.

If linkage is active, normal duct static pressure control is overridden if the linked air source is in either of the following modes:

- Fire shutdown or evacuation mode – The bypass damper will be fully open. If controlling a VFD, the VFD output will be at 0%.
- Pressurization mode – The bypass damper will be fully closed. If controlling a VFD, the VFD output will be at 100%.

LAT monitoring and limiting

To protect the air source from excessive supply air temperature conditions, the TV-VVTBP-E2 monitors the supply air temperature. If the temperature reaches either the **Minimum Cooling SAT** [45 °F (7.2 °C) default] or the **Maximum Heating SAT** [120 °F (48.9 °C) default], the Bypass controls to the **LAT Duct Static Pressure Setpoint** which increases airflow through the air source.

The amount of increase in airflow is related to the square root of the pressure increase. For example, a 25% increase in airflow at 1 in. (.249 kPa) of static pressure would require a 56% increase in duct static pressure [(1 in.H₂O (.249 kPa) * (1.25)²) = 1.56 in. H₂O (.388 kPa)]. The default **LAT Duct Static Pressure Setpoint** of 0.8 in.H₂O (.199 kPa) provides a maximum 25% increase in airflow over the default Duct Static Pressure Setpoint of .5 in.H₂O (.125 kPa). [(0.5 in.H₂O (.125 kPa) * (1.25)²) = .75 [~.8] in.H₂O (.199 kPa)]. When the LAT exceeds the **Maximum Heating SAT** or **Minimum Cooling SAT**, the controller detects and indicates the excessive LAT condition and displays the **Controlling Pressure Setpoint** and the associated **LAT Airflow Increase** (%).

The Bypass does not resume normal control to the Duct Static Pressure Setpoint until the SAT drops 15Δ °F (8.3Δ °C) below the Maximum Heating Sat or rises 7Δ °F (3.9Δ °C) above the Minimum Cooling Setpoint.

If the supply air temperature exceeds the configured limits, a **Supply Air Temperature Alarm** is generated. If Linkage is active, the controller monitors the supply air temperature from the equipment rather than its own temperature input for faster response.

Equipment fan off detection

The TV-VVTBP-E2 continuously monitors its damper's position and the supply duct static pressure. If the pressure drops below 10% of the nominal setpoint and the bypass damper is fully closed (or VFD is commanded to maximum speed), after 1 minute the controller assumes that the equipment fan turned off. The bypass damper then modulates to 65% open and the VFD speed is commanded to 35% (3.5 volts) to facilitate a fan restart. The controller monitors the static pressure to determine when the equipment fan restarts. If it rises above 10% of the nominal pressure setpoint, the controller assumes the fan restarted and controls to maintain the duct static pressure setpoint. If Linkage is active, the air source mode is provided to the TV-VVTBP-E2.

Supply Air Temperature Alarm

The TV-VVTBP-E2 generates an alarm if the supply air temperature remains above the configured **Maximum Heating SAT** or below the configured **Minimum Cooling SAT** for more than 5 minutes.

Airside linkage

When the TV-VVTBP-E2 is part of a linked system, it uses data received through Linkage (equipment SAT and mode) to detect excessive leaving air temperature (LAT) conditions at the equipment and equipment operating mode.

Air source mode determination

Linked air source modes – In a linked system, the air source determines its operating mode and qualifies that mode based on its own SAT. The following modes can be sent by the air source depending on its capability and configuration:

OFF	Air source fan is off. Terminal damper is positioned approximately 70% open to allow for system restart.
WARMUP	Air source fan is on and providing first cycle of heat when changing from unoccupied to occupied. It may also be used as an equipment safety to increase system airflow. The terminal's heating setpoint temporarily increases to the midpoint between the configured occupied heating and occupied cooling setpoints.
HEAT	Air source fan is on and providing heat. The terminal modulates its primary air damper to maintain the current heating setpoint.
FREECOOL	Air source fan is on and providing cooling using only the economizer and usually during an unoccupied period. The terminal modulates its primary air damper to maintain the midpoint between the configured occupied heating and occupied cooling setpoints.
COOL	Air source fan is on and providing cooling. The terminal modulates its primary air damper to maintain the current cooling setpoint.
PRESSURIZATION	Air source supply fan is on usually as a result of a fire-life safety input being active. It may also be used as an equipment safety to increase system airflow. The terminal modulates its primary air damper to provide the configured maximum cooling airflow.
EVACUATION	Evacuation is usually the result of a fire-life safety input at the air source being active. The terminal fully closes its primary air damper and disables its terminal fan, if equipped.
VENT	All terminals treat VENT mode the same as the COOL mode. For VVT terminals, VENT modes allows for an increase in airflow. VVT terminals use the greater of the configured Vent Damper Position or the Minimum Cooling Damper Position as the minimum during the VENT mode.

See the air source's installation manual for more specific operation.

Adjusting the TV-VTBP-E2 driver properties

After you find and upload the TV-VTBP-E2 in the i-Vu® interface, you may want to customize the TV-VTBP-E2's settings for your applications. You can change settings on the **Driver Properties** page.

- 1 In the i-Vu® interface, right-click the TV-VTBP-E2 in the navigation tree and select **Driver Properties**.
- 2 Adjust the driver as desired.

Driver

The **Driver** page provides the following information plus the items described in the table below:

- The date/time of last parameter change or the last time the database was archived
- If control programs, properties, and schedules were successfully stored in memory
- The date/time of last backup and restore
- Undelivered Alarm Status

TouchScreen Control	
TouchScreen Schedule Edit Enable	<p>Check this field to allow a user to edit this controller's schedules from an Equipment Touch or System Touch Schedules screen.</p> <p>NOTE Schedules edited on an Equipment Touch or System Touch are not uploaded to the i-Vu® application. This could result in the controller operating on a schedule that differs from the one you see in the i-Vu® interface.</p>
Controller Clock	
Clock Fall Date and Time	Date and time the controller uses when its real-time clock is invalid.
Time Synch Sensitivity (seconds)	When the controller receives a time sync request, if the difference between the controller's time and the time sync's time is greater than this field's value, the controller's time is immediately changed. If the difference is less than this field's value, the controller's time is slowly adjusted until the time is correct.
Network Microblocks	
BACnet third party integration points capacity, integration points requested, and integration points active	<p>Shows how many third-party BACnet points the TV-VTBP-E2 allows (capacity), how many points are in the control program (requested), and how many are currently active (not disabled in i-Vu®).</p> <p>For example, if the controller allows 400 points, the control program has 350 points, and you disabled 30 points in i-Vu®, you will see: Integration points capacity: 400 Integration points requested: 350 Integration points active: 320</p>
Number of poll retries before Network Input Microblocks Indicate failure	The maximum number of retries after the initial attempt that a Network microblock will attempt to communicate with its target device. If unsuccessful, the point will transition to an idle state for 30 seconds before attempting to communicate again. Change this field only if directed by Technical Support.
Periodic rebinding interval	If a microblock uses a wildcard in its address, this timer determines how often the microblock will attempt to find the nearest instance of its target. For example, if an outside air temperature address uses a wildcard, a VAV application will look for the outside air temperature on the same network segment or on the nearest device containing that object.

BACnet COV Throttling	
Enable COV Throttling	<p>Under normal circumstances, COV Throttling should be enabled to prevent excessive network traffic if an object's COV Increment is set too low. See EXCEPTION below.</p> <p>When enabled, if an object generates excessive COV broadcasts (5 updates in 3 seconds), the driver automatically throttles the broadcasts to 1 per second. Also, if the object's value updates excessively for 30 seconds, an alarm is sent to the i-Vu® application listing <u>all</u> objects that are updating excessively. A Return-to-normal alarm is sent only after <u>all</u> objects have stopped updating excessively.</p> <p>EXCEPTION: In rare circumstances, such as process control, a subscribing object may require COV updates more frequently than once per second. For these situations, clear this checkbox, but make sure that your network can support the increased traffic. You will also need to disable the Excessive COV alarms under the driver's Common Alarms.</p>
Trend Sampling	
Collect a daily midnight sample for all points in this controller that are sampling on COV	For values that change infrequently, select to verify at midnight daily that the point is still able to communicate trend values.
Local Network Configuration	
Allow Local Network Configuration from other devices on the local network for 24 hours	You can unlock a controller for 24 hours to make IP address changes.
Locator LED	
Blink	Click the Blink button to prompt the Locator LED to flash for 15 seconds, allowing you to verify the controller's physical location. After flashing, whenever the actuator moves, the LED rotates in the same direction. LED rotation is automatically disabled after 1 hour and can be re-enabled by pressing the Blink button again.
Debug	
Enable Debug Messages	Enable only if directed by Carrier Control Systems Support.

Device

The **Device** page provides the following information plus the items described in the table below:

- BACnet device object properties for the TV-VVTBP-E2
- The character sets supported by this device for BACnet communication
- The controller clock's time and date

Configuration	
BACnet System Status	The current state of the controller: Operational Download in Progress Download Required Backup in Progress Non-Operational
The following fields refer to all networks over which the TV-VVTBP-E2 communicates.	
APDU Timeout	How many milliseconds the device will wait before resending a message if no response is received.
APDU Segment Timeout	How many milliseconds the device will wait before resending a message segment if no response is received.
Number of APDU Retries	The number of times the device will resend a message.

Notification Classes

A BACnet alarm's Notification Class defines:

- Alarm priority for Alarm, Fault, and Return to Normal states
- Options for BACnet alarm acknowledgment
- Where alarms should be sent (recipients)

Alarms in the i-Vu® application use Notification Class #1. The i-Vu® application is automatically a recipient of these alarms.

Priorities	NOTE BACnet defines the following Network message priorities for Alarms and Events.										
	<table border="1"> <thead> <tr> <th>Priority range</th> <th>Network message priority</th> </tr> </thead> <tbody> <tr> <td>00-63</td> <td>Life Safety</td> </tr> <tr> <td>64-127</td> <td>Critical Equipment</td> </tr> <tr> <td>128-191</td> <td>Urgent</td> </tr> <tr> <td>192-255</td> <td>Normal</td> </tr> </tbody> </table>	Priority range	Network message priority	00-63	Life Safety	64-127	Critical Equipment	128-191	Urgent	192-255	Normal
Priority range	Network message priority										
00-63	Life Safety										
64-127	Critical Equipment										
128-191	Urgent										
192-255	Normal										
Priority of Off-Normal	BACnet priority for Alarms.										
Priority of Fault	BACnet priority for Fault messages.										
Priority of Normal	BACnet priority for Return-to-normal messages.										

Ack Required for Off-Normal, Fault, and Normal Specifies whether alarms associated with this Notification Class require a BACnet Acknowledgment for Off-Normal, Fault, or Normal alarms.



TIP You can require operator acknowledgment for an Alarm or Return-to-normal message (stored in the i-Vu® database). In the i-Vu® interface on the **Alarm > Enable/Disable** tab, change the acknowledgment settings for an alarm source or an alarm category.

Recipient List	
Recipients	The first row in this list is from the i-Vu® application. Do not delete this row. Click Add if you want other BACnet devices to receive alarms associated with this Notification Class. NOTE Additional entries in this table may be lost after a download.
Recipient Description	Name that appears in the Recipients table.
Recipient Type	Use Address (static binding) for either of the following: <ul style="list-style-type: none"> • Third-party BACnet device recipients that do not support dynamic binding • When you want alarms to be broadcast (you must uncheck Issue Confirmed Notifications). This use is rare.
Days and times	The days and times during which the recipient will receive alarms.
Recipient Device Object Identifier	Type the Device Instance from SiteBuilder (or from the network administrator for third-party devices) in the # field.
Process Identifier	Change for third-party devices that use a BACnet Process Identifier other than 1. The i-Vu® application processes alarms for any 32-bit Process Identifier.
Issue Confirmed Notifications	Select to have a device continue sending an alarm message until it receives delivery confirmation from the recipient.
Transitions to Send	Uncheck the types of alarms you do not want the recipient to get.

Calendars

Calendars are provided in the driver for BACnet compatibility only. Instead, use the **Schedules** feature in the i-Vu® interface.

Common Alarms

On these pages, you can enable/disable, change BACnet alarm properties, or set delays for the following BACnet alarms:

Common alarms:

- Duplicate Address
- Control Program
- Controller Halted
- Locked I/O
- Program Stopped
- Excessive COV
- All Programs Stopped

Controller Generated Alarm	
Description	Short message shown on the i-Vu® Alarms page or in an alarm action when this type of alarm is generated.
Events	
Alarm Category and Alarm Template	See <i>Setting up an alarm source in the i-Vu® interface</i> in i-Vu® Help.
Enable	Clear these checkboxes to disable Alarm or Return to normal messages of this type from the TV-VTBP-E2.
Notification Class	In a typical i-Vu® system, the Notification Class is 1; however, if needed, you can associate a different notification class with the alarm. See <i>Notification Classes</i> (page 46) to set up alarm delivery options for a specific Notification Class.

Specific Events

On these pages, you can enable/disable, change BACnet alarm properties, or set delays for the following BACnet alarms:

Specific alarms:

- Flow Control Alarm
- Reheat Valve Alarm

NOTE To set up alarm actions for controller generated alarms, see *Alarms* in i-Vu® Help.

Controller Generated Alarm	
Description	Short message shown on the i-Vu® Alarms page or in an alarm action when this type of alarm is generated.
Events	
Alarm Category and Alarm Template	See <i>Alarms</i> in i-Vu® Help.
Enable	Clear these checkboxes to disable Alarm or Return to normal messages of this type from this controller.
Notification Class	Do not change this field.

Custom Translation Tables

You can set up a translation table that an analog input will use to translate the raw data from a non-linear sensor to the engineering units you want it to provide on the output wire of the Analog Input microblock. In the navigation tree, select **Custom Translation Table #1, #2, or #3**. The **Properties** page has instructions.

For the input to use the translation table, go to the control program's **Properties** page > **I/O Points** tab. Click the analog input in the **Name** column. On the **Details** tab, set **Sensor Type (Scaling Method)** to **Non-Linear, Custom Table #__**.

BACnet Controller Properties

The **BACnet Controller Properties** page provides the following information plus the items described in the table below:

- The TV-VVTBP-E2's Ethernet MAC address
- Whether **Port S1** is being used for MS/TP and is disabled

NOTE The options shown on the page change according to your controller's settings.

MS/TP Configuration on Port S1

Address	For Port S1—A unique address on the MS/TP network.
MS/TP Autobaud	To enable autobaud, select Yes . This device will receive its baud rate from the master device.
MS/TP Baud Rate	Set this to a baud rate that all other devices on the MS/TP network are set to.
Max Masters	To increase MS/TP performance, enter the highest address used on the MS/TP network for a master controller. This number must be less than or equal to 127.
Max Info Frames	This is the maximum number of information messages a controller may transmit before it must pass the token to the next controller. Valid values are 1 to 255.  TIP Set Max Info Frames to a number in the range 20 to 100 so that the router does not become a bottleneck for traffic being routed from a high-speed network to the slower MS/TP network.

End of Network Switch Status

Port S1 End of Network	This displays the state of the End of Net? termination switch for Port S1.
-------------------------------	---

IP Configuration	
Allow setup of IP addressing through an external tool	When this field is enabled, you can set up IP addressing through a tool. IP addressing is typically set up through the Service Port.
Enable IP configuration changeover	<p>Only for custom static IP addressing—Select this field to remotely change the controller's IP Address, Subnet Mask, and Default Gateway Address. Type the new addresses and the UDP Port that your server is using to communicate to all controllers.</p> <p>In the Changeover timeout field, enter:</p> <ul style="list-style-type: none">• A specific length of time for the controller to attempt to communicate with the Next Default Gateway Address. The controller will use the Next setting as soon as the controller can communicate with the Next Default Gateway Address, or when the timeout occurs, whichever comes first.• 0:00 to have the controller use the Next settings as soon as the controller can communicate with the Next Default Gateway Address. <p>See "To remotely change a controller's IP address" in i-Vu® Help for more information on using this feature.</p>

BACnet Firewall

If this IP controller is accessible from the Internet, you can increase security by enabling its BACnet firewall. When enabled, this feature prevents the controller from responding to BACnet messages from unidentified sources and allows communication only with IP addresses that you define. These can be all private IP addresses and/or a list of IP addresses. Follow the instructions in the i-Vu® interface to set up the BACnet firewall.

Network Diagnostics - Statistics

This page shows the network statistics for each of the TV-VVTBP-E2's ports that are in use. This same information is provided in a *Module Status report* (page 70).

Click the **Error Rate Trend** or **Packet Rate Trend** link at the bottom of each section to see the statistics displayed as trend graphs. You can also access these trends by clicking on the driver in the network tree, and then selecting **Trends > Enabled Points >** and the desired trend graph.

Click a port's **Reset** button to set all of the numbers to zero so the counting can start over.

Controller Statistics	
Error Counters	Dropped Packets —Data packets that could not be delivered.
	Route Not Found —Packets that could not be delivered because the requested network does not exist.
	Route Unreachable —These are routed packets whose destination network is either busy or offline.
Controller Sourced Packets	Shows the number of packets initiated by the TV-VVTBP-E2 that are not in response to a request from another device. The numbers in this table will also appear in the appropriate columns in the Network Activity tab.
Eth0/Eth1 Port Statistics	
BACnet/IP Statistics	BACnet/IP Rx Unicast Packets —BACnet/IP packets received from a single BACnet device.
	BACnet/IP Tx Unicast Packets —BACnet/IP packets transmitted to a single BACnet device.
	BACnet/IP Rx Broadcast Packets —BACnet/IP broadcast packets received by the TV-VVTBP-E2.
	BACnet/IP Tx Broadcast Packets —BACnet/IP broadcast packets transmitted by the TV-VVTBP-E2.
	Whitelist Rejections (if <i>BACnet Firewall</i> (page 50) is enabled)—Messages blocked by the BACnet Firewall because the IP address that sent the message was not in the whitelist.
Ethernet Statistics	Ethernet Rx packets —All packets (including non-BACnet packets such as a ping) received by the TV-VVTBP-E2.
	Ethernet Tx packets —All packets (including non-BACnet packets such as a ping) transmitted by the TV-VVTBP-E2.
	Receive Errors (total) —All errors related to received packets such as CRC errors, FIFO errors, frame errors, length errors, missed errors, and overrun errors.
	Transmit Errors (total) —All errors related to transmitted packets such as aborted errors, carrier errors, dropped errors, FIFO errors, heartbeat errors, and window errors.
	Dropped Packets —Packets dropped by the TV-VVTBP-E2's Ethernet interface.
Trends	Error Rate Trend —Shows the total number of errors within the interval time.
	Packet Rate Trend —Shows the total number of packets transmitted and received within the trend sampling interval

Network Diagnostics - Packet Capture

This page allows you to capture network communication on a port and then download the capture file for troubleshooting. Choose one of the following capture options:

- **Start/Stop** - Define the start and stop criteria, and then click **Start** and **Accept** to begin the capture. When the capture stops, the capture file is generated.
NOTE If a Start/Stop capture is running on any other port, the **Get capture file** button will be disabled until all Start/Stop captures have completed.
 - **Start capture:** - When you check **At (mm/dd/yyyy hh:mm AM/PM)**, enter the time and date, and click **Start**, the packet capture begins at the date and time you specified.
NOTE The hours field is validated from 0 to 12, and minute field is validated from 0 to 59.
 - **Continuous** - Click **Start** and **Accept** to begin the capture. Click **Save** to momentarily stop the capture and create the capture file. The capture will automatically resume. Click on the **Start/Stop** option to end the **Continuous** capture.
 - If the port is set up for MS/TP, select an option in the **Capture** section.

To download the capture file

Capture files are Wireshark files that are added to the Device Log Archive .tgz file. Do the following to view the files.

- 1 If you do not have Wireshark installed on your computer, download the latest version from the *Wireshark website* (<http://www.wireshark.org>).
- 2 Run the install program, accepting all defaults. Include WinPcap in the installation.
- 3 On the i-Vu® **Packet Capture** page, click **Get capture file** to download the .tgz file. The message appears "Retrieving the file, this may take a little while". Click **OK**.

NOTE If the size of the .tgz is large, there could be a considerable delay (for example, over 2 minutes) after you click **Get capture file** until your browser begins the download.

- 4 Open the .tgz file. The files are in the **captures** folder.

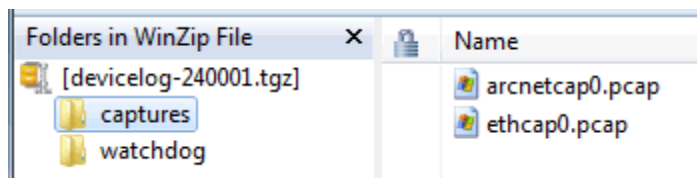

Capture file names are based on the ports.

NOTE Clicking **Get capture file** generates the port's .pcap file. If the port has a .pcap file from a previous capture, that file will be overwritten.

- 5 Extract the .pcap file from the .tgz file.
- 6 Open the .pcap file in Wireshark.

Act Net Bus

Act Net Bus Status

An Act Net device that is physically connected to the TV-VVTBP-E2 is automatically identified and the serial number and current status are displayed on the **Act Net Bus** page.

NOTE You can edit the address and description on this page. Applying changes can take up to 20 seconds to complete.

Act Net Bus Status	This table shows devices connected to the Act Net port. All fields are read-only.	
Device Address	Act Net device address (1 to 5). The same address is used as exp# in the microblock configuration with the input/output number for all Act Net devices set to 1.	
Device Description	This text is editable in the Act Net Bus Configuration table directly below.	
Serial Number	The serial number of the Act Net device. This number is printed on a label on the device.	
Device Status	Displays the current status of the device	
	Possible statuses	Description
	Normal Operation	Successful communication
	No Communication with the device	TV-VVTBP-E2 has lost communication with the Act Net device
	Duplicate Address on the network	More than one device has the same Device Address.
	Unsupported Device Type	Device is not recognized
	Act Net Wiring Error	Loopback error on Act Net bus, possibly caused by wiring problem or hardware failure.
Act Net Bus Configuration	This table shows devices connected to the Act Net port. Most fields are editable.	
Current Address	Bus address of the Act Net device	
Device Description	Edit the name if needed.	
Serial Number	Serial Number of the device corresponds to Current Address in the same row. This field is read-only if the corresponding device is in communication, otherwise becomes editable so that user can enter the serial number manually (can be found as a label on the actuator).	
New Device Address	Select a new bus address from the drop-down list.	

Configuration Status		Once all changes are accepted, after applying changes this fields shows success/fail statuses.
	Possible statuses	Description
	Success	Address selection successful. It may take a few seconds to updates in the status table. Please refresh the page to see the updated status table.
	In Progress	This string appears after accepting the changes and before success/fail messages are appeared. This message may not appear all the time due to data refresh rate.
	Invalid serial number format	A serial number that was entered manually has an invalid format. Correct format example: 01647-20212-250-160
	Device not found	Serial number format is valid, but the device with the number cannot be located.
	Select unused address	If the New Device Address is a duplicate, select an unused address from the drop-down list. To update the table, click Accept after every change.
	Unknown Error	Firmware or bus error.
	Auto addressed device	When a device that does not have an address is found on the bus, an unused address in automatically assigned. You can select a different address in the New Device Address field, if needed.

To resolve duplicate addresses on Act Net bus

When devices display the error **Duplicate Address on the network**, you can use either of the following methods to resolve the problem.

- Method 1: Using the **Act Net Bus Configuration** table
 1. For each duplicate device, enter the **Serial Number**, which you can find on a sticker on the device.
 2. Select a **New Device Address** from the drop-down list.
 3. Click **Accept**.
 4. Verify that there are no longer any **Duplicate Address on the network** errors.

- Method 2: Reinstalling the devices
 1. Remove all duplicate devices from the bus.
 2. Connect one of the removed devices and wait for the **Act Net Bus Status** table to update.
 3. Chose a unique address for the new device and click **Accept**. Wait until the operation is successful.
 4. Repeat the steps 2 and 3 for the remainder of the removed devices.
 5. Verify that there are no longer **Duplicate Address on the network** errors.

Communication Status

Diagnostic Reporting is not applicable to the TV-VVTBP-E2.

Protocol Status shows the status of the protocols currently running on the TV-VVTBP-E2.

Standalone Controller Detection

You can use the fields on this page with a binary input in your control program to detect when the controller does not receive a write request from the selected network within the specified amount of time. The input remains OFF as long as write requests are received, but switches to ON if the controller does not receive a request within the specified time. The binary input must have the Expander number and Input number set to **99** and the I/O Type set to **Special**.

Flow Calibration Archive

The **Flow Calibration Archive** page shows measured flow and sensor readings that were entered in the i-Vu® interface Test and Balance or through the stand-alone Airflow Test and Balance Utility.

Flow Sensor Input Tubes	
Not Calibrated	Flow reading is being generated from default pressure table. Flow sensor always reads absolute.
Calibrated	Flow reading is generated from Airflow Control microblock readings section. Flow sensor indicates negative values if flow is reversed through the VAV box.
Normal / Reversed	Refers to the tube connections. If tubes are switched after calibration process is complete, the calibration process has to re-run to clear settings.

To set up Network Statistic trends

PREREQUISITE To view Network Statistic trends, you must have a i-Vu® v6.5 or later system with the latest cumulative patch.

To view the *Network Statistics* (page 51) as trend graphs, select the controller in i-Vu®'s navigation tree and go to one of the following:

- On the **Driver Properties > Network Diagnostics > Statistics** page, click a **Trend** link at the bottom of each section.
- Click the **Trends** drop-down button, select **Enabled Points** and then the graph you want.

You can define:

- How the graph looks on the trend's **Configure** tab.
- How you want trend samples to be collected on the **Enable/Disable** tab. See table below.

Field	Notes
Sample every _:._ (hh:mm:ss)	(Recommended method) To record the value at a regular time interval, enter hh:mm:ss in this field.
Sample on COV (change of value)	To record the value only when the value changes by at least the amount of the COV Increment , set the Sample every field to 0:00:00 and enter a value in the COV Increment field.
Max samples	Network Statistic trends have a non-configurable maximum trend log buffer size of 1440. NOTE Trending consumes memory in the controller. Click Reset to delete all samples currently stored in the controller.
Stop When Full	Check this field to stop trend sampling when the maximum number of samples is reached.
Enable trend log at specific times only	Collects trend data for the specific period of time you define in the time and date fields.
Enable Trend Historian	Archives trend data to the system database.
Store Trends Now	Writes all trend data in the controller to the system database without having to enable trend historian.
Write to historian every __ trend samples	Writes all trend data in the controller to the system database each time the controller collects the number of samples that you enter in this field. This number must be greater than zero and less than the number entered in the Max samples field. The number of trends specified must be accumulated at least once before the historical trends can be viewed. NOTE Any trends not stored in the historian will be lost if the controller loses power.
Trend samples accumulated since last notification	Shows the number of samples stored in the controller since data was last written to the database.
Last Record Written to Historian	Shows the number of trend samples that were last written to the database.
Keep historical trends for __ days	This is based on the date that the sample was read. Select the first option to use the system default that is defined on the System Options > System Settings > General tab. Select the second option to set a value for this trend only.

To set up the controller through the Comm/Service ports

You can communicate with the TV-VTBP-E2 through a web browser by connecting a computer to one of the Comm/Service USB ports on the controller, using either the Carrier wireless service adapter or a USB cable.

NOTE You cannot access the Service port by plugging an Ethernet cable into Eth0 or Eth1.

Once you are connected to the network, you can:

- Access the controller setup pages
- Address and configure controllers
- View the controller's Module Status report
- View/change controller and network settings. Changes take effect immediately.
- Troubleshoot
- Use BACnet/Service port to access the i-Vu® application or a touchscreen device. See *To communicate through a BACnet/Service port network* (page 57).

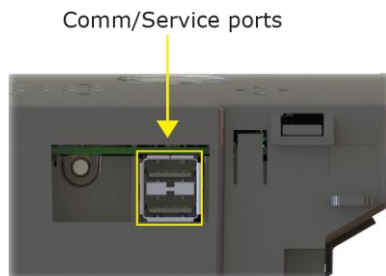

To access the controller setup pages and use the **Local Network** tab, you must first connect to and manually address one TV-VTBP-E2. For instructions on connecting, see *Addressing the TV-VTBP-E2 through the Comm/Service ports* (page 15). Navigate to <http://local.access> or <http://169.254.1.1> to access the pages. Then set up the address on your selected TV-VTBP-E2 on the **Ports** tab (page 58).

NOTE The first time you access the controller in the i-Vu® interface, after you have changed settings through the Service port, be sure to upload the changes to the system database. This will preserve those settings when you download memory or parameters to the controller.

ModStat tab

This tab provides the controller's Module Status report that gives information about the controller and network communication status. See *Appendix - Module Status field descriptions* (page 82).

Device tab

BACnet Object	
Device Instance	<p>Autogenerated—(Default) The Device Instance is automatically set to a number using the IP Address, Subnet information, and the Carrier vendor ID 16.</p> <p>Assigned—Lets you enter a specific number that is unique on the BACnet network.</p>
Device Name	<p>Autogenerated—(Default) The Device Name is automatically set as the word device + the Device Instance. For example, device2423911.</p> <p>Assigned—Lets you enter a specific name that is unique on the BACnet network.</p>
Device Location	You can enter an intuitive location for the device in the i-Vu® interface.
Device Description	You can enter an intuitive description for the device in the i-Vu® interface.
Configuration	
APDU Timeout	How many milliseconds the device will wait before resending a message if no response is received.
APDU Segment Timeout	How many milliseconds the device will wait before resending a message segment if no response is received.
APDU Retries	The number of times the device will resend a message.
Controller Information	
Clear Counts/Logs	Clears Reset counters and the three message history fields from the Module Status.
Data Backup and Restore	
Backup	Displays time of the last backup. Click button to backup the controller's control programs, properties, and schedules.
Restore	Displays time of the last restore. Click button to restore the most recent backup of the controller's control programs, properties, and schedules.

Ports tab

IP Port	
IP Addressing	Select the type of addressing the controller is to use. See <i>Addressing the TV-VTBP-E2</i> (page 15).
Ethernet Port	
Address	A factory assigned Ethernet MAC Address for the Eth0 and Eth1 ports.
Port S1	
End of Network	Indicates status of the controller's End of Net? switch.
Protocol	Change active protocol, if needed.
Active Protocol	Indicates the active protocol on Port S1 Configuration .

BACnet tab

NOTE The TV-VVTBP-E2 can be configured for only one BACnet communication type.

On the **BACnet** tab, you can choose to run **BACnet Over IP** or **BACnet Over Ethernet** on the **Eth0** and **Eth1** ports. If you choose **BACnet Over IP**, you can edit the **BACnet UDP Port**.

Security tab

BACnet Firewall

If your BACnet Firewall configuration in the i-Vu® interface did not include the i-Vu® server IP address, thus blocking communication with the i-Vu® server, you can disable the controller's BACnet Firewall on the controller setup **Security** tab.

NOTE You can enable the BACnet Firewall only in the i-Vu® interface.

Local Network tab

Use the **Local Network** tab to:

- Discover 256 i-Vu® XT or TruVu™ devices on a single network at a time.
- Discover both configured or unconfigured devices on this controller's network.
- See the number of devices discovered and the total number on the network.
- Identify the i-Vu® XT or TruVu™ controller that has had its DSC button pressed.
- Export the **Local Devices** that are present in the table (limited to 256) to a .csv file.
- Set a device's **Mode**, **Address**, and **Location**.
- Assign IP addresses to multiple devices at one time.
- Prompt an LED to flash on a device.

A device that is new from the factory or has not been previously configured with an IP address, can always be configured using the **Local Devices** table. However, once you have assigned a valid IP address, you have up to 24 hours to make any other changes. After 24 hours, the fields are not editable and the device is **Locked**.

You can unlock a device for 24 hours by either pressing the DSC button on the TV-VVTBP-E2 controller or by using the i-Vu® application. In the i-Vu® navigation tree, right-click the TV-VVTBP-E2, select **Driver Properties** and go to **Driver > Settings** tab > **Local Network Configuration**. Check **Allow Local Network Configuration from other devices on the local network for 24 hours** and click **Accept**.

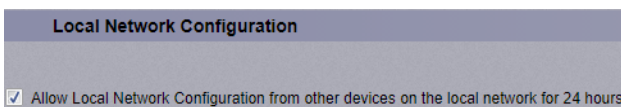

To set up the controller through the Comm/Service ports

To discover devices on a network

- 1 To address a network of devices, you must first select one i-Vu® XT or TruVu™ controller and set the **IP Address**, **Subnet Mask**, and **Default Gateway** on the **Ports** tab.

NOTE This controller is referred to as the connected controller.

- 2 On the **Local Network** tab, at the top of the page, verify that the connected controller's **Mode**, **IP Address**, **Subnet Mask**, and **Default Gateway** are accurate.
- 3 Use the following settings to define the devices that you want to discover in the **Local Devices** table.

Local Devices	
Only Unconfigured	When checked, only discovers devices that do not have an IP address and are linked to the connected controller's network. When unchecked, discovers both configured and unconfigured devices.
Clear All	Erases all information in the table.
Export	Creates .csv file of the data in the table, limited to 256 devices.

- 4 Click **Discover** to populate the table with your i-Vu® XT or TruVu™ devices that are on a single network communicating with the connected i-Vu® XT or TruVu™ controller.

To auto-assign IP addresses to multiple devices at one time

- 1 Follow the above steps to **Discover** devices.
- 2 In the **Select** column, click the checkbox for the devices you want to assign addresses to.
NOTE To change the IP Address, the device's **Mode** must be **Custom Static**.
- 3 Enter the starting IP address under **Address** and click **Assign** to automatically assign sequential IP addresses.

There are different workflows for using the **Local Devices** table to address your devices, depending on the information you have from the installation. See *To address when you know the serial numbers* (page 18) or *To address when you do not know the serial numbers* (page 19).

Local Devices table	
Select	Check to select devices for: <ul style="list-style-type: none"> • Changing the Mode • Resolving a Mismatch • Auto-assigning an IP Address NOTE You cannot select devices with a lock symbol.
MAC	Ethernet MAC address of device
Serial#	The discovered devices are in order by serial number. NOTE To change how the rows are sorted, click a different column heading.

Local Devices table	
Mode	<p>To change the Mode:</p> <ol style="list-style-type: none"> 1 Select the devices you want to change. 2 Select one of the following IP addressing modes: <ul style="list-style-type: none"> • Default IP - Devices with rotary switches that are used when autogenerating the address (if applicable) • Custom Static - A permanent IP addresses which does not change and is usually obtained from the network administrator • NOTE Selecting this automatically sets the device's subnet and default gateway to match the connected controller. • DHCP - Allows the DHCP server to automatically assign an IP address 3 Click the Set button.
Address	<p>Displays the IP address of the device, if assigned. You can edit the address only if the device is set to Custom Static.</p> <p>To auto-assign multiple sequential addresses, select the devices, enter the beginning address, and click Assign.</p>
Location	<p>You can describe the location of the device or any other helpful information.</p>
Mismatch	<p>A Mismatch occurs when the connected controller's mode is set to Custom Static and a discovered device's subnet and default gateway do not match the connected controller. The incorrect addresses are shown with SN for subnet and GW for default gateway.</p> <p>To resolve a mismatch, select the device(s) by clicking the Select checkbox and then clicking the Resolve button. The subnet mask and default gateway addresses of the selected devices change to match the connected controller.</p>
Status	<p>The following are the results of changing Mode, Address, Location, or pressing Blink:</p> <ul style="list-style-type: none"> • Success - Successful operation • No Response - Device is not communicating • Device Locked - Device must be unlocked before you can make any changes using the Local Devices table. You can unlock the TV-VVTBP-E2 by pressing the DSC button on the device or by using the i-Vu® application. (See instructions above.) <p>NOTE The status of a device changes to locked 24 hours after unlocking it.</p> <ul style="list-style-type: none"> • Failure - A conflict between the device and the information entered
Blue dot	<p>A blue dot appears for the most recent device to have the:</p> <ul style="list-style-type: none"> • Blink button clicked in the table • Address or Location entered • DSC button pressed on the device <p>NOTE If the device is not already listed in the table, pressing the DSC button immediately adds it to the table and displays a blue dot.</p> <p> TIP You can build a table of devices in the order that you've pressed the DSC buttons. Clear the table and then press each DSC button in turn. The devices will be listed in the table in the order in which the button was pressed, but only the most recent one will show the blue dot.</p>

To set up the controller through the Comm/Service ports

Local Devices table

Blink

Click the **Blink** button to prompt the Locator LED to flash for 15 seconds, allowing you to verify the controller's physical location. After flashing, whenever the actuator moves, the LED rotates in the same direction. LED rotation is automatically disabled after 1 hour and can be re-enabled by pressing the **Blink** button again.

NOTES

- The blue dot appears when you **Blink** a device.
- You can **Blink** a locked device.

NOTE If a device's IP address is the loopback address (127.0.0.1), it is considered unconfigured and unlocked. The IP address, subnet mask, and default gateway fields are blank in the **Ports** and **Local Network** tabs. You can configure it in the **Local Devices** table.

To communicate through the BACnet/Service port network

You can connect to the Comm/Service Port to access your network through the i-Vu® application.

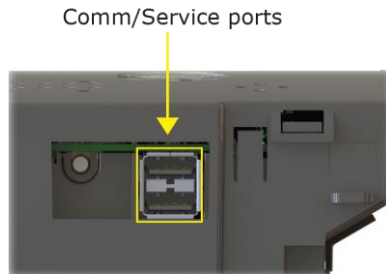

See *Addressing the TV-VVTBP-E2 through the Service port* (page 15) to set up your connection to the web browser if you haven't already.

- 1 Open a web browser on the computer and launch your i-Vu® application.
- 2 In the i-Vu® interface, on the **System Options** tree, select **Connections**.
- 3 On the **Properties** page > **Configure** tab, select **BACnet/IP Service Port Connection** from the drop-down list and click **Add**.
- 4 If needed, enter the **Service Port Network Number** as follows:
 - **0** - the TV-VVTBP-E2 will communicate only with the computer or TruVu™ ET Display
 - **1 to 65534** - the TV-VVTBP-E2's network number for network communication
 - **65535** - searches for an available network number from 65531 to 65534. If any of these numbers are not available, you will have to assign a network number and enter it.
- 5 Click **Apply**.
- 6 On the right of the page, in the **Networks using selected connection** table, click the checkbox next to the network you want to connect to.
- 7 Click the **Start** button. The status changes to **Connected**.

NOTE If an error message appears, make sure the COM port you selected is not in use. For example, PuTTY may be open and holding the port open.
- 8 Click **Accept**.
- 9 Open a web browser on the computer and login to your i-Vu® Pro application.
- 10 In the i-Vu® Pro interface, on the **System Options** tree, select **Connections**.
- 11 On the **Properties** page > **Configure** tab, Select **BACnet/IP Service Port Connection** from the drop-down list and click **Add**.
- 12 If needed, enter the **Service Port Network Number** as follows:
 - **0** - the TV-VVTBP-E2 will communicate only with the computer or TruVu™ ET Display
 - **1 to 65534** - the TV-VVTBP-E2's network number for network communication
 - **65535** - searches for an available network number from 65531 to 65534. If any of these numbers are not available, you will have to assign a network number and enter it.

To communicate through the BACnet/Service port network

- 13 Click **Apply**.
- 14 On the right of the page, in the **Networks using selected connection** table, click the checkbox next to the network you want to connect to.
- 15 Click **Apply**.
- 16 Select the **BACnet/IP Service Port Connection** and click **Start**. The status changes to **Connected**.
- 17 Click **Accept**.
- 18 On the navigation tree, right-click the controller that you are connected to and select **Module Status**. If a Modstat report appears, the i-Vu® application is communicating with the controller.

Wiring specifications

For...	Use...	Maximum Length
Ethernet - not daisy chained	Cat5e or higher Ethernet cable	328 feet (100 meters)
Ethernet - a daisy chain configuration	Cat5e or higher Ethernet cable	164 feet (50 meters)
MS/TP *	22 AWG, low-capacitance, twisted, stranded, shielded copper wire	2000 feet (610 meters)

* See the *MS/TP Networking and Wiring Technical Instructions*.

WARNINGS

- Do not apply line voltage (mains voltage) to the controller's ports and terminals.
- Do not exceed the minimum bend radius of the Cat5e or Cat6e Ethernet cable. Refer to Ethernet cable manufacturer specifications for minimum bend radius.

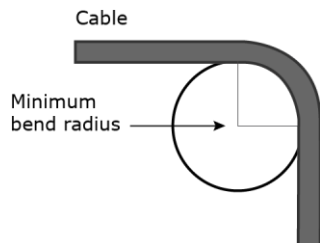

To communicate locally through the Rnet port

You can connect a computer running Field Assistant to the TV-VTBP-E2's **Rnet** port to download or troubleshoot.

PREREQUISITES

- A computer with a USB port
- A USB Link (Part #USB-L)
- For the Field Assistant application to communicate with the controller, the controller must have been downloaded with at least its driver.
- A 3-pin screw terminal connector and 3-wire cable



CAUTIONS

- Maintain polarity when controllers share power.
- Failure to maintain polarity while using the USB Link on a computer that is grounded via its AC adapter may damage the USB Link and the controller.
- If multiple controllers share power but polarity was not maintained when they were wired, the difference between the controller's ground and the computer's AC power ground could damage the USB Link and the controller. If you are not sure of the wiring polarity, use a USB isolator between the computer and the USB Link. Purchase a USB isolator online from a third-party manufacturer. Plug the isolator into your computer's USB port, and then plug the USB Link cable into the isolator.

- 1 The USB Link driver is installed with a v6.5 or later system. Please refer to the Silicon Labs website and search "CP210x USB to UART Bridge VCP Drivers" for the most current device drivers. Install the driver before you connect the USB Link to your computer.
- 2 Connect one end of a piece of 3-wire cable to the 3-pin connector.

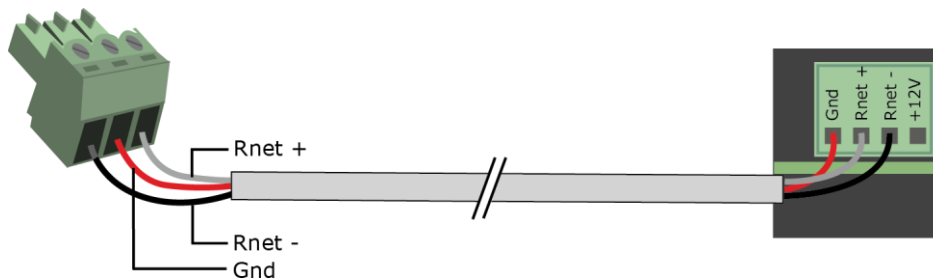

- 3 Connect the other end of the 3-wire cable to the TV-VTBP-E2's **Rnet** port as shown in the drawing above in step 1.
- 4 Connect the 3-pin connector to the portion of the USB link kit shown in the drawing below, then connect the USB connector to the computer.

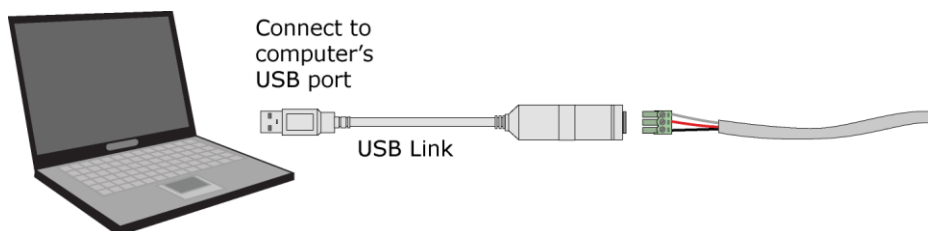

To communicate locally through the Rnet port

To set up a Local Access connection in the i-Vu® interface

For the i-Vu® Pro application to communicate with the **Rnet** port, you must do the following:

- 1 Click , select **System Options > Connections**.
- 2 On the **Configure** tab, click **Add**.
- 3 From the **Type** drop-down list, select **BACnet/Rnet Connection**.
- 4 Optional: Edit the **Description**.
- 5 Type the computer's **Port** number that the USB cable is connected to.

NOTE To find the port number, plug the USB cable into the computer's USB port, then select **Start > Control Panel > System > Device Manager > Ports (Com & LPT)**. The COM port number is beside **Silicon Labs CP210x USB to UART Bridge**.

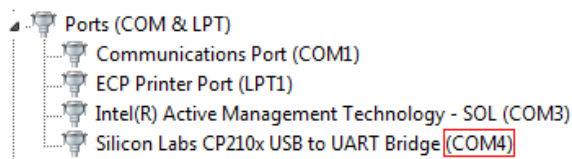

- 6 Set the **Baud** rate to 115200.
- 7 Click **Apply**.
- 8 On the right of the page, in the **Networks using selected connection** table, click the checkbox next to the network you want to connect to.
- 9 Click **Apply**.
- 10 Select **BACnet/Rnet Connection**, then click **Start**.

NOTE If an error message appears, make sure the COM port you selected is not in use. For example, PuTTY may be open and is holding the port open.

- 11 Click **Close**.
- 12 On the navigation tree, select the controller that you are connected to.
- 13 Click , and select **Manual Command**.
- 14 Type `rnet here` in the dialog box, then click **OK**.
- 15 On the **Properties** page, click **Module Status**. If a Modstat report appears, the i-Vu® application is communicating with the controller.

Troubleshooting

If you have problems mounting, wiring, or addressing the TV-VTBP-E2, contact Carrier Control Systems Support.

LEDs

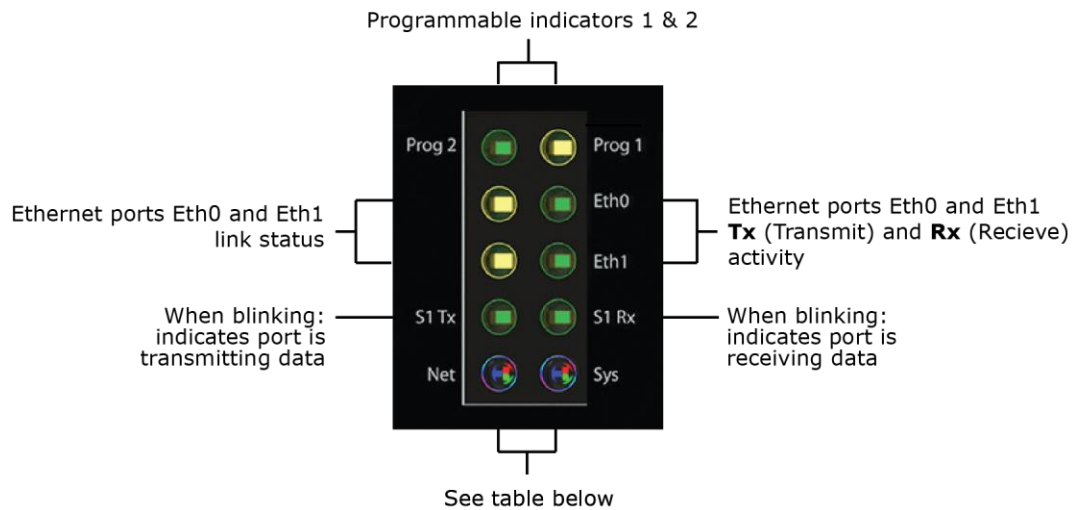

Net (Network Status) Tricolor LED

Color	Pattern	Condition	Message In Module Status	Possible Solutions
Red	On	Ethernet connection problem	No Ethernet Link	<ul style="list-style-type: none"> Connect Ethernet Cable Check other network components
Red	1 blink	One of the following BACnet/IP (Ethernet) DLL reporting issue: <ul style="list-style-type: none"> Unable to create tasks Unable to open socket for BACnet port 	BACnet/IP error	Cycle power
Blue	On	One of the following issues: <ul style="list-style-type: none"> Port communication firmware did not load properly Port communication firmware is not running Invalid protocol selected 	MSTP firmware error	<ul style="list-style-type: none"> Change protocol using USB Service Port Cycle power

Color	Pattern	Condition	Message in Module Status	Possible Solutions
Blue	1 blink	Invalid address selected for protocol	Invalid address selection for MSTP	Change MAC address to unique address using USB Service Port
Blue	2 blink	Controller has same MAC address as another connected device	Duplicate address on MSTP	Change MAC address to a unique value using USB Service Port to valid address
Blue	3 blink	Controller is the only device on the network	No other devices detected on MSTP	<ul style="list-style-type: none"> Check that network cable is connected properly Check that baud rate is correct
Blue	4 blink	Excessive errors detected over 3 second period	Excessive communication errors on MSTP	<ul style="list-style-type: none"> Check that network cable is connected properly Check that baud rate is correct
Green	On	All enabled networks are functioning properly	No errors	No action required
Magenta		Operating system changes are downloading WARNING This process could take several minutes. Do NOT power off the controller during the download.	N/A	No action required

Sys (System Status) Tricolor LED

Color	Pattern	Condition	Message in Module Status	Possible Solution
Red	2 blink	Restarting after an abnormal exit	Auto restart delay due to system error on startup	After 5 minute delay has expired, if condition occurs again then cycle power
Red	4 blink	Firmware image is corrupt	Firmware error	Download driver again
Red	Fast blink	Firmware error has caused the firmware to exit and restart	Fatal error detected	No action required
Green	1 blink	No errors	Operational	No action required
Green	2 blink	Download of driver is in progress	Download in progress	No action required
Green	3 blink	BACnet Device ID is not set	Download required	Download the controller
Green	Fast blink	Installation of recently downloaded driver is occurring	N/A	No action required

Color	Pattern	Condition	Message in Module Status	Possible Solution
Blue	On	Controller is starting up	N/A	No action required
Blue	Slow blink	Linux (operating system) is starting up	N/A	No action required
Blue	Fast blink	Linux is running but it could not start the firmware application	N/A	Download driver
Magenta		Operating system changes are downloading WARNING This process could take several minutes. Do NOT power off the controller during the download.	N/A	No action required

To use the Locator LED

<p>The Locator LED turns on when you:</p> <ul style="list-style-type: none"> power on the controller change the driver Click the Blink button 		<p>Click the Blink button to prompt the Locator LED to flash for 15 seconds, allowing you to verify the controller's physical location. After flashing, whenever the actuator moves, the LED rotates in the same direction. LED rotation is automatically disabled after 1 hour and can be re-enabled by pressing the Blink button again.</p> <p>The Blink button is in the:</p> <ul style="list-style-type: none"> controller setup Local Network tab > Local Devices table i-Vu® interface on the Driver page. In the Test & Balance tool on the Test and Balance tab.
---	---	---

To configure custom Prog 1/2 LEDs

You can customize the **Prog 1** and/or **Prog 2** LED for site-specific purposes by configuring the BACnet Analog Output (BAO) microblock.

Open your control program in the Snap interface, select the AO microblock for each LED, and use the following settings:

Status/Attribute	Microblock type	Expander number : Channel number	I/O type	Description
LED 1	BAO	0:61	Special	<ul style="list-style-type: none"> • ≤ 0 Normal • > 15 On <p>The number of blinks equals the Present Value.</p> <p>The pulse pattern repeats after a 2-second delay</p> <p>LED will blink the number of times given in the BAO with ON pulse 0.5 seconds and OFF pulse 0.5 seconds.</p>
LED 2	BAO	0:62	Special	<ul style="list-style-type: none"> • ≤ 0 Normal • > 15 On <p>The number of blinks equals the Present Value.</p> <p>The pulse pattern repeats after a 2-second delay</p> <p>LED will blink the number of times given in the BAO with ON pulse 0.5 seconds and OFF pulse 0.5 seconds.</p>

To get a Module Status report

A Module Status report provides information about the controller and verifies proper network communication with the controller. You can get this report:

- In the i-Vu® application—Right-click the controller on the navigation tree, then select **Module Status**.
- In the Field Assistant application—Right-click the controller in the navigation tree and select **Module Status**.
- On the controller setup **ModStat** tab—See *To set up the controller through the Service Port* (page 57).

See *Module Status field descriptions* (page 82) in the Appendix.

Troubleshooting inputs and outputs

The i-Vu® interface shows if you have I/O errors resulting from a misconfigured microblock.

To check for errors:

- 1 In the i-Vu® navigation tree, select the equipment controlled by the TV-VTBP-E2.
- 2 On the **Properties** page, select the **I/O Points** tab.
- 3 Click the **Name** of any input or output whose name is red (indicates an error) to open its dialog box.

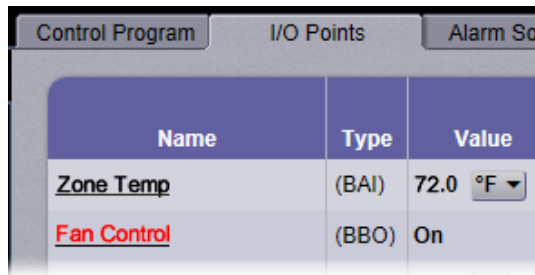

- 4 On the **Details** tab, scroll down to see the **Reliability** field under **BACnet Configuration**.

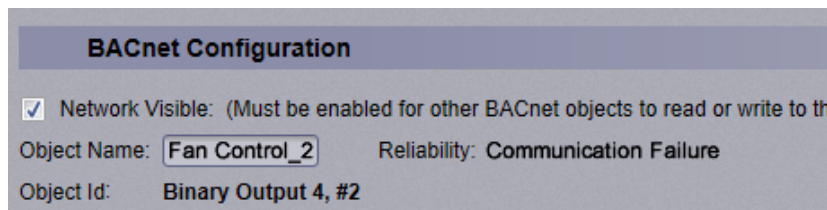

- 5 Anything other than **No Fault Detected** indicates an error. See the table below to determine the error and possible actions to take.

Reliability description	Possible error	Verify that...
Configuration Error	<ul style="list-style-type: none"> • The microblock's I/O Type and Sensor/Actuator Type are not compatible. • The output's DIP switch setting does not match the connected device. • Invalid expander address or I/O number. 	<ul style="list-style-type: none"> • The I/O Type and Sensor/Actuator Type combination is valid for the I/O number and microblock type. • The DIP switch setting is appropriate for the output and microblock type. • The expander is present and functional at the address shown in the i-Vu® interface and that I/O number is valid.
Over Range	<ul style="list-style-type: none"> • Input exceeds the Min/Max limits. 	<ul style="list-style-type: none"> • The input is within the Min/Max limits.
No Sensor	<ul style="list-style-type: none"> • No device is attached to the output. 	<ul style="list-style-type: none"> • The device is present and functioning.
Shorted Loop	<ul style="list-style-type: none"> • Internal voltage feedback does not correspond with commanded value. 	<ul style="list-style-type: none"> • The load on the output is within the valid range. • A voltage/current source has not been connected to an output.

Reliability description	Possible error	Verify that...
Open Loop	<ul style="list-style-type: none"> Internal current feedback does not correspond with commanded value. 	<ul style="list-style-type: none"> The load on the output is within the valid range. A voltage/current source has not been connected to an output.
Unreliable Other	<ul style="list-style-type: none"> Feedback does not correspond with commanded value (for example, the output relay is not in commanded state). 	<ul style="list-style-type: none"> Device may be faulty. Contact Carrier Control Systems Support.

To get a Device Log

If Carrier Control Systems Support instructs you to get the controller's Device Log containing diagnostic information for troubleshooting:

- 1 Select the TV-VTBP-E2 in the i-Vu® navigation tree.
- 2 On the **Properties** page, click **Device Log**.

NOTE You can click **Device Log Archive** to download a file containing multiple Device Logs to your computer. This also contains any network packet captures that have been run from the *Network Diagnostics - Packet Captures* (page 52) driver page.

To get the TV-VTBP-E2's serial number

If you need the controller's serial number when troubleshooting, the number is on:

- A Module Status report (Modstat) under **Core** (or **Main**) **board hardware**

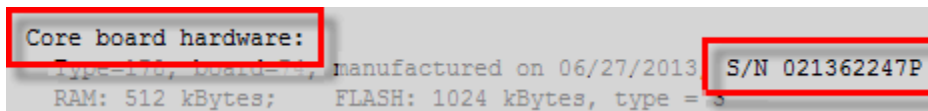

- A QR code, serial number, and MAC address printed on a sticker on the cover
- A laser-etched number and QR code on the inside circuit board.

See *To get a Module Status report* (page 70).

To take the TV-VVTBP-E2 out of service

If needed for troubleshooting or start-up, you can prevent the i-Vu® application from communicating with the TV-VVTBP-E2 by shutting down communication from the TV-VVTBP-E2 to the i-Vu® application. When **Out of Service**, i-Vu® no longer communicates properties, colors, trends, etc.

- 1 On the i-Vu® navigation tree, select the TV-VVTBP-E2.
- 2 On the **Properties** page, check **Out of Service**.
- 3 Click **Accept**.

To replace the TV-VVTBP-E2's fuse

The TV-VVTBP-E2 has one fuse. If the TV-VVTBP-E2's power  LED is not lit, this could be due to a blown power fuse.

If you suspect a fuse is blown, remove the fuse as described below, and use a multimeter to check it. If the fuse is blown, try to determine why it blew before you replace it. Check the power wiring polarity of the TV-VVTBP-E2 and any other devices that share the power supply. Use the same polarity for all of them.

You can purchase the 3 A, fast-acting, 5mm x 20mm glass fuse from Littelfuse, mfr part #0235003.HXP.

To replace the fuse:

- 1 Remove the cover to remove the red power connector.
- 2 Press a small flathead screwdriver into the fuse slot, press inward, and turn the screw ¼ turn counter-clockwise. This springs the fuse holder slightly away from the controller.

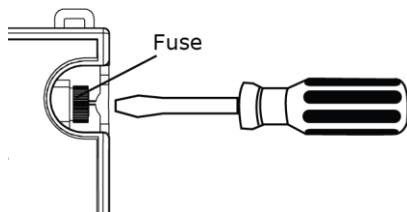

- 3 Remove the fuse holder.
- 4 Remove the blown fuse from the fuse holder.
- 5 Insert the new fuse into the fuse holder.
- 6 Place the fuse holder back into the TV-VVTBP-E2 and turn it ¼ turn clockwise.
- 7 Replace the power connector and cover.
- 8 Verify the  LEDs on the TV-VVTBP-E2 are lit.

To revert to default settings



WARNING This erases all archived information and user-configuration settings. When recovery is complete, you have to reconfigure all custom settings. You must connect locally to the TV-VVTBP-E2 and manually reconfigure all the communications and firewall information. We highly recommend that you revert the defaults settings only under the guidance of Carrier Control Systems Support.

To erase volatile memory data and restore factory default configuration settings, use AppLoader to download the appropriate clipping.

See the *AppLoader User Guide* for details.

Compliance

FCC Compliance

This device complies with Part 15 of the FCC Rules. Operation is subject to the following two conditions:

- 1 This device may not cause harmful interference.
- 2 This device must accept any interference received, including interference that may cause undesired operation.

NOTE This equipment has been tested and found to comply with the limits for a Class A digital device, pursuant to Part 15 of the FCC Rules. These limits are designed to provide reasonable protection against harmful interference when the equipment is operated in a commercial environment. This equipment generates, uses, and can radiate radio frequency energy, and if it is not installed and used in accordance with this document, it may cause harmful interference to radio communications. Operation of this equipment in a residential area is likely to cause harmful interference, in which case the user will be required to correct the interference at his own expense.



CAUTION Any modifications made to this device that are not approved by Carrier will void the authority granted to the user by the FCC to operate this equipment.

CE and UKCA Compliance



WARNING This is a Class B product. In a light industrial environment, this product may cause radio interference in which case the user may be required to take adequate measures.

Industry Canada Compliance

This Class A digital apparatus complies with Canadian ICES-003.
Cet appareil numérique de la classe A est conforme à la norme NMB-003 du Canada.

BACnet Compliance

Compliance of listed products to requirements of ASHRAE Standard 135 is the responsibility of BACnet International. BTL® is a registered trademark of BACnet International.

Appendix A: TV-VTBP-E2 Points/Properties

NOTE Engineering units shown in this document in the defaults and ranges are strictly for reference. You must enter an integer only.

Status

Navigation: i-Vu® / Field Assistant: **Properties > Control Program > Status**

Point Name/Description	Range
Static Pressure - Prime Variable – The current supply duct static pressure. This value is shown on the default area graphic in i-Vu or Field Assistant.	R: 0 to 2.0 in. H ₂ O (0 to .498 kPa)
Supply Air Temperature – If Airside Linkage Status is Active , this is the air source's current supply air temperature. If Airside Linkage Status is Not Active , this value is from the local SAT sensor.	R: -56 to 245 °F (-48.9 to 118.3 °C)
Damper Position – If Control Device Type is Actuator , this is the current open damper position.	R: 0 to 100%
VFD output – If Control Device Type is VFD , this is the current VFD speed capacity.	R: 0 to 100%
LAT Control – The status of LAT Limit duct static pressure override control of the bypass.	R: On/Off
LAT Airflow Increase – If LAT Control is On , this is the percent of increase in supply airflow that the overriding LAT Duct Static Pressure Setpoint will provide above the normal Controlling Pressure Setpoint .	R: 0 to 100%

Unit Configuration

Navigation: i-Vu® / Field Assistant: **Properties > Control Program > Unit Configuration**

Point Name/Description	Default/Range
Control Device Type – The device the controller uses to control static pressure.	D: Actuator R: Actuator/VFD drive
Power Fall Restart Delay – How long the controller delays normal operation after the power is restored.	D: 60 seconds R: 0 to 600 secs
Automatic Deadband Adjustment – If using an actuator, set to Enable to automatically adjust the damper for full travel to correctly scale the damper position. If using a VFD drive, set to Disable.	D: Enable R: Enable/Disable

Point Name/Description	Default/Range
Maximum Heating SAT – The value that the SAT must exceed to cause the static pressure setpoint to be set to the LAT Duct Static Pressure Setpoint . This is also the Supply Air Temperature Alarm 's high limit.	D: 120°F (48.9°C) R: 40 to 180°F (4.4 to 82.2°C)
Minimum Cooling SAT – The minimum low limit value that the SAT must exceed to cause the static pressure setpoint to be set to the LAT Duct Static Pressure Setpoint. This is also the Supply Air Temperature Alarm 's low limit.	D: 45°F (7.2°C) R: 40 to 180°F (4.4 to 82.2°C)
Pressure Control Deadband – The amount that is added to and subtracted from the bypass controlling setpoint (Duct Static Pressure Setpoint or LAT Duct Static Pressure Setpoint). When the static pressure is within the controlling setpoint +/- this value, the output to the actuator or VFD drive maintains at its current position. When the static pressure is greater than the controlling setpoint +/- this value, the output modulates accordingly. CAUTION If this value is too low, the damper may oscillate to maintain the static pressure. This could cause the actuator to fail prematurely.	D: .05 in H ₂ O (.012 kPa) R: 0 to 2.0 in. H ₂ O (0 to .498 kPa)
Bypass Control	
Direction Clockwise – Set this field to the damper's position when it rotates clockwise. (Only in the i-Vu@/Field Assistant applications)	D: Close R: Open/Close
Duct Static Pressure Setpoint – The normal static pressure setpoint the controller will maintain.	D: .5 in. H ₂ O (.125 kPa) R: .1 to 2.0 in. H ₂ O (.025 to .498 kPa)
LAT Duct Static Pressure Setpoint – The static pressure setpoint that the controller will maintain if the SAT exceeds the Maximum Heating SAT or Minimum Cooling SAT value. To disable this function, set this value less than or equal to the Duct Static Pressure Setpoint .	D: .8 in. H ₂ O (.199 kPa) R: .1 to 2.0 in. H ₂ O (.025 to .498 kPa)
Locks –  CAUTION Overriding these values may damage equipment or ductwork. Duct Static Pressure – Allows you to override the static pressure sensor input for testing and troubleshooting.	R: 0 to 2.0 in. H ₂ O (0 to .498 kPa)
Target damper position – Allows you to override the normal control of the damper/VFD for the purpose of testing and troubleshooting.	R: 0 to 100%

Point Name/Description	Default/Range
<p>Test and Balance</p> <p>Zero Cal – Closes the bypass damper and waits for the air source to go to the Off mode before zeroing out the static pressure sensor. This does not occur if the static pressure is > .05 in. H₂O (.0125 kPa) .</p> <p>Pressure Sensor Cal – Allows you to calibrate the pressure sensor after the Zero Cal has been performed. To enter a value here, neither the damper nor the pressure sensor can be locked, the bypass cannot be in LAT mode and the damper position must be >0% and <100%. The value entered will be the actual static pressure measured with an accurate static pressure measuring device.</p> <p>Damper Full Open – Overrides the damper to its full open position.</p> <p>Automatic Control – Returns the damper to its normal control routines. This must be activated when you finish using any of the other Test and Balance commands.</p> <p>Damper Full Close – Overrides the damper to its full closed position.</p>	
Local Sensor Calibration	
Supply Air Temperature – Displays the current supply air temperature.	R: -56 to 245 °F (-48.9 to 118.3 °C)
Supply Air Temp Calibration – A calibration offset value to allow the supply air temperature sensor to be adjusted to match a calibrated standard measuring the temperature in the same location.	R: -20 to 20Δ °F (-11.1 to 11.1Δ °C)

Maintenance

Navigation: i-Vu® / Field Assistant: **Properties > Control Program > Maintenance**

Point Name/Description	Range
Static Pressure – The current supply duct static pressure.	R: 0 to 2.0 in. H ₂ O (0 to .498 kPa)
Controlling Pressure Setpoint – The active static pressure setpoint that the bypass controls to.	R: .1 to 2.0 in. H ₂ O (.025 to .498 kPa)
Maximum Duct Pressure Setpoint – The Pressure Control Deadband that is added to the active static pressure setpoint.	R: 0 to 2.0 in. H ₂ O (0 to .498 kPa)
Minimum Duct Pressure Setpoint – The Pressure Control Deadband that is subtracted from the active static pressure setpoint.	R: 0 to 2.0 in. H ₂ O (0 to .498 kPa)

Alarms

Navigation: i-Vu® / Field Assistant: **Properties > Control Program > Alarms**

Point Name/Description	Range
Supply Air Temperature Alarm – Indicates if the supply air temperature exceeds the high temperature alarm limit or drops below the low temperature alarm limit.	R: Normal/Alarm
Airside Linkage Alarm – Indicates that it lost Linkage communications with the air source.	R: Normal/Alarm

Linkage

Navigation: i-Vu® / Field Assistant: **Properties > Control Program > Linkage**

Point Name/Description	Range
Air Linkage Status – If Active , the controller is part of a linked system. If Not Active , the controller is operating as a stand-alone device.	R: Active/Not Active
Air Source Mode – If Airside Linkage Status is Active , this is the current mode of the linked air source. If Airside Linkage Status is Not Active , this is the mode of the air source as determined by the zone controller's SAT sensor.	R: Off Warmup Heat Cool Freecool Pressure Evac Vent
Air Source Supply Air Temp – Shows the air source's SAT when Airside Linkage Status is Active . If Airside Linkage Status is Not Active , the controller's local DAT sensor value is displayed.	R: -56 to 245 °F (-48.9 to 118.3 °C)

I/O Points

Navigation: i-Vu® / Field Assistant: **Properties > I/O Points**

Point Name/Description	Range
Pressure Input – The current duct static pressure of the controller's integrated airflow sensor.	R: 0 to 2.0 in. H ₂ O (0 to .498 kPa)
SAT Sensor – The current duct air temperature sensor that is physically connected to the controller.	R: -56 to 245 °F (-48.9 to 118.3 °C)
AO Output – The current voltage on the controller's AO-01 output terminal.	R: 0 to 10 Vdc

Appendix B: BACnet points list

				BACnet	
Point Name	Point Access	Units	Default Value	BACnet Point Name	BACnet Object ID
Controlling Pressure Setpoint	R	in H2O		sys_press_stpt	AV:1015
Damper Position	R	%		dpr_pos	AV:1013
LAT Airflow Increase	R	%		lat_airflow_inc	AV:5002
Air Source Supply Air Temp	R	°F		link_sat	AV:2608
Maximum Duct Pressure Setpoint	R	in H2O		max_press_stpt	AV:5003
Maximum Heating SAT	R/W	°F	120	sat_ht_max	AV:83004
Minimum Cooling SAT	R/W	°F	45	sat_cl_min	AV:83003
Power Fail Restart Delay	R/W	sec	60	start_delay	AV:9007
Pressure Control Deadband	R/W	in H2O	0.05	press_hysteresis	AV:3016
Static Pressure - Prime Variable	R	in H2O		static_press	AV:1016
Supply Air Temperature	R	°F		sa_temp	AV:1008
VFD output	R	%		vfd_output	AV:1014
Airside Linkage Status	R	0=Not Active 1=Active		a_link_status	BV:2601
Automatic Deadband Adjustment	R/W	0=Disable 1=Enable	Active (1)	auto_adjust	BV:99003
Control Device Type	R/W	0=Actuator 1=VFD	Inactive (0)	ctrl_type	BV:99002
LAT Control	R	0=Off 1=Active		lat_control	BV:1013
Air Source Mode	R	1=Off 2=Warmup 3=Heat 4=Cool 5=Freecool 6=Pressure 7=Evac 8=Vent		link_ahu_mode	MSV:2005
Airside Linkage Alarm	R	0=Normal 1=Alarm		air_linkage_fail	BV:7030
Supply Air Temperature Alarm	R	0=Normal 1=Alarm		sat_alarm	BV:7004

Appendix C: Module Status field descriptions

Field	Description
ADDRESS BINDING	<p>The controller's:</p> <ul style="list-style-type: none"> • Device Instance • Network number • MAC address <p>See <i>To set up the controller through the Comm/Service ports</i> (page 57).</p>
Date/Time	Date and time the Modstat was run
Model Name	Identifies the Product Type
Device Instance	A unique ID assigned to the controller
Driver built	When the driver was built
Downloaded by	When and where the last download was performed
Application Software Version	The name of the first control program that is downloaded
Data Partition Version	Not applicable to this device.
# PRGs initialized # PRGs running	If applicable, the number of control programs that were downloaded vs. the number that are running. If these numbers are not the same, the controller has a problem such as lack of memory.
Driver version	The name, version, and date of the driver, as well as all the bundles and versions.
Reset Counters:	The number of times each of the following events have occurred since the last time the controller was commanded to clear the reset counters. See NOTE below this table.
Power failures	Interruption of incoming power
Commanded boots	Includes commands issued from the i-Vu® interface such as the zap manual command, plus commands issued during a memory download.
System errors	Error in the controller's firmware or hardware
S/W Watchdog timeouts	Watchdog is firmware that monitors the application firmware for normal operation. If the watchdog firmware detects a problem, it restarts the application firmware.
H/W Watchdog timeouts	H/W Watchdog will restart the controller if it detects a severe problem with the controller's operating system
System status	Gives the current status of the controller's operation. See <i>LEDs</i> (page 67) for all possible conditions.
Network status	Gives the current status of the controller's networks. See <i>LEDs</i> (page 67) for all possible conditions.
System error message history	High-severity errors since the last memory download. Shows the most recent 10 messages. See NOTE below this table.

Field	Description
Warning message history	Low-severity errors and warning messages since the last memory download. Shows the most recent 10 messages. See NOTE below this table.
Information message history	Information-only messages since the last memory download. Shows the most recent 10 messages. See NOTE below this table.
Core and Base board hardware	Gives the following information about the controller's boards: <ul style="list-style-type: none"> Type and board numbers that are used internally by Carrier. The manufacture date and serial number.
Number of BACnet Objects	The number of BACnet objects that were created in the device and the number of those objects that are network visible.
Database Partition	Non-Volatile partition (16 MB maximum) contains data that needs to be preserved through a power cycle and archived to flash such as parameters and trend data. Volatile partition (6 MB maximum) contains data that does not need to be preserved through a power cycle such as status values that are calculated during runtime.
IP Networks - BBMDs	Shows the following information for each active IP network: BBMD Active shows whether the BACnet Broadcast Management Device is currently active (1) or inactive (0). BBMD Entries —the number of entries in the BBMD table (500 maximum). FDT Entries —the number of entries in the Foreign Device Table (500 maximum).
Network Information	The various network addresses for the controller. The Current and Assigned addresses will be the same unless the Enable IP configuration changeover on the BACnet Router Properties page is being implemented.
Statistics and Network Activity	Shows network communication statistics to assist with troubleshooting. See <i>Network Diagnostics - Statistics</i> (page 51) for more information.

NOTE If you want to clear the Reset counters and the three message history fields, click the **Clear Counts/Logs** button on the controller's **Properties** page in the i-Vu® application or in the controller setup **Device** tab.

Document revision history

Important changes to this document are listed below. Minor changes such as typographical or formatting errors are not listed.

Date	Topic	Change description	Code*
7/22/22	To wire and mount the DAT sensor	Changed IN-03 to IN-01	C-AE-BB-O
	CE and UKCA Compliance	Updated for next gen	X-O-BH-E
	FCC Compliance		
5/3/22	CE and UKCA Compliance	Added UKCA Compliance	X-PM-AB-R-BH
	Specifications		
	Specifications	Changed Protocol Revision 15 to Protocol Revision 14	X-PM-AB-E
	Addressing the TV-VVTBP-E2 through the Comm/Service ports	Added Caution regarding USB connection	X-PM-BM-R-BM
	Inputs	Updated pulse counting note	X-TS-RB-R-RB
	Input values	Updated Pulse to Analog information	

* For internal use only



Carrier ©2022 · Catalog No. 11-808-875-01 · 7/22/2022