



BULLET[®] X Vacuum Pump



Operation and Maintenance Manual

Models: 93600, 93610, 93640, 93690

Table of Contents

Page

Features of Your New Pump.....	3
The Purpose of the BULLET®X Design.....	4
Important Steps of Initial Start-up.....	5
Vacuum Tips for Best Performance.....	5, 6
Dual Voltage Motor Power Conversion.....	6
Basic Troubleshooting.....	7
• Four Most Common Problems	
• Oil Leakage	
• The Steps to Solving 95% of All Problems	
Diagnostic Chart.....	8, 9
Replacement Parts.....	10
Warranty and Service.....	11

Important Notices to Purchaser

Check for damage immediately.

Prior to shipment, all YELLOW JACKET® BULLET®X Vacuum Pumps are completely tested and inspected to assure compliance with Ritchie Engineering factory specifications.

If the pump carton is damaged, check contents immediately. Note damage on shipper's bill of lading and have shipper sign your statement. Notify the carrier immediately of the damage to arrange inspection of the pump and packaging.

The CARRIER ALONE is responsible for handling and settling your claim. Ritchie Engineering will cooperate in assessing damage if the pump is returned to the factory prepaid.

CARTON CONTENTS INCLUDE:

- BULLET®X Pump
- Bottle of YELLOW JACKET® Premium Vacuum Pump Oil
- Owner's manual
- Warranty registration card

Warning

- This unit generates a deep vacuum that can be harmful to human tissue. Do not expose any part of the human body to the vacuum.
- Do not operate this unit with the exhaust blocked or restricted. Remove red shipping cap prior to use.
- Keep unit a minimum of 4" (10 cm) from objects to provide adequate cooling of motor.
- Continuous sound pressure level of this unit can exceed 70dB.
- Wear goggles and protective clothing when using this product.

Features of Your New Pump

Heavy duty steel handle for well-balanced carrying

Wide-mouth reservoir port for easy, clean oil fills

1/4" x 3/8" x 3/8" intake fittings with integrated check valve

1/2 HP motor, heavy-duty rotors and bearings

Elongated sight glass for better oil level monitoring

Built-in cooling fins help pump run cool and increase performance

Large brass oil drain for convenient, fast oil changes

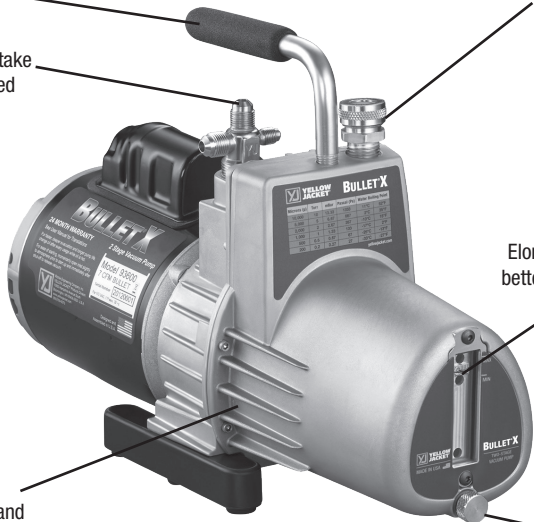

The Purpose of the BULLET®X Design

The BULLET®X Pump is a 2-stage rotary vane design (Fig.1) that increases efficiency and speeds pump down to 30 microns.

The pump lowers the internal pressure of a refrigeration system until moisture boils into a vapor. As the moisture is vaporized, it is evacuated by the pump to help dehydrate the system. Most technicians try to achieve between 250 and 1000 microns.

A manometer or electronic vacuum gauge are the only ways to monitor evacuation progress. Manometer readings are approximate in inches of mercury. Only an electronic vacuum gauge is accurate enough to show when you reach the desired micron range.

As the chart shows, only an electronic gauge reads fine differences to provide assurance that the vacuum is low enough to boil the greatest possible amount of moisture.

Boiling Temp of Water	Inches Mercury	Microns
212°F (100°C)	0	760,000
151°F (66°C)	22.05	200,000
101°F (38°C)	27.95	50,000
78°F (26°C)	28.95	25,000
35°F (2°C)	29.72	5,000
1°F (17°C)	29.882	1,000
-50°F (-46°C)	29.919	50

How One Small Drop Dampens Your Profits.

A small drop of moisture can hurt your profits and reputation.

During new system set-up, protective caps are removed admitting moisture and air into system components.

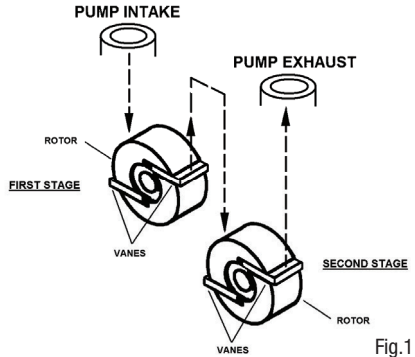

Fig.1

First stage exhausts into the intake of the second stage similar to two single stage pumps connected together.

If air – a non-condensable – remains in the system, it collects on the high side reducing system efficiency. This causes a rise in head pressure. The discharge valve gets hotter than normal and organic solids form causing compressor failure.

Moisture in the system can form ice which closes off openings in expansion valves and cap tubes, and prevent adequate cooling.

Ultimately moisture and air can produce acids and sludge which could cause in-warranty failures.

During service and parts replacement, the same contaminants get in again, and you could be called back for repairs by a dissatisfied customer.

Moisture and air can even enter through system leaks. And as the moisture in the air increases, so does the amount of contamination. The higher the humidity, the bigger your problem.

A vacuum pump “pulls” air and moisture out of the system before the system is damaged. The higher and more complete the vacuum, the more moisture is removed. That’s why your BULLET®X Pump is specifically engineered for high vacuums.

Important Steps of Initial Start-Up

1. Make sure motor is off and name plate voltage on motor bottom matches outlet voltage. (See page 6 for voltage power conversion if voltage mismatch exists)
2. Remove oil fill cap on pump cover. Fill with YELLOW JACKET® BULLET®X Pump Oil until oil level is even with oil level line.
3. **Stay clear of the oil fill/exhaust port!** Remove intake cap to open intake to the atmosphere and then switch on the motor. When pump reaches running speed, replace cap.
4. To check the pump's performance, attach a micron gauge to the 1/4" male flare fitting, making sure that the intake fitting is capped. Turn on the pump. The micron gauge will display the ultimate vacuum reached.
5. Improve cold weather starting by opening intake and running your pump for 1 minute.
6. When turning pump off, open intake fitting to break vacuum just **prior** to shut-off.
7. Disconnect pump and put cap on intake to keep out contaminants.
8. If an extension cord is needed, refer to the below chart for proper sizing.

RECOMMENDED EXTENSION CORD SIZES

Total Extension Cord Length (feet)		
25'	50'	100'
16 Ga.	14 Ga.	12 Ga.
Wire Gauge (AWG)		

Vacuum Tips for Best Performance

Quick Tips:

1. For the fastest vacuum, connect your pump directly to the system. Going through a manifold slows the job.
2. Use as **large** of a hose as possible, even though the system has 1/4" fittings. A 1/2" or 3/8" hose allows a much faster and more complete vacuum.
3. Use as **short** of a hose as practical to get maximum evacuation speed. Short hoses make evacuation faster than longer hoses. Long hoses slow the process.
4. **Metal hoses** are the most impervious so will be most effective in evacuation.
5. Evacuate through both **high and low** sides at the same time to speed up evacuation.
6. Use the **4-in-1 Vacuum/Charge Valve & Core Tool (Part #18975)** to remove the Schrader valves from the system and evacuate through unrestricted lines for a faster and higher vacuum. Removing Schraders saves over 30% in time.
7. Use **two pumps** on very large systems to reduce vacuum time. Put one of the pumps on the low side of the system and one pump on the high side of the system.



8. Use a SuperEvac™ System I or II to decrease vacuum time by over 50%. These systems include a 2-valve vacuum manifold and two 3/8" vacuum hoses which can evacuate three times faster than a 1/4" hose.



9. Use a heat gun on the condenser and evaporator to speed the evacuation process.

If you think there is excessive moisture, blow out the AC&R system with dry nitrogen wherever possible. This reduces the amount of contaminants that must be “pulled” into the pump and increases evacuation speed.

Use a nitrogen regulator valve with pressure limited to 150 psi and a frangible disc device set at 175 PSIG.

Oil Changes: CHANGE OIL AFTER EACH USAGE to protect pump components from contaminants pulled into pump during service. Place used oil in a sealable container and dispose properly in accordance with local regulations.

Dual Voltage Motor Power Conversion (if applicable)

STEP 1

Disconnect the motor from the power supply and remove. Remove the yellow “CAUTION” sticker from the back of the motor.

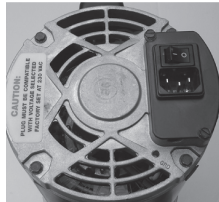

STEP 2

Pull up on the white plastic “arrow” switch using needle-nosed pliers until the switch is loose inside the motor housing (it will not come completely out of the motor).

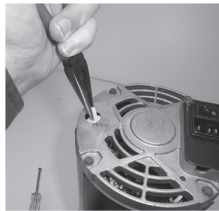

NOTE: Do not try to turn or rotate the switch until it has been pulled up and is loose.

STEP 3

Point the arrow toward the desired voltage setting and push the switch back down into the motor. The arrow on the switch should be sub-flush of the motor housing when correctly installed at the desired voltage.

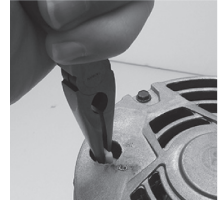

HI = 230 VAC / 50 Hz
LO = 115 VAC / 60 Hz

STEP 4

Replace the yellow “CAUTION” sticker over the voltage selector switch.



Ensure that the voltage setting corresponds with the power supply that the motor is plugged into.*

*Warranty is void if the set vacuum pump voltage does not match the power supply. Dual voltage motors are factory set to 230V/50Hz.

Basic Troubleshooting

Four Most Common Comments on Pump Return Paperwork:

1. **“Will not pump”**. This usually means the pump will not pull a high enough vacuum. This can be caused by valve being left open, missing O-rings under caps or contaminated oil.

SUGGESTION: Change valve and O-rings change oil twice and recheck vacuum.

2. **“Will not pull below 1000 microns”**.

SUGGESTION: Check for O-rings. Test pump to determine actual pull down. Remove all hoses and connect vacuum sensor directly to pump.

3. **“Noisy”**. Pumps are noisy when they have not achieved a high vacuum. In intermediate vacuum, there will be oil, vane and exhaust noises.

SUGGESTION: Listen to the pump at high vacuum. If relatively quiet, the pump is running properly. If still noisy, there may be a system leak.

4. **“Repair and return”**. This is the most difficult return comment to handle, since we are unsure of what needs to be done to keep the customer satisfied.

SUGGESTION: Be specific about the problem with your pump if returning it.

Starting Problems

- Be sure pump is plugged into live receptacle with line voltage plus or minus 10% of voltage on motor nameplate. Long extension cords can greatly reduce voltage and cause problems.
- Pump/oil temperature must be 30°F (-1°C) or higher. Open intake to atmosphere and switch on pump; run up to speed before connecting to system.

- Your BULLET®X Pump features a heavy-duty high torque motor for cold weather starting, but dirty oil makes starting more difficult, causing unnecessary wear on your unit.

- Dropping your pump can damage it. In a locked pump condition, motor will not run and the thermal overload will kick out.

- Disconnect power cord and set pump with front cover face down on table. Reach into coupling area and try to rotate the coupling. Do not use pliers if the pump does not rotate, it is "locked up."

Oil Leakage

- If leak develops between front and rear half of oil case, tighten all screws. Replace gasket if necessary.
- If shaft seal leaks, replace it.
- Wipe pump dry and watch for source of leak. Tighten screws and repair.

The Steps to Solving 95% of All Problems

1. **Check oil level when pump is running.** It should be between the minimum and maximum markings on the cover for proper operation.
2. **Check vacuum pump.** Connect micron gauge directly to the 1/4" port and cap intake port. Turn on pump, open the valve and check vacuum reading. If reading is good, check the system for leaks. OR, if testing a system, isolate pump with blank-off valve and get vacuum reading from the pump alone. If the pump does not pull and stay at a good vacuum level, run until hot and change oil.
3. **Check all flare connections.** Make sure they are tight.

Diagnosics Chart

Condition	Pump Area	Possible Problem	Solution
Poor Vacuum	Quiet pump	Dirty oil Drive coupling or set screw loose Bent or broken exhaust valve Pump not oiling Vaness not functioning	Flush 1 to 3 times Repair or replace Repair or replace Call factory Call factory
	Ultimate of pump does not meet mfg. spec (when read with thermo-couple gauge)	Pump dropped Micron gauge malfunction Poor motor performance Dirty oil Air leaks System leaks Fitting sealant compound	Call factory Verify with second gauge Repair or replace Flush 1 to 3 times Repair or replace Isolate/repair Repair or replace
Oil Leaks	Exhaust	Oil level high System vented pressure through pump Pump tipped over	Adjust oil level Check oil level, add or replace oil Check oil level, add or replace oil
	Seal	Worn or damaged seal Motor loose	Replace Adjust/tighten, check seal
	Case	Gasket bolts loose Oil drain fitting Gasket damaged	Tighten Repair or replace Replace
Pump Won't Start	Motor stalled hot/cold	Damaged motor Damaged pump Closed intake on pumps Low voltage Cold weather cut-out	Repair or replace Replace/call factory Open intake fitting Shorter extension cord Open intake fitting for 10-15 sec. to warm up while starting
Poor Vacuum	Noisy pump	System leaks Low oil level Dirty oil Worn pump Air leaks and fittings or gasket seals	Repair leaks Add/replace Flush 1 to 3 times Replace module, call factory Replace/repair

Diagnosics Chart continued

Condition	Pump Area	Possible Problem	Solution
Unusually Noisy	Motor areas	Worn motor Loose motor bolts Drive coupling	Replace motor Tighten bolts Adjust/replace coupling
	Pump cartridge	Dirt, low, improper oil Air leaks: 1. Caps/connections 2. Gaskets/O-rings 3. Fittings 4. System leak	Flush and replace oil Tighten Replace/put on oil Replace/reseal Isolate pump with blank-off Value and repair system leak
High Temperature	Motor	Low voltage	Use properly sized extension cord
	Pump	Dirty oil Low oil Parts friction Too small for system Air leaks	Flush and replace Add/replace Replace oil/call factory Size pump for system Replace/repair

Replacement Parts

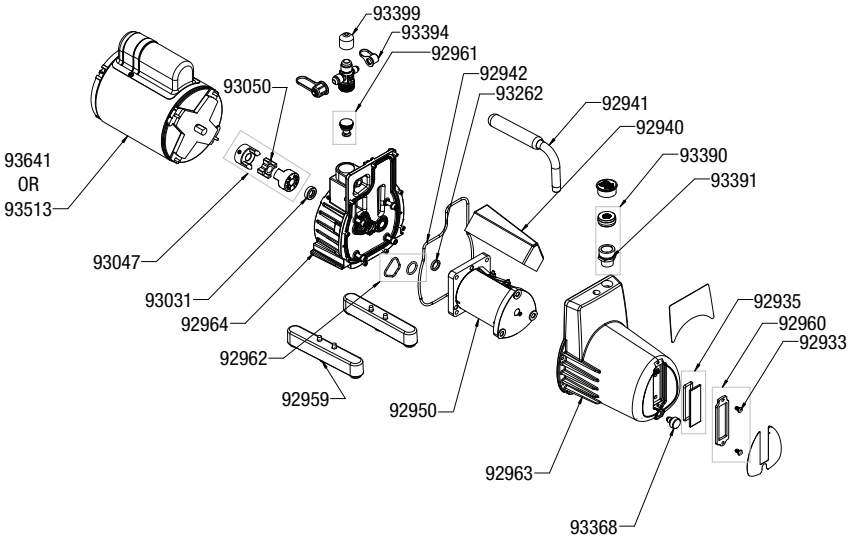

Part #	Description	Part #	Description
93641	Motor	93394	1/4 Flare Cap and Strap
93513	1/2 hp Motor Dual Voltage 115/60, 230/50hz	93399	3/8 Flare Cap and Strap
93031	Shaft Seal	92941	Bullet Pump Handle
92959	Universal Pump Leg	92961	Bullet Anti Suckback asm
93047	Drive Coupling	95431	8' EU Cord Detachable iec-320
93050	Coupling Spider For 93047	95432	8' UK Cord Detachable iec-320
93262	Cartridge Centering Ring	92950	7 cfm Cartridge with Intake Gasket
92933	Sight Glass Screws	92942	Pump Cover Gasket
92935	Sight Glass (Glass+ O-Ring Only)	92940	Cartridge Baffle
92960	Sight Glass (Bezel + Screws Only)	92962	Cartridge Gasket
93368	Oil Drain Plug asm	92963	Pump Cover Assembly
93390	Oil Fill Cap asm	92964	Mount Body Assembly
93391	Oil Fill Fitting		

Damaged supply cords must be replaced by special assemblies available from the manufacturer or its distributors

Warranty Information

Ritchie Engineering guarantees YELLOW JACKET® products to be free of defective material and workmanship which could affect the life of the product when used for the purpose for which it was designed. This warranty does not cover items that have been altered, abused (including failure to use the correct type of vacuum pump oil) or returned solely in need of field service maintenance.

If found defective, we will either replace or repair at our option products within warranty period. Returns must be prepaid.

Warranty does not cover use of lithium bromide, ammonia or leak stop type products.

See www.yellowjacket.com to register your product or contact customer service for full warranty details.

How to Obtain Service

Most returned pumps are merely in need of normal field service maintenance, such as changing oil or making minor adjustments. In many instances, the troubleshooting information in this manual can save you the time and effort of returning your pump. When the information contained in this manual, however, does not solve the problem, please call for service.

Contact the Ritchie Engineering Customer Service Department:

Phone: (952) 943-1333 or
(800) 769-8370

Fax: (952) 943-1605 or
(800) 322-8684

E-mail: custserv@yellowjacket.com

You will receive personal help to determine if the problem can be solved without sending your pump to the factory and taking it out of service.



Ritchie Engineering Company, Inc.
YELLOW JACKET® Products Division
10950 Hampshire Avenue South
Bloomington, MN 55438-2623 USA

E-mail: custserv@yellowjacket.com
Website: www.yellowjacket.com

Phone: (800) 769-8370
(952) 943-1333 INTL

Fax: (800) 322-8684
(952) 943-1605 INTL

