

**KSAHI0401R22  
KAAHI0501PUR  
KSAHI0401PUR**

**High-Pressure Switch Kit**

# Installation Instructions

**NOTE:** Read the entire instruction manual before starting the installation.

## SAFETY CONSIDERATIONS

Installing and servicing air conditioning equipment can be hazardous due to system pressures and electrical components. Only trained personnel should install or service air conditioning equipment.

Untrained personnel can perform basic maintenance functions such as cleaning coils, or cleaning and replacing filters. All other operations should be performed by trained service personnel. When working on air conditioning equipment, observe precautions in the literature, on tags, and on labels attached to the unit.

Recognize safety information. This is the safety-alert symbol . When you see this symbol on the unit and in instructions or manuals, be alert to the potential for personal injury.

Understand these signal words; DANGER, WARNING, and CAUTION. These words are used with the safety-alert symbol. **DANGER** identifies the most serious hazards which **will** result in severe personal injury or death. **WARNING** signifies hazards which **could** result in personal injury or death. **CAUTION** is used to identify unsafe practices which **may** result in minor personal injury or product and property damage. **NOTE** is used to highlight suggestions which **will** result in enhanced installation, reliability, or operation.

Follow all safety codes. Wear safety glasses and work gloves.

## **WARNING**

### **ELECTRICAL SHOCK HAZARD**

Failure to follow this warning could result in personal injury or death.

Before beginning any installation or modification, be sure the main electrical disconnect switch is in the OFF position. TAG THE DISCONNECT SWITCH WITH A SUITABLE WARNING LABEL.

Use only the kit components described in this installation procedure.

## INTRODUCTION

### **WARNING**

#### **PERSONAL INJURY AND/OR PROPERTY DAMAGE HAZARD**

Failure to follow this warning could result in personal injury, death and/or property damage.

High-Pressure Switch Kit KSAHI0401R22 **must** be installed when heat pump is used with a gas furnace (dual fuel) application.

These instructions cover installation of High-Pressure Switch Kit KSAHI0401R22 on split system air conditioners and heat pumps containing R-22 refrigerant, KAAHI0501PUR on air conditioners containing Puron® (R-410A) refrigerant and KSAHI0401PUR on heat pumps containing Puron® (R-410A) refrigerant.

#### Kit contents:

- High-Pressure Switch- 1
- Adapter Tee, AC (KAAHI0501PUR) - 1
- Pressure Switch Adapter Tube, AC (KAAHI0501PUR) - 1
- Pressure Switch Adapter, HP (KSAHI0401PUR) - 1
- Installation Instructions - 1
- DD24FA051 Flare Gaskets, AC (KAAHI0501PUR) - 2

## INSTALLATION

# ⚠ CAUTION

### EQUIPMENT DAMAGE AND/OR OPERATION HAZARD

Failure to follow this caution may result in equipment damage or improper operation.

When making flare connections, use one of the flare gaskets provided in the kit to ensure a leak-tight refrigerant connection. Use a backup wrench to avoid breaking connection or splitting flare.

**NOTE:** The liquid- and vapor-service valves are located outside of the unit at the rear. The smaller valve is the liquid-service valve; the larger valve is the vapor-service valve.

### HIGH-PRESSURE SWITCH INSTALLATION (FOR AIR CONDITIONERS)

Refer to Fig. 1 and proceed as follows to install the high-pressure switch.

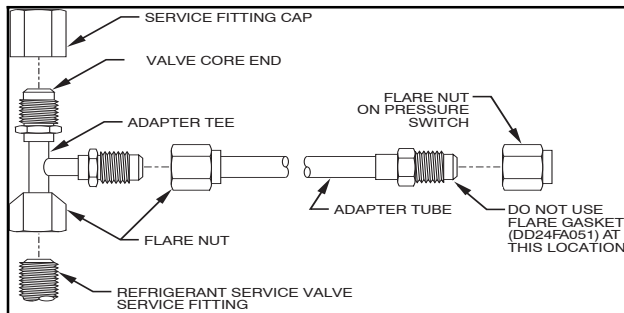

A05081

**Fig. 1 - High-Pressure Switch Refrigerant Connections for Air Conditioners**

**NOTE:** Make sure the liquid-service valve is in the fully back seated (counterclockwise) position before installation (Back seating service valves have no valve core in the service port).

**NOTE:** When installing both high- and low-pressure switches on liquid-service valve, connect second tee to service fitting of first tee.

1. For vertical discharge units, remove knockout in service panel next to service valves. For horizontal discharge units, either drill a hole in the service valve plate or route switch through existing service valve holes.
2. Securely connect pressure switch adapter tube flare nut to side of adapter tee without valve core.
3. Route the adapter tube completely through the knockout (vertical discharge units) or service valve hole (horizontal discharge units) so that tee can be attached to liquid service valve later.
4. Securely connect pressure switch flare nut to male flare fitting on adapter tube inside the unit. Using backup wrench, torque to 140 in. lb.
5. Remove seal cap from service fitting on liquid-service valve and securely connect to remaining male flare fitting on adapter tee.
6. Securely connect flare nut on adapter tee to service fitting on liquid-service valve.
7. On back seating valves, remove liquid-service valve stem cap and open valve 3/4 turn.
8. Replace liquid-service valve stem cap fingertight and further tighten cap 1/12 turn.
9. Check all refrigerant connections for leaks and repair if necessary.

## HIGH-PRESSURE SWITCH INSTALLATION (FOR HEAT PUMPS)

Refer to Fig. 2 and proceed as follows to install the high-pressure switch.

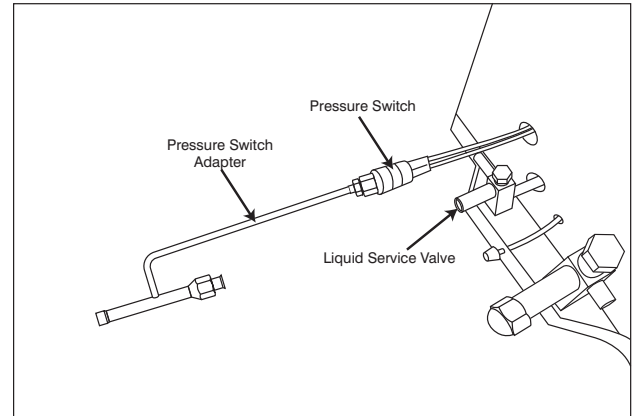

A07574

**Fig. 2 - High-Pressure Switch Adapter Connections**

**NOTE:** When installing the pressure switch adapter to a previously installed unit, the unit must be pumped down and the field-installed liquid line disconnected. Refer to Pump-down Procedure in the Split System Residential Air Conditioning and Heat Pump Service Manual.

1. For vertical discharge units, remove knockout in service panel next to liquid service valve. For horizontal discharge units, either drill a hole in the service valve plate or route switch through existing service valve holes.
2. Securely connect pressure switch flare nut to male flare fitting on the pressure switch adapter tube inside unit. Using backup wrench, torque to 140 in. lb.
3. Route the assembly from Step 2 end of the pressure switch adapter tube through the knockout hole (vertical discharge) or service valve hole (horizontal discharge). The long 1/4" copper tube may need to be slightly bent beyond the service panel to miss the coil's vapor header.
4. Remove sweat adapter from field liquid line fitting on service fitting on liquid-service valve and securely connect 3/8-in. tube portion of pressure switch adaptor.
5. Braze interconnecting liquid line to belled end of pressure switch adaptor.

# ⚠ CAUTION

### EQUIPMENT DAMAGE HAZARD

Failure to follow this caution may result in equipment damage or improper operation.

To prevent melting of the 1/4-in. OD tube joint, place a wet cloth at the joint area.

6. Check all refrigerant connectors for leaks and repair if necessary.
7. Evacuate indoor coil and refrigerant lines.
8. Open service valves and let charge back into system.
9. Make pressure switch electrical connection per Step 3.

## ELECTRICAL CONNECTION

See Fig. 3 for Air Conditioners and Figs. 4 and 5 for Heat Pumps.

1. Locate unit contactor coil terminals or, if equipped, compressor time delay terminal T1.
2. On units without compressor time delay, make electrical connections as follows:
  - a. One pressure switch in unit: Disconnect Y lead from contactor coil terminal. Connect 1 pressure switch lead to Y lead. Connect other pressure switch lead to contactor coil terminal.
  - b. Both high- and low-pressure switches in unit: Disconnect Y lead from contactor coil terminal. Connect 1 high pressure switch lead to Y lead, then connect other high-pressure lead to 1 low-pressure lead. Connect remaining low-pressure lead to contactor coil terminal.
  - c. With a factory installed low-pressure switch: Disconnect the low-pressure switch lead from Y connection on control board. Connect 1 high-pressure switch lead to Y, then connect other high-pressure lead to the disconnected low-pressure lead.
3. On units with compressor time delay, make electrical connections as follows:
  - a. One pressure switch in unit: Disconnect wire leading to T1 on time delay board. Connect 1 pressure switch lead to disconnected lead. Connect other pressure switch lead to T1 on time delay board.
  - b. Both high- and low-pressure switches in unit: Disconnect wire leading to T1 on time delay board. Connect 1 high-pressure lead to disconnected lead, then connect other high-pressure lead to 1 low-pressure lead. Connect remaining low-pressure lead to T1 on time delay board.
  - c. With a factory installed low-pressure switch: Disconnect the low-pressure switch lead from T1 on time delay board. Connect 1 high-pressure switch lead to T1, then connect other high-pressure lead to the disconnected low-pressure lead.
4. Restore power and check unit operation.

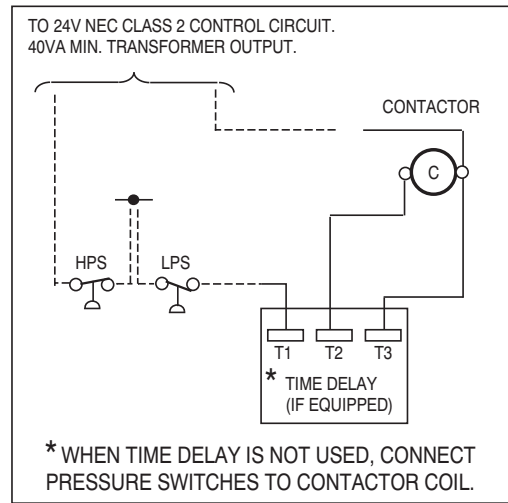

**Fig. 3 - Air Conditioner Electrical Connections**

A07630

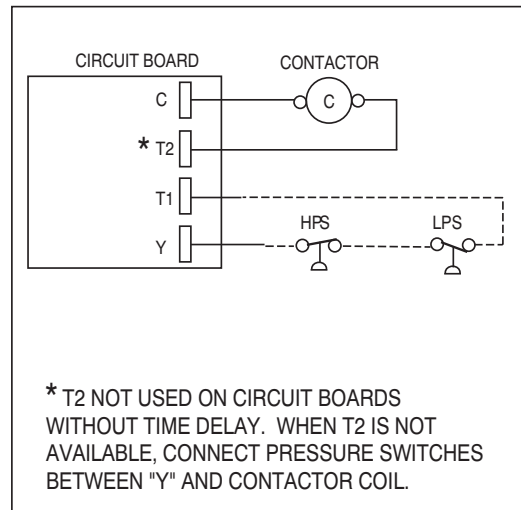

**Fig. 4 - Heat Pump Electrical Connections**

A07629

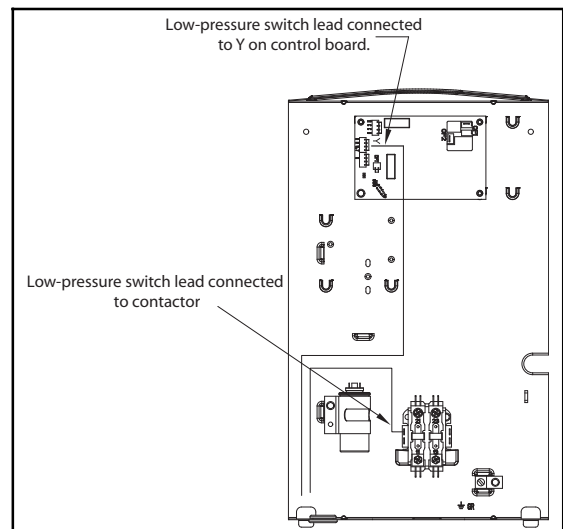

**Fig. 5 - Heat Pump Electrical Connections**

A07575

