

LEVEL UP YOUR ECM REPAIR KIT

with a tester that's as easy as it is affordable.

FEATURES & SPECIFICATIONS:

- provides functional testing for ECM 2.3, ECM 3.0, and X13 (Including Evergreen® and Rescue® ECM products)
- Easy to use: Gives a “go”/”no go” result
- Operating voltage: 24 VAC
- No batteries required
- Wire length: 24”
- 24 VAC indicating light
- Test light indicator (Start)
- Short circuit protection
- Magnetic case
- Unit weight: 5.5 oz

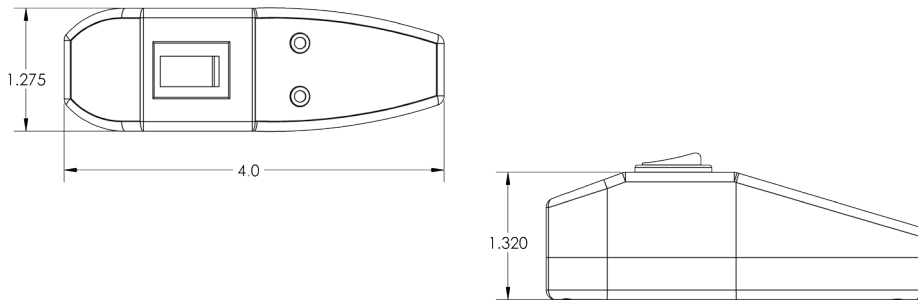

WARNINGS:

- This tool was designed to be used by trained and qualified technicians. Always verify the system voltage matches the manufacturer's nameplate prior to troubleshooting with the ECMPRO.
- Always disconnect power from the HVAC system prior to troubleshooting, removing, and replacing the motor.
- When troubleshooting ECM motors, always wait 5 minutes after disconnecting the power from the HVAC system to avoid potential electric shock.

NOTE: It is normal for an ECM motor to rock back and forth at start up. This is not an indication of potential failure of an ECM motor.

The SUPCO® Universal ECM Tester provides functional testing for ECM 2.3, ECM 3.0, and X13 (Including Evergreen® and Rescue® ECM products).

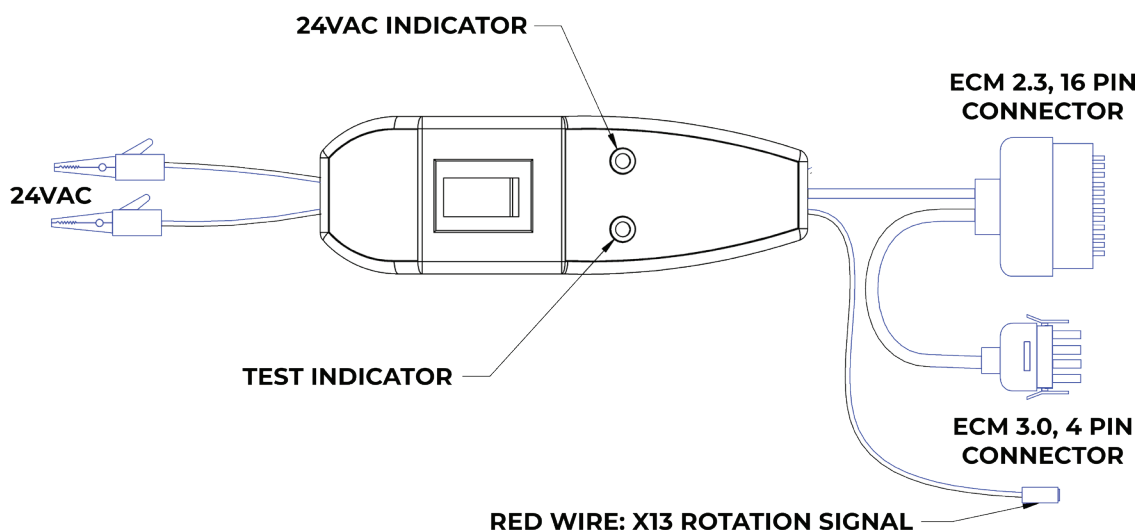

CONNECTING THE ECMPRO TO THE MOTOR

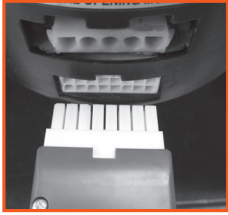

ECM 2.3

Disconnect power to the HVAC system. Wait 5 minutes. Remove only the 16-pin connector from the motor and connect the 16-pin connector from the ECMPRO to the motor. Connect the two alligator clips to the system 24 VAC.

NOTE: The high voltage 5-pin connector must be connected to the ECM motor for ECMPRO testing.

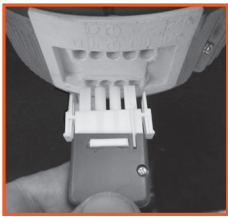

ECM 3.0

Disconnect power to the HVAC system. Wait 5 minutes. Remove only the 4-pin connector from the motor and connect the 4-pin connector from the ECMPRO to the motor. Connect the two alligator clips to the system 24 VAC.

NOTE: The high voltage 5-pin connector must be connected to the ECM motor for ECMPRO testing.



X13, Evergreen® & Others

The 3/16" spade terminals on these motors (top three in the center) are connected to the motor power and identified as Line, Ground and Neutral, in that order (left to right). The top left terminal is a 1/4" spade and is a control common. Disconnect power to the HVAC system. Wait 5 minutes. Connect the red wire from the ECMPRO to the 1/4" spade at the bottom left motor terminal (terminal #1). Connect the two alligator clips to the system 24 VAC.

NOTES:

- The high voltage wiring must be connected to the X13 motor for ECMPRO testing.
- Sometimes it may be necessary to remove the Common Wire from the X13 motor and connect the ECMPRO black wire with alligator clip to the motor Common terminal.
- Broad Ocean® motors have the same terminal arrangement but the connector is not attached to the motor.

ONCE THE ECMPRO IS CONNECTED TO THE MOTOR

Ensure the ECMPRO switch in the "Off" position, turn the system power on. The LED will light up indicating that the unit is receiving 24 VAC power. Turn the ECMPRO switch to "On." After a few second delay, observe the motor operation for a minimum of 15 seconds.

IF THE MOTOR OPERATES WITH THE ECMPRO, check the harness from the equipment manufacturer's control board to the motor for broken wires/harness/pin connections. After verifying the harness is in good condition, follow the original equipment manufacturer's control board troubleshooting guide.

IF THE MOTOR DOES NOT OPERATE WITH THE ECMPRO, please follow the troubleshooting guidance from the motor manufacturer to determine whether the failure is in the motor or the module.

Have questions or need help?
 Email techsupport@supco.com or call 1-800-333-9125 Ex: 261

References to other manufacturers' names, models, trademarks and part numbers are used for identification purposes only and SUPCO® replacement products are not in any way affiliated, endorsed or sponsored by such other manufacturers.