



SERVICE PARTS LIST

BULLETIN NO.
54-27-2481

SPECIFY CATALOG NO. AND SERIAL NO. WHEN ORDERING PARTS		REVISED BULLETIN 54-27-2480	DATE June 2015
12 Volt PVC Shear			
CATALOG NO.	2470-20	STARTING SERIAL NO.	C28B
		WIRING INSTRUCTION SEE PAGES 2 & 3	

EXAMPLE:
Component Parts (Small #)
Are Included When Ordering
The Assembly (Large #).

★ = Part number change from
previous service parts list.

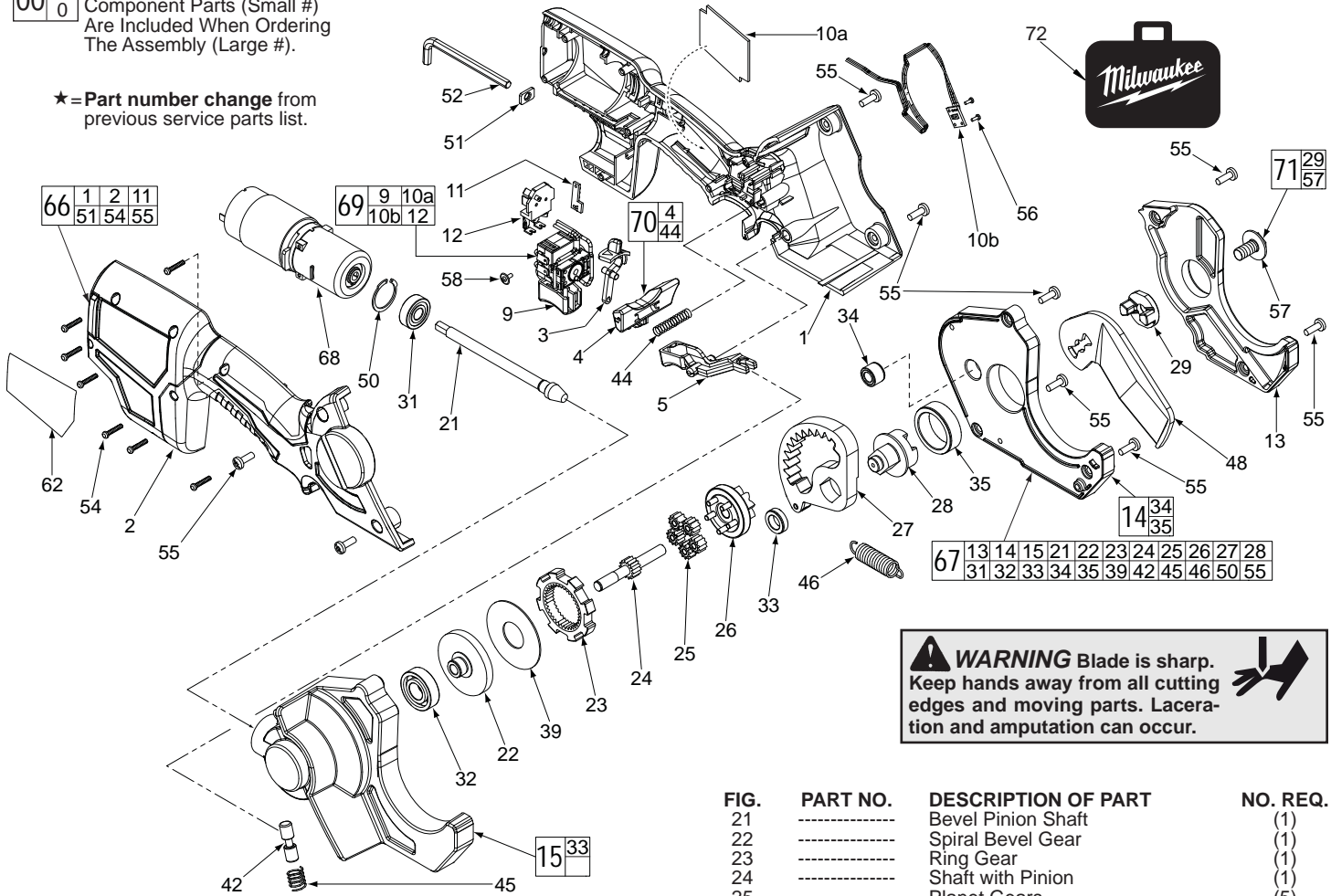

WARNING Blade is sharp. Keep hands away from all cutting edges and moving parts. Laceration and amputation can occur.

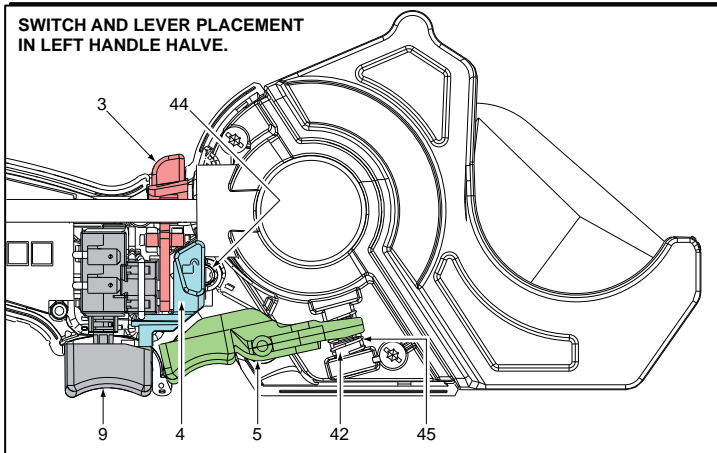

FIG.	PART NO.	DESCRIPTION OF PART	NO. REQ.
1	-----	Handle Halve - Left	(1)
2	-----	Handle Halve - Right	(1)
3	42-42-0640	Forward / Reverse Lever	(1)
4	-----	Lockout Lever	(1)
5	44-10-0750	Blade Quick Release Lever	(1)
9	-----	Switch	(1)
10a	-----	PC Board	(1)
10b	23-66-2005	Blade Shut-Off Switch	(1)
11	-----	Fuel Gauge	(1)
12	-----	Terminal Block Assembly	(1)
13	28-14-2340	Front Gearcase - Left	(1)
14	28-14-2345	Front Gearcase - Center	(1)
15	28-14-2350	Front Gearcase - Right	(1)

FIG.	PART NO.	DESCRIPTION OF PART	NO. REQ.
21	-----	Bevel Pinion Shaft	(1)
22	-----	Spiral Bevel Gear	(1)
23	-----	Ring Gear	(1)
24	-----	Shaft with Pinion	(1)
25	-----	Planet Gears	(5)
26	-----	Carriage Gear	(1)
27	-----	Internal Gear	(1)
28	32-75-3500	Blade Hub Spindle	(1)
29	43-72-0560	Blade Holder	(1)
31	-----	Ball Bearing	(1)
32	02-04-1210	Ball Bearing	(1)
33	-----	Blade Hub Bushing	(1)
34	-----	Bushing	(1)
35	-----	Blade Hub Bushing	(1)
39	-----	Washer	(1)
42	44-50-0300	Blade Quick Release Pin	(1)
44	40-50-0270	Compression Spring	(1)
45	40-50-1980	Blade Quick Release Spring	(1)
46	40-50-1650	Blade Extension Return Spring	(1)
48	48-44-0405	PVC Cutter Blade Replacement	(1)
50	-----	Inverted Retaining Ring	(1)
51	44-86-0650	Hex Key Retainer	(1)
52	45-96-0325	3/16" Hex Key	(1)
54	06-82-2385	M2.6 x 14mm T-8 Screw	(7)
55	06-82-2380	8-32UNC x .472" T-20 Screw	(9)
56	05-89-0600	0-80 x .14" Screw	(2)
57	-----	5/16 x 1/2" Screw	(1)
58	05-81-0535	M2.3 Washer Screw	(1)
62	12-20-2472	Service Nameplate	(1)
★66	31-44-2290	Handle Halve Kit	(1)
67	14-30-1020	Front Gearcase Assembly	(1)
68	23-30-0800	Motor & Rear Gearcase Assembly	(1)
★69	23-66-3095	Switch Assembly	(1)
★70	31-76-0210	Lockout Shuttle Assembly	(1)
71	43-72-0700	Drive Attachment	(1)
72	42-55-2470	Carrying Case	(1)

**ADDITIONAL SERVICE NOTES AND WIRING
LOCATED ON PAGES 2, 3 & 4 OF BULLETIN**

MILWAUKEE ELECTRIC TOOL CORPORATION
13135 W. Lisbon Road, Brookfield, WI 53005
Drwg. 3

PVC SHEAR WIRING DIAGRAM

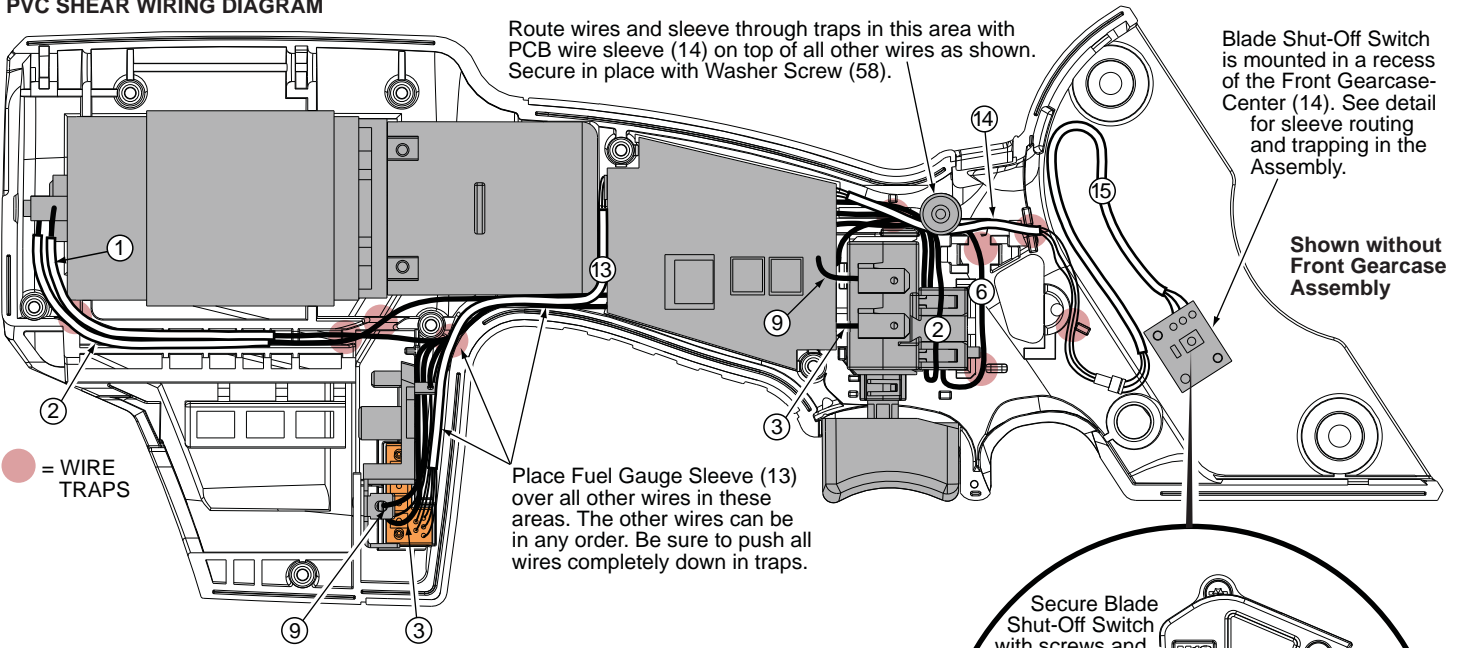

Be sure the sleeve from Blade Shut-Off Switch (15) is routed along the outside of the Front Gearcase Assembly as shown. Place sleeve in wire traps with very little slack in between.

Left Side-Front Gearcase Assembly

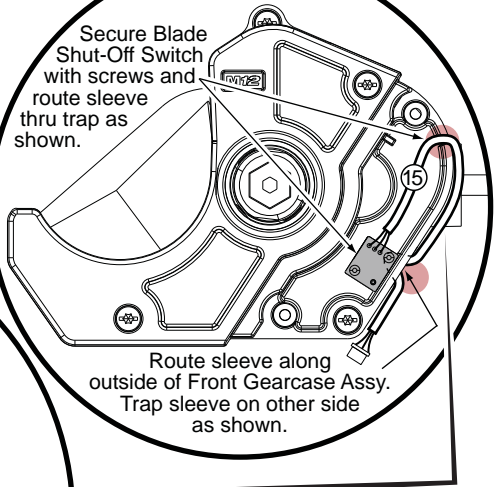
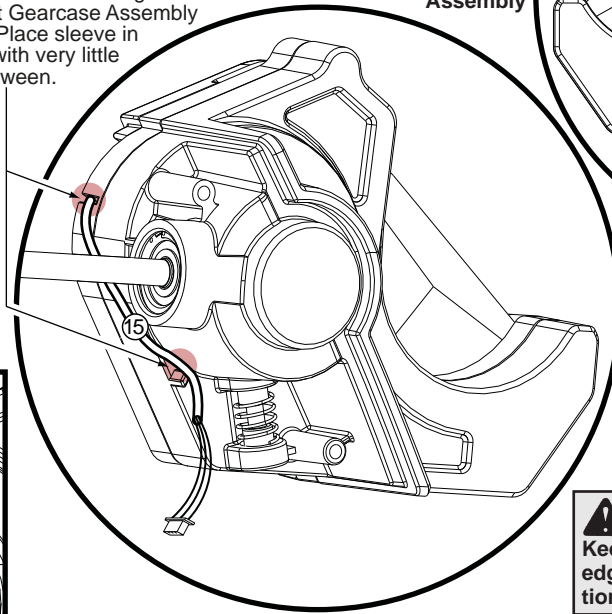

Right Side-Front Gearcase Assembly

WARNING Blade is sharp. Keep hands away from all cutting edges and moving parts. Laceration and amputation can occur.

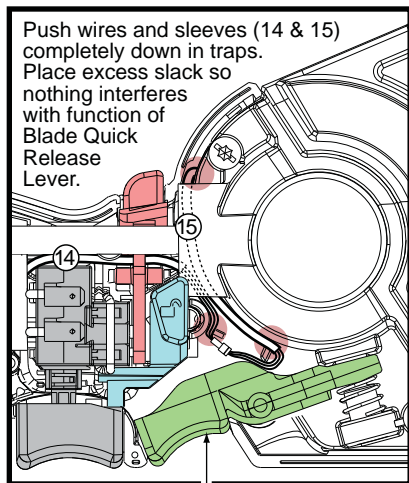

Blade Quick Release Lever.

WIRING SPECIFICATIONS

Wire No.	Wire Color	Origin or Gauge	Length	Terminals, Connectors and 1 or 2 End Wire Preparation
1	Red	Motor Assy.	-----	Connect from Motor (positive terminal) to Switch.
2	Black	Motor Assy.	-----	Connect from Motor (negative terminal) to Switch.
3	Red	Switch Assy.	-----	Attached to the Switch and Terminal Block.
4	Black	Switch Assy.	-----	Attached to the Switch and the PC Board.
5	Red	Switch Assy.	-----	Attached to the Switch and the PC Board.
6	White	Switch Assy.	-----	Attached to the Switch and the PC Board.
7	White	Switch Assy.	-----	Attached to the PC Board and the Terminal Block.
8	Red	Switch Assy.	-----	Attached to the PC Board and the Terminal Block.
9	Black	Switch Assy.	-----	Attached to the PC Board and the Terminal Block.
10	Yellow	Switch Assy.	-----	Attached to the Switch and the PC Board.
11	Blue	Switch Assy.	-----	Attached to the Switch and the PC Board.
12	Black	Switch Assy.	-----	Attached to the Switch and the PC Board.
13	-----	Fuel Gauge	-----	Attach connector end of 5 wire sleeve to PC Board.
14	-----	Switch Assy.	-----	Attach connector end of 3 wire sleeve on PC Board to the corresponding connector on the Blade Shut-Off Switch.
15	-----	Switch Assy.	-----	Attach connector end of 3 wire sleeve on Blade Shut-Off Switch to the corresponding connector on the PC Board.

NOTE: SWITCH ASSEMBLY (23-66-3095) CONSISTS OF: SWITCH, PC BOARD, BLADE SHUT-OFF SWITCH AND TERMINAL BLOCK ASSEMBLY.

FUEL GAUGE IS A COMPONENT OF HANDLE HALVE KIT (31-44-2290).

PVC SHEAR WIRING DIAGRAM - CONTINUED

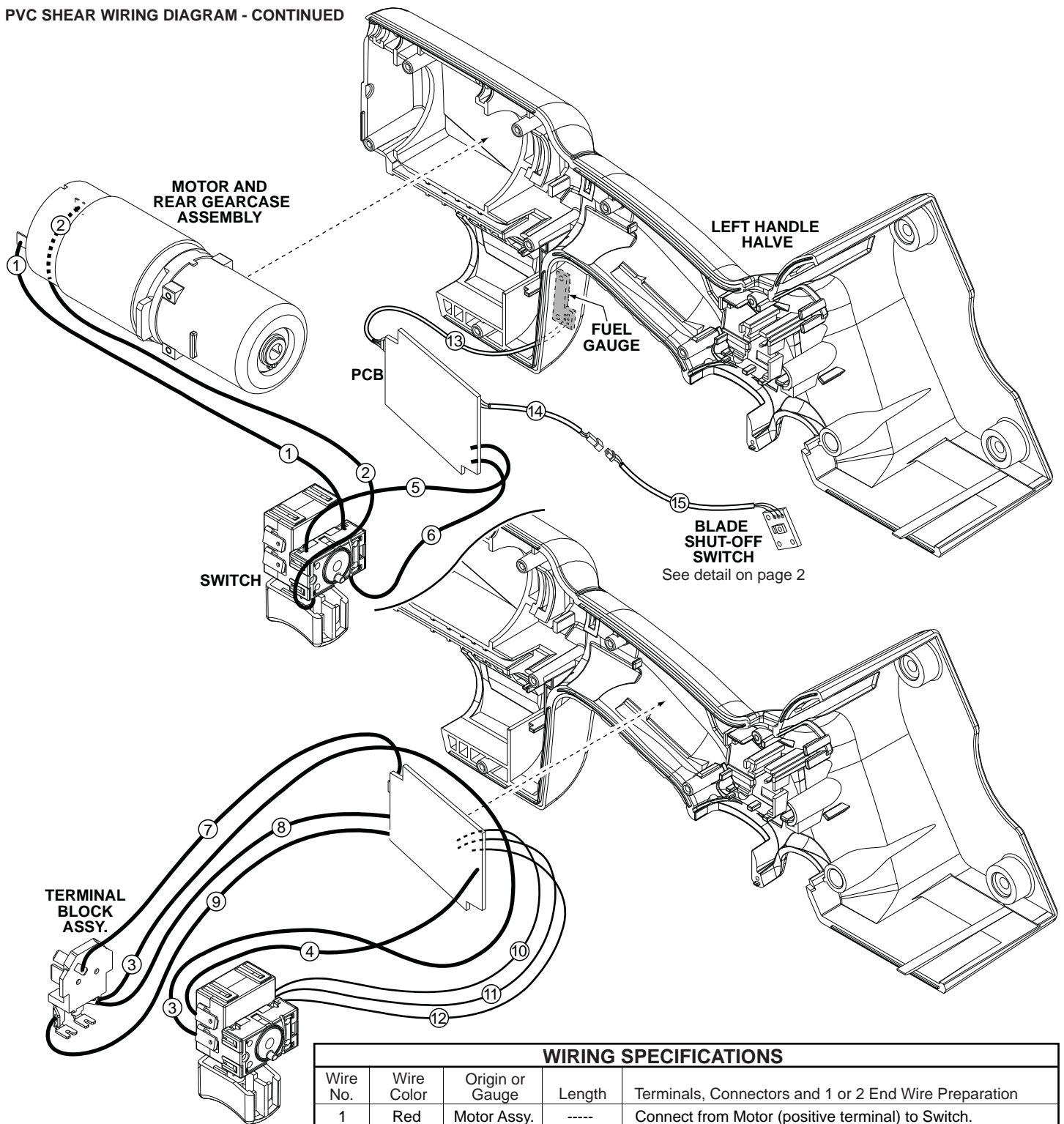

AS AN AID TO REASSEMBLY, TAKE NOTICE OF WIRE ROUTING AND POSITION IN WIRE GUIDES AND TRAPS WHILE DISMANTLING TOOL.

BE CAREFUL AND AVOID PINCHING WIRES BETWEEN HANDLE HALVES WHEN ASSEMBLING.

NOTE: SWITCH ASSEMBLY (23-66-3095) CONSISTS OF: SWITCH, PC BOARD, BLADE SHUT-OFF SWITCH AND TERMINAL BLOCK ASSEMBLY.

FUEL GAUGE IS A COMPONENT OF HANDLE HALVE KIT (31-44-2290).

WIRING SPECIFICATIONS

Wire No.	Wire Color	Origin or Gauge	Length	Terminals, Connectors and 1 or 2 End Wire Preparation
1	Red	Motor Assy.	----	Connect from Motor (positive terminal) to Switch.
2	Black	Motor Assy.	----	Connect from Motor (negative terminal) to Switch.
3	Red	Switch Assy.	----	Attached to the Switch and Terminal Block.
4	Black	Switch Assy.	----	Attached to the Switch and the PC Board.
5	Red	Switch Assy.	----	Attached to the Switch and the PC Board.
6	White	Switch Assy.	----	Attached to the Switch and the PC Board.
7	White	Switch Assy.	----	Attached to the PC Board and the Terminal Block.
8	Red	Switch Assy.	----	Attached to the PC Board and the Terminal Block.
9	Black	Switch Assy.	----	Attached to the PC Board and the Terminal Block.
10	Yellow	Switch Assy.	----	Attached to the Switch and the PC Board.
11	Blue	Switch Assy.	----	Attached to the Switch and the PC Board.
12	Black	Switch Assy.	----	Attached to the Switch and the PC Board.
13	----	Fuel Gauge	----	Attach connector end of 5 wire sleeve to PC Board.
14	----	Switch Assy.	----	Attach connector end of 3 wire sleeve on PC Board to the corresponding connector on the Blade Shut-Off Switch.
15	----	Switch Assy.	----	Attach connector end of 3 wire sleeve on Blade Shut-Off Switch to the corresponding connector on the PC Board.

PVC SHEAR SERVICE NOTES:

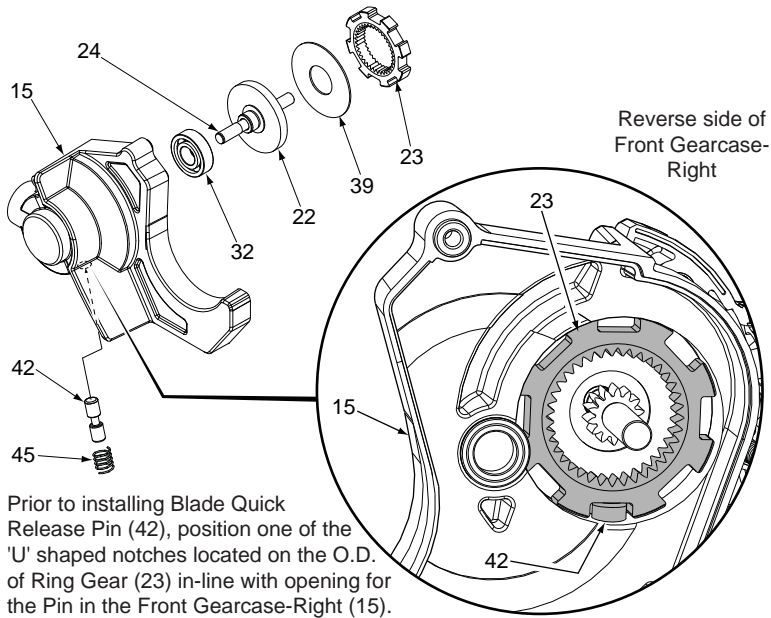

Prior to installing Blade Quick Release Pin (42), position one of the 'U' shaped notches located on the O.D. of Ring Gear (23) in-line with opening for the Pin in the Front Gearcase-Right (15).

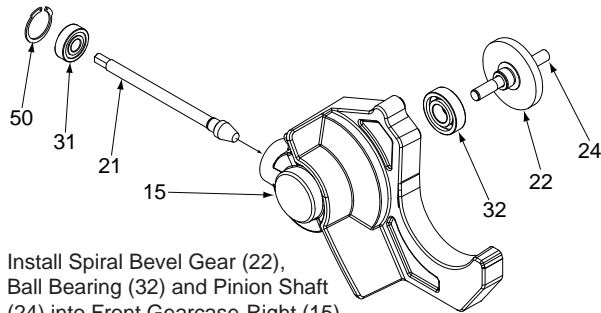

Install Spiral Bevel Gear (22), Ball Bearing (32) and Pinion Shaft (24) into Front Gearcase-Right (15) prior to installing Bevel Pinion Shaft (21), Ball Bearing (31) and Retaining Ring (50).

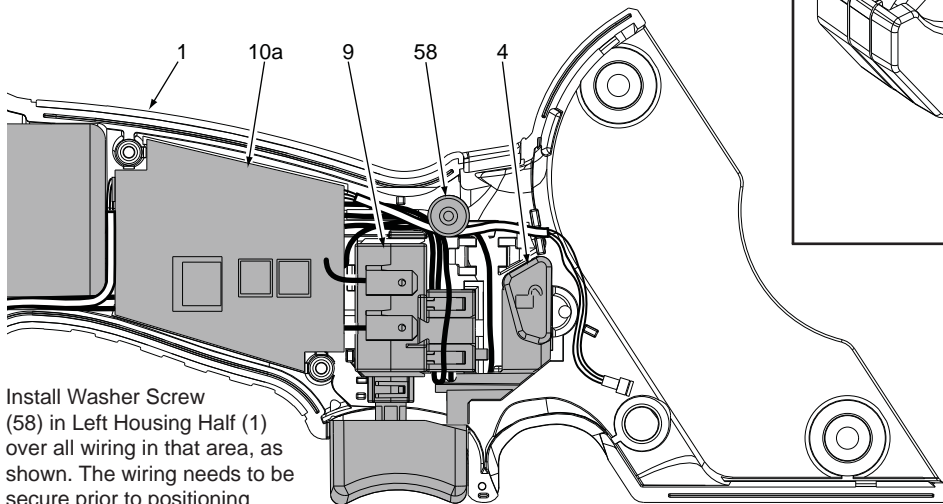

Install Washer Screw (58) in Left Housing Half (1) over all wiring in that area, as shown. The wiring needs to be secure prior to positioning Switch (9) and installing Lock-Out Lever Assembly (4). PC Board (10a) must be fully seated in Left Handle Half.

When servicing tool, **DO NOT** remove the pins holding Motor and Rear Gearcase Assembly (68) together.

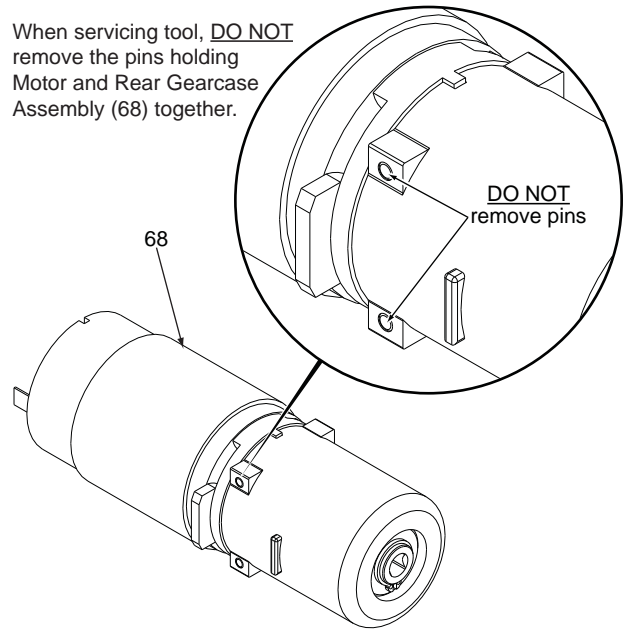

Remove Blade Screw (57) from Blade Hub Spindle by turning counter-clockwise with 3/16" Hex Key (52).

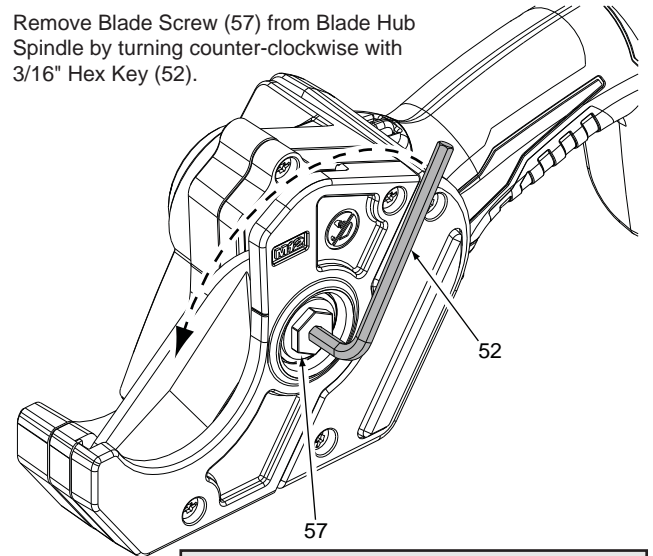

WARNING Blade is sharp. Keep hands away from all cutting edges and moving parts. Laceration and amputation can occur.