



# SERVICE PARTS LIST

**BULLETIN NO.**  
54-27-2472

SPECIFY CATALOG NO. AND SERIAL NO. WHEN ORDERING PARTS		REVISED BULLETIN 54-27-2471	DATE Mar. 2015
<b>M12™ Copper Tubing Cutter</b>		WIRING INSTRUCTION <b>SEE PAGE THREE</b>	
CATALOG NO.	2471-20	STARTING SERIAL NO.	B61C

**EXAMPLE:**  
Component Parts (Small #) Are Included When Ordering The Assembly (Large #).

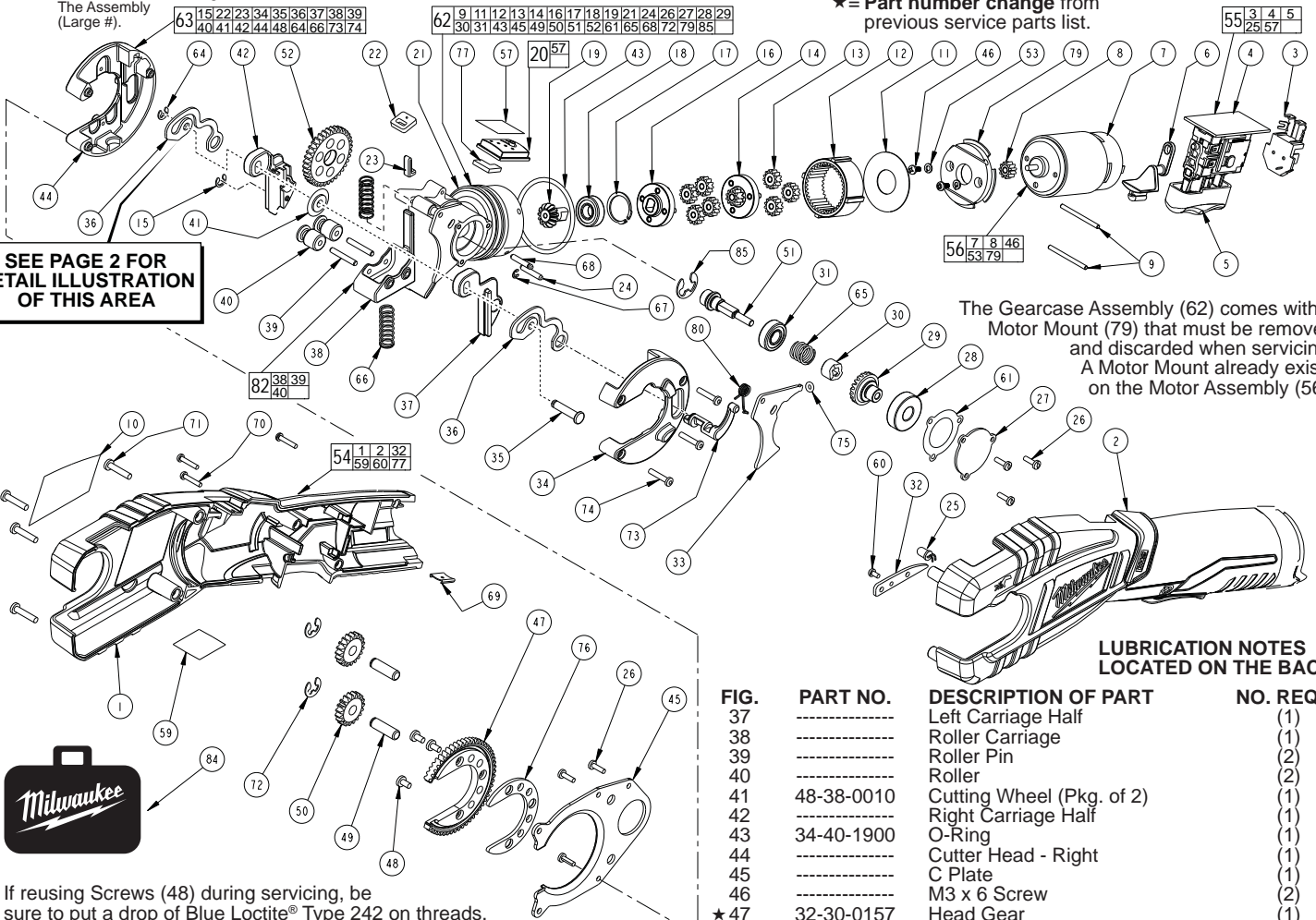

**SEE PAGE 2 FOR  
DETAIL ILLUSTRATION  
OF THIS AREA**

The Gearcase Assembly (62) comes with a Motor Mount (79) that must be removed and discarded when servicing. A Motor Mount already exists on the Motor Assembly (56).

**LUBRICATION NOTES  
LOCATED ON THE BACK**

If reusing Screws (48) during servicing, be sure to put a drop of Blue Loctite® Type 242 on threads.

FIG.	PART NO.	DESCRIPTION OF PART	NO. REQ.
1	-----	Right Handle	(1)
2	-----	Left Handle	(1)
3	-----	Connector Block	(1)
4	-----	PCBA	(1)
5	-----	Switch	(1)
6	31-52-0125	Reversing Lever	(1)
7	-----	Motor	(1)
8	-----	Pinion	(1)
9	44-60-1530	Pin	(2)
10	12-20-2470	Service Nameplate Kit	(1)
11	-----	Plate	(1)
12	-----	Ring Gear	(1)
13	-----	Planet - 1st Stage	(7)
14	-----	Carriage - 1st Stage	(1)
15	42-70-0505	E Clip	(1)
16	-----	Carriage	(1)
17	-----	Snap Ring	(1)
18	-----	Bearing	(1)
19	-----	Bevel Pinion	(1)
20	22-06-0130	Fuel Gauge Assembly	(1)
21	-----	Gearcase Housing	(1)
★22	44-66-0827	Locking Plate	(1)
23	-----	Lifter	(1)
24	-----	Stop Pin	(1)
25	23-28-0020	Service LED	(1)
26	06-82-5268	4-40 x 3/8" Pan Hd. Slit. Tapt. T-10	(6)
27	-----	Plate Cover	(1)
28	-----	Bearing	(1)
29	32-05-0205	Bevel Gear	(1)
30	32-10-0240	Clutch Cam	(1)
31	-----	Bearing	(1)
32	-----	Fixed Cam	(1)
33	44-10-0490	Stop Lever	(1)
34	-----	Cutter Head - Left	(1)
35	42-12-0210	Axle	(1)
36	40-50-0585	Cutting Spring	(2)

FIG.	PART NO.	DESCRIPTION OF PART	NO. REQ.
37	-----	Left Carriage Half	(1)
38	-----	Roller Carriage	(1)
39	-----	Roller Pin	(2)
40	-----	Roller	(2)
41	48-38-0010	Cutting Wheel (Pkg. of 2)	(1)
42	-----	Right Carriage Half	(1)
43	34-40-1900	O-Ring	(1)
44	-----	Cutter Head - Right	(1)
45	-----	C Plate	(1)
46	-----	M3 x 6 Screw	(2)
★47	32-30-0157	Head Gear	(1)
48	05-80-0476	M3.5 x 8mm Flat Head Screw	(3)
49	-----	Axle Pin	(2)
50	-----	Idler Gear	(2)
51	-----	Drive Axle	(1)
52	-----	Drive Gear	(1)
53	-----	M3 Washer	(2)
54	31-44-0246	Handle Set	(1)
55	23-66-0875	Switch PCBA	(1)
56	14-50-0205	Motor Assembly	(1)
57	10-20-4420	Fuel Gauge Label	(1)
59	10-15-0955	Warning Label	(1)
60	-----	M2.6 x 5 Screw	(1)
61	43-44-0075	Gasket	(1)
★62	14-29-0158	Gearcase Assembly	(1)
★63	43-64-0287	Cutter Head Assembly	(1)
64	42-70-0500	E Clip	(1)
65	40-50-0525	Clutch Spring	(1)
66	40-50-0580	Carriage Spring	(2)
67	42-70-0525	E Clip	(1)
68	-----	Pin Pivot	(1)
69	42-70-0058	Housing Connection Clip	(1)
70	06-82-2385	M2.6 x 14 Screw	(3)
71	06-81-0005	M3.5 x 1.34 Screw	(4)
72	42-70-0550	E Clip	(2)
73	36-10-0840	Cam Shaft	(1)
74	05-81-0245	4-40 x 5/8" Phillips Hd. Screw	(3)
75	34-40-1905	O-Ring	(1)
★76	32-30-0161	Head Gear Spacer	(1)
77	42-28-0075	Rubber Block	(1)
79	-----	Motor Mount	(1)
80	40-50-0605	Torsion Spring	(1)
82	43-72-0285	Roller Carriage Assembly	(1)
84	42-55-2471	Carrying Case, Optional	(1)
★85	42-70-0625	E-Clip	(1)

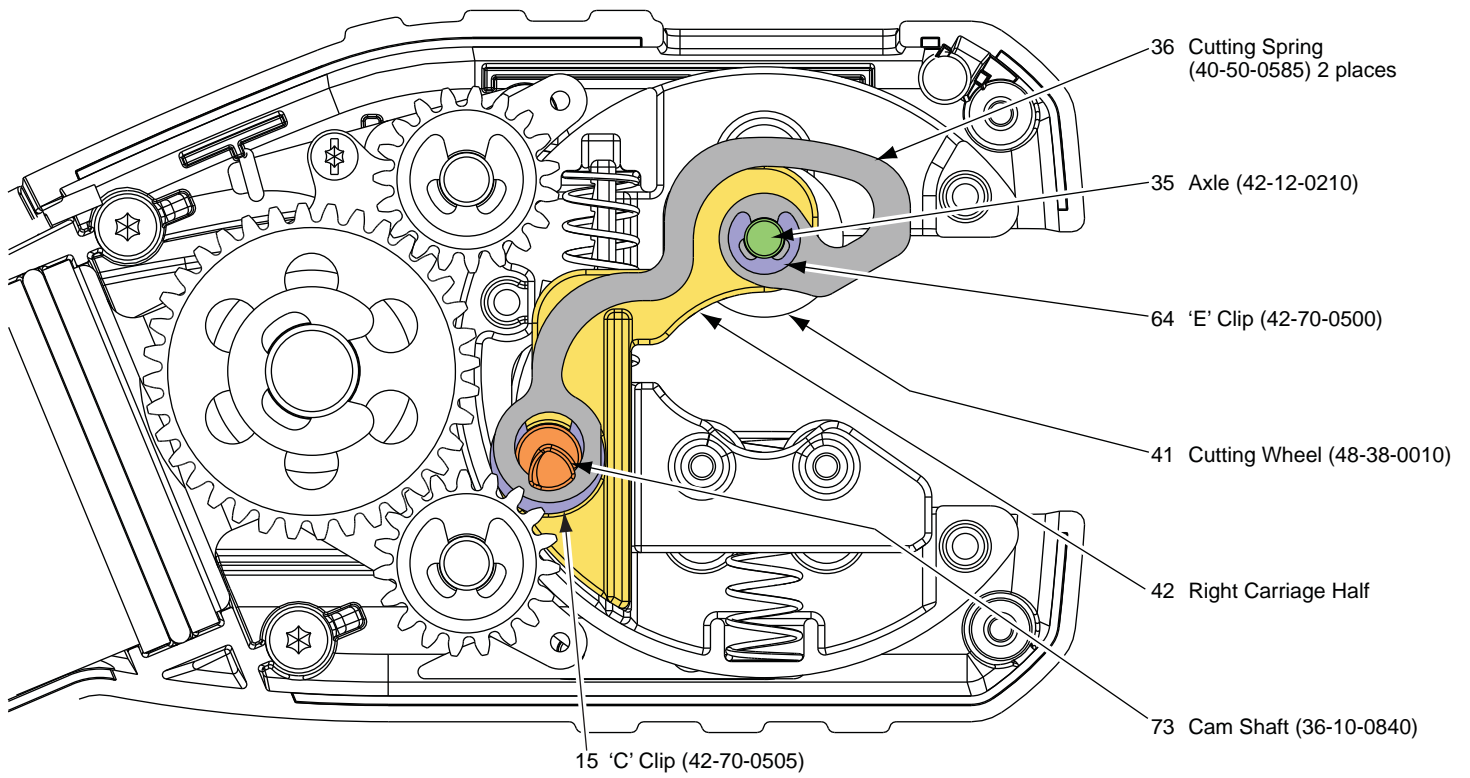

**CUTTER HEAD ASSEMBLY 43-64-0287**  
 Direction of travel for Axle (35) to 'E' Clip (64)

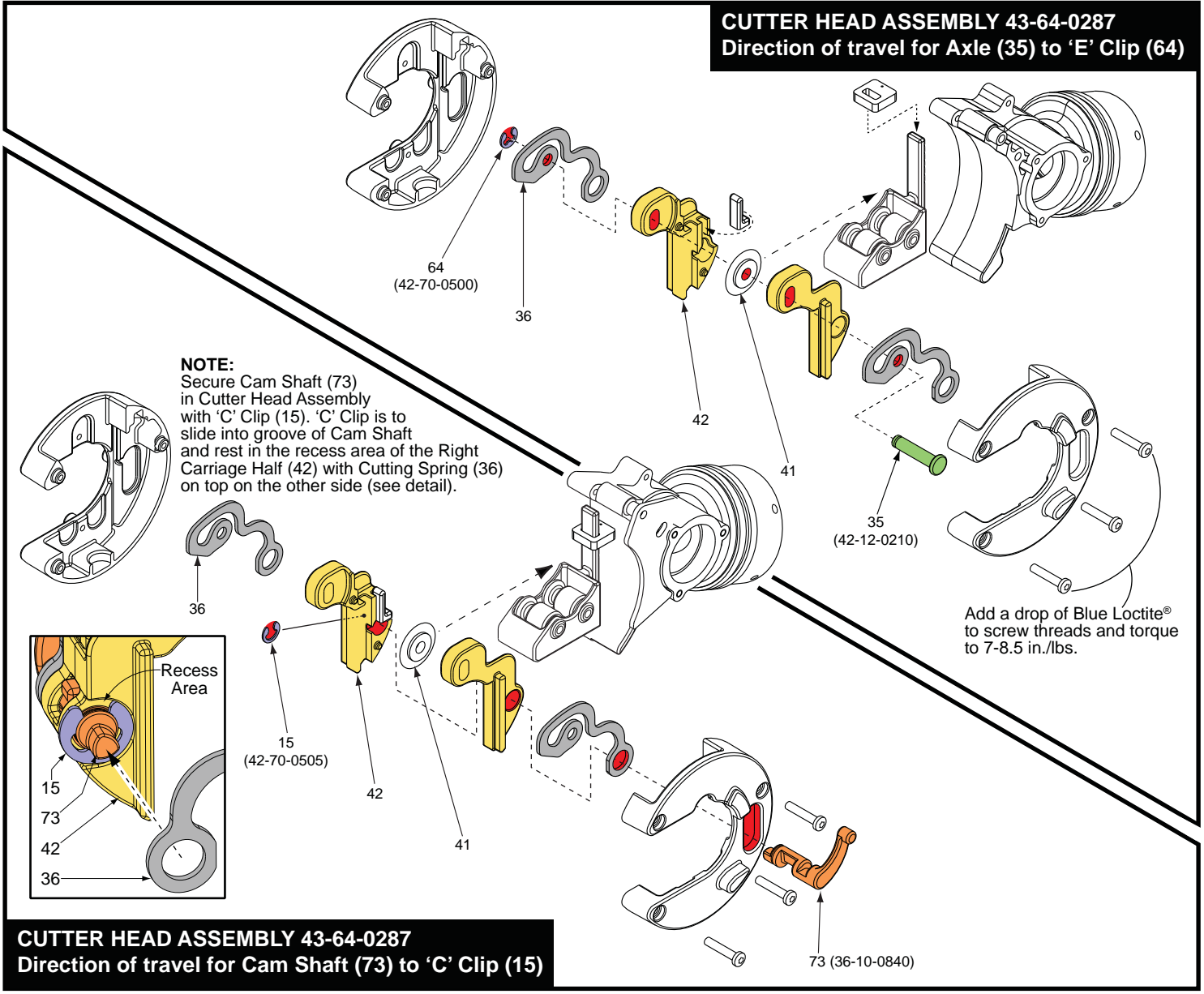

**CUTTER HEAD ASSEMBLY 43-64-0287**  
 Direction of travel for Cam Shaft (73) to 'C' Clip (15)

**FIG. LUBRICATION**

**(Type 'J' Grease, No. 49-08-4220):**

- 38,40 Apply a thin coat of grease to the I.D. of the Rollers (40). Both Rollers must spin freely in the Roller Carriage (38).
- 45,47,63 Grease should be applied liberally to the surfaces of the C-Plate (45) that contact the Cutter Head Assembly (63) and the Head Gear (47).
- 49,50,52 Grease should be applied liberally to the Idler Gear Axles (49), the teeth of the Idler Gears (50) and the teeth of the Drive Gear (52).
- 73 Place a liberal amount of grease to the body of the Cam Shaft (73).
- 23 Place a liberal amount of grease to the body of the Lifter (23).
- 38 Place a liberal amount of grease to the stem of Roller Carriage (38).
- 37,42 Place a liberal amount of grease to the outer surfaces of the Left and Right Carriage Halves (37,42) behind the ribs. Also place grease in the Cutting Wheel slots in the same parts.
- 34,44 Place a liberal amount of grease to the inner surfaces of the Cutter Head Halves (34,44) from the slots for the Right and Left Carriage Halves back, including the slots.
- 35 Place a liberal amount of grease to the Cutting Wheel Axle (35).

For **Service Replacement LED No. 23-28-0020**, splice into wires #10 and #11 from Switch Assembly. Follow instructions immediately below

**For the LED located in the front of the tool:** White wire #10 and red wire #11 are to be routed along the traps in the top of the Left Handle. Secure wires with a drop of RTV adhesive over the short trap and a drop of adhesive over the longer trap towards the front end close to the LED.

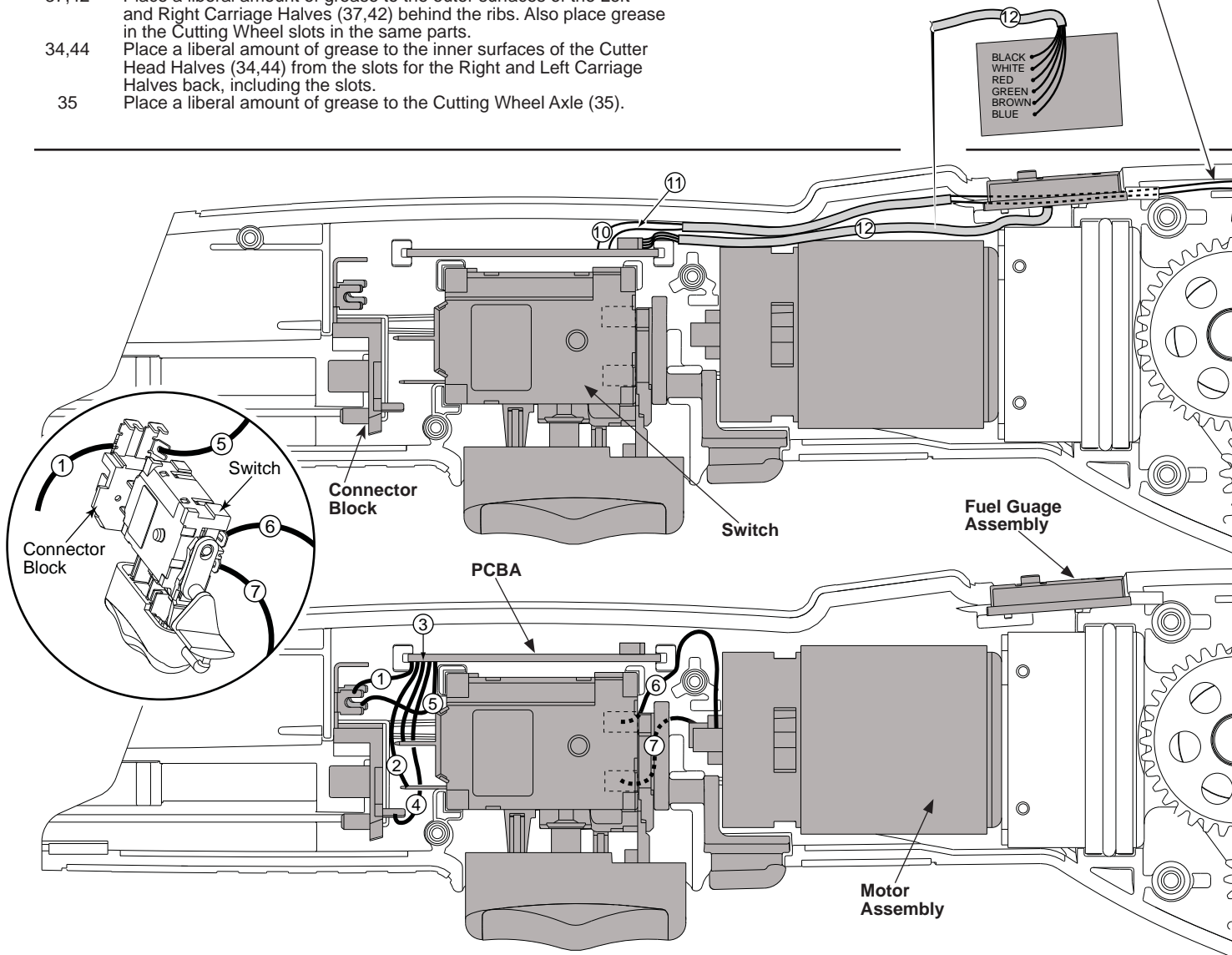

**WIRING SPECIFICATIONS**

Wire No.	Wire Color	Origin or Gauge	Length	Terminals, Connectors and 1 or 2 End Wire Preparation
1	Red	23-66-0875	-----	Component of the Switch Assembly.
2	White	23-66-0875	-----	Component of the Switch Assembly.
3	Blue	23-66-0875	-----	Component of the Switch Assembly.
4	White	23-66-0875	-----	Component of the Switch Assembly.
5	Black	23-66-0875	-----	Component of the Switch Assembly.
6	Red	14-50-0205	-----	Component of the Motor Assembly.
7	Black	14-50-0205	-----	Component of the Motor Assembly.
10	White	23-66-0875	-----	Component of the Switch Assembly.
11	Red	23-66-0875	-----	Component of the Switch Assembly.
12	Black	22-06-0130	-----	Component of the Fuel Gauge Assembly.
12	White	22-06-0130	-----	Component of the Fuel Gauge Assembly.
12	Red	22-06-0130	-----	Component of the Fuel Gauge Assembly.
12	Green	22-06-0130	-----	Component of the Fuel Gauge Assembly.
12	Brown	22-06-0130	-----	Component of the Fuel Gauge Assembly.
12	Blue	22-06-0130	-----	Component of the Fuel Gauge Assembly.

**AS AN AID TO REASSEMBLY, TAKE NOTICE OF WIRE ROUTING AND POSITION IN WIRE GUIDES AND TRAPS WHILE DISMANTLING TOOL.**

**BE CAREFUL AND AVOID PINCHING WIRES BETWEEN HANDLE HALVES WHEN ASSEMBLING.**