



SERVICE PARTS LIST

BULLETIN NO.
54-22-2601

SPECIFY CATALOG NO. AND SERIAL NO. WHEN ORDERING PARTS		REVISED BULLETIN	DATE
M18™ MULTI-TOOL		54-22-2600	Oct. 2019
CATALOG NO.	2626-20	WIRING INSTRUCTION	
STARTING SERIAL NO.	F40B	See Page Two	

EXAMPLE:
Component Parts (Small #) Are Included
When Ordering The Assembly (Large #).

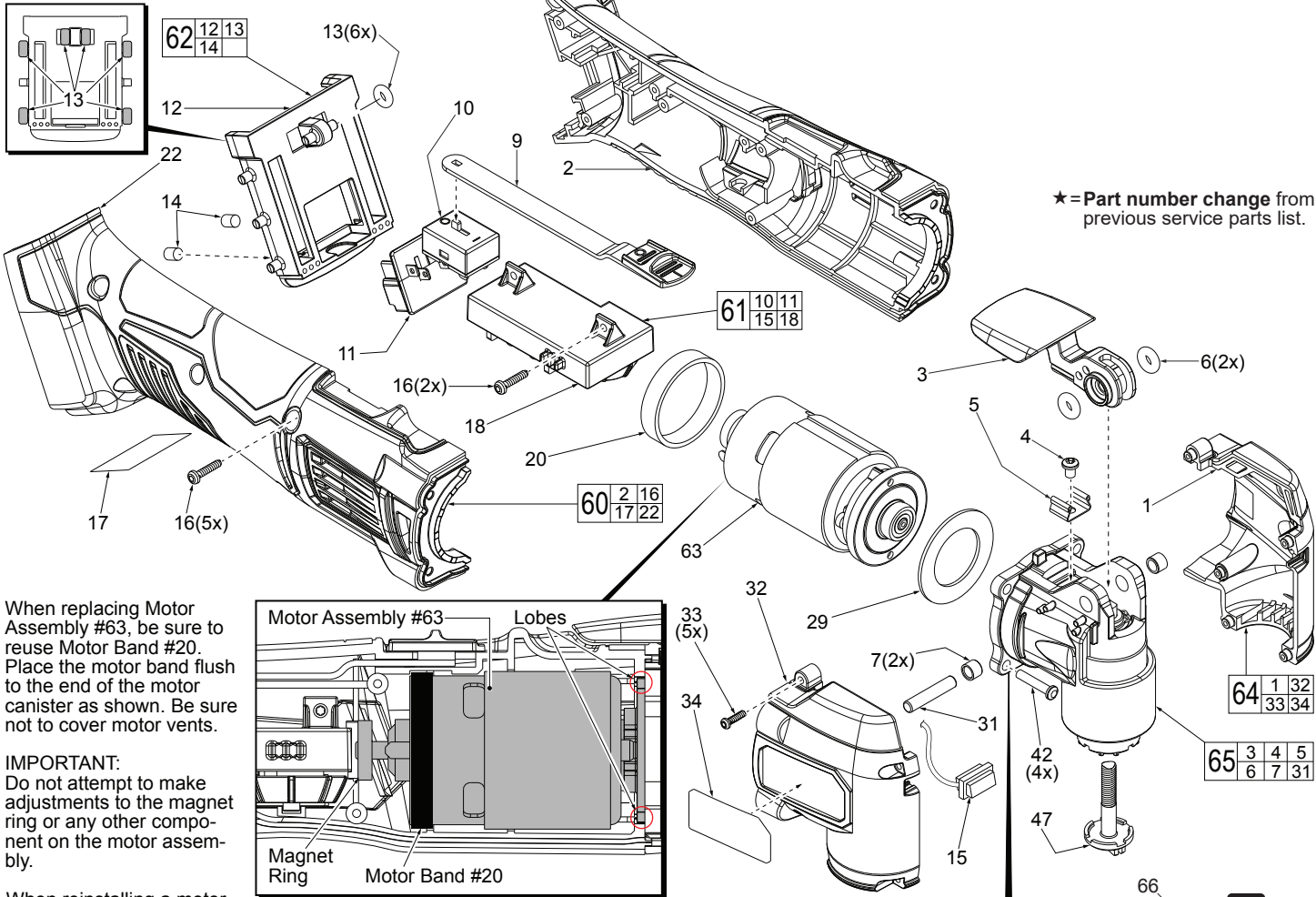

★ = Part number change from previous service parts list.

When replacing Motor Assembly #63, be sure to reuse Motor Band #20. Place the motor band flush to the end of the motor canister as shown. Be sure not to cover motor vents.

IMPORTANT:
Do not attempt to make adjustments to the magnet ring or any other component on the motor assembly.

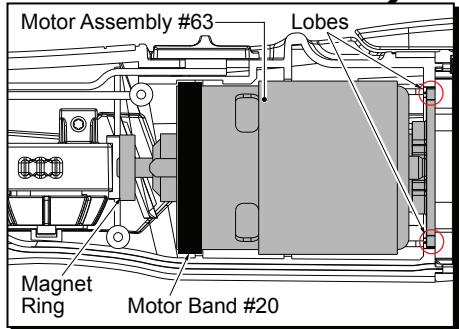

When reinstalling a motor assembly, be sure to orient the 'lobes' of the motor mount at the 12:00 and 6:00 position prior to placing the motor assembly in Left Rear Handle #2.

FIG.	PART NO.	DESCRIPTION OF PART	NO. REQ.
1	-----	Front Housing - Left	1
2	-----	Rear Handle - Left	1
3	44-10-0225	Quick Release Lever	1
4	05-88-0045	M4 x 0.7 x 8mm Pan Hd. Taptite Phillips Scr	1
5	42-70-0510	Clip	1
6	34-40-0077	Rubber O-Ring	2
7	42-40-0125	Nylon Bushing	2
9	45-24-1030	Switch Slide	1
10	-----	On-Off Switch	1
11	-----	Terminal Block	1
12	44-66-0392	Terminal Block Plate	1
13	43-86-0005	Rubber Isolators	6
14	45-30-1000	Silicone Slug	2
15	-----	LED Assembly	1
16	06-82-1080	M3 x 14mm Pan Hd. Plastite T-10 Screw	7
17	10-20-2743	Warning Label	1
18	-----	PCBA	1
20	42-16-0450	Motor Band (Rubber)	1
22	-----	Rear Handle - Right	1
29	45-88-0088	Washer	1
31	44-60-0605	5.0 x 26mm Pin	1
32	-----	Front Housing - Right	1
33	06-82-2385	M2.6 x 14mm Pan Hd. Plastite T-8 Screw	5
34	12-20-2638	Service Nameplate	1

Alternate the tightening pattern for gearcase screws #42 as shown.

Seat torque to be 19.5 in/lbs (21.5 kg/cm)

Order is 1,2,3,4 than 1,2,3,4 again

FIG.	PART NO.	DESCRIPTION OF PART	NO. REQ.
42	05-88-0400	M4 x 20mm Fillister Hd. T-20 Screw	4
47	06-75-0025	Blade/Backing Pad Screw	1
★ 60	31-44-1057	Rear Handle Assembly	1
61	14-20-2626	Switch/Electronics Assembly	1
62	14-67-0130	Terminal Block Plate Assembly	1
★ 63	14-50-0707	Motor Assembly	1
64	14-38-2000	Front Housing Assembly	1
65	14-29-2626	Gearcase Assembly	1
66	48-55-3500	Carrying Case	1



SCREW TORQUE SPECIFICATIONS

FIG.	PART NO.	WHERE USED	SEAT TORQUE	
			(KG/CM)	(IN/LBS)
4	05-88-0045	Gearcase (Top) / Clip	13±2	11.5±1.5
16	06-82-1080	Rear Handle - Right	10±2	8.5±1.5
16	06-82-1080	PCBA	10±2	8.5±1.5
33	06-82-2385	Front Housing - Right	7±1	6±1
42	05-88-0400	Gearcase (Front)	21.5±2	18.5±1.5

It is recommended to hand tighten Rear Handle Screws #16, PCBA Screws #16 and Front Housing Screws #33 to prevent over tightening. Exercise caution when tightening screws if a cordless driver drill is used.

NOTE:
Route the blue wire (from the PCBA to the negative motor terminal) behind the PCBA screw lobe. Be sure to tuck the blue wire down into the rear handle as much as possible, away from the magnet ring of the motor assembly.

It is recommended to use heat shrink tubing over the soldered wires / motor terminals as shown.

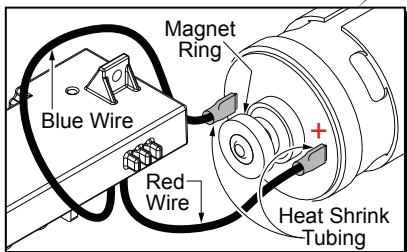

Proper orientation of the Motor Assembly #63 is with the slot in the motor canister to the top at the 12:00 position.

This rear view of the motor assembly is shown without the rubber motor band #20 in place so the slot at the top could be seen.

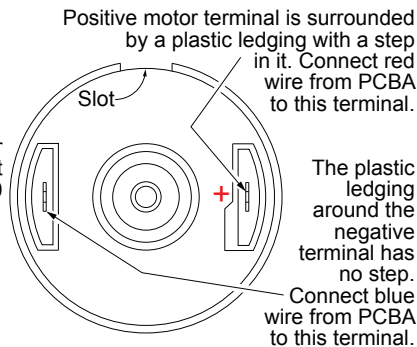

The plastic ledging around the negative terminal has no step. Connect blue wire from PCBA to this terminal.

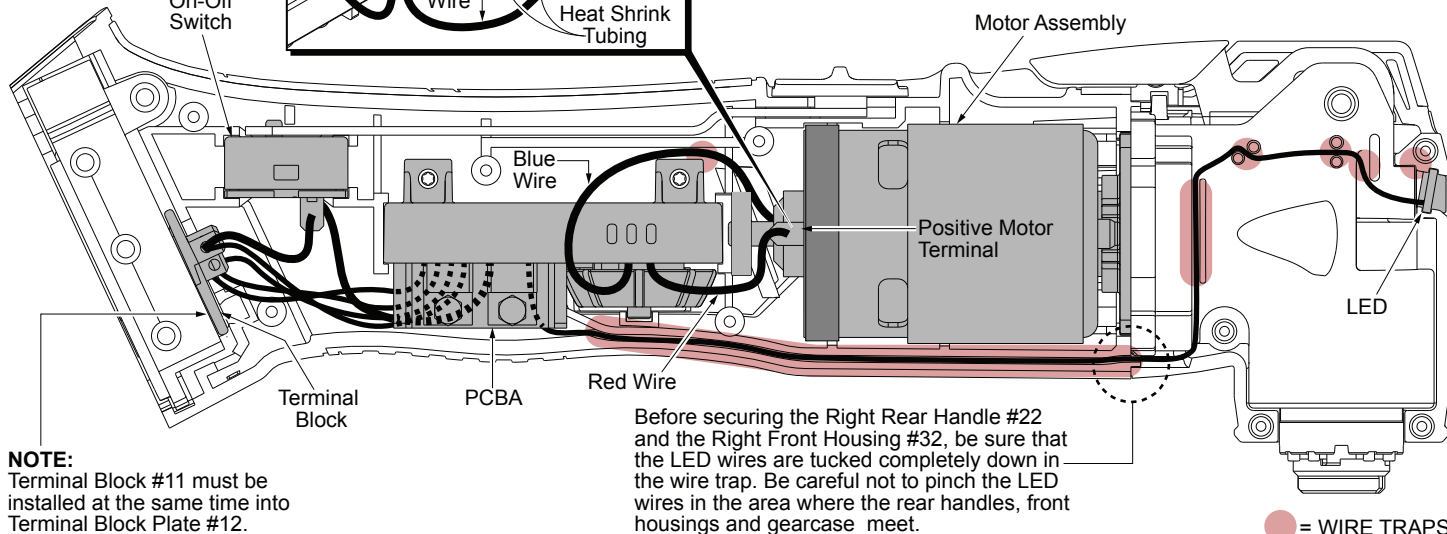

NOTE:
Terminal Block #11 must be installed at the same time into Terminal Block Plate #12.

LUBRICATION NOTES: Use Type 'J' Grease, No. 49-08-4220

When servicing, remove 90-95% of the existing grease prior to installing Type "J". Original grease maybe similar in color but not compatible with "J".

Place a light coating of grease on the metal cam portion of the Quick Release Lever #3 prior to installing on the Gearcase Assembly #65.

Place a light coating of grease on the O-Rings #6 (both sides) prior to installing in the Quick Release Lever #3.

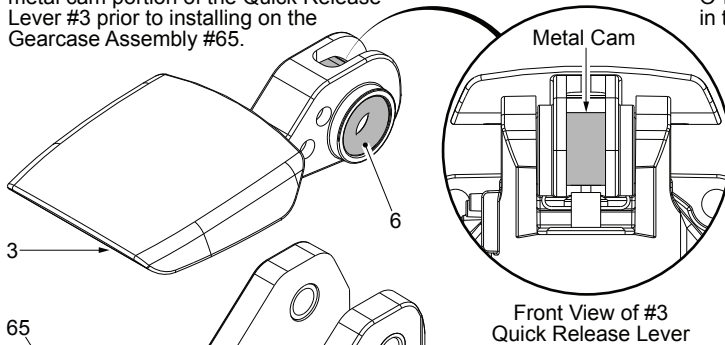

Place a light coating of grease on Metal Pin #31 prior to installing in the Gearcase Assembly #65.

Fill the inside cavity of Gearcase Assembly #65 with approximately .35oz. (10g) of grease.

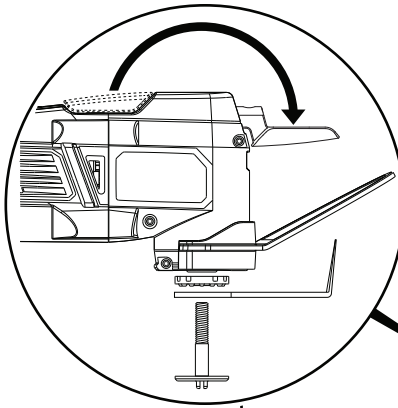

WARNING!
Always use blade installation guard when installing and removing angled blades. Blades are sharp and can cause injury.

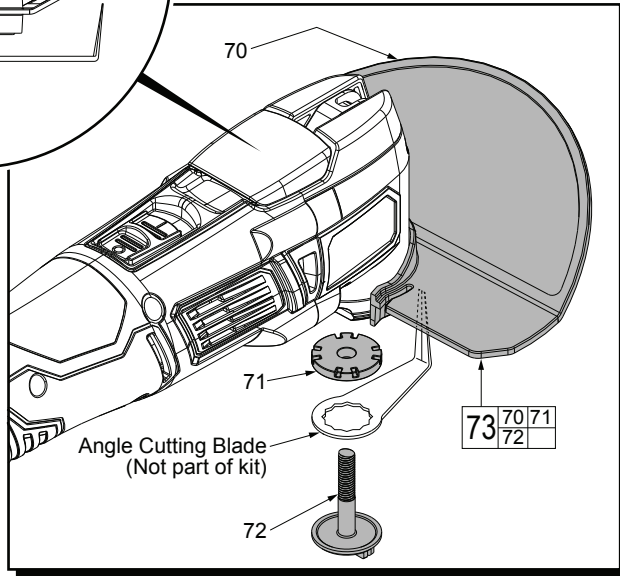

Procedure to change cutting accessories:

- 1). Remove the battery pack.
- 2). Snap the blade installation guard #70 over the neck of the tool, as shown.
- 3). Lift the quick release lever #3 and push it firmly forward over the detent.
- 4). Place the tool upside down on a flat surface.
- 5). Unscrew the accessory bolt #72.
- 6). Remove any accessories and adapter #71.

ANGLE BLADE GUARD KIT (Not a component of tool, sold separately)
No. 14-32-0300

FIG.	PART NO.	DESCRIPTION OF PART	NO. REQ.
	70	Angle Blade Guard with <u>Warning Label</u>	1
	71	Angle Blade Adapter	1
	72	Angle Blade Screw	1
	73	14-32-0300 Angle Blade Installation Guard Kit	1

Changing Accessories

1. Remove the battery pack.
2. Lift the quick release lever and push it firmly forward over the detent.
3. Place the tool upside down on a flat surface.
4. Unscrew the accessory bolt.
5. Remove any accessories and adapter.
6. Clean bolt, flange, adapter and accessories of all dirt and debris.
7. Place the adapter (if necessary), accessory and bolt onto the tool. Determine the need for an adapter by using the chart. Hand tighten securely.
8. Press the quick release lever back into place.

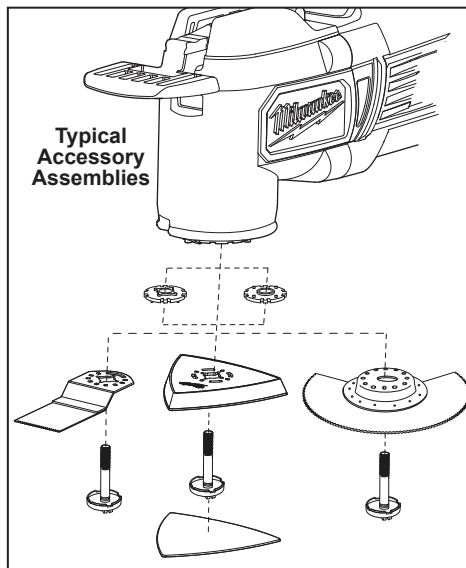
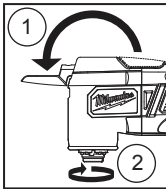

Accessory Arbor Type	Use adapter with this side facing accessory
	adapter not needed
	adapter not needed
	adapter not needed
	adapter not needed

* Adapter kit available as an accessory. Always use installation guard and accessory bolt provided with the kit when using these accessories.

ACCESSORIES

BACKING PAD
44-52-2000

BACKING PAD
44-52-2005

PLUNGE CUT WOOD BLADE
50-02-1025

BLADE ADAPTER
42-40-0155