



# SERVICE PARTS LIST

BULLETIN NO.  
54-44-2611

SPECIFY CATALOG NO. AND SERIAL NO. WHEN ORDERING PARTS		REVISED BULLETIN	DATE
<b>M18™ CORDLESS SHEARS, Double Cut Head</b>		54-44-2610	Nov. 2022
CATALOG NO. <b>2636-20</b>	STARTING SERIAL NO. <b>F87B</b>	WIRING INSTRUCTION <b>SEE PAGE 3</b>	

**EXAMPLE:**  

00	0
----	---

 Component Parts (Small #) Are Included  
 When Ordering The Assembly (Large #).



★ = Part number change  
from previous service parts list.

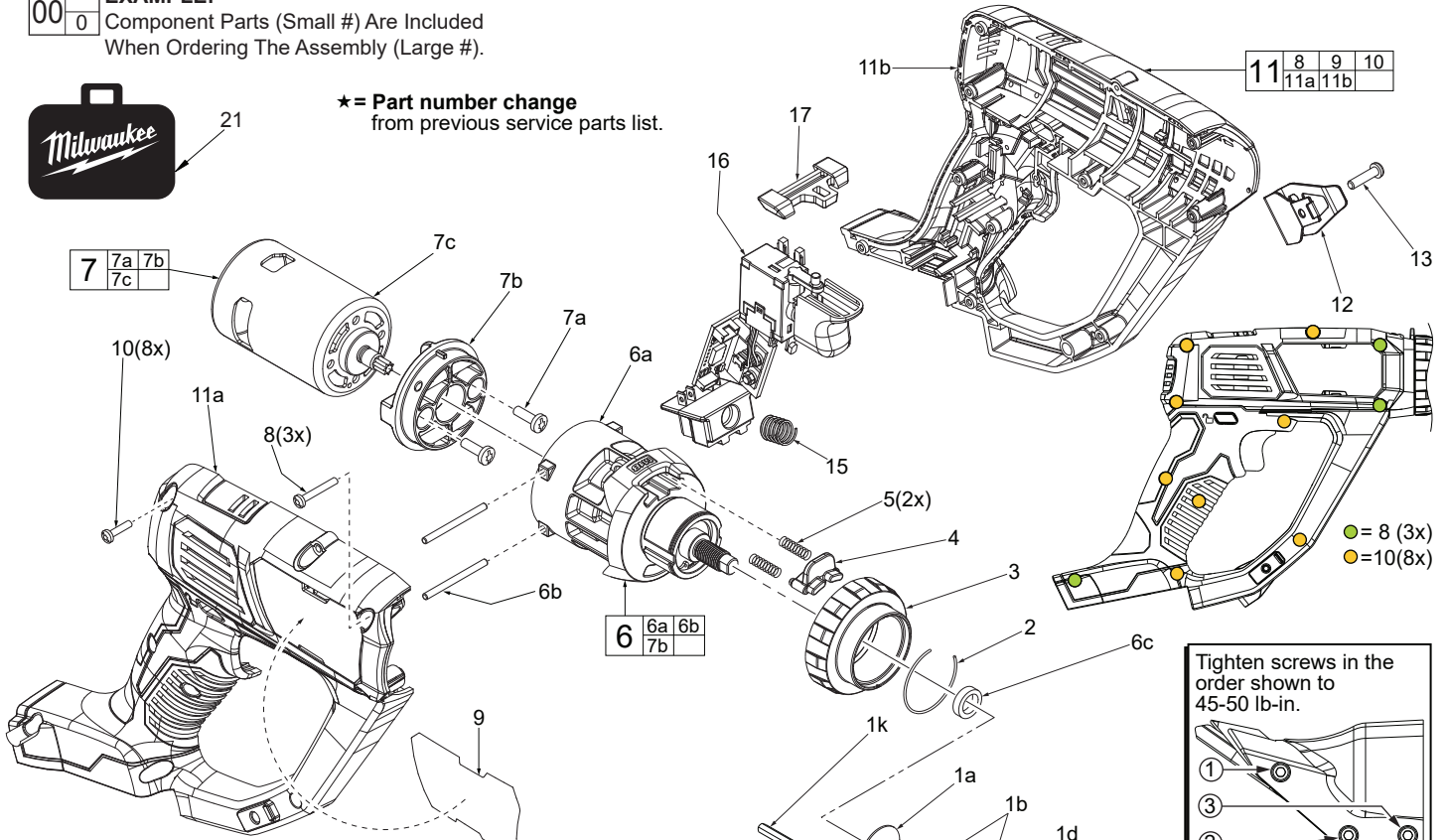
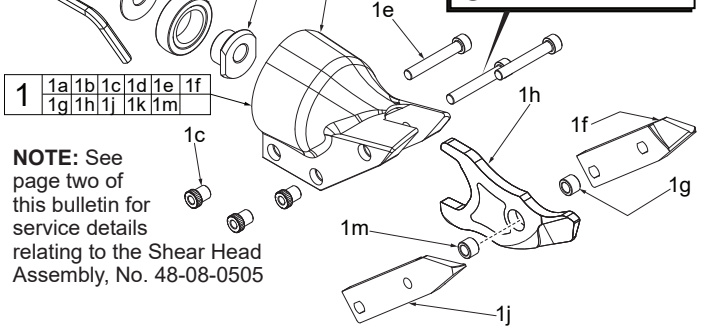

FIG.	PART NO.	DESCRIPTION OF PART	NO. REQ.
	1	Shear Head Assy. (Includes 1a thru 1m)	1
★	1a	Washer	1
	1b	Eccentric Assembly	1
★	1c	Knurled Insert	3
★	1d	Shear Housing	1
★	1e	10-32 x 1-1/4" Skt. Hd. Cap Screw	3
★	1f	Blade - Left Side	1
★	1g	Bushing	1
★	1h	Blade - Center	1
★	1j	Blade - Right Side	1
★	1k	5/32" Hex Allen Wrench	1
★	1m	Front Bushing	1
	2	'C' Retaining Ring	1
	3	Rotational Collar	1
	4	Rotational Head Release Lever	1
	5	Spring	2
	6	Gearbox Assembly	1
	6a	Gearbox	1
	6b	2.5mm x 47mm Steel Pin	2
	6c	Washer (Spacer)	1
	7	Motor Assembly	1
	7a	M5.0 x 12mm Screw	2
	7b	Motor Mount Plate	1
	7c	Motor	1
	8	M3.0 x 22.5mm Pan Hd. ST T-10 Screw	3
	9	Service Nameplate	1
	10	M3.0 x 16mm Pan Hd. ST T-10 Screw	8
	11	Handle Housing Assembly	1
	11a	Handle Halve - Right (Cover)	1
	11b	Handle Halve - Left (Support)	1
	12	Belt Clip	1
	13	6-32 x .75" Pan Hd. Phillips Machine Screw	1
	15	Compression Spring	1
	16	Electronics Assembly (Includes On-Off Switch, PCBA and Terminal Connector Block)	1
	17	Lock-Off Shuttle	1
	21	Contractors Bag	1



**NOTE:** See page two of this bulletin for service details relating to the Shear Head Assembly, No. 48-08-0505

- FIG. NOTES:**
- 1b,6a To remove the eccentric assembly (1b) from the output shaft of the gearcase (6a) a 1/4" open end wrench should be used to secure the end of the shaft. Use a thin walled 3/4" wrench to tighten/loosen the eccentric.
  - 2,3,4 When replacing Rotational Collar (3), remove 'C' Retaining Ring (2). Pull back Release Lever (4) while turning Rotational Collar (3) 90° in either direction, lining up the lugs in the Rotational Collar with the slots on the front of the Gearbox.
  - 3,4,5,6a Place a light film of Type 'E' Grease, No. 49-08-4122 to the inside diameter of the Rotational Collar (3), to the front neck of Gearbox (6a), to the underside of the Release Lever (4) and the two Release Lever Springs (5).
  - 6,7,7b Service replacement gearcase assembly (6) comes with a motor mount plate (7b) that must be removed and discarded when servicing. A motor mount plate already exists on the motor assembly (7).

## LUBRICATION NOTES:

Type 'E' Grease, No. 49-08-4122

When servicing **Shear Head Assembly No. 48-08-0505** pay close attention to the placement of the Bushings. One is to be placed in the hole of the Center Blade and is to be held in place with the front most screw on the Shear Housing. The other bushing is to be located below the small concave notch of the Center Blade and is to be secured with the middle screw on the Shear Housing. Prior to assembly, it is recommended to use Type 'E' Grease, No. 49-08-4122 on the following areas: Place a dab of grease in the pivot (bushing) hole and on the bushing notch of the Center Blade. Place a dab of grease on the rear flats of the Center Blade. Coat both bushings completely with grease. Coat both bushings completely with grease. Place a liberal amount of grease on the entire Eccentric Assembly.

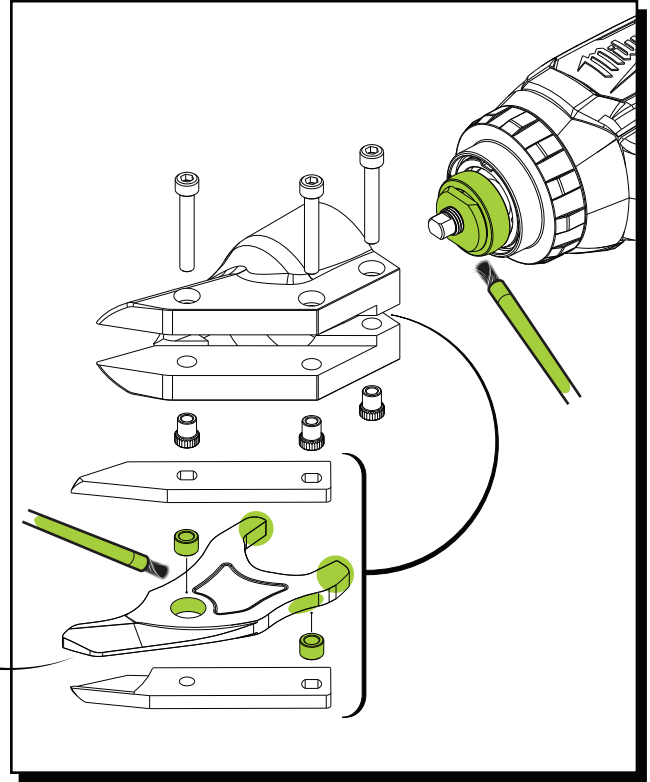
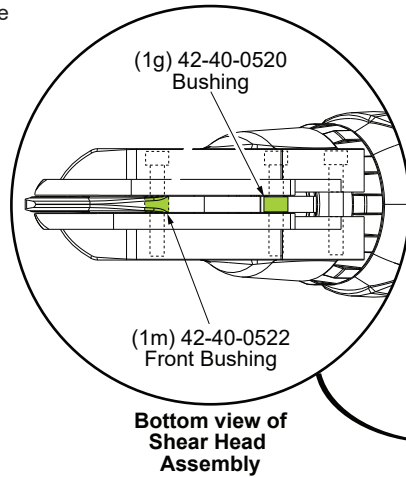

## REMOVING SHEAR HEAD ASSEMBLY FROM TOOL

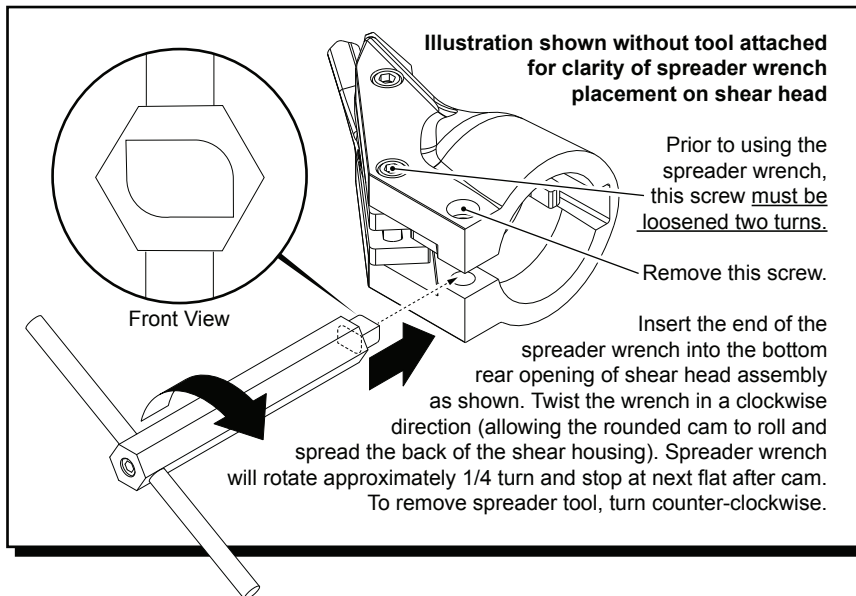

### SERVICE TOOLS:

**Spreader Wrench No. 61-30-0300**  
for 14 Gauge Shear Head 48-08-0505  
used on Shear No. 2636-20

for 18 Gauge Shear Head 48-08-0507  
used on Shear 2637-20

**Spreader Wrench No. 61-30-0310**  
for 18 Gauge Shear Head 48-08-0500  
used on Shears 2635-20 and 6852-20

## SERVICE WIRING

**Note:** Positive (+) terminal is marked with a red dot. Orient motor with the positive terminal at the 11:00 o'clock position as viewed from the back.

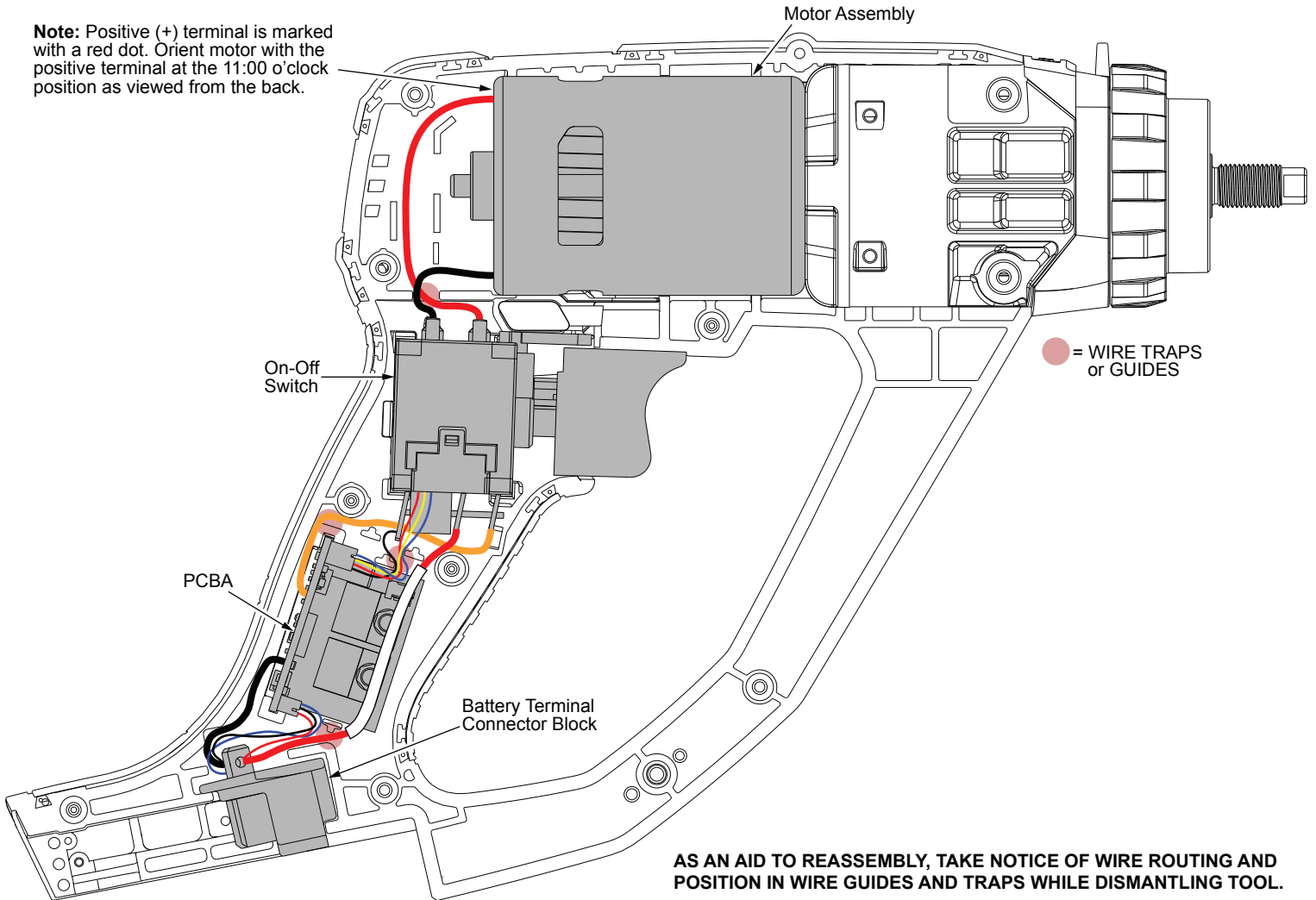

**AS AN AID TO REASSEMBLY, TAKE NOTICE OF WIRE ROUTING AND POSITION IN WIRE GUIDES AND TRAPS WHILE DISMANTLING TOOL.**

**BE SURE THAT ALL COMPONENTS OF THE ELECTRONICS KIT ARE SEATED FIRMLY AND SQUARELY IN THE HANDLE RECESSES.**

**AVOID PINCHED WIRES, BE SURE THAT ALL WIRES AND SLEEVES ARE PRESSED COMPLETELY DOWN IN WIRE GUIDES AND TRAPS.**

**PRIOR TO INSTALLING THE HANDLE COVER ONTO THE HANDLE SUPPORT, BE SURE THAT THERE ARE NO INTERFERENCES.**