

Packaged Air-Handling Units 6 to 30 Tons Overhead Suspension Accessory

Cancels: New

IHK 524A-72-2
3/15/95

Installation Instructions

Part No. CASUSPEN001A00

SAFETY CONSIDERATIONS

Installation of this accessory can be hazardous due to electrical components and equipment location (such as a ceiling or elevated structure). Only trained, qualified installers and service mechanics should install and service this equipment.

When installing this accessory, observe precautions in the literature, labels attached to the equipment, and any other safety precautions that apply.

- Follow all safety codes.
- Wear safety glasses and work gloves.
- Use care in handling and installing this accessory.

	<p>ELECTRIC SHOCK HAZARD</p> <p>To avoid the possibility of electrical shock, open and tag all disconnects before installing this equipment.</p>
---	---

INTRODUCTION

The overhead suspension accessory enables horizontal ceiling mounting of 6 to 30 ton packaged air-handling units. Each accessory kit contains 4 brackets (Fig. 1) to be

installed with field-supplied steel channels, 3/8-in. threaded hanger rod, and fasteners at 4 unit support points.

Units with hot water or steam coils that are to be mounted in horizontal ceiling installations require 2 additional support points per unit, but do not require extra overhead suspension accessory kits.

See Table 1 for accessory kit contents and required field-supplied parts.

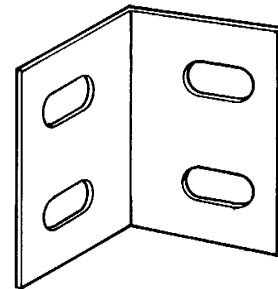

Fig. 1 — Mounting Bracket, Overhead Suspension

Table 1 — Accessory Kit Usage

UNIT SIZES	FIELD-SUPPLIED PARTS REQUIRED*	ACCESSORY KIT CONTENTS
6 to 10 Tons	2—14-gage steel channel, 56-in. length	4—Mounting Brackets 4—1/4-20 Self-Drilling Screws 1—Instructions
	4—3/8-in. threaded steel rod, required length	
	8—3/8-in. nut	
	8—3/8-in. lock washer	
	8—3/8-in. flat washer	
12½ to 20 Tons	2—12-gage steel channel, 96-in. length	
	4—3/8-in. threaded steel rod, required length	
	8—3/8-in. nut	
	8—3/8-in. lock washer	
	8—3/8-in. flat washer	
25 and 30 Tons	2—12-gage steel channel, 106-in. length	
	4—3/8-in. threaded steel rod, required length	
	8—3/8-in. nut	
	8—3/8-in. lock washer	
	8—3/8-in. flat washer	

*Parts required for minimum of 4 support points per unit. Additional support points and field-supplied hardware are required for units with hot water or steam coils. If vibration isolation is required, spring isolators must also be field-supplied.

Manufacturer reserves the right to discontinue, or change at any time, specifications or designs without notice and without incurring obligations.

INSTALLATION

Complete Pre-Installation Checks — Remove accessory packaging and inspect shipment for damage. File claim with shipping company if accessory is damaged or incomplete.

Prepare Unit for Installation — See Fig. 2 for typical horizontal ceiling installations, and prepare unit as follows:

1. Make all coil refrigerant or chilled water connections and pipe to stubs outside of unit. Install other unit accessories (hot water coil, steam coil, plenum, return-air grille, electric heat, economizer) on the unit if applicable. Follow the instructions supplied with the additional accessories.
2. With unit oriented horizontally on floor, remove a screw from the outer bottom corner of each side of the unit (4 total); retain screws.
3. Using the screws removed in Step 1, attach the mounting brackets (Fig. 1) to the unit. Use the outer slot in each bracket as shown in details A and B in Fig. 2. Tighten all screws.
4. Place unit on field-supplied channels. Align mounting brackets with channels and center unit and brackets lengthwise on channels.
5. Using supplied ¼-in. self-drilling screws, attach bottom tabs of mounting brackets to channels.
6. As shown in Detail A, Fig. 2, drill 7/16-in. hole in center of each protruding channel end approximately 3 in. out from the side of the unit.
7. Install threaded hanger rods of the desired length through holes drilled in previous step. See Detail B, Fig. 2. Attach rod to inside of channel using field-supplied 3/8-in. nut, lock washer, and flat washer.

NOTE: A unit with a hot water or steam coil requires 2 additional support points. Mounting brackets are not required, but an additional channel, 2 rods, and fasteners must be supplied and installed according to Fig. 2 and Steps 6 and 7 in the preceding instructions.

Prepare Ceiling for Installation — When selecting ceiling location for installation, ensure that ceiling can support unit weight and that service clearance requirements are met as stated in base unit installation instructions. Prepare ceiling as follows:

1. Lay out and bore four 7/16-in. diameter holes in the ceiling; see Fig. 3 for mounting pattern.
2. If the ceiling beams run parallel to the sides of the unit, bore 2 holes in each 2-in. x 4-in. beam as noted in Fig. 3 for parallel beam dimension.
3. If the ceiling beams run perpendicular to the sides of unit, bore 2 holes in each 2-in. x 4-in. beam as noted in Fig. 3 for perpendicular beam dimension.

NOTE: Unit 2-in. x 4-in. beams must run across ceiling beams to distribute weight evenly.

NOTE: Unit with hot water or steam coil requires 2 additional support points. When laying out mounting holes in ceiling, holes for additional support points should be bored approximately 9 in. (229 mm) from nearest base unit support points on the end of the unit with the coil. See Fig. 2.

Suspend Unit — Rig or support the unit in the installation location according to the installation instructions supplied with the base unit. Refer to Fig. 2 and perform the following steps:

1. Lift unit so support rods protrude through holes in ceiling and through support beams on the other side.
2. Using field-supplied 3/8-in. flat washers, lock washers, and nuts, fasten each threaded hanger rod to the top of a support beam or to the top of vibration isolators placed on the support beam. See Fig. 2, 4, and 5.
3. Level unit by screwing hanger rods into nuts as required. Do not pitch unit for condensate drainage; drain pan has a separate pitch adjustment.
4. Finish installing unit by making piping connections and electrical connections as described in the base unit installation instructions.

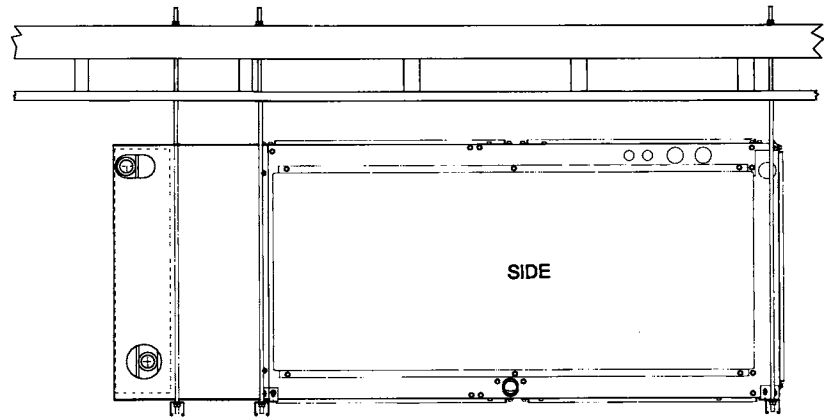
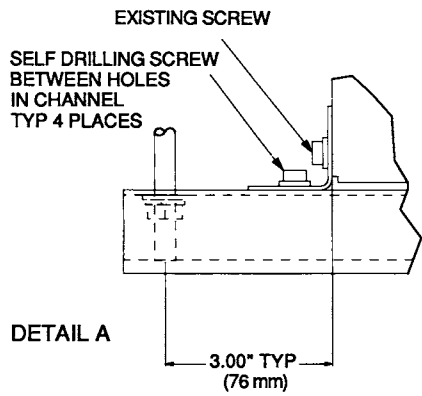
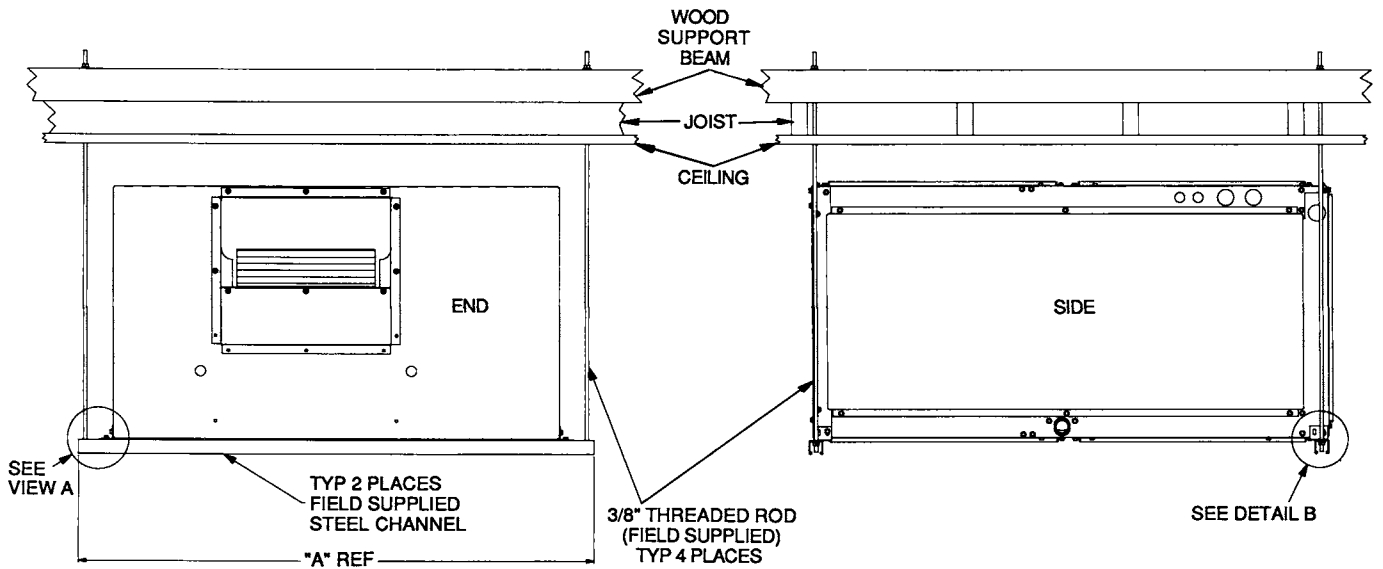

OVERHEAD SUSPENSION ACCESSORY WITH HOT WATER COIL

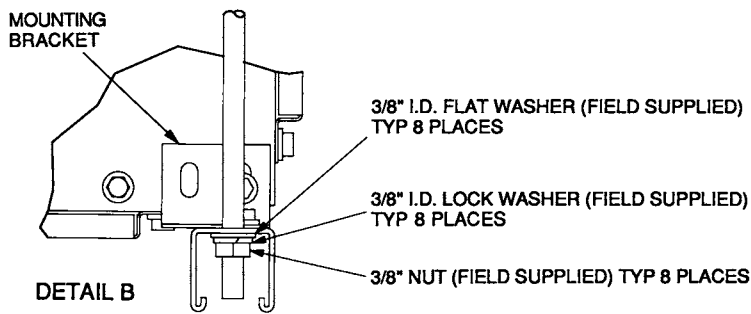

UNIT SIZES	"A"-in. (mm)
6 to 10 Tons	56 (1422)
12½ to 20 Tons	96 (2438)
25 and 30 Tons	106 (2692)

Fig. 2 – Overhead Suspension (Single-Fan Unit Shown)

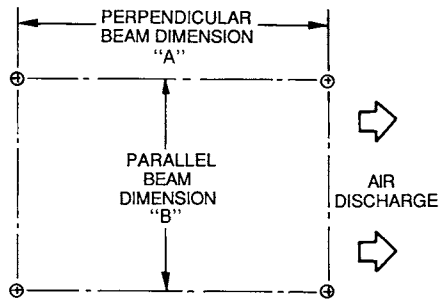

UNIT SIZES	"A"—in. (mm)	"B"—in. (mm)
6 to 10 Tons	55 (1397)	54 (1372)
12½ to 20 Tons	55 (1397)	94 (2388)
25 and 30 Tons	64 (1626)	104 (2642)

Fig. 3 – Layout of Mounting Holes in Ceiling (Typical)

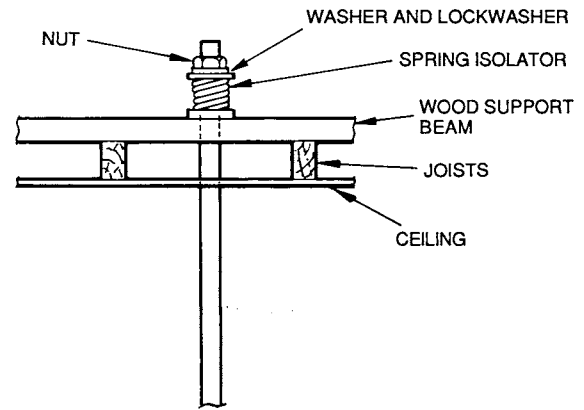

Fig. 5 – Fastening Hanger Rods to Ceiling (Vibration Isolation Applied)

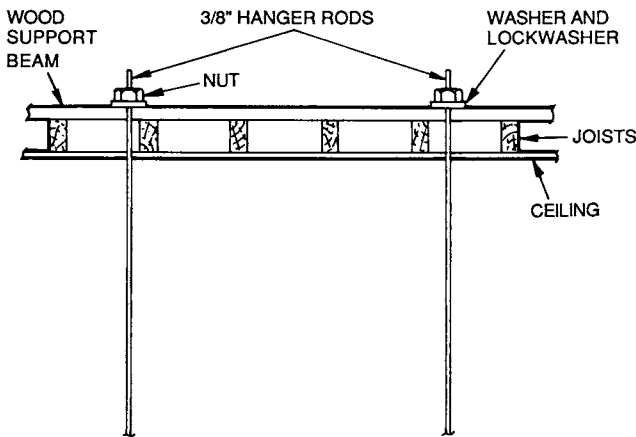

Fig. 4 – Fastening Hanger Rods to Ceiling