Zone Valve, Electric Actuator, Thermic Actuator Assembly Selection



Description

This Technical Bulletin aids in selecting a 599 Series Zone Valve and an electronic actuator or Thermic actuator assembly.

Figure 1 provides a graph of water capacity for selecting the proper valve size. Tables 1, 2 and 3 provide maximum water capacity and close-off pressures for assistance in the selection of a valve and actuator according to specifications.

Tables 4 and 5 identify the electronic actuator/valve assembly product numbers. Table 9 identifies the Thermic actuator/valve assembly product numbers. The tables show all possible combinations of Zone Valves and compatible actuators that can be ordered as complete valve/actuator assemblies from the factory.

Table 6 contains the dimensions of all valves. Tables 7, 8 and 10 provide the dimensions and service envelopes required for each valve/actuator assembly.

Using the Valve and Actuator Selection Graph

Use Figure 1, the Water Capacity Graph, to select a valve size as follows:

1. Locate the specified flow rate on the vertical axis.
2. Follow across on the horizontal axis to the point of intersection with the specified pressure drop.
3. Choose the valve size from the heavy diagonal lines across the graph.

See Table 3 to find the close-off pressures for valves relative to their size.

Using the Valve and Actuator Assembly Tables

Use the Product Number Tables 4, 5 and 9 to select a valve and actuator assembly as follows:

Read the tables from left to right and select the appropriate valve specifications to identify the row with the required valve body.

1. Read across the top of the tables and select the appropriate actuator specifications to identify the column with the required actuator.
2. Read down the actuator column and read across the valve body row. The column/row intersection determines the appropriate valve and actuator assembly. The valve and actuator assembly product number is the actuator prefix code added to the valve body suffix.

Selection Examples

In an ANSI 125 piping system, a two-way, normally closed, female-by-female, NPT threaded valve delivers 6 gpm (0.52 m³/hr) chilled water with no more than 6-psi (41.4 kPa) pressure drop across the fully open valve.

Specifications

The actuator is to receive 120 Vac power; accept a two-position control signal, and provide normally closed operation. The actuator closes off tightly against a pump head pressure of 14.5 psi (100 kPa, 1 bar).

Valve Sizing

See Figure 1, the Water Capacity Graph, to select the valve size as follows:

1. Locate the required flow rate by finding gpm (m³/hr) on the vertical axis①.
2. Follow across the horizontal axis and find the psi (kPa) maximum allowable pressure drop across the open valve②.
3. Select the valve line size that will ensure proper flow③.

Assembly**(Product Number)****Selection: An Example**

Use Table 4 to select a valve and actuator assembly as follows:

1. Read the table from left to right and select a NPT connection. Select a 0.50-inch (15 mm), 2.5 Cv (2.0 Kvs) valve. The valve body part number is 599-00211.
2. Read across the top of the table and select a normally closed, 120 Vac actuator prefix code. The prefix number is 240.
3. Read down the SFA11U actuator column and across the 0.50-inch (15 mm) valve body row to select 240-00211. The column/row intersection determines the appropriate valve and actuator assembly.

Alternatively, the valve and actuator can be ordered separately.

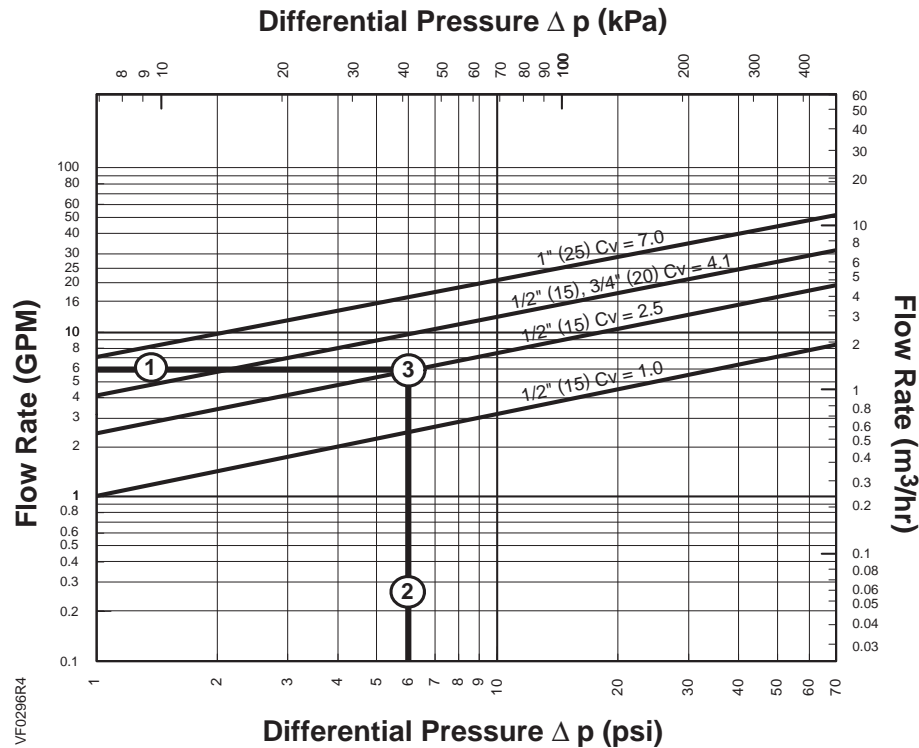

Figure 1. Water Capacity Graph.

Table 1. Maximum Water Capacity - U.S. Gallons per Minute (AB→A).

Valve Size Inches	Pressure Differential - psi															
	Cv\1	2	3	4	5	6	8	10	15	20	25	30	40	50	60	75
.50	1.0	1.4	1.7	2.0	2.2	2.4	2.8	3.2	3.9	4.4	5.0	5.5	6.3	7.1	7.7	8.7
.50	2.5	3.5	4.3	5.0	5.6	6.1	7.1	7.9	9.7	11.2	12.5	13.7	15.8	17.7	19.4	22.0
.50/.75	4.1	5.7	7.1	8.2	9.2	10.0	11.6	13.0	15.9	18.3	20.5	22.4	25.9	29.0	31.8	35.5
1.00	7.0	9.9	12.1	14.0	15.6	17.1	19.8	22.1	27.1	31.3	35.0	38.3	44.3	49.5	54.2	60.6

Table 2. Maximum Water Capacity - Cubic Meters per Hour (m³/hr) (AB→A).

Valve Size Mm	Pressure Differential - kPa														
	1	10	20	30	40	50	60	80	Kvs/ 100	150	200	300	400	500	
15	0.9	0.27	0.38	0.47	0.54	0.60	0.66	0.76	0.85	1.04	4.20	1.47	1.70	1.90	
15	0.21	0.68	0.96	1.17	1.35	1.51	1.66	1.91	2.15	2.60	3.00	3.70	4.30	4.80	
15/20	0.35	1.12	1.59	1.94	2.24	2.51	2.75	3.17	3.50	4.34	5.01	6.14	7.09	7.93	
25	0.60	1.91	2.71	3.32	3.83	4.28	4.69	5.41	6.00	7.41	8.56	10.48	12.11	13.54	

Table 3.
SFx Series, SSx Series and STx Series Close-Off Pressures.

Valve Size Inch (mm)	Pressure psi (kPa)
.50 (15)	44 (303)
.75 (20)	44 (303)
1.00 (25)	22 (152)

Table 4. Product Numbers: 2-Way Zone Valve/Electric Actuator Assemblies.

Connection	Line Size				Flow Rate		120 Vac		24 Vac				
							Fail Safe (SR)		Fail Safe (SR)		Fail-in-Place		
	2-Position		2-Position		3-Position	0 to 10 Vdc Modulating							
	Normally Closed	Normally Open	Normally Closed	Normally Open	Normally Closed	Normally Closed	Normally Open						
	SFA11U Actuator Code 240	SFP11U Actuator Code 241	SFA71U Actuator Code 242	SFP71U Actuator Code 243	SSA81U Actuator Code 244	SSA61U Actuator Code 245	SSP61U Actuator Code 248						
Inch	Mm	Cv	Kvs	Valve Body									
NPT	.50	15	1.0	0.85	599-00210	240-00210	241-00210	242-00210	243-00210	244-00210	245-00210	248-00210	
	.50	15	2.5	2.0	599-00211	240-00211	241-00211	242-00211	243-00211	244-00211	245-00211	248-00211	
	.50	15	4.0	3.4	599-00214	240-00214	241-00214	242-00214	243-00214	244-00214	245-00214	248-00214	
	.75	20	4.1	3.5	599-00212	240-00212	241-00212	242-00212	243-00212	244-00212	245-00212	248-00212	
	1.00	25	7.0	6.0	599-00213	240-00213	241-00213	242-00213	243-00213	244-00213	245-00213	248-00213	
Sweat	.50	15	1.0	0.85	599-00510	240-00510	241-00510	242-00510	243-00510	244-00510	245-00510	248-00510	
	.50	15	2.5	2.0	599-00511	240-00511	241-00511	242-00511	243-00511	244-00511	245-00511	248-00511	
	.50	15	4.0	3.4	599-00514	240-00514	241-00514	242-00514	243-00514	244-00514	245-00514	248-00514	
	.75	20	4.1	3.5	599-00512	240-00512	241-00512	242-00512	243-00512	244-00512	245-00512	248-00512	
	1.00	25	7.0	6.0	599-00513	240-00513	241-00513	242-00513	243-00513	244-00513	245-00513	248-00513	

NOTE: For more information, see *Technical Instructions* (155-320P25).

Table 5. Product Numbers: 3-Way Diverting Zone Valves /Electric Valve Assemblies.

Connection	Line Size				Flow Rate AB→A		120 Vac		24 Vac				
							2-Position		2-Position		3-Position	0 to 10 Vdc Modulating	
	Fail AB▶B	Fail AB▶A	Fail AB▶B	Fail AB▶A	Fail-In-Place								
	SFA11U Actuator Code 240	SFP11U Actuator Code 241	SFA71U Actuator Code 242	SFP71U Actuator Code 243	SSA81U Actuator Code 244	SSA61U Actuator Code 245	SSP61U Actuator Code 248						
	Inch	Mm	Cv	Kvs	Valve Body								
NPT	.50	15	1.0	0.85	599-00230	240-00230	241-00230	242-00230	243-00230	244-00230	245-00230	248-00230	
	.50	15	2.5	2.0	599-00231	240-00231	241-00231	242-00231	243-00231	244-00231	245-00231	248-00231	
	.50	15	4.0	3.4	599-00234	240-00234	241-00234	242-00234	243-00234	244-00234	245-00234	248-00234	
	.75	20	4.1	3.5	599-00232	240-00232	241-00232	242-00232	243-00232	244-00232	245-00232	248-00232	
	1.00	25	7.0	6.0	599-00233	240-00233	241-00233	242-00233	243-00233	244-00233	245-00233	248-00233	
Sweat	.50	15	1.0	0.85	599-00530	240-00530	241-00530	242-00530	243-00530	244-00530	245-00530	248-00530	
	.50	15	2.5	2.0	599-00531	240-00531	241-00531	242-00531	243-00531	244-00531	245-00531	248-00531	
	.50	15	4.0	3.4	599-00534	240-00534	241-00534	242-00534	243-00534	244-00534	245-00534	248-00534	
	.75	20	4.1	3.5	599-00532	240-00532	241-00532	242-00532	243-00532	244-00532	245-00532	248-00532	
	1.00	25	7.0	6.0	599-00533	240-00533	241-00533	242-00533	243-00533	244-00533	245-00533	248-00533	

NOTE: For more information, see *Technical Instructions* (155-320P25).

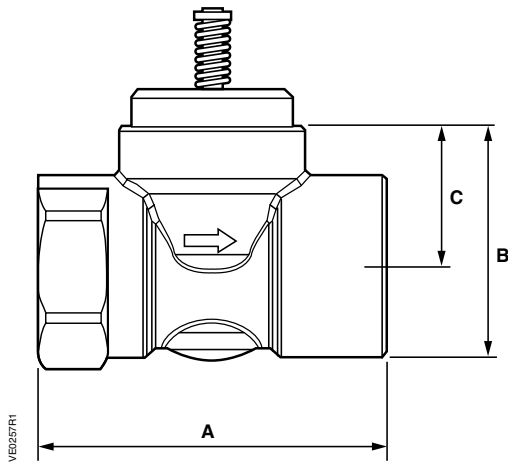

Figure 2. 2-Way Zone Valve, Normally Open.

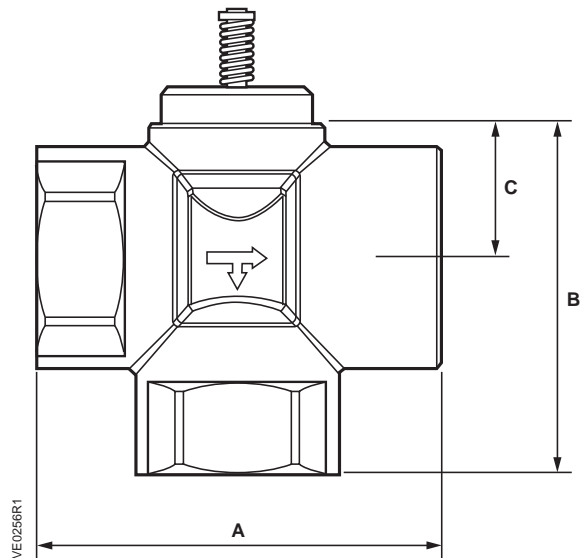
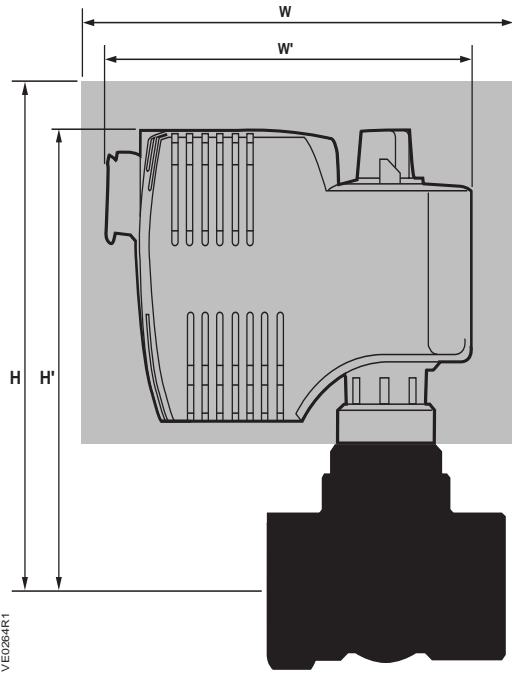

Figure 3. 3-Way Diverting Zone Valve.

Table 6. Valve Dimensions.

Connection Type	Valve Size Inch (mm)	2-Way Valve				3-Way Valve			
		A	B	C	Weight lb. (kg)	A	B	C	Weight lb (kg)
NPT	.50 (15)	2.76 (70)	1.63 (41)	.96 (24)	0.82 (0.37)	2.76 (70)	2.34 (60)	.96 (24)	1.08 (0.49)
	.75 (20)	2.76 (70)	1.77 (45)	.96 (24)	.99 (0.45)	2.76 (70)	2.34 (60)	.96 (24)	1.26 (0.57)
	1.0 (25)	3.50 (89)	2.34 (59)	.96 (24)	1.68 (0.76)	3.50 (89)	3.03 (77)	.96 (24)	2.14 (0.97)
Sweat	.50 (15)	2.66 (66)	1.48 (38)	.96 (24)	0.60 (0.27)	2.66 (66)	2.26 (58)	.96 (24)	0.71 (0.32)
	.75 (20)	2.76 (70)	1.63 (41)	.96 (24)	0.71 (0.32)	2.76 (70)	2.34 (60)	.96 (24)	0.86 (0.39)
	1.00 (25)	3.50 (89)	1.77 (45)	.96 (24)	1.06 (0.48)	3.50 (89)	2.65 (67)	.96 (24)	1.24 (0.6)



VED0264R1

**Figure 4. SFA/P Series Actuator:
 Service Envelope for 2-Way Valve Assembly.**

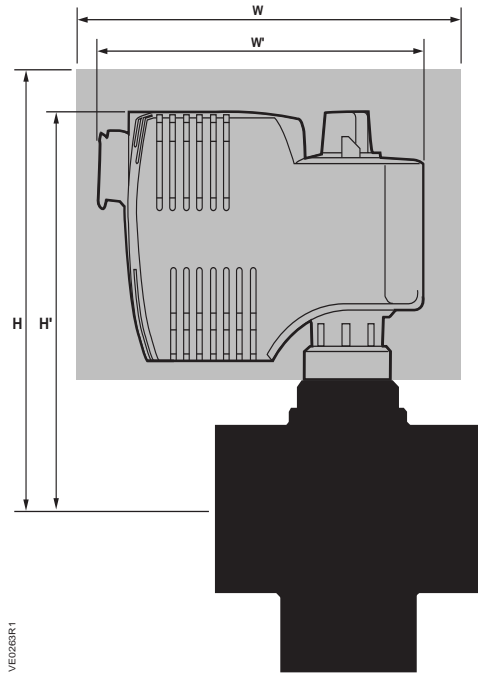

VED0268R1

**Figure 5. SFA/P Series Actuator:
 Service Envelope for 3-Way Valve Assembly.**

Table 7. SFA/P Actuator Dimensions and Recommended Service Envelope in Inches (Millimeters).

Actuator	Actuator Prefix Codes	Valve Line Size	Valve Centerline to Top of Actuator H1		Service Height H		Width or Diameter of Actuator W1		Service Width W	
			2-Way	3-Way	2-Way	3-Way	2-Way	3-Way	2-Way	3-Way
Fail-Up/ Fail-Down	240 241 242 243	.50 (15)	4.38 (112)	4.38 (112)	12.38 (315)	12.38 (315)	4.38 (112)	4.38 (112)	12.38 (315)	12.38 (315)
		.75 (20)	4.38 (112)	4.38 (112)	12.38 (315)	12.38 (315)	4.38 (112)	4.38 (112)	12.38 (315)	12.38 (315)
		1.00 (25)	4.38 (112)	4.38 (112)	12.38 (315)	12.38 (315)	4.38 (112)	4.38 (112)	12.38 (315)	12.38 (315)

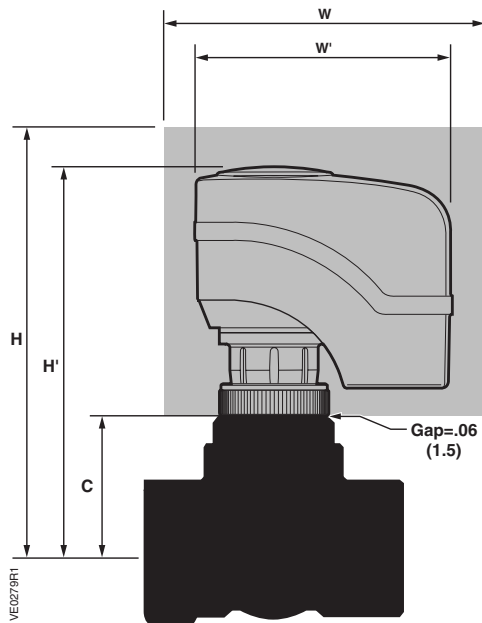

Figure 6. SSA/P Series Actuator: Service Envelope for 2-Way Valve Assembly.

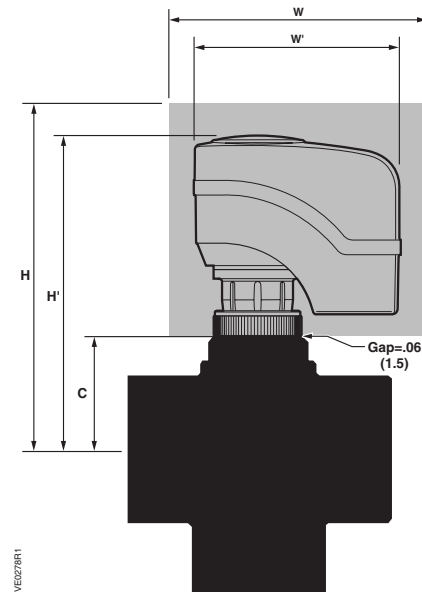

Figure 7. SSA/P Series Actuator: Service Envelope for 3-Way Service Envelope.

Table 8. SSA/P Actuator Dimensions and Recommended Service Envelope in Inches (Millimeters).

Actuator Prefix Codes	Valve Line Size	Valve Centerline to Top of Actuator H1		Service Height H		Valve Centerline to Actuator Coupling C		Width or Diameter of Actuator W1		Service Width W	
		2-Way	3-Way	2-Way	3-Way	2-Way	3-Way	2-Way	3-Way	2-Way	3-Way
244	.50 (15)	4.26 (108)	4.26 (108)	12.26 (311)	12.26 (311)	1.00 (25)	1.00 (25)	3.26 (83)	3.26 (83)	11.26 (286)	11.26 (286)
245	.75 (20)	4.26 (108)	4.26 (108)	12.26 (311)	12.26 (311)	1.00 (25)	1.00 (25)	3.26 (83)	3.26 (83)	11.26 (286)	11.26 (286)
248	1.00 (25)	4.26 (108)	4.26 (108)	12.26 (311)	12.26 (311)	1.00 (25)	1.00 (25)	3.26 (83)	3.26 (83)	11.26 (286)	11.26 (286)

Thermic Actuator

Table 9. Product Numbers: 2-Way and 3-Way Zone Valve/Thermic Actuator Assemblies..

Connection		Line Size		Flow Rate		Valve Body	24 Vac			
							2-Position			
		Normally Closed		Normally Open			Fail AB▶ B	Fail AB▶ A		
		STA71	STP71	STA71	STP71		Actuator Code 246	Actuator Code 247		
Inch	Mm	Cv	Kvs		Actuator Code 246	Actuator Code 247	Actuator Code 246	Actuator Code 247		
2-way	NPT	.50	15	1.0	.85	599-00210	246-00210	247-00210	—	—
		.50	15	2.5	2.0	599-00211	246-00211	247-00211	—	—
		.50	15	4.0	3.4	599-00214	246-00214	247-00214	—	—
		.75	20	4.1	3.5	599-00212	246-00212	247-00212	—	—
		1.00	25	7.0	6.0	599-00213	246-00213	247-00213	—	—
	Sweat	.50	15	1.0	.85	599-00510	246-00510	247-00510		
		.50	15	2.5	2.0	599-00511	246-00511	247-00511	—	—
		.50	15	4.0	3.4	599-00514	246-00514	247-00514		
		.75	20	4.1	3.5	599-00512	246-00512	247-00512	—	—
		1.00	25	7.0	6.0	599-00513	246-00513	247-00513	—	—
3-Way	NPT	.50	15	1.0	.85	599-00230	—	—	246-00230	247-00230
		.50	15	2.5	2.0	599-00231	—	—	246-00231	247-00231
		.50	15	4.0	3.4	599-00234	—	—	246-00234	247-00234
		.75	20	4.1	3.5	599-00232	—	—	246-00232	247-00232
		1.00	25	7.0	6.0	599-00233	—	—	246-00233	247-00233
	Sweat	.50	15	1.0	.85	599-00530	—	—	246-00530	247-00530
		.50	15	2.5	2.0	599-00531	—	—	246-00531	247-00531
		.50	15	4.0	3.4	599-00534	—	—	246-00534	247-00534
		.75	20	4.1	3.5	599-00532	—	—	246-00532	247-00532
		1.00	25	7.0	6.0	599-00533	—	—	246-00533	247-00533

Dimensions

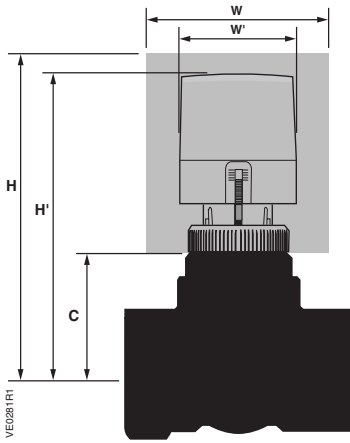

Figure 8. Thermic Actuator: 2-Way Valve Assembly Service Envelope.

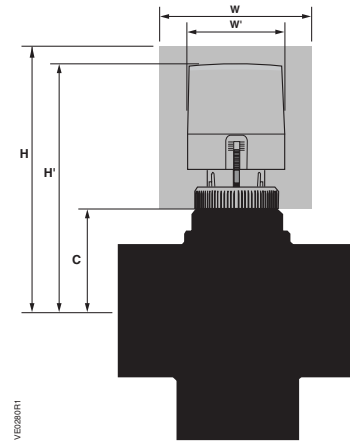

Figure 9. Thermic Actuator: 3-Way Valve Assembly Service Envelope.

Table 10. STA/P Thermic Actuator Dimensions and Recommended Service Envelope in Inches (Millimeters).

Valve Line Size	Valve Centerline to Top of Actuator H ¹		Service Height H		Valve Centerline to Actuator Coupling C		Width or Diameter of Actuator W ¹		Service Width W	
	2-Way	3-Way	2-Way	3-Way	2-Way	3-Way	2-Way	3-Way	2-Way	3-Way
0.5 (15)	3.44 (87)	3.44 (87)	7.44 (189)	7.44 (189)	1.00 (25)	1.00 (25)	1.71 (43.5)	1.71 (43.5)	9.86 (251)	9.86 (251)
0.75 (20)	3.44 (87)	3.44 (87)	7.44 (189)	7.44 (189)	1.00 (25)	1.00 (25)	1.71 (43.5)	1.71 (43.5)	9.86 (251)	9.86 (251)
1.00 (25)	3.44 (87)	3.44 (87)	7.44 (189)	7.44 (189)	1.00 (25)	1.00 (25)	1.71 (43.5)	1.71 (43.5)	9.86 (251)	9.86 (251)

Information in this publication is based on current specifications. The company reserves the right to make changes in specifications and models as design improvements are introduced. Other product or company names mentioned herein may be the trademarks of their respective owners.
 ©2005 Siemens Building Technologies, Inc.