

**CRPHASE3001A02
CRPHASE3002A00
CRPHASE3002A01**

**Split Systems, 6 to 20 Tons (21.5 to 70.3 kW)
Rooftop Units, 3 to 27.5 Tons (10.5 to 96.7 kW)
Packaged Heat Pumps
Phase Monitor Accessory
50/60 Hz**

Installation Instructions

TABLE OF CONTENTS

PACKAGE CONTENTS	1
SAFETY CONSIDERATIONS	1
GENERAL	1
Phase Reversal Protection	2
Phase Loss Protection	2
INSTALLATION	2
Install Phase Monitor	2
For R-410A Units	3

IMPORTANT: Read these instructions completely before attempting to install the accessory.

PACKAGE CONTENTS

CRPHASE3001A02 (208/230V and 460V)

QTY	CONTENTS
1	Phase Monitor Part No. HK35AC003
1	Installation Instructions
4	6B – 20 x 3/4 LG screws
1	Harness Assembly

PACKAGE CONTENTS

CRPHASE3002A00 (575V)

QTY	CONTENTS
1	Phase Monitor Part No. 48HG503588
1	Installation Instructions
4	6B – 20 x 3/4 LG screws
1	Harness Assembly

SAFETY CONSIDERATIONS

Installation and servicing of air-conditioning equipment can be hazardous due to system pressure and electrical components. Only trained and qualified service personnel should install, repair, or service air-conditioning equipment.

Untrained personnel can perform the basic maintenance functions. All other operations should be performed by trained service personnel. When working on air-conditioning equipment, observe precautions in the literature, tags and labels attached to the unit, and other safety precautions that may apply.

Follow all safety codes. Wear safety glasses and work gloves.

Recognize safety information. This is the safety-alert symbol . When you see this symbol on the unit and in instructions or manuals, be alert to the potential for personal injury.

Understand the signal words DANGER, WARNING, and CAUTION. These words are used with the safety-alert symbol. DANGER identifies the most serious hazards which **will** result in severe personal injury or death. WARNING signifies a hazard which **could** result in personal injury or death. CAUTION is used to identify unsafe practices which **may** result in minor personal injury or product and property damage. NOTE is used to highlight suggestions which **will** result in enhanced installation, reliability, or operation.

WARNING

ELECTRICAL SHOCK HAZARD

Failure to follow this warning could result in personal injury and/or death.

Before performing service or maintenance operations on unit, turn off main power switch to unit. If gas unit, shut off gas supply *before* shutting off main power. TAG DISCONNECT SWITCH WITH A SUITABLE WARNING LABEL.

GENERAL

The Phase Monitor accessory will monitor the sequence of three-phase electrical systems to provide phase reversal protection. The Phase Monitor will also monitor the phase

voltage inputs (L1, L2, L3) to provide phase loss protection for a three-phase device.

The Phase Monitor will work on either a Delta or Wye power connection.

Phase Reversal Protection

The phase monitor has a bypass function based on line cycles that is factory set for 10 minutes. If the phase monitor determines that all phases are in correct relationship for 10 consecutive minutes and 24 vac is applied, relay K1 will remain energized regardless of the phase sequence of the inputs. (See Fig. 1.)

The bypass function will be reset if all three phases are restored in a phase loss event. The control operation timing is based on 60 Hz system. When the control is used on 50 Hz system, the bypass time may be longer since this timer is based on line cycles.

Phase Loss Protection

If the phase monitor senses that any of the 3 inputs (L1, L2, L3) does not have AC voltage, relay K1 is de-energized. This phase loss protection is always active as long as 24 vac is applied and is not affected by the bypass function. In the event of phase loss, the bypass function is reset. Relay K1 is re-energized only when all three phases are restored and are in correct sequence.

INSTALLATION

Install Phase Monitor

Remove access panel and control box cover.

Attach the Phase Monitor to the high voltage section on the control box using 2 sheet metal screws. (See Fig. 1.)

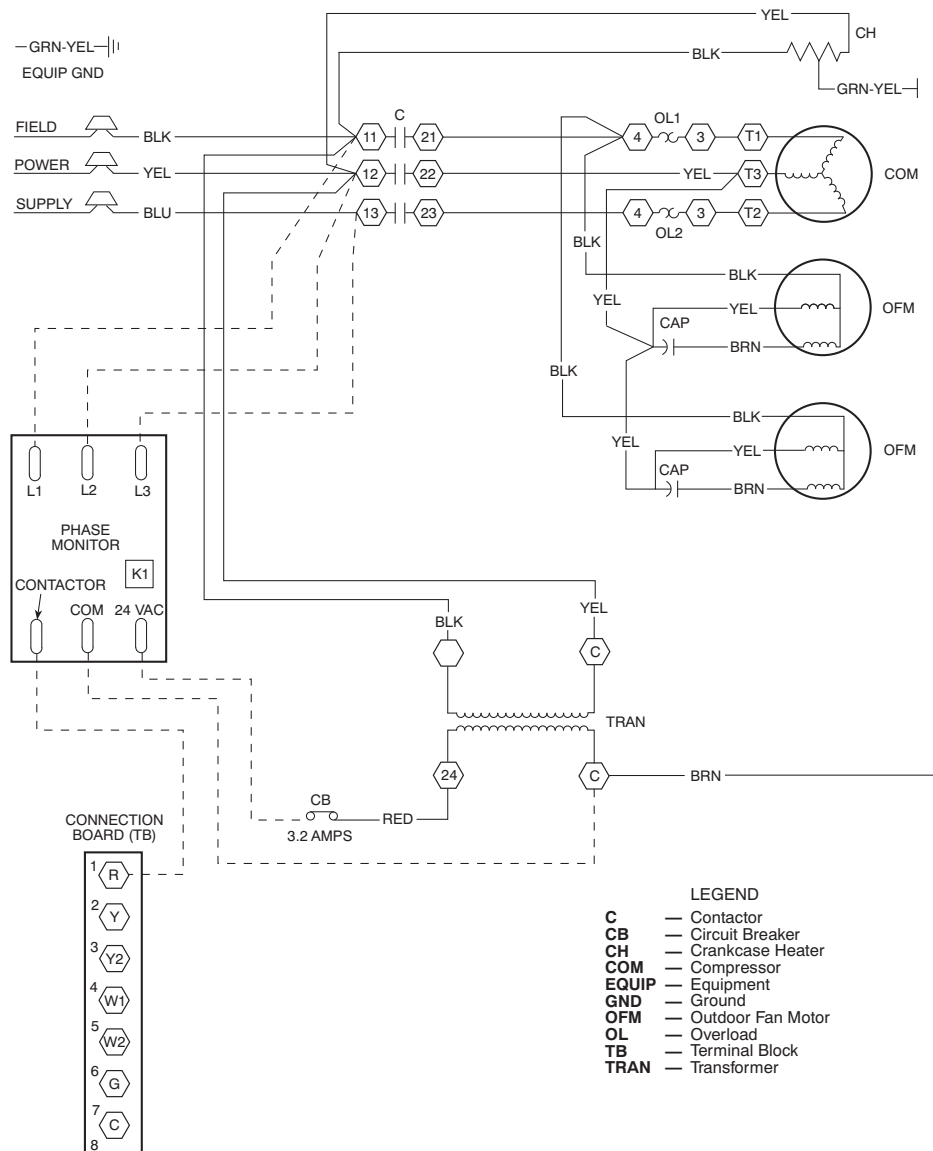

Fig. 1 - Typical Wiring Phase Monitor

C07481

For R-410A Units

1. Disconnect power to unit and install lockout tag and wait 5 minutes. Secure power to the rooftop unit and wait 5 minutes.
2. Install the phase monitor module in the unit control box as shown in Fig. 2. Use the screws provided in the kit, screwing into the pre-drilled holes in the back of the control box.
3. Using the provided wiring harness, connect the female moxex plug to “PMR” male connector on the units mounted terminal board. See the terminal board diagram on Fig. 2.
4. Cut Jumper 1 on control board. (See Fig. 6-9.)
5. a. **For 208/230-460V** - Route the wiring harness along the top of the control box connecting the pink wire to the “CONTACTOR” spade connector, the red wire to the “24VAC” spade, and the brown wire to the “COM” spade of the phase monitor module. (See Fig. 4.)
b. **For 575V** - Route the wiring harness along the top of the control box connecting the pink wire to the “Y-OUT” spade connector, the red wire to the “Y” spade, and the brown wire to the “C” spade of the phase monitor module. (See Fig. 5.)
6. On the phase monitor module, connect the black wire to the “L1” terminal, the yellow wire to the “L3” terminal and the blue wire to the “L2” terminal.
7. **For All Units EXCEPT 48LC and 50LC with 3 Phase Indoor Fan Motor**
On the indoor fan contactor (IFC), connect the black

wire to terminal “11” and the blue wire to terminal “13.” On the compressor contactor (C), (C1) or (C2), connect the yellow wire to terminal “13.” (See Fig. 6.)

For YAC and PHP 208/230-460V and One Phase Indoor Fan Motor EXCEPT 48LC and 50LC

On the compressor contactor (C) or (C1) or on the Indoor Fan Contactor (IFC) on units with crankcase heater, connect the black wire to terminal “11” and the yellow wire to terminal “13.” Connect the blue wire to the input power terminal board (TB). (See Fig. 7.)

For All PAC 208/230-460-575V with One Phase Indoor Fan Motor EXCEPT 48LC and 50LC and YAC and PHP 575V with One Phase Indoor Fan Motor EXCEPT 48LC and 50LC

On the indoor fan contactor (IFC), connect the black wire to terminal “11” and the blue wire to terminal “23.” On the compressor contactor (C) or (C1), connect the yellow wire to terminal “13.” (See Fig. 8.)

For all 48LC and 50LC Units

On the compressor contactor C2 or C connect the black wire to terminal “11”, the yellow wire to terminal “12” and the blue wire to terminal “13”. (See Fig. 9.)

8. Cut the PMR jumper on the terminal board. (See Fig. 2-3.)
9. Restore power to rooftop unit.

CRPHASE

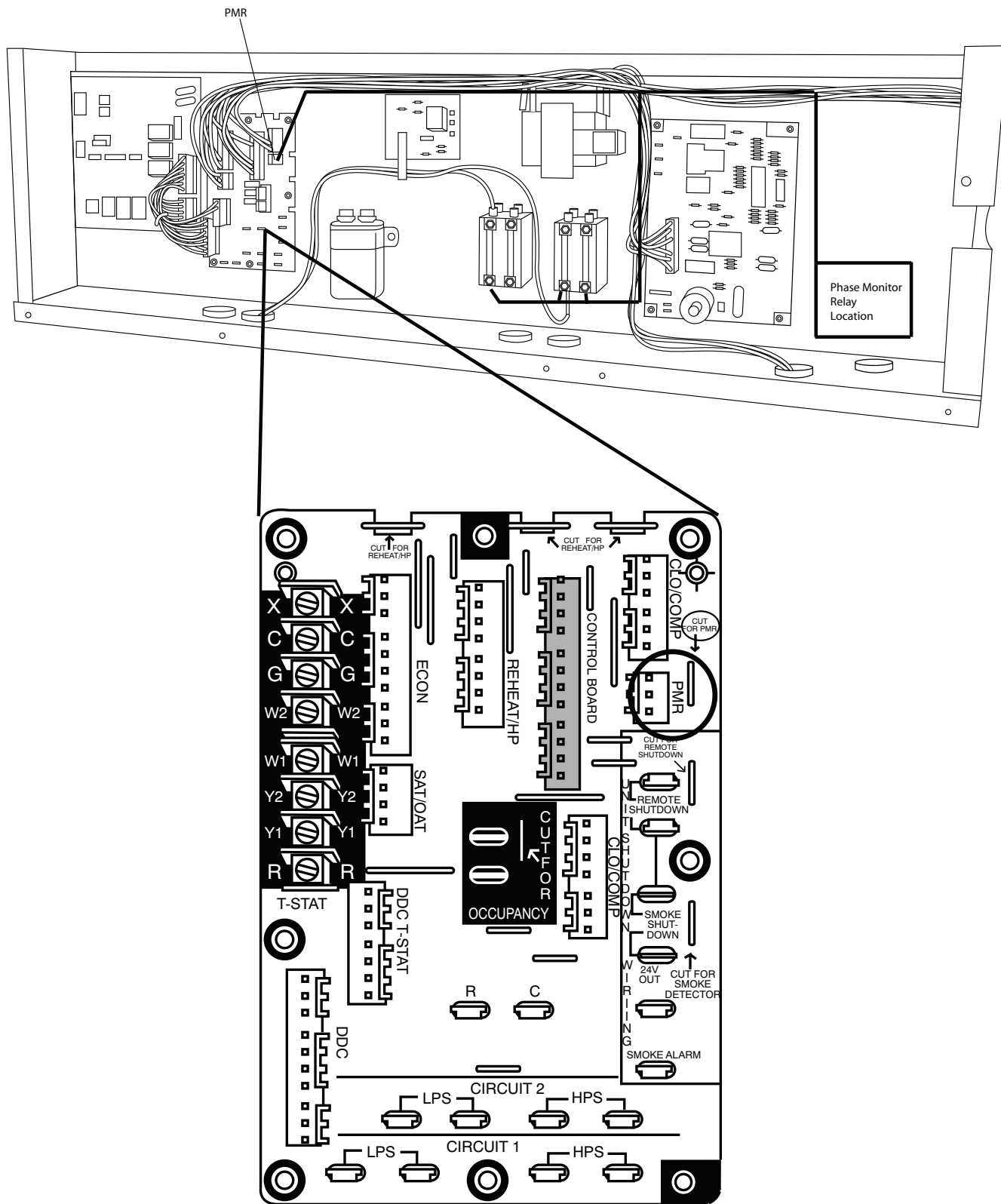

Fig. 2 - Controls Box Showing Mounting Location and Recommended Wire-Routing Path with Exploded View of Terminal Board (YAC with 3-Phase Indoor Fan Motor Shown)

C09490

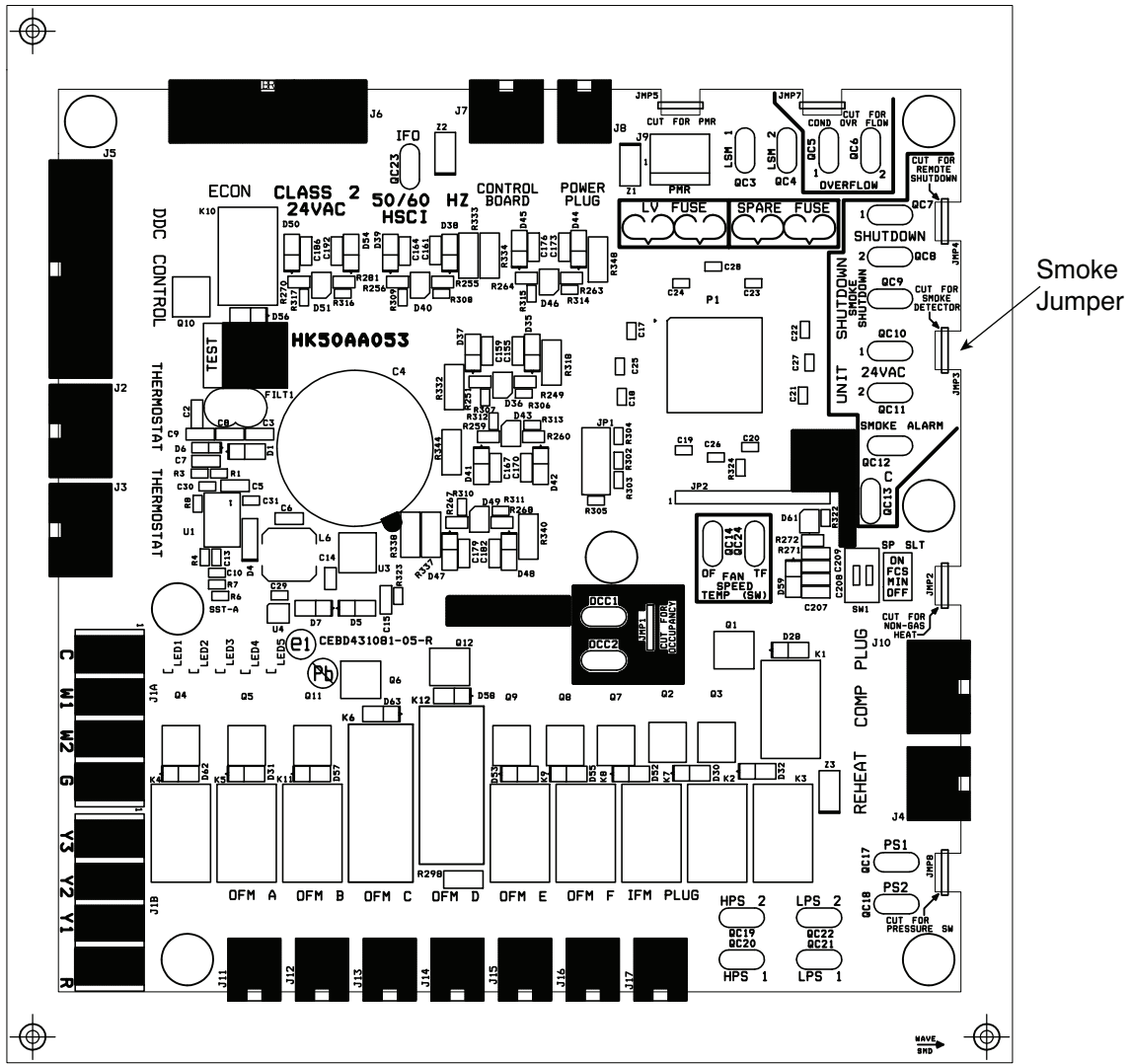

Fig. 3 - 48/50LC Control Board

C13370

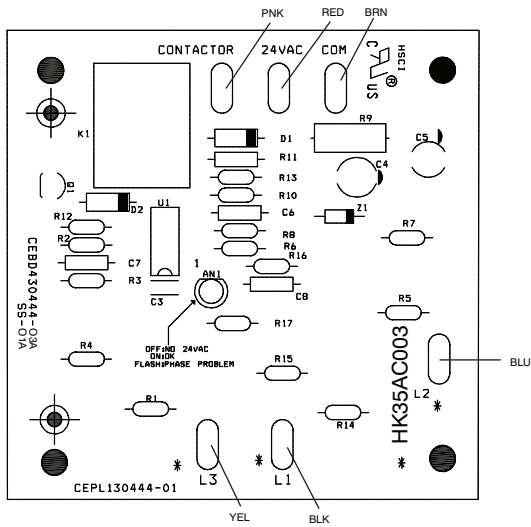

Fig. 4 - Phase Monitor Module Detail (208/230V and 460V)

C08480

CRPHASE

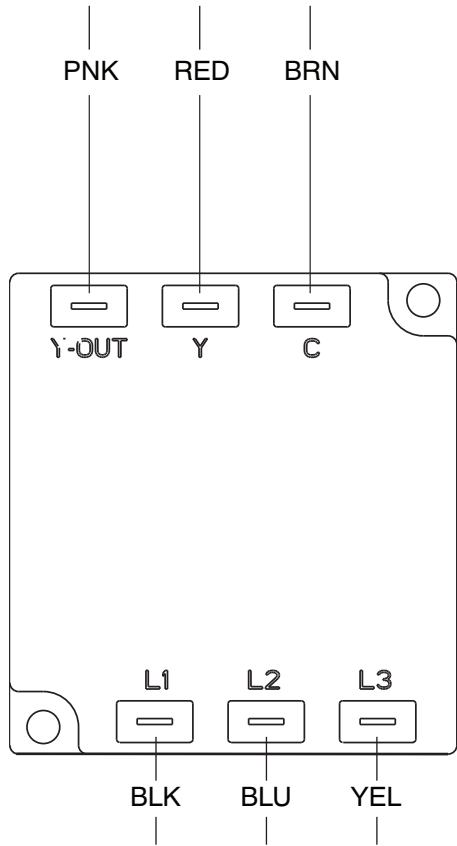

Fig. 5 - Phase Monitor Module Detail (575V)

C08481

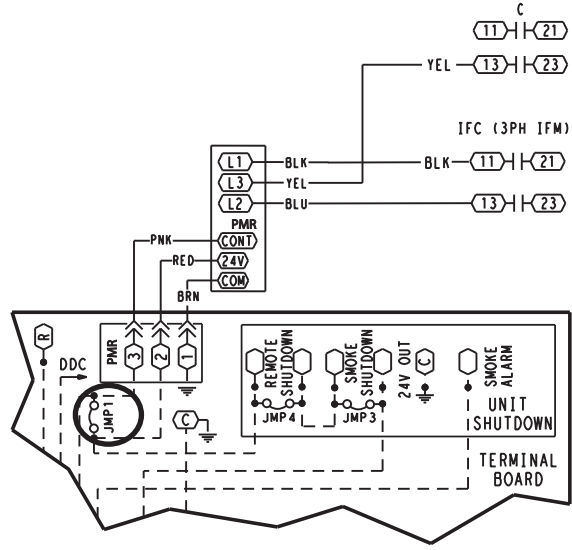

Fig. 6 - Wiring Diagram

C08482

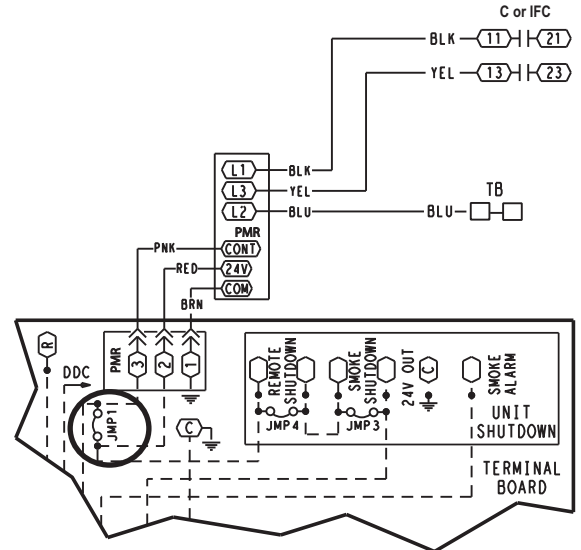

Fig. 7 - Wiring Diagram

C08483

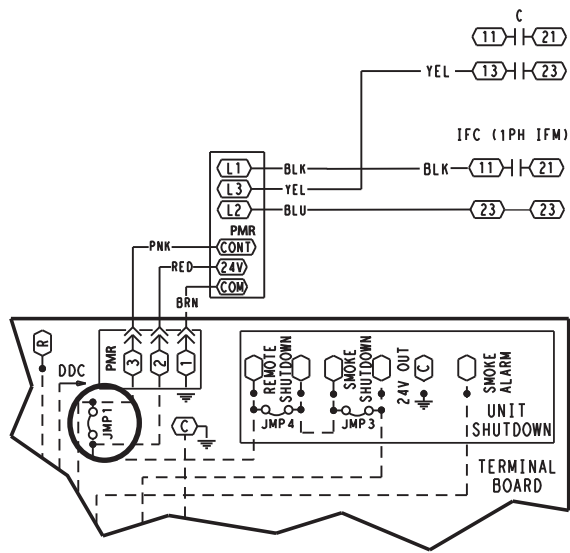

Fig. 8 - Wiring Diagram

C08484

CRPHASE

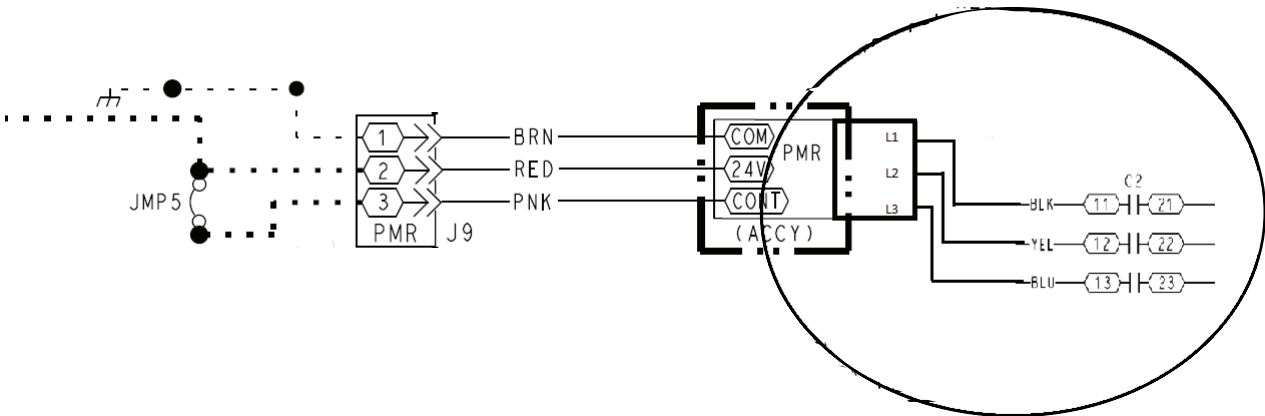

Fig. 9 - 48/50LC Wiring Diagram

C13409

