

VER 150

Energy Recovery Ventilator

PARTS IN THE BOX

Energy Recovery Ventilator, 1 pc
Hanging Chain Kit, 1 pc
Hardware Kit, 1 pc
Drain Hose Kit, 1 pc
Operation and Installation Manual, 1 pc



Your ventilation system should be installed in conformance with the appropriate provincial requirements or, in the absence of such requirements, with the current edition of the National Building Code, and / or ASHRAE's "Good Engineering Practices".

United States

10048 Industrial Blvd., Lenexa, KS, 66215
Tel.: 800.747.1762

Canada

50 Kanalfakt Way, Bouctouche, NB, E4S 3M5
Tel.: 800.565.3548

Fantech reserves the right to modify, at any time and without notice, any or all of its products' features, designs, components and specifications to maintain their technological leadership position.
Please visit our website fantech.net for more detailed technical information.



fantech[®]
a systemair company

				
Note	Warning/ Important note	Information	Technical information	Practical tip



PLEASE READ AND SAVE THESE INSTRUCTIONS

Before installation careful consideration must be given to how this system will operate if connected to any other piece of mechanical equipment, i.e. a forced air furnace or air handler operating at a higher static pressure. After installation, the compatibility of the two pieces of equipment must be confirmed by measuring the airflow of the Energy Recovery Ventilator using the balancing procedure found in this manual. It is always important to assess how the operation of any ERV may interact with vented combustion equipment (i.e. Gas Furnaces, Oil Furnaces, Wood Stoves, etc.)



Products are designed and manufactured to provide reliable performance, but they are not guaranteed to be 100% free of defects. Even reliable products will experience occasional failures, and this possibility should be recognized by the user. If these products are used in a life support ventilation system where failure could result in loss or injury, the user should provide adequate back-up ventilation, supplementary natural ventilation or failure alarm system, or acknowledge willingness to accept the risk of such loss or injury.

Your ventilation system should be installed in accordance with the local building code that is in effect, in absence of such requirements, it is recommended to check with local authorities having jurisdiction in your area prior to installing this product.

TABLE OF CONTENTS

DETERMINING YOUR AIRFLOW REQUIREMENT	4
INSTALLATION EXAMPLES	
Fully dedicated system	5
Partially dedicated system	6
Simplified Installation	
Option 1	7
Option 2	8
EXTERIOR DUCTING INSTALLATION	
Weatherhood Location	9
Installing the ducting to the weatherhood	9
INTERIOR DUCTING INSTALLATION	
General Tips	10
Installing duct to ERV	10
Supply & Exhaust Air Grilles Location	10
ERV INSTALLATION	11
AIRFLOW ADJUSTMENT & BALANCING	
General preparation	13
Adjusting airflow using integrated balancing system	13
Balancing steps	14
LOW VOLTAGE CONTROL SYSTEMS	15
WIRING DIAGRAM	17
TROUBLESHOOTING	19
ERV CORE WASHING INSTRUCTIONS	20
PARTS LIST	21

DETERMINING YOUR AIRFLOW REQUIREMENT

Room Count Method

Room classification	Number of rooms	CFM (L/s)	CFM Required
Master bedroom		x 10 L/s (20 CFM)	=
Basement	yes or no	if yes add 10 L/s (20 CFM) if no = 0	=
Bedrooms		x 5 L/s (10 CFM)	=
Living room		x 5 L/s (10 CFM)	=
Others		x 5 L/s (10 CFM)	=
Kitchen		x 5 L/s (10 CFM)	=
Bathroom		x 5 L/s (10 CFM)	=
Laundry room		x 5 L/s (10 CFM)	=
Utility room		x 5 L/s (10 CFM)	=
Total Ventilation Requirements (add last column)			=

1 CFM = 0.47 L/s

1 L/s = 2.13 CFM

ASHRAE method

Ventilation Air requirements

Floor area		Bedrooms									
Ft ²	m ²	1		2		3		4		5	
		CFM	L/s	CFM	L/s	CFM	L/s	CFM	L/s	CFM	L/s
<500	<47	30	128	38	18	45	21	53	25	60	28
205-1000	47-93	45	21	53	24	60	28	68	31	75	35
1001-1500	94-139	60	28	68	31	75	35	83	38	90	42
1501-2000	140-186	75	35	83	38	90	42	98	45	105	49
2001-2500	187-232	90	42	98	45	105	49	113	52	120	56
2501-3000	233-279	105	49	113	52	120	56	128	59	135	63
3001-3500	280-325	120	56	128	59	135	63	143	66	150	70
3501-4000	326-372	135	63	143	66	150	70	158	73	165	77
4001-4500	373-418	150	70	158	73	165	77	173	80	180	84
4501-5000	419-465	165	77	173	80	180	84	188	87	195	91

* ASHRAE 62.2-2016 Table 4.1, Ventilation and Acceptable Indoor Air Quality in Low-Rise Residential Buildings.



Bathroom: If the HRV is going to provide the required local exhaust ventilation for each bathroom with each a continuous 20 CFM (10 L/s), this ventilation rate can be considered as part of the whole-building ventilation rate.

INSTALLATION EXAMPLES

Example only – duct configuration may differ depending on the model.

FULLY DEDICATED SYSTEM BEST FOR NEW CONSTRUCTION



1. Stale air is drawn from key areas of the home requiring local exhaust (bathroom, kitchen, laundry room).
2. Fresh air is distributed directly to habitable rooms in the house (bedrooms, living room)
3. The ERV's airflow must be balanced after installation using the procedure found in the section "AIRFLOW BALANCING"

Suggested installation for:

- Hydronic baseboard
- Infloor heating
- Electric baseboard
- Mini split heat pump

Benefits: Provides the best fresh air distribution in the house; lowest operation cost since the furnace/air handler unit is not needed.

ERV ducting for fully Dedicated System

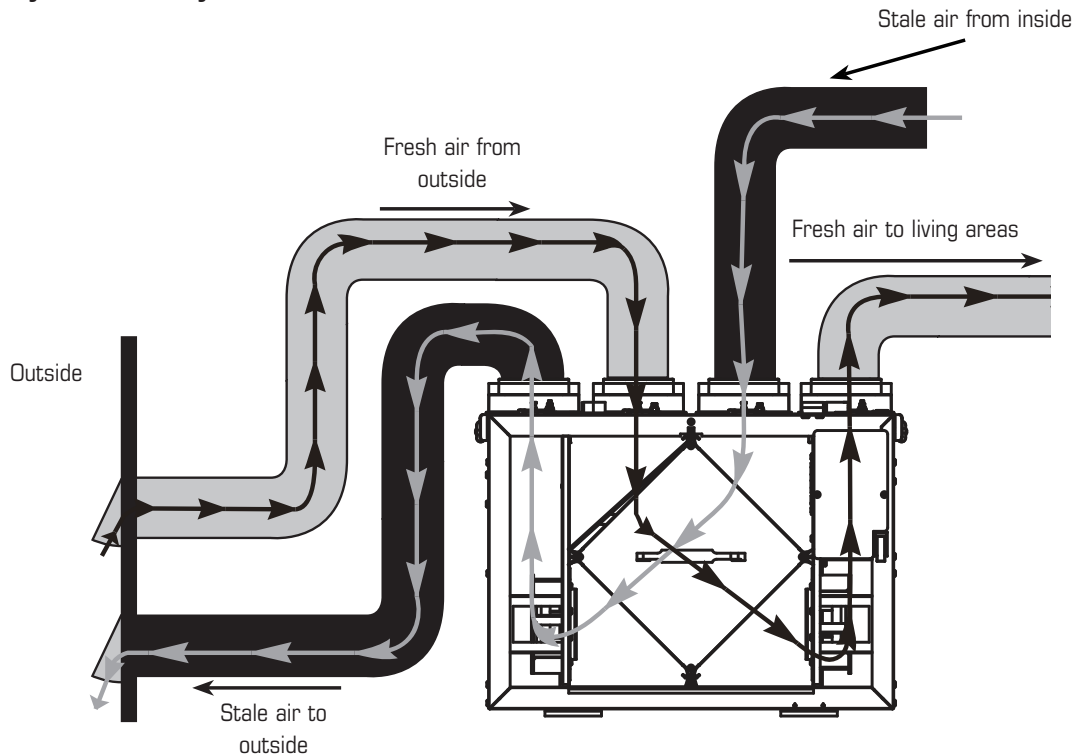

INSTALLATION EXAMPLES (CONT'D)

DIRECT CONNECTION of the FRESH air to living area to the RETURN PLENUM of the AIR HANDLER (Stale air drawn from key areas of home)

PARTIALLY DEDICATED SYSTEM (BETTER)



1. In order to provide proper distribution of the fresh air, it is recommended that the furnace blower be set to run continuously or interconnected with ERV. See furnace electrical connection on page 18.
2. Stale air is drawn from key areas of the home (bathroom, kitchen, laundry room).
3. Fresh air is supplied to the return air plenum of the furnace.
4. Due to the difference in pressure between the ERV and the equipment it is being connected to the ERV's airflow must be balanced on site, using the procedure found in the section "AIRFLOW BALANCING"

* In the case of a multi-zone system, please contact Fantech customer service prior to installing any installation type requiring the use of the furnace interlock"

Suggested installation for:

- Central furnace (air handling unit or central air conditioners)
- When ducting fresh air to living area is not possible or practical, i.e. expensive or when the central AHU will operate year-round.

Benefits: Conditions the fresh air prior to distributing it throughout the house

ERV/ Furnace ducting for Partially Dedicated System

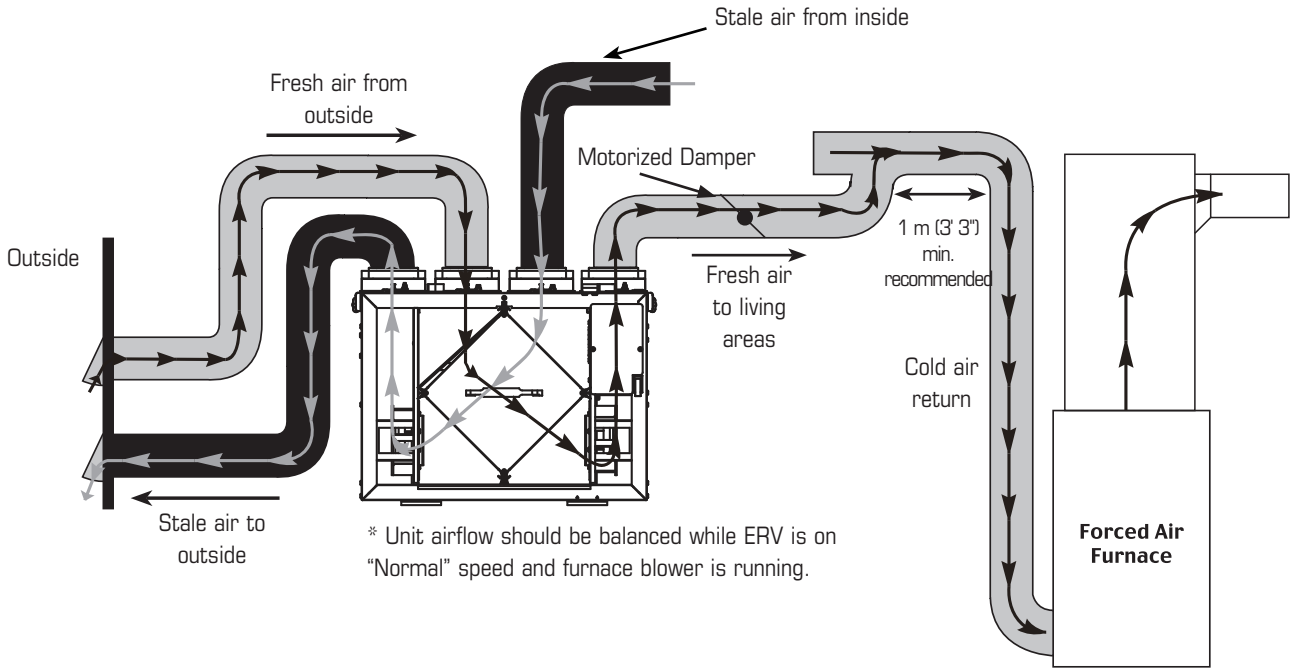

Fantech energy recovery ventilators (ERV) that use a supply fan shutdown for frost prevention do not include an outdoor air motorized damper. If you are using a simplified installation, i.e. connecting the ERV supply air duct to a furnace's return air duct, the ERV must operate continuously. When the ERV is turned off, no warm exhaust air will flow through the ERV but the furnace's fan will continue to draw in outdoor air directly into the furnace. If it's cold outside, cold air will be introduced, without re-heating, directly into the furnace.

If the ERV is installed such that the homeowner may turn off the ERV during the winter, we recommend installing a motorized damper between the ERV's supply air and the furnace's return air duct that closes when the ERV is not operating. See wiring diagram (figure 1).

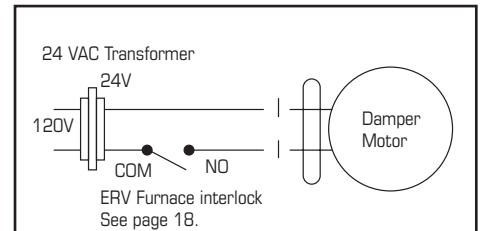

Figure 1

*Transformer and Damper motor not included

INSTALLATION EXAMPLES (CONT'D)

DIRECT CONNECTION of both the ERV SUPPLY AIR STREAM and EXHAUST AIR STREAM to the FURNACE COLD AIR RETURN

SIMPLIFIED INSTALLATION (GOOD) (RETURN/RETURN METHOD) - OPTION 1



1. Furnace blower must operate when ventilation from ERV is required. The furnace should be set to run continuously or interlocked with ERV. See furnace electrical connection on page 18.
2. A minimum separation of 1m (39") is recommended between the two direct connections.
3. In order to prevent exhausting any fresh air, the ERV's exhaust air connection should be upstream of the ERV's supply air connection when ducting to the furnace's cold air return.
4. Due to the difference in pressure between the ERV and the equipment it is being connected to the ERV's airflow must be balanced on site, using the procedure found in the section "AIRFLOW BALANCING"

* In the case of a multi-zone system, please contact Fantech customer service prior to installing any installation type requiring the use of the furnace interlock"

Suggested installation for:

- When bathroom and kitchen already have local exhaust system
- May be suitable for retrofitting

Benefits: Least expensive installation type

ERV/ furnace for Simplified Installation – Option 1

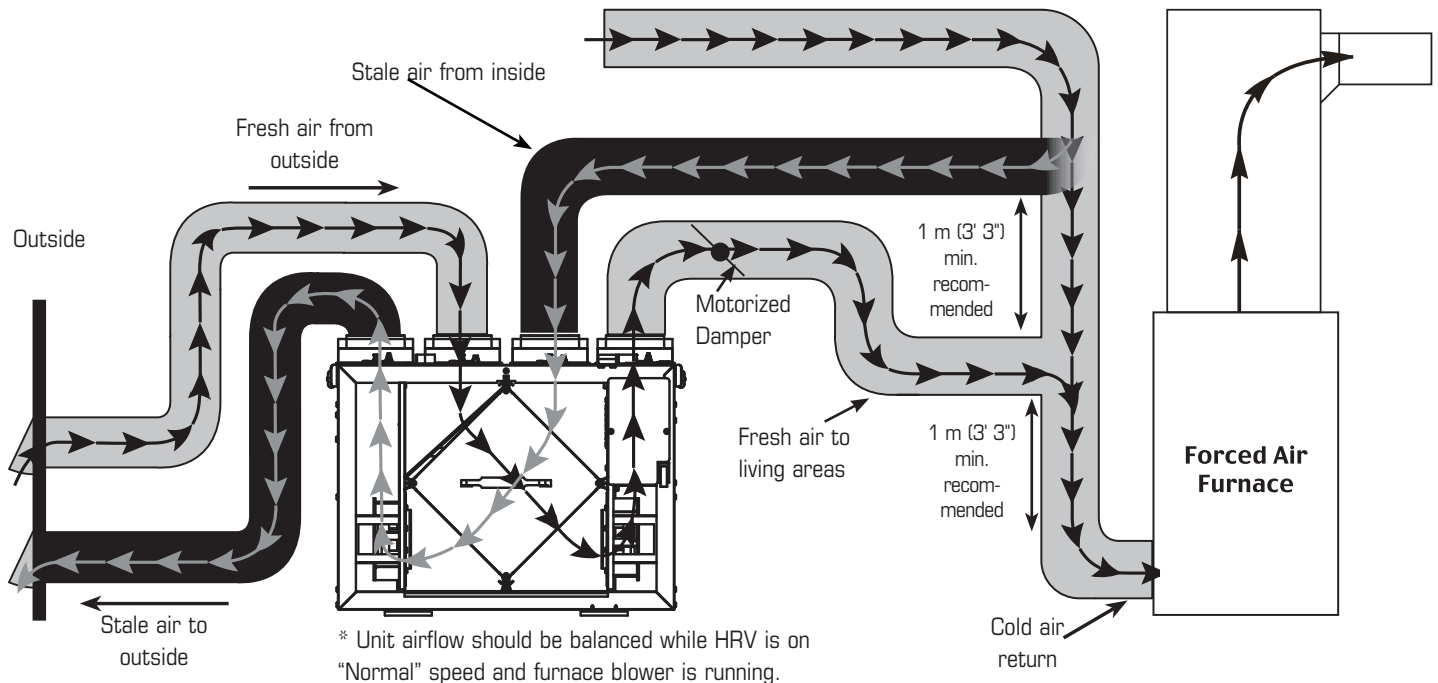

Fantech energy recovery ventilators (ERV) that use a supply fan shutdown for frost prevention do not include an outdoor air motorized damper. If you are using a simplified installation, i.e. connecting the ERV supply air duct to a furnace's return air duct, the ERV must operate continuously. When the ERV is turned off, no warm exhaust air will flow through the ERV but the furnace's fan will continue to draw in outdoor air directly into the furnace. If it's cold outside, cold air will be introduced, without re-heating, directly into the furnace.

If the ERV is installed such that the homeowner may turn off the ERV during the winter, we recommend installing a motorized damper between the ERV's supply air and the furnace's return air duct that closes when the ERV is not operating. See wiring diagram (figure 1).

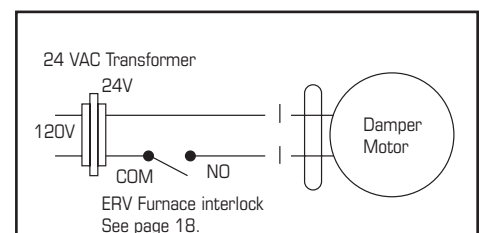

Figure 1

*Transformer and Damper motor not included

Installation examples (Cont'd)

DIRECT CONNECTION of the ERV SUPPLY AIR STREAM to the SUPPLY AIR SIDE on the FURNACE & EXHAUST AIR STREAM to the FURNACE COLD AIR RETURN

SIMPLIFIED INSTALLATION (GOOD) OPTION 2



1. Furnace blower must operate when ventilation from ERV is required. The furnace should be set to run continuously or interlocked with ERV. See furnace electrical connection on page 18.
2. Due to the differences in pressure between the ERV and the equipment it is being connected to, the ERV's airflow must be balanced on site, using the procedure found section "AIRFLOW BALANCING".

* In the case of a multi-zone system, please contact Fantech customer service prior to installing any installation type requiring the use of the furnace interlock"

Suggested installation for:

- When bathroom and kitchen already have local exhaust system
- May be suitable for retrofitting

Benefits: Least expensive installation type



In the case of a simplified installation, Option 1 is recommended.

ERV/Furnace ducting for Simplified Installation - Option 2

* Ductwork layout may differ depending on model

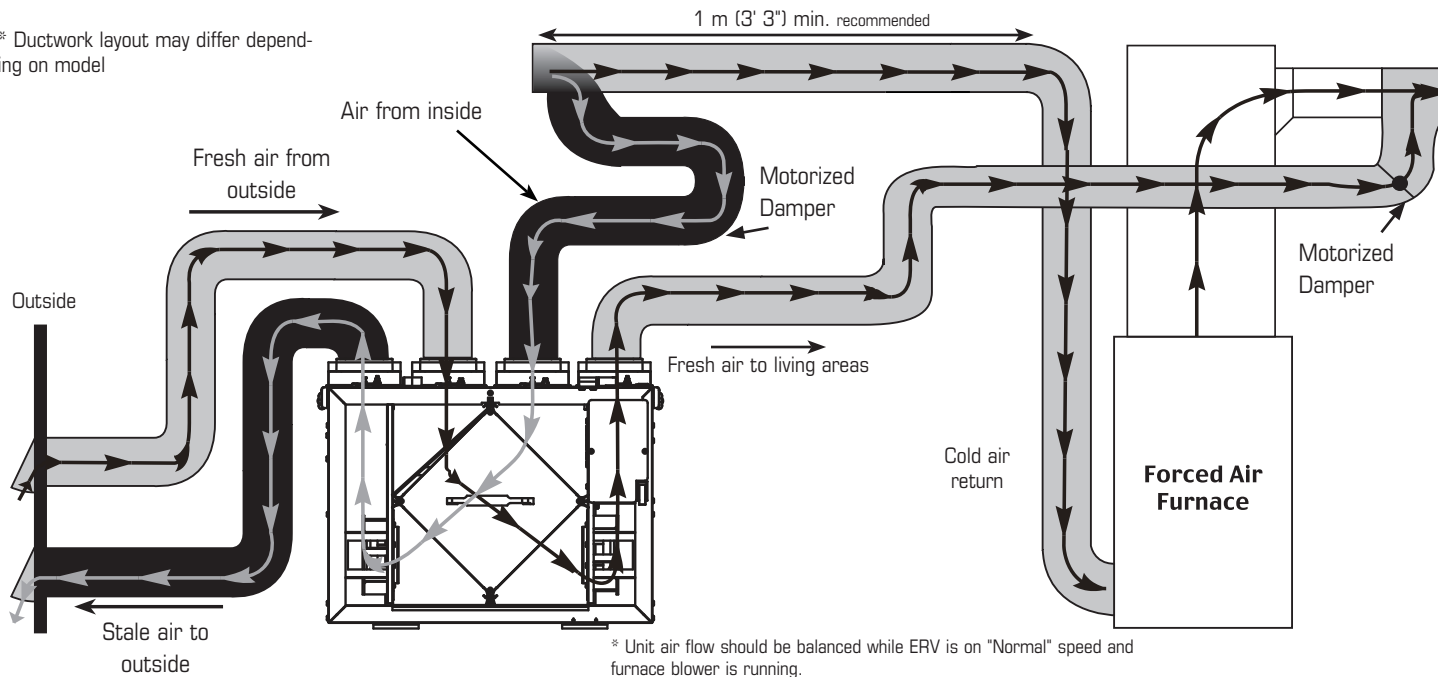

* Unit air flow should be balanced while ERV is on "Normal" speed and furnace blower is running.



Fantech energy recovery ventilators (ERV) that use a supply fan shutdown for frost prevention do not include an outdoor air motorized damper. If you are using a simplified installation, i.e. connecting the ERV supply air duct to a furnace's return air duct, the ERV must operate continuously. When the ERV is turned off, no warm exhaust air will flow through the ERV but the furnace's fan will continue to draw in outdoor air directly into the furnace. If it's cold outside, cold air will be introduced, without re-heating, directly into the furnace.

If the ERV is installed such that the homeowner may turn off the ERV during the winter, we recommend installing a motorized damper between the ERV's supply air and the furnace's return air duct that closes when the ERV is not operating. See wiring diagram (figure 1).

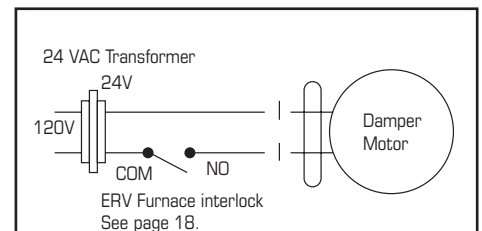

Figure 1

*Transformer and Damper motor not included

EXTERIOR DUCTING INSTALLATION

WEATHERHOOD LOCATION

- Decide where your intake and exhaust hoods will be located.

Locating the Intake Weatherhood

- Should be located upstream (if there are prevailing winds) from the exhaust outlet.
- At a minimum distance to 900 mm (3') away from dryer vents and furnace exhaust (medium or high efficiency furnaces), driveways, oil fill pipes, gas meters, or garbage containers.
- At a minimum height of 460mm (18") above the ground, or above the level of expected snow accumulation.
- Ideally, keep weatherhoods 1m (3') from corners.
- Do not locate in the garage, attic, crawl space, or underneath deck.

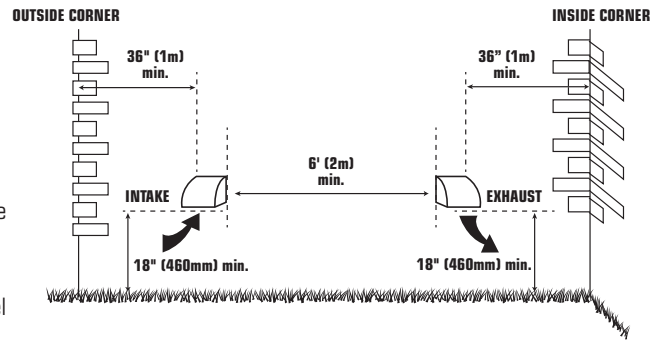

Locating the Exhaust Weatherhood

- At least 460mm (18") above ground or above the depth of expected snow accumulation
- Ideally, keep weatherhoods 1m (3') from corners.
- Not near a gas meter, electric meter or a walkway where fog or ice could create a hazard
- Do not locate in a garage, workshop or other unheated space

INSTALLING THE DUCTING TO THE WEATHERHOODS

A well designed and installed ducting system will allow the ERV to operate at its maximum efficiency. The inner liner of the flexible insulated duct must be secured to the sleeve of the weatherhood (as close to the outside as possible) and to the appropriate duct connection on the ERV. The insulation should remain full and not crushed. The outer liner, which acts as a vapor barrier, must be completely sealed to the outer wall and the ERV using tape and/or caulking. A good bead of high quality caulking (preferably acoustical sealant) will seal the inner flexible duct to both the ERV duct connection and the weatherhood prior to securing them.

To minimize airflow restriction, the flexible insulated duct that connects the two outside weatherhoods to the ERV should be stretched tightly and be as short as possible.

Twisting or folding the duct will severely restrict airflow.

See "Installation Diagram Examples" for installation examples.

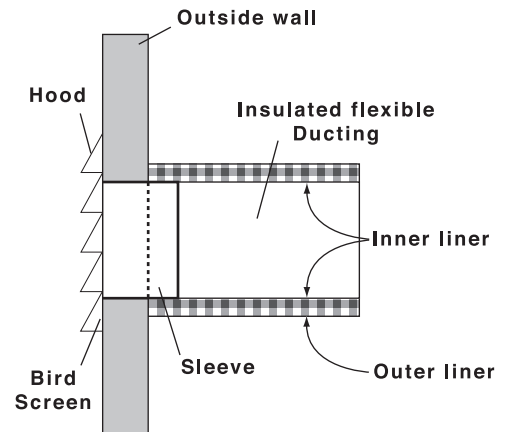

STEPS FOR HOOD INSTALLATION:

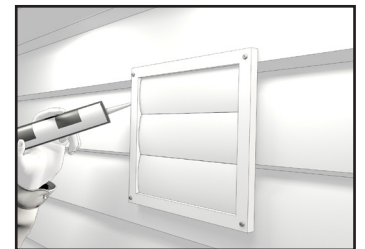
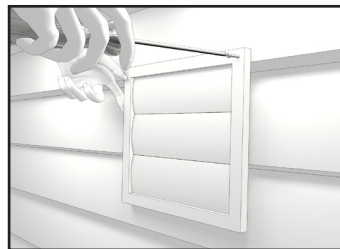
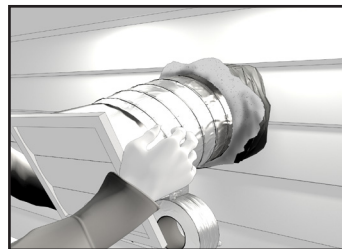
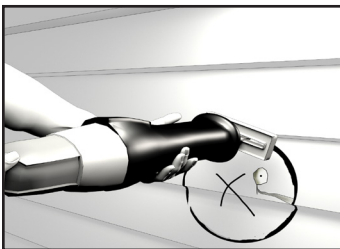

1 Using the duct connection of the outside hood, outline the intake & exhaust holes to be cut. The holes should be slightly larger than the duct connection to allow for the thickness of the insulated flexible duct. Cut a hole for both the intake and exhaust hoods.

2 Pull the insulated flexible duct through the opening until it is well extended and straight. Slide the duct's inner vinyl sleeve over the hood duct connection and secure. Pull the insulation over the duct and pull the vapor barrier over the sleeve. Secure with appropriate tape or sealant.

3 Push the hood into the opening and then attach the hood to the outside wall with mounting screws. Repeat the installation procedure for both the supply and exhaust hoods.

4 Using a caulking gun, seal around both hoods to prevent any leaks.

INTERIOR DUCTING INSTALLATION



- To maximize airflow through the ductwork system, all ducts should be kept short and have as few bends or elbows as possible.
- 45° elbows are preferable to 90°.
- Use “Y” ducts instead of “T” ducts whenever possible.
- All duct joints must be fastened with screws or duct sealant and wrapped with aluminum foil duct tape to prevent leakage.
- Galvanized ducting from the ERV to the living areas in the house is recommended whenever possible, although flexible ducting can be used in moderation when necessary.
- To avoid possible noise transfer through the ductwork system, a short length (approximately 300mm, 12”) of nonmetallic flexible insulated duct should be connected between the ERV and the supply/exhaust ductwork system.
- The main supply and return line to/from the ERV must have the same diameter as the duct connection or larger.
- Branch lines to the individual rooms may be as small as 100mm (4”).

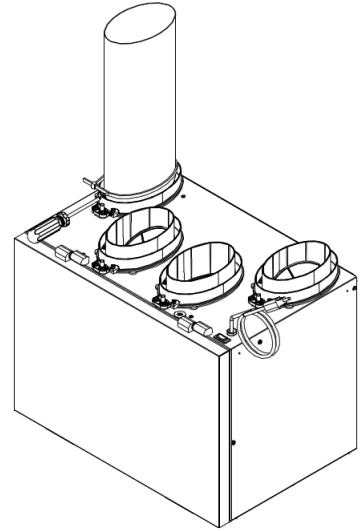

INSTALLING DUCT TO ERV

For flexible duct installation, slide flexible ducting onto duct connection. Then install a cable tie over flexible duct to prevent leakage between the ducting and the duct connection.

In the case of solid ducting, slide duct over duct connection, screw in place and seal.

SUPPLY AIR GRILLES LOCATION

In homes without a forced air furnace, fresh air should be supplied to all habitable rooms, including bedrooms and living areas. It should be supplied from high wall or ceiling locations. Grilles that diffuse the air comfortably are recommended. In homes with a forced air furnace, you may want to connect the ERV to the furnace ductwork (see information below).

EXHAUST AIR GRILLES LOCATION

The stale air exhaust system is used to draw air from the points in the house where the worst air quality problems occur. It is recommended that return air ducts be installed in the bathroom, kitchen, and laundry room. Additional return air ducts from strategic locations may be installed. The furnace return duct may also be used to exhaust from. In this method, the exhaust air is not ducted back from bathrooms, kitchens, etc to the ERV with “dedicated lines”.



As per building codes and installation requirements for combustion appliances:

Air return ducts, or openings for air return, should not be placed in enclosed spaces containing combustion appliances that are subject to spillage.

ERV INSTALLATION



- Have a nearby power supply (120 volts, 60Hz)
- Choose a location which allows the possibility of mounting the unit to supporting beams.
- The unit should be level in order to allow proper condensate drainage
- To minimize noise, do not install unit in living area
- Ensure proper drainage

LOCATION

The ERV must be located in a conditioned space where it will be possible to conveniently service the unit. Typically the ERV would be located in the mechanical room or an area close to the outside wall where the weatherhoods will be mounted. If a basement area is not convenient or does not exist, a utility room may be used.

Attic installation must meet the following conditions:

- Attic temperature must be above freezing conditions at all times and for best performance should be 12°C (54 °F).
- The condensate drain (if included) must be installed so that the condensate drains and is protected from freezing.
- The attic is easily accessible for equipment maintenance and inspection.

Connecting appliances to the ERV is not recommended. These include:

- Clothes dryer
- Range top
- Stovetop fan
- Central vacuum system
- Bathroom exhaust fans unless they are specifically designed for this purpose

These appliances may cause lint, dust or grease to collect in the ERV, damaging the unit.



Connecting any of these types of appliances to the ERV will void your warranty.

Mounting- Chain mount

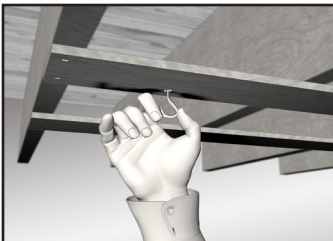

- 1 Place fastening hooks on the strapping board or the floor joists.

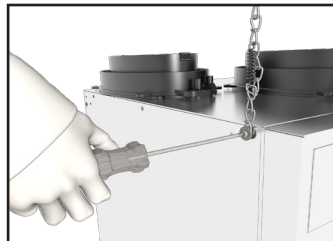

- 2 Attach a hanging chain (provided) to each 19 mm (3/4") bolt (provided) in the top 4 corners of the unit and tighten.



- 3 Hang the unit by slipping a link onto the hanging hooks, making sure the unit is level.



- 4 Install a spring on each chain. Hook the spring in the links so a loop is created in the chain. The spring will then support the unit's weight and absorb vibrations.

INSTALLING DRAIN LINE

Through normal operation and during its defrost mode, the ERV may produce some condensation. This water should flow into a nearby drain, or be taken away by a condensate pump. The ERV and all condensate lines must be installed in a space where the temperature is maintained above the freezing point. A "P" trap should be made in the drain line. This will prevent odors from being drawn back up into the unit.



The drain nipple is placed upside down in the unit to prevent it being damaged during shipping or the installation of the unit. For both drain and drainless installation the drain nipple needs to be flipped.

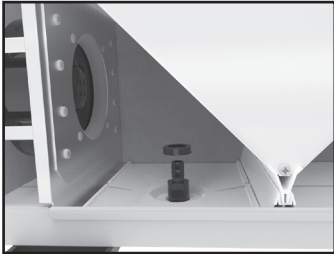

1 Remove the nutsert.

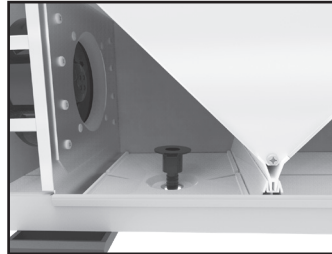

2 Invert the drain nipple. Make sure to place gasket between the unit and the drain nipple inside the unit.

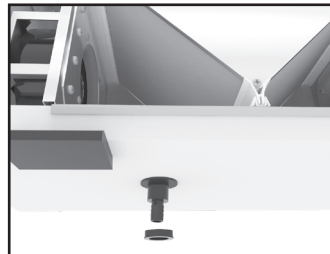

3 Secure the drain nipple using the nutsert.

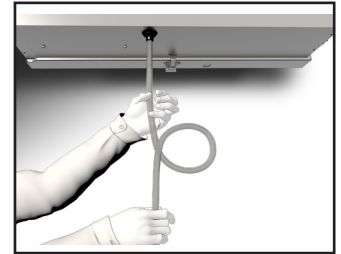

4 Install the drain hose making a "P" trap, secure the condensate line drain connection using the tube clamp provided. Fill the condensate line with water.



Caution:

A Drain and Tubing (included) must be installed for all HRV units. For ERV units, drain is not required, however, it is recommended for climates where outdoor temperature typically remains below -25°C (-13°F) combined with an indoor relative humidity higher than 40% for a period of 24 hours or several days in a row.

AIRFLOW ADJUSTMENT & BALANCING



BALANCING THE AIRFLOWS IS CRUCIAL TO ENSURE OPTIMAL OPERATION OF THE UNIT. IF THE AIRFLOW IS NOT PROPERLY BALANCED, THE FOLLOWING ISSUES MAY OCCUR:

- SIGNIFICANT POSITIVE OR NEGATIVE PRESSURE INSIDE THE HOUSE
- UNIT'S EFFICIENCY MAY BE NEGATIVELY AFFECTED
- UNIT'S DEFROST MAY NOT WORK EFFECTIVELY
- CAN LEAD TO AIR LEAKS OR BACKDRAFTING OF ANY COMBUSTION APPLIANCES.

The airflow adjustment and balancing procedure consists of adjusting the fresh airflow to make sure it meets the requirements for the building and then balance the system to make sure there is an equal amount of stale air being exhausted. In the case that the airflow is not exactly the same, it is recommended to have a higher stale airflow of up to 10% in colder climates to ensure that the temperature of the fresh airflow coming from the outside is as close to the room temperature as possible.

GENERAL PREPARATION:

Before performing the adjustment and balancing for unit, make sure to check the following:

- Seal all the ductwork
- Fully open all dampers (if present)
- Turn off all other exhaust appliances such as range hood, dryers, bathroom fans, etc.
- If performing balancing during cold weather, make sure the unit is not operating in defrost mode.
- If the installation type is Simplified or Partially Dedicated, make sure that the furnace/air handler blower is operating at normal speed during the balancing sequence.
- When reading with a mechanical type manometer (Magnehelic), make sure the manometer is placed on a level surface

For optimal performance, ERV unit should be re-balanced after a major renovation or after the installation of extra grilles or registers.



- In cold climates, continuous excessive positive pressure inside the house may drive moisture inside the external walls of the house. Moisture present inside the external wall may condense if the outside temperature is cold enough and can cause damage to structural components. A symptom of excessive positive pressure inside a house is frozen door locks.
- Continuous excessive negative pressure can have undesirable effects. In some geographic locations, negative pressure can increase the infiltration of soil gases such as methane and radon. Negative pressure is also undesirable where combustion equipment is present and may cause back drafting of the combustion gases.

ADJUSTING AIRFLOWS USING INTEGRATED BALANCING SYSTEM

Adjustable dampers are integrated into the Fresh Air to Building and the Stale Air to Outside duct connections. Those dampers replace the installation of separate back draft and balancing dampers in the duct line.

The integrated dampers are preset at the fully opened position. In order to reduce the amount of airflow, turn the adjustable lever using a flat screw driver by turning it counter clock wise. Turning the lever clockwise may damage the plastic screw head. Follow the balancing steps to properly adjust the airflow.

BALANCING STEPS



Use balancing chart located on the door of the ERV

STEP #1: Identify the desired airflow using the provided chart. From the desired airflow (left column) identify the pressure reading needed by simply following the line. Make sure to set the unit at the Normal speed before performing the next step.

STEP #2: Measure the pressure reading by connecting a manometer on the LOW and HIGH pressure ports located on the duct connection. Refer to **Illustration #1**. If the pressure reading is LOWER than the desired value, adjust the balancing dampers by turning the adjustable arm counter clockwise until the correct corresponding pressure value is reached. Refer to **Illustration #2**. Do the same for both the SUPPLY and EXHAUST airflows. If the pressure reading is HIGHER than desired when the damper is fully opened, please check the distribution system for any anomalies that could increase the resistance in the distribution system.

BALANCING CHART (example only)

Airflow		Normal Speed		Reduced Speed	
CFM	L/s	Δ In W.G. Pressure reading	Δ Pa	Δ In W.G. Pressure reading	Δ Pa
110	52	0.36	91		
100	47	0.46	114		
90	42	0.55	137		
80	38	0.64	161		
70	33	0.74	184	0.13	32
65	31	0.78	195	0.16	40
60	28	0.83	207	0.19	48
55	26	0.87	219	0.22	55
50	24	0.92	230	0.25	63

EXAMPLE



- If the house is tightly sealed, adjusting one airflow may affect the other airflow as well. It is recommended to check each airflow again to make sure the value did not change dramatically during the balancing procedure. Make adjustments as necessary.
- The pressure reading from the duct connection refers to the total pressure loss from the distribution system. A well designed distribution system should have a total pressure loss between 0.4" (100Pa) and 0.6" (150Pa). The pressure reading can therefore be used to troubleshoot distribution system. If the pressure reading is higher than 0.6" (150Pa), we recommend that you inspect the system and check for closed grilles, blocked exterior hoods or twisted flexible duct.

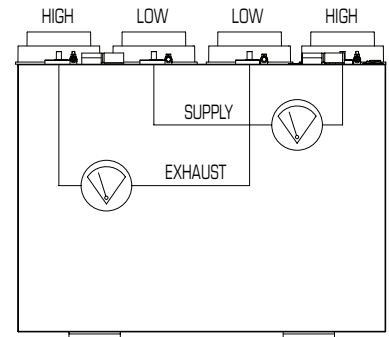

Illustration #1

STEP #3: Secure the adjustable arm by tightening the set screw as shown in **Illustration #3**.

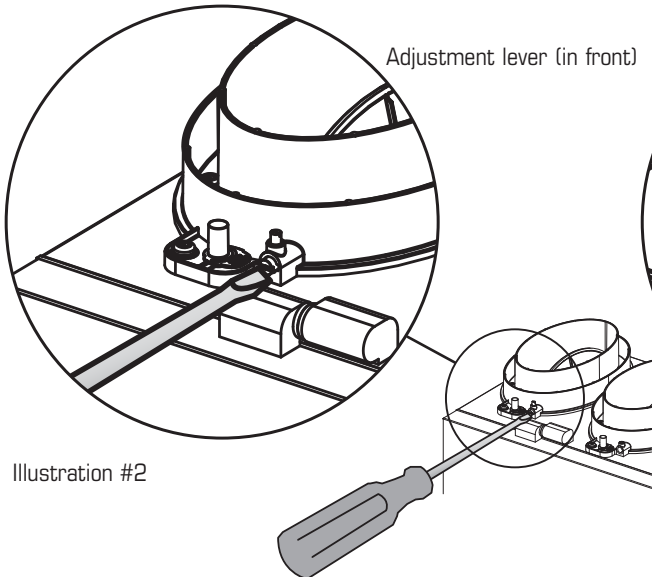

Illustration #2

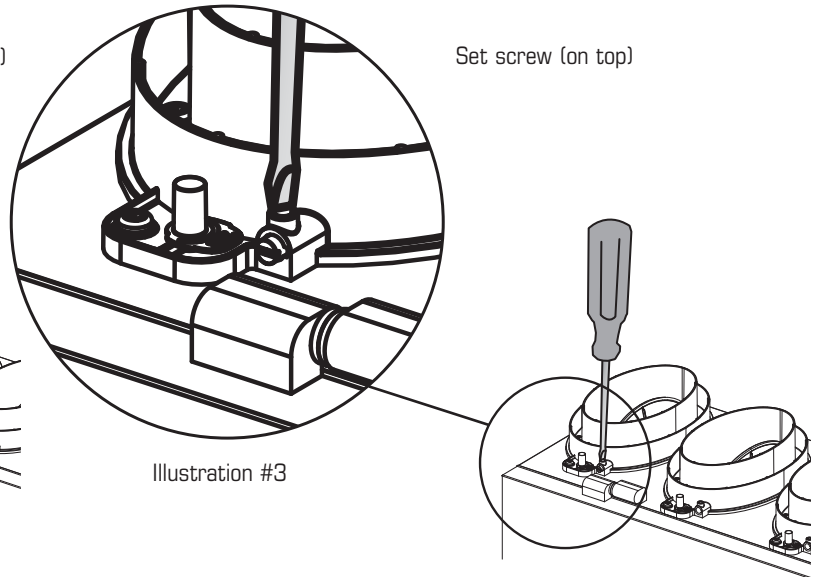

Illustration #3

WALL CONTROLS

* Please see instruction manuals for individual controls for proper wiring and set up of control systems.



1. Ensure that unit is not plugged when connecting the control
2. Recirculation mode is only available with the Flex100H ES, HERO series and the models with the "R" suffix at the end of the model number.







The wiring connectors can be removed for easier connection.

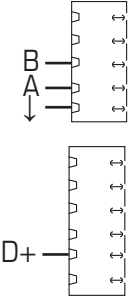

CENTRAL CONTROLS

These cannot be used with another central control

*Maintain polarity between control and HRV (+ → + ; - → -)



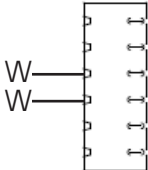

ECO SERIES*	FEATURES	CONNECT TO
<p>ECO-Touch®</p> 	<ul style="list-style-type: none"> • Our most complete, yet easy-to-use control system • Sleek design with backlight touchscreen LCD • ECO mode selects the best operating mode and speed for the season, minimizing energy use associated with ventilation • Set preferred indoor relative humidity range and ventilation mode for day and night conditions • No battery to replace, all programmed settings are retained during power outages • Maintenance reminder indicator • Error code messages reduce troubleshooting time 	
<p>ECO-Touch^{IAQ}</p> 	<ul style="list-style-type: none"> • Integrated VOC Sensor • Our most complete, yet easy-to-use control system • Sleek design with backlight touchscreen LCD • ECO mode selects the best operating mode and speed for the season, minimizing energy use associated with ventilation • Set preferred indoor relative humidity range and ventilation mode for day and night conditions • No battery to replace, all programmed settings are retained during power outages • Maintenance reminder indicator • Error code messages reduce troubleshooting time 	
<p>ECO-Feel</p> 	<ul style="list-style-type: none"> • ECO mode selects the best operating mode and speed for the season, minimizing energy use associated with ventilation • Integrated VOC Sensor • No battery to replace, all programmed settings are retained during power outages 	

WALL CONTROLS (CONT'D)

EDF SERIES	FEATURES	CONNECTS TO
 <p>EDF7</p>	<ul style="list-style-type: none"> • MODE button provides 3 modes of operations: Ventilation , Recirculation and Standby • User selected fan speed: Reduced, Medium, Normal and 20 minutes per hour • AUTO setting allows the homeowner to deactivate the dehumidistat • When the humidity exceeds the desired setpoint, the ventilation system operates at normal speed • Once the desired humidity level is achieved, your ventilation system resumes to its previous mode of operation. 	
 <p>EDF1</p>	<ul style="list-style-type: none"> • Press button once for continuous Reduced speed • Press button twice and the unit will cycle 20 minutes ON/ 40 minutes OFF and repeat • EDF1 – Press button a third time and the system will run continuously on HIGH speed 	

AUXILIARY CONTROL –These controls can be paired with central controls or combined together.

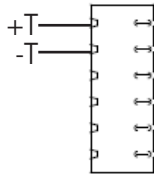
*Maintain polarity between control and HRV (+ → + ; - → -)

RTS SERIES	FEATURES	CONNECTS TO
	<ul style="list-style-type: none"> • Wireless timer • Can only be paired with the ECO-Touch^{IAQ} • 20/40/60 minute timer with LED light • Boosts system to high speed with the touch of a button • Up to 5 can be used in one system • Use in bathroom, kitchen, laundry room 	<p>Connects wirelessly to the</p> 
 <p>RTS2*</p>	<ul style="list-style-type: none"> • 20- minute timer with LED light • Boosts system to high speed with the touch of a button • Up to 5 can be used in one system • Use in bathroom, kitchen, laundry room 	
 <p>RTS5*</p>	<ul style="list-style-type: none"> • 20/40/60 minute timer with LED light • Boosts system to high speed with the touch of a button • Up to 5 can be used in one system • Use in bathroom, kitchen, laundry room 	

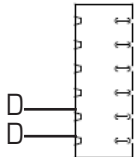
MDEH SERIES	FEATURES	CONNECT TO
 <p>MDEH1</p>	<ul style="list-style-type: none"> • Rotary dial Dehumidistat • Multiple units can be used • We recommend setting the relative humidity above 80% during the summer 	

WIRING DIAGRAM

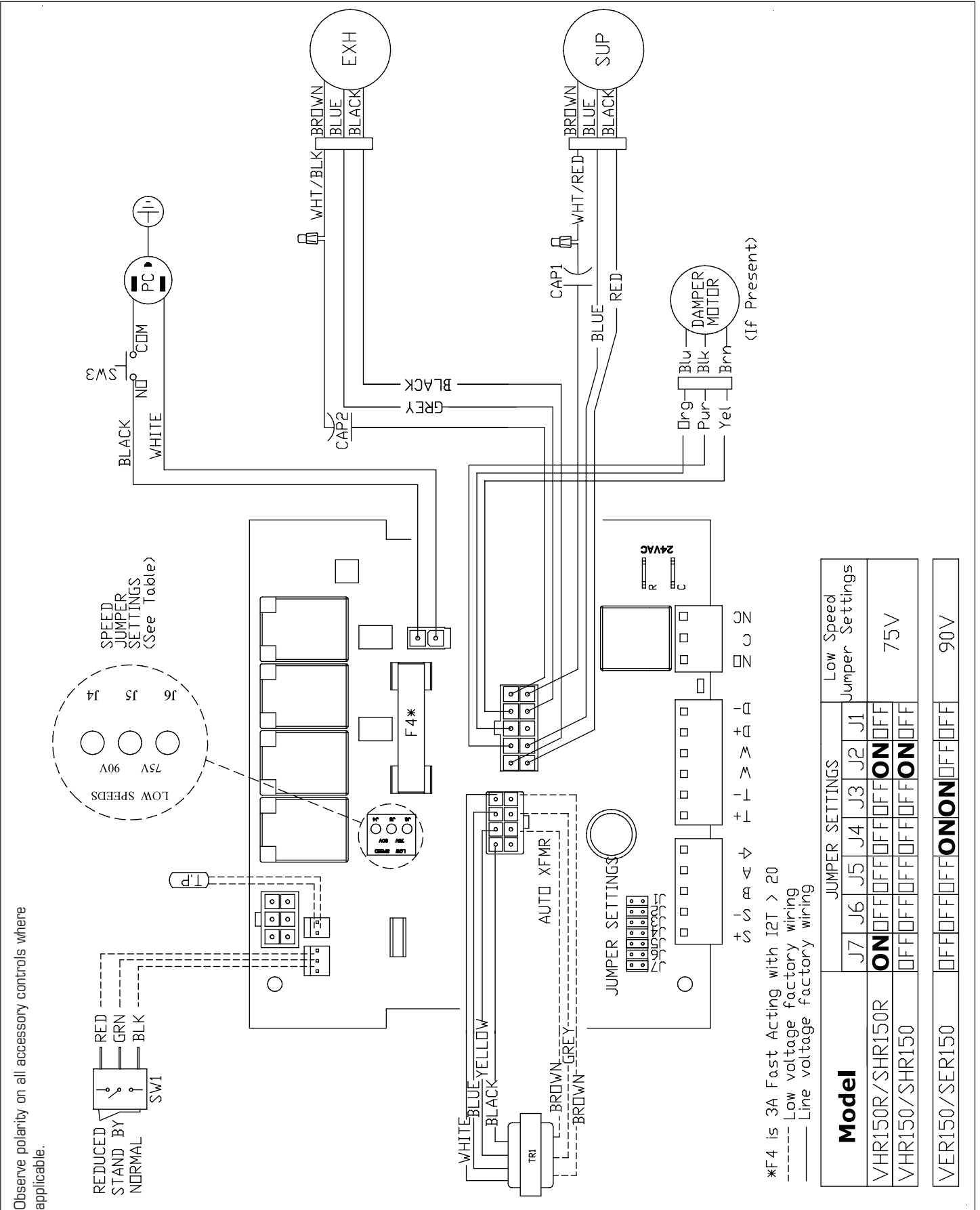

Observe polarity on all accessory controls where applicable.

REDUCED
STAND BY
NORMAL

RED
GRN
BLK

SW1

LOW SPEEDS

75V 90V

J6 J5 J4

SPEED JUMPER SETTINGS
(See Table)

*F4 is 3A Fast Acting with I2T > 20

--- Low voltage factory wiring

— Line voltage factory wiring

Model	JUMPER SETTINGS						Low Speed Jumper Settings
	J7	J6	J5	J4	J3	J2	J1
VHR150R/SHR150R	ON	OFF	OFF	OFF	OFF	OFF	ON
VHR150/SHR150	OFF	OFF	OFF	OFF	OFF	OFF	ON
VER150/SER150	OFF	OFF	OFF	OFF	OFF	OFF	ON
							75V
							90V

WIRING DIAGRAM (CONT'D)

WIRING DIAGRAM TO FURNACE



FOR A FURNACE CONNECTION TO A COOLING SYSTEM:

On some newer furnaces and older thermostats, energizing the R and G terminal at the furnace has the effect of energizing the Y at the thermostat and thereby turning on the cooling system. If you identify this type of thermostat, you must use the "Alternate Furnace Interlock Wiring"

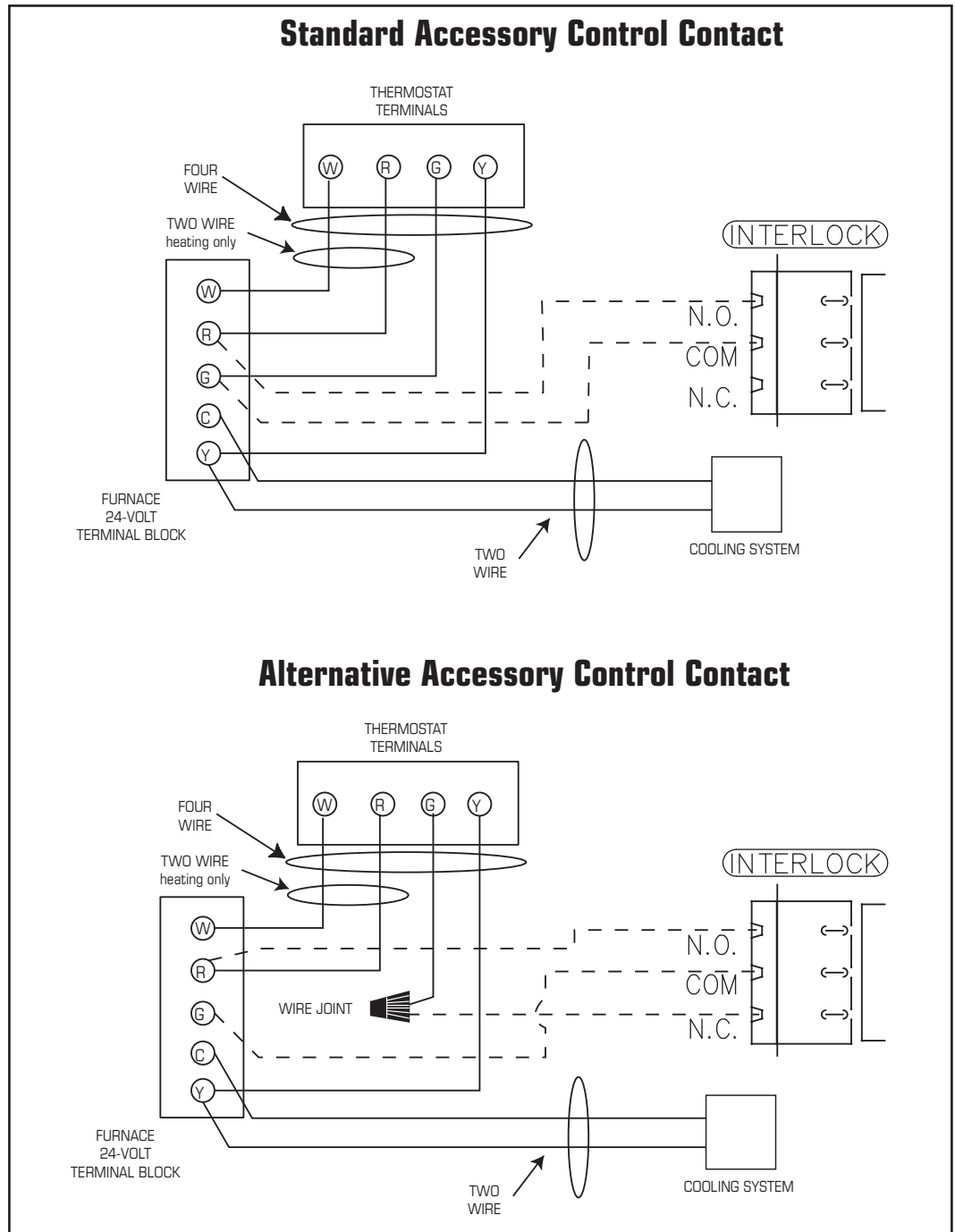

As per building codes and installation requirements for combustion appliances:
Air return ducts, or openings for air return, should not be placed in enclosed spaces containing combustion appliances that are subject to spillage.

TROUBLESHOOTING

Problem	Causes	Solutions
Air is too dry	Dehumidistat control is set too low	Increase the desired level of humidity. Change ventilation mode from continuous mode to standby.
	ERV out of balance	Have contractor balance ERV airflows
Air is too humid	Dehumidistat control is set too high	Reduce the desired level of humidity. Combine this with the use of continuous exchange mode.
	Sudden change in temperature	Wait until outside temperature stabilizes (winter). Heating will also improve situation.
	Storing too much wood for heating	Store a majority of your wood outside. Even dried, a cord of wood contains more than 20 gallons of water.
	Dryer vent exhaust is inside home	Make sure the dryer vent is exhausting outside.
	Poor air circulation near windows	Open curtains or blinds.
	ERV out of balance	Have contractor balance ERV airflows
	Well sealed basement door is closed	Open the door or install a grill on the door.
Persistent condensation on window	Improper adjustment of dehumidistat control	Reduce the desired level of humidity. Combine this step with use of continuous exchange mode.
	ERV out of balance	Have contractor balance ERV
	Poor air circulation near windows	Open curtains or blinds.
Poor Air Flows	1/4" (6mm) mesh on the outside hoods is plugged	Clean exterior hoods or vents
	Filters plugged	Remove and clean filter
	Core obstructed	Remove and clean core
	Indoor grilles closed or blocked	Check and open grilles
	Inadequate power supply at site	Have electrician check supply voltage
	Ductwork is restricting airflow	Check duct installation
	Improper speed control setting	Increase the speed of the ERV (i.e. change unit control from REDUCED to NORMAL speed)
	ERV airflow improperly balanced	Have contractor balance ERV airflows
	Ducting has fallen down or been disconnected from ERV	Have contractor reconnect ducting
Supply air feels cold	Poor location of supply grilles, the airflow may irritate the occupant	Locate the grilles high on the walls or under the baseboards, install ceiling mounted diffuser or grilles so as not to directly spill the supply air on the occupant (eg. Over a sofa) Turn down the ERV supply speed. A small duct heater (1kw) could be used to temper the supply air Placement of furniture or closed doors is restricting the movement of air in the home
	Outdoor temperature extremely cold	If supply air is ducted into furnace return, the furnace fan may need to run continuously to distribute ventilation air comfortably
ERV and/or Ducts frosting up	ERV air flows are improperly balanced	Have HVAC contractor balance the ERV airflows
	Malfunction of the ERV defrost system	Note: minimal frost build-up is expected on the core before unit initiates defrost cycle functions
Condensation or Ice Build Up in Insulated Duct to the Outside	Incomplete vapor barrier around insulated duct	Tape and seal all joints
	A hole or tear in outer duct covering	Tape any holes or tears made in the outer duct covering Ensure that the vapor barrier is completely sealed.

Note: It is best to get the unit checked by a certified HVAC Contractor/Technician.

ERV CORE WASHING INSTRUCTIONS

For proper maintenance of your energy recovery core please follow these instructions

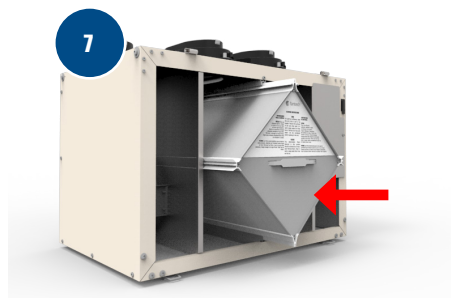
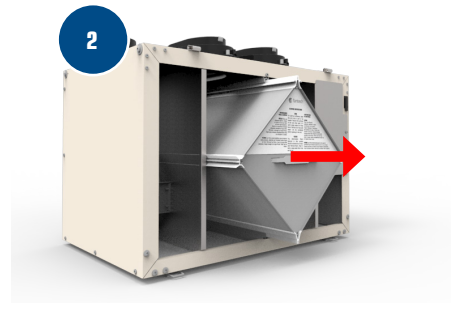
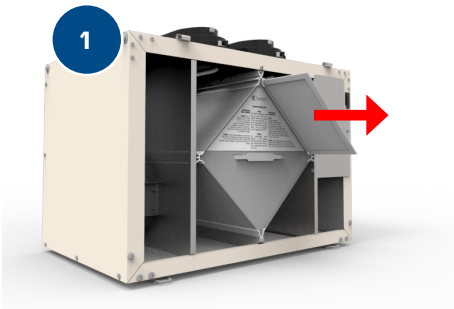

- 1 Remove both filters by sliding them out.
- 2 Remove the core from the unit.
- 3 With one of your core's air inlets facing down, place it in a large sink, bathtub, or shower.
- 4 Pour clean tap water through the face of the core facing upwards until it runs clear. Ensure the entire surface is rinsed.
- 5 Rotate the core so that its other air inlet is facing down and repeat step 5.
- 6 With plates still oriented vertically allow the core to dry, normally 2-3 hours.
- 7 Slide back the core into the unit
- 8 Replace both filters.

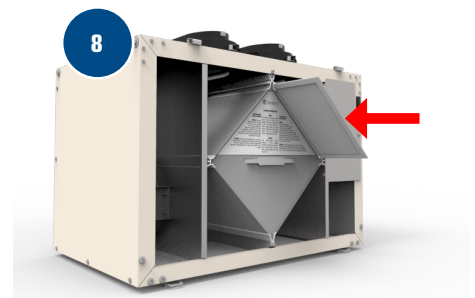

Limited Warranty

- The Energy recovery core has limited 5Y warranty.
- The warranty is limited to 5Y on parts and 7Y on fans from the date of purchase, including parts replaced during this time period. If there is no proof of purchase available, the date associated with the serial number will be used for the beginning of the warranty period.
- The fans found in all Fantech ERVs require no lubrication, and are factory balanced to prevent vibration and promote silent operation.

- The limited warranty covers normal use. It does not apply to any defects, malfunctions or failures as a result of improper installation, abuse, mishandling, misapplication, fortuitous occurrence or any other circumstances outside Fantech's control.
- Inappropriate installation or maintenance may result in the cancellation of the warranty.
- Any unauthorized work will result in the cancellation of the warranty.
- Fantech is not responsible for any incidental or consequential damages

incurred in the use of the ventilation system.

- Fantech is not responsible for providing an authorized service centre near the purchaser or in the general area.
- Fantech reserves the right to supply refurbished parts as replacements.
- Transportation, removal and installation fees are the responsibility of the purchaser.
- The purchaser is responsible to adhering to all codes in effect in his area.

* This warranty is the exclusive and only warranty in effect relative to the ventilation system and all other warranties either expressed or implied are invalid.

PARTS LIST

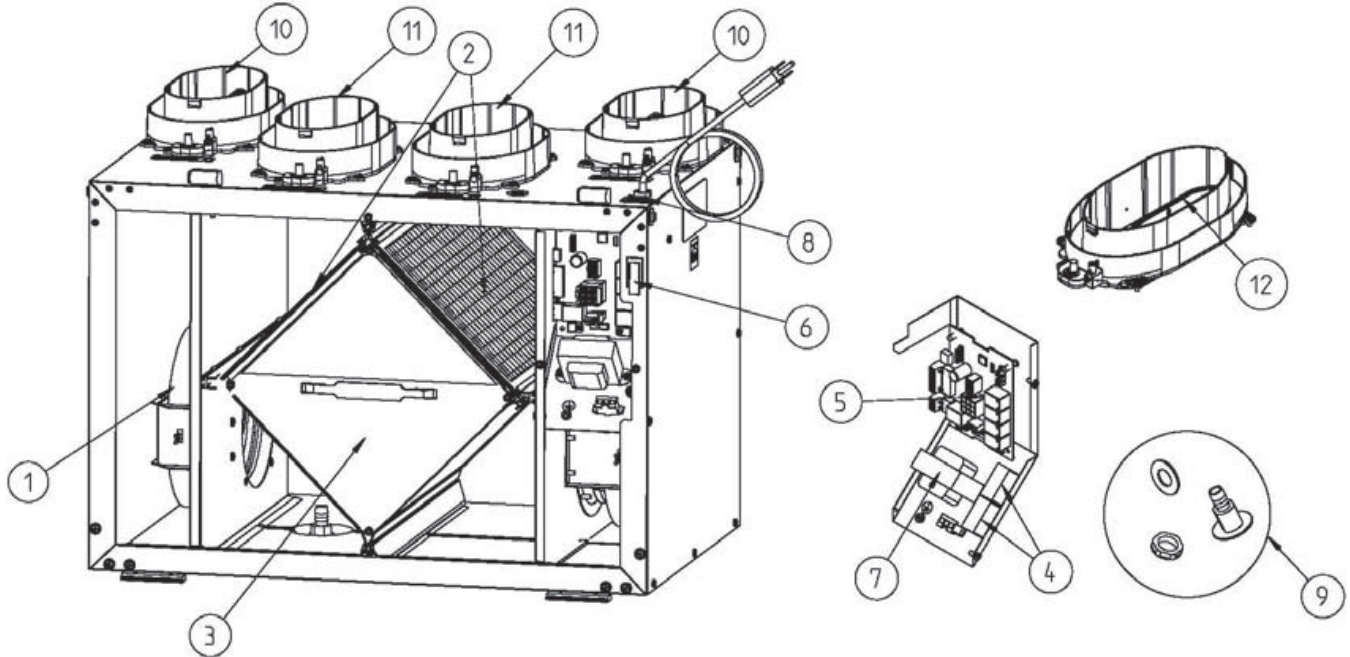

BOM #	Description	VER150 (463857)
1	LXFB2E190 Repl. motor kit	463995
2	Electrostatic Filters Kit 8.5" x 15"	402041
3	Energy Recovery Cell 9" x 9" x 15"	427473
4	Capacitors 8uF	410012
5	Kit,RV-CTRL Replacement,Board	428252
6	Door Switch	410867
7	Auto-Transformer	411963
8	Control Switch	410213
9	Kit Drain Plug	40315
10	Collar 6", Oval, w/Stop	413893
11	Collar 6", Oval, wo/Stop	413894
12	Damper Door, VHR150R	420462
	Temperature Probe	40286
	Door Assembly	445100
	Kit, Chain	404261
	Kit, Wall Bracket	426466
	KIT, FILTER, 2XMERV6, 8.5"X15"	414647

NOTES

NOTES

Fantech reserves the right to make technical changes.
For updated documentation please refer to www.fantech.net

Fantech se réserve le droit de faire des changements techniques. Pour de la documentation à jour, s'il vous plaît se référer au www.fantech.net

Fantech®