

The latest in home comfort UV AIR PURIFIERS

STANDARD

SINGLE UV
GERMICIDAL CLEANING



DELUXE

DUAL UV
GERMICIDAL CLEANING

PARABOLIC REFLECTOR



PREMIUM

DUAL UV
GERMICIDAL CLEANING

CARBON
ABSORBS ODORS

PCO
AIR TREATMENT



Now you can offer your customers an indoor air quality solution that's safe, effective, ozone-free, and incredibly affordable.

Help Disinfect, Deactivate and Treat Odors



Universal HVAC/R
Parts and Supplies



Universal HVAC/R
Parts and Supplies

UV LAMP UNITS

For Fan Coils and Gas Furnaces

Affordable ozone-free UV solutions that are easy to install.

Indoor Air

We typically spend a lot of our time indoors, most of which is at home. We like to believe that the air within our home is clean, but surprisingly enough, it usually is not. As home and building energy costs have risen there has been an increase in the need for airtight dwellings. The tightness while saving energy can help trap and concentrate indoor airborne pollutants. Airborne allergens can cover a wide spectrum including bacteria, virus, molds, odors, gases and chemical Volatile Organic Compounds (VOC's).

Microbes can easily travel through air with the potential to infiltrate, pollute and contaminate both air and contact surfaces. Some of these airborne and surface microbials can be toxic and unwanted in our living spaces. Certain bacteria, molds, virus and allergens can affect our well being. This modern problem has led to the development of new and innovative cleaning technologies to help cleanse and purify our indoor air.



UV AIR PURIFIER

Part Number Nomenclature

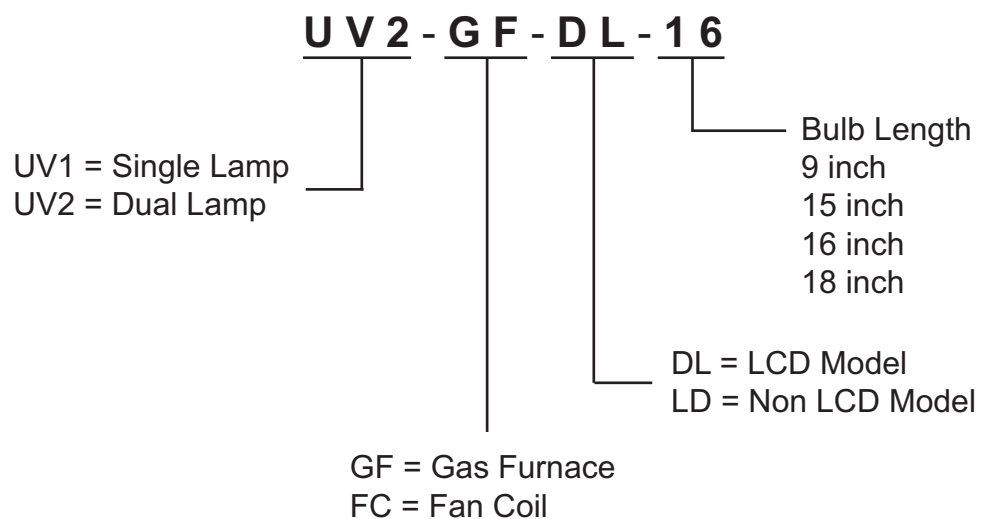

Table Of Contents

	Page
Part Number Nomenclature	2
Fan Coil Germicidal Air Purification Units	Page
STANDARD	
Ultra Violet Germicidal Air Purification Unit, Single Bulb Lamp	4
DELUXE	
Ultra Violet Germicidal Air Purification Unit, Dual Bulb Lamp	6
PREMIUM	
Ultra Violet Germicidal Air Purification Unit with Carbon Matrix and PCO, Dual Bulb Lamp	8
Gas Furnace Germicidal Air Purification Units	Page
DELUXE	
Ultra Violet Germicidal Air Purification Unit, Single Bulb Lamp	10
PREMIUM	
Ultra Violet Germicidal Air Purification Unit with Carbon Matrix and PCO, Dual Bulb Lamp	12
Ultra Violet Germicidal Air Purification Unit Replacement Bulb information	14
Definitions	15



Universal HVAC/R
Parts and Supplies

UV SINGLE LAMP UNIT

Fan Coil Germicidal Air Purification

SINGLE UV
GERMICIDAL CLEANING

Affordable ozone-free UV solutions that are easy to install.

STANDARD

The Totaline® Germicidal Air Purification unit is a convenient, non ozonating Ultra Violet Air Treatment System. It features a non ozonating, 254 nanometer UVC lamp with a magnetic base to allow quick & convenient retrofits. It includes a Delta plate option as well as convenient 24 volt connection. The UV Single Lamp Germicidal Purification System helps disinfect & deactivate airborne molds, bacteria, virus and microorganisms in addition to coil irradiation & surface treatment. Lamps are 9000 hours.

Features:

- **24 Volt Operation:**
Ideal for air handlers, fan coil or packaged units
- **Optimum output ballast:**
Maximized UVC output at 24 Volts
- **Available in 15" or 18":**
Multiple models for all applications
- **Magnetic mounting base:**
Solid grip for installation ease
- **Delta Plate option:**
For internal coil installation
- **Extended range ballast:**
For voltage variance 18 - 32 VAC
- **254 Nm UVC lamps:**
Ideal UVC output range
- **Ceramic lamp collars:**
Fast, convenient replacement

Helps Disinfect and Deactivate



5 Year Warranty
on unit.
1 Year Warranty
on lamps.

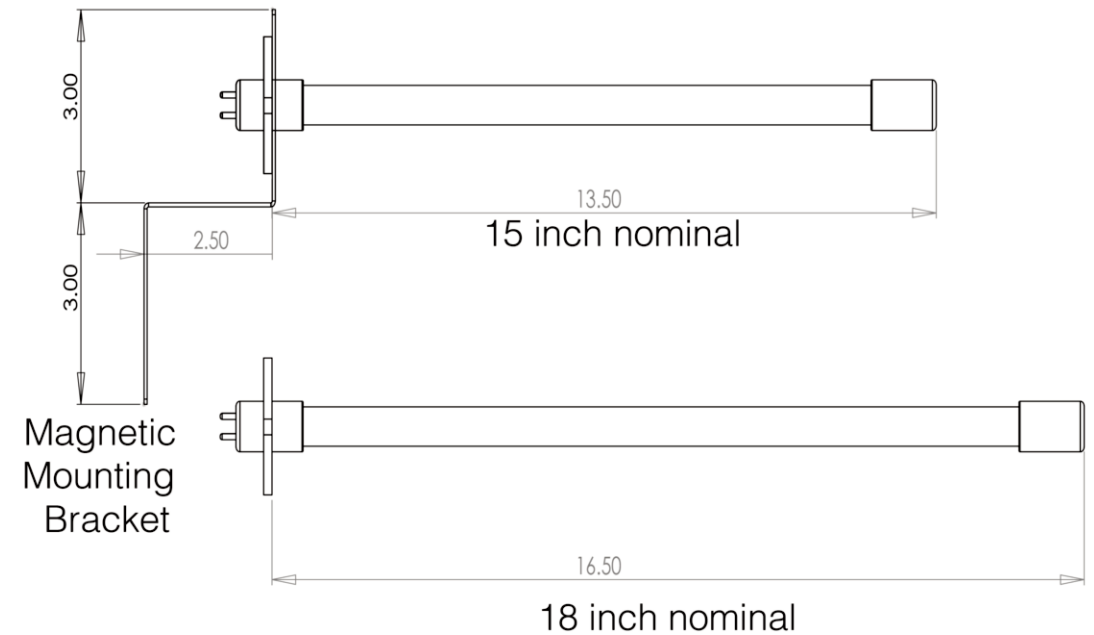

UV SINGLE LAMP SPECIFICATION CHART

Unit Model Number	Electrical Power	Lamp Length @ .75" Dia.	Replacement Lamp Number	Lamp Life (Hrs)	Lamp Wattage	Lamp Type	UV Output uw/cm at 2.5'	AMP Draw
UV1-FC-S-15	24V	15" (14.25")	UV1-FC-15CC-LP	9000	18 Watt	254 Nm	93	.75A
UV1-FC-S-18	24V	18" (17.25")	UV1-FC-18CC-LP	9000	23 Watt	254 Nm	145	1.0A

Unit supplied with magnetic mounting base, 24 volt ballast, 6 foot UV resistant power cord and all hardware



Universal HVAC/R
Parts and Supplies

UV DUAL LAMP UNIT

Fan Coil Germicidal Air Purification

DUAL UV
GERMICIDAL CLEANING

PARABOLIC REFLECTOR

Affordable ozone-free UV solutions that are easy to install.

DELUXE

The Totaline® Germicidal Air Purification unit is a potent UVGI, non-ozonating Ultra Violet air treatment system. It features non ozonating lamp, Dual 36 watt-254 nanometer UVC lamps, in combination with proprietary anodized aluminum parabolic reflectors. This tandem system helps enhance UVC output creating higher potency in a convenient and versatile design. Magnetic bases allow quick retrofit and are fully reversible for Delta plate installations. The Totaline Germicidal Purification unit helps disinfect & deactivate airborne molds, bacteria, virus and microorganisms in addition to coil irradiation & surface treatment. Lamps are 9000 hours.

Features:

- **24/120 Volt Operation:**
Ideal for air handlers, fan coil or packaged units
- **Magnetic Mounting Base**
4 post design for solid, quick grip
- **High UVC output:**
36 Watt with directional germicidal effect
- **Extended range ballast:**
For voltage variances
- **Delta 254 Nm UVC lamp:**
Twice the output versus single 18 watt lamp
- **Anodized parabolic reflector:**
Helps boost & direct UVC output
- **Delta plate option:**
Fully reversible for coil installations

Helps Disinfect and Deactivate



5 Year Warranty
on unit.
1 Year Warranty
on lamps.

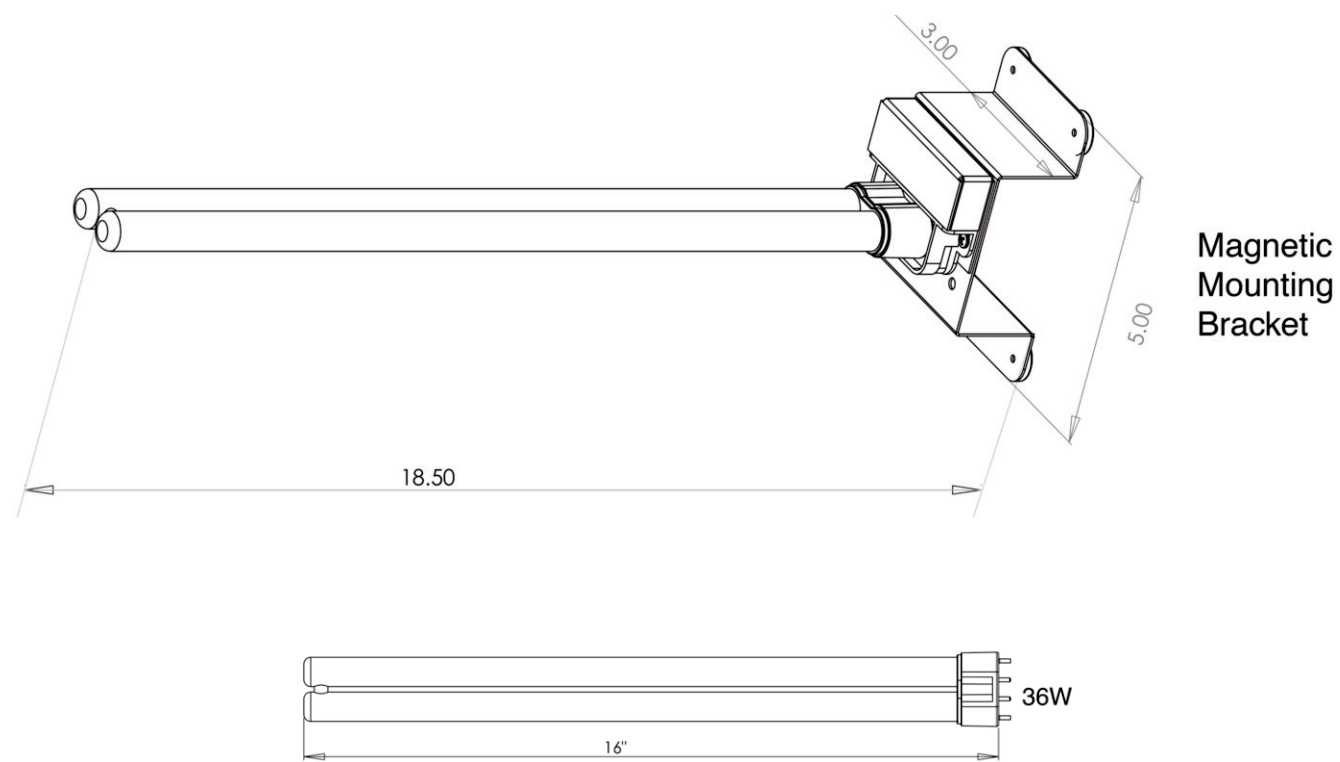

UV DUAL LAMP SPECIFICATION CHART								
Unit Model Number	Electrical Power	Lamp Length 2 @ .75" Dia.	Replacement Lamp Number	Lamp Life (Hrs)	Lamp Wattage	Lamp Type	UV Output uw/cm at 2.5'	AMP Draw
UV2-FC-D-16	24/120V	16" (15.25")	UV2-FC-16-LP	9000	36 Watt	254 Nm	204	1.5A/.35A

Unit supplied with parabolic reflector, magnetic mounting base, 24 volt ballast, 6 foot UV resistant power cord and all hardware



Universal HVAC/R
Parts and Supplies

UV DUAL LAMP UNIT

Fan Coil Germicidal Air Purification

PCO AIR TREATMENT CARBON ABSORBS ODORS DUAL UV GERMICIDAL CLEANING

PREMIUM

The **Totaline® Ultra Violet System with Carbon Matrix & PCO** is a unique indoor air treatment and odor absorption system. It utilizes **multiple processes to help reduce** airborne microorganisms, odors, gases and Volatile Organic Compounds (VOC's). This combination works on your air in **three distinct ways**. UVC Germicidal works on airborne bacteria, viruses & molds including coil treatment. The Carbon Matrix cells work to **absorb odors & VOC's** in combination with, the PCO Spiroplate Sterilizer oxidation system. This unique combination helps enhance air cleansing throughout the indoor living space. This technology is **ozone free** for a natural 3 way air cleansing process.

The Totaline® Ultra Violet system features 9000 hour UVC Germicidal lamps & replaceable matrix media's. Periodic maintenance & replacement is recommended.

Features:

- **Dual Voltage 24/120V operation:**
Ideal for air handlers, fan coil or packaged units
- **Dual 254 Nm, 36 watt lamps:**
Twice the power versus single lamp 18W
- **Tri-process air treatment:**
UVGI, Carbon absorptive matrix & PCO oxidation
- **Replaceable matrix & PCO:**
Ensures long term performance
- **Patented spiroplate sterilizer:**
Provides for coil irradiation and air treatment
- **Magnetic mounting base:**
Easy installation & servicing
- **Ozone free:**
Optimized for safety

Helps Disinfect, Deactivate and Treat Odors



UV DUAL LAMP SPECIFICATION CHART

Unit Model Number	Electrical Power	Lamp Length 2 @ .75" Dia.	Replacement Lamp Number	Lamp Life (Hrs)	Lamp Wattage	Lamp Type	UV Output uw/cm at 2.5'	AMP Draw
UV2-FC-P-16	24/120V	16" (15.25")	UV2-FC-16-LP	9000	Dual 36 Watt	254 Nm	204	1.5A/.35A

Unit supplied with Patented SpiroPlate Sterilizer, Carbon Matrix Tray, magnetic mounting base, 24 volt ballast, 6 foot UV resistant power cord and all hardware

Affordable ozone-free UV solutions that are easy to install.

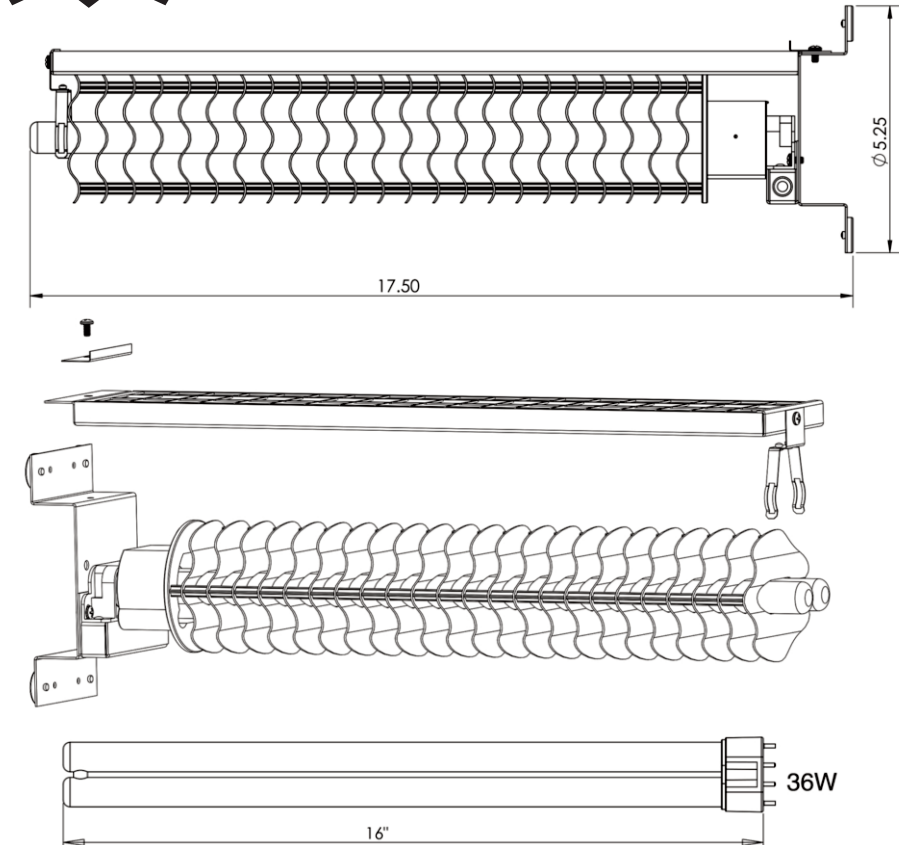

Universal HVAC/R
Parts and Supplies

UV DUAL LAMP UNIT

Gas Furnace Germicidal Air Purification

DUAL UV
GERMICIDAL CLEANING

PARABOLIC REFLECTOR

Affordable ozone-free UV solutions that are easy to install.

DELUXE

The Totaline Dual Lamp UV unit is a potent UVGI, Germicidal Ultra Violet air treatment system. It features non ozonating, Dual 36 watt-254 nanometer UVC lamps, in combination with proprietary anodized parabolic reflectors. This tandem system helps enhance UVC output creating higher potency in a convenient & versatile design. The Totaline Germicidal unit helps disinfect & deactivate airborne molds, bacteria, virus and microorganisms in addition to coil treatment.

The Totaline Dual Lamp UV system features 9000 hours UVC Germicidal lamps. Periodic maintenance & replacement is recommended.

Features:

- **120 Volt operation:**
Ideal for duct systems
- **Dual 254 Nm, 36 watt lamps:**
Twice the power versus single lamp 18 watt
- **Enhanced with parabolic reflection:**
360 Degree directional UVC power
- **Optional LCD Service screen:**
Programmable & communicates
- **High temp "attic" model:**
For high ambient installations
- **UVC "Smart light" indicator:**
Monitors unit operation visually
- **Versatile mounting base:**
Convenient installation & servicing
- **Ozone free:**
Optimized for safety

Helps Disinfect and Deactivate



UV DUAL LAMP SPECIFICATION CHART								
Unit Model Number	Electrical Power	Lamp Length 2 @ .75" Dia.	Replacement Lamp Number	Lamp Life (Hrs)	Lamp Wattage	Lamp Type	UV Output uw/cm at 2.5'	AMP Draw
UV2-GF-D-16	120V	16" (15.25")	UV2-GF-16S-LP	9000	18 Watt	254 Nm	204	.35A
UV2-GF-DL-16*	120V	16" (15.25")	UV2-GF-16S-LP	9000	18 Watt	254 Nm	204	.35A

Unit supplied with parabolic reflector.

* Includes LCD option



5 Year Warranty
on unit.
1 Year Warranty
on lamps.

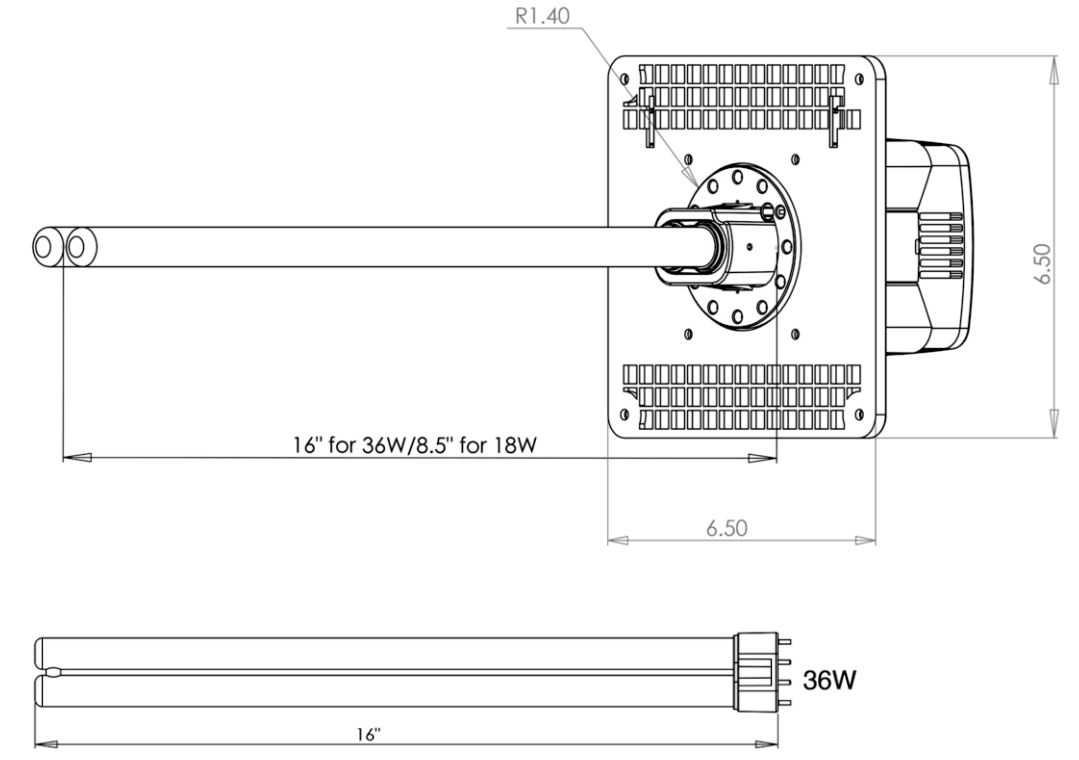

**Universal HVAC/R
Parts and Supplies**

UV DUAL LAMP UNIT

Gas Furnace Germicidal Air Purification

PCO AIR TREATMENT CARBON ABSORBS ODORS DUAL UV GERMICIDAL CLEANING

PREMIUM

The **Totaline® Ultra Violet System with Carbon Matrix & PCO** is a unique indoor air treatment and odor absorption system. It utilizes **multiple processes to help reduce** airborne microorganisms, odors, gases and Volatile Organic Compounds (VOC's). This combination works on your air in **three distinct ways**. UVC Germicidal works on airborne bacteria, viruses & molds including coil treatment. The Carbon Matrix cells work to **absorb odors & VOC's** in combination with, the PCO Spiroplate Sterilizer oxidation system. This unique combination helps enhance air cleansing throughout the indoor living space. This technology is **ozone free** for a natural 3 way air cleansing process.

The Totaline® Ultra Violet system features 9000 hours UVC Germicidal lamps & replaceable matrix media's. Periodic maintenance & replacement is recommended.

Features:

- **Dual Voltage 24/120V operation:**
Ideal for ducted systems
- **Dual 254 Nm, 36 watt lamps:**
Higher UVC output
- **Tri-process air treatment:**
UVGI, absorption & oxidation
- **Large, active surface area:**
Enhanced odor & gas treatment
- **Replaceable carbon & PCO matrix:**
Ensures long term performance
- **"Smart light" system indicator:**
Confirms operation visually
- **Microprocessor LCD display:**
Programmable & communicates
- **High temperature models:**
For high ambient installations
- **Ozone free:**
Optimized for safety

Helps Disinfect, Deactivate and Treat Odors



UV System with Carbon Matrix & PCO Specification Chart									
Unit Model Number	Electrical Power	High Temp.	LCD Option	Replacement Lamp Number	Lamp Hours	Lamp Type	AMP Draw	PCO HC Trays	Carbon HC Trays
UV2-GF-P-09	24/120V	Yes	No	UV2-GF-09S-LP	9000	254 Nm	1.5A/.35A	9" (1)	9" (2)
UV2-GF-PL-09	24/120V	No	Yes	UV2-GF-09S-LP	9000	254 Nm	1.5A/.35A	9" (1)	9" (2)
UV2-GF-P-16	120V	Yes	No	UV2-GF-16S-LP	9000	254 Nm	.35A	16" (2)	16" (4)
UV2-GF-PL-16	120V	No	Yes	UV2-GF-16S-LP	9000	254 Nm	.35A	16" (2)	16" (4)

Affordable ozone-free UV solutions that are easy to install.



5 Year Warranty
on unit.
1 Year Warranty
on lamps.

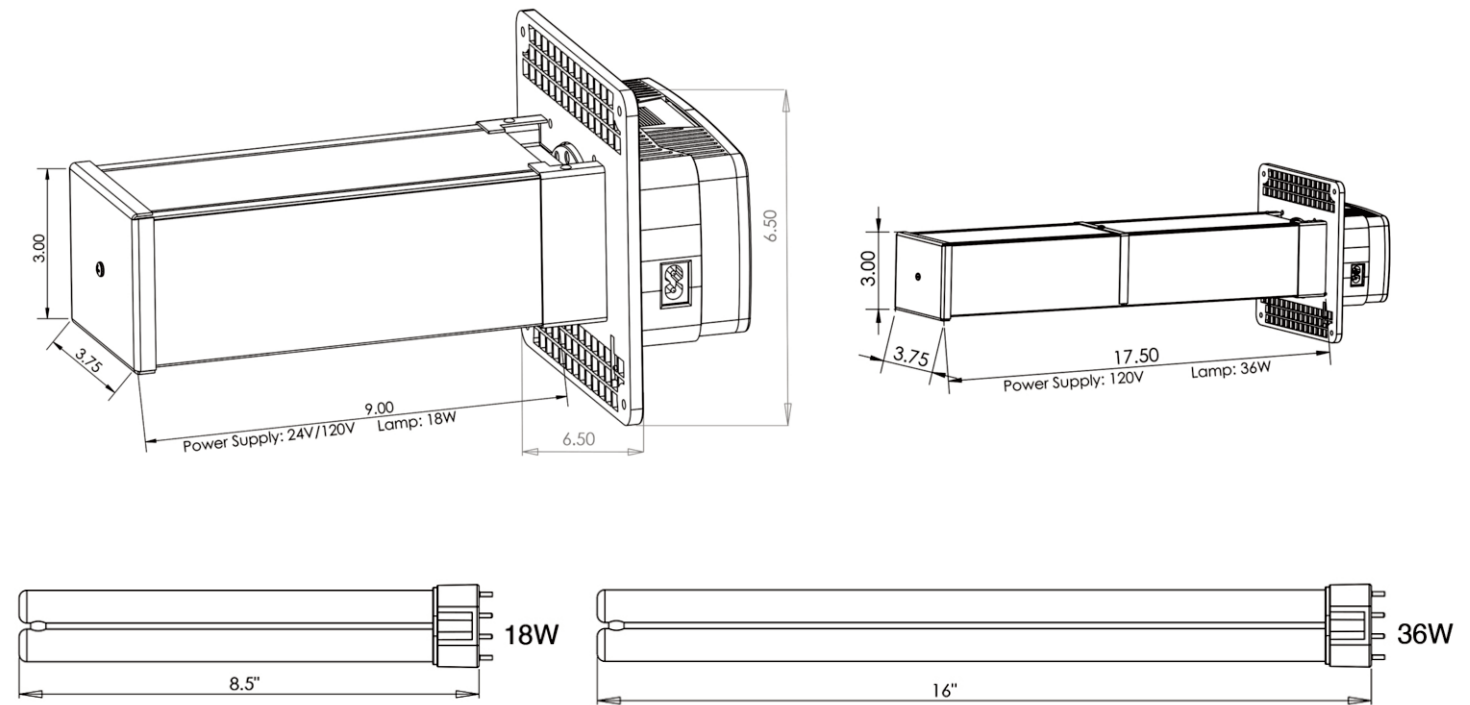

Universal HVAC/R
Parts and Supplies

UV LAMP UNITS

For Fan Coils and Gas Furnaces

Affordable ozone-free UV solutions that are easy to install.

UV Germicidal Air Purification Unit Replacement Bulb information

Control Module with USB	UV Unit Part Number	Description	Bulb Length (inches)	Power (volts)	Replacement Bulb Part Number
Fan Coil Units					
No	UV1-FC-S-15	UV - Single Lamp, 15"	15	24V	UV1-FC-15CC-LP
No	UV1-FC-S-18	UV - Single Lamp, 18"	18	24V	UV1-FC-18CC-LP
No	UV2-FC-D-16	UV - Dual Lamp with Parabolic Reflector	16	24/120V	UV2-FC-16-LP
No	UV2-FC-P-16	UV - Dual Lamp with Carbon & PCO	16	24/120V	UV2-FC-16-LP
Gas Furnace Units					
Yes	UV2-GF-D-16	UV - Dual Lamp with Parabolic Reflector, High Temp	16	120V	UV2-GF-16S-LP
Yes	UV2-GF-DL-16	UV - Dual Lamp with Parabolic Reflector and with LCD	16	120V	UV2-GF-16S-LP
Yes	UV2-GF-P-09	Tri-system (UV + Carbon + PCO), High Temp	9	24/120V	UV2-GF-09S-LP
Yes	UV2-GF-PL-09	Tri-system (UV + Carbon + PCO), with LCD	9	24/120V	UV2-GF-09S-LP
Yes	UV2-GF-P-16	Tri-system (UV + Carbon + PCO), High Temp	16	120V	UV2-GF-16S-LP
Yes	UV2-GF-PL-16	Tri-system (UV + Carbon + PCO), with LCD	16	120V	UV2-GF-16S-LP



Universal HVAC/R
Parts and Supplies