

# APCO-X

AIR TREATMENT SYSTEM

APCO-X reduces odors (VOCs) and biological contaminants such as mold, bacteria, viruses, and allergens in indoor air. The system is installed in the duct work of the central air system. The award-winning design of APCO-X uses a unique combination of UVC light and activated carbon cells to clean the air.

US patent #7,704,463



### IMPORTANT!

- Only qualified technicians should install this product\*
- Install in accordance with relevant building codes
- Read instructions carefully including safety warnings

### WARNING!

PROTECT EYES FROM UV LIGHT  
TURN OFF UNIT OR DISCONNECT  
BEFORE SERVICING

\*Installation of this product by anyone other than licensed HVAC or electrical contractors voids warranty.  
© Fresh-Aire UV LIT-FAUV-APCO-X-MAN 080422

## Parts List

- A Main Unit
- B UV Lamp (3 Year)
- C Duct Plate
- D Gasket
- E Thumb Screws (on cover)
- F Power Cord (ER/DER Models)
- G Self-tapping Screws
- H Quick Nut (plastic)
- I Tap-in Connector (ER/DER Models)
- J Spade Connector (SI/DI Models)

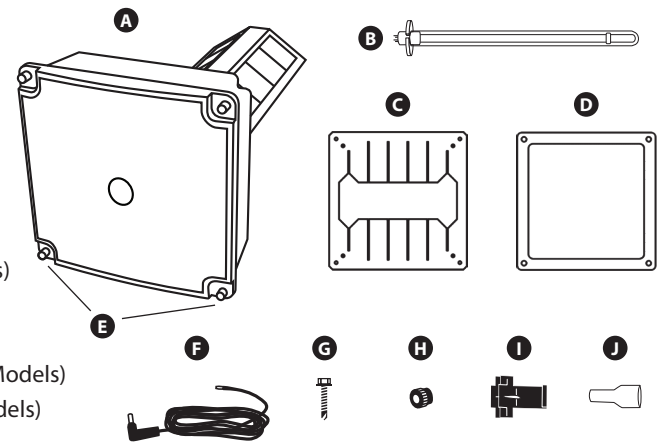

Dual system only

- K Secondary UV Lamp (3 Year)
- L Magnet Bracket
- M Warning Sticker
- N Sight Glass

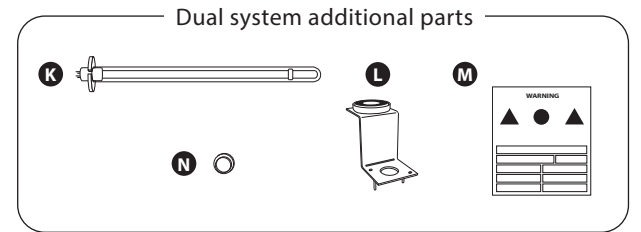

## 1 Installation Notes

The air treatment system is usually installed on the supply side duct just above the air system (upstream of a humidifier if there is one) but can also be installed on the return side if necessary.

The main unit should be oriented so that the air flows past the UV Light first then into the Matrix Element. Position the main unit so the UV light does not shine directly on non-uv-resistant materials (filters, humidifiers, flex duct, etc) and if possible orient it so UV light shines on the cooling coil.

When installing a dual system (a second remote UV Lamp) select a location inside the air system that will allow it to shine on the greatest surface area or the area with the most evident microbial growth. To install the secondary UV light use the Secondary UV Light Installation Instructions on the next page.

### LED Status Indicator

Blue = Lamp status good  
Red = Lamp status out

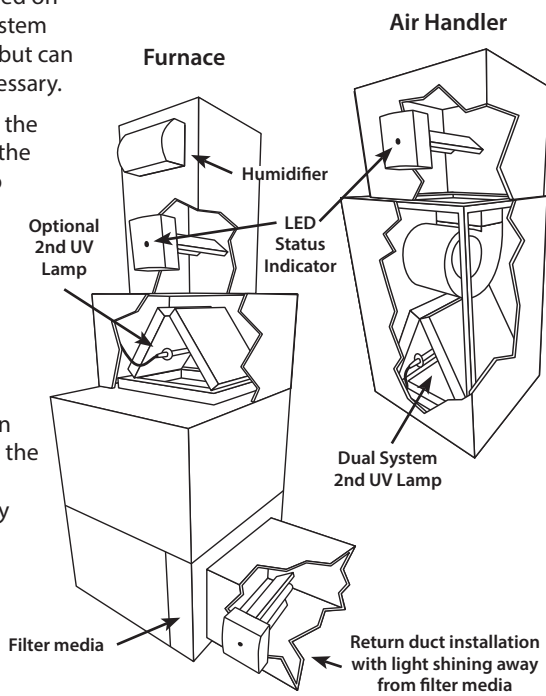

## 2 Duct Mounting

1. Use gasket to trace cut-line onto duct.
  2. Cut hole in sheet metal or duct board. **IMPORTANT! Remove and dispose of cut-out piece of material.**
  3. For sheet metal duct secure mounting plate with Self-tapping Screws G.\*
  4. Remove paper backing from one side of gasket and fix gasket to the back of the mounting plate.
  5. Remove paper backing from back of gasket then fix mounting plate and gasket to the duct.
  6. Bend mounting plate flanges around the edges of the hole to secure mounting plate. For duct board use tape on edges of mounting plate for air leaks and additional hold.
- \* If the backing plate can't be used install directly with 4 Self-tapping Screws G.

## 3 Attach Power Unit to Duct & Mount UV Lamp

1. Fit the Main Unit through hole in duct. If attaching directly to metal duct use 4 Self-tapping Screws G. If the Backing Plate is used fit the unit over the threaded posts and use 4 Quick Nuts H to secure it.
2. Insert UV Lamp.
3. Mount UV Lamp using 2 Quick Nuts H and attach lamp connector (be sure to align the four connector pins).
4. Rotate the cover so it is oriented correctly then attach with thumb screws.

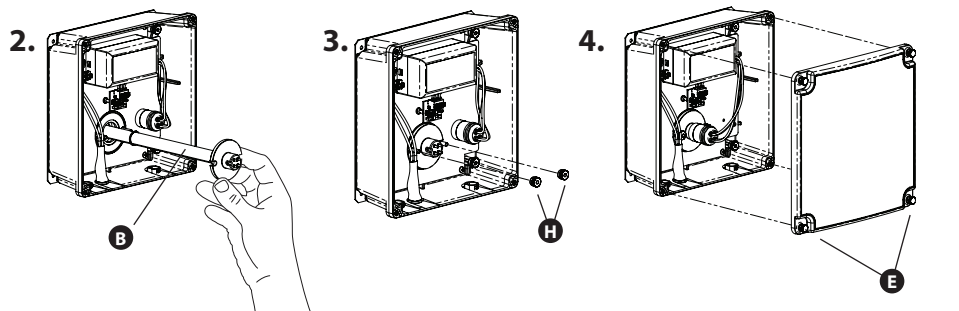

## 4 Connecting to Power

### IMPORTANT

Before connecting to power confirm which model is being installed. Turn off main power source before installation. Always use proper conduit fittings and terminations. Model information is printed on the Power Unit cover.

**IMPORTANT! Must be wired to constant power - do not connect to blower relay.**

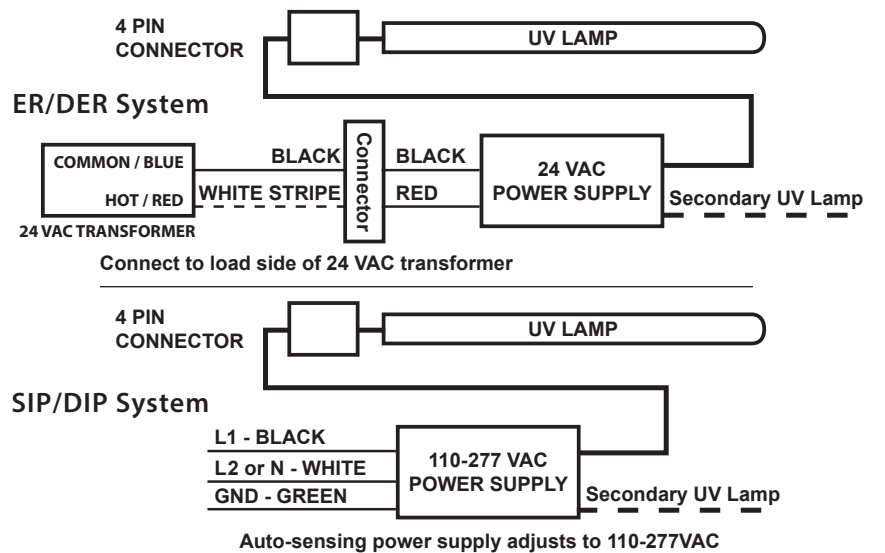

### IMPORTANT!

Systems with high 24 VAC loads may require the installation of a separate 24 VAC transformer to power the UV light.

Always use a separate 24 VAC transformer with "communicating" air systems and with all Dual System models.

Draws 16 VA, may need to do load calculation: Volts under load X Amps under load.

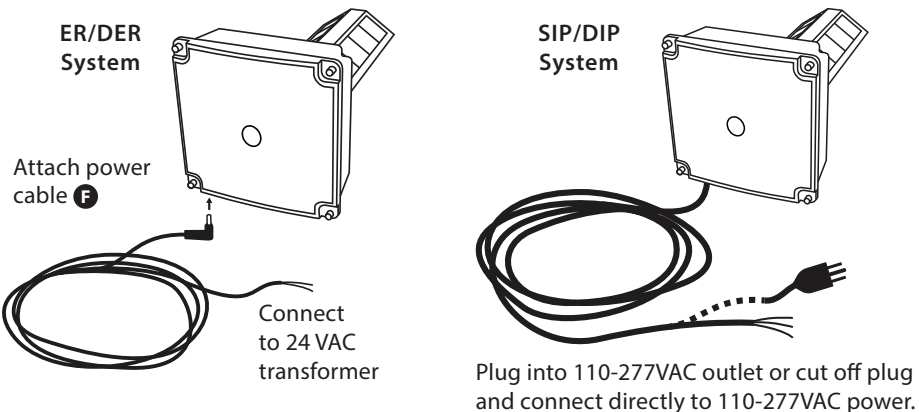

Power cord plug can be removed to expose lead wires for hard wire applications and will retain Intertek ETL Certification.

## 5 Lamp Replacement

The UV lamp in the Air Treatment System (model TUVL- 315) should be replaced every 3 years. Note: UV lamps will continue to emit visible light but lose germicidal effectiveness over time.

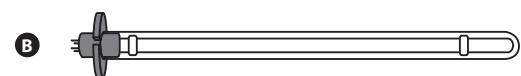

TUVL-315



### CAUTION!

UV lamps contain small amounts of mercury - dispose of lamps in accordance with local environmental regulations. For more information visit [www.lamprecycle.org](http://www.lamprecycle.org)

**Note: Note:** Use of replacement UV lamps other than TUVL- 315, TUVL- 215, or TUVL- 115 voids warranty.

# Dual System Secondary UV Light Installation Instructions

The Secondary UV Light (included with dual air treatment systems) is typically installed at the coil for enhanced germicidal effectiveness, reduced system maintenance, and improved indoor air quality.

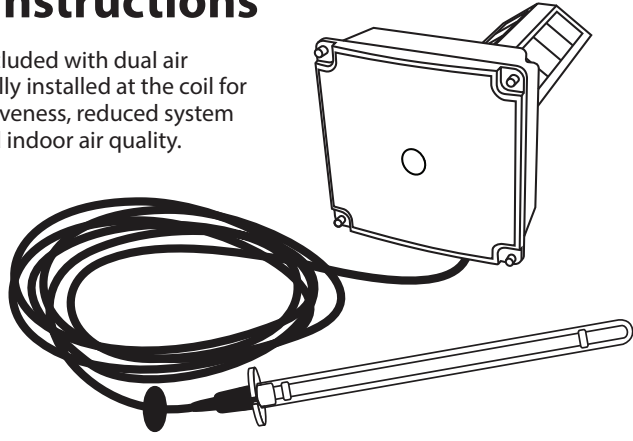

**IMPORTANT!**

- Dual System lamps are wired in series - connect both for lamps to light
- Only qualified technicians should install this product
- Install in accordance with relevant building codes
- Read instructions carefully including safety warnings

## Installation Notes

Before installing the Secondary UV Light it is necessary to determine the optimal mounting location inside the air system. First, look for the area with the heaviest mold growth. Also consider a location that will allow the germicidal UV Light to shine on the greatest surface area.

Some typical mounting locations:

- a** Across top of coils
- b** Coil "A" plate
- c** Return-side duct



**Important:** Some materials inside the air system (including filter media, flex duct, wiring etc) may not be UV light resistant. Use the optional UV shield (part #TUV-SHIELD-LPC) or cover the materials with reflective tape.

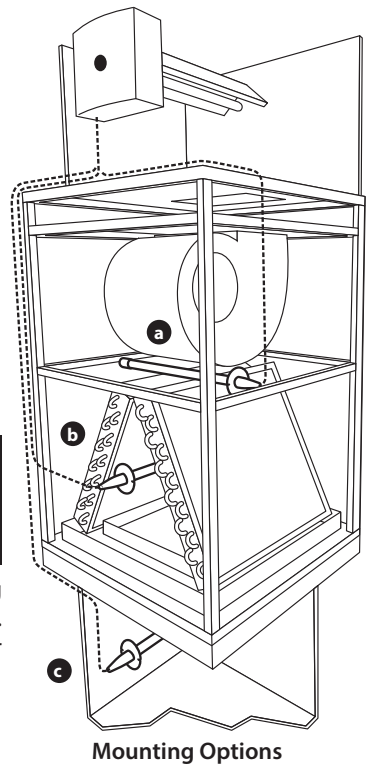

Mounting Options

## 1 Air Handler Interior Surface Installation

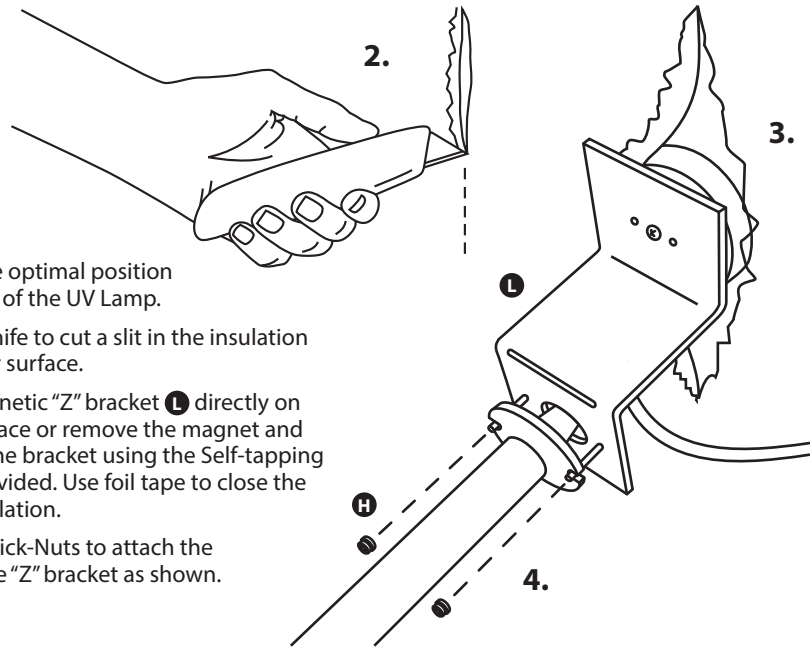

1. Determine the optimal position for placement of the UV Lamp.
2. Use a utility knife to cut a slit in the insulation on the interior surface.
3. Place the magnetic "Z" bracket **L** directly on the metal surface or remove the magnet and hard-mount the bracket using the Self-tapping Screws **H** provided. Use foil tape to close the cut in the insulation.
4. Use plastic Quick-Nuts to attach the UV lamp to the "Z" bracket as shown.

## 2 Coil "A" plate or Duct Installation

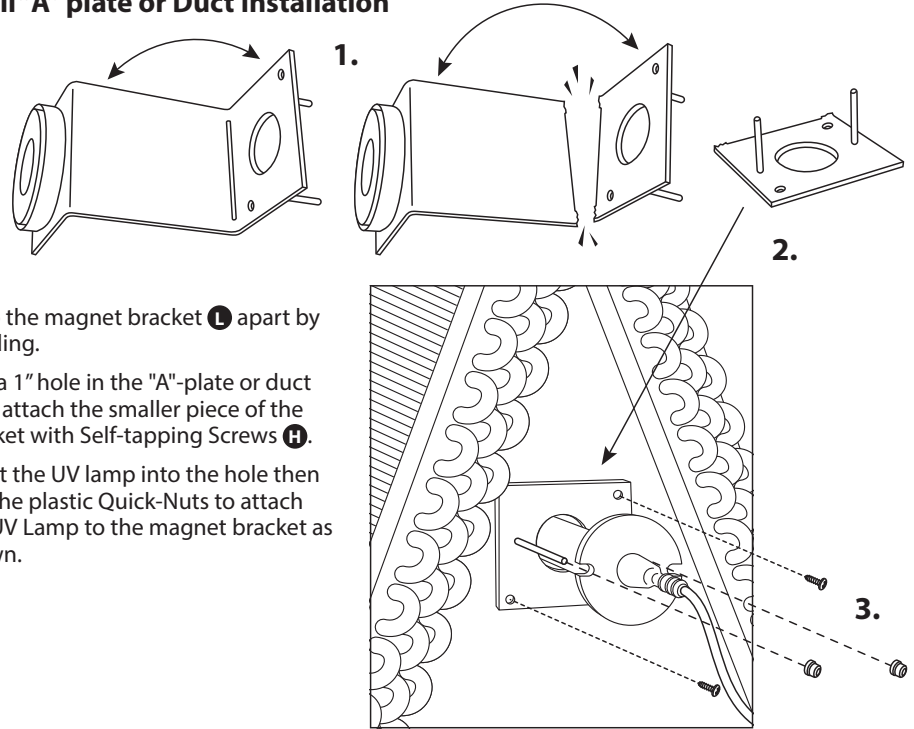

1. Snap the magnet bracket **L** apart by bending.
2. Drill a 1" hole in the "A"-plate or duct then attach the smaller piece of the bracket with Self-tapping Screws **H**.
3. Insert the UV lamp into the hole then use the plastic Quick-Nuts to attach the UV Lamp to the magnet bracket as shown.

## 3 Remote UV Light Configuration

**IMPORTANT!** Only Dual System models have the electrical capacity and attached cable to power the Secondary UV Light.

Find the secondary lamp cable on the right underside of the Dual System Main Unit.

Drill a 1" hole in the air system housing then pass the lamp cable through the hole. The hole is then sealed with the rubber grommet to minimize air leakage.

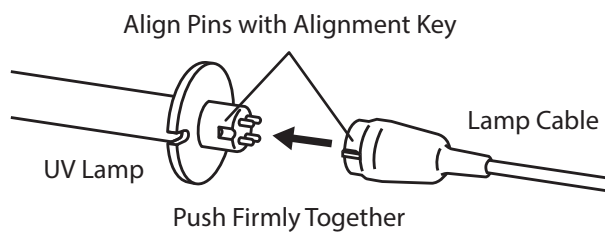
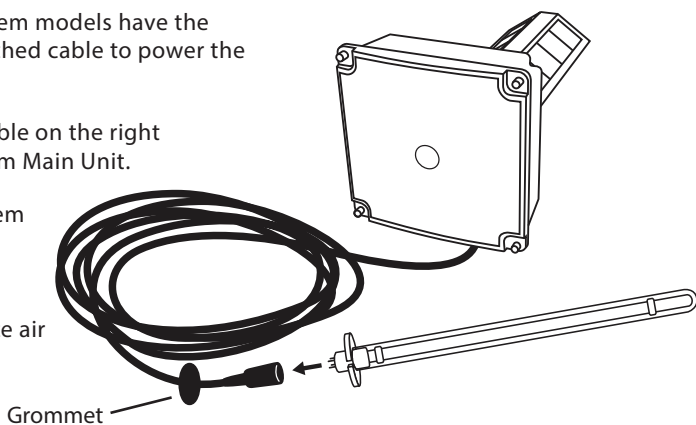

## 4 Sight Glass Installation

1. Find a suitable location on the outside of the duct-work near the UV Lamp installation and apply the warning/lamp replacement sticker **M**.
2. Drill a 1/2" hole through the circle on the sticker. Press the sight glass **N** into hole.
3. Turn on the power and use the sight glass to confirm that the UV Lamp is operating.

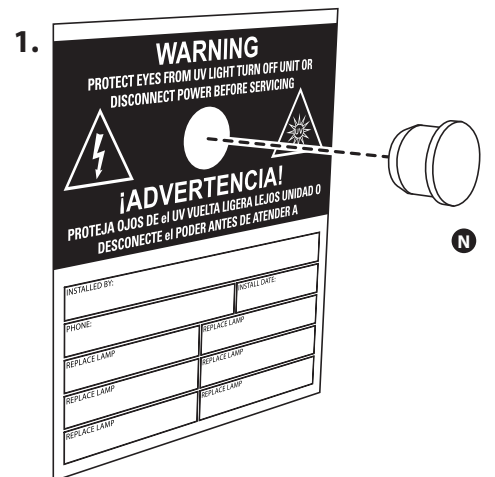

## 5 Lamp Replacement

The second germicidal UV Lamp **K** should be replaced every three years along with the primary lamp.

**Note:** UV lamps may continue to emit visible light after three years, however, germicidal effectiveness falls off over time and will quickly drop to near zero after three years.



TUVL-315



### CAUTION!

UV lamps contain small amounts of mercury - dispose of lamps in accordance with local environmental regulations. For more information visit [www.lamprecycle.org](http://www.lamprecycle.org)

**Note: Note:** Use of replacement UV lamps other than TUVL- 315, TUVL- 215, or TUVL- 115 voids warranty.