

Central Control Device

SERVICE MANUAL

Touch screen controller

Model name:

BMS-CT2560U-UL

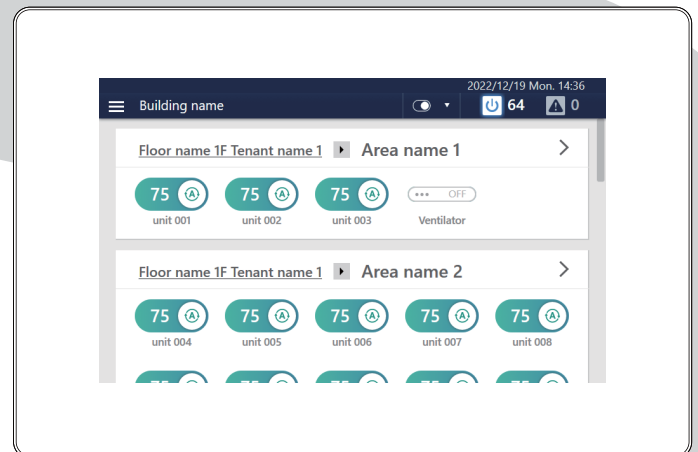
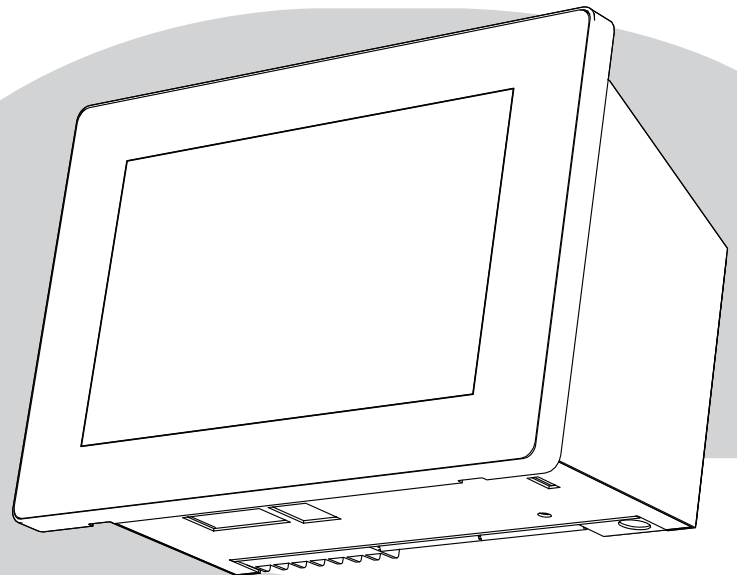





Contents

Safety Precautions	3
1 Product Overview	5
2 System Configuration	42
3 Initial Settings	44
4 Troubleshooting	64
5 Service Parts	76
Installation Manual	
Owner's Manual	
Section Configuration Software	
Energy Report Software 2	

Safety Precautions

- This section explains safety precautions you must follow in order to prevent harm to the user and other persons and damage to property.
- "Display Description" explains the classification of the degree of harm or damage that may occur if the unit is handled incorrectly, while "Symbol Description" indicates the meanings of symbols.

Display Description	Symbol Description
 WARNING Indicates "Content that is expected to result in death or serious injury (*1) to the user in the case of incorrect handling".	 ⚡ indicates prohibited actions. Specifically prohibited contents are indicated with a picture and/or text in or near the symbol.
 CAUTION Indicates "Content that is expected to result in minor injury (*2) to the user or damage to property (*3) in the case of incorrect handling".	 ● indicates instructions which must be followed. The actual contents of the instructions are indicated with a picture and/or text in or near the symbol.

* 1: Serious injury refers to lasting after effects such as blindness, injury, burns (high temperature / low temperature), electric shock, bone fracture, or poisoning, etc. and injuries that require hospitalization/long-term outpatient treatment.

* 2: Minor injury refers to injuries, burns, or electric shocks, etc. that do not require hospitalization or long-term outpatient treatment.

* 3: Damage to property refers to extended damage related to houses, household goods, livestock, or pets, etc.

WARNING



Turning off the circuit-breaker

- **Set the circuit-breaker to "OFF" before starting work**
Failing to do so may result in a high-voltage electric shock, leading to death or injury.



Prohibited

- **Do not turn on the circuit-breaker when the cover is removed**
Doing so may result in a high-voltage electric shock leading to death or injury.

CAUTION



Check earth connection

- **Check that the earth wire (*) is connected to the unit earth terminal before beginning troubleshooting and repair work**
If the earth wire is not connected, there is the risk of electric shock in the event of an electric leakage occurring.



Modification prohibited

- **Do not modify the product**
Also, do not disassemble or modify the parts.
Doing so may cause fire, electric shock, or injury.



Children must be kept away

- **Only qualified engineers should be allowed on a troubleshooting or repair work site. Children and all other third parties must be kept away**
There is a risk of injury from tools or disassembled parts.
Inform the customer that children and other third parties must be kept away from the work site.



Insulation

- **After connecting a crimp terminal to a cut lead wire, place the closed-end facing up and clean it**
If connections are not properly processed, electrical leakage, ignition or other accident could occur on the customer's premises.



Wiring Precautions During Assembly

- **After repairs are complete, be sure to reassemble the disassembled parts and connect and route the wires to restore the equipment to its original state. Make sure internal wires are not trapped in the cabinets, panels, or other parts**
An assembly or wire connection problem may result in a short circuit, ignition or other accident on the customer's premises.



Insulation check

- **After the work is completed, be sure to test between the live and dead metal parts (earth terminal) with an insulation resistance tester (500 V) to confirm that the insulation resistance is 2 MΩ or higher**

A low insulation resistance value may result in a short circuit, electric shock or other accident on the customer's premises.



Risk of electric shock

- **If you have to inspect a circuit that is energized, for example, take precautions such as wearing rubber gloves to avoid direct contact with a live part**

Touching a live part may result in an electric shock.



Check after repair

- **Check that there are no abnormalities after completing the repair work**

Failure to perform this check may result in fire, electric shock, or injury.

Turn off the earth leakage breaker before performing an inspection.

- **After completing the repair work, perform a test run and check that there are no abnormalities such as smoke or unusual noise**

Failure to perform this check may result in fire or electric shock.

Perform a test run after installing the front panel and cabinets.



Repair and reinstallation work

- **Installation and reinstallation work should be performed by your vendor or a qualified electrician**

Attempting to carry out installation work on your own, and doing so incorrectly, may result in electric shock or fire.

1 Product Overview

1-1. Function list

Specifications

Detailed specifications

Power supply	AC 120 V 60 Hz
Consumed current	1.17 A
Operating temperature/ humidity range	32 to 104°F(0°C to 40°C), 10% to 90% RH (no dew condensation)
Dimensions (mm)	H5.35"×W8.07"×D0.39" (H136 mm×W205 mm×D10 mm)(+3.15" (+80 mm)) (Embedded dimensions shown in parenthesis)
Mass	2.95 lb (1.34 kg) (Touch Screen Controller) 0.99 lb (0.45 kg) (power adapter)
LCD	Type 7 TFT liquid crystal, 800×480, 167,000 colours
Touch Screen	Projection-capacitive type
Communication ports	· RS-485 port ×1 (for connecting four digital I/O interfaces and four watt hour meter interfaces) · LAN port ×1 (for connecting PC)
USB port	USB memory stick connection port ×2
External contact input	8 inputs
External contact output	4 inputs
Included PC software (*1) (Requires a separate PC (*3))	· Remote Control Software · Energy Report Software 2 · Section Configuration Software

*1 You can download the owner's manual and installer for "Section Configuration Software" from inside the controller.
After setting the IP address of the computer (Owner's Manual P.31), use the customer's web browser to access the following URL.
<http://192.168.2.80/touchscreencontroller/EN-UL/download.html> *2

*2 Input the value set in "Set the IP address of the Touch screen controller" (Owner's Manual P.89) in place of "192.168.2.80".

*3 Conditions for PC connection (operating environment)
OS: Windows 10, Windows 11
LAN port: 10BASE-T or 100BASE-TX wired LAN port
Other: mouse/keyboard, printer (if printing is required)

Function list

Key Features		
Control	ON/OFF	
	Mode	
	Set temp.	
	Fan speed	
	Wind direction	
	Lock setting of remote control	
	Ventilation → ON/OFF	
	Ventilation → Mode	
	Ventilation → Fan speed	
	Night operation	
	Filter sign reset	
	Soft Cooling	
	Energy saving ratio [%]	
	Saving operation	
	Forced Thermo OFF	
	Return Back	
	Eco Temperature Shift	
	Set temp. range limit	
	Monitoring	ON/OFF
		Mode
Set temp.		
Fan speed		
Wind direction		
Lock setting of remote control		
Ventilation → ON/OFF		
Ventilation → Mode		
Ventilation → Fan speed		
Soft Cooling		
Energy saving ratio [%]		
Eco Temperature Shift		
Set temp. range limit		
Outdoor temp.		
Power Level		
Return Back		
Power peak cut		
Filter Sign		
Schedule	Setting unit (Per unit)	
	Setting unit: Weekly schedule (per day of the week)	
	Setting unit: Special day schedule (per date)	
	Setting time (00:00 to 23:59)	
	Setting content	ON/OFF
		Mode
		Set temp.
		Local remote controller operation lock/unlock
		Return Back
		Night operation
		Energy saving ratio [%]
		Ventilation operation
	Vent. Mode	
Ventilation fan speed		
Humidification setting		
Maximum number of schedules per day 64		

Key Features			
External input	Inputs	Main unit	8 inputs
		DIO interface	8 inputs x 4 units
	Functions	Power pulse measurement	
		Demand Interlocking	
		Locking Interlocking	
		Stop Interlocking	
		Operation Interlocking	
For external device ON/OFF indication			
For external device check code display			
External output	Outputs	Main unit	4 outputs
		DIO interface	4 outputs x 4 units
	Functions	Air conditioner check code output	
		Operation output	
		System Controller check code output	
		Operation output to external device	

Table of differences in functions of BMS-CT2560U-UL

Settings screen	Function	BMS-CT2560U-E/TR		
		Prior to ver. 10.3.0.0	Ver. 10.3.0.0 and later	Ver. 10.3.4.0 and later
Option	Stirring operation	-	○	○
	Night operation setting	○	-	-
	Night operation setting (VRF, LC, ESTIA)	-	○	○
	Night operation setting (RAC)	-	○	○
	Auto mode	-	○	○
	Anti bacteria	-	○	○
	Night set back	-	○	○
	Hot water boost	-	○	○
	Frost protection	-	○	○
	HiPower	-	○	○
	ECO	-	○	○
	Quiet FCU	-	○	○
	Power Select	-	○	○
	PURE	-	○	○
	Fireplace	-	○	○
	Unit information	-	○	○
	ESTIA information	-	○	○
Humidification setting	-	-	○	
Excessive CO2 setting	-	-	○	
Service settings	Outdoor DN	-	○	○

Table of different models compatible with BMS-CT2560U-UL

Target device	BMS-CT2560U-UL	
	Prior to ver. 10.3.0.0	Ver. 10.3.0.0 and later
Multi air conditioners for buildings (Ceiling cassette, ceiling embedded, ceiling hanging, air to air heat exchanger with coil, etc.)	○	○
Light Commercial	○	○
Package air conditioners for facilities	○	○
Hot Water Module (* For use outside Japan only)	○	○
DX-Coil Interface TA type (* For use outside Japan only)	○	○
DX-Coil Interface TF type (* For use outside Japan only)	-	○
Air to Water Heat Pump (ATW) (* For use outside Japan only)	-	○
Room Air Conditioner (home) (RAC TU2C-LINK I/F connection * For use outside Japan only)	-	○
Room Air Conditioner (home) (ON-OFF control interface connection * For use inside Japan only)	-	○
Air to Air Heat Exchanger	○	○
General purpose device control interface	○	○
DX-Coil Interface DDC type (* For use outside Japan only)	○	○
External device (DI/DO) (Lighting, ventilation fan, etc.)	○	○

1-2. Basic Usage

This section explains the basic setting method for operation Start/Stop and air conditioning, the setting method for the operation schedule, and the confirmation method for the overall air conditioning system.

Start/Stop Operation

Overall air conditioning system operation method

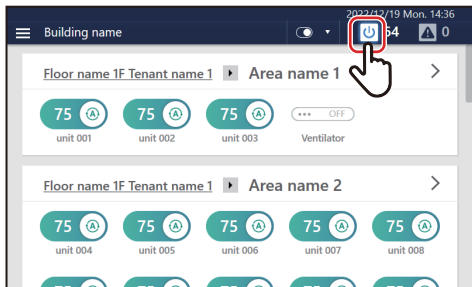

1 Tap  

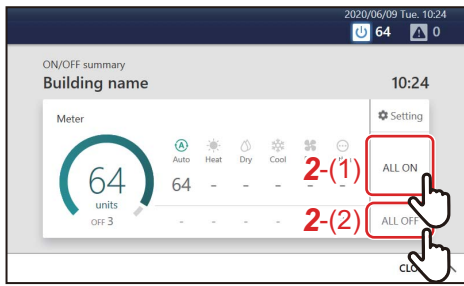

2 Tap [2-(1)] or [2-(2)]

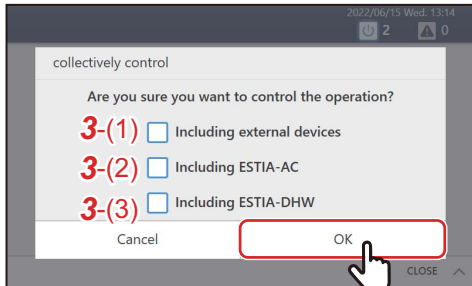

3 Select the equipment to add to be operated, and then tap [3-(4)]

All the air conditioners and the selected equipment start or stop operations.

The selected equipment and air conditioners are added to equipment to be operated. *

No.	Item	Equipment to be added
3-(1)	Including external devices	External device
3-(2)	Including ESTIA-AC	Air to Water Heat Pump (ATW) with air conditioning function
3-(3)	Including ESTIA-DHW	Air to Water Heat Pump (ATW) in hot water supply function

* About selecting confirmation popups

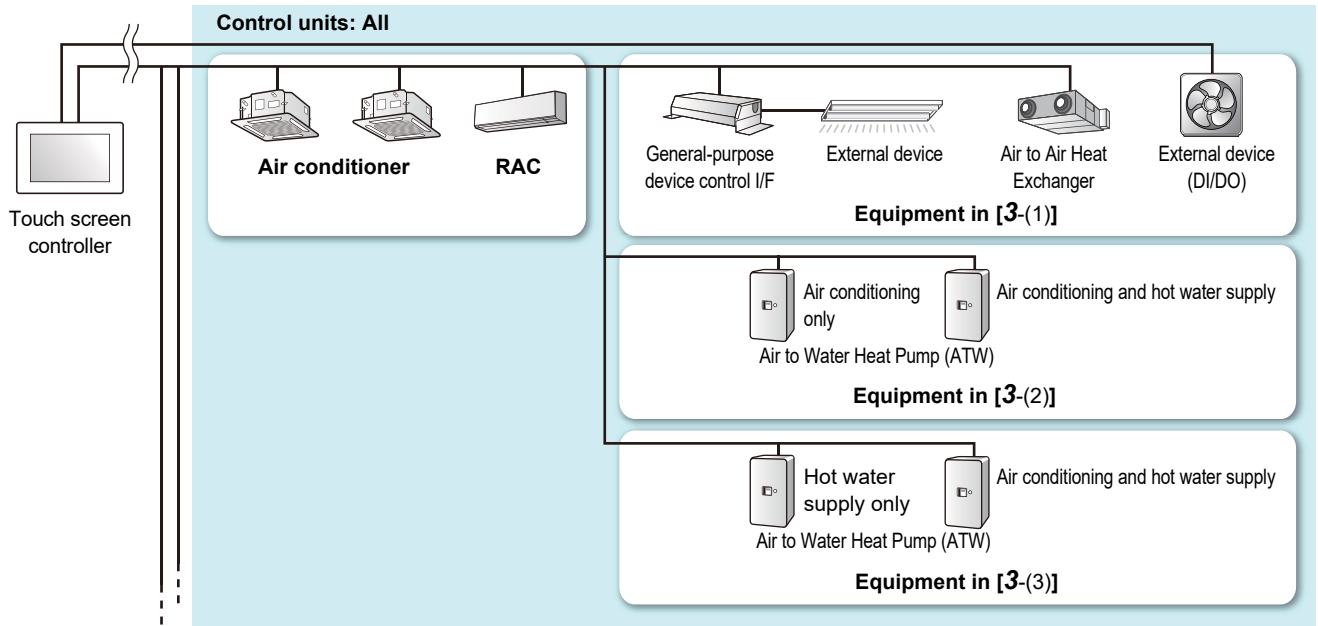

Group unit operation method

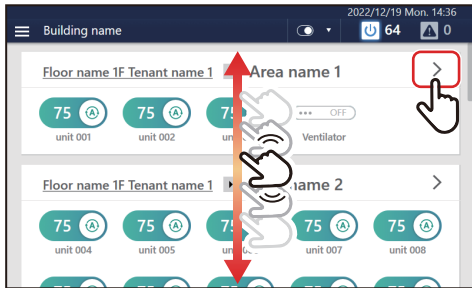

- 1 Scroll the home screen to display the group you want to change the settings for, then tap >

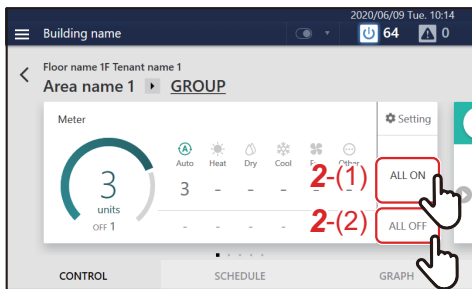

- 2 Tap [2-(1)] or [2-(2)]

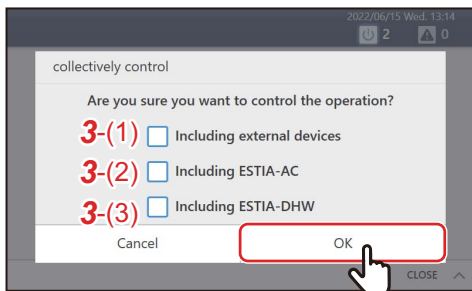

- 3 Select the equipment to add to be operated, and then tap [3-(4)]

All the air conditioners selected in the group and the selected equipment start or stop operations.

The selected equipment and air conditioners are added to equipment to be operated. *

No.	Item	Equipment to be added
3-(1)	Including external devices	External device
3-(2)	Including ESTIA-AC	Air to Water Heat Pump (ATW) with air conditioning function
3-(3)	Including ESTIA-DHW	Air to Water Heat Pump (ATW) in hot water supply function

* About selecting confirmation popups

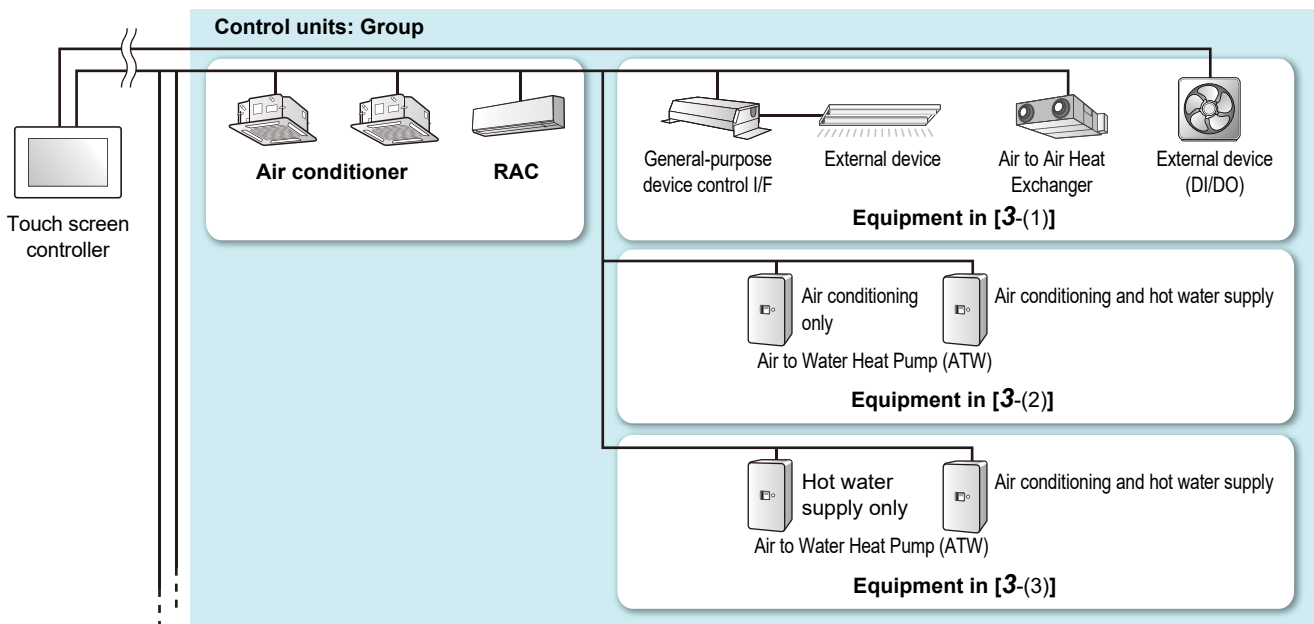

Operation method in units of air conditioner or ON/OFF unit

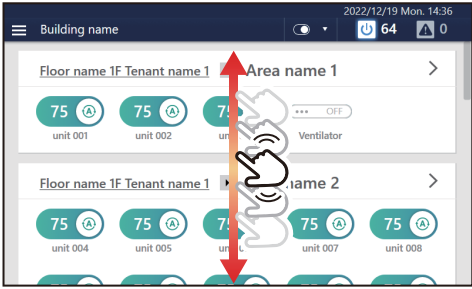

1 Scroll the home screen and display the air conditioner or ON/OFF unit that you want to change the settings for

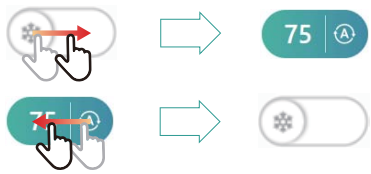

2 Drag or flick the  of the corresponding switch
 Drag or flick to the right to start operation.
 Drag or flick to the left to stop operation.

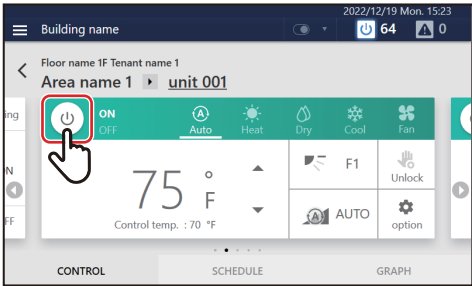

NOTE
 You can also start/stop operation by tapping the power icon on the [CONTROL] tab on the individual control screen displayed by tapping the switch.

Change the Air Conditioning Settings

Group unit operation method

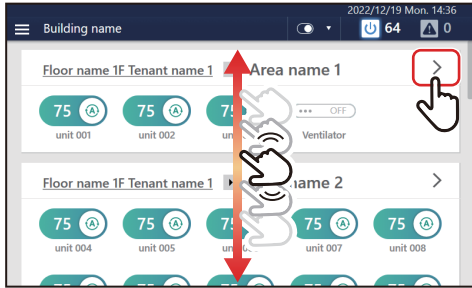

1 Scroll the home screen to display the group you want to change the settings for, then tap **>**

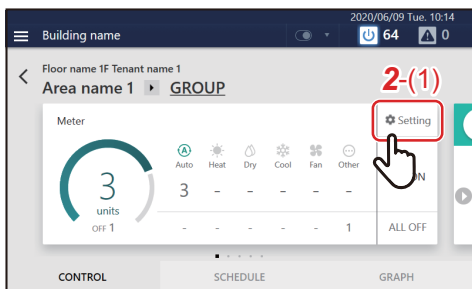

2 Tap **[2-(1)]**
The batch settings screen is displayed.

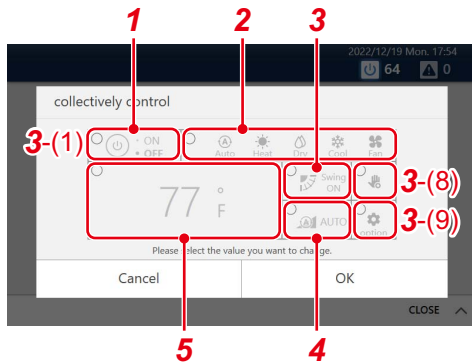

3 Change settings

Example: When changing the operation status settings

3-1 Tap **[3-(1)]**
The operation status settings screen is displayed.

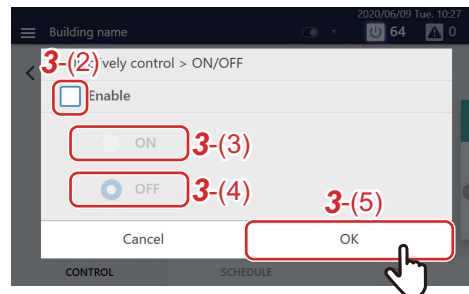



3-2 Set the check box of **[3-(2)]** to
You can now change the settings.

3-3 Select **[3-(3)]** or **[3-(4)]** and tap **[3-(5)]**
Return to the batch settings screen.

3-4 Change the other items with reference to steps **3-1** to **3-3**
For the setting details, see the following table.

No.	Name	Functions
1	ON/OFF	Can be set to [ON/OFF].
2	Mode	Can be set to [Auto/Heat/Dry/Cool/Fan]. <div style="background-color: #cccccc; padding: 2px;">NOTE</div> <ul style="list-style-type: none"> A bar is displayed at the bottom of the icon for the currently selected mode. Operation modes that cannot be set are not displayed.

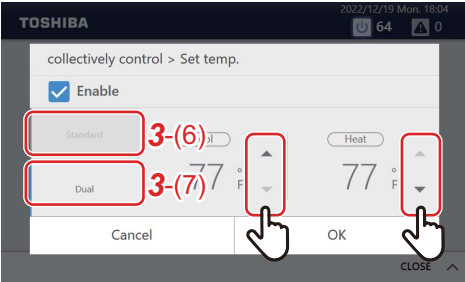
No.	Name	Functions
3	Wind direction	<p>Tap ◀ ▶ to switch to the following.</p>  <p>• NOTE</p> <p>Depending on the connected model, it may not be configurable.</p>
4	Fan Speed	<p>Tap ◀ ▶ to switch to the following.</p>  <p>• NOTE</p> <p>Depending on the connected model, it may not be configurable.</p>
5	Set temp.	<p>Tap ▲ ▼ to change the set temperature.</p> <p>• NOTE</p> <ul style="list-style-type: none"> When set to a temperature outside the setting range limit of each operation mode, the temperature is changed to the upper or lower limit of the setting range. If there are Dual Set Point compatible models in the group, two tabs will be displayed. When you tap [3-(6)], one set temperature is displayed, and when you tap [3-(7)], two set temperatures are displayed. Tap ▲ ▼ to change the set temperature. 

• **NOTE**

- For models that do not have the function set, the setting change is ignored.
- For the setting of [Lock] [Unlock] of [3-(8)], see "Local Remote Controller Lock" (Owner's Manual P.51).
- For the [Option] settings of [3-(9)], see "Set Operation Details" (Owner's Manual P.53).

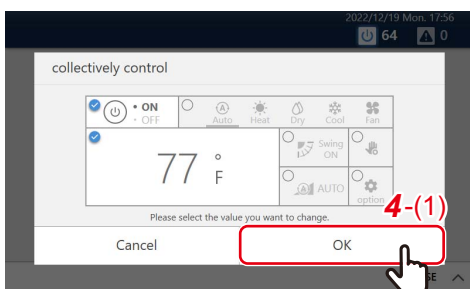

4 Confirm that the changed item is checked, and tap [4-(1)]

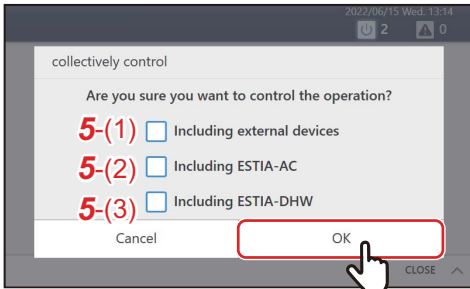

5 Select the equipment to add to be operated, and then tap [5-(4)]

All the air conditioners selected in the group and the selected equipment start or stop operations.

The selected equipment and air conditioners are added to equipment to be operated. *

No.	Item	Equipment to be added
5-(1)	Including external devices	External device
5-(2)	Including ESTIA-AC	Air to Water Heat Pump (ATW) with air conditioning function
5-(3)	Including ESTIA-DHW	Air to Water Heat Pump (ATW) in hot water supply function

* About selecting confirmation popups

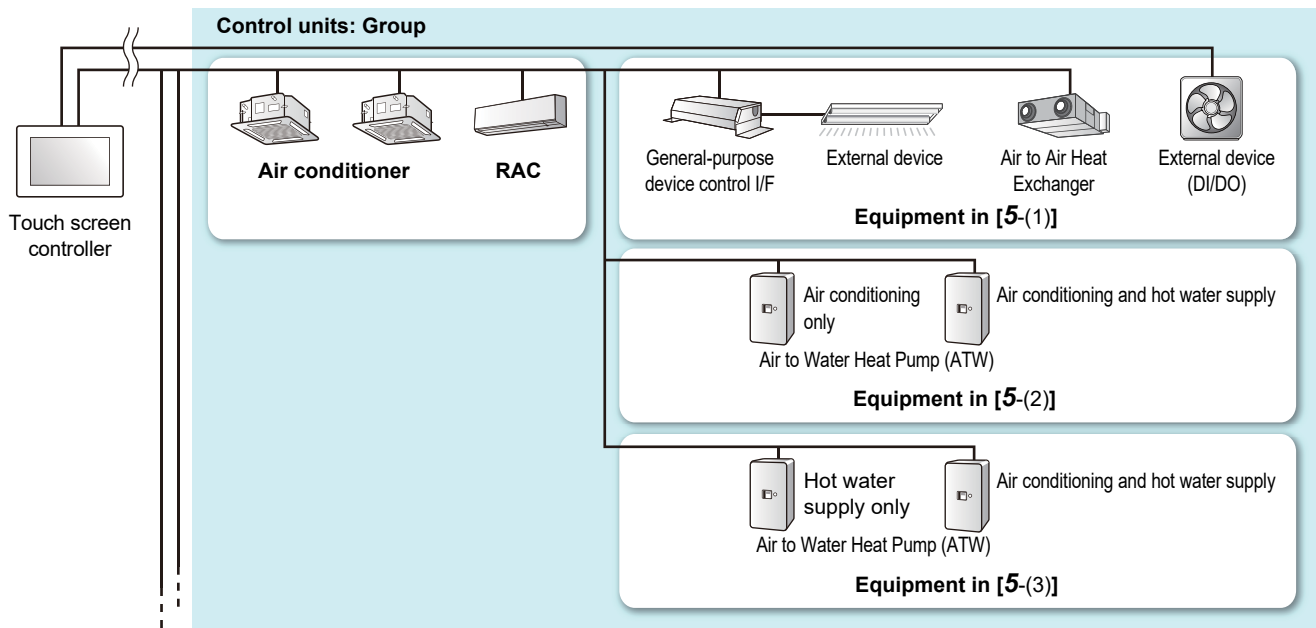

Air conditioner unit operation method

NOTE

To change the settings, it is necessary to set to the operation status. (P.11)

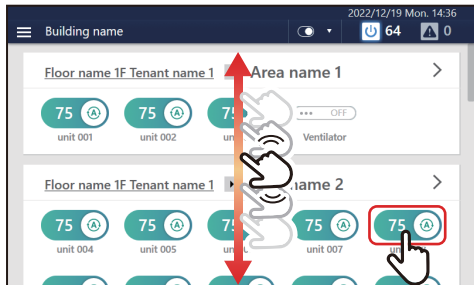

1 Scroll the home screen, display the air conditioner you want to change the settings for, then tap the switch

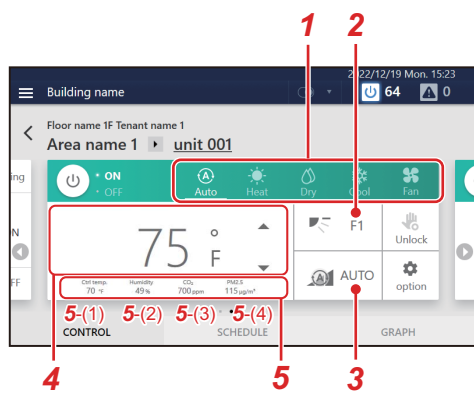

2 Change settings

No.	Name	Functions						
1	Mode	<p>Can be set to [Auto/Heat/Dry/Cool/Fan].</p> <p>NOTE</p> <ul style="list-style-type: none"> A bar is displayed at the bottom of the icon for the currently selected mode. Operation modes that cannot be set are not displayed. 						
2	Wind direction	<p>Tap to switch to the following.</p> <div style="display: flex; justify-content: space-around; align-items: center;">  </div> <table border="1" style="width: 100%; border-collapse: collapse;"> <thead> <tr> <th style="width: 50%;">Operation Mode</th> <th style="width: 50%;">Setting Range</th> </tr> </thead> <tbody> <tr> <td>Auto (Cool)/Cool/Dry</td> <td>Swing ON→Swing OFF→F1→F2→F3→Swing ON (Return to the beginning)</td> </tr> <tr> <td>Auto (Heat)/Heat/Fan</td> <td>Swing ON→Swing OFF→F1→F2→F3→F4→F5→Swing ON (Return to the beginning)</td> </tr> </tbody> </table> <p>NOTE</p> <p>Depending on the connected model, it may not be configurable.</p>	Operation Mode	Setting Range	Auto (Cool)/Cool/Dry	Swing ON→Swing OFF→F1→F2→F3→Swing ON (Return to the beginning)	Auto (Heat)/Heat/Fan	Swing ON→Swing OFF→F1→F2→F3→F4→F5→Swing ON (Return to the beginning)
Operation Mode	Setting Range							
Auto (Cool)/Cool/Dry	Swing ON→Swing OFF→F1→F2→F3→Swing ON (Return to the beginning)							
Auto (Heat)/Heat/Fan	Swing ON→Swing OFF→F1→F2→F3→F4→F5→Swing ON (Return to the beginning)							

No.	Name	Functions															
3	Fan Speed	<p>Tap to switch to the following.</p>  <p>• NOTE</p> <p>Depending on the connected model, it may not be configurable.</p>															
4	Set temp.	<p>Tap ▲ ▼ to change the set temperature.</p> <p>• NOTE</p> <ul style="list-style-type: none"> • If the operation mode is FAN, the temperature cannot be set. • [4-(1)] shows the indoor temperature detected by the indoor unit after partial compensation. *Depending on conditions such as the installation site of the indoor unit, it may differ from actual room temperature. • In this area, icons and text are displayed, such as for frost protection, preparing for operation, or preparing for heating operation. 															
5	Sensor value display	<table border="1"> <thead> <tr> <th>No.</th> <th>Name</th> <th>Functions</th> </tr> </thead> <tbody> <tr> <td>5-(1)</td> <td>Ctrl temp.</td> <td> <p>Indicates the partially compensated temperature inside the room that is detected by the indoor unit.</p> <p>• NOTE</p> <p>The room temperature may differ from the actual temperature depending on the installation location of the indoor unit and other conditions.</p> </td> </tr> <tr> <td>5-(2)</td> <td>Humidity</td> <td>Indicates the humidity detected by the indoor unit.</td> </tr> <tr> <td>5-(3)</td> <td>CO₂</td> <td>Indicates the CO₂ detected by the indoor unit.</td> </tr> <tr> <td>5-(4)</td> <td>PM2.5</td> <td>Indicates PM2.5 detected by the indoor unit.</td> </tr> </tbody> </table> <p>• NOTE</p> <p>Depending on the connected model, it may not be indicated.</p>	No.	Name	Functions	5-(1)	Ctrl temp.	<p>Indicates the partially compensated temperature inside the room that is detected by the indoor unit.</p> <p>• NOTE</p> <p>The room temperature may differ from the actual temperature depending on the installation location of the indoor unit and other conditions.</p>	5-(2)	Humidity	Indicates the humidity detected by the indoor unit.	5-(3)	CO ₂	Indicates the CO ₂ detected by the indoor unit.	5-(4)	PM2.5	Indicates PM2.5 detected by the indoor unit.
No.	Name	Functions															
5-(1)	Ctrl temp.	<p>Indicates the partially compensated temperature inside the room that is detected by the indoor unit.</p> <p>• NOTE</p> <p>The room temperature may differ from the actual temperature depending on the installation location of the indoor unit and other conditions.</p>															
5-(2)	Humidity	Indicates the humidity detected by the indoor unit.															
5-(3)	CO ₂	Indicates the CO ₂ detected by the indoor unit.															
5-(4)	PM2.5	Indicates PM2.5 detected by the indoor unit.															

• **NOTE**

- For the setting of [(1)], see "Local Remote Controller Lock" (Owner's Manual P.51).
- For the setting of [(2)], see "Set Operation Details" (Owner's Manual P.53).
- If there is no corresponding function, that item is not displayed.

Example of a model without a flap

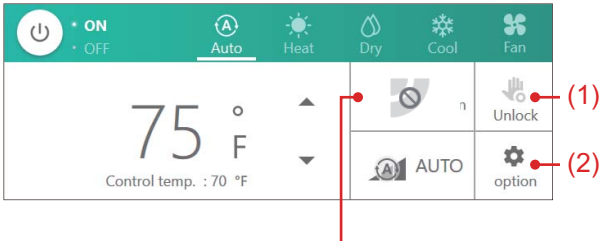

Since you cannot set the air direction, it does not change even if you tap it.

Example of a model where only a certain fan speed can be set

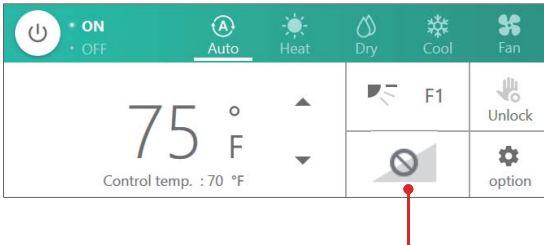

Since you cannot change the fan speed, it does not change even if you tap it.

Example of a case in which the wind direction cannot be changed

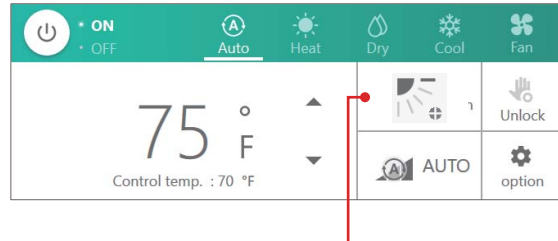

Because the flap is locked, you cannot change the wind direction even if you tap it.

1-3. Scheduled functions

Set the Operation Schedule

You can configure the air conditioners or the ON/OFF unit with a “Weekly schedule”, through which settings such as operation start/stop are changed depending on the specified time for any day from Sunday to Saturday, or a “Special day schedule”, through which settings are changed for special days such as national holidays or special holidays. The operation schedule is set on the [SCHEDULE] tab of the group screen or individual control screen.

NOTE

If a day is set in both the Weekly schedule and the Special day schedule, the Special day schedule applies and the Weekly schedule is disabled for that day.

Screen description

This section explains how to view the [SCHEDULE] tab when setting the operation schedule.

NOTE

Refer to the description of the [CONTROL] tab for the display items that are not explained. (Owner's Manual P.22, 24)

Group screen

The schedule set for the air conditioners or ON/OFF unit in the group is displayed in list format in time units.

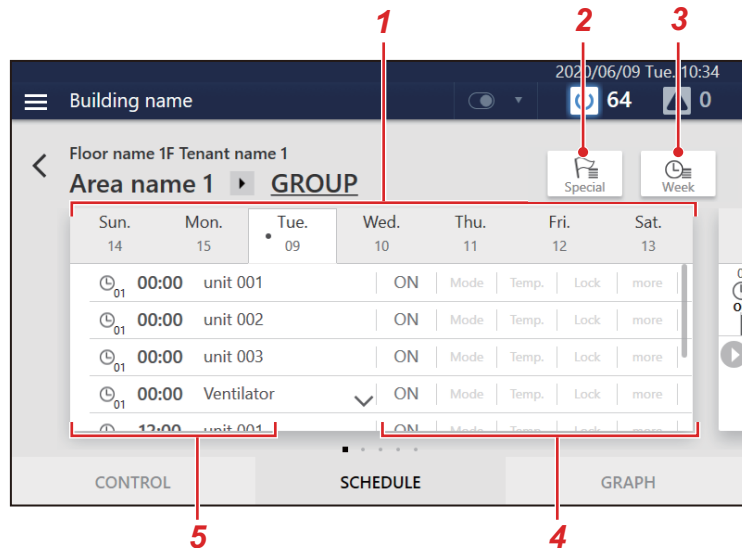

No.	Functions
1	You can switch the display in day-of-week units.
2	Displays the setting screen of Special day schedule.
3	Displays the setting screen of Weekly schedule.
4	The schedule settings content (ON/OFF, Mode, Temp., Lock, more) is displayed.
5	The times when the schedule is executed and the air conditioners and ON/OFF unit for which the schedule is executed are displayed.

Individual control screen

The schedule set for the air conditioner or ON/OFF unit being displayed is displayed on a 24-hour time scale.

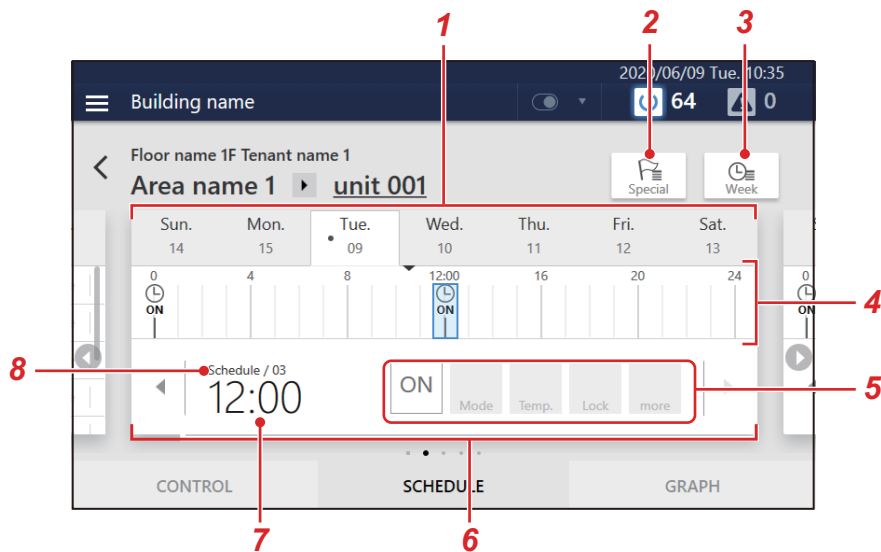

No.	Functions
1	You can switch the display in day-of-week units.
2	Displays the setting screen of Special day schedule.
3	Displays the setting screen of Weekly schedule.
4	🕒 is displayed at the times when the schedule is set. When operation start/stop is set, [ON] or [OFF] is displayed below 🕒. When setting change is set, ⚙️ is displayed below 🕒. Also, the currently displayed schedule is displayed in blue.
5	The schedule settings content (ON/OFF, Mode, Temp., Lock, more) is displayed.
6	You can switch the display to the previous or next schedule.
7	The times when the schedule will be executed are displayed.
8	The schedule setting number is displayed.

Create a new weekly schedule

In a Weekly schedule, you can set:

- Start time
- Day(s) of the week
- Air conditioner(s) or ON/OFF unit
- ON/OFF

Schedule settings can be applied from either the group screen or the individual control screen. In the following procedure, the individual control screen is used to explain.

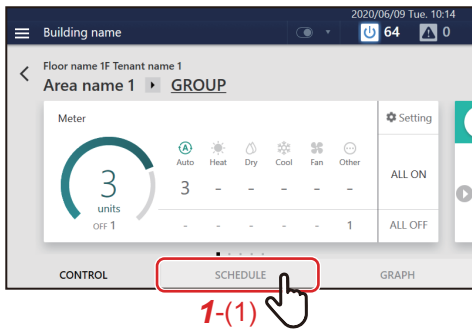

1 Tap [1-(1)] on the group screen or individual control screen

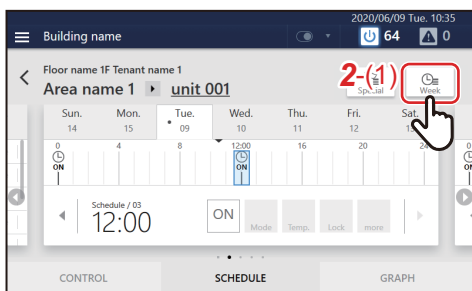

2 Tap [2-(1)]

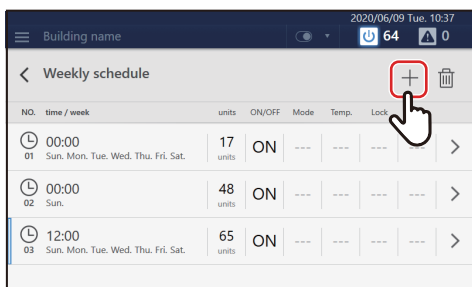

3 Tap +

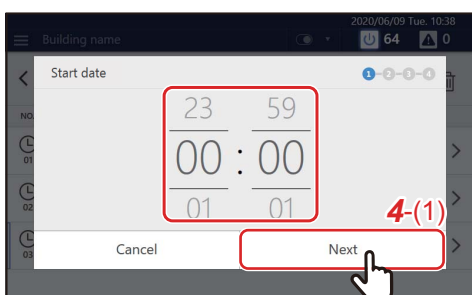

4 Tap or flick to set the start time and tap [4-(1)]

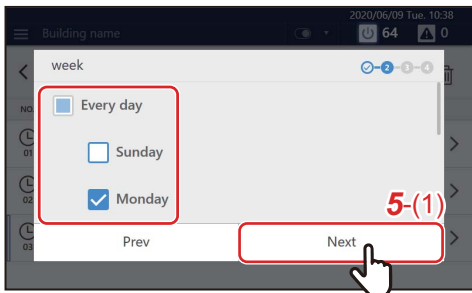

5 Select the day of the week to execute and tap [5-(1)]

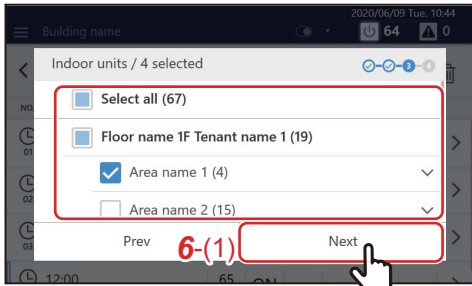

6 Select the air conditioner(s) or ON/OFF unit for setting the schedule and tap [6-(1)]

You cannot select a model that has already been scheduled at the same time.



7 Tap the check box of [7-(1)] and set it to , then select [7-(2)] or [7-(3)] and tap [7-(4)]

You can only set [ON/OFF] here.

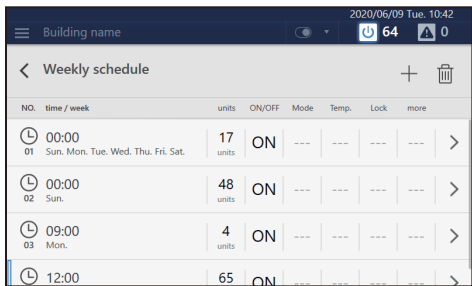

A schedule has been registered.

NOTE

- When setting details such as operation mode or set temperature, etc. as a schedule, refer to "Change the Operating Schedule" (P.24).
- When deleting a registered schedule, refer to "Delete the operation schedule" (P.31).

Create a new special day schedule

In a Special day schedule, you can register special days, such as national holidays and special holidays, to configure a special day schedule that differs from the Weekly schedule.

Schedules can be configured from the group screen or the individual control screen. The following procedure is explained using the individual control screen.

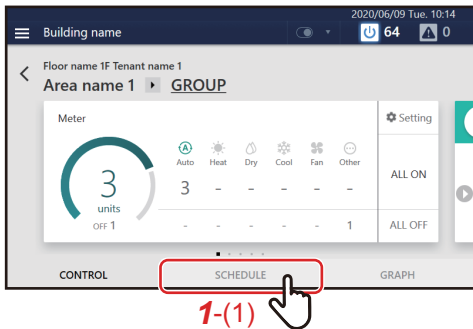

1 Tap [1-(1)] on the group screen or the individual control screen

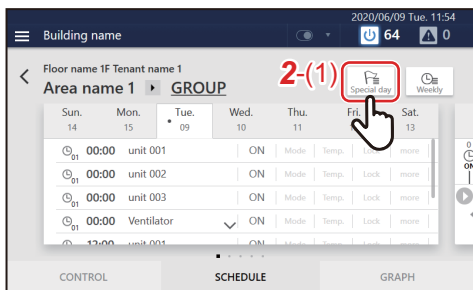

2 Tap [2-(1)]

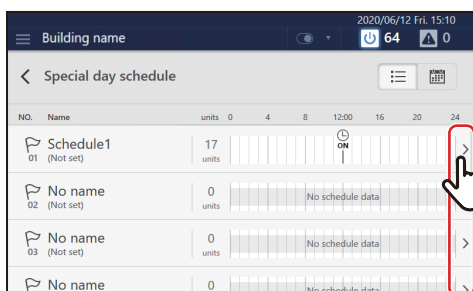

3 Tap >

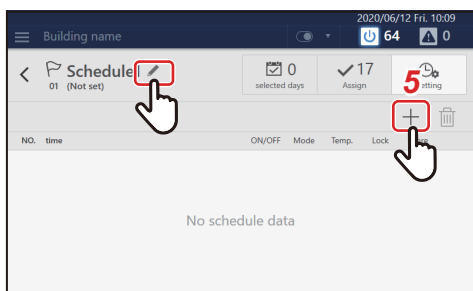

4 Tap  and set the schedule name

A keyboard is displayed. Enter the name and then tap [4-(1)].

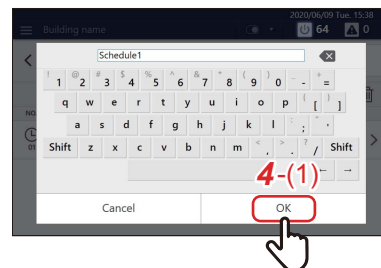

5 Tap + to go to step 6

NOTE

- Tap [Shift] to toggle between upper case letters and lower case letters, and numbers and symbols.
- Tap  to delete one character.

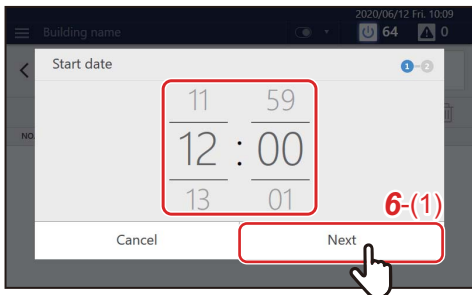

6 Tap or flick to set the start date, and then tap [6-(1)]



7 Tap the check box of [7-(1)] and set it to , then select [7-(2)] or [7-(3)] and tap [7-(4)]
You can only set [ON/OFF] here.

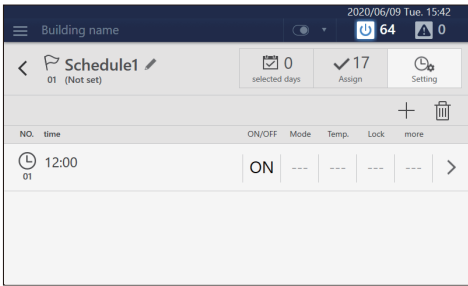

The schedule is registered.

NOTE

- When setting details such as the mode or the set temperature to a schedule, refer to "Change the details of the special day schedule" (P.26)
- When deleting a registered schedule, refer to "Delete the operation schedule" (P.31).

Change the Operating Schedule

The operating schedule settings can be changed from the [Menu] button, the group screen, or the individual control screen. There are two types of operating schedules: Weekly schedule and Special day schedule. The following procedure is explained using the individual control screen.

NOTE

If a day is set in both the Weekly schedule and the Special day schedule, the Special day schedule applies and the Weekly schedule is disabled for that day.

Change the details of the weekly schedule

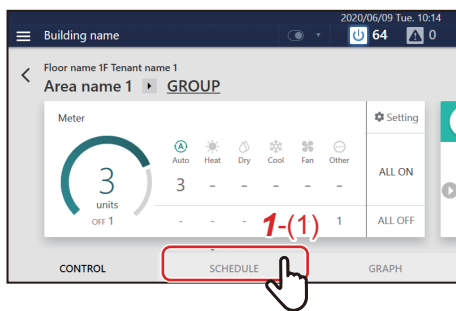

1 Tap [1-(1)] on the group screen or the individual control screen

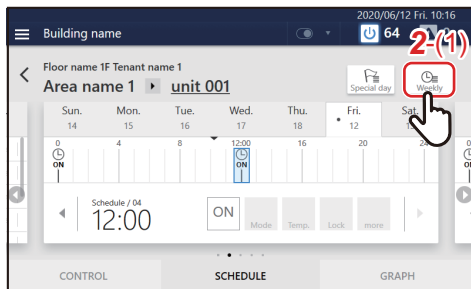

2 Tap [2-(1)]

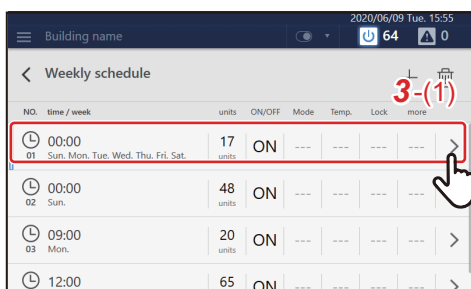

3 Tap [3-(1)] of the schedule you want to modify

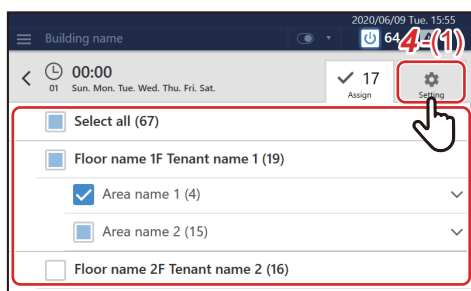

4 Modify the target air conditioner(s) or ON/OFF unit, then tap [4-(1)]

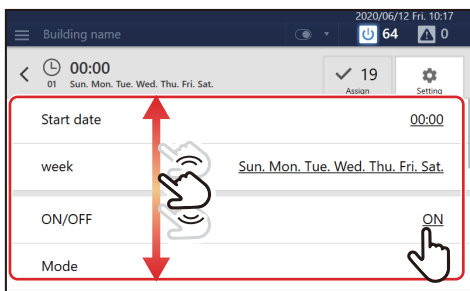

- 5** Scroll the screen and tap the value of the item you want to set. After changing the setting, tap [OK]
See "Setting items list" (P.28) for the items that can be configured.

Change the details of the special day schedule

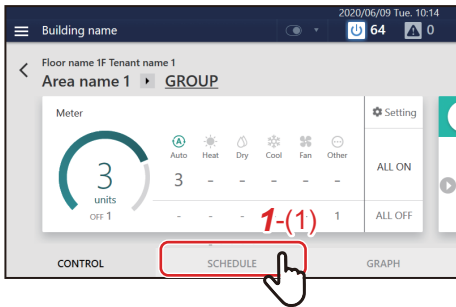

1 Tap [1-(1)] on the group screen or the individual control screen

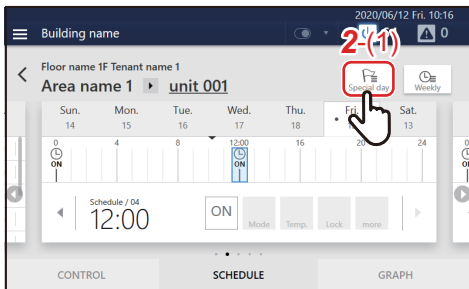

2 Tap [2-(1)]

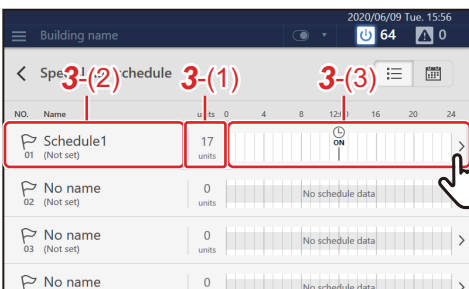

3 Tap [3-(1)] of the schedule you want to modify

- [3-(1)] Unit setting: Go to step 4
- [3-(2)] Special day setting: Go to step 5
- [3-(3)] Operating schedule setting: Go to step 6

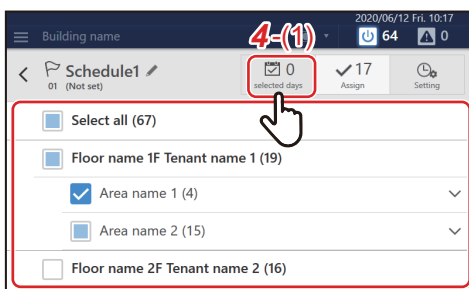

4 Modify the target air conditioner(s) or ON/OFF unit, then tap [4-(1)]

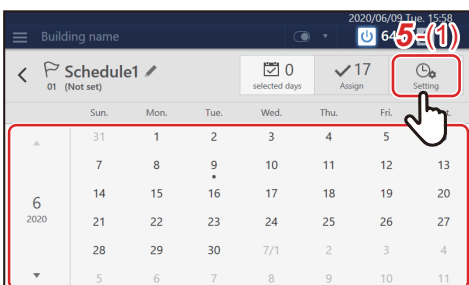

5 Tap the date you want to configure, modify the settings, and then tap [5-(1)]

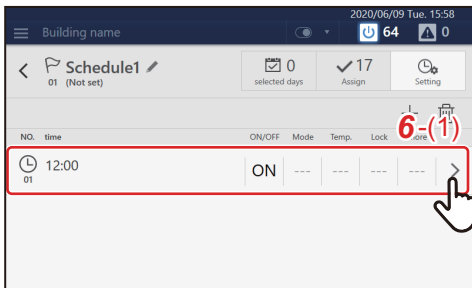

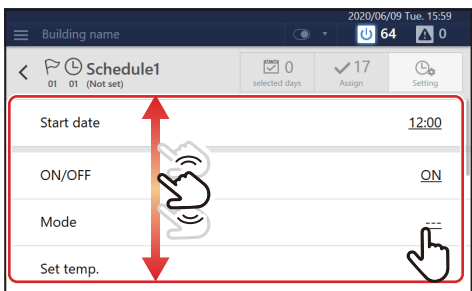

6 Tap [6-(1)] of the time you want to modify

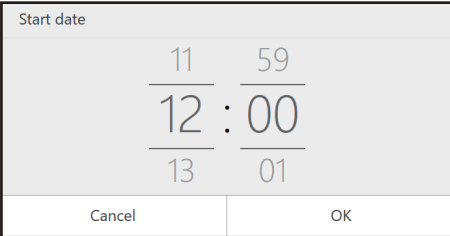
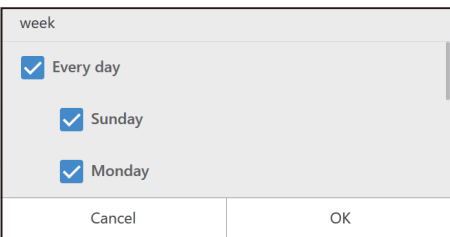
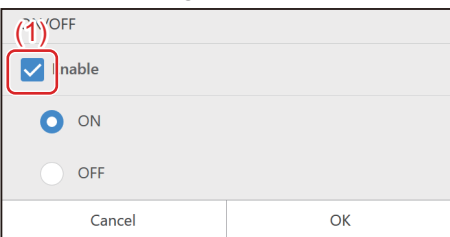
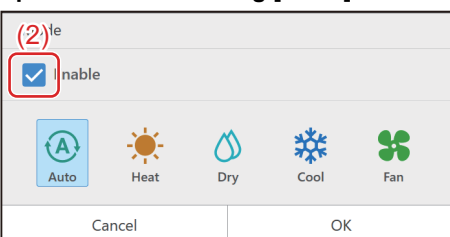
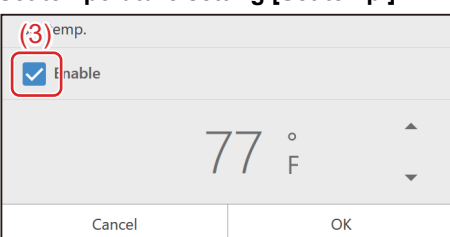
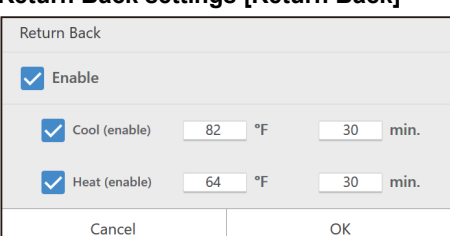

7 Scroll the screen and tap the value of the item you want to set. After changing the setting, tap [OK]
See "Setting items list" (P.28) for the items that can be configured.

Setting items list

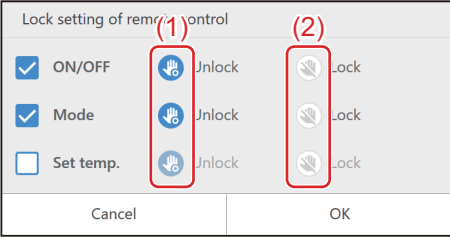
Setting Items	Setting Procedure
<p>Time setting [Start date]</p> 	<p>Tap or flick to change the time.</p>
<p>Day of the week setting [week]</p> 	<p>Set the check box(es) of the day(s) of the week on which you want to execute the schedule to <input checked="" type="checkbox"/>.</p> <p>NOTE</p> <p>The day of the [week] setting is not displayed in Special day schedule.</p>
<p>Operation setting [ON/OFF]</p> 	<p>To enable the setting, set the check box of [(1)] to <input checked="" type="checkbox"/> and select a value.</p> <p>NOTE</p> <p>Hot water supply function of the ATW cannot be set to [ON, OFF] by this setting.</p>
<p>Operation mode setting [Mode]</p> 	<p>To enable the setting, set the check box of [(2)] to <input checked="" type="checkbox"/> and select a value.</p>
<p>Set temperature setting [Set temp.]</p> 	<p>To enable the setting, set the check box of [(3)] to <input checked="" type="checkbox"/>, tap ▲ ▼, then change the set temperature.</p>
<p>Return Back settings [Return Back]</p> 	<p>An energy saving function whereby if you temporarily change the set temperature to one which increases the load, you can automatically return to the energy saving set temperature after a certain time has elapsed. For example, if you set COOL to 82°F (28°C)/30 minutes, then if the set temperature is set to below 82°F (28°C), the Unit will return to 82°F (28°C) 30 minutes after the change.</p> <p>NOTE</p> <p>Displayed in the case of a compatible air conditioner.</p>

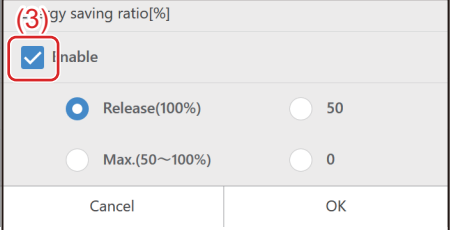
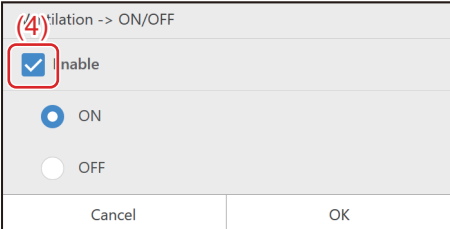
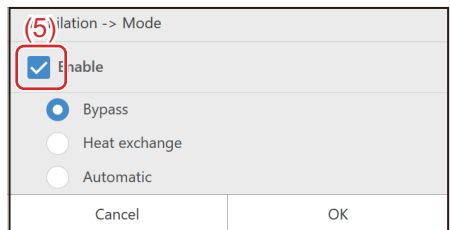
Setting Items	Setting Procedure
<p>Local operation prohibition setting [Lock setting of remote control]</p> 	<p>Tap the check box of the function whose setting you want to change to set it to <input checked="" type="checkbox"/>, then select [(1)] or [(2)].</p>
<p>Night operation setting [Night operation]</p> 	<p>You can change the [ON/OFF] of the night operation of the target device.</p>
<p>Save operation setting [Energy saving ratio[%]]</p> 	<p>To enable the setting, set the check box of [(3)] to <input checked="" type="checkbox"/>. For details, see "Control air conditioner power" (Owner's Manual P.58).</p>
<p>Ventilation operation setting [Ventilation → ON/OFF]</p> 	<p>You can turn ON/OFF the operation of the ventilator connected to the air to air heat exchanger(s) or air conditioner(s). To enable the setting, set the check box of [(4)] to <input checked="" type="checkbox"/> and apply the setting.</p>
<p>Vent. Mode [Ventilation → Mode]</p> 	<p>You can set the ventilation mode of the ventilator connected to the air to air heat exchanger(s) or the air conditioner(s). To enable the setting, set the check box of [(5)] to <input checked="" type="checkbox"/> and apply the setting. For details, see "Set ventilation mode" (Owner's Manual P.56).</p>

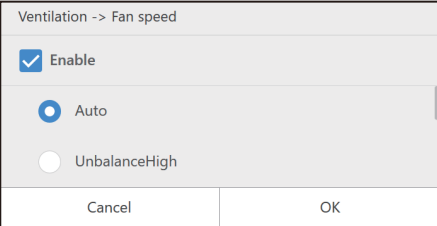
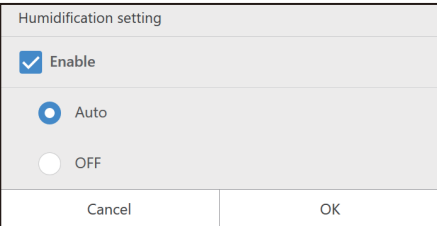
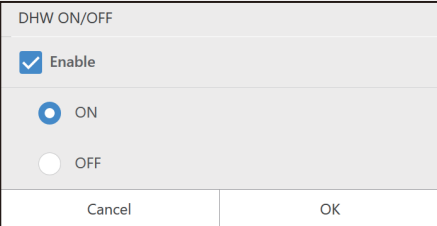
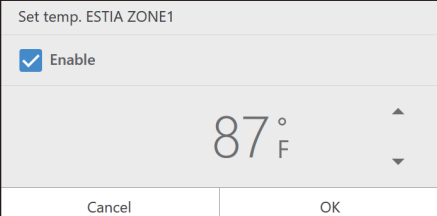
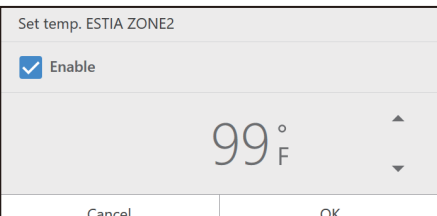
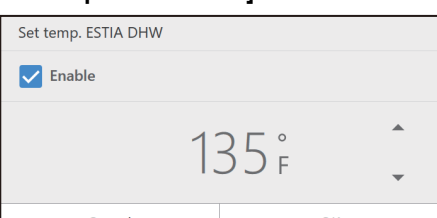
Setting Items	Setting Procedure
<p>Ventilation → Fan speed</p> 	<p>You can set the ventilation fan speed of the ventilator connected to the air to air heat exchange unit or the air conditioner.</p> <p>* Details for unbalance settings vary depending on the settings of the connected model. To enable the setting, set the check box of [Enable] to <input checked="" type="checkbox"/> and apply the setting. For details, see "Setting the ventilation fan speed" (P.56).</p>
<p>Humidification setting</p> 	<p>The humidification setting of the air conditioning can be set. To enable this setting, select <input checked="" type="checkbox"/> for the [Enable] checkbox, and then select [Auto/OFF].</p>
<p>DHW ON/OFF [DHW ON/OFF]</p> 	<p>This setting item is specifically for the Air to Water Heat Pump (ATW) in the hot water supply function.</p> <p>To enable this setting, select <input checked="" type="checkbox"/> for the [Enable] check box, and then select [ON, OFF].</p> <p>NOTE</p> <p>Indoor units, ON/OFF units, and the air conditioning function of the ATW cannot be set to [ON, OFF] by this setting.</p>
<p>ZONE1 Set temp. [Set temp. ESTIA ZONE1]</p> 	<p>This setting item is specifically for the Air to Water Heat Pump (ATW) in the air conditioning function.</p> <p>To enable this setting, select <input checked="" type="checkbox"/> for the [Enable] check box, and then tap ▲ ▼ to change the set temperature.</p> <p>The set temperature cannot be changed in increments of 0.5°C.</p>
<p>ZONE2 Set temp. [Set temp. ESTIA ZONE2]</p> 	<p>This setting item is specifically for the Air to Water Heat Pump (ATW) in the air conditioning function.</p> <p>To enable this setting, select <input checked="" type="checkbox"/> for the [Enable] check box, and then tap ▲ ▼ to change the set temperature.</p> <p>The set temperature cannot be changed in increments of 0.5°C.</p>
<p>Hot water setting temperature [Set temp. ESTIA DHW]</p> 	<p>This setting item is specifically for the Air to Water Heat Pump (ATW) in the hot water supply function.</p> <p>To enable this setting, select <input checked="" type="checkbox"/> for the [Enable] check box, and then tap ▲ ▼ to change the set temperature.</p> <p>The set temperature cannot be changed in increments of 0.5°C.</p>

Delete the operation schedule

You can delete the schedule from either the group screen or the individual control screen. In the following procedure, the individual control screen is used.

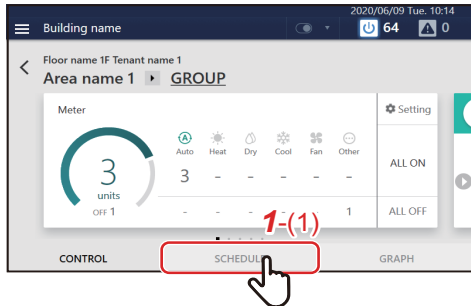

1 Tap [1-(1)] on the group screen or individual control screen

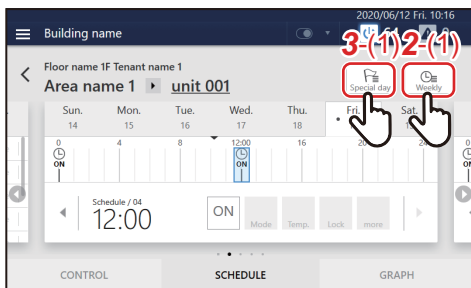

2 Tap [2-(1)] to go to step 4

3 (In case of Special day setting) tap [3-(1)]
Tap [3-(2)] of the schedule you want to modify to go to step 4.

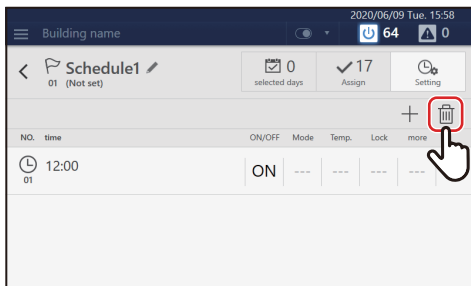
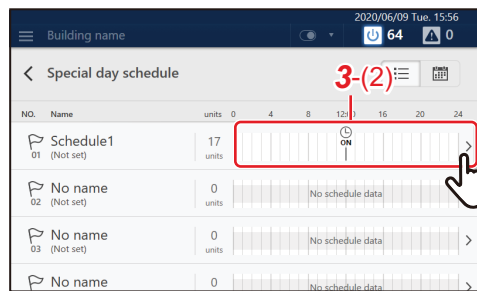

4 Tap 

(Some displayed items differ between the Weekly schedule screen and the Special day schedule screen, but the procedure shown below is the same.)

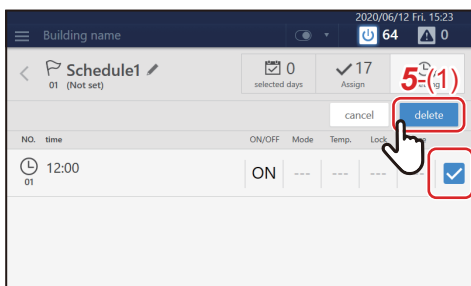

5 Set the check box of the schedule you want to delete to then tap [5-(1)]

1-4. External I/O

Number of points

The external input has the following number of input points.

Equipment	Input/Output	Number of points
Main unit	External input	8 points
	External output	4 points
DIO I/F 1	External input	8 points
	External output	4 points
DIO I/F 2	External input	8 points
	External output	4 points
DIO I/F 3	External input	8 points
	External output	4 points
DIO I/F 4	External input	8 points
	External output	4 points

* It is necessary to implement crossover wiring with RS-485 for DIO I/F and the main unit.

Functions

The following functions can be set for the main unit and DIO I/F 1 to 4, respectively.

Input/Output	I / O Function	Functions	Settings	
Input	Electric power	Count the power pulses. Measure a pulse waveform of 50 msec or more as one pulse.	• Pulse constant (kWh/pulse)	
	Control	Stop	When ON, stops the specified air conditioner.	• a contact (ON at signal input, OFF at release)/ b contact (OFF at signal input, ON at release)
		Run	When ON, runs the specified air conditioner.	• a contact (ON at signal input, OFF at release)/ b contact (OFF at signal input, ON at release)
		Lock	When ON, controls the specified air conditioner to the specified setting contents.	• a contact (ON at signal input, OFF at release)/ b contact (OFF at signal input, ON at release) • Pattern 0 (Stop at ON, do nothing at OFF)/ Pattern 1 (Stop at ON, "Run/Stop" at OFF switch prohibit release)/ Pattern 2 (Stop at ON + "Run/Stop" switching prohibited, "Run/Stop" at OFF switching prohibited release)/ Pattern 3 (Stop/Run)
		Demand	At ON, perform demand control on the specified air conditioner.	• a contact (ON at signal input, OFF at release)/ b contact (OFF at signal input, ON at release) • Indoor unit (Stop/Save maximum/Save 50%/Thermo OFF (no delay release)/Thermo OFF (10 seconds delay)/Thermo OFF (20 seconds delay)/Thermo OFF (30 seconds delay)/Thermo OFF (60 seconds delay)/FAN/ Stop + local remote control operation prohibited/ FAN + local remote control mode change prohibited) • Outdoor unit (0%/50%/55%/60%/65%/70%/75%/80%/85%/90%/95%)
		Operation monitoring of external equipment	At ON, displays the associated external equipment as Operation status, and at OFF, displays it as Stop status.	• a contact (ON at signal input, OFF at release)/ b contact (OFF at signal input, ON at release)
		Alarm monitoring of external equipment	At ON, displays the associated external equipment as Alarm detected status, and at OFF, displays it as No alarm.	• a contact (ON at signal input, OFF at release)/ b contact (OFF at signal input, ON at release)

Input/Output	I / O Function	Functions	Settings
Output	Control	Air conditioner alarm output	One or more specified air conditioners turn ON when an alarm occurs and turn OFF when the alarm goes OFF. • a contact (at ON, signal output, at OFF, output Stop) fixed
		Operation output	One or more specified air conditioners turn ON when operating, and turn OFF when all turn OFF. • a contact (at ON, signal output, at OFF, output Stop) fixed
		System alarm output	With this system excluding air conditioners, it turns ON when an alarm occurs and turns OFF when the alarm goes OFF. • a contact (at ON, signal output, at OFF, output Stop) fixed
		Refrigerant leakage output *During normal operation, do not set.	Turns ON when a refrigerant leakage signal is detected and turns OFF when the detection stops. • a contact (at ON, signal output, at OFF, output Stop) fixed * During normal operation, do not set.
		Operation output to external equipment	Turns ON when the associated external equipment is operated and turns OFF when stopped. • a contact (at ON, signal output, at OFF, output Stop) fixed

* Each function can be set in [Server/Interface] - [Interface Settings] in the Setting File Creation Software 2.

1-5. Energy Report Software 2

This software downloads data, such as indoor unit operating time and electric power consumption, from the System Controller, so the following functions can be used.

- Energy monitor screen: Allows you to use downloaded data to make graphs to visually check comparisons of operating data and to compare the past data of a specific unit or that of other indoor units, or for separate groups, such as floors or tenants.
- Report screen: Allows you to use the downloaded data to create monthly reports, daily reports, and more.

Function	Function outline	Note
Trend graph display	Displays a graph of electric power consumption and operating times of the air conditioners managed with the System Controller.	A graph can be displayed for days (in units of one hour), weeks (in units of one day), months (in units of one day), and years (in units of one month). In addition, a no-comparison graph can include outdoor temperature, indoor temperature, and set temperature.
Air conditioning load graph display	Displays a graph of the air conditioning load status of the air conditioners managed with the System Controller.	A graph can be displayed for cooling operation, heating operation, and overall air conditioning load in 11 levels. A graph can be displayed for days (in units of one hour), weeks (in units of one day), months (in units of one day), and years (in units of one month).
Ranking table of air conditioners	A ranking list can be displayed using the operating data of indoor units managed with the System Controller. You can display comparisons of each unit or group.	The electric power consumption and operating time can be compared.
Report output	Creates a report based on the operating results of each indoor unit measured by the System Controller.*	Reports can be exported in Excel [®] file format, CSV file format, or PDF file format.
Billing schedule settings	A billing schedule is a schedule you can set for when billed prices vary over multiple time periods or different days.	Even if a schedule is set, these settings are not reflected in the System Controller unless the billing schedule is uploaded. If you create or change a schedule, be sure to upload it.
Warning history display	You can display the history of warnings within a specified period.	

CAUTION

- Using the accumulated power meter with pulse output, the software calculates the distribution of power accumulated by pulse conversion according to the load proportion estimated for each air-conditioner. The result is not calculated based on the Measurement Act and cannot be used officially.
 - Even if the operation hour is the same, the amount of power consumed varies depending on operating conditions such as the location of the air-conditioner, the set temperature, and the outdoor temperature.
 - The air-conditioner stays on for protection, even while stopped, and power is consumed. Therefore the software also calculates power consumed while the air-conditioner is not in use.
 - The software calculates the distribution of power according to the load proportion estimated for each air-conditioner. Therefore the result may differ from the actual amount of power consumed.
 - If a single power meter is installed in multiple air-conditioners, the total power is distributed. The result may differ when a power meter is installed in each air-conditioner.
 - The software calculates the pulse output using the accumulated power meter with pulse output. The result may differ from the actual amount of power consumed depending on the precision of the power meter. In particular, when the amount of electricity consumed in operation is low (when stopped, etc.), the result may differ from the actual amount of power consumed.
 - Please note that we bear no responsibility for any damage or problems that occur due to the software's distribution calculation, data loss, etc.
 - The calculation result contains rounding errors.
 - The software only supports the distribution calculation of power consumed by the air-conditioner. Please note the above when you use it.
-

1-6. Remote monitoring

Settings for Remote Monitoring with a PC

You can monitor and control the Unit by accessing it from a PC. This section explains the settings for the Unit and the PC. Please see "9. Remote Monitoring Using a PC" (Owner's Manual P.98) for the system diagram and the PC operating environment.

NOTE

Some functions cannot be used from a PC. For details, please see "List by Lock Level/Level" (Owner's Manual P.111)

System diagram

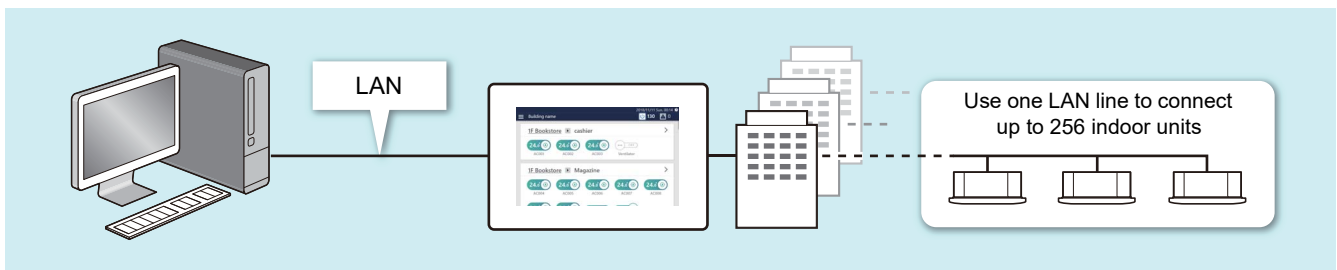

Unit settings

- 1** Set the user account for remote operation (Owner's Manual P.86)
- 2** Set the IP address (Owner's Manual P.89)
- 3** Set a destination to send email to when a malfunction occurs (Owner's Manual P.90)

PC settings

Settings

IP address/ Subnet mask	Set it to be the same network as the Unit. (Example: the Unit 192.168.2.80/PC 192.168.2.90/subnet 255.255.255.0)
Drive C	Ensure that you have 500 MB or more free space and start up as a user with read/write authority.

Operating environment

The following environment is necessary to use this function.

OS	Windows 10, Windows 11
.NET Framework	4.8
Web browser	Microsoft Edge, Google Chrome latest version

Install the software

- 1 Open the web browser of your PC
- 2 Access "[http://\[server name or IP address\]/touchscreencontroller/\[language code\]/download.html](http://[server name or IP address]/touchscreencontroller/[language code]/download.html)"

Server name or : Input the IP address that was set in "Set the IP address of the Touch screen controller" IP address (Owner's Manual P.89).

Language code: Enter the following value according to the language.

Language	Language Code
English	EN-UL
French	FR-UL
Spanish	ES-UL

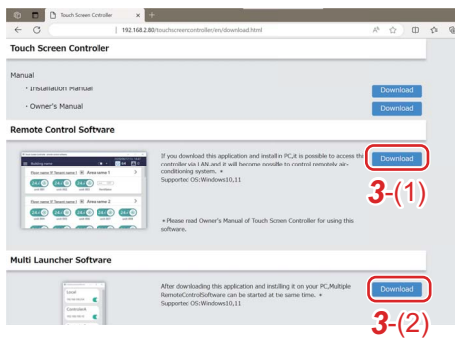

- 3 Click [3-(1)] *
- 4 Save the file according to the browser message
- 5 Double-click on the saved "installer_touchscreencontroller.exe" to unzip/install (setup.exe)

When the installation is completed, a shortcut icon is created on the desktop.



For remote monitoring of multiple system controllers with a PC, click [3-(2)] to similarly install the software.

A shortcut icon is created on the desktop when installation is complete.

NOTE

If .NET Framework 4.8 is not installed on the PC, this software will not work properly. Be sure to download and install .NET Framework 4.8 from the above website.

* About downloading the application

Depending on the browser and other settings, application download may be blocked or not executed due to security and other functions.

Please download selecting "Save" or "Download" from the download option menu.

Remote Monitoring Using a PC

You can monitor and control the Unit by accessing it from a PC. This section explains the system diagram and the operating environment. For settings, etc., see "Settings for Remote Monitoring with a PC" (P.36).

NOTE

Some functions cannot be used from a PC. For details, please see "List by Lock Level/Level" (Owner's Manual P.111).

Log in to Remote Control Software

NOTE

Up to 16 users can log in at the same time.



1 Double-click "AMTC_UI_****" on the desktop

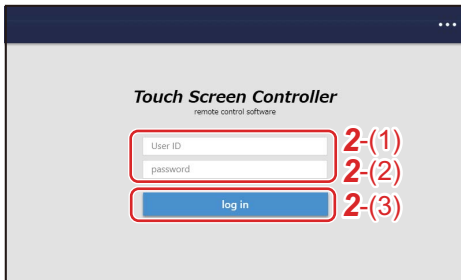

2 Enter [2-(1)] [2-(2)], then click [2-(3)]

User ID/password:

Use the user account set up in step **1** of "Unit settings" (P.36).

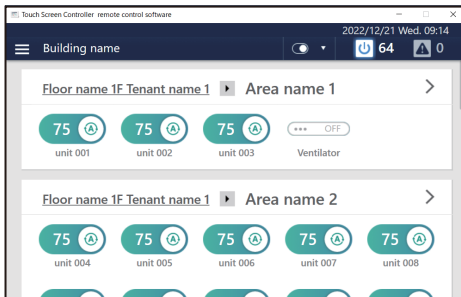

The Remote Control Software home screen is displayed.

Log out from Remote Control Software

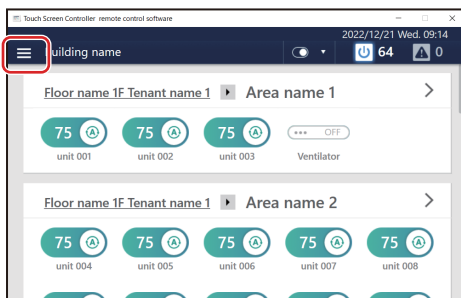

1 Click 

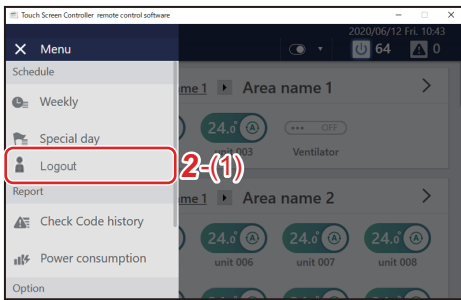

2 Click [2-(1)]

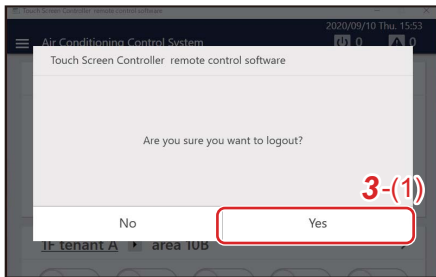

3 Click [3-(1)]
You are logged out from the Remote Control Software.

Exit Remote Control Software

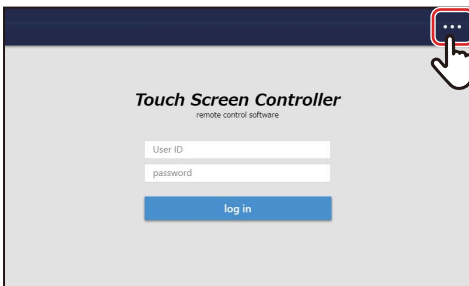

1 Tap ...

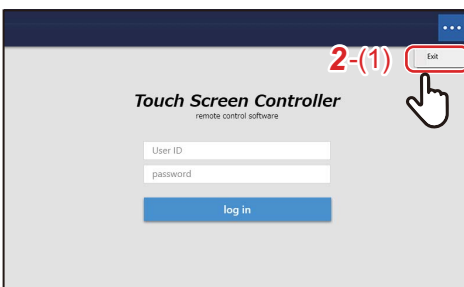

2 Tap [2-(1)]

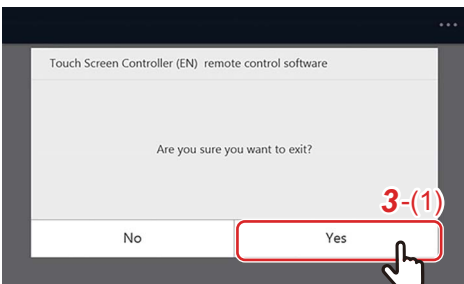

3 Tap [3-(1)]
Exit the Remote Control Software.

Configure the login settings for multiple system controllers



1 Double click [AMTC Launcher] on the desktop

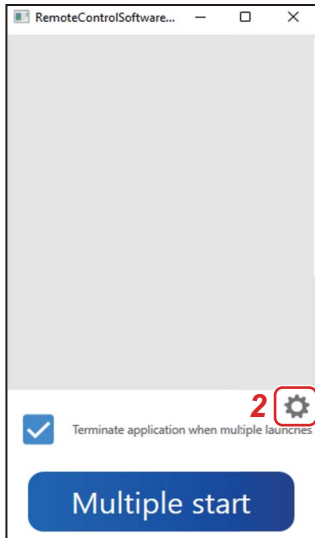

2 Click [2]

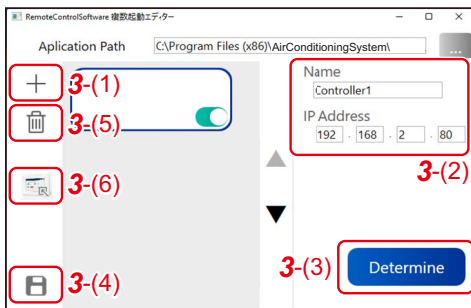

3
3.1 Click [3-(1)]

3.2 Set the name of the system controller in [3-(2)] Name and the IP address of the system controller in IP Address, and click the [3-(3)]

* To add multiple controllers, repeat Step **3.1** and **3.2** for each of the controllers.

3.3 Click [3-(4)] to close the window

• NOTE

- Settings can be deleted by clicking the [3-(5)].
- A shortcut for the login settings can be created by clicking the [3-(6)].

Log in to multiple system controllers



1 Double click [AMTC Launcher] on the desktop

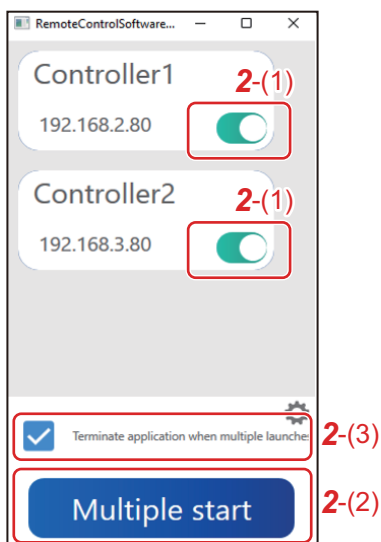

2 Turn the [2-(1)] of the system controller you wish to log in to ON, then click the [2-(2)]

The home screens of multiple Remote Control Software are displayed.

* If the [2-(3)] is selected, this window closes during startup.

2 System Configuration

2-1. System configuration diagram

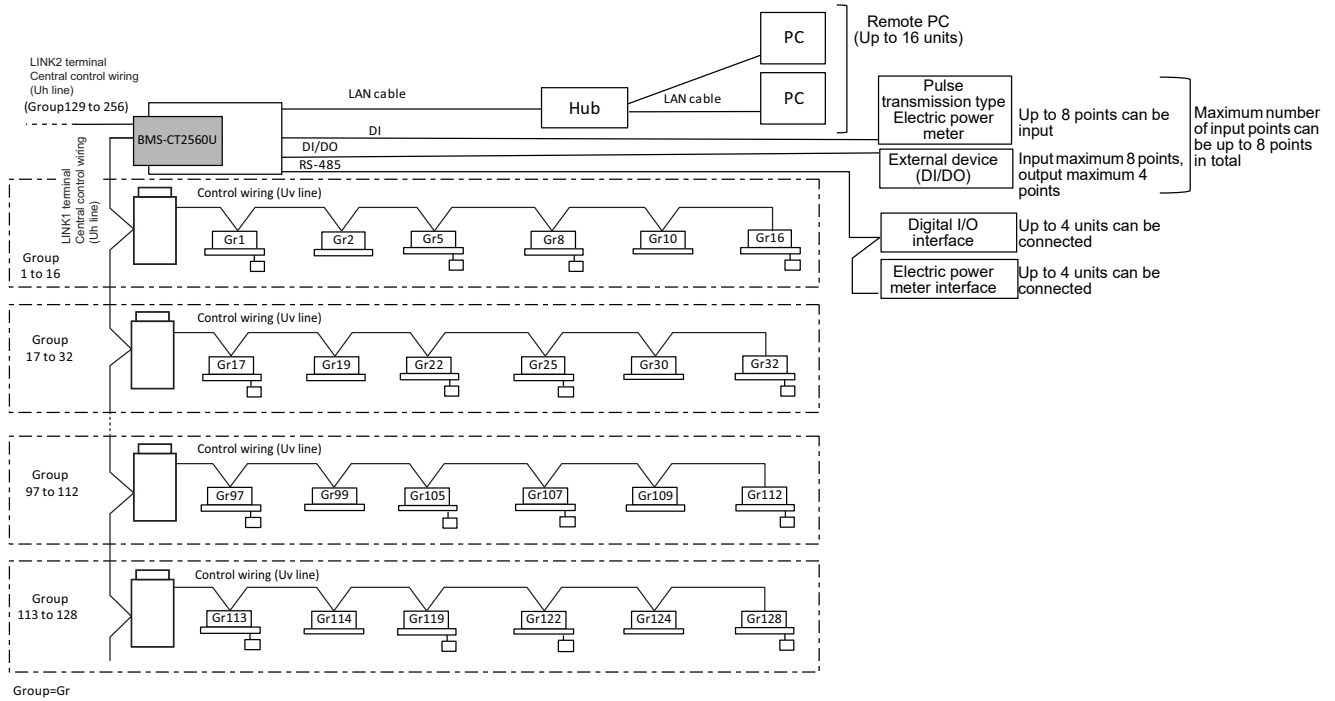

2-2. Outline drawing

■ Outline drawing

System Controller

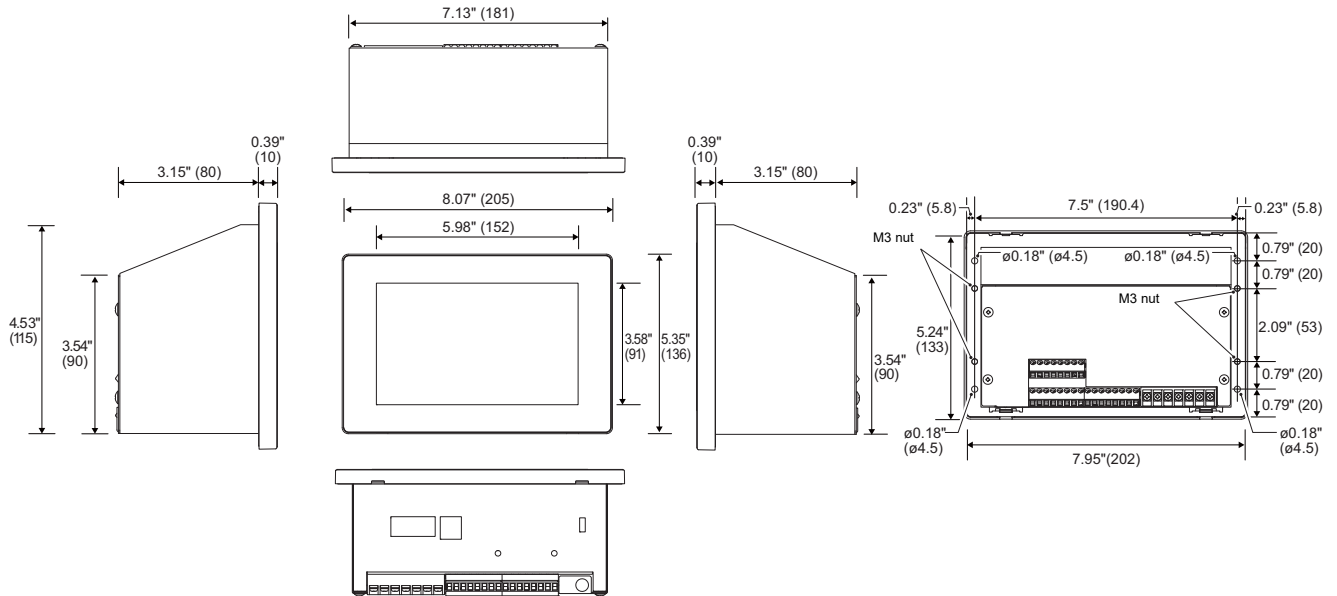

Power adapter

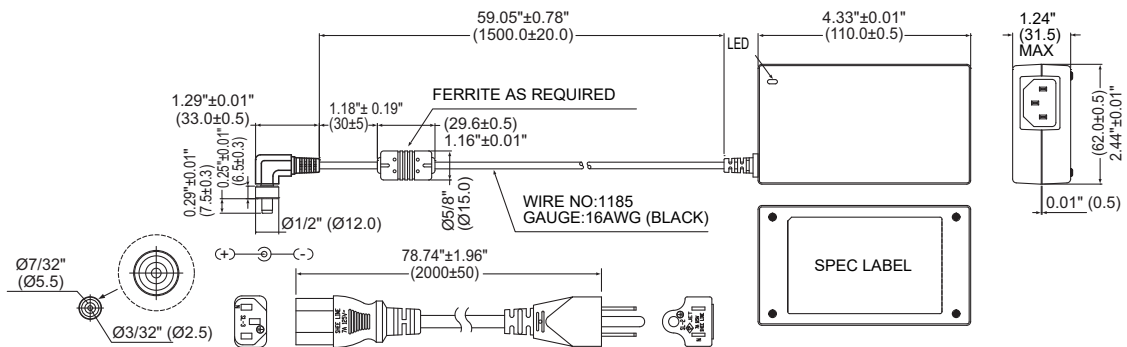

3 Initial Settings

You can select the initial setting procedure from the following three variations.

Regarding “3-3.Setting up by the controller only”, these settings cannot be done for models whose software version is earlier than 10.1.7.0.

Also, if you are setting up with just a controller, the following settings cannot be done.

- Linked control settings
- Master/slave settings for indoor units
- Floor and tenant settings
- Digital input/output interface and electric power meter interface settings
- Building name settings
- Power peak cut settings

3-1. Setup Using Template File of Setting File Creation Software 2 (SFC2)

Control functions that use power peak cut conditions cannot be set when using a template.

Set the control functions that use power peak cut conditions by the method that uses SFC2.

For details about the SFC2 functions, refer to the Owner's Manual for the setup file creation software 2.

When using the template function of the Setting File Creation Software 2

- (1)Start up the Setting File Creation Software 2, select [Tools] - [Export Template] - [Touch screen controller] - [BMS-CT2560U-UL]*, and then export a template file.
- (2)Input the various items, "Building Name", "IP Address", "Air Conditioner Information", "Digital I/O Interface", and "Electric Power Meter Interface", in the template file.



Template file sample

- (3)Start up the Setting File Creation Software 2. Select [Tools] - [Import] - [Touch screen controller] - [BMS-CT2560U-UL]*, and then import the data for the template file.

Uploading Setting Data

* If connecting to the LAN is difficult after the installation work, do "Uploading Setting Data" before "3-13.Installation work". If connecting to the LAN is easy after the installation work, then you could do "Uploading Setting Data" after "3-13.Installation work".

- (1) Confirm whether the settings match the system at the site.
- (2) Use a LAN cable to connect the Touch screen controller to the computer on which the Setting File Creation Software 2 is installed.
- (3) Turn on the power to the controller, and confirm that the HOME screen is displayed (takes about 4 minutes).
- (4) Put the computer's IP address to 192.168.2.80, the same network as the Touch screen controller.
- (5) Display the "Upload Settings" by using "File" - "Upload" in the Setting File Creation Software 2.
- (6) Use the [ping] button to confirm the connection to the Touch screen controller.
- (7) Use the "Upload" button to upload the setting file to the Touch screen controller.

3-2. Setup without Using a Template in SFC2

When not using the template function of the Setting File Creation Software 2

- (1) Start up the Setting File Creation Software 2. Select [Create New] - [Touch screen controller] - [BMS-CT2560U-UL]*, and then input each of the items, that were input for the "When not using the template function of the Setting File Creation Software 2" work, into the setting screen of the Setting File Creation Software 2.
Set the control functions that use power peak cut conditions by using the Setting File Creation Software 2.

Item	Data
Building name	
Lock Linkage Mode	0: Setting No.0
Simply Setting Mode Valid/Void	0: Void
Touch Screen Controller (CT128 Series) Group Setting	0: Header
Energy Monitoring	1: Valid(Distribution by capacity demand)
Stand-by power counting	1: Proportional sharing on indoor unit horse power codes.
Filter sign display mode	1: display
Select Touch Screen Display Language	0: Japanese
Temperature display: Interval	0: Unit 1 C.
Temperature display: C./F.	0: C.
Lower limit Temperature of Indoor unit graph	-10
Upper limit Temperature of Indoor unit graph	40
Dual Set Point Schedule Valid/Void (Use only Touch Screen Controller(CT128 Series) Ver 10.1.*.*)	0: Void
Decimal Separator Setting (.Dot) / ,(Comma) (Use only Touch Screen Controller(CT128 Series) Ver 10.1.*.*)	0: ,(Dot)
Daylight-saving time shift (minutes)	60
Flap Setting(group control)	0: Void
Memory refresh	0: Void
Display Leak Detection Valid/Void	0: Void
Power peak cut conditions	0: N/A
Power measurement method	1: Measurement method
CONTACT Info.	

Uploading Setting Data

* If connecting to the LAN is difficult after the installation work, do "Uploading Setting Data" before "3-13.Installation work". If connecting to the LAN is easy after the installation work, then you could do "Uploading Setting Data" after "3-13.Installation work".

- (1) Confirm whether the settings match the system at the site.
- (2) Use a LAN cable to connect the Touch screen controller to the computer on which the Setting File Creation Software 2 is installed.
- (3) Turn on the power to the controller, and confirm that the HOME screen is displayed (takes about 4 minutes).
- (4) Put the computer's IP address to 192.168.2.80, the same network as the Touch screen controller.
- (5) Display the "Upload Settings" by using "File" - "Upload" in the Setting File Creation Software 2.
- (6) Use the [ping] button to confirm the connection to the Touch screen controller.
- (7) Use the "Upload" button to upload the setting file to the Touch screen controller.

3-3. Setting up by the controller only

With this controller (software version 10.1.7.0 and later), air-conditioning units can be registered and area names and other settings below can be configured without using the Setting File Creation Software 2 that is required for conventional setup. A conventional setup using the Setting File Creation Software 2 is necessary when other settings are required.

Setting items that can be configured by the controller (without using the Setting File Creation Software 2)

No.	Setting Item	Setting Menu
1	Indoor unit registration	[Menu]-[Service settings]-[Central management address Setting]
2	Indoor unit area setting	[Menu]-[Indoor unit area setting]
3	Indoor unit name setting (single-byte alphanumeric characters only)	[Menu]-[Indoor unit name setting]
4	Area name setting (single-byte alphanumeric characters only)	[Menu]-[Area name setting]

3-4. How to Start and Stop Service Settings

The [Service settings] are normally hidden. You can use the following procedure to display the [Service settings] and open the service menu.

You can do operations for the following 10 items in [Service settings].

Item	Function
Cancel service mode	Exits the service menu and hides the [Service settings].
Outdoor DN	Change the DN setting value of connected outdoor units.
Digital IO Confirmation	You can confirm the state of digital input/output interfaces connected to or built-in to the main unit.
Check pulse input	You can display the pulse constant counted by the electric power meter interfaces connected to or built-in to the main unit.
Communication Quality	Displays the number of connected Uh and Uv lines, and their usage rate, retry rate, collision rate, and baud rate.
Comm settings	You can make the communication settings for the main unit.
Old controller setting	You can do the settings if you are combining use of Central Control Devices that are not compatible with TU2C-LINK.
Function settings	You can set remote controller less settings and the method for searching indoor units that are connected.
Comm software update	This screen is not used. Do not operate it.
Central management address Setting	You can set and change the Central management address of the indoor units.

Starting the service settings

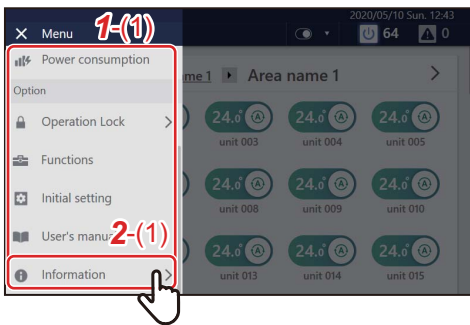

1 Tap 
[1-(1)] appears.

2 Scroll through the menu list and tap [2-(1)]
The Information screen appears.

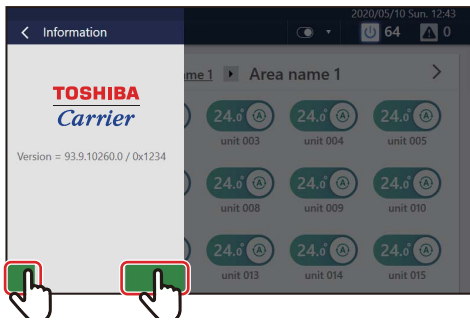

3 Tap and hold the lower left and lower right of the Information screen at the same time for about five seconds

After the sections that were tapped and held turn green, tap < to return to the menu.

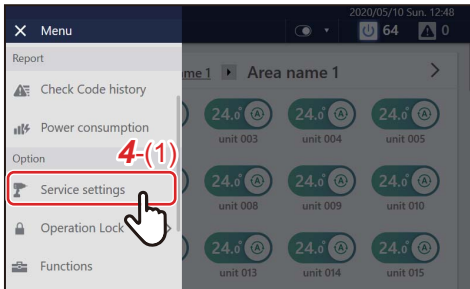

4 Tap [4-(1)]

The [Service settings] are displayed, and the service menu starts.

Exiting the service settings

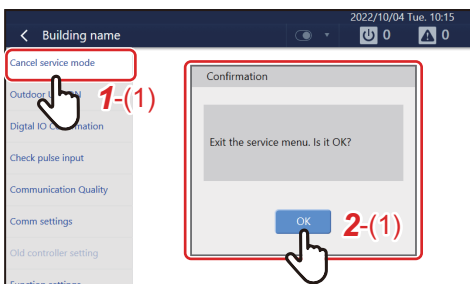

1 Tap [1-(1)]

2 Tap [2-(1)]

The service menu is exited, and the [Service settings] are hidden.

3-5. Outdoor DN settings

Starting settings for servicing

You can set the DN of the outdoor units connected to the unit.

1 Tap [1-(1)] in the settings for servicing

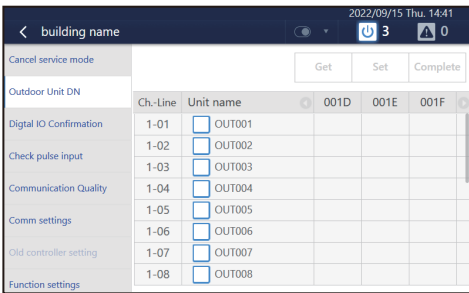
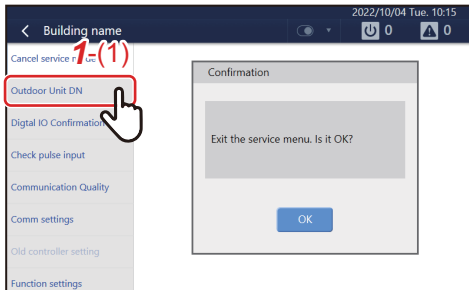

Acquire DN setting values

Acquire the DN setting value of the outdoor units connected to the unit.

1 Select the check boxes of the outdoor units whose DN setting values you want to acquire, and then tap [1-(1)]

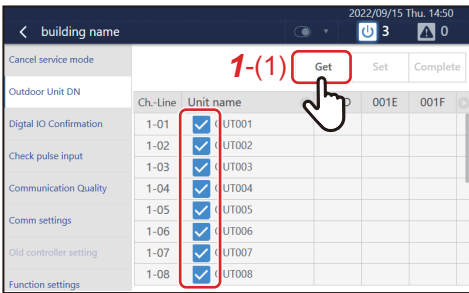

2 Tap [OK]

Start acquiring the DN setting values from the selected outdoor units.

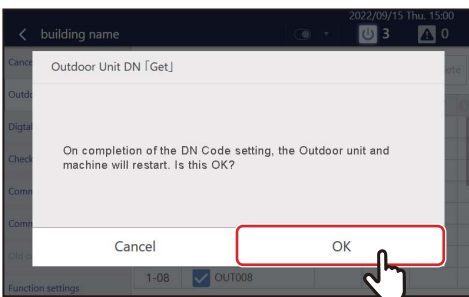

NOTE

To display the System cooperation defrosting settings display, select [Menu]-[Initial setting]-[Display] and enable [System cooperation defrosting settings].

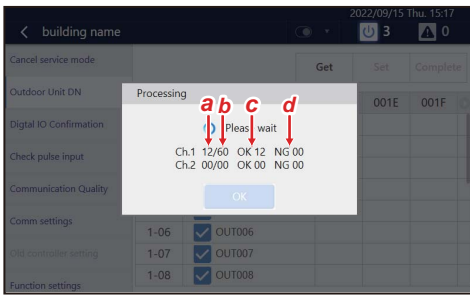

Acquisition of DN setting values from outdoor units is in progress. The states of the settings for the DN setting values are shown.

- a: Number of times process for DN acquisition and settings were completed
- b: Total number of units processed for DN acquisition and settings
- c: Number of times DN acquisition and settings succeeded
- d: Number of times DN acquisition and settings failed

3 Tap [OK]

Icon	Description
	The OK button can be tapped.
	The [OK] button cannot be tapped. It can be tapped when the process is complete.

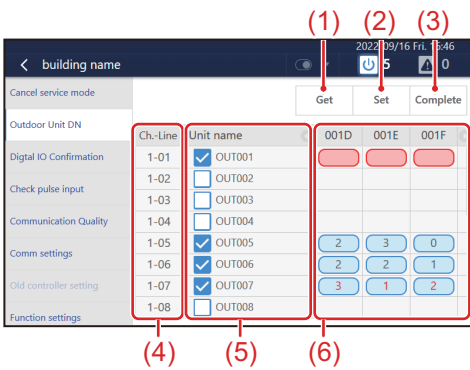

No.	Item	Description
(1)	Get	Acquires the DN setting values of the units whose check boxes are selected.
(2)	Set	Sets the DN value of the units whose check boxes are selected. If a check box is not selected, then nothing changes, even if the DN values are changed.
(3)	Complete	Exits this screen and restarts the unit and outdoor unit.
(4)	Addresses	Shows the "TCC-LINK channel number - refrigerant line address" of the unit.
(5)	Unit name	Shows the names of outdoor units that are connected to the unit. Tap a check box to select it.
(6)	DN items	Shows the DN settings acquired from the outdoor unit.*

* Shows icons of the DN items.

Icon	Description
	Items are displayed red if the DN setting values could not be acquired.
	Items are displayed blue if the DN settings values could be acquired.
	Numbers are displayed red if the DN settings were changed.

Change DN setting values

Change the acquired DN setting values.

1 Tap DN items you want to change

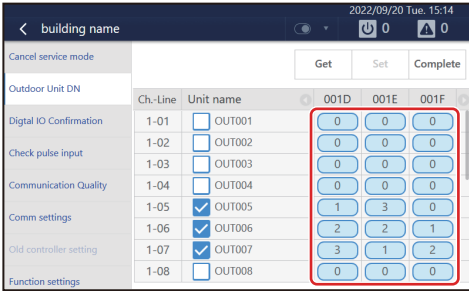

2 Tap or flick to set the setting values, and then tap [OK]
DN setting values that were changed are displayed red.

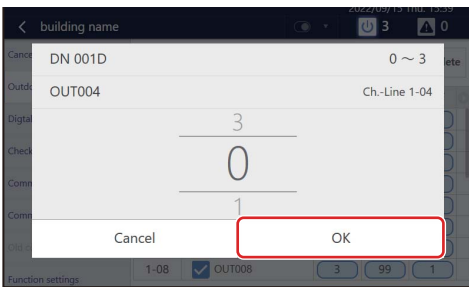

3 Tap [3-(1)]

At this point, the changes to the DN setting values have not been reflected to the outdoor units.



When the OK button turns blue, tap [OK] to close the dialogue screen.

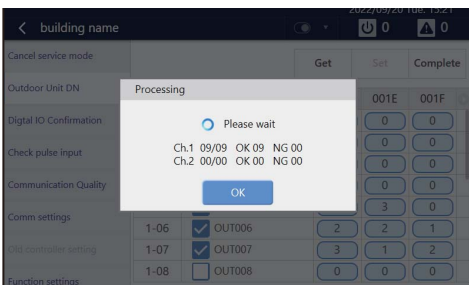

Exit the Outdoor Unit DN Settings Screen

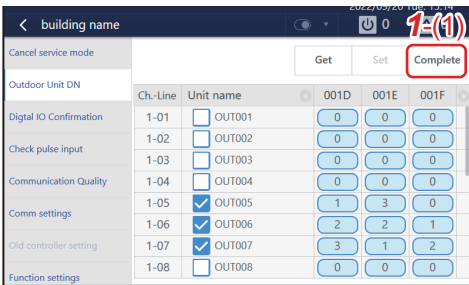

- 1 Tap [1-(1)]**
A popup screen appears.

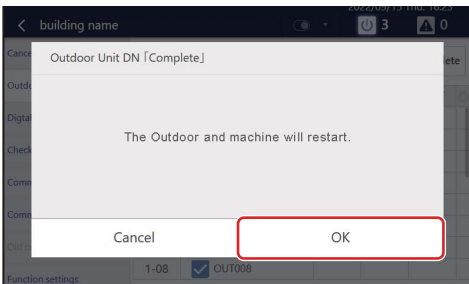

- 2 Tap [OK]**
The outdoor unit and unit restart.
The DN items that were set are reflected after the outdoor unit and unit have restarted.

3-6. Digital IO Confirmation

You can confirm operations of digital input/output connected to or inside the main unit.

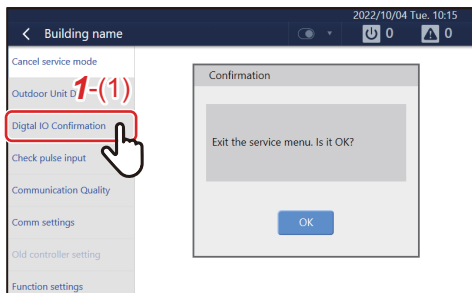

1 Tap [1-(1)] in the Service settings.

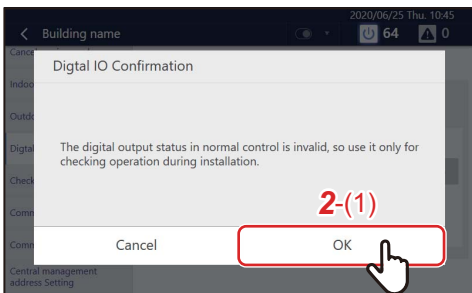

2 Tap [2-(1)].

"The digital output status in normal control is invalid, so use it only for checking operation during installation." is displayed.

Confirming Digital Input Signals



1 Tap [1-(1)].

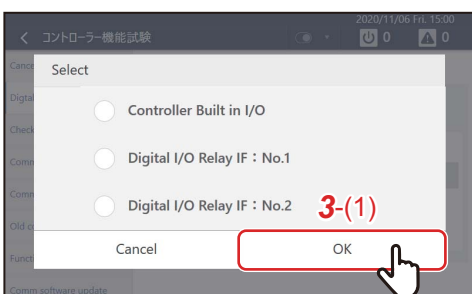

2 Select a digital input/output interface or I/O built-in to the main unit.

You can confirm the state of digital input/output interfaces that are connected to the main unit or the I/O built-in to the main unit.

Controller: "Controller Built in I/O"

Each IF: "Digital I/O Relay IF: No.x"

* x is the address

3 Tap [3-(1)].

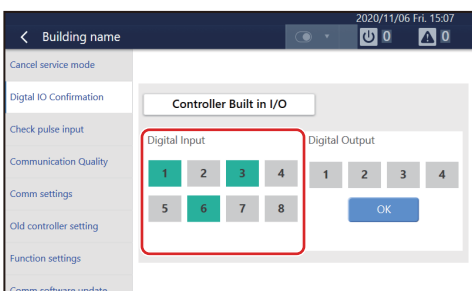

Digital Input is displayed.

Displays the state of the channels of either the I/O built-in to the main unit or the digital input/output interface, that was set up in steps 2 and 3.

- Displayed blue when signals are being input.
- Displayed grey when signals are not being input.
- Displayed greyed-out when they cannot be selected or controlled.

Confirming Digital Output Signals

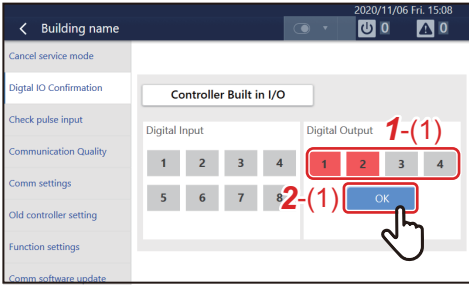

1 Tap [1-(1)] in Digital Output.

To confirm digital output signals, set the interface that you want to confirm in the same way as in steps 2 and 3 in "Confirming Digital Input Signals".

To confirm the signal is being output, tap the channel to confirm.

- If the channel is red, the output is controlled.
- If the channel is grey, the output is not controlled.

2 Tap [2-(1)].

Output control is executed.

Exiting Digital IO Confirmation

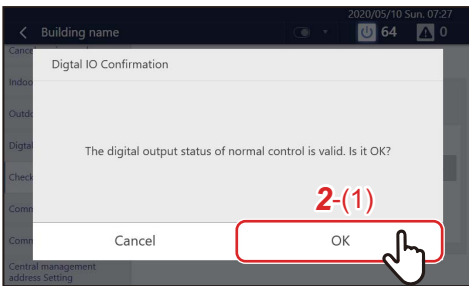

1 Do operation to move to another screen

"The digital output status of normal control is valid. Is it OK?" is displayed.

2 Tap [2-(1)].

3-7. Check pulse input

Displays the number of pulses counted in 30 seconds for each channel of the electric power meter interface that is set or the built-in I/O of the controller that is set for the electric power meter interface.

A "-" is displayed for channels that are not set for an electric power meter interface.

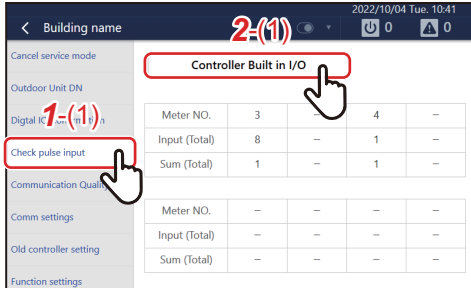

1 Tap [1-(1)] in the Service settings.

Meter NO.: Meter number

Input (Total): Total pulse count

Graph (Hour): Number of pulses counted within the last hour of the current time

2 Tap [2-(1)].

3 Select a controller or Diol/F (1-4) to display

Controller: "Controller Built in I/O"

Each IF: "Digital I/O Relay IF: No.x"

* x is the address

4 Tap [4-(1)].

The electric power pulse of the selected electric power meter is displayed.

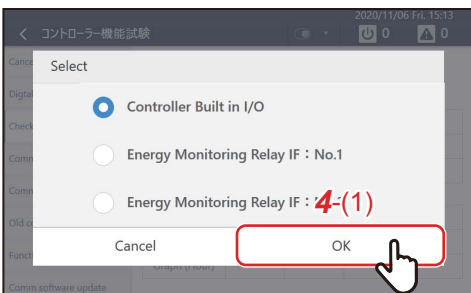

3-8. Communication Quality

The communication quality of the Uh and Uv lines for each channel are displayed.

Or, displays the number of each connected Uh and Uv line, and their usage rate, retry rate, collision rate, and baud rate. The displayed information is regularly updated every 30 minutes.

● **NOTE**

The Uv information is not displayed for outdoor units that do not support the communication quality display.

Ch.	Uh/Uv	No.	Count of units (units)	Usage rate (%)	Retry rate (%)	Collision rate (%)	Baud rate (bps)
CH.1	Uh	-	139	20	0	0.0	9600
CH.1	Uv	1	0	-	-	-	-
CH.1	Uv	2	0	-	-	-	-
CH.1	Uv	3	0	-	-	-	-
CH.1	Uv	4	0	-	-	-	-
CH.1	Uv	5	0	-	-	-	-
CH.1	Uv	6	0	-	-	-	-
CH.1	Uv	7	0	-	-	-	-
CH.1	Uv	8	0	-	-	-	-
CH.1	Uv	9	0	-	-	-	-

1 Tap [1-(1)] in the Service settings.

The usage rate, retry rate, and collision rate increase proportionally to the number of connected units.

If the usage rate, retry rate, and collision rate are high, even though there are only a few units connected, it could be caused by poor wiring installation or the incorrect type of wiring, etc.

3-9. Comm settings

This section explains how to do communication settings for the main unit.

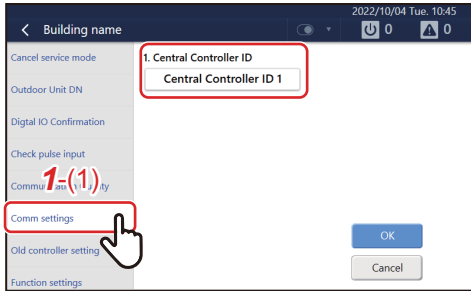

1 Tap [1-(1)].

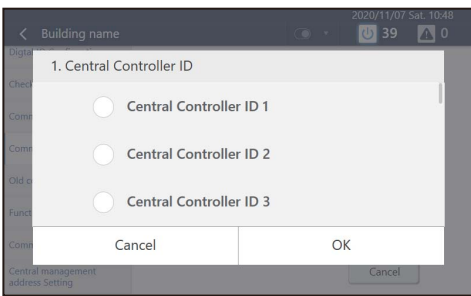

2 Set the Central Controller ID

Do the settings according to the following workflow.

Setting Workflow

1. Are 2 or more Central Control Devices connected?

Yes: Set to Central Controller ID 1.

No: Do setting 2.

2. Are 1 or more Central Control Devices that are not compatible with TU2C-LINK connected to the main unit?

Yes: Set the old controller.

No: Do setting 3.

3. For the Central Control Device model, with the best functions, being connected

Yes: Set Central Controller ID 1.

No: Set Central Controller ID 2 to 20.

NOTE

Set them so they are not the same as other Central Control Devices.

If the Central Controller IDs are duplicated, then abnormalities will occur on the duplicated controllers.

ID	Meaning
Central Controller ID 1	<p>Set under the following conditions</p> <ul style="list-style-type: none"> • Set only when the number of Central Control Devices connected is 1. • Do not set this when other Central Control Devices are being used in combination, and the main unit is being used as a master unit. * If Central Control Devices that are not compatible with TU2C-LINK are included, do the settings as for the old controller. * When connecting multiple Central Control Devices, be sure to set 1 unit as "Central Controller ID 1".
Central Controller ID2 to 20	<p>Set under the following conditions</p> <ul style="list-style-type: none"> • When combining use of other Central Control Devices and the main unit is a slave unit, set Central Controller IDs so they are not duplicated.
Old controller	<p>Set under the following conditions</p> <ul style="list-style-type: none"> • Set when Central Control Devices, that include models that are not compatible with TU2C-LINK, are used in combination with the main unit. * To execute this setting, be sure to do the settings according to the "Old controller setting" screen on page 60.

3 Tap the OK button



CAUTION

If you change the following settings, turn off the power of the connected "Multi outdoor unit" after "SMMS-u" and turn it back on.

- Central Controller ID1 - 20 → Old Controller
- Old Controller → Central Controller ID1 - 20

3-10. Old controller setting

This setting screen is for combining Central Control Devices that are not compatible with TU2C-LINK.

* This screen can only be set if "Old controller setting" is selected in the "Comm settings" screen.

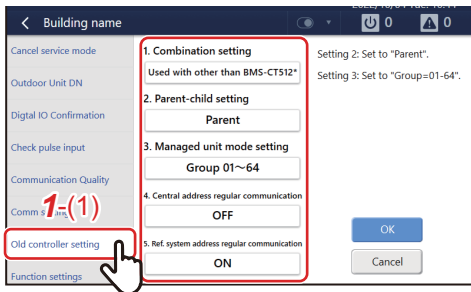

1 Tap [1-(1)].

1 Combination setting

Select models to use in combination.

Item	Description
Used with other than BMS- CT512*	Set when used with models other than BMS-CT512*. (The address used when doing TU2C-LINK communications is 0x300)
Used with BMS-CT512*	Set when used with BMS-CT512*. (The address used when doing TU2C-LINK communications is other than 0x300)

2 Parent-child setting

When using in combination with Smart BMS manager or web compatible central remote controller

- Smart BMS manager/web compatible central remote controller: Setting not needed
- Main unit: Set as slave unit

Item	Description
Parent	Set this when the main unit is used independently or is used as a master unit connected to other Central Control Devices. (Put only one master unit on TU2C-LINK.)
Child	Set this when there are 2 or more main units or other Central Control Devices are being used in combination and one is being used as a slave unit. (Put only one master unit on TU2C-LINK.)

• NOTE

When "used with BMS-CT512*" is set in the combination settings, this setting cannot be changed. The address used when doing TU2C-LINK communications is changed.

3 Managed unit mode setting

Do not change this setting from the initial value (ALL group).

• NOTE

When "Used with BMS-CT512*" is set in the combination settings, this setting cannot be changed.

4 Central address regular communication

Do not change this setting from the initial value (OFF).

5 Ref. system address regular communication

This setting turns periodic communications between indoor units and outdoor units on and off.

Item	Description
ON	Set one of the main units to "ON" if at least one of the following conditions is applicable. <ul style="list-style-type: none">• There is only one Central Control Device• There are 2 or more main units used in combination• There is another Central Control Device used in combination (Periodic communication is executed.)
OFF	Set to "OFF" if conditions are different from those above. (Periodic communication is not executed.)

3-11. Function settings

You can set remote controller less settings and the method for searching indoor units that are connected.

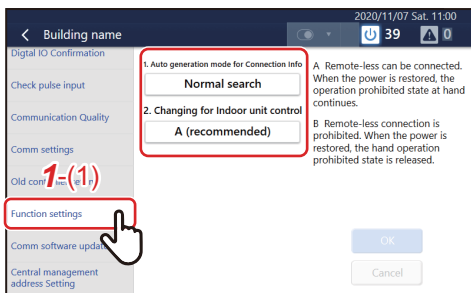

1 Tap [1-(1)].

1 Auto generation mode for Connection info

Item	Description
Normal search	<p>Search air conditioners by using line indoor address.</p> <ul style="list-style-type: none"> If the line indoor address is not set, you cannot confirm connections. Custom (package) indoor units will not operate normally if duplicate refrigeration system numbers are set in the refrigeration systems 1 to 28. If an address is set that does not operate normally, set the central management address for the custom (package) indoor unit at the local remote controller, and then change the search settings to central management address search. <p>[Duplicate indoor unit number in system] Does not operate normally</p> <ul style="list-style-type: none"> Indoor unit A: Refrigeration system number = 1, Indoor unit number = 1 Indoor unit B: Refrigeration system number = 1, Indoor unit number = 1 <p>[No duplicate indoor unit number in system] Operates normally</p> <ul style="list-style-type: none"> Indoor unit A: Refrigeration system number = 1, Indoor unit number = 1 Indoor unit B: Refrigeration system number = 2, Indoor unit number = 2 <p>[No duplicate indoor unit number in system] Operates normally</p> <ul style="list-style-type: none"> Indoor unit A: Refrigeration system number = 29, Indoor unit number = 1 Indoor unit B: Refrigeration system number = 29, Indoor unit number = 2
Full search	<p>Search for air conditioners by using central management address.</p> <ul style="list-style-type: none"> If the central management address is not set, you cannot confirm connections. Set when used with BMS-CT512*. <p>(The address used when doing TU2C-LINK communications is other than 0x300)</p>

2 Changing for indoor unit control

With indoor units that are not compatible with TU2C-LINK, you can set whether to connect by remote controller less or to prohibit local operations after recovering from a power outage.

Item	Description
A (recommended)	<ul style="list-style-type: none"> It is possible to connect a remote controller less unit. When the power is shut down and then restored, prohibition of remote control operations is continued.
B	<ul style="list-style-type: none"> It is not possible to connect a remote controller less unit. A warning is detected if the remote controller is disconnected. When the power is shut down and then restored, prohibition of local remote control operations is released.

* When 2 or more Central Control Devices are connected, do the same settings for all the Central Control Devices.

* The B settings cannot be done if a controller is connected that periodically communicates with the indoor units, once every 4 seconds, such as a 128 Touch screen controller or 64 Central remote controller (not compatible with TU2C-LINK).

Settings to Connect a Unit That Has No Remote Control

When you use a remote controller less unit to connect indoor units that are compatible with TU2C-LINK, you need to use one of the following methods to do remote controller less settings for the indoor unit. If these settings are not done, a Check Code E03 (Indoor - Remote controller communication error) is detected.*1

- On the wired remote controller or energy-saving neo remote controller, change DN [103] from 0 (with remote controller) → 1 (remote controller less)
- On the System Controller being used, change DN [103] from 0 (with remote controller) → 1 (remote controller less) for the relevant indoor units*2

1 Limited to compatible remote controller (RBC-AMSU51).

*2 Limited to compatible Central Control Devices.

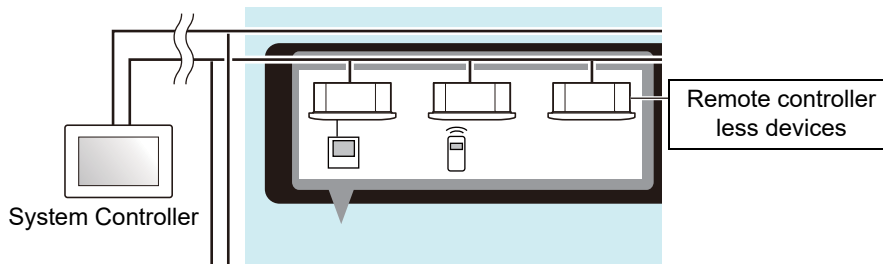

3-12. Comm software update

This screen is not used. Do not operate it.

3-13. Installation work

Installs the main unit. For the installation method, refer to the installation manual that came with the product.

3-14. Trial operation

- (1) Confirm that the settings are reflected on the Touch screen controller(CT256series) screen normally by switching ON/OFF, changing the set temperature, and changing the Mode from the remote control of each air conditioner.
- (2) From the Touch screen controller(CT256series) screen, switch ON/OFF, change the set temperature, and change the Mode and confirm that the air conditioners operate normally.

4 Troubleshooting

	Phenomenon	Question	Confirmation items
1	The LCD does not display.	Is the power turned on?	Check that the power is not turned off by the breaker or the like. There is a green LED at the lower rear of the main unit and a green LED on the AC adapter that indicate that power is being supplied.
2			Check that the wiring of the power outlet and AC adapter is not disconnected. There is a green LED at the lower rear of the main unit and a green LED on the AC adapter that indicate that power is being supplied.
3		Has the backlight gone out?	The LCD turns off when there is no operation for a certain period of time. Touch the touch panel to turn on. The brightness and display time can be changed using [Backlight].
4		Is the backlight brightness dark?	Adjust the brightness using [Backlight].
5	The operated air conditioner does not run.	Does the operated air conditioner match the actual air conditioner?	Operate another air conditioner and check if the actual air conditioner operates.
6		Has a check code been detected?	The air conditioner will not operate when a check code has been detected. Erase the check code.
7		Are you operating with the local remote control?	Even if the air conditioner is run with this Unit, if it is stopped afterwards with the local remote control, it will stop. The latter operation of this Unit or the local remote control overrides the former.
8		Is the air conditioner stopped due to the schedule setting of the local remote control or the like?	Even if the air conditioner is run with this Unit, if it is stopped afterwards with the local remote control schedule, it will stop. The latter operation of this Unit or the local remote control overrides the former.
9		Are you operating with the PC app "Remote Control Software"?	Even if the air conditioner is run with this Unit, if it is stopped afterwards with the PC app "Remote Control Software", it will stop. The latter operation of this Unit or the "Remote Control Software" overrides the former.
10	I want to turn off the power.	From [Menu], turn off the power.	Select [Menu]-[Functions]-[shut down].
11	I want to reboot.	Reboot from the menu.	Select [Menu]-[Functions]-[System reboot].
12	The air conditioner settings change arbitrarily.	Are you operating with the local remote control?	Even if the air conditioner is run with this Unit, if it is stopped afterwards with the local remote control, it will stop. The latter operation of this Unit or the local remote control overrides the former.
13		Is the air conditioner stopped due to the schedule setting of the local remote control or the like?	Even if the air conditioner is run with this Unit, if it is stopped afterwards with the local remote control schedule, it will stop. The latter operation of this Unit or the local remote control overrides the former.
14		Have you applied settings such as stop using an external input signal?	When stop, etc. is set by an external input signal using the external interlocking function, the air conditioner stops automatically when a signal is input.
15		Are you operating with the PC app "Remote Control Software"?	Even if the air conditioner is run with this Unit, if it is stopped afterwards with the PC app "Remote Control Software", it will stop. The latter operation of this Unit or the "Remote Control Software" overrides the former.
16	The schedule does not work.	Is the schedule disabled?	Please confirm the Scheduler Operation settings.
17		Does the scheduled air conditioner match the actual air conditioner?	Operate another air conditioner and check if the actual air conditioner operates.
18		Is a Special day schedule set?	If a day is set in both the Weekly schedule and a Special day schedule, the Special day schedule will apply for that day.

	Phenomenon	Question	Confirmation items
19	The air conditioner doesn't cool. The air conditioner doesn't heat.	Is demand control turned on?	Demand control suppresses the capability of the outdoor unit in order to reduce power consumption. Therefore, it may take time to reach the set temperature.
20		Is the forced thermo OFF control turned on?	Forced thermo OFF is a control to stop the operation of the outdoor unit. Therefore, the indoor unit acts as a fan.
21		Is the power saving control turned on?	Power saving suppresses the capability of the outdoor unit. Therefore, it may take time to reach the set temperature.
22	The LCD does not turn off.	Has a check code been detected?	The LCD will still be on when a check code has been detected. Erase the check code.
23	Sometimes the LCD becomes black for a moment.	The LCD's antistatic control is working.	Temporarily stop the LCD periodically to prevent LCD burn-in. Not a malfunction.
24	The setting displayed on the local remote control does not match the setting displayed on this Unit.	Does the operated air conditioner match the actual air conditioner?	Operate another air conditioner and check if the actual air conditioner operates.
25	When local remote control operation is prohibited, if there is a power failure, the local remote control prohibited status will be cancelled when the power returns.	-	Set [Menu] - [Service settings] - [Function settings] as shown below. Set [Changing for indoor unit control] to [A].
26	FILTER information can be reset even when the FILTER sign is not displayed.	The FILTER signs lights up depending on the accumulated operation time.	As the operation time accumulates, the FILTER sign lights up when the preset operation time is reached. The FILTER sign information can be reset to clear the accumulated time for cases such as when FILTER cleaning is carried out before the FILTER sign turns on.
27	I want to check the software version.	Reboot from the Information menu.	The version is displayed under [Menu] - [Information].
28	The webpage of the Controller is not displayed.	Is the power to the System Controller on?	If the power to the System Controller is not on, you cannot connect to the webpage. Confirm if the power is on.
29		Is the LAN cable connected?	The webpage is not displayed unless the PC and the LAN of this Unit are connected. Check the LAN cable connection and network settings.
30		Have you set the IP address?	You cannot connect to the Unit unless the IP address of the PC is set. For details, see (P.26 in Owner's Manual).
31		Do you use a proxy server?	If the setting is such that a proxy server is used, exclude the IP address of the System Controller.
32	Reboot from time to time.	Please check for noise and the power supply status.	The main unit may restart if noise in the surroundings or an unstable power supply cause the operation of the software to be unstable. Please check the surrounding environment.
33	I cannot start the Remote Control Software.	Is "Error 1001" displayed?	Please download .Net Framework 4.6.2 from the download website of this software and install it.
34		Is the LAN cable connected?	This software will not start unless the PC and the LAN of this Unit are connected. Check the LAN cable connection and network settings.
35		Is the IP address of the access destination set to the IP address of the controller main unit?	The IP address (or server name) to be entered during installation is the IP address of the controller main unit. It is not the IP address of the PC. If it is incorrect, please do the following and then reinstall. 1. Uninstall the application 2. Delete the install destination directory 3. Delete the desktop and start menu shortcuts
36		Is the PC on which the software was installed Windows 10?	Windows 10 is supported. The software may not operate correctly when installed on a PC with a different OS.

	Phenomenon	Question	Confirmation items
37	I cannot log in to the Remote Control Software.	Have you logged in as the same user from another PC?	Each user can log in from only one PC at the same time.
38		Is the Windows display style set to classic style?	Please select a display style other than classic style. You can change the display style from [Start] - [Control Panel] - [Appearance and Personalization] - [Change the theme]. This software supports Windows 10.
39	I cannot log in to Remote Control Software from another PC after the LAN is disconnected.	Have you logged in with the same user ID?	You must log in again from a PC with the LAN disconnected and log out normally.
40		Have you accessed the software from more than 8 PCs?	Up to 8 PCs can be accessed at the same time. The software may not operate correctly if you connect to more than 9 PCs.
41		Did you assign the PC's IP address using a DHCP server?	This Unit judges whether it is accessed from the same PC using the IP address. If the PC address is changed partway through by the DHCP server, you may not be able to log in again after LAN disconnection. Please set the PC that accesses this Unit to a fixed IP or reboot the Unit and erase the login information.
42	The language does not switch with the Remote Control Software.	Does the login user for the Windows being used have write permission for the Remote Control Software storage location?	Please allow write permission below the folder where Remote Control Software is saved (initial setting: C:\Program Files\AirConditioningSystem). Right-click on the AirConditioningSystem folder, select the [Properties] - [Security] Name, click the "Edit" button and check [Allow] for [Full control] under different settings.
43	The schedule setting changes have not been reflected.	Are you trying to change the schedule settings on both the Remote Control Software and the main unit?	To change the schedule settings, please set only one of either the main unit or the Remote Control Software.
44	I would like to use the software with other centralized controllers.	Centralized controllers that can be used together within the same network.	It is possible to use up to 8 units together with all centralized controllers including this Unit. Ask service personnel to use them in combination.
45	I want to use multiple units in combination.	Number of units that can be used in combination in the same network.	It is possible to use up to 8 units together with all centralized controllers including this Unit. Ask service personnel to use them in combination.
46	The LCD sometimes turns black for a moment.	The LCD's antistatic control is working.	This is not a malfunction. The LCD may turn black temporarily to remove static electricity.
47	The multi outdoor unit's option board control does not work.	Do you want to use the multi outdoor unit's option board?	When the centralized controller is connected, the functions of the outdoor unit's option board become ineffective. Only one of the centralized controller and the outdoor unit's option board can be used.
48	The Unit does turn ON/OFF even though the operation interlock signal/stop interlock signal is input.	Has the interlock signal been input from the time of activation?	Since the interlock signal confirms the state by detecting the rising edge and falling edge, if the interlock signal is input from the time of activation, interlock control will not be performed. Please set so that the interlock signal turns OFF at the time of activation.
49	Check code L20 (Duplicated central control addresses) has occurred.	Have you set the same central management addresses for two or more indoor units?	When connecting to the Central Control Device, it is necessary to register a separate number for the central management addresses for each indoor unit. If you accidentally register the same central management addresses in different indoor units, the Central Control Device or remote controller will detect the L20 (Duplicated central control addresses) check. Review the central management addresses (DN03) setting for each indoor unit.

About L20 (Duplicated central control addresses) Warnings

When you connect the System Controller, set a central management address (DN03) for each indoor unit. Central management addresses require that you register separate numbers for each indoor unit, but if you mistakenly register the same central management address for different indoor units, an L20 (duplicated central control addresses) warning will be detected by System Controller or the local remote control.

With TU2C-LINK, the System Controller detects an L20. With TCC-LINK, the remote controls belonging to the individual indoor units detect an L20. The System Controller, which is incompatible with TU2C-LINK, may not be able to detect an L20, depending on conditions*, if the indoor unit is compatible with TU2C-LINK. Be sure to do a one-to-one test for the System Controller and indoor units.

There are some models on which you can check for duplications on the central management address list screen, depending on the model of the System Controller.

* Central Control Devices whose model name does not contain "U"

[Conditions]

When the same central management address is set for indoor units using different coolant systems in a system of outdoor units and indoor units that are compatible with TU2C-LINK and a Central Control Device that is incompatible with TU2C-LINK.

Check Code List

Check Code	Check Code Names
A00	No error
A01	Flow switch operation error
A02	Water temperature decrease error
A04	Activation of water heat exchanger frost protection
A06	Ignition failed
A27	Abnormal increase at temperature sensor for refrigerant heating outlet
A31	Other thermal component error
C05	Sending error in TCC-LINK central control device
C06	Receiving error in TCC-LINK central control device
C12	Batch alarm of general-purpose interface
C15	Error codes for thermal storage unit
E01	Communication error between indoor and remote controller
E02	Sending error of remote controller
E03	Communication error between indoor and remote controller
E04	Communication circuit error between indoor and outdoor
E06	Decrease of No. of indoor units
E07	Communication circuit error between indoor and outdoor
E08	Duplicated indoor addresses
E09	Duplicated master remote controllers
E10	Communication error between indoor P.C.board
E11	Communication error between indoor-sub-PCB, sub-PCB-option PCB
E12	Automatic address start error
E13	Periodic communication error (DX-kit - 0-10V_I/F) at indoor unit - 0-10V_interface
E14	Periodic communication error between indoor unit and 0 to 10V interface
E15	No indoor automatic address
E16	Capacity over/No. of connected indoor units
E17	Bad reception from flow selector (FS) unit
E18	Communication error between indoor header and follower units
E19	Outdoor header units quantity error
E20	Other line connected during automatic address
E21	Header thermal storage units quantity error
E22	Decrease of No. of thermal storage units
E23	Sending error in communication between outdoor units
E25	Duplicated follower outdoor address
E26	Decrease of No. of connected outdoor units
E28	Follower outdoor unit error
E31	IPDU communication error
F01	Indoor TCJ sensor error
F02	Indoor TC2 sensor error
F03	Indoor TC1 sensor error
F04	TD1 sensor error
F05	TD2 sensor error
F06	TE1/TE2 sensor error
F07	TL sensor error
F08	TO sensor error

Check Code	Check Code Names
F09	TG sensor error
F10	Indoor TA/TSA sensor error
F11	Indoor TF/TFA sensor error
F12	TS1 sensor error
F13	TH sensor error
F14	TR sensor error
F15	Outdoor temp. sensor misconnection (TE1/TL)
F16	Outdoor pressure sensor misconnection (Pd/Ps)
F17	TOA sensor error
F18	TRA sensor error
F19	Indoor heat exchanger temperature sensor (TF) error
F20	PL (fluid piping pressure) sensor error
F22	TD3 sensor error
F23	Ps sensor error
F24	Pd sensor error
F25	Indoor heat exchanger temperature sensor (TA) error
F26	Indoor heat exchanger temperature sensor (TC2) error
F29	Indoor other error
F30	Occupancy sensor error or indoor air cleanliness error
F31	Outdoor EEPROM error
H01	Compressor break down
H02	Magnet switch / Overcurrent operation / Compressor error
H03	Current detection circuit error
H04	Comp-1 case thermo operation
H05	Outdoor temp. sensor misconnection (TD1)
H06	Low pressure protective operation
H07	Low oil level protection
H08	Oil level temp. sensor error
H14	Comp-2 case thermo operation
H15	Outdoor temp. sensor misconnection (TD2)
H16	Oil level circuit / Magnet switch / Overcurrent error
H25	Outdoor temp. sensor misconnection (TD3)
H26	Compressor winding error
H27	Compressor inverter board error
H28	Compressor winding error
J01	Flow selector (FS) unit has bad reception from indoor unit (main unit)
J02	Communication error between flow selector (FS) unit boards and between MCUs
J03	Flow selector (FS) unit is duplicated
J10	Float SW operating at flow selector (FS) unit
J11	TCS sensor error in flow selector (FS) unit
J12	Sensor 2 error in flow selector (FS) unit
J28	Refrigerant leak detection(GL-17)
J29	Refrigerant leak sensor error
J30	Refrigerant leak detection
J31	Refrigerant leak sensor life
L02	Inconsistency error of outdoor units

Check Code	Check Code Names
L03	Duplicated indoor header units
L04	Duplicated outdoor line address
L05	Duplicated indoor units with priority
L06	Duplicated indoor units with priority
L07	Group line in individual indoor unit
L08	Indoor group/Address unset
L09	Indoor capacity unset
L10	Outdoor capacity unset
L11	Absence of flow selector (FS) unit
L12	Flow selector system error
L13	Safety device mismatch
L14	No safety device connected
L17	Inconsistency error of outdoor units
L18	FS unit error
L20	Duplicated central control addresses
L21	200 V applied voltage error
L22	There are units in the group that do not support DX-KIT.
L23	Setting abnormality
L24	Flow selector unit is set incorrectly
L26	Over No. of conneced thermal strage units
L27	Thermal storage units quantity error
L28	Maximum number of outdoor units exceeded
L29	No. of IPDU error
L30	Auxiliary interlock in indoor unit
L31	IC error
P01	Indoor fan motor error
P02	Boost circuit error
P03	Discharge temp. TD1 error
P04	High-pressure switch detection error
P05	Phase-missing detection / Phase order error
P07	Heat sink overheat error
P08	Intake air temperature error
P09	Other error
P10	Indoor overflow error
P11	Outdoor heat exchanger freeze trouble
P12	Indoor fan motor error
P13	Outdoor liquid back detection error
P14	Other cycle protection
P15	Gas leak detection
P16	Injection circuit trouble
P17	Discharge temp. TD2 error
P18	Discharge temp. TD3 error
P19	4-way valve inverse error
P20	High-pressure inverse error
P22	Outdoor fan IPDU error
P24	Other error

Check Code	Check Code Names
P25	Compressor inverter board error
P26	Compressor energization error
P27	Active filter error
P28	Active filter miswiring
P29	Comp position detection circuit error
P30	Group terminal unit error
P31	Follower indoor unit error (Group error)
S01	Communication error between air conditioner and BMS
S02	BMS-IFLSV Communication error
S03	Group terminal unit error
S04	BMS-IFWH Communication error
S06	BMS-IFWH Communication error
S07	BMS-IFDD Communication error
S08	Communication error
S09	Communication error
S12	Other error
S14	Start failure
S15	File access error
S16	IP address setup error
S17	File load error
S18	BMS-IFWH initialization communication incomplete
S19	BMS-IFDD initialization communication incomplete
S20	Initialization between air conditioner and BMS is not completed
S21	Mail transmission error
S22	Internal communication error
S23	Setting file read error
S25	Schedule file read error
S26	Schedule file write error
S27	Daily report/Monthly report file read error
S28	Daily report/Monthly report file write error
S29	Application error
S30	System error
S32	Alarm activation
S33	System controller address duplication error
3A01	Pump or flowing quantity error
3A02	Temperature increase error
3A03	Temperature increase error (hot water supply)
3A04	Antifreeze operation
3A05	Piping antifreeze operation
3A07	Pressure switch operation
3A08	Low pressure sensor operation error
3A09	Overheat protection operation (Thermostat of the backup heater)
3A10	Antifreeze operation 2

Check Code	Check Code Names
3A11	Operation of the release protection
3A12	Heating, hot water heater error
3A13	Pump error
3C05	Sending error in TCC-LINK central control device
3C06	Receiving error in TCC-LINK central control device
3C12	Batch alarm of general-purpose interface
3C15	Error codes for thermal storage unit
3.00E+01	Communication error between indoor and remote controller
3.00E+02	Sending error of remote controller
3.00E+03	Communication error between indoor and remote controller
3.00E+04	Communication circuit error between indoor and outdoor
3.00E+06	Decrease of No. of indoor units
3.00E+07	Communication circuit error between indoor/outdoor
3.00E+08	Duplicated indoor addresses
3.00E+09	Duplicated master remote controllers
3.00E+10	Communication error between indoor P.C.board
3.00E+11	Communication error at optional PCB in indoor unit
3.00E+12	Automatic address start error
3.00E+13	Periodic communication error (DX-kit - 0-10V_I/F) at indoor unit - 0-10V_interface
3.00E+14	Periodic communication error between indoor unit and 0 to 10 V interface
3.00E+15	No indoor automatic address
3.00E+16	Capacity over/No. of connected indoor units
3.00E+17	Bad reception from flow selector (FS) unit
3.00E+18	Communication error between indoor header and follower units
3.00E+19	Outdoor header units quantity error
3.00E+20	Other line connected during automatic address
3.00E+21	Header thermal storage units quantity error
3.00E+22	Decrease of No. of thermal storage units
3.00E+23	Sending error in communication between outdoor units
3.00E+25	Duplicated follower outdoor address
3.00E+26	Decrease of No. of connected outdoor units
3.00E+28	Follower outdoor unit error
3.00E+31	IPDU communication error
3F01	Indoor TCJ sensor error
3F02	Indoor TC2 sensor error
3F03	TC sensor error
3F04	TD sensor error
3F05	TD2 sensor error

Check Code	Check Code Names
3F06	TE sensor error
3F07	TL sensor error
3F08	TO sensor error
3F09	TG sensor error
3F10	TWI sensor error
3F11	TWO sensor error
3F12	TS1 sensor error
3F13	TH sensor error
3F14	TTW sensor error
3F15	Outdoor temp. sensor misconnection (TE1/TL)
3F16	Outdoor pressure sensor misconnection (Pd/Ps)
3F17	TFI sensor error
3F18	THO sensor error
3F19	Detection of THO disconnection error
3F20	TFI sensor error
3F23	Low pressure sensor error
3F24	Pd sensor error
3F25	Indoor heat exchanger temperature sensor (TA) error
3F26	Indoor heat exchanger temperature sensor (TC2) error
3F29	EEROM error
3F30	Extended IC error
3F31	Outdoor EEPROM error
3F32	Flow sensor error
3H01	Compressor break down
3H02	Magnet switch / Overcurrent operation / Compressor error
3H03	Current detection circuit error
3H04	Comp-1 case thermo operation
3H05	Outdoor temp. sensor misconnection (TD1)
3H06	Low pressure protective operation
3H07	Low oil level protection
3H08	Oil level temp. sensor error
3H14	Comp-2 case thermo operation
3H15	Outdoor temp. sensor misconnection (TD2)
3H16	Oil level circuit / Magnet switch / Overcurrent error
3J01	Flow selector (FS) unit has bad reception from indoor unit (main unit)
3J03	Flow selector (FS) unit is duplicated
3J10	Float SW operating at flow selector (FS) unit
3J11	TCS sensor error in flow selector (FS) unit

Check Code	Check Code Names
3J12	Sensor 2 error in flow selector (FS) unit
3L02	Combination error
3L03	Duplicate main Hydro unit during Group control
3L04	Duplicated outdoor line address
3L05	Duplicated indoor units with priority
3L06	Duplicated indoor units with priority
3L07	Communication error
3L08	Indoor group/Address unset
3L09	Communication error
3L10	Outdoor capacity unset
3L12	Flow selector system error
3L15	Other error
3L16	Setting error
3L17	Inconsistency error of outdoor units
3L18	FS unit error
3L20	Duplicated central control addresses
3L21	200 V applied voltage error
3L22	There are units in the group that do not support DX-KIT.
3L23	Setting abnormality
3L24	Flow selector unit is set incorrectly
3L26	Over No. of conneced thermal strage units
3L27	Thermal storage units quantity error
3L28	Maximum number of outdoor units exceeded
3L29	No. of IPDU error
3L30	Auxiliary interlock in indoor unit
3L31	IC error
3P01	Indoor fan motor error
3P02	Boost circuit error
3P03	Discharge temp. TD1 error
3P04	High-pressure switch detection error
3P05	Phase-missing detection / Phase order error
3P07	Heat sink overheat error
3P08	Intake air temperature error
3P09	Other error
3P10	Indoor overflow error
3P12	Indoor fan motor error
3P13	Outdoor liquid back detection error
3P15	Gas leak detection

Check Code	Check Code Names
3P17	Discharge temp. TD2 error
3P19	4-way valve inverse error
3P20	High-pressure inverse error
3P22	Outdoor fan IPDU error
3P24	Other error
3P26	G-Tr short circuit protection error
3P29	Comp position detection circuit error
3P30	Group terminal unit error
3P31	Slave Hydro unit error which occurs when error occurs in master Hydro unit
4	Serial signal error
7	Case thermo error
0C	TA sensor (Room temperature sensor) error
0D	TC sensor (Heat exchanger temperature sensor) error
0E	Refrigerant leak sensor error
0F	TCj sensor (Heat exchanger temperature sensor) error
11	Indoor fan motor error
12	Indoor P.C. board error
14	Inverter error
16	Inverter error
17	Current sensor error
18	TE sensor (Outdoor heat exchanger temperature sensor) or TS (Suction pipe temperature sensor) error
19	TD sensor (Discharge pipe temperature sensor) error
1A	Outdoor fan motor error
1B	TO sensor (Outdoor temperature sensor) error
1C	Compressor system or other error
1D	Compressor does not rotate
1E	TD sensor (Discharge pipe temperature sensor) over limit
1F	Compressor break down
21	High pressure is detect
25	Refrigerant leak detection
26	Gas detector sensor error(only bi-flow)
41	UART communication error between RAC IF to RAC

5 Service Parts

No.	Component name	Component code	Overview	Q'ty
1	Power adapter	4316V581	Power supply adapter for Touch screen controller	1

Installation Manual

Central Control Device (Touch Screen Controller) Installation Manual

For commercial use

Model name:

BMS-CT2560U-UL

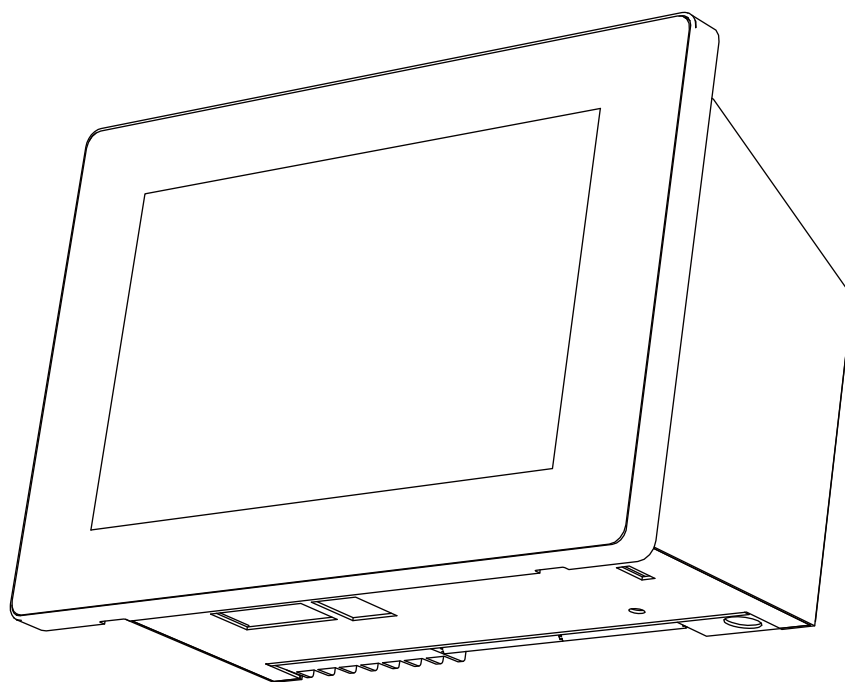

• Save These Instructions!



•Thank you for purchasing the system controller.
•Please read this installation manual carefully before installation, and perform the work only in the correct manner.

Contents





1	Precautions for safety	3
2	Specifications	5
3	Installation	8
3-1.	Installation of Main Unit Box and Panel	8
3-1-1.	When Installing from the Front	8
3-1-2.	When Installing from the Rear	9
3-2.	Attaching the Power Adapter	10
3-3.	Power, Signal, and Ground Line Connections	11

1 Precautions for safety



- Read these “Precautions for safety” carefully before installation.
- The precautions described below include important items regarding safety. Observe them without fail. Understand the following details (indications and symbols) before reading the body text, and follow the instructions.
- After the installation work has been completed, perform a trial operation to check for any problems. Explain how to use and maintain the unit to the customer.
Ask customer to keep this Manual at accessible place for future reference.

Indication	Meaning of Indication
 WARNING	Text set off in this manner indicates that failure to adhere to the directions in the warning could result in serious bodily harm (*1) or loss of life if the product is handled improperly.
 CAUTION	Text set off in this manner indicates that failure to adhere to the directions in the caution could result in serious bodily injury (*2) or damage (*3) to property if the product is handled improperly.

- *1: Serious bodily harm indicates loss of eyesight, injury, burns, electric shock, bone fracture, poisoning, and other injuries which leave aftereffect and require hospitalization or long-term treatment as an outpatient.
 *2: Bodily injury indicates injury, burns, electric shock, and other injuries which do not require hospitalization or long-term treatment as an outpatient.
 *3: Damage to property indicates damage extending to buildings, household effects, domestic livestock, and pets.

Symbols	Meaning of Symbols
	“  ” Indicates prohibited items. The actual contents of the prohibition are indicated by a picture or text placed inside or next to the graphic symbol.
	“  ” Indicates compulsory (mandatory) items. The actual contents of the obligation indicated by a picture or text placed inside or next to the graphic symbol.

WARNING

	<ul style="list-style-type: none"> • Ask an authorized dealer or qualified installation professional to install or reinstall this unit. Inappropriate installation may result in electric shock or fire. • Electrical work must be performed by a qualified electrician in accordance with this installation manual. The work must satisfy all local, national and international regulations. Inappropriate work may result in electric shock or fire. • Be sure to turn off all main power supply switches before starting any electrical work. Failure to do so may result in electric shock.
	<ul style="list-style-type: none"> • Do not modify the unit. A fire or an electric shock may occur.
	<ul style="list-style-type: none"> • Always connect to ground Improper grounding may result in an electric shock. Before connecting the power, carry out Class D grounding according to the “Engineering Standard for Electric Work” and the “Internal Wiring Regulations”.

 **CAUTION****• Do not install in the following locations:**

- Locations where combustible gas may leak
- Locations with high humidity or water
- Dusty locations
- Locations in direct sunlight and locations subject to high temperatures
- Locations within 3.28 ft (1 m) from televisions or radios
- Outdoors, under awnings, or other locations exposed to rain and dew
- Locations exposed to outside air containing corrosive gases or salinity
- Locations with frequent vibrations

• Do not operate the touch panel with mechanical pencils or other pointed objects.**• In installation work, use wiring with the correct ampacity.**

Failure to do so may result in excessive heat or fire.

• Use specified cables and connect them securely, and do not subject connecting terminals to external force.

Doing so may result in broken cables, excessive heat or fire.

• Always install a circuit breaker on the primary side of the power supply.**• Clean the touch panel by wiping with an eyeglasses cleaner or other soft cloth.**

To remove oil-based ink, wipe with a cloth that has been moistened with a neutral detergent and then wrung out, and finish by wiping with a soft, dry cloth.

Do not use commercial OA cleaners, cleansers, or other liquid cleaners containing abrasives.

• When attaching to a metal lath, wire lath or wooden structure with metal boards, attach it to the control panel, etc. without attaching it to the wall.**• Do not swallow the coin cell battery.**

There is a risk of injury due to chemical reaction if the battery is accidentally swallowed.

CAUTION This device uses a lithium battery. Follow all local regulations when disposing of it.

2 Specifications

Product name		Touch Screen Controller
Model Name		BMS-CT2560U-UL
Power supply		AC 120 V 60 Hz
Consumed current		1.17 A
Number of connected units	Indoor unit	Up to 256 units (LINK1 terminal: maximum 128 units, LINK2 terminal: maximum 128 units)
	ON/OFF unit	Maximum 60 units
	ENERGY MONITORING RELAY INTERFACE	Up to 4 units
	DIGITAL INPUT/OUTPUT RELAY INTERFACE	Up to 4 units
Communication ports		<ul style="list-style-type: none"> •RS-485 port ×1 •LAN port ×1
USB port		USB memory stick connection port ×2
External contact input		8 inputs
External contact output		4 outputs
Operating temperature/humidity range		32 to 104°F (0°C to 40°C), 10% to 90% RH (no condensation)
Dimensions		H5.35"(136 mm)×W8.07"(205 mm)×D0.39"(10 mm)+3.15" (+80 mm) (Embedded dimensions shown in parenthesis)
Mass		2.95 lb (1.34 kg) (System Controller) 0.99 lb (0.45 kg) (power adapter)

EN

■ Outline drawing

Unit: inch (mm)

System Controller

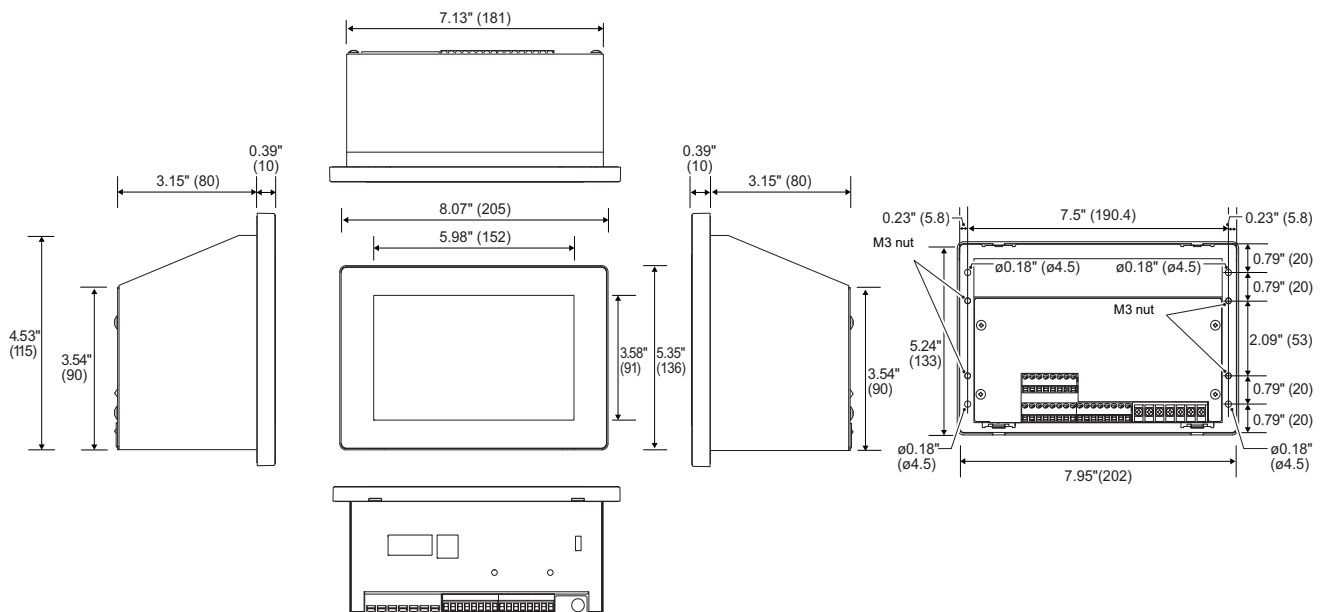

Power adapter

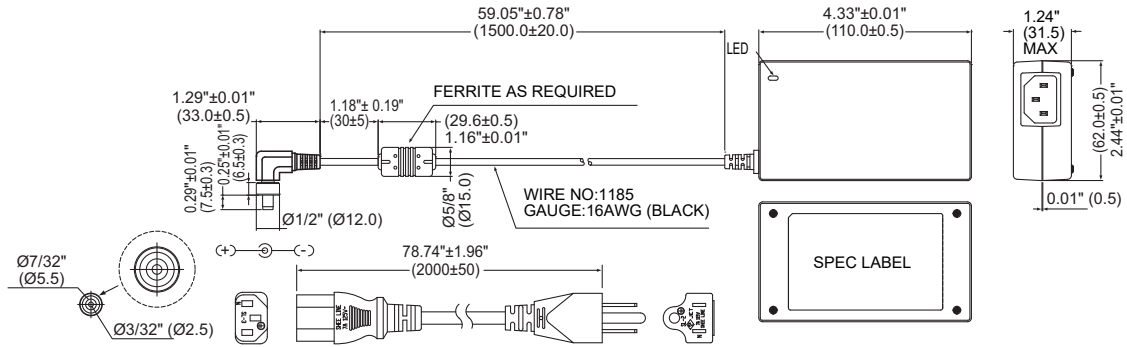

Component Names

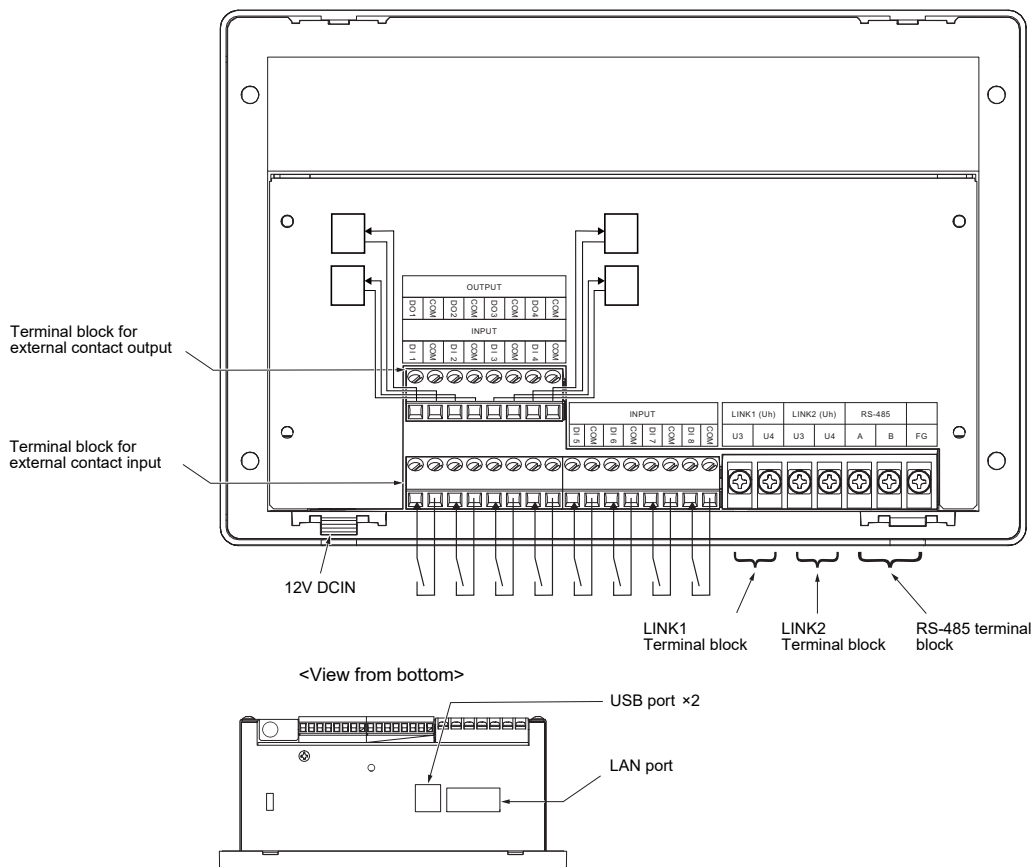

Name	Function
12V DCIN	Connect the power adapter
Terminal block for external contact output	Connect the external contact output
Terminal block for external contact input	Connect the external contact input
LINK terminal block	Connect the central control wiring
RS-485 terminal block	Connect the RS-485 terminal block
USB	For service
LAN	Can be connected to a PC via LAN communication and monitored and controlled

■ Before Installation

Confirm that all the parts listed below are included in the package.

Included Items

No.	Component name	Quantity	Remarks
1	System Controller	1	
2	Power adapter	1	
3	Power cable	1	
4	Owner's Manual	1	
5	Installation Manual	1	
6	Fixing screw	4	Fixing screw (M4×0.47" (12 mm)) for attaching the main unit from the front
7	Fixing screw	4	Fixing screw (M3×0.31" (8 mm)) for attaching the main unit from the rear
8	Closed end connector	2	RS-485 cable crimp connector
9	Cable tie	2	For fixing the power adapter
10	Double-sided tape	1	For fixing the power adapter

Wiring specifications

Use the following wiring material to connect signal wires and power supply wires. (Locally procured)

No.	Wiring	Wire type / wire diameter / wire length
1	For LINK terminal	Refer to "Design of Control Wiring" (P.13).
2	For RS-485	2-core shielded wires
		AWG16 . Up to 1640.5ft (500 m) (total extension distance)
3	For digital I/O	Two-core cable AWG22 . Up to 328.1ft (100m)
4	For Ethernet	LAN cable (category 5 or above) Maximum length: 328.1ft (100m)

3 Installation

⚠ CAUTION

- Do not wire communication lines or input/output wiring next to power supply wiring, etc., or house them in the same metal pipe. Doing so may result in failure.
- Install the main unit away from noise sources.

3-1. Installation of Main Unit Box and Panel

The main unit box can be mounted either from the front or from the rear.

3-1-1. When Installing from the Front

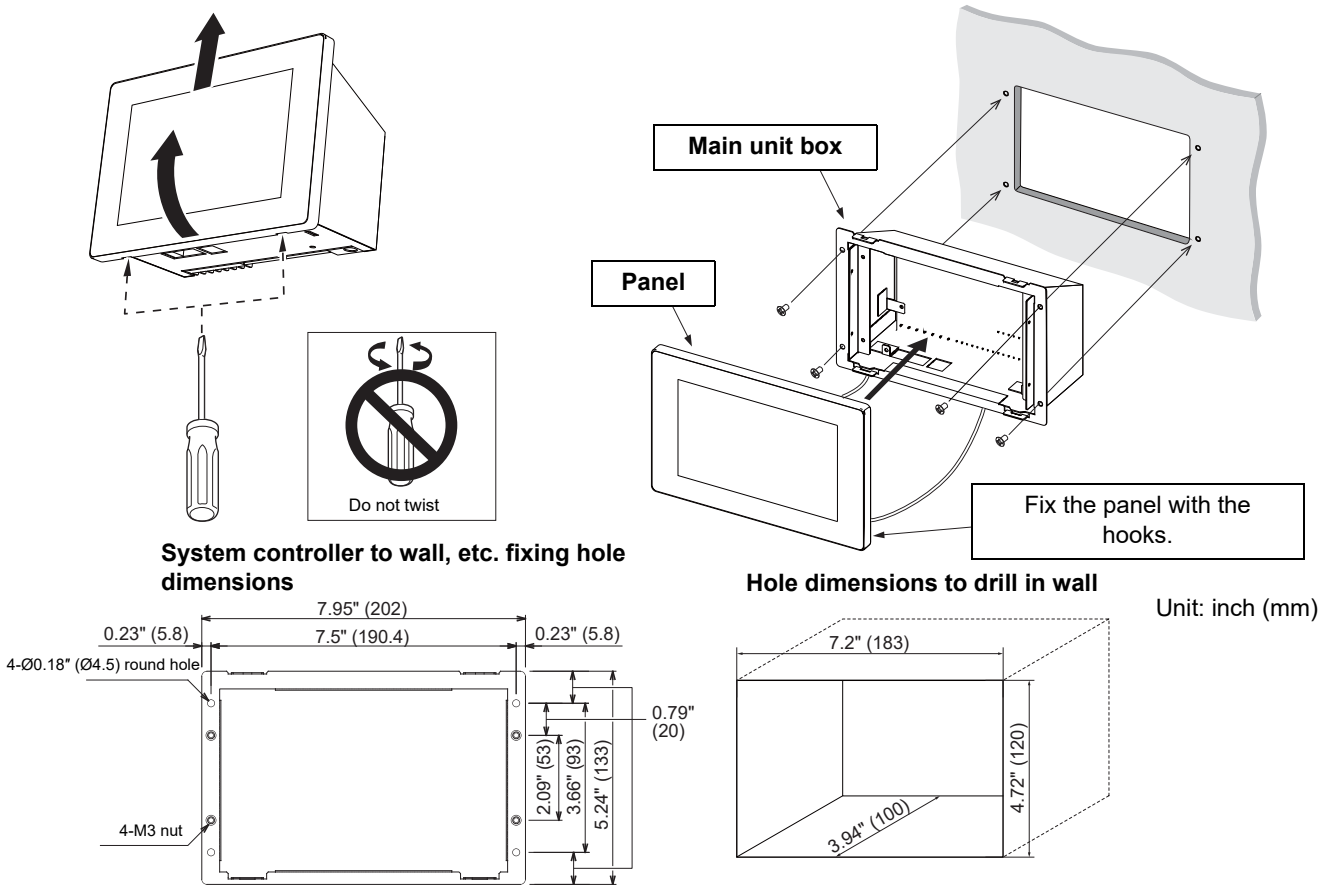

* Since the left and right mounting screws are attached close to each other, please drill the left and right dimensions as accurately as possible.

- 1 Connect the TU2C-LINK cable, AC adapter, and LAN cable to the main unit.
- 2 Fit the main unit on to the wall and switch board.
- 3 Insert a flat head screwdriver, etc. into the groove on the left and right of the bottom of the panel. There will be a snapping sound and the panel will come off.

REQUIREMENT

- Just insert the screwdriver and do not twist it.
- To prevent the panel from falling, support it during removal.

- 4 Fix the 4 main unit screws.
- 5 Close the panel by hooking the panel rear to the top of the main unit. There will be a snapping sound and the panel will be fixed.
- 6 When installation is completed, peel off the transparent film.

3-1-2. When Installing from the Rear

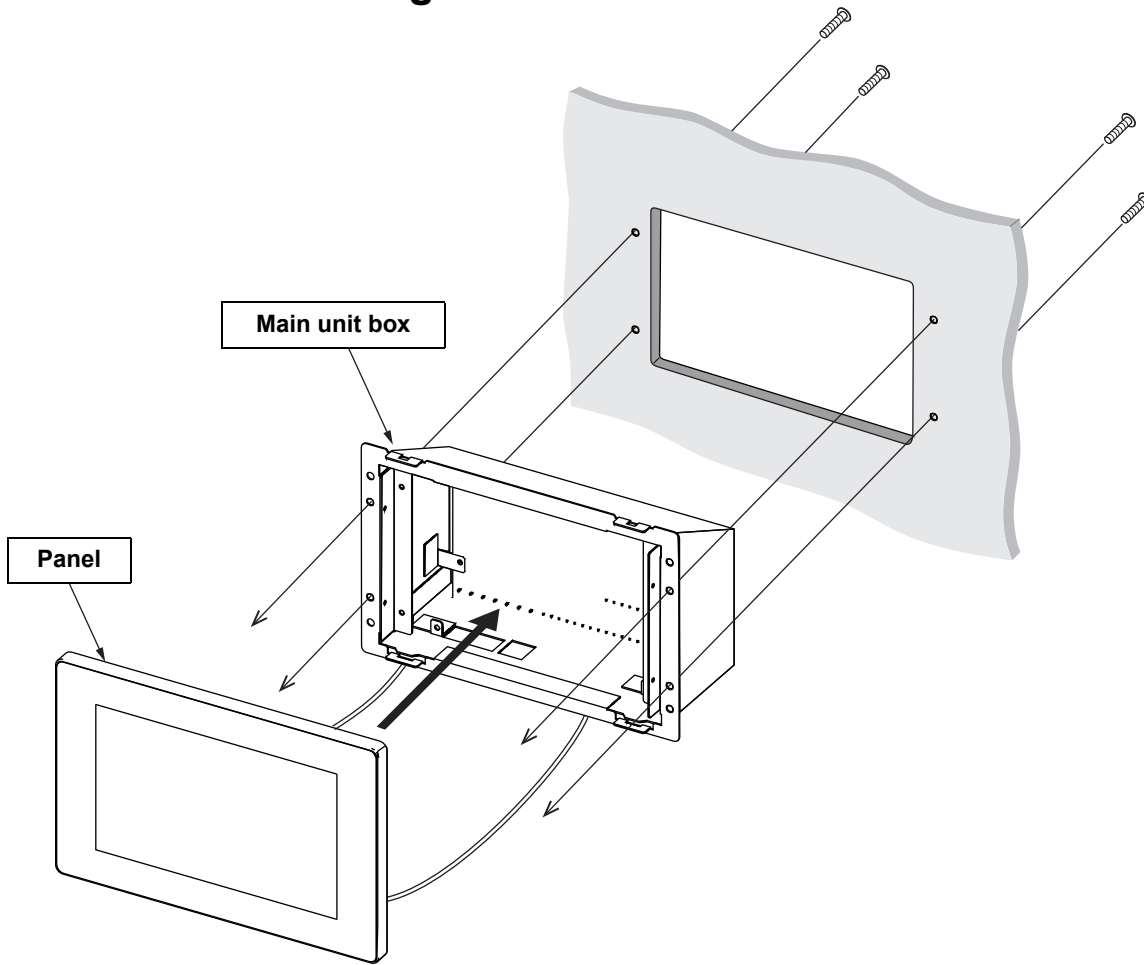

EN

System controller to wall, etc. fixing hole dimensions

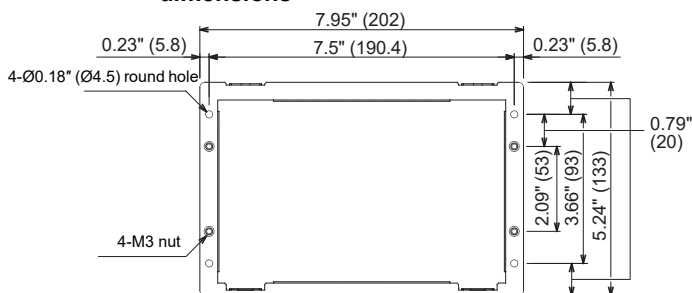

Hole dimensions to drill in wall

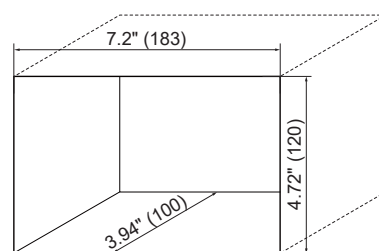

Unit: inch (mm)

* Although the panel and the main unit box are separated to explain the screw attachment part in an easy to understand manner, it is not necessary to remove the main unit box from the panel in actual installation work.

- 1** Drill four Ø0.16" (4 mm) holes in the switchboard, wall, etc.
- 2** Fit the main unit on the switch board, wall, etc.
- 3** Fix from the rear of the main unit. Please use the supplied M3 × 0.31" (8 mm) screws.
- 4** Connect the TU2C-LINK cable, AC adapter, and LAN cable to the main unit.
- 5** When installation is completed, peel off the transparent film.

3-2. Attaching the Power Adapter

The power adapter can be installed on a flat surface or on a wall. Do not install it in any other orientation. Fix with the attached binding band and double-sided tape.

Installation allowed

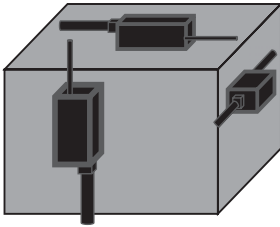

Installation not allowed

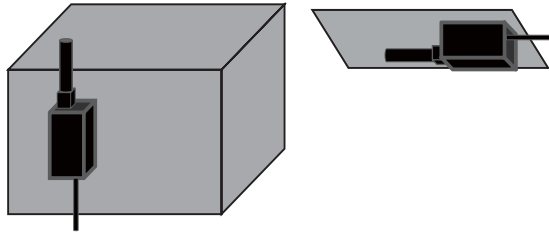

* Install so that the power cable that connects to AC 120 V does not face upward.

REQUIREMENT

Do not install in the following locations.

- Locations with high humidity or water
- Dusty locations
- Locations in direct sunlight and locations subject to high temperatures
- Locations within 3.28 ft (1 m) from televisions or radios
- Outdoors, under awnings, or other locations exposed to rain and dew

3-3. Power, Signal, and Ground Line Connections

Connect the power, signal and ground lines to the specified terminal blocks.

REQUIREMENT

Attach round crimp terminals to all LINK 1, LINK 2, and RS-485 wiring, and tighten the screws securely. After tightening, check that the wiring cannot come out.

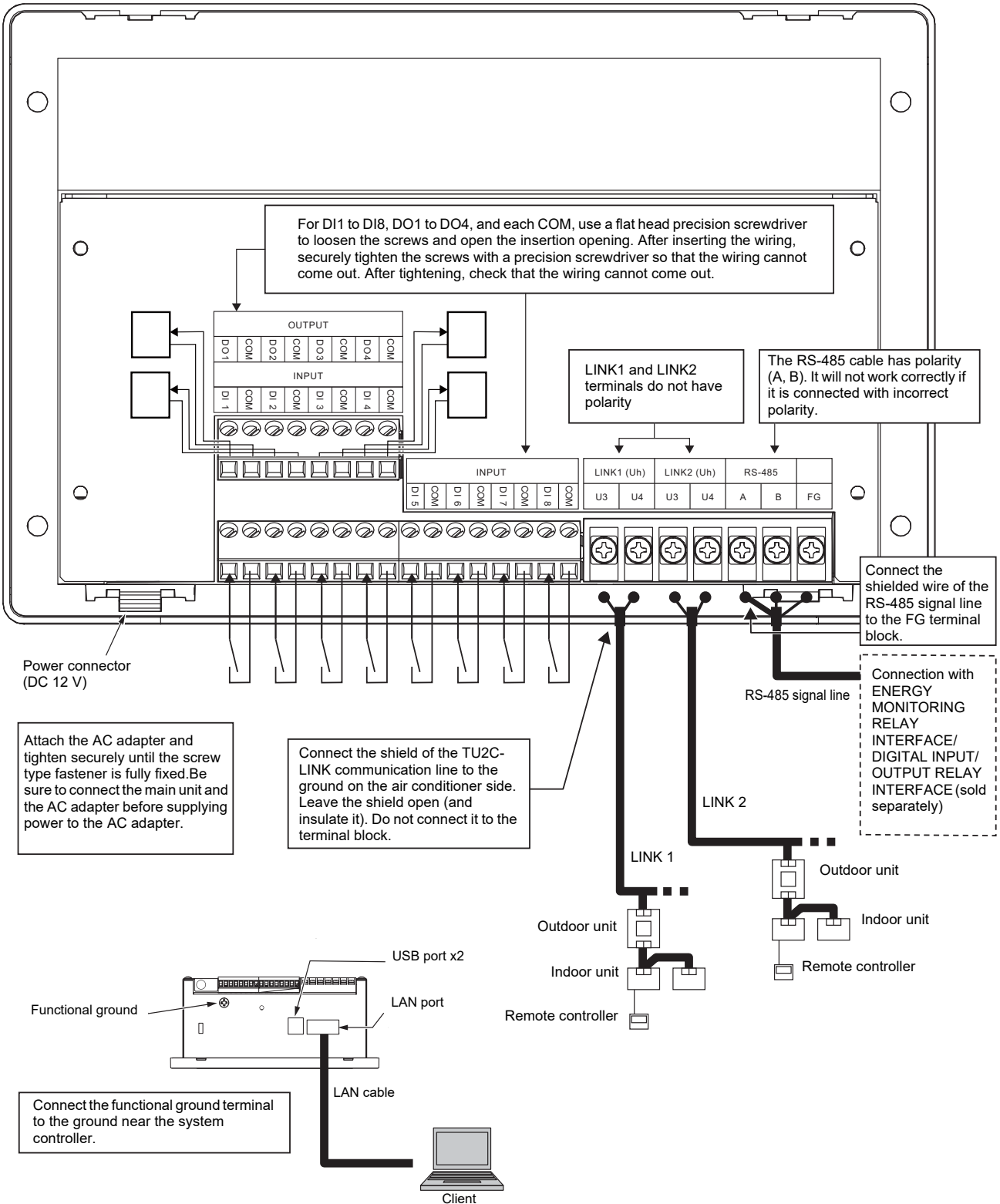

EN

Unit: inch (mm)

TU2C-LINK communication line stripping length

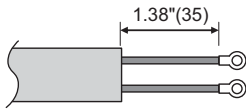

RS-485 cable wire stripping length

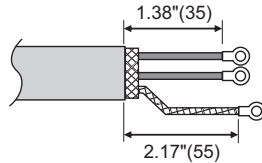

Digital I/O cable stripping length

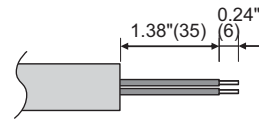

Attach a round crimp terminal to each wire of the power line and signal line.

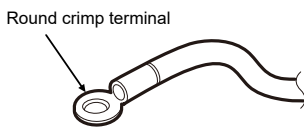

Loosen the screws with a screwdriver, insert the digital I/O cable, and tighten the screws securely.

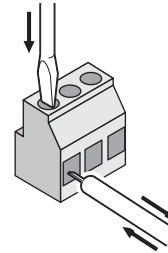

Termination resistance setting

- RS-485 termination resistance settingSet at both ends of the RS-485 communication line. Set one end at the main unit and the other end at the interface. The termination resistance of the main unit is already set as a factory default. Refer to the interface installation manual to set the termination resistance of the interface.
- TU2C-LINK / TCC-LINK termination resistance setting <For TCC-LINK> Leave just 1 line of the termination resistance in the interface board of the outdoor unit (centre unit) ON, and turn all the others OFF. (Refer to the wiring diagram attached to the outdoor unit for the position of SW.) <For TU2C-LINK> For the central control wiring (Uh line), set the termination resistance that is farthest away on the wiring between this central controller and the other unit (VRF, light commercial, air to air heat exchanger, general purpose control interface, air to water heat pump) to ON.

Refer to the manual of each model for the termination resistance setting method.

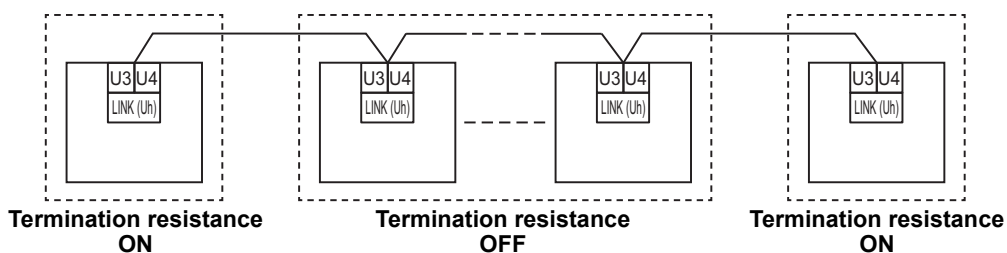

Shield grounding process

- RS-485 cable wire shielded wire Connect to the FG terminal block.
- TU2C-LINK communication line shielded wireWhen using the system controller with one unit, open the shielded wire of the TU2C-LINK communication line and perform insulation processing. When using the system controller with multiple units, connect the shield of the TU2C-LINK communication line to the closed end and open the shield at the final end of the system controller to perform insulation processing. Perform TU2C-LINK communication line shield grounding on the air conditioner side.

REQUIREMENT

- Be sure to install a circuit breaker or all-pole isolating switch (with a contact breaking distance of at least 0.12" (3 mm)) on the primary side of the power supply.
- Fasten the screws to the terminal block with torque of 0.37 lbf • ft (0.5 N•m).

■ Design of Control Wiring

Communication method and model name

The TU2C-LINK model (U series) can be used together with previous models (other than U series).

For details of the model and communication method, see the following table.

Communication method	TU2C-LINK (U series)	TCC-LINK (other than U series)
Outdoor unit	MMY-MUP ^{***} ↑ _____ U series model	Other than on the left (MMY-MAP ^{***} , MCV-MAP ^{***} , etc.)
Indoor unit	MM*-UP ^{***} ↑ _____ U series model	Other than on the left (MM*-AP ^{***} , etc.)
Wired remote controller	RBC-AMSU ^{**} ↑ _____ U series model	Other than on the left
Wireless remote controller receiver	RBC-AXRU ^{**} ↑ _____ U series model TCB-AXRU ^{**} ↑ _____ U series model	Other than on the left
System controller	***_***U ^{**} ↑ _____ U series model	Other than on the left

U series outdoor units: Super Multi u series (MMY-MUP^{***})

Outdoor units other than U series: Super Module Multi i series (MMY-MAP^{***}), etc.

When the connected outdoor unit is Super Multi u series (U series)

Follow the wiring specifications in the table below even when there is a mix of U series and non-U series in the connected indoor units or remote controllers.

Wiring specifications

Item	Communication line
	Central control wiring (Uh line)
Wire diameter	AWG16: Up to 3281 ft (1000 m)
	AWG14: Up to 6560 ft (2000 m)
Wire type	2-core, non-polar
Wire types that can be used	Shielded wire

REQUIREMENT

When wiring the control wiring between indoor and outdoor units (Uv line)/control wiring between outdoor units (Uc line) and the central control wiring (Uh line), use the same wire type and diameter for each line.
Using a mixture of different wire types and diameters may cause a communication error.

System diagram

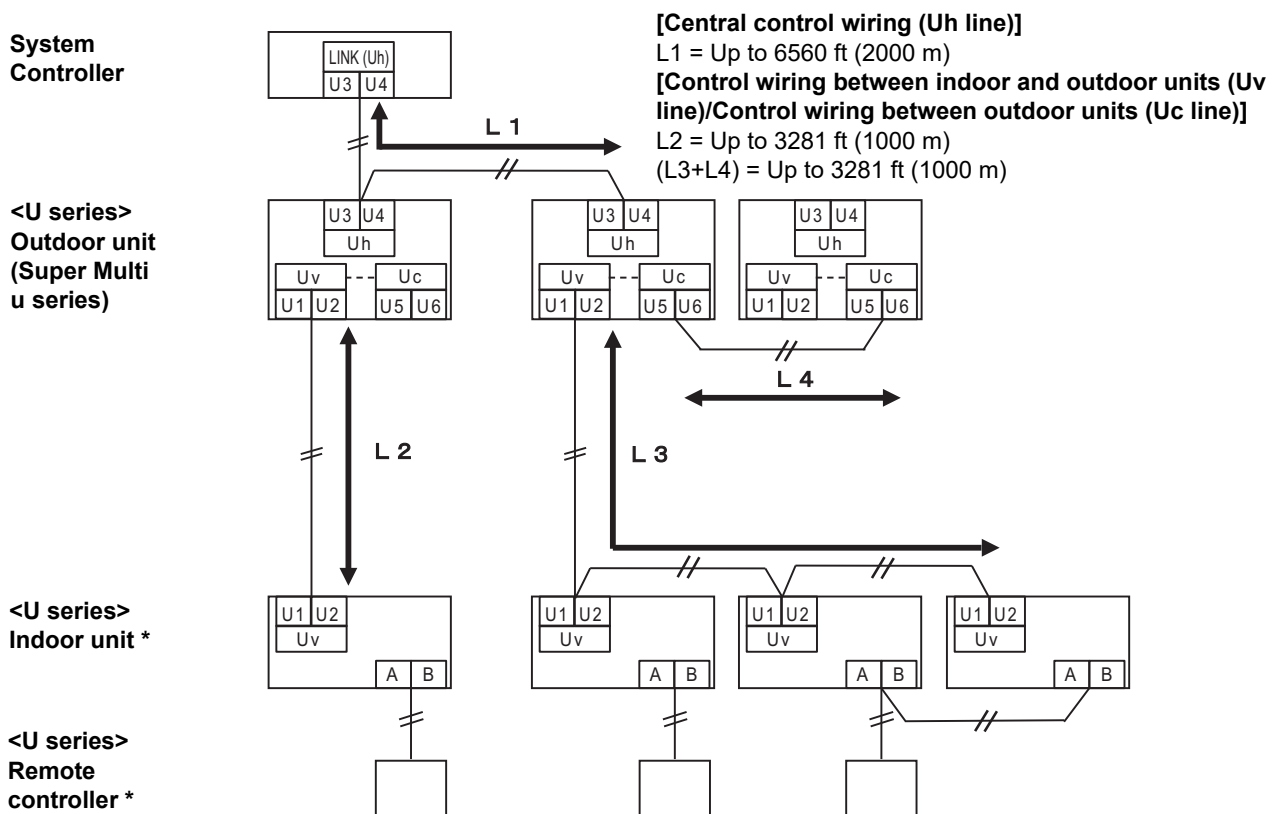

* The wiring specifications in the system diagram above are the same even when the indoor unit or remote controller are other than the U series.

When the connected outdoor units are other than Super Multi u series (U series)

Wiring specifications

Item	Communication line
	Control wiring between indoor and outdoor units and central control wiring
Wire diameter	AWG16: Up to 3281 ft (1000 m)
	AWG14: Up to 6560 ft (2000 m)
Wire type	2-core, non-polar
Wire types that can be used	Shielded wire

REQUIREMENT

When wiring the control wiring between indoor and outdoor units/central control wiring and the control wiring between outdoor units, use the same wire type and diameter for each line.

Using a mixture of different wire types and diameters may cause a communication error.

System diagram

EN

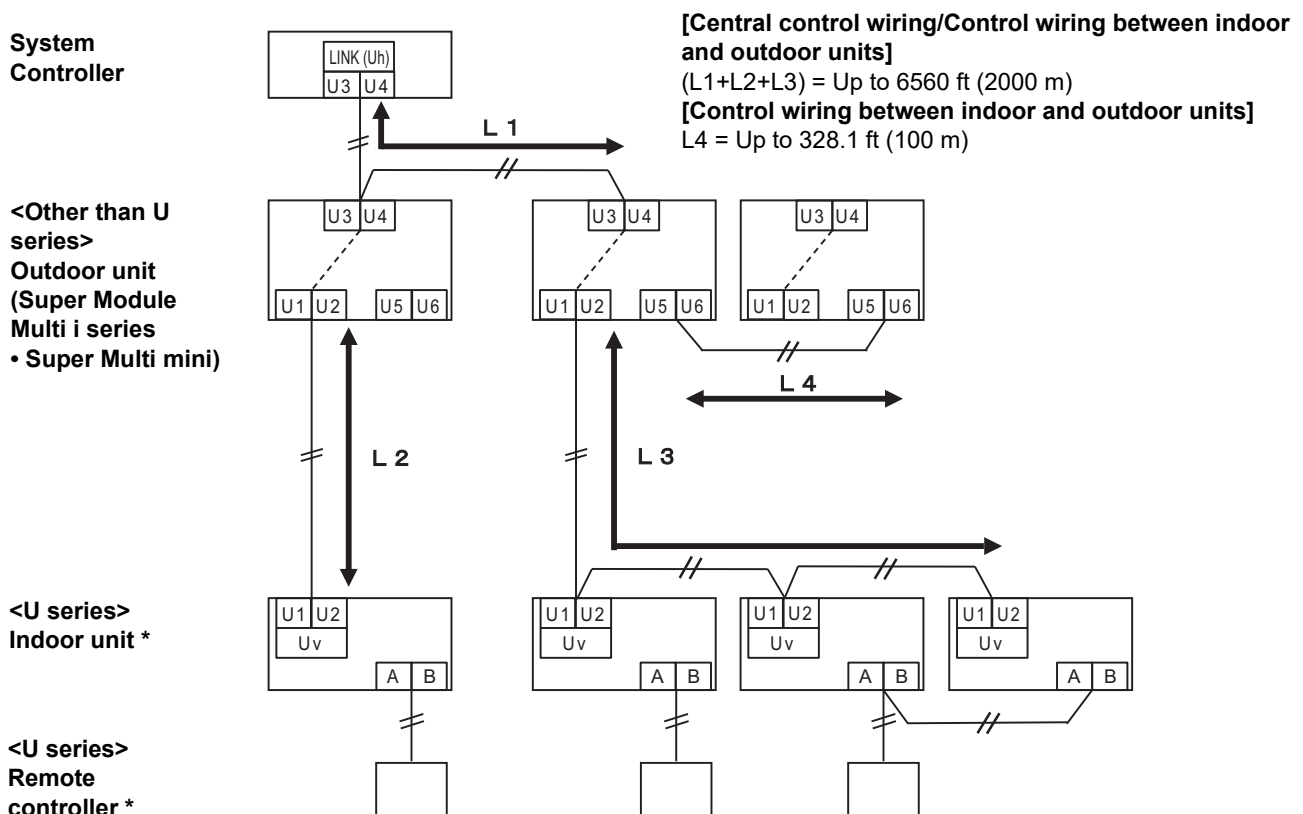

* The wiring specifications in the system diagram above are the same even when the indoor unit or remote controller are other than the U series.

When connecting to a previous model light commercial, air to air heat exchanger, air to water heat pump, or general purpose equipment control interface

Follow the wiring specifications in the table below even when there is a mix of U series and non-U series in the connected indoor units or remote controllers.

Wiring specifications

Item	Communication line
	Central control wiring (Uh line)
Wire diameter	AWG16: Up to 3281 ft (1000 m)
	AWG14: Up to 6560 ft (2000 m)
Wire type	2-core, non-polar
Wire types that can be used	Shielded wire

REQUIREMENT

When wiring the control wiring between indoor and outdoor units (Uv line)/control wiring between outdoor units (Uc line) and the central control wiring (Uh line), use the same wire type and diameter for each line.
Using a mixture of different wire types and diameters may cause a communication error.

System diagram

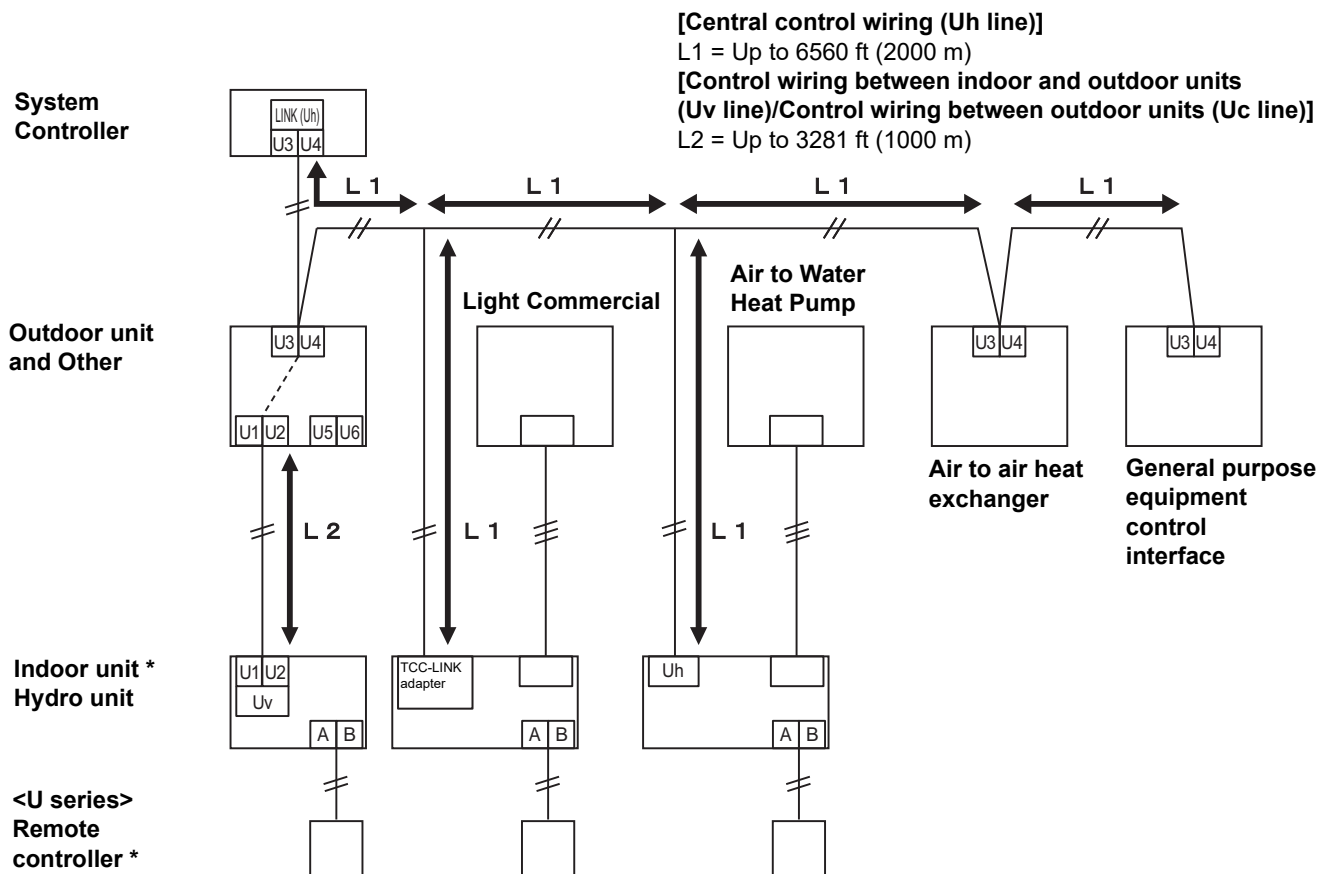

* The wiring specifications in the system diagram above are the same even when the indoor unit or remote controller are other than the U series.

■ Connection to External Devices

Example of connection to external equipment which is connected to digital input/output terminal.

Name	I/O Item	System controller side		External device side	
		I/O conditions	Terminal name	Circuit example	I/O conditions
DO1 Output common	State output	Transistor Open collector output Terminal-to-common allowable voltage / current 24 V DC / 35 mA or less	DO1		Wiring length: Within 328.1 ft (100 m) * If you want to use relays, please refer to page 18.
DO2 Output common			Output common		
DO3 Output common			DO3		
DO4 Output common			Output common		
DI1 Input common	Control input Electric energy pulse				Wiring length: Within 328.1 ft (100 m) <Control input> No-voltage contact A Pulse or static <Electric energy pulse> No-voltage A Pulse Pulse width: 50 msec or more No-voltage contact compatible with a very small current (3 mA or less) DC5 V
DI2 Input common			DI2		
DI3 Input common			DI3		
DI4 Input common			DI4		
DI5 Input common			DI5		
DI6 Input common			DI6		
DI7 Input common			DI7		
DI8 Input common			DI8		

* Wire the cables so that the user does not touch the power supply directly.

* On the external device side, use a basically insulated power circuit and place it in a location where the user cannot touch it.

When using a relay for the circuit on the equipment side of the state output

IMPORTANT

Be sure to connect freewheeling diodes to both ends of the relay coil. (A relay with a built-in diode is recommended.)

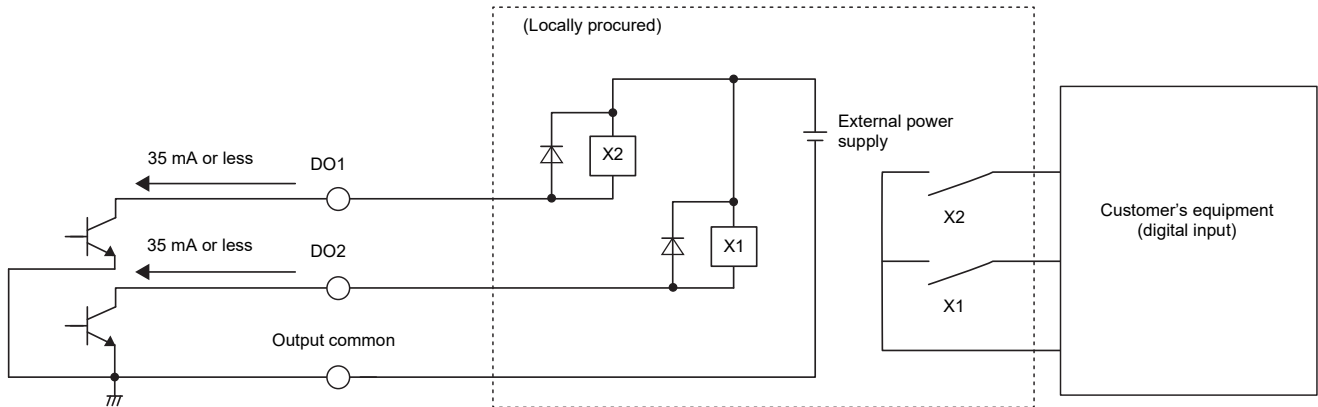

■ Wiring connections

This section shows wiring connection examples with the indoor units, ENERGY MONITORING RELAY INTERFACE, DIGITAL INPUT/OUTPUT RELAY INTERFACE, and remote monitoring PC.

Air conditioning unit group settings

- Indoor units can be set together for each group unit.
- Groups 1 to 64 correspond to the central control addresses 1 to 64 of the indoor units.
- There is a LINK 1 and a LINK 2 for each TU2C-LINK communication line.
If only U Series outdoor units are connected, each line has 128 groups. LINK1 and LINK2 together have 256 groups and 256 zones.
When outdoor units other than the U Series are connected, each line has 64 groups. LINK1 and LINK2 together have 128 groups and 128 zones.
- *When an outdoor unit other than the U series is connected to either line, it is set when an outdoor unit other than the U series is connected on both lines.

Interface connection

Connect the ENERGY MONITORING RELAY INTERFACE and the DIGITAL INPUT/OUTPUT RELAY INTERFACE to the RS-485 cable line. For details of the connection method refer to the interface installation manual.

When using the power meter, connect the power meter separately for each device.

- Multi air conditioners for buildings
- Light Commercial
- Room Air Conditioner (home) (RAC TU2C-LINK I/F connection * For use outside Japan only)
- Air to Water Heat Pump (Hot water supply)
- Air to Water Heat Pump (Air conditioning)
- Air to Water Heat Pump (Air conditioning and Hot water supply)
- General purpose device control interface, External device

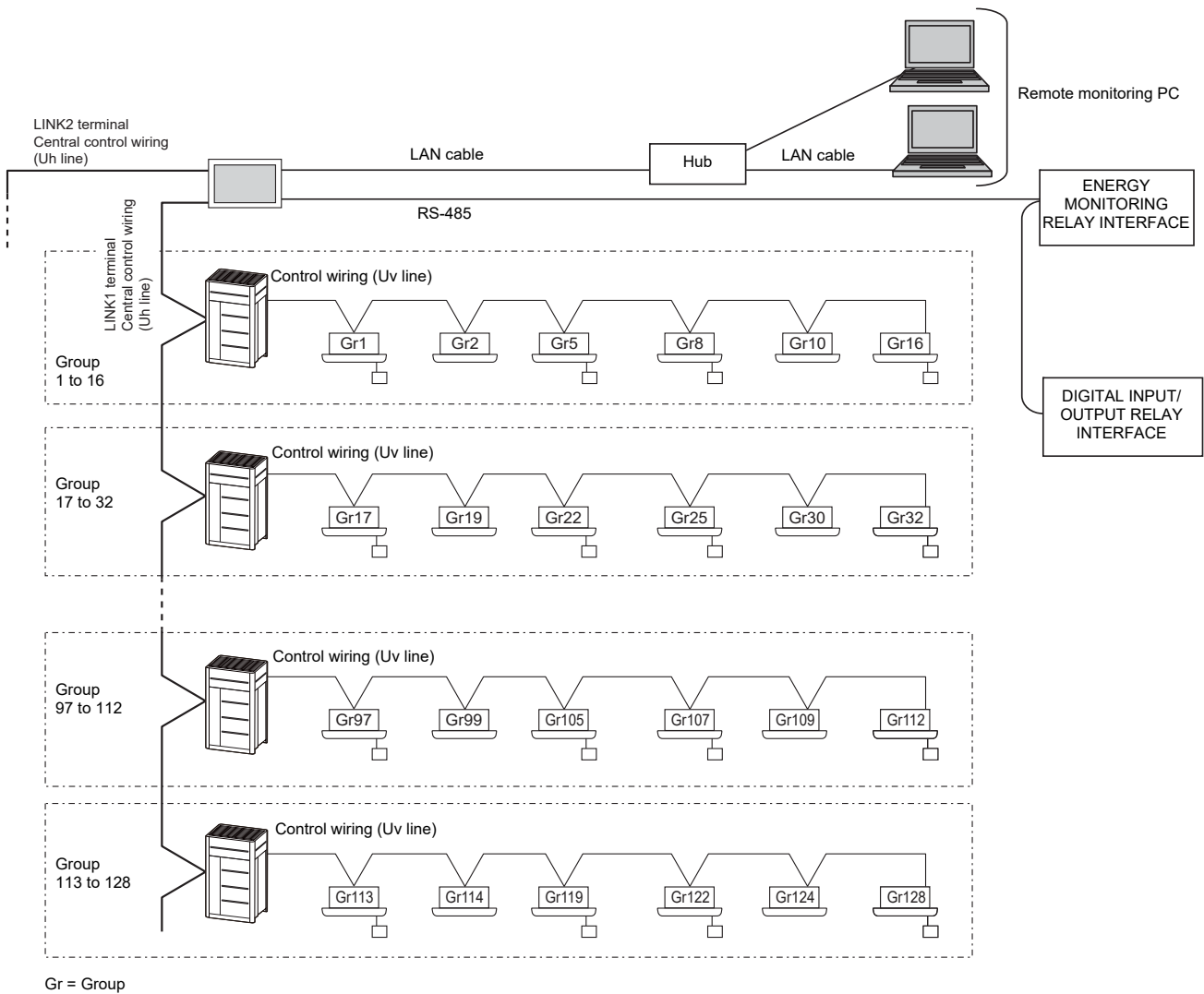

EN

NOTE

When you remove the rear panel of this Unit, there is SW100 which is the termination resistance between LINK1 and LINK2 terminals.
For the central control wiring (Uh line), set the two terminating resistors at both ends of the wiring between this Unit and the air conditioner to ON "Close" as much as possible.

Owner's Manual

For commercial use

Touch screen controller

Model Name

BMS-CT2560U-UL

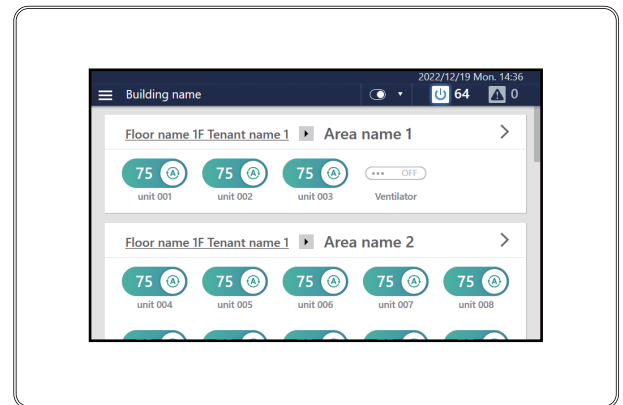

- Thank you for purchasing this System Controller.
- In order to use this product safely and correctly, please read this owner's manual carefully before use and make sure that you fully understand the contents.
- In particular, please be sure to read the "Safety Precautions".
- After reading this manual, be sure to keep it in a place where the operator of the Unit can always view it.

Contents

1 Quick Start Guide	6
2 Safety Precautions	7
3 Operating Method and Screen Structure	9
Touch Panel Operation Method	9
Screen Structure	10
4 Before Usage	11
Air Conditioning System Configurations	11
Glossary	12
Control Target Devices	13
About the Main Screens	14
Home (switch screen)	14
Screen description	14
List screen	17
How to display the screen	17
Screen description	18
Layout screen	20
How to display the screen	20
Screen description	21
Group control screen ([CONTROL] tab)	22
How to display the screen	22
Screen description	23
Individual control screen ([CONTROL] tab)	24
How to display the screen	24
Screen description	25
For the Air to Water Heat Pump (ATW)	27
5 Perform Initial Settings	29
Unit Settings	29
Settings for Remote Monitoring with a PC	30
System diagram	30
Unit settings	30
PC settings	30
Settings	30
Operating environment	30
Install the software	32
Setting when Using Energy Report Software 2	33
Unit settings	33
PC settings	33

6 Basic Usage	34
Start/Stop Operation	34
Overall air conditioning system operation method	34
Group unit operation method	36
Operation method in units of air conditioner or ON/OFF unit	37
Change the Air Conditioning Settings	38
Group unit operation method	38
Air conditioner unit operation method	41
Set the Operation Schedule	44
Screen description	44
Group screen	44
Individual control screen	45
Create a new weekly schedule	46
Create a new special day schedule	48
Monitor the Overall Air Conditioning System	50
7 Various Functions	51
Local Remote Controller Lock	51
Set Operation Details	53
Options for air conditioners	54
Options for Air to Water Heat Pump (ATW)	55
Turn ON/OFF the ventilation function	56
Set ventilation mode	56
Setting the ventilation fan speed	56
Check the output status of the air conditioner(s)	56
Check the outdoor temperature detected by the outdoor unit	57
Set humidification	57
Set the CO ₂ concentration excess setting	57
Make the night operation setting for the outdoor unit	57
Filter sign Reset	58
Set Soft Cooling	58
Control air conditioner power	58
Set saving operation	58
Release thermo OFF	58
Configure and confirm the Return Back settings	59
Monitor power peak cut of outdoor unit	59
Change to energy saving temperature	59
Frost protection	59
Set the temperature change range	60
HiPower	60
ECO	60
Power Select	61
PURE	61
Fireplace	61
Notice Code	61

Check Code (During backup operation)	61
Unit information	62
Auto mode	62
Night set back	62
Hot water boost	62
Anti bacteria	63
ESTIA information	63
Change the Operating Schedule	64
Change the details of the weekly schedule	64
Change the details of the special day schedule	66
Setting items list	68
Delete the operation schedule	71
Confirm the Operation Time	72
Group screen	73
Individual control screen	73
Display the Owner's Manual on the Screen	74
How to display the owner's manual	74
Owner's manual screen description	74
8 Administrator Menu	75
Confirm Check Code History	75
Confirm Notice Code History	75
Confirm the Power Consumption on a Graph	76
Restrict Operation of the Touch screen controller	77
[Functions] Menu Settings	78
How to display the [Functions] menu	78
Release demand control of outdoor unit	78
Set demand control schedule of outdoor unit	79
Add/change power peak cut schedule	79
Delete a power peak cut schedule	81
Restrict operation mode	81
Set the operating schedule or the power peak cut schedule	81
Output data to a USB memory stick	82
Restart the unit	82
Exit the system	82
[Initial setting] Menu Settings	83
How to display the [Initial setting] menu	83
Set the screen display	84
Set the current date and time	84
Set icons of devices other than air conditioners	85
Set the screen theme	85
Set an account for remote operation	86
Add/change user account	86
Delete a user account	87
Set the operation lock level	88
Set the IP address of the Touch screen controller	89

Set check code email destination	90
Change the area set for an indoor unit	91
Set the name of an indoor unit	93
Set the area name	93
Set the screen brightness	94
Set power consumption control conditions	94
9 Remote Monitoring Using a PC	98
Log in to Remote Control Software	98
Log out from Remote Control Software	98
Exit Remote Control Software	99
Configure the login settings for multiple system controllers	100
Log in to multiple system controllers	101
10 Power Distribution	102
Power Distribution System Using the Energy Report Software 2 (PC Software)	102
How to use the power distribution system	103
11 Troubleshooting	104
12 Useful Information	107
13 Appendix	108
Specifications	108
Detailed specifications	108
Function list	109
List by Lock Level/Level	111
14 Warranty and After-Sales Service	113
About the Warranty	113
About After-Sales Service	113
Contact for after-sales service	113
OSS License	114

1 Quick Start Guide

Basic Usage

To start/stop the air conditioner(s)		→ "Start/Stop Operation" (P.34)
To change the set temperature		→ "Change the Air Conditioning Settings" (P.38)
To change the Mode (Cool/Heat/Auto/Dry/Fan)		→ "Change the Air Conditioning Settings" (P.38)
To check whether you have forgotten to turn off the air conditioner(s)	Batch ON/OFF screen	→ "Monitor the Overall Air Conditioning System" (P.50)
To check for current malfunctions	Check code screen	→ "Monitor the Overall Air Conditioning System" (P.50)





Advanced Usage Please use the following functions as necessary.

To set start/stop timer		→ "Set the Operation Schedule" (P.44)
To configure and confirm the energy saving settings	Return Back	→ "Configure and confirm the Return Back settings" (P.59)
	Eco Temperature Shift	→ "Change to energy saving temperature" (P.59)
	Change Temperature Range	→ "Set the temperature change range" (P.60)
	Save Mode	→ "Control air conditioner power" (P.58)
	Schedule settings	→ "Set the Operation Schedule" (P.44)
	Power peak cut schedule	→ "Set demand control schedule of outdoor unit" (P.79)
To operate the Total Heat Exchange Unit		→ "Turn ON/OFF the ventilation function" (P.56)
To cancel the FILTER Sign after filter cleaning		→ "Filter sign Reset" (P.58)
To connect to a PC that has Energy Report Software 2 installed and display the energy usage and power usage report	Connect to a PC that has Energy Report Software 2 installed and display the energy usage	→ "Setting when Using Energy Report Software 2" (P.33)
	IP Address Setting	→ "Set the IP address of the Touch screen controller" (P.89)
	Output to USB memory	→ "Output data to a USB memory stick" (P.82)
	Connect to a PC that has Energy Report Software 2 installed and display the power usage report	→ "Power Distribution System Using the Energy Report Software 2 (PC Software)" (P.102)
To output the daily and monthly report files, the check code files, and the setup files by USB		→ "Output data to a USB memory stick" (P.82)

2 Safety Precautions

This section explains safety precautions you must follow in order to prevent harm to the user and other persons and damage to property.



"Display Description" explains the classification of the degree of harm or damage that may occur if the unit is handled incorrectly, while "Symbol Description" indicates the meanings of symbols.

Display Description	Symbol Description
 WARNING Indicates "Content that is expected to result in death or serious injury (*1) to the user in the case of incorrect handling".	 ⊘ indicates prohibited actions. Specifically prohibited contents are indicated with a picture and/or text in or near the symbol.
 CAUTION Indicates "Content that is expected to result in minor injury (*2) to the user or damage to property (*3) in the case of incorrect handling".	 ● indicates instructions which must be followed. The actual contents of the instructions are indicated with a picture and/or text in or near the symbol.





* 1: Serious injury refers to lasting after effects such as blindness, injury, burns (high temperature / low temperature), electric shock, bone fracture, or poisoning, etc. and injuries that require hospitalization/long-term outpatient treatment.
 * 2: Minor injury refers to injuries, burns, or electric shocks, etc. that do not require hospitalization or long-term outpatient treatment.
 * 3: Damage to property refers to extended damage related to houses, household goods, livestock, or pets, etc.

⚠ WARNING



Installation Precautions

 Request installation Ask the dealer from whom you purchased the unit or a professional for installation work. Installation requires specialised technical expertise. If you attempt to perform installation work yourself and perform the work incorrectly, it may cause fire, electric shock, or injury.	 Use specified products Use a designated TOSHIBA air conditioner. Please use a designated TOSHIBA air conditioner. Using products other than specified may cause fire, electric shock, or water leakage. Also, please ask a professional for installation work.
---	---

Usage Precautions





 Prohibited Do not operate the switches with wet hands. Doing so may cause electric shock or failure.	 Prohibited Do not wet the System Controller. Please be careful not to get the System Controller wet.
 Compulsory Turn off the power if anything is abnormal (burnt odour etc.). Continued use may cause fire or electric shock. Please ask the dealer from whom you purchased the product.	 Compulsory Do not use a power source other than the specified model. Using a power source other than the specified model may cause fire or failure. Please use 220-240 V AC.

Relocation/Repair Precautions



 Prohibited Do not remodel. Doing so may cause fire or electric shock.	 Request Please ask the dealer from whom you purchased the unit for repair. Faulty repair may cause fire or electric shock.
 Request relocation Contact a specialist or the dealer from whom you purchased the unit to relocate and re-install the air conditioner. Faulty installation may cause fire, electric shock or injury.	

⚠ CAUTION

Installation Precautions

 Check the installation location	<p>Do not install in areas with high humidity or vibration. Doing so may cause a failure.</p>	 Check the installation location	<p>Do not install in direct sunlight or near heat sources. Doing so may cause a failure.</p>
 Check the installation location	<p>Do not install in areas where noise is generated. Doing so may cause malfunction.</p>	 Check the installation location	<p>Do not install this product in a place where combustible gas may leak. Gas leaking and accumulating around the product may cause a fire.</p>
 Check the installation location	<p>Do not use this device in locations where children may be present.</p>		

Usage Precautions

 Prohibited	<p>Do not drop the product or apply strong shock. Doing so may cause a failure.</p>	 If anything is abnormal turn off the power	<p>If this product malfunctions, turn off the original power supply, and then contact the dealer from whom you purchased the product to ask for repair. Continued operation with an abnormality may cause fire or electric shock.</p>
 Instructions	<p>When cleaning and checking, turn off the earth leakage breaker. Failing to do so may cause injury.</p>		

Precautions on Connection to External Devices

 Prohibited	<p>Do not connect the System Controller to the Internet. Never connect it. We shall assume no responsibility for any problems arising from the connection. Only a connection to the local area is possible.</p>
---	---

3 Operating Method and Screen Structure

Touch Panel Operation Method

Explains the basic touch panel operation method.

Tap

Touch your finger lightly on the screen and release it immediately.

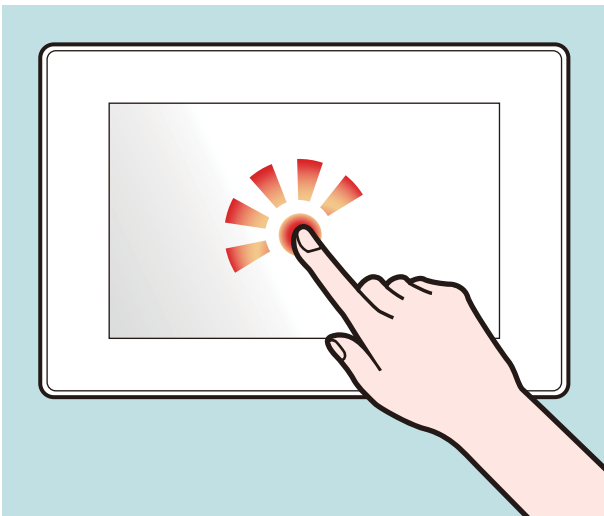

Drag

Tap an object on the screen, hold your finger down, and move.

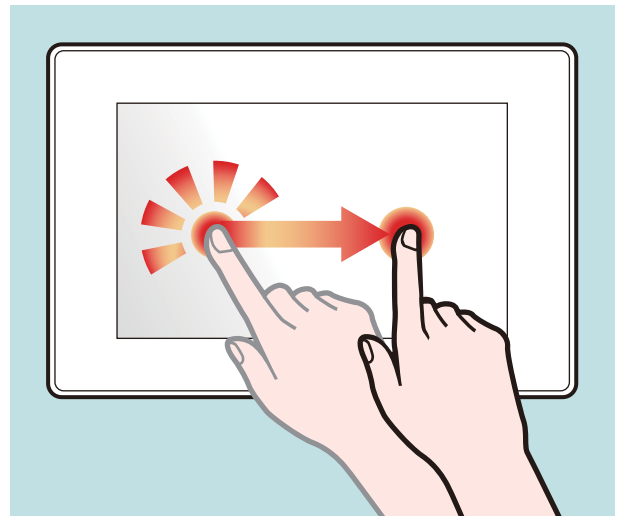

Swipe

Touch your finger lightly on the screen and move it in the desired direction.

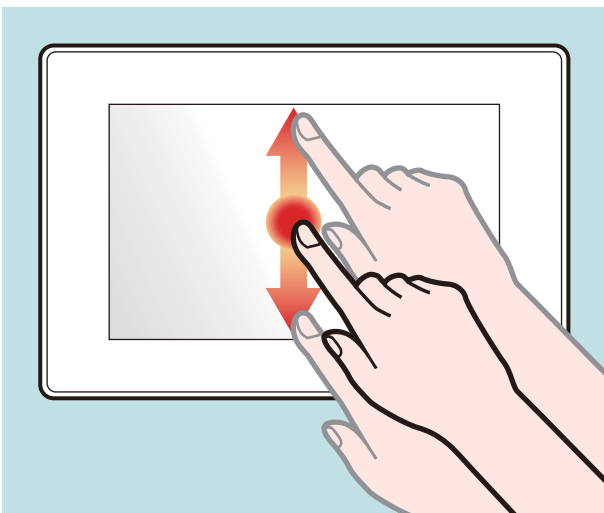

Flick

Touch the screen with your finger and move your finger quickly up, down, to left or the right.

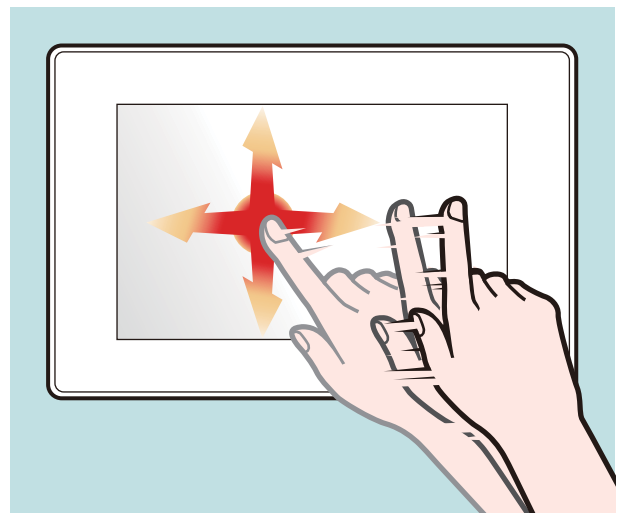

Screen Structure

The main screen structures used by this Unit are as follows. The screen can be switched by tapping (or flicking in some cases).

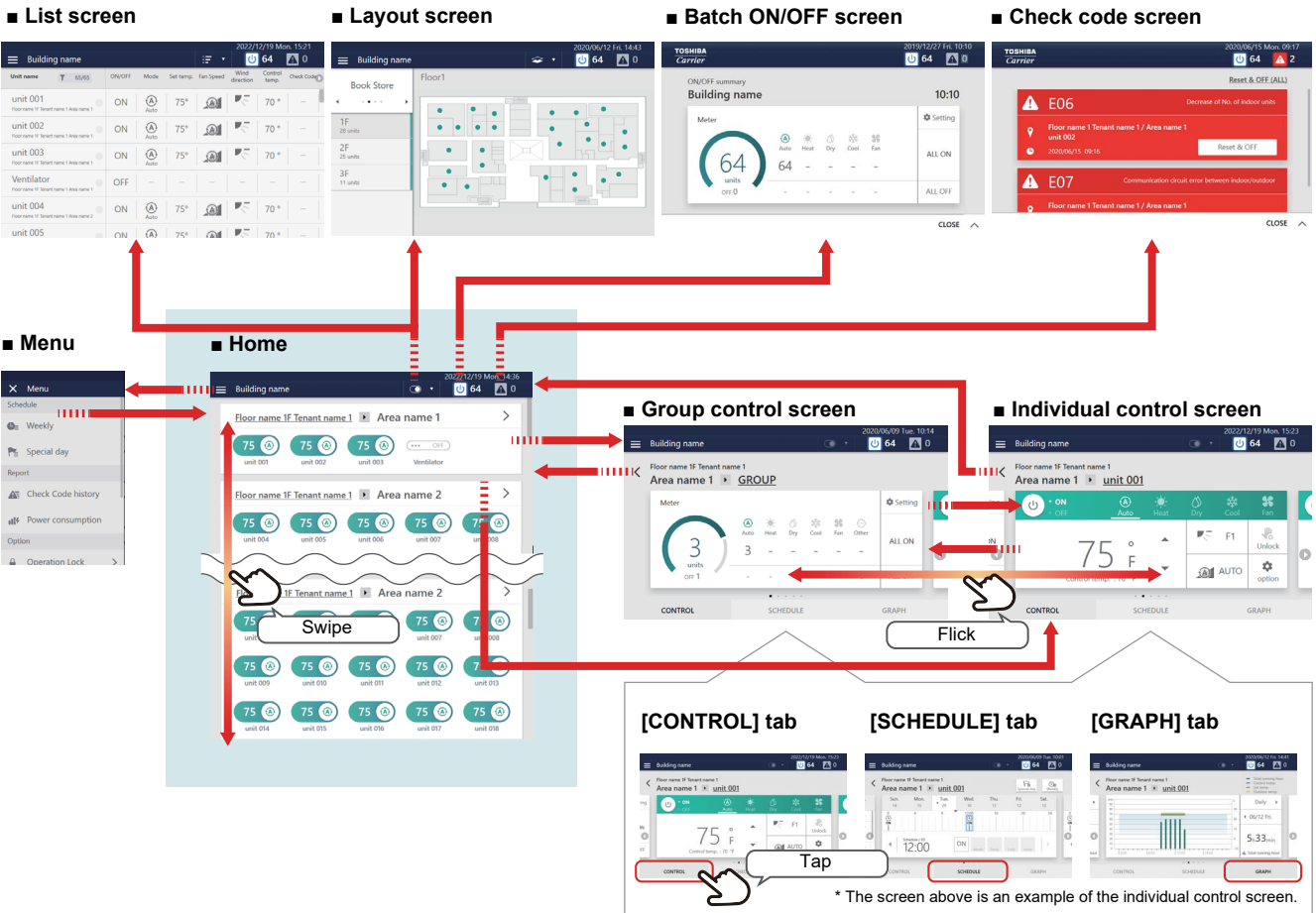

Each screen shows a display example. The display content may vary with the usage environment settings.

Home screen	You can check the operation status of the air conditioner(s) and ON/OFF unit in a list. You can also start/stop individual operation. (P.14)	
List screen	You can check the operation status of the air conditioner(s) and ON/OFF equipment in a list. You can start and stop operation and configure the basic settings. (P.17)	
Layout screen	You can check the operation status of the air conditioner(s) and ON/OFF equipment in a layout. You can also start and stop individual operations. (P.20)	
Group screen	You can check/change the settings in group units. The group screen consists of three tabs: "CONTROL", "SCHEDULE" and "GRAPH". (P.22)	
Individual control screen	You can check/change the settings of the air conditioner(s) and ON/OFF unit individually. The individual control screen consists of three tabs: "CONTROL", "SCHEDULE" and "GRAPH". (P.24)	
Batch ON/OFF screen	You can check the operation status of the whole air conditioning system numerically. You can also start/stop the operation of the whole air conditioning system and configure the detailed settings. (P.50)	
Check code screen	You can confirm check codes that are occurring in the whole air conditioning system in a list. (P.50)	
[CONTROL] tab	You can check the detailed operation status. You can change the settings such as ON/OFF. (P.34)	
[SCHEDULE] tab	You can control the Weekly schedule and the Special day schedule. (P.46)	
[GRAPH] tab	Group screen	You can check the operation time in group units. (P.73)
	Individual control screen	You can check the operation time in air conditioner or ON/OFF unit in units. (P.73)
Menu	You can configure settings for administrators such as screen display change and demand control. (P.75)	

4 Before Usage

Air Conditioning System Configurations

The system configurations that this Unit can control are as follows:

All
Set all air conditioners at once.

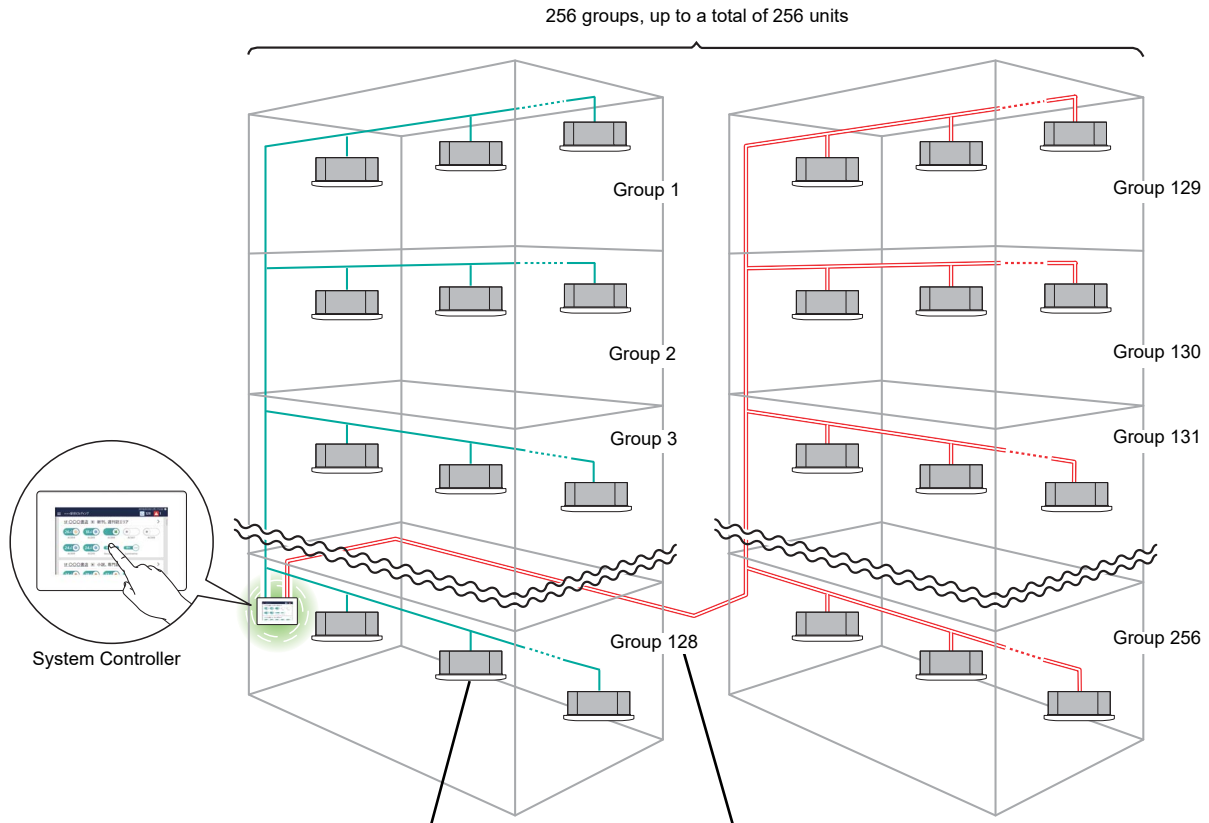

Unit
Set the air conditioners individually.

Group
All air conditioners and ON/OFF unit are divided into 1 to 256 groups, and settings are configured for each group at once.

- There are three units that can be controlled: All, Group, and Unit.
- The maximum number of groups (Floor, Tenant, and Area combinations) that can be controlled is 256.
- The maximum number of units (air conditioners and ON/OFF units) that can be controlled is 256 for air conditioners and 60 for ON/OFF units. *
- * The maximum number of air conditioners may change depending on the model combination.

Glossary

Terminology	Description
Thermo off	When the temperature of a room reaches the set temperature, the outdoor unit compressor stops to switch from cooling/heating to fan operation. Although the indoor unit (air conditioner) is in operation, the outdoor unit repeatedly turns ON/OFF depending on the room temperature.
During power peak cut control	Control to cut the peak of electric power usage.
Flap	A part that changes the air direction at the outlet. It is also called a louver.
Air to Water Heat Pump	This model can control water heating and air conditioning. This model is only available outside the country. It is described as ATW or ESTIA in some parts of the manual.
Room Air Conditioner (home) (RAC)	This is a household air conditioner. It can be connected to a unit via specialized equipment. It is described as RAC in some parts of the manual.
ON/OFF unit	Indicates devices that cannot control or monitor the set temperature or operation mode among the managed devices. Main equipment includes air to air heat exchangers, ventilation fans, etc.
Leak detector (LD)	Refrigerant leak detector This can be displayed on the layout screen for units. If you want to display it, you need to set it in the Section Configuration Software. For details, refer to the manual for the Section Configuration Software. It is described as LD in some parts of the manual.
FS unit	This device controls refrigerant This can be displayed on the layout screen for units. If you want to display it, you need to set it in the Section Configuration Software. For details, refer to the manual for the Section Configuration Software.

Control Target Devices

In this Unit, the following devices can be controlled and monitored.

Names of equipment described in this manual	Equipment	Maximum number of units that can be connected
Air conditioner Can control air conditioning (cooling and heating operations)	Multi air conditioners for buildings (Ceiling cassette, ceiling embedded, ceiling hanging, air to air heat exchanger with coil, etc.)	Total of 256 units
	Light Commercial	
	Package air conditioners for facilities	
	Hot Water Module (* For use outside Japan only)	
	DX-Coil Interface TA type / TF type (* For use outside Japan only)	
	Air to Water Heat Pump (ATW) (* For use outside Japan only)	
ON/OFF unit Can turn operations ON/OFF	Room Air Conditioner (home) (RAC TU2C-LINK I/F connection * For use outside Japan only)	Total of 60 units
	Room Air Conditioner (home) (ON-OFF control interface connection * For use inside Japan only)	
	Air to Air Heat Exchanger	
	General purpose device control interface	
	DX-Coil Interface DDC type (* For use outside Japan only)	
	External device (DI/DO) (Lighting, ventilation fan, etc.)	

● NOTE

The equipment that can be displayed may vary depending on the country or region. For details contact our sales personnel.

About the Main Screens

This section explains the home screen, list screen, layout screen, and the [CONTROL] tabs of the group screen and the individual control screen.

NOTE

Depending on the language settings and the theme settings, the screen languages and display colours differ. The screens shown in the manual use the "English" display setting and the "Type A" theme setting. For details of the display settings, refer to "Set the screen display" (P.84) and for details of the theme settings, refer to "Set the screen theme" (P.85).

Home (switch screen)

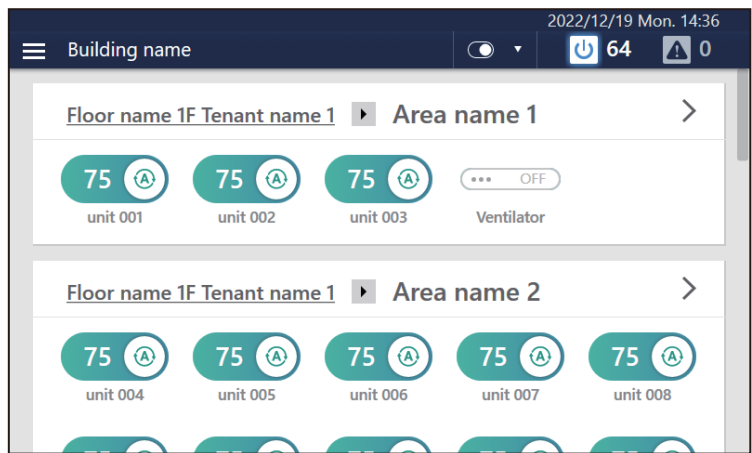





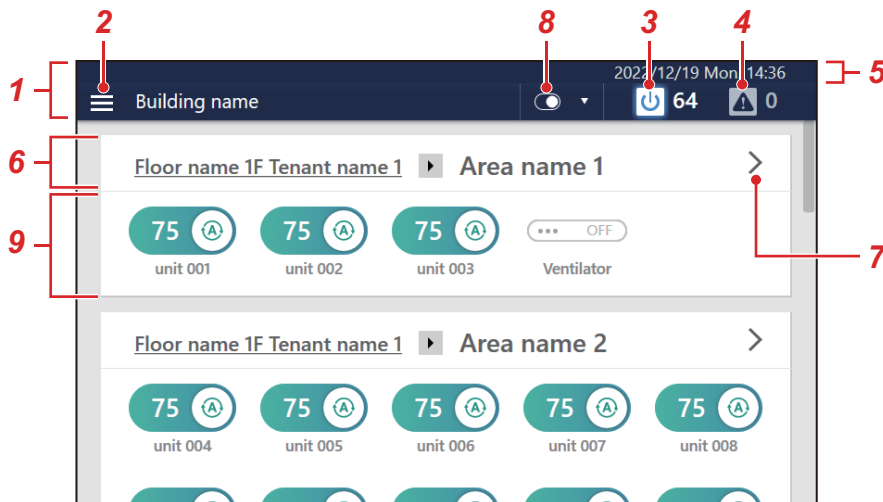

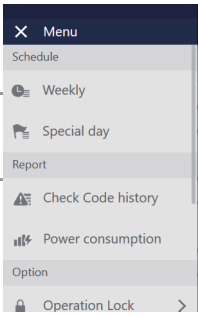
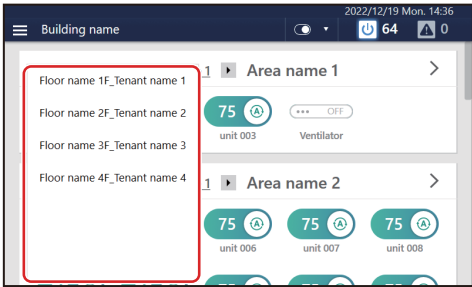

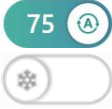









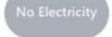

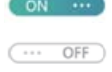



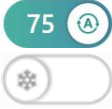









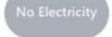

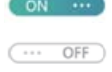



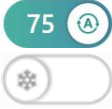





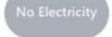

Screen description

Switches for all air conditioners and ON/OFF unit are displayed for each group. You can change the group displayed by scrolling the screen.

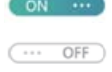

No.	Name (Icon)	Functions										
1	Header area	It is displayed even on screens other than the home screen. The operation content is common to each screen.										
2	Menu button (☰)	<p>Tap to display the menu. You can display various reports and detailed settings for the Unit.</p> <p>NOTE</p> <p>The display content of the menu may partially differ depending on the conditions.</p> 										
3	ON/OFF meter button (⏻/⏿)	Tap to display the batch ON/OFF screen. (P.50) Lights up when there is an air conditioner or ON/OFF unit in operation.										
4	Check Code button (⚠️/⚠️)	Lights up red when a malfunction has been detected. (P.50) Tap to display the check code screen.										
5	Status display section	<p>Displays the current date and time. Also, the following will be displayed depending on the status and settings of the air conditioning system.</p> <table border="1"> <tr> <td></td> <td>Displays when a demand signal is detected.</td> </tr> <tr> <td></td> <td>Displays during demand control of an outdoor unit. (P.79)</td> </tr> <tr> <td></td> <td>Displays when you operate remotely from a computer. (P.98)</td> </tr> <tr> <td></td> <td>Displays while outputting data to a USB memory stick. (P.82)</td> </tr> <tr> <td></td> <td>Displays when the daylight saving time (summer time) setting is ON. (P.84)</td> </tr> </table>		Displays when a demand signal is detected.		Displays during demand control of an outdoor unit. (P.79)		Displays when you operate remotely from a computer. (P.98)		Displays while outputting data to a USB memory stick. (P.82)		Displays when the daylight saving time (summer time) setting is ON. (P.84)
	Displays when a demand signal is detected.											
	Displays during demand control of an outdoor unit. (P.79)											
	Displays when you operate remotely from a computer. (P.98)											
	Displays while outputting data to a USB memory stick. (P.82)											
	Displays when the daylight saving time (summer time) setting is ON. (P.84)											
6	Group name display section	<p>Displays the name of the group that displays the switch (the name of the group to which the displayed switch belongs). Tap the underlined name in the group name to display the drop-down menu. You can jump to other groups.</p> 										
7	FORWARD button (>)	Tap to display the group screen. (P.22)										
8	Screen switching button	Switches the display between the home screen (switch screen), list screen, and layout screen.										

No.	Name (Icon)	Functions																										
9	Switch	<p>The air conditioner or ON/OFF unit switch registered in each group is displayed, and the name is displayed below the switch.</p> <table border="1"> <tr> <td data-bbox="644 349 788 636">  </td> <td data-bbox="788 349 1455 636"> <p>Displays the operation status of the air conditioner(s).</p> <p> means operating state. The set temperature is displayed on the left and the operation mode is displayed on the right. Drag or flick  to the left to stop the operation.</p> <p> is the stopped state. Only the set operation mode is displayed. Drag or flick  to the right to start the operation.</p> <p>Tap the overall switch to switch to the [CONTROL] tab on the individual control screen. (P.24)</p> </td> </tr> <tr> <td data-bbox="644 636 788 779">  </td> <td data-bbox="788 636 1455 779"> <p>This is the switch for the Air to Water Heat Pump (ATW). If the Air to Water Heat Pump (ATW) has an air conditioning function, then the air conditioning can be turned on or off.</p> </td> </tr> <tr> <td data-bbox="644 779 788 869">  </td> <td data-bbox="788 779 1455 869"> <p>This is the switch for the Air to Water Heat Pump (ATW) of just the hot water supply function. This switch cannot be operated.</p> </td> </tr> <tr> <td data-bbox="644 869 788 1012">  </td> <td data-bbox="788 869 1455 1012"> <p>Displays the operating condition of the air conditioner. Operation of the air conditioner(s) is locked. (P.77)</p> </td> </tr> <tr> <td data-bbox="644 1012 788 1128">  </td> <td data-bbox="788 1012 1455 1128"> <p>Shows the operating status of the Air to Water Heat Pump (ATW). Operation of the Air to Water Heat Pump (ATW) is locked. (P.77)</p> </td> </tr> <tr> <td data-bbox="644 1128 788 1218">  </td> <td data-bbox="788 1128 1455 1218"> <p>A malfunction in progress. Tap to switch to the [CONTROL] tab on the individual control screen and check the details of the check code. (P.28)</p> </td> </tr> <tr> <td data-bbox="644 1218 788 1290">  </td> <td data-bbox="788 1218 1455 1290"> <p>Operation is impossible due to power outage (hibernation state).</p> </td> </tr> <tr> <td data-bbox="644 1290 788 1415">  </td> <td data-bbox="788 1290 1455 1415"> <p>Displays the operation status of the ON/OFF unit. Drag  left or right to change the operation status.</p> </td> </tr> <tr> <td data-bbox="644 1415 788 1514">  </td> <td data-bbox="788 1415 1455 1514"> <p>Displays the operation status of the ON/OFF unit. The operation status cannot be changed. The Unit is locked or output control cannot be performed.</p> </td> </tr> <tr> <td data-bbox="644 1514 788 1608">  </td> <td data-bbox="788 1514 1455 1608"> <p>Displayed when the FILTER Sign appears.</p> </td> </tr> <tr> <td data-bbox="644 1608 788 1706">  </td> <td data-bbox="788 1608 1455 1706"> <p>Displayed during operation preparation.</p> </td> </tr> <tr> <td data-bbox="644 1706 788 1805">  </td> <td data-bbox="788 1706 1455 1805"> <p>Displayed during heating preparation.</p> </td> </tr> <tr> <td data-bbox="644 1805 788 1904">  </td> <td data-bbox="788 1805 1455 1904"> <p>Displayed when the output of the air conditioner is limited.</p> </td> </tr> </table>		<p>Displays the operation status of the air conditioner(s).</p> <p> means operating state. The set temperature is displayed on the left and the operation mode is displayed on the right. Drag or flick  to the left to stop the operation.</p> <p> is the stopped state. Only the set operation mode is displayed. Drag or flick  to the right to start the operation.</p> <p>Tap the overall switch to switch to the [CONTROL] tab on the individual control screen. (P.24)</p>		<p>This is the switch for the Air to Water Heat Pump (ATW). If the Air to Water Heat Pump (ATW) has an air conditioning function, then the air conditioning can be turned on or off.</p>		<p>This is the switch for the Air to Water Heat Pump (ATW) of just the hot water supply function. This switch cannot be operated.</p>		<p>Displays the operating condition of the air conditioner. Operation of the air conditioner(s) is locked. (P.77)</p>		<p>Shows the operating status of the Air to Water Heat Pump (ATW). Operation of the Air to Water Heat Pump (ATW) is locked. (P.77)</p>		<p>A malfunction in progress. Tap to switch to the [CONTROL] tab on the individual control screen and check the details of the check code. (P.28)</p>		<p>Operation is impossible due to power outage (hibernation state).</p>		<p>Displays the operation status of the ON/OFF unit. Drag  left or right to change the operation status.</p>		<p>Displays the operation status of the ON/OFF unit. The operation status cannot be changed. The Unit is locked or output control cannot be performed.</p>		<p>Displayed when the FILTER Sign appears.</p>		<p>Displayed during operation preparation.</p>		<p>Displayed during heating preparation.</p>		<p>Displayed when the output of the air conditioner is limited.</p>
	<p>Displays the operation status of the air conditioner(s).</p> <p> means operating state. The set temperature is displayed on the left and the operation mode is displayed on the right. Drag or flick  to the left to stop the operation.</p> <p> is the stopped state. Only the set operation mode is displayed. Drag or flick  to the right to start the operation.</p> <p>Tap the overall switch to switch to the [CONTROL] tab on the individual control screen. (P.24)</p>																											
	<p>This is the switch for the Air to Water Heat Pump (ATW). If the Air to Water Heat Pump (ATW) has an air conditioning function, then the air conditioning can be turned on or off.</p>																											
	<p>This is the switch for the Air to Water Heat Pump (ATW) of just the hot water supply function. This switch cannot be operated.</p>																											
	<p>Displays the operating condition of the air conditioner. Operation of the air conditioner(s) is locked. (P.77)</p>																											
	<p>Shows the operating status of the Air to Water Heat Pump (ATW). Operation of the Air to Water Heat Pump (ATW) is locked. (P.77)</p>																											
	<p>A malfunction in progress. Tap to switch to the [CONTROL] tab on the individual control screen and check the details of the check code. (P.28)</p>																											
	<p>Operation is impossible due to power outage (hibernation state).</p>																											
	<p>Displays the operation status of the ON/OFF unit. Drag  left or right to change the operation status.</p>																											
	<p>Displays the operation status of the ON/OFF unit. The operation status cannot be changed. The Unit is locked or output control cannot be performed.</p>																											
	<p>Displayed when the FILTER Sign appears.</p>																											
	<p>Displayed during operation preparation.</p>																											
	<p>Displayed during heating preparation.</p>																											
	<p>Displayed when the output of the air conditioner is limited.</p>																											

List screen

Unit name	65/65	ON/OFF	Mode	Set temp.	Fan Speed	Wind direction	Control temp.	Check Code
unit 001 Floor name 1F Tenant name 1 Area name 1		ON	Auto	75°			70°	—
unit 002 Floor name 1F Tenant name 1 Area name 1		ON	Auto	75°			70°	—
unit 003 Floor name 1F Tenant name 1 Area name 1		ON	Auto	75°			70°	—
Ventilator Floor name 1F Tenant name 1 Area name 1		OFF	—	—	—	—	—	—
unit 004 Floor name 1F Tenant name 1 Area name 2		ON	Auto	75°			70°	—
unit 005		ON	Auto	75°			70°	—

How to display the screen

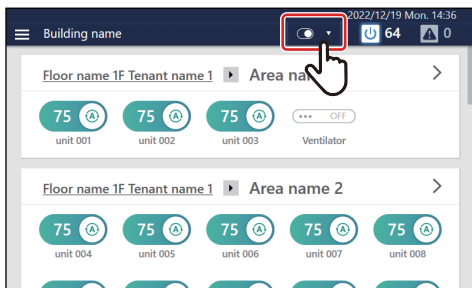

- 1 From the home screen, tap . A pulldown menu appears.

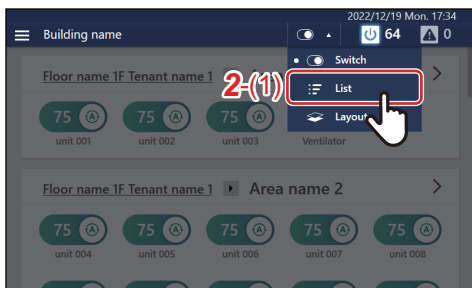

- 2 Tap [2-(1)]. The list screen appears.

Screen description

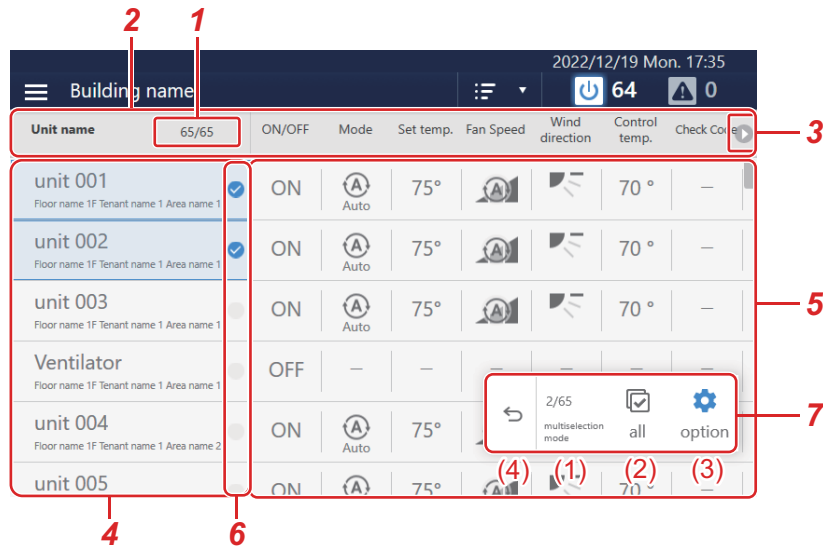

No.	Name (Icon)	Functions
1	Filter button	Tap to display the unit selection screen. You can select the units to display on the unit selection screen.
2	List title	Displays the title of each list. Tap the title to sort the items in ascending order. Tap it again to sort the items in descending order.
3	Display switching button	Moves you to the right page to display the hidden list items.
4	Unit name list	Displays unit names. Under a unit name, group name of that unit is displayed.
5	Unit status list	Displays the status of each unit on a display item-by-display item basis. For an item without a function, a "-" is displayed.
6	Check box for collective setting	Enables you to select a unit subject to collective setting. Each time you tap it, the unit is selected/deselected.
7	Multiselection mode	Displayed if you select the check box for collective setting, so that you can set multiple units. If you tap another check box for collective setting while multiselection mode is displayed, the unit(s) will be added to the units subject to collective setting. (1) multiselection mode: Displays the number of selected units. (2) all: Each time you tap it, all the units in the group are selected or deselected. (3) option: Opens the collective setting change screen. (4) ↩ : Exits multiselection mode.

List of functions shown on the list screen

List display function	
ON/OFF	
Mode	
Set temp.	
Fan Speed	
Wind direction	
Control temp.	
Inspection & Notification	
Lock setting of remote control	ON/OFF
	Mode
	Set temp.
Filter sign reset	
Remote-less	
Preparing	
Power Level	
Energy saving ratio[%]	
Saving operation	
Soft Cooling	
Return Back	
Outdoor temp.	
Night operation	
Power peak cut	
Forced Thermo OFF	
PURE	
Ventilation	ON/OFF
	Mode
	Fan Speed
	24-hour ventilation
	Nighttime heat purge
Control of Temperature Range Setting	Auto
	Heat
	Cool
	Dry

List display function
DHW ON/OFF
Auto mode
Frost protection
Anti bacteria
Night set back
Hot water boost
HiPower
ECO
Power Select
Fireplace
Night operation (RAC)
LD Sensor NG
FS Blocking
FS Out of battery
Stirring operation
Humidity
Humidification setting
CO ₂ concentration
Excessive CO ₂ concentration setting
PM2.5 concentration

Layout screen

NOTE

- This function is displayed only when the layout screen is registered.
- For details on how to configure the layout screen, refer to the Operating Instructions of the Section Configuration Software.

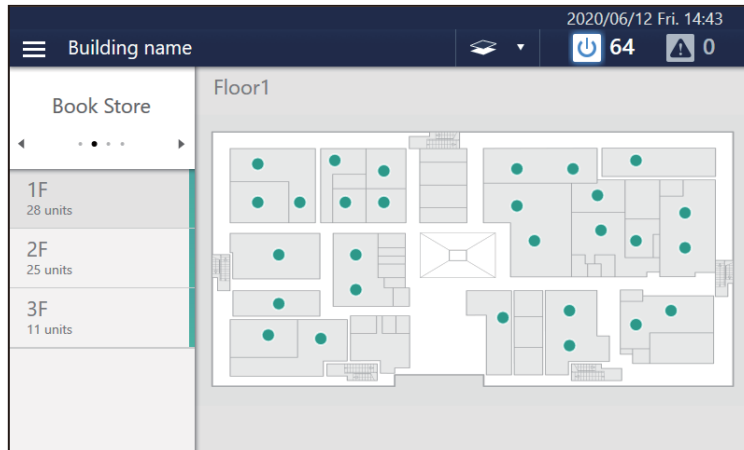

How to display the screen

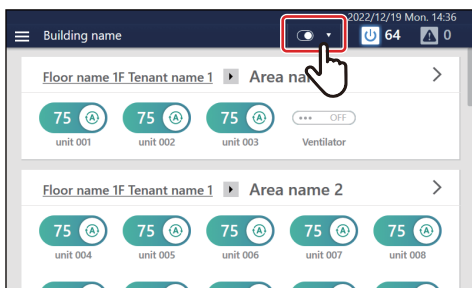

- 1 From the home screen, tap **
A pulldown menu appears.

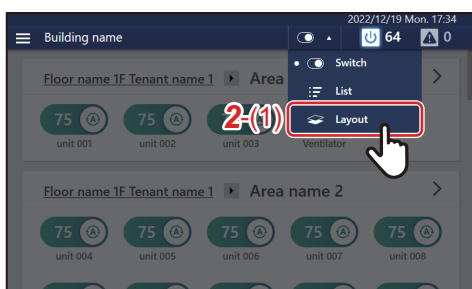

- 2 Tap [2-(1)]**
The layout screen appears.

Screen description

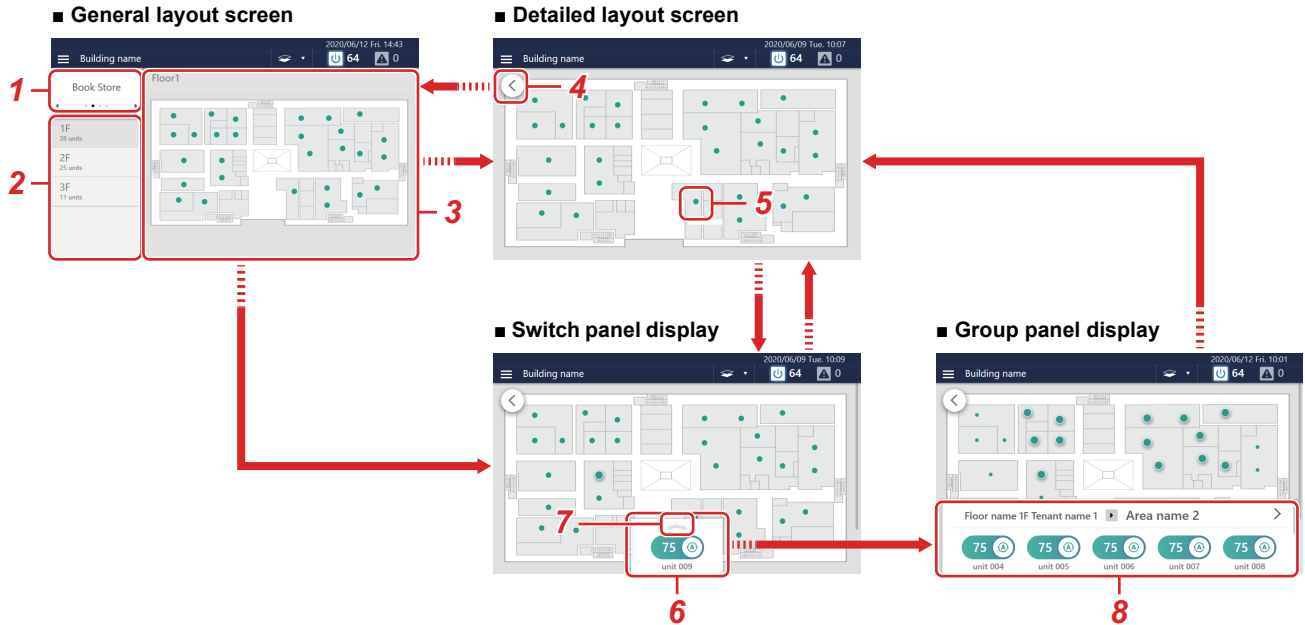

No.	Name (Icon)	Functions																
1	Layer Group Name	By swiping to the right or left in the Layer Group Name, you can change the selected layer.																
2	Level display area	You can select the floor to display in the floor layout. Displays the number of air conditioners installed on each layer. *																
3	Floor layout area	Tap to display the floor layout on the entire screen.																
4	BACK button	Returns you to the general layout screen.																
5	Unit icon	<p>Enables you to confirm the position of a unit on the floor layout.</p> <table border="1"> <thead> <tr> <th>Icon</th> <th>Description</th> </tr> </thead> <tbody> <tr> <td></td> <td>Indicates indoor unit and ON/OFF unit. Tap this icon to display the switch icon.</td> </tr> <tr> <td></td> <td>Indicates the Air to Water Heat Pump (ATW) of the hot water supply function. Tap this icon to display the switch icon.</td> </tr> <tr> <td></td> <td>Indicates the leak detector (LD). Tap this icon to display the status of the leak detector (LD).</td> </tr> <tr> <td></td> <td>Indicates the FS unit. Tap this icon to display the status of the FS unit.</td> </tr> <tr> <td></td> <td>Indicates the CO₂ sensor. Tap this icon to display the CO₂ information.</td> </tr> </tbody> </table> <p>, and can be displayed as connected by wires to . If you want to display the wires, refer to the manual for the Section Configuration Software.</p> <p>The following icon affixed with a figure is displayed if the display setting for the system cooperation defrosting settings is enabled.</p> <p>* For details, contact service personnel.</p> <table border="1"> <thead> <tr> <th>Icon</th> <th>Description</th> </tr> </thead> <tbody> <tr> <td></td> <td>The figure indicates the zone address of the system cooperation defrosting settings. If the figure is underlined, it means that the unit is in the process of preparing for heating. (including defrosting) The display color of the figure indicates the linkage address of the system cooperation defrosting settings, with black being the master unit, green being slave unit 2, and blue being slave unit 3.</td> </tr> </tbody> </table>	Icon	Description		Indicates indoor unit and ON/OFF unit. Tap this icon to display the switch icon.		Indicates the Air to Water Heat Pump (ATW) of the hot water supply function. Tap this icon to display the switch icon.		Indicates the leak detector (LD). Tap this icon to display the status of the leak detector (LD).		Indicates the FS unit. Tap this icon to display the status of the FS unit.		Indicates the CO ₂ sensor. Tap this icon to display the CO ₂ information.	Icon	Description		The figure indicates the zone address of the system cooperation defrosting settings. If the figure is underlined, it means that the unit is in the process of preparing for heating. (including defrosting) The display color of the figure indicates the linkage address of the system cooperation defrosting settings, with black being the master unit, green being slave unit 2, and blue being slave unit 3.
Icon	Description																	
	Indicates indoor unit and ON/OFF unit. Tap this icon to display the switch icon.																	
	Indicates the Air to Water Heat Pump (ATW) of the hot water supply function. Tap this icon to display the switch icon.																	
	Indicates the leak detector (LD). Tap this icon to display the status of the leak detector (LD).																	
	Indicates the FS unit. Tap this icon to display the status of the FS unit.																	
	Indicates the CO ₂ sensor. Tap this icon to display the CO ₂ information.																	
Icon	Description																	
	The figure indicates the zone address of the system cooperation defrosting settings. If the figure is underlined, it means that the unit is in the process of preparing for heating. (including defrosting) The display color of the figure indicates the linkage address of the system cooperation defrosting settings, with black being the master unit, green being slave unit 2, and blue being slave unit 3.																	
6	Selected unit	Displays the operating status of the tapped unit.																
7	Group display button	Tap to display the operating status of the group.																
8	Group display	Displays the operating status of units group by group.																

* Only the Air to Water Heat Pump (ATW) hot water supplies, the number of FS units, LD and CO₂ sensors is not included.

Group control screen ([CONTROL] tab)

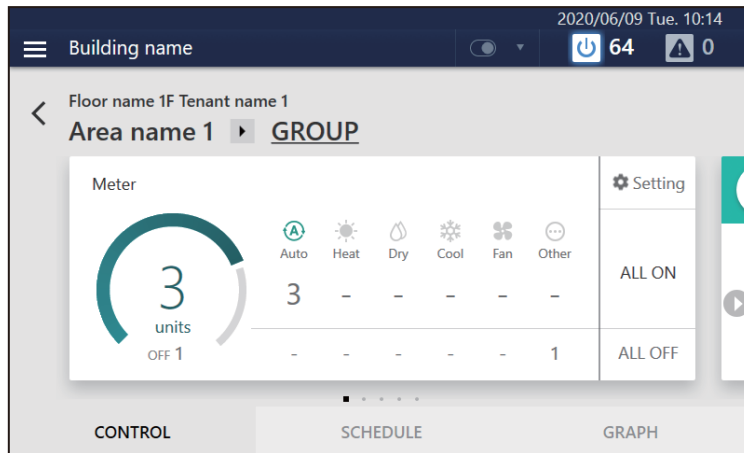

How to display the screen



- 1 Scroll the home screen to display the group you want to change the settings for, then tap >**
The [CONTROL] tab of the group screen is displayed.

Screen description

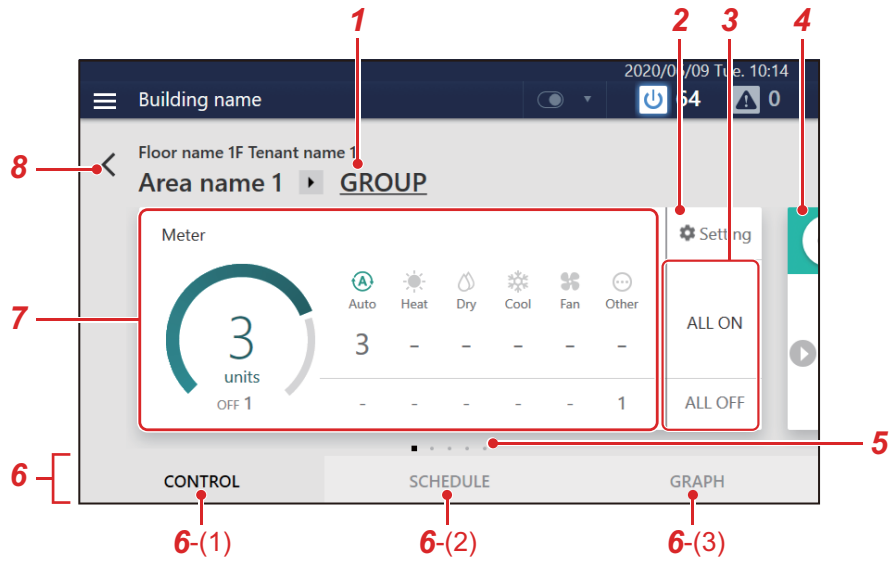

No.	Name (Icon)	Functions
1	Group name	Displays the name of the currently displayed group. Tap to display the drop-down menu. You can switch the display to the individual control screen for another air conditioner or ON/OFF unit registered in the group. <div style="border: 1px solid black; padding: 5px; width: fit-content; margin-left: 20px;"> GROUP unit 001 unit 002 unit 003 Ventilator </div>
2	Setting	You can change overall settings of the group such as Mode, set temperature, air direction, and fan speed simultaneously. (P.38)
3	ALL ON/ALL OFF	You can turn the whole group ON/OFF simultaneously. (P.36)
4	Next screen	Tap to display the individual control screen of the air conditioner or ON/OFF unit registered in the group. You can flick the group screen to display it.
5	Display position	Only the number of air conditioners or ON/OFF unit registered in the group <input type="checkbox"/> is displayed. For the currently displayed screen, <input checked="" type="checkbox"/> is displayed.
6	Switch tab	Tap to switch to the "6-(1)", "6-(2)" or "6-(3)" tab of the group screen.
7	Run	The ON/OFF meter on the left side can be used to check the total number of units operated in the group. On the right side you can check the number of units in each operation mode. The upper row shows the number of units in operation and the lower row shows the number of units stopped. If there are devices that do not have an operation mode, they will be displayed in [Other]. * The number of Air to Water Heat Pumps (ATW) of the hot water supply function is not included.
8	BACK button (<)	Returns to the Home.

Individual control screen ([CONTROL] tab)

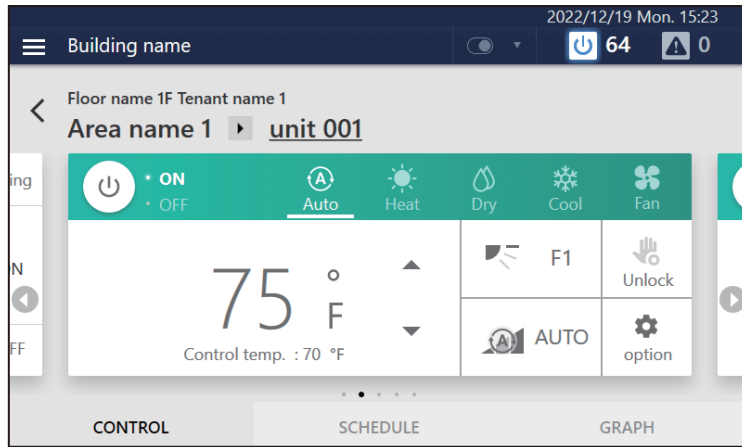

How to display the screen









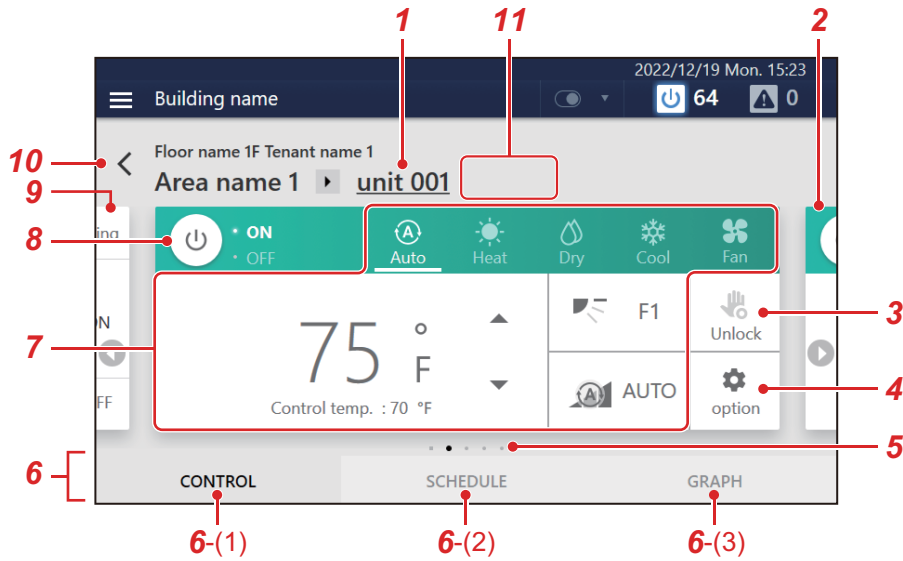

































- 1 Scroll the home screen, display the air conditioner or ON/OFF unit that you want to change the settings for, then tap the switch**

The [CONTROL] tab of the individual control screen is displayed.

Screen description



No.	Name (Icon)	Functions					
1	Unit name	The name of the air conditioner or ON/OFF unit currently displayed is shown. Tap to display the drop-down menu. You can switch the display to the group screen or another air conditioner or ON/OFF unit registered in the group. <table border="1" style="float: right; margin-top: 10px;"> <tr><td>GROUP</td></tr> <tr><td>unit 001</td></tr> <tr><td>unit 002</td></tr> <tr><td>unit 003</td></tr> <tr><td>Ventilator</td></tr> </table>	GROUP	unit 001	unit 002	unit 003	Ventilator
GROUP							
unit 001							
unit 002							
unit 003							
Ventilator							
2	Next screen	Tap to display the individual control screen for other air conditioners or ON/OFF unit registered in the group. You can also flick and display the individual control screen being displayed.					
3	Lock setting of remote control	You can restrict the operating range of the local remote controller of the air conditioner(s) or ON/OFF unit. (P.51) If it is not restricted, [🔓] is displayed. If there are restricted items, [🔒] is displayed.					
4	option	You can set or confirm the details of the operation method. (P.53)					
5	Display position	Only the number of devices registered in the group [] is displayed. For the currently displayed screen, [] is displayed.					
6	SWITCH tab	Tap to switch to the "6-(1)", "6-(2)" or "6-(3)" tab of the individual control screen.					
7	Setting area	You can change basic settings such as operation mode, set temperature, air direction, and fan speed. (P.41)					
8	ON/OFF	Tap to switch between ON/OFF.					
9	Previous screen	Tap to display the individual control screen for other air conditioners or ON/OFF unit registered in the group. You can also flick and display the individual control screen being displayed. The group screen appears at the beginning.					
10	BACK button (<)	Returns to the home screen.					

No.	Name (Icon)	Functions																	
11	Remote-less 	Displays an icon for indoor units that have no local remote control.																	
	(LD) Refrigerant sensor life pre-notification 	This icon is displayed when the end of the operating life of the sensor in the connected leak detector (LD) is approaching. If this icon is displayed, contact your retailer or a service person.																	
	(FS unit) Out of battery 	This icon is displayed when the battery in the FS unit dies. If this icon is displayed, contact your retailer or a service person.																	
	(FS unit) Blocking 	This icon is displayed when the refrigerant in the FS unit is blocked.																	
	Stirring operation 	This icon is displayed when the stirring operation is in progress.																	
	Night operation (VRF, LC, ESTIA) 	This icon is displayed when the night operation setting is enabled.																	
	Ventilation operation 	This icon is displayed when the ventilation fan is in operation.																	
	Ventilation mode	An icon of the ventilation mode in operation is displayed. <table border="1" data-bbox="638 694 1013 851"> <thead> <tr> <th>Icon</th> <th>Ventilation mode</th> </tr> </thead> <tbody> <tr> <td></td> <td>Bypass</td> </tr> <tr> <td></td> <td>Automatic</td> </tr> <tr> <td></td> <td>Heat exchange</td> </tr> </tbody> </table>	Icon	Ventilation mode		Bypass		Automatic		Heat exchange									
	Icon	Ventilation mode																	
		Bypass																	
	Automatic																		
	Heat exchange																		
Ventilation fan speed	An icon of the operating ventilation fan speed is displayed. <table border="1" data-bbox="638 918 1212 1265"> <thead> <tr> <th>Icon</th> <th>Ventilation fan speed</th> </tr> </thead> <tbody> <tr> <td></td> <td>High</td> </tr> <tr> <td></td> <td>Medium</td> </tr> <tr> <td></td> <td>Low</td> </tr> <tr> <td></td> <td>Auto</td> </tr> <tr> <td></td> <td>Unbalance High (exhaust air prioritized)</td> </tr> <tr> <td></td> <td>Unbalance High (supply air prioritized)</td> </tr> <tr> <td></td> <td>Unbalance Medium (exhaust air prioritized)</td> </tr> <tr> <td></td> <td>Unbalance Medium (supply air prioritized)</td> </tr> </tbody> </table>	Icon	Ventilation fan speed		High		Medium		Low		Auto		Unbalance High (exhaust air prioritized)		Unbalance High (supply air prioritized)		Unbalance Medium (exhaust air prioritized)		Unbalance Medium (supply air prioritized)
Icon	Ventilation fan speed																		
	High																		
	Medium																		
	Low																		
	Auto																		
	Unbalance High (exhaust air prioritized)																		
	Unbalance High (supply air prioritized)																		
	Unbalance Medium (exhaust air prioritized)																		
	Unbalance Medium (supply air prioritized)																		
Humidification setting 	This icon is displayed when the humidification setting is set to Auto.																		

For the Air to Water Heat Pump (ATW)

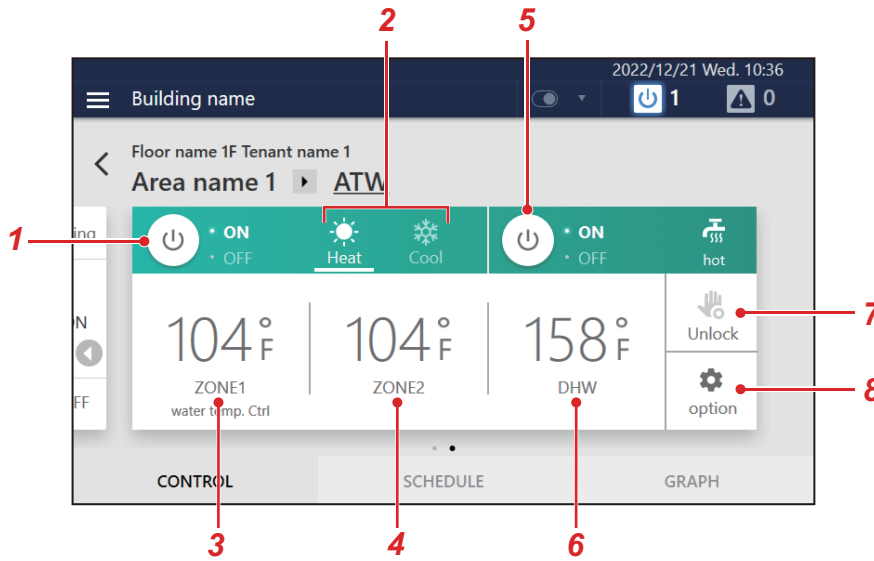

No.	Name (Icon)	Functions
1	Air conditioning ON/OFF icon	Tap to turn the air conditioning on or off.
2	Operation mode	You can change the air conditioner's operation mode. You can only change between heating and cooling.
3	ZONE1 Set temp.	You can change the set temperature of ZONE1.
4	ZONE2 Set temp.	You can change the set temperature of ZONE2.
5	DHW ON/OFF icon	Tap to turn the hot water on or off.
6	Hot water setting temperature	You can change the set temperature of hot water.
7	Lock setting of remote control	You can restrict the operating range of the local remote controller of the air conditioner(s) or ON/OFF unit. (P.51) If it is not restricted, [🔓] is displayed. If there are restricted items, [🔒] is displayed.
8	option	You can set or confirm the details of the operation method. (P.53)

NOTE

This screen is an example display for the Air to Water Heat Pump (ATW). Depending on the connected model, it may not be configurable.

NOTE

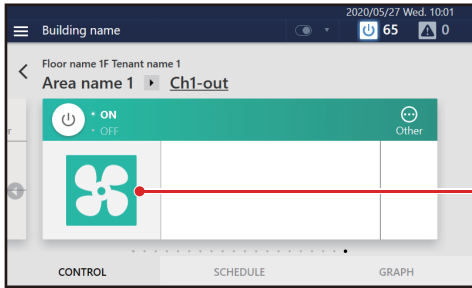

- For ON/OFF unit, only configurable items are displayed.

Icons are displayed only when they are registered. (P.85)

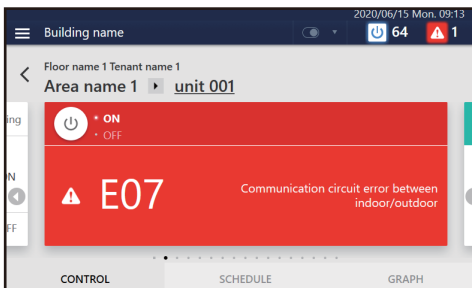

- If a malfunction occurs, a check code is displayed. Operation other than operation ON/OFF is not possible.

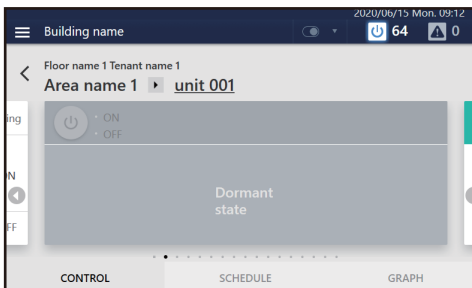

- Operation is impossible due to power outage (hibernation state).

5 Perform Initial Settings

CAUTION

You cannot connect the Unit to the Internet. Never connect it.
To connect to an external device, use a local area connection.

Unit Settings

Have service personnel perform the following work.

1 Check the installation and wiring of the main unit

Follow the installation instructions to complete the installation and wiring work.

2 Check the wiring between the remote controller, indoor unit, and outdoor unit

Check that the address from the remote controller to the Unit is correct, and switch ON/OFF, Cool/Heat and confirm that operation is normal.

3 Create a local setting file with the setting file creation software

Input necessary information based on local air conditioner information and display language settings, etc. into a PC on which the setting file creation software is installed to create a local settings file.

4 Upload the local settings file

Connect the Unit to the PC via LAN and upload the local settings file.
While uploading, the Unit restarts.

5 Confirm the setting contents

Check that the screen display of the Unit is set according to the local settings file, perform ON/OFF, and confirm that the Unit operated on the screen matches the Unit that actually starts to operate.

NOTE

If, after the initial settings, you want to change the names of tenants, groups, or air conditioners from the customer's computer, use "Section Configuration Software" the PC software provided.

You can download the owner's manual and installer for "Section Configuration Software" from inside the controller.

After setting the IP address of the computer (P.31), use the customer's web browser to access the following URL.

<http://192.168.2.80/touchscreencontroller/EN-UJ/download.html>*

* Input the value set in "Set the IP address of the Touch screen controller" (P.89) in place of "192.168.2.80".

Settings for Remote Monitoring with a PC

You can monitor and control the Unit by accessing it from a PC. This section explains the settings for the Unit and the PC. Please see "9. Remote Monitoring Using a PC" (P.98) for the system diagram and the PC operating environment.

NOTE

Some functions cannot be used from a PC. For details, please see "List by Lock Level/Level" (P.111)

System diagram



Unit settings

- 1** Set the user account for remote operation (P.86)
- 2** Set the IP address (P.89)
- 3** Set a destination to send email to when a malfunction occurs (P.90)

PC settings

Settings

IP address/ Subnet mask	Set it to be the same network as the Unit. (Example: the Unit 192.168.2.80/PC 192.168.2.90/subnet 255.255.255.0)
Drive C	Ensure that you have 500 MB or more free space and start up as a user with read/write authority.

Operating environment

The following environment is necessary to use this function.

OS	Windows 10, Windows 11
.NET Framework	4.8
Web browser	Microsoft Edge, Google Chrome latest version

How to set the IP address of the PC

- 1** Display the properties of the network to connect to the System Controller
- 2** Check "Internet Protocol Version 4 (TCP / IPv4)" and click the [Properties] button
- 3** Select "Use the following IP address", set IP address to **192.168.2.***** and Subnet mask to **255.255.255.0**, and click the OK button *

* For "***", enter an address different from that of the System Controller to connect.

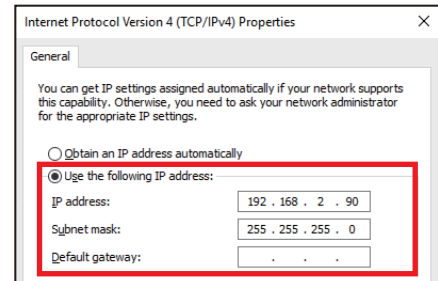
**NOTE**

If your PC is set to use a proxy server, exclude the IP address of the System Controller.

Install the software

- 1** Open the web browser of your PC
- 2** Access "http://[server name or IP address]/touchscreencontroller/[language code]/download.html"

Server name or IP address : Input the IP address that was set in "Set the IP address of the Touch screen controller" (P.89).

Language code: Enter the following value according to the language.

Language	Language Code
English	EN-UL
French	FR-UL
Spanish	ES-UL

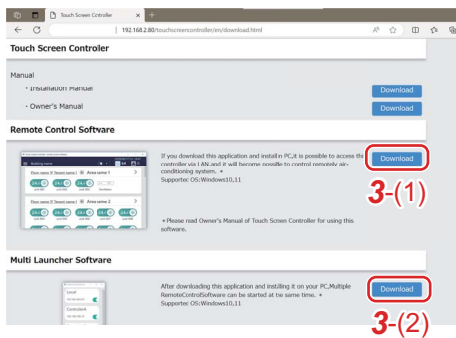

- 3** Click [3-(1)] *
- 4** Save the file according to the browser message
- 5** Double-click on the saved "installer_touchscreencontroller.exe" to unzip/install (setup.exe)

When the installation is completed, a shortcut icon is created on the desktop.



For remote monitoring of multiple system controllers with a PC, click [3-(2)] to similarly install the software.

A shortcut icon is created on the desktop when installation is complete.

NOTE

If .NET Framework 4.8 is not installed on the PC, this software will not work properly. Be sure to download and install .NET Framework 4.8 from the above website.

* About downloading the application

Depending on the browser and other settings, application download may be blocked or not executed due to security and other functions.

Please download selecting "Save" or "Download" from the download option menu.

Setting when Using Energy Report Software 2

By using the Energy Report Software 2, you can display the operation status and operation history of the air conditioners aggregated by this Unit on a PC screen. You can also easily check and output reports (monthly report/daily report) for electric power distribution with a PC. When using the Energy Report Software 2, apply the following settings.

• NOTE

For details on how to use the Energy Report Software 2, refer to the Operating Instructions of the Energy Report Software 2.

Unit settings

- 1 Set the IP address of the Unit (P.89)**

PC settings

- 1 Install the Energy Report Software 2 on the PC**
- 2 Register the target system (this Unit) in the Energy Report Software 2**

6 Basic Usage

This section explains the basic setting method for operation Start/Stop and air conditioning, the setting method for the operation schedule, and the confirmation method for the overall air conditioning system.

Start/Stop Operation

Overall air conditioning system operation method

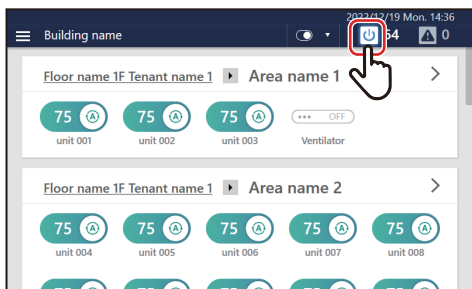

1 Tap  

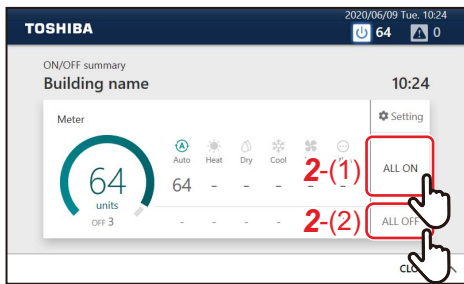

2 Tap [2-(1)] or [2-(2)]

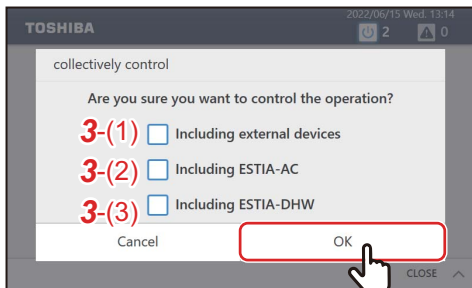

3 Select the equipment to add to be operated, and then tap [3-(4)]

All the air conditioners and the selected equipment start or stop operations.

The selected equipment and air conditioners are added to equipment to be operated. *

No.	Item	Equipment to be added
3-(1)	Including external devices	External device
3-(2)	Including ESTIA-AC	Air to Water Heat Pump (ATW) with air conditioning function
3-(3)	Including ESTIA-DHW	Air to Water Heat Pump (ATW) in hot water supply function

* About selecting confirmation popups

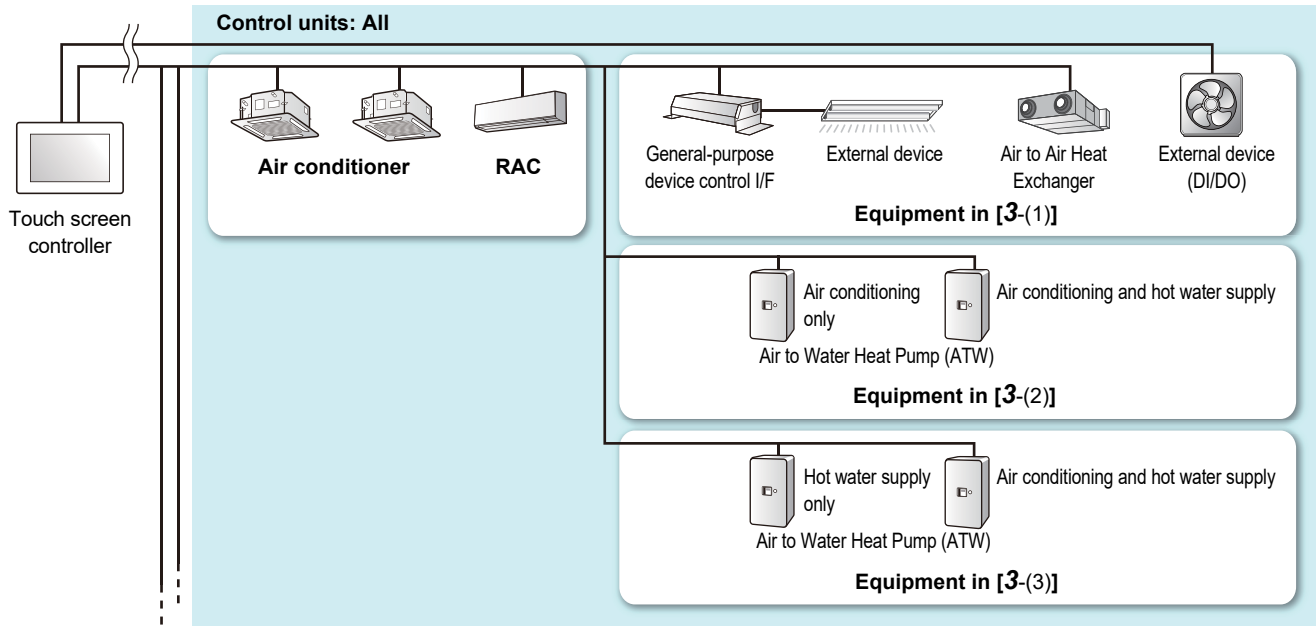

Group unit operation method



1 Scroll the home screen to display the group you want to change the settings for, then tap >

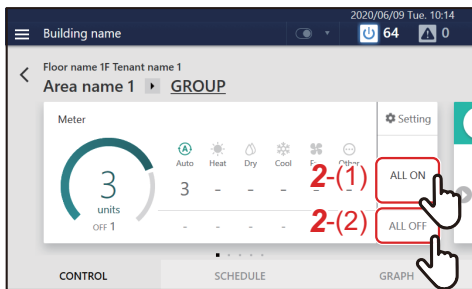

2 Tap [2-(1)] or [2-(2)]

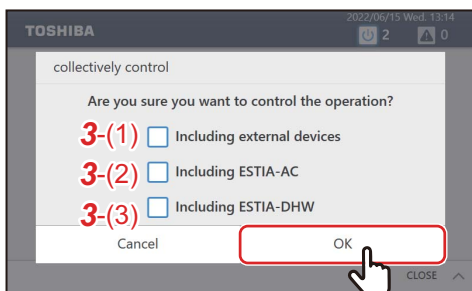

3 Select the equipment to add to be operated, and then tap [3-(4)]

All the air conditioners selected in the group and the selected equipment start or stop operations.

The selected equipment and air conditioners are added to equipment to be operated. *

No.	Item	Equipment to be added
3-(1)	Including external devices	External device
3-(2)	Including ESTIA-AC	Air to Water Heat Pump (ATW) with air conditioning function
3-(3)	Including ESTIA-DHW	Air to Water Heat Pump (ATW) in hot water supply function

* About selecting confirmation popups

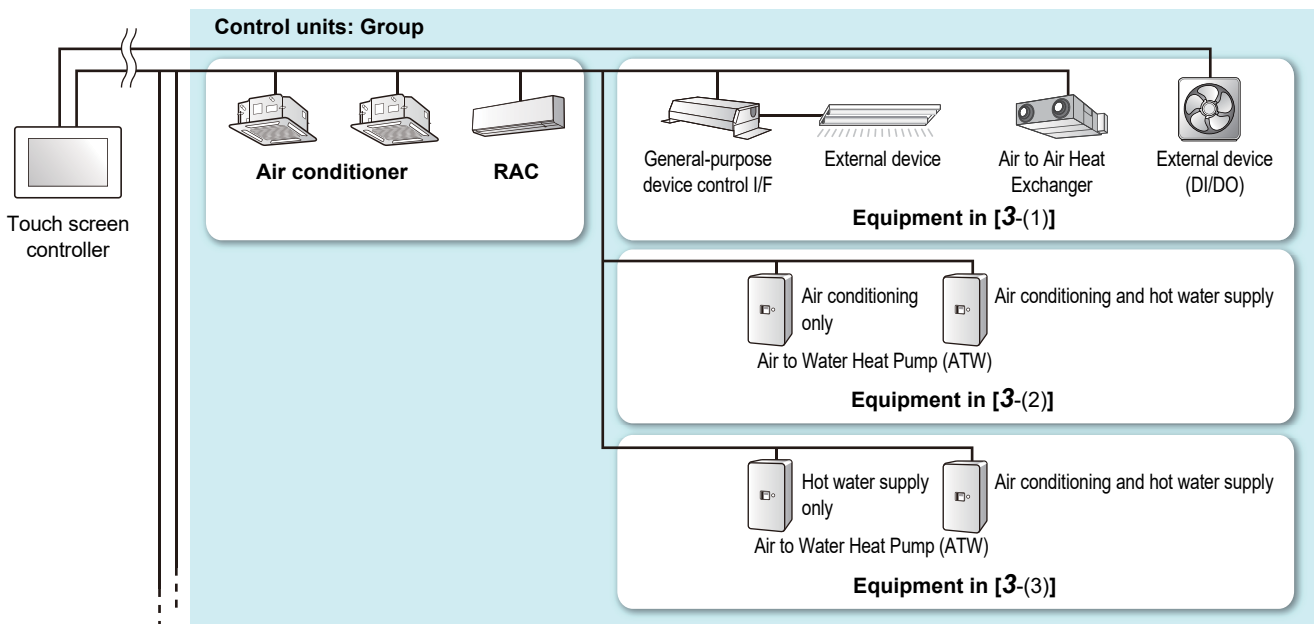

Operation method in units of air conditioner or ON/OFF unit

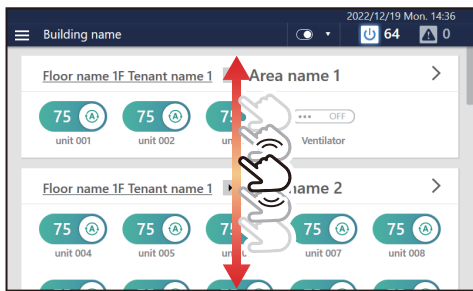

1 Scroll the home screen and display the air conditioner or ON/OFF unit that you want to change the settings for

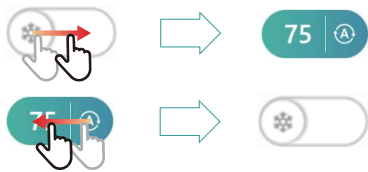

2 Drag or flick the  of the corresponding switch

Drag or flick to the right to start operation.
 Drag or flick to the left to stop operation.

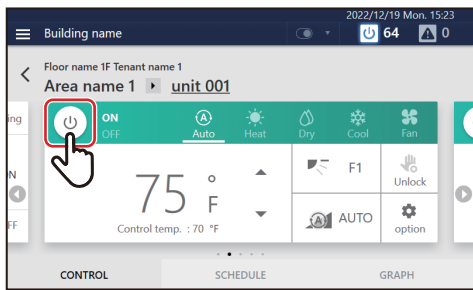

NOTE

You can also start/stop operation by tapping the power icon on the [CONTROL] tab on the individual control screen displayed by tapping the switch.

Change the Air Conditioning Settings

Group unit operation method

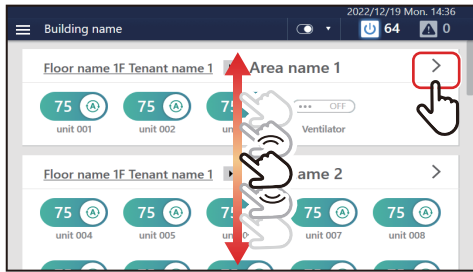

1 Scroll the home screen to display the group you want to change the settings for, then tap >

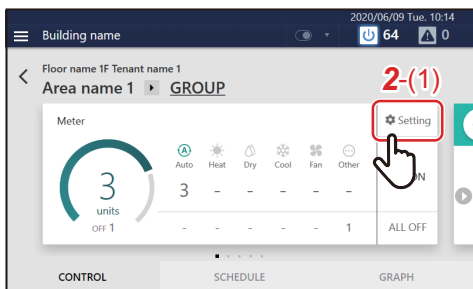

2 Tap [2-(1)]
The batch settings screen is displayed.

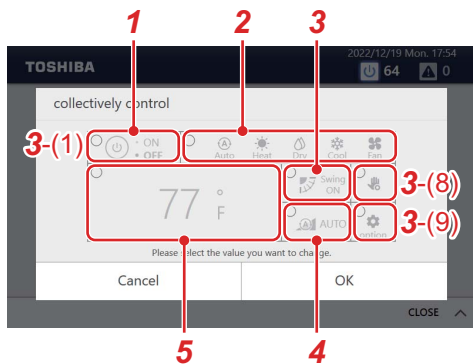

3 Change settings

Example: When changing the operation status settings

3-1 Tap [3-(1)]
The operation status settings screen is displayed.





3-2 Set the check box of [3-(2)] to
You can now change the settings.

3-3 Select [3-(3)] or [3-(4)] and tap [3-(5)]
Return to the batch settings screen.

3-4 Change the other items with reference to steps 3-1 to 3-3
For the setting details, see the following table.

No.	Name	Functions
1	ON/OFF	Can be set to [ON/OFF].
2	Mode	Can be set to [Auto/Heat/Dry/Cool/Fan]. <div style="background-color: #cccccc; padding: 2px;">● NOTE</div> <ul style="list-style-type: none"> A bar is displayed at the bottom of the icon for the currently selected mode. Operation modes that cannot be set are not displayed.

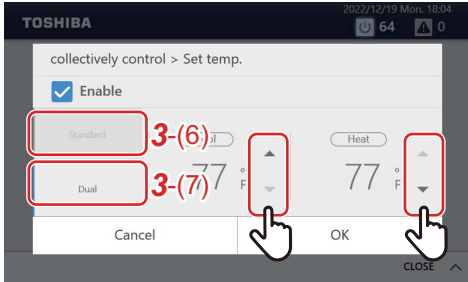
No.	Name	Functions
3	Wind direction	<p>Tap ◀ ▶ to switch to the following.</p>  <p>• NOTE</p> <p>Depending on the connected model, it may not be configurable.</p>
4	Fan Speed	<p>Tap ◀ ▶ to switch to the following.</p>  <p>• NOTE</p> <p>Depending on the connected model, it may not be configurable.</p>
5	Set temp.	<p>Tap ▲ ▼ to change the set temperature.</p> <p>• NOTE</p> <ul style="list-style-type: none"> When set to a temperature outside the setting range limit of each operation mode, the temperature is changed to the upper or lower limit of the setting range. If there are Dual Set Point compatible models in the group, two tabs will be displayed. When you tap [3-(6)], one set temperature is displayed, and when you tap [3-(7)], two set temperatures are displayed. Tap ▲ ▼ to change the set temperature. 

• **NOTE**

- For models that do not have the function set, the setting change is ignored.
- For the setting of [Lock] [Unlock] of [3-(8)], see "Local Remote Controller Lock" (P.51).
- For the [Option] settings of [3-(9)], see "Set Operation Details" (P.53).

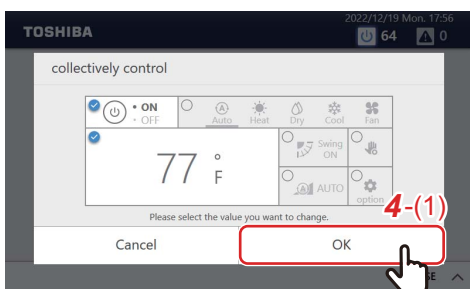

4 Confirm that the changed item is checked, and tap [4-(1)]

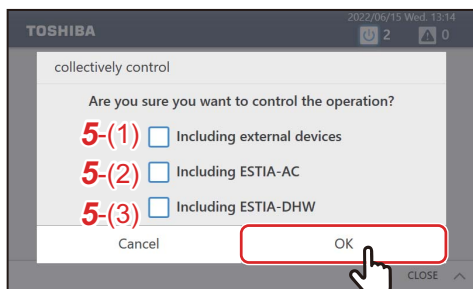

5 Select the equipment to add to be operated, and then tap **[5-(4)]**

All the air conditioners selected in the group and the selected equipment start or stop operations.

The selected equipment and air conditioners are added to equipment to be operated. *

No.	Item	Equipment to be added
5-(1)	Including external devices	External device
5-(2)	Including ESTIA-AC	Air to Water Heat Pump (ATW) with air conditioning function
5-(3)	Including ESTIA-DHW	Air to Water Heat Pump (ATW) in hot water supply function

* About selecting confirmation popups

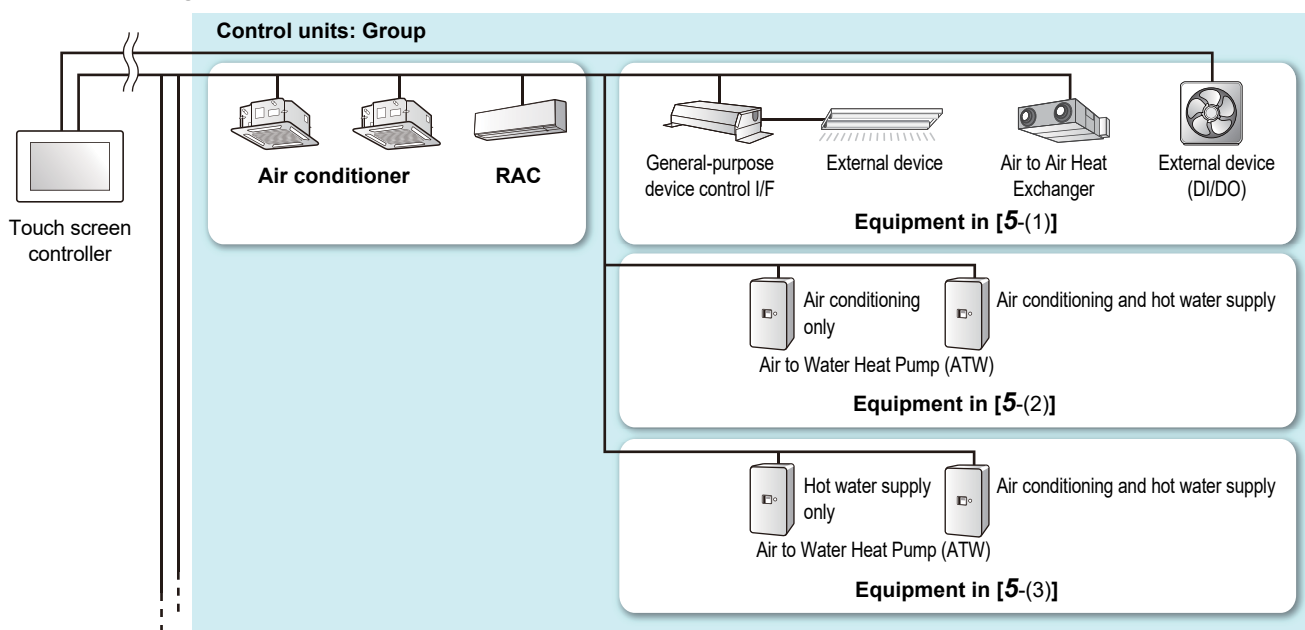

Air conditioner unit operation method

NOTE

To change the settings, it is necessary to set to the operation status. (P.37)

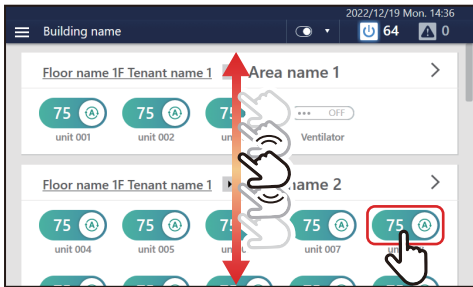

1 Scroll the home screen, display the air conditioner you want to change the settings for, then tap the switch

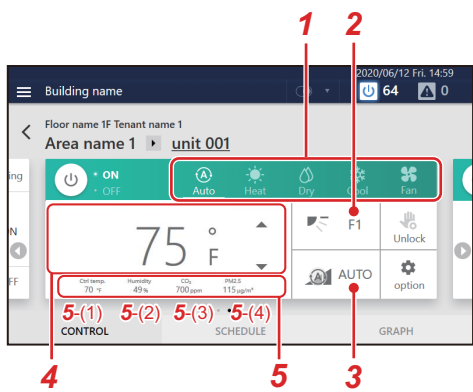

2 Change settings

No.	Name	Functions						
1	Mode	<p>Can be set to [Auto/Heat/Dry/Cool/Fan].</p> <p>NOTE</p> <ul style="list-style-type: none"> A bar is displayed at the bottom of the icon for the currently selected mode. Operation modes that cannot be set are not displayed. 						
2	Wind direction	<p>Tap to switch to the following.</p>  <table border="1" data-bbox="434 1574 1453 1742"> <thead> <tr> <th>Operation Mode</th> <th>Setting Range</th> </tr> </thead> <tbody> <tr> <td>Auto (Cool)/Cool/Dry</td> <td>Swing ON→Swing OFF→F1→F2→F3→Swing ON (Return to the beginning)</td> </tr> <tr> <td>Auto (Heat)/Heat/Fan</td> <td>Swing ON→Swing OFF→F1→F2→F3→F4→F5→Swing ON (Return to the beginning)</td> </tr> </tbody> </table> <p>NOTE</p> <p>Depending on the connected model, it may not be configurable.</p>	Operation Mode	Setting Range	Auto (Cool)/Cool/Dry	Swing ON→Swing OFF→F1→F2→F3→Swing ON (Return to the beginning)	Auto (Heat)/Heat/Fan	Swing ON→Swing OFF→F1→F2→F3→F4→F5→Swing ON (Return to the beginning)
Operation Mode	Setting Range							
Auto (Cool)/Cool/Dry	Swing ON→Swing OFF→F1→F2→F3→Swing ON (Return to the beginning)							
Auto (Heat)/Heat/Fan	Swing ON→Swing OFF→F1→F2→F3→F4→F5→Swing ON (Return to the beginning)							

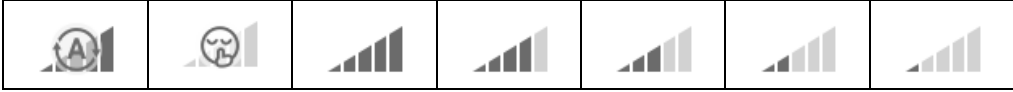
No.	Name	Functions															
3	Fan Speed	<p>Tap to switch to the following.</p>  <p>• NOTE</p> <p>Depending on the connected model, it may not be configurable.</p>															
4	Set temp.	<p>Tap ▲ ▼ to change the set temperature.</p> <p>• NOTE</p> <ul style="list-style-type: none"> • If the operation mode is FAN, the temperature cannot be set. • In this area, icons and text are displayed, such as for frost protection, preparing for operation, or preparing for heating operation. 															
5	Sensor value display	<table border="1"> <thead> <tr> <th>No.</th> <th>Name</th> <th>Functions</th> </tr> </thead> <tbody> <tr> <td>5-(1)</td> <td>Ctrl temp.</td> <td> <p>Indicates the partially compensated temperature inside the room that is detected by the indoor unit.</p> <p>• NOTE</p> <p>The room temperature may differ from the actual temperature depending on the installation location of the indoor unit and other conditions.</p> </td> </tr> <tr> <td>5-(2)</td> <td>Humidity</td> <td>Indicates the humidity detected by the indoor unit.</td> </tr> <tr> <td>5-(3)</td> <td>CO₂</td> <td>Indicates the CO₂ detected by the indoor unit.</td> </tr> <tr> <td>5-(4)</td> <td>PM2.5</td> <td>Indicates PM2.5 detected by the indoor unit.</td> </tr> </tbody> </table> <p>• NOTE</p> <p>Depending on the connected model, it may not be indicated.</p>	No.	Name	Functions	5-(1)	Ctrl temp.	<p>Indicates the partially compensated temperature inside the room that is detected by the indoor unit.</p> <p>• NOTE</p> <p>The room temperature may differ from the actual temperature depending on the installation location of the indoor unit and other conditions.</p>	5-(2)	Humidity	Indicates the humidity detected by the indoor unit.	5-(3)	CO ₂	Indicates the CO ₂ detected by the indoor unit.	5-(4)	PM2.5	Indicates PM2.5 detected by the indoor unit.
No.	Name	Functions															
5-(1)	Ctrl temp.	<p>Indicates the partially compensated temperature inside the room that is detected by the indoor unit.</p> <p>• NOTE</p> <p>The room temperature may differ from the actual temperature depending on the installation location of the indoor unit and other conditions.</p>															
5-(2)	Humidity	Indicates the humidity detected by the indoor unit.															
5-(3)	CO ₂	Indicates the CO ₂ detected by the indoor unit.															
5-(4)	PM2.5	Indicates PM2.5 detected by the indoor unit.															

NOTE

- For the setting of [(1)], see "Local Remote Controller Lock" (P.51).
- For the setting of [(2)], see "Set Operation Details" (P.53).
- If there is no corresponding function, that item is not displayed.

Example of a model without a flap

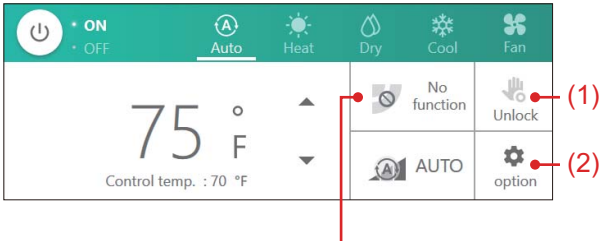

Since you cannot set the air direction, it does not change even if you tap it.

Example of a model where only a certain fan speed can be set

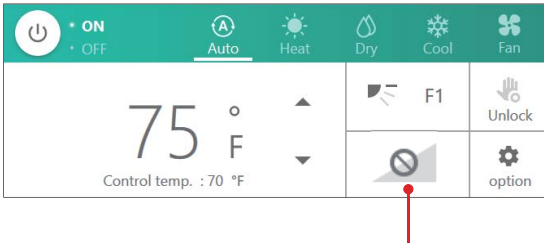

Since you cannot change the fan speed, it does not change even if you tap it.

Example of a case in which the wind direction cannot be changed

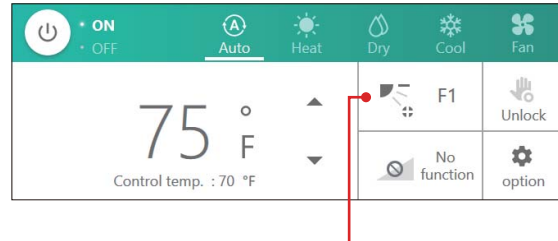

Because the flap is locked, you cannot change the wind direction even if you tap it.

Set the Operation Schedule

You can configure the air conditioners or the ON/OFF unit with a “Weekly schedule”, through which settings such as operation start/stop are changed depending on the specified time for any day from Sunday to Saturday, or a “Special day schedule”, through which settings are changed for special days such as national holidays or special holidays. The operation schedule is set on the [SCHEDULE] tab of the group screen or individual control screen.

NOTE

If a day is set in both the Weekly schedule and the Special day schedule, the Special day schedule applies and the Weekly schedule is disabled for that day.

Screen description

This section explains how to view the [SCHEDULE] tab when setting the operation schedule.

NOTE

Refer to the description of the [CONTROL] tab for the display items that are not explained. (P.22, 24)

Group screen

The schedule set for the air conditioners or ON/OFF unit in the group is displayed in list format in time units.

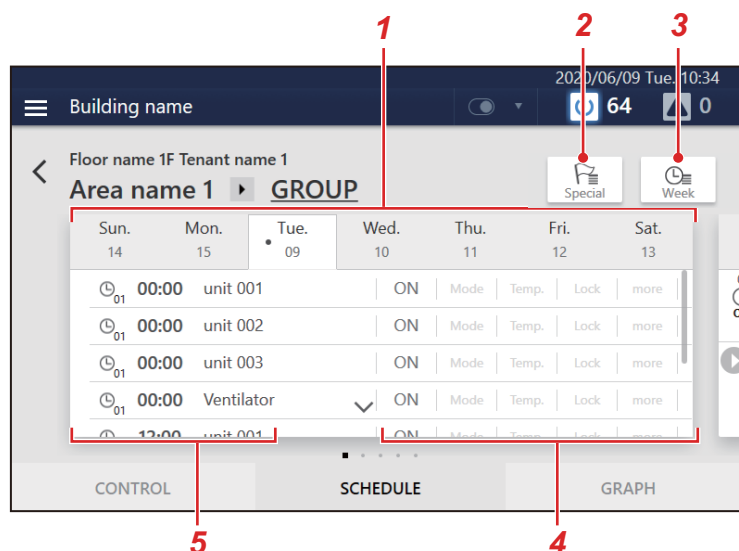

No.	Functions
1	You can switch the display in day-of-week units.
2	Displays the setting screen of Special day schedule.
3	Displays the setting screen of Weekly schedule.
4	The schedule settings content (ON/OFF, Mode, Temp., Lock, more) is displayed.
5	The times when the schedule is executed and the air conditioners and ON/OFF unit for which the schedule is executed are displayed.

Individual control screen

The schedule set for the air conditioner or ON/OFF unit being displayed is displayed on a 24-hour time scale.

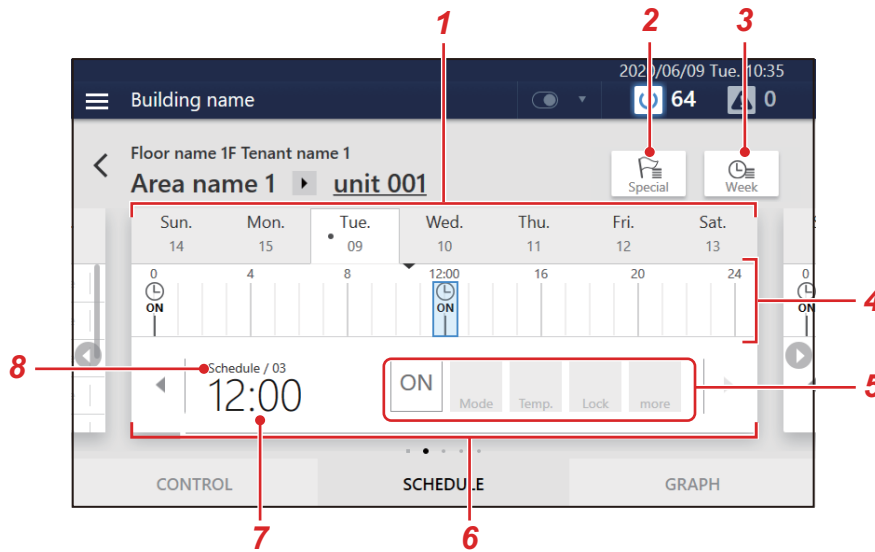

No.	Functions
1	You can switch the display in day-of-week units.
2	Displays the setting screen of Special day schedule.
3	Displays the setting screen of Weekly schedule.
4	🕒 is displayed at the times when the schedule is set. When operation start/stop is set, [ON] or [OFF] is displayed below 🕒. When setting change is set, ⚙️ is displayed below 🕒. Also, the currently displayed schedule is displayed in blue.
5	The schedule settings content (ON/OFF, Mode, Temp., Lock, more) is displayed.
6	You can switch the display to the previous or next schedule.
7	The times when the schedule will be executed are displayed.
8	The schedule setting number is displayed.

Create a new weekly schedule

In a Weekly schedule, you can set:

- Start time
- Day(s) of the week
- Air conditioner(s) or ON/OFF unit
- ON/OFF

Schedule settings can be applied from either the group screen or the individual control screen. In the following procedure, the individual control screen is used to explain.

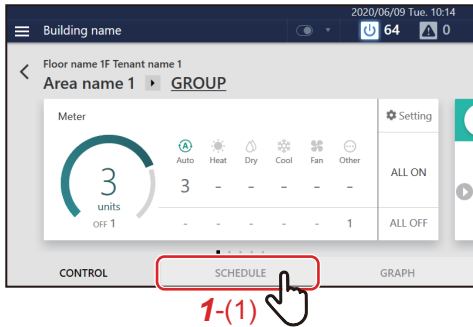

1 Tap [1-(1)] on the group screen or individual control screen

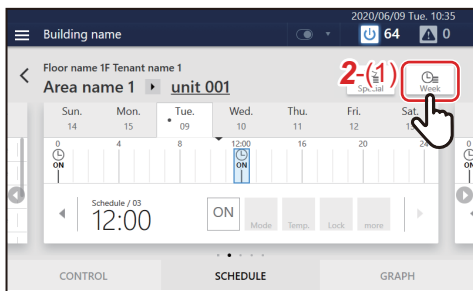

2 Tap [2-(1)]

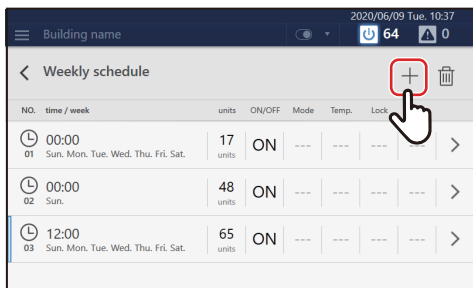

3 Tap +

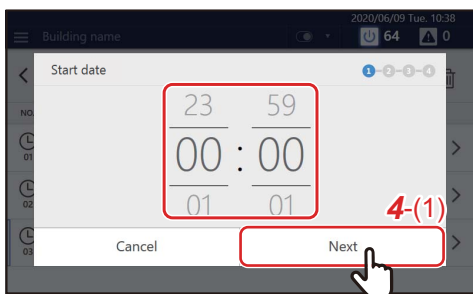

4 Tap or flick to set the start time and tap [4-(1)]

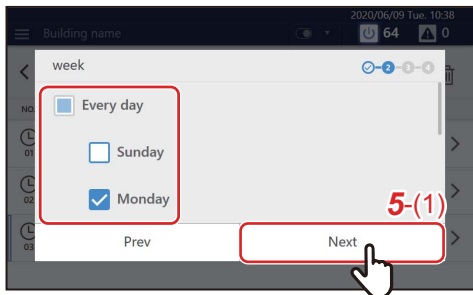

5 Select the day of the week to execute and tap [5-(1)]

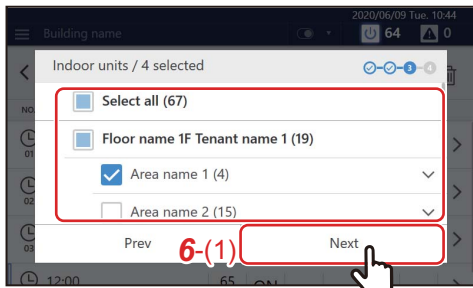

6 Select the air conditioner(s) or ON/OFF unit for setting the schedule and tap [6-(1)]

You cannot select a model that has already been scheduled at the same time.



7 Tap the check box of [7-(1)] and set it to , then select [7-(2)] or [7-(3)] and tap [7-(4)]

You can only set [ON/OFF] here.

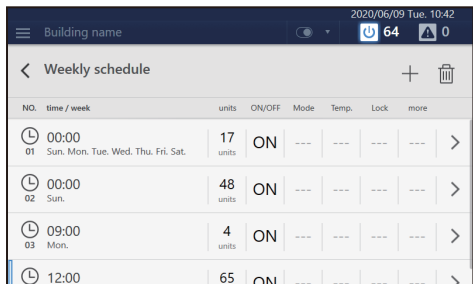

A schedule has been registered.

NOTE

- When setting details such as operation mode or set temperature, etc. as a schedule, refer to "Change the Operating Schedule" (P.64).
- When deleting a registered schedule, refer to "Delete the operation schedule" (P.71).

Create a new special day schedule

In a Special day schedule, you can register special days, such as national holidays and special holidays, to configure a special day schedule that differs from the Weekly schedule.

Schedules can be configured from the group screen or the individual control screen. The following procedure is explained using the individual control screen.

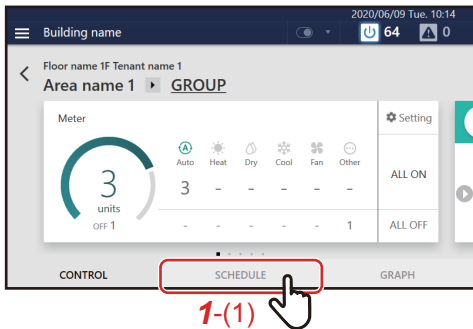

1 Tap [1-(1)] on the group screen or the individual control screen

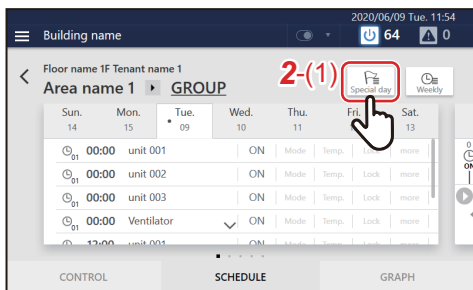

2 Tap [2-(1)]

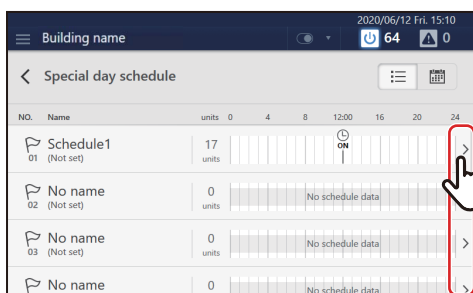

3 Tap >

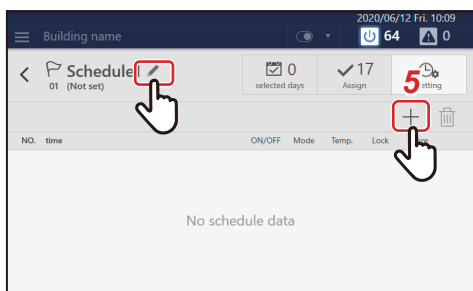

4 Tap and set the schedule name

A keyboard is displayed. Enter the name and then tap [4-(1)].

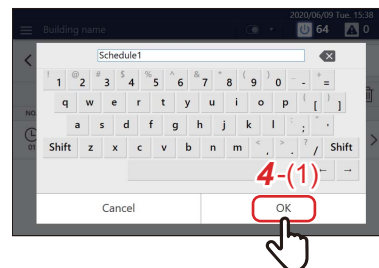

5 Tap to go to step 6

NOTE

- Tap [Shift] to toggle between upper case letters and lower case letters, and numbers and symbols.
- Tap to delete one character.

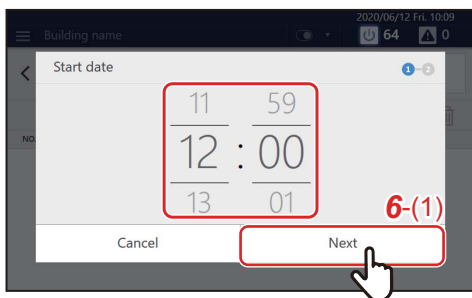

6 Tap or flick to set the start date, and then tap [6-(1)]



7 Tap the check box of [7-(1)] and set it to , then select [7-(2)] or [7-(3)] and tap [7-(4)]
You can only set [ON/OFF] here.

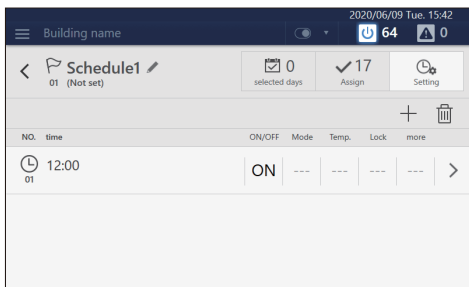

The schedule is registered.

NOTE

- When setting details such as the mode or the set temperature to a schedule, refer to "Change the details of the special day schedule" (P.66)
- When deleting a registered schedule, refer to "Delete the operation schedule" (P.71).

Monitor the Overall Air Conditioning System

To check the operation status of the overall air conditioning system, tap to display the batch ON/OFF screen.
 To check the malfunction occurrence status, tap to display the check code screen.



No.	Functions
1	Displays the overall number of operating units as ON/OFF meters and numerical values. *
2	Displays the number of units for each operation mode. The upper row shows the number of units in operation and the lower row shows the number of units stopped. * If there is ON/OFF unit, it is displayed in [2-(1)].
3	You can change the operation status of the overall air conditioning system. (P.34) For the Option settings, see step 3 on (P.38).
4	Tap to close the batch ON/OFF screen. NOTE You can also tap to close.
5	The check code, check content, notice code, notice content, occurrence location, and occurrence time are displayed.
6	Stop operation of all air conditioners and ON/OFF unit where check codes are displayed and erase the check code (s). NOTE For some ON/OFF unit, only the operation stops, and the check code (s) are not erased.
7	Stop the applicable air conditioner(s) or ON/OFF unit and erase the check code (s). NOTE For some ON/OFF unit, only the operation stops, and the check code (s) are not erased.
8	Tap to close the check code screen. NOTE You can also tap to close.

* The number of Air to Water Heat Pumps (ATW) of the hot water supply function is not included.

7 Various Functions

This section explains detailed settings on the [CONTROL] tab, how to change the schedule on the [SCHEDULE] tab, and how to check the power usage on the [GRAPH] tab.

Local Remote Controller Lock

You can restrict operation of the local remote controllers that belong to each air conditioner.

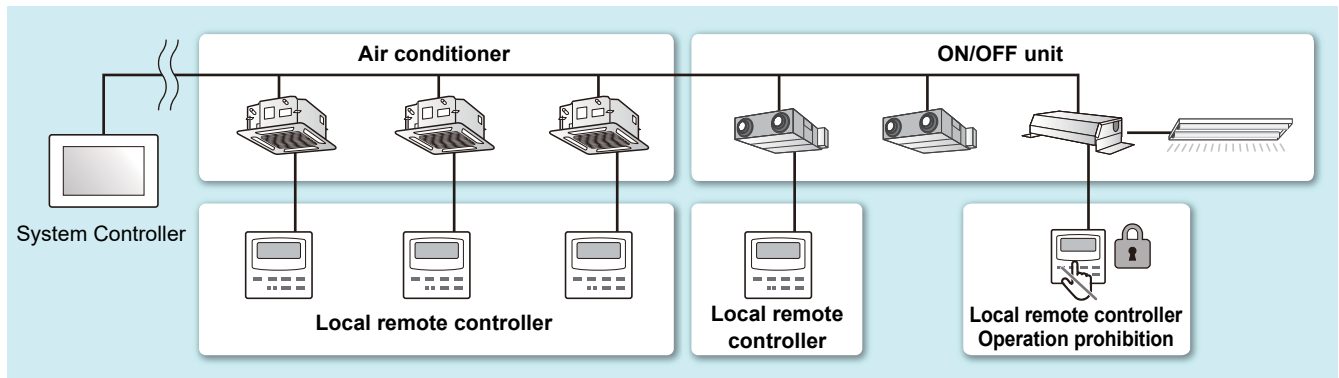

- 1 Display the [CONTROL] tab of the air conditioner(s) whose setting you want to change (P.22, 24) When changing in group units, display the batch settings screen (P.38)

In the following procedure, the [CONTROL] tab of the individual control screen is used to explain.

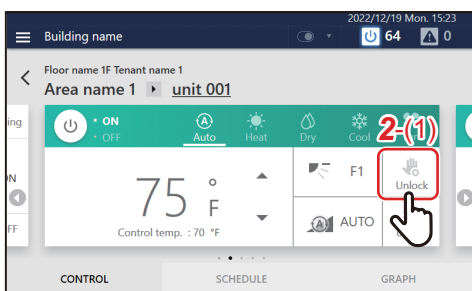

- 2 Tap [2-(1)]

NOTE

👉 appears if it is not locked. 🚫 appears if there is a locked item.

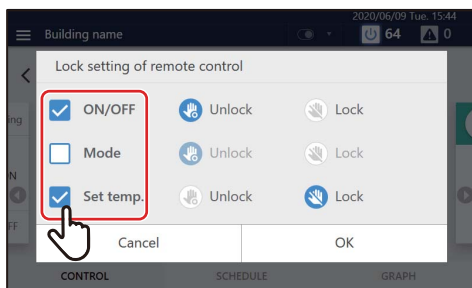

- 3 Tap the check box of the function whose setting you want to change to set it to

NOTE

The display items vary depending on the model.

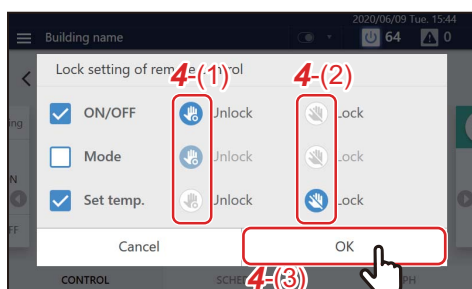

- 4 Select [4-(1)] or [4-(2)], then tap [4-(3)]

REQUIREMENT

If you set the check box to before tapping [4-(3)], the setting will not be applied.

NOTE

When local remote control operation is prohibited, if there is a power failure, the local remote control prohibited status will be cancelled when the power returns.

Ask service personnel if you want to continue the local remote control prohibited status after returning from a power failure.

NOTE

If you perform an operation that is locked with the local remote controller, the lock screen or a message will be displayed.

**Lock screen example
(Energy saving neo remote
controller)**

(Wired remote controller)

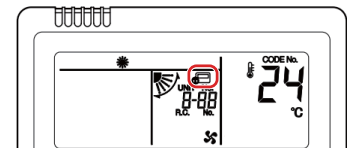
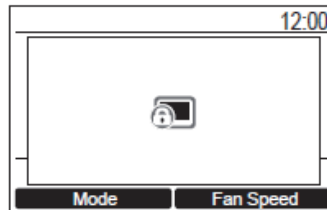

Set Operation Details

You can check the current settings of the air conditioner(s) or ON/OFF unit, and set the details of the operation method.

- 1 Display the [CONTROL] tab of the air conditioner(s) or ON/OFF unit whose setting you want to change (P.24)
When changing in group units, display the batch settings screen (P.38)

In the following procedure, the individual control screen is used to explain.

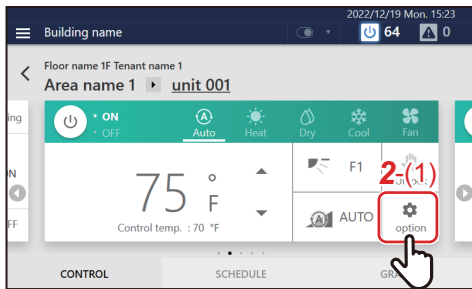

- 2 Tap [2-(1)]

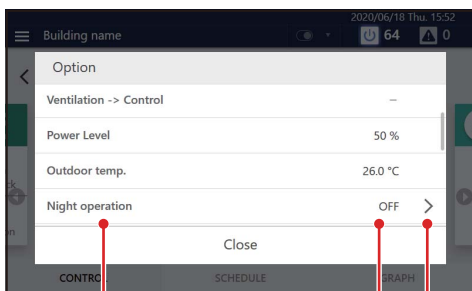

The option screen appears.

1

2

3

No.	Functions
1	The function name appears.
2	The currently set contents are displayed. If the settings are invalid, "-" is displayed.
3	When the settings can be changed, > is displayed. Tap to display the settings screen.

- 3 Scroll up and down to display the items you want to set/check

4 To change, tap > to display the settings screen, then tap [OK] after changing the settings

For details on the confirmation/setting contents of each item, refer to the following. The items displayed depend on the model and state.

Options for air conditioners

Function Name	Overview	Setting Items	Reference Page
Ventilation → ON/OFF	Controls the operation of the ventilator connected to the air to air heat exchanger(s) or the air conditioner(s).	ON/OFF	P.56
Ventilation → Mode	Controls the ventilation mode of the ventilator connected to the air to air heat exchanger(s) or the air conditioner(s).	Bypass/Heat exchange/Automatic	P.56
Ventilation → Fan speed	Controls the operation of the ventilator connected to the air to air heat exchanger(s) or the air conditioner(s).	Low, Medium, High, Unbalance Low, Unbalance High, Auto	P.56
Ventilation → Control	24-hour ventilation/Nighttime heat purge	–	–
Power Level	You can monitor the output status of the air conditioner(s).	–	P.56
Outdoor temp.	You can monitor the outdoor temperature detected by the outdoor unit.	–	P.57
Humidification setting	The humidification setting of the indoor unit can be set.	Auto, Disable	
Excessive CO ₂ concentration setting	Settings of CO ₂ concentration excess and threshold can be set. If the setting is enabled, Check Code S36 is generated when the CO ₂ concentration exceeds the threshold.	Setting: Enable, Disable Threshold: 100 ppm to 3000 ppm * Can be set in units of 100 ppm	
Night operation setting (VRF, LC, ESTIA)	Outdoor units can be set to low sound.	ON/OFF	P.57
Night operation setting (RAC)	Outdoor units can be set to low sound.	OFF, Night operation 1, Night operation 2	P.57
Filter sign reset	You can clear the FILTER Sign. You can clear the Hour.	OK/Cancel	P.58
Inspection	You can check the check code that has occurred.	–	–
Soft Cooling	You can set to Middle COOL.	ON/OFF	P.58
Energy saving ratio [%]	You can control the cooling/heating output of the air conditioner(s).	Release (100%)/ Max.(50 - 100%)/50/0	P.58
Saving operation	You can operate the indoor unit by saving the power.	ON/OFF	P.58
Forced Thermo OFF	You can release Thermo OFF.	Invalid	P.58
Return Back	You can control Return Back.	Cool (release, enable), Heat (release, enable)	P.59
Power peak cut	You can monitor whether the outdoor unit is controlling demand.	–	P.59
Eco Temperature Shift	You can set whether to change (shift) the set temperature.	OK/Cancel	P.59
Frost protection	Frost protection can be controlled.	ON/OFF	P.59
Set temp. range limit	You can change the set temperature range for each operation mode.	64°F to 84°F (18°C to 29°C) * It may differ depending on the region and model.	P.60
HiPower	HiPower can be controlled.	ON/OFF	P.60
ECO	ECO can be controlled.	ON/OFF	P.60
Power Select	Power Select can be controlled.	50%, 75%, 100%	P.61
PURE	PURE can be controlled.	ON/OFF	P.61
Fireplace	Fireplace can be controlled.	OFF, Fireplace 1, Fireplace 2	P.61
Notice Code	Displays Notice Codes that occur during operations.	–	P.61
Check Code (During backup operation)	Displays Check Codes that occur during backup operations.	–	P.61
Unit information	Unit information can be confirmed.	–	P.62

Options for Air to Water Heat Pump (ATW)

Function Name	Overview	Setting Items	Reference Page
Auto mode	Auto mode can be controlled.	ON/OFF	P.62
Night set back	Night set back can be allowed.	Enable/Disable	P.62
Night operation setting (VRF, LC, ESTIA)	Outdoor units can be set to low sound.	ON/OFF	P.57
Hot water boost	Hot water boost can be controlled.	ON/OFF	P.62
Anti bacteria	Antibacterial can be allowed.	Enable/Disable	P.63
Frost protection	Frost protection can be controlled.	ON/OFF	P.59
ESTIA information	Shows the following operating statuses. Boiler operation, Comp operation, DHW heater, Heater, Pump 1 operation, Pump 2 operation	–	P.63
Check Code (During backup operation)	Displays Check Codes that occur during backup operations.	–	P.61
Unit information	Unit information can be confirmed.	–	P.62

Turn ON/OFF the ventilation function

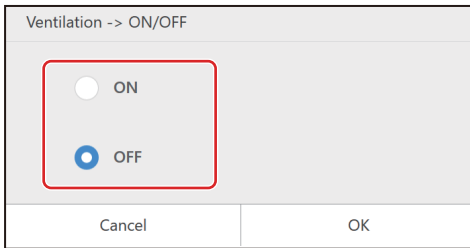

You can turn ON/OFF the operation of the ventilator connected to the air conditioner(s).

NOTE

Depending on the connected model, it may not be configurable.

Set ventilation mode

You can set the ventilation mode of the ventilator connected to the air to air heat exchanger(s) or the air conditioner(s). The settings screen displayed differs depending on the setting state of [Ventilation → ON/OFF].

When [ON] is selected under [Ventilation → ON/OFF]

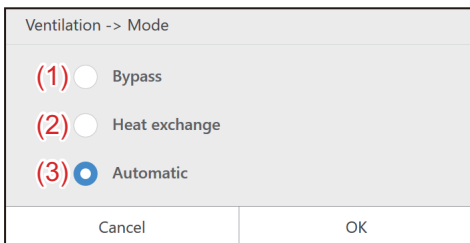

- (1) Bypass: Outdoor air is taken into a room as it is.
- (2) Heat exchange: Exchanging heat between the outdoor air and return air and making the temperature and humidity of the outdoor air closer to those of the return air before supplying it.
- (3) Automatic: Total Heat Ventilation and Bypass Ventilation are switched automatically.

NOTE

Depending on the connected model, some or all items may not be configurable.

Setting the ventilation fan speed

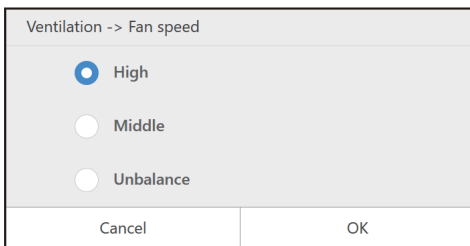

You can set the ventilation fan speed of the ventilator connected to the air to air heat exchange unit or the air conditioner. The choices displayed depend on the model.

NOTE

- Depending on the connected model, it may not be configurable.
- It is displayed when [Ventilation → ON/OFF] is [ON] and setting change is possible.

* Details for unbalance settings vary depending on the settings of the connected model.

Check the output status of the air conditioner(s)

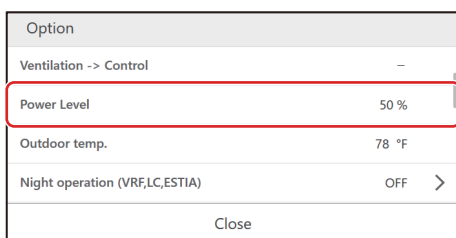

You can check how much power the air conditioner is using for operation.

NOTE

Depending on the connected model, it may not be displayed.

Check the outdoor temperature detected by the outdoor unit

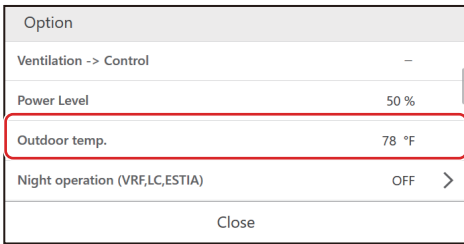

You can check the outdoor temperature detected by the outdoor unit.

NOTE

- Depending on the connected model, it may not be displayed.
- Depending on conditions such as the location of the outdoor unit installation, it may differ from the actual outdoor temperature.

Set humidification

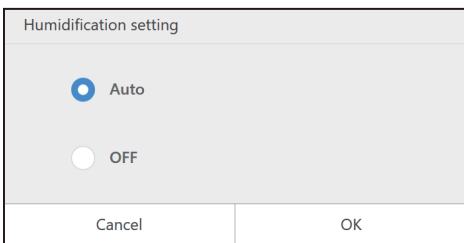

The humidification setting of the air conditioning can be set.

NOTE

- Depending on the connected model, it may not be displayed.
- Under automatic humidification, humidification is ON/OFF automatically according to the indoor environment.

Set the CO₂ concentration excess setting

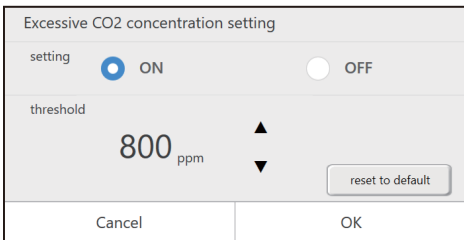

Settings of CO₂ concentration excess and threshold can be set.

If the setting is enabled, Check Code S36 is generated when the CO₂ concentration exceeds the threshold.

NOTE

- Depending on the connected model, it may not be displayed.

Make the night operation setting for the outdoor unit

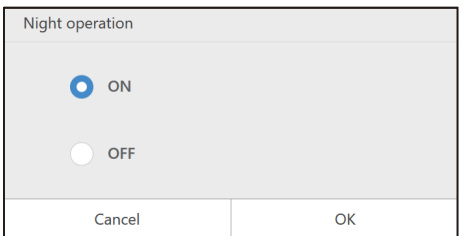

Monitor and control the ON or OFF state of the night operation of the target device.

This  is displayed to the right of the name when Night operation is in progress.

NOTE

- Depending on the connected model, it may not be displayed.
- When Night Operation is set, turn on the Silent Mode setting of the Hydro Unit to operate the Air to Water Heat Pump.

Filter sign Reset

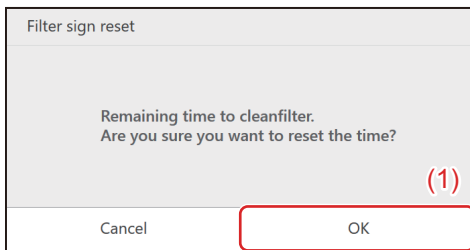

When a device has operated for a certain period of time, a warning (Filter sign) is displayed to indicate that the filter should be cleaned. After filter cleaning, tap [(1)].

NOTE

- Depending on the connected model, it may not be displayed.
- If you set the air conditioners where a sign is displayed to [OK], the cumulative time for the sign display is set to 0.

Set Soft Cooling

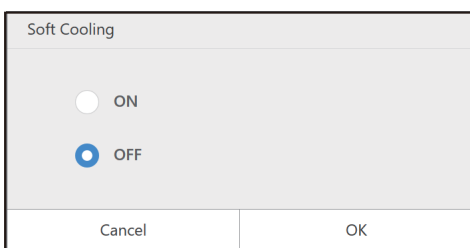

Soft Cooling can be turned ON/OFF. When turned ON, the air direction is set to up, and the maximum power is restricted.

NOTE

- Depending on the connected model, it may not be displayed.
- The settings screen is displayed when the air conditioner is in operation and the operation mode is COOL.

Control air conditioner power

An energy saving function whereby you can operate the air conditioner with suppressed cooling/heating power.

Release (100%): Save Mode is not performed.

Max.(50 - 100%): Operate with the highest save rate.

50: Operate at 50% save rate.

0: Operate at 0% cooling/heating power (Thermo OFF).

NOTE

Depending on the connected model, it may not be displayed.

Set saving operation

With one of the energy-saving functions, monitor and control the Valid or Invalid state of the saving operation of the air conditioner.

NOTE

Depending on the connected model, it may not be displayed.

Release thermo OFF

"Thermo OFF" refers to an energy saving function that controls demand to restrict the cooling/heating power of the air conditioner such that the outdoor unit compressor is stopped. When this state is reached, the air conditioner becomes a fan and cold/hot air is no longer output.

To release Thermo OFF, display the settings screen and press [OK].

NOTE

Depending on the connected model, it may not be displayed.

Configure and confirm the Return Back settings

You can configure and check the Return Back setting temperature and setting time of each operation mode that are set in the operating schedule.

NOTE

- Depending on the connected model, it may not be displayed.
- For information on Return Back, see “Return Back settings” (P.68).

Monitor power peak cut of outdoor unit

You can monitor the power peak cut, outdoor line No., and schedule No. of the outdoor unit connected to the selected air conditioner.

Display the settings screen to check the power peak cut status of the outdoor unit.

NOTE

Depending on the connected model, it may not be displayed.

Change to energy saving temperature

An energy saving function that changes (shifts) the set temperature according to the current operation mode as follows.

Operation Mode	Set Temperature Shift Width
Cool/Dry	Current set temperature +2°C shift (About +4°F)
Heat	Current set temperature -2°C shift (About -4°F)
Auto/Fan	Remain at current set temperature

NOTE

Depending on the connected model, it may not be displayed.

Frost protection

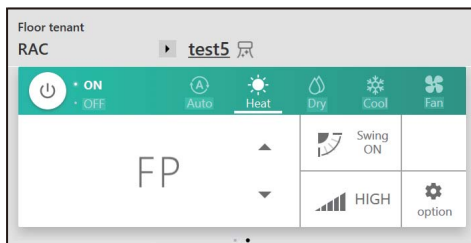

This function monitors and controls frost protection.

Frost protection can only be set when heating is on.

FP is displayed in the place that the set temperature is displayed while frost protection is operating.

Frost protection is disabled by the following operations, unless disabled from the frost protection settings.

- Indoor unit is turned off.
- Operation mode is changed to something other than heating.
- Set temperature is changed.

NOTE

May not be displayed, depending on the model connected.

Set the temperature change range

You can set the set temperature range for each operation mode.

NOTE

- Depending on the connected model, it may not be displayed.
- If the current set temperature of the air conditioner is outside of the set temperature range after the change, it will be changed to the temperature within the range after the change.
- If you use wireless remote controller, wireless remote controller may set a temperature outside the set temperature range specified by the Unit.

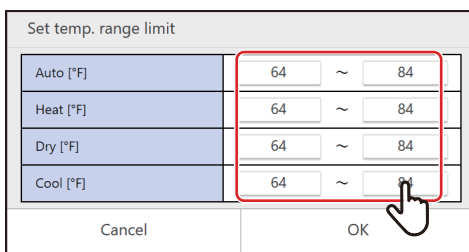

1 Tap the upper/lower limit temperature you want to change

NOTE

Depending on the connected model, it may not be configurable.

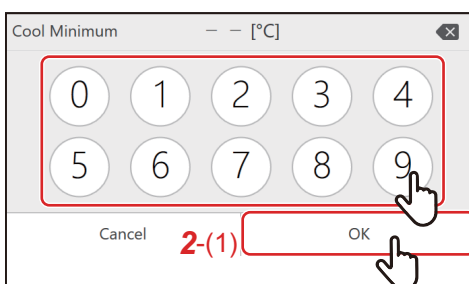

2 Tap the number, enter the temperature, and tap [2-(1)]

HiPower

This function monitors and controls HiPower operation of targeted equipment. While being controlled,  is displayed to the right of the unit name.

NOTE

May not be displayed, depending on the model connected.

ECO

This function monitors and controls ECO operation of targeted equipment. While being controlled,  is displayed to the right of the unit name.

NOTE

May not be displayed, depending on the model connected.

Power Select

This function monitors and controls Power select operation of targeted equipment. While being controlled,  is displayed to the right of the unit name.

- **NOTE**

May not be displayed, depending on the model connected.



PURE

This function monitors and controls PURE operation of targeted equipment. While being controlled,  is displayed to the right of the unit name.

- **NOTE**

May not be displayed, depending on the model connected.

Fireplace

This function monitors and controls Fireplace operation of targeted equipment. While being controlled,  /  is displayed to the right of the unit name.

- **NOTE**

May not be displayed, depending on the model connected.

Notice Code

Displays Notice Codes that occur during operations.

- **NOTE**

May not be displayed, depending on the model connected.

Check Code (During backup operation)

Displays Check Codes that occur during backup operations.

- **NOTE**

May not be displayed, depending on the model connected.

Unit information

Displays the model name and production number.

• NOTE

May not be displayed, depending on the model connected.

Auto mode

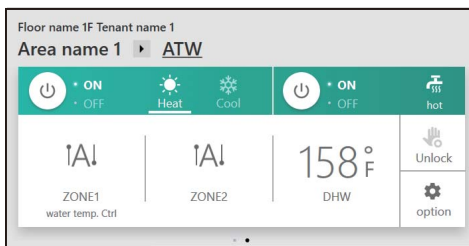

This function monitors and controls Auto mode.

By setting Auto mode to [Enable], |A| is displayed where the temperature setting is displayed, and the temperature setting cannot be changed.

• NOTE

May not be displayed, depending on the model connected.

Night set back

This function monitors and controls Night set back.

While being controlled, 🌙 is displayed to the right of the unit name.

• NOTE

May not be displayed, depending on the model connected.

Hot water boost

This function monitors and controls Hot water boost.

While being controlled, 🔥 is displayed to the right of the unit name.

The actual operation depends on the time at the local remote control.

For details, refer to the owner's manual for the local remote control.

• NOTE

May not be displayed, depending on the model connected.

Anti bacteria

Monitors and controls Anti bacteria operation.

While being controlled,  is displayed to the right of the unit name.

The actual operation depends on the time at the local remote control.

For details, refer to the owner's manual for the local remote control.

● NOTE

May not be displayed, depending on the model connected.

ESTIA information

Shows the following operating statuses.

- Boiler operation
- Comp operation
- DHW heater
- Heater
- Pump 1 operation
- Pump 2 operation

● NOTE

May not be displayed, depending on the model connected.

Change the Operating Schedule

The operating schedule settings can be changed from the [Menu] button, the group screen, or the individual control screen. There are two types of operating schedules: Weekly schedule and Special day schedule. The following procedure is explained using the individual control screen.

NOTE

If a day is set in both the Weekly schedule and the Special day schedule, the Special day schedule applies and the Weekly schedule is disabled for that day.

Change the details of the weekly schedule

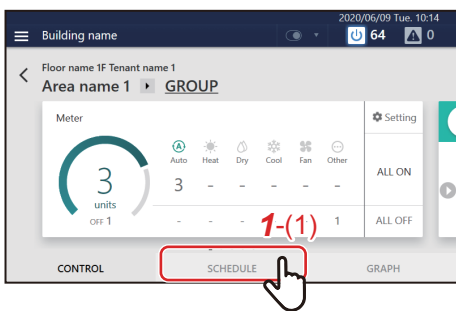

1 Tap [1-(1)] on the group screen or the individual control screen

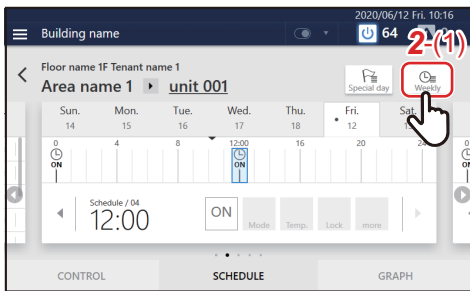

2 Tap [2-(1)]

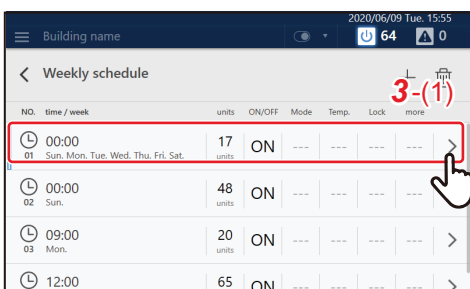

3 Tap [3-(1)] of the schedule you want to modify

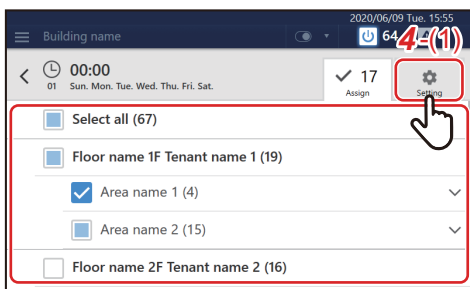

4 Modify the target air conditioner(s) or ON/OFF unit, then tap [4-(1)]

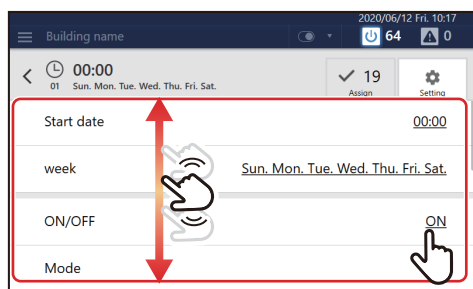

- 5** Scroll the screen and tap the value of the item you want to set. After changing the setting, tap [OK]
See "Setting items list" (P.68) for the items that can be configured.

Change the details of the special day schedule

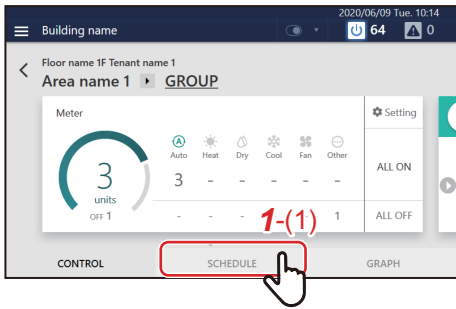

1 Tap [1-(1)] on the group screen or the individual control screen

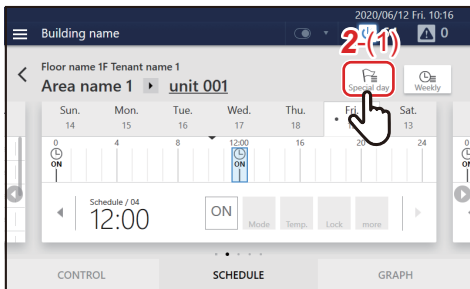

2 Tap [2-(1)]

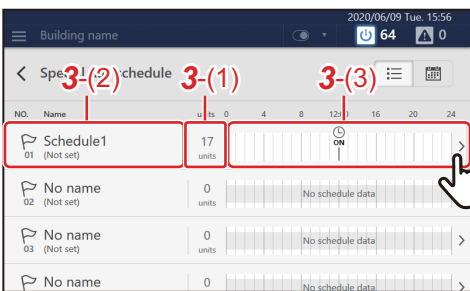

3 Tap [3-(1)] of the schedule you want to modify

- [3-(1)] Unit setting: Go to step 4
- [3-(2)] Special day setting: Go to step 5
- [3-(3)] Operating schedule setting: Go to step 6

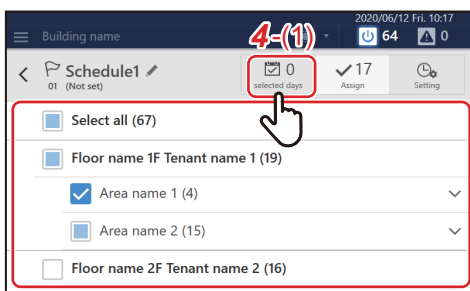

4 Modify the target air conditioner(s) or ON/OFF unit, then tap [4-(1)]

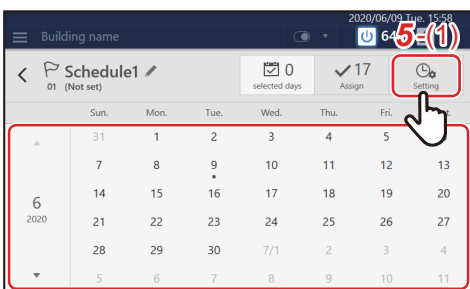

5 Tap the date you want to configure, modify the settings, and then tap [5-(1)]

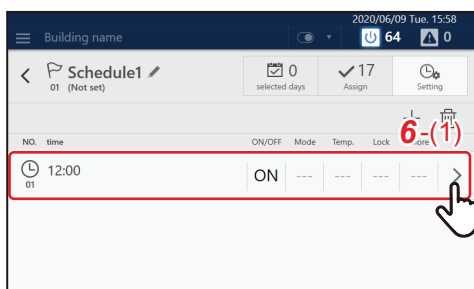

6 Tap [6-(1)] of the time you want to modify

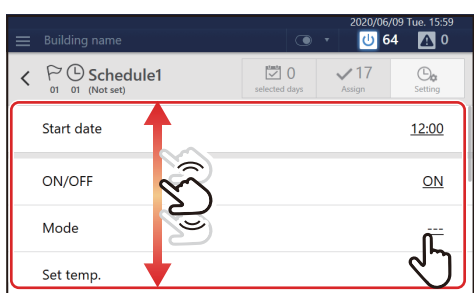



7 Scroll the screen and tap the value of the item you want to set. After changing the setting, tap [OK]

See "Setting items list" (P.68) for the items that can be configured.

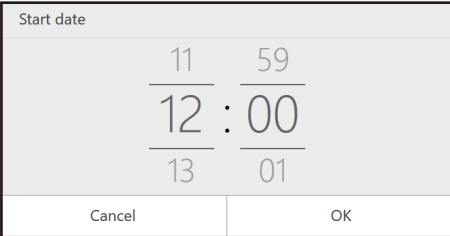
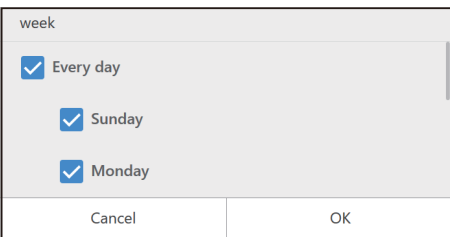
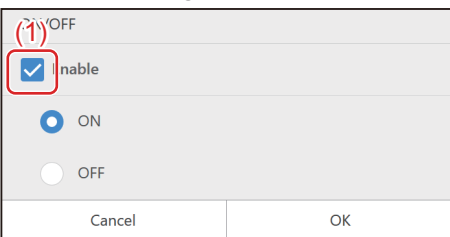
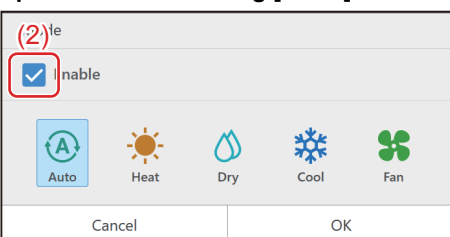
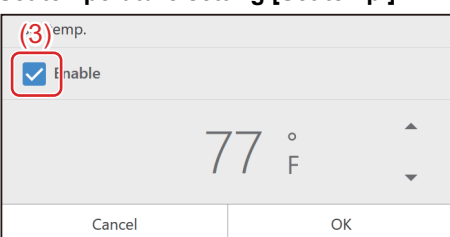
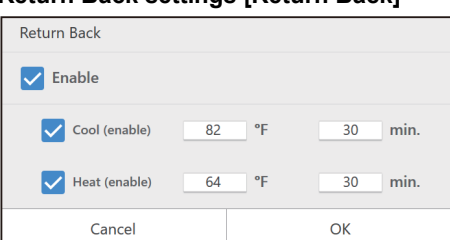
Setting items list

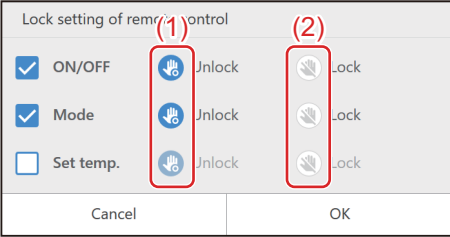
Setting Items	Setting Procedure
<p>Time setting [Start date]</p> 	<p>Tap or flick to change the time.</p>
<p>Day of the week setting [week]</p> 	<p>Set the check box(es) of the day(s) of the week on which you want to execute the schedule to <input checked="" type="checkbox"/>.</p> <p>NOTE</p> <p>The day of the [week] setting is not displayed in Special day schedule.</p>
<p>Operation setting [ON/OFF]</p> 	<p>To enable the setting, set the check box of [(1)] to <input checked="" type="checkbox"/> and select a value.</p> <p>NOTE</p> <p>Hot water supply function of the ATW cannot be set to [ON, OFF] by this setting.</p>
<p>Operation mode setting [Mode]</p> 	<p>To enable the setting, set the check box of [(2)] to <input checked="" type="checkbox"/> and select a value.</p>
<p>Set temperature setting [Set temp.]</p> 	<p>To enable the setting, set the check box of [(3)] to <input checked="" type="checkbox"/>, tap ▲ ▼, then change the set temperature.</p>
<p>Return Back settings [Return Back]</p> 	<p>An energy saving function whereby if you temporarily change the set temperature to one which increases the load, you can automatically return to the energy saving set temperature after a certain time has elapsed. For example, if you set COOL to 82°F (28°C)/30 minutes, then if the set temperature is set to below 82°F (28°C), the Unit will return to 82°F (28°C) 30 minutes after the change.</p> <p>NOTE</p> <p>Displayed in the case of a compatible air conditioner.</p>

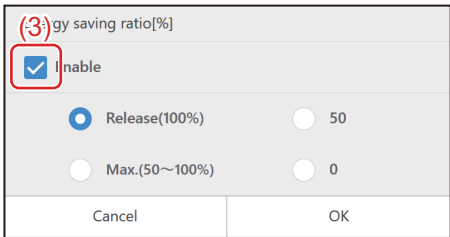
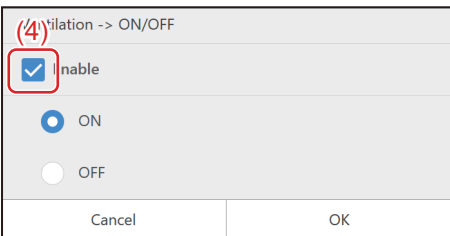
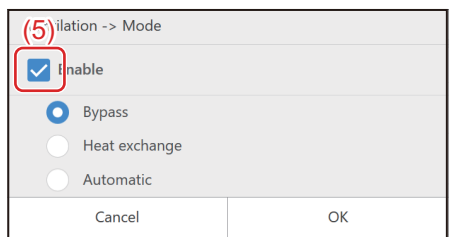
Setting Items	Setting Procedure
<p>Local operation prohibition setting [Lock setting of remote control]</p> 	<p>Tap the check box of the function whose setting you want to change to set it to <input checked="" type="checkbox"/>, then select [(1)] or [(2)].</p>
<p>Night operation setting [Night operation]</p> 	<p>You can change the [ON/OFF] of the night operation of the target device.</p>
<p>Save operation setting [Energy saving ratio[%]]</p> 	<p>To enable the setting, set the check box of [(3)] to <input checked="" type="checkbox"/>. For details, see "Control air conditioner power" (P.58).</p>
<p>Ventilation operation setting [Ventilation → ON/OFF]</p> 	<p>You can turn ON/OFF the operation of the ventilator connected to the air conditioner(s). To enable the setting, set the check box of [(4)] to <input checked="" type="checkbox"/> and apply the setting.</p> <p>NOTE</p> <p>Set the ventilation of the air to air heat exchanger connected individually from the operation setting [ON/OFF].</p>
<p>Vent. Mode [Ventilation → Mode]</p> 	<p>You can set the ventilation mode of the ventilator connected to the air to air heat exchanger(s) or the air conditioner(s). To enable the setting, set the check box of [(5)] to <input checked="" type="checkbox"/> and apply the setting. For details, see "Set ventilation mode" (P.56).</p>

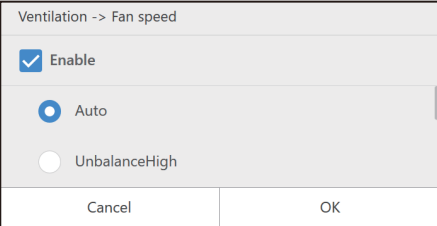
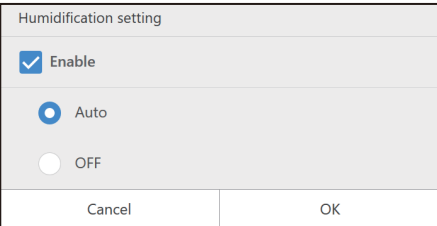
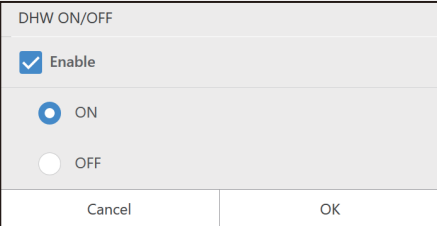
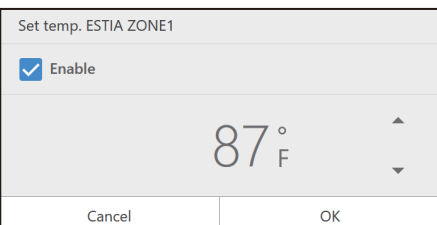
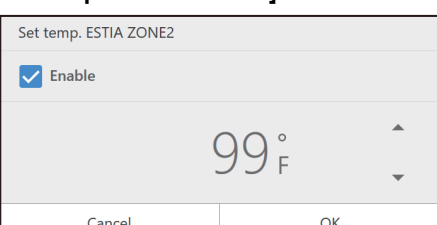
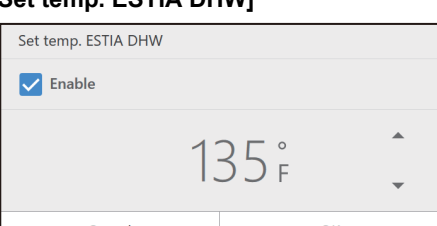
Setting Items	Setting Procedure
<p>Ventilation → Fan speed</p> 	<p>You can set the ventilation fan speed of the ventilator connected to the air to air heat exchange unit or the air conditioner.</p> <p>* Details for unbalance settings vary depending on the settings of the connected model. To enable the setting, set the check box of [Enable] to <input checked="" type="checkbox"/> and apply the setting. For details, see "Setting the ventilation fan speed" (P.56).</p>
<p>Humidification setting</p> 	<p>The humidification setting of the air conditioning can be set. To enable this setting, select <input checked="" type="checkbox"/> for the [Enable] checkbox, and then select [Auto/OFF].</p>
<p>DHW ON/OFF [DHW ON/OFF]</p> 	<p>This setting item is specifically for the Air to Water Heat Pump (ATW) in the hot water supply function.</p> <p>To enable this setting, select <input checked="" type="checkbox"/> for the [Enable] check box, and then select [ON, OFF].</p> <p>NOTE</p> <p>Indoor units, ON/OFF units, and the air conditioning function of the ATW cannot be set to [ON, OFF] by this setting.</p>
<p>ZONE1 Set temp. [Set temp. ESTIA ZONE1]</p> 	<p>This setting item is specifically for the Air to Water Heat Pump (ATW) in the air conditioning function.</p> <p>To enable this setting, select <input checked="" type="checkbox"/> for the [Enable] check box, and then tap ▲ ▼ to change the set temperature.</p>
<p>ZONE2 Set temp. [Set temp. ESTIA ZONE2]</p> 	<p>This setting item is specifically for the Air to Water Heat Pump (ATW) in the air conditioning function.</p> <p>To enable this setting, select <input checked="" type="checkbox"/> for the [Enable] check box, and then tap ▲ ▼ to change the set temperature.</p>
<p>Hot water setting temperature [Set temp. ESTIA DHW]</p> 	<p>This setting item is specifically for the Air to Water Heat Pump (ATW) in the hot water supply function.</p> <p>To enable this setting, select <input checked="" type="checkbox"/> for the [Enable] check box, and then tap ▲ ▼ to change the set temperature.</p>

Delete the operation schedule

You can delete the schedule from either the group screen or the individual control screen. In the following procedure, the individual control screen is used.

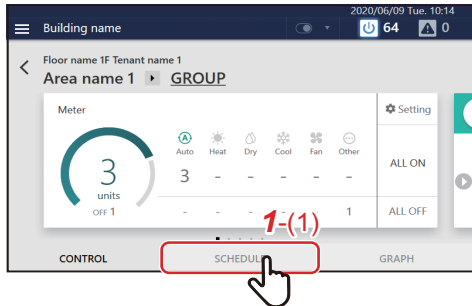

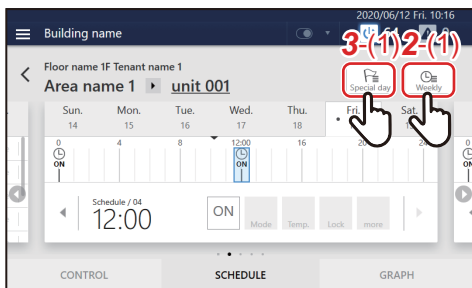

1 Tap [1-(1)] on the group screen or individual control screen

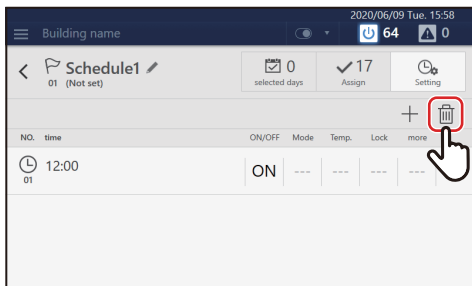
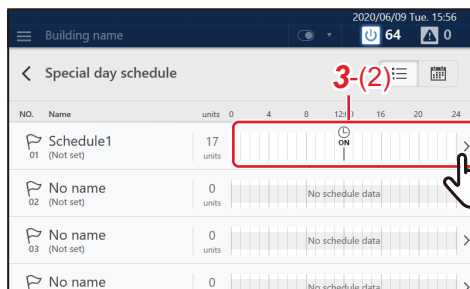

2 Tap [2-(1)] to go to step 4

3 (In case of Special day setting) tap [3-(1)]
Tap [3-(2)] of the schedule you want to modify to go to step 4.



4 Tap 
(Some displayed items differ between the Weekly schedule screen and the Special day schedule screen, but the procedure shown below is the same.)

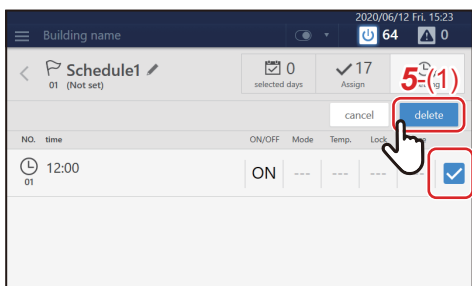

5 Set the check box of the schedule you want to delete to
then tap [5-(1)]

Confirm the Operation Time

In the [GRAPH] tab of the group screen or individual control screen, you can check the operation time for each group, air conditioner or ON/OFF unit.

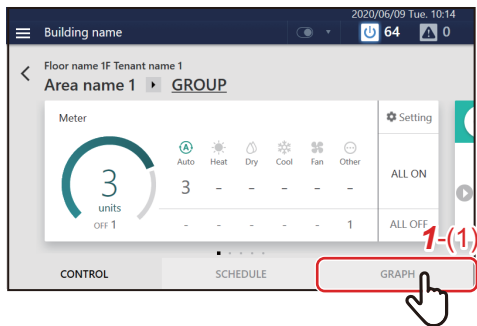

1 Tap [1-(1)] on the group screen or individual control screen

The operation graph appears.

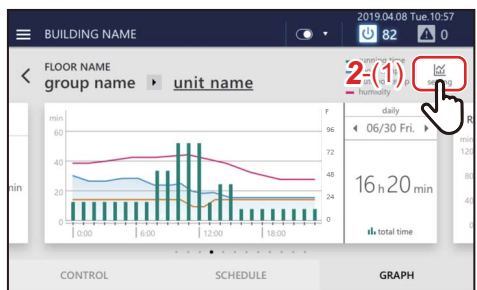

2 Tap [2-(1)]

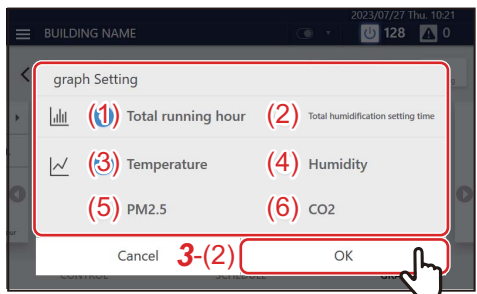

3 Select a graph to display and tap [3-(2)]

Selected operation graph appears.

- (1) Total running hour:
- (2) Total humidification setting time:
- (3) Temperature:
- (4) Humidity:
- (5) PM2.5:
- (6) CO₂:

Group screen

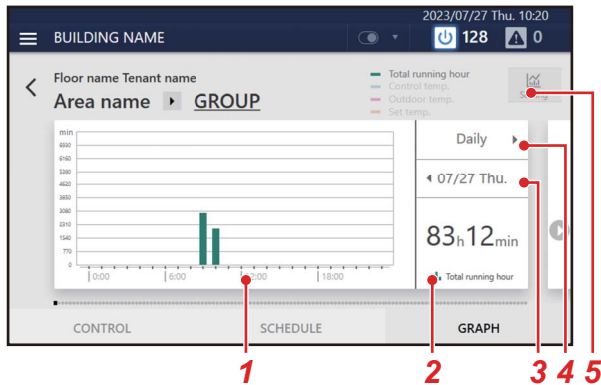

Individual control screen

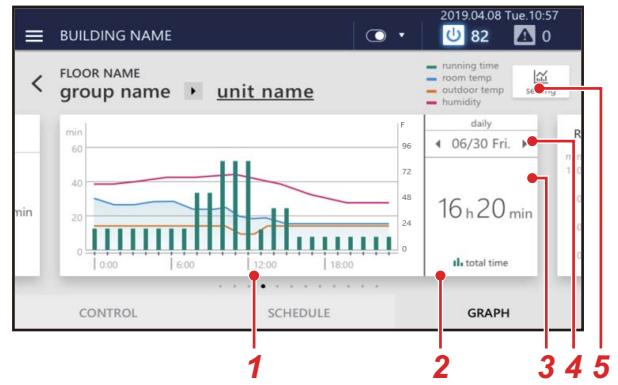

No.	Functions
1	Items selected from the air conditioning running time and humidification setting time are displayed in a bar graph on an hourly or daily basis. * For the individual control screen, items selected from the temperature (outdoor temperature, room temperature, set temperature), humidity, CO ₂ and PM2.5 are displayed in a line graph. The graph may not be displayed depending on the model connected.
2	The operation hours for the displayed summary period is displayed. *
3	Displays the currently displayed date. Tap ◀ ▶ to switch the date. Tap the centre to select the display period from the calendar screen.
4	You can change the summary unit to day or month.
5	The legend for the graph appears.

* The time that the Air to Water Heat Pump (ATW) is operating only as a hot water supply function is not included in the operating time graph.

Display the Owner's Manual on the Screen

You can browse the owner's manual on the screen.

How to display the owner's manual

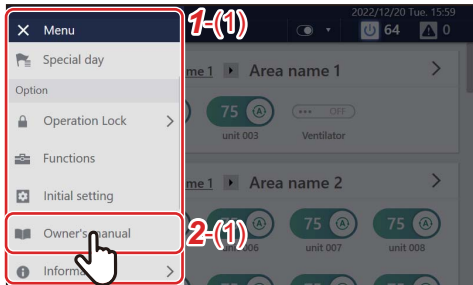

1 Tap [1-(1)] appears.

2 Tap [2-(1)]

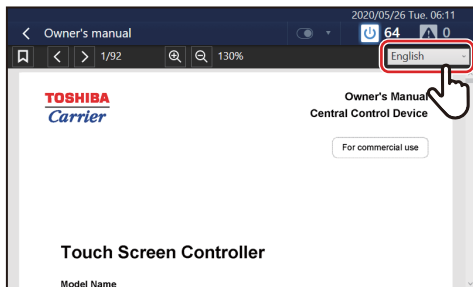

3 Select the display language
The owner's manual is displayed.

Owner's manual screen description

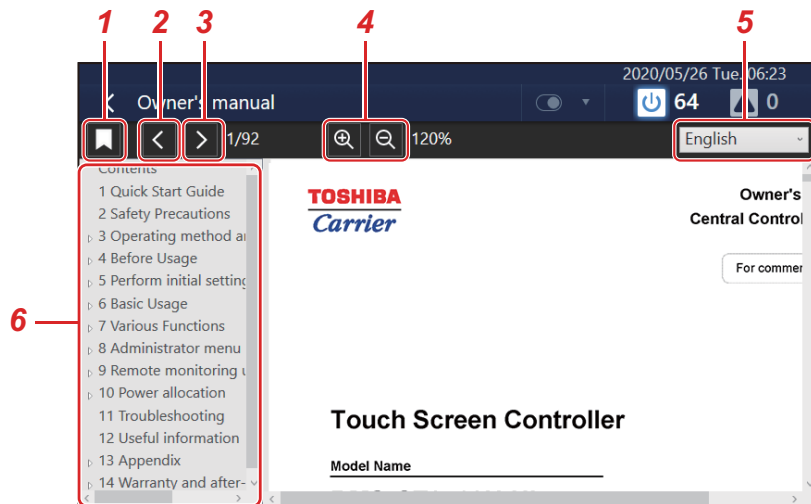

No.	Name (Icon)	Functions
1	Bookmark	You can switch bookmarks between display and non-display.
2	Previous page	Displays the previous page.
3	Next page	Displays the next page.
4	Enlarge, reduce	Used to enlarge and reduce the display.
5	Language selection	Select the display language.
6	Bookmark list	Displays the title of each chapter. Tap a title to display the relevant page.

8 Administrator Menu

Confirm Check Code History

You can display failures that have occurred in a list, including currently occurring ones. This can be used for grasping the status of the site such as investigating the cause of a failure and the recovery status.

NOTE

The past 1,000 check codes are displayed.

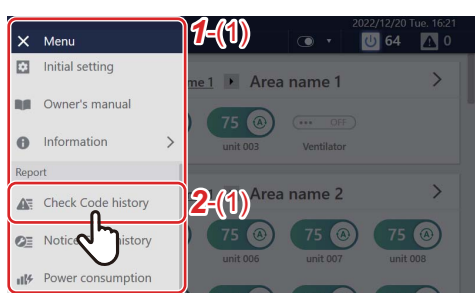

- 1 Tap [1-(1)] appears.
- 2 Tap [2-(1)]

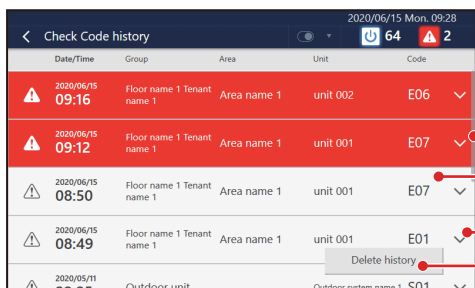

The detected check codes are listed in chronological order.

- Currently occurring check codes are displayed with a red.
- Past check codes are displayed with a white background.
- Tap to display the details of the check code contents.
- You can delete the check code history.

Confirm Notice Code History

You can display notices that have occurred in a list, including currently occurring ones. For details, confirm with the dealer.

Confirm the Power Consumption on a Graph

Pulse values are graphed and the electric power can be visually confirmed.

* This function can be displayed when the electric power is measured by connecting this Unit to a pulse transmission type watt hour meter.

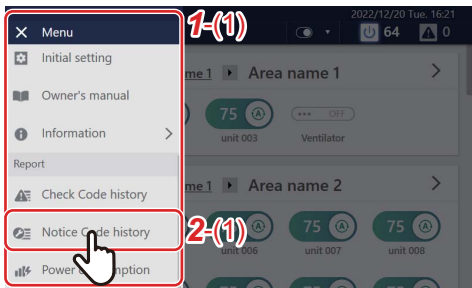

1 Tap [1-(1)] appears.

2 Tap [2-(1)]

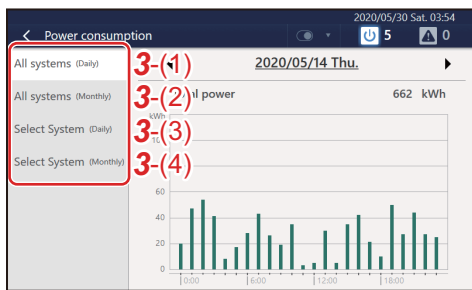

3 Tap the data type to be displayed

3-(1) All systems (Daily): You can display the total electric power on a daily basis on a graph.

3-(2) All systems (Monthly): You can display the total electric power on a monthly basis on a graph.

3-(3) Select System (Daily): You can select the watt hour meter to sum and display the daily electric power on a graph.

3-(4) Select System (Monthly): You can select the watt hour meter to sum and display the monthly electric power on a graph.

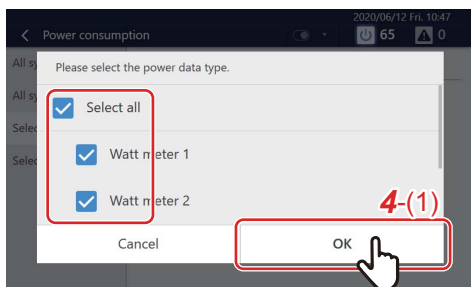

4 To select [3-(3)] or [3-(4)], set the check box of the watt hour meter to sum to and tap [4-(1)]

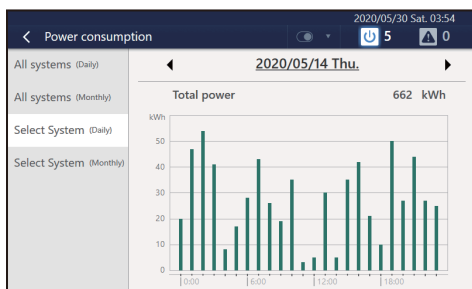

An electric power graph is displayed.

NOTE

Tap to change the summary period to display. You can also tap the displayed date to display the calendar and change the summary period.

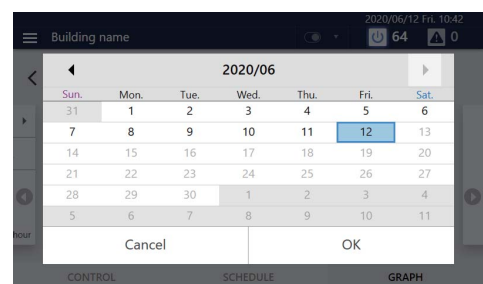

Restrict Operation of the Touch screen controller

You can restrict the operation range of the Unit by locking it.

This section explains how to set and release the lock.

For the restriction range, see "Set the operation lock level" (P.88).

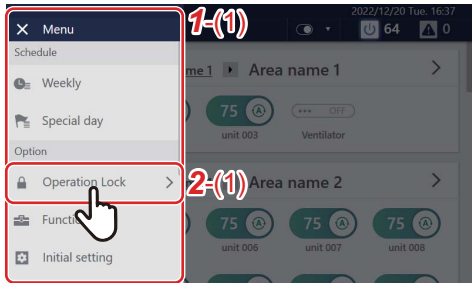

1 Tap [1-(1)] appears.

2 Tap [2-(1)]

Below, the screen for release is explained.

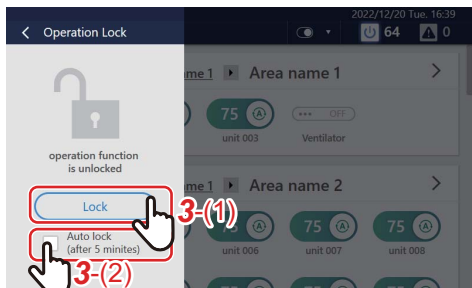

3 Tap [3-(1)]
To change the auto lock settings, tap [3-(2)]

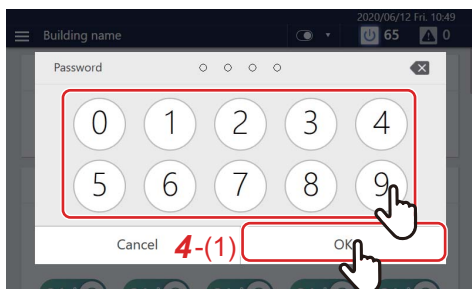

4 Tap the number, enter the 4-digit password, then tap [4-(1)]

The lock is set or released.

NOTE

- The initial set password is "1048".
- There are two levels of protection when locking. (P.88)
- Tap to delete one character.

NOTE

- You can change the password. (P.88) If you do not know the password, please contact your administrator.
- If you enter the wrong password three times when unlocking, password input is restricted for 30 minutes.
- When automatic lock is set, the Unit will be locked automatically after 5 minutes have passed after an operation has completed.
- When the lock is set, if you tap a function that cannot be operated, the message "operation function is locked" is displayed. Also, appears in the menu.

[Functions] Menu Settings

On the [Functions] menu, demand control of outdoor units and summation of data for power distribution can be performed.

How to display the [Functions] menu

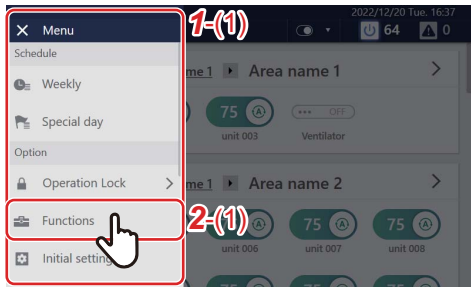

1 Tap [1-(1)] appears.

2 Tap [2-(1)] [3-(1)] appears.

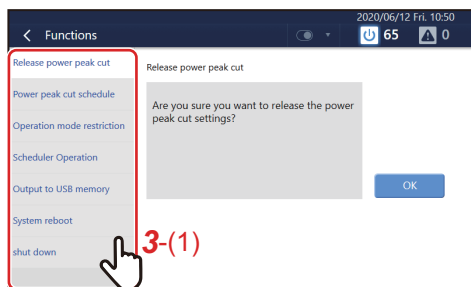

3 Tap the item you want to set with [3-(1)]

The settings screen of the selected item appears on the right.

For details on the setting contents of each item, refer to the following.

- Release power peak cut (P.78)
- Power peak cut schedule (P.79)
- Operation mode restriction (P.81)
- Scheduler Operation (P.81)
- Output to USB memory (P.82)
- System reboot (P.82)
- Shut down (P.82)

Release demand control of outdoor unit

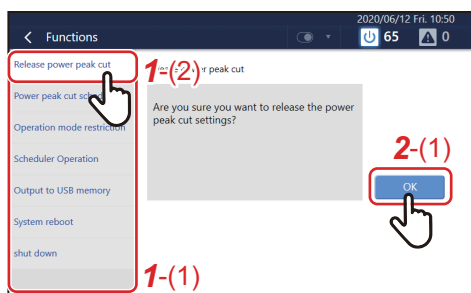

1 Tap [1-(2)] with [1-(1)]

2 Tap [2-(1)]
Outdoor demand set for all outdoor units is released.

NOTE

- Outdoor demand can be set by the "Power peak cut schedule". (P.79)
Outdoor demand may function with digital input set locally. In this case it can also be released.
- When you release the Power peak cut, the setting value of [Power peak cut] on the option screen changes to the release state. (P.59)

Set demand control schedule of outdoor unit

The demand function of the outdoor unit can be managed with the schedule to 100% to 0% according to the peak time zone.

Setting example:

If you set "80%" for 9:00 to 18:00,
 "90%" for 18:00 to 21:00, and
 "100% (No power peak cut)"
 for 21:00 to 9:00 on next day

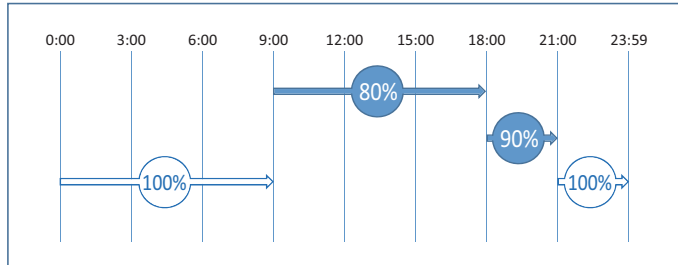

NOTE

- Cannot be set when the Outdoor Demand Schedule is disabled. Please enable the Outdoor Demand Schedule. (P.81)
- Demand levels that can be set are "100% (No power peak cut)", "90%", "80%", "70%", "60%" and "0%".
- Up to 10 schedules can be created.

Add/change power peak cut schedule

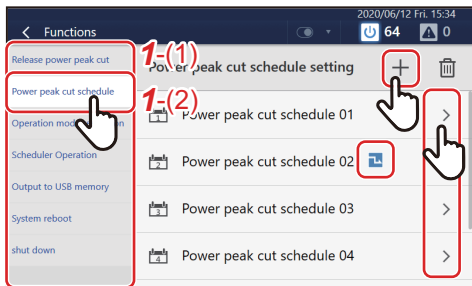

1 Tap [1-(2)] with [1-(1)] (P.78)

2 Tap + to register new
 To change, tap > of the schedule you want to change

NOTE

When the demand function is functioning at the current time, appears.

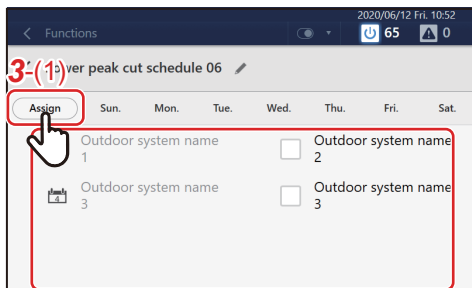

3 Tap [3-(1)] and set the check box of the outdoor unit for setting the Power peak cut schedule to

NOTE

The schedule number () will be displayed on outdoor units that have already been scheduled. Cannot be selected.

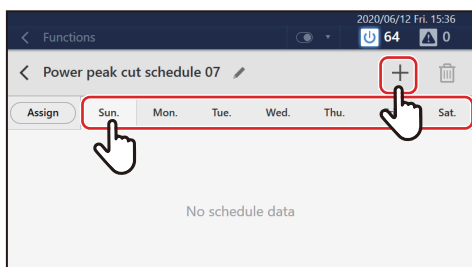

4 Tap the day of the week tab to start the schedule, then tap +
 To change an already registered schedule, tap > on the corresponding schedule

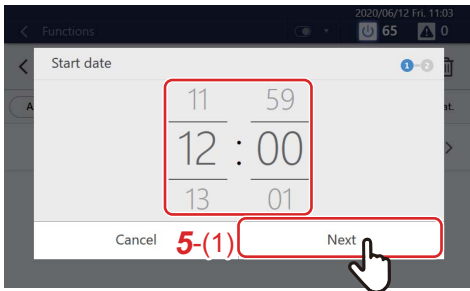

5 Tap or flick to set the start time and tap [5-(1)]

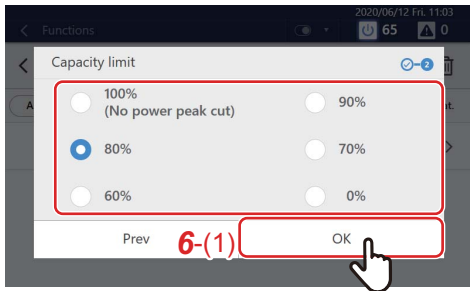

6 Select the outdoor demand level and tap [6-(1)] to add a demand schedule

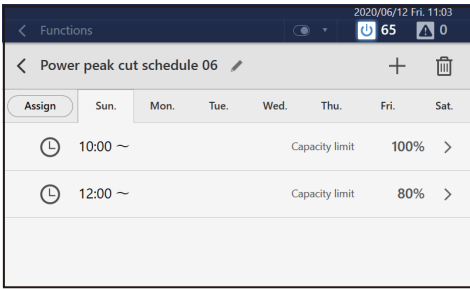

7 To add a schedule such as change/release of demand level, repeat steps 4 to 6

NOTE

- The outdoor demand initiated by the schedule is released in the following cases.
 - When 100% (No power peak cut) is set in the schedule
 - When demand control of the outdoor unit has been released (P.78)
- Demand control continues even across days.

Example: When the demand rate is set to 0% on Monday at 21:00 and release is set at 9:00 on Tuesday

→ The demand rate is set to 0% from Monday at 21:00 to Tuesday at 9:00 and demand release occurs at 9:00 on Tuesday



Delete a power peak cut schedule

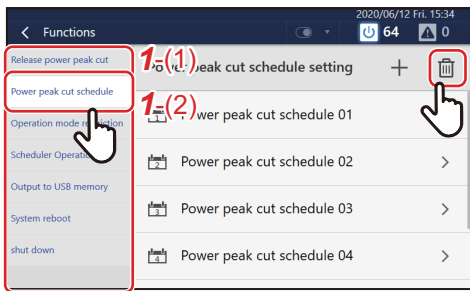

1 Tap [1-(2)] with [1-(1)] (P.78)

2 Tap

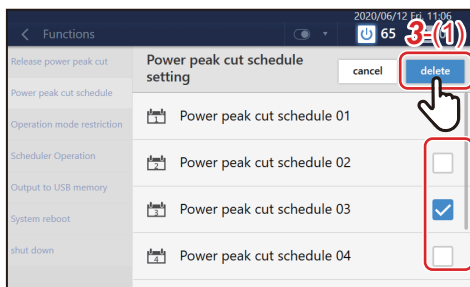

3 Set the check box of the schedule you want to delete to , then tap [3-(1)]

The selected schedule will be deleted.

NOTE

Also, when deleting a registered time, tap and operate similarly.

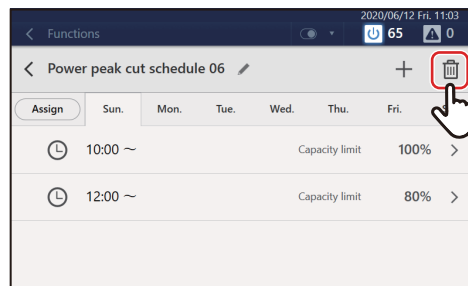

Restrict operation mode

When using an outdoor unit that cannot operate cooling and heating at the same time, you can restrict its operation mode so that it can only be set for either cooling or heating.

1 Tap [Operation mode restriction] in the [Functions] menu (P.78)

2 Select the operation mode and tap [OK]

NOTE

- Settings are reflected in all outdoor units.
- Even with restriction, the operation mode of the [CONTROL] tab can be selected. When a restricted operation mode is selected, the Thermo OFF state is set.

Set the operating schedule or the power peak cut schedule

You can disable registered Operation Schedules and Power peak cut schedules so that they do not operate.

1 Tap [Scheduler Operation] in the [Functions] menu (P.78)

2 Set the check box to if you do not want to operate each schedule, or set the check box to to operate them, then tap [OK]

Output data to a USB memory stick

You can output data for Energy Report Software 2 to a USB memory stick.

- 1** Connect the USB memory stick to the slot in the Unit
- 2** Tap [Output to USB memory] in the [Functions] menu (P.78)
- 3** Tap [OK]

NOTE

If the USB memory stick is not connected, [OK] will not be enabled.

Restart the unit

You can restart the Unit.
The schedule is not executed during restart.

- 1** Tap [System reboot] in the [Functions] menu (P.78)
- 2** Tap [OK]

Exit the system

Terminate the operation of the Unit.

NOTE

This function turns off the power to the System Controller.
It does not stop the air conditioners connected to the Unit.

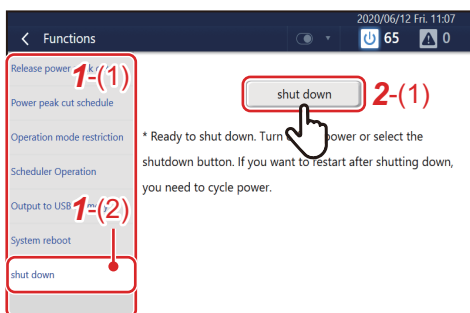

- 1** In [1-(1)], tap [1-(2)]
- 2** Tap [2-(1)]

[Initial setting] Menu Settings

On the [Initial setting] menu, you can change the Unit screen display and the settings for remote operation, etc.

How to display the [Initial setting] menu



1 Tap .
[1-(1)] appears.

2 Scroll through the menu list and tap [2-(1)].
[3-(1)] appears.

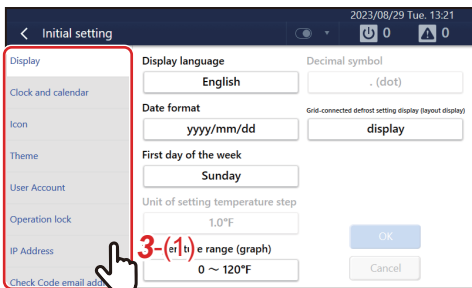

3 Tap the item you want to set with [3-(1)].
The settings screen of the selected item appears on the right.

For details on the setting contents of each item, refer to the following.

- Display (P.84)
- Clock and calendar (P.84)
- Icon (P.85)
- Theme (P.85)
- User Account (P.86)
- Operation lock (P.88)
- IP Address (P.89)
- Check code email address (P.90)
- Indoor unit area setting (P.91)
- Indoor unit name setting (P.93)
- Area name setting (P.93)
- Backlight (P.94)
- Power peak cut (P.94)

Set the screen display

You can change the display settings of the screen, such as language and date display format.

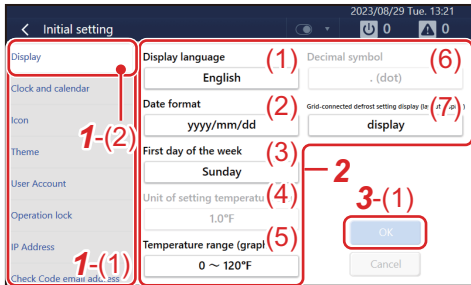

- 1 Tap [1-(2)] with [1-(1)] (P.83)**
- 2 Tap the item you want to change**

- (1) Language: You can change the display language of the screen.
- (2) Date format: You can change the format of the date displayed in the upper right of the screen.
- (3) First day of the week: You can change the first day of the week displayed on the calendar or schedule to Sunday or Monday.
- (4) Temperature setting step: Temperature setting step cannot be changed if the display unit is Fahrenheit.
- (5) Temperature range (graph): You can change the temperature range displayed on the [GRAPH] tab.
- (6) Decimal symbol: You can change the decimal symbol displayed on the screen between [. (dot)] and [, (comma)].
- (7) System cooperation defrosting settings: You can change the display settings for information on the system cooperation defrosting settings.
* For details, contact service personnel.

- 3 Select the value you want to change, then tap [3-(1)]**

Set the current date and time

You can change the date and time displayed in the upper right of the screen.

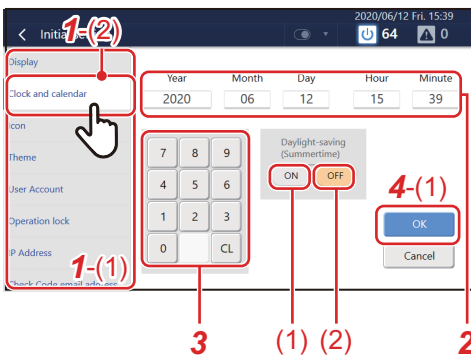

- 1 Tap [1-(2)] with [1-(1)] (P.83)**
- 2 Tap the item you want to change**
The characters of the selected item change to red.
- 3 Tap the numeric keypad to enter a number**
- 4 Tap [4-(1)]**

NOTE

You can set daylight saving time with [Daylight-saving (Summertime)]. When set to [(1)], the time moves one hour forward, and when set to [(2)], it moves one hour back. While daylight saving time is set,  appears in the upper right corner of the screen.

Set icons of devices other than air conditioners

You can display icons of each device on the [CONTROL] tab of devices other than air conditioners such as ventilation fan or lighting.

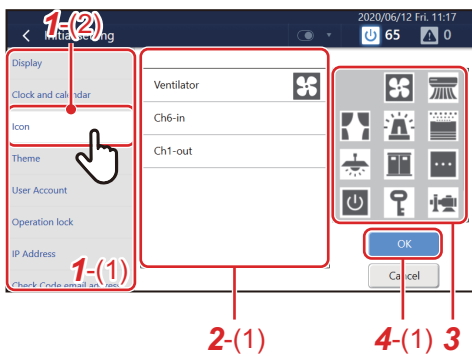
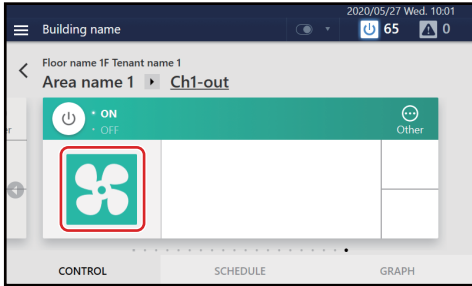

- 1** Tap [1-(2)] with [1-(1)] (P.83)
- 2** Tap the device you want to set with [2-(1)]
- 3** Tap the icon you want to set in the icon list
The selected icon is displayed in [2-(1)].
- 4** Tap [4-(1)]

NOTE

- To delete a set icon, select the device with [2-(1)] and then tap the space at the top left of the icon list.
- The following icons can be set:

	Ventilation fan/Circulator		Room air conditioner		Curtain		Alarm		Humidifier/Dehumidifier		Lighting
	Cubicle		Water storage tank		General switch		Security		Pump		Camera

Set the screen theme

You can set the theme of the home screen and the details/control screen.

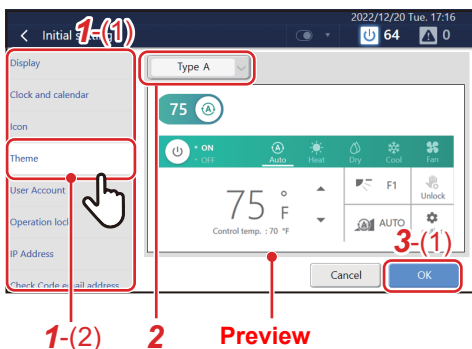

- 1** Tap [1-(2)] with [1-(1)] (P.83)
- 2** Tap the drop-down menu and select a theme
The selected theme appears in the preview. Operate the switch or tap the power supply or operation mode button to check the display after the change.
- 3** Tap [3-(1)]

Set an account for remote operation

You can set a user account to operate the Unit remotely.

* Remote operation can be used when the Unit is connected via LAN to a PC on which the Remote Control Software is installed.

NOTE

- 128 users can be registered.
- Up to 16 users can log in at the same time.
- At least one user must be registered.

Add/change user account

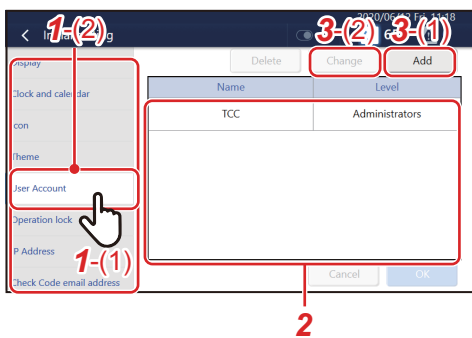

1 Tap [1-(2)] with [1-(1)] (P.83)

2 To change, tap the row you want to change in the list

NOTE

The following users are registered in advance.
You can also change/delete users.

Name:	TCC
Password:	TCC
Level:	Administrators

3 Tap [3-(1)] or [3-(2)]

In the following procedure, the screen in the case of addition is used to explain.

4 Set Name (only when adding) and password

Tap the entry field to display the keyboard. After entering the characters, tap [4-(1)].

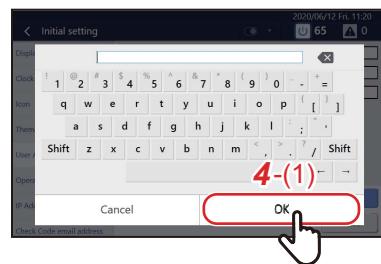
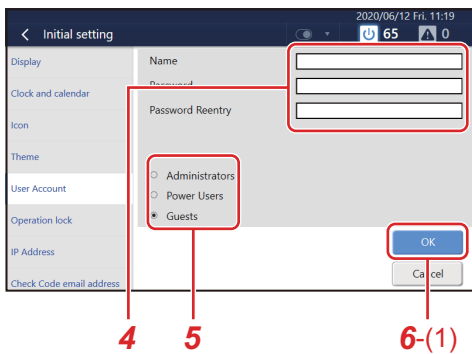

NOTE

- Tap [Shift] to toggle between upper case letters and lower case letters, and numbers and symbols.
- Tap  to delete one character.

5 Set level

Administrators : All functions can be used.

Power Users : The following functions cannot be used.

- Confirm/change the operation schedule
- [Menu] > Functions
- [Menu] > Initial setting

Guests : Only the operation status can be confirmed. The settings cannot be changed.

NOTE

For details on the functions that can be used for each level, see "List by Lock Level/Level" (P.111).

6 Tap [6-(1)]

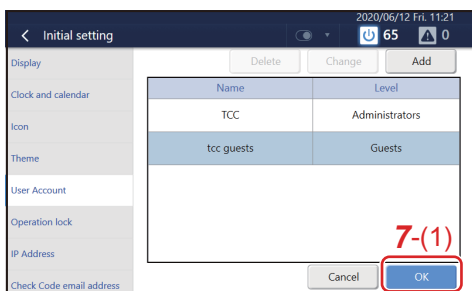

7 Tap [7-(1)]

Delete a user account

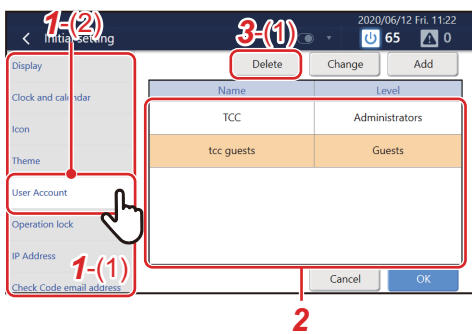

1 Tap [1-(2)] with [1-(1)] (P.83)

2 Tap the row you want to delete

3 Tap [3-(1)]

It will be deleted from the list.

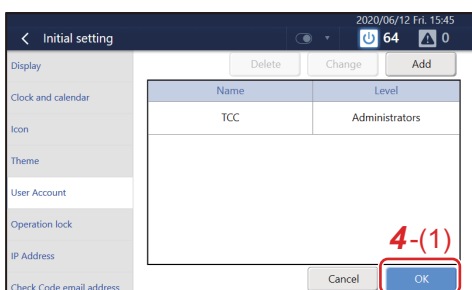

4 Tap [4-(1)]

Deletion is confirmed.

Set the operation lock level

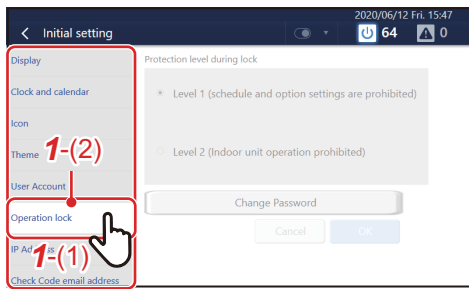

1 Tap [1-(2)] with [1-(1)] (P.83)

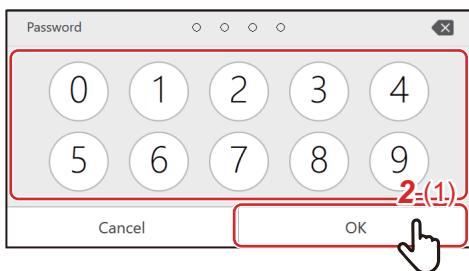

2 Enter the password and tap [2-(1)]

NOTE

The factory default setting password is "1048".

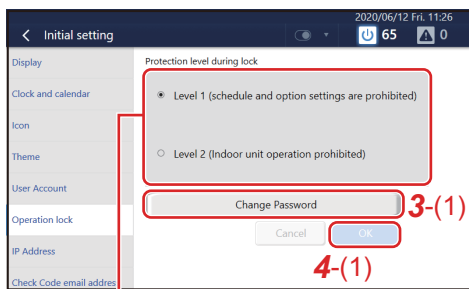

3

3 Select the protection level during lock

NOTE

You can change the password that sets the operation lock. Tap [3-(1)] to display the change password input screen. Enter the changed password, tap [OK], re-enter it on the re-entry screen, then tap [OK]. 4-digit passwords can be set.

4 Tap [4-(1)]

Set check code email destination

You can set the email address to send email to when an error occurs.

NOTE

Up to five email addresses can be set.

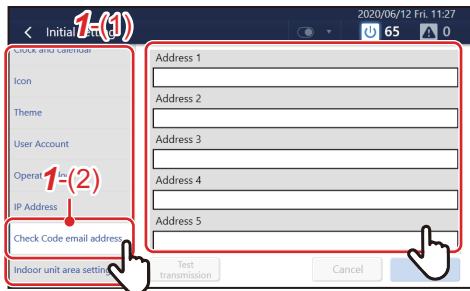

- 1 Tap [1-(2)] with [1-(1)] (P.83)
- 2 Tap the address field to register

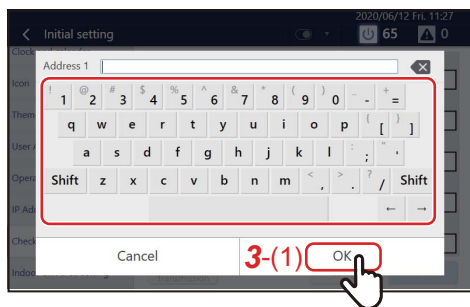

- 3 Enter the email address on the keyboard, then tap [3-(1)]

NOTE

- Tap [Shift] to toggle between upper case letters and lower case letters, and numbers and symbols.
- Tap  to delete one character.

- 4 Tap [OK]

NOTE

To test-send to the registered email address, tap [Test transmission], which displays after you tap [OK].

Change the area set for an indoor unit

In [Indoor unit area setting], you can move the indoor unit A in area X to area Y.

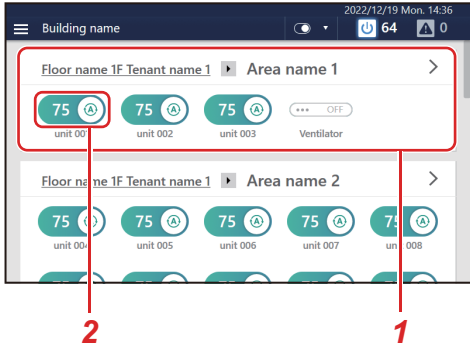

NOTE

- [1] All areas. The area numbers, such as area 1 and area 2, are allocated automatically in the upper section of the home screen.
- [2] Each indoor unit in the area.

The procedure below is used as an example to explain how to move the indoor unit (unit 001) set in area 1 to area 2.

- 1 Tap [1-(2)] in [1-(1)] (P.83)
- 2 Tap [2-(1)]

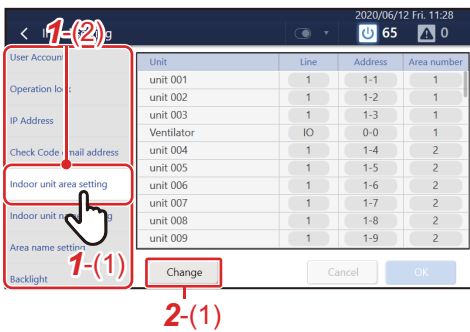

- 3 Select [3-(1)] and tap [3-(2)]

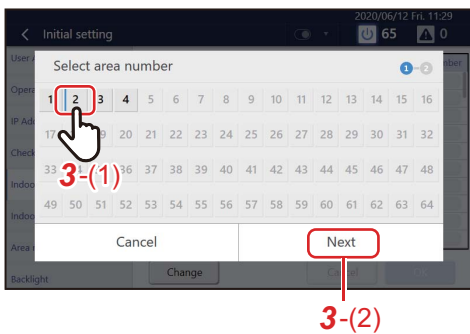

- 4 Set the check box of the indoor unit (unit 001) you want to move to area 2 to and tap [4-(1)]

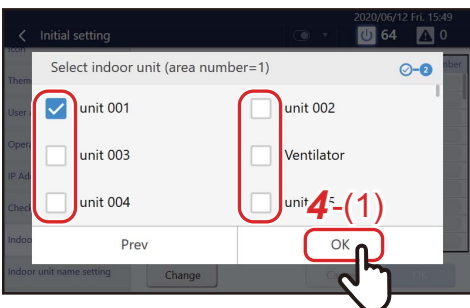

5 Tap [5-(1)]

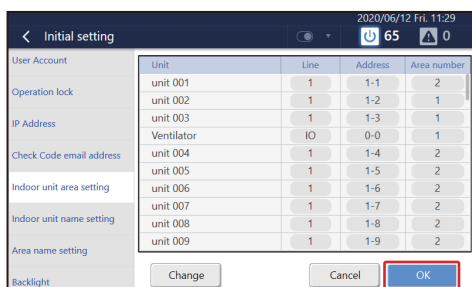

5-(1)

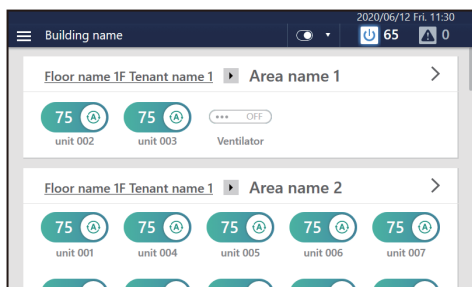

The indoor unit (unit 001) is moved to area 2.

Set the name of an indoor unit

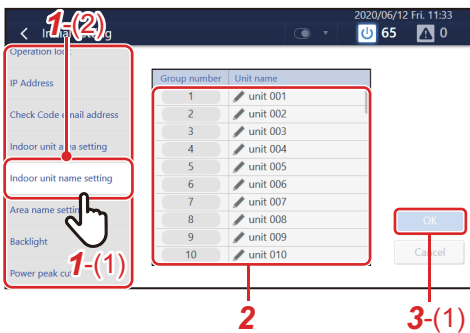

- 1** Tap [1-(2)] in [1-(1)] (P.83)
- 2** Tap the name you want to change in the list
A keyboard is displayed. Enter the name and then tap [2-(1)].

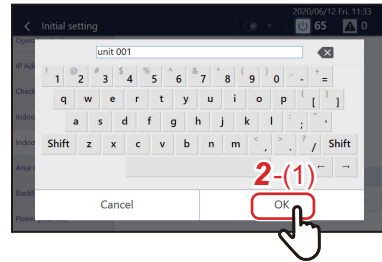

- **NOTE**
- Tap [Shift] to toggle between upper case letters and lower case letters, and numbers and symbols.
- Tap to delete one character.

- 3** Tap [3-(1)]

Set the area name

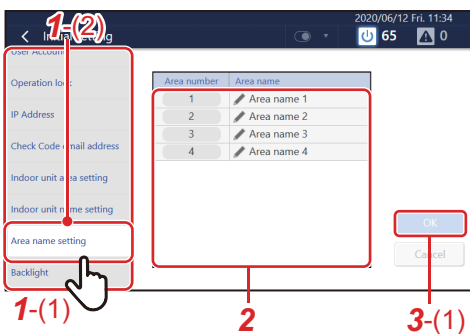

- 1** Tap [1-(2)] in [1-(1)] (P.83)
- 2** Tap the name you want to change in the list
A keyboard is displayed. Enter the name and then tap [2-(1)].

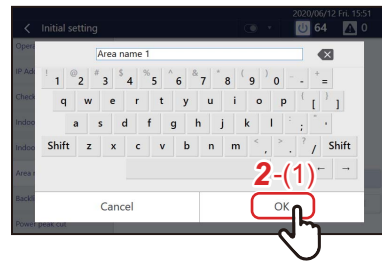

- **NOTE**
- Tap [Shift] to toggle between upper case letters and lower case letters, and numbers and symbols.
- Tap to delete one character.

- 3** Tap [3-(1)]

Set the screen brightness

You can set the brightness of the screen and the duration after the end of the operation. In (1, 3, 10, 30, 60, 360 (6 hours), 720 (12 hours) minutes)

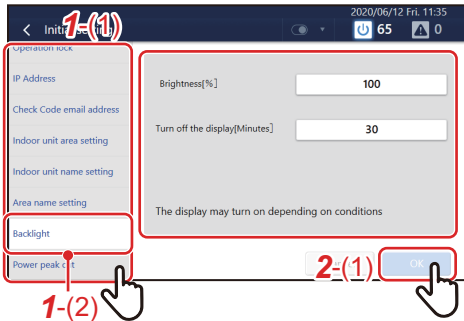

- 1 Tap [1-(2)] with [1-(1)] (P.83)
- 2 Select the brightness and tap [2-(1)]

Set power consumption control conditions

You can set the conditions for controlling power consumption peaks.

Based on the pulse signal from the pulse transmission type watt hour meter, the power usage is calculated, and if it exceeds the power usage threshold, an operation control signal is sent to the outdoor unit.

There are two different settings:

- Energy threshold: Controls operation based on the pulse signal from the pulse transmission type watt hour meter.
- Peak cut signal reception: Controls operation based on the signal from the external demand device.

NOTE

Before setting these items, initial settings are required. For details, contact service personnel.

System diagram

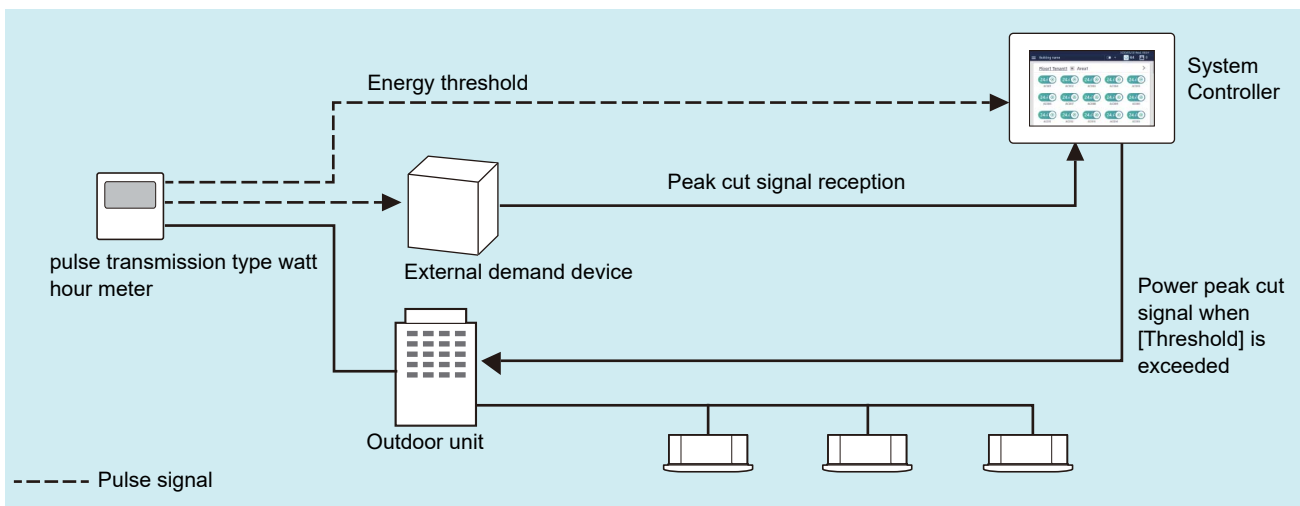

Set Energy threshold

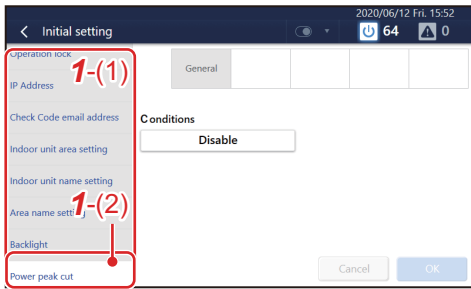

1 In [1-(1)], tap [1-(2)]

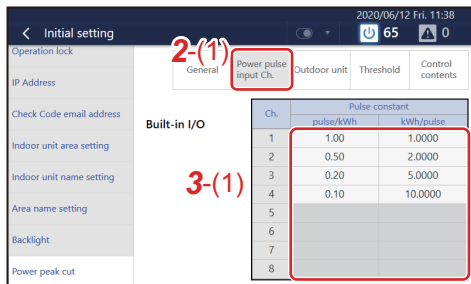

2 Tap [2-(1)]

3 Tap [3-(1)] and set the pulse constant for each of channels 1 to 8

NOTE

- Ensure that the pulse constant matches the output pulse of the pulse transmission type watt hour meter connected to the Unit.
- Channels 1 to 8 correspond to external input terminals DIs 1 to 8.
- Enter each pulse constant in either the [pulse/kWh] or [kWh/pulse] field. In the field in which no pulse constant is entered, the reciprocal of the entered value is displayed.
- Before setting these items, initial settings are required. For details, contact service personnel.

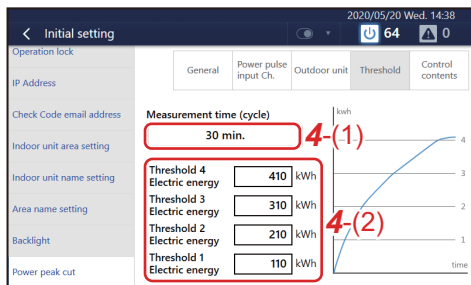

4 Set data in [4-(1)] and [4-(2)]

NOTE

- In Measurement time, set the measurement time for power usage.
- For Threshold 1 to Threshold 4, set the power usage in the measurement time cycle.
- A threshold of 0 means that no threshold is set.
- Enter thresholds, starting with Threshold 1, in such a way that the threshold gets larger as the number increases. You cannot skip any number.
- If the actual power usage is 250 kWh, Threshold 1 (110 kWh) and Threshold 2 (210 kWh) are exceeded. Thus, power peak cut controls 1 and 2 are executed.

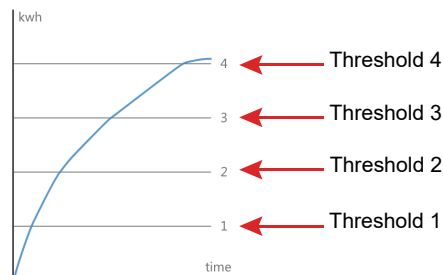



5 Tap [5-(1)]

6 Set the controls to execute if the thresholds that are set in step 4 are exceeded

- [6-(1)] Outdoor unit selection: Select a target outdoor unit
- [6-(2)] Control contents selection: Select the power peak cut control to execute if the threshold is exceeded

NOTE

- You can set power peak cut controls with seven stages from 100% (no restriction) to 0% (operation stop).
- You can set them for each of the outdoor units connected to the Unit.
- Before setting thresholds for outdoor units, initial settings are required. For details, contact service personnel.

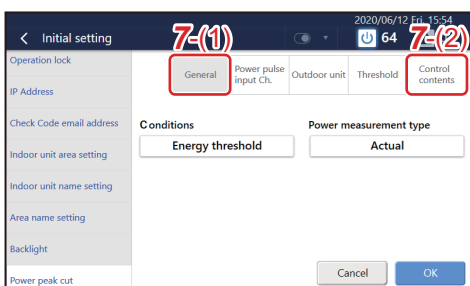

7 Tap [7-(1)] and tap [OK]

NOTE

Tap [7-(2)] to check the setting contents.

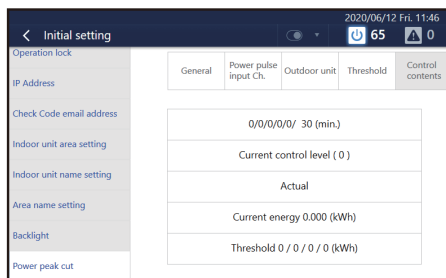

Set Peak cut signal reception

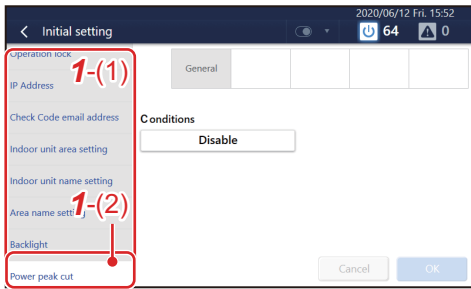

1 In [1-(1)], tap [1-(2)]

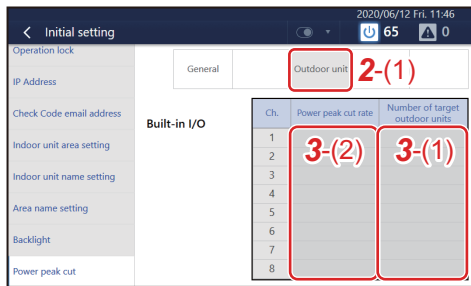

2 Tap [2-(1)]

3 Enter the power peak cut control to execute when the power peak cut signal is entered

- [3-(1)] Outdoor unit selection: Select a target outdoor unit
- [3-(2)] Control contents selection: Select the capacity limit to use when the power peak cut signal is entered

NOTE

- You can set them with seven stages from 100% (no restriction) to 0% (operation stop).
- You can set them for each of the outdoor units connected to the Unit.
- Before setting power peak cut controls, initial settings are required. For details, contact service personnel.

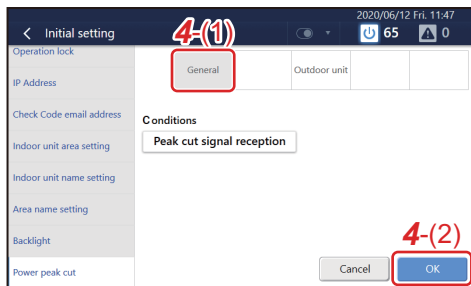

4 Tap [4-(1)], and tap [4-(2)]

A popup screen appears.

Confirm the information, and then tap [4-(3)].

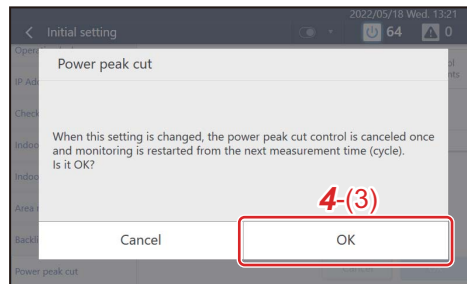

9 Remote Monitoring Using a PC

You can monitor and control the Unit by accessing it from a PC. This section explains the system diagram and the operating environment. For settings, etc., see "Settings for Remote Monitoring with a PC" (P.30).

NOTE

Some functions cannot be used from a PC. For details, please see "List by Lock Level/Level" (P.111).

Log in to Remote Control Software

NOTE

Up to 16 users can log in at the same time.

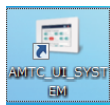

1 Double-click "AMTC_UI_****" on the desktop

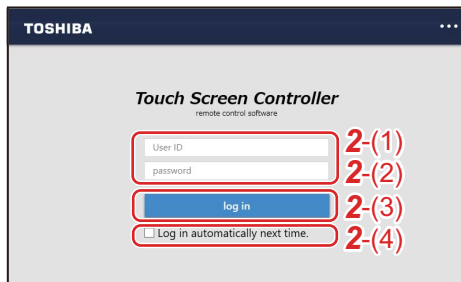

2 Enter [2-(1)] [2-(2)], then click [2-(3)]

User ID/password:

Use the user account set up in step **1** of "Unit settings" (P.30).

If the [2-(4)] check box is selected, login will be automatic from the next startup onwards.

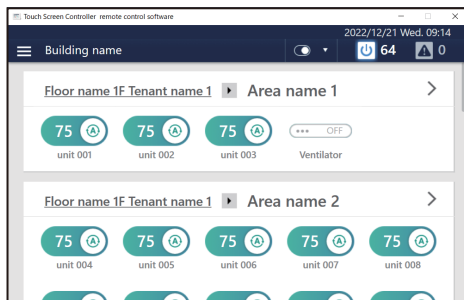

The home screen of the Remote Control Software is displayed.

Log out from Remote Control Software

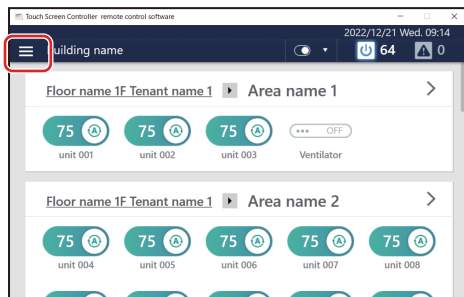

1 Click 

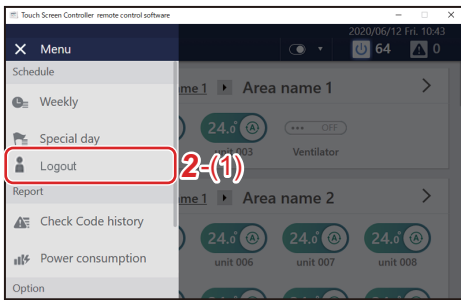

2 Click [2-(1)]

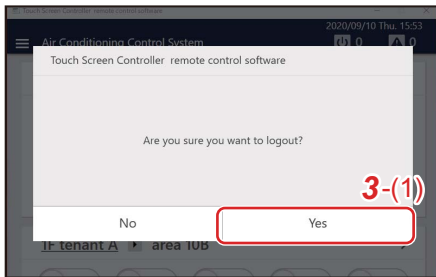

3 Click [3-(1)]
You are logged out from the Remote Control Software.

Exit Remote Control Software

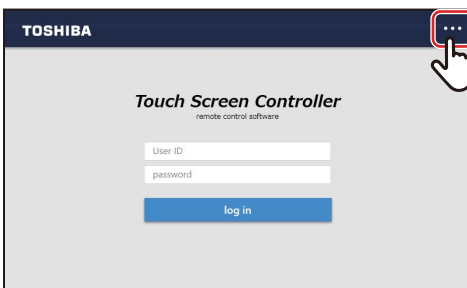

1 Tap [1-(1)]

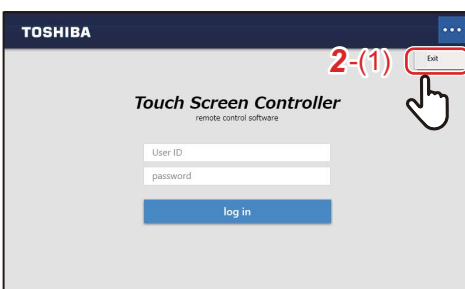

2 Tap [2-(1)]

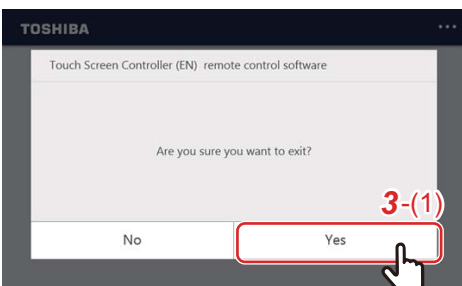

3 Tap [3-(1)]
Exit the Remote Control Software.

Configure the login settings for multiple system controllers



1 Double click [AMTC Launcher] on the desktop

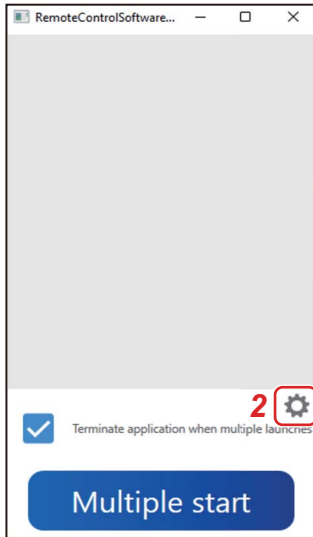

2 Click [2]

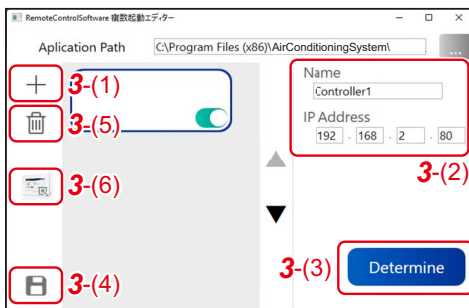

3
3.1 Click [3-(1)]

3.2 Set the name of the system controller in [3-(2)] Name and the IP address of the system controller in IP Address, and click the [3-(3)]

* To add multiple controllers, repeat Step **3.1** and **3.2** for each of the controllers.

3.3 Click [3-(4)] to close the window

NOTE

- Settings can be deleted by clicking the [3-(5)].
- A shortcut for the login settings can be created by clicking the [3-(6)].

Log in to multiple system controllers

1 Double click [AMTC Launcher] on the desktop

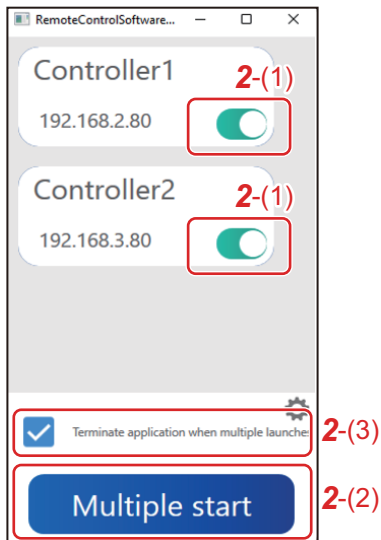

2 Turn the [2-(1)] of the system controller you wish to log in to ON, then click the [2-(2)]

The home screens of multiple Remote Control Software are displayed.

* If the [2-(3)] is selected, this window closes during startup.

10 Power Distribution

Power Distribution System Using the Energy Report Software 2 (PC Software)

In normal houses, a contract is made with the electric power company for each house, but in buildings such as offices and shops, a contract is made between the building owner and the electric power company, and the building owner pays the total electricity bill. Therefore, in some cases the building owner distributes the electricity fee that they paid in bulk to each tenant and invoices for a fee.

With Energy Report Software 2, you can distribute the electric power based on data such as the operating time of the air conditioner(s) and the ON/OFF equipment recorded by the Unit. In addition, you can easily summarize the operation results in a report format and calculate the billing amount.

Example report

Toshiba Building										
Air conditioner power distribution result Monthly report List										
Metering term										
Starting date		Jan/01/2019								
Ending date		Jan/31/2019								
Classification										
No.	System	Floor	Tenant	Area	Unit	Operating time[h]	Power [kWh]	Normal hours		A hou
								Operating time[h]	Power [kWh]	
1	ENR_test	Floor1	Tenant1	Area1	AC001	323.70	3,742.44	85.22	901.97	78.55
2	ENR_test	Floor1	Tenant1	Area1	AC002	331.55	3,582.63	83.13	893.77	79.85
3	ENR_test	Floor1	Tenant1	Area1	AC003	346.37	3,570.40	84.88	818.22	82.97
4	ENR_test	Floor2	Tenant2	Area2	AC004	339.97	3,670.81	83.42	886.18	84.68
5	ENR_test	Floor2	Tenant2	Area2	AC005	333.37	3,590.72	81.83	896.71	83.28
6	ENR_test	Floor3	Tenant3	Area3	AC006	331.55	3,582.63	83.13	893.77	79.85
7	ENR_test	Floor3	Tenant3	Area3	AC007	339.97	3,670.81	83.42	886.18	84.68
8	ENR_test	Floor3	Tenant3	Area3	AC008	333.37	3,590.72	81.83	896.71	83.28

CAUTION

- This system calculates the distribution of the power by load ratio estimated for each air conditioner. The result may differ from the actual power consumed. In addition, the result is not calculated based on the Measurement Act and cannot be used officially.
- This system correctly calculates and displays the amount of energy and the apportionment result only when the air conditioner, this controller, and the PC software are operating normally.
- When using this system, make sure that no error has occurred in the air conditioner, etc.

System diagram

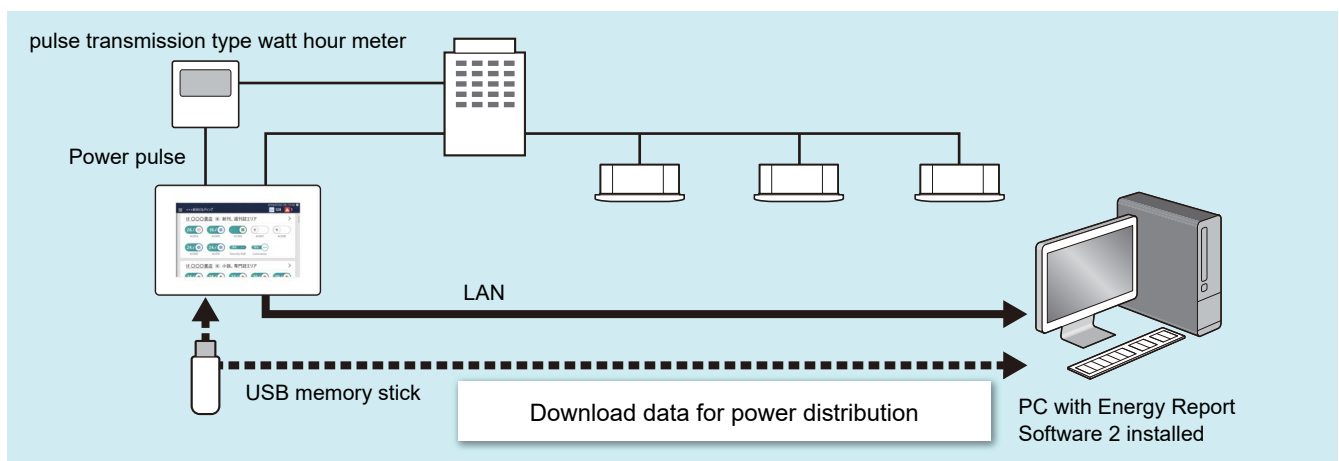

How to use the power distribution system

1 Download the data for power distribution

Save the data for power distribution to the PC using one of the following procedures.

1) Download by LAN connection

Download the data using the Energy Report Software 2.

2) Copy the data to a USB memory stick

Output the data to the USB memory stick using the Unit's [Output to USB memory] and import the data using the Energy Report Software 2.

2 Create monthly reports and daily reports

Create a monthly report or daily report from [Change display] - [Report] in the Energy Report Software 2.

3 From the [Monthly report] screen or the [Daily report] screen, click the month or day you want to display

4 Click the [Output] button

• NOTE

For details, refer to the Operating Instructions of the Energy Report Software 2.

11 Troubleshooting

Phenomenon	Question	Confirmation items
The LCD does not display.	Is the power turned on?	Check that the power is not turned off by the breaker or the like. There is a green LED at the lower rear of the main unit and a green LED on the AC adapter that indicate that power is being supplied. Check that the wiring of the power outlet and AC adapter is not disconnected. There is a green LED at the lower rear of the main unit and a green LED on the AC adapter that indicate that power is being supplied.
	Has the backlight gone out?	The LCD turns off when there is no operation for a certain period of time. Touch the touch panel to turn on. The brightness and display time can be changed using [Backlight].
	Is the backlight brightness dark?	Adjust the brightness using [Backlight].
The operated air conditioner does not run.	Does the operated air conditioner match the actual air conditioner?	Operate another air conditioner and check if the actual air conditioner operates.
	Has a check code been detected?	The air conditioner will not operate when a check code has been detected. Erase the check code.
	Are you operating with the local remote control?	Even if the air conditioner is run with this Unit, if it is stopped afterwards with the local remote control, it will stop. The latter operation of this Unit or the local remote control overrides the former.
	Is the air conditioner stopped due to the schedule setting of the local remote control or the like?	Even if the air conditioner is run with this Unit, if it is stopped afterwards with the local remote control schedule, it will stop. The latter operation of this Unit or the local remote control overrides the former.
	Are you operating with the PC app "Remote Control Software"?	Even if the air conditioner is run with this Unit, if it is stopped afterwards with the PC app "Remote Control Software", it will stop. The latter operation of this Unit or the "Remote Control Software" overrides the former.
I want to turn off the power.	From [Menu], turn off the power.	Select [Menu]-[Functions]-[shut down].
I want to reboot.	Reboot from the menu.	Select [Menu]-[Functions]-[System reboot].
The air conditioner settings change arbitrarily.	Are you operating with the local remote control?	Even if the air conditioner is run with this Unit, if it is stopped afterwards with the local remote control, it will stop. The latter operation of this Unit or the local remote control overrides the former.
	Is the air conditioner stopped due to the schedule setting of the local remote control or the like?	Even if the air conditioner is run with this Unit, if it is stopped afterwards with the local remote control schedule, it will stop. The latter operation of this Unit or the local remote control overrides the former.
	Have you applied settings such as stop using an external input signal?	When stop, etc. is set by an external input signal using the external interlocking function, the air conditioner stops automatically when a signal is input.
	Are you operating with the PC app "Remote Control Software"?	Even if the air conditioner is run with this Unit, if it is stopped afterwards with the PC app "Remote Control Software", it will stop. The latter operation of this Unit or the "Remote Control Software" overrides the former.
The schedule does not work.	Is the schedule disabled?	Please confirm the Scheduler Operation settings.
	Does the scheduled air conditioner match the actual air conditioner?	Operate another air conditioner and check if the actual air conditioner operates.
	Is a Special day schedule set?	If a day is set in both the Weekly schedule and a Special day schedule, the Special day schedule will apply for that day.
The air conditioner doesn't cool. The air conditioner doesn't heat.	Is demand control turned on?	Demand control suppresses the capability of the outdoor unit in order to reduce power consumption. Therefore, it may take time to reach the set temperature.
	Is the forced thermo OFF control turned on?	Forced thermo OFF is a control to stop the operation of the outdoor unit. Therefore, the indoor unit acts as a fan.
	Is the power saving control turned on?	Power saving suppresses the capability of the outdoor unit. Therefore, it may take time to reach the set temperature.

Phenomenon	Question	Confirmation items
The LCD does not turn off.	Has a check code been detected?	The LCD will still be on when a check code has been detected. Erase the check code.
Sometimes the LCD becomes black for a moment.	The LCD's antistatic control is working.	Temporarily stop the LCD periodically to prevent LCD burn-in. Not a malfunction.
The setting displayed on the local remote control does not match the setting displayed on this Unit.	Does the operated air conditioner match the actual air conditioner?	Operate another air conditioner and check if the actual air conditioner operates.
I would like to frequently change detailed settings such as the set temperature and operation mode for all air conditioners.	Only "ON" and "OFF" can operate all air conditioners at once.	You can set the set temperature and operation mode, etc. for all air conditioners group by group. Please group the air conditioners.
When local remote control operation is prohibited, if there is a power failure, the local remote control prohibited status will be cancelled when the power returns.	-	Ask service personnel if you want to continue the local remote control prohibited status after returning from a power failure.
FILTER information can be reset even when the FILTER sign is not displayed.	The FILTER sign lights up depending on the accumulated operation time.	As the operation time accumulates, the FILTER sign lights up when the preset operation time is reached. The FILTER sign information can be reset to clear the accumulated time for cases such as when FILTER cleaning is carried out before the FILTER sign turns on.
I want to check the software version.	Reboot from the Information menu.	The version is displayed under [Menu] - [Information].
The webpage of the Controller is not displayed.	Is the power to the System Controller on?	If the power to the System Controller is not on, you cannot connect to the webpage. Confirm if the power is on.
	Is the LAN cable connected?	The webpage is not displayed unless the PC and the LAN of this Unit are connected. Check the LAN cable connection and network settings.
	Have you set the IP address?	You cannot connect to the Unit unless the IP address of the PC is set. For details, see P.31.
	Do you use a proxy server?	If the setting is such that a proxy server is used, exclude the IP address of the System Controller.
Reboot from time to time.	Please check for noise and the power supply status.	The main unit may restart if noise in the surroundings or an unstable power supply cause the operation of the software to be unstable. Please check the surrounding environment.
I cannot start the Remote Control Software.	Is "Error 1001" displayed?	Please download .Net Framework 4.8 from the download website of this software and install it.
	Is the LAN cable connected?	This software will not start unless the PC and the LAN of this Unit are connected. Check the LAN cable connection and network settings.
	Is the IP address of the access destination set to the IP address of the controller main unit?	The IP address (or server name) to be entered during installation is the IP address of the controller main unit. It is not the IP address of the PC. If it is incorrect, please do the following and then reinstall. 1. Uninstall the application 2. Delete the install destination directory 3. Delete the desktop and start menu shortcuts
	Is the operating system of your computer Windows 10 or Windows 11?	The supported operating systems are Windows 10 and Windows 11. The software may not operate correctly when installed on a PC with a different OS.

Phenomenon	Question	Confirmation items
I cannot log in to the Remote Control Software.	Have you logged in as the same user from another PC?	Each user can log in from only one PC at the same time.
	Is the Windows display style set to classic style?	Please select a display style other than classic style. You can change the display style from [Start] - [Control Panel] - [Appearance and Personalization] - [Change the theme]. The supported operating systems of this software are Windows 10 and Windows 11.
I cannot log in to Remote Control Software from another PC after the LAN is disconnected.	Have you logged in with the same user ID?	You must log in again from a PC with the LAN disconnected and log out normally.
	Have you accessed the software from more than 8 PCs?	Up to 8 PCs can be accessed at the same time. The software may not operate correctly if you connect to more than 9 PCs.
	Did you assign the PC's IP address using a DHCP server?	This Unit judges whether it is accessed from the same PC using the IP address. If the PC address is changed partway through by the DHCP server, you may not be able to log in again after LAN disconnection. Please set the PC that accesses this Unit to a fixed IP or reboot the Unit and erase the login information.
The language does not switch with the Remote Control Software.	Does the login user for the Windows being used have write permission for the Remote Control Software storage location?	Please allow write permission below the folder where Remote Control Software is saved (initial setting: C:\Program Files\AirConditioningSystem). Right-click on the AirConditioningSystem folder, select the [Properties] - [Security] Name, click the "Edit" button and check [Allow] for [Full control] under different settings.
The schedule setting changes have not been reflected.	Are you trying to change the schedule settings on both the Remote Control Software and the main unit?	To change the schedule settings, please set only one of either the main unit or the Remote Control Software.
I would like to use the software with other centralized controllers.	Centralized controllers that can be used together within the same network.	It is possible to use up to 8 units together with all centralized controllers including this Unit. Ask service personnel to use them in combination.
I want to use multiple units in combination.	Number of units that can be used in combination in the same network.	It is possible to use up to 8 units together with all centralized controllers including this Unit. Ask service personnel to use them in combination.
The LCD sometimes turns black for a moment.	The LCD's antistatic control is working.	This is not a malfunction. The LCD may turn black temporarily to remove static electricity.
The multi outdoor unit's option board control does not work.	Do you want to use the multi outdoor unit's option board?	When the centralized controller is connected, the functions of the outdoor unit's option board become ineffective. Only one of the centralized controller and the outdoor unit's option board can be used.
The Unit does turn ON/OFF even though the operation interlock signal/stop interlock signal is input.	Has the interlock signal been input from the time of activation?	Since the interlock signal confirms the state by detecting the rising edge and falling edge, if the interlock signal is input from the time of activation, interlock control will not be performed. Please set so that the interlock signal turns OFF at the time of activation.
When the external device is repeatedly ON/OFF, the ON/OFF are repeated for a while after the operation is stopped.	Do you control and monitor external devices by connecting a digital input / output interface?	To control the ON/OFF with an external device, wait at least 15 seconds for the next operation after one operation. Alternatively, change the setting to control and monitor using the DI / DO of the controller instead of the digital I / O interface connection.
	Do you have alarm monitoring settings for External Units?	If the alarm monitoring of External Unit is not set, the alarm cannot be detected.
S33 (central controller addresses duplicated) has occurred.	Are LINK1 (Uh) and LINK2 (Uh) connected to the same wires?	LINK1 (Uh) and LINK2 (Uh) cannot be connected to the same wires.
	Is the Central Controller ID the same as another Central Control Device that is connected to the same LINK?	Change them so that the Central Controller IDs (addresses) of the Central Control Devices, not just the Touch screen controllers, connected to the same LINK, are not the same.

12 Useful Information

The following cases are not faults with the Unit.

Problem	Cause
When an air conditioner is stopped, its operation status is displayed on the LCD display part of the Touch screen controller.	This is because even when an air conditioner is stopped, you can set its operation from the Touch screen controller.
The display does not switch even if you operate the Touch screen controller.	<ul style="list-style-type: none"> • The function is not provided by the air conditioner. • There may be an error in the operation method. Please check the operation explanation of the function. • This is because switching of HEAT and COOL in the operation mode is prohibited.
It is not set even when operating the Touch screen controller.	

Please check the following before requesting service.

Problem	Cause	Solution
The air conditioner does not operate even when I press the Run/Stop switch on the Touch screen controller.	Has a power outage occurred?	If the LCD of the Touch screen controller does not display, press the ON/OFF button of the Touch screen controller again after energizing the controller.
On the LCD display part of the Touch screen controller  (Abnormality) and the check code S01 is displayed.		After restoring power to the air conditioner, the display will disappear after waiting a few minutes.
The check lamp of the Touch screen controller lights up.	Is the air conditioner protection device operating?	Please see the air conditioner owner's manual and check the operation.

If you have investigated the above and there is still an abnormality, please contact the dealer from whom you purchased the Unit with the part number and problem.

Under no circumstances conduct repairs by yourself. Doing so is dangerous.

Moreover, if the LCD display part of the Touch screen controller displays  (Abnormality) and a check code, please also inform the dealer of these items.

13 Appendix

Specifications

Detailed specifications

Power supply	AC 120 V 60 Hz
Consumed current	1.17 A
Operating temperature/ humidity range	32 to 104°F(0°C to 40°C), 10% to 90% RH (no dew condensation)
Dimensions (mm)	H5.35"×W8.07"×D0.39" (H136 mm×W205 mm×D10 mm)(+3.15" (+80 mm)) (Embedded dimensions shown in parenthesis)
Mass	2.95 lb (1.34 kg) (Touch Screen Controller) 0.99 lb (0.45 kg) (power adapter)
LCD	Type 7 TFT liquid crystal, 800×480, 167,000 colours
Touch Screen	Projection-capacitive type
Communication ports	· RS-485 port ×1 (for connecting four digital I/O interfaces and four watt hour meter interfaces) · LAN port ×1 (for connecting PC)
USB port	USB memory stick connection port ×2
External contact input	8 inputs
External contact output	4 inputs
Included PC software (*1) (Requires a separate PC (*3))	· Remote Control Software · Energy Report Software 2 · Section Configuration Software

*1 You can download the owner's manual and installer for "Section Configuration Software" from inside the controller.
After setting the IP address of the computer (P.31), use the customer's web browser to access the following URL.
<http://192.168.2.80/touchscreencontroller/EN-UL/download.html>^{*2}

*2 Input the value set in "Set the IP address of the Touch screen controller" (P.89) in place of "192.168.2.80".

*3 Conditions for PC connection (operating environment)
OS: Windows 10, Windows 11
LAN port: 10BASE-T or 100BASE-TX wired LAN port
Other: mouse/keyboard, printer (if printing is required)

Function list

Key Features		
Control	ON/OFF	
	Mode	
	Set temp.	
	Fan speed	
	Wind direction	
	Lock setting of remote control	
	Ventilation → ON/OFF	
	Ventilation → Mode	
	Ventilation → Fan speed	
	Night operation	
	Filter sign reset	
	Soft Cooling	
	Energy saving ratio [%]	
	Saving operation	
	Forced Thermo OFF	
	Return Back	
	Eco Temperature Shift	
	Set temp. range limit	
	Monitoring	ON/OFF
		Mode
Set temp.		
Fan speed		
Wind direction		
Lock setting of remote control		
Ventilation → ON/OFF		
Ventilation → Mode		
Ventilation → Fan speed		
Soft Cooling		
Energy saving ratio [%]		
Eco Temperature Shift		
Set temp. range limit		
Outdoor temp.		
Power Level		
Return Back		
Power peak cut		
Filter Sign		
Schedule	Setting unit (Per unit)	
	Setting unit: Weekly schedule (per day of the week)	
	Setting unit: Special day schedule (per date)	
	Setting time (00:00 to 23:59)	
	Setting content	ON/OFF
		Mode
		Set temp.
		Local remote controller operation lock/unlock
		Return Back
		Night operation
		Energy saving ratio [%]
Ventilation operation		
Vent. Mode		
Maximum number of schedules per day 64		

Key Features			
External input	Inputs	Main unit	8 inputs
		DIO interface	8 inputs x 4 units
	Functions	Power pulse measurement	
		Demand Interlocking	
		Locking Interlocking	
		Stop Interlocking	
		Operation Interlocking	
		For external device ON/OFF indication	
External output	Outputs	Main unit	4 outputs
		DIO interface	4 outputs x 4 units
	Functions	Air conditioner check code output	
		Operation output	
		System Controller check code output	
		Operation output to external device	

Check Code	Check Code Names
S01	Communication error between air conditioner and BMS
S02	BMS-IFLSV Communication error
S03	Group terminal unit error
S04	BMS-IFWH Communication error
S06	BMS-IFWH Communication error
S07	BMS-IFDD Communication error
S08	Communication error
S09	Communication error
S12	Other error
S14	Start failure
S15	File access error
S16	IP address setup error
S17	File load error
S18	BMS-IFWH initialization communication incomplete
S19	BMS-IFDD initialization communication incomplete
S20	Initialization between air conditioner and BMS is not completed
S21	Mail transmission error
S22	Internal communication error
S23	Setting file read error
S25	Schedule file read error
S26	Schedule file write error
S27	Daily report/Monthly report file read error
S28	Daily report/Monthly report file write error
S29	Application error
S30	System error
S32	Alarm activation
S33	System controller address duplication error
S36	CO ₂ concentration threshold exceeded

List by Lock Level/Level

Refer to the following table for the functional differences depending on the operation of the main Unit and remote operation, the level of the operation lock of the main Unit and the level of the user account.

(○: Full functional operation △: Partially restricted –: Cannot be used)

Item		Unit Operation			Remote Operation		
		Operation Lock None	Operation Lock - Level 1	Operation Lock - Level 2	Administrators	Power Users	Guests
Home screen		○	○	△	○	○	△
List screen		○	○	△	○	○	△
Layout screen		○	○	△	○	○	△
Batch ON/OFF screen		○	○	△	○	○	△
Check Code screen		○	○	△	○	○	△
Group screen	[CONTROL] tab	○	–	–	○	○	–
	[SCHEDULE] tab	○	–	–	○	–	–
	[GRAPH] tab	○	○	–	○	○	–
Individual control screen	[CONTROL] tab	○	○	–	○	○	–
	[SCHEDULE] tab	○	–	–	○	–	–
	[GRAPH] tab	○	○	–	○	○	–

Item			Unit Operation			Remote Operation			
			Operation Lock None	Operation Lock - Level 1	Operation Lock - Level 2	Admini strators	Power Users	Guests	
Menu	Schedule	[Weekly] tab	○	–	–	○	–	–	
		[Special day] tab	○	–	–	○	–	–	
	Report	Check Code history	○	○	○	○	○	○	
		Power consumption	○	○	○	○	○	○	
	Option	Operation Lock		○	○	○	○	○	○
		Functions	Release power peak cut	○	–	–	○	–	–
			Power peak cut schedule	○	–	–	○	–	–
			Operation mode restriction	○	–	–	○	–	–
			Scheduler Operation	○	–	–	○	–	–
			Output to USB Memory	○	–	–	–	–	–
			System reboot	○	–	–	○	–	–
			Shut down	○	–	–	○	–	–
		Initial setting	Display	○	–	–	○	–	–
			Clock and calendar	○	–	–	○	–	–
			Icon	○	–	–	○	–	–
			Theme	○	–	–	○	–	–
			User Account	○	–	–	–	–	–
			Operation Lock	○	–	–	○	–	–
			IP Address	○	–	–	–	–	–
			Check Code email address	○	–	–	–	–	–
			Indoor unit area setting	○	–	–	–	–	–
			Indoor unit name setting	○	–	–	–	–	–
			Area name setting	○	–	–	–	–	–
		Backlight	○	–	–	–	–	–	
	Power peak cut	○	–	–	–	–	–		
	User's manual		○	○	○	–	–	–	
	Information screen		○	○	○	○	○	○	
Logout		–	–	–	○	○	○		

14 Warranty and After-Sales Service

About the Warranty

- The warranty period is one year from date of purchase.

About After-Sales Service

- Please check "11. Troubleshooting" (P.104) before requesting a repair. If this does not solve the problem, immediately shut off the power supply and contact us.
- Please inform us of the following when requesting a repair.
 - **Customer name**
 - **Address, phone number**
 - **Product model name and serial number**
 - **Installation date**
 - **Failure status (as much detail as possible)**

Contact for after-sales service

For after-sales service, please contact here.

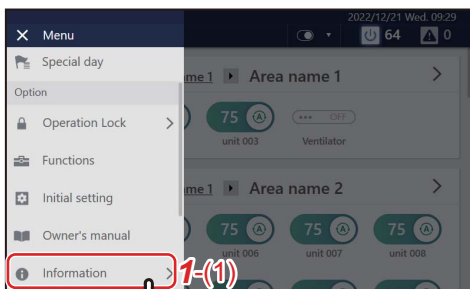

- 1 Tap , then tap [1-(1)]
The contact information is displayed.

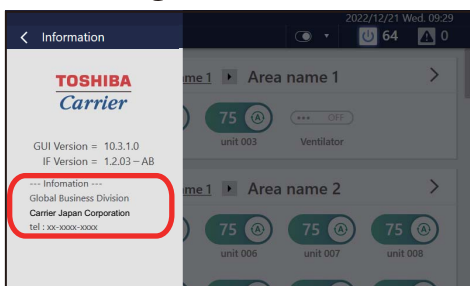

OSS License

This product contains licensed software or software whose copyright is owned by a third party according to the following.

OpenSSH

This file is part of the OpenSSH software.

The licences which components of this software fall under are as follows. First, we will summarize and say that all components are under a BSD licence, or a licence more free than that.

OpenSSH contains no GPL code.

1)

- * Copyright (c) 1995 Tatu Ylonen <ylo@cs.hut.fi>, Espoo, Finland
- * All rights reserved
- *
- * As far as I am concerned, the code I have written for this software
- * can be used freely for any purpose. Any derived versions of this
- * software must be clearly marked as such, and if the derived work is
- * incompatible with the protocol description in the RFC file, it must be
- * called by a name other than "ssh" or "Secure Shell".

[Tatu continues]

- * However, I am not implying to give any licenses to any patents or
- * copyrights held by third parties, and the software includes parts that
- * are not under my direct control. As far as I know, all included
- * source code is used in accordance with the relevant license agreements
- * and can be used freely for any purpose (the GNU license being the most
- * restrictive); see below for details.

[However, none of that term is relevant at this point in time. All of these restrictively licenced software components which he talks about have been removed from OpenSSH, i.e.,

- RSA is no longer included, found in the OpenSSL library
- IDEA is no longer included, its use is deprecated
- DES is now external, in the OpenSSL library
- GMP is no longer used, and instead we call BN code from OpenSSL
- Zlib is now external, in a library
- The make-ssh-known-hosts script is no longer included
- TSS has been removed
- MD5 is now external, in the OpenSSL library
- RC4 support has been replaced with ARC4 support from OpenSSL
- Blowfish is now external, in the OpenSSL library

[The licence continues]

Note that any information and cryptographic algorithms used in this software are publicly available on the Internet and at any major bookstore, scientific library, and patent office worldwide. More information can be found e.g. at "<http://www.cs.hut.fi/crypto>".

The legal status of this program is some combination of all these permissions and restrictions. Use only at your own responsibility. You will be responsible for any legal consequences yourself; I am not making any claims whether possessing or using this is legal or not in

your country, and I am not taking any responsibility on your behalf.

NO WARRANTY

BECAUSE THE PROGRAM IS LICENSED FREE OF CHARGE, THERE IS NO WARRANTY FOR THE PROGRAM, TO THE EXTENT PERMITTED BY APPLICABLE LAW. EXCEPT WHEN OTHERWISE STATED IN WRITING THE COPYRIGHT HOLDERS AND/OR OTHER PARTIES PROVIDE THE PROGRAM "AS IS" WITHOUT WARRANTY OF ANY KIND, EITHER EXPRESSED OR IMPLIED, INCLUDING, BUT NOT LIMITED TO, THE IMPLIED WARRANTIES OF MERCHANTABILITY AND FITNESS FOR A PARTICULAR PURPOSE. THE ENTIRE RISK AS TO THE QUALITY AND PERFORMANCE OF THE PROGRAM IS WITH YOU. SHOULD THE PROGRAM PROVE DEFECTIVE, YOU ASSUME THE COST OF ALL NECESSARY SERVICING, REPAIR OR CORRECTION.

IN NO EVENT UNLESS REQUIRED BY APPLICABLE LAW OR AGREED TO IN WRITING WILL ANY COPYRIGHT HOLDER, OR ANY OTHER PARTY WHO MAY MODIFY AND/OR REDISTRIBUTE THE PROGRAM AS PERMITTED ABOVE, BE LIABLE TO YOU FOR DAMAGES INCLUDING ANY GENERAL, SPECIAL, INCIDENTAL OR CONSEQUENTIAL DAMAGES ARISING OUT OF THE USE OR INABILITY TO USE THE PROGRAM (INCLUDING BUT NOT LIMITED TO LOSS OF DATA OR DATA BEING RENDERED INACCURATE OR LOSSES SUSTAINED BY YOU OR THIRD PARTIES OR A FAILURE OF THE PROGRAM TO OPERATE WITH ANY OTHER PROGRAMS), EVEN IF SUCH HOLDER OR OTHER PARTY HAS BEEN ADVISED OF THE POSSIBILITY OF SUCH DAMAGES.

3)

ssh-keyscan was contributed by David Mazieres under a BSD-style license.

* Copyright 1995, 1996 by David Mazieres <dm@lcs.mit.edu>.

*

* Modification and redistribution in source and binary forms is permitted provided that due credit is given to the author and the OpenBSD project by leaving this copyright notice intact.

4)

The Rijndael implementation by Vincent Rijmen, Antoon Bosselaers and Paulo Barreto is in the public domain and distributed with the following license:

* @version 3.0 (December 2000)

*

* Optimised ANSI C code for the Rijndael cipher (now AES)

*

* @author Vincent Rijmen <vincent.rijmen@esat.kuleuven.ac.be>

* @author Antoon Bosselaers <antoon.bosselaers@esat.kuleuven.ac.be>

* @author Paulo Barreto <paulo.barreto@terra.com.br>

*

* This code is hereby placed in the public domain.

*

* THIS SOFTWARE IS PROVIDED BY THE AUTHORS "AS IS" AND ANY EXPRESS OR IMPLIED WARRANTIES, INCLUDING, BUT NOT LIMITED TO, THE IMPLIED WARRANTIES OF MERCHANTABILITY AND FITNESS FOR A PARTICULAR PURPOSE ARE DISCLAIMED. IN NO EVENT SHALL THE AUTHORS OR CONTRIBUTORS BE

* LIABLE FOR ANY DIRECT, INDIRECT, INCIDENTAL, SPECIAL, EXEMPLARY, OR
 * CONSEQUENTIAL DAMAGES (INCLUDING, BUT NOT LIMITED TO, PROCUREMENT OF
 * SUBSTITUTE GOODS OR SERVICES; LOSS OF USE, DATA, OR PROFITS; OR
 * BUSINESS INTERRUPTION) HOWEVER CAUSED AND ON ANY THEORY OF LIABILITY,
 * WHETHER IN CONTRACT, STRICT LIABILITY, OR TORT (INCLUDING NEGLIGENCE
 * OR OTHERWISE) ARISING IN ANY WAY OUT OF THE USE OF THIS SOFTWARE,
 * EVEN IF ADVISED OF THE POSSIBILITY OF SUCH DAMAGE.

5)

One component of the ssh source code is under a 3-clause BSD license, held by the University of California, since we pulled these parts from original Berkeley code.

* Copyright (c) 1983, 1990, 1992, 1993, 1995
 * The Regents of the University of California. All rights reserved.
 *
 * Redistribution and use in source and binary forms, with or without
 * modification, are permitted provided that the following conditions
 * are met:
 * 1. Redistributions of source code must retain the above copyright
 * notice, this list of conditions and the following disclaimer.
 * 2. Redistributions in binary form must reproduce the above copyright
 * notice, this list of conditions and the following disclaimer in the
 * documentation and/or other materials provided with the distribution.
 * 3. Neither the name of the University nor the names of its contributors
 * may be used to endorse or promote products derived from this software
 * without specific prior written permission.
 *
 * THIS SOFTWARE IS PROVIDED BY THE REGENTS AND CONTRIBUTORS ``AS IS'' AND
 * ANY EXPRESS OR IMPLIED WARRANTIES, INCLUDING, BUT NOT LIMITED TO, THE
 * IMPLIED WARRANTIES OF MERCHANTABILITY AND FITNESS FOR A PARTICULAR PURPOSE
 * ARE DISCLAIMED. IN NO EVENT SHALL THE REGENTS OR CONTRIBUTORS BE LIABLE
 * FOR ANY DIRECT, INDIRECT, INCIDENTAL, SPECIAL, EXEMPLARY, OR CONSEQUENTIAL
 * DAMAGES (INCLUDING, BUT NOT LIMITED TO, PROCUREMENT OF SUBSTITUTE GOODS
 * OR SERVICES; LOSS OF USE, DATA, OR PROFITS; OR BUSINESS INTERRUPTION)
 * HOWEVER CAUSED AND ON ANY THEORY OF LIABILITY, WHETHER IN CONTRACT, STRICT
 * LIABILITY, OR TORT (INCLUDING NEGLIGENCE OR OTHERWISE) ARISING IN ANY WAY
 * OUT OF THE USE OF THIS SOFTWARE, EVEN IF ADVISED OF THE POSSIBILITY OF
 * SUCH DAMAGE.

6)

Remaining components of the software are provided under a standard 2-term BSD licence with the following names as copyright holders:

Markus Friedl
 Theo de Raadt
 Niels Provos
 Dug Song
 Aaron Campbell
 Damien Miller
 Kevin Steves
 Daniel Kouril
 Wesley Griffin
 Per Allansson

Nils Nordman
Simon Wilkinson

- * Redistribution and use in source and binary forms, with or without
- * modification, are permitted provided that the following conditions
- * are met:
- * 1. Redistributions of source code must retain the above copyright
- * notice, this list of conditions and the following disclaimer.
- * 2. Redistributions in binary form must reproduce the above copyright
- * notice, this list of conditions and the following disclaimer in the
- * documentation and/or other materials provided with the distribution.
- *
- * THIS SOFTWARE IS PROVIDED BY THE AUTHOR ``AS IS" AND ANY EXPRESS OR
- * IMPLIED WARRANTIES, INCLUDING, BUT NOT LIMITED TO, THE IMPLIED WARRANTIES
- * OF MERCHANTABILITY AND FITNESS FOR A PARTICULAR PURPOSE ARE DISCLAIMED.
- * IN NO EVENT SHALL THE AUTHOR BE LIABLE FOR ANY DIRECT, INDIRECT,
- * INCIDENTAL, SPECIAL, EXEMPLARY, OR CONSEQUENTIAL DAMAGES (INCLUDING, BUT
- * NOT LIMITED TO, PROCUREMENT OF SUBSTITUTE GOODS OR SERVICES; LOSS OF USE
- * DATA, OR PROFITS; OR BUSINESS INTERRUPTION) HOWEVER CAUSED AND ON ANY
- * THEORY OF LIABILITY, WHETHER IN CONTRACT, STRICT LIABILITY, OR TORT
- * (INCLUDING NEGLIGENCE OR OTHERWISE) ARISING IN ANY WAY OUT OF THE USE OF
- * THIS SOFTWARE, EVEN IF ADVISED OF THE POSSIBILITY OF SUCH DAMAGE.

\$OpenBSD: LICENCE,v 1.20 2017/04/30 23:26:16 djm Exp \$

JamesNK_Newtonsoft.Json

The MIT License (MIT)

Copyright (c) 2007 James Newton-King

Permission is hereby granted, free of charge, to any person obtaining a copy of this software and associated documentation files (the "Software"), to deal in the Software without restriction, including without limitation the rights to use, copy, modify, merge, publish, distribute, sublicense, and/or sell copies of the Software, and to permit persons to whom the Software is furnished to do so, subject to the following conditions:

The above copyright notice and this permission notice shall be included in all copies or substantial portions of the Software.

THE SOFTWARE IS PROVIDED "AS IS", WITHOUT WARRANTY OF ANY KIND, EXPRESS OR IMPLIED, INCLUDING BUT NOT LIMITED TO THE WARRANTIES OF MERCHANTABILITY, FITNESS FOR A PARTICULAR PURPOSE AND NONINFRINGEMENT. IN NO EVENT SHALL THE AUTHORS OR COPYRIGHT HOLDERS BE LIABLE FOR ANY CLAIM, DAMAGES OR OTHER LIABILITY, WHETHER IN AN ACTION OF CONTRACT, TORT OR OTHERWISE, ARISING FROM, OUT OF OR IN CONNECTION WITH THE SOFTWARE OR THE USE OR OTHER DEALINGS IN THE SOFTWARE.

DeveloperSharp

MIT License

Copyright (c) <year> <copyright holders>

Permission is hereby granted, free of charge, to any person obtaining a copy of this software and associated documentation files (the "Software"), to deal in the Software without restriction, including without limitation the rights to use, copy, modify, merge, publish, distribute, sublicense, and/or sell copies of the Software, and to permit persons to whom the Software is furnished to do so, subject to the following conditions:

The above copyright notice and this permission notice (including the next paragraph) shall be included in all copies or substantial portions of the Software.

THE SOFTWARE IS PROVIDED "AS IS", WITHOUT WARRANTY OF ANY KIND, EXPRESS OR IMPLIED, INCLUDING BUT NOT LIMITED TO THE WARRANTIES OF MERCHANTABILITY, FITNESS FOR A PARTICULAR PURPOSE AND NONINFRINGEMENT. IN NO EVENT SHALL THE AUTHORS OR COPYRIGHT HOLDERS BE LIABLE FOR ANY CLAIM, DAMAGES OR OTHER LIABILITY, WHETHER IN AN ACTION OF CONTRACT, TORT OR OTHERWISE, ARISING FROM, OUT OF OR IN CONNECTION WITH THE SOFTWARE OR THE USE OR OTHER DEALINGS IN THE SOFTWARE.

Entity Framework

Apache License
Version 2.0, January 2004
<http://www.apache.org/licenses/>

TERMS AND CONDITIONS FOR USE, REPRODUCTION, AND DISTRIBUTION

1. Definitions.

"License" shall mean the terms and conditions for use, reproduction, and distribution as defined by Sections 1 through 9 of this document.

"Licensor" shall mean the copyright owner or entity authorized by the copyright owner that is granting the License.

"Legal Entity" shall mean the union of the acting entity and all other entities that control, are controlled by, or are under common

control with that entity. For the purposes of this definition, "control" means (i) the power, direct or indirect, to cause the direction or management of such entity, whether by contract or otherwise, or (ii) ownership of fifty percent (50%) or more of the outstanding shares, or (iii) beneficial ownership of such entity.

"You" (or "Your") shall mean an individual or Legal Entity exercising permissions granted by this License.

"Source" form shall mean the preferred form for making modifications, including but not limited to software source code, documentation source, and configuration files.

"Object" form shall mean any form resulting from mechanical transformation or translation of a Source form, including but not limited to compiled object code, generated documentation, and conversions to other media types.

"Work" shall mean the work of authorship, whether in Source or Object form, made available under the License, as indicated by a copyright notice that is included in or attached to the work (an example is provided in the Appendix below).

"Derivative Works" shall mean any work, whether in Source or Object form, that is based on (or derived from) the Work and for which the editorial revisions, annotations, elaborations, or other modifications represent, as a whole, an original work of authorship. For the purposes of this License, Derivative Works shall not include works that remain separable from, or merely link (or bind by name) to the interfaces of, the Work and Derivative Works thereof.

"Contribution" shall mean any work of authorship, including the original version of the Work and any modifications or additions to that Work or Derivative Works thereof, that is intentionally submitted to Licensor for inclusion in the Work by the copyright owner or by an individual or Legal Entity authorized to submit on behalf of the copyright owner. For the purposes of this definition, "submitted" means any form of electronic, verbal, or written communication sent to the Licensor or its representatives, including but not limited to communication on electronic mailing lists, source code control systems, and issue tracking systems that are managed by, or on behalf of, the Licensor for the purpose of discussing and improving the Work, but excluding communication that is conspicuously marked or otherwise designated in writing by the copyright owner as "Not a Contribution."

"Contributor" shall mean Licensor and any individual or Legal Entity on behalf of whom a Contribution has been received by Licensor and subsequently incorporated within the Work.

2. Grant of Copyright License. Subject to the terms and conditions of this License, each Contributor hereby grants to You a perpetual, worldwide, non-exclusive, no-charge, royalty-free, irrevocable copyright license to reproduce, prepare Derivative Works of, publicly display, publicly perform, sublicense, and distribute the Work and such Derivative Works in Source or Object form.
3. Grant of Patent License. Subject to the terms and conditions of this License, each Contributor hereby grants to You a perpetual, worldwide, non-exclusive, no-charge, royalty-free, irrevocable (except as stated in this section) patent license to make, have made, use, offer to sell, sell, import, and otherwise transfer the Work, where such license applies only to those patent claims licensable by such Contributor that are necessarily infringed by their Contribution(s) alone or by combination of their Contribution(s)

with the Work to which such Contribution(s) was submitted. If You institute patent litigation against any entity (including a cross-claim or counterclaim in a lawsuit) alleging that the Work or a Contribution incorporated within the Work constitutes direct or contributory patent infringement, then any patent licenses granted to You under this License for that Work shall terminate as of the date such litigation is filed.

4. Redistribution. You may reproduce and distribute copies of the Work or Derivative Works thereof in any medium, with or without modifications, and in Source or Object form, provided that You meet the following conditions:
 - (a) You must give any other recipients of the Work or Derivative Works a copy of this License; and
 - (b) You must cause any modified files to carry prominent notices stating that You changed the files; and
 - (c) You must retain, in the Source form of any Derivative Works that You distribute, all copyright, patent, trademark, and attribution notices from the Source form of the Work, excluding those notices that do not pertain to any part of the Derivative Works; and
 - (d) If the Work includes a "NOTICE" text file as part of its distribution, then any Derivative Works that You distribute must include a readable copy of the attribution notices contained within such NOTICE file, excluding those notices that do not pertain to any part of the Derivative Works, in at least one of the following places: within a NOTICE text file distributed as part of the Derivative Works; within the Source form or documentation, if provided along with the Derivative Works; or, within a display generated by the Derivative Works, if and wherever such third-party notices normally appear. The contents of the NOTICE file are for informational purposes only and do not modify the License. You may add Your own attribution notices within Derivative Works that You distribute, alongside or as an addendum to the NOTICE text from the Work, provided that such additional attribution notices cannot be construed as modifying the License.

You may add Your own copyright statement to Your modifications and may provide additional or different license terms and conditions for use, reproduction, or distribution of Your modifications, or for any such Derivative Works as a whole, provided Your use, reproduction, and distribution of the Work otherwise complies with the conditions stated in this License.

5. Submission of Contributions. Unless You explicitly state otherwise, any Contribution intentionally submitted for inclusion in the Work by You to the Licensor shall be under the terms and conditions of this License, without any additional terms or conditions. Notwithstanding the above, nothing herein shall supersede or modify the terms of any separate license agreement you may have executed with Licensor regarding such Contributions.
6. Trademarks. This License does not grant permission to use the trade names, trademarks, service marks, or product names of the Licensor, except as required for reasonable and customary use in describing the origin of the Work and reproducing the content of the NOTICE file.
7. Disclaimer of Warranty. Unless required by applicable law or agreed to in writing, Licensor provides the Work (and each

Contributor provides its Contributions) on an "AS IS" BASIS, WITHOUT WARRANTIES OR CONDITIONS OF ANY KIND, either express or implied, including, without limitation, any warranties or conditions of TITLE, NON-INFRINGEMENT, MERCHANTABILITY, or FITNESS FOR A PARTICULAR PURPOSE. You are solely responsible for determining the appropriateness of using or redistributing the Work and assume any risks associated with Your exercise of permissions under this License.

8. Limitation of Liability. In no event and under no legal theory, whether in tort (including negligence), contract, or otherwise, unless required by applicable law (such as deliberate and grossly negligent acts) or agreed to in writing, shall any Contributor be liable to You for damages, including any direct, indirect, special, incidental, or consequential damages of any character arising as a result of this License or out of the use or inability to use the Work (including but not limited to damages for loss of goodwill, work stoppage, computer failure or malfunction, or any and all other commercial damages or losses), even if such Contributor has been advised of the possibility of such damages.
9. Accepting Warranty or Additional Liability. While redistributing the Work or Derivative Works thereof, You may choose to offer, and charge a fee for, acceptance of support, warranty, indemnity, or other liability obligations and/or rights consistent with this License. However, in accepting such obligations, You may act only on Your own behalf and on Your sole responsibility, not on behalf of any other Contributor, and only if You agree to indemnify, defend, and hold each Contributor harmless for any liability incurred by, or claims asserted against, such Contributor by reason of your accepting any such warranty or additional liability.

END OF TERMS AND CONDITIONS

APPENDIX: How to apply the Apache License to your work.

To apply the Apache License to your work, attach the following boilerplate notice, with the fields enclosed by brackets "[]" replaced with your own identifying information. (Don't include the brackets!) The text should be enclosed in the appropriate comment syntax for the file format. We also recommend that a file or class name and description of purpose be included on the same "printed page" as the copyright notice for easier identification within third-party archives.

Copyright [yyyy] [name of copyright owner]

Licensed under the Apache License, Version 2.0 (the "License");
you may not use this file except in compliance with the License.
You may obtain a copy of the License at

<http://www.apache.org/licenses/LICENSE-2.0>

Unless required by applicable law or agreed to in writing, software distributed under the License is distributed on an "AS IS" BASIS, WITHOUT WARRANTIES OR CONDITIONS OF ANY KIND, either express or implied. See the License for the specific language governing permissions and limitations under the License.

System.Data.SQLite.EF6.Migrations

Microsoft Public License (MS-PL)

This license governs use of the accompanying software. If you use the software, you accept this license. If you do not accept the license, do not use the software.

1. Definitions

The terms "reproduce," "reproduction," "derivative works," and "distribution" have the same meaning here as under U.S. copyright law.

A "contribution" is the original software, or any additions or changes to the software.

A "contributor" is any person that distributes its contribution under this license.

"Licensed patents" are a contributor's patent claims that read directly on its contribution.

2. Grant of Rights

(A) Copyright Grant- Subject to the terms of this license, including the license conditions and limitations in section 3, each contributor grants you a non-exclusive, worldwide, royalty-free copyright license to reproduce its contribution, prepare derivative works of its contribution, and distribute its contribution or any derivative works that you create.

(B) Patent Grant- Subject to the terms of this license, including the license conditions and limitations in section 3, each contributor grants you a non-exclusive, worldwide, royalty-free license under its licensed patents to make, have made, use, sell, offer for sale, import, and/or otherwise dispose of its contribution in the software or derivative works of the contribution in the software.

3. Conditions and Limitations

(A) No Trademark License- This license does not grant you rights to use any contributors' name, logo, or trademarks.

(B) If you bring a patent claim against any contributor over patents that you claim are infringed by the software, your patent license from such contributor to the software ends automatically.

(C) If you distribute any portion of the software, you must retain all copyright, patent, trademark, and attribution notices that are present in the software.

(D) If you distribute any portion of the software in source code form, you may do so only under this license by including a complete copy of this license with your distribution. If you distribute any portion of the software in compiled or object code form, you may only do so under a license that complies with this license.

(E) The software is licensed "as-is." You bear the risk of using it. The contributors give no express warranties, guarantees or conditions. You may have additional consumer rights under your local laws which this license cannot change. To the extent permitted under your local laws, the contributors exclude the implied warranties of merchantability, fitness for a particular purpose and non-infringement.

Section Configuration Software

Description

1	Summary	4
2	System Diagram	4
3	Operating Environment	5
4	Compatible System Controllers	5
5	Glossary	5
6	Initial Settings	6
	PC and Browser Settings	6
	How to set up your PC IP Address	6
	Installing the Software	7
7	Startup and Initial Procedure	8
	Re-edit folders downloaded from the System Controller	9
	Edit the System Controller setting file directly	9
8	How to Use this Software	10
	Main Screens of this Software	10
	Changing Layer Names	10
	Saving Changes	11
	Uploading Saved Data to the System Controller	11
9	Layout Settings	12
	What is the Layout Display?	12
	Compatible Models for Layout Display	12
	Images for Layout	12
	How to Configure	13
	Open the Layout Setting screen	13
	Setting the Layer Group Name.....	13
	Setting a layout image for the layer.....	14
	Placement of Indoor Unit Icons	15
	Positioning of LD icons, FS unit icons and CO₂ Sensor icons	17
	Showing wiring between FS unit icons, LD unit icons or CO₂ Sensor icons and indoor units	19
	Saving Layout Settings	21

10	Detailed Explanation of this Software	22
	Main Screen	22
	Download settings Screen	22
	IP Address Search	23
	Upload settings Screen	24
11	Troubleshooting	25
12	OSS License	26

1 Summary

With this software, you can change the name of the layer [Floor, Tenant, Area, Monthly report tenant] displayed and indoor unit name on the system controller.
 You can also configure the layout displayed on the Layout screen and the layout of indoor units.

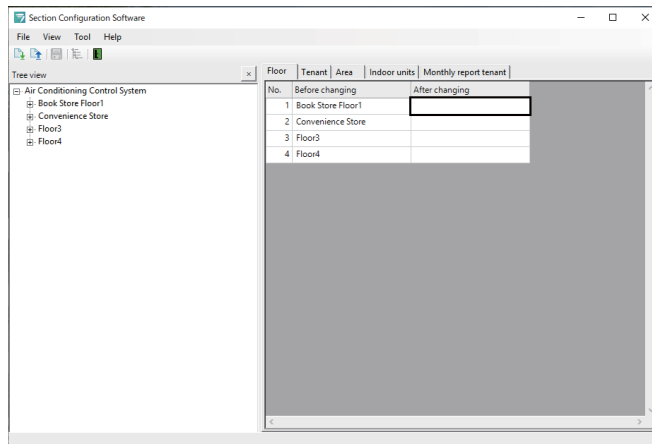

Section configuration software main screen (example)

* Each screen is an example of the display. The display screen may vary depending on the version of your software.

2 System Diagram

This diagram shows the connections between the PC and the system controller.

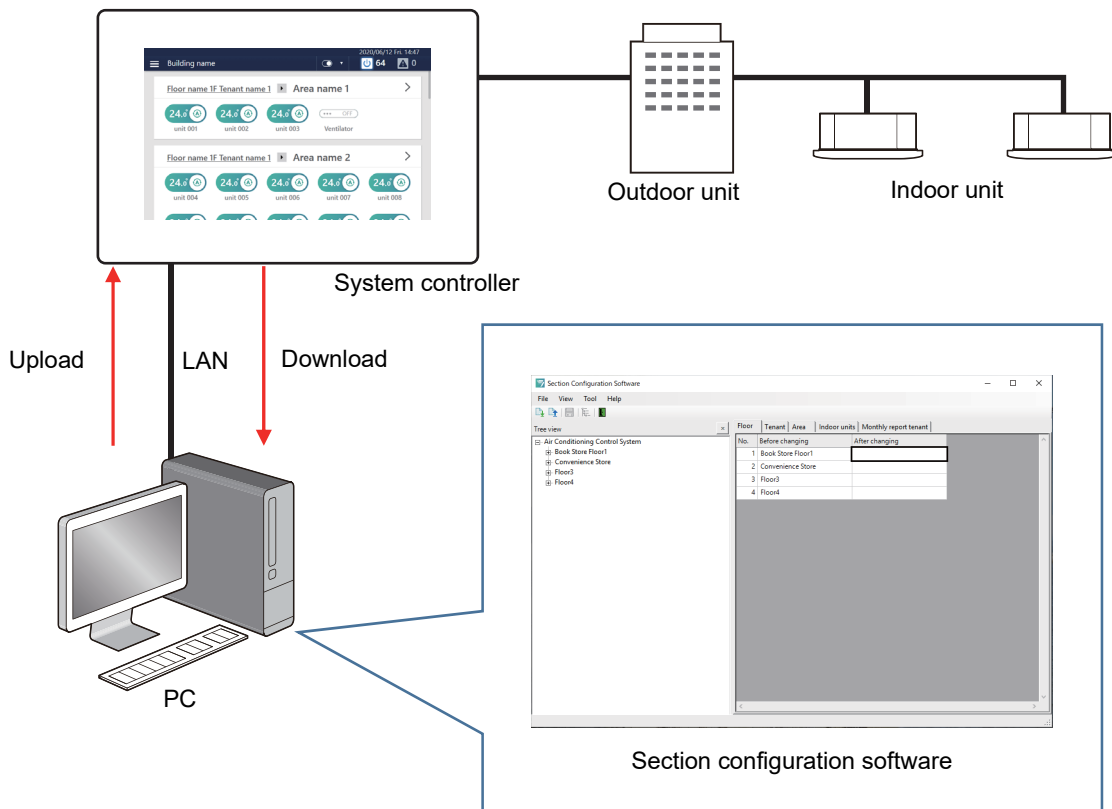

3 Operating Environment

Item	Required Environment
OS	Windows 10, Windows 11

4 Compatible System Controllers

Device name	Model
Touch screen controller	BMS-CT5120UL
Touch screen controller (CT128/256 series)	BMS-CT1280UL
	BMS-CT2560U-UL
	BMS-CT2560U-UL (Ver.10.3.0.0 or later)
Smart BMS manager	BMS-SM1280HTUL(*)
	BMS-SM1280TLUL

5 Glossary

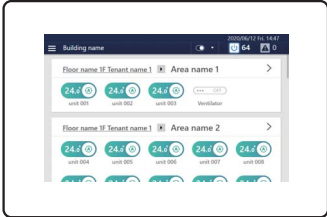
Term	Meaning
System controller	Controller that monitors and controls indoor and outdoor units 
Floor	Name of the floor such as "1st floor" or "2nd floor"
Tenant	Name of the tenant such as "ABC store" or "Class room 3"
Area	Name of area such as "East" or "West"
Indoor unit	Name of air conditioners and ON/OFF devices installed indoors
Monthly report tenant	Name of tenant displayed on monthly report *
Indoor unit icon	Icon indicating the indoor unit
Leak Detector (LD)	Refrigerant leak detector In the manual, it is partially described as LD.
FS Unit	Equipment that controls refrigerant.

* It is not possible to output monthly reports with this software. You can output monthly reports, etc. with the Energy report software 2. For details, refer to the instruction manual of the Energy report software 2.

6 Initial Settings

PC and Browser Settings

Please set up your PC as follows:

IP address/ subnet mask	Set these so that the PC is on the same network as the system controller. (Example: System controller 192.168.2.80/PC 192.168.2.90/Subnet mask 255.255.255.0)
C drive	Ensure that you have 500 MB or more free space and start up as a user with read/write authority.

How to set up your PC IP Address

1. Display the properties of the network you will use to connect to the system controller.
2. Check "Internet Protocol Version 4 (TCP/IPv4)" and click the [Properties] button.
3. Select [Use the following IP address:], set the IP address to 192.168.2.*** and the subnet mask to 255.255.255.0., then click the [OK] button. *

* Enter an address that is different from the system controller's address for "***".

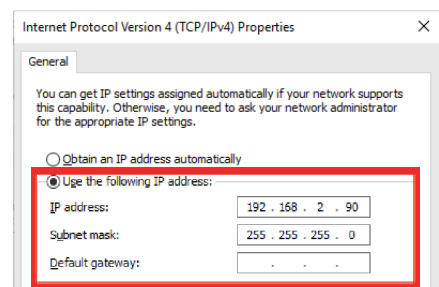

Note

If your PC is set to use a proxy server, exclude the IP address of the System Controller.

Installing the Software

1. Connect the system controller to the PC and open your web browser.
2. Access [http://[destination IP address ^{*}]/touchscreencontroller/[language code]/download.html].

The language codes are as follows:

Language	Language Code
English	EN-UL
French	FR-UL
Spanish	ES-UL

* IP address initial value: 192.168.2.80

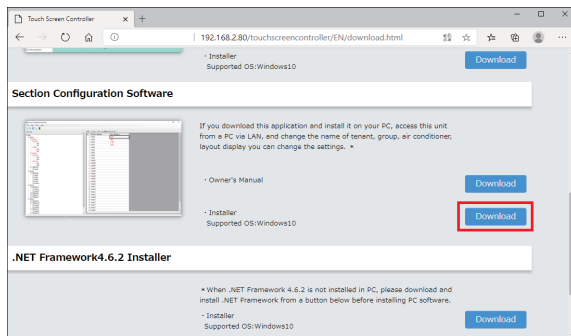

3. Click the area shown in the red frame.
4. Save the file in accordance with the message shown by the browser.
5. Unzip the <setup.exe> file that you saved and install it.
When installation is complete, a shortcut icon is created on the desktop.

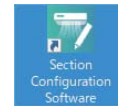

Troubleshooting

If the installation fails, refer to P.25.

7 Startup and Initial Procedure

Start up the software.

* When you first start up the software, the "Select Country" screen appears. Select the "Country" and click the [OK] button.

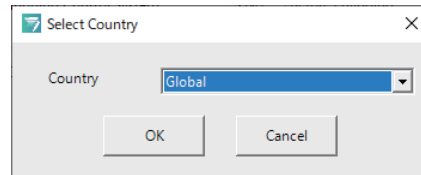

After starting up, the Main screen appears.

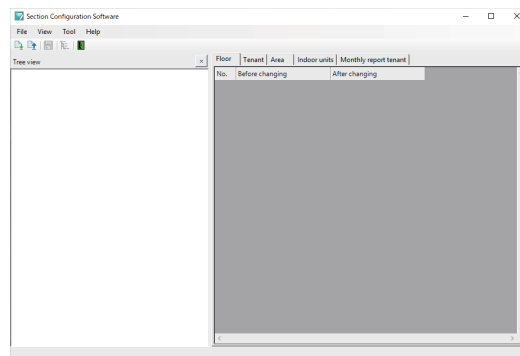

Select [File] → [Download] on the menu bar or click the  icon.

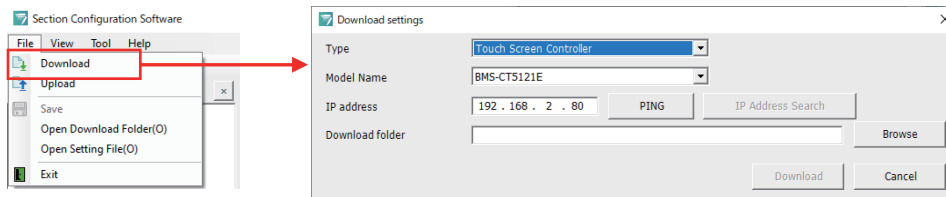

The "Download settings" screen appears. Enter the information for the connected system controller.

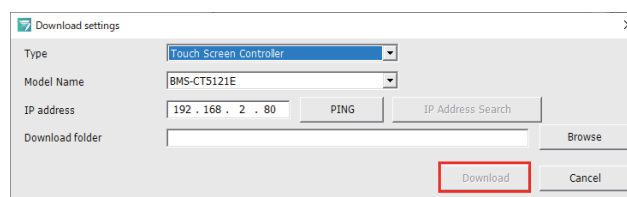

After entering all the information, click the [Download] button and download the data from the system controller.

When downloading is complete, the display returns to the Main screen.

Re-edit folders downloaded from the System Controller

Click [File] - [Open Download Folder] in the menu bar.

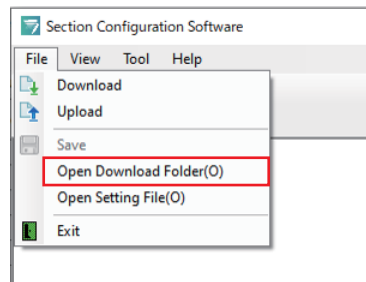

Edit the System Controller setting file directly

Click [File] - [Open Setting File] in the menu bar.

Only BMS-CT2560U-UL (Ver.10.3.0.0 or later) can be selected.

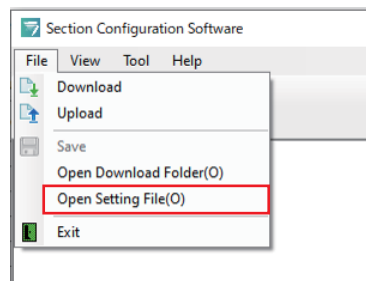

Note

- The setting file to be edited must be stored in the DEF folder.
Create a DEF folder and save the setting file in it.
- Do not store more than one setting file in the same DEF folder.

8 How to Use this Software

This section describes the basic operation method of this software.

Main Screens of this Software

"Tree view"
It shows the structure of the system based on the data from the connected system controller.

<Section screen>
You can change the name of each layer. The layers shown in the "Tree view" are displayed on each tab.

Changing Layer Names

Click the layer tab you want to change on the Section screen.

Enter the new name in the "After changing" column for the name you want to change. *

Floor				Tenant	Area	Indoor units	Monthly report tenant
No.	Before changing		After changing				
1	Floor1						
2	Convenience Store						
3	Floor3						

Floor				Tenant	Area	Indoor units	Monthly report tenant
No.	Before changing		After changing				
1	Floor1		Book Store Floor1				
2	Convenience Store						
3	Floor3						

* When you enter text in the "After changing" column, it will be shown in red.

Tree view				Floor				Tenant	Area	Indoor units	Monthly report tenant
		No.	Before changing		After changing						
Air Conditioning Control System		1	Floor1		Book Store Floor1						
<ul style="list-style-type: none"> Book Store Floor1 Convenience Store Floor3 		2	Convenience Store								

Saving Changes

If you want to save the changes, select [File] → [Save] or click the  icon.

Uploading Saved Data to the System Controller

Select [File] → [Upload] on the menu bar or click the  icon.

The "Upload settings" screen appears.

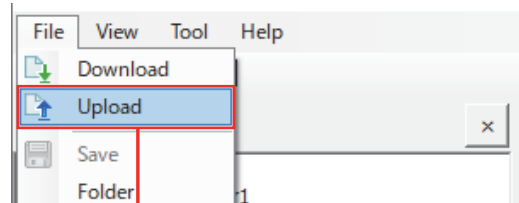

Click the [Upload] button to upload the data that you have changed to the connected system controller.

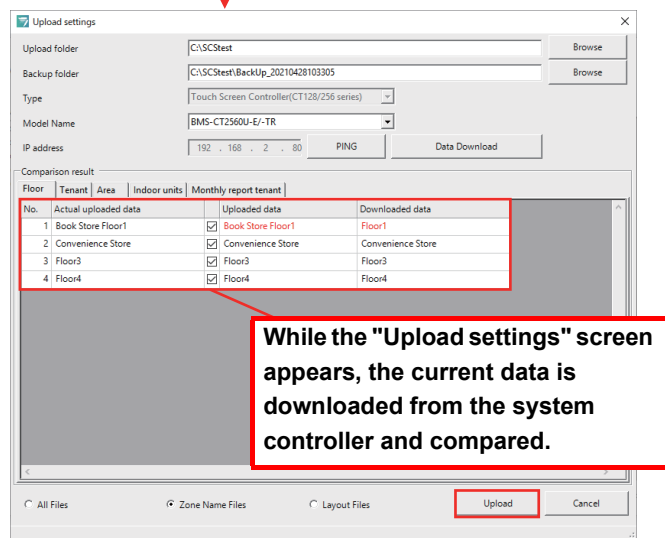

Troubleshooting

- Connection check failed
- Upload failed

If one of these errors occurs, see P.25.

9 Layout Settings

What is the Layout Display?

By laying out the indoor units on image data such as a floor plan of the building, you can monitor and control from a screen that shows the floor plan.

The layout will only be displayed for compatible models.

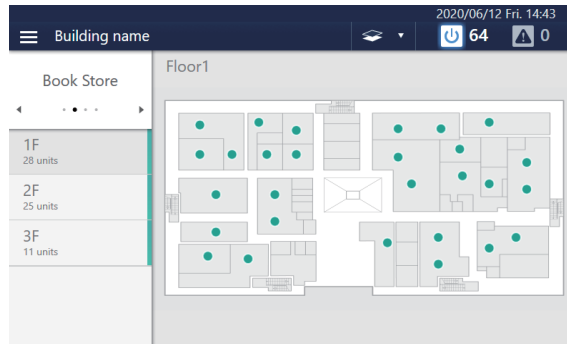

Example of a Touch screen controller (CT128/256 series)

Note

Refer to the instruction manual of the system controller for more information about monitoring and control on the Layout screen. The following explanation of the Layout screen is based on the screen for a Touch screen controller (CT128/256 series).

Compatible Models for Layout Display

The following model is compatible:

Model	Model Name
Touch screen controller (CT128/256 series)	BMS-CT2560U-UL
	BMS-CT2560U-UL (Ver.10.3.0.0 or later)

Images for Layout

The following images can be used for Layout:

Model	Model Name	Size (W x H) [pixels]	Format	Layout Number of files	File size (per file)
Touch screen controller (CT128/256 series)	BMS-CT2560U-UL	800 × 416	PNG	16	10 MB
	BMS-CT2560U-UL (Ver.10.3.0.0 or later)				

How to Configure

Open the Layout Setting screen

To change the layout settings, select [Tool] → [Layout Setting] on the menu bar.

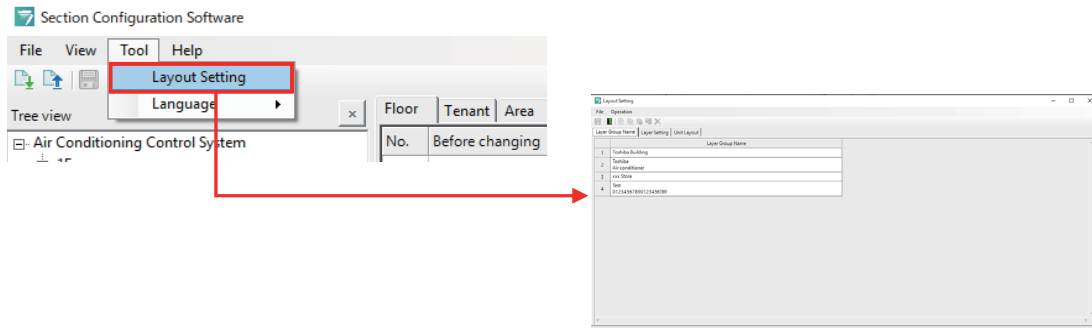

The items entered on the Layout Setting screen are displayed as shown on the system controller screen.

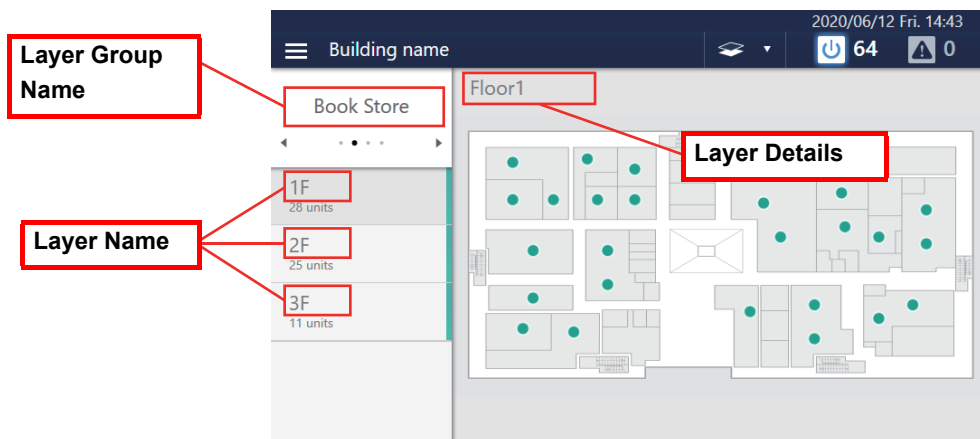

Example of a Touch screen controller (CT128/256 series)

Setting the Layer Group Name

Click the [Layer Group Name] tab.

Select [Operation] → [New] on the menu bar or click the  icon and enter the name. *

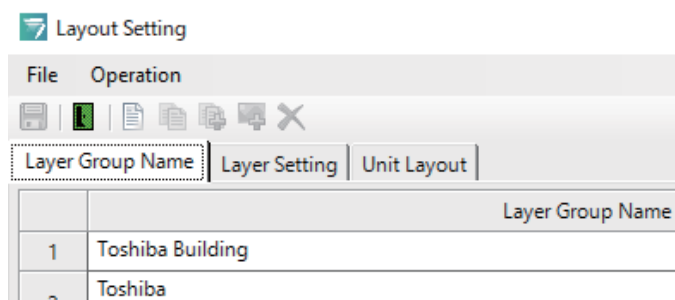

* If you want to include a line break, press [Shift]+[Enter].

Setting a layout image for the layer

Click the [Layer Setting] tab.

Select [File] → [Add layout image] on the menu bar or the  icon to add the layout image you want to use to the software. *

If you want to set an image for the layer, click the [▼] button of the "Layout Files" item to select it.

Toshiba Building			
	Layer Name	Layer Details	Layout Files
1	Shopping mall 1F	The first floor	200114_2718_01_1.dat
2	Shopping mall 2F	Second floor	#101_East.dat
3	Book Store	Third floor	#101_North.dat
			#101_South.dat
			#101_West.dat
			200114_2718_01_1.dat
			200114_2718_01_2.dat
			200114_2718_01_3.dat
			200114_2718_01_4.dat

**You can enter an explanation of the layer.
It is not possible to use line breaks in the explanation.**

* Be sure to add images using [Add layout image] on the menu bar or the  icon.

Note

When editing BMS-CT2560U-UL (Ver.10.3.0.0 or later) data, layout images with the same name cannot be set to more than one hierarchy.

Placement of Indoor Unit Icons

Follow the steps below to place indoor unit icons  on the layout image.

Indoor unit icon layout screen functions

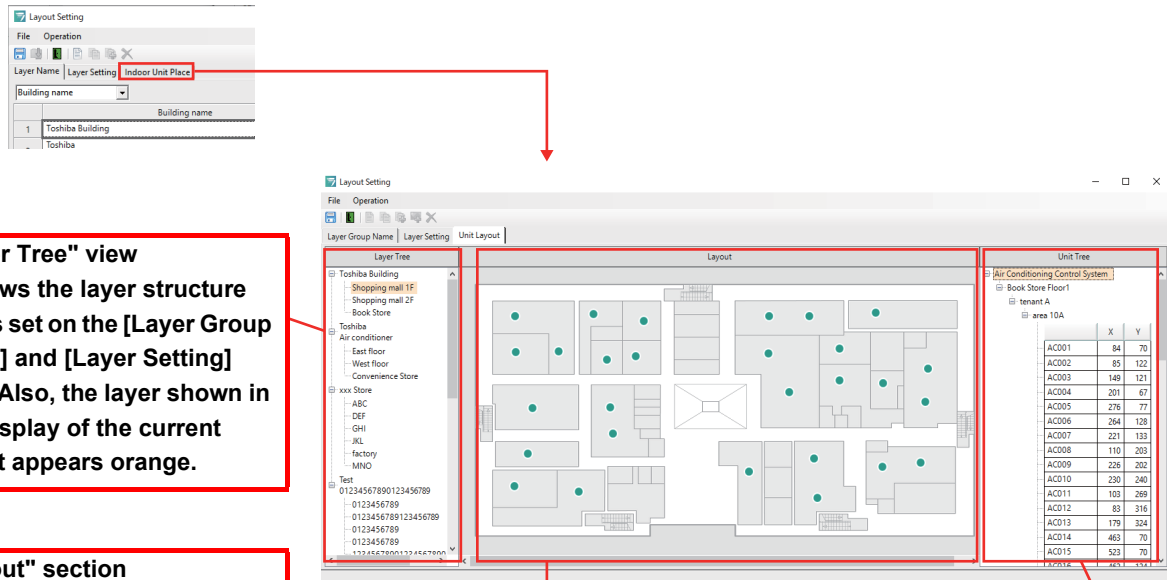

Select a layer from the "Layer Tree" view and place the indoor unit icons.

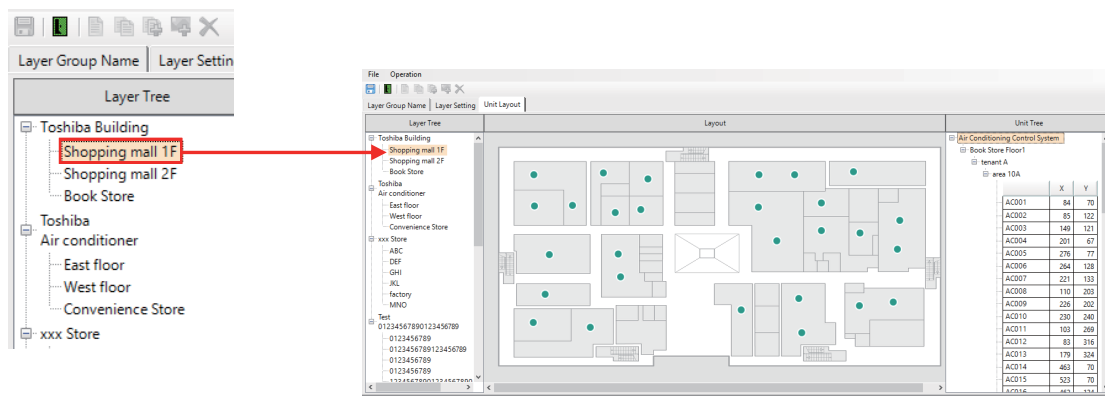

Enter the "X coordinate (horizontal)" and "Y coordinate (vertical)" for the indoor unit you want to place from the "Unit Tree" view. Alternatively, you can drag and drop the indoor unit onto the layer layout.

You can also change the position of indoor unit icons placed on the layout by dragging.

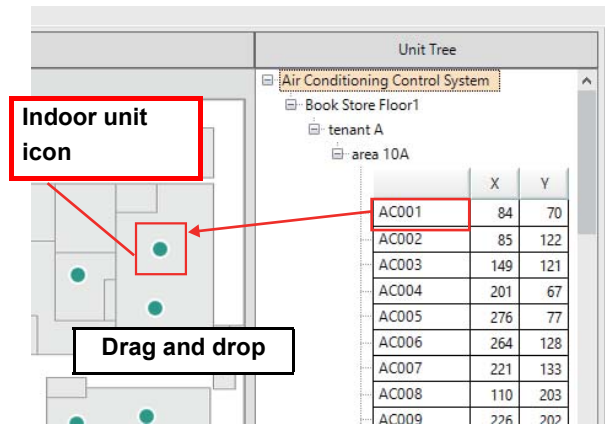

The figure on the right shows an example of the coordinates when placing an indoor unit icon.

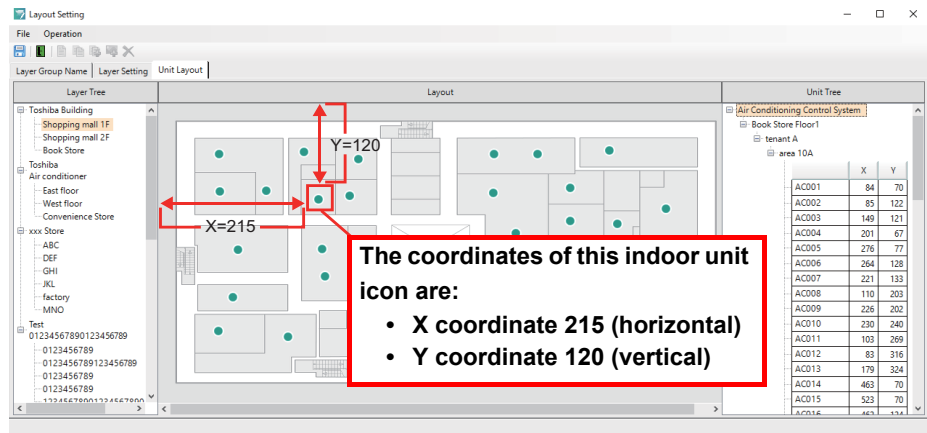

Note

When setting the layout with the Touch screen controller (CT128/256 series), do not place the indoor unit icon in the following position.

X Coordinate: 0 to 86 pixels

Y Coordinate: 0 to 86 pixels

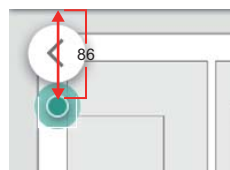
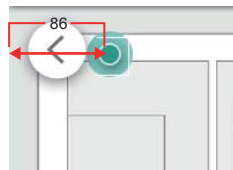

If you place the indoor unit icon at the above position, it will overlap the < button when zooming on the layout screen, so you may not be able to tap the placed indoor unit icon.

Positioning of LD icons, FS unit icons and CO₂ Sensor icons

Only BMS-CT2560U-UL (Ver.10.3.0.0 or later) can be placed.

Use the following procedure to position LD icons, FS unit icons and CO₂ Sensor icons connected to indoor units.

(1) Right-click an indoor unit name in the Unit Tree view to open a menu.

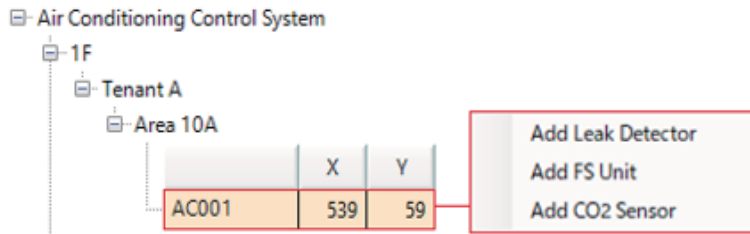

Note

The menu does not open, even if you right-click, if no indoor unit icons have been positioned.

(2) From the menu, select a device you want to add.

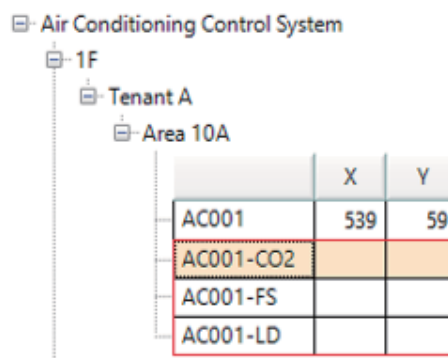

Name	Outline
FS Unit ■	You can check the positions of the connected indoor units and the FS units connected to coolant pipes at which an abnormality occurred.
Leak Detector (LD) ◆	You can check the positions of the connected indoor units and the LDs that have detected a coolant leak abnormality.
CO ₂ Sensor ▲	You can check the positions of the connected indoor units and CO ₂ Sensor that have detected excessive CO ₂ concentration.

- (3) Input the coordinates in the "X Coordinate (Horizontal)" and "Y Coordinate (Vertical)" of the LD, FS unit or CO₂ Sensor that was added, or drag and drop from the Unit Tree to the layout area.

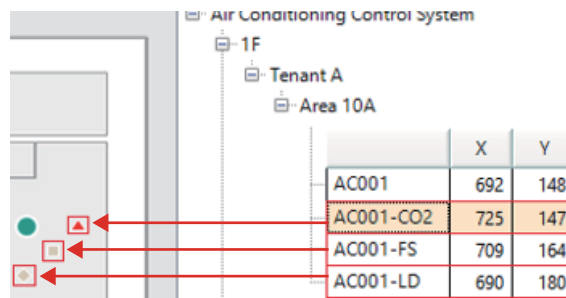

Note

For BMS-CT1280TU (Ver.10.3.0.0 or later)

Check if there is an icon that overlaps at the same coordinates when the coordinate overlap check button is clicked.

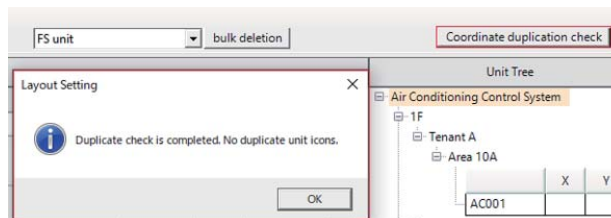

If duplicate icons are positioned at the same coordinates in the layout screen, the relevant items are shown in red and a text appears at the bottom left of the screen.

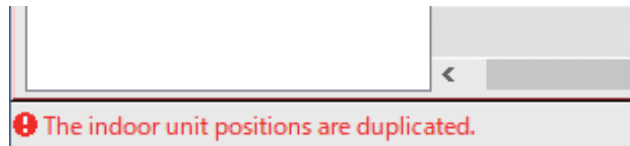

Showing wiring between FS unit icons, LD unit icons or CO₂ Sensor icons and indoor units

You can show the wiring connecting the indoor unit icons and the added FS unit icons, LD unit icons or CO₂ Sensor icons. If you want to show the wiring, follow the procedure below.

Right-click on the icon of FS unit, LD unit or CO₂ Sensor, and then click [Draw Wiring to Indoor unit].

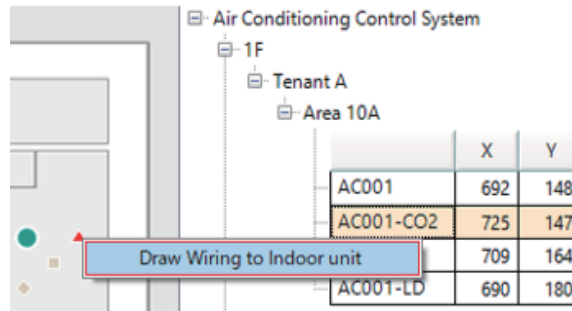

You can select multiple indoor units on the layout screen when you draw wiring to an indoor unit from an FS unit.

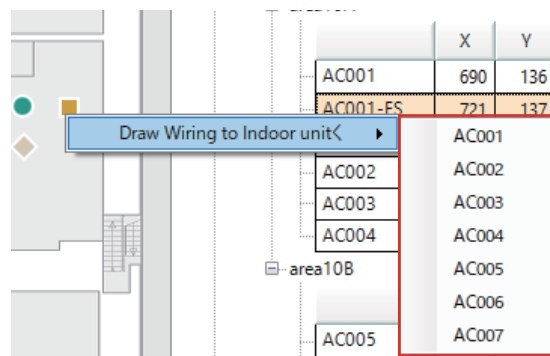

If you draw wiring for an FS unit to an indoor unit icon with a different indoor unit name, then it is shown as a dotted line.

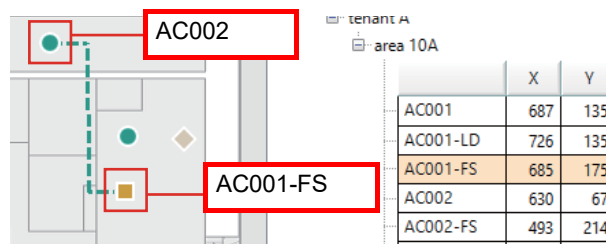

If you change the position of an icon after drawing wiring to that icon, the wiring does not move.
To redraw the wiring, you need to first delete the wiring and then redraw the wiring.

Deleting icons and wiring

If you want to delete the wiring to various icons positioned in the layout screen, follow the various procedures below.

- Indoor unit icon

Select the indoor unit icon you want to delete, and then click the  icon or [Operation] - [Delete] on the menu bar.

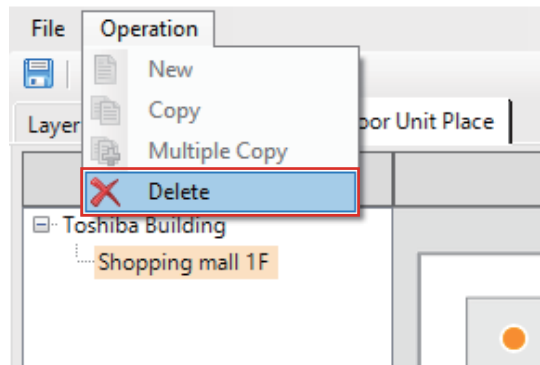

- FS unit icons, LD icons and CO₂ Sensor icons

In the Unit Tree view, right click the FS unit, LD or CO₂ Sensor you want to delete, and then click [Delete].

Area 10A

	X	Y
AC001	692	148
AC001-CO2	725	147
AC001-FS	709	164
AC001-LD	692	180

A 'Delete' button is shown below the table, with a red box around it.

If you want to delete them all at once, select them and click [Bulk deletion].

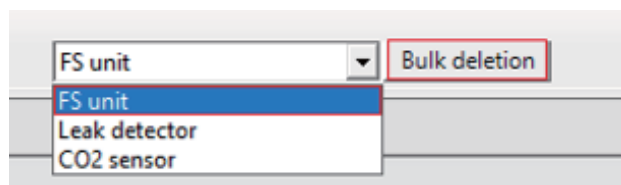

- Wiring

Right-click on an FS unit icon, an LD icon or a CO₂ Sensor to which wiring was drawn, and then click [Delete Wiring].



After that, a pop-up message appears. Clicking [Yes] deletes the wiring.

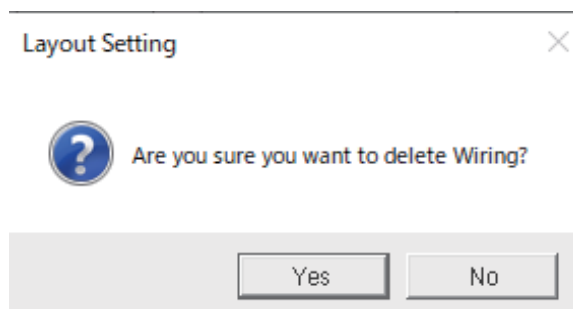

If you have drawn multiple wires to an FS unit icon, you can also select from the menu and delete indoor unit icons to which the wiring is connected.

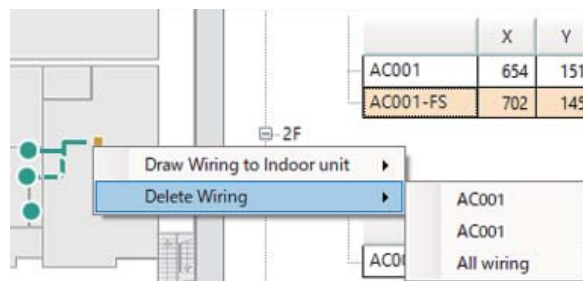

Saving Layout Settings

Select [File] → [Save] on the menu bar or the  icon to save the Layout Setting.

You must upload saved data to the system controller. Refer to P.11 for the upload procedure.

10 Detailed Explanation of this Software

Main Screen

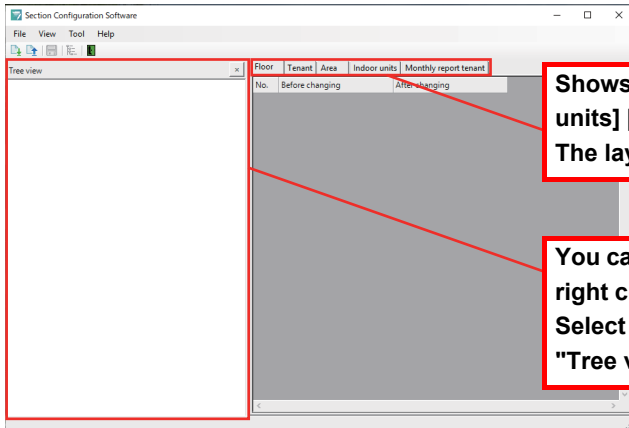

Shows five types of tabs: [Floor] [Tenant] [Area] [Indoor units] [Monthly report tenant].
The layers shown in the Tree view are listed on each tab.

You can hide the Tree view using the [X] button in the top right corner.
Select [View] → [Tree view] on the menu bar to display the "Tree view".

Download settings Screen

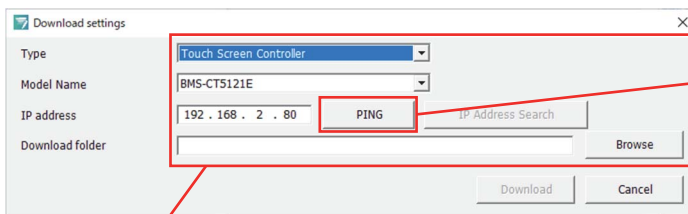

You can check whether the software is connected to the system controller. *

"Type": Select the system controller type.
"Model Name": Select the system controller model.
"IP address": Enter the system controller IP address.
"Download folder": Select the folder in which to save the data downloaded from the system controller.

* Connection check result

The images below are examples of the dialogue boxes that appear when checking connection with the system controller.

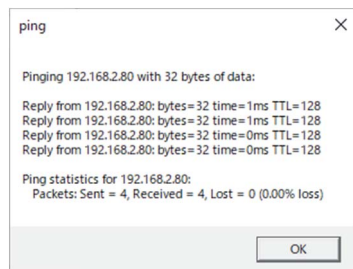

Normal

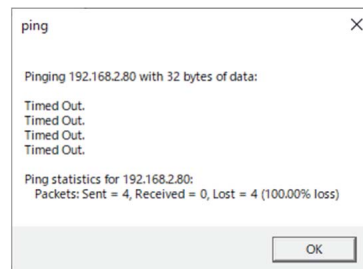

Error (example)

Troubleshooting

If the connection check fails, refer to P.25.

IP Address Search

You can search for and display the IP addresses of system controllers for which there is no way to check IP addresses.

Note

This function is applicable for only some system controllers.

Click the [IP Address Search] button, and after a while, the searched IP addresses appear.

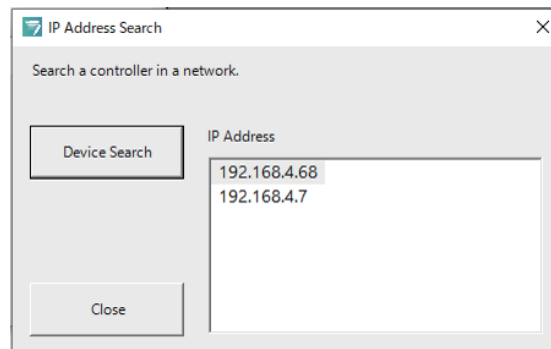

Upload settings Screen

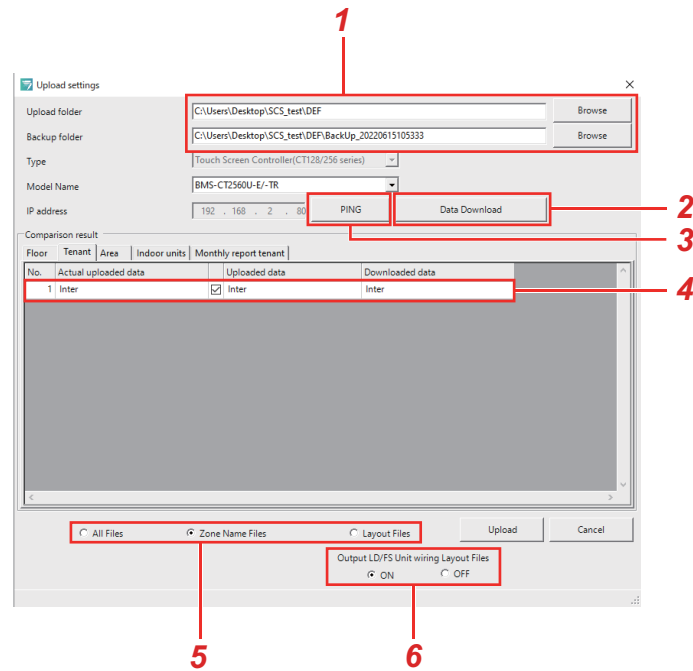

No.	Outline
1	"Upload folder": Select the folder from which to upload the data to the system controller. "Backup folder": Select a folder in which to create a backup folder.
2	Download the data from the system controller.
3	You can check whether the software is connected to the system controller. Refer to P.22 for more information about the result of checking the connection with the system controller.
4	Remove the check marks to use the data downloaded from the system controller as is.
5	Use the buttons shown in the red frame to change what to upload to the system controller. <ul style="list-style-type: none"> • Select the [All Files] to upload both the name settings and the layout settings. • Select the [Zone Name Files] to upload only the name settings. • Select the [Layout Files] to upload only the layout settings.
6	ON: Shows the wiring information created by using "Showing wiring between FS unit icons, LD unit icons or CO ₂ Sensor icons and indoor units" in the system controller. OFF: The wiring information created by using "Showing wiring between FS unit icons, LD unit icons or CO ₂ Sensor icons and indoor units" is not shown in the system controller.

11 Troubleshooting

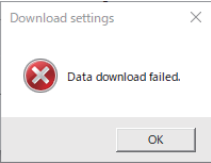
Phenomenon	No.	Question	Items to check or notes
I cannot install the software.	1	Are you using the specified OS on the PC?	Windows 10 and Windows 11 are supported.
	2	Does the logged-in Windows user account have administrator privileges?	This software cannot be installed with an account that does not have administrator privileges. Please install with an account that has administrator privileges.
	3	Does your computer have enough free space?	This software cannot be installed if there is not enough free space. Increase the free space to 500 MB or more before attempting to install the software.
Data download or upload failed. Connection check failed.  Example of error screen	4	Did you check the connection with the [PING] button?	Check the connection referring to P.22. If it fails, check 5, 6, and 7. If you can connect, check 8 and 9.
	5	Is the LAN cable connected?	Are the system controller and LAN cable connected?
	6	Did you change the IP address of the system controller?	If you have changed the IP address of the system controller, you must also change the IP address on the "Download settings" and "Upload settings" screens.
	7	Have you set the IP address of your PC?	Check the network settings of your PC.
	8	Are the details of the connected model correct?	Check the type and model specified on the "Download settings" and "Upload settings" screens.
	9	Is the port open?	Check if the port described in P.6 is open.
	10	After trying 4 to 9, are you still unable to download or upload?	If the problem is not resolved even after trying the above items, please contact your PC or network administrator.

12 OSS License

This software contains licensed software or software whose copyright is owned by a third party according to the following.

JamesNK_Newtonsoft.Json

The MIT License (MIT)

Copyright (c) 2007 James Newton-King

Permission is hereby granted, free of charge, to any person obtaining a copy of this software and associated documentation files (the "Software"), to deal in the Software without restriction, including without limitation the rights to use, copy, modify, merge, publish, distribute, sublicense, and/or sell copies of the Software, and to permit persons to whom the Software is furnished to do so, subject to the following conditions:

The above copyright notice and this permission notice shall be included in all copies or substantial portions of the Software.

THE SOFTWARE IS PROVIDED "AS IS", WITHOUT WARRANTY OF ANY KIND, EXPRESS OR IMPLIED, INCLUDING BUT NOT LIMITED TO THE WARRANTIES OF MERCHANTABILITY, FITNESS FOR A PARTICULAR PURPOSE AND NONINFRINGEMENT. IN NO EVENT SHALL THE AUTHORS OR COPYRIGHT HOLDERS BE LIABLE FOR ANY CLAIM, DAMAGES OR OTHER LIABILITY, WHETHER IN AN ACTION OF CONTRACT, TORT OR OTHERWISE, ARISING FROM, OUT OF OR IN CONNECTION WITH THE SOFTWARE OR THE USE OR OTHER DEALINGS IN THE SOFTWARE.

Energy Report Software 2

Description

1	Summary	4
2	System Diagram.....	4
3	About the air conditioning charge proportional distribution system.....	5
4	Operating Environment.....	7
5	Compatible System Controller.....	7
6	Glossary	7
7	Initial Settings	8
	PC and Browser Settings	8
	How to set up your PC IP address.....	8
	Installing the Software.....	9
8	Main Screens of This Software.....	10
9	Startup and Initial Procedure	11
	Updating Data.....	13
10	Summary of Screens for Each Mode.....	14
	Data analyzer Screen.....	15
	Report Screen.....	16
11	Data Analyzer.....	17
	Detailed Description of the Data Analyzer Screen	18
	Select the period to display in the graph	18
	Changing the graph display.....	19
	Description of Screens	20
	Trend graph	20
	Ranking	22
	Air-conditioning load	23
	Data Analyzer	24
	Print a graph	24
12	Reports.....	25
	Basic Operation Method	25
	Report window.....	27

	Billing Schedule	28
	How to Set the Billing Schedule	29
	Creating a Billing Schedule	30
	Saving Billing Schedule settings	31
	Copy Billing Schedule	31
13	History	32
	Check Code History	32
	Operation History	32
	History Screen Menu Bar	32
14	Various Settings	33
	Software Setting	33
	System Setting Screen	33
	System Registration Screen	34
	Checking the Connection on the System Registration Screen	34
	User Setting	35
	User Register Screen	35
	Table of User Levels	35
15	Troubleshooting	36
	When Adjusting Detailed Settings or Making Changes	36
	When a Problem Occurs	41
16	OSS License	43

1 Summary

This software allows you to download data from the system controller about indoor units such as operating time and power consumption, and use the following functions.

- Data analyzer screen: You can create graphs from the downloaded data, compare past data of the same unit, and visually check comparisons of operating data for other indoor units or groups of floors or tenants.
- Report screen: You can use the downloaded data to create monthly or daily reports, etc.



Data analyzer screen (example)

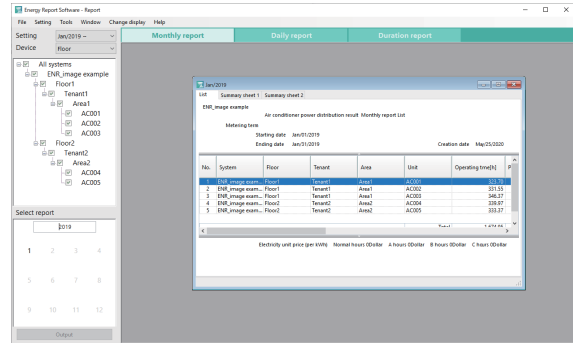

Report screen (example)

- * Each screen is an example of the display. The display screen may vary depending on the version of your software.
- * Although temperature is indicated in [°C] in the figures used in this manual, the initial temperature is displayed in [°F] on this software.

2 System Diagram

This diagram shows the connections between the PC and the system controller.

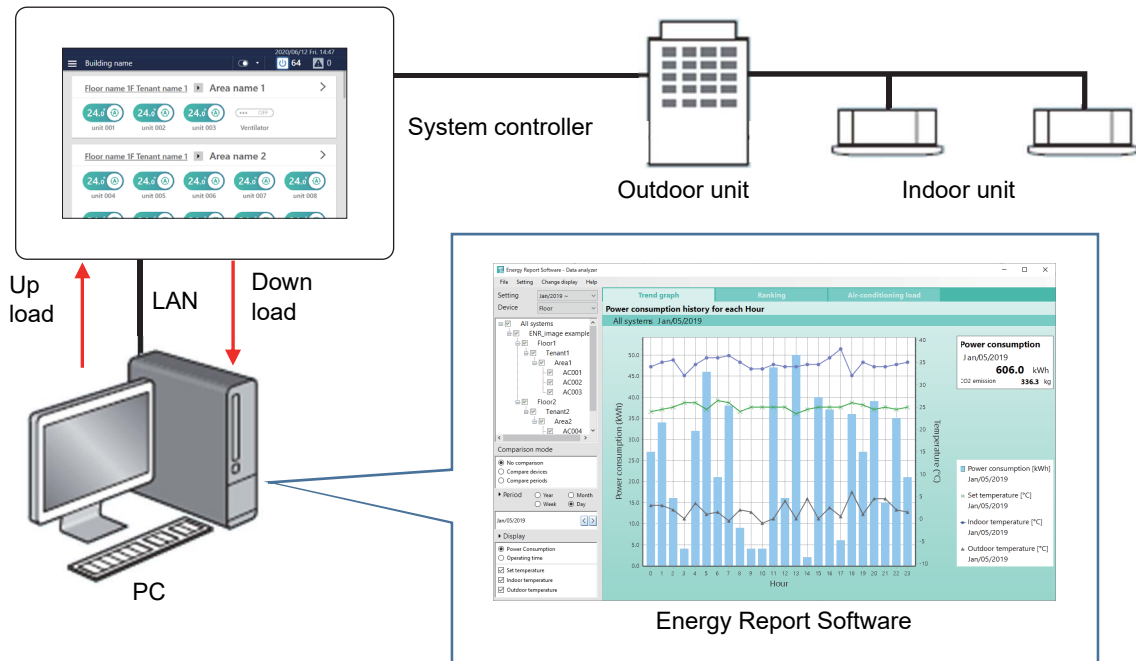

CAUTION

- When the system configuration or air conditioners are updated, the calculation results may change. This is because the operation data that is collected for the air conditioners or the data collection method will change.
- This system correctly calculates and displays the amount of energy and the apportionment result only when the air conditioner, system controller, and this software are operating normally.
- When using this system, make sure that no error has occurred in the air conditioner, etc.

3 About the air conditioning charge proportional distribution system

This function calculates the charge for electric power used for each room (each tenant) based on the amount of electric power acquired from the power meter.

The electric power used for air conditioners is composed of the “power consumed by the outdoor units” and the “power consumed by the indoor units” whenever they are operating, plus the “basic power consumed”, which is the power they are constantly consuming.

The air conditioning charge proportional distribution system calculates the charges for the “power consumed by the outdoor units”, the “power consumed by the indoor units”, and the “basic power consumed”, according to the usage of each indoor unit in each of the cooling systems.

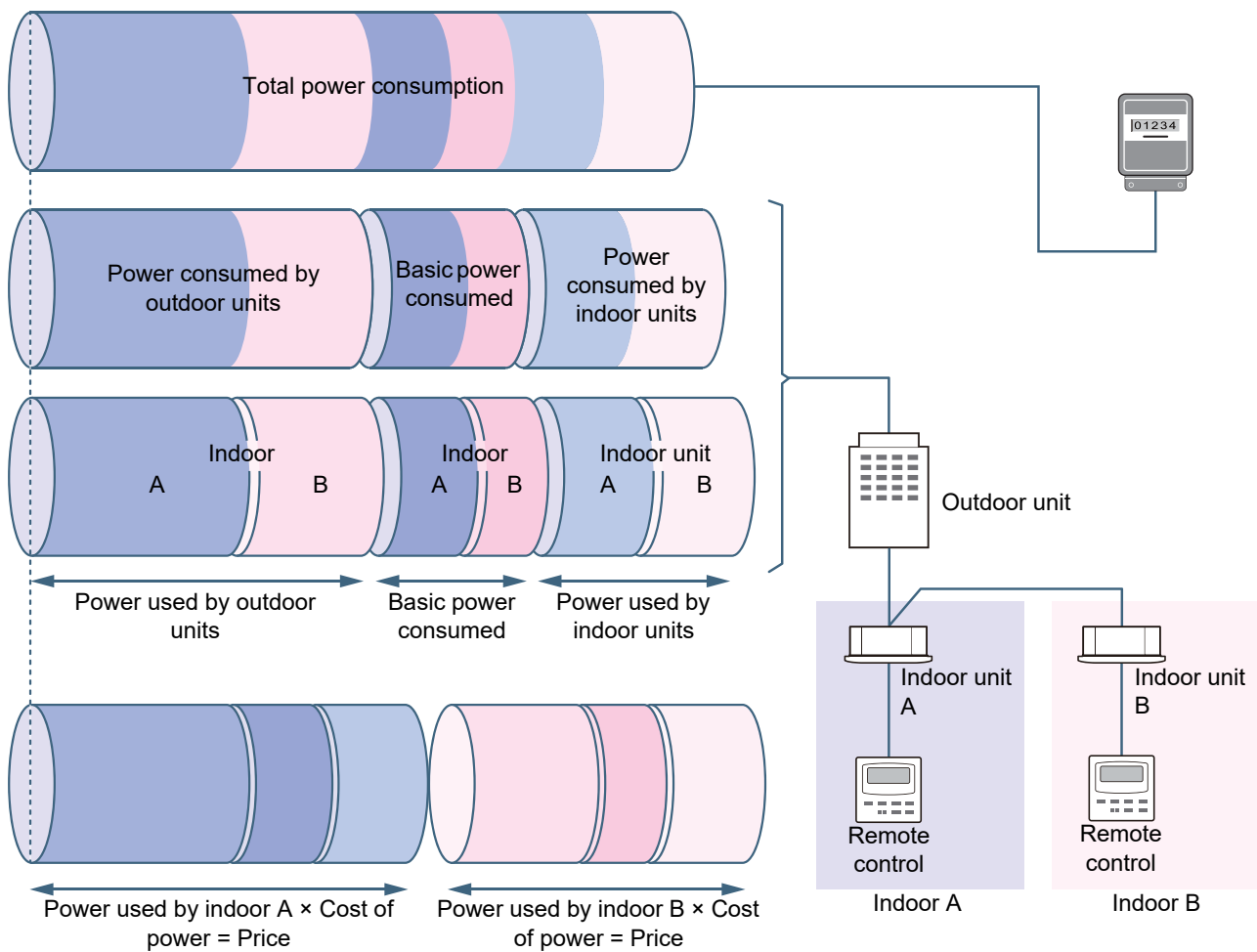

 CAUTION

- Using the accumulated power meter with pulse output, the software calculates the distribution of power accumulated by pulse conversion according to the load proportion estimated for each air-conditioner. The result is not calculated based on the Measurement Act and cannot be used officially.
 - Even if the operation hour is the same, the amount of power consumed varies depending on operating conditions such as the location of the air-conditioner, the set temperature, and the outdoor temperature.
 - The air-conditioner stays on for protection, even while stopped, and power is consumed. Therefore the software also calculates power consumed while the air-conditioner is not in use.
 - The software calculates the distribution of power according to the load proportion estimated for each air-conditioner. Therefore the result may differ from the actual amount of power consumed.
 - If a single power meter is installed in multiple air-conditioners, the total power is distributed. The result may differ when a power meter is installed in each air-conditioner.
 - The software calculates the pulse output using the accumulated power meter with pulse output. The result may differ from the actual amount of power consumed depending on the precision of the power meter. In particular, when the amount of electricity consumed in operation is low (when stopped, etc.), the result may differ from the actual amount of power consumed.
 - Please note that we bear no responsibility for any damage or problems that occur due to the software's distribution calculation, data loss, etc.
 - The calculation result contains rounding errors.
 - The software only supports the distribution calculation of power consumed by the air-conditioner. Please note the above when you use it.
-

4 Operating Environment

Item	Required Environment
OS	Windows 10, Windows 11
Microsoft Office *	Office 2013, 2016, 2019

* Only necessary if you wish to output reports in Excel format.

- Windows®, Excel® are trademarks or registered trademarks of Microsoft Corporation in the United States and other countries.
- All company names and product names that appear in this manual are trademarks or registered trademarks of their respective holders. In this manual such names are not indicated by ® or © marks.

5 Compatible System Controller

Software	Device name	Model
Energy Report Software 2	Touch Screen Controller (CT128/256 series)	BMS-CT2560U-UL (10.3.0.0 and later)
Energy Report Software		BMS-CT2560U-UL (Earlier than 10.3.0.0)

6 Glossary

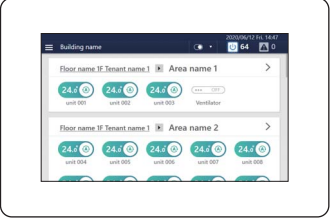
Term	Meaning
System controller	Controller that monitors and controls indoor and outdoor units 
Floor	Name of the floor such as "1st floor" or "2nd floor"
Tenant	Name of the tenant displayed on the system controller main unit such as "ABC store" or "Class room 3"
Area	Name of area such as "East" or "West"
Monthly report tenant	Name of tenant displayed on monthly report, daily report, or duration report
Indoor unit	Air conditioners and ON/OFF devices installed indoors
Outdoor unit	Outdoor unit connected to an indoor unit
Power distribution	To distribute the electric power measured by the power meter based on the operating information of the devices connected to the system controller
Refrigerant system	A group of indoor units installed on the same refrigeration cycle

7 Initial Settings

PC and Browser Settings

Please set up your PC as follows:

IP address / subnet mask	Set these so that the PC is on the same network as the system controller. (Example: System controller 192.168.2.80 / PC 192.168.2.90 / Subnet mask 255.255.255.0)
C drive	Ensure that you have 500 MB or more free space and start up as a user with read / write authority.

How to set up your PC IP address

1. Display the properties of the network you will use to connect to the system controller.
2. Check "Internet Protocol Version 4 (TCP/IPv4)" and click the [Properties] button.
3. Select [Use the following IP address:], set the IP address to 192.168.2.*** and the subnet mask to 255.255.255.0., then click the [OK] button. *

* Enter an address that is different from the system controller's address for "****".

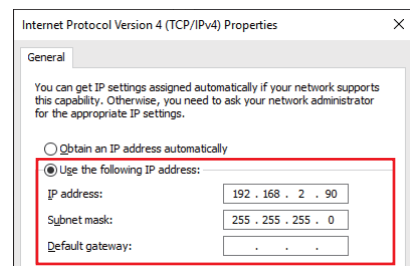

Notice

If your PC is set to use a proxy server, exclude the IP address of the System Controller.

Installing the Software

1. Connect the system controller to the PC and open your web browser.
2. Access [http://[destination IP address ^]/touchscreencontroller/[language code]/download.html].

The language codes are as follows:

Language	Language Code
English	EN-UL
French	FR-UL
Spanish	ES-UL

* IP address initial value: 192.168.2.80

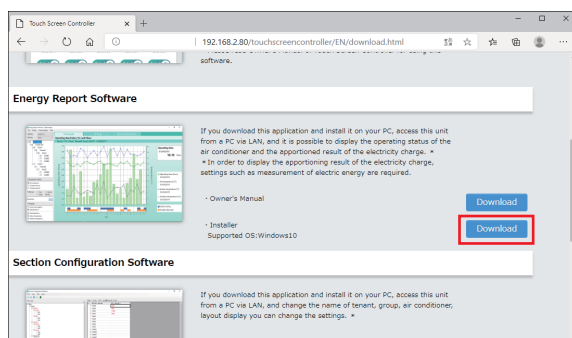

3. Click the area shown in the red frame.
4. Save the file in accordance with the message shown by the browser.
5. Unzip the <setup.exe> file that you saved and install it.
When installation is complete, a shortcut icon is created on the desktop.



8 Main Screens of This Software

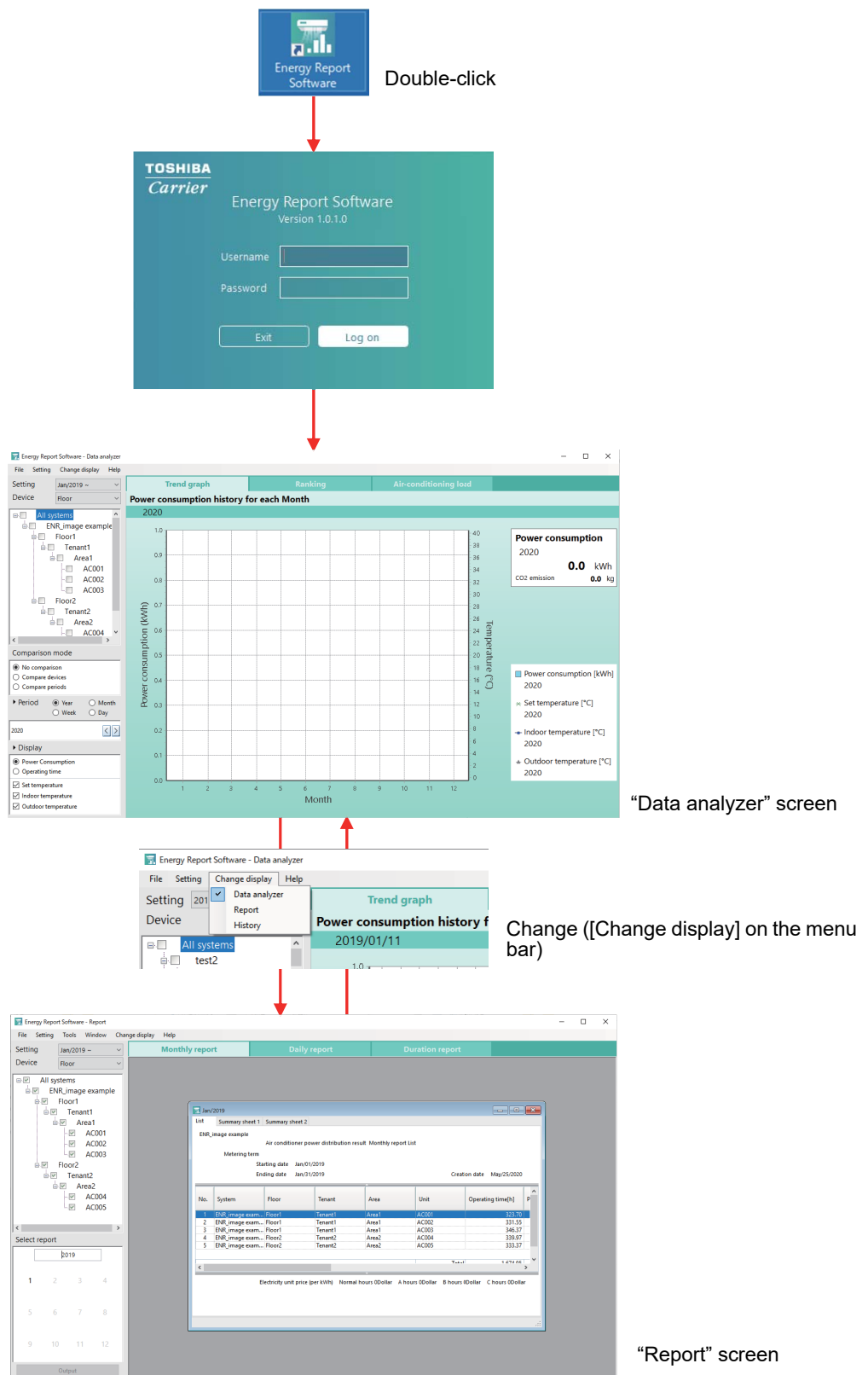

Notice

Click the minimize button to put the software in the task tray. Double-click the icon in the task tray to return the window to its previous size.

9 Startup and Initial Procedure

Start up the software.

When this software is started, a screen appears showing instructions and precautions for using it.

Select "Agree".

* When you first start up the software, the "Select Country" screen appears. Select the "Country" and click the [OK] button.

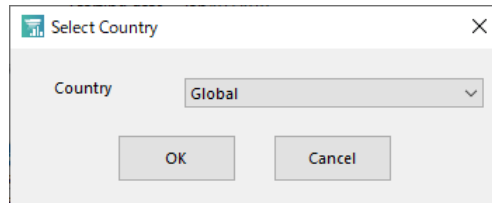

After starting up, the logon screen appears. Enter your "Username" and "Password", then click [Log on].



* When you start up the software for the first time you can log on with "Username" TCC and "Password" TCC.

After logging on, please register your username and password in the user settings. For details of the user settings, refer to P.35.

Troubleshooting

If you are unable to logon, refer to P.41.

When you first start up the software, after logging on, the display shifts to the “Data analyzer” screen. Click [System setting] on the [Setting] menu of the home screen.

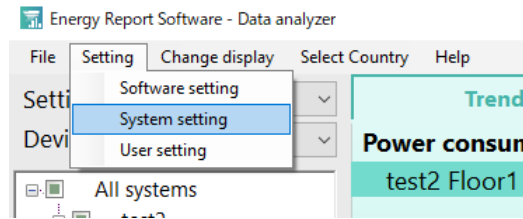

The “System registration” screen appears. Set each item and register the system.

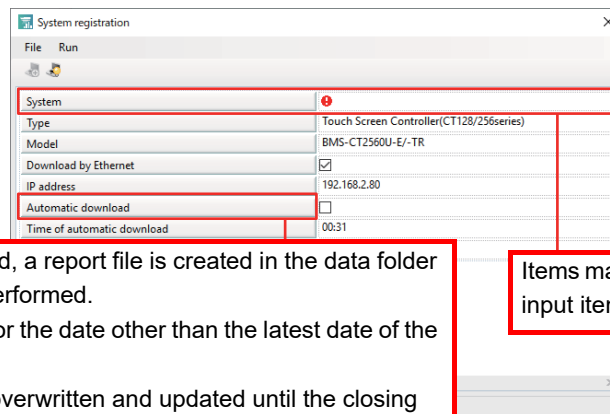

When this parameter is checked, a report file is created in the data folder when automatic download is performed. The daily report file is created for the date other than the latest date of the downloaded data. The monthly report file will be overwritten and updated until the closing date.

Items marked ! are required input items.

After you have saved the information on the “System registration” screen and closed the screen, downloading starts.

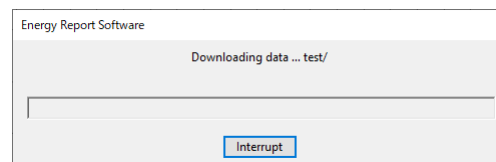

When downloading is complete, the display returns to the “Data analyzer” screen.

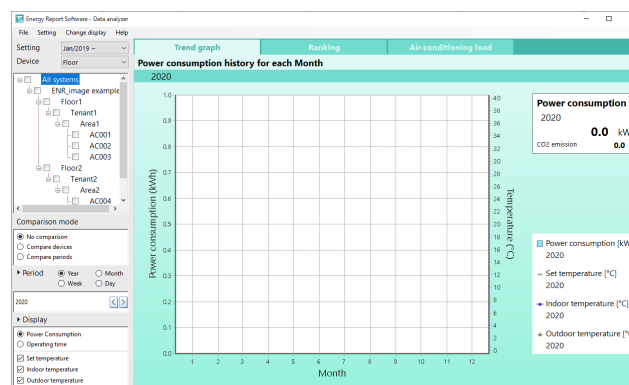

Troubleshooting

If you are unable to download, refer to P.41.

Updating Data

You can download the data that the system controller has aggregated and update the graph and report to be displayed. Select [File]→[Retrieve latest data]. A dialogue box appears.

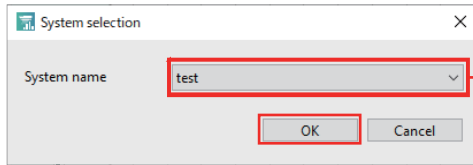

Select the model that has the data you want to download, and click the [OK] button.

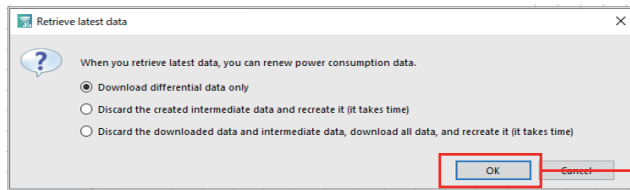

Click the [OK] button to start downloading the data.

Download differential data only	Download only the difference data between the controller and this software.
Discard the created intermediate data and recreate it (it takes time)	Delete only the intermediate file of this software and recreate the intermediate file without downloading. (usually not used)
Discard the downloaded data and intermediate data, download data, and recreate it (it takes time)	Delete the downloaded files and intermediate files of this software, download the controller data, and recreate the intermediate files. (usually not used)

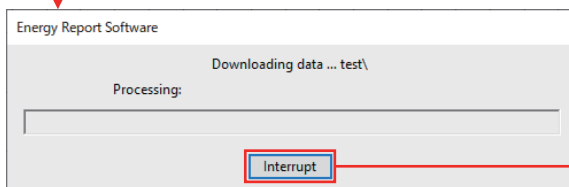

If the download is interrupted, partially downloaded data will be deleted.

Troubleshooting

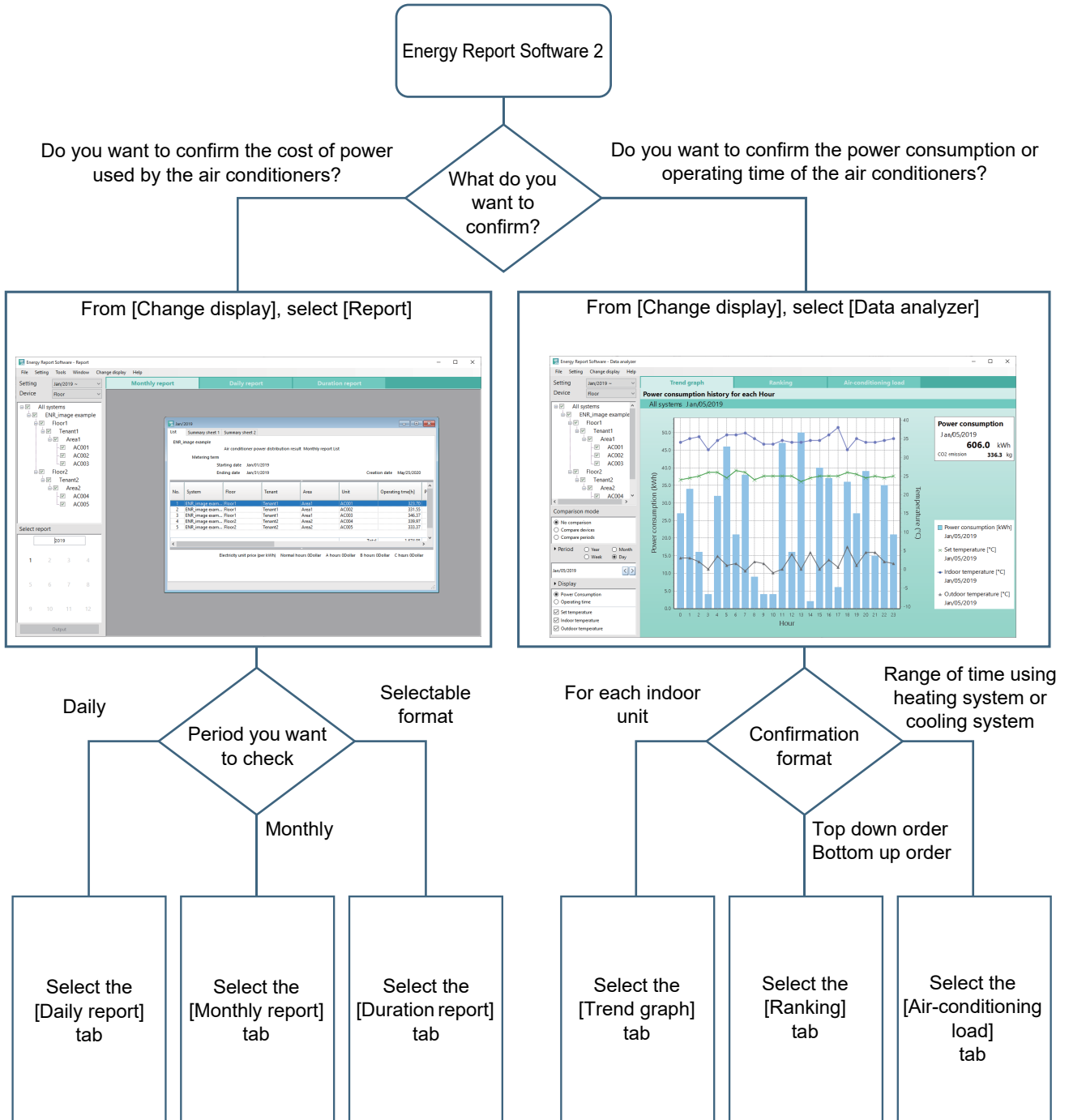

If you are unable to download, refer to P.41.

10 Summary of Screens for Each Mode

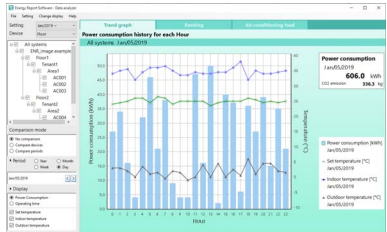

Data analyzer Screen

On the “Data analyzer” screen, you can create graphs from the data of the selected indoor units and view them on the screen. You can easily make comparisons against past data or in units of groups (such as floors or tenants). The data analyzer has three display modes: [Trend graph], [Ranking] and [Air-conditioning load].

Screen name	Description	Screen	Reference
Trend graph	<p>With [Trend graph], you can display the power consumption or operating time of the indoor units selected in the device selection tree in a graph. You can choose from three comparison modes: [No comparison], [Compare devices] or [Compare periods].</p>		P.20
Ranking	<p>With [Ranking], you can display the ranking of the power consumption or operating hours of the indoor units selected in the device selection tree.</p>		P.22
Air-conditioning load	<p>With [Air-conditioning load], you can compare the total air-conditioning load of the indoor units selected in the device selection tree within the selected period. This is useful for checking at what level the installed indoor units are operating compared to their rated capacity. You can choose from three types of graphs depending on the “Comparison mode” in the menu: [No comparison], [Compare devices] or [Compare periods].</p>		P.23

Report Screen

On the Report screen, you can use data from the selected indoor units to create monthly or daily reports, or reports that aggregate data from a selected period (Duration reports). You can also output aggregated reports in Excel, CSV, or PDF format.

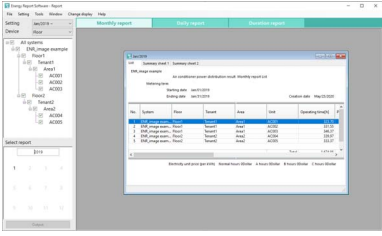
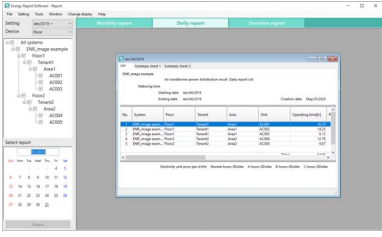
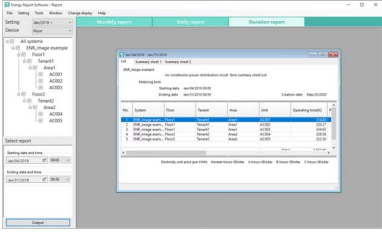
Screen name	Description	Screen	Reference
Monthly report	You can create and display a monthly report for each specified month.		P.26
Daily report	You can create and display a daily report for each specified day.		P.26
Duration report	You can create and display reports that cover the period from the selected starting date and time to the selected ending date and time.		P.26

11 Data Analyzer

In "Data analyzer" mode you can view graphs of the history of operating power consumption or operating time for the indoor units managed by the system controller. You can visually check the operating efficiency of the indoor units by making comparisons against past data from the same indoor units or comparing the operation data against other indoor units or in groups such as by floor or by tenant.

Also, if you have improved the way that the indoor units are used, such as by using low energy priority operation (Save operation or demand control) on the system controller side, or by changing the setting temperature depending on the situation, you can create a graph and check the energy-saving effect.



Screen mode	Comparison mode	Description	Reference
Trend graph	No comparison	You can check the time spans when power consumption is high and investigate how efficiency is related to ambient temperature.	P.20
	Compare devices	Comparisons of units or groups are displayed as 3D graphs. You can also compare the operating time of different devices.	P.21
	Compare periods	You can compare the power consumption or operating time for a specific period. You can compare power consumption against the previous year or previous day.	P.22
Ranking	-	Displays the power consumption or operating time of the indoor units selected in the device selection tree as a ranking.	P.22
Air-conditioning load	No comparison	-	P.23
	Compare devices	Comparisons of units or groups are displayed in 3D. You can also compare the operating time of different devices.	P.23
	Compare periods	With Compare periods, you can compare the air-conditioning load for a certain period for specified units or groups. You can compare power consumption against the previous year or previous day.	P.24

Detailed Description of the Data Analyzer Screen

Data Analyzer screen: Device selection tree, Period and Display

<Device selection tree>
Shows the indoor units that can be displayed in a graph.
The tree structure display is based on the data downloaded from the connected system controller.

[Period]
You can choose the period to be displayed in the graph from [Year] 1 year, [Month] 1 month, [Week] 1 week, or [Day] 24 hours.

[Display]
You can choose the items that are shown in the graph area for each screen mode.

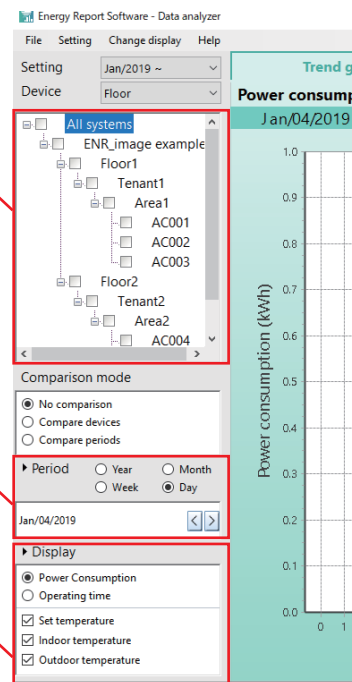

Select the period to display in the graph

You can choose the period to display in the graph. Click [Period] to display the “Set Period” dialogue box.

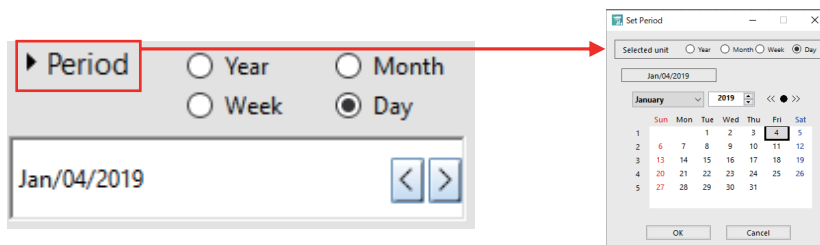

In [Compare periods] mode, the following dialogue box appears.

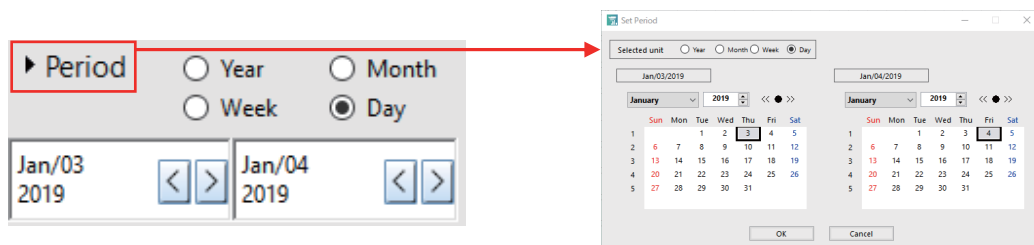

* In this software, week 1 means the first week of the year that starts with the [Calendar start day of the week] set in [Software setting].

Changing the graph display

You can change the graph display settings.

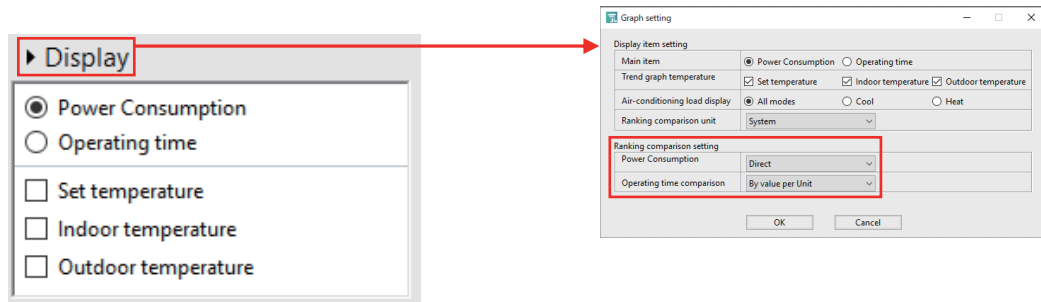

Ranking comparison setting

You can change the detailed settings for [Ranking], [Power Consumption] and [Operating time].

You can choose from the following two types of [Power Consumption] comparison:

- [Direct] Total power consumption of selected devices (groups)
- [By unit amount value] Power consumption per horsepower of selected devices (groups)

You can choose from the following types of [Operating time] comparison:

- [Direct] Total operating time of selected devices (groups)
- [By value per Unit] Operating time (average) per unit of selected devices (groups)
- [Maximum] Maximum operation time per unit of selected devices (groups)

Description of Screens

Trend graph

On the [Trend graph] screen, you can display a graph of the [Power Consumption] or [Operating time] of the indoor units selected in the device selection tree.

Comparison mode: [No comparison]

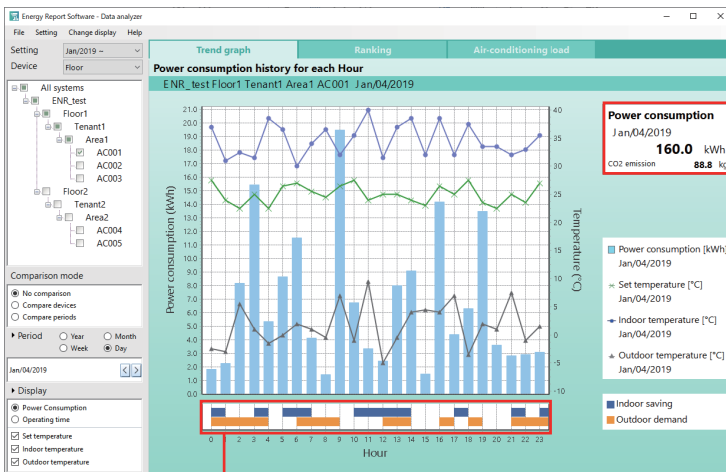

For [Power Consumption], both the graph total value and CO₂ emissions are shown to one decimal place when they are less than 1000.
 For [Operating time], two decimal places are shown when the value is less than 1000.
 Decimal places are not shown when the value is 1000 or above.
 Also CO₂ emissions are not shown.

The operating state is only shown when only one indoor unit is selected in the device selection tree and when the Set Period unit is [Day]. This is described below.

- The time spans when the indoor unit is in <Save> mode are shown in blue.
- When the indoor unit is a multi-indoor unit, the time spans when the connected outdoor unit is in <Demand> mode are shown in orange.

Trend graph link function

If you wish to view a detailed graph of the [Power Consumption] or [Operating time] shown in the graph, click on the bar of interest to view a detailed graph. Refer to the table on the right for graphs that can be viewed. Note that the settings for the displayed temperature graph cannot be changed.

Display graph	Graph that displays after clicking
[Year]	Clicked month
[Month]	Clicked day
[Week]	Clicked day
[Day]	No link function

Comparison mode: Compare devices

“Comparison mode”: [Compare devices] displays a 3D graph that compares units or groups. You can also compare devices by operating time.

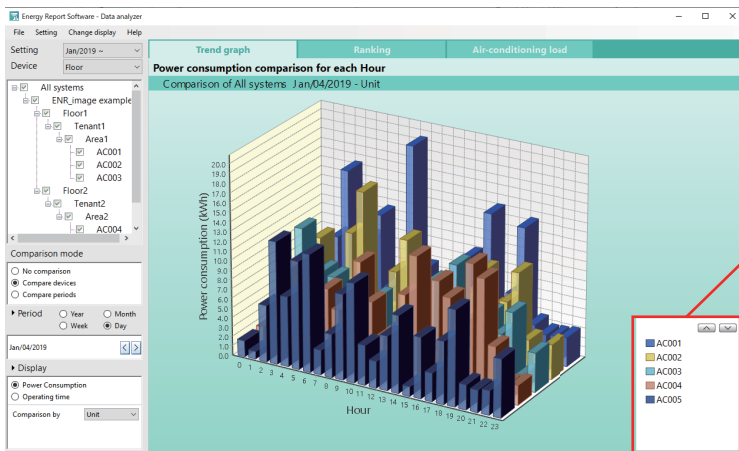

If you wish to change the display order of the 3D graph, choose the item by clicking it, then use the buttons to change the order. Up to 8 items can be displayed.

Changing the perspective of the 3D graph

You can change the perspective of the 3D graph by holding down the left mouse button in the upper part of the graph and then moving the mouse.

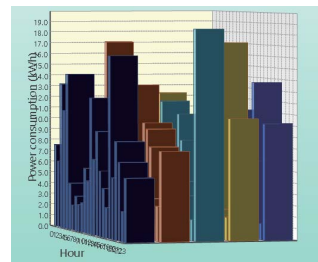
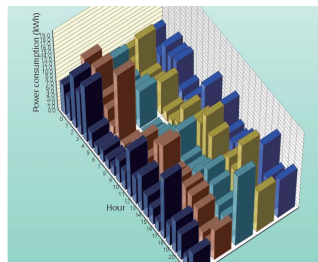
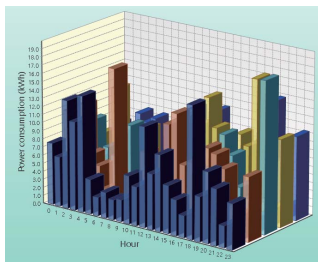

Comparison mode: Compare periods

“Comparison mode”: [Compare periods], you can compare [Power Consumption] or [Operating time] for a specific period. Compare the base data (grey graph) and comparison data (light blue graph).

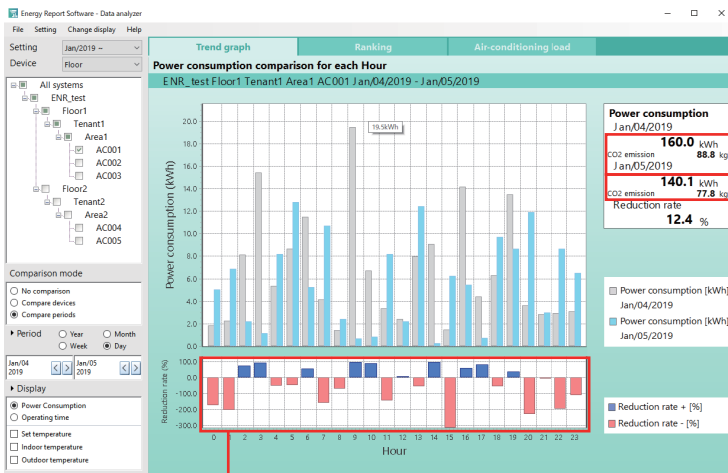

This area shows the reduction rate of the comparison data compared to the base data. If the reduction rate is positive, the graph is shown in blue, and if it is negative it is shown in red.

For [Power Consumption] both the graph total value and CO₂ emissions are shown to one decimal place when they are less than 1000. For [Operating time] two decimal places are shown when the value is less than 1000. Decimal places are not shown when the value is 1000 or above. Also CO₂ emissions are not shown. The upper red frame is the base data and the lower red frame is the comparison data. *

- * If there is no base data or if it is 0, the reduction rate is displayed as “-”.
- * If the reduction rate is less than -999.9%, it is displayed as “-”.
- * If there is no comparison data, it is displayed as “-”. If the data was zero, the reduction rate is displayed as 100%.

Ranking

With [Ranking], you can display the ranking of the power consumption or operating hours of the indoor units selected in the device selection tree.

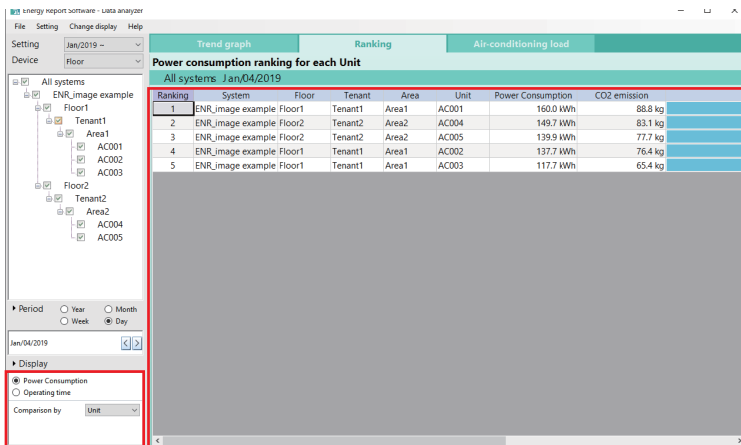

If you wish to display a trend graph of a unit or group shown as a ranking, click the unit or group item you wish to display. The chosen unit or group is displayed as a trend graph. *

- * Temperature graphs are displayed with the settings that were displayed previously in the trend graph.

You can change the settings of [Ranking]. For details, see P.19. CO₂ emission display: When [Power Consumption] is selected as the main display item, the CO₂ emission value is displayed. For details on changing the emission factor settings, see P.39.

Air-conditioning load

Comparison mode: No comparison

The ratio to operating time is displayed as a bar graph. The contents are shown separately for the cooling system (blue) and the heating system (orange).



The operating time ratio for operating modes is shown for the selected time period.
 "Cool" The total value of the operating time ratio of <Cool>, <Dry> and <Auto Cool>.
 "Heat" The total value of <Heat> and <Auto Heat>.
 "Fan" The total value of <Fan>.

Vertical axis: "Operating time ratio"
 Horizontal axis: Air conditioning load level (up to 11 levels)

Comparison mode: Compare devices

"Comparison mode": In [Compare devices] a comparison of units or groups is shown as a 3D graph.

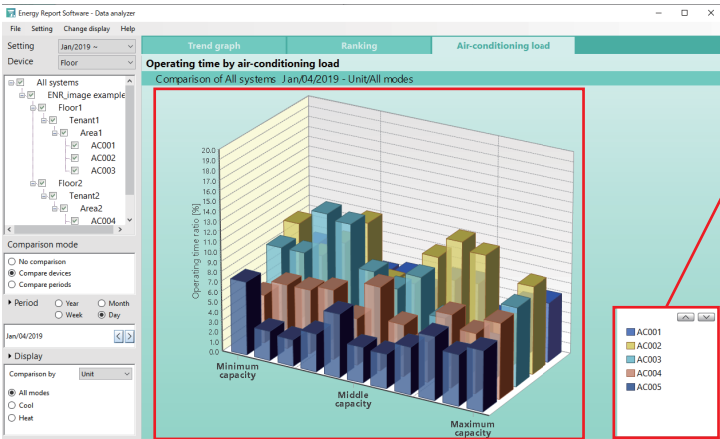

If you wish to change the display order of the 3D graph, choose the item by clicking it, then use the buttons to change the order. Up to 8 items can be displayed.

Vertical axis: "Operating time ratio"
 Horizontal axis: Air conditioning load level (up to 11 levels)

Comparison mode: Compare periods

“Comparison mode”: In [Compare periods] the air-conditioning load for a certain period can be compared for specific units or groups.

Compare the base data (grey graph) and comparison data (light blue graph).

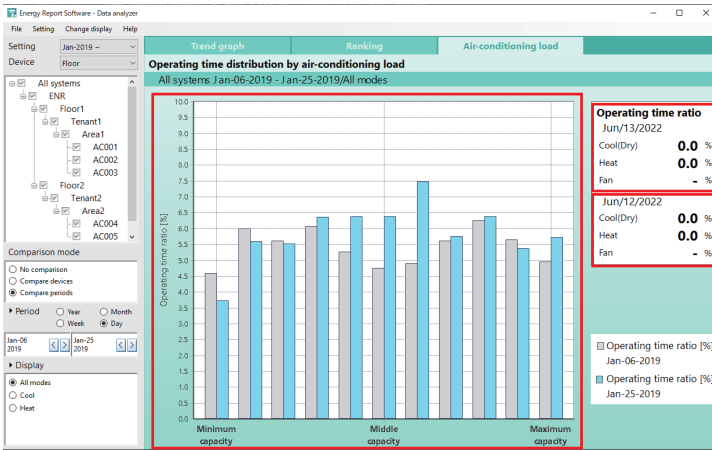

The operating time ratio for operating modes is shown for the selected time period.

“Cool” The total value of the operating time ratio of <Cool>, <Dry> and <Auto Cool>.

“Heat” The total value of <Heat> and <Auto Heat>.

“Fan” The total value of <Fan>.

The upper red frame is the base data and the lower red frame is the comparison data.

Vertical axis: “Operating time ratio”
 Horizontal axis: Air conditioning load level (up to 11 levels)

Data Analyzer

Print a graph

You can print graphs shown on the screen. (A printer must be connected to your computer.)

1. Select [Print] or [Batch Print] from [File] on the menu bar to display the Print preview screen.

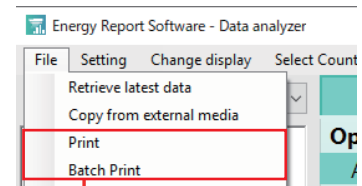

2. Click the print button  (shown in the red frame). Print according to the printing method of the installed printer.

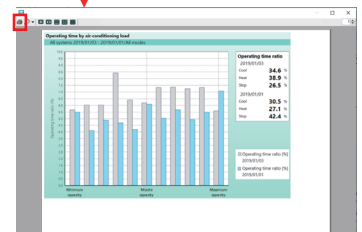

If you select [Batch Print], the Batch print screen appears. Select one or more item then click the [OK] button. The Print preview screen appears. Print according to step 2.

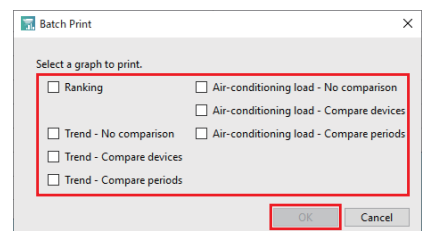

12 Reports

On the Report screen, reports are created based on the operating results of each indoor unit measured by the system controller. In addition to the function to create Reports, there is a function to create Billing Schedules.

The function to create Reports calculates the charge for each indoor unit based on the amount of electricity used and the electricity unit price for each indoor unit.

Reports can be output Excel, CSV / TSV, or PDF file format.

Classification										Result	
No.	System	Floor	Tenant	Area	Unit	Operating time[h]	Power [kWh]	Normal hours		A hours	
							Operating time[h]	Power [kWh]	Operating time[h]	Power [kW]	
1	ENR_image example	Floor1	Tenant1	Area1	AC001	10.10	159.98	2.35	28.08	2.53	
2	ENR_image example	Floor1	Tenant1	Area1	AC002	14.25	137.66	3.30	28.17	3.15	
3	ENR_image example	Floor1	Tenant1	Area1	AC003	8.13	117.75	1.18	31.92	1.97	
4	ENR_image example	Floor2	Tenant2	Area2	AC004	12.78	149.69	4.72	34.65	2.18	
5	ENR_image example	Floor2	Tenant2	Area2	AC005	9.67	139.92	1.60	21.18	3.42	
Total						54.93	705.00	13.15	144.00	13.25	

Basic Operation Method

This section describes the basic operation method of the "Report" screen.

<Device selection tree>
 The indoor units that can be output to a report are shown.
 The tree structure display is based on the data downloaded from the connected system controller.

Select the indoor unit, then select the period from the period area. Click the [Output] button to output the report.*
 * Greyed out months and days cannot be selected.
 * The date with an underscore (_) is the monthly report ending date.

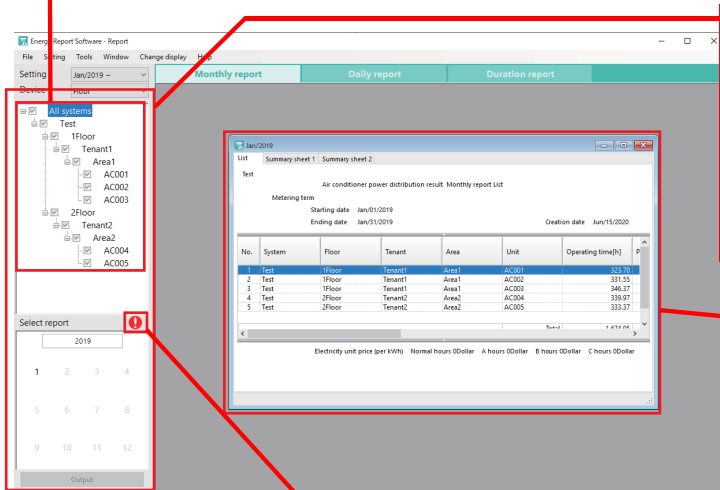

"Report" window
 Window showing the reports that have been output on each screen.
 The data for the indoor unit selected in the device selection tree is displayed.

This icon is displayed when there is a period with no data for the indoor unit or power meter.
 (System controller power failure, etc.)
 Click it to display the periods with no data.

Notice

When all settings are selected, an automatic download report is output. However, duration reports are not output.

Monthly report

Display the [Monthly report] screen and select the indoor unit from the device selection tree.

From the calendar, select the month for which you want to output a monthly report, then click the [Output] button.

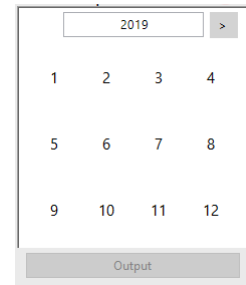

Daily report

Display the [Daily report] screen and select the indoor unit from the device selection tree.

From the calendar, select the day for which you want to output a daily report, then click the [Output] button.

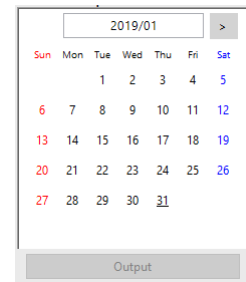

Duration report

If you want to view a report for a specific period, display the Duration report screen and click the icons shown in the red frames.

Select the starting date and time and ending date and time from the calendar that appears.

After you have selected the dates and times, click the [Output] button.*

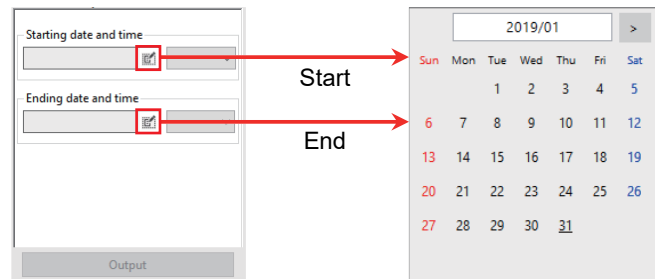

*The starting time can be set in one hour increments from 00:00 to 23:00 and the end time in one hour increments from 01:00 to 24:00.

Report window

The reports that have been output on each screen are shown in the Report window.
The following describes the screen layout of the Report window.

<Summary sheet tab>
 [List] Displays a list of the selected indoor units.
 [Summary sheet 1] Displays the total value for the set group.*
 [Summary sheet 2] Displays the total value for the set group.*
 * Group settings can be changed in [System setting] → [Report setting] tab.

<Report>
 Each item of the summarized data is shown for each indoor unit.*
 * Item settings can be changed in [Software setting] → [Report setting] → [Item].

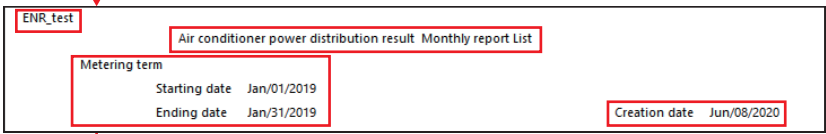
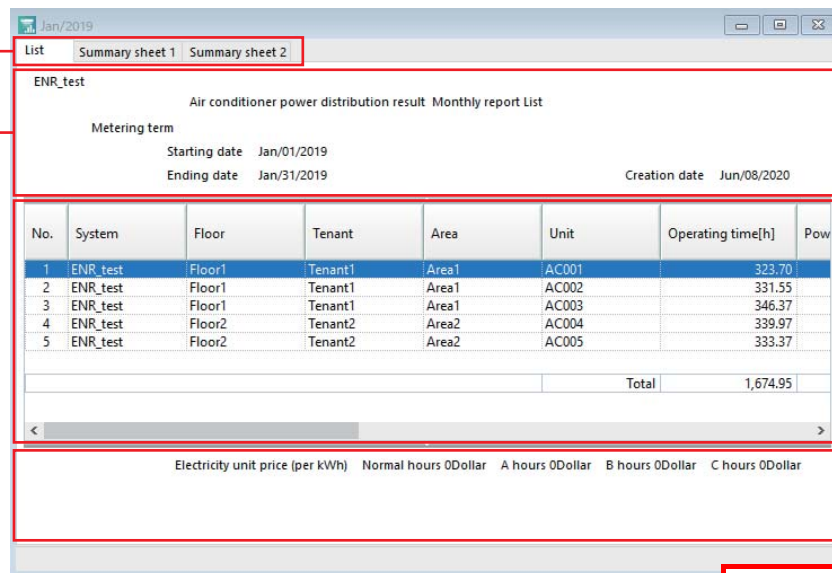

<Footer>
 The footer shows the electricity unit price.

<Header>
 The header shows the following:

- Name of selected system
- Air conditioner electric power distribution result [Monthly report] / [Daily report] / Period total, [List] / [Summary sheet 1 / 2] (Example) In the case of a list created on the [Monthly report] screen, "Air conditioner power distribution result Monthly report List".
- "Metering term"
- Report creation date

Billing Schedule

The Billing Schedule is a schedule that can be set when the charging rate is different for different time spans or days. To use the Billing Schedule, it is necessary to save the Billing Schedule setting information and the Billing Schedule registration information.

Notice

When you set the Billing Schedule, the setting content is applied to the data after the time of the last data update before the setting.

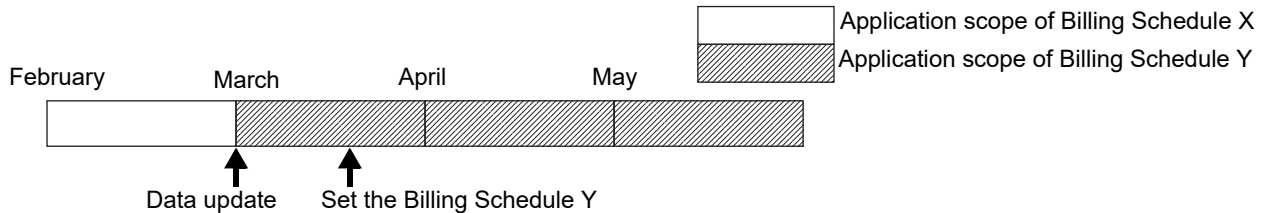

When setting the Billing Schedule, the scope to which it is applied varies depending on the time of the last data update before the setting.

Example: To apply the Billing Schedule Y from the time and date shown by the ↑ in the figure below, update the data (1) just before setting the Billing Schedule Y. Then, set the Billing Schedule Y (2).

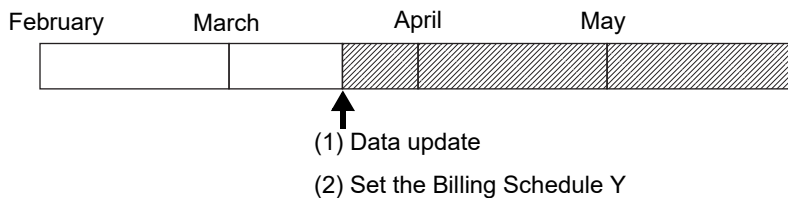

In this software, the power consumption and operating time distribution is calculated based on the Billing Schedules set for each hour. If a Billing Schedule has been set or changed, the calculation is performed again according to the set schedule from the "00" minutes of the hour of the last data update before the Billing Schedule has been set.

Example: If you have set the Billing Schedule Y at 11:30, the time span from 11:00 to 12:00 is calculated with the Billing Schedule Y.

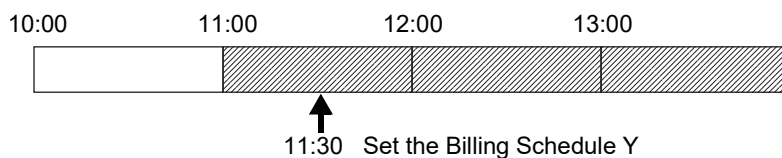

In the Billing Schedule you can set time spans as "A / B / C / Normal hours"

Example: If you set 09:00 to 12:00 as "A hours", 13:00 to 18:00 as "B hours", and 18:00 to 21:00 as "C hours", the billing time spans for one day will be as follows.

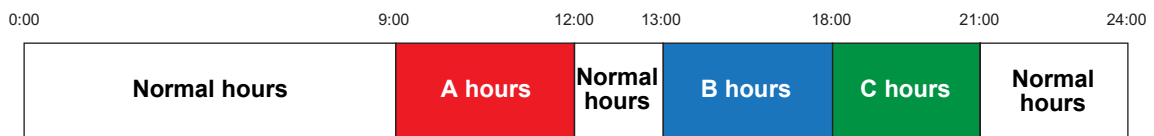

You can set the daytime charging rate for B hours and the night-time charging rate for C hours. For details on setting the charging rate, refer to P.39.

The procedure for setting the Billing Schedule is as follows:

- (1) Download the system controller settings
Download the settings for the system controller.
- (2) Set Billing Schedule to Unit
Register the Billing Schedule to be used for each indoor unit and set the Billing Schedule.
- (3) Create Billing Schedule
If you want to register a regular weekly schedule and a Billing Schedule that is different from the weekly schedule, create a schedule for a Special Day.

How to Set the Billing Schedule

Select the device for which you want to set the Billing Schedule and select [Edit] → [New] on the menu bar or click the  icon to display the Billing Schedule name input dialogue box.

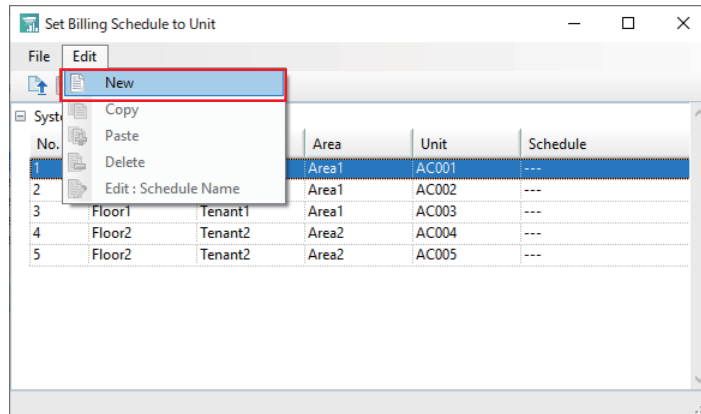

Enter the Billing Schedule name in the Billing Schedule name input dialogue box and click the [OK] button.

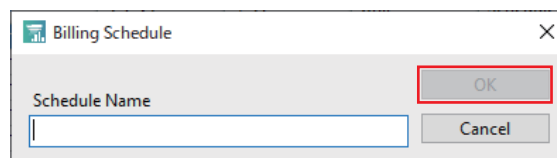

Double-click on the name of one of the registered Billing Schedules to display the Billing Schedule creation screen.

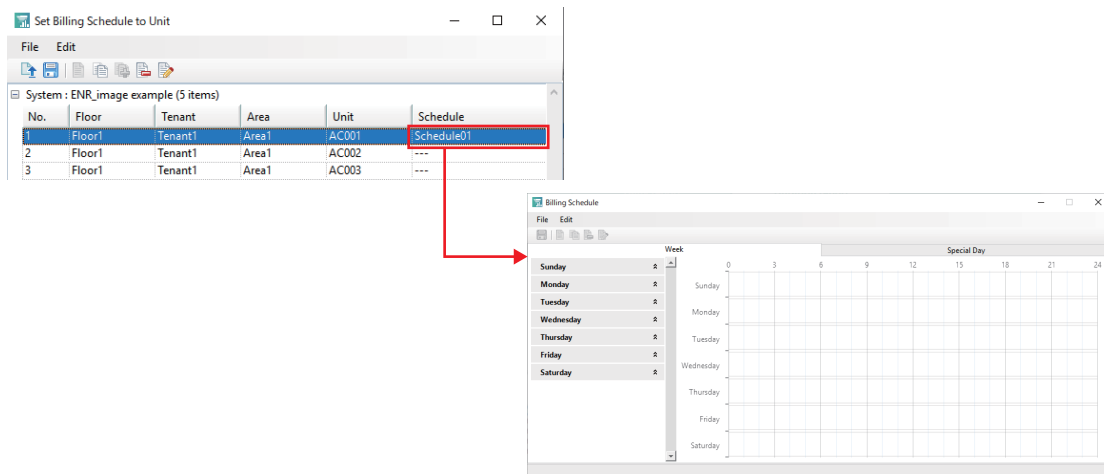

Creating a Billing Schedule

Select the day of the week or the Special Day for which you want to create a schedule, and select [Edit] → [New] on the menu bar or click the  icon.

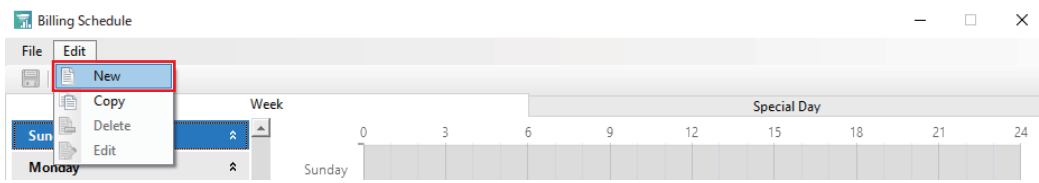

After clicking, the pop-up screen for registering the schedule time appears as shown below. After setting the start time and end time, select either the A, B, or C hours time span and click the [OK] button.*

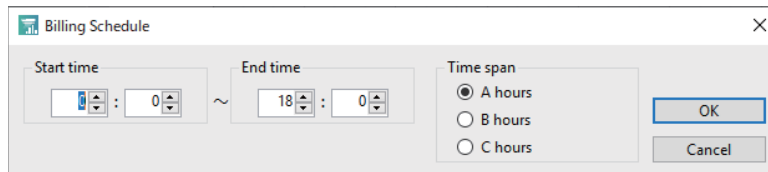

- * Multiple time spans cannot be set at the same time. Hours not included in A / B / C hours will be designated as Normal hours.
- * As shown in the figure below, if the set schedules of A / B / C hours overlap, they cannot be set.

(Example) B hours 09:00 to 12:00
 C hours 11:00 to 18:00

In the above case of schedule setting, the hours cannot be set because the time from 11:00 to 12:00 overlaps.

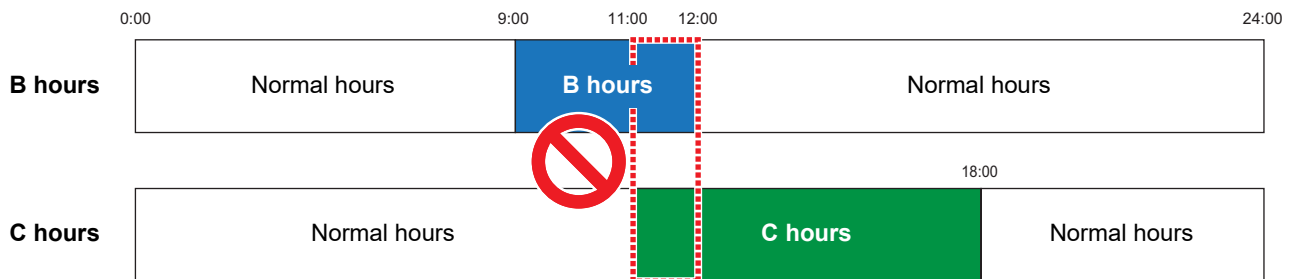

For a Special Day, select the date on the calendar after setting the Billing Schedule.

Saving Billing Schedule settings

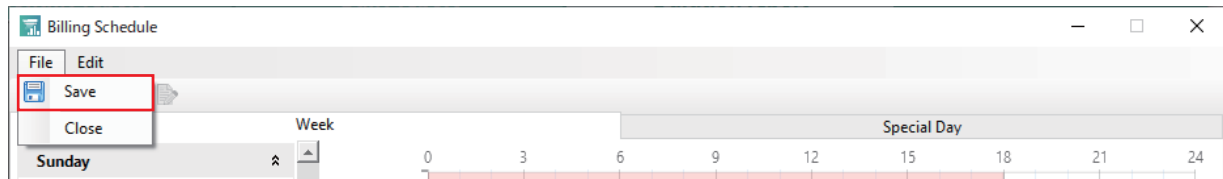

After creating the Billing Schedule, select [File] → [Save] on the menu bar or click the  icon to save the settings.

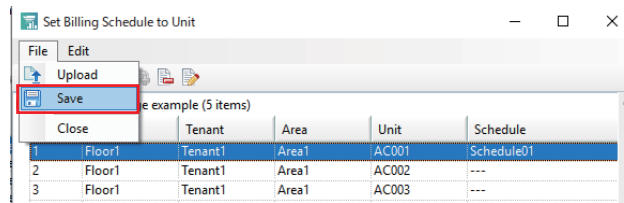

After that, select [File] → [Save] on the menu bar or click the  icon to save the settings for the Billing Schedule created on the Billing Schedule registration screen.



Copy Billing Schedule

Select the row in which the schedule is registered on the Billing Schedule registration screen, and copy it by selecting [Edit] → [Copy] on the menu bar or click the  icon. After that, paste it by selecting [Edit] → [Paste] on the menu bar or click the  icon.*

* When copying the Billing Schedule, be sure to create the Billing Schedule before copying it on the Registration screen. If you copy without creating a Billing Schedule, changes in the schedule of the copy origin will not be reflected in the copy destination.*

13 History

Check Code History

You can display failures that have occurred in a list, including currently occurring ones. This can be used for grasping the status of the site such as investigating the cause of a failure and the recovery status.

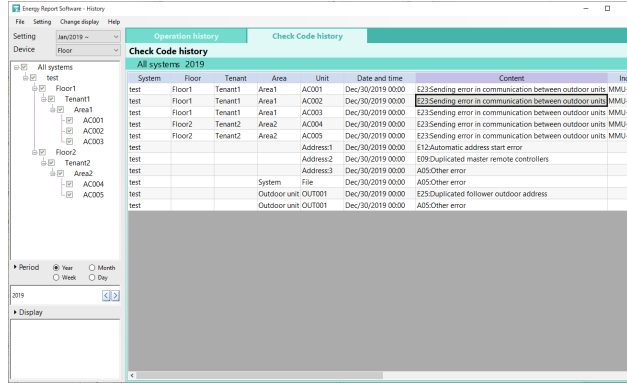

Operation History

The Operation history screen shows the history of the operations performed in the software.

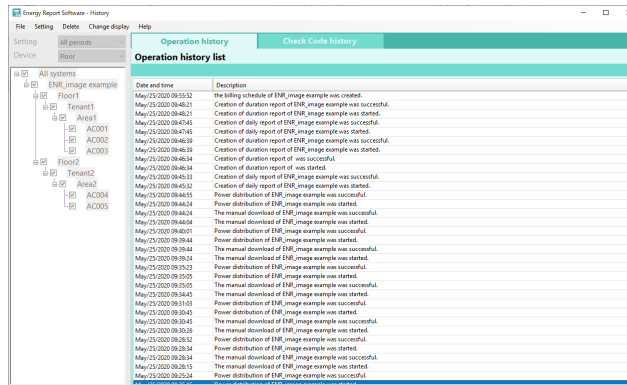

History Screen Menu Bar

This section describes the menu bar that is only displayed on the "History" Screen.

It is an item in the [Delete] menu bar.

Item	Function	Remark
Delete selected history	Delete the operation history for the selected row.	Only the operation history can be deleted.
Delete all	Delete all operation history.	

14 Various Settings

Software Setting

This screen is for adjusting detailed settings related to the software. Three tabs are displayed: [General], [Report] and [Data analyzer].

For details of these items, see P.37.

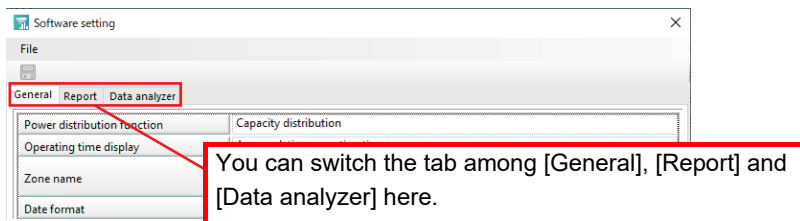

System Setting Screen

In the system settings, you can register and set the system controller to which the software is connected.

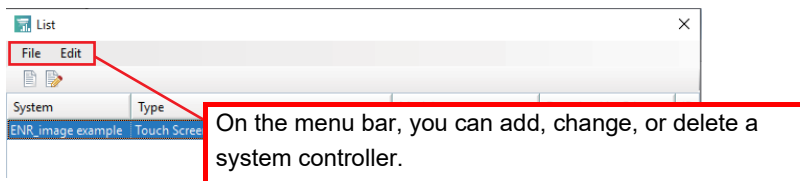

System Registration Screen

On the “System Registration” screen, you can register the settings of the system controller connected to the software.

System	
Type	Touch Screen Controller(CT128/256series)
Model	BMS-CT2560U-E/-TR
Download by Ethernet	<input checked="" type="checkbox"/>
IP address	192.168.2.80
Automatic download	<input type="checkbox"/>
Time of automatic download	00:31
Usage of power meter at power distribution	Distribute separately

“System” Enter the name of the system controller to be registered.
 “Type” Select the system controller type.
 “Model” Select the system controller model.
 “IP address” Enter the system controller IP address.

Checking the Connection on the System Registration Screen

You can check the connection with the system controller by selecting [Run] → [Check the Connection] on the menu bar or click the  icon. The images below show the display when the connection was successfully confirmed and when the connection failed.

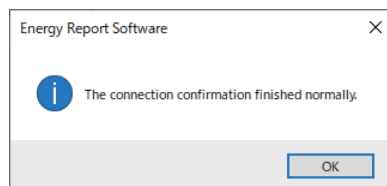

Normal

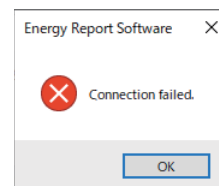

Error (example)

Troubleshooting

If the connection check fails, refer to P.41.

User Setting

On the User setting screen, you can set or change the username and password used to log on to the software.

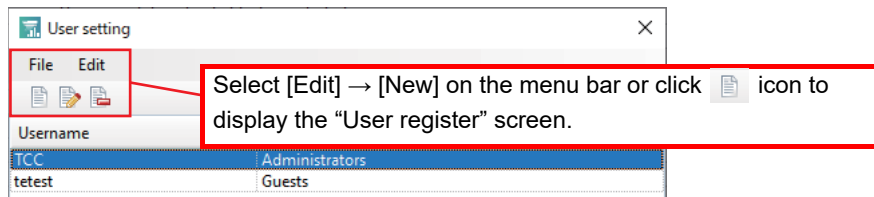

User Register Screen

On the "User register" screen, you can input and register user information.

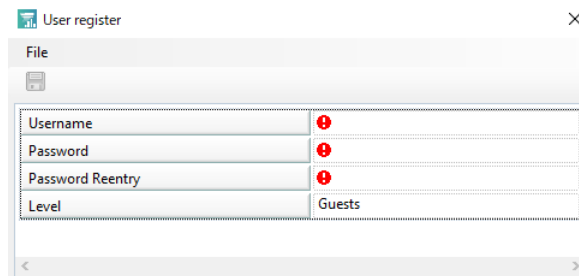

Troubleshooting

If you cannot register the user information, refer to P.41.

Table of User Levels

The table below describes the differences between the "Administrators" and "Guests" levels which are set during user registration.

Function		Administrators	Guests
Log on		✓	✓
Report	Monthly report	✓	✓
	Daily report	✓	✓
	Duration report	✓	✓
	Billing Schedule	✓	-
Data analyzer	Trend Graph	✓	✓
	Ranking	✓	✓
	Air conditioning load	✓	✓
History	Check Code history	✓	✓
	Operation history	✓	✓ (Cannot be deleted)
Software setting		✓	-
System setting		✓	-
User setting		✓	-
Help		✓	✓
Version		✓	✓

15 Troubleshooting

When Adjusting Detailed Settings or Making Changes

What you want to set	Screen	Explanation
I want to output a data analyzer graph as an image.	"Data analyzer" screen → Menu bar [File] → [Capture]	Select the item to export the graph screen as an image. The save destination is "(data save folder)\user\(\log on username folder)\capture". You can confirm the data storage folder location at [Software setting] > [General] tab > [Data save folder].
I want to paste a data analyzer graph to another application.		Select the item and press [CTRL] + V or right-click and select [Paste] to paste to the desired location in the other application.
I want to export a graph as a CSV file.	"Data analyzer" screen → Menu bar [File] → [Export data]	Select the item. The "Save As..." dialogue box appears. Give the item a name and save it.
I want to save the graph display settings.	"Data analyzer" screen → Menu bar [File] → [Save settings]	You can save the graph display settings. Select the item. The "Save As..." dialogue box appears. Give the item a name and save it.
I want to apply the saved graph display settings.	"Data analyzer" screen → Menu bar [File] → [Save settings]	Select the item. The "Open" dialogue box appears. Select the saved graph display setting file. The saved settings are applied.

What you want to set	Screen	Explanation
I want to download the system controller data using a USB memory device.	"Report" screen → Menu bar [File] → [Copy to external media]	<p>The selection screen for the data exported from the system controller to the USB memory device appears. From among the folders saved in the USB memory device connected to the PC, the UsbExport_yyyymmddHHMMSS folder appears.</p> <p>yyyy: year mm: month dd: day</p> <p>Select the exported data and click the [OK] button to display graphs and reports.</p> <p>For the procedure to export data from the system controller to a USB memory device, refer to the instruction manual for the system controller.</p>
I want to change the zone names.	[Software setting] → [General] tab	<p>You can change zone names by directly entering them in the "Zone name".</p> <ul style="list-style-type: none"> • [Zone 1] (default: [Floor]) • [Zone 2] (default: [Tenant]) • [Zone 3] (default: [Area])
I want to change the date format.		You can change this from the "Date format".
I want to change the temperature units.		<p>You can select from the following two units in the "Temperature settings".</p> <ul style="list-style-type: none"> • °C • °F
I want to change the save location of downloaded data.		You can change this from the "Data save folder".
I want to change the language.		<p>Select a language from the "Language".</p> <p>After selecting, restart the software.</p>

What you want to set	Screen	Explanation
I want to select the file format of the monthly or daily report to be output.		You can set the following three types of file format in the "Report file format". <ul style="list-style-type: none"> • csv • xlsx • pdf
I want to change the items displayed in the Report section of the Report window.	[Software setting] → [Report] tab	In "Item" you can select from the following eight items to display in "List", "Summary sheet - 1" or "Summary sheet - 2". <ul style="list-style-type: none"> • [Operating time] • [Electric power] • [Charge] • [Charge including tax] *It cannot be selected in "List". • [Normal hours display] • [A hours display] • [B hours display] • [C hours display]
I want to select the group to be summarized in [Summary sheet 1].	[Software setting] → [Report] tab	You can select from "Categories of Summary sheet - 1". You can select from [Floor], [Tenant], [Area] and [Refrigerant system]. You can only select [Refrigerant system] when [Proportion within refrigerant system] is selected as the distribution result.
I want to select the group to be summarized in [Summary sheet 2].		You can select from "Categories of Summary sheet - 2". You can select from the items other than the item selected in "Categories of Summary sheet - 1" or "None".
I want to change the currency in which the charge is displayed.		You can change the currency displayed in the "Currency name".
I want to show the charge with decimal places. Or, I do not want to show decimal places.		You can select from the following two types in the "Subordinate currency unit". <ul style="list-style-type: none"> • [None] • 1/100
I want to set the tax rate.		You can set the tax rate to be applied to the charge in the "Tax rate".

What you want to set	Screen	Explanation
I want to output a report of the usage rate rather than the electric power of each indoor unit.	[Software setting] → [Report] tab	You can select from the following two types in the “Distribution result”. <ul style="list-style-type: none"> • [Electric power] • [Proportion within refrigerant system]* <p>* It displays the percentage that each indoor unit is using in the same refrigerant system. The usage rate changes depending on the set temperature and the indoor temperature.</p>
I want to change the operating time display or units.		You can select from the following three types in the “Operating time format”. <ul style="list-style-type: none"> • [Hour] • [Hour and minute] • [Minute] <p>(Example) When operating for 1 hour Hour: 1 [h] Hour and minute: 1 [h] 00 [m] Minute: 60 [m]</p>
I want to set the unit price for the electricity consumed during normal hours and A / B / C hours.		You can set the electricity bill unit price for each time span from “Electricity bill unit price for 1 kWh” in “Charging rate settings”.
I want to display an electric power graph without using a power meter.	[Software setting] → [Data analyzer] tab	By setting the “Graph display setting of estimated power”, you can display the electric power of each indoor unit from the estimated electric power obtained from the outdoor unit. <ul style="list-style-type: none"> * Some outdoor units do not support estimated electric power. * Do not set this parameter when a power meter is connected. Otherwise, the electric power graph may not display properly.
I want to change the month comparison setting.		You can select from the following two types in the “Month comparison setting”. <ul style="list-style-type: none"> • [Compare the same dates] • [Shift the dates to align the days of the week]
I want to set the CO ₂ emission factor.		You can set this by directly inputting in the “CO ₂ emission factor setting [kg/kWh]”.

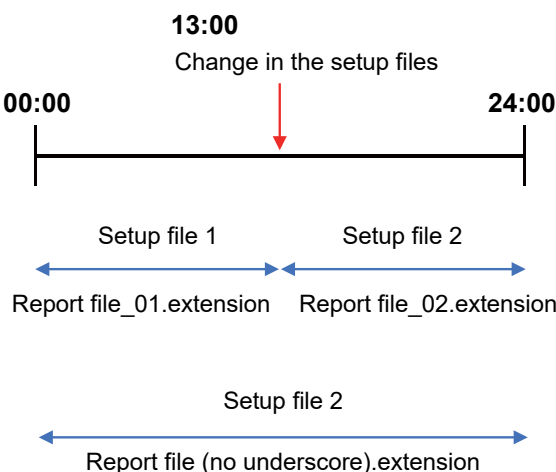
<p>I want to automatically download data from the system controller.</p>	<p>[System setting] → [System registration] screen</p>	<p>You can set this in the “Automatic download”.</p> <p>* Notes on the Automatic download feature</p> <p>Automatic download is executed only when the PC on which the software is installed is running.</p> <p>If the controller setup file has been changed using the Setup file creation software 2 (SFC2) or the Section setting software (SCS), the report files for the day and the month of the change are separated as follows.</p> <p>Daily report file name_01.extension (before the change) Daily report file name_02.extension (after the change)</p> 
<p>I want to set the time for Automatic download.</p>		<p>You can set the time for Automatic download in the “Time of automatic download”.</p>
<p>To change the setup file</p>		<ol style="list-style-type: none"> 1. Output the required reports before the change. 2. Upload the setup file after the change. 3. Reports are created based on the setup file after the change from this point.

When a Problem Occurs

Phenomenon	No.	Question	Items to check or notes
I cannot install the software.	1	Are you using the specified OS on the PC?	Windows 10 and Windows 11 are supported.
	2	Does the logged-in Windows user account have administrator privileges?	This software cannot be installed with an account that does not have administrator privileges. Please install with an account that has administrator privileges.
	3	Does your computer have enough free space?	This software cannot be installed if there is not enough free space. Increase the free space to 500 MB or more before attempting to install the software.
Logon failed.	4	Are the username and password correct?	You cannot log on if the username or password is incorrect. The username and password are case-sensitive. If you registered them with upper-case letters, you must enter them in upper-case letters.
Data download failed. Connection check failed.	5	Did you check the connection with the PING button?	Check the connection referring to P.34. If it fails, check 6, 7, and 8. If you can connect, check 9 and 10.
	6	Is the LAN cable connected?	Are the system controller and LAN cable connected?
	7	Did you change the IP address of the system controller?	If you have changed the IP address of the system controller, you must also change the system registration information.
	8	Have you set the IP address of your PC?	Check the network settings of your PC.
	9	Are the details of the connected model correct?	Check the registered type and model on the System registration screen.
	10	Is the port open?	Check if the port described in P.8 is open.
	11	After trying 5 to 10, are you still unable to download or upload?	If the problem is not resolved even after trying the above items, please contact your PC or network administrator.
I cannot register user information.	12	Did you enter a username that has already been registered?	You cannot register the same username twice. Please register with a different username. Also, you cannot register with a username that only includes numbers.

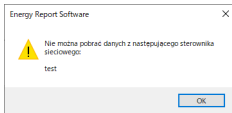

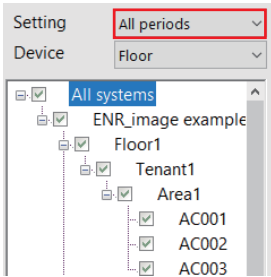
Phenomenon	No.	Question	Items to check or notes
<p>The layout of the device selection tree has changed.</p>	<p>13</p>	<p>Did you change the system configuration?</p>	<p>If you change the system configuration during operation, such as by adding or deleting indoor units, the tree layout may also change. For this reason, you can switch the tree layout and display data by selecting the set period for the tree layout from the combo box.</p> <p>If there are installations with different configurations within the selected period of the graph, a combo box will appear above the tree.</p> <p>* If there is no change in the configuration, the combo box is not displayed.</p> 
<p>I do not know what the save destination is for output report files.</p>	<p>14</p>	<p>Check [Software setting] → [General] tab → Data save folder</p>	<p>The save destination for report files is “(Data save folder)\report\”. The files are separated as follows depending on the output method.</p> <p>Automatic reports: Data folder\user\user name\report\auto\system name</p> <p>Manual reports: Data folder\user\user name\report\manual\</p> <p>The files are further separated as follows.</p> <p>Monthly reports: Saved in the Month folder Daily reports: Saved in the Day folder Duration reports: Saved in the Duration folder</p>
<p>The report output button is not enabled.</p>	<p>15</p>	<p>Have you selected an indoor unit in the device selection tree?</p>	<p>Select one or more indoor units to output a report.</p>
<p>The tenant name is different in the tree view and the report view.</p>	<p>16</p>	<p>—</p>	<p>The tenant displayed in the tree view is the tenant name displayed on the system controller.</p> <p>The tenant name displayed in monthly, daily, and duration reports is the “Monthly report tenant name” for displaying reports.</p> <p>If you want to change the name, use the section change software. For details, refer to the instruction manual of the section change software.</p>

16 OSS License

This software contains licensed software or software whose copyright is owned by a third party according to the following.

JamesNK_Newtonsoft.Json

The MIT License (MIT)

Copyright (c) 2007 James Newton-King

Permission is hereby granted, free of charge, to any person obtaining a copy of this software and associated documentation files (the "Software"), to deal in the Software without restriction, including without limitation the rights to use, copy, modify, merge, publish, distribute, sublicense, and/or sell copies of the Software, and to permit persons to whom the Software is furnished to do so, subject to the following conditions:

The above copyright notice and this permission notice shall be included in all copies or substantial portions of the Software.

THE SOFTWARE IS PROVIDED "AS IS", WITHOUT WARRANTY OF ANY KIND, EXPRESS OR IMPLIED, INCLUDING BUT NOT LIMITED TO THE WARRANTIES OF MERCHANTABILITY, FITNESS FOR A PARTICULAR PURPOSE AND NONINFRINGEMENT. IN NO EVENT SHALL THE AUTHORS OR COPYRIGHT HOLDERS BE LIABLE FOR ANY CLAIM, DAMAGES OR OTHER LIABILITY, WHETHER IN AN ACTION OF CONTRACT, TORT OR OTHERWISE, ARISING FROM, OUT OF OR IN CONNECTION WITH THE SOFTWARE OR THE USE OR OTHER DEALINGS IN THE SOFTWARE.

Carrier Japan Corporation

336 TADEHARA, FUJI-SHI, SHIZUOKA-KEN 416-8521 JAPAN

©2024 Carrier. All Rights Reserved.

Revision record

Number	The contents of modification	Chapter	Date
First issue	—	—	Oct., 2023
Revision 1	Corporation name change	—	May, 2024