

FMU5X, FMC5X, FMU5Z, FMC5Z Multifamily Ceiling Mount Fan Coils for Puron Advance™ (R-454B) Refrigerant Sizes 18 To 36, 1-1/2 To 3 Nominal Tons



Product Data

NOTE: Read the entire instruction manual before starting the installation.

MULTIFAMILY CEILING MOUNT FAN COIL

- FMU5Z and FMC5Z 1-1/2, 2, 2-1/2, and 3 Tons
- FMU5X and FMC5X 1-1/2, 2, 2-1/2, and 3 Tons

All Models

- Horizontal application only
- Accessory field-installed electric heat kits available in 3, 5, 6, 7.5, or 10 kW
- 40VA, 208/230V-1-60 transformer
- All models use Puron Advance™, R-454B refrigerant and have a hard-shutoff TXV metering device
- Adjustable condensate drain pan

FM(C,U)5X, FM(C,U)5Z

- Horizontal return applications require field fabricated bottom cover
- Cabinets meet the requirement of 1.4% cabinet leakage rate when tested to ASHRAE Standard 193
- Cabinets insulated to prevent cabinet sweating
- Refrigerant lines and electrical connections can be run out the back or side of casing

Performance

- PSC motor on all FMU5X & FMC5X models
- ECM motor on all FMU5Z & FMC5Z models

Easy To Install Service

- A-coil design for maximum surface area
- Multiple electrical, refrigerant lineset and drain line entry for application flexibility
- Primary and secondary drain connections exit from the back or side of the cabinet
- Supports furred-down ceiling open return and ducted return applications
- Sweat connections for long term reliability
- Grooved aluminum tube / aluminum fin coils on FMU5X, FMC5X, FMC5Z, and FMU5Z models with “AL” in the 10th & 11th position

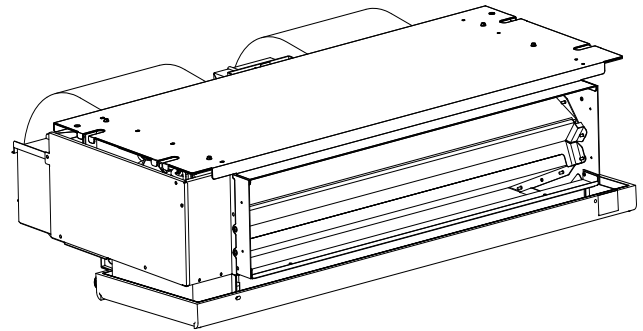

Fig. 1 – FMU5X & FMU5Z - Uncased Horizontal Fan Coil
(FMU5Z Model Shown)

A13303

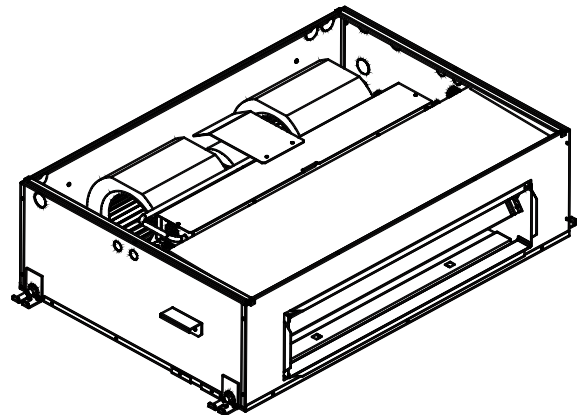

Fig. 2 – FMC5X & FMC5Z - Cased Horizontal Fan Coil
(Unit Pictured Upside Down)

A13304



ISO 9001
CERTIFIED SYSTEM



Use of the AHRI Certified™ Mark indicates a manufacturer's participation in the program. For verification of certification for individual products, go to www.ahridirectory.org.



WARRANTY

- Default 5-year parts limited warranty:
 - 10-year parts limited warranty with timely registration*.Equipment must be registered within 90 days of original installation, except in jurisdictions where warranty benefits cannot be conditioned on registration.
- * Applies to original purchaser/homeowner and not available to subsequent owners, except in jurisdictions where laws dictate otherwise.

See Warranty certificate for complete details and restrictions.

Model	Tons	Nominal BTU	CFM (L/s)	Dimensions H x W x D in. (mm)	Ship Wt. lbs. (kg)
UNCASED					
FMU5X1800AL	1-1/2	18,000	600(283)	10-1/4 x 26-3/8 x 37-1/4 (260 x 670 x 946)	75 (34)
FMU5X2400AL	2	24,000	800(378)		75 (34)
FMU5X3000AL	2-1/2	30,000	1000(472)	10-1/4x 26-3/8 x 49-1/4 (260 x 670 x 1251)	95 (43)
FMU5X3600AL	3	36,000	1200(566)		95 (43)
FMU5Z1800AL	1-1/2	18,000	600(283)	10-1/4 x 26-3/8 x 37-1/4 (260 x 670 x 946)	75 (34)
FMU5Z2400AL	2	24,000	800(378)		75 (34)
FMU5Z3000AL	2-1/2	30,000	1000(472)	10-1/4 x 26-3/8 x 49-1/4 (260 x 670 x 1251)	95 (43)
FMU5Z3600AL	3	36,000	1200(566)		95 (43)

CASED					
FMC5X1800AL	1-1/2	18,000	600(283)	11 x 28-3/8 x 43-3/8 (282 x 720 x 1101)	116 (52.5)
FMC5X2400AL	2	24,000	800(378)		116 (52.5)
FMC5X3000AL	2-1/2	30,000	1000(472)	11 x 28-3/8 x 55-3/8 (282 x 720 x 1406)	142 (64.5)
FMC5X3600AL	3	36,000	1200(566)		142 (64.5)
FMC5Z1800AL	1-1/2	18,000	600(283)	11 x 28-3/8 x 43-3/8 (282 x 720 x 1101)	116 (52.5)
FMC5Z2400AL	2	24,000	800(378)		116 (52.5)
FMC5Z3000AL	2-1/2	30,000	1000(472)	11 x 28-3/8 x 55-3/8 (282 x 720 x 1406)	142 (64.5)
FMC5Z3600AL	3	36,000	1200(566)		142 (64.5)

FAN COIL MODEL NUMBER NOMENCLATURE GUIDE								
	F	M	U	5	Z	2400	A	L
F = Fan Coil		TYPE		REFRIGERANT		REVISION		SALES CODE / FEATURES
M = Multi-Family		INSTALLATION TYPE		METERING DEVICE		NOMINAL CAPACITY		
U = Uncased C = Cased								
5 = R-454B Refrigerant								
X = R-454B TXV & PSC Motor Z = R-454B TXV & ECM Motor								
1800 = 18,000 BTUH = 1-1/2 tons 2400 = 24,000 BTUH = 2 tons 3000 = 30,000 BTUH = 2-1/2 tons 3600 = 36,000 BTUH = 3 tons								
A = Marketing Revision								
L = All Aluminum Coils								

ELECTRIC HEATER MODEL NUMBER IDENTIFICATION GUIDE				
	EHK	3	05	B
EHK = Electric Heater Kit		SALES CODE		NOMINAL HEAT VALUE
03 = 3 kW 05 = 5 kW 06 = 6 kW 08 = 7.5 kW 10 = 10 kW				
Engineering Code				

DIMENSIONS

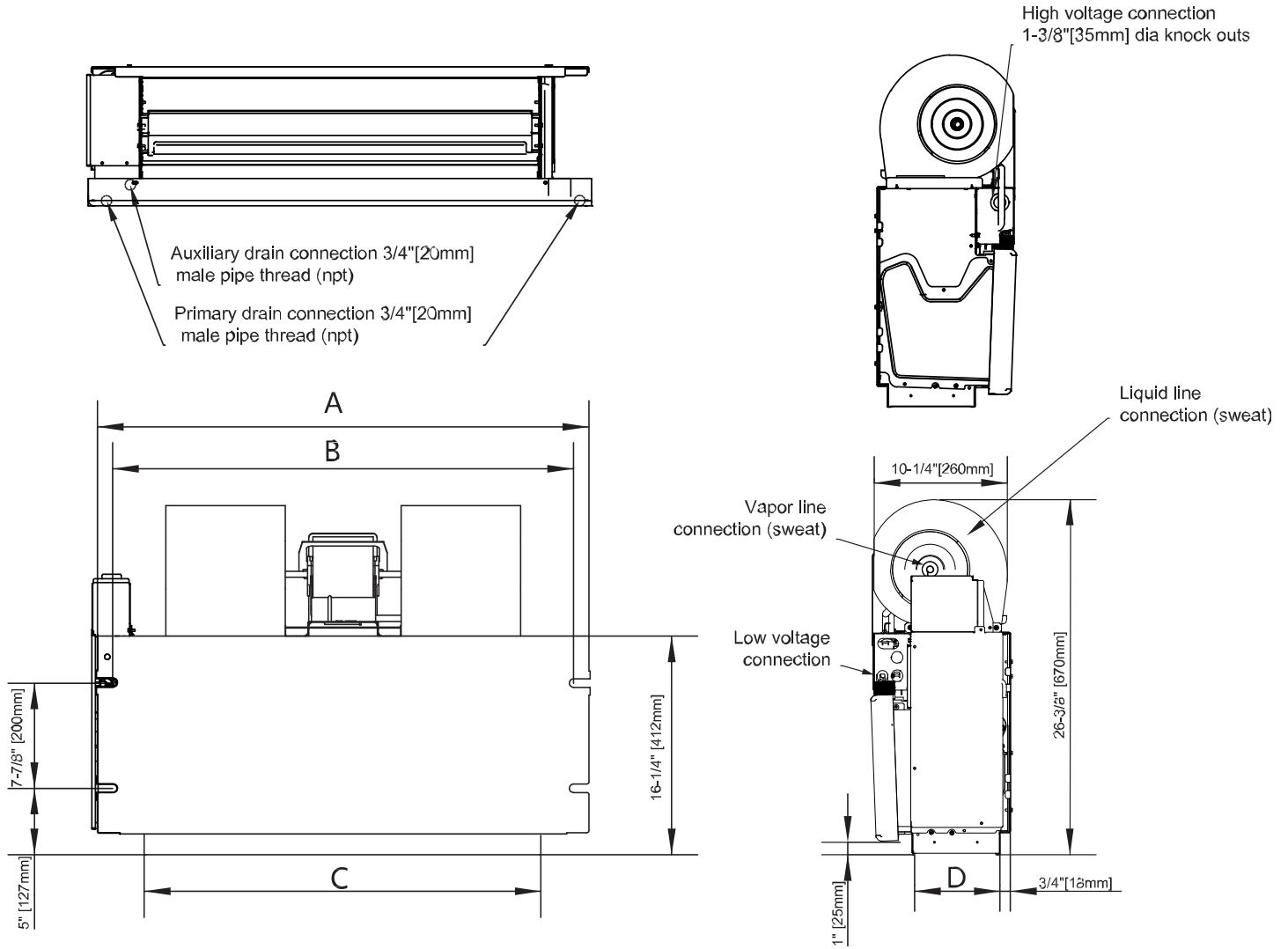

Fig. 3 – FMU5X & FMU5Z - Uncased Horizontal Fan Coil Dimensional Drawing (FMU5Z Model Shown)

A170307

Model Size	DIMENSIONS - INCHES (mm)				Unit Operating Weight lbs (kg)
	"A"	"B"	"C"	"D"	
18	37-1/4 (946)	34-11/16 (881)	30 (762)	6-1/2 (165)	75 (34)
24	37-1/4 (946)	34-11/16 (881)	30 (762)	6-1/2 (165)	75 (34)
30	49-1/4 (1251)	46-11/16 (1186)	42 (1067)	6-1/2 (165)	95 (43)
36	49-1/4 (1251)	46-11/16 (1186)	42 (1067)	6-1/2 (165)	95 (43)

DIMENSIONS

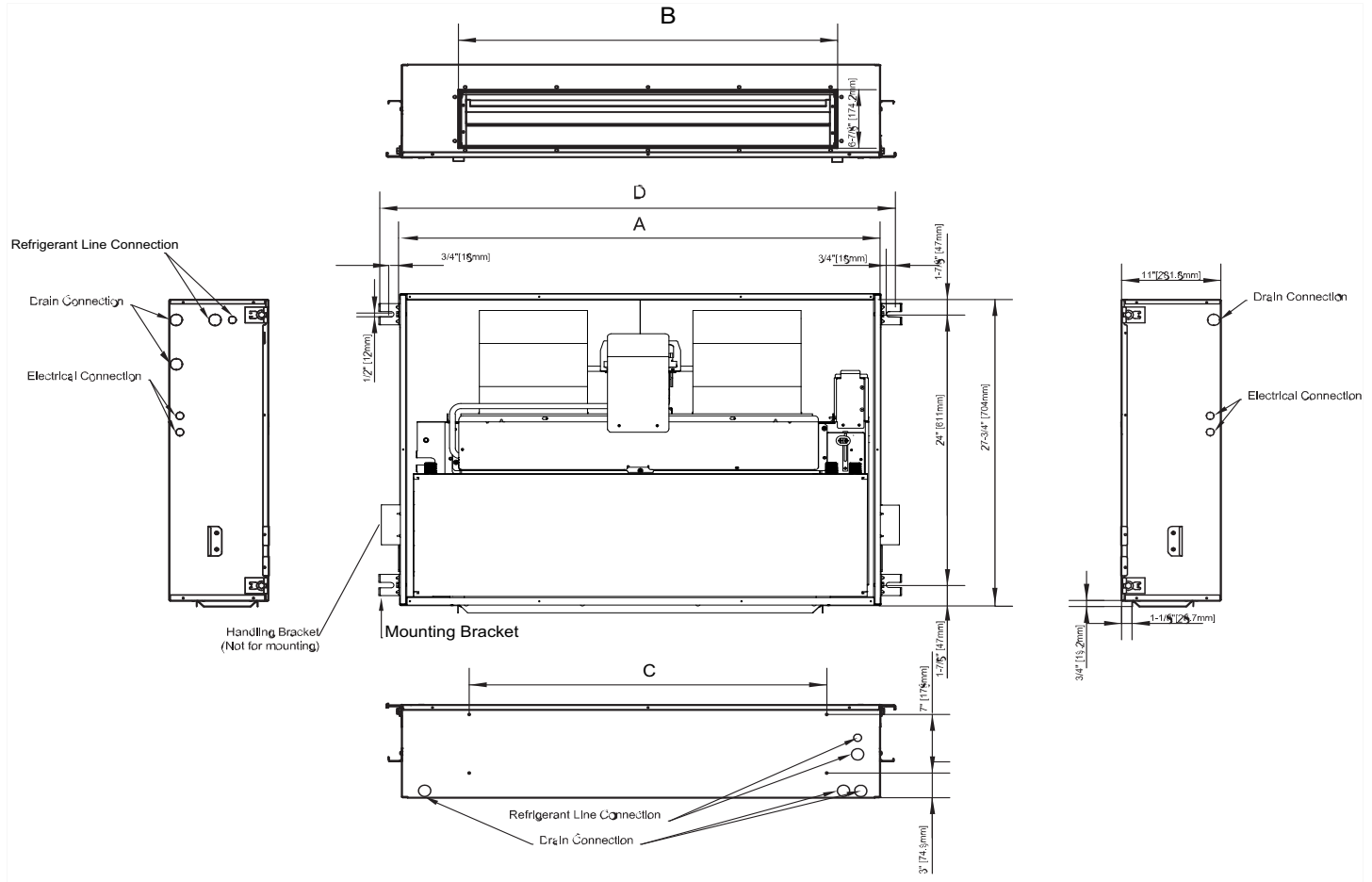

Fig. 4 – FMC5X & FMC5Z - Cased Horizontal Fan Coil Dimensional Drawing (FMC5Z Model Shown)

A170308

Model Size	DIMENSIONS - INCHES (mm)				Unit Operating Weight lbs (kg)
	A	B	C	D	
18	39-3/4 (1010)	30-3/8 (771)	28 (711)	43-3/8 (1101)	116 (52.5)
24	39-3/4 (1010)	30-3/8 (771)	28 (711)	43-3/8 (1101)	116 (52.5)
30	51-3/4 (1315)	42-3/8 (1076)	40 (1016)	55-3/8 (1406)	142 (64.5)
36	51-3/4 (1315)	42-3/8 (1076)	40 (1016)	55-3/8 (1406)	142 (64.5)

REQUIRED CLEARANCES - ALL MODELS - INCHES (mm)		
No Heaters	All Sides	0
	From Supply Duct	0
With Heaters	All Sides	0
	From Supply Duct	0

PHYSICAL DATA

	Unit Size			
FM(U,C)5Z	18	24	30	36
Nominal Cooling Capacity (BTUH)	18,000	24,000	30,000	36,000
R-454B COIL				
Puron Advance® (R-454B) - Refrigerant Metering Device	TXV	TXV	TXV	TXV
Coil Configuration	A-Coil			
BLOWER & MOTOR				
Air Discharge	Horizontal			
Blower Type	Dual Blower Direct Drive			
CFM (Nominal)	600	800	1000	1200
Motor Type	ECM	ECM	ECM	ECM
Motor HP	1/3	1/3	1/3	1/3
Rated RPM	1050	1050	1050	1050
Motor Speeds	5	5	5	5
FILTER				
Field Installed - in. (mm)	Qty. 2- 16x20x1 (406x508x25)	Qty. 2- 16x20x1 (406x508x25)	Qty. 2- 20x20x1 (508x508x25)	Qty. 2- 20x20x1 (508x508x25)
CONNECTIONS (Sweat)				
Suction - in. (mm)	3/4 in. (19 mm)			
Liquid - in. (mm)	3/8 in. (9.5 mm)			
Condensate (MPT) - in. (mm)	3/4 in. (19 mm)			
ELECTRICAL DATA				
Voltage	208/230	208/230	208/230	208/230
Hertz	60	60	60	60
Minimum Circuit Ampacity	3.3	3.3	3.3	3.3
Maximum Circuit Protector	15 (A)	15 (A)	15 (A)	15 (A)

	Unit Size			
FM(U,C)5X	18	24	30	36
Nominal Cooling Capacity (BTUH)	18,000	24,000	30,000	36,000
R-454B COIL				
Puron Advance® R-454B - Refrigerant Metering Device	TXV			
Coil Configuration	A-Coil			
BLOWER & MOTOR				
Air Discharge	Horizontal			
Blower Type	Dual Blower Direct Drive			
CFM (Nominal)	600	800	1000	1200
Motor Type	PSC	PSC	PSC	PSC
Motor HP	1/8	1/8	1/3	1/3
Rated RPM	1075	1075	1600	1600
Motor Speeds	3	3	3	3
FILTER				
Field Installed - in. (mm)	Qty. 2- 16x20x1 (406x508x25)	Qty. 2- 16x20x1 (406x508x25)	Qty. 2- 20x20x1 (508x508x25)	Qty. 2- 20x20x1 (508x508x25)
CONNECTIONS (Sweat)				
Suction - in. (mm)	3/4 in. (19 mm)			
Liquid - in. (mm)	3/8 in. (9.5 mm)			
Condensate (MPT) - in. (mm)	3/4 in. (19 mm)			
ELECTRICAL DATA				
Voltage	208/230	208/230	208/230	208/230
Hertz	60	60	60	60
Minimum Circuit Ampacity	1.3	1.3	2.3	2.3
Maximum Circuit Protector	15 (A)	15 (A)	15 (A)	15 (A)

PERFORMANCE DATA

AIRFLOW PERFORMANCE (Standard CFM)

Table 1 – Use for Selecting Heat Pump Speed of ECM Motor (Uncased, Back Return)

Model	Motor Speed	CFM Wet Coil without Filter or Electric Heat, Uncased, Back Return							
		External Static Pressure-Inches W.C.[kPa]							
		0[0]	0.1[.025]	0.2[.050]	0.3[.075]	0.38[.095]	0.4[.100]	0.5[.125]	0.6[.150]
18K	Tap (1)	778	708	648	585	527	505	443	387
	Tap (2) - Factory	904	843	789	735	685	670	621	549
	Tap (3)	1018	963	909	861	824	815	766	694
	Tap (4)	1122	1069	1021	978	945	933	888	692
	Tap (5)	1225	1178	1128	1087	1050	1031	901	707
24K	Tap (1)	778	708	648	585	527	505	443	387
	Tap (2)	904	843	789	735	692	681	621	549
	Tap (3) - Factory	1018	963	909	861	824	815	766	694
	Tap (4)	1122	1069	1021	978	945	933	888	692
	Tap (5)	1225	1178	1128	1087	1050	1031	901	707
30K	Tap (1)	887	786	675	578	506	491	412	338
	Tap (2)	1032	948	854	763	695	678	608	538
	Tap (3) - Factory	1167	1090	1012	936	868	846	771	713
	Tap (4)	1280	1216	1148	1084	1025	1009	930	785
	Tap (5)	1390	1328	1264	1202	1156	1145	1047	785
36K	Tap (1)	887	786	675	578	506	491	412	338
	Tap (2)	1032	948	854	763	695	678	608	538
	Tap (3)	1167	1090	1012	936	868	846	771	713
	Tap (4)	1280	1216	1148	1084	1025	1009	930	785
	Tap (5) - Factory	1390	1328	1264	1202	1156	1145	1047	785

■ - Shaded boxes represent airflow outside the required 300-450 cfm/ton.

1.Factory default taps are for performance ratings with single stage R-454B HP. For ACs, refer to the airflow details available on AHRI website and adjust tap accordingly.

Table 2 – Use for Selecting Heat Pump Speed of PSC Motor (Uncased, Bottom Return)

Model	Motor Speed	CFM Wet Coil without Filter or Electric Heat, Uncased, Bottom Return							
		External Static Pressure-Inches W.C.[kPa]							
		0[0]	0.05[.0125]	0.1[.025]	0.15[.0375]	0.2[.050]	0.25[.0625]	0.3[.075]	0.35[.0875]
18K	Low	720	696	667	639	600	545	466	386
	Med - Factory	990	945	897	845	788	727	656	531
	High	1041	991	940	882	823	763	687	574
24K	Low	720	696	667	639	600	545	466	386
	Med - Factory	990	945	897	845	788	727	656	531
	High	1041	991	940	882	823	763	687	574
Model	Motor Speed	CFM Wet Coil without Filter or Electric Heat, Uncased, Bottom Return							
		External Static Pressure-Inches W.C.[kPa]							
		0[0]	0.1[.025]	0.2[.050]	0.3[.075]	0.38[.095]	0.4[.100]	0.5[.125]	0.6[.150]
30K	Low - Factory	1177	1103	1024	934	858	843	742	626
	Med	1298	1218	1140	1058	972	957	859	737
	High	1418	1346	1272	1185	1116	1096	980	863
36K	Low	1177	1103	1024	934	858	843	742	626
	Med - Factory	1298	1218	1140	1058	972	957	859	737
	High	1418	1346	1272	1185	1116	1096	980	863

■ - Shaded boxes represent airflow outside the required 300-450 cfm/ton.

1.Airflow data is without filter or electric heat accessory. Heater adds 0.05-in. static.

2.Use wet coil data for determining cooling airflow.

3.Accessory louver panel adds 0.05-in. Static.

4.When electric heater is working only, 300CFM for each ton is sufficient except 30K work with 10kW heat??900SCFM?

5. Factory default taps are for performance ratings with single stage R-454B HP. For ACs, refer to the airflow details available on AHRI website and adjust tap accordingly.

PERFORMANCE DATA (cont.)

Table 3 – ECM - SELECTING HEAT PUMP SPEED OF ECM MOTOR (Cased, Back Return)

Model	Motor Speed	CFM Wet Coil without Filter or Electric Heat, Cased, Back Return							
		External Static Pressure-Inches W.C.[kPa]							
		[0]	0.1[.025]	0.15[.0375]	0.2[.050]	0.3[.075]	0.4[.100]	0.5[.125]	0.55[.1375]
18K	Tap (1)	755	691	631	551	512	497	429	399
	Tap (2) - Factory	876	821	766	710	658	639	594	574
	Tap (3)	980	925	874	829	794	784	720	699
	Tap (4)	1083	1034	988	947	912	904	860	703
	Tap (5)	1191	1149	1105	1067	1019	998	869	737
24K	Tap (1)	755	691	631	551	512	497	429	399
	Tap (2)	876	821	766	710	658	639	594	574
	Tap (3) - Factory	980	925	874	829	794	784	720	699
	Tap (4)	1083	1034	988	947	912	904	860	703
	Tap (5)	1191	1149	1105	1067	1019	998	869	737
30K	Tap (1)	866	769	655	564	492	473	396	360
	Tap (2)	1016	926	831	744	685	671	593	555
	Tap (3) - Factory	1144	1067	986	898	840	826	757	719
	Tap (4)	1272	1200	1128	1061	999	983	920	889
	Tap (5)	1372	1306	1243	1181	1127	1113	1027	930
36K	Tap (1)	866	769	655	564	492	473	396	360
	Tap (2)	1016	926	831	744	685	671	593	555
	Tap (3)	1144	1067	986	898	840	826	757	719
	Tap (4)	1272	1200	1128	1061	999	983	920	889
	Tap (5) - Factory	1372	1306	1243	1181	1127	1113	1027	930

■ - Shaded boxes represent airflow outside the required 300-450 CFM/ton.

1. Factory default taps are for performance ratings with single stage R-454B HP. For ACs, refer to the airflow details available on AHRI website and adjust tap accordingly.

Table 4 – ECM- SELECTING HEAT PUMP SPEED OF ECM MOTOR (Cased, Bottom Return)

Model	Motor Speed	CFM Wet Coil without Filter or Electric Heat, Cased, Bottom Return							
		External Static Pressure-Inches W.C.[kPa]							
		0[0]	0.1[.025]	0.2[.050]	0.3[.075]	0.38[.095]	0.4[.100]	0.5[.125]	0.55[.1375]
18K	Tap (1)	770	704	638	560	505	493	431	406
	Tap (2) - Factory	899	835	779	724	667	657	595	566
	Tap (3)	1015	964	910	861	821	810	748	694
	Tap (4)	1135	1085	1036	991	952	942	780	685
	Tap (5)	1228	1183	1137	1057	971	943	773	687
24K	Tap (1)	770	704	638	560	505	493	431	406
	Tap (2)	899	835	779	724	667	657	595	566
	Tap (3) - Factory	1015	964	910	861	821	810	748	694
	Tap (4)	1135	1085	1036	991	952	942	780	685
	Tap (5)	1228	1183	1137	1057	971	943	773	687
30K	Tap (1)	904	775	678	586	516	498	416	379
	Tap (2)	1052	950	834	755	693	677	595	563
	Tap (3) - Factory	1186	1098	992	908	853	839	771	738
	Tap (4)	1323	1245	1145	1063	1003	988	900	794
	Tap (5)	1432	1361	1274	1183	1091	1068	903	799
36K	Tap (1)	904	775	678	586	516	498	416	379
	Tap (2)	1052	950	834	755	693	677	595	563
	Tap (3)	1186	1098	992	908	853	839	771	738
	Tap (4)	1323	1245	1145	1063	1003	988	900	794
	Tap (5) - Factory	1432	1361	1274	1183	1091	1068	903	799

■ - Shaded boxes represent airflow outside the required 300-450 CFM/ton.

- Airflow data is without filter or electric heat accessory. Heater adds 0.05 -in. static.
- Use wet coil data for determining cooling airflow
- Accessory louver panel adds 0.05 -in. Static.
- When electric heater is working only, 300CFM for each ton is sufficient except 30K work with 10KW heat (900SCFM)
- Factory default taps are for performance ratings with single stage R-454B HP. For ACs, refer to the airflow details available on AHRI website and adjust tap accordingly.

PERFORMANCE DATA (cont.)

Table 5 – Use for Selecting Heat Pump Speed of PSC Motor (Cased, Back Return)

Model	Motor Speed	CFM Wet Coil without Filter or Electric Heat, Cased, Back Return							
		External Static Pressure-Inches W.C.[kPa]							
		0[0]	0.05[.0125]	0.1[.025]	0.15[.0375]	0.2[.050]	0.25[.0625]	0.3[.075]	0.35[.0875]
18	Low	698	674	646	620	582	527	457	361
	Med - Factory	971	921	874	827	776	718	661	519
	High	1034	985	934	882	820	759	683	565
24	Low	698	674	646	620	582	527	457	361
	Med - Factory	971	921	874	827	776	718	661	519
	High	1034	985	934	882	820	759	683	565
Model	Motor Speed	CFM Wet Coil without Filter or Electric Heat, Cased, Back Return							
		External Static Pressure-Inches W.C.[kPa]							
		0[0]	0.1[.025]	0.2[.050]	0.3[.075]	0.38[.095]	0.4[.100]	0.5[.125]	0.6[.150]
30	Low - Factory	1193	1094	1005	932	840	828	734	627
	Med	1301	1209	1109	1033	972	929	840	726
	High	1419	1332	1219	1134	1070	1053	928	823
36	Low	1193	1094	1005	932	840	828	734	627
	Med - Factory	1301	1209	1109	1033	972	929	840	726
	High	1419	1332	1219	1134	1070	1053	928	823

■ - Shaded boxes represent airflow outside the required 300-450 CFM/ton.
 1. Factory default taps are for performance ratings with single stage R-454B HP. For ACs, refer to the airflow details available on AHRI website and adjust tap accordingly.

Table 6 – Use for Selecting Heat Pump Speed of PSC Motor (Cased, Bottom Return)

Model	Motor Speed	CFM Wet Coil without Filter or Electric Heat, Cased, Bottom Return							
		External Static Pressure-Inches W.C.[kPa]							
		0[0]	0.05[.0125]	0.1[.025]	0.15[.0375]	0.2[.050]	0.25[.0625]	0.3[.075]	0.35[.0875]
18	Low	736	706	673	634	579	526	430	363
	Med - Factory	959	914	860	802	738	658	587	467
	High	997	956	907	846	775	700	614	512
24	Low	736	706	673	634	579	526	430	363
	Med - Factory	959	914	860	802	738	658	587	467
	High	997	956	907	846	775	700	614	512
Model	Motor Speed	CFM Wet Coil without Filter or Electric Heat, Cased, Bottom Return							
		External Static Pressure-Inches W.C.[kPa]							
		0[0]	0.1[.025]	0.2[.050]	0.3[.075]	0.38[.095]	0.4[.100]	0.5[.125]	0.6[.150]
30	Low - Factory	1168	1092	1009	928	860	845	760	616
	Med	1272	1199	1117	1039	969	953	870	764
	High	1396	1322	1251	1162	1083	1067	973	872
36	Low	1168	1092	1009	928	860	845	760	616
	Med - Factory	1272	1199	1117	1039	969	953	870	764
	High	1396	1322	1251	1162	1083	1067	973	872

■ - Shaded boxes represent airflow outside the required 300-450 CFM/ton.
 1. Airflow data is without filter or electric heat accessory. Heater adds 0.05 -in. static.
 2. Use wet coil data for determining cooling airflow
 3. Accessory louver panel adds 0.05 -in. Static.
 4. When electric heater is working only, 300CFM for each ton is sufficient except 30K work with 10KW heat (≈900SCFM)
 5. Factory default taps are for performance ratings with single stage R-454B HP. For ACs, refer to the airflow details available on AHRI website and adjust tap accordingly.

Table 7 – Required CFM Range

Size	CFM	
	Min	Max
18	450	675
24	600	900
30	750	1125
36	900	1350

PERFORMANCE DATA (cont.)

Table 8 – GROSS COOLING CAPACITIES (MBH)

INDOOR COIL AIR		SATURATED TEMPERATURE LEAVING EVAPORATOR (°F)														
		35			40			45			50			55		
CFM	EWB	TC	SHC	BF	TC	SHC	BF	TC	SHC	BF	TC	SHC	BF	TC	SHC	BF
FM(C,U)5(X,Z)1800AL																
525	72	49.16	22.32	0.04	42.51	19.02	0.04	35.87	15.93	0.05	29.23	12.94	0.05	22.59	10.58	0.09
	67	42.51	24.17	0.05	35.87	20.67	0.05	29.23	17.37	0.06	22.59	14.49	0.09	15.94	11.81	0.11
	62	35.87	25.51	0.06	29.23	21.80	0.06	22.59	18.40	0.07	15.94	15.52	0.11	9.30	9.30	0.47
600	72	55.50	25.15	0.04	48.00	21.39	0.05	40.50	17.97	0.05	33.00	14.79	0.06	25.50	11.97	0.09
	67	48.00	27.39	0.05	40.50	23.39	0.05	33.00	19.74	0.06	25.50	16.44	0.09	18.00	13.38	0.11
	62	40.50	28.80	0.06	33.00	24.68	0.06	25.50	20.91	0.07	18.00	17.50	0.11	10.50	10.50	0.48
675	72	61.84	28.03	0.04	53.48	23.79	0.05	45.12	20.09	0.06	36.77	16.51	0.06	28.41	13.33	0.08
	67	53.48	30.55	0.05	45.12	26.05	0.05	36.77	22.07	0.07	28.41	18.36	0.09	20.05	14.92	0.11
	62	45.12	32.27	0.06	36.77	27.63	0.07	28.41	23.40	0.07	20.05	19.69	0.12	11.70	11.70	0.48
FM(C,U)5(X,Z)2400AL																
INDOOR COIL AIR		SATURATED TEMPERATURE LEAVING EVAPORATOR (°F)														
		35			40			45			50			55		
CFM	EWB	TC	SHC	BF	TC	SHC	BF	TC	SHC	BF	TC	SHC	BF	TC	SHC	BF
FM(C,U)5(X,Z)2400AL																
700	72	63.95	28.93	0.04	55.31	24.68	0.05	46.67	20.83	0.06	38.02	17.12	0.06	29.38	13.83	0.08
	67	55.31	31.54	0.05	46.67	27.01	0.05	38.02	22.75	0.06	29.38	19.04	0.09	20.74	15.47	0.11
	62	46.67	33.33	0.06	38.02	28.52	0.06	29.38	24.26	0.08	20.74	20.28	0.11	12.10	12.10	0.49
800	72	72.40	32.75	0.04	62.62	27.89	0.05	52.83	23.33	0.06	43.05	18.63	0.06	33.27	15.64	0.08
	67	62.62	35.89	0.05	52.83	30.55	0.05	43.05	25.85	0.06	33.27	21.61	0.09	23.48	17.68	0.11
	62	52.83	37.78	0.06	43.05	32.44	0.06	33.27	27.57	0.08	23.48	23.18	0.11	13.70	13.70	0.49
900	72	80.86	36.49	0.04	69.93	31.20	0.05	59.00	26.07	0.06	48.08	21.66	0.06	37.15	17.42	0.08
	67	69.93	39.85	0.05	59.00	34.20	0.05	48.08	28.90	0.05	37.15	24.13	0.09	26.22	19.72	0.11
	62	59.00	42.32	0.06	48.08	36.32	0.06	37.15	30.84	0.08	26.22	25.90	0.11	15.30	15.30	0.49
FM(C,U)5(X,Z)3000AL																
INDOOR COIL AIR		SATURATED TEMPERATURE LEAVING EVAPORATOR (°F)														
		35			40			45			50			55		
CFM	EWB	TC	SHC	BF	TC	SHC	BF	TC	SHC	BF	TC	SHC	BF	TC	SHC	BF
FM(C,U)5(X,Z)3000AL																
875	72	66.61	29.64	0.05	57.61	25.52	0.06	48.61	21.75	0.06	39.61	18.31	0.08	30.61	16.60	0.08
	67	57.61	33.42	0.05	48.61	28.96	0.06	39.61	24.84	0.07	30.61	21.23	0.08	21.60	17.80	0.13
	62	48.61	36.34	0.07	39.61	31.87	0.07	30.61	27.58	0.08	21.60	21.60	0.25	12.60	12.60	0.57
1000	72	74.13	32.90	0.05	64.12	28.38	0.06	54.10	24.46	0.06	44.08	20.54	0.08	34.06	17.00	0.09
	67	64.12	37.21	0.05	54.10	32.50	0.07	44.08	27.99	0.08	34.06	24.07	0.10	24.04	20.14	0.14
	62	54.10	40.74	0.07	44.08	35.64	0.07	34.06	31.13	0.08	24.04	24.04	0.27	14.03	14.03	0.59
1125	72	81.65	36.35	0.05	70.62	31.27	0.06	59.58	26.85	0.06	48.55	22.66	0.08	37.52	18.91	0.09
	67	70.62	41.20	0.05	59.58	35.90	0.07	48.55	31.05	0.08	37.52	26.63	0.09	26.48	22.44	0.14
	62	59.58	45.18	0.07	48.55	39.66	0.08	37.52	34.58	0.08	26.48	26.48	0.29	15.45	15.45	0.60
M(C,U)5(X,Z)3600AL																
INDOOR COIL AIR		SATURATED TEMPERATURE LEAVING EVAPORATOR (°F)														
		35			40			45			50			55		
CFM	EWB	TC	SHC	BF	TC	SHC	BF	TC	SHC	BF	TC	SHC	BF	TC	SHC	BF
M(C,U)5(X,Z)3600AL																
1050	72	77.14	34.34	0.05	66.72	29.60	0.06	56.29	25.48	0.07	45.87	21.36	0.08	35.44	17.65	0.08
	67	66.72	38.87	0.05	56.29	33.92	0.06	45.87	29.18	0.08	35.44	25.06	0.09	25.02	20.94	0.13
	62	56.29	42.58	0.07	45.87	37.22	0.07	35.44	31.24	0.08	25.02	13.12	0.26	14.59	2.69	0.60
1200	72	86.16	38.30	0.05	74.52	33.12	0.06	62.88	28.41	0.07	51.23	23.94	0.08	39.59	19.93	0.09
	67	74.52	43.48	0.05	62.88	38.06	0.06	51.23	32.88	0.08	39.59	28.17	0.09	27.95	23.70	0.13
	62	62.88	47.95	0.07	51.23	42.07	0.08	39.59	36.89	0.09	27.95	29.99	0.29	16.30	18.34	0.60
1350	72	95.19	42.29	0.05	82.33	36.73	0.07	69.46	31.70	0.07	56.60	26.66	0.09	43.74	21.90	0.09
	67	82.33	48.12	0.06	69.46	42.29	0.06	56.60	36.46	0.08	43.74	31.43	0.09	30.87	26.66	0.14
	62	69.46	53.15	0.07	56.60	46.79	0.08	43.74	40.97	0.08	30.87	50.07	0.29	18.01	37.21	0.60

PERFORMANCE DATA (cont.)

Table 9 – SENSIBLE CAPACITY (SHC) CORRECTION FACTOR

BYPASS FACTOR	ENTERING AIR DRY-BULB TEMPERATURE (°F)					
	79	78	77	76	75	Under 75
	81	82	83	84	85	Over 85
	ENTERING AIR DRY-BULB TEMPERATURE (°C)					
	26	25	25	24	24	Under 75
	27	28	28	29	29	Over 85
Correction Factor						
0.10	.098	1.96	2.94	3.92	4.91	Use formula shown below
0.20	0.87	1.74	2.62	3.49	4.36	
0.30	0.76	1.53	2.29	3.05	3.82	

Interpolation is permissible.. Correction Factor = 1.09 x (1 - BF) x (db - 80).

NOTES:

1. Contact manufacturer for cooling capacities at conditions other than shown in table.
2. Formulas:
 Leaving db = entering db - $\frac{\text{sensible heat cap.}}{1.09 \times \text{CFM}}$
 Leaving wb = wb corresponding to enthalpy of air leaving coil (h_{1wb})
 $h_{1wb} = h_{ewb} - \frac{\text{total capacity (Btuh)}}{4.5 \times \text{CFM}}$
 where h_{ewb} = enthalpy of air entering coil. Direct interpolation is permissible.
 Do not extrapolate.
3. SHC is based on 80°F (27°C) db temperature of air entering coil.
 Below 80°F (27°C) db, subtract (Correction Factor x CFM) from SHC.
 Above 80°F (27°C) db, add (Correction Factor x CFM) to SHC.
4. Bypass Factor = 0 indicates no psychometric solution.
 Use bypass factor of next lower EWB for approximation.

Table 10 – ESTIMATED SOUND POWER LEVEL (dBA)

PSC ESTIMATED SOUND PRESSURE LEVEL									
UNIT SIZE		18K	24K	30K	36K				
Indoor Sound Pressure Level	dBA High	54	54	62.5	62.5				
Estimated Sound Power	W High	66	66	74.5	74.5				
SOUND PRESSURE DATA									
UNIT SIZE	CONDITIONS		OCTAVE BAND CENTER FREQUENCY						
	CFM	Ext Static Pressure	63	125	250	500	1000	2000	4000
18	600	0.18	49.1	51.8	45.1	47.1	48.8	45.7	42.7
24	800	0.18	49.1	51.8	45.1	47.1	48.8	45.7	42.7
30	1000	0.24	66.3	57.3	60.0	61.8	55.2	52.7	49.6
36	1200	0.24	66.3	57.3	60.0	61.8	55.2	52.7	49.6

ECM ESTIMATED SOUND PRESSURE LEVEL									
UNIT SIZE		18K	24K	30K	36K				
Indoor Sound Pressure Level	dBA High	54	54	62.5	62.5				
Estimated Sound Power	W High	66	66	74.5	74.5				
SOUND PRESSURE DATA									
UNIT SIZE	CONDITIONS		OCTAVE BAND CENTER FREQUENCY						
	CFM	Ext Static Pressure	63	125	250	500	1000	2000	4000
18	600	0.18	49.1	51.8	45.1	47.1	48.8	45.7	42.7
24	800	0.18	49.1	51.8	45.1	47.1	48.8	45.7	42.7
30	1000	0.24	66.3	57.3	60.0	61.8	55.2	52.7	49.6
36	1200	0.24	66.3	57.3	60.0	61.8	55.2	52.7	49.6

* Estimated sound power levels have been derived using the method described in the 1987 ASHRAE HVAC Systems & Applications Handbook, Chapter 52, p. 52.7.

PERFORMANCE DATA (cont.)

Table 11 – OPTIONAL FIELD-INSTALLED ELECTRIC HEAT PACKAGES

HEATER PART NUMBER WITH TDR	SIZES USED WITH	NOMINAL kw @ 240V	HEATER VOLTS-PHASE (60 Hz)	HEATER CAPACITY (MBH)		MIN. CIRCUIT AMPACITY		MAX. FUSE OR BREAKER (HACR) AMPACITY		APPROX. SHIPWGT. LBS. (kg)
				208	240	208	240	208	240	
EHK303B	All	3	208/240-1	7.7	10.2	15.8	17.9	20	20	10 (4.5)
EHK305B	All	5	208/240-1	12.8	17.1	24.9	28.3	30	30	10 (4.5)
EHK306B	All	6	208/240-1	15.4	20.5	29.4	33.5	35	35	10 (4.5)
EHK308B	All	7.5	208/240-1	19.3	25.7	36.1	41.4	50	50	10 (4.5)
EHK310B	All	10	208/240-1	24.7	32.8	45.5	52.3	60	60	10 (4.5)

OTHER ACCESSORIES

KIT NUMBER	DESCRIPTION	USED ON SIZES
KFAGP010ICOV	Solid Access Panel, Small	18, 24
KFAGP020ICOV	Solid Access Panel, Large	30, 36
KFAGP0101LGL	Louvered Access Panel with Filter Rack	18, 24
KFAGP0201LGL	Louvered Access Panel with Filter Rack	30, 36
AFALFGSML01A	Louvered Access Panel with Filter Rack, Small (Title 24 compliant)	18, 24
AFALFGLRG01A	Louvered Access Panel with Filter Rack, Large (Title 24 compliant)	30, 36
KFAET0150ETK	PVC Condensate Trap Kit (50 pack)	18, 24, 30, 36

Training

My Learning Center is your central location for professional residential HVAC training resources that help strengthen careers and businesses. We believe in providing high quality learning experiences both on line and in the classroom.

Access My Learning Center with your HVAC Partners credentials at www.mlctraining.com. Please contact us at mylearning@carrier.com with questions.