



# MicroMetl

Sensors  
Product Data Sheet



# MicroMetl

## Table of Contents

---

Topic	Page Number
CO2 Sensor Manufacturer's Guide	1

# C7232A,B Sensor and Controller

## CARBON DIOXIDE SENSOR

### PRODUCT DATA



## FEATURES

- Used for CO<sub>2</sub> based ventilation control.
- Models available with LCD that provides sensor readings and status information.
- Non-Dispersion-Infrared (NDIR) technology used to measure carbon dioxide gas.
- Device provides voltage or current output based on CO<sub>2</sub> levels.
- Models available with SPST relay output.
- Automatic Background Calibration (ABC) algorithm based on long-term evaluation reduces required typical zero-drift check maintenance.

## APPLICATION

The C7232 Sensor and Controller is a stand-alone carbon dioxide (CO<sub>2</sub>) sensor for use in determining ventilation necessity with HVAC controllers. The C7232 measures the CO<sub>2</sub> concentration in the ventilated space or duct. The C7232 is used in ventilation and air conditioning systems to control the amount of fresh outdoor air supplied to maintain acceptable levels of CO<sub>2</sub> in the space.

### Contents

Application .....	1
Features .....	1
Specifications .....	2
Installation .....	3
Ordering Information .....	2
Wiring .....	4
Checkout .....	5
Appendix .....	6



# SPECIFICATIONS

**Models:** C7232 Sensor and Controller. A stand-alone carbon dioxide (CO<sub>2</sub>) sensor with two jumper-adjustable outputs (one analog and one SPST relay).

C7232A: Wall mount model.  
C7232B: Duct mount model.

**NOTE:** Models are available with or without a 4-digit LCD that indicates the current CO<sub>2</sub> concentration.

**Dimensions:**

C7232A: See Fig. 1.  
C7232B: See Fig. 2.

**Sensor Performance Ratings:**

Response Time: 1 min.  
Carbon Dioxide Sensor:  
Operation: Non-dispersive infrared (NDIR).  
Sampling: Diffusion.  
Range: 0 to 2000 ppm  
Accuracy: ± (30 ppm +2% of reading)\*.

\* This product complies with CA Title 24, Part 6, CEC Standard for Residential and Non-Residential Buildings—2016, when installed according to instructions.

**Electrical Ratings:**

Power Supply: 24 Vac/dc ±20%, 50/60 Hz (Class 2).  
Maximum Power Consumption: 3W.  
Peak Current (at 20 ms): 600 mA.  
Relay:  
Configuration: Shipped N.O.  
Contact Rating: 1A at 50 Vac/24 Vdc.  
Minimum Permissible Load: 1 mA at 5 Vdc.  
Linear Analog Output:  
Voltage: 0/2-10 Vdc (resistive load greater than 5000 ohms).  
Current: 0/4-20 mA (resistive load less than 500 ohms).

**Outputs (Jumper Adjustable, see Table 2):**

Analog: 0-10 Vdc (Default: 2-10 Vdc, 500 to 1500 ppm).  
Relay: Normally Open SPST (Default: Close at 800 ppm).

**Ambient Ratings:**

Temperature:  
Operating: +32°F to +122°F (0°C to +50°C).  
Storage: -4°F to +158°F (-20°C to +70°C).  
Relative Humidity (non-condensing): 0 to 95 percent.

**CO<sub>2</sub> Pressure Dependence:** 1.4% change in reading per 1 kPa deviation from 100 kPa.

**Wiring Connections:**

C7232A: 20-gauge cable with six 8 in. leadwires.  
C7232B: 20-gauge cable with six 6 in. leadwires.

**Mounting:**

C7232A: Vertical surface with standard single-gang junction box.  
C7232B: Sheet metal duct with a sampling tube.

**Automatic Background Calibration (ABC) default: On.**

**Calibration:** This product is factory calibrated. No field calibration is necessary for the life of this product.

**Approvals:**

CE  
Underwriters Laboratories Inc. Listed, File No. E4436 cUL  
C7232B: Flammability Rating, UL94-5V  
C7232A: NEMA1  
C7232B: NEMA3

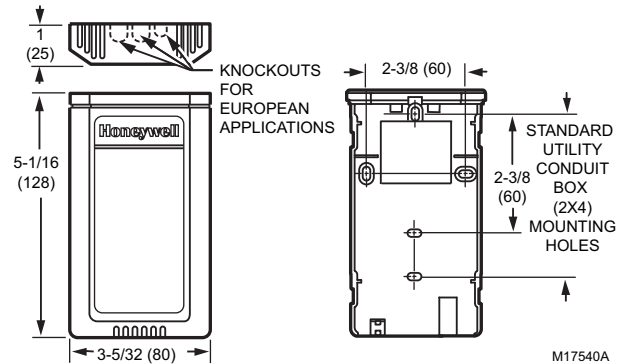

**Fig. 1. C7232A dimensions in inches (mm).**

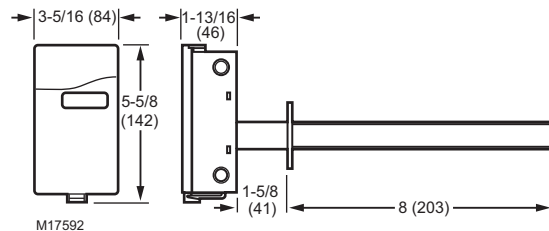

**Fig. 2. C7232B dimensions in inches (mm).**

# ORDERING INFORMATION

When purchasing replacement and modernization products from your TRADELINE® wholesaler or distributor, refer to the TRADELINE® Catalog or price sheets for complete ordering number. If you have additional questions, need further information, or would like to comment on our products or services, please write or phone:

1. Your local Honeywell Environmental and Combustion Controls Sales Office (check white pages of your phone directory).
2. Honeywell Customer Care  
1985 Douglas Drive North  
Golden Valley, Minnesota 55422-4386
3. <http://customer.honeywell.com> or <http://customer.honeywell.ca>

International Sales and Service Offices in all principal cities of the world. Manufacturing in Belgium, Canada, China, Czech Republic, Germany, Hungary, Italy, Mexico, Netherlands, United Kingdom, and United States.

# INSTALLATION

## When Installing this Product...

1. Read these instructions carefully. Failure to follow them could damage the product or cause a hazardous condition.
2. Check the ratings given in the instructions and on the product to make sure the product is suitable for your application.
3. Installer must be a trained, experienced service technician.
4. After installation is complete, check out product operation as provided in these instructions.

### IMPORTANT

All wiring must agree with applicable codes, ordinances and regulations.



## CAUTION

### Health Hazard.

### Improper use can create dangerous situations.

Use in application for sensing carbon dioxide only. For life-safety applications, this device can function only as a secondary or lesser device.



## CAUTION

### Electrical Shock or Equipment Damage Hazard. Can shock individuals or short equipment circuitry.

Disconnect power supply before installation.



## CAUTION

### Equipment Damage Hazard. Electrostatic discharge can short equipment circuitry.

Ensure that you are properly grounded before handling the unit.

## C7232A Cover Removal/Replacement

### C7232A Cover Removal (see Fig. 3)

1. Remove button head socket cap screw and set it aside.
2. Insert the head of a small screwdriver into the slot at the center and near the top of the cover.
3. Gently pull the handle down toward the bottom of the device until a small gap between the subbase and the cover appears.
4. Remove the screwdriver and pull the cover straight down until it meets a stop.
5. Pull the cover straight off the subbase.

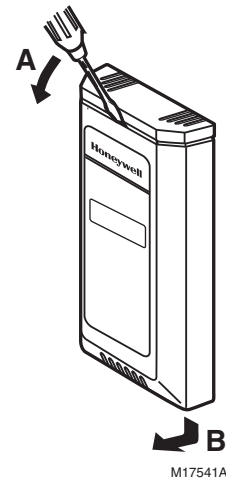

Fig. 3. C7232A cover removal.

## C7232A Cover Replacement

1. Feed the wires through the opening in the subbase.
2. Place the cover, with a small gap at the top, flat on top of the subbase.
3. When the cover rests flat on the subbase, slide it straight up until it latches in place.

## Location and Mounting

C7232 Sensors mount directly on the wall, sheet metal duct, or a panel. When planning the installation, allow enough clearance for maintenance and service. Mount the sensor in a well-ventilated area.

### NOTES:

Do not install the sensor where it can be affected by:

- drafts or dead spots behind doors and in corners.
- air from ducts.

Sensor must be mounted in a location which sees at least one 4-hour unoccupied period per week so that the CO<sub>2</sub> level drops to outdoor levels. Automatic Background Calibration will not work properly in locations without four hours of unoccupied time per week, or where there are sources of CO<sub>2</sub> other than people (breweries, mushroom farms, etc).

### IMPORTANT

This sensor is not for use in highly corrosive environments.

## Wall Mounting

The C7232 Wall Mount models can be mounted using two or four screws:

1. Remove C7232 cover.
2. Mount the subbase to the wall using washers and two or four screws (not supplied) appropriate for the wall material.

NOTE: When mounting on a junction box, see Fig. 4.

3. Replace the cover.

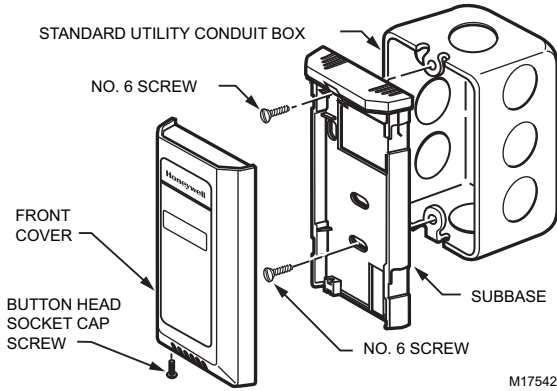

Fig. 4. Junction box mounting (C7232A).

### Duct Mounting (see Fig. 5)

1. Place gasket on aspiration tube.

**IMPORTANT**

Ensure largest tab at tube control end is at the top.

2. Insert tube into duct; attach using screws and washers.

**IMPORTANT**

Leakage into the duct or the C7232 box cover from the room will skew the sensor readings. Ensure the box cover and duct seal completely.

3. Place O-ring on tube end; mount the control to the tube.

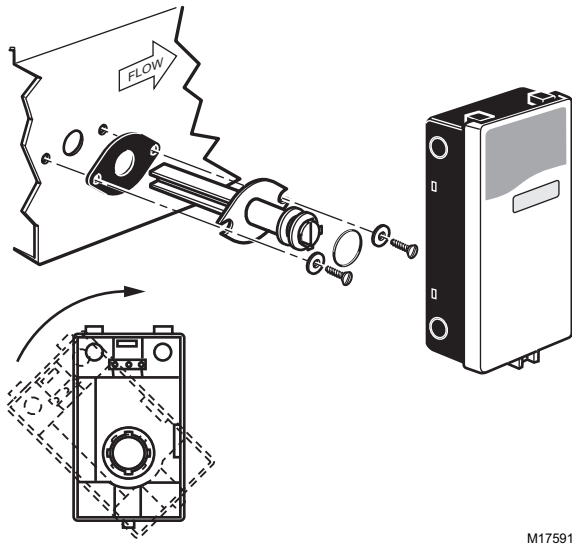

Fig. 5. Duct mounting (C7232B).

## WIRING

The factory ships the device with the output default settings shown in Tables 2 and 3. Set the jumpers and wire the device (see Table 1 and Fig. 6).



### CAUTION

**Electrical Shock or Equipment Damage Hazard. Can shock individuals or short equipment circuitry.**

Disconnect power supply before installation.



### CAUTION

**Equipment Damage Hazard. Electrostatic Discharge Can Short Equipment Circuitry.**

Ensure that you are properly grounded before handling the unit.

**IMPORTANT**

1. All low voltage connections to this device must be 24 Vac Class 2.
2. All wiring must comply with applicable local codes, ordinances and regulations.

Table 1. C7232 Wiring Connections (see Fig. 6).

Wire Color	Designation	Function
Red	G+	24 V Hot
Black	G0	24 V Common
Yellow	OUT1	Analog Output Signal
Brown	M	Analog Output Common
Orange	NO	Relay Output Normally Open
Green	COM	Relay Output Common

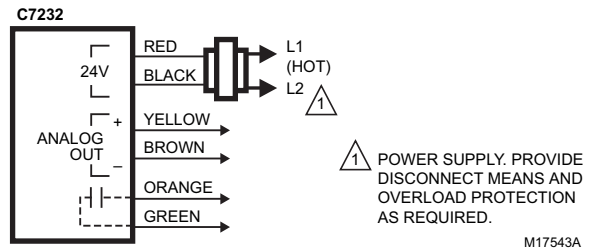

Fig. 6. Wiring the C7232.

## Input Signal

The C7232 Sensors have an adjustable range. These ranges are determined by the SW1 and SW2 jumper settings (see Table 2).

**Table 2. CO<sub>2</sub> Range Jumper Settings**

SW1	SW2	AN (ppm)	Relay <sup>a</sup> (ppm)
On	On	0 to 1000	1000
On	Off	0 to 2000	1200
Off <sup>b</sup>	On <sup>b</sup>	500 to 1500	800
Off	Off	500 to 2000	1200

<sup>a</sup> When the level reaches this value, the contacts close; when the level drops 100 ppm below this value, the contacts open.

<sup>b</sup> Setting when shipped from the factory.

## Output Signal

The output signal can be adjusted for 0/2-10 Vdc or 0/4-20 mA (see Table 3).

**Table 3. Output Signal Jumper Settings**

AN	OUT	
	0-100%	20-100%
Voltage	0-10Vdc	2-10Vdc
Current	0-20 mA	4-20 mA

## Example

For a CO<sub>2</sub> setting of 0-2000 ppm and a voltage output of 0-10 Vdc, the output would be as shown in Table 4 (arbitrary points along the analog curve).

**Table 4. 0-10 Vdc Output Example.**

CO <sub>2</sub> Level (ppm)	0	200	400	600	800	1000	1200	1400	1600	1800	2000
Voltage Output (Vdc)	0	1	2	3	4	5	6	7	8	9	10

For a CO<sub>2</sub> setting of 0-2000 ppm and a voltage output of 2-10 Vdc, the output would be as shown in Table 5 (arbitrary points along the analog curve).

**Table 5. 2-10 Vdc Output Example.**

CO <sub>2</sub> Level (ppm)	0	250	500	750	1000	1250	1500	1750	2000
Voltage Output (Vdc)	2	3	4	5	6	7	8	9	10

## CHECKOUT

Perform a quick test of the unit with the unit powered:

1. Stand close to the unit and breathe air into the sensor.
2. Check the CO<sub>2</sub> level registered by the controller to ensure a strong rise.
3. When connected to a damper in a ventilation system, the controller typically signals an increase in air flow.

### NOTES:

- Jumper sensors are shown on the sticker on the inside of the cover.
- Use needle nose pliers to carefully reposition jumpers.
- The CO<sub>2</sub> settings and the output signal settings are independent of each other. 0-100% and 20-100% are simply markings for the OUT jumper settings on the sensor (to differentiate between the two voltage and the two current ranges) and do not refer to or alter the ppm range chosen.

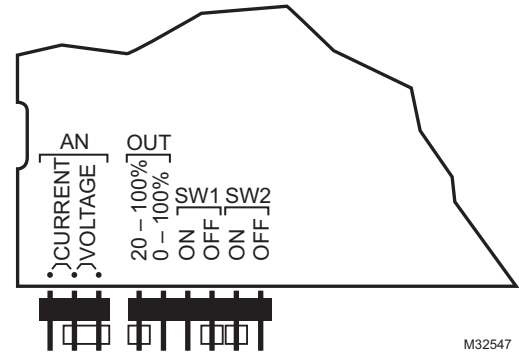

**Fig. 7. C7232 default jumper settings.**

# APPENDIX

## IMPORTANT

This page is only for models with date code prior to 0309.

## Pre 0309 Date Code Jumper Settings

### Input Signal

The C7232 Sensors have an adjustable range. These ranges are determined by the SW2 and OUT1 jumper settings (see Table 6).

NOTE: When choosing analog output, be sure to set the SW1 jumper to the On position.

**Table 6. CO<sub>2</sub> Range Jumper Settings for models with date code prior to 0309.**

Jumper	Setting	Jumper SW1		Jumper SW2	
		On <sup>a</sup>	Off	On <sup>a</sup>	Off
OUT1 <sup>b</sup>	AN1	X	— <sup>c</sup>	0 to 1000	0 to 2000
	AN2 <sup>a</sup>	X	— <sup>c</sup>	500 to 1500	500 to 2000
Relay Switching <sup>b</sup>		X		800 <sup>d</sup>	1200 <sup>d</sup>
			X	1000 <sup>d</sup>	

<sup>a</sup> Setting when shipped from the factory.

<sup>b</sup> OUT1 jumper setting does not affect the Relay Switching.

<sup>c</sup> The analog output will not work properly when SW1 is Off.

<sup>d</sup> When the level reaches this value, the contacts close; when the level drops 100 ppm below this value, the contacts open.

### Output Signal

The output signal can be adjusted for 0/2-10 Vdc or 0/4-20 mA (see Table 7).

**Table 7. Output Signal Jumper Settings for models with date code prior to 0309.**

AN1 and AN2 (set both the same)	OUT	
	0-100%	20-100%
Voltage	0-10Vdc	2-10Vdc
Current	0-20 mA	4-20 mA

NOTES:

- On duct models with date code prior to 0309, remove the screw holding the board in place to view jumper settings on reverse. (See Fig. 8.)
- The CO<sub>2</sub> settings and the output signal settings are independent of each other. 0-100% and 20-100% are simply markings for the OUT jumper settings on the sensor (to differentiate between the two voltage and the two current ranges) and do not refer to or alter the ppm range chosen.

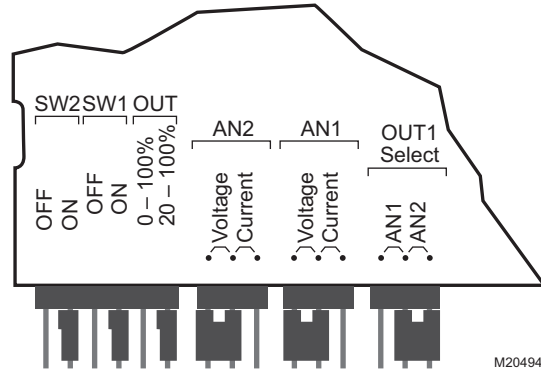

**Fig. 8. C7232 default jumper settings for models with date code prior to 0309.**





By using this Honeywell literature, you agree that Honeywell will have no liability for any damages arising out of your use or modification to, the literature. You will defend and indemnify Honeywell, its affiliates and subsidiaries, from and against any liability, cost, or damages, including attorneys' fees, arising out of, or resulting from, any modification to the literature by you.

**Home and Building Technologies**

In the U.S.:

Honeywell

1985 Douglas Drive North

Golden Valley, MN 55422-3992

[customer.honeywell.com](http://customer.honeywell.com)

**Honeywell**

® U.S. Registered Trademark  
© 2017 Honeywell International Inc.  
63-2571-16 M.S. Rev. 07-17  
Printed in United States



# MicroMetl

---

MicroMetl Indianapolis  
3035 N. Shadeland Ave., Suite 300  
Indianapolis, IN 46226  
1.800.MMC.HVAC (EST)  
[indycustomerservice@micrometl.com](mailto:indycustomerservice@micrometl.com)

MicroMetl Longview  
201 Kodak Blvd.  
Longview, TX 75602  
1.903.248.4800 (CST)  
[longviewcustomerservice@micrometl.com](mailto:longviewcustomerservice@micrometl.com)

MicroMetl Sparks  
905 Southern Way  
Sparks, NV 89431  
1.800.884.4662 (PST)  
[sparkscustomerservice@micrometl.com](mailto:sparkscustomerservice@micrometl.com)