



MicroMetl

Economizer
ECC-MRT69CA-D2
Install Guide



MicroMetl

Table of Contents

Topic	Page Number
General Install Instructions	1
Honeywell Wiring Diagram	9
Honeywell Manual	17



MicroMetl

Medium Rooftop Units
Select 12 1/2 to 27 1/2 Tons
Accessory Ultra Low Leak
Convertible Economizer

Installation Instructions

CONTENTS

- Safety Consideration
- General Descriptions
- Usage Chart, Package Contents, Sensors
- Accessories and Compliance
- Installation
- Economizer Performance Charts
- Economizer Wiring Diagrams
- 48/50 LC07 Wiring
- Enthalpy Accessory
- Differential Return Sensor Accessory
- Title 24 High Temp Limit
- Demand Control Ventilation
- Remote Fault Detection & Diagnostics
- Economizer Jade Controller
- Programming Jade W7220 Controller
- Controller Menu Structure
- Checkout Tests & Controller Terminals
- Start-Up and Operation
- Troubleshooting

SAFETY CONSIDERATIONS

Installation of this accessory can be hazardous due to system pressures, electrical components and equipment, and equipment locations (such as a roof or elevated surface). Only trained qualified installers and service technicians should install, start-up, and service this equipment.

When installing this accessory, observe precautions in the literature and on any labels attached to the equipment and all other safety precautions may apply.

- Follow all safety codes.
- Wear safety glasses and work gloves.
- Use care in handling and installing the accessory.

It is important to recognize safety information. This is the safety-alert symbol . When you see this symbol on the unit and in instructions or manuals, be alert to the potential for personal injury.

Understand the signal words DANGER, WARNING, CAUTION, and NOTE. These words are used with the safety-alert symbol. DANGER identifies the most serious hazards which will result in severe personal injury or death. WARNING signifies hazards which could result in personal injury or death. CAUTION is used to identify unsafe practices, which may result in minor personal injury or product and property damage.

NOTE is used to highlight suggestions which will result in enhanced installation, reliability, or operation.

Read these instructions completely before attempting to install the Accessory Ultra Low Leak Economizer.

 **WARNING**

ELECTRICAL SHOCK HAZARD
Failure to follow this warning could cause personal injury or death. Before performing service or maintenance operations on the unit, always turn off main power switch to unit and install lock(s) and lockout tag(s). Unit may have more than one power switch. Ensure electrical service to rooftop unit agrees with voltage and amperage listed on the unit rating plate.

 **CAUTION**

CUT HAZARD
Failure to follow this caution may result in personal injury. Sheet metal parts may have sharp edges or burrs. Use care and wear appropriate protective clothing, safety glasses and gloves when handling parts and servicing roof top units.

 **CAUTION**

Failure to follow this caution may result in personal injury and damage to the unit. Cover the duct opening as a precaution so objects cannot fall into the return duct opening. Be sure to remove the cover when installation is complete.

GENERAL

The Economizer system utilizes the latest technology available for integrating the use of free cooling with mechanical cooling for packaged rooftop units. The code compliant Jade W7220 control system optimizes energy consumption, zone comfort, and equipment cycling by operating the compressors when the outdoor-air is too humid, integrating the compressor with outdoor air when free cooling is available, and locking out the compressor when outdoor-air temperature is too cold. Demand control ventilation is supported.

This Economizer can be used with 1 or 2 speed indoor fan motor units.

The Economizer system utilizes gear-drive technology with a direct-mount spring return actuator that will close upon loss of power. The Economizer system comes standard with fault detection and diagnostics (FDD), an outdoor air sensor, and mixed air temperature sensor (also called supply air temperature sensor). Outdoor enthalpy, indoor (return) dry bulb or enthalpy, and CO2 sensors are available for field installation. See Table 5 for sensor usage.

Standard integrated barometric relief dampers provide natural building pressurization control. An optional power exhaust system is available for applications requiring even greater exhaust capabilities. The power exhaust set point is adjustable at the Economizer controller.

Unpack and inspect economizer contents from carton. Contact MicroMetl immediately if any parts are missing or damaged.

IMPORTANT: These economizers meet all economizer damper requirements as specified in ASHRAE 90.1, IECC and California's Title 24. Economizer must be installed square to avoid damper leakage or damper binding. Squareness tolerance is $\pm 1/32$ inch.

IMPORTANT: Read these instructions completely before attempting to install accessory economizer.

Table 1

Unit	*Cabinet Height	Economizer Part No.	Blank Off Used
Short Cabinet	49 3/8"	ECC-MRT69CA-D2*H	No
Tall Cabinet	57 3/8"		Yes

*Height includes base rail.

Table 2 - Packaging List

1	Economizer, Assembled
1	Shroud, Assembled
1	OA Hood Top
1	OA Hood Base
2	OA Hood Sides
3	Hood Filter Dividers
4	Hood Aluminum Filters
1	Upper Panel w/ Relief Damper (For Vertical Discharge)
1	Bottom Panel w/ Return Opening (For Horizontal Discharge)
1	Side Panel (To Cover Horizontal Return Duct Openings Unit. For Horizontal Application Only)
1	*Outside Air Blank Off Panel (8" Tall)
1	W7220 Controller w/ Harness*
1	9901-2021 Mixed (Supply) Air Temperature Sensor*
1	9901-2021/2022 Outside Air Temp Sensor**
1	9962-0570 Harness*
1	Hardware Bag (Tapped to OA damper blades)

*Used on 57 3/8" tall units only.

Shipped in Hardware bag

**OA Sensor Tapped to unit

Table 3 - Economizer Sensor Usage

APPLICATION	ECONOMIZER WITH OUTDOOR AIR SENSOR
	Accessories Required
Outdoor Air Dry Bulb	9901-2021 outdoor air dry bulb sensor is field installed on "D2DH" economizer.
Single Enthalpy	9901-2022 outdoor air enthalpy sensor is field installed on "D2EH" economizers
Mixed Air Sensor	9901-2021 provided with economizer and field installed in blower compartment.
Differential Dry Bulb or Enthalpy	9901-2022-DIFF JC2 this will have to be order separately*

* Differential (return) sensor is required by IECC 2015 Section C403.2.4.7.1

* Includes 9901-2022 sensor and wiring harness.

MicroMetl accessories simplify and minimize procedures on rooftop applications. Read these instructions completely before beginning. These economizers are designed to work for both vertical and horizontal applications. Follow the instructions for the application you require.

VERTICAL INSTALLATION

- Turn off unit power supply and install lockout tag.
- Prepare the unit for economizer installation:
 - For units with 2 position damper installed, remove the outside air hood. Unplug the damper actuator and remove assembly from unit.
 - For units with manual damper installed, remove the manual damper and hood.
- Remove the upper panel and bottom panel (provided with the HVAC unit) on the end of the unit to expose the return section. (See Fig. 1.) Save the screws for use later when replacing the panel. The panels can be discarded.
- Remove the unit's left side corner post and left side panel from the unit to allow for easy economizer installation. (See Fig. 2.)

- Install economizer, with shroud attached as shown in See Figs 3 and 7, into the return air section of the unit. Be careful not to pinch the wires during installation. Bottom of economizer will rest on the base of the unit. (See Fig. 3.)

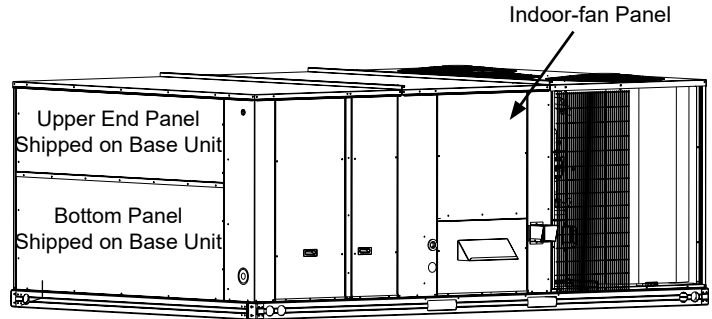

Fig. 1 - Upper and Bottom Panel on End of Unit

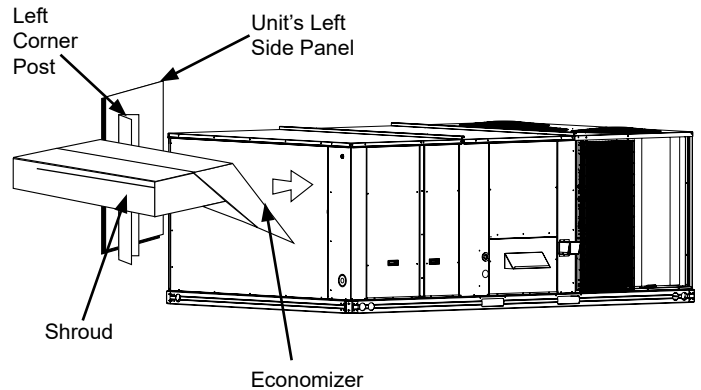

Fig. 2 - Unit Left Side Panel and Corner Post

- Reinstall the left side corner post on to the unit. Note the corner post will sit behind the economizer shroud flange. (See Fig. 4.) Screw through the corner post and through the economizer shroud. (See Fig. 3 and 4.)
- Insert provided screw through the bottom left rear of the economizer and into the unit base. Screw OA sensor tapped to economizer directly through pre-punched holes located on the left side of the shroud. Connect the pink and violet (OAT) harness if you have the 9901-2021 dry bulb sensor or the gray (S-Bus) harness to the enthalpy sensor. (See Fig. 3.) Refer to "9901-2022 Outside Air Enthalpy Sensor" section for more details on enthalpy settings. Reinstall the unit's left side panel.

- Before the economizer is secured in place on the right hand side, remove and save the 12-pin jumper plug from the unit wiring harness. (See Fig. 6.) Insert the economizer plug into the unit wiring harness plug. (See Fig. 6.)

NOTE: The 12-pin jumper plug should be saved for future use in the event that the economizer is removed from the unit. The Jumper plug is not needed as long as the economizer is installed.

- Install the bottom panel with the relief damper attached on the unit. (See Fig. 7.) Screw panel in place.

NOTE: Remove the bottom screw holding the relief blade closed.

NOTE: Access to the economizer actuator is through the HVAC unit's left side panel.

10. Install the upper economizer panel over the economizer's outside air damper, and above the bottom panel. Screw panel in place and screw panel into economizer in 2 places.
(See Figs 7 and 8.)

Note: If using economizer on 57 3/8" tall unit, install 8" outside air blank off panel above upper economizer panel, see Figure 3. Screw in place.

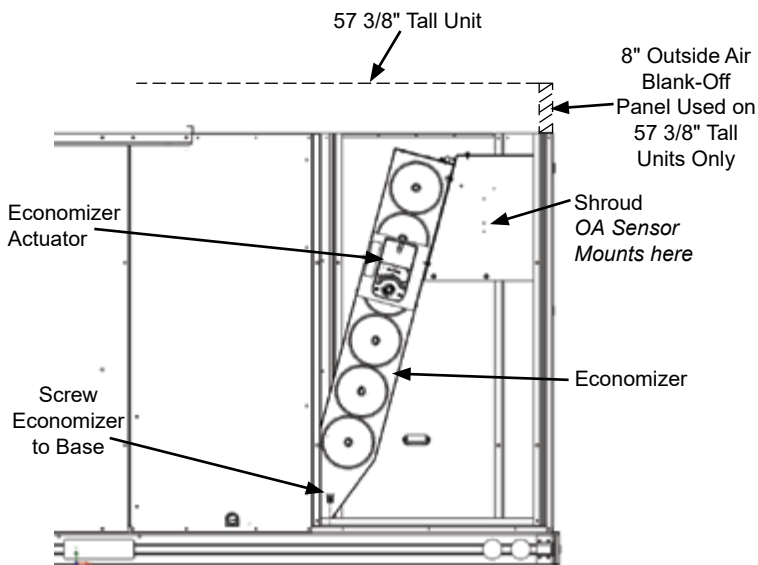

Fig. 3 - Side View

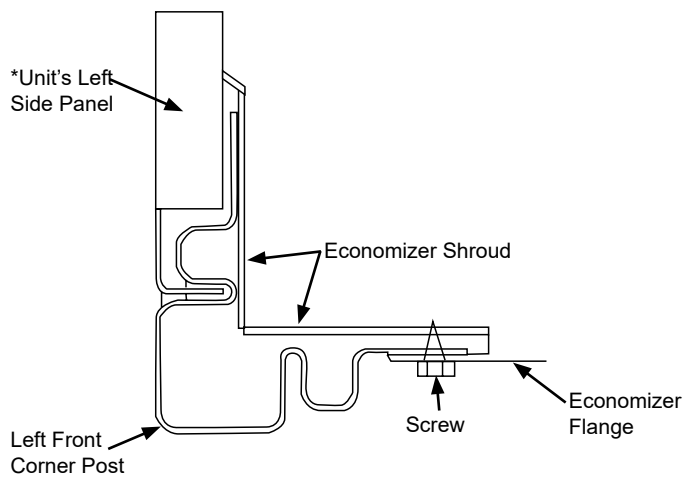

Fig. 4 - Top View

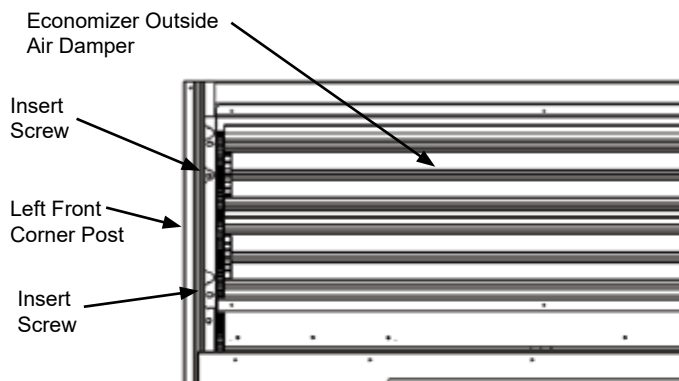

Fig. 5 - Front Left View (49 3/8" Tall Unit Shown)

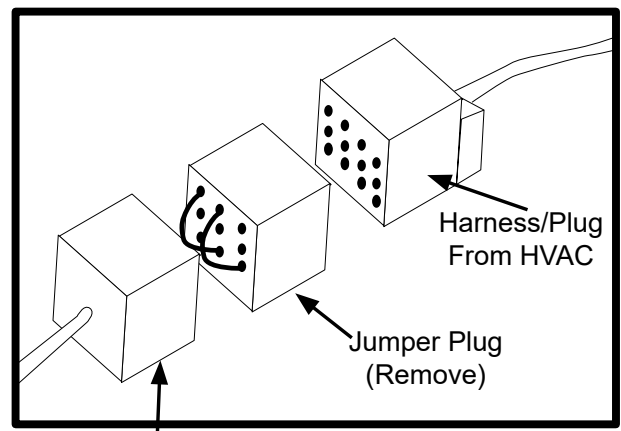

Fig. 6 - Harness and Jumper Plug

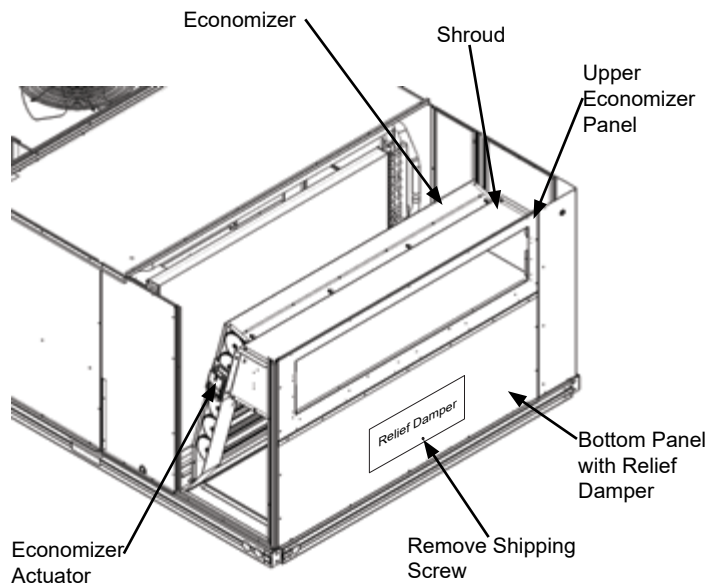

Fig. 7 - Bottom Panel Installation (49 3/8" Tall Unit Shown)

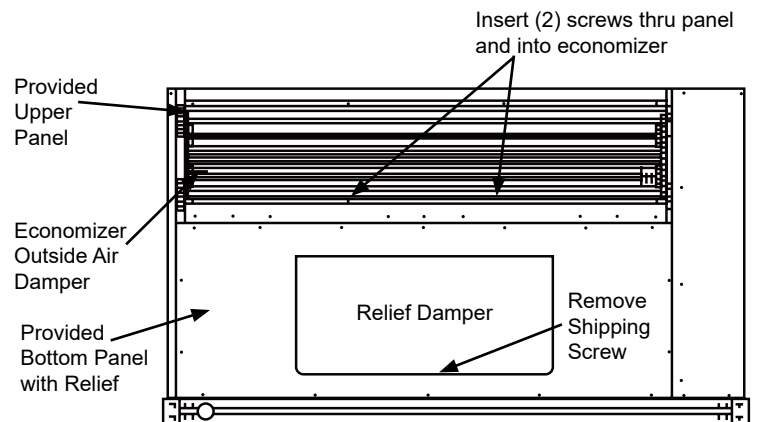

Fig. 8 - End View of Unit (49 3/8" Tall Unit Shown)

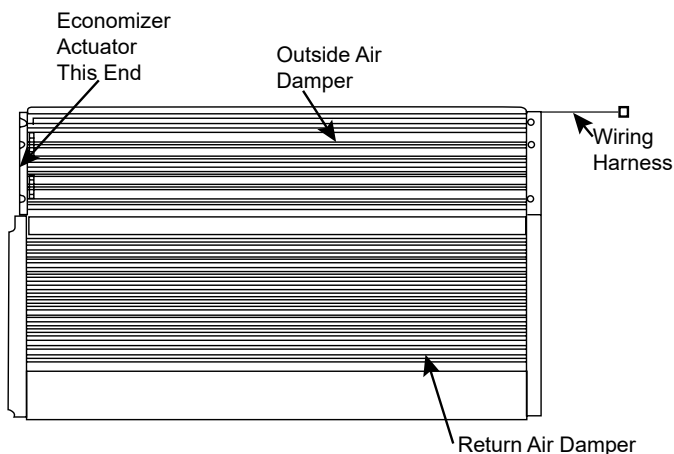

Fig. 9 - Component Locations

11. Locate the mixed (supply) air temperature sensor in the economizer hardware bag. Mount the sensor in the indoor fan section of the unit, **see Fig. 29.**
12. Assemble the outside air hood per **Fig. 13 and 14.**
 - a. Secure the left and right side to the top of the O/A hood with the screws provided. Ensure that the flange on the top of the O/A hood are over the two sides. Verify that the side flanges point outward.
 - b. Secure the bottom of the O/A hood with the flat side pointing outward.
 - c. Apply gasketing on the top, sides and bottom flanges that will secure to the panel.
 - d. Secure the bottom filter support to the bottom of the O/A hood.
 - e. Secure the filter dividers.
 - f. Make sure that the top filter is open. Then slide in the filters and flip the top filter support over it.
 - g. Secure assembled hood to the panel
 - h. Caulk corners if needed.
13. Install the hood assemblies on the unit. (**See Fig. 14 and 15.**)
14. Install the hood screens and other approved accessories.

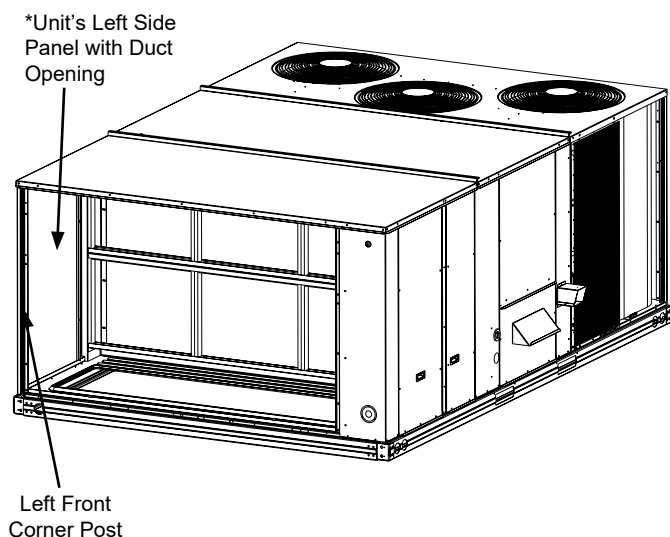

Fig. 10 - Remove Unit Corner Post and Side Panel

HORIZONTAL INSTALLATION

These economizer are designed to work in both a vertical and horizontal applications. These instructions are for a horizontal.

Special Note: *In a horizontal application, this economizer requires the return air to enter the unit underneath the outside air hood. MicroMetl also offers an ECE-MRT69CA Series economizer that allows the return air to enter the unit through the HVAC unit horizontal return opening on the side of the unit. Contact MicroMetl factory for details.*

The unit has a horizontal duct opening next to the horizontal supply duct opening. However, in this application, with an economizer, the horizontal duct will actually come into the unit underneath the outdoor air hood. (**See Fig. 16.**)

1. Turn off unit power supply and install lockout tag.
2. Prepare the unit for economizer installation:
 - a. For units with 2 position damper installed, remove the outside air hood. Unplug the damper actuator and remove assembly from unit.
 - b. For unit with manual damper installed, remove the manual damper and hood.
3. Remove the upper panel and bottom panel (*provided with the HVAC unit*). On the end of the unit to expose the return section. (**See Fig. 1.**) Save the screws for use later when replacing the panel. The panels can be discarded.
4. Remove the unit's left side corner post and left side panel from the unit to allow for easy economizer installation. (**See Fig. 10.**)

NOTE: *The unit's left side panel has a return air duct opening in it, but this panel / duct opening will not be used in this application and can be discarded.*

5. Install economizer with shroud attached, as shown in **Fig. 2**, into the return air section of the unit. Be careful not to pinch the wires during installation. Bottom of economizer will rest on the base of the unit. Screw OA sensor tapped to economizer directly through pre-punched holes located on the left side of the shroud. Connect the pink and violet (OAT) harness if you have the 9901-2021 dry bulb sensor or the gray (S-Bus) harness to the enthalpy sensor. (**See Fig. 3.**) Refer to "9901-2022 Outside Air Enthalpy Sensor" section for more details on enthalpy settings.
6. Reinstall the left side corner post on to the unit. Note the corner post will sit behind the economizer shroud flange. (**See Fig. 4.**) Screw through the corner post and through the economizer shroud. (**See Fig. 4 and 5.**)
7. Insert provided screw through the bottom left rear of the economizer and into the unit base. (**See Fig. 3.**) Install the new (*provided*) left side panel without the duct opening on the unit.
8. Before the economizer is secured in place on the right hand side, remove and save the 12-pin jumper plug from the unit wiring harness. Insert the economizer plug into the unit wiring harness plug. (**See Fig. 6.**)

NOTE: *The 12-pin jumper plug should be saved for future use in the event that the economizer is removed from the unit. The jumper plug is not needed as long as the economizer is installed.*

9. Install the (provided) bottom panel with the horizontal return duct opening on the unit. (See Figs 11 and 12.) Screw panel in place
10. Install the upper economizer panel in place over the economizer's outside air damper, and above the bottom panel. Screw panel in place and screw panel into economizer in 2 places. See Fig 12.
Note: If using economizer on 57 3/8" tall unit, install 8" outside air blank off panel above upper economizer panel.
See Figure 12. Screw in place.
11. Locate the mixed (supply) air temperature sensor in the economizer hardware bag. Mount the sensor in the indoor fan section of the unit, see Fig. 29. Wire per Fig. 24 and 25.
12. Assemble the outside air hood per Fig. 13 and 14.

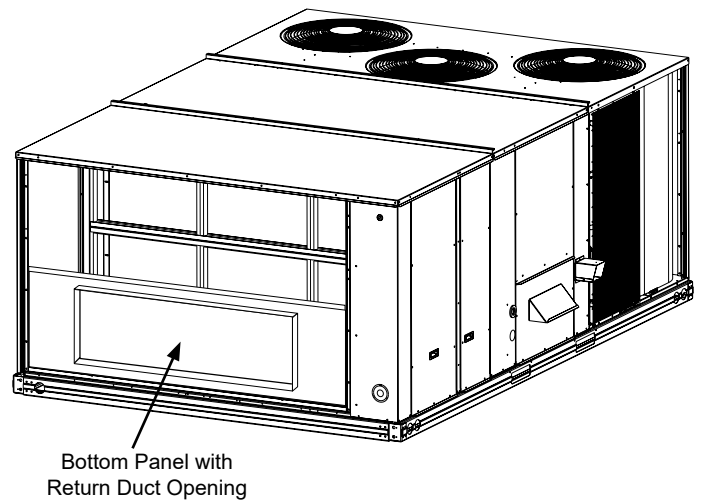

Fig. 11 - Install Bottom Panel with Horizontal Return Duct Opening

- a. Cut a 15.3" x 34.75" opening one inch from the bottom of the duct.
- b. Place the left hinge 0.2" overlap from the top of the opening. 1.63" away from the side of the opening.
- c. Secure hinge using screws provided.
- d. Slide door into bushing in secured hinge. Ensure that gasket side of door is against the duct.
- e. Slide right side door into hinge.
- f. Level out door making sure it is straight.
- g. Make sure the inner dimension between the two hinges is 37.996".
- h. Secure the right hinge to duct.
- i. Place hood over relief damper on duct using screws provided.
- j. Caulk open corners on hood.
13. Install the hood assembly onto the unit. (See Fig. 14 and 15.)
14. If barometric relief is required, remove the relief damper, hardware cloth, and brackets from the bottom panel.
See Fig. 7. Cut a 15.3" x 34.75" hole in the side of return duct and mount hardware cloth screen and relief damper assembly. See Figs. 16A and 16B.
15. Install the hood screens and other approved accessories.

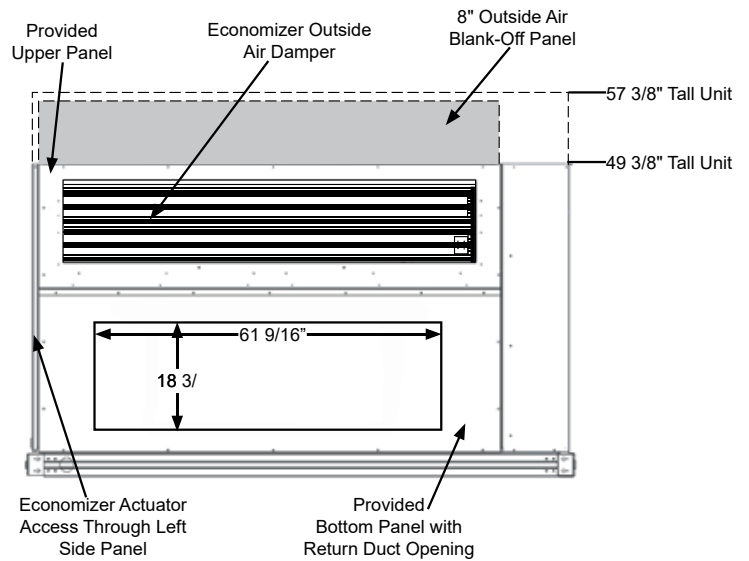
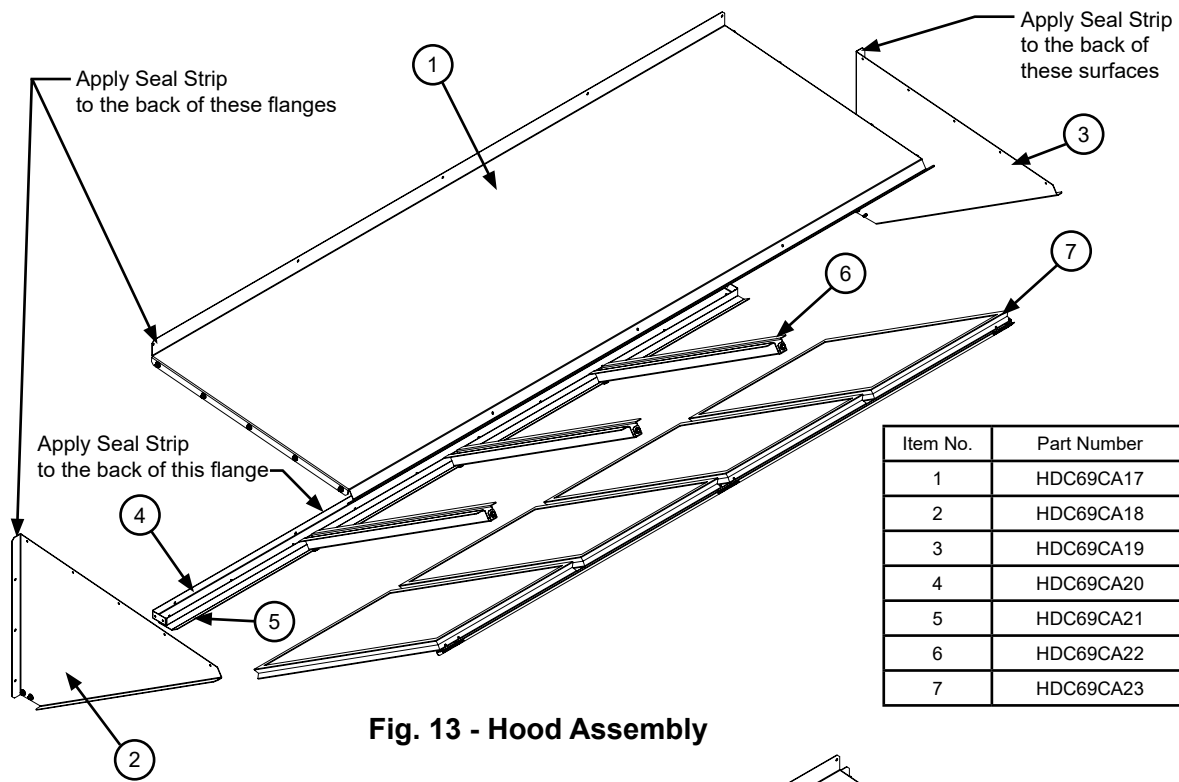

Fig. 12 - End View



Item No.	Part Number	Qty.
1	HDC69CA17	1
2	HDC69CA18	1
3	HDC69CA19	1
4	HDC69CA20	1
5	HDC69CA21	1
6	HDC69CA22	3
7	HDC69CA23	1

Fig. 13 - Hood Assembly

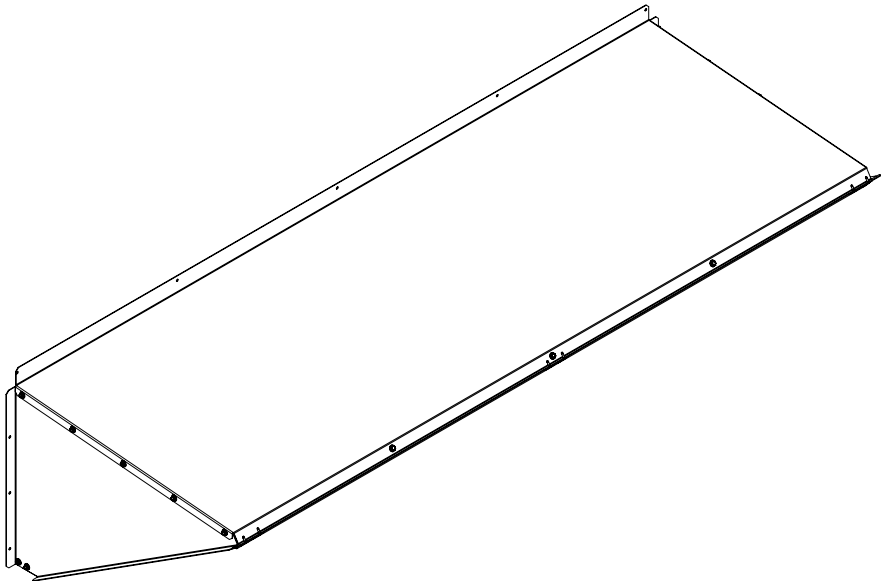
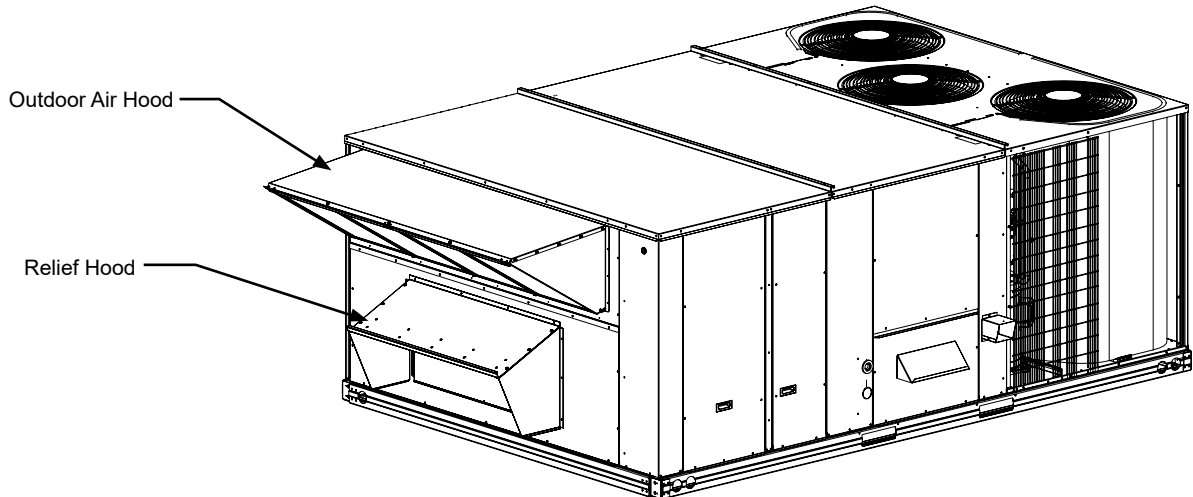
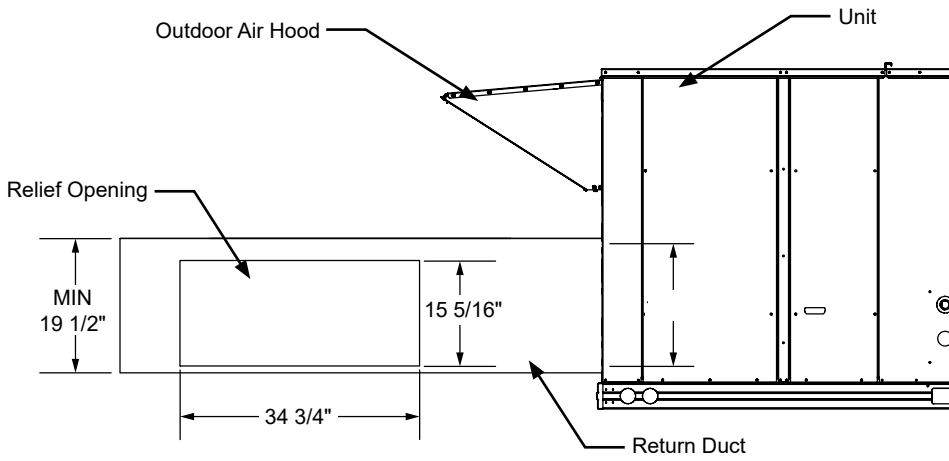

Fig. 14 - Hood Assembly - Completed



**Fig. 15 - Hood Assembly Installed (Vertical Application Shown)
(49 3/8" Tall Unit Shown)**



**Fig. 16A - Relief Damper Hole
(49 3/8" Tall Unit Shown)**

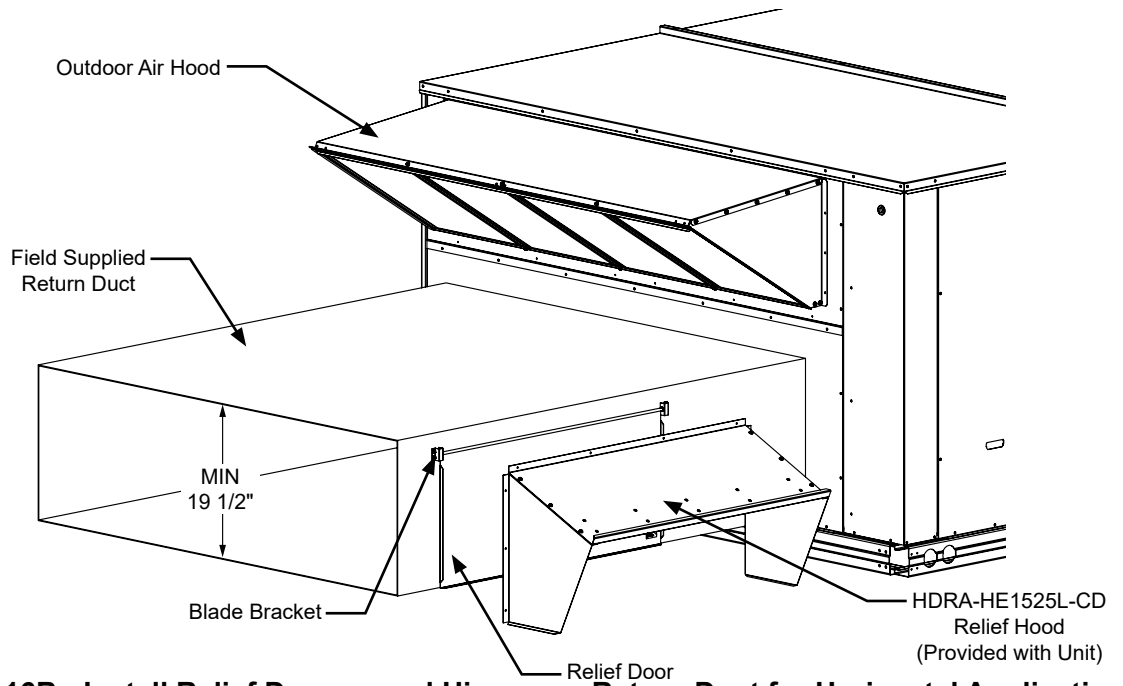

**Fig. 16B - Install Relief Damper and Hinges on Return Duct for Horizontal Application
(49 3/8" Tall Unit Shown)**

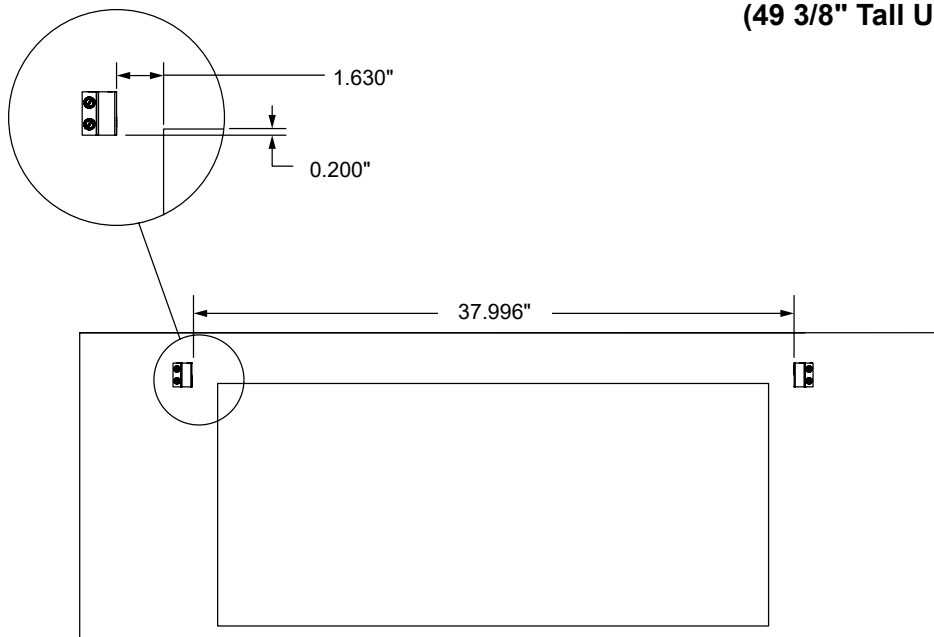

Fig. 16C - Bracket Detail View



If you have an older 48/50TC or HC unit with a Central Terminal Board.
 You will need to purchase a 1002-0475 harness or 9962-0475 harness from TX.

A. Locate the C7250 mixed (supply) air temperature sensor in the economizer hardware bag. Mount the sensor in the indoor fan section of the unit. Locate the orange and brown wires in the wire bundle in the indoor fan section. Connect these orange and brown wires to the 2-wire harness attached to the C7250 Sensor.

See Fig. 19.

Mixed air default setting is 53°F and can be adjusted from 38°F to 70°F.11.

Install the controller in the top left corner of the unit control box as shown in **Figure 19**. Screw in place through pre-punched holes.

B. Unplug the 12-pin female ECON plug currently connected to the Unit Control Board (UCB). **See Figure 20.**

C. Connect the 12-pin female ECON plug removed from the UCB to the 12-pin male plug from the controller harness. **See Figure 21.**

D. Connect the 12-pin female plug from the controller harness to ECON on the UCB. **See Figure 22.**

E. **See Figure 12** and follow wiring diagram.

F. Adjust controller setting (*minimum position, outside air, etc.*) per instructions detailed later in this instruction.

G. Reinstall the unit's panels.

H. Follow all local and other applicable codes.

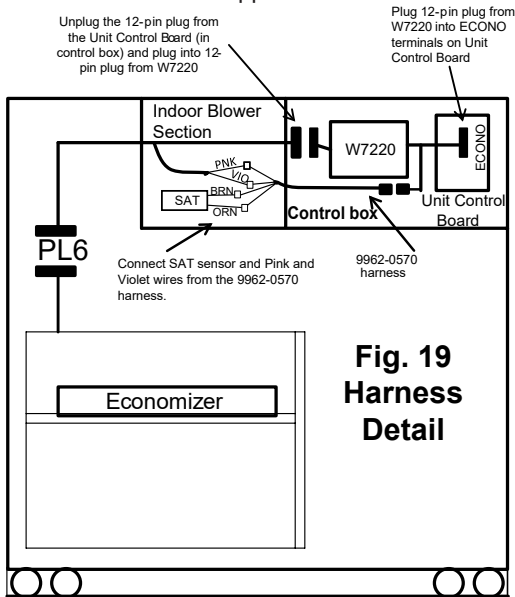

**Fig. 19
 Harness
 Detail**

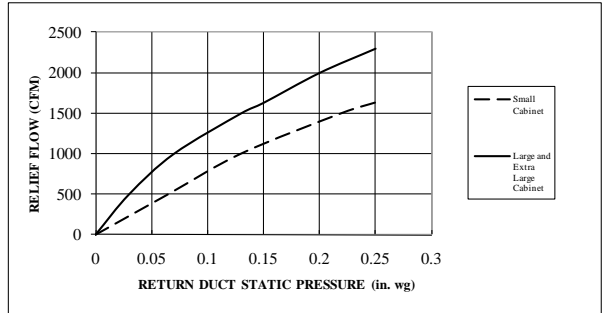

Fig. 17 - Barometric Relief Flow Capacity

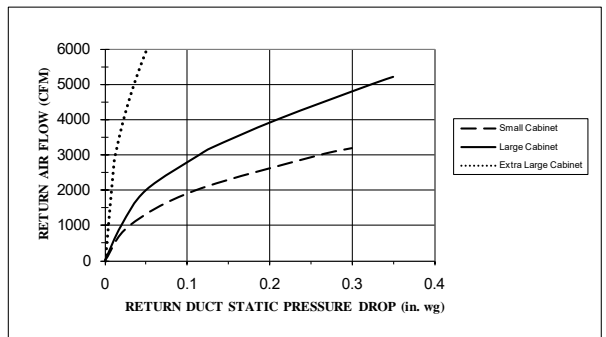

Fig. 18 - Return Air Pressure Drop

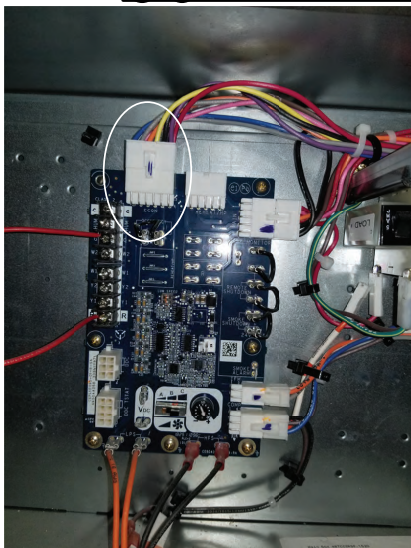

Fig. 20 - Harness Detail



Fig. 21 - Harness Detail

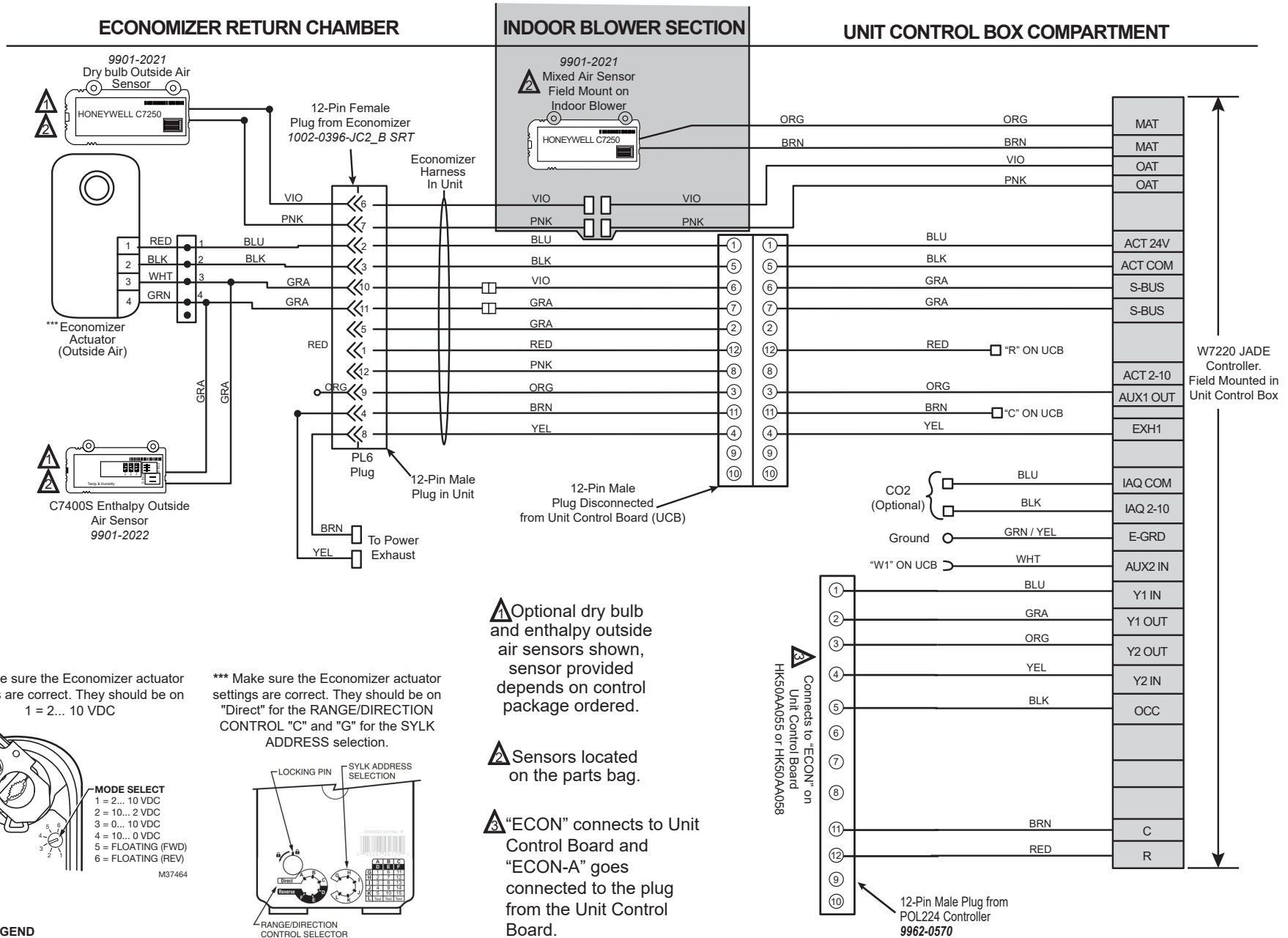

Fig. 22 - Harness Detail



MicroMet

Wiring Diagram Supplement For Installing JADE W7220 Economizer on Unit with Vane Axial Indoor Fan (with Unit Control Board HK50AA055 or HK50AA058)



⚠ Optional dry bulb and enthalpy outside air sensors shown, sensor provided depends on control package ordered.

⚠ Sensors located on the parts bag.

⚠ "ECON" connects to Unit Control Board and "ECON-A" goes connected to the plug from the Unit Control Board.

*** Make sure the Economizer actuator settings are correct. They should be on 1 = 2... 10 VDC

*** Make sure the Economizer actuator settings are correct. They should be on "Direct" for the RANGE/DIRECTION CONTROL "C" and "G" for the SYLK ADDRESS selection.

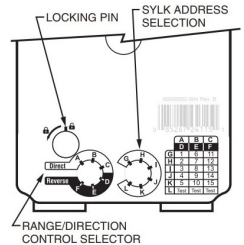
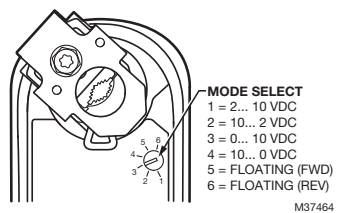

LEGEND

UCB: Unit Control Board
 MAT: Mixed Air Temperature Sensor
 OAT: Outside Air Temperature Sensor

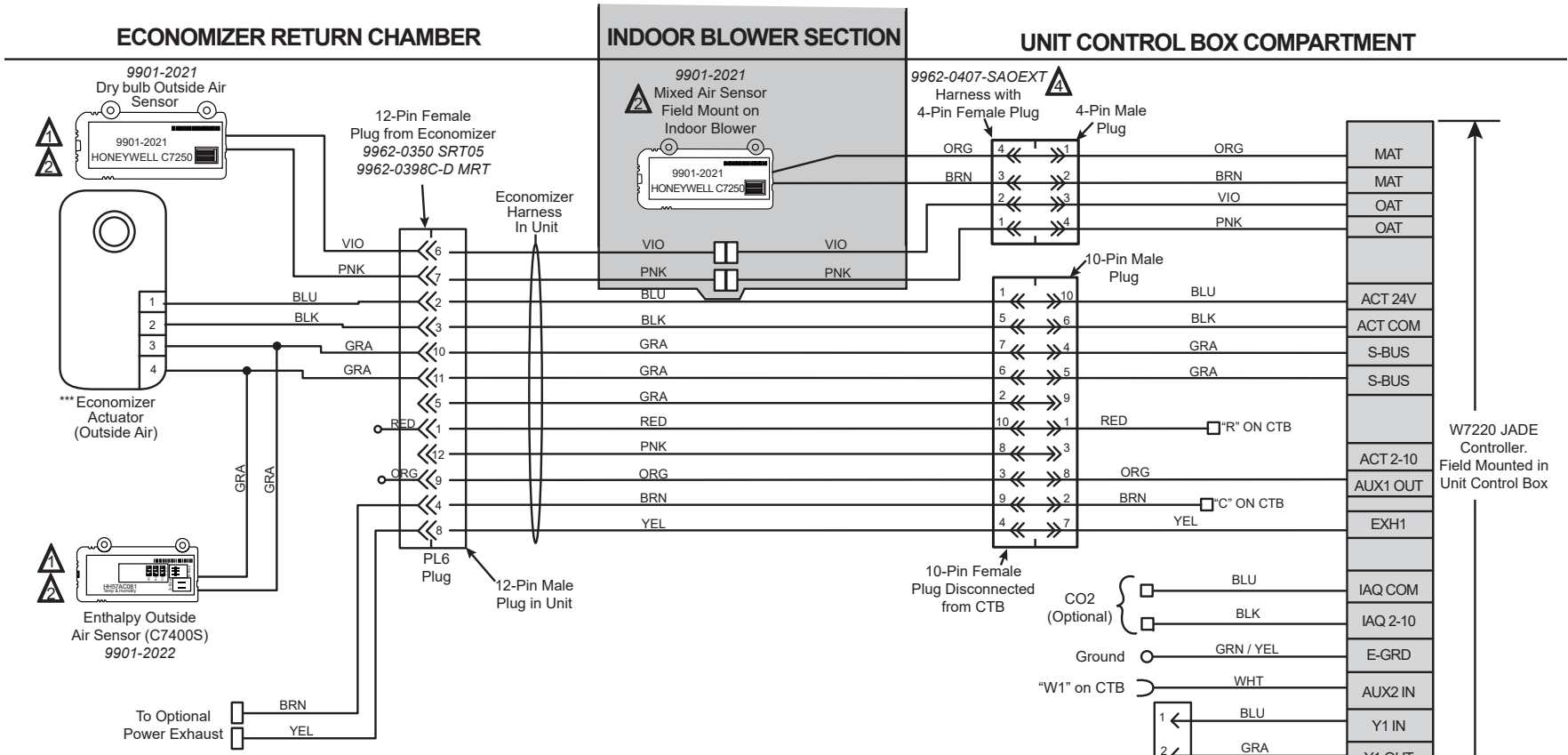

*** Make sure the Economizer actuator settings are correct. They should be on 1 = 2... 10 VDC

*** Make sure the Economizer actuator settings are correct. They should be on "Direct" for the RANGE/DIRECTION CONTROL "C" and "G" for the SYLK ADDRESS selection.

⚠ Optional dry bulb and enthalpy outside air sensors shown, sensor provided depends on control package ordered.

⚠ Sensors located on the parts bag.

⚠ "ECON" connects to Unit Control Board and "ECON-A" goes connected to the plug from the Unit Control Board.

⚠ On some models there is a separate 9962-0407-SAOEXT harness and on other models these 4 wires are a part of the standard harness attached to Jade W7220 controller.

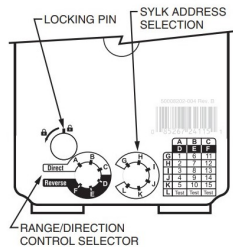
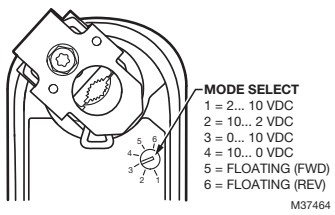

LEGEND

CTB: Central Terminal Board
 MAT: Mixed Air Temperature Sensor
 OAT: Outside Air Temperature Sensor

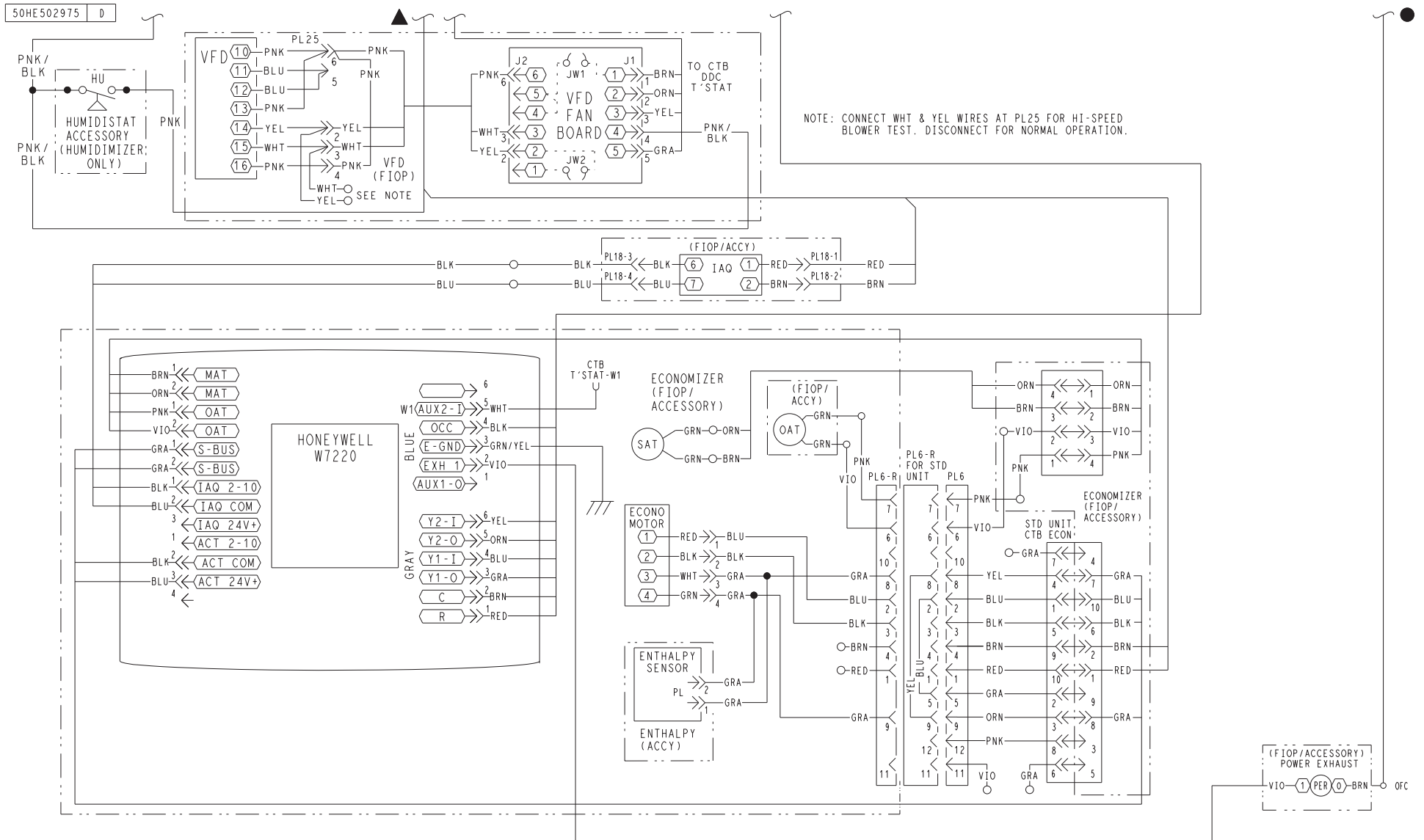



MicroMet

INSTALLING DIFFERENTIAL RETURN AIR SENSOR

The 9901-2022-DIFF JC2 differential return sensor kit must be field mounted in the system's return duct work. The kit includes a wiring harness, that connects the economizer harness in the return chamber of the unit, to the provided 9901-2022 sensor.

In addition to using the 9901-2022 (Honeywell C7400S) sensor for a single enthalpy sensor, it can also be used as a differential return enthalpy or dry bulb sensor. With dual enthalpy the **HIGH LIMIT** boundary is ES1 when there are no stages of mechanical cooling energized and HL (high limit) when a compressor stage is energized.

Important: to use the 9901-2022 sensor for differential return air, the dipswitches on the sensor must be set on ON-OFF-OFF.

When using the 9901-2022-DIFF JC2 differential return enthalpy or dry bulb temperature option, See the **California Title 24** setting requirements by region.

CALIFORNIA'S TITLE 24 HIGH TEMPERATURE LIMIT SETTINGS

California's Title 24 code requires a high temperature limit setting for all dry bulb outside air economizer change over. The temperatures vary by the region within California. See Table 9 for high limit settings.

DEVICE TYPE*	CLIMATE ZONES	REQUIRED HIGH LIMIT (ECONOMIZER OFF WHEN):
		DESCRIPTION
FIXED DRY BULB	1, 3, 5, 11-16	OAT exceeds 75°F
	2, 4, 10	OAT exceeds 73°F
	6, 8, 9	OAT exceeds 71°F
	7	OAT exceeds 69°F
DIFFERENTIAL DRY BULB	1, 3, 5, 11-16	OAT exceeds RA Temp.
	2, 4, 10	OAT exceeds -2°F
	6, 8, 9	OAT exceeds -4°F
	7	OAT exceeds -4°F
FIXED ENTHALPY† + FIXED DRY BULB	ALL	OAT exceeds 28 Btu/lb of dry air or OAT exceeds 75°F

* Only the high limit control devices listed are allowed to be used and at the setpoints listed. Others such as Dew Point, Fixed Enthalpy, Electronic Enthalpy, and Differential Enthalpy Controls, may not be used in any climate zone for compliance with Section 140.4(e)1 unless approval for use is provided by the Energy Commission Executive Director.

† At altitudes substantially different than sea level, the Fixed Enthalpy limit values shall be set to the enthalpy value at 75°F and 50% relative humidity. As an example, at approximately 6,000 foot elevation, the fixed enthalpy limit is approximately 30.7 Btu/lb.

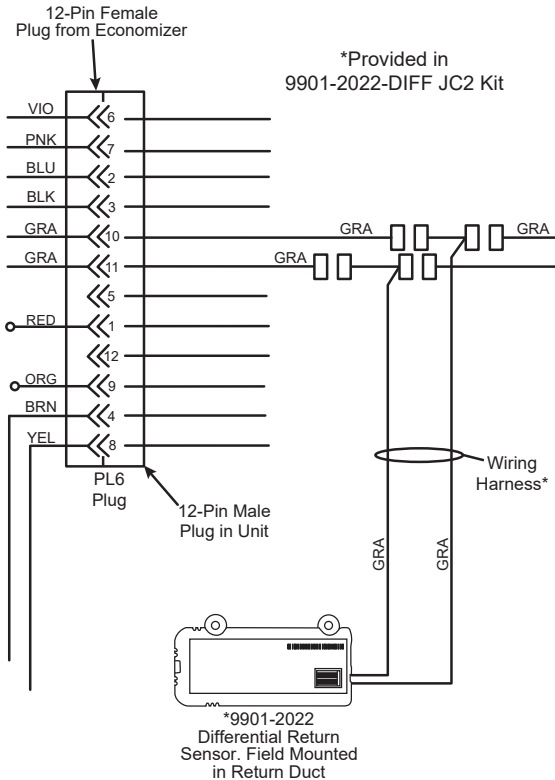

Wiring Differential Return Air Sensor

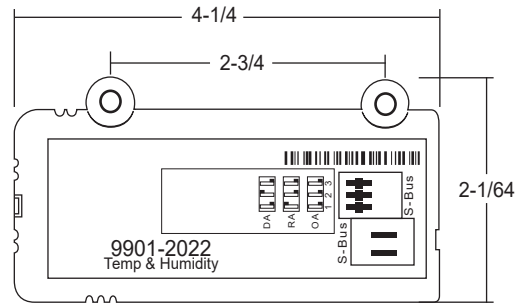

9901-2022 (C7400S)
Dimensional, connection and switching information

DEMAND CONTROL VENTILATION

Refer to economizer wiring diagram and DCV instructions if demand control ventilation (CO2 sensor) is used. CO2 sensor will wire into the blue and black connection (IAQ COM & IAQ 2-10) at the Jade controller. If a field installed CO2 sensor is connected to the economizer controller, a demand-controlled ventilation strategy will operate automatically. As the CO2 level in the space increases above the setpoint (on the economizer controller), the minimum position of the dampers will be increased proportionally, until the Maximum Ventilation setting is reached. As the space CO2 level decreases because of the increase in fresh air, the outdoor damper will follow the higher demand condition from the DCV mode or from the free cooling mode.

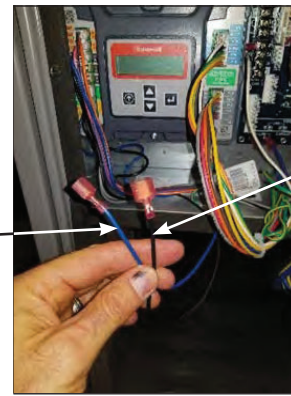

Blue Wire
IAQ COM

Black Wire
IAQ 2-10 Vdc

CO2 wiring connections to Jade controller

REMOTE (DOWNSTAIRS) MONITORING OF CONTROLLER'S FAULT DETECTION AND DIAGNOSTICS

Many codes including IECC, Tittle 24, and ASHRAE 90.1 require that the economizer's faults be accessible by operating or service personal or annunciated locally on zone thermostat. To setup remote monitoring on the controller, under **SYSTEM SETUP**, **AUX1-OUT** must be set to **SYS**.

The latest versions of Honeywell's **TH8321WF** or **TH8321R** thermostats are options for meeting this requirement. Follow instructions provided with Honeywell thermostat.

Another option that is acceptable to some codes is an annunciator light visible by service personnel. Below is the typical wiring to the Jade controller. Refer to codes for proper labeling of light.

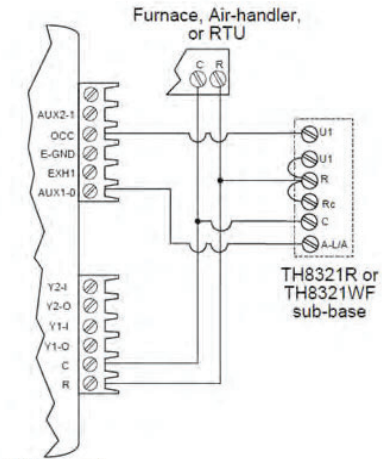

W7220 Jade economizer

Thermostat Wired For Remote FDD

W7220 Economizer Controller Module



JADE Setting: Under the "System Setup" menu, set AUX1-OUT to "SYS" which will close JADE relay on fault detection

Annunciator Light Wired for Remote FDD

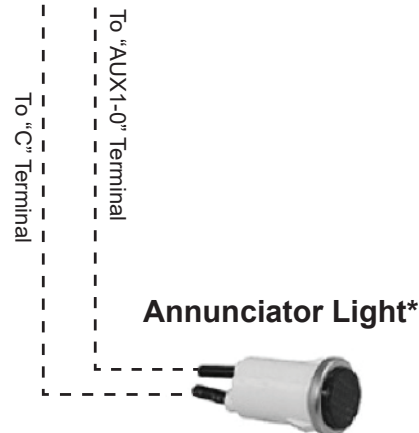

Examples of annunciator lights would include these Grainger lights:

- Item #20C841
- Item #20C846



MicroMetl Instructions for 48/50LC 07-12 Units Only

Important: This page is for economizer installation instructions on 48/50LC 07-12 units only.

Step LC1 Follow steps 1 through 10 earlier in these instructions.

Step LC2 The 48/50LC 07-12 units require different wiring than is factory attached to the W7220 Jade controller. Disconnect the complete wiring harness factory attached to the W7220 Jade controller, as shown. Set this harness aside as a small section may be used for LC units.

Note: The complete 4-wire 9962-0407-SAOEXT harness provided with the economizer will also NOT be used on the 48/50LC 07-12 units. However, a small section may be used for the MAT.

Step LC3 The 48/50 LC 07-12 units that do not have a factory installed economizer will have a new Jade W7220 controller wiring harness shipped in the control box section of the HVAC unit. This harness, Carrier part number 48LCHSRADH—A00.

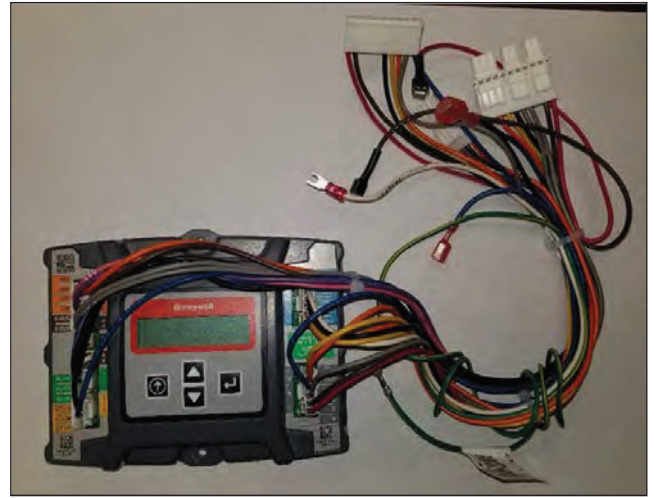

**Remove Complete Harness
Factory-Attached to W7220 Controller**



**9962-0407-SAOEXT Not Used
on 48/50LC 07-12 Units**

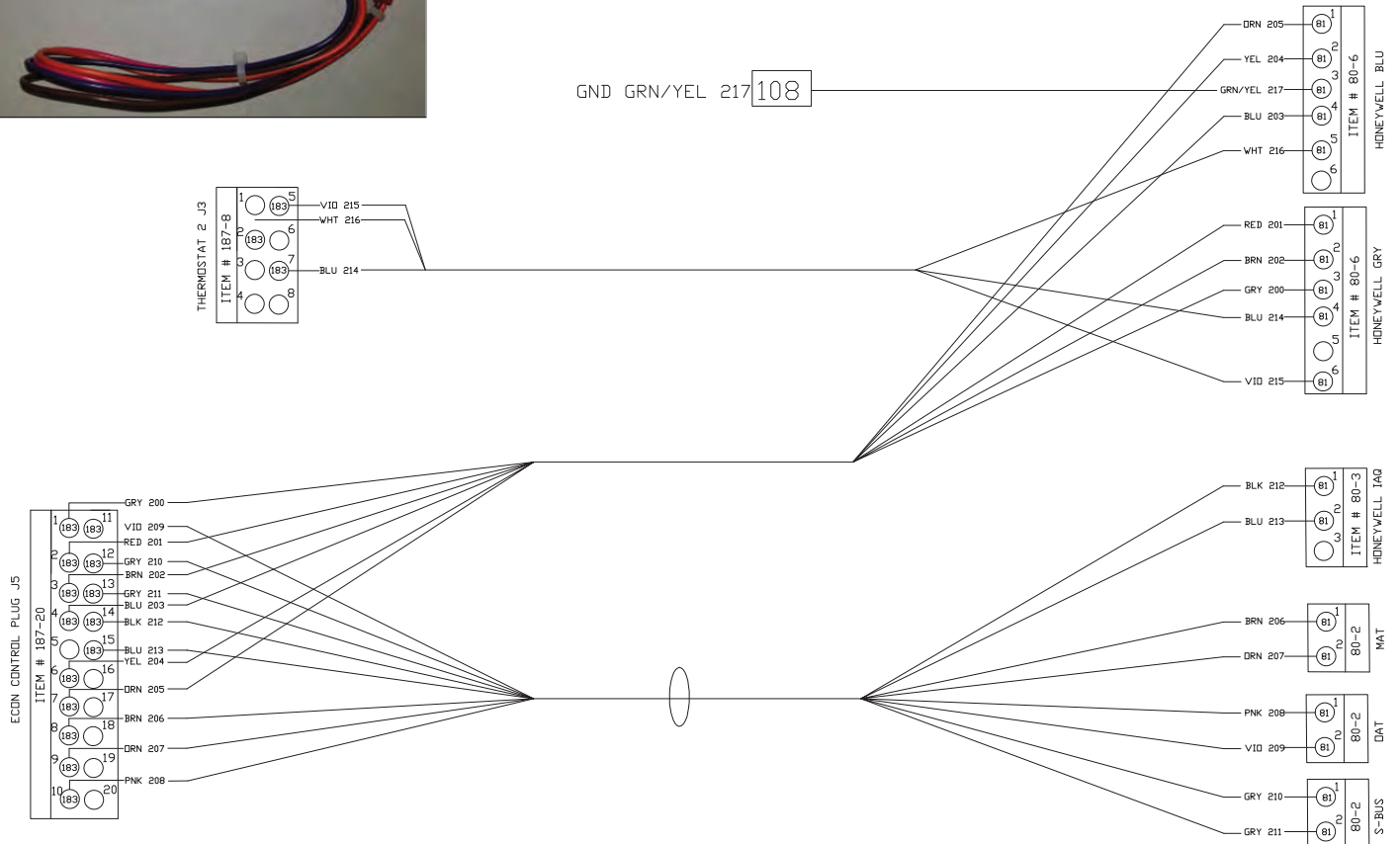

48LCHSRADH--A00 W7220 Controller Harness Shipped With 48/50LC 07-12 Units

Important: This page is for economizer installation instructions on 48/50LC 07-12 units only.

Step LC4 The connectors on the right side of 48LCHSRAD—A00 harness attach to the Jade W7220 controller installed in the unit control box. 48LCHSRAD—A00 harness connectors are labeled to easily identify the plug-in location on the controller.

Step LC5 Locate the Compressor Staging Controller (CSC) board in the HVAC unit. When a field-installed economizer is used the J5 jumper on the CSC must be removed. Remove the J5 jumper.

Step LC6 The connectors on the left side of 48LCHSRAD—A00 harness attach to the units CSC board. Connect J3 and J5 plugs to the CSC board.

Step LC7 Screw the green wire with yellow stripes in the 48LCHSRAD—A00 harness to the control box (Ground).
Step LC8 Mount the provided 9901-2021 mixed air temperature (MAT) sensor (C7250) to the indoor blower. Confirm that the screws do not interfere with blower rotation.

IMPORTANT: The brown and orange wires in the indoor blower section for the mixed air sensor have spade terminals, and will not connect directly to the MAT sensor, which requires a 2-pin plug.



Photo of 48LCHSRAD—A00 W7220 Controller Harness Shipped With 48/50LC 07-12 Units

Some Economizer Models:

Locate brown and orange MAT wires on the 9962-0407-SAOEXT harness. Cut the orange and brown leading to the 2-pin MAT plug. Splice these 2 wires to the brown and orange wires in the indoor blower section. Connect the 2-pin plug to the mixed air sensor.

Other Economizer Models:

Locate the brown and orange wire on the original Jade harness. Disconnect the terminals on the brown and orange MAT wires. Connect these terminals to the brown and orange wires factory installed in the blower section. Connect the 2-pin plug to the mixed air sensor.

Step LC9 Connect the 10-pin female ECON plug removed from the CTB to the 10-pin male plug from the Jade controller harness, then connect the 10-pin female plug from the Jade controller harness to ECON on the CTB.

Connect the white wire from the controller harness to the W1 terminal, the red wire to “R” terminal, and brown wire to “C” terminal on the CTB.

Use Part of 9962-0407-SAOEXT Harness for MAT Sensor on LC Units

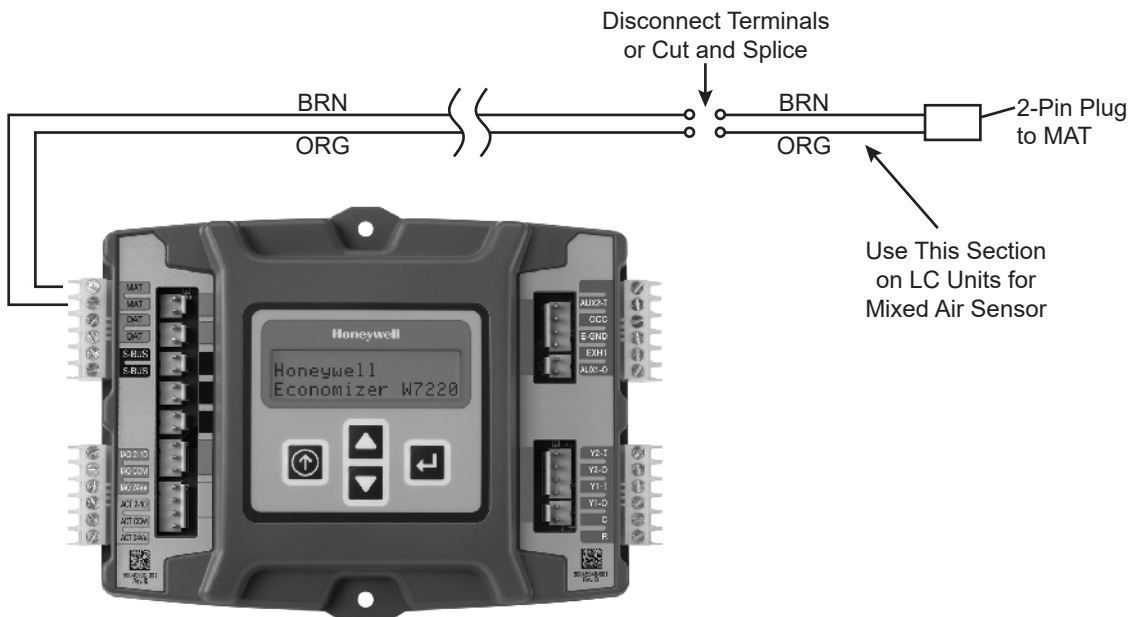

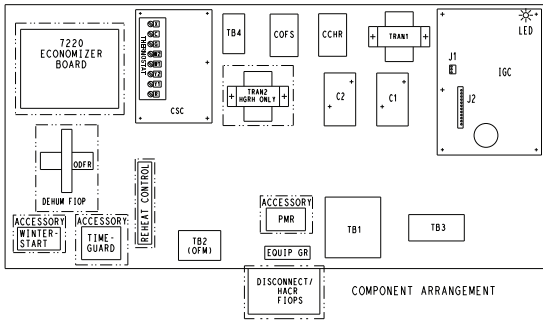

NOTES:
1. TERMINAL BOARD SCHEMATIC LAYOUT DOES NOT MATCH ACTUAL TERMINAL BOARD TO SIMPLIFY CIRCUIT TRACES.

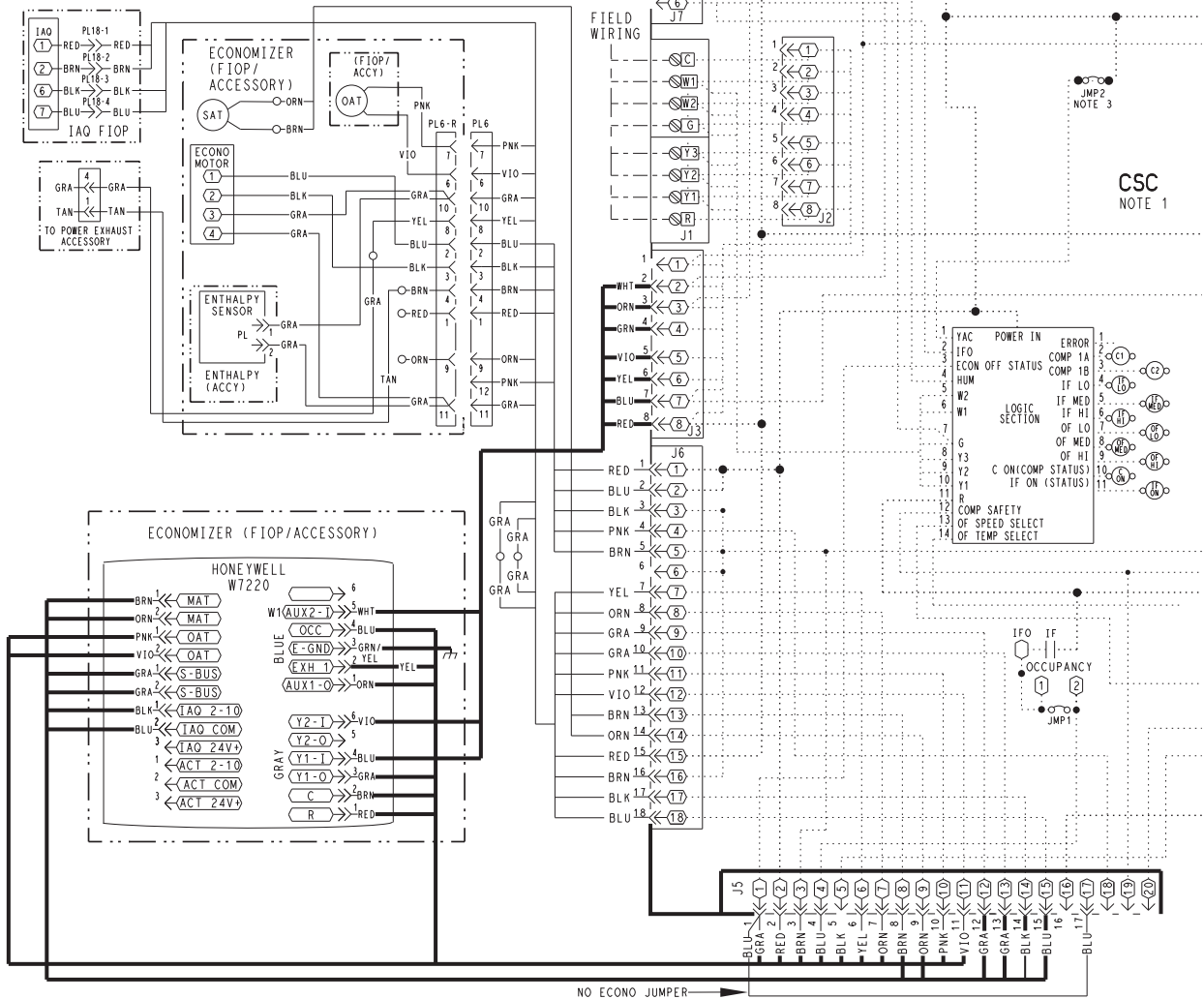

Typical Wiring Diagram For 48/50LC 07-12 Units

NOTES:

1. Harness shown in bold is 48LCHSRADH--A00 harness, which is shipped in the control box of 48/50LC 07-12 units and must be field connected to the W7220 controller provided with the economizer.
2. Harness attached to the W7220 controller from the Carrier factory is removed and not used with 48/50LC 07-12 units



W7220 ECONOMIZER

The economizer controller used on electro mechanical units is the Honeywell W7220 which is to be located in the RTU base unit's Control Box. See Fig 41 for button description of the W7220 controller. The W7220 controller provide the following:

- 2-line LCD interface screen for setup, configuration and troubleshooting.
- On-board fault detection and diagnostics
- Sensor failure loss of communications identification
- Automatic sensor detection
- Capabilities for use with multiple-speed indoor fan systems

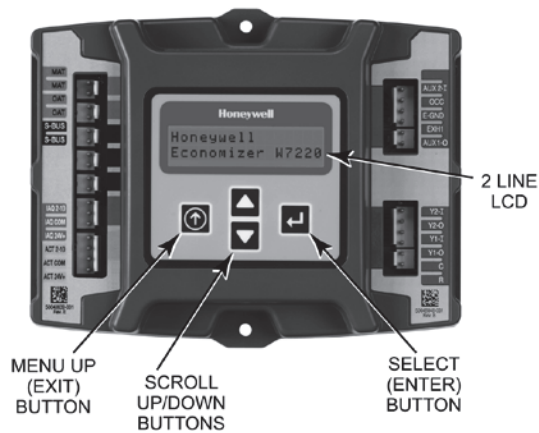

Fig. 41 - W7220 Controller

User Interface

The user interface consists of a LCD display and a 4-button keypad on the front of the economizer controller.

Keypad

The four navigation buttons (see Figure 41) are used to scroll through the menus and menu items, select menu items, and to change parameter and configuration settings.

Using the Keypad with Menus

To use the keypad when working with menus:

- Press the ▲ (Up arrow) button to move to the previous menu.
- Press the ▼ (Down arrow) button to move to the next menu.
- Press the ↵ (Enter) button to display the first item in the currently displayed menu.
- Press the ⏪ (Menu Up/Exit) button to exit a menu's item and return to the list of menus.

Using the Keypad with Settings and Parameters

To use the keypad when working with Setpoints, System Setup Advanced Settings, Checkout Tests and Alarms:

1. Navigate to the desire menu.
 2. Press the ↵ (Enter) button to display the first item in the currently displayed menu.
 3. Use the ▲ and ▼ buttons to scroll to the desired parameter.
 4. Press the ↵ (Enter) button to display the value of the currently displayed item.
 5. Press the ▲ button to increase (change) the displayed parameter value.
 6. Press the ▼ button to decrease (change) the displayed parameter value.
- NOTE:** When values are displayed, pressing and holding the ▲ or ▼ button causes the display to automatically increment.
7. Press the ↵ (Enter) button to accept the displayed value and store it in nonvolatile RAM.
 8. "CHANGE STORED" displays.
 9. Press the ↵ (Enter) button to return to the current menu parameter.
 10. Press the ⏪ (Menu Up/Exit) button to return to the previous menu.

Menu Structure

Table 11 illustrates the complete hierarchy of menus and parameters for the economizer system.

The Menus in display order are:

- STATUS
- SETPOINTS
- SYSTEM SETUP
- ADVANCED SETUP
- CHECKOUT
- ALARMS

IMPORTANT NOTE: The default setting on the W7220 controller is for a "Fan Type" with 2 speed. If your unit is 1 speed, the setting under SYSTEM SETUP > FAN TYPE must be changed to 1 speed. *NOTE: Some models' default may vary.*



MicroMetl

PROGRAMMING THE JADE W7220 CONTROLLER

The next several pages detail the different status displays, setpoints, setup, and alarms available on the controller. This list below and Table 10 summarizes the inputs required for a standard application with a single outside air sensor.

NOTE: *instead of setting the SETPOINTS you can use the defaults already set in the Jade controller – see default settings below. See Table 10 for summarized standard settings or for more detail see Table 11 – Menu Structure.*

SYSTEM SETUP

- **INSTALL:** Allows you to set the current date. Use the keypad buttons to scroll to the correct date.
- **EQUIPMENT:** Always set to CONV even if the unit is a heat pump.
- **AUX2 IN:** Always set to W1.
- **FAN TYPE:** Set for either single or 2 speed. The default is 2 speed.
- **AUX1 OUT:** If remote Fault Detection and Diagnostic (FDD) monitoring is required select SYS. – OCC: occupancy, always set to INPUT

SETPOINTS

- **MAT SET:** this sets the mixed air temperature (MAT) setting. The controller has a default of 53 degrees, but the range is anywhere from 38 to 70 degrees F.
- **LOW T LOCK:** This setting locks out the compressor (or mechanical cooling) at a given temperature. The default is 32 degrees F, but the controller's range is from -45 to 80 degrees F.
- **DRYBULB SET:** if you have an economizer with a dry bulb outside air sensor you will see and set the DRYBULB SET. The default setting is 63 degrees F, but the controller's range is 48 to 80 degrees F.
- **ENTH CURVE:** if you have a single enthalpy outside air sensor instead of a dry bulb, you will see and set the ENTH CURVE setting. There are 5 setting options: ES1 thru ES5. Check the economizer literature for the limits for each of these settings. ES3 is the default setting.
- **MIN POS:** The minimum position allows for ventilation even when not in the free-cooling mode. If you have a single speed unit there will be only one minimum position setting. The default is 2.8 volts, but the range is 2-10Vdc.
 - **MIN POS H and MIN POS L:** If your unit is 2 speed, there will be 2 minimum position settings that show up on the menu. The first is MIN POS H (for high speed) which has a default of 2.8 volts. The second is MIN POS L (for low speed), which has a default of 3.2. Note that MIN POS H and MIN POS L are only displayed if under SYSTEM SETUP: AUX2 IN is set to "W1", and FAN TYPE is set to 2 speed.

Table 10 - Standard Jade W7220 Controller Configuration

		FOR SINGLE SPEED UNIT		FOR 2 SPEED UNITS		
Controller Menu Item		Default	Set To:	Default	Set To:	Note
SETPOINTS	MAT SET	53°F	38° to 70°F	53°F	38° to 70°F	
	LOW T LOCK	32°F	-45° to 80°F	32°F	-45° to 80°F	
	DRYBLB SET	63°F	48° to 80°F	63°F	48° to 80°F	Only displayed if using single DB OA sensor
	ENTH CURVE	ES3	ES1 to ES5	ES3	ES1 to ES5	Only displayed if using a single enthalpy OA sensor
	MIN POS	2.8 Vdc	2 to 10 Vdc	NA		Only displayed if set up for single speed unit
	MIN POS H	NA	NA	2.8 Vdc	2 to 10 Vdc	Only displayed if set up for 2 speed unit
	MIN POS L	NA	NA	3.2 Vdc	2 to 10 Vdc	Only displayed if set up for 2 speed unit
SYSTEM SETUP	INSTALL	1/1/2010	Current date	1/1/2010	Current date	
	EQUIPMENT	CONV	CONV	CONV	CONV	Always set to CONV, even on HP units
	AUX2 I	W1*	W1	W1*	W1	Always set to W1
	FAN TYPE	2 speed*	1 speed	2 speed*	2 speed	Default may vary on some models
	AUX1 OUT	NONE	SYS	NONE	SYS	Set to SYS for remote FDD monitoring
	OCC	INPUT	INPUT	INPUT	INPUT	Always set to INPUT

Note 1: For 2 speed unit, under SYSTEM SETUP: EQUIPMENT= CONV, AUX2 I = W1, and FAN TYPE = 2 SPEED

Note 2: More sophisticated controller setups, including for DCV or power exhaust, are available by referring to Table 11 options

NA = Not applicable

*Available on Firmware 1.15 June 2018 and later



MicroMetl

Table 11 – Menu Structure*

Menu	Parameter	Parameter Default Value	Parameter Range and Increment ^b	Notes
STATUS	ECON AVAIL	NO	YES/NO	ECONOMIZING AVAILABLE YES = economizing available; the system can use outside air for free cooling when required
	ECONOMIZING	NO	YES/NO	ECONOMIZING ACTIVE YES = Outside air being used for 1st stage cooling. NO = Economizing not active
	OCCUPIED	NO	YES/NO	OCCUPIED YES = OCC signal received from space thermostat or unitary controller. YES = 24 Vac on terminal OCC. NO = 0 Vac on terminal OCC
	HEAT PUMP	n/a ^c	COOL HEAT	HEAT PUMP MODE (Not available on 2-Speed configuration)
	COOL Y1-IN	OFF	ON/OFF	FIRST STAGE COOLING DEMAND (Y1---IN) Y1-I signal from space thermostat or unitary controller for Cooling Stage 1. ON = 24 Vac on terminal Y1-I OFF = 0 Vac on terminal Y1-I
	COOL Y1-OUT	OFF	ON/OFF	FIRST STAGE COOLING RELAY OUTPUT ON = 24 Vac on terminal Y1-O; Stage 1 mechanical cooling called on OFF = 0 Vac on terminal Y1-O; no mechanical cooling
	COOL Y2-IN	OFF	ON/OFF	SECOND STAGE COOLING DEMAND (Y2---IN) Y2-I signal from space thermostat or unitary controller for Cooling Stage 2. ON = 24 Vac on terminal Y2-I OFF = 0 Vac on terminal Y2-I
	COOL Y2-OUT	OFF	ON/OFF	SECOND STAGE COOLING RELAY OUTPUT ON = 24 Vac on terminal Y2-O; Stage 2 mechanical cooling called on OFF = 0 Vac on terminal Y2-O; no Stage 2 mechanical cooling
	MA TEMP	nn°F (or °C)	0 to 140°F (-18 to 60°C)	MIXED AIR TEMPERATURE, Cooling Mode Displays value of measured mixed/cooled air from MAT sensor in fan section. Displays --- if not connected, short or out-of-range.
	DA TEMP	nn°F (or °C)	0 to 140°F (-18 to 60°C)	DISCHARGE AIR TEMPERATURE, after Heating section (Accessory sensor required) Displays when Discharge Air sensor is connected and displays measured discharge temperature. Displays ----- if sensor sends invalid value, if not connected, short or out-of-range.
	OA TEMP	nn°F (or °C)	-40 to 140°F (-40 to 60°C)	OUTSIDE AIR TEMPERATURE Displays measured value of outdoor air temperature. Displays ----- if sensor sends invalid value, if not connected, short or out-of-range.
	OA HUM	nn%	0 to 100%	OUTSIDE AIR RELATIVE HUMIDITY Displays measured value of outdoor humidity from accessory OA enthalpy sensor.
	RA TEMP	nn°F (or °C)	0 to 140°F (-18 to 60°C)	RETURN AIR TEMPERATURE (Accessory sensor required) Displays measured value of return air temperature from return air sensor.
	RA HUM	nn%	0 to 100%	RETURN AIR RELATIVE HUMIDITY (Accessory enthalpy sensor required) Displays measured value of return air humidity from return air sensor.
	IN CO2	___ppm	0 to 2000 ppm	SPACE/RETURN AIR CO2 (CO2 sensor required, accessory or factory option) Displays value of measured CO2 from CO2 sensor. Invalid if not connected, short or out-of-range
	DCV STATUS	n/a	ON/OFF	DEMAND CONTROL VENTILATION STATUS (CO2 sensor required, accessory or factory option) Displays ON if IN CO2 value above setpoint DCV SET and OFF if below setpoint DCV SET.
	DAMPER OUT	2.0V	2.0 to 10.0V	Displays voltage output to the damper actuator. 0% = OA Damper fully closed 100% = OA Damper full open
	ACT POS	nn%	0 to 100%	Displays actual position of outdoor air damper actuator 2.0V = OA Damper fully-closed 10.0V = OA Damper full open
	ACT COUNT	n/a	1 to 65535	Displays number of times actuator has cycled. 1 Cycle equals accrued 180° of actuator movement in any direction
	ACTUATOR	n/a	OK/Alarm (on Alarm menu)	Displays Error if voltage or torque is below actuator range
EXH1 OUT	OFF	ON/OFF	EXHAUST STAGE 1 RELAY OUTPUT Output of EXH1 terminal: ON = relay closed OFF = relay open	

* Table 11 illustrates the complete hierarchy. your menu parameters may be different depending on your configuration.



MicroMetl

Table 11 – Menu Structure (cont)*

Menu	Parameter	Parameter Default Value	Parameter Range and Increment ^b	Notes
STATUS (cont)	EXH2 OUT	OFF	ON/OFF	EXHAUST STAGE 2 RELAY OUTPUT Output of AUX terminal; displays only if AUX = EXH2 ON = relay closed OFF = relay open
	ERV	OFF	ON/OFF	ENERGY RECOVERY UNIT RELAY OUTPUT Output of AUX terminal; displays only if AUX = ERV ON = relay closed OFF = relay open
	MECH COOL ON	0	0, 1, or 2	Displays stage of mechanical cooling that is active.
	FAN SPEED	n/a	LOW or HIGH	SUPPLY FAN SPEED Displays speed setting of fan on a 2-speed fan unit.
	W (HEAT ON)	n/a	ON/OFF	HEAT DEMAND STATUS Displays status of heat demand on a 2-speed fan unit.
SETPOINTS	MAT SET	53°F (12°C)	38° to 70°F; (3° to 18°C) increment by 1	MIXED AIR SETPOINT Setpoint determines where the economizer will modulate the OA damper to maintain the mixed air temperature.
	LOW T LOCK	32°F (0°C)	-45° to 80°F; (-43° to 27°C) increment by 1	COMPRESSOR LOW TEMPERATURE LOCKOUT Setpoint determines outdoor temperature when the mechanical cooling cannot be turned on.
	DRYBLB SET	63°F (17°C)	48° to 80°F (9° to 27°C) increment by 1	OA DRY BULB TEMPERATURE CHANGEOVER SETPOINT Setpoint determines where the economizer will assume outdoor air temperature is good for free cooling; e.g.: at 63°F (17°C), unit will economize at 62°F (16.7°C) and below and not economize at 64°F (17.8°C) and above. There is a 2°F (1.1°C) deadband. DRYBULB SET is only displayed if the economizer has a single dry bulb sensor
	DRYBLB DIF (Available firmware 1.15, June 2018 and later)	0°F	0 to 6°F Increment by 2	Drybulb Differential will only show if using dual drybulb, i.e., when an outdoor air temperature sensor C7250 is attached to OAT terminals, and a C7400S enthalpy sensor is wired to S-Bus and configured for RAT (return air). Free cooling will be assumed whenever OA temp is at or below RAT minus this drybulb differential setting.
	ENTH CURVE	ES3	ES1, ES2, ES3, ES4, or ES5	ENTHALPY CHANGEOVER CURVE (Requires enthalpy sensor option) Enthalpy boundary "curves" for economizing using single enthalpy.
	DCV SET	1100ppm	500 to 2000 ppm; increment by 100	DEMAND CONTROL VENTILATION SETPOINT Displays only if CO2 sensor is connected. Setpoint for Demand Control Ventilation of space. Above the setpoint, the OA dampers will modulate open to bring in additional OA to maintain a space ppm level below the setpoint.
	MIN POS	2.8 V	2 to 10 Vdc	VENTILATION MINIMUM POSITION. Only displayed if controller is set for single speed unit under FAN TYPE, and if DCV is NOT used.
	MIN POS L	3.2 V	2 to 10 Vdc	VENTILATION MINIMUM POSITION AT LOW SPEED Displays ONLY if used on 2 speed units and CO2 sensor is NOT used.
	MIN POS H	2.8 V	2 to 10 Vdc	VENTILATION MINIMUM POSITION AT HIGH SPEED Displays ONLY if used on 2 speed units and CO2 sensor is NOT used.
	VENTMAX L	2.8 V	2 to 10 Vdc	DCV MAXIMUM DAMPER POSITION AT LOW SPEED (Requires CO2 sensor connected)
	VENTMAX H	4.4 V	2 to 10 Vdc	DCV MAXIMUM DAMPER POSITION AT HIGH SPEED (Requires CO2 sensor connected)
	VENTMIN L	2.25 V	2 to 10 Vdc	DCV MINIMUM DAMPER POSITION AT LOW SPEED (Requires CO2 sensor connected)
	VENTMIN H	2.8 V	2 to 10 Vdc	DCV MINIMUM DAMPER POSITION AT HIGH SPEED (Requires CO2 sensor connected)
	ERV OAT SP	32°F (0°C)	0° to 50°F; (-18° to 10°C) increment by 1	ENERGY RECOVERY VENTILATION UNIT OUTDOOR AIR TEMPERATURE SETPOINT Only displayed when AUX1 O = ERV
	EXH1 SET	50%	0 to 100%	Exhaust fan set point for single speed units. Based on OA Damper position to activate power exhaust.
	EXH1 L SET	65%	0 to 100%; Increment by 1	EXHAUST FAN SETPOINT AT LOW SPEED (on 2 speed unit) Setpoint for OA damper position when exhaust fan is powered by the economizer
	EXH1 H SET	50%	0 to 100%; Increment by 1	EXHAUST FAN SETPOINT AT HIGH SPEED (on 2 speed unit) Setpoint for OA damper position when exhaust fan is powered by the economizer
	EXH2 L SET	80%	0 to 100%; Increment by 1	EXHAUST FAN STAGE 2 SETPOINT AT LOW SPEED Setpoint for OA damper position when exhaust fan 1 is powered by the economizer. Only used when AUX1-O is set to EHX2. Note: Standard power exhaust kits have only 1 speed, therefore EXH2 is not applicable
	EXH2 H SET	75%	0 to 100%; Increment by 1	EXHAUST FAN STAGE 2 SETPOINT AT HIGH SPEED Setpoint for OA damper position when exhaust fan 1 is powered by the economizer. Only used when AUX1-O is set to EHX2. Note: Standard power exhaust kits have only 1 speed, therefore EXH2 is not applicable

Note: MIN POS defaults may vary on some models.

* Table 11 illustrates the complete hierarchy. your menu parameters may be different depending on your configuration.



MicroMetl

Table 11 – Menu Structure (cont)*

Menu	Parameter	Parameter Default Value	Parameter Range and Increment ^b	Notes
SYSTEM SETUP	INSTALL	01/01/10		Display order = MM/DD/YY Setting order = DD, MM, then YY.
	UNITS DEG	°F	°F or °C	Sets economizer controller in degrees Fahrenheit or Celsius.
	EQUIPMENT	CONV	Conventional or HP	Always set to CONV even for heat pump
	AUX2 I	W1	Always set to W1	Always set to W1
	FAN TYPE	2 speed	1 speed / 2 speed	Sets the economizer controller for operation of 1 speed or 2 speed indoor fan system. Note: Default settings may vary.
	FAN CFM	5000cfm	100 to 15000 cfm; increment by 100	UNIT DESIGN AIRFLOW (CFM) Enter ONLY if using DCVCAL ENA = AUTO
	AUX1 OUT	NONE	NONE ERV EXH2 SYS	Select OUTPUT for AUX1 O relay NONE = not configured (output is not used) ERV = Energy Recovery Ventilator ^d EXH2 = second damper position relay closure for second exhaust fan SYS = use output as an FDD remote alarm signal
	OCC	INPUT	INPUT or ALWAYS	Always set to INPUT
	FACTORY DEFAULT	NO	NO or YES	Resets all set points to factory defaults when set to YES. LCD will briefly flash YES and change to NO but all parameters will change to factory default values.
ADVANCED SETUP	MA LO SET	45°F (7°C)	35° to 55°F; (2° to 12°C) Incremented by 1°	MIXED AIR TEMPERATURE LOW LIMIT Temperature to achieve Freeze Protection (close damper and alarm if temperature falls below setup value)
	FREEZE POS	CLO	CLO or MIN	FREEZE PROTECTION DAMPER POSITION Damper position when freeze protection is active CLO = closed MIN = MIN POS or VENTMIN
	CO2 ZERO	0ppm	0 to 500 ppm: Increment by 10	CO2 ppm level to match CO2 sensor start level.
	CO2 SPAN	2000ppm	1000 to 3000 ppm; Increment by 50	CO2 ppm span to match CO2 sensor.
	STG3 DLY	2.0h	0 min, 5 min, 15 min, then 15 min intervals. Up to 4 h or OFF	COOLING STAGE 3 DELAY Delay after stage 2 for cool has been active. Turns on 2nd stage of cooling when economizer is 1st stage and mechanical cooling is 2nd
	SD DMPR POS	CLO	CLO or OPEN	Function NOT AVAILABLE with 2-speed mode
	DCVCAL ENA	MAN	manual or auto	Turns on the DCV automatic control of the dampers. Resets ventilation. For single speed units only.
	MATTCAL	0.0°F (or C)	+/- ---2.5°F (+/- ---1.4°C)	MIXED AIR TEMPERATURE CALIBRATION Allows for the operator to adjust for an out of calibration mixed air temperature (MAT) sensor
	OAT CAL	0.0°F (or C)	+/- ---2.5°F (+/- ---1.4°C)	OUTSIDE AIR TEMPERATURE CALIBRATION Allows for the operator to adjust for an out of calibration outside air temperature (OAT) sensor
	OAH CAL	0% RH	+/- ---10% RH	OUTSIDE AIR HUMIDITY CALIBRATION Allows for the operator to adjust for an out of calibration outside air enthalpy sensor
	RAT CAL	0.0°F (or C)	+/- ---2.5°F (+/- ---1.4°C)	RETURN AIR TEMPERATURE CALIBRATION Allows for the operator to adjust for an out of calibration return air temperature (RA) sensor
	RAH CAL	0% RH	+/- ---10% RH	RETURN AIR HUMIDITY CALIBRATION Allows for the operator to adjust for an out of calibration return air enthalpy sensor
	DAT CAL	0.0°F (or C)	+/- ---2.5°F (+/- ---1.4°C)	DISCHARGE AIR TEMPERATURE CALIBRATION Allows for the operator to adjust for an out of calibration discharge air temperature (DAT) sensor
2SP FAN DELAY	5 Minutes	0 to 20 minutes in 1 minute increments	TIME DELAY ON 2nd STAGE ECONOMIZING While in the Economizing mode, this is the delay between thermostat Y2 call and Y1---O output to mechanical cooling stage, to allow high speed fan operation to attempt to cool space first.	

* Table 11 illustrates the complete hierarchy. your menu parameters may be different depending on your configuration.



MicroMetl

Table 11 – Menu Structure (cont)*

Menu	Parameter	Parameter Default Value	Parameter Range and Increment	Notes
CHECKOUT	DAMPER VMIN .HS	n/a	n/a	Positions OA damper to VMIN High Speed position
	DAMPER VMAX .HS	n/a	n/a	Positions OA damper to VMAX High Speed position
	DAMPER OPEN	n/a	n/a	Positions OA damper to the full open position.
	DAMPER CLOSE	n/a	n/a	Positions damper to the fully closed position
	CONNECT Y1---O	n/a	n/a	Closes the Y1---O relay (Y1---O)
	CONNECT Y2---O	n/a	n/a	Closes the Y2---O relay (Y2---O)
	CONNECT AUX1O	n/a	n/a	Energizes the AUX1O output. If Aux setting is: <ul style="list-style-type: none"> • NONE --- not action taken • ERV --- 24 Vac out. Turns on or signals an ERV that the conditions are not good for economizing but are good for ERV operation.^d • SYS – 24 Vac out. Issues a system alarm
ALARMS(_)				Alarms display only when they are active. The menu title “ALARMS(_)” includes the number of active alarms in parenthesis ().
	MA T SENS ERR	n/a	n/a	MIXED AIR TEMPERATURE SENSOR ERROR
	CO2 SENS ERR	n/a	n/a	CO2 SENSOR ERROR
	OA T SENS ERR	n/a	n/a	OUTSIDE AIR TEMPERATURE SENSOR ERROR OAT sensor connected at input terminals OAT
	OA SYLK SENS ERR	n/a	n/a	OUTSIDE AIR ENTHALPY SENSOR ERROR OAT sensor connected on S- bus
	DA T SENS ERR	n/a	n/a	DISCHARGE AIR TEMPERATURE SENSOR ERROR
	SYS ALARM	n/a	n/a	When AUX1-0 is set to SYS and there is any alarm (e.g., failed sensors, etc.), the AUX1-0 terminal provides 24 Vac out.
	ACT UNDER V	n/a	n/a	ACTUATOR VOLTAGE LOW Voltage received at actuator is below expected range
	ACT OVER V	n/a	n/a	ACTUATOR VOLTAGE HIGH Voltage received at actuator is above expected range
	ACT STALLED	n/a	n/a	ACTUATOR STALLED Actuator stopped before reaching commanded position

*Table 11 illustrates the complete hierarchy. your menu parameters may be different depending on your configuration.

CHECKOUT TESTS

Use the Checkout menu (see Table 11) to test the damper operation and any configured outputs. Only items that are configured are shown in the Checkout menu.

NOTE: See User Interface for information about menu navigation and use of the keypad.

To perform a Checkout test:

1. Scroll to the desired test in the Checkout menu using the ▲ and ▼ buttons.
2. Press the ↵ button to select the item.
3. RUN? appears.
4. Press the ↵ button to start the test.
5. The unit pauses and then displays IN PROGRESS.
6. When the test is complete, DONE appears.
7. When all desired parameters have been tested, press the ⬆ (Menu up) button to end the test.

Checkout test can be performed at any time during the operation of the system as a test that the system is operable.

LEGEND

- LCD – Liquid Crystal Display
- MAT – Mixed Air Temperature
- OAT – Outdoor Air Temperature
- OCC – Occupied
- RAT – Return Air Temperature
- RTU – Rooftop Unit



CAUTION

EQUIPMENT DAMAGE HAZARD

Failure to follow this caution may result in damage to equipment. Be sure to allow enough time for compressor startup and shutdown between checkout tests so that you do not short-cycle the compressors.



MicroMetl

W7220 ECONOMIZER MODULE WIRING

Use tables 12 and 13 to locate the wiring terminals for the Economizer module.

**Table 12 - Economizer Module -
Left Hand Terminal Blocks**

Label	Type	Description
Top Left Terminal Block		
MAT MAT	20k NTC and COM	Mixed Air Temperature Sensor (Polarity insensitive connections)
OAT OAT	20k NTC and COM	Outdoor Air Temperature Sensor (Polarity insensitive connection)
S-BUS S-BUS	S-BUS (Sylk Bus)	Enthalpy Control Sensor (Polarity insensitive connection)
Bottom Left Terminal Block		
IAQ 2-10	2-10 Vdc	Air Quality Sensor Input (e.g. CO ₂ sensor)
IAQ COM	COM	Air Quality Sensor Common
IAQ 24V	24 Vac	Air Quality Sensor 24 Vac Source
ACT 2-10	2-10 Vdc	Damper Actuator Output (2-10 Vdc)
ACT COM	COM	Damper Actuator Output Common
ACT 24V	24 Vac	Damper Actuator 24 Vac Source

**Table 13 - Economizer Module -
Right Hand Terminal Blocks**

Label	Type	Description
Top Right Terminal Block		
	n/a	The first terminal is not used
AUX2 I	24 Vac IN	Shut Down (SD) or Heat (W) Conventional only and Heat Pump Changeover (O/B) in Heat Pump mode.
OCC	24 Vac IN	Occupied / Unoccupied Input
E - GND	E-GND	Earth Ground - System Required
EXH1	24 Vac OUT	Exhaust Fan 1 Output
AUX1 O	24 Vac OUT	Programmable: Exhaust fan 2 output or ERV or System alarm output
Bottom Right Terminal Block		
Y2-1	24 Vac IN	Y2 in - Cooling Stage 2 Input from space thermostat
Y2-O	24 Vac OUT	Y2 out - Cooling Stage 2 Output to stage 2 mechanical cooling
Y1-I	24 Vac IN	Y1 in - Cooling Stage 2 Input from space thermostat
Y1-O	24 Vac OUT	Y1 out - Cooling Stage 2 Output to stage 2 mechanical cooling
C	COM	24 Vac Common
R	24 Vac	24 Vac Power (Hot)

Time-out and Screen Saver

When no buttons have been pressed for 10 minutes, the LCD displays a screen saver, which cycles through the Status items. Each Status item displays in turn and cycles to the next item after 5 seconds.



MicroMetl

START-UP AND OPERATION

Cooling with Economizer — For Occupied mode operation of economizer, there must be a 24-v signal at terminals R and OCC (provided through PL6-3 from the unit's IFC coil). Removing the signal at OCC places the economizer control in Unoccupied mode. See Table 14 for Damper Position Control.

During Occupied mode operation, indoor fan operation will be accompanied by economizer dampers moving to Minimum Position setpoint for ventilation. If indoor fan is off, dampers will close. During Unoccupied mode operation, dampers will remain closed unless a Cooling (by free cooling) or DCV demand is received.

When free cooling using outside air is not available, the unit cooling sequence will be controlled directly by the space thermostat. Outside air damper position will be closed or Minimum Position as determined by Occupancy mode and fan signal.

When free cooling is available as determined by the appropriate changeover command (dry bulb, outdoor enthalpy, differential dry bulb or differential enthalpy), a call for cooling (Y1 closes at the thermostat) will cause the economizer control to modulate the dampers open and closed to maintain the unit mixed air temperature. Default mixed air temperature is 53°F, with a range of 38°F to 70°F. Compressor will not run.

Should 100% outside air not be capable of satisfying the space temperature, space temperature will rise until Y2 is called for. The economizer control will call for compressor operation. Dampers will modulate to maintain MAT at set point concurrent with Compressor 1 operation. The "Low T Lock" setting (default 32°F) will lock out compressor operation when outside air temperature is below setpoint.

When space temperature demand is satisfied (thermostat Y1 opens), the dampers will return to Minimum Damper position if indoor fan is running or fully closed if fan is off.

If accessory power exhaust is installed, the power exhaust fan motors will be energized by the economizer control as the dampers open above the EXH1 SET setpoint and will be de-energized as the dampers close below the EXH1 SET setpoint. (For single speed unit.)

Damper movement from full closed to full open (or vice versa) will take between 1 1/2 and 2 1/2 minutes.

Heating with Economizer — During Occupied mode operation, indoor fan operation will be accompanied by economizer dampers moving to Minimum Position setpoint for ventilation. If indoor fan is off, dampers will close. During Unoccupied mode operation, dampers will remain closed unless a DCV demand is received.

When the room temperature calls for heat (W1 closes), the heating controls are energized.

Table 14 - Damper Position Control, 2-Speed Fan Motor, Economizer Cooling Not Available

INPUT		VOLTAGE			
OCC	0 - V	24 - V	24 - V	24 - V	24 - V
Y1	0 - V	0 - V	24 - V	24 - V	0 - V
Y2	0 - V	0 - V	0 - V	24 - V	0 - V
W1	0 - V	0 - V	0 - V	0 - V	24 - V
SUPPLY FAN MOTOR SPEED					
SUPPLY FAN MOTOR SPEED	OFF	LOW	LOW	HIGH	HIGH
DAMPER POSITION		DAMPER POSITION			
NO CO2 SENSOR	CLOSED	MIN POS-L	MIN POS-L	MIN POS-H	MIN POS-H
W/ CO2 SENSOR	CLOSED	FROM VENTMIN L TO VENTMAX L	FROM VENTMIN L TO VENTMAX L	FROM VENTMIN H TO VENTMAX H	FROM VENTMIN H TO VENTMAX H



MicroMetl

TROUBLESHOOTING

For a list of common operating issues and concerns see Table 15.

Power Loss (Outage or Brownout) — All setpoints and advanced settings are restored after any power loss or interruption, as all settings are stored in the economizer controller's non-volatile flash memory.

NOTE: If power goes below 18 Vac, the W7220 module assumes a power loss and the 5-minute power up delay will become functional when power returns above 18 vac.

Alarms — The economizer module provides alarm messages that display on the 2-line LCD.

NOTE: Upon power up, the module waits several seconds before checking for alarms. This allows time for all the configured devices (e.g. sensors, actuator) to become operational.

If one or more alarms are present and there has been no keypad activity for at least 5 minutes, the Alarms menu displays and cycles through the active alarms.

The Alarms menus can be navigated at any time. See Table 11 for the Alarms menu.

Clearing Alarms — Once the alarm has been identified and the cause has been removed (e.g. replaced faulty sensor). They can be cleared from the display.

To clear an alarm, perform the following:

1. Navigate to the desired alarm.
2. Press the button.
3. ERASE? displays.
4. Press the button.
5. ALARM ERASED displays.
6. Press the ⬆ (Menu Up/Exit) button to complete the action and return to the previous menu.

NOTE: If the alarm still exists after you clear it, it is redisplayed within 5 seconds.

Table 15 - Operating Issues and Concerns

Issue or Concern	Possible Cause and Remedy
My outdoor temperature reading on the STATUS menu is not accurate	Check the sensor wiring: <ul style="list-style-type: none"> • Enthalpy sensors are to be wired to the S-Bus terminals. • Temperature sensors are to be wired to the OAT and MAT terminals.
If my enthalpy sensor drifts in accuracy over time, can I re-calibrate it?	The sensor is not able to be re-calibrated in the field. However there is a menu item under the ADVANCED menu where you are able to input a limited off set in temperature and humidity for each sensor you have connected to the economizer.
Can I go back to factory defaults and start over?	Under the SYSTEM SETUP menu you can change the setpoints to the factory defaults.
Will I be able to see the LCD screen when it is in the unit?	The LCD screen has a backlight that is always illuminated.
What is a good setpoint for the Mixed Air Temperature (MAT)?	The mixed air temperature is the temperature of air that you want to supply to the space. In a commercial building, this is between 50 to 55°F (10 to 13°C). The mixed air is the mixing of the return air and the outdoor air.
I am using enthalpy sensors. Why did the control ask me to input a dry bulb changeover temperature?	In the event the humidity sensor in the enthalpy sensors fails, the backup algorithm in the control is to default to the temperature sensor in the enthalpy sensor.
In checkout, the outdoor damper closes when I command it to open.	Check the actuator linkage or rotation. In the CHECKOUT mode, the outdoor damper should drive open or closed with the return air damper having the opposite effect.
How do I set my minimum position when using a CO2 sensor?	The minimum position is set using the VENTMIN and VENTMAX setup in the SETPOINTS menu. VENTMIN is the minimum ventilation required when using an occupancy sensor and VENTMAX is the minimum ventilation when not using an occupancy sensor for Demand Control Ventilation. The VENTMAX position is set the same as with the potentiometer on the analog economizers and is the output voltage to the damper actuator. The range is 2 Vdc closed OA damper and 10 Vdc open OA damper.
What if my damper does not go completely closed in the checkout operation?	Check the damper linkage or hub to make sure the damper is able to close completely.
Does the economizer save my program values if the unit loses power?	Yes, once the changes are stored in the controller they will be stored until they are changed by the operator.
If the unit is left in checkout, how long will the unit stay in checkout mode without input?	The unit will remain in checkout for 10 minutes, then return to normal operation.

MicroMetl Indianapolis
3035 N. Shadeland Ave.,
Suite 300 Indianapolis, IN 46226

MicroMetl Longview
201 Kodak Blvd.
Longview, Texas 75602

MicroMetl Sparks
905 Southern Way
Sparks, Nevada 89431