



**Humidifier**  
**Integrated and Wall Mounted**  
**Wine Cellar Cooling Systems**  
**Installation, Operation and Maintenance Manual**  
**60Hz and 50Hz Models**



**Manufactured by**



AIR INNOVATIONS

Syracuse, NY

[wineguardian.com](http://wineguardian.com)

[airinnovations.com](http://airinnovations.com)

Wine Guardian reserves the right, without notice, to make changes to this document at its sole discretion.

Please visit our web site for the most current version of the Wine Guardian manual and other literature.

Wine Guardian is a registered trademark (2,972,262) of Air Innovations, Inc.

Edition 3/2022 (Original Instructions)

© Air Innovations 2022

Part No. 15H0164-00

# Table of Contents

<b>Safety</b> .....	4
<b>Lockout/Tagout Procedure</b> .....	5
<b>Safety Warnings</b> .....	5
<b>Receiving, Inspecting and Unpacking</b> .....	5
<b>Directory of terms</b> .....	7
<b>General Overview</b> .....	7
<b>Wiring Diagram – Integrated Humidifier (60Hz / 50Hz)</b> .....	9
<b>Wiring Diagram – Freestanding Humidifier (60Hz)</b> .....	10
<b>Wiring Diagram – Freestanding Humidifier (50Hz)</b> .....	11
<b>Humidifier Dimensions (Freestanding)</b> .....	12
<b>Humidifier Dimensions (Integrated)</b> .....	13
<b>Installation</b> .....	14
<b>Pre-Installation</b> .....	14
<b>Freestanding Installation</b> .....	15
<b>Integrated Installation (Sentinel)</b> .....	17
<b>Integrated Installation (Legacy D050 &amp; D088)</b> .....	18
<b>Integrated Installation (Legacy D200)</b> .....	20
<b>Start-Up</b> .....	23
<b>Mounting the Humidistat</b> .....	25
<b>Maintenance</b> .....	26
<b>Suggested Maintenance Schedule</b> .....	26
<b>Replacing the Drip Pad</b> .....	27
<b>Water Line Maintenance</b> .....	28
<b>Contact and Warranty</b> .....	29

**Note:** This equipment has been tested and found to comply with the limits for a Class B digital device, pursuant to part 15 of the FCC Rules. These limits are designed to provide reasonable protection against harmful interference in a residential installation. This equipment generates, uses and can radiate radio frequency energy and, if not installed and used in accordance with the instructions, may cause harmful interference to radio communications. However, there is no guarantee that interference will not occur in a particular installation. If this equipment does cause harmful interference to radio or television reception, which can be determined by turning the equipment off and on, the user is encouraged to try to correct the interference by one or more of the following measures:

- Reorient or relocate the receiving antenna.
- Increase the separation between the equipment and receiver.
- Connect the equipment into an outlet on a circuit different from that to which the receiver is connected.
- Consult the dealer or an experienced radio/TV technician for help. RSS GEN (English)

This device contains license-exempt transmitter(s)/receiver(s) that comply with Innovation, Science and Economic Development Canada's license-exempt

RSS(s). Operation is subject to the following two conditions:

1. This device may not cause interference.
2. This device must accept any interference, including interference that may cause undesired operation of the device.

RSS GEN (French)

L'émetteur/récepteur exempt de licence contenu dans le présent appareil est conforme aux CNR d'Innovation, Sciences et Développement économique Canada applicables aux appareils radio exempts de licence. L'exploitation est autorisée aux deux conditions suivantes:

1. L'appareil ne doit pas produire de brouillage;
2. L'appareil doit accepter tout brouillage radioélectrique subi, même si le brouillage est susceptible d'en compromettre le fonctionnement.

## **Safety**

The safety messages contained in this manual are bold and highlighted in red for quick identification. A Danger message indicates an imminently hazardous situation which, if not avoided, can result in death or serious injury. Messages identified by the word DANGER are used sparingly and only for those situations presenting the most serious hazards. The following is a typical example of a Danger message as it could appear in the manual.



### **HIGH VOLTAGE - RISK OF SERIOUS INJURY OR DEATH**

**High voltages are present in the cabinets.**

**Before opening panels turn off all power.**

**Use the Lockout/Tagout procedure.**

The equipment covered by this manual is designed for safe and reliable operation when installed and operated within its designed specifications. To avoid personal injury or damage to equipment or property when installing or operating this equipment, it is essential that qualified, experienced personnel perform these functions, using good judgment and safe practices. See the following cautionary statements. Installation and maintenance of this equipment is to be performed only by qualified personnel who are familiar with local codes and regulations and are experienced with this type of equipment.

Exposure to safety hazards is limited to maintenance personnel working in and around the unit. When performing maintenance, always use the Lockout/Tagout procedure, which is described in this chapter. Observe the maintenance safety guidelines in the Wine Guardian Manual.

**Electrical Hazards** - Working on the equipment may involve exposure to dangerously high voltage. Make sure you are aware of the level of electrical hazard when working on the system. Observe all electrical warning labels on the unit. There are no electrical safety lockouts installed within the unit. The power cord attached to the control box must be disconnected from the power sources prior to working on any part of the electrical system.

**Moving Parts Hazards** - The motor and blower must be disconnected prior to opening access panels. The motor can start automatically. Disconnect all power and control circuits prior to servicing to avoid serious injuries or possible dismemberment. Be sure to use the Lockout/Tagout procedure when working on these units.

## **Lockout/Tagout Procedure**

1. Unplug the unit from the electrical outlet and cover the outlet to prevent accidentally plugging in the unit. (Freestanding, Self-Powered)
2. Unplug the unit from the Wine Guardian Unit to prevent the humidifier from running (Integrated)

## **Safety Warnings**

- Never reach into a unit while the fan is running.
- Disconnect all power sources before working on the unit.
- Cut-off water to the unit when being serviced.
- Always ground the outlet to provide adequate protection against voltage surges and built-up static charges.
- Refer all servicing to qualified service personnel. Servicing is required when the unit has been damaged in any way.
- Do not use extension cords.
- Do not modify the equipment, it may cause damage to the equipment and will void the warranty.

## **Receiving, Inspecting and Unpacking**

When receiving the unit, ensure the unit is undamaged and includes all ordered accessories.

**Note:** Wine Guardian units are factory assembled and tested prior to shipment.

Wine Guardian units are shipped in individual corrugated boxes.

- ✓ Lift only at the designated handhold locations or fully support from underneath. A shipment may include one or more boxes containing accessories.
- ✓ Before opening the container, inspect the packing crates or boxes for obvious signs of damage or mishandling.
- ✓ Write any discrepancy or visual damage on the bill of lading before signing.
- ✓ Inspect all equipment for any signs of damage caused during transit.
- ✓ Report all visual or concealed damage to the carrier and file a claim immediately.
- ✓ Thoroughly inspect the contents for any visible damage or loose parts.

### **IMPORTANT**

If this procedure is not followed, the shipping company may reject the claim and the consignee may suffer the loss. Do not return the shipment to the factory

Review the Packing Slip to verify:

- ✓ Model #
- ✓ Factory Installed Options
- ✓ Unit Accessories

If any items listed on the packing slip do not match your order information, contact the place of purchase immediately.

This Wine Guardian Humidifier is shipped in a cardboard box. Each humidifier is factory assembled and tested prior to shipment. There are three models of the Wine Guardian humidifier. See 50 & 60Hz part numbers in the table below.

- Freestanding humidifier supplied with its own grille. This freestanding humidifier is to be used in a wine room with a Wine Guardian system.
- Freestanding humidifier supplied with its own grille, power cord and humidistat. This freestanding humidifier is to be used in a wine room without a Wine Guardian system.
- Integrated humidifier that mounts directly to the side of any ducted or split Wine Guardian system. Humidifier is controlled by the Remote Interface Controller via communication cable.

<b>60 Hz Part #</b>	<b>50 Hz Part #</b>	<b>Description</b>
99H0174-21	99H0176-20	Freestanding humidifier supplied with its own grille, and Mounting Bracket. Used with a Wine Guardian unit.
99H0185-21	N/A	Freestanding humidifier supplied with its own grille, Mounting Bracket, power cord, and humidistat. Used without a Wine Guardian unit.
99H0173-20	99H0175-20	Integrated humidifier that mounts directly to the side of <i>Chassis A</i> ducted Wine Guardian system.
99H0173-21	99H0175-21	Integrated humidifier that mounts directly to the side of <i>Legacy 050/088s</i> self-contained and split Wine Guardian systems.
99H0173-22	99H0188-20	Integrated humidifier that mounts directly to the side of <i>Legacy 200</i> ducted self-contained and split Wine Guardian systems.

## Directory of terms

- **Ambient Air** – The surrounding air outside the cellar such as a room, basement, garage or outdoors.
- **CFM** – Cubic feet per minute. A unit of measurement for the amount of air handled by the fan.
- **CLS** – Cubic liters per second. A unit of measurement for the amount of air handled by the fan.
- **CE** – Certificate of European conformity
- **CSA/ETL** – Canadian Standard Association/Electric Testing Laboratory
- **Drip Pad** – the wire mesh pad inside the humidifier that becomes coated with water as the water drips down by gravity. Air being drawn over the pad by a fan causes the water to evaporate into the air, increasing its moisture content.
- **Grille or Diffuser** – Inlet or outlet plates to direct the airflow or protect the inside of the unit.
- **Humidistat** – an electrical instrument that measures the relative humidity of air and reads in percent (%).
- **Humidity** – relative humidity is the percentage of moisture in the air relative to the maximum amount of moisture the air could hold at any particular condition. Relative humidity is what is most widely used and is what a humidistat measure. For example, 100% relative humidity means the air has as much moisture as it can possibly hold at that temperature. Absolute or specific humidity is the specific amount of moisture (usually measured in grains of moisture per point of air) in the air at a given air condition
- **Moisture** – water that has been evaporated into the air.
- **NEC** – National Electrical Code
- **Set point** – the desired temperature or humidity that is set on the Thermostat or Humidistat
- **UL** – Underwriters Laboratory

## General Overview

The Wine Guardian Humidifier is a self-contained unit designed specifically for wine cellars. It has been designed for easy installation and operation, either as a freestanding unit or mounted on a Wine Guardian cooling unit. Wine Guardian uses a humidistat to sense and control the amount of moisture needed to be added to the cellar. Humidifiers are not intended to remove moisture, only add moisture. All components are of a high quality, standard commercial grade. The humidifier, depending upon model, operates with 24-volt power or digital signal from the Wine Guardian control panel, and therefore does not require UL or CSA approval. All wiring complies with NEC.

Wine Guardian Humidifiers are the evaporative drip pad-type. Air from the cellar is drawn over a distribution pad that is saturated with water from a distribution tray. As the air passes through the pad, it absorbs moisture through evaporation of the water. This raises the humidity of the leaving air that returns to the cellar. Warm water is recommended for use with the humidifier (105°F - 40°C max.), however the system will work using cold water though with reduced efficiency. Warm water increases the capacity of the humidifier to evaporate the water as it passes through the pad. The

warm water also leaves fewer solids on the surfaces of the pad and flushes contaminants out of the pad. Excess water is collected in the bottom trough and exits through the drain.

To avoid build-up of mineral deposits on the pad and potentially causing blockage of the air flow, it is recommended that hard water be treated (filtered and softened). Install a 5- or 10- micron in-line water filter ahead of the humidifier to keep dirt from fouling the inlet screen and the evaporation pad inside. If the water has a high mineral content, a softener may be needed to prevent excessive scale from building up too rapidly on the pad.

Additionally, to insure adequate wetted surfaces and to help flush away excess minerals, the water flow is set to always have a flow of water to the drain. When operating, the humidifier will use approximately 1 to 2 gallons (4 to 8 liters) of water per hour depending on the water pressure in the building. About 60% of that will pass through and go out the drain. There is a strainer and an orifice in the line to restrict the flow of water, but a throttling valve may be needed to keep too much water from going to the pad. All that is needed is a steady dripping of water out of the drain to ensure adequate wetting and flushing of the pad media. Excess water does not negatively impact the humidifier's operation but neither does it contribute to more humidification. The drain volume is too much for just a bucket. A gravity drain line should be piped to an open floor or sink drain, or a condensate pump may be used where a gravity drain is impractical. This excess drain water can be discharged directly onto the ground. The discharge of the drain can be combined into the condensate drain from the cooling unit.

The humidistat, located in the cellar, will automatically turn on the humidifier whenever the cellar humidity is below the set point and turns it off when the cellar humidity reaches set point. The recommended setpoint is 55% RH for wine cellars. This humidity level is high enough to prevent corks from drying out and low enough to prevent mold from forming. When the humidifier turns on, the water solenoid valve opens, and the fan turns on. When mounted and connected to a Wine Guardian cooling unit, the humidistat also controls the main fan to circulate air to and from the cellar.

**CAREFULLY FOLLOW THE INSTALLATION INSTRUCTIONS INCLUDED WITH THE HUMIDIFIER. REFER TO THE MANUFACTURER'S INSTRUCTIONS CONTAINED IN THE BOX FOR THE HUMIDISTAT. WE RECOMMEND YOU KEEP THESE INSTRUCTIONS IN A FOLDER ALONG WITH THIS GUIDE FOR FUTURE REFERENCE.**

### **Size and Capacity**

The Wine Guardian Humidifier uses a 10" wide x 10" high x 1.5" thick (254mm wide x 254mm high x 38mm thick) expanded coated aluminum pad. Its rated output capacity for wine cellars is 1.11 lbs/HR (0.5 kg/HR) using 100°F (38°C) supply water. Humidifier capacity is rated at wine cellars conditions of 57°F/55% (14°C).



# Wiring Diagram – Integrated Humidifier (60Hz / 50Hz)

REVISIONS			
REV.	DESCRIPTION	DATE	APPROVED
A	CHANGED WIRE COLORS FROM 'YEL' TO 'BLK'	8/29/14	JFS

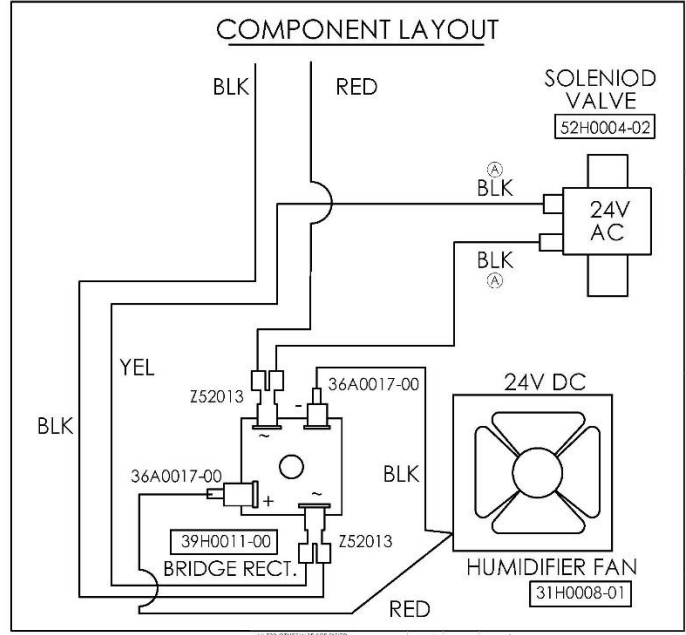
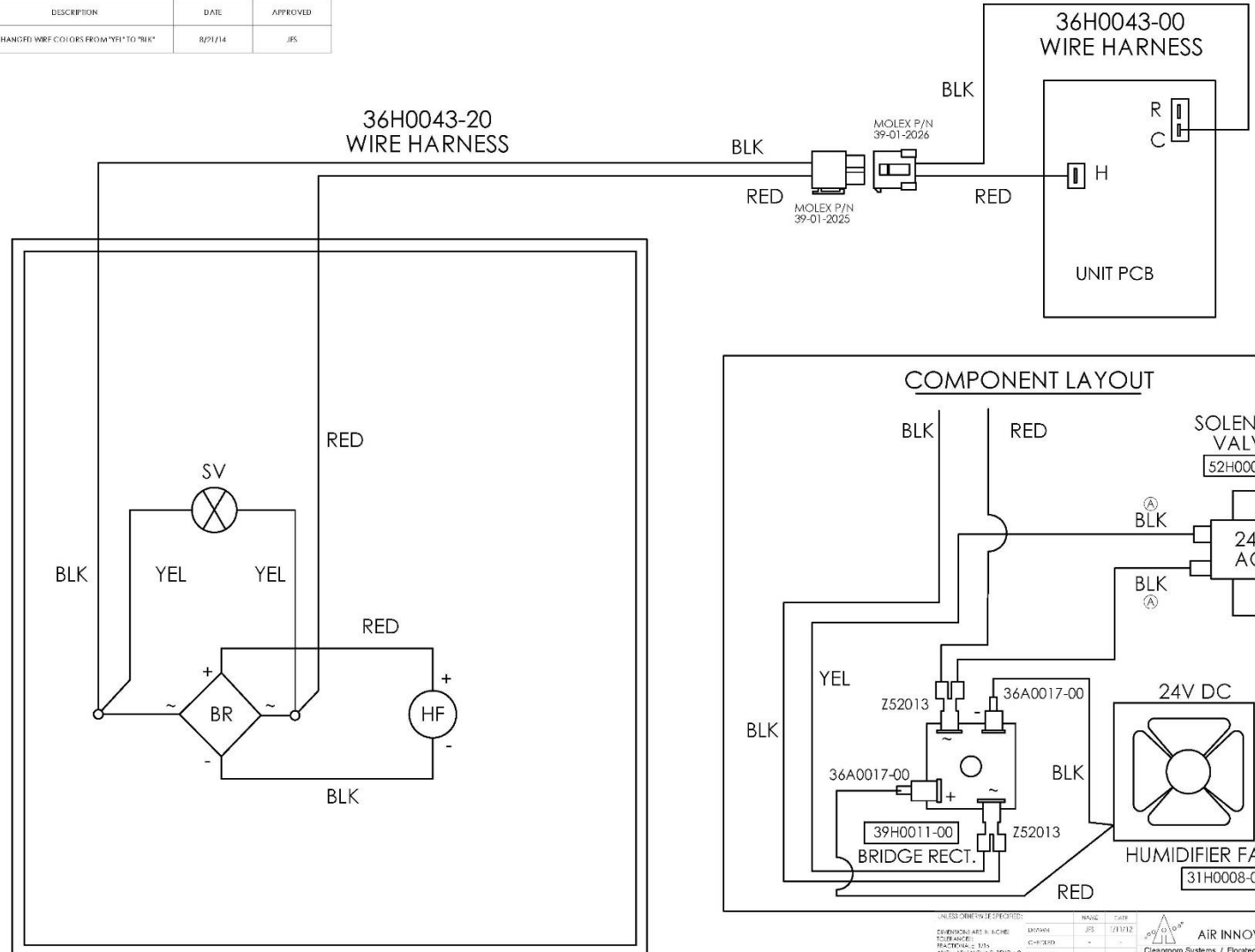

UNLESS OTHERWISE SPECIFIED:		NAME	DATE
DIMENSIONS ARE IN INCHES	SYMBOL	JFS	7/11/12
TOLERANCE:	DECIMALS		
FRACTIONS > 1/16"	FRACTIONS		
ALL DIMENSIONS ARE TO CENTER UNLESS OTHERWISE SPECIFIED	DECIMALS		
THIRD ANGLE PROJECTION	DECIMALS		
THIRD ANGLE PROJECTION	DECIMALS		
FOR THE CUSTOMER'S INFORMATION	MATERIAL		
REVISIONS	DATE		
BY	DATE		
DATE	DATE		

**AIR INNOVATIONS**  
Cleanroom Systems / Floortech  
10000 WILSON BLVD, SUITE 200, BOSTON, MA 02120

**NEW WG HUMIDIFIER WIRING**  
SIZE DWG. NO. REV  
**C 36H0042-20 A**

# Wiring Diagram – Freestanding Humidifier (60Hz)

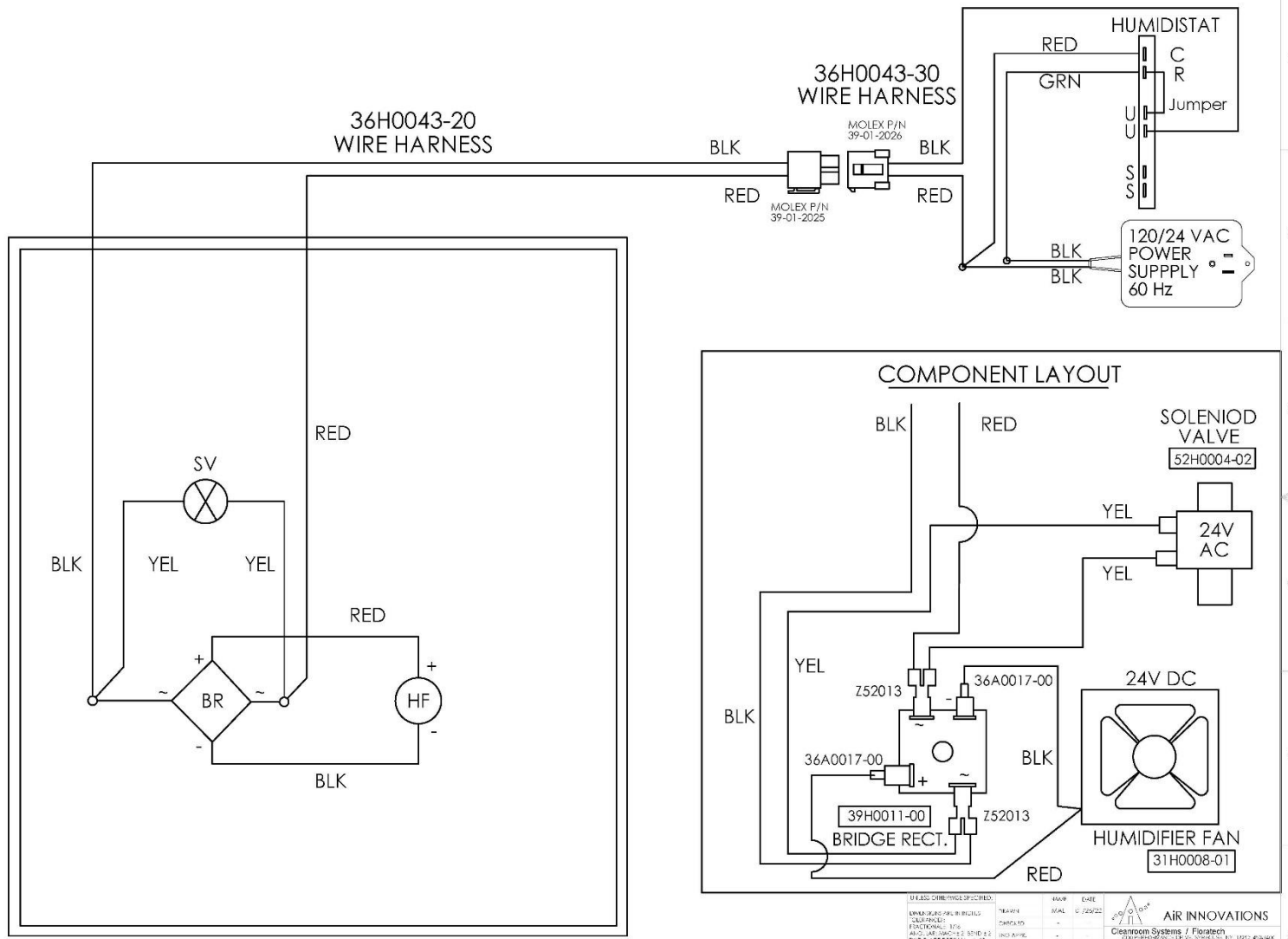

REV	DATE	BY	CHKD	APP'D
1	02/25/22			

UNLESS OTHERWISE SPECIFIED:  
 DIMENSIONS ARE IN INCHES  
 FRACTIONS 1/8, 1/4, 3/8, 1/2, 5/8, 3/4, 7/8  
 DECIMALS .005, .010, .015, .020, .030, .040, .050, .060, .070, .080, .090, .100  
 HOLE POSITIONING .010  
 UNLESS OTHERWISE SPECIFIED, DIMENSIONS ARE IN INCHES

**Air INNOVATIONS**  
 Classroom Systems / Floritech  
 1000 PARKWAY DRIVE, SUITE 100, WESTLAND, MI 48090-1000

**TITLE:** NEW WG HUMIDIFIER WIRING  
**SIZE:** C  
**DWG. NO.:** 36H0042-30  
**REV:** B  
**SCALE:** 1:1  
**SHEET:** 1 OF 1



# Humidifier Dimensions (Freestanding)

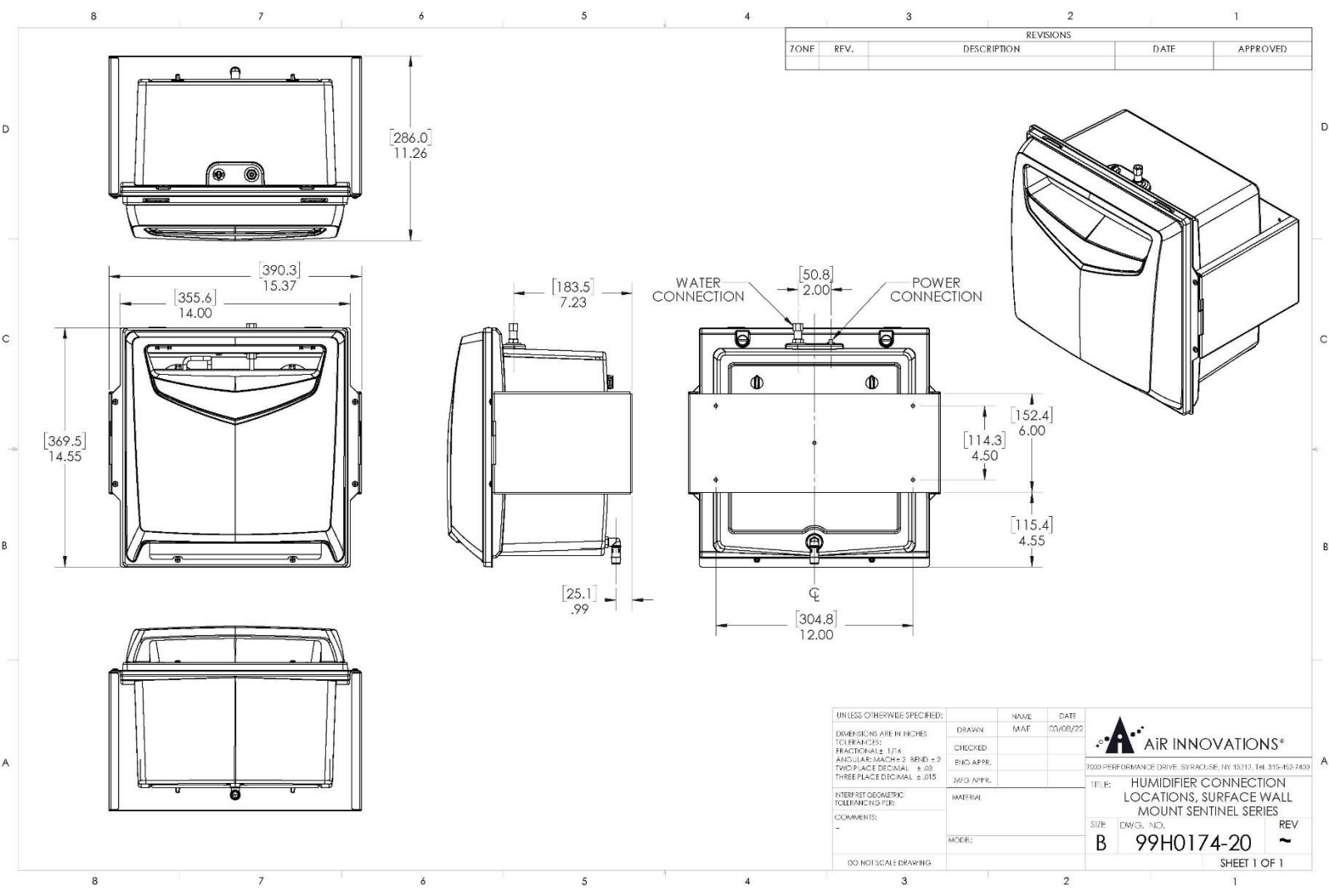

ZONE	REV.	DESCRIPTION	REVISIONS	
			DATE	APPROVED

UNLESS OTHERWISE SPECIFIED:		NAME	DATE
DIMENSIONS ARE IN INCHES		DRAWN	MMAT
TOLERANCES:		CHECKED	03/09/22
FRACTIONAL ± 1/16		ENG APPR.	
ANGULAR: MACH ± 2, BEND ± 2		MFG APPR.	
TWO PLACE DECIMAL ± .02		MATERIAL	
THREE PLACE DECIMAL ± .015			
INTERNET GEOMETRIC TOLERANCING PER:			
COMMENTS:			
-			
DO NOT SCALE DRAWING			

**AIR INNOVATIONS®**  
 2000 PERFORMANCE DRIVE, SYRACUSE, NY 13212, TEL: 315-453-7400

TITLE: HUMIDIFIER CONNECTION LOCATIONS, SURFACE WALL MOUNT SENTINEL SERIES

SIZE: DWG. NO. **B 99H0174-20** REV **~**

SHEET 1 OF 1

# Humidifier Dimensions (Integrated)

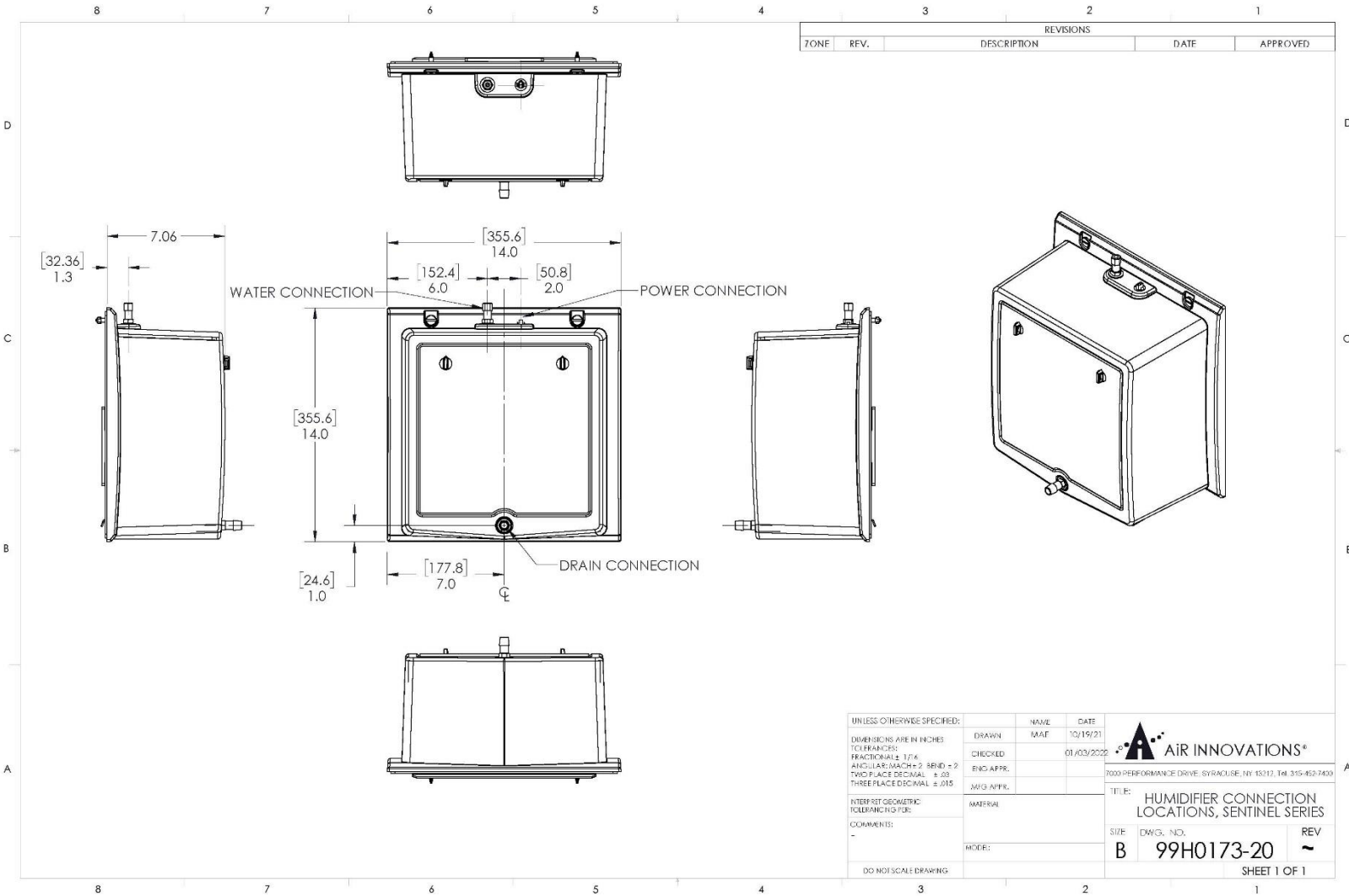

REVISIONS				
ZONE	REV.	DESCRIPTION	DATE	APPROVED

UNLESS OTHERWISE SPECIFIED:		NAME	DATE
DIMENSIONS ARE IN INCHES		DRAWN	10/19/21
TOLERANCES:		CHECKED	01/03/2022
FRACTIONAL ± 1/16		ENG APPR.	
ANGULAR: MACH ± 2 BEND ± 2		MFG APPR.	
TWO PLACE DECIMAL ± .03		MATERIAL	
THREE PLACE DECIMAL ± .015			
INTER-PT GEOMETRIC TOLERANCES:			
COMMENTS:			
DO NOT SCALE DRAWING			

**AIR INNOVATIONS®**  
7000 PERFORMANCE DRIVE, SYRACUSE, NY 13212, TEL: 315-452-7400

TITLE: **HUMIDIFIER CONNECTION LOCATIONS, SENTINEL SERIES**

SIZE: **B** DWG. NO. **99H0173-20** REV **~**

SHEET 1 OF 1

## **Installation**

For questions or help regarding installation, call customer service at 1-315-452-7400 or email [info@wineguardian.com](mailto:info@wineguardian.com) a sketch of the proposed area where the unit is to be installed.

## **Pre-Installation**



**HUMIDIFIER MAY NOT BE INSTALLED WHERE IT MIGHT BE EXPOSED TO FREEZING TEMPERATURES. IF THE COOLING UNIT IS MOUNTED OUTSIDE, THE HUMIDIFIER WILL HAVE TO BE MOUNTED IN THE SUPPLY DUCT TO THE CELLAR INSIDE THE BUILDING OR MOUNTED AS A FREESTANDING UNIT INSIDE THE CELLAR.**

To check for any possible non-visible shipping damage, you may wish to test the unit before installing it. To do so, remove the unit from its packaging and set it on any sturdy level surface. If your humidifier is a freestanding unit, plug in the unit. If the unit is to be connected to a cooling unit, you need to wire the humidifier to the cooling unit and the cooling unit must be turned on (Refer to page 14). Set the humidistat above the room humidity. The unit should now come on. The water solenoid should open, and the fan should come on. Listen for any unusual noise or vibration. Change the humidistat's set point below the room's current condition and the unit should turn off.



**NEVER MODIFY THIS EQUIPMENT. CHANGES OR MODIFICATIONS MAY VOID THE WARRANTY, CAUSE DAMAGE TO THE EQUIPMENT, AND/OR CREATE A SAFETY HAZARD.**

**NEVER PLACE ANYTHING ON TOP OF THE UNIT. NEVER BLOCK OR COVER ANY OF THE OPENINGS OR OUTLETS OF THE UNIT.**

**NEVER ALLOW ANYTHING TO REST ON OR ROLL OVER THE POWER CORD, AND NEVER PLACE THE UNIT WHERE THE POWER CORD IS SUBJECT TO WEAR OR ABUSE.**

**DO NOT REMOVE OR OPEN ANY ACCESS DOOR OR COVER UNLESS THE UNIT IS UNPLUGGED.**

## **Freestanding Installation**

1. Remove Drip Pad from plastic bag and install in unit by lifting up on the spring-loaded drip tray. (See Fig. 1 on page 14)

**Note:** The pad must be installed in the correct position. The pad must be installed with the black spot “Up”, next to the drip tray. Swing the drip tray and drip pad back to a vertical position to finish the assembly of the drip pad.

2. Attach the access panel and rotate (2) captive latches to secure the access panel to the humidifier housing.
3. Determine where unit will be mounted.
  - a. If wall mounted, use surface mount unit (99H0174-21 and 99H0185-21 for 60Hz. 99H0176-21 and 99H0186-21 for 50Hz) Secure bracket to wall (Refer to Fig. 2 on page 14). Attach humidifier to the bracket (with drain tube on bottom) using four (4) screws provided (See Fig. 4 on page 14).
  - b. If shelf mounted, place humidifier on shelf with drain tube on bottom. You may need to drill a 1” (2.5cm) diameter hole in the shelf and route the drain tube through the hole.
4. Install a ¼” (.635cm) water line from the water supply to connection at the top of the humidifier (see Fig. 7 on page 14). A shut-off valve (not provided) is recommended to isolate the humidifier from the water system when needed.
5. Install a ½” (1.2cm) flexible drain line from the bottom of the humidifier to an open drain or connect into the drain line from the cooling unit.

Proceed to Steps 6 & 7 for humidifier part number:

99H0174-21 (60Hz)

99H0176-21 (50Hz)

Proceed to Steps 8 & 9 for humidifier part number:

99H0185-21 (60Hz)

99H0186-21 (50Hz)

6. Humidifier part number 99H0174-21 uses the Remote or Local Interface Controller at the Wine Guardian system to monitor and control humidity. Plug communication cable from humidifier into the connection at the Wine Guardian unit (see Fig. 8 on page 14). The communication cable provides power and control signals to humidifier from Wine Guardian main control panel.
7. Proceed to set up of the Remote or Local Interface Controller at Wine Guardian unit to reprogram for humidity control. Starting on page 22
8. Install the humidistat on the wall where it is open to the cellar and can be read easily, approximately 60" above the floor. See section on Humidistat Mounting on page 25.
9. Plug transformer plug into wall outlet. The humidifier should now be operational.



Fig. 1



Fig. 2



Fig. 3



Fig. 4

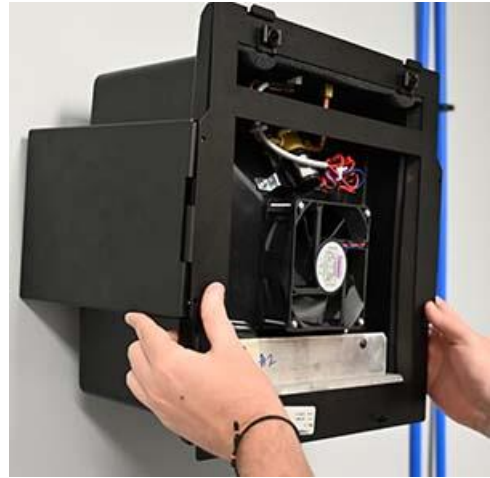

Fig. 5



Fig. 6



Fig. 7



Fig. 8



## **Integrated Installation (Sentinel)**

**Note:** Integrated humidifiers can be mounted on either of the two side openings of the cooling unit on the cooling/evaporator end only. If a duct connection is in that position, move the duct connection to the top or other side.

### **DO NOT MOUNT THE HUMIDIFIER ON THE CONDENSER END OF THE UNIT**

1. Remove Drip Pad from plastic bag and install in unit by lifting up on the spring-loaded drip tray. (See Fig. 1 on page 14)

**Note:** The pad must be installed in the correct position. The pad must be installed with the black spot “Up”, next to the drip tray. Swing the drip tray and drip pad back to a vertical position to finish the assembly of the drip pad.

2. Attach the access panel and rotate (2) captive latches to secure the access panel to the humidifier housing (See Fig. 9 on this page).
3. Remove side access panel on the side of the cooling unit where you wish to mount the humidifier.
4. Install a ½” (1.27cm) flexible drain line from the bottom of the humidifier to an open drain or connect into the drain line from the cooling unit. (
5. Install a ¼” (.635cm) warm water line from the water supply to the connection at the top of the humidifier (see Fig. 7 on page 14). A shut off valve (not provided) is recommended to isolate the humidifier from the water system when needed.
6. Connect the communication cable to the top of the humidifier and to the side of the Wine Guardian system (see Fig. 8 on page 14). The communication cable provides power and control signals to the humidifier from the Wine Guardian main control panel.
7. Proceed to set-up of Remote Interface Controller within the wine cellar to re-program for humidity control



Fig. 9



Fig. 10

### **Integrated Installation (Legacy D025, D050, & D088)**

**Note:** Integrated humidifiers can be mounted on either of the two side openings of the cooling unit on the cooling/evaporator end only. If a duct connection is in that position, move the duct connection to the top or other side.

#### **DO NOT MOUNT THE HUMIDIFIER ON THE CONDENSER END OF THE UNIT**

1. Remove Drip Pad from plastic bag and install in unit by lifting up on the spring-loaded drip tray. (See Fig. 1 on page 14)

**Note:** The pad must be installed in the correct position. The pad must be installed with the black spot “Up”, next to the drip tray. Swing the drip tray and drip pad back to a vertical position to finish the assembly of the drip pad.

2. Remove the 4 screws that secure the door on WG unit. Discard both the screws and door.
3. Attach the adaptor plate (Fig. 11) seen on the next page to the Wine Guardian unit with the (4) #8-32x1.25” screws provided.
4. Hook the cleat at bottom of the humidifier over the bottom edge of the opening on the adaptor plate.
5. Rotate the top of humidifier to the adaptor plate and secure with (2) captive latches
6. Install a ½” (1.27cm) flexible drain line from the bottom of the humidifier to an open drain or connect into the drain line from the cooling unit.
7. Install a ¼” (.635cm) warm water line from the water supply to the connection at the top of the humidifier (see Fig. 7 on page 14). A shut off valve (not provided) is recommended to isolate the humidifier from the water system when needed.
8. Connect the communication cable to the top of the humidifier and to the side of the Wine Guardian system (see Fig. 8 on page 14). The communication cable provides power and control signals to the humidifier from the Wine Guardian main control panel.
9. Proceed to set-up of Remote Interface Controller within the wine cellar to re-program for humidity control

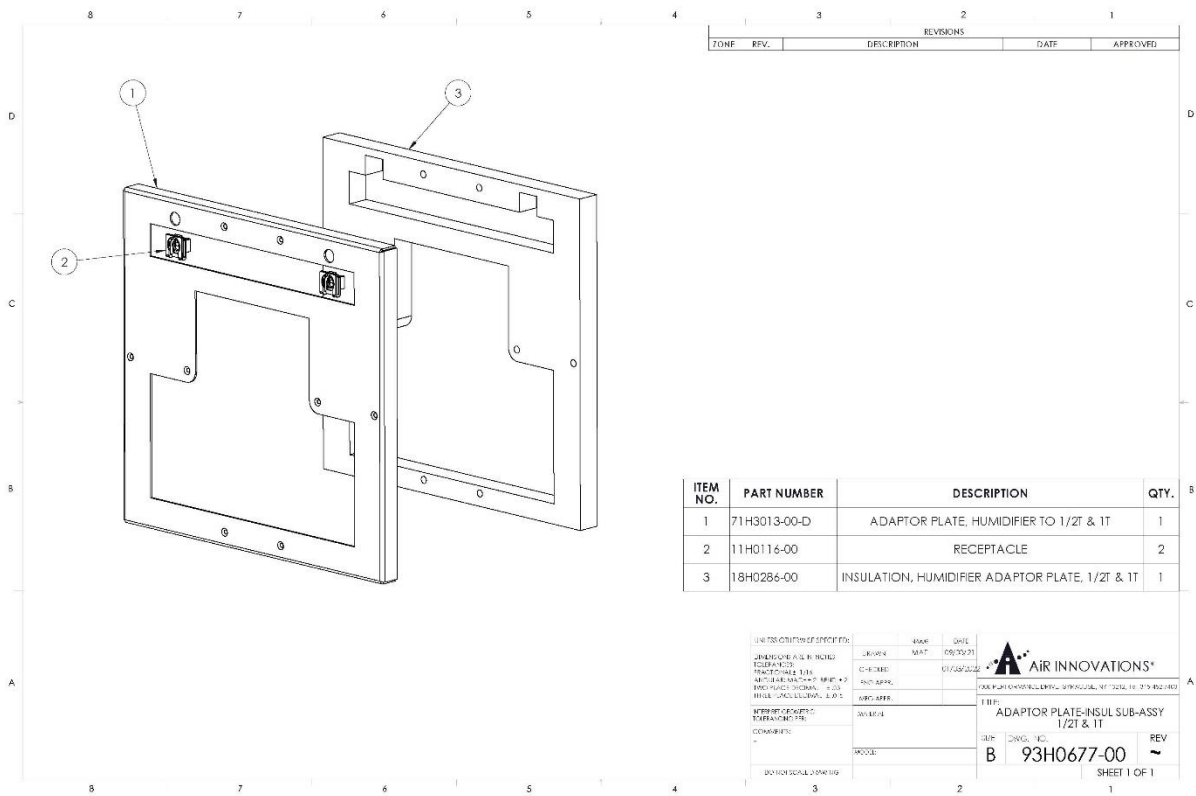

Fig. 11

## **Integrated Installation (Legacy D200)**

**Note:** Integrated humidifiers can be mounted on either of the two side openings of the cooling unit on the cooling/evaporator end only. If a duct connection is in that position, move the duct connection to the top or other side.

### **DO NOT MOUNT THE HUMIDIFIER ON THE CONDENSER END OF THE UNIT**

1. Remove Drip Pad from plastic bag and install in unit by lifting up on the spring-loaded drip tray. (See Fig. 1 on page 14)

**Note:** The pad must be installed in the correct position. The pad must be installed with the black spot "Up", next to the drip tray. Swing the drip tray and drip pad back to a vertical position to finish the assembly of the drip pad.

2. Remove the screws that secure the door on WG unit (Fig. 14 on page 20). Keep the screws and discard door.
3. Attach the adaptor plate (Fig. 13 and 14) seen on the next page to the Wine Guardian unit with the screws that were removed from the door.
4. Hook the cleat at bottom of the humidifier over the bottom edge of the opening on the adaptor plate.
5. Rotate the top of humidifier to the adaptor plate and secure with (2) captive latches (Fig. 15).
6. Install a ½" (1.27cm) flexible drain line from the bottom of the humidifier to an open drain or connect into the drain line from the cooling unit.
7. Install a ¼" (.635cm) warm water line from the water supply to the connection at the top of the humidifier (see Fig. 7 on page 14). A shut off valve (not provided) is recommended to isolate the humidifier from the water system when needed.
8. Connect the communication cable to the top of the humidifier and to the side of the Wine Guardian system (see Fig. 8 on page 14). The communication cable provides power and control signals to the humidifier from the Wine Guardian main control panel.
9. Proceed to set-up of Remote Interface Controller within the wine cellar to re-program for humidity control



Fig. 12

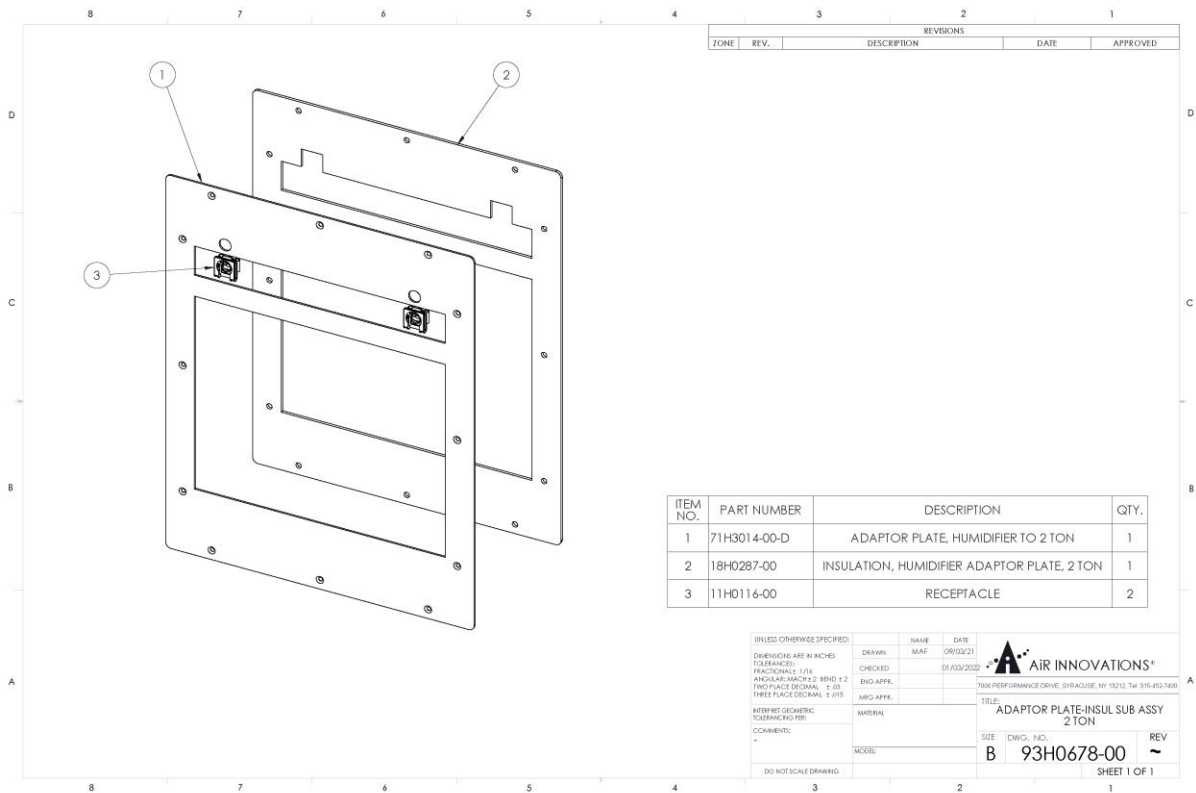

Fig. 13



Fig. 14



Fig. 15

# Start-Up

Fig A.



Fig B.

## Remote Interface Operation Guide



### Controller Functions

**ON/OFF** — The ON/OFF button will be used to turn the system on or off. When set to OFF, the control will not allow any of the outputs to energize, effectively locking the system out. It should be noted that high voltage will still be present at the main control board at the Wine Guardian unit.

**UP Arrow** — The UP arrow will allow the user to increase setpoints (%RH and temperature).

**DOWN Arrow** — The DOWN arrow will allow the user to decrease setpoints (%RH and temperature).

**SETTINGS** — The setting button will be used to select between HEAT, COOL, and AUTO, as well as entering the configuration settings. Holding the SETTINGS button for 5 seconds will enter configuration settings. Holding the SETTINGS button for 5 seconds while in configuration mode will store all changes and exit configuration model.

**For cooling operation only** — Cooling for 60Hz models is set at 55°F from the factory and 13°C for 50Hz models. This can be changed by hitting the UP or DOWN arrow. Refer to configuration settings #2 and #3 for limitations in comparison to the High and Low temperature alarm settings.

**For units with optional humidifier controlled by a Wine Guardian** — The RH% is factory set at 55%. This can be changed by referring to configuration setting #6. If no humidifier is attached, the control will only display RH%. It will not control humidity.

**Changing fan operation** — The default setting from the factory is "AUTO" fan. If desired it can be changed to fan "ON" (runs continuously) by accessing configuration setting # 7.

### Joining Communication Cable

Wine Guardian cooling systems are supplied with 50 feet (15 meters) of RJ9 control cable. Caution must be taken when connecting two lengths of communication cable (splicing) to ensure uniform wire color before and after splice. An RJ9 Modular STRAIGHT THROUGH type coupler is the ONLY coupler approved for splicing Wine Guardian twisted pair communication cable.

1. Locate the Wine Guardian remote interface controller (Fig B.) within the wine cellar or proceed to the Wine Guardian Local Interface Controller main control panel. (Fig. A)
2. Press the up arrow to ensure the controller is active. Then press the Settings button and hold it down for five (5) seconds. The screen will advance to the set up menu and "1 F" will appear on the screen. (see pictorial on page 23). For 50Hz models, default will be "1 C".
3. Continue to press the Settings button to advance to Setting 6 on the setup screen "6 0" (see page 23)
4. Press the up arrow to advance this setting to either "2" for Freestanding Humidifier or "1" for Integrated Humidifier (mounted at Wine Guardian Unit. (see page 23)
5. Controller setup is complete.



**How to:**  
Turn the System On/Off  
.....  
Press the "On/Off" button once.

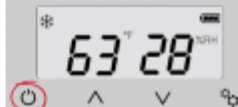

**Note:** There is a 5-minute time delay before the system turns off.

**How to:**  
Change Temperature  
.....

- Press the "Up" arrow once. The display will show the existing temperature setpoint.
- Press the up or down arrow buttons to adjust the temperature to the desired set point.



**How to:**  
Change Humidity  
.....

- Press the "Up" arrow once. This display will show the existing temperature setpoint.
- Press the "Settings" button once to display the "Humidity" setpoint.
- Press the "Up" or "Down" arrows to adjust the humidity to the desired set point.

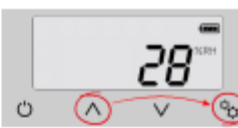

**Note:** A Wine Guardian humidifier must be installed and Setting 6 set to "1" or "2" before the controller will let you change percent humidity.

**How to:**  
Change Settings  
Cooling/Heating/Auto  
.....

- Press the Setting button once to display the setting function at the bottom of the screen.
- Press the Settings button again to scroll through settings for cool only, heat only or heat/cool only – auto mode.



**Settings – Press and hold the "Settings" button for five (5) seconds to access the following settings.**

**Setting 1:**  
Degrees F or Degrees C  
.....

- Press the "Up" arrow to change temperature from °F to °C.
- Press the "Down" arrow to change temperature from °C to °F.



**Setting 2:**  
Low Temperature Alarm Setpoint  
.....

- Press "Settings" button to advance to Setting 2.
- Press the "Up" or "Down" arrow buttons to adjust to the desired setpoint. Factory default is 50°F (10°C).



**Setting 3:**  
High Temperature Alarm Setpoint  
.....

- Press "Settings" button to advance to Setting 3.
- Press the "Up" or "Down" arrow buttons to adjust to the desired setpoint. Factory default is 65°F (18°C).

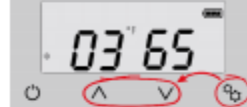

**Setting 4:**  
Low Humidity Alarm Setpoint  
.....

- Press "Settings" button to advance to Setting 4.
- Press the "Up" or "Down" arrow buttons to adjust to the desired setpoint. Factory default is 5%.

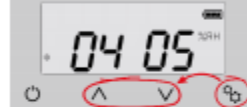

**Setting 5:**  
High Humidity Alarm Setpoint  
.....

- Press "Settings" button to advance to Setting 5.
- Press the up or down arrow buttons to adjust to the desired setpoint. Factory default is 95%.

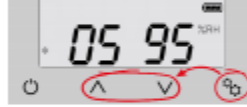

**Setting 6:**  
Add or Remove Humidifier  
.....

- Press "Settings" button to advance to Setting 6.
- Press the "Up" or "Down" arrow buttons to adjust to the desired setpoint. Factory default is zero (0).

Zero (0) = No humidifier  
One (1) = Integral Wine Guardian mounted humidifier  
Two (2) = Stand-alone remote mounted humidifier

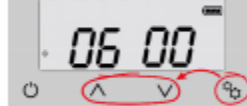

**Setting 7:**  
Fan Auto or On  
.....

- Press "Settings" button to advance to Setting 7.
- Press the "Up" or "Down" arrow buttons to adjust number to the desired set point. Factory default is zero (0).

Zero (0) = Auto-fan only turns on when there is a call for cooling or heating  
One (1) = Fan On-fan remains on continuously

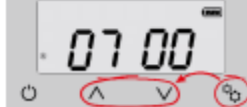



## **Mounting the Humidistat**

Freestanding humidifiers only,

- 60Hz models 99H0185-21

**Note:** Each Wine Guardian Freestanding humidifier comes with a humidistat and humidistat cable pre-wired to unit.

1. Mount the humidistat on a solid surface away from doors, corners, air outlets or other drafty or heat generating equipment. Do not mount directly on an outside wall or wall adjacent to a boiler room.
2. Use a piece of foam insulation behind the humidistat to insulate it from the hot or cold surface. The recommended height is 4 feet - 5 feet (1.2 – 1.5 meters) above the floor. The humidistat is often located next to the thermostat.



**THE HUMIDISTAT IS USED IN A BROAD RANGE OF APPLICATIONS AND THE MANUFACTURER'S LITERATURE CONTAINS INFORMATION THAT MAY NOT BE SPECIFIC TO YOUR WINE CELLAR APPLICATION. REFER TO THE MANUFACTURER'S INSTRUCTIONS CONTAINED IN THE BOX WITH THE HUMIDISTAT. WE RECOMMEND YOU FOLLOW WINE GUARDIAN'S HUMIDISTAT INSTRUCTIONS AND SIMPLY RETAIN THE HUMIDISTAT MANUFACTURER'S INSTRUCTIONS IN A FOLDER ALONG WITH THE WINE GUARDIAN OPERATION AND MAINTENANCE MANUAL FOR FUTURE REFERENCE.**

3. Disregard the wiring diagrams shown within the manufacturer's instructions. Refer to the wiring diagram shown in this guide on page 10 for 60Hz models, and page 11 for 50Hz models.

**Note:** The remote outdoor sensor is not required for wine cellar applications and should not be programmed for use.

4. Set the humidistat at the desired humidity, recommended between 55% and 60% RH, which is adequate to prevent drying out of corks. Over-humidifying can cause mold growth and sweating on surfaces and loosening of labels on bottles.

**Note:** The humidifier can only add moisture, not remove it. Removal, or dehumidification, is a function of the cooling system as it lowers the temperature of the air across the cooling coil. The humidistat will only control the addition of moisture

## **Maintenance**



**BEFORE PERFORMING MAINTENANCE ON THE UNIT, READ AND UNDERSTAND THE SAFETY INFORMATION CONTAINED IN THIS GUIDE.**

The Wine Guardian Humidifier is designed for minimal maintenance. Never oil any part of the humidifier. Always disconnect the electrical power to the humidifier and the cooling unit prior to servicing.

A regular maintenance program prolongs the life of the humidifier and maintains the humidity in the cellar. Frequency of cleaning and replacement of the drip pad depends on the inlet water conditions and the cleanliness of the cellar air. The drain system may also trap dust and dirt. When water no longer stays on the pad or mineral build-up has started to reduce airflow, the pad needs to be replaced.

### **Suggested Maintenance Schedule**

#### **Monthly**

(May change to quarterly depending on experience with individual cellar)

- Check drain – clean as needed – confirm steady flow of water while in operation
- Check for noise or vibration

#### **Yearly**

(In addition to above)

- Clean the humidifier and replace humidifier pad if needed (see procedures below)
- Check for any loose fasteners, gaskets, or connections
- Check wiring connections and integrity of cords
- Check operation of humidifier fan and water solenoid
- Check to be sure the water supply tube is aimed at the center of the distribution tray between the two center holes.

## Replacing the Drip Pad



**BEFORE STARTING WORK, BE SURE THE POWER TO THE WINE GUARDIAN COOLING UNIT AND HUMIDIFIER ARE TURNED OFF. MAKE SURE THE POWER CORD IS DISCONNECTED FROM THE POWER SOURCE.**

1. Start by disconnecting the electrical power and shutting off the water supply.
2. Remove the access panel at the back of the humidifier.
3. Remove the drip pad by lifting up on the spring-loaded drip tray.
4. To clean the drain, pour some hot water mixed with a cleaning solution into the drain area of the humidifier to flush the dirt down the drain tube.
5. Check the humidifier pad. If dirty or excessive mineral deposits are present, install a new evaporative pad. Replace the pad by lifting up on the spring-loaded drip tray.

**Note:** the pad must be installed in the correct position. There is a black spot painted on one end of the pad. This is the top of the pad and must be installed with the black spot UP, next to the distribution tray. There is no inlet or outlet side for the airflow, only the requirement that the black spot be on the top.

6. Be sure the water feed tube is aimed into the center of the distribution tray.
7. Turn on the water and power.
8. Check for operation. See instructions under Start-Up. Be sure water is flowing into the distribution tray and flows freely out the holes and over the pad. If water flow is not a steady flow, the strainer and/or orifice may need service.
9. Re-install the humidifier access cover

## **Water Line Maintenance**

1. Start by disconnecting the electrical power and shutting off the water supply.
2. Remove front cover of humidifier or remove humidifier from ducted Wine Guardian unit (depending on your set-up).
3. Disconnect the water line at the inlet to the solenoid valve.
4. Remove the in-line strainer from inside the inlet fitting using caution to avoid penetrating the strainer and rendering it useless.
5. Clean the strainer by flushing under hot water or immersing in a demineralizing solution to break down the mineral deposits. Inspect and replace the strainer if it cannot be cleaned or if the screen is damaged.
6. Reinstall the strainer in the valve inlet, replace the tubing, and tighten the compression nut. Double wrench to prevent damage and leaks.
7. Disconnect the water line on the outlet of the solenoid valve.
8. Remove the orifice from the copper tube and make sure this small opening is unplugged.
9. Replace the orifice and reconnect the outlet water line. Double wrench to prevent leaking.
10. Reinstall the in-line strainer and reconnect the inlet water line. Double wrench to prevent leaking.
11. Turn on water supply and reconnect electrical power to the humidifier.
12. Check to be sure the water supply tube is aimed at the center of the distribution tray between the two center holes. This will ensure even distribution of water across the entire tray and equally into each of the six holes, thereby evenly wetting the entire surface of the drip pad.

## **Contact and Warranty**

Warranty outside of the U.S. is determined by the country. Refer to your distributor for your Wine Guardian warranty.

### **GENERAL**

Wine Guardian warrants, to the original buyer, its goods and all parts thereof to be free from defects in material and workmanship for a period of two (2) years from the date of invoicing assuming NORMAL USE AND SERVICE. LIABILITY

Wine Guardian liability shall be limited to the repair or replacement (at its option) of any part, which, at our sole discretion, is determined to be defective. The purchaser shall pay all transportation costs. Additionally, if a malfunction occurs within the first year from the date of invoice, Wine Guardian will reimburse the reasonable cost of labor required for the repair or replacement provided authorization is obtained from one of our authorized representatives prior to incurring any labor charges.

### **LIMITATIONS OF LIABILITY**

THESE WARRANTIES ARE MADE IN LIEU OFF ALL OTHER WARRANTIES EXPRESSED OR IMPLIED, INCLUDING ANY IMPLIED WARRANTY OF MERCHANTABILITY OR FITNESS FOR A PARTICULAR PURPOSE AND IN LIEU OF ANY OTHER OBLIGATION OR LIABILITY, INCLUDING LIABILITY FOR ANY INCIDENTAL OR CONSEQUENTIAL DAMAGES. Wine Guardian will not be responsible for any costs or liabilities whatsoever resulting from improper installation or service of its equipment. In the event that Wine Guardian or its distributors are found liable for damage based on any defect or nonconformity in the products, their total liability for each defective product shall not exceed the purchase price of such defective products. No person or representative is authorized to change these warranties or assume any other obligations or liabilities for Wine Guardian in connection with the sale of its systems.

### **INDEMNIFICATION**

Purchaser agrees to indemnify, hold harmless and defend seller and its officers, directors, agents and employees from and against any and all claims, liabilities, costs and expenses arising out of or related to Purchaser's use of the goods, or in any way involving injury to person or property or accident occasioned by the goods sold by Wine Guardian to Purchaser.

### **FOREIGN GOVERNMENT AND INDIAN NATIONS**

If Purchaser is a foreign government or an Indian nation, Purchaser hereby expressly waives its defense of sovereign immunity in the event of a dispute between Purchaser and Wine Guardian regarding this invoice and Purchaser expressly acquiesces to the jurisdiction of the federal and state courts of the United States.

## SEVERABILITY

If one or more of the provisions contained in this contract shall for any reason be held to be invalid, illegal, or unenforceable in any respect, such invalidity, illegality or unenforceability shall not affect any provision of this contract, but this contract shall be construed as if such invalid, illegal or unenforceable provision had never been contained.

## ADDITIONAL REQUIREMENTS

If a defect covered by the Warranty occurs, contact Wine Guardian for authorization to proceed with corrective action. Do not return any parts or incur any charges for which you expect to be reimbursed under this Warranty without receiving this authorization. If parts are replaced under this Warranty, the defective parts must be returned prepaid within 30 days. This warranty shall be null and void in its entirety if the Serial Number on the air conditioner or compressor is altered, removed, or defaced.

### ***Wine Guardian***

 ***An Air Innovations Company***

***7000 Performance Drive***

***North Syracuse, NY 13212***

***[www.wineguardian.com](http://www.wineguardian.com) ~ 800-825-3268***

***Rev. 3/2022***