



# Installation, Start-Up and Configuration Instructions

Part Number 33ZCVVTZC-01

## CONTENTS

	Page
<b>SAFETY CONSIDERATIONS</b> .....	1
<b>GENERAL</b> .....	2
<b>INSTALLATION</b> .....	2-26
<b>General</b> .....	2
<b>Zone Controller Hardware</b> .....	2
<b>Field-Supplied Hardware</b> .....	2
• SPACE TEMPERATURE SENSOR	
• OPTION BOARD	
• PRIMARY AIR TEMPERATURE SENSOR	
• SUPPLY AIR TEMPERATURE (SAT) SENSOR	
• DUCT AIR TEMPERATURE SENSOR	
• RELATIVE HUMIDITY SENSOR	
• INDOOR AIR QUALITY (CO <sub>2</sub> ) SENSOR	
<b>Mount Zone Controller</b> .....	4
• LOCATION	
• MOUNTING	
<b>Connect the Power Transformer</b> .....	5
<b>Install Sensors</b> .....	15
• SPACE TEMPERATURE SENSOR INSTALLATION	
• SYSTEM PILOT	
• PRIMARY AIR TEMPERATURE SENSOR INSTALLATION	
• DUCT TEMPERATURE SENSOR (33ZCSENDAT) INSTALLATION	
• SUPPLY AIR TEMPERATURE (33ZCSENSAT) SENSOR INSTALLATION	
• INDOOR AIR QUALITY SENSOR INSTALLATION	
• HUMIDITY SENSOR (WALL-MOUNTED) INSTALLATION	
<b>Remote Occupancy Contact</b> .....	21
<b>Connect the Outputs</b> .....	21
<b>Modulating Baseboard Hydronic Heating</b> .....	23
<b>Connect the Carrier Communicating Network</b>	
<b>Communication Bus</b> .....	23
• COMMUNICATION BUS WIRE SPECIFICATIONS	
• CONNECTION TO THE COMMUNICATION BUS	
<b>START-UP</b> .....	26-29
<b>Perform System Checkout</b> .....	26
<b>Network Addressing</b> .....	27
<b>Initial Operation and Test</b> .....	27
<b>Fan and Heat Configuration and Test</b> .....	27
<b>System Balancing</b> .....	27
<b>Status Table</b> .....	28
<b>CONFIGURATION TABLES</b> .....	29-39
<b>Alarm Configuration Table</b> .....	29
<b>Terminal Service Configuration Table</b> .....	30
<b>Damper Service Configuration Table</b> .....	33
<b>Holiday Configuration Table</b> .....	33
<b>Linkage Configuration Table</b> .....	33
<b>Language Configuration Table</b> .....	35

<b>Master Service Configuration Table</b> .....	35
<b>Time Schedule Configuration Table</b> .....	36
<b>Option Service Configuration Table</b> .....	37
<b>Set Point Configuration Table</b> .....	39
<b>MAINTENANCE TABLES</b> .....	40-51
<b>System Pilot Maintenance Table</b> .....	40
<b>System Pilot Alternate Maintenance Table</b> .....	40
<b>Linkage Maintenance Table</b> .....	41
<b>Master Zone Maintenance Table</b> .....	43
<b>Time Schedule Maintenance Table</b> .....	44
<b>System Commissioning Maintenance Table</b> .....	45
<b>Zone Status Maintenance Table</b> .....	47
<b>Zone Device Maintenance Table</b> .....	47
<b>Zone Maintenance Table</b> .....	47
<b>Zone Commissioning Maintenance Table</b> .....	50
<b>OPERATION</b> .....	51-54
<b>System Mode Selection</b> .....	51
<b>Linkage</b> .....	52
• AIR SOURCES THAT SUPPORT LINKAGE	
• NON-LINKAGE CONTROLLED AIR SOURCES	
<b>System Modes</b> .....	53
<b>Air Terminal Modes</b> .....	53
<b>APPENDIX A — SYSTEM OPERATION</b>	
<b>FLOW CHARTS</b> .....	55-58

## SAFETY CONSIDERATIONS

### SAFETY NOTE

Air-conditioning equipment will provide safe and reliable service when operated within design specifications. The equipment should be operated and serviced only by authorized personnel who have a thorough knowledge of system operation, safety devices and emergency procedures.

Good judgement should be used in applying any manufacturer's instructions to avoid injury to personnel or damage to equipment and property.

### ⚠ WARNING

Disconnect all power to the unit before performing maintenance or service. Unit may automatically start if power is not disconnected. Electrical shock and personal injury could result.

### ⚠ WARNING

If it is necessary to remove and dispose of mercury contactors in electric heat section, follow all local, state, and federal laws regarding disposal of equipment containing hazardous materials.

## GENERAL

The zone controller is a single duct, fan powered, Variable Volume and Temperature (VVT®) terminal control with a factory-integrated controller and actuator. The VVT zone controller maintains precise temperature control in the space by operating the terminal fan and regulating the flow of conditioned air into the space. Buildings with diverse loading conditions can be supported by controlling equipment heating and cooling sources or supplemental heat.

The VVT zone controller (33ZCVVTZC-01) provides dedicated control functions for single duct terminals with modulating heat, up to 3 stages of ducted heat, or combination baseboard and ducted heat. A relay board (33ZCOPTBRD-01) is required for heat or fan terminals.

Carrier's 3V™ control system provides optimized equipment and component control through airside linkage. Linkage refers to the process through which data is exchanged between the air terminals and the air source that provides the supply air to those terminals. The process "links" the terminals and the air source to form a coordinated system. Linkage allows the air source to operate efficiently and reliably while responding to and satisfying changing conditions in the zones. Linkage also allows the terminals to respond properly to changes in the air source. A VVT zone controller configured as the Linkage Coordinator manages the flow of data between the air source and the VVT system zones.

Rooftop units, air handlers, fan coils, and water source heat pumps feature product integrated or factory-installed controls that are directly compatible with the 3V control system. The rooftop units, air handlers, fan coils, and water source heat pumps do not require any special hardware to be compatible with the Carrier linkage system. Consult your local Carrier representative for the complete list of compatible air source controllers. Figure 1 shows an example of a Carrier linkage system.

The VVT zone controllers are available factory-mounted to Carrier's round and rectangular dampers. Round dampers are available in 6, 8, 10, 12, 14, and 16-in. sizes. Rectangular dampers are available in 8x10, 8x14, 8x18, and 8x24-in. sizes. All damper assemblies are equipped with an integrated duct temperature sensor.

## INSTALLATION

**General** — The VVT zone controller is a microprocessor-based direct digital control (DDC) controller that can be purchased or installed on variable volume and temperature (VVT) air terminals. It can be retrofitted on units manufactured by Carrier or other manufacturers to provide pressure dependent VVT control.

Each zone controller has the ability to function as a linkage coordinator for systems with up to 32 zones. As a linkage coordinator, a zone controller will retrieve and provide system information to the rooftop or air-handling equipment and other zone controllers. A zone controller can function as a stand alone device by installing a duct air sensor.

The zone controller is connected to a wall-mounted, field-supplied, space temperature sensor (SPT) in order to monitor zone temperature changes and satisfy zone demand.

On stand-alone applications or applications with ducted or modulating heat, the zone controller must be connected to a field-supplied supply air temperature (SAT) sensor to monitor the temperature of the air delivered by the air terminal. A System Pilot can be used to adjust set points, set operating parameters, and fully configure the zone controller or any device on the system. A System Pilot can also provide local space temperature, set point adjust, time broadcast, and schedule adjustment for a single dedicated or remote device.

Carrier's network software can be connected to the system at the SPT sensor if Carrier network communication wiring is run to the SPT sensor. The network software can be used to adjust set points, set operating parameters, and fully configure the zone controller or any device on the system.

**Zone Controller Hardware** — The zone controller consists of the following hardware:

- terminal control module
- torque-limiting integrated damper actuator
- plastic enclosure
- one no. 8 x 1/2-in. self-drilling sheet metal screw (to prevent zone controller rotation)

Figure 2 shows the zone controller physical details.

**Field-Supplied Hardware** — Each zone controller requires the following field-supplied components to complete its installation:

- air terminal unit (unless factory installed — when purchased as factory-installed option an SAT [supply-air temperature] sensor is provided upstream of the damper blade)
- round or rectangular mounting bracket (for retrofit applications)
- space temperature sensor
- transformer — 24 vac, 40 va
- two no. 10 x 1/2-in. sheet metal screws (to secure SAT sensor to duct, if required)
- two no. 6-32 x 5/8-in. screws (to mount SPT [space temperature] sensor base to electrical box)
- contactors (if required for fan or electric heat)
- supply air temperature sensor (required for terminal with ducted heat)
- option board 33ZCOPTBRD-01 (required for auxiliary heat or fan terminals)
- indoor air quality sensor (if required)
- relative humidity sensor (if required)
- one SPST (single pole, single throw) relay
- valve and actuator for hot water heat (if required)
- wire
- bushings (required when mounting SAT sensor in a duct 6-in. or less in diameter)
- primary air temperature sensor (if required)

**SPACE TEMPERATURE SENSOR** — Each zone controller requires a field-supplied Carrier space temperature sensor. There are three sensors available for this application:

- 33ZCT55SPT, Space Temperature Sensor with Override Button
- 33ZCT56SPT, Space Temperature Sensor with Override Button and Set Point Adjustment
- 33PILOT-01, System Pilot Space Temperature Sensor, User Interface, and Configuration Device

The System Pilot is a user interface to the Zone Controller with a full complement of zone display features that can be used to configure and operate the Zone Controller. It has an SPT sensor and can transmit its value to the Zone Controller. The System Pilot communicates to the Zone Controller through the Zone Controller's dedicated Comm2 port or over the main communication bus through Comm1.

**OPTION BOARD** — The option board (33ZCOPTBRD-01) is required for use of auxiliary heat and fan control functions. The Option Board is field installed and provides four triac discrete outputs, three for supplemental heat and one for the fan output.

**PRIMARY AIR TEMPERATURE SENSOR** — A field-supplied, primary air temperature (PAT) sensor (part number 33ZCSENPAT) is used on a zone controller which is functioning as a Linkage Coordinator for a non Carrier Network/Linkage compatible air source.

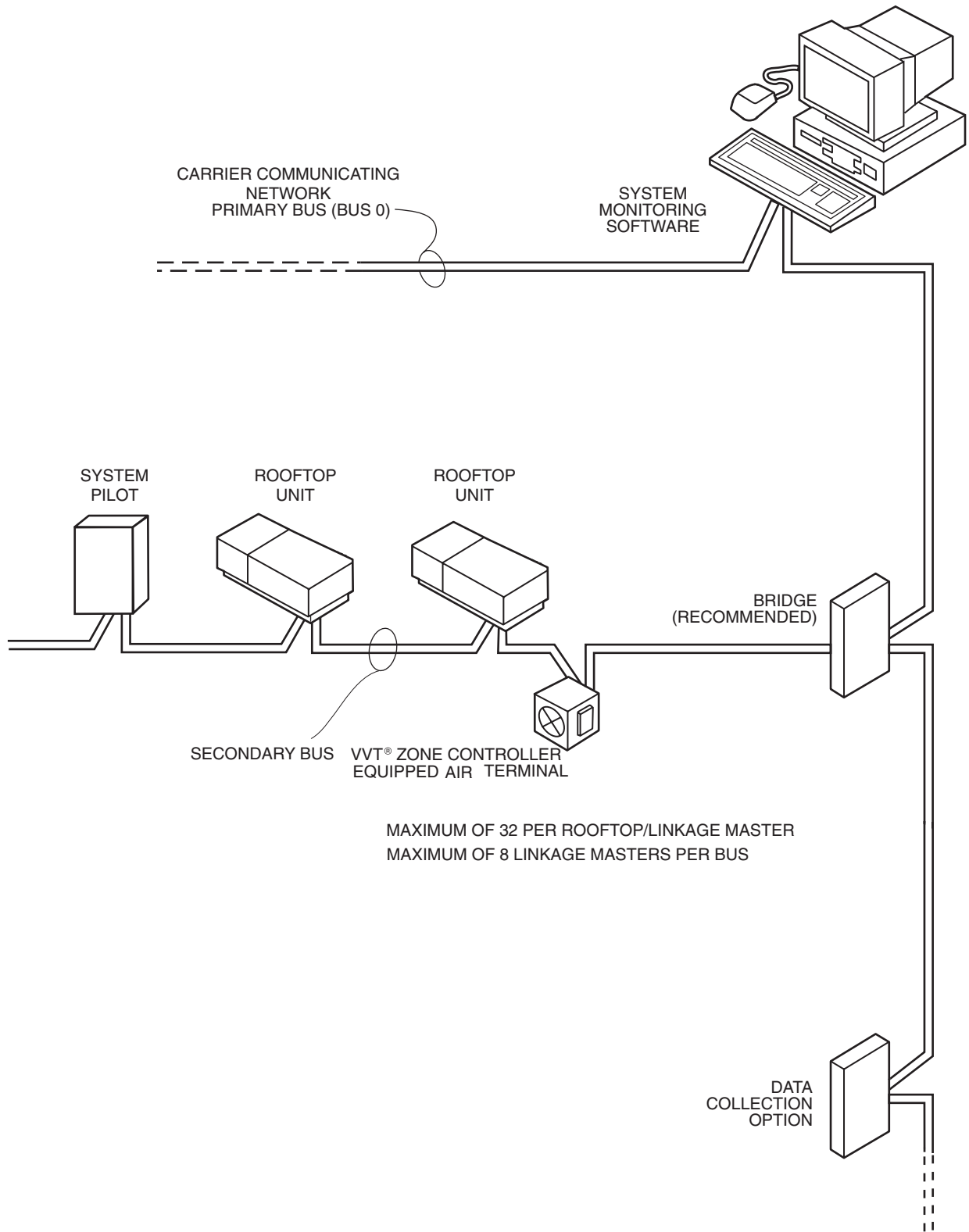

**Fig. 1 — Typical Carrier Linkage System**

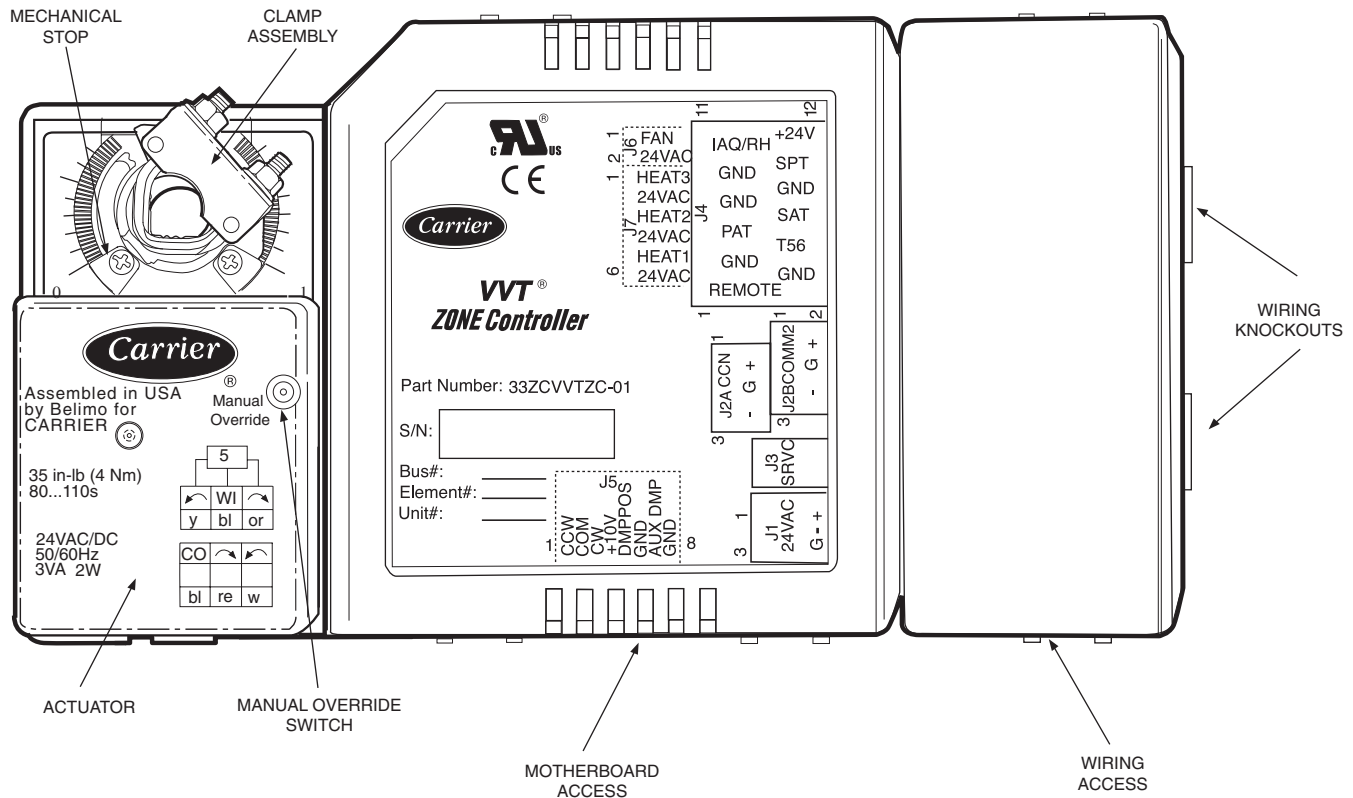

**Fig. 2 — Zone Controller**

**SUPPLY AIR TEMPERATURE (SAT) SENSOR** — The 33ZCSENSAT supply air temperature sensor is required for reheat applications or stand-alone operation. The sensor has an operating range of  $-40$  to  $245$  F ( $-40$  to  $118$  C) and includes a 6-in. stainless steel probe and cable.

**DUCT AIR TEMPERATURE SENSOR** — The 33ZCSENDAT Duct Air Temperature Sensor is required for cooling only applications on non-33CS or non-Carrier dampers. The sensor is used for supply air monitoring. The sensor has an operating range of  $-40$  to  $245$  F ( $-40$  to  $118$  C) and includes a mounting grommet and 75-in. cable.

**RELATIVE HUMIDITY SENSOR** — The 33AMSENHRHS000 relative humidity sensor is required for zone humidity control (dehumidification) when in a linked system with a rooftop unit equipped with a dehumidification device. Otherwise, the RH sensor is used for monitoring only.

**NOTE:** The relative humidity sensor and CO<sub>2</sub> sensor cannot be used on the same zone controller.

**INDOOR AIR QUALITY (CO<sub>2</sub>) SENSOR** — An indoor air quality sensor is required for optional demand control ventilation. The 33ZCSENCO2 CO<sub>2</sub> sensor is an indoor, wall mounted sensor with an LED display. The 33ZCT55CO2 and 33ZCT56CO2 CO<sub>2</sub> sensors are indoor, wall-mounted sensors without display.

**NOTE:** The relative humidity sensor and CO<sub>2</sub> sensor cannot be used on the same zone controller.

**Mount Zone Controller (Retrofit Applications)** — The zone controller is factory-mounted on Carrier round and rectangular dampers. When retrofitting a zone controller on an existing damper, perform the following procedures.

**LOCATION** — The zone controller must be mounted on the air terminal's damper actuator shaft. For service access, there

should be at least 12 in. of clearance between the front of the zone controller and adjacent surfaces. Refer to Fig. 3.

**MOUNTING** — Perform the following steps to mount the zone controller:

1. When retrofitting a zone controller on an existing damper, prior to installing the zone controller, remove all existing hardware.
2. Round or rectangular damper brackets may be attached to the damper to provide a clearance for the damper bearing when the zone controller is installed on older style VVT® dampers. The zone controller is used to determine the location of the bracket. Attach the bracket to the zone controller using a single screw through the anti-rotation tab.
3. Visually inspect the damper and determine the direction in which the damper shaft moves to open the damper — clockwise (CW) or counterclockwise (CCW). Refer to Fig. 4.

If the damper rotates CCW to open, it does not require any configuration changes.

If the damper rotates CW to open, then the damper actuator logic must be reversed. This is done in the software when performing system start-up and damper calibration test. Do not attempt to change damper rotation by changing wiring. This will upset the damper position feedback potentiometer readings.

4. Rotate the damper shaft to the fully closed position. Note direction of rotation.
5. Press the release button on the actuator and rotate the clamp in the same direction that was required to close the damper in Step 4.
6. Press the release button on the actuator and rotate the actuator back one position graduation. Release the button and lock the actuator in this position.

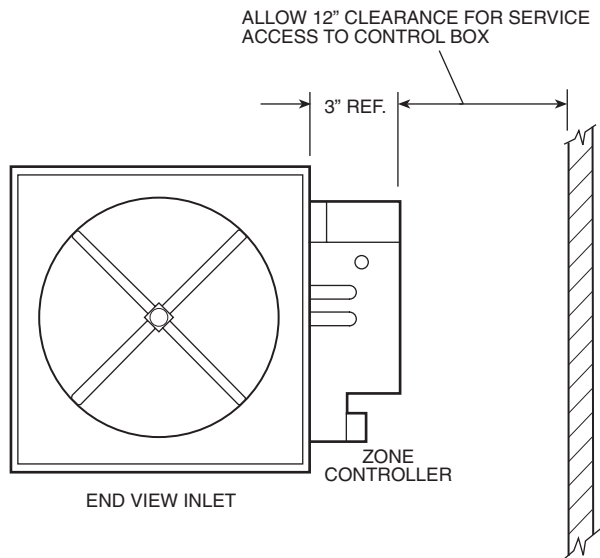

**Fig. 3 — Service Clearance for Zone Controller Mounting**

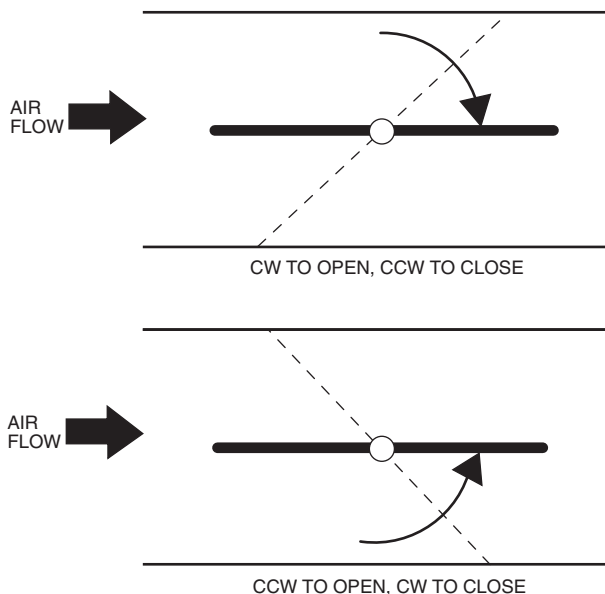

**Fig. 4 — Damper Configuration**

7. Mount the zone controller to the terminal by sliding the damper shaft through the actuator clamp assembly. Secure the zone controller to the duct by installing the screw provided through the grommet in the anti-rotation tab or by attaching the mounting bracket to the damper. Be sure the floating grommet is in the center of the slot. Failure to center the grommet may cause the actuator to stick or bind.
8. Tighten the actuator clamp assembly to the damper shaft. Secure by tightening the two 10-mm nuts.

9. If the damper has less than 90 degrees of travel between the fully open and fully closed positions, then a mechanical stop must be set on the actuator. The mechanical stop prevents the damper from opening past the maximum damper position. To set the mechanical stop, perform the following procedure:
  - a. Press the actuator release button and rotate the damper to the fully open position.
  - b. Using a Phillips screwdriver, loosen the appropriate stop clamp screw.
  - c. Move the stop clamp screw so that it contacts the edge of the cam on the actuator. Secure the stop clamp screw in this position by tightening the screw.
10. Verify that the damper opens and closes. Press the actuator release button and rotate the damper. Verify that the damper does not rotate past the fully open position. Release the button and lock the damper in the fully open position.

**NOTE:** The actuator must rotate to the end of the actuator range in the fully closed position. For actuators with less than 90 degrees of travel, the opposite stop must be moved so the actuator travels to mid-range when fully open. Damper calibration will fail if stops on actuator are not set correctly.

**Connect the Power Transformer —** An individual, field-supplied, 24-vac power transformer is recommended for each zone controller. If multiple zone controllers are powered from one power transformer (100 va maximum for UL [Underwriters' Laboratories] Class 2 conformance), maintain polarity on the power input terminals. All transformer secondaries are required to be grounded. Use only stranded copper conductors for all wiring to the zone controller. Wiring connections must be made in accordance with NEC (National Electrical Code) and local codes. Ground the transformer at the transformer location. Provide an 18-gage, green, chassis ground wire at the terminal.

The power supply is 24 vac  $\pm$  10% at 40 va (50/60 Hz).

For VVT® zone controllers, the power requirement sizing allows for accessory water valves and for electric heat contactor(s). Water valves are limited to 15 va on both two-position and modulating hot water. The electric heat contactor(s) are limited to 10 va (holding) each.

**NOTE:** If a water valve or electric heat contactor exceeds these limits, or external contactors are required for electric heat, then it is recommended a 60 va transformer be used. The maximum rating for any output is 20 va.

**NOTE:** Do not run sensor or communication wiring in the same conduit with line-voltage wiring.

**NOTE:** A conduit cover is provided and integrated with the zone controller.

Perform the following steps to connect the power transformer:

1. Install the field-supplied transformer in an electrical enclosure that conforms to NEC and local codes.
2. Connect 24 vac from the transformer as shown in the applicable wiring diagram (Fig. 5-13).

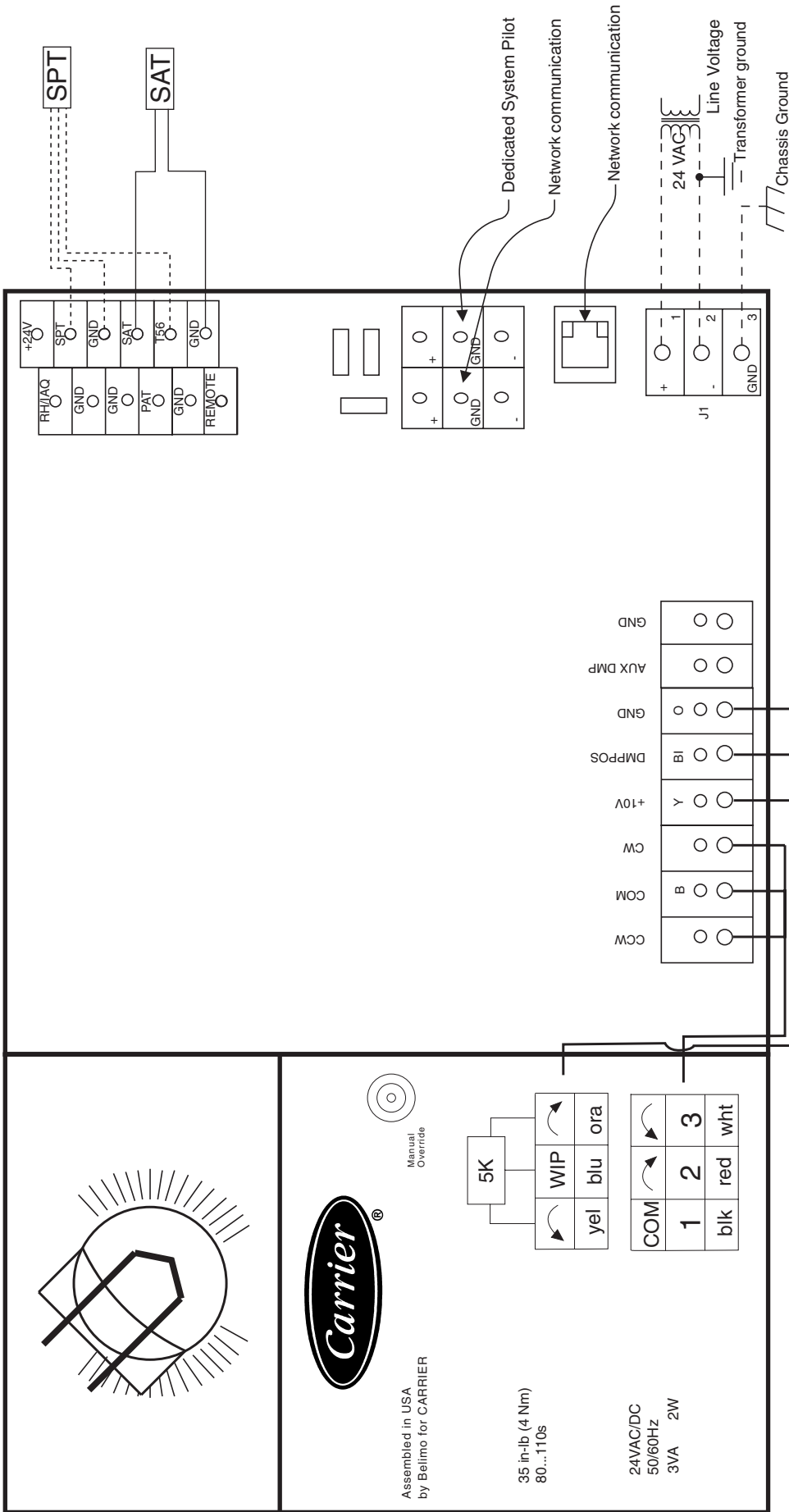

NOTE: The SAT may be relocated to sense and control ducted heat.

→ Fig. 5 — VWT@ Zone Controller Wiring — Single Duct

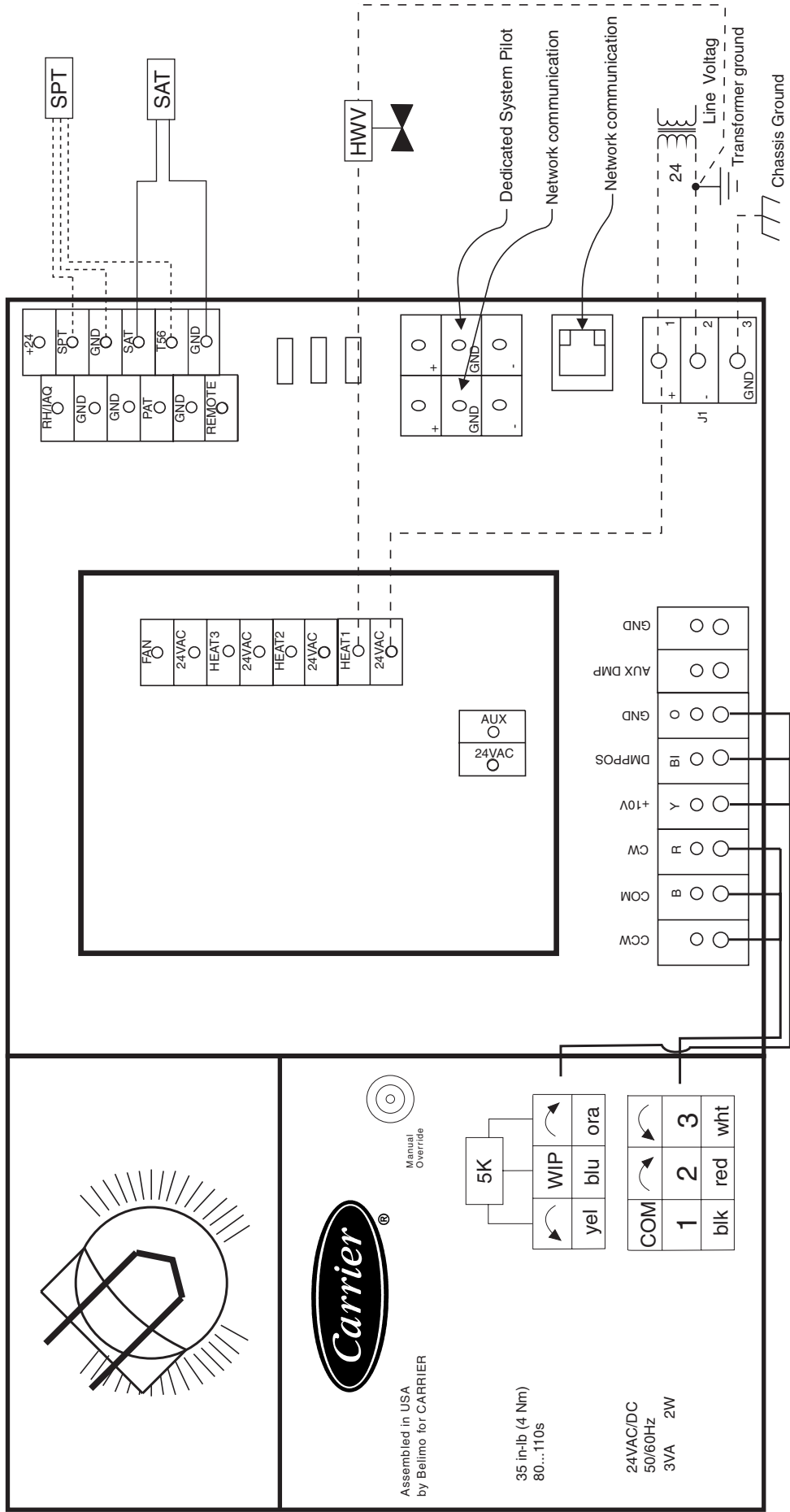

NOTE: The SAT may be relocated to sense and control ducted heat.

- LEGEND**
- CCW Counter-clockwise
  - COM Common
  - CW Clockwise
  - DMPPOS Damper Position
  - GND Ground
  - HWV Hot Water Valve
  - IAQ Indoor Air Quality
  - PAT Primary Air Temperature Sensor
  - RH Relative Humidity
  - SAT Supply Air Temperature Sensor
  - SPT Space Temperature Sensor
  - Field-Supplied Wiring
  - Factory Wiring

→ Fig. 6 — VWT® Zone Controller Wiring — Single Duct Two-Position Hot Water Heat

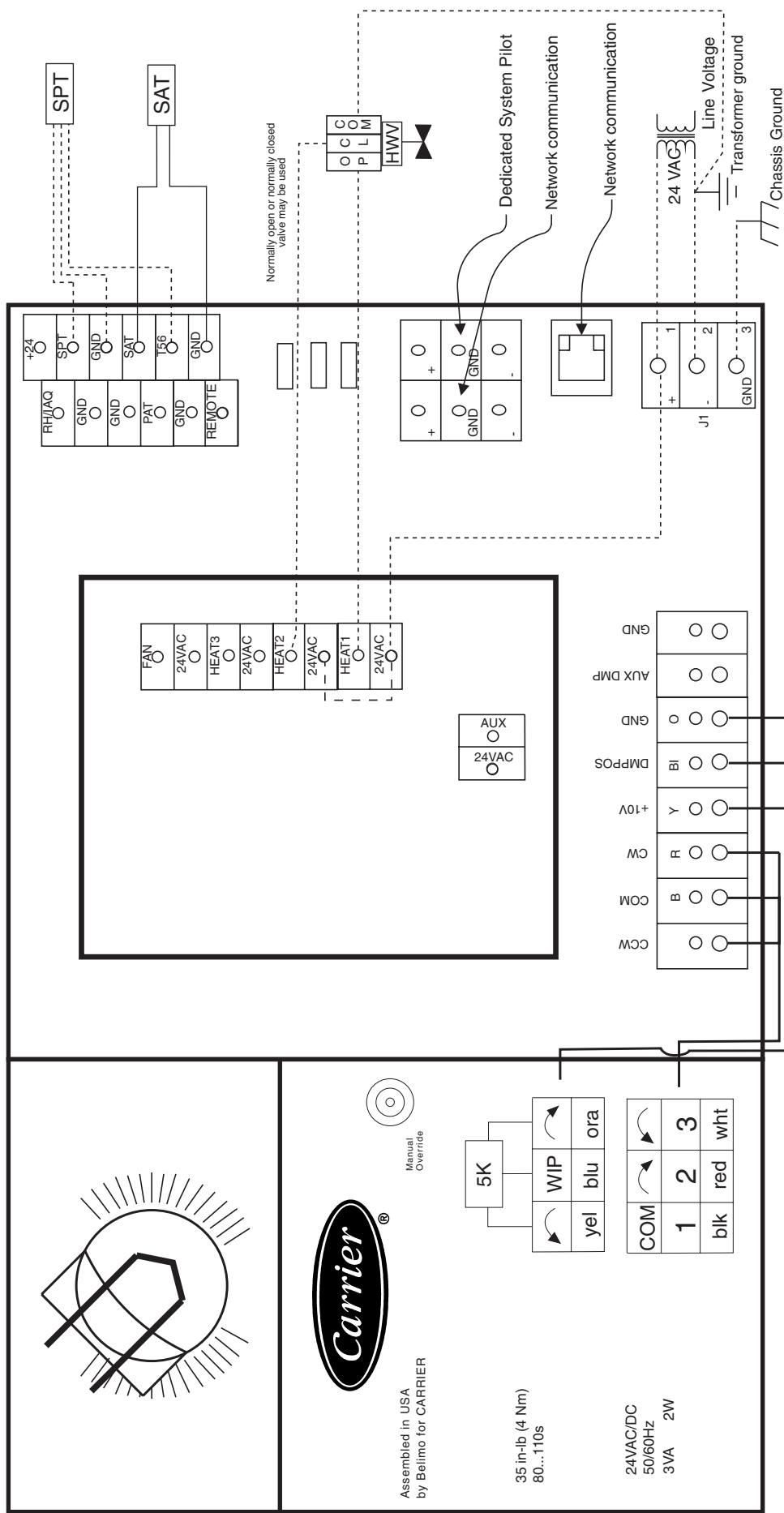

NOTE: The SAT may be relocated to sense and control ducted heat.

- LEGEND
- Counterclockwise
  - Common
  - Clockwise
  - Damper Position
  - Ground
  - Hot Water Valve
  - Indoor Air Quality
  - Primary Air Temperature Sensor
  - Relative Humidity
  - Supply Air Temperature Sensor
  - Space Temperature Sensor
  - Field-Supplied Wiring
  - Factory Wiring

→ Fig. 7 — VWT@ Zone Controller Wiring — Single Duct Modulating Hot Water Heat





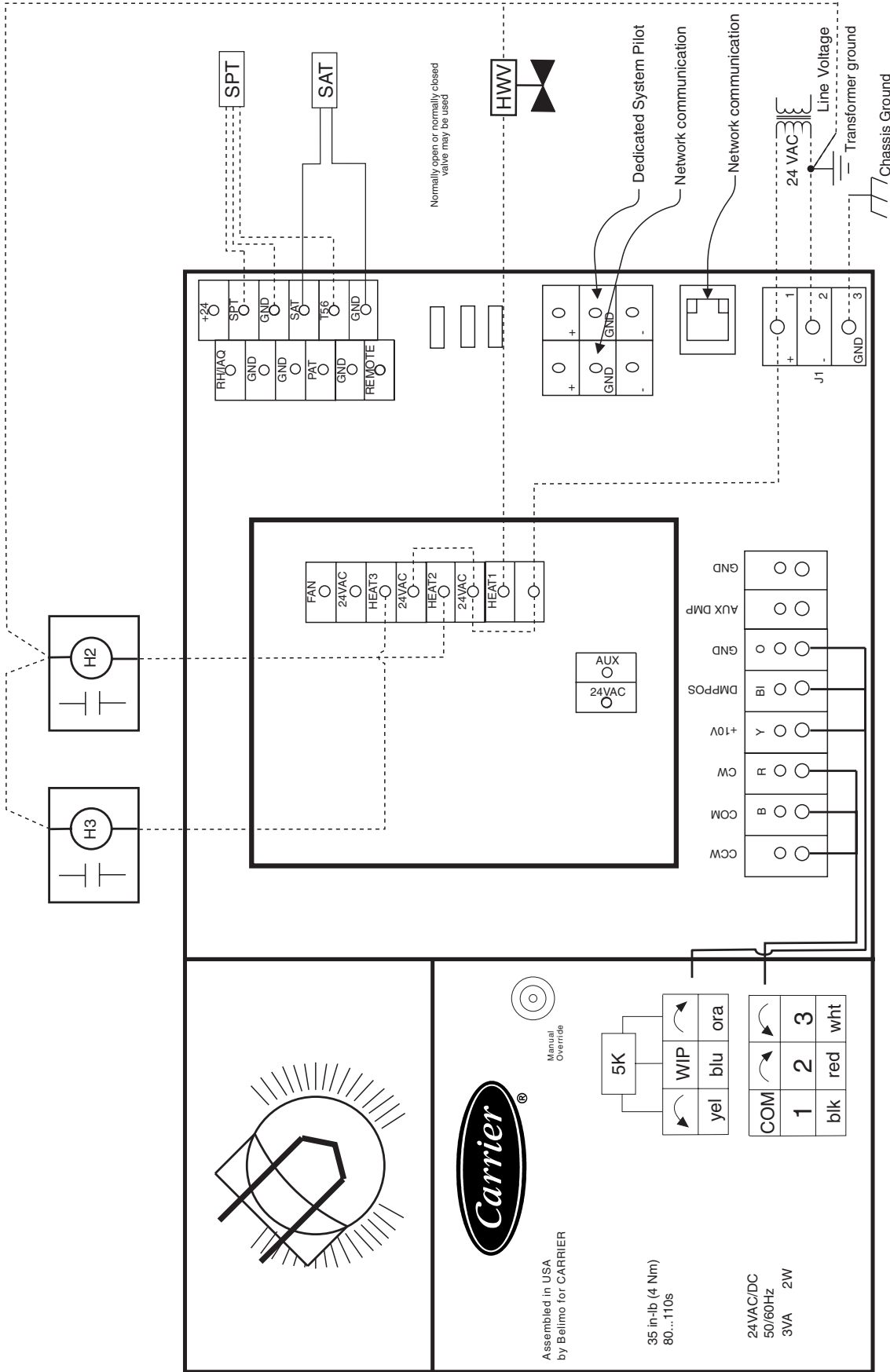

- LEGEND**
- CCW — Counterclockwise
  - COM — Common
  - CW — Clockwise
  - DMPPOS — Damper Position
  - GND — Ground
  - HWV — Hot Water Valve
  - IAQ — Indoor Air Quality
  - PAT — Primary Air Temperature Sensor
  - RH — Relative Humidity
  - SAT — Supply Air Temperature Sensor
  - SPT — Space Temperature Sensor
  - Field-Supplied Wiring
  - Factory Wiring
- NOTE:** The SAT may be relocated to sense and control ducted heat.

→ Fig. 9 — VVT@ Zone Controller Wiring — Single Duct, Combination Base Board, Ducted Heat

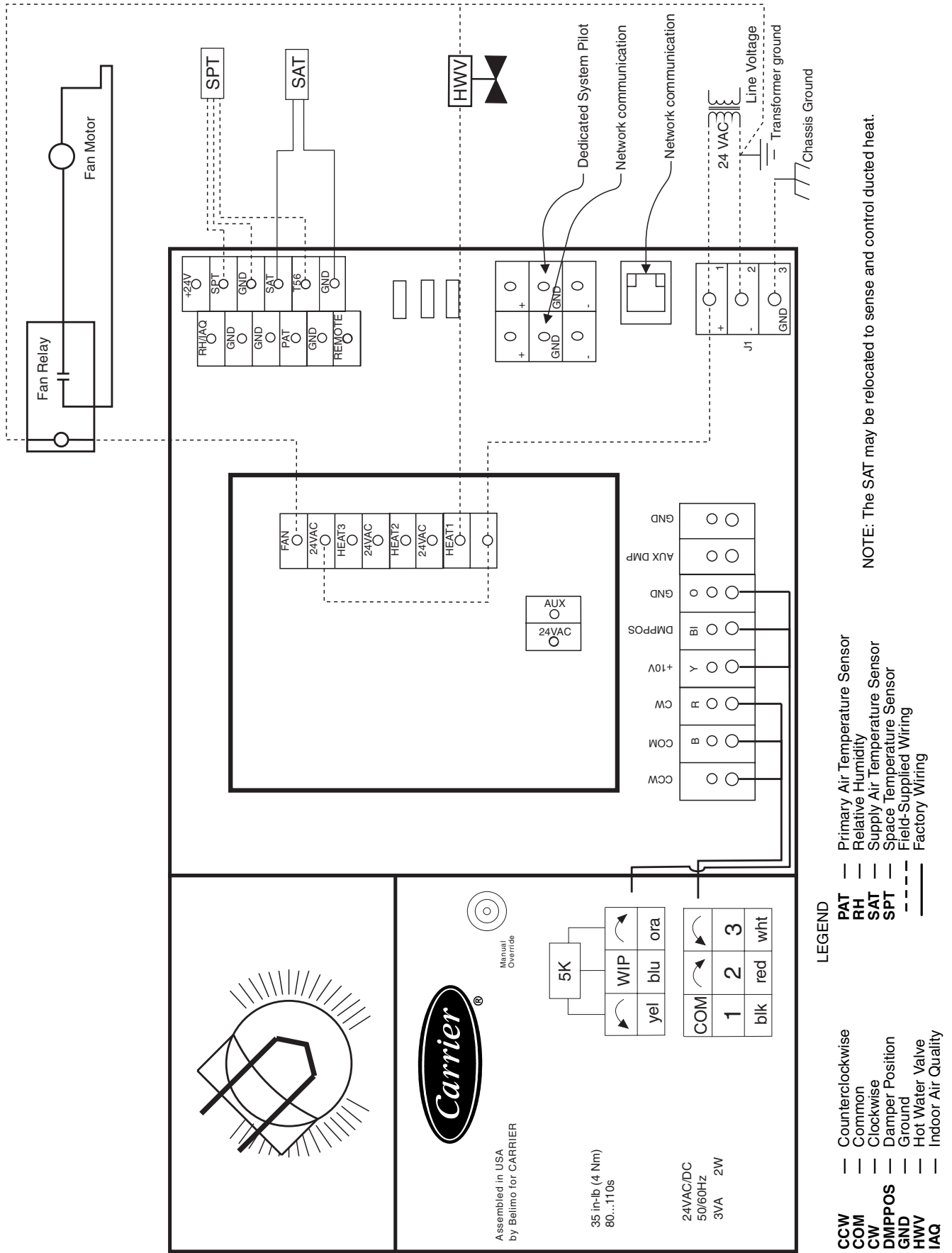

→ Fig. 10 — VVT® Zone Controller Wiring — Fan Box Two-Position Hot Water Heat

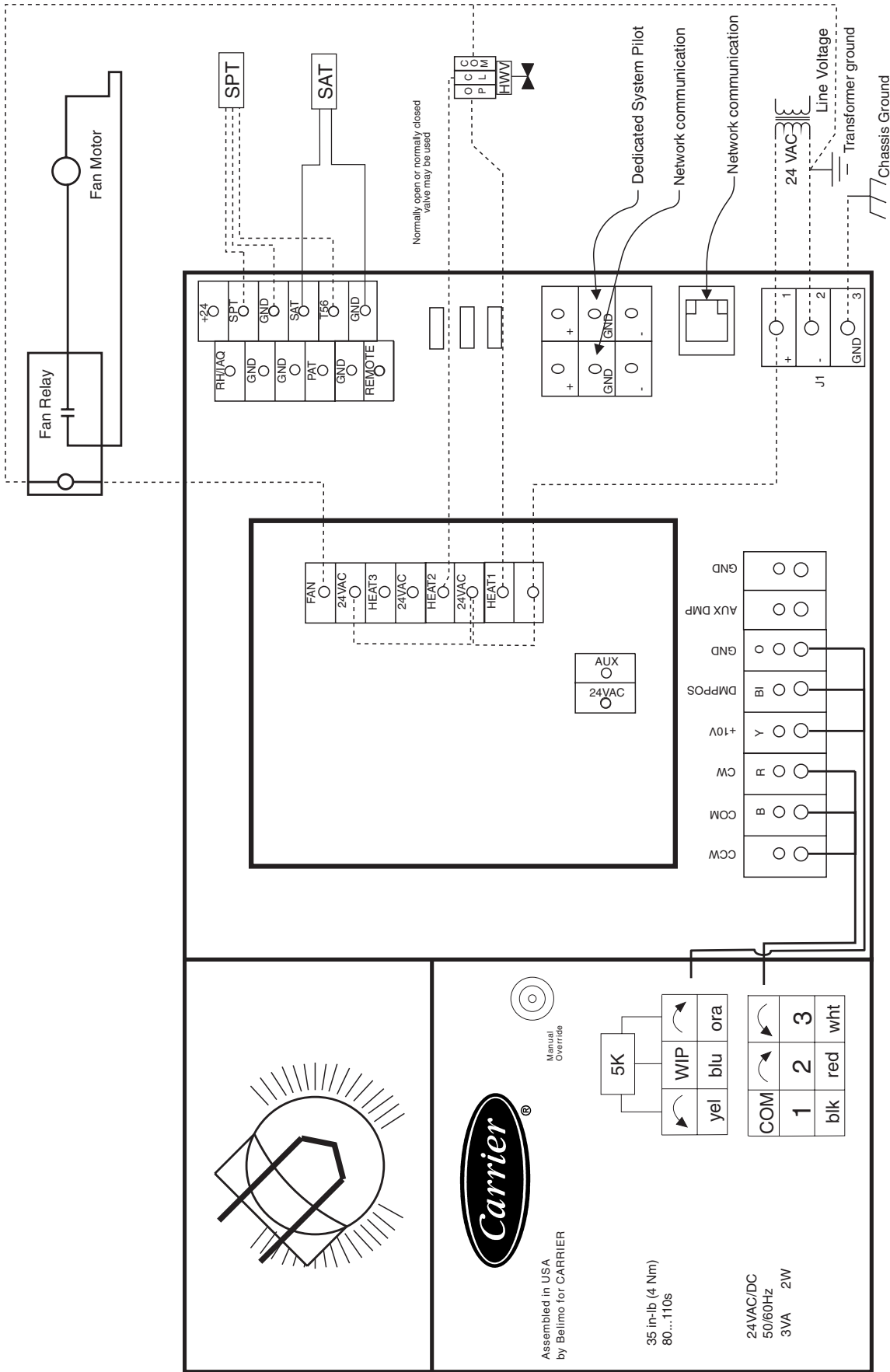

**LEGEND**

CCW — Counterclockwise  
COM — Common  
CW — Clockwise  
DMPPOS — Damper Position  
GND — Ground  
HWV — Hot Water Valve  
IAQ — Indoor Air Quality

PAT — Primary Air Temperature Sensor  
RH — Relative Humidity  
SAT — Supply Air Temperature Sensor  
SPT — Space Temperature Sensor  
--- Field-Supplied Wiring  
--- Factory Wiring

**NOTE:** The SAT may be relocated to sense and control ducted heat.

→ Fig. 11 — VVT® Zone Controller Wiring — Fan Box, Modulating Hot Water Heat



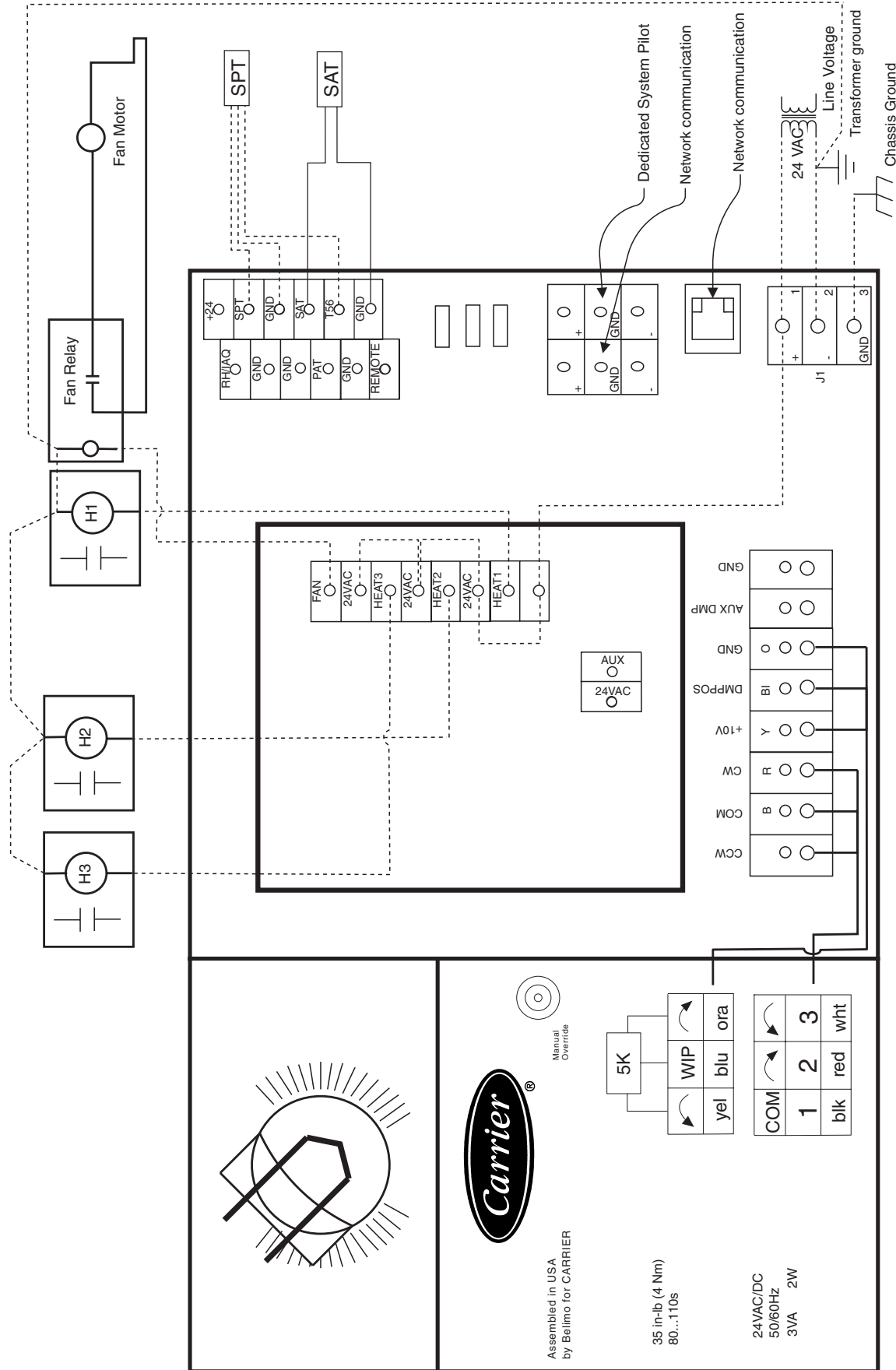

**CCW** — Counterclockwise  
**COM** — Common  
**CW** — Clockwise  
**DMPPOS** — Damper Position  
**GND** — Ground  
**IAQ** — Indoor Air Quality

**PAT** — Primary Air Temperature Sensor  
**RH** — Relative Humidity  
**SAT** — Supply Air Temperature Sensor  
**SPT** — Space Temperature Sensor  
 --- Field-Supplied Wiring  
 --- Factory Wiring

**LEGEND**

**NOTE:** The SAT may be relocated to sense and control ducted heat.

→ Fig. 13 — VWT® Zone Controller Wiring — Fan Box, Three-Stage Electric Heat

## Install Sensors

**SPACE TEMPERATURE SENSOR INSTALLATION** — A space temperature sensor must be installed for each zone controller. There are two types of SPT sensors available from Carrier: the 33ZCT55SPT space temperature sensor with timed override button and the 33ZCT56SPT space temperature sensor with timed override button and set point adjustment. See Fig. 14.

The space temperature sensor is used to measure the building interior temperature and should be located on an interior building wall. The sensor wall plate accommodates the NEMA standard 2 x 4 junction box. The sensor can be mounted directly on the wall surface if acceptable by local codes.

Do not mount the sensor in drafty locations such as near air conditioning or heating ducts, over heat sources such as baseboard heaters, radiators, or directly above wall mounted lighting dimmers. Do not mount the sensor near a window which may be opened, near a wall corner, or a door. Sensors mounted in these areas will have inaccurate and erratic sensor readings.

The sensor should be mounted approximately 5 ft from the floor, in an area representing the average temperature in the space. Allow at least 4 ft between the sensor and any corner and mount the sensor at least 2 ft from an open doorway.

Install the sensor as follows (see Fig. 15):

1. Locate the two Allen type screws at the bottom of the sensor.
2. Turn the two screws clockwise to release the cover from the sensor wall mounting plate.
3. Lift the cover from the bottom and then release it from the top fasteners.
4. Feed the wires from the electrical box through the opening in the center of the sensor mounting plate.
5. Using two no. 6-32 x 1 mounting screws (provided with the sensor), secure the sensor to the electrical box.
6. Use 20 gage wire to connect the sensor to the controller. The wire is suitable for distances of up to 500 ft. Use a three-conductor shielded cable for the sensor and set point adjustment connections. The standard Carrier Network communication cable may be used. If the set point adjustment (slidebar) is not required, then an unshielded, 18 or 20 gage, two-conductor, twisted pair cable may be used.
7. Replace the cover by inserting the cover at the top of the mounting plate first, then swing the cover down over the lower portion. Rotate the two Allen head screws counter-clockwise until the cover is secured to the mounting plate and locked in position.
8. For more sensor information, see Table 1 for thermistor resistance vs temperature values.

**NOTE:** Clean sensor with damp cloth only. Do not use solvents.

**Wiring the Space Temperature Sensor (33ZCT55SPT and 33ZCT56SPT)** — To wire the sensor, perform the following (see Fig. 16 and 17):

1. Identify which cable is for the sensor wiring.
2. Strip back the jacket from the cables for at least 3-inches. Strip  $\frac{1}{4}$ -in. of insulation from each conductor. Cut the shield and drain wire from the sensor end of the cable.

3. Connect the sensor cable as follows:
  - a. Connect one wire from the cable (RED) to the SPT terminal on the controller. Connect the other end of the wire to the left terminal on the SEN terminal block of the sensor.
  - b. Connect another wire from the cable (BLACK) to the GND terminal on the controller. Connect the other end of the wire to the remaining open terminal on the SEN terminal block.

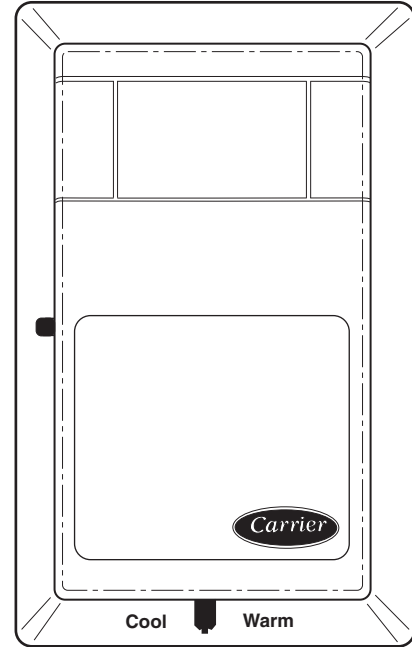

**Fig. 14 — Space Temperature Sensor (P/N 33ZCT56SPT Shown)**

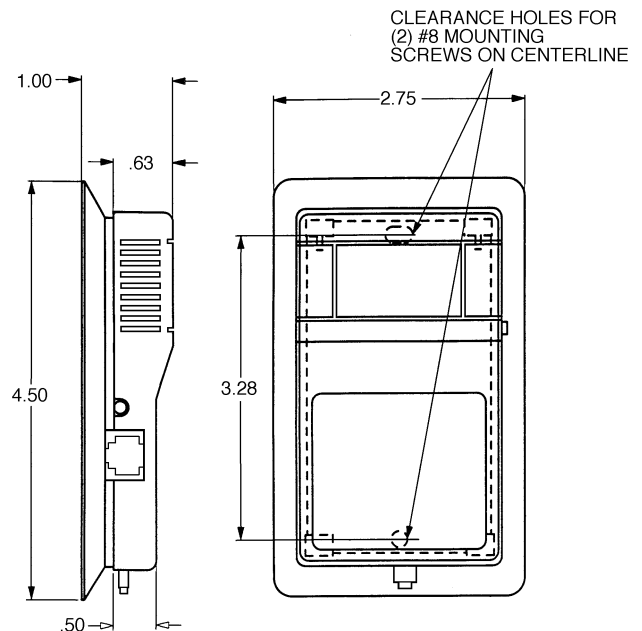

**NOTE:** Dimensions are in inches.

**Fig. 15 — Space Temperature Sensor and Wall Mounted Humidity Sensor Mounting**

- c. On 33ZCT56SPT thermostats, connect the remaining wire (WHITE/CLR) to the T56 terminal on the controller. Connect the other end of the wire to the right most terminal on the SET terminal block.
- d. In the control box, install a No. 6 ring type crimp lug on the shield drain wire. Install this lug under the mounting screw in the upper right corner of the controller (just above terminal T1).
- e. On 33ZCT56SPT thermostats install a jumper between the two center terminals (right SEN and left SET).

**Wiring the Network Communication Service Jack** — See Fig. 16-18. To wire the service jack, perform the following:

1. Strip back the jacket from the communication cable(s) for at least 3 inches. Strip 1/4-in. of insulation from each conductor. Remove the shield and separate the drain wire from the cable. Twist together all the shield drain wires and fasten them together using an closed end crimp lug or a wire nut. Tape off any exposed bare wire to prevent shorting.
2. Connect the CCN + signal wire(s) (RED) to Terminal 5.

3. Connect the CCN – signal wire(s) (BLACK) to Terminal 2.
4. Connect the CCN GND signal wire(s) (WHITE/CLR) to Terminal 4.

Before wiring the Carrier proprietary network connection, refer to the Connect the Carrier Communicating Network Communication Bus section on page 23, for communication bus wiring and cable selection. The cable selected must be identical to the communication bus wire used for the entire network.

The other end of the communication bus cable must be connected to the remainder of the communication bus. If the cable is installed as a T-tap into the bus, the cable length cannot exceed 100 ft. Wire the service jack of the sensor in a daisy chain arrangement with other equipment. Refer to the Connect the Carrier Communicating Network Communication Bus section, page 23, for more details.

**SYSTEM PILOT** — Refer to System Pilot installation instructions for information on installing and using the System Pilot.

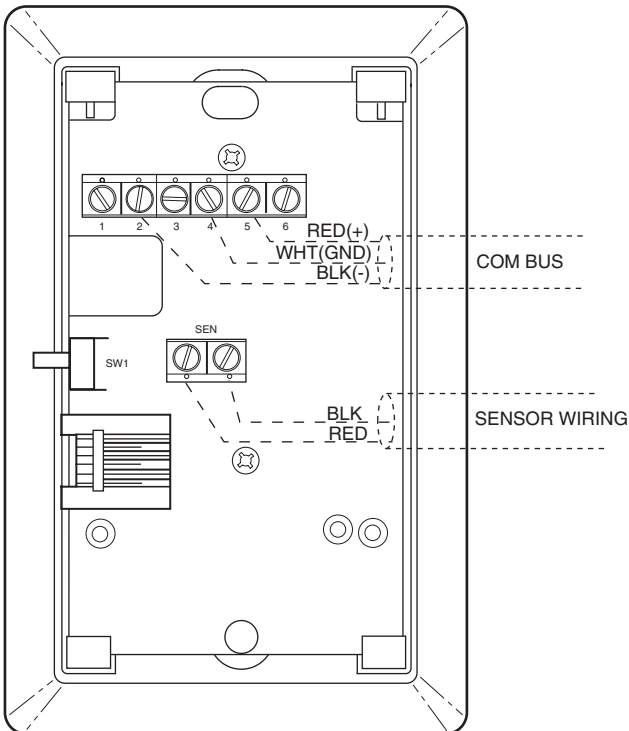

**Fig. 16 — Space Temperature Sensor Wiring (33ZCT55SPT)**

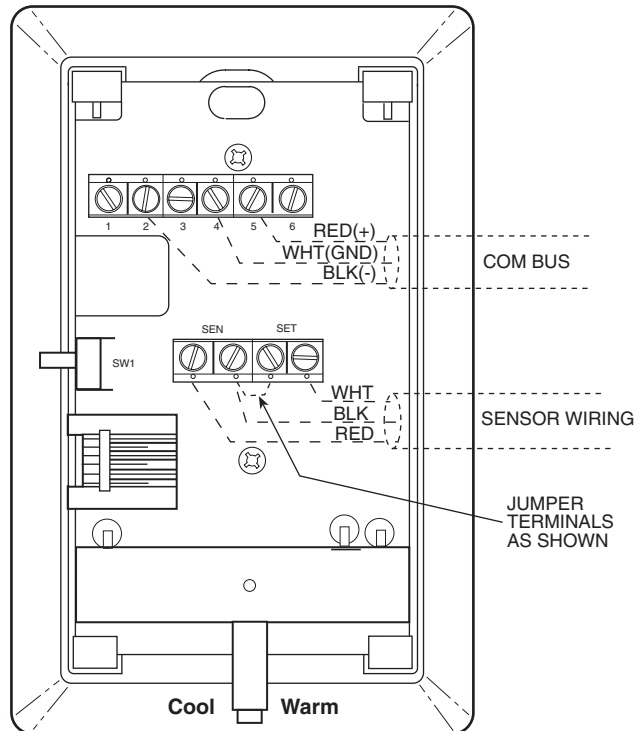

**Fig. 17 — Space Temperature Sensor Wiring (33ZCT56SPT)**



Wiring when distance between zone controller and space temperature sensor is 100 feet or less

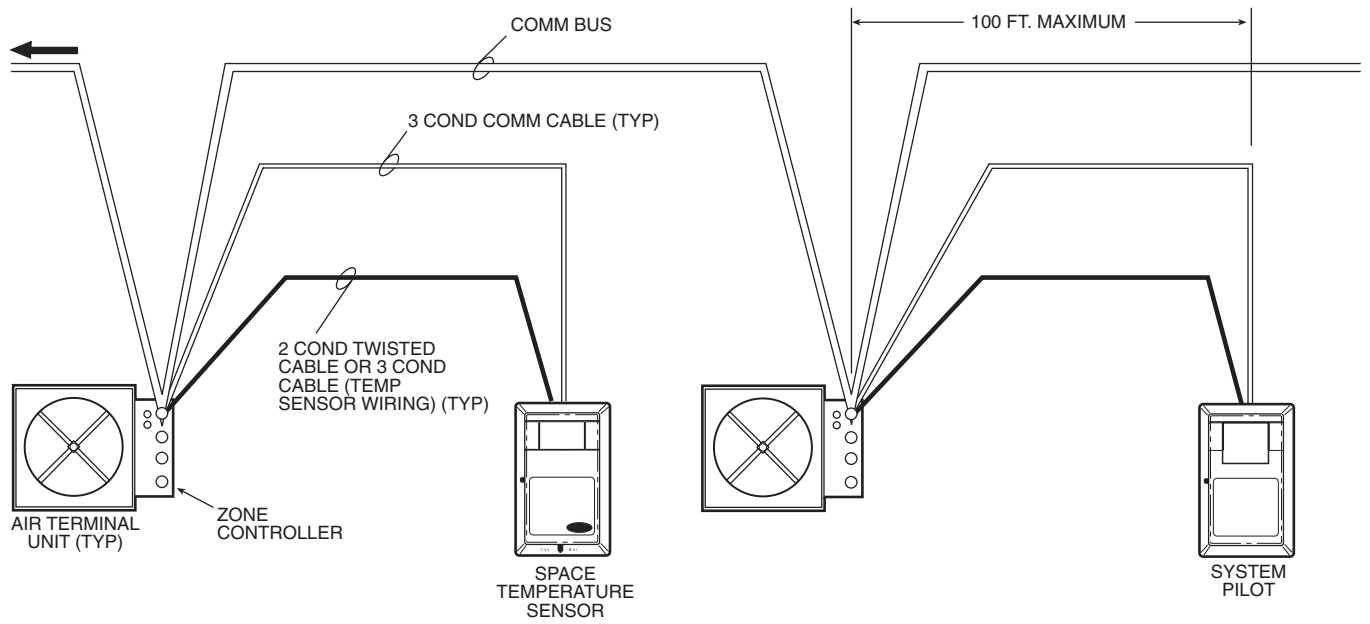

Wiring when distance between zone controller and space temperature sensor is greater than 100 feet

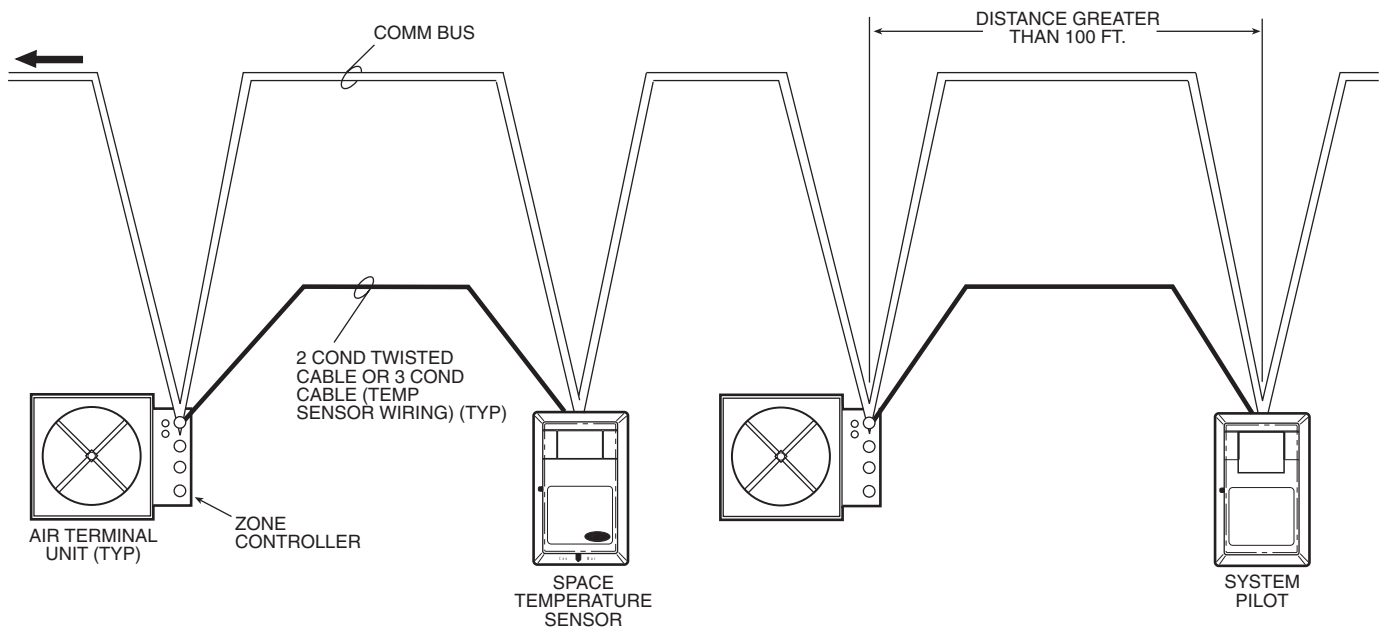

**Fig. 18 — Communication Bus Wiring to Zone Controller**

**Table 1 — Thermistor Resistance vs Temperature Values for Space Temperature Sensor, Return-Air Temperature Sensor, and Supply-Air Temperature Sensor**

TEMP (C)	TEMP (F)	RESISTANCE (Ohms)
-40	-40	335,651
-35	-31	242,195
-30	-22	176,683
-25	-13	130,243
-20	-4	96,974
-15	5	72,895
-10	14	55,298
-5	23	42,315
0	32	32,651
5	41	25,395
10	50	19,903
15	59	15,714
20	68	12,494
25	77	10,000
30	86	8,056
35	95	6,530
40	104	5,325
45	113	4,367
50	122	3,601
55	131	2,985
60	140	2,487
65	149	2,082
70	158	1,752

**PRIMARY AIR TEMPERATURE SENSOR INSTALLATION** — A primary air temperature (PAT) sensor is used on a zone controller which is functioning as a Linkage Coordinator for a non Carrier Network/Linkage compatible air source. The part number is 33ZCSENPAT. See Fig. 19.

When used on a zone controller, try to select a zone controller which will allow installation of the PAT sensor in the main trunk, as close to the air source as possible. See Fig. 20.

**DUCT TEMPERATURE SENSOR (33ZCSENDAT) INSTALLATION** — The 33ZCSENDAT Duct Air Temperature Sensor is required for cooling only applications on non-Carrier dampers. The sensor is used for supply air monitoring. The sensor has an operating range of -40 to 245 F (-40 to 118 C) and includes a mounting grommet and 75-in. cable. The duct temperature sensor must be installed in the supply air duct. See Fig. 21 for sensor details.

The duct temperature sensor should be moved to a location which will provide the best sensing of the supply-air temperature during heating and cooling.

For systems using a ducted supply, the duct temperature sensor should be located in the supply duct downstream of the discharge of the air source and before the bypass damper to allow good mixing of the supply airstream.

The 33ZCSENDAT duct sensor is a small epoxy sensor that is 1¼-in. long. A grommet is provided for filling the hole around the sensor cable after the sensor is located in the duct.

See Fig. 22 for mounting location.

**⚠ WARNING**

Disconnect electrical power before wiring the bypass controller. Electrical shock, personal injury, or damage to the fan coil controller can result.

Do not run sensor or relay wires in the same conduit or raceway with Class 1 AC service wiring. Do not abrade, cut, or nick the outer jacket of the cable. Do not pull or draw cable with a force that may harm the physical or electrical properties. Avoid splices in any control wiring.

Perform the following steps to connect the duct temperature sensor to the bypass controller:

1. Drill or punch a ¼-in. hole in the supply duct. See Fig. 22. Duct sensor can be installed to hang from top of duct or from the sides. Sensor probe can touch side of duct.

2. Push sensor through hole in the supply duct. Snap the grommet into the hole until it is secure. Pull on the leads of the duct sensor until the sensor is snug against the grommet.
3. Connect the sensor leads to the bypass controller's terminal board at the terminals labeled SAT and GND. See Fig. 5-13 for wiring. If extending cable length beyond 8 ft, use plenum rated, 20 AWG (American Wire Gauge), twisted pair wire. Sensor wiring does not have polarity. Either lead can be wired to either terminal.
4. Neatly bundle and secure excess wire.
5. Using electrical tape, insulate any exposed lead to prevent shorting.
6. Connect shield to earth ground (if shielded wire is used).

**SUPPLY AIR TEMPERATURE (33ZCSENSAT) SENSOR INSTALLATION** — The 33ZCSENSAT supply air temperature sensor is required for reheat applications or stand-alone operation. The sensor has an operating range of -40 to 245 F (-40 to 118 C) and includes a 6-in. stainless steel probe and cable. The sensor is factory-supplied but must be relocated for ducted heat. The SAT must be installed in the duct downstream from the air terminal. The SAT sensor is also sometimes called a duct air temperature sensor. Part number 33ZCSENSAT may be used in place of the factory-installed sensor.

The SAT sensor probe is 6 inches in length. The tip of the probe must not touch the inside of the duct. Use field-supplied bushings as spacers when mounting the probe in a duct that is 6 in. or less in diameter.

If the unit is a cooling only unit, the SAT is not required.

If the unit is equipped with electric reheat, ensure that the sensor is installed at least 2 ft downstream of the electric heater. See Fig. 23 for the sensor location in this application.

If the unit has an octopus connected directly at the discharge, install the sensor in the octopus. If the unit has an electric heater, the two-foot minimum distance between the sensor and the heater must be maintained. See Fig. 23 for the sensor location in this application.

**⚠ WARNING**

Disconnect electrical power before wiring the zone controller. Electrical shock, personal injury, or damage to the zone controller can result.

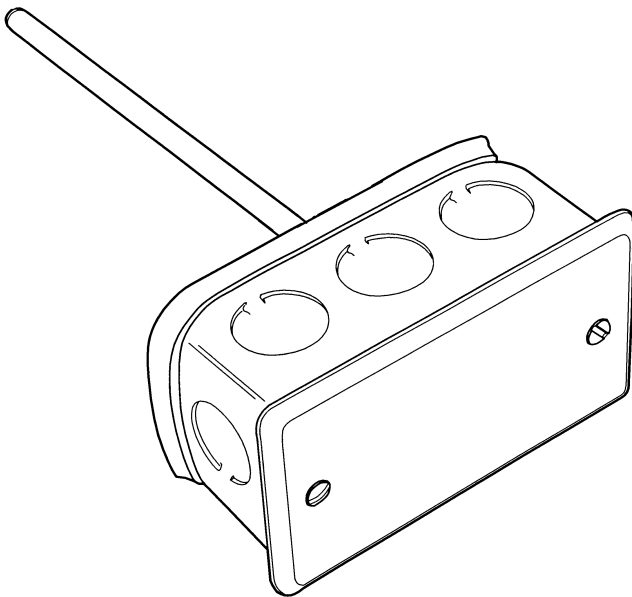

**Fig. 19 — Primary Air Temperature Sensor  
(Part Number 33ZCSENPAT)**

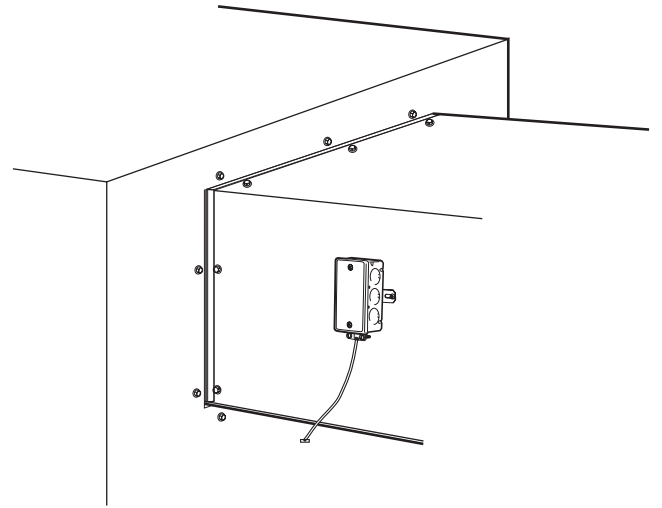

**Fig. 20 — Primary Air Temperature Sensor  
Installation (Unit Discharge Location)**

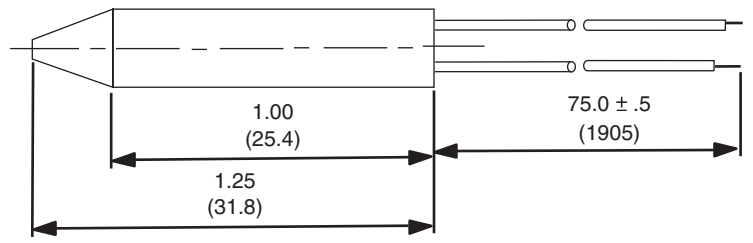
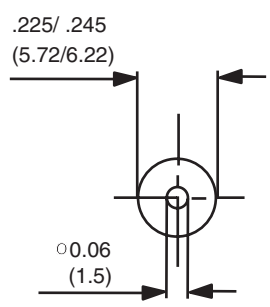

NOTE: Dimensions are in inches (millimeters).

**Fig. 21 — 33ZCSENSDAT Duct Sensor**

Do not run sensor or relay wires in the same conduit or raceway with Class 1 AC or DC service wiring. Do not abrade, cut, or nick the outer jacket of the cable. Do not pull or draw cable with a force that may harm the physical or electrical properties. Avoid splices in any control wiring.

Perform the following steps to connect the SAT sensor to the zone controller:

1. Locate the opening in the control box. Pass the sensor probe through the hole.
2. Drill or punch a 1/4-in. hole in the duct *downstream* of the unit, at a location that conforms to the requirements shown in Fig. 23.
3. Use two field-supplied, self-drilling screws to secure the sensor probe to the duct. Use field-supplied bushings as spacers when installing the sensor probe in a duct 6 in. or less in diameter.

Perform the following steps if state or local code requires the use of conduit, or if your installation requires a cable length of more than 8 ft:

1. Remove the center knockout from a field-supplied 4 x 2-in. junction box and secure the junction box to the duct at the location selected for the sensor probe.
2. Drill a 1/2-in. hole in the duct through the opening in the junction box.
3. Connect a 1/2-in. nominal field-supplied conduit between the zone controller enclosure and the junction box.
4. Pass the sensor probe wires through the conduit and insert the probe in the duct. Use field-supplied bushings as spacers when installing the sensor probe in a duct 6 in. or less in diameter.
5. Secure the probe to the duct with two field-supplied self-drilling screws.
6. If extending cable length beyond 8 ft, use plenum rated, 20 AWG (American Wire Gauge), twisted pair wire.
7. Connect the sensor leads to the zone controller's wiring harness terminal board at the terminals labeled SAT and GND.
8. Neatly bundle and secure excess wire.

**INDOOR AIR QUALITY SENSOR INSTALLATION —**

The indoor air quality (IAQ) sensor accessory monitors carbon dioxide levels. This information is used to modify the position of the outdoor air dampers to admit more outdoor air as required to provide the desired ventilation rate. Two types of sensors are supplied. The wall sensor can be used to monitor the conditioned air space; the duct sensor monitors the return air duct. Both wall and duct sensors use infrared technology to measure the levels of CO<sub>2</sub> present in the air. The wall sensor is available with or without an LCD (liquid crystal display) readout to display the CO<sub>2</sub> level in ppm. See Fig. 24.

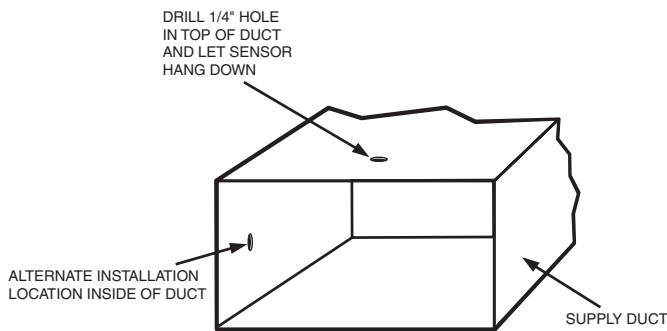

**Fig. 22 — DAT Installation Location**

The sensor part number is 33ZCSENCO2. To mount the sensor, refer to the installation instructions shipped with the accessory kit.

The CO<sub>2</sub> sensors (33ZCSENCO2) factory set for a range of 0 to 2000 ppm and a linear voltage output of 0 to 10 vdc. Figure 25 shows ventilation rates for various CO<sub>2</sub> set points when outside air with a typical CO<sub>2</sub> level of 350 ppm is used. Refer to the instructions supplied with the CO<sub>2</sub> sensor for electrical requirements and terminal locations. The zone controller requires a 24 vac, 25 va transformer to provide power to the sensor.

To convert the CO<sub>2</sub> sensor into a duct-mounted CO<sub>2</sub> sensor, the duct-mounted aspirator (33ZCASPCO2) will need to be purchased.

To accurately monitor the quality of the air in the conditioned air space, locate the sensor near the return air grille so it senses the concentration of CO<sub>2</sub> leaving the space. The sensor should be mounted in a location to avoid direct breath contact.

Do not mount the space sensor in drafty areas such as near supply ducts, open windows, fans, or over heat sources. Allow at least 3 ft between the sensor and any corner. Avoid mounting the sensor where it is influenced by the supply air; the sensor gives inaccurate readings if the supply air is blown directly onto the sensor or if the supply air does not have a chance to mix with the room air before it is drawn into the return air stream.

To accurately monitor the quality of the air in the return air duct, locate the sensor at least 6 in. upstream or 15 in. downstream of a 90-degree turn in the duct. The downstream location is preferred. Mount the sensor in the center of the duct.

**IMPORTANT:** If the sensor is mounted in the return-air duct, readjust the mixed-air dampers to allow a small amount of air to flow past the return-air damper whenever the mixing box is fully open to the outside air. If the damper is not properly adjusted to provide this minimum airflow, the sensor may not detect the indoor-air quality during the economizer cycle.

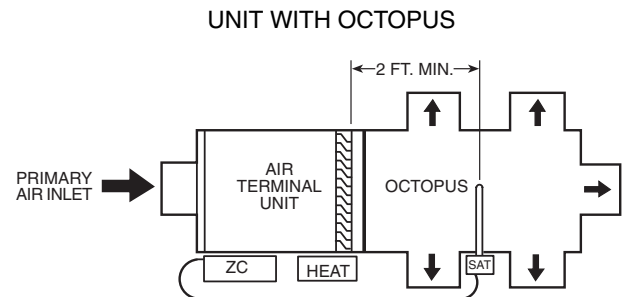
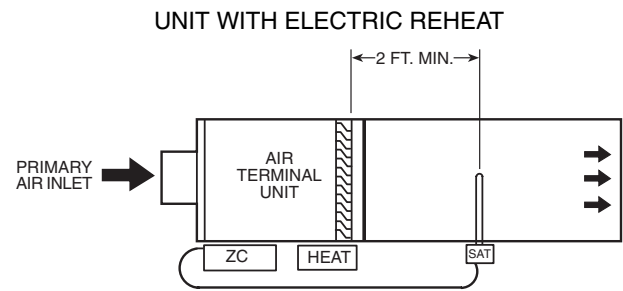

ZC — Zone Controller

**Fig. 23 — Supply Air Temperature Probe (Part No. 33ZCSENSAT) Locations**

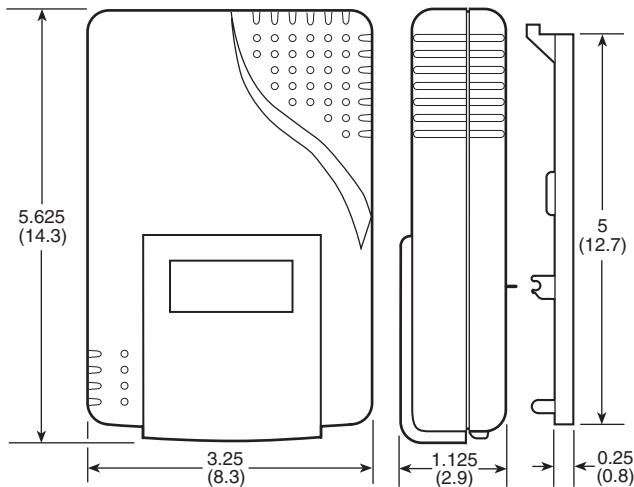

NOTE: Dimensions are in inches. Dimensions in ( ) are in millimeters.

**Fig. 24 — Indoor Air Quality (CO<sub>2</sub>) Sensor (33ZCSENCO2)**

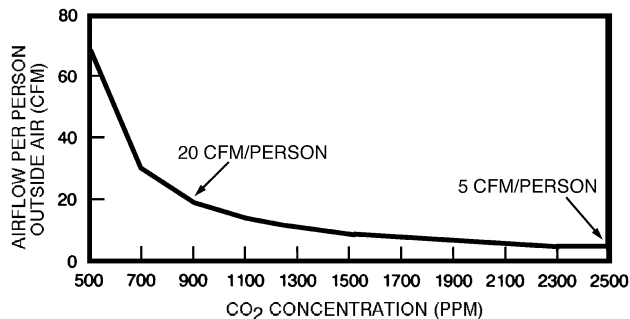

**Fig. 25 — Ventilation Rated Based on CO<sub>2</sub> Set Point**

**Indoor Air Quality Sensor Wiring** — To wire the sensors after they are mounted in the conditioned air space and return air duct, see Fig. 26 and the instructions shipped with the sensors. For each sensor, use two 2-conductor 18 AWG twisted-pair cables (unshielded) to connect the separate isolated 24 vac power source to the sensor and to connect the sensor to the control board terminals. To connect the sensor to the control board, identify the positive (+) PIN-8 and ground (GND) PIN-7 terminals on the sensor and connect the positive terminal to terminal RH/IAQ and connect the ground terminal to terminal GND.

**HUMIDITY SENSOR (WALL-MOUNTED) INSTALLATION** — The accessory space humidity sensor is installed on an interior wall to measure the relative humidity of the air within the occupied space. See Fig. 27.

The use of a standard 2 x 4-in. electrical box to accommodate the wiring is recommended for installation. The sensor can be mounted directly on the wall, if acceptable by local codes.

If the sensor is installed directly on a wall surface, install the humidity sensor using 2 screws and 2 hollow wall anchors (field-supplied); *do not overtighten screws*. See Fig. 15.

**⚠ CAUTION**

Do NOT clean or touch the sensing element with chemical solvents; they can permanently damage the sensor.

The sensor must be mounted vertically on the wall. The Carrier logo should be oriented correctly when the sensor is properly mounted.

DO NOT mount the sensor in drafty areas such as near heating or air-conditioning ducts, open windows, fans, or over heat sources such as baseboard heaters, radiators, or wall-mounted light dimmers. Sensors mounted in those areas will produce inaccurate readings.

Avoid corner locations. Allow at least 4 ft between the sensor and any corner. Airflow near corners tends to be reduced, resulting in erratic sensor readings.

Sensor should be vertically mounted approximately 5 ft up from the floor, beside the space temperature sensor.

For distances up to 500 feet, use a 3-conductor, 18 or 20 AWG cable. A communication cable can be used, although the shield is not required. The shield must be removed from the sensor end of the cable if this cable is used. See Fig. 28 for wiring details.

The power for the sensor is provided by the control board. The board provides 24 vdc for the sensor. No additional power source is required.

To wire the sensor, perform the following:

1. At the sensor, remove 4-in. of jacket from the cable. Strip 1/4-in. of insulation from each conductor. Route the cable through the wire clearance opening in the center of the sensor. See Fig. 28.
2. Connect the RED wire to the sensor screw terminal marked (+).
3. Install one lead from the resistor (supplied with the sensor) and the WHITE wire, into the sensor screw terminal marked (-). After tightening the screw terminal, test the connection by pulling gently on the resistor lead.
4. Connect the remaining lead from the resistor to the BLACK wire and secure using a closed end type crimp connector or wire nut.
5. Using electrical tape, insulate any exposed resistor lead to prevent shorting.
6. At the control box, remove the jacket from the cable and route the RED conductor over to the left side of the control board. Route the remaining conductors to the right side of the control board.
7. Strip 1/4-in. of insulation from each conductor and equip each with a 1/4-in. female quick connect terminal.
8. Connect the RED wire to terminal +24v on the control board.
9. Connect the BLACK wire to terminal GND on the control board.
10. Connect the WHITE/CLEAR wire to terminal RH/IAQ on the control board.
11. Connect shield to ground (if shielded wire is used).

**Remote Occupancy Contact** — The remote occupancy input (J4 pin 1) has the capability to be connected to a normally open or normally closed occupancy dry contact. Wire the dry contact as show in Fig. 29 between J4 Pin 1 and 24 VAC J1 Pin 1. The 24 vac necessary to supply the VVT® zone controller remote occupancy contact input is supplied using the zone controller.

**Connect the Outputs** — Wire the zone controller's outputs (fan, staged heat, valves) as shown in the applicable wiring diagrams in Fig. 5-13.

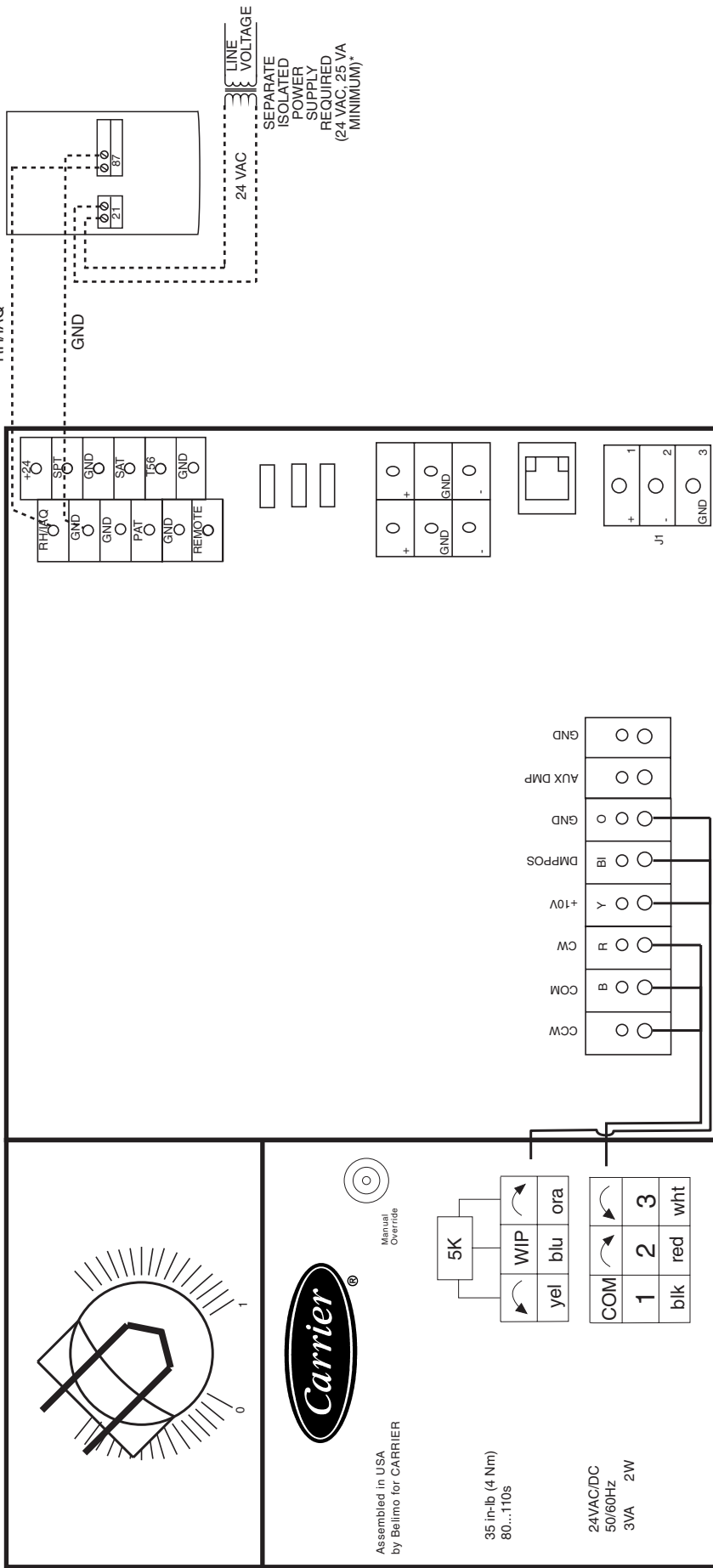
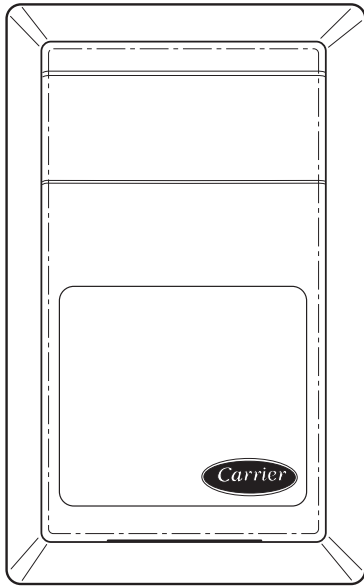

Fig. 26 — Indoor Air Quality Sensor Wiring

\*Do not connect to the same transformer that supplies power to the zone controller.



**Fig. 27 — Wall Mounted Relative Humidity Sensor**

**Modulating Baseboard Hydronic Heating** — Install the water valve on the leaving water end of the baseboard heater. See Fig. 30. Observe the fluid flow direction when mounting the valve. Be sure to properly heat sink the valve and direct the flame away from the actuator and valve body when sweating the valve connections. Install the leaving water temperature sensor (33ZCSENGH) on the hydronic heating coil as shown. The sensor accommodates nominal copper pipe from 1/2 to 1-in. (OD sizes from 5/8 to 1.125 in.). It should be secured to the pipe with the clamp supplied. If piping is larger than 1-in. nominal size, a field-supplied clamp must be used. Use fiberglass pipe insulation to insulate the sensor assembly.

Refer to Fig. 7 and 11 to wire the modulating water valve and the sensor to the zone controller. Connect the leaving water temperature sensor to the controller using the wiring connections shown for the SAT sensor. (NOTE: The leaving water temperature sensor replaces the SAT sensor in this application.) Use 18 or 20 AWG wire for all connections. The water valve actuator housing may be used as a junction box if the leaving water temperature sensor cable is not long enough and the sensor cable must be extended to reach the controller.

For modulating hydronic heating applications, the default configuration must be changed to properly control the valve. Refer to the service configuration table and set the Heating Loop parameters as follows:

Proportional Gain = 20.0  
 Integral Gain = 0.5  
 Derivative Gain = 0.0  
 Start Value = 102.0

Also, set the Ducted Heat decision to YES and set the Maximum Duct Temperature decision equal to the design (maximum) boiler water temperature minus 20 degrees, but not greater than 200 F.

→ **Connect the Carrier Communicating Network Communication Bus** — The zone controllers connect to the bus in a daisy chain arrangement. The zone controller may be installed on a primary bus or on a secondary bus from the primary bus. Connecting to a secondary bus is recommended.

At 9,600 baud, the number of controllers is limited to 128 zones maximum, with a limit of 8 systems (Linkage Coordinator configured for at least 2 zones). Bus length may not

exceed 4000 ft, with no more than 60 devices on any 1000-ft section. Optically isolated RS-485 repeaters are required every 1000 ft.

At 19,200 and 38,400 baud, the number of controllers is limited to 128 maximum, with no limit on the number of Linkage Coordinators. Bus length may not exceed 1000 ft.

On larger systems with more than 8 linkage coordinators, use bridges to split the system into sections. The first zone controller in a network connects directly to the bridge and the others are wired sequentially in a daisy chain fashion. Refer to Fig. 31 for an illustration of Communication Bus wiring.

The Communication Bus also connects to the zone controller space temperature sensor. Refer to the Install the Sensors section for sensor wiring instructions.

**COMMUNICATION BUS WIRE SPECIFICATIONS** — The Communication Bus wiring is field-supplied and field-installed. It consists of shielded three-conductor cable with drain (ground) wire. The cable selected must be identical to the Communication Bus wire used for the entire network. See Table 2 for recommended cable.

**Table 2 — Recommended Cables**

MANUFACTURER	CABLE PART NO.
Alpha	2413 or 5463
American	A22503
Belden	8772
Columbia	02525

NOTE: Conductors and drain wire must be at least 20 AWG (American Wire Gage), stranded, and tinned copper. Individual conductors must be insulated with PVC, PVC/nylon, vinyl, Teflon, or polyethylene. An aluminum/polyester 100% foil shield and an outer jacket of PVC, PVC/nylon, chrome vinyl, or Teflon with a minimum operating temperature range of -20 C to 60 C is required.

**CONNECTION TO THE COMMUNICATION BUS**

- Strip the ends of the red, white, and black conductors of the communication bus cable.
- Connect one end of the communication bus cable to the bridge communication port labeled COMM2 (if connecting on a secondary bus).

When connecting the communication bus cable, a color code system for the entire network is recommended to simplify installation and checkout. See Table 3 for the recommended color code.

- Connect the other end of the communication bus cable to the terminal block labeled J2A in the zone controller of the first air terminal. Following the color code in Table 3, connect the Red (+) wire to Terminal 1. Connect the White (ground) wire to Terminal 2. Connect the Black (-) wire to Terminal 3.
- Connect additional zone controllers in a daisy chain fashion, following the color coded wiring scheme in Table 3. Refer to Fig. 31.

NOTE: The communication bus drain wires (shield) must be tied together at each zone controller. If the communication bus is entirely within one building, the resulting continuous shield must be connected to ground at only one single point. If the communication bus cable exits from one building and enters another building, connect the shields to ground at a lightning suppressor in each building where the cable enters or exits (one point only).

**Table 3 — Color Code Recommendations**

SIGNAL TYPE	COMMUNICATION BUS WIRE COLOR	PLUG PIN NUMBER
+	Red	1
Ground	White	2
-	Black	3





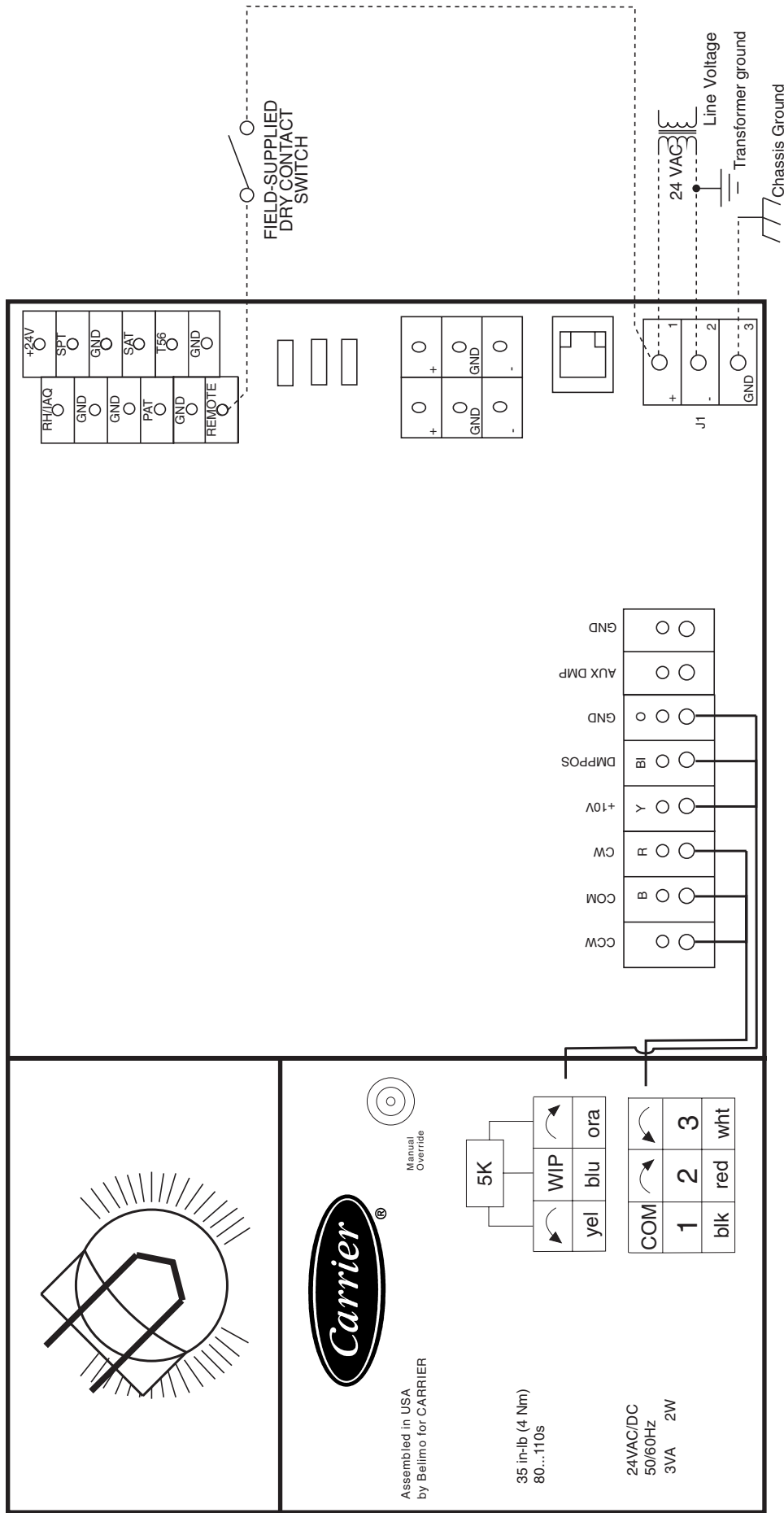
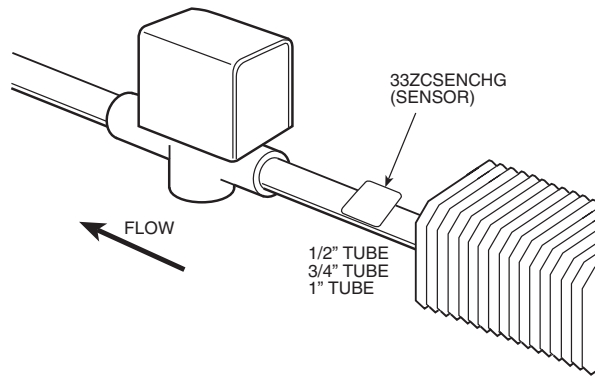
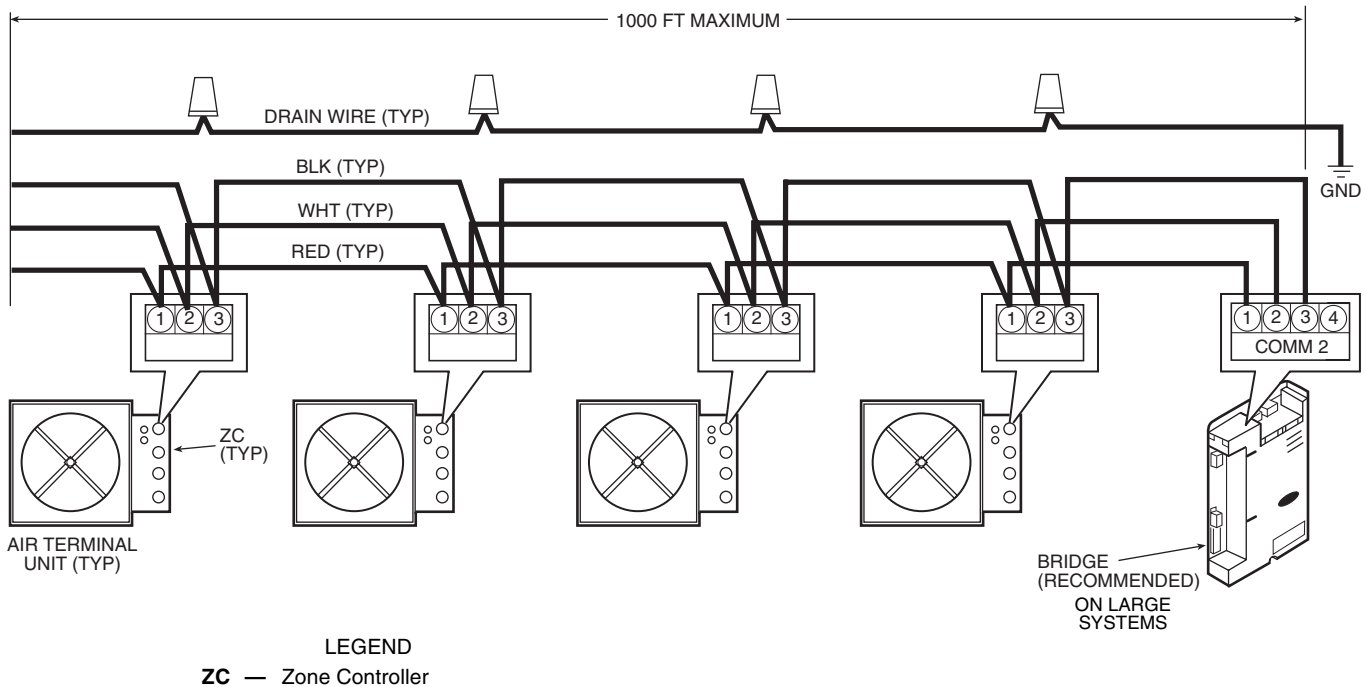

Fig. 29 — Remote Occupancy Wiring



**Fig. 30 — Typical Water Valve and Sensor Installation**



**→ Fig. 31 — Communication Bus Wiring**

## START-UP

Use the Carrier network communication software to start up and configure the zone controller.

All set-up and set point configurations are factory-set and field-adjustable.

Changes can be made using the System Pilot or Carrier software. During start-up, the Carrier software can also be used to verify communication with each zone controller.

For specific operating instructions, refer to the literature provided with the software.

### Perform System Checkout

1. Check correctness and tightness of all power and communication connections.
2. Check that all air terminals, ductwork, and zone controllers are properly installed and set according to installation instructions and job requirements.

3. Check that all air duct connections are tight.
4. At the air terminals, check fan and system controls for proper operation. Verify that actuator screws are properly tightened.
5. At the air terminals, check electrical system and connections of any optional electric reheat coil. If hot water reheat is used, check piping and valves against job drawings.
6. At the air terminals, make sure that all balancing dampers at box outlets are in the fully open position.
7. If using an air source with field-installed controls, make sure controls and sensors have been installed and wired per manufacturer installation instructions.
8. At air source, verify that the motor starter and, if applicable, the Hand/Off/Auto (HOA) switch are installed and wired.

9. Check to be sure the area around the air source is clear of construction dirt and debris.
10. Check that final filters are installed in the air handler(s). Dust and debris can adversely affect system operation.
11. Verify that the zone controller and the air source controls are properly connected to the communication bus.

### ▲ CAUTION

Before starting the air source fan, make sure that dampers at the system's air terminals are not fully closed. Starting the fan with dampers closed will result in damage to the system ductwork.

12. Remember to utilize good duct design and to provide sufficient straight duct at the inlet of the box. A minimum of three times the inlet size is recommended.

**Network Addressing** — Use the following method when all the zone controllers are installed and powered, and the SPT sensors are wired and functioning properly. This method can be used if no addresses have been set previously. The address of an individual zone controller may be set by using the System Pilot. This is the standard method of setting the address.

Each zone controller will default to an address of 0, 140 when its application software is initially loaded. Since multiple controllers will be on the same bus, a unique address must be assigned to each controller before the system can operate properly. The assignment of controller addresses will be performed through the System Pilot, as follows:

1. The System Pilot recognizes that the Zone Controller's address, stored in the zone controller memory, has not been written yet (this will be true when the unit is first powered up on the job, or after a jumper-initiated reset).
2. Press the override button on the SPT (terminals J4-14 and J4-12 are shorted) for 1 to 10 seconds.
3. The zone controller address changes from 0, 140 to 239, 239 for a period of 15 minutes.
4. Use System Pilot to change the address from 239, 239 to a valid system address within 15 minutes.

**NOTE:** If the address is not changed from 239, 239 to a valid system address within 15 minutes, the controller will revert to address 0, 140 and use of the override button will cause the address function to repeat. The operator **MUST** actively set the address even if the final desired address is 0, 140.

**Initial Operation and Test** — Perform the following procedure:

1. Apply 24 vac power to the control.
2. Using the System Pilot, upload the controller from address assigned in Network Addressing section above.
3. From the Terminal Service Configuration screen, properly configure the damper type and inlet size. If a round inlet is used, then enter the size directly in the Inlet Diameter decision. If a square, rectangular, or elliptical damper inlet is supplied, then enter the inlet size in square inches in the Inlet Area decision.
4. If the terminal damper closes in the CW direction, then no adjustment is required. Otherwise, locate the damper direction configuration decision (CW Rotation) and toggle the value to OPEN by using the space bar. This configuration decision is also located on the Terminal Service Configuration screen.
5. After entering the area and rotation direction, verify operation of the damper. From the System Pilot Diagnostic,

Maintenance Screen, select the Zone Commissioning Table and force the Commissioning Mode point to Enable. Then select the Damper Cal point and force this point to Enable. The controller automatically tests the actuator by fully closing the damper.

It checks the fully closed position to determine if the control was properly mounted. It then opens the damper. The control scales the actual actuator travel range used to a 0 to 100% open value. Finally the control will close the damper, test, and zero the pressure transducer. When completed, the control automatically removes the force from the Damper Cal point. If a failure occurs at any point during the testing, the Damper Calibration Status point at the bottom of the screen will indicate ALARM and the test will be aborted.

6. The actuator stroke has now been calibrated for the proper rotation.

**Fan and Heat Configuration and Test** — Perform the following procedure to configure and test the fan and heat:

1. Display the Terminal Service Configuration screen to make sure the proper Terminal Type and Heat Type are configured. See the Configuration section to answer questions about the individual configurations.
2. From the Diagnostics Maintenance Screen select the Zone Commissioning table.
3. Force the Commissioning Mode to Enable.
4. If the terminal is a parallel or series powered fan box, force the Fan Override to Enable. If the damper is open it may have to be repositioned to the proper position depending on the box type. Damper percent change will be displayed. After the damper is positioned correctly, the fan relay should energize and the fan should run for a few seconds.
5. Make sure the fan runs and the Fan Override decision returns to disabled to ensure the fan is wired correctly for proper operation.
6. Force the Heating Override to Enable. If the unit is a single duct unit, this must be done with the primary terminal at reheat set point. The damper will open to the reheat cfm. The heat outputs will be commanded to provide maximum heat. If the unit is a fan-powered terminal, the fan must be on.

**NOTE:** The damper position settings can be found under service configuration in the table AIRFLOW.

**System Balancing** — To balance the system, perform the following procedure:

1. Enable the balancing process by forcing System Commissioning to Enable.
2. Enable the All Zone Dampers to Max point.
3. The zone controller will send all system zone dampers to their configured maximum positions and display the values. Check the system maximum airflows to all zones and set zone dampers while the system is at maximum flow and the bypass damper is closed. Adjust maximum damper position set points if required. The system can also be balanced at design conditions with some dampers closed.
4. If the user forces any zones to a new position, the new position is written to the zone's maximum damper position configuration value and the damper is repositioned.
5. Enable the All Zone Dampers to Min point.

6. The zone controller will send all system zone dampers to their configured minimum positions and display the values. Check the system bypass pressure and set the pressure set point. Adjust minimum damper set points if required.
7. If the user forces any zones to a new position, the new position is written to the zone's minimum damper position configuration value and the damper is repositioned.
8. Enable the Position Single Zone point.
9. The zone controller will send all system zone dampers to their configured maximum positions and display the values.
10. If the user forces any zones to a new position, the new position is written to the zone's maximum damper position configuration value and the damper is repositioned.
11. At this time, the user can force the Bypass Pressure set point. Typically, the maximum unit rated duct static is used. The zone controller will then write the forced Bypass Pressure set point to the set point table in the Bypass Controller by communicating over the network. The bypass controller will then begin to control to the new bypass pressure set point.

**Status Table** — The following sections describe the computer status screen which is used to determine status the zone controller. The screens shown may be displayed differently when using different Carrier software. See Table 4.

**TERMINAL MODE** — The terminal mode is determined by the equipment mode as reported by linkage and space requirements determined by space temperature and set points. The ZONE\_BAL and COMMISS modes are the result of the activating the commissioning maintenance table to perform terminal testing and commissioning.

Terminal Mode:	Display Units	ASCII
	Default Value	COOL
	Display Range	HEAT, COOL, VENT, REHEAT, PRESSURE, EVAC, OFF, ZONE_BAL, COMMISS
	Network Access	Read only

**TERMINAL TYPE** — Terminal type is the confirmation of the terminal type configuration in the CONFIG Service Config table.

Terminal Type:	Display Units	ASCII
	Default value	SINGLDUCT
	Display Range	SINGLDUCT, PAR FAN, SER FAN
	Network Access	Read only

**CONTROLLING SETPOINT** — Controlling Set Point will display either the heating master reference or the cooling master reference depending upon what mode the terminal is in. The display will default to the heating master reference and display the last controlling master reference when in neither heating nor cooling.

Controlling Setpoint:	Display Units	F (C)
	Default Value	-40
	Display Range	-40 to 245
	Network Access	Read only

→ **SPACE TEMPERATURE** — Space temperature from 10 kΩ thermistor (Type II) located in the space. The point name of the displayed Space Temperature is "SPACE\_T" in this status display table. This point may be forced for diagnostic purposes.

A non-displayed variable named SPT also exists within the zone controller as a writeable point for normal operations with a System Pilot or other devices that will write a space temperature to the zone controller. The zone controller verifies that the SPT point is being written to before using it to update the SPACE\_T point. Values that are received at the SPT point may be averaged with the hardware space temperature input.

Space Temperature:	Display Units	F (C)
	Default Value	-40.0
	Display Range	-40.0 to 245.0
	Network Access	Read/Write

**DAMPER POSITION** — Damper position percent range of rotation determined by the transducer calibration procedure. The zone controller is designed be used on dampers with any range of rotation.

Damper Position:	Display Units	% open
	Default Value	0
	Display Range	0 to 100
	Network Access	Read only

→ **SUPPLY AIR TEMPERATURE** — This reading is the temperature of the air provided by the air source. If ducted heat is present, this sensor may be relocated to measure temperature of the air leaving the zone controller downstream of any ducted heat source. Measured by a 10 kΩ thermistor (Type II). This temperature may be used to control the maximum discharge air to the space when local heat is active. The local SAT Installed configuration is used to enable or disable this sensor.

Supply Air Temperature:	Display Units	F (C)
	Default Value	0.0
	Display Range	-40.0 to 245.0
	Network Access	Read/Write

**LOCAL HEATING CAPACITY** — When local heat at the terminal is enabled the percent of heat being delivered is determined by the following formula for modulating (floating point) type heat:

$$\% \text{ Capacity} = [(SAT - SPT) / (\text{Maximum Duct Temp} - SPT)]$$

The percent of heat delivered is determined by the following for two-position hot water or staged electric heat:

$$\% \text{ Output Capacity} = (\text{no. of active stages} / \text{Total stages}) * 100$$

Local Heating Capacity:	Display Units	% output capacity
	Default Value	0
	Display range	0 to 100
	Network Access	Read only

**TERMINAL FAN** — The commanded output for the terminal fan on a fan powered terminal.

Terminal Fan:	Display Units	Discrete ASCII
	Default Value	Off
	Display Range	Off/On
	Network Access	Read/Write

**RELATIVE HUMIDITY** — Space Relative Humidity reading from the optional relative humidity sensor. The humidity reading is used for display and monitoring purposes only.

Relative Humidity:	Display Units	% RH
	Default Value	0
	Display Range	0 to 100
	Network Access	Read/Write

→ Table 4 — Status Screen

DESCRIPTION	VALUE	UNITS	STATUS	FORCE	NAME
Terminal Mode	HEAT				MODE
Terminal Type	SER FAN				TYPE
Controlling Setpoint	69.0	dF			CNTSP
Space Temperature	66.0	dF			SPACE_T
Damper Position	0	%OPEN			DMFPOS
Supply Air Temperature	67.1	dF			SAT
Local Heating Capacity	100	%			HCAP
Terminal Fan	On				FAN
Relative Humidity	0.0	%			RH
Demand Ventilation (ppm)	0				DCV
Primary Air Temperature	66.0	dF			PATEMP
Heat	Enable				HEAT
Remote Start	Off				REMTICIN

DEMAND VENTILATION — This variable displays the amount of CO<sub>2</sub> in the air as read from the demand ventilation sensor if DCV (demand control ventilation) is specified.

NOTE: The zone controller either reads relative humidity or demand ventilation depending on what is specified in the Control Options configuration. If this point is not specified, it is available for use as a software point.

Demand Ventilation:    Display Units    ppm  
                                   Default Value    0  
                                   Display Range    0 to 5000  
                                   Network Access    Read/Write

→ PRIMARY AIR TEMPERATURE — Primary air temperature from sensor (10 kΩ, Type II), located in main trunk of ductwork for supply air provided by the air source equipment. Used for linkage coordination of linked systems, not local operation.

Primary Air Temperature:    Display Units    F (C)  
   Default Value    0.0  
   Display Range    -40.0 to 245.0  
   Network Access    Read/Write

HEAT (ENABLE/DISABLE) — Provides enable/disable function for local heat at the terminal. When enabled the Local heat capacity function will run to operate the terminal heat.

Heat Display:    Display Units    Discrete ASCII  
                                   Default Value    Disable  
                                   Display Range    Disable/Enable  
                                   Network Access    Read/Write

REMOTE START — This variable displays the value of the remote timeclock input point that can be used for occupancy override. The input point is configured as normally open or normally closed in the Terminal Service Configuration Table. The occupancy mode of the zone controller will depend on the configuration of the timeclock input and the value of the input as follows:

REMOTE TIMECLOCK INPUT	CONFIGURATION	OCCUPANCY
Off (default)	Normally Closed (default)	Occupied (default)
On	Normally Closed	Unoccupied
Off	Normally Open	Unoccupied
On	Normally Open	Occupied

The user can override the zone controller's unoccupied mode by forcing Remote Start to *On*. The default state (Normally Closed and Off) is such that it may be used by controllers that do not have remote timeclock wiring.

Remote Start:    Display Units    Discrete ASCII  
                                   Default Value    Off  
                                   Display Range    On/Off  
                                   Network Access    Read/Write

### CONFIGURATION TABLES

The following sections describe the computer configuration screens which are used to configure the zone controller. The screens shown may be displayed differently when using different Carrier software. See Table 5.

**Alarm Configuration Table** — The Alarm Configuration Table (ALARMLIM) contains decisions used to configure the alarm settings for the zone controller. This includes re-alarm time, routing of alarms, limits for space temperature and demand control ventilation.

RE-ALARM TIME — This decision is used to configure the number of minutes the zone controller will wait before an alarm condition which has not been corrected will be re-transmitted on the communications network. Re-alarms of an alarm condition will continue until the condition no longer exists.

Alarm Re-Alarm Time:    Units    Minutes  
                                   Range    0 to 1440  
                                   Default Value    0 (Disabled)

ALARM ROUTING CONTROL — This decision indicates which Carrier Proprietary Network system software or devices will receive and process alarms sent by the zone controller. This decision consists of eight digits each can be set to zero or one. A setting of 1 indicates alarms should be sent to this device. A setting of zero disables alarm processing for that device. Currently the corresponding digits are configured for the following devices: first digit — user interface software; second digit — autodial gateway or Telink; fourth digit — alarm printer interface module; digits 3, and 5 through 8 — unused.

Alarm Routing Control:    Range    00000000 to 11111111  
   Default Value    00000000

SPACE TEMPERATURE OCCUPIED HYSTERESIS — This configuration defines the range above the occupied high set point and below the occupied low set point that the space temperature must exceed for an alarm condition to exist during occupied hours.

Space Temperature Occupied Hysteresis:    Units    delta F (delta C)  
   Range    0.0 to 99.9  
   Default Value    5.0

**Table 5 — Alarm Configuration Table**

DESCRIPTION	VALUE	UNITS	NAME
<b>Alarm Configuration</b>			
Re-alarm Time	0	min	RETIME
Alarm Routing	00000000		ROUTING
SPT Occupied Hysteresis	5.0	^F	SPTHYS
<b>Unoccupied SPT</b>			
Low Limit	40.0	dF	LOWLIM
High Limit	99.0	dF	HIGHLIM
<b>Demand Ctrl Ventilation</b>			
Low Limit	250.0		LOWLIM
High Limit	1200.0		HIGHLIM

**UNOCCUPIED SPACE TEMPERATURE LOW LIMIT**  
 — This configuration defines the lowest temperature that the unoccupied space can be before an alarm is generated.

Unoccupied Space Temperature

Low Limit:      Units      F (C)  
                     Range      0 to 255 F  
                     Default Value      40

**UNOCCUPIED SPACE TEMPERATURE HIGH LIMIT**  
 — This configuration defines the highest temperature that the unoccupied space can be before an alarm is generated.

Unoccupied Space Temperature

High Limit:      Units      F (C)  
                     Range      0 to 255 F  
                     Default Value      99

**DEMAND CONTROL VENTILATION LOW LIMIT** — This configuration defines the lowest CO<sub>2</sub> level reading that the occupied space can have before an alarm is generated.

Demand Control Ventilation

Low Limit:      Units      ppm  
                     Range      0 to 5000  
                     Default Value      250

**DEMAND CONTROL VENTILATION HIGH LIMIT** — This configuration defines the highest CO<sub>2</sub> level reading that the occupied space can have before an alarm is generated.

Demand Control Ventilation

High Limit:      Units      ppm  
                     Range      0 to 5000  
                     Default Value      1200

**Terminal Service Configuration Table** — The Terminal Service Configuration Table (CONFIG) contains decisions used to configure the main settings for the zone controller. This includes Terminal Type, Primary Inlet Size, and gains for the damper and heating PID loops. Decisions regarding auxiliary heat are made in this table and up to 10 temperature readings can be configured for room temperature sensor averaging. SPT and SAT sensor trimming are done here as well. See Table 6.

**TERMINAL TYPE** — This configuration is used to indicate the terminal type that the zone controller is installed on. A 1 is for Single Duct terminals, a 2 is for Parallel Fan terminals, and a 3 is for Series Fan terminals.

Terminal Type:      Range      1 to 3  
                     Default Value      1

→ **PRIMARY INLET SIZE** — The Primary Inlet Size configuration is used to input the inlet diameter of the terminal if used with a round inlet. The Inlet Area configuration is used for oval or rectangular inlets. The zone controller will use the larger value for demand weighting if both values are configured. If both inlet size and inlet area are zero, then the damper will not be included in the average demand calculations.

NOTE: Carrier sizes 12, 14, and 16 are oval.

Primary Inlet Size

(Inlet Diameter):      Units      Inches  
                                     Range      0.0 to 24.0  
                                     Default Value      6.0

→ **INLET AREA** — The Inlet Area configuration is used if the terminal has an oval or rectangular inlet. The Primary Inlet Size configuration is used for round inlets. The zone controller will use the larger value for demand weighting if both values are configured. If both inlet size and inlet area are zero, then the damper will not be included in the average demand calculations.

Inlet Area:      Units      Square Inches  
                             Range      0.0 to 500.0  
                             Default Value      0.0

**DAMPER LOOP PARAMETERS** — The loop gains and start value define how the terminal will respond to deviations in measured temperature in order control to the damper position.

The Proportional Gain is calculated each time the airflow is compared to the active airflow set point. As the error from set point goes to zero, the proportional term will also go to zero.

The Integral Gain is a running summation of all integral terms since the loop started. This has the effect of trimming off any offset from the set point which might occur, if only the proportional term existed. Normally a proportional loop with no integral term would require frequent adjustments of the starting value to eliminate the offset as static pressure and other conditions change.

The derivative gain tends to nullify or accelerate the changes in the proportional gain depending on the size of the error from the set point. This allows the damper to respond faster and more efficiently to accurately maintain the space temperature set points. The Start Value is the initial value that is then modified by the error terms of the PID calculation.

Damper Loop Parameters

Proportional Gain:      Range      00.0 to 99.9  
                                     Default Value      10.0  
 Integral Gain:      Range      00.0 to 99.0  
                                     Default Value      2.5  
 Derivative Gain:      Range      00.0  
                                     Default Value      4.0  
 Start Value:      Units      %  
                             Range      0 to 100  
                             Default Value      40

**CLOCKWISE ROTATION** — This configuration is used to define what effect a clockwise rotation of the actuator will have on the damper. If the actuator rotates clockwise to closed position, the configuration should be set to Close. If the actuator rotates clockwise to open, the configuration should be set to open. This configuration is used to change the rotation of the actuator so that the damper transducer calibration will work properly. The actuator does not have to be re-installed nor any switches changed to reverse the action.

Clockwise

Rotation:      Range      Close/Open  
                     Default Value      Close

→ Table 6 — Terminal Service Configuration Table

DESCRIPTION	VALUE	UNITS	NAME
<b>COOLING</b>			
Terminal Type	1		TERMTYPE
1 = Single Duct			
2 = Parallel Fan			
3 = Series Fan			
Primary Inlet Size			
Inlet Diameter (Inches)	6.0		RNDSZ
Inlet Area (Sq. In.)	0.0		SQA
Damper PID			
Proportional Gain	10.0		KP
Integral Gain	2.5		KI
Derivative Gain	4.0		KD
Starting Value	40.0	%	STARTVAL
CW Rotation	Close		DMPDIR
<b>HEATING</b>			
Heat Type	0		HEATTYPE
0 = None			
2 = Two Position			
3 = Staged Electric			
4 = Modulating/CV			
5 = Combination			
Heating PID			
Proportional	10.0		KP
Integral Gain	0.5		KI
Derivative Gain	0.0		KD
Starting Value	80.0	dF	STARTVAL
Ducted Heat	Yes		DUCTHEAT
Maximum Temperature	110	dF	MAXTEMP
# Electric Heat Stages	3		STAGES
Heat On Delay	2	min	HONDEL
Fan Off Delay	2	min	FNOFFD
2-Pos Heat Logic	Normal		HEATTYPE
System Call for Heat?	Yes		HEATCALL
Supp. Heat Lockout Temp.	140.0	dF	SHL_TEMP
System Pilot Averaging	0		SENS_AVG
0 = System Pilot only			
1 = with one T55			
2 = with four T55s			
3 = with nine T55s			
SPT Sensor Trim	0.0	^F	SPTRIM
SAT Sensor Trim	0.0	^F	SATTRIM
Local SAT Installed	Yes		LOC_SAT
Remote Contact Config	Close		RMTCFG

**HEAT TYPE** — This configuration is used to define the type of heat installed on the terminal. A 0 or 1 is equal to None. A 2 is equal to Two Position. A 3 is equal to Staged Electric. A 4 is equal to Modulating/CV. A 5 is equal to combination.

Heat Type:	Range	0 to 5
	Default Value	0

**HEATING LOOP PARAMETERS** — The heating loop gains and start value define how the terminal will respond to deviations in measured space temperature in order to control to the heat set point.

The Proportional Gain is calculated each time the space temperature is compared to the heat set point. As the error from set point goes to zero, the Proportional Gain will also go to zero.

The Integral Gain is a running summation of all integral terms since the loop started. This has the affect of trimming off any offset from set point which might occur if only the Proportional Gain existed. Normally a proportional loop with no Integral Gain would require frequent adjustments of the starting value to eliminate the offset as loading conditions on the room change.

The Derivative Gain is not needed. This term tends to nullify large changes in the Proportional Gain for dampened response.

The Start Value is the initial value that is then modified by the Error terms of the PID calculation.

**Heating Loop Parameters**

Proportional Gain:	Range	00.0 to 99.9
	Default Value	8.0

Integral Gain:	Range	00.0 to 99.0
	Default Value	3.0

Derivative Gain:	Range	00.0
	Default Value	0.0

Start Value:	Units	F (C)
	Range	40 to 125
	Default Value	80

**DUCTED HEAT** — The Ducted Heat configuration is used to configure the terminal for ducted heat. If a local heat source is in the duct and requires airflow to provide heat, set the Ducted Heat configuration for yes.

Ducted Heat:	Range	No/Yes
	Default Value	Yes

**MAXIMUM TEMPERATURE** — This configuration is used to configure the maximum supply-air temperature desirable for heating the space. This will cause the heat to be modulated or cycled using this value as the maximum temperature of the air to be supplied.

Maximum Temperature:	Units	F (C)
	Range	40 to 200
	Default Value	110

**NUMBER OF ELECTRIC STAGES** — This configuration is used to define the number of stages of electric heat controlled by the zone controller.

Number of Electric Stages:	Range	1 to 3
	Default Value	1

**HEAT ON DELAY** — The Heat On Delay configuration is used to define a delay from the time a parallel terminal fan is started until the heat is activated.

Heat On Delay:	Units	minutes
	Range	1 to 60
	Default Value	2

**FAN OFF DELAY** — The Fan Off Delay configuration is used to define a delay time. The delay time is from when the

heat is deactivated (in a parallel terminal) until the parallel fan is deactivated. This allows the fan to circulate air and remove the residual heat from the heat source.

Fan Off Delay:	Units	minutes
	Range	1 to 15
	Default Value	2

**TWO-POSITION HEAT LOGIC** — This configuration is used for controlling a normally closed or normally open valve for hot water. Use normal logic if the valve is normally closed. Use inverted logic if the valve is normally open.

Two Position Heat Logic:	Range	Normal/Invert
	Default Value	Normal

**SYSTEM CALL FOR HEAT?** — This decision is used whenever auxiliary heat is available and can handle the heat load for the zone without calling the system for heat. This prevents the entire building from going to heat for one cold room. Configure this decision to *No* when this zone should not be allowed to call the air source for heat.

System Call For Heat:	Range	No/Yes
	Default Value	Yes

**SUPPLEMENTAL HEAT LOCKOUT TEMP** — This configuration is the temperature setting that is compared to the outside air temperature to make a determination if supplemental heat at the zone will be allowed to operate.

Supplemental Heat Lockout Temp:	Units	F
	Range	-40.0 to 140 F
	Default	140

**SYSTEM PILOT AVERAGING** — This configuration determines how multiple sensors are averaged with the System Pilot. A 0 equals System Pilot only. A 1 equals with one T55 sensor. A 2 equals with four T55 sensors. A 3 equals with nine T55 sensors.

System Pilot Averaging:	Range	0-3
	Default Value	0

**SPACE TEMPERATURE TRIM** — This configuration is used to trim a space sensor which might need calibration. For example, if the temperature displayed is two degrees above the value measured with calibrated test equipment, input a value of -2.0.

System Pilot Trim:	Units	delta F (delta C)
	Range	-9.9 to 9.9
	Default Value	0.0

**SUPPLY AIR TEMPERATURE TRIM** — This configuration is used to trim a supply air sensor which might need calibration. For example, if the temperature displayed is two degrees above the value measured with calibrated test equipment, input a value of -2.0.

Supply Air Temperature Trim:	Units	delta F (delta C)
	Range	-9.9 to 9.9
	Default Value	0.0

**LOCAL SAT INSTALLED** — This configuration tells the zone controller if a local SAT sensor is installed. When configured as "Yes", the zone controller will use this information to determine if the local SAT sensor has failed or is out of range and has sensed an alarm. When configured to "No", the SAT point will read 0.0° F and the SAT alarm condition will be cleared.

Local SAT Installed:	Range	No/Yes
	Default	Yes



**REMOTE CONTACT CONFIG** — The remote timeclock contact input can be configured as a normally open or normally closed contact. When the timeclock input is 'On' the zone will follow it's local occupancy schedule. When the timeclock input is 'Off' the zone will be forced into unoccupied state.

Remote Contact Config:	Range	Close/Open
	Default Value	Close

**Damper Service Configuration Table** — The Damper Service Configuration Table (DAMPER) contains decisions used to configure the damper minimum, maximum and ventilation positions. See Table 7.

**COOL MINIMUM POSITION** — This configuration is the minimum damper position the terminal will control to when the equipment mode is Cooling (or Fan Only), or free cooling and the space requirements for cooling are at a minimum.

Cool Minimum Position:	Units	%
	Range	0 to 100
	Default Value	0

**COOL MAXIMUM POSITION** — This configuration is the maximum damper position the terminal will control to when the equipment mode is cooling (or fan only), or free cooling and the space requirements for cooling are at a maximum.

Cool Maximum Position:	Units	%
	Range	0 to 100
	Default Value	100

**REHEAT MINIMUM POSITION** — This configuration is for single duct units with ducted reheat. Configure the desired damper position at which the reheat will provide optimum performance. This value is compared to the Minimum Cool value and the greater of the two values is used to determine the damper position.

Reheat Minimum Position:	Units	%
	Range	0 to 100
	Default Value	0

**HEAT MINIMUM POSITION** — This configuration is the Minimum damper position the terminal will control to when the equipment mode is Warm-Up or Heat. If the terminal is not configured for VAV central heating this is the only position the terminal will control to for these equipment modes.

Heat Minimum Position:	Units	%
	Range	0 to 100
	Default Value	0

**HEAT MAXIMUM POSITION** — This configuration is used to configure the maximum damper position at which the zone controller will operate if VAV central heat is configured to yes. If the equipment mode is Heat or Warm-Up and the demand in the space is for heat the zone controller will calculate the proper damper position needed to achieve space temperature set point, operating between the Heat Min and Heat Max.

Heat Maximum Position:	Units	%
	Range	0 to 100
	Default Value	100

**VENTILATION POSITION** — This configuration is used to specify the ventilation damper position the terminal will control to when the air source operating mode is *VENT*.

Ventilation Position:	Units	%
	Range	0 to 100
	Default Value	30

**Holiday Configuration Table** — The Holiday Configuration Table (HOLDY.xxS) contains decisions used to configure the start date and duration of holidays. See Table 8.

**START MONTH** — The start month is the month in which the holiday starts. Months are represented by numbers with 1 representing January, 2 February, up to 12.

Start Month:	Range	1 to 12
	Default Value	1

**START DAY** — The start day is the day on which the holiday will start.

Start Day:	Range	1 to 31
	Default Value	1

**DURATION** — Length of time, in days, that the holiday will last.

Duration:	Range	0 to 365
	Default Value	0

**Linkage Configuration Table** — The Linkage Configuration Table (LINKAGE) contains decisions used to configure the linkage coordinator zone controller's linkage settings. This is where the linkage coordinator zone controller, the air source and the bypass controller options are configured. It also includes Carrier Network Function Configuration used for collecting data from multiple controllers and finding the high, low or average value and transferring the data to another controller. This table is also used to setup Temperature Sensor Grouping, which is the sharing of one space temperature sensor among multiple zone controllers. See Table 9.

**LINKAGE MASTER ZONE** — This decision defines if the zone controller will function as a Linkage Coordinator (Linkage Master) for itself and other zones.

If the zone controller is to use a supply air sensor for stand-alone operation, this configuration must be configured to No and the number of Zones to 1.

If the zone controller will use its primary air sensor to determine the air handler mode for a number of zone controllers, configure this configuration to Yes, input the number of zones, and leave the air source decisions at the default values of zero.

If this zone controller will communicate linkage information with an air source, configure this configuration to Yes. The number of zones must be configured and the address of the air source entered.

Linkage Master Zone:	Range	Yes/No
	Default Value	No

**NUMBER OF ZONES** — This decision defines the number of zone controllers (including itself) for the Linkage Coordinator to scan and include as part of the average temperature, set points, and occupancy information to the air source. The address of the zone controller functioning as a Linkage Coordinator must be larger than the number of zones configured. The zone controller will scan addresses less than its own, including information for as many zones as are configured. Other zone controller configured as linkage coordinators will also be included, so it is possible to have zones scanned by more than one linkage coordinator. Therefore care must be taken in addressing to prevent overlapping systems, unless overlapping systems is necessary. In large buildings the use of bridges and multiple busses is recommended to improve communication and provide system differentiation.

Number of Zones:	Range	1 to 32
	Default Value	1

AIR SOURCE BUS AND ELEMENT NUMBER — The Air Source Bus and Element Number configurations define the address of the air source providing conditioned air to the zones controlled by the linkage coordinator. If the address is left at zero, the linkage coordinator will look for a primary air sensor to determine the equipment mode. If no primary air sensor is installed, or the sensor fails, the Linkage Coordinator will default the air source mode to Cooling.

Air Source  
 Bus Number: Range 0 to 239  
 Default Value 0

Air Source  
 Element Number: Range 0 to 239  
 Default Value 0

**Table 7 — Damper Service Configuration Table**

DESCRIPTION	VALUE	UNITS	NAME
Cool Minimum Pos	0	%	CMINPOS
Cool Maximum Pos	100	%	CMAXPOS
Reheat Minimum Pos	0	%	REMINPOS
Heat Minimum Pos	0	%	HMINPOS
Heat Maximum Pos	100	%	HMAXPOS
Ventilation Pos	30	%	VENTPOS

**Table 8 — Holiday Configuration Table**

DESCRIPTION	VALUE	UNITS	NAME
Start Month	1		MONTH
Start Day	1		DAY
Duration	0		DURATION

→ **Table 9 — Linkage Configuration Table**

DESCRIPTION	VALUE	UNITS	NAME
<b>Zone Linkage</b>			
Linkage Master Zone	No		MZENA
Number of Zones	1		NSYSTZ
Air Source Bus #	0		ASBUSN
Air Source Element #	0		ASELEMN
System Bypass Exists	Yes		SYS_BP
AST Mode Verification	No		AST_CHCK
AST Sensor Location	0		AST_LOC
0 = Airsource			
1 = Local PAT			
2 = Bypass			
<b>CCN-LINKAGE DATA</b>			
CCN Variable Name			CCNVAR
CCN Func Config	0		CCNFUNC
0 = None			
1 = Average			
2 = Low			
3 = High			
Data Transfer Rate	10	min	DATARATE
CCN Output Point			CCNOUTP
Destination Bus #	0		DESTBUSN
Destination Element #	0		DESTELN
<b>TEMP SENSOR GROUPING</b>			
Sensor Mode	1		BRD_RECV
1 = Local Sensor			
2 = Broadcast			
3 = Listen			
Listen Sensor Config	1		SENSCFG
1 = SPT			
2 = SPT & Offset			
Broadcasting Element #	1		BRDDEVID

**SYSTEM BYPASS EXISTS** — This decision is used to tell the linkage coordinator that an optional bypass controller does or does not exist in this system. If this decision is set to *Yes*, the linkage coordinator will attempt to communicate with a bypass controller whose address must be one higher than the linkage coordinator. If this decision is set to *No*, the linkage coordinator will not attempt to communicate with a bypass controller.

System		
Bypass Exists:	Range	Yes/No
	Default Value	Yes

→ **AST MODE VERIFICATION** — This decision is used to tell the linkage coordinator whether or not to qualify the mode sent to it by comparing the air source supply air temperature value to space temperature to ensure the air source is discharging an appropriate supply air temperature for the current heat/cool mode. If heating is required but the supply air temperature is too cool for heating, the zone controller will act as if the air source mode is cool rather than heat.

AST Mode		
Verification:	Range	Yes/No
	Default Value	No

→ **AST SENSOR LOCATION** — This decision is used to specify where the air source supply air temperature sensor is located. It may be located at the air source, at the bypass controller, or there may be an optional primary air temperature sensor (PAT) installed in the primary air duct.

AST Sensor		
Location:	Units	none
	Range	0 = air source, 1 = local PAT, 2 = bypass
	Default Value	0

**CCN LINKAGE DATA** — A zone controller configured as a linkage coordinator has the ability to poll its linked zones and collect the high, low or average value of any variable within its linked zones. Once the high, low or average is determined, the linkage coordinator can then transfer that value to a configured bus number, element number and point name. Typically this feature is used to determine a system's highest indoor air quality reading.

In order to utilize this feature the CCN Variable Name being collected from the linked zones must be supplied. The data transfer rate must be specified and whether the high, low, or average value is being determined. After the value has been determined, a valid point name and communication bus address to transfer the value to must be entered.

CCN Variable		
Name:	Units	ASCII (8 Characters)
	Range	A-Z, 0-9
	Default Value	(blank)

CCN Function		
Config:	Units	none
	Range	0 = none, 1 = average, 2 = low, 3 = high
	Default Value	3

Data Transfer		
Rate:	Units	minutes
	Range	1-15
	Default Value	10

CCN Output		
Point:	Units	ASCII (8 Characters)
	Range	A-Z, 0-9
	Default Value	(blank)

Destination Bus		
Number:	Units	none
	Range	0-239
	Default Value	0

Destination		
Element Number:	Units	none
	Range	0-239 (0 = disabled)
	Default Value	0

**TEMP SENSOR GROUPING** — Each zone controller has the capability to broadcast the associated space temperature sensor's data or listen to another controller's sensor data over the network. All controllers sharing the same sensor must be installed on the same communication bus.

There are three configuration decisions that must be configured in order to share sensors. The Temp Sensor Mode is used to specify if a controller will use its own local sensor, broadcast its local sensor, or listen to another controller's sensor broadcast. The Listen Sensor Config is used to specify if the controller is sharing the space temperature information only or the space temperature and temperature offset sidebar information. The Broadcast Element Number decision is used to specify which controller number a zone will listen for when configured to receive another controller's broadcast.

Temp Sensor		
Mode:	Units	none
	Range	1 = Local Sensor, 2 = Broadcast, 3 = Listen
	Default Value	1

Listen Sensor		
Config:	Units	none
	Range	1 = SPT, 2 = SPT and offset
	Default Value	1

Broadcast		
Element Number:	Units	None
	Range	1-239
	Default Value	1

**Language Configuration Table** — The Language Configuration table (LNGCONF) is used to select the display language that will be seen on all user interfaces for this controller. By default, the zone controller displays information in English. To change to a second language display, set this decision to *No*, download this table and then upload the zone controller to see the factory-loaded second language. If a second language is not available in this module, this decision will be disregarded and information will continue to be displayed in English.

English		
Language:	Range	No/Yes
	Default Value	Yes

**Master (Linkage Coordinator) Service Configuration Table** — The Master (Linkage Coordinator) Service Configuration Table (MASTER) contains decisions used by the linkage coordinator zone controller to determine the system demand mode (heat/cool/vent). See Table 10.

**COOL START AVERAGE DEMAND** — This decision is used to configure the minimum average cooling demand that must be met before the system will start in cooling mode if no mode is currently active.

**NOTE:** If there is also an average heating demand, and it is also greater than its configured minimum average heating demand (Heat Start Avg. Demand), then the mode with the greater demand will be selected. If both heating and cooling average demand are exactly the same then the mode with the greatest individual zone demand will determine the starting system mode.

Cool Start		
Average Demand:	Units	delta F (C)
	Range	0.5 to 5.0
	Default Value	0.7

**Table 10 — Master Service Configuration Table**

DESCRIPTION	VALUE	UNITS	NAME
Cool Start Avg. Demand	0.7	^F	CSA_DMD
Cool Mode Hysteresis	0.7	^F	C_HYST
Heat Start Avg. Demand	0.7	^F	HSA_DMD
Heat Mode Hysteresis	0.7	^F	H_HYST
System Mode Reselect	30	min	RESELECT
Cool Time Guard Timer	0	min	C_MOD_TG
Heat Time Guard Timer	0	min	H_MOD_TG
Cont. Fan When Occ?	Yes		FAN_MODE
Heat Mode Lockout Setp	140.0	dF	HLO_SPT
Cool Mode Lockout Setp	-40.0	dF	CLO_SPT

**COOL MODE HYSTERESIS** — This decision is used to configure the hysteresis that will be used to determine when the cooling mode will end. The cooling mode ends when the average cooling demand drops below the minimum average demand minus the hysteresis: (average cooling demand < Cool Start Avg. Demand — Cool Mode Hysteresis)

Cool Mode

Hysteresis:      Units            delta F (C)  
                          Range            0.5 to 5.0  
                          Default Value    0.7

**HEAT START AVERAGE DEMAND** — This decision is used to configure the minimum average heating demand that must be met before the system will start in heating mode if no mode is currently active.

**NOTE:** If there is also an average cooling demand, and it is also greater than its configured minimum average cooling demand (Cool Start Avg. Demand), then the mode with the greater demand will be selected. If both heating and cooling average demand are exactly the same then the mode with the greatest individual zone demand will determine the starting system mode.

Heat Start

Average Demand: Units            delta F (C)  
                          Range            0.5 to 5.0  
                          Default Value    0.7

**HEAT MODE HYSTERESIS** — This decision is used to configure the hysteresis that will be used to determine when the heating mode will end. The heating mode ends when the average heating demand gets below the minimum average demand minus the hysteresis: (average heating demand < Heat Start Avg. Demand - Heat Mode Hysteresis)

Heat Mode

Hysteresis:      Units            delta F (C)  
                          Range            0.5 to 5.0  
                          Default Value    0.7

**SYSTEM MODE RESELECT** — This decision is used to configure the minimum time that must elapse before a mode change can take effect.

System Mode

Reselect:        Units            minutes  
                          Range            0 to 255  
                          Default Value    30

**COOL TIME GUARD TIMER** — This decision is used to configure the minimum time that the cooling mode must be active before a mode change can take effect. The Cool Time Guard Timer becomes active whenever the cooling mode goes into effect.

Cool Time

Guard Timer:    Units            minutes  
                          Range            0 to 255  
                          Default Value    0

**HEAT TIME GUARD TIMER** — This decision is used to configure the minimum time that the heating mode must be active before a mode change can take effect. The Heat Time Guard Timer becomes active whenever the heating mode goes into effect.

Heat Time

Guard Timer:    Units            minutes  
                          Range            0 to 255  
                          Default Value    0

**CONT. FAN WHEN OCC** — This decision is used to configure the air source fan to go *On* whenever the zone is in an occupied mode. If this decision is set to *No*, the fan will cycle on and off during occupied modes in order to maintain set point.

Cont. Fan

When Occ:        Range            No/Yes  
                          Default Value    Yes

**HEAT MODE LOCKOUT SET POINT** — This decision is used to lock out the heating mode by comparing this value to outdoor air temperature. If the outdoor air temperature reading is valid and greater than this value then the heating mode will be locked out. If outdoor air temperature drops 3 degrees below the Heat Mode Lockout Set Point, the lockout is cancelled. This 3-degree hysteresis is fixed.

Heat Mode Lockout

Set Point:        Units            F (C)  
                          Range            -40.0 to 140.0  
                                             (140 = disable)  
                          Default Value    140

**COOL MODE LOCKOUT SET POINT** — This decision is used to lock out the cooling mode by comparing this value to outdoor air temperature. If the outdoor air temperature reading is valid and less than this value then the cooling mode will be locked out. If outdoor air temperature raises 3 degrees above the Cool Mode Lockout Set Point, the lockout is cancelled. This 3-degree hysteresis is fixed.

Cool Mode Lockout

Set Point:        Units            F (C)  
                          Range            -40.0 to 140.0  
                                             (-40 = disable)  
                          Default Value    -40

**Time Schedule Configuration Table** — The Time Schedule Configuration Table (OCCDEFCS) contains decisions used to configure the zone controller's occupancy schedule. For flexibility of scheduling, the occupancy configuration is broken into eight separate periods. See Table 11.

**MANUAL OVERRIDE HOURS** — The Manual Override Hours decision is used to command a timed override by entering the number of hours the override will be in effect.

If the occupancy schedule is occupied when this number is downloaded, the current occupancy period will be extended by the number of hours downloaded.

If the current occupancy period is unoccupied when the occupancy override is initiated, the mode will change to occupied for the duration of the number of hours downloaded.

If the occupancy override will end after the start of the next occupancy period, the mode will transition from occupancy override to occupied without becoming unoccupied, and the occupancy override timer will be reset.

An active occupancy override or a pending occupancy override may be canceled by downloading a zero to this configuration. Once a number other than zero has been downloaded to this configuration any subsequent downloads of any value other than zero will be ignored by the zone controller.

**Manual Override**

Hours:	Units	hours
	Range	0 to 4
	Default Value	0

**OCCUPANCY SCHEDULING** — For flexibility of scheduling, the occupancy programming is broken into eight separate periods. For each period the scheduling, the active days of the week, occupied start time, and occupied stop time needs to be configured.

**DAY OF WEEK** — This configuration consists of eight fields corresponding to the seven days of the week and a holiday field in the following order: Monday, Tuesday, Wednesday, Thursday, Friday, Saturday, Sunday, Holiday. A separate configuration screen is used.

If a 1 is configured in the corresponding place for a certain day of the week, the related “Occupied from” and “Occupied to” times for that period will take effect on that day of the week. If a 1 is placed in the holiday field the related times will take effect on a day configured as a holiday. A zero means the schedule period will not apply to that day.

Period (1-8):

Day of Week:	Range	0 or 1
	Default Values	1111111 for period 1, 0000000 for periods 2-8.

**OCCUPIED FROM** — This field is used to configure the hour and minute, in military time, when the mode for the zone controller becomes occupied.

Period (1-8):

Occupied from:	Units	Hours: Minutes
	Range	00:00 to 24:00
	Default Value	00:00

**OCCUPIED TO** — This field is used to configure the hour and minute, in military time, when the occupied mode for the zone controller becomes unoccupied.

Period (1-8):

Occupied from:	Units	Hours: Minutes
	Range	00:00 to 24:00
	Default Value	24:00

**Option Service Configuration Table** — The Option Service Configuration Table (OPTIONS) contains decisions used to configure the service options of the zone controller. This includes such things as whether the zone controller is a global schedule master, a global set point master, a broadcast acknowledger, and whether it will be using demand control ventilation. This is also where loadshed parameters are configured. See Table 12.

**OCCUPANCY SCHEDULE NUMBER** — The Occupancy Schedule Number defines what Occupancy schedule the zone controller will use. Occupancy Schedule 64 is a local schedule. Occupancy Schedules 65 to 99 are global schedules.

Occupancy Schedule

Number:	Range	64 to 99
	Default Value	64

**GLOBAL SCHEDULE MASTER** — The Global Schedule Master configuration allows the Occupancy Schedule to be used as a Global Schedule Master (Occupancy Schedules 65-99).

**Global Schedule**

Master:	Range	No/Yes
	Default Value	No

→ **OVERRIDE** — The Override parameter is used to configure the number of hours and minutes the override will be in effect. The user initiates override by pressing the override button on the space temperature sensor. This will cause the schedule to enter into the Occupied mode. If global scheduling is used, all zones using the global schedule will enter Occupied mode. Pushing the override button during Occupied mode will have no effect.

If the occupancy override is due to end after the start of the next occupancy period, the mode will transition from occupancy override to occupied without becoming unoccupied, and the occupancy override timer will be reset.

**NOTE:** If using the tenant billing function, the override hours set point must be configured between 1 and 3 hours.

Override:

	Units	Hours: Minutes
	Range	00:00 to 24:00
	Default Value	00:00

**SET POINT GROUP NUMBER** — The Set Point Group Number is used to define the current zone controller as a part of a group of zone controllers which share the same set points. All zone controllers with the same Set Point Group Number will have the same set points. The set points are broadcast to the group by the zone controller defined by the Global Set Point Master configuration. A value of 0 is a local schedule. Values 1 to 16 are used for global scheduling.

Set Point

Group Number:	Range	0 to 16
	Default Value	0

**GLOBAL SET POINT MASTER** — This configuration defines if the current zone controller will broadcast its set point values to the other zone controllers which are made part of the same group by configuring the Set Point Group Number.

**Global Set Point**

Master:	Range	No/Yes
	Default Value	No

**MAXIMUM OFFSET ADJUSTMENT** — This configuration determines the maximum amount that the set point will be biased (up or down), by adjusting the slide bar on the space temperature sensor (if installed).

Maximum Offset

Adjustment:	Units	delta F (delta C)
	Range	0 to 15
	Default Value	2

**BROADCAST ACKNOWLEDGER** — This configuration defines if the zone controller will be used to acknowledge broadcast messages on the communication bus. One broadcast acknowledger is required per bus, including secondary busses created by the use of a bridge.

Broadcast

Acknowledger:	Range	No/Yes
	Default Value	No

**LOADSHED FUNCTION GROUP NUMBER** — This decision is used to assign the number that the loadshed function will use when transmitting alerts and commands to differentiate this loadshed group from any other loadshed group in the network. The loadshed algorithm is disabled if the value 0 is entered in this decision.

Loadshed Function

Group Number:	Range	0 to 16
	Default Value	0

**Table 11 — Time Schedule Configuration Table**

DESCRIPTION	VALUE	UNITS	NAME
Manual Override Hours	0	hours	OVRD
Period 1 DOW (MTWTFSSH)	11111111		DOW1
Occupied from	00:00		OCC1
Occupied to	24:00		UNOCC1
Period 2 DOW (MTWTFSSH)	00000000		DOW2
Occupied from	00:00		OCC2
Occupied to	24:00		UNOCC2
Period 3 DOW (MTWTFSSH)	00000000		DOW3
Occupied from	00:00		OCC3
Occupied to	24:00		UNOCC3
Period 4 DOW (MTWTFSSH)	00000000		DOW4
Occupied from	00:00		OCC4
Occupied to	24:00		UNOCC4
Period 5 DOW (MTWTFSSH)	00000000		DOW5
Occupied from	00:00		OCC5
Occupied to	24:00		UNOCC5
Period 6 DOW (MTWTFSSH)	00000000		DOW6
Occupied from	00:00		OCC6
Occupied to	24:00		UNOCC6
Period 7 DOW (MTWTFSSH)	00000000		DOW7
Occupied from	00:00		OCC7
Occupied to	24:00		UNOCC7
Period 8 DOW (MTWTFSSH)	00000000		DOW8
Occupied from	00:00		OCC8
Occupied to	24:00		UNOCC8

→ **Table 12 — Option Service Configuration Table**

DESCRIPTION	VALUE	UNITS	NAME
Occupancy Schedule #	64		SCH_NUM
Global Schedule Master	No		GS_MAST
Override (Hours: Minutes)	00:00		OVR
Setpoint Group #	0		SET_NUM
Global Setpoint Master	No		SET_MAS
Maximum Offset Adjust	2.0	^F	SET_LIMIT
Broadcast Acknowledger	No		BROACK
Loadshed Function			
Group Number	0		LDSEGRP
Loadshed Offset Adjust	2.0	^F	LOADLIMIT
Maximum Loadshed Time	60	min	MAXSHED
Control Options	0		CTLOPT
0 = None			
1 = RH (Monitor Only)			
2 = DCV			
Demand Ctrl Ventilation			
Proportional Gain	0.10		KP
Integral Gain	0.03		KI
Maximum Output Value	100.0	%	MAXOUT
DCV Low Voltage	0.0	Volts	DCVINLO
DCV High Voltage	10.0	Volts	DCVINHI
DCV Low Ref (ppm)	0		DCVLO
DCV High Ref (ppm)	2000		DCVHI

**LOADSHED OFFSET ADJUST** — This decision is used to configure an amount by which the Occupied Heating and Occupied Cooling set points will be relaxed in response to a redline broadcast. The zone controller responds to a loadshed event similar to a redline event, if the loadshed command is preceded by a redline event.

Specifically, if the unit is already in redline when the loadshed command is received, the zone controller will drop one stage of heat if heating, provided there is more than one stage available.

If the unit is in cooling, the zone controller uses the Loadshed Offset Adjust to raise the cooling set point, if raising the setpoint by this amount will cause the space to be satisfied.

Also, if the system experiences a loadshed event while not in redline, it will treat the event as a redline event and raise or lower the cooling and heating set points by the amount configured in this decision.

**Loadshed Offset Adjustment:**

Units	delta F (delta C)
Range	0 to 15
Default Value	2

**MAXIMUM LOADSHED TIME** — This decision is used to specify the maximum amount of time that a redline or loadshed event may affect this zone. A timer starts at the beginning of the event and automatically terminates the event after this configurable time limit.

**Override:**

Units	Minutes
Range	0 to 240
Default Value	60

**CONTROL OPTIONS** — The Control Options configuration determines whether the zone controller will use a humidity sensor or an indoor air quality sensor. A configuration of 0 means no sensors are used. A configuration of 1 means a Humidity Sensor is used. A configuration of 2 means an IAQ Sensor is used.

**Control Options:**

Range	0 to 2
Default Value	0

**DEMAND CONTROL VENTILATION** — These configuration values define the calculation parameters for determining the airflow needed for demand control ventilation (DCV). The Maximum Output Value is measured in percentage of nominal terminal cfm.

**Proportional Gain:**

Range	0.0 to 9.99
Default Value	0.10

**Integral Gain:**

Range	0.00 to 9.99
Default Value	0.03

**Maximum Output Value:**

Range	0.0 to 100.0% (max cool damper position)
Default Value	100.0

**DCV LOW VOLTAGE** — This decision is used to define the lowest voltage that should be read from the demand control ventilation sensor.

**DCV Low Voltage:**

Units	volts
Range	0 to 10
Default Value	0

**DCV HIGH VOLTAGE** — This decision is used to define the highest voltage that should be read from the demand control ventilation sensor.

**DCV High Voltage:**

Units	volts
Range	0 to 10
Default Value	10

**DCV LOW REF (PPM)** — This decision is used to define the value in parts per million that correlate to the low voltage reading from the demand control ventilation sensor.

**DCV Low Ref (ppm):**

Units	ppm
Range	0 to 5000
Default Value	0

**DCV HIGH REF (PPM)** — This decision is used to define the value in parts per million that correlate to the high voltage reading from the demand control ventilation sensor.

**DCV High Ref (ppm):**

Units	ppm
Range	0 to 5000
Default Value	2000

**Set Point Configuration Table** — The Set Point Configuration Table (SETPOINT) contains decisions used to configure the zone controller's occupied and unoccupied heat and cool set points. It is also used to configure the demand control ventilation set point in parts per million (ppm). See Table 13.

**OCCUPIED HEAT** — The Occupied Heat set point is used to configure the heating set point for the zone controller during Occupied mode.

**Occupied Heat:**

Units	F (C)
Range	40.0 to 90.0
Default Value	70.0

**OCCUPIED COOL** — The Occupied Cool set point is used to configure the cooling set point for the zone controller during Occupied mode.

**Occupied Cool:**

Units	F (C)
Range	45.0 to 99.9
Default Value	74.0

**UNOCCUPIED HEAT** — The Unoccupied Heat set point is used to configure the heating set point for the zone controller during Unoccupied mode.

**Unoccupied Heat:**

Units	F (C)
Range	40.0 to 90.0
Default Value	55.0

**UNOCCUPIED COOL** — The Unoccupied Cool set point is used to configure the cooling set point for the zone controller during Unoccupied mode.

**Unoccupied Cool:**

Units	F (C)
Range	45.0 to 99.9
Default Value	90.0

**DEMAND VENT (PPM)** — This decision is used to configure the ventilation set point for the zone controller if optional Demand Control Ventilation support is used.

**Demand Vent:**

Units	ppm
Range	0 to 5000
Default Value	850

**Table 13 — Set Point Configuration Table**

DESCRIPTION	VALUE	UNITS	NAME
<b>Setpoints</b>			
Occupied Heat	70.0	dF	OHSP
Occupied Cool	74.0	dF	OCSP
Unoccupied Heat	55.0	dF	UHSP
Unoccupied Cool	90.0	dF	UCSP
Demand Vent (ppm)	850		DCVSP

## MAINTENANCE TABLES

The following sections describe the computer maintenance screens which are used to perform maintenance on the zone controller. The screens shown may be displayed differently when using different Carrier software.

**System Pilot Maintenance Table** — The System Pilot Maintenance Table (SP\_MAINT) displays the mode of the zone controller, the controlling set point, the zone's current space temperature and occupancy status and whether this zone controller is a master. It also displays this zone's occupied and unoccupied heat and cool set points which the user may alter from this table. This table provides ease of operation using the System Pilot. See Table 14. This screen can be accessed through the maintenance option on the System Pilot or through Carrier network software.

**TERMINAL MODE** — This variable will display the current operating mode of the terminal, if linkage is available, or the mode determined by the linkage coordinator using the primary air sensor, if available. If the primary air sensor has failed or was not installed, the linkage coordinator will assume the default mode of cooling.

Operating Mode: Display Range OFF COOL, HEAT, COMMISS, ZONE\_BAL, PRESSURE, EVAC, VENT, REHEAT  
Network Access Read only

**CONTROLLING SETPOINT** — Controlling Setpoint will display either the heating master reference or the cooling master reference depending upon what mode the terminal is in. The display will default to the heating master reference and display the last controlling master reference when in neither heating nor cooling.

Controlling Setpoint: Display Units F (C)  
Display Range: -40 to 245  
Network Access: Read only

**LINKAGE MASTER** — This variable displays whether this zone controller functions as the linkage coordinator for itself and other zones.

Linkage Master: Display Range No/Yes  
Network Access Read Only

→ **SPACE TEMPERATURE** — Space temperature from 10 kΩ thermistor (Type II) located in the space. The point name of the displayed Space Temperature is "SPACE\_T" in this status display table. This point may be forced for diagnostic purposes. A non-displayed variable named SPT also exists within the zone controller as a writeable point for normal operations with a System Pilot or other devices that will write a space temperature to the zone controller. The zone controller verifies that the SPT point is being written to before using it to update the SPACE\_T point. Values that are received at the SPT point may be averaged with the hardware space temperature input.

Space Temperature: Display Units F (C)  
Display Range -40.0 to 245.0  
Network Access Read/Write

**OCCUPIED** — This variable displays whether the zone controller is operating in the occupied mode.

Occupied: Display Range No/Yes  
Network Access Read Only

**OCCUPIED HEAT SET POINT** — This variable displays the weighted average of the occupied heat set point, calculated by the linkage coordinator, from the information received from polling its associated zones. The set points are weighted by

maximum airflow capacities of the zone controllers scanned by the linkage coordinator.

Occupied  
Heat Set Point: Display Units F (C)  
Display Range 40.0 to 99.9  
Network Access Read/Write

**OCCUPIED COOL SET POINT** — This variable displays the weighted average of the occupied cool set point, calculated by the linkage coordinator, from the information received from polling its associated zones. The set points are weighted by the maximum airflow capacities of the zone controllers scanned by the linkage coordinator.

Occupied  
Cool Set Point: Display Units F (C)  
Display Range 45.0 to 99.9  
Network Access Read/Write

**UNOCCUPIED HEAT SET POINT** — This variable displays the weighted average of the unoccupied heat set point, calculated by the linkage coordinator, from the information received from polling its associated zones. The set points are weighted by the maximum airflow capacities of the zone controllers scanned by the linkage coordinator.

Unoccupied  
Heat Set Point: Display Units F (C)  
Display Range 40.0 to 99.9  
Network Access None

**UNOCCUPIED COOL SET POINT** — This variable displays the weighted average of the unoccupied cool set point, calculated by the linkage coordinator, from the information received from polling its associated zones. The set points are weighted by the maximum airflow capacities of the zone controllers scanned by the linkage coordinator.

Occupied  
Cool Set Point: Display Units F (C)  
Display Range 45.0 to 99.9  
Network Access None

**System Pilot Alternate Maintenance Table** — The System Pilot Alternate Maintenance Table (ALT\_DISP) displays the current heating/cooling/ventilation mode as well as the damper position. See Table 15.

**NOTE:** This screen can only be viewed using the System Pilot. To view this screen, press the right button on the System Pilot for 5 seconds while at the default zone controller display. This screen cannot be viewed using Carrier network software.

**DAMPER POSITION** — This variable displays the damper position of the zone controller in the system.

Damper Position: Display Units % (open)  
Display Range 0.0 to 100.0  
Network Access Read/Write

**COOLING IN EFFECT** — This variable shows if cooling mode is currently in effect in the system.

Cooling In Effect: Display Range No/Yes  
Network Access Read/Write

**HEATING IN EFFECT** — This variable shows if heating mode is currently in effect in the system.

Heating In Effect: Display Range No/Yes  
Network Access Read/Write

**DCV IN EFFECT** — This variable shows if DCV is currently in effect in the system.

DCV In Effect: Display Range No/Yes  
Network Access Read/Write



→ Table 14 — System Pilot Maintenance Table

DESCRIPTION	VALUE	UNITS	STATUS	FORCE	NAME
Terminal Mode	HEAT				MODE
Controlling Setpoint	69.0	dF			CNTSP
Linkage Master (coordinator)	Yes				LINKMAST
Space Temperature	66.0	dF			SPACE_T
Occupied	No				ZONEOCC
Occupied Heat Setpoint	70.0	dF			OHSP
Occupied Cool Setpoint	74.0	dF			OCSP
Unoccupied Heat Setpoint	55.0	dF			UHSP
Unoccupied Cool Setpoint	90.0	dF			UCSP

Table 15 — System Pilot Alternate Maintenance Table

DESCRIPTION	VALUE	UNITS	STATUS	FORCE	NAME
Damper Position	0	%OPEN			DMPPPOS
Cooling in Effect	No				COOLFLAG
Heating in Effect	Yes				HEATFLAG
DCV in Effect	No				DCVFLAG

**Linkage Maintenance Table** — The Linkage Maintenance Table (LINKMNT) displays linkage data for the Linkage Coordinator zone controller. This data includes air source operating mode, air source supply temperature, and all set points and current and occupied temperatures of the reference zone. It also displays composite occupancy data for the linked zones including next occupied day and time, next unoccupied day and time and previous unoccupied day and time. See Table 16.

**AIR SOURCE BUS NUMBER** — This variable will display the bus number of the air source that the zone controller will be communicating Linkage to, if this zone is the Linkage Coordinator.

Air Source  
 Bus Number:     Range           0 to 239  
                   Network Access   None

**AIR SOURCE ELEMENT NUMBER** — This variable will display the Element Address of the Air Source that the zone controller will be communicating Linkage to, if this zone is the Linkage Coordinator.

Air Source  
 Element Number: Display Range   1 to 239  
                   Network Access   None

**MASTER ZONE ELEMENT NUMBER** — This variable will display the element address of the zone which is the Linkage Coordinator.

Master Zone  
 Element Number: Display Range   1 to 239  
                   Network Access   Read only

**OPERATING MODE** — This variable will display the current operating mode of the air source, if Linkage is available, or the mode determined by the Linkage Coordinator using the primary air sensor, if available. If the primary air sensor has failed or was not installed, the Linkage Coordinator will assume the default mode of cooling.

Operating Mode: Display Range   COOLING, HEATING,  
   FREECOOL,   PRES-  
   SURE, EVAC, OFF  
                   Network Access   Read only

**AIR SOURCE SUPPLY TEMPERATURE** — This variable displays the supply temperature reading of the air source.

Air Source Supply  
 Temperature:   Units           F (C)  
                   Display Range   -40 to 245  
                   Network Access   None

**START BIAS TIME** — This variable displays the Start Bias Time, in minutes, calculated by the air source. The Start Bias Time is calculated to bring the temperature up or down to the

set point under the optimum start routine. This value will be sent to all associated zones for optimum start of zone controllers. This function is supported by all Carrier equipment which perform linkage.

Start Bias Time:   Display Units   minutes  
                   Display Range   0 to 255  
                   Network Access   None

**OCCUPIED HEAT SET POINT** — This variable displays the weighted average of the occupied heat set point, calculated by the linkage coordinator, from the information received from polling its associated zones. The set points are weighted by the maximum airflow capacities of the zone controllers scanned by the linkage coordinator.

Occupied  
 Heat Set Point:   Display Units   F (C)  
                   Display Range   40.0 to 99.9  
                   Network Access   None

**OCCUPIED COOL SET POINT** — This variable displays the weighted average of the occupied cool set point, calculated by the linkage coordinator, from the information received from polling its associated zones. The set points are weighted by the maximum airflow capacities of the zone controllers scanned by the linkage coordinator.

Occupied  
 Cool Set Point:   Display Units   F (C)  
                   Display Range   45.0 to 99.9  
                   Network Access   None

**UNOCCUPIED HEAT SET POINT** — This variable displays the weighted average of the unoccupied heat set point, calculated by the linkage coordinator, from the information received from polling its associated zones. The set points are weighted by the maximum airflow capacities of the zone controllers scanned by the linkage coordinator.

Unoccupied  
 Heat Set Point:   Display Units   F (C)  
                   Display Range   40.0 to 99.9  
                   Network Access   None

**UNOCCUPIED COOL SET POINT** — This variable displays the weighted average of the unoccupied cool set point, calculated by the linkage coordinator, from the information received from polling its associated zones. The set points are weighted by the maximum airflow capacities of the zone controllers scanned by the linkage coordinator.

Occupied  
 Cool Set Point:   Display Units   F (C)  
                   Display Range   45.0 to 99.9  
                   Network Access   None

**Table 16 — Linkage Maintenance Table**

DESCRIPTION	VALUE	UNITS	STATUS	FORCE	NAME
<b>Zone Linkage</b>					
<b>Air Source Bus #</b>	0				ASBUSNUM
<b>Air Source Element #</b>	8				ASDEVADR
<b>Master Zone Element #</b>	118				MZDEVADR
<b>Operating Mode</b>	COOLING				ASOPMODE
<b>Air Source Supply Temp</b>	55.0	dF			ASTEMP
<b>Start Bias Time</b>	0	min			STRTBIAS
<b>Occ Heat Setpt</b>	68.0	dF			OHS
<b>Occ Cool Setpt</b>	74.0	dF			OCS
<b>Unoc Heat Setpt</b>	64.0	dF			UHS
<b>Unoc Cool Setpt</b>	78.0	dF			UCS
<b>Ref Zone Temp</b>	71.0	dF			ZT
<b>Occ Ref Zone Temp</b>	71.0	dF			OZT
<b>Composite CCN Value</b>	0.0				CCCNVAL
<b>Occupancy Status (1 = occ)</b>	0				OCCSTAT
<b>Next Occupied Day</b>	Fri				NXTOCCD
<b>Next Occupied Time</b>	10:15				NXTOCCT
<b>Next Unoccupied Day</b>					NXTUNOD
<b>Next Unoccupied Time</b>	00:00				NXTUNOT
<b>Prev Unoccupied Day</b>	Fri				PRVUNOD
<b>Prev Unoccupied Time</b>	04:01				PRVUNOT

**REF ZONE TEMPERATURE** — This variable displays the weighted average of the space temperatures, collected by the linkage coordinator, from polling its associated zones. The temperatures are weighted by the maximum airflow capacities of the zone controllers scanned by the linkage coordinator.

Ref Zone

Temperature: Display Units F (C)  
 Display Range -40.0 to 245.0  
 Network Access Read Only

**OCCUPIED REF ZONE TEMPERATURE** — This variable displays the weighted average of the space temperatures of occupied zones, collected by the linkage coordinator, from polling its associated zones. The temperatures are weighted by the maximum airflow capacities of the zone controllers scanned by the linkage coordinator.

Occupied Ref

Zone Temperature: Display Units F (C)  
 Display Range -40.0 to 245.0  
 Network Access Read Only

**COMPOSITE CCN VALUE** — This variable displays the high, low or average of the CCN variable collected from each zone as configured in the Linkage Master (Coordinator) Configuration Screen. The value is sent to the network address and variable specified within that configuration table.

Composite

CCN Value: Display Range 0 to 65535  
 Network Access Read Only

**OCCUPANCY STATUS** — This variable displays a “1” when at least one of the associated zone controllers (that are being scanned) is in the occupied mode.

Occupancy Status: Display Range 0 or 1 (1 = occupied)  
 Network Access Read only

**NEXT OCCUPIED DAY** — This variable displays the day when the next associated zone is scheduled to change from unoccupied to occupied mode. This point is read in conjunction with the next occupied time to allow the user to know the next time and day when a zone will become occupied.

Next Occupied

Day: Display Range MON, TUE, WED,  
 THU, FRI, SAT, SUN  
 Network Access None

**NEXT OCCUPIED TIME** — This variable displays the time of day when the next associated zone is scheduled to change from unoccupied to occupied mode. This point is read in conjunction with the next occupied day to allow the user to know the next time and day when a zone will become occupied.

Next Occupied

Time: Display Range 00:00 to 24:00  
 Network Access None

**NEXT UNOCCUPIED DAY** — This variable displays the day when the next associated zone is scheduled to change from occupied to unoccupied mode. This point is read in conjunction with the next unoccupied time to allow the user to know the next time and day when a zone will become unoccupied.

Next Unoccupied

Day: Display Range MON, TUE, WED,  
 THU, FRI, SAT, SUN  
 Network Access None

**NEXT UNOCCUPIED TIME** — This variable displays the time of day when the next associated zone is scheduled to change from occupied to unoccupied mode. This point is read in conjunction with the next unoccupied day to allow the user to know the next time and day when a zone will become unoccupied.

Next Unoccupied

Time: Display Range 00:00 to 24:00  
 Network Access None

**PREVIOUS UNOCCUPIED DAY** — This variable displays the day when the last associated zone changed from occupied to unoccupied mode. This point is read in conjunction with the previous unoccupied time to allow the user to know the last time and day when a zone became unoccupied.

Previous Unoccupied

Day: Display Range MON, TUE, WED,  
 THU, FRI, SAT, SUN  
 Network Access None

**PREVIOUS UNOCCUPIED TIME** — This variable displays the time of day when the last associated zone changed from occupied to unoccupied mode. This point is read in conjunction with the previous unoccupied day to allow the user to know the last time and day when a zone became unoccupied.

Previous Unoccupied

Time: Display Range 00:00 to 24:00  
 Network Access None

**Master Zone Maintenance Table** — The Master Zone Maintenance Table (MZNMAINT) displays variables used by the Linkage Coordinator zone controller when determining the system mode (heat/cool/vent). It also indicates whether a bypass controller and an air source are being used and which zone is the reference zone. The user may override cooling or heating time guards from this table. See Table 17.

**DESIRED SYSTEM MODE** — This variable will display the desired operating mode of the air source.

Desired

Operating Mode: Display Range COOLING, HEATING, FREECOOL, PRES-SURE, EVAC, OFF  
Network Access Read only

**SYSTEM MODE** — This variable will display the current system mode of the air source, if Linkage is available, or the mode determined by the Linkage Coordinator using the primary air sensor, if available. If the primary air sensor has failed or was not installed, the Linkage Coordinator will assume the default mode of cooling.

System Mode: Display Range COOLING, HEATING, FREECOOL, PRES-SURE, EVAC, OFF  
Network Access Read only

**AIR SOURCE DETECTED** — This variable displays whether the Linkage Coordinator zone controller has detected a communicating air source at the address configured in the Linkage Configuration Table.

Air Source

Detected: Display Range Yes/No  
Network Access Read only

**BYPASS CONTROLLER** — This variable displays whether the Linkage Coordinator zone controller has detected a communicating bypass controller as configured in the Linkage Configuration Table.

Bypass

Controller: Display Range Yes/No  
Network Access Read only

**REFERENCE ZONE DEMAND** — This variable displays the demand of the reference zone. When occupied, the demand will be a function of T56 bias and configured Occupied

Heating and Cooling set points. When in unoccupied mode, the demand will be directly related to configured Unoccupied Heating and Cooling set points.

The reference zone is re-determined on every scan of the zone controllers which is at a one minute frequency.

Reference Zone

Demand: Display Range delta 0.00 to 99.9 F  
Network Access Read only

**REFERENCE ZONE #** — This variable displays the number of the zone whose heating or cooling needs are the greatest at any time and that requires the same mode as the system.

For example, if the Desired System Mode is cooling, the Reference Zone # is that mode that has the greatest cooling need.

The zones are numbered such that the master zone is zone number 1 and the zone that is one address below the master zone is zone number 2 and so on to zone number 32. If the master zone is at address 0, 118 then zone no. 2 is the zone controller at address 0, 117 and zone no. 3 is the zone controller at address 0, 116 and so on.

Reference Zone

Number: Display Range 1 to 32  
Network Access Read only

**COOL MODE LOCK OUT** — This variable displays whether the system has been locked out of cooling mode. If this decision is forced to Yes, the system may not go into cooling mode regardless of how many zones are calling for cooling.

Cool Mode

Lock Out: Display Range Yes/No  
Network Access Read/Write

**AVERAGE COOL DEMAND** — This variable displays the average cooling demand of all occupied linked zones, taking into consideration the size of each zone as configured in the Terminal Service Configuration Table. This is so that the size of a zone will be considered when comparing its demand to other zones. If all zones are unoccupied then all zones will be included in the calculation.

Average Cool

Demand: Display Range delta 0.00 to 99.9 F  
Network Access Read Only

**Table 17 — Master Zone Maintenance Table**

DESCRIPTION	VALUE	UNITS	STATUS	FORCE	NAME
Desired System Mode	COOLING				NEXTMODE
System Mode	COOLING				LINKMODE
Air Source Detected?	Yes				AIRSOURC
Bypass Controller?	No				BYPASS
Reference Zone Demand	0.0	^F			REF_DMD
Reference Zone #	0				REF_ZONE
Cool Mode Lock Out?	No				C_LOCK
Average Cool Demand	0.0	^F			AVGC_DMD
Max Cool Demand	0.0	^F			MAXC_DMD
Max Cool Demand Zone	0				MAXCZONE
Cooling Time Guard	0.0	min			C_TGUARD
Time Guard Override	No				TG_OVRD
Heat Mode Lock Out?	No				H_LOCK
Average Heat Demand	0.0	^F			AVGH_DMD
Max Heat Demand	0.0	^F			MAXH_DMD
Max Heat Demand Zone	1				MAXHZONE
Heating Time Guard	0.0	min			H_TGUARD
Mode Reselect Time	0.0	min			RESELECT
Outdoor Air Temperature	0.0	dF			OAT

**MAX COOL DEMAND** — This variable displays the maximum cooling demand of all occupied linked zones, taking into consideration the size of each zone as configured in the Terminal Service Configuration Table. This is so that the size of the zone will be considered when comparing its demand to other zones.

Max Cool  
Demand:           Display Range   delta 0.00 to 99.9 F  
                    Network Access   Read Only

**MAX COOL DEMAND ZONE** — This variable displays the number of the zone that has the weighted maximum cooling demand of all occupied linked zones. If all zones are unoccupied then all zones will be included in the calculation.

Max Cool  
Demand Zone:    Display Range   0 to 31  
                    Network Access   Read Only

**COOLING TIME GUARD** — This variable displays the remaining time that the cooling mode must be active before a mode change can take effect. The cooling time guard timer becomes active whenever the COOL mode goes into effect. This timer value is configured in the Master Service Configuration Table.

Cooling  
Time Guard:     Display Range   0 to 255 minutes  
                    Network Access   Read Only

**TIME GUARD OVERRIDE** — This variable displays whether there is a time guard override in effect. The override acts as a one time override of any time guard in effect, heating or cooling.

**NOTE:** The time guard override applies to the mode sent to the air source. This is independent of the mode reselect function. Forcing this point to *Yes* will allow the user to initiate a Time Guard Override.

Time Guard  
Override:        Display Range   Yes/No  
                    Network Access   Read/Write

**HEAT MODE LOCK OUT** — This variable displays whether the system has been locked out of heating mode. If this decision is forced to *Yes*, the system may not go into heating mode regardless of how many zones are calling for heating.

Heat Mode  
Lock Out:       Display Range   Yes/No  
                    Network Access   Read/Write

**AVERAGE HEAT DEMAND** — This variable displays the average heating demand of all occupied linked zones, taking into consideration the size of each zone as configured in the Terminal Service Configuration Table. This is so that the size of a zone will be considered when comparing its demand to other zones. If all zones are unoccupied then all zones will be included in the calculation.

Average Heat  
Demand:           Display Range   delta 0.00 to 99.9 F  
                    Network Access   Read Only

**MAX HEAT DEMAND** — This variable displays the maximum heating demand of all occupied linked zones, taking into consideration the size of each zone as configured in the Terminal Service Configuration Table. This is so that the size of the zone will be considered when comparing its demand to other zones.

Max Heat  
Demand:           Display Range   delta 0.00 to 99.9 F  
                    Network Access   Read Only

**MAX HEAT DEMAND ZONE** — This variable displays the number of the zone that has the weighted maximum heating demand of all occupied linked zones. If all zones are unoccupied then all zones will be included in the calculation.

Max Heat  
Demand Zone:     Display Range   0 to 31  
                    Network Access   Read Only

**HEATING TIME GUARD** — This variable displays the remaining time that the heating mode must be active before a mode change can take effect. The heating time guard timer becomes active whenever the HEAT mode goes into effect. This timer value is configured in the Master Service Configuration Table.

Heating  
Time Guard:      Display Range   0 to 255 minutes  
                    Network Access   Read Only

**MODE RESELECT TIME** — This variable displays the remaining time that must elapse before the mode change can take effect. The user can override the timer by forcing this value. This timer value is configured in the Master Service Configuration Table.

Mode Reselect  
Time:             Display Range   0 to 255 minutes  
                    Network Access   Read/Write

**OUTDOOR AIR TEMPERATURE** — This variable displays the outdoor air temperature.

Outdoor Air  
Temperature:     Display Range   –40 to 245 F  
                    Network Access   Read Only

**Time Schedule Maintenance Table** — The Time Schedule Maintenance Table (OCCDEFME) displays occupancy set points, the occupied mode and whether and override is in progress. See Table 18.

**MODE** — This variable displays the current occupied mode for the zone controller. If the zone controller is following its own local schedule, this is the result of the local schedule status.

**NOTE:** This information only applies to the locally configured occupancy schedule or if the zone controller is configured to be the Global Schedule Master. The information does not apply to a zone if it is following a global schedule.

Mode:            Display Range   0 or 1 (1 = occupied)  
                    Network Access   None

**CURRENT OCCUPIED PERIOD** — If the zone controller is configured to determine occupancy locally, this variable will display the current period determining occupancy.

Current Occupied  
Period:           Display Range   1 to 8  
                    Network Access   None

**OVERRIDE IN PROGRESS** — If an occupancy override is in progress, this variable will display a *yes*.

Override In  
Progress:         Display Range   Yes/No  
                    Network Access   None

**OVERRIDE DURATION** — This variable displays the number of minutes remaining for an occupancy override which is in effect. If the number of override hours was downloaded, the value will be converted to minutes.

Override  
Duration:         Display Units   minutes  
                    Display Range   0 to 240  
                    Network Access   None

**OCCUPIED START TIME** — This variable displays the time that the current occupied mode began.

Occupied Start  
Time:             Display Range   00:00 to 23:59  
                    Network Access   None

**Table 18 — Time Schedule Maintenance Table**

DESCRIPTION	VALUE	UNITS	NAME
Mode	1		MODE
Current Occupied Period	2		PERIOD
Override in Progress	No		OVERLAST
Override Duration	0	min	OVERDURA
Occupied Start Time	08:00		OCCSTART
Unoccupied Start Time	18:00		UNSTART
Next Occupied Day	Thu		NXTOCCD
Next Occupied Time	00:00		NXTOCCT
Next Unoccupied Day	Wed		NXTUNOD
Next Unoccupied Time	18:00		NXTUNOT
Last Unoccupied Day			PRVUNOD
Last Unoccupied Time	00:00		PRVUNOT

**UNOCCUPIED START TIME** — This variable displays the time that the current occupied mode will end (the beginning of the next unoccupied mode).

Unoccupied Start  
Time: Display Range 00:00 to 24:00  
Network Access None

**NEXT OCCUPIED DAY** — This variable displays the day when the next occupied period is scheduled to begin. This point is read in conjunction with the next occupied time to allow the user to know the next time and day when the next occupied period will occur.

NOTE: If the current mode is occupied, this point makes reference to the next occupied period and, in most cases, may not be the same as the current occupied start time.

Next Occupied  
Day: Display Range MON, TUE, WED,  
THU, FRI, SAT, SUN  
Network Access None

**NEXT OCCUPIED TIME** — This variable displays the time of day when the next occupied period will occur. This point is read in conjunction with the next occupied day to allow the user to know the next time and day when the zone will become occupied.

NOTE: If the current mode is occupied, this point makes reference to the next occupied period and, in most cases, may not be the same as the current occupied start time.

Next Occupied  
Time: Display Range 00:00 to 24:00  
Network Access None

**NEXT UNOCCUPIED DAY** — This variable displays the day when the next unoccupied period is scheduled to begin. This point is read in conjunction with the next unoccupied time to allow the user to know the next time and day when the zone will become unoccupied.

NOTE: If the current mode is unoccupied, this point makes reference to the next unoccupied period and, in most cases, may not be the same as the current unoccupied start time.

Next Unoccupied  
Day: Display Range MON, TUE, WED,  
THU, FRI, SAT, SUN  
Network Access None

**NEXT UNOCCUPIED TIME** — This variable displays the time of day when the next unoccupied period is scheduled to begin. This point is read in conjunction with the next

unoccupied day to allow the user to know the next time and day when the zone will become unoccupied.

NOTE: If the current mode is unoccupied, this point makes reference to the next unoccupied period and, in most cases, may not be the same as the current unoccupied start time.

Next Unoccupied  
Time: Display Range 00:00 to 24:00  
Network Access None

**LAST UNOCCUPIED DAY** — This variable displays the last day when the zone changed from occupied to unoccupied mode. This point is read in conjunction with the last unoccupied time to allow the user to know the last time and day when the zone became unoccupied.

Last Unoccupied  
Day: Display Range MON, TUE, WED,  
THU, FRI, SAT, SUN  
Network Access None

**LAST UNOCCUPIED TIME** — This variable displays the last time of day when the zone changed from occupied to unoccupied mode. This point is read in conjunction with the last unoccupied day to allow the user to know the last time and day when a zone became unoccupied.

Last Unoccupied  
Time: Display Range 00:00 to 24:00  
Network Access None

**System Commissioning Maintenance Table** — The System Commissioning Maintenance Table (SYSTCOMM) displays and permits the setting of all dampers in the linked system from the Linkage Coordinator zone controller. The bypass controller damper position, system pressure and pressure set point are also displayed and the pressure set point may be altered directly from this table. See Table 19.

**COMMISSIONING MODE** — This variable is used to put the master zone controller into the commissioning mode. Force this point to enable. The Linkage Coordinator zone controller will be ready to accept a command to perform the tests and functions on this screen. The Linkage Coordinator zone controller will go into ZONE\_BAL mode.

NOTE: If this zone controller is not the Linkage Coordinator, enabling this variable will have no effect.

Commissioning  
Mode: Display Range Disable/Enable  
Default Value Disable  
Network Access Read/Write



**POSITION SINGLE ZONE** — This variable displays whether the individual zone positioning process has been enabled. If this decision is forced to *Enable*, the Linkage Coordinator zone controller will set all system zone dampers to their configured Cool Maximum Positions and display the values in Zone (1-32) Damper Position variables.

At this time, if any of the Zone (1-32) Damper Position variables are forced, the zone will be repositioned to this new maximum position. The forced position will be shown on the Zone (1-32) Damper Position variable with a *Supervisor* force. This *Supervisor* force will disappear and the damper's current position will display when the new damper position has been broadcasted to the zone controller's Damper Reference point. The Damper Reference point will display a *Control* force which will remain until System Commissioning is disabled and the Damper Position will go to the new desired position.

NOTE: If this zone controller is not the Linkage Coordinator, enabling this variable will have no effect.

Position  
Single Zone:      Display Range    Enable/Disable  
                         Network Access    Read/Write

**ZONE (1-32) DAMPER POSITION** — This variable displays the current damper position of all system zones during system commissioning. These values can be used to verify and change configured maximum damper positions when All Zone Dampers to Max is Enabled and verify and change configured minimum damper positions when All Zone Dampers to Min is Enabled. The user can also reposition individual zone's dampers when Position Single Zone is Enabled. Force this value to the desired minimum or maximum damper position.

Zone (1-32)  
Damper Position: Display Range    0 to 100%  
                         Network Access    Read/Write

**BYPASS DAMPER POSITION** — This variable displays the bypass damper position.

Bypass  
Damper Position: Display Range    0 to 100%  
                         Network Access    No

**BYPASS PRESSURE SENSOR** — This variable displays the current value of the bypass static system pressure.

Bypass  
Pressure Sensor: Display Range    0.00 to 2.00 in. wg  
                         Network Access    No

**BYPASS PRESSURE SET POINT** — This variable displays the current Bypass Pressure set point. At any time in the system commissioning process, the user can force the Bypass Pressure set point. Typically the maximum unit rated duct velocity pressure would be entered in this decision prior to enabling All Zone Dampers to Maximum. When this value is forced, the new set point is written to the Pressure Set Point Table in the bypass controller over the communication network. The bypass controller then controls to the new bypass pressure set point.

Bypass Pressure  
Set Point:      Display Range    0.00 to 2.00 in. wg  
                         Network Access    Read/Write

**Zone Status Maintenance Table** — The Zone Status Maintenance Table (ZCOMAINT) displays the communication status of the air source, the optional bypass controller, and each of the zone controllers in the 3V™ control system. This table is only active in the Linkage Coordinator zone controller. See Table 20.

**AIR SOURCE STATUS** — This variable displays the communication status of the air source.

NOTE: If the zone controller is not a Linkage Coordinator, the status will be NONE.

Air Source  
Status:            Display Range    Com OK, None, Failed

**BYPASS COMM STATUS** — This variable displays the communication status of the bypass damper controller.

NOTE: If the zone controller is not a Linkage Coordinator, the status will be NONE.

Bypass Com  
Status:            Display Range    Com OK, None, Failed

**ZONE (1-32) COMM STATUS** — This variable displays the communication status of each zone controller.

NOTE: If the zone controller is not a Linkage Coordinator, the status will be NONE.

Zone (1-32)  
Comm Status:      Display Range    Com OK, None, Failed

**Zone Device Maintenance Table** — The Zone Device Maintenance Table (ZDEVMAIN) displays the type of device found at each address in the 3V control system beginning with the device found at the address that is one element higher than the Linkage Coordinator zone controller, decrementing by 1 until the configured number of zones have been checked. This table is only active in the Linkage Coordinator zone controller. See Table 21.

**BYPASS DEVICE TYPE** — This variable displays the type of device found at the location where there is typically a bypass controller. This location is one address higher than the Linkage Coordinator zone controller. Valid displays for this variable are:

- None = No device present/com. fail/ pending
- Master = Linkage Coordinator found (typically found at ZD\_DEV01 only)
- Bypass = bypass controller
- PDZone = pressure dependent zone
- PIZone = pressure independent zone
- Other = other Carrier Network device found

NOTE: If this zone controller is not a Linkage Coordinator, the value of this display will be *None*.

**ZONE (1-32) DEVICE TYPE** — This variable displays the type of device found when the master scans zones 1 through n where n is the number of zones (1-32) configured in the Number of Zones decision in the Linkage Configuration Table. The zones are scanned in descending order, beginning with the Linkage Coordinator itself at zone n.

Valid displays for this variable are:

- None = No device present/com. fail/pending
- Master = Linkage Coordinator found (typically found at ZD\_DEV01 only)
- Bypass = bypass controller
- PDZone = pressure dependent zone
- PIZone = pressure independent zone
- Other = other Carrier Network device found

NOTE: If this zone controller is not a Linkage Coordinator, the value of this display will be *None*.

**Zone Maintenance Table** — The Zone Maintenance Table (ZNMAINT) displays the status of the air source (heating, cooling, ventilation) and the reference values that the zone is using for control. This table also displays whether this zone is the Linkage Coordinator, whether there is an override in effect, and whether there are any loadshed conditions currently in effect. See Table 22.

**OCCUPIED** — This variable displays the current occupied mode for the zone controller. If the zone controller is following its own local schedule, this is the result of the local schedule status. If the zone controller is configured to follow a global schedule, this displays the mode last received from a global schedule broadcast.

Occupied:            Display Range    No/Yes  
                         Network Access    Read Only

**LINKAGE ZONE** — This variable displays if air source linkage is in effect.

Linkage Zone:      Display Range    No/Yes  
                         Network Access    Read Only

**Table 20 — Zone Status Maintenance Table**

DESCRIPTION	VALUE	UNITS	STATUS	FORCE	NAME
<b>Air Source Status</b>	Failed				AIRSRCE
<b>Bypass Comm Status</b>	Failed				ZD_CS00
<b>Zone 1 Comm Status</b>	Com OK				ZD_CS01
<b>Zone 2</b>	None				ZC_CS02
<b>Zone 3</b>	None				ZC_CS03
<b>Zone 4</b>	None				ZC_CS04
<b>Zone 5</b>	None				ZC_CS05
<b>Zone 6</b>	None				ZC_CS06
<b>Zone 7</b>	None				ZC_CS07
<b>Zone 8</b>	None				ZC_CS08
<b>Zone 9</b>	None				ZC_CS09
<b>Zone 10</b>	None				ZC_CS10
<b>Zone 11</b>	None				ZC_CS11
<b>Zone 12</b>	None				ZC_CS12
<b>Zone 13</b>	None				ZC_CS13
<b>Zone 14</b>	None				ZC_CS14
<b>Zone 15</b>	None				ZC_CS15
<b>Zone 16</b>	None				ZC_CS16
<b>Zone 17</b>	None				ZC_CS17
<b>Zone 18</b>	None				ZC_CS18
<b>Zone 19</b>	None				ZC_CS19
<b>Zone 20</b>	None				ZC_CS20
<b>Zone 21</b>	None				ZC_CS21
<b>Zone 22</b>	None				ZC_CS22
<b>Zone 23</b>	None				ZC_CS23
<b>Zone 24</b>	None				ZC_CS24
<b>Zone 25</b>	None				ZC_CS25
<b>Zone 26</b>	None				ZC_CS26
<b>Zone 27</b>	None				ZC_CS27
<b>Zone 28</b>	None				ZC_CS28
<b>Zone 29</b>	None				ZC_CS29
<b>Zone 30</b>	None				ZC_CS30
<b>Zone 31</b>	None				ZC_CS31
<b>Zone 32</b>	None				ZC_CS32



**Table 21 — Zone Device Maintenance Table**

DESCRIPTION	VALUE	UNITS	STATUS	FORCE	NAME
Bypass Device Type	Bypass				ZD_DEV00
Zone 1 Device Type	Master				ZD_DEV01
Zone 2	PD Zone				ZD_DEV02
Zone 3	PD Zone				ZD_DEV03
Zone 4	None				ZD_DEV04
Zone 5	None				ZD_DEV05
Zone 6	None				ZD_DEV06
Zone 7	None				ZD_DEV07
Zone 8	None				ZD_DEV08
Zone 9	None				ZD_DEV09
Zone 10	None				ZD_DEV10
Zone 11	None				ZD_DEV11
Zone 12	None				ZD_DEV12
Zone 13	None				ZD_DEV13
Zone 14	None				ZD_DEV14
Zone 15	None				ZD_DEV15
Zone 16	None				ZD_DEV16
Zone 17	None				ZD_DEV17
Zone 18	None				ZD_DEV18
Zone 19	None				ZD_DEV19
Zone 20	None				ZD_DEV20
Zone 21	None				ZD_DEV21
Zone 22	None				ZD_DEV22
Zone 23	None				ZD_DEV23
Zone 24	None				ZD_DEV24
Zone 25	None				ZD_DEV25
Zone 26	None				ZD_DEV26
Zone 27	None				ZD_DEV27
Zone 28	None				ZD_DEV28
Zone 29	None				ZD_DEV29
Zone 30	None				ZD_DEV30
Zone 31	None				ZD_DEV31
Zone 32	None				ZD_DEV32

**Table 22 — Zone Maintenance Table**

DESCRIPTION	VALUE	UNITS	STATUS	FORCE	NAME
Occupied	Yes				ZONE_OCC
Linkage Zone	No				LINKSLAV
Linkage Master	Yes				LINKMAST
Timed Override in Effect	No				TIMOV
Setpoint Offset (T-56)	0.0	^F			T56OFF
Cool Master Reference	74.0	dF			CCMR
Damper Reference	0	%			PDSMR
Supp. Heat Lockout	No				SH_LOCK
Heat Master Reference	70.0	dF			HCMR
Heat Submaster Reference	110	dF			HSMR
Temp Control Position	0	%			TC_DPOS
DCV Damper %	0	%			DCVD
Cooling in Effect	No				COOLFLAG
Heating in Effect	Yes				HEATFLAG
DCV in Effect	No				DCVFLAG
Clear Alarms	No				CLR_ALRM
Loadshed Function					
Redline	No				REDLINE
Loadshed	No				LOADSHED
Loadshed Timer	0	min			LOADTIME

LINKAGE MASTER — This variable displays if this zone controller is functioning as a Linkage Coordinator.

Linkage Master: Display Range No/Yes  
Network Access Read Only

TIMED OVERRIDE IN EFFECT — This variable indicates if a timed override is in effect.

Timed Override in Effect: Display Range No/Yes  
Network Access Read Only

SET POINT OFFSET (T-56) — This variable displays the degrees of offset when using a 33ZCT56SPT space temperature sensor with set point adjustment. The slidebar on the sensor will adjust the desired temperature in that zone, up or down, when it is moved. The Set Point Offset (T-56) variable can disable set point offset (set to 0).

Set Point Offset (T-56): Display Units delta F (delta C)  
Display Range -15.0 to 15.0  
Network Access Read/Write

COOL MASTER REFERENCE — This variable displays the cooling master reference from the set point schedule. This should be the occupied cool set point when the zone is in occupied mode or the unoccupied cool set point when the zone is in unoccupied mode. This variable will display any space temperature sensor slidebar offset that is being applied.

Cool Master Reference: Display Units F (C)  
Display Range 45.0 to 99.9  
Network Access Read/Write

DAMPER REFERENCE — This variable displays the current damper reference position.

Damper Reference: Display Units % (open)  
Display Range 0 to 100  
Network Access Read/Write

SUPPLEMENTAL HEAT LOCKOUT — This variable displays if Supplemental Heat is locked out by the outside air temperature or if forced. If this variable is set to Yes, then Supplemental Heat is locked out.

Supplemental Heat Lockout: Display Range No/Yes  
Default No  
Network Access Read/Write

HEAT MASTER REFERENCE — This point displays the occupied heat set point if occupied, or the unoccupied heat set point if unoccupied. This variable will display any space temperature sensor slidebar offset that is being applied.

Heat Master Reference: Display Units F (C)  
Display Range 40.0 to 90.0  
Network Access Read/Write

HEAT SUBMASTER REFERENCE — If heat is enabled, this variable displays the desired supply air temperature calculated to heat the space. This is a result of the heating PID loop calculation.

Heat Submaster Reference: Display Units F (C)  
Display Range 0 to 240  
Network Access Read/Write

TEMPERATURE CONTROL POSITION — This variable displays the airflow set point determined from the temperature loop calculation. The zone controller compares the temperature demand and DCV loops. The greatest of the two will become the primary damper airflow reference.

Temperature Control Position: Display Units %  
Display Range 0 to 100  
Network Access Read Only

DCV DAMPER % — This variable displays the damper set point determined by the demand control ventilation loop calculation. The zone controller compares the demand of the temperature and demand control ventilation loops. The greatest of the two will become the Damper Reference.

DCV Damper %: Display Units %  
Display Range 0 to 100  
Network Access Read Only

COOLING IN EFFECT — This variable displays if the air source is in the Cooling mode and if the terminal is using the cooling damper set points.

Cooling In Effect: Display Range No/Yes  
Network Access Read Only

HEATING IN EFFECT — This variable displays if the air source is in the Heat mode and if the terminal is using the heating damper set points.

Heating In Effect: Display Range No/Yes  
Network Access Read Only

DCV IN EFFECT — This variable indicates if the DCV control is active.

DCV In Effect: Display Range No/Yes  
Network Access Read Only

CLEAR ALARMS — This variable displays the commanded state of the Clear Alarms function. If this decision is forced to Yes, all alarms in the Alarm History Table will be cleared and this decision will automatically be set back to No.

Clear Alarms: Display Range No/Yes  
Network Access Read/Write

LOADSHED FUNCTION REDLINE — This variable displays whether the zone controller is currently participating in a redline event and as a result has relaxed its current set points by the amount configured in the Options Configuration Table.

Redline: Display Range No/Yes  
Network Access Read Only

LOADSHED — This variable displays whether the zone controller is currently participating in a loadshed event. If the loadshed event was preceded by a redline event and was in redline when the loadshed command was received, then the zone controller will drop one stage of heat if in heating mode and provided there is more than one stage available. If in cooling mode, the zone controller will raise the cooling set point by the amount configured in the Options Configuration Table, if this will cause the space to be satisfied.

Loadshed: Display Range No/Yes  
Network Access Read Only

LOADSHED TIMER — This variable displays the timer that is started during a redline or loadshed event to automatically timeout the event after a user programmable time limit. The time limit is configurable in the Option Service Configuration Table.

NOTE: The redline/loadshed response will be automatically cancelled upon termination of the current occupied period.  
Loadshed Timer: Display Range 0 to 240 min  
Network Access Read Only

**Zone Commissioning Maintenance Table** — The Zone Commissioning Maintenance Table (ZONECOMM) displays and permits the setting of damper position for the purpose of damper actuator transducer calibration. It also allows the user to test the fan on series and parallel fan powered terminals and to test the heat outputs. It displays the supply air temperature for the heat test and will display an alarm if the calibration fails. See Table 23.

**Table 23 — Zone Commissioning Maintenance Table**

DESCRIPTION	VALUE	UNITS	STATUS	FORCE	NAME
Commissioning Mode	Disable				CMODE
Damper Cal	Disable				CALIBRAT
Fan Override	Disable				FANOVER
Heating Override	Disable				HEATOVER
Damper Position	10	%OPEN			DMPPPOS
Supply Air Temperature	67.1	dF			SAT
Damper Cal Status	Normal				CAL_ALRM

COMMISSIONING MODE — This variable is used to put the zone controller into the commissioning mode. Force this point to enable. The zone controller will be ready to accept a command to perform the tests and functions on this screen.

NOTE: Commissioning mode will automatically be disabled after one hour.

**Commissioning**

Mode:            Display Range    Disable/Enable  
                   Default Value    Disable  
                   Network Access    Read /Write

→ DAMPER ACTUATOR CALIBRATION — The Damper Actuator calibration is the first calibration which should be performed on a newly installed actuator. The zone controller will command the actuator to close and read the feedback potentiometer to determine the zero position of the damper. It will then command the damper to fully open. The zone controller will read the potentiometer to determine the maximum open position. Damper positions from closed to maximum open will be scaled to read 0 to 100% for the damper position.

The entire calibration procedure can take up to 3 minutes. If the damper fails the test, the Auto-Calibration point will indicate an Alarm.

**Damper Actuator**

Calibration:    Display Range    Disable/Enable  
                   Default Value    Disable  
                   Network Access    Read /Write

FAN OVERRIDE — This variable can be used to test the fan on series and parallel fan powered terminals. Enabling this point will cause the terminal fan to run until this point is disabled or the commissioning mode is ended.

Fan Override:    Display Range    Disable/Enable  
                   Default Value    Disable  
                   Network Access    Read /Write

HEATING OVERRIDE — This variable can be used to test the heat outputs. Enabling this variable will cause the heat to be modulated or staged to full heat until this point is disabled or the force released. Ducted reheat operation will be controlled so as not to exceed the configured maximum duct temperature. The supply-air temperature is included on this screen to verify that the heat is operating.

Heating Override: Display Range    Disable/Enable  
                   Default Value    Disable  
                   Network Access    Read /Write

DAMPER POSITION — This variable displays the current damper position. During CFM Balancing, this variable is used to display the position of the damper. This value can be used to see if the damper is fully open and the system air is sufficient.

**Damper**

Position:        Display Units    % (open)  
                   Display Range    0 to 100  
                   Default Value    100  
                   Network Access    Read Only

SUPPLY-AIR TEMPERATURE — This variable displays the supply-air temperature for ease of verifying the heat operation during the heat test.

**Supply-Air**

Temperature:    Display Units    F (C)  
                   Display Range    -40.0 to 245.0  
                   Default Value    0.0  
                   Network Access    Read /Write

→ DAMPER CALIBRATION STATUS — This variable will display “Normal” if the actuator calibration is successful. If damper or transducer calibration was not successful, this point will display “Alarm” and the zone controller will broadcast the appropriate alarm (if configured to transmit alarms).

**Damper**

Calibration Status: Display Range    Normal/Alarm  
                           Default Value    Normal  
                           Network Access    Read Only

**OPERATION**

**System Mode Selection** — The Linkage Coordinator will determine whether the system as a whole requires heating or cooling and whether the air source will operate in occupied or unoccupied mode. This will be determined by obtaining the heating or cooling needs of each zone and adjusting for the duct size of the zones and calculating an average cool demand (ACD) and average heat demand (AHD) as well as its occupancy mode. The Linkage Coordinator will be the highest addressed zone controller of all zones that are served by the same air source equipment and it will obtain this information when it scans all its associated zones on approximately 1-minute intervals.

When using the Occupied Heating Set Point (OHS) or Occupied Cooling Set Point (OCS) the actual configured values will be used including T56 biased offset (if present) as the zone operating set points. The T56 bias is not applied to Unoccupied Heating and Cooling Set Points.

Temperature demand will be used to indicate individual zone demand and for accumulating the total weighted average demand for heating and for cooling. If the space temperature (SPT) is greater than the OCS then the zone demand is cooling and the space temperature will be used in the ACD. If the SPT is less than the OHS than the zone demand will be heating and the space temperature will be used in the AHD. If the SPT is between the OHS and OCS, the zone will be considered to have no demand and will not be included in determining the system mode. Only those zones with a valid SPT of greater than -40 F, less than 245 F, and a configured damper size greater than 0 will be included in the calculations.

If any zone is occupied then the Linkage Coordinator will calculate the ACD and AHD using only the occupied zones. If no zones are occupied will then the Linkage Coordinator will calculate the ACD and AHD including all zones in the calculation. The zone controller then display the ACD, the Max Cool Demand and Max Cool Demand Zone, the AHD, the Max Heat Demand Max Cool Demand Zone, the Reference Zone Demand and Zone Identification for each demand in the Master Zone maintenance table.

If no mode is currently active, the Linkage Coordinator will determine the mode by first comparing the AHD and the ACD. If only one demand is greater than the start demand (Heat Start Avg. Demand or Cool Start Avg. Demand in the Master [Linkage Coordinator] Service Configuration table), the system will start in that mode. If both average demands are greater than the configured minimum average demand required to begin a mode, then the mode with the greatest demand will be selected. If both heating and cooling average demand are exactly the same then the mode with the greatest individual zone demand will determine the system mode.

Once the mode is selected, the information is communicated to its air source via the Linkage Coordinator so that the air source may respond to the requested mode. The Linkage Coordinator also has the capability of locking out the mode based on the outside air temperature (OAT). If the OAT has exceeded the lockout set point for that mode, then the Linkage Coordinator will not request that mode from the air source. There is a fixed 3° F hysteresis on the heating and cooling set points before a mode is re-enabled.

Once a mode has begun, the system mode reselect timer is started to monitor the elapsed time of the operating mode. A mode will end when the average demand for that mode drops below the average demand hysteresis for the mode (Heat Mode Hysteresis or Cool Mode Hysteresis in the Master [Linkage Coordinator] Service Configuration table). If a system mode is currently active and the average demand for the opposite mode becomes greater than the current mode average demand, and the opposite mode demand is also greater than the mode Start Avg. Demand for that mode, then the system mode may change but only after the system mode reselect time of the current mode exceeds the configured System Mode Reselect timer value. If these are all true, the system will begin the change to the opposite system mode. This is accomplished by sending information to the air source that ends the current mode. The Linkage Coordinator then waits for the supply-air temperature (SAT) to fall within the ventilation temperature range of 65 to 75 F. Once that occurs, the opposite mode is started.

If the mode is dropped due to the reselection criteria above, the algorithm will not permit the original mode to be re-established unless there is sufficient average demand to start the new mode. This is true even if the old mode has once again become the more dominant requirement.

**Linkage** — Linkage is the process used to communicate between the air source (HVAC equipment) and the zone terminals to form a coordinated HVAC system. Linkage allows the

air source to be controlled by the demands of the zones and allows the zones to properly respond to the changes in the air source operating modes. Linkage operation in air sources that have Carrier communicating network controls such as 48/50HG, 48/50A, and 48/50Z Product Integrated Controls (PIC) series rooftop units, PremierLink™ control or Universal Controller is supported. Existing air sources that do not have Carrier communicating network controls may be retrofitted with PremierLink or a Universal Controller depending on the equipment type. The designated Linkage Coordinator of each system will be the Linkage Coordinator between the air source and its associated zones.

**AIR SOURCES THAT SUPPORT LINKAGE** — Air sources with PICs or PremierLink controls do not require any configuration settings to establish linkage with the Linkage Coordinator. This is done automatically when the air source bus and element address are configured in the Linkage Coordinator’s LINKAGE configuration table. The linkage information that is supplied to the air source by the Linkage Coordinator is as follows:

- Reference zone temperature
- Reference zone occupied biased heating and cooling setpoints
- Average unoccupied heating and cooling set points of all zones serviced by the air source
- Composite occupancy mode

The air source will control the equipment based on this information and in return will provide the Linkage Coordinator with the following data:

- Operating mode — Cooling, Heating, Free Cool, Pressure, Evacuation or Off
- Supply-air temperature

This synchronization of data optimizes the efficiency of the air source and the zones to operate at peak system performance at all times. This information can be seen in linkage maintenance tables of the Linkage Coordinator and the air source and is updated at approximately 1-minute intervals.

The reference zone temperature that is sent by the Linkage Coordinator will vary depending on the current demand. At times this will be a calculated value instead of an actual value to allow the air source to turn off heating or cooling after the current mode is satisfied or as it makes a transition to a mode. Table 24 defines when these values will be sent and how they are determined.

**Table 24 — Occupied Reference Zone Value**

SYSTEM DESIRED MODE	OCCUPIED REFERENCE ZONE TEMPERATURE (OZT)	SYSTEM MODE CONDITION
COOLING	OZT = RZSPT	ACD >= Avg Cool Start Demand and system is in Cooling
	OZT = RZHSP	Heating mode has just satisfied (AHD < (Avg Heat Start Demand – Heat Mode Hysteresis)). Fan will continue to run if configured for continuous fan operation
HEATING	OZT = RZSPT	AHD >= Avg Heat Start Demand and system is in Heating
NONE	OZT = RZCSP	Cooling mode has just satisfied (ACD < (Avg Cool Start Demand – Cool Mode Hysteresis)). Fan will continue to run if configured for continuous fan operation
	OZT = (RZCSP – RZHSP) + RZCSP	RZSPT is less than RZCSP and greater than RZHSP. No demand for heat or cool.
	OZT = 0	1) System in unoccupied modes. 2) System is occupied, there is no demand for heat or cool and fan operation is configured for intermittent. 3) System is occupied and bypass pressure sensor calibration is in progress.
C_FLUSH, H_FLUSH	OZT = (RZCSP – RZHSP) + RZCSP	System Mode Reselect is in effect and has timed out. The previous mode has ended and system is transitioning to the opposite mode.

**LEGEND**

- ACD — Average Cool Demand
- AHD — Average Heat Demand
- RZSPT — Reference Zone Space Temperature (actual)
- RZCSP — Reference Zone Cool Set Point
- RZHSP — Reference Zone Heat Set Point

**NON-LINKAGE CONTROLLED AIR SOURCES** — In systems with Non-Linkage central air sources or central air sources that do not support Linkage, the zone coordination function of Linkage can still be provided by the Linkage function contained within a Linkage Coordinator. In these cases, the zone configured as the Linkage Coordinator will determine the operational mode of the air source through its bypass controller pressure sensor. Once the air source is determined to be operational, the Linkage Coordinator will attempt to determine the air source mode (heating or cooling) by measuring the supply air temperature from the air source by either a primary air temperature sensor or a bypass duct temperature sensor. A field-supplied primary air temperature sensor is required.

The modes that can be determined are Cooling, Heating, Free Cooling, or Off. If a sensor is not installed, or the sensor fails, then the Linkage Coordinator will default to the cooling mode. The mode and air source status is then transmitted down to the zones by the Linkage Coordinator.

**NOTE:** If Linkage communication should fail between a linked air source and its Linkage Coordinator for more than 5 minutes, the Linkage Coordinator will generate a Linkage Failure alarm and will revert back a Non-Linkage air source control. Once Linkage communication has been re-established it will automatically begin controlling the air source.

**System Modes** — The following modes are determined by the Linkage Coordinator through the Linkage data exchange when there is a linked, controlled air source or by using its bypass controller and primary air sensor if there is a non-linkage controlled air source. Some modes will not be available if there is a non-Linkage controlled air source. All the listed modes are available if there is a linked Carrier communicating network controlled air source depending on the available input options of the of the air source. Each mode description identifies if and how that mode is determined if there is a non-linkage controlled air source.

**OFF MODE** — The linked air source will determine this mode based on its fan status input under normal operating conditions. For a non-Linkage controlled air source, the Linkage Coordinator will determine if the air source is operational (the fan is on) by determining if the bypass pressure can be measured. If no pressure can be measured then the Linkage Coordinator controller concludes that the air source is off and all zone dampers will go to 70% open. If pressure is measured, then the Linkage Coordinator concludes that the air source is on. If no bypass controller is present then the system will be considered to be always on.

**HEAT MODE** — The linked air source is in heat mode due to a request for from Linkage Coordinator. For a non-Linkage controlled air source, when the fan is determined to be on, the Linkage Coordinator controller reads the primary air temperature value. If the duct temperature is 5° F greater than the reference zone temperature and the reference zone is greater than 65 F, or if the reference zone is less than 65 F and the duct temperature is 10° F greater than the reference zone temperature, then the mode is determined to be heating.

**COOL MODE** — The linked air source is in cool mode due to a request for from Linkage Coordinator. For a non-linkage controlled air source, when the fan is determined to be on, the Linkage Coordinator controller reads the primary air temperature value. If the temperature is less than the reference zone temperature, as calculated by the Linkage Coordinator controller, minus 2° F, the mode is determined to be cooling.

**FREECOOL MODE** — The following conditions must be present in the linked air source for free cooling mode:

- the average zone temperature value is greater than the average unoccupied zone cooling temperature set point
- the current time is between 3:00 AM and 7:00 AM
- the air source is providing cooling to the system

If the above conditions are true, then the mode is determined to be Free Cooling. This mode is then communicated to all zone controllers associated (linked) with the Linkage Coordinator controller. For a non-Linkage controlled air source, this will be same as COOL mode if the criteria for COOL mode is met as described above.

**PRESSURIZATION MODE** — If the linked air source has its optional Pressurization input closed, it will transmit this mode to the Linkage Coordinator. If this mode is active then all zones will open the dampers to the cooling maximum damper position, series fan boxes will have their fans forced on and parallel fan boxes will have their fan forced off. This mode is not available for if there is a non-Linkage controlled air source.

**EVACUATION MODE** — If the linked air source has its optional Fire Shutdown or Evacuation input closed, it will transmit this mode to the Linkage Coordinator. If this mode is active then all zone dampers will be fully closed and series and parallel fan boxes will have their fans forced off. This mode is not available for if there is a non-Linkage controlled air source.

**Air Terminal Modes** — Once the system mode is established the terminals will control their dampers to maintain the zone temperature in the space. Table 25 list a brief description of their operation. For a detail description of the terminal modes and their operation, refer to the 3V™ Control System Application manual.

**Table 25 — Air Terminal Modes**

AIR TERMINAL OPERATING MODE	AS DISPLAYED IN POINTS STATUS TABLE	AIR TERMINAL ACTION
OFF	OFF	No active control of temperature or Cfm in the zone.
VENT	VENT	Temperature requirement of the zone is satisfied. Minimum cooling or ventilation position (which ever is greater) is maintained.
COOL	COOL	Zone Controller is attempting to cool the zone by using supply air.
DCV	COOL or VENT	Zone Controller is attempting to increase zone ventilation by overriding temperature control damper position requirements. System must be in cooling or ventilation mode.
HEAT	HEAT	Zone Controller is attempting to heat the zone by using supply air or local heating if configured for series or parallel fan terminal.
REHEAT	REHEAT	Zone Controller is attempting the heat the zone by locally re-heating the supply air (single duct terminal only).
PRESSURE*	PRESSURE	Zone Controller is participating in the pressurization by forcing damper to max cooling position and turning on fan if configured for series fan terminal.
EVACUATION*	EVAC	Zone Controller is participating in the evacuation by forcing damper to closed and turning off fan if configured for series or parallel fan terminal.
COMMISSIONING	COMMISS	Zone damper is in the process of calibrating its damper.
ZONE BALANCING	ZONE_BAL	Zone damper position is being overridden by its Linkage Coordinator's system balancing mode.

\*Systems with linkage controlled air source only.

The zone controller can be configured for one of three types of air terminal control - single duct, series fan or parallel fan. If configured for parallel fan, the fan will be energized whenever there is a demand for heat the system mode is not Heating and when there is a demand for heat when the zone is unoccupied and the system mode is not Heating. If configured for series fan, the fan will be energized whenever the zone is occupied and when there is a demand for heat when it is unoccupied. To prevent all series fan zones from starting at one time, the zone controller will run a start delay algorithm based on the zone controllers address to stagger the fan start time. Before starting the fan is started the zone damper will go to the fully closed position to prevent the fan from starting backwards. The following formula is used to delay the fan start in second:

Delay time in seconds = (((Whole Remainder of Element#/20)\*60)+20)

**ZONE DAMPER TEMPERATURE CONTROL** — The damper will modulate to adjust the airflow to the space to maintain its current set point. The damper is controlled by a PID loop to provide precise control of the damper position. The damper will be modulated opened if the system mode and local mode are the same. As the zone temperature gets closer to the set point, the damper will modulate to the Minimum Damper Position. The amount the damper will be open at any given time depends on how far away the temperature is from the set point, how fast it takes to satisfy the mode, and the Minimum and Maximum Positions for current mode. Once the zone is satisfied the damper will go to its Minimum Damper Position for that mode. Cool/Heat Minimum and Maximum Positions are defined in the Damper service configuration table.

If the local zone temperature is different from the system mode then the damper will be at Minimum Position for the system mode.

**ZONE DAMPER REHEAT** — If the zone controller has optional reheat installed, it will use this heat to maintain the heating set point. There are 4 types of heat options available as listed below:

- Modulating hot water or steam (requires a supply air temperature [SAT] sensor for ducted heat or a leaving water temperature sensor for baseboard heat)
- Two-position hot water or steam (SAT required)
- 1 to 3 stages of electric heat (SAT required)
- Combination of staged baseboard and ducted heat (SAT required)

If the zone controller is configured for single duct terminal, the system mode is cooling, and the zone local mode is heating the damper will go to the configured Reheat Minimum Position or the Cool Minimum Damper Position (as configured in the Damper service configuration table) whichever is greater, and reheat will be energized.

If the zone controller is configured for series or parallel fan terminal the zone controller will close the damper to the Cool Minimum Position before energizing the reheat. For parallel zone terminals the fan will be energized as the first stage of heat. The zone controller uses a PID algorithm to calculate a supply air or leaving water temperature, which the reheat will be controlled to, in order to satisfy the heat demand.

If the system mode is Heating, the zone controller will try to heat the zone with the central heat but may energize reheat to satisfy the demand if it is required. If the terminal type is configured for parallel fan the fan will remain off. If no reheat is desired in the zone while central heat is on or under any

other specific conditions, it can be disabled by forcing the Heat point in the Status Display table to Disable. Contact your local Carrier Controls representative if you need assistance with this application.

**ZONE DAMPER VENTILATION** — After the zone has satisfied and the system mode is Cooling or Free Cooling and the SAT is between 65 and 75 F, the damper will go to its Ventilation Position or the Cool Minimum Position, whichever is greater. If the SAT is less than 65 or greater than 75 or the system mode changes to Heating, the damper go to the current system mode Minimum Position. The Ventilation Damper Position is defined in the Damper service configuration table.

**DEMAND CONTROL VENTILATION (DCV)** — If the zone controller has a CO<sub>2</sub> Demand Ventilation sensor it will be able to override the temperature controlled damper position if it is occupied, the system mode is Cooling or Free Cool, and the zone is does not have a demand for heat. When the IAQ sensor exceeds the configured Demand Vent set point it will use a PID algorithm to calculate a higher damper position to allow more airflow to the zone in order to dilute the CO<sub>2</sub> levels. The Demand Ventilation algorithm has a higher priority than the temperature control algorithm under these conditions so the damper will be controlled to the greater of the two values. The DCV mode, when active, overrides the Cool Minimum and Ventilation Positions. As the CO<sub>2</sub> levels decrease in the zone the damper will soon be returned to normal temperature control.

If the zone is configured for modulating ducted reheat and the zone temperature decreases to less than half way between the heat and cool set point then the reheat will be enabled to prevent the zone from going into the heat mode. If the zone is configured for any other type of reheat it will NOT be energized. If the temperature continues to decrease below the heat set point, the DCV mode will be disabled and the zone will resume normal temperature control.

The zone ZNMAINT maintenance status table will display the calculated damper position and if the temperature or DCV is in control of the damper as well as other information such as occupancy status, heat and cool set points, reheat sub-master reference and whether local heating or cooling is in effect.

**LOADSHED** — The zone controller can respond to a redline or loadshed broadcast from an optional Loadshed module installed on the Carrier communicating network. The purpose of this function is to monitor and conserve electrical power usage. If a redline command is broadcast the zone controller expand its heat and cool set points by the amount that is configured in Loadshed Offset Adjust decision in the OPTIONS service configuration table. The default is 2° F so this amount would be subtracted from the heat set point and added to the cool set point if is left unchanged. A configurable redline/loadshed delay timer (Maximum Loadshed Time decision in the OPTIONS service configuration) will also started to prevent the set points from being expanded indefinitely.

If a Loadshed command is broadcast then the set points will be expanded and the zone controller will drop 1 stage of reheat providing that the reheat option is enabled and there is more than one stage of heat. The set points will be returned to normal and additional staged heat will be allowed when the redline/loadshed command is canceled by the Loadshed Module, the zone controller's internal redline/loadshed delay timer times out or the zone becomes unoccupied. Contact your local Carrier Controls representative for more information on this application.

# APPENDIX A — SYSTEM OPERATION FLOW CHARTS

## → 3V™ System Mode Selection

### LEGEND

- ACD — Avg Cool Demand
- AHD — Avg Heat Demand
- CLO\_SPT — OAT Cooling Lockout Setpoint
- CSA\_DMD — Cool Start Avg. Demand
- C\_HYST — Cool Demand Hysteresis
- HLO\_SPT — OAT Heating Lockout Setpoint
- HSA\_DMD — Heat Start Avg. Demand
- H\_HYST — Heat Start Hysteresis
- OAT — Outside Air Temperature
- OZT — Occupied Zone Temperature
- RZCSP — Reference Zone Cool Setpoint
- RZHSP — Reference Zone Heat Setpoint
- RZSPT — Reference Zone Space Temp

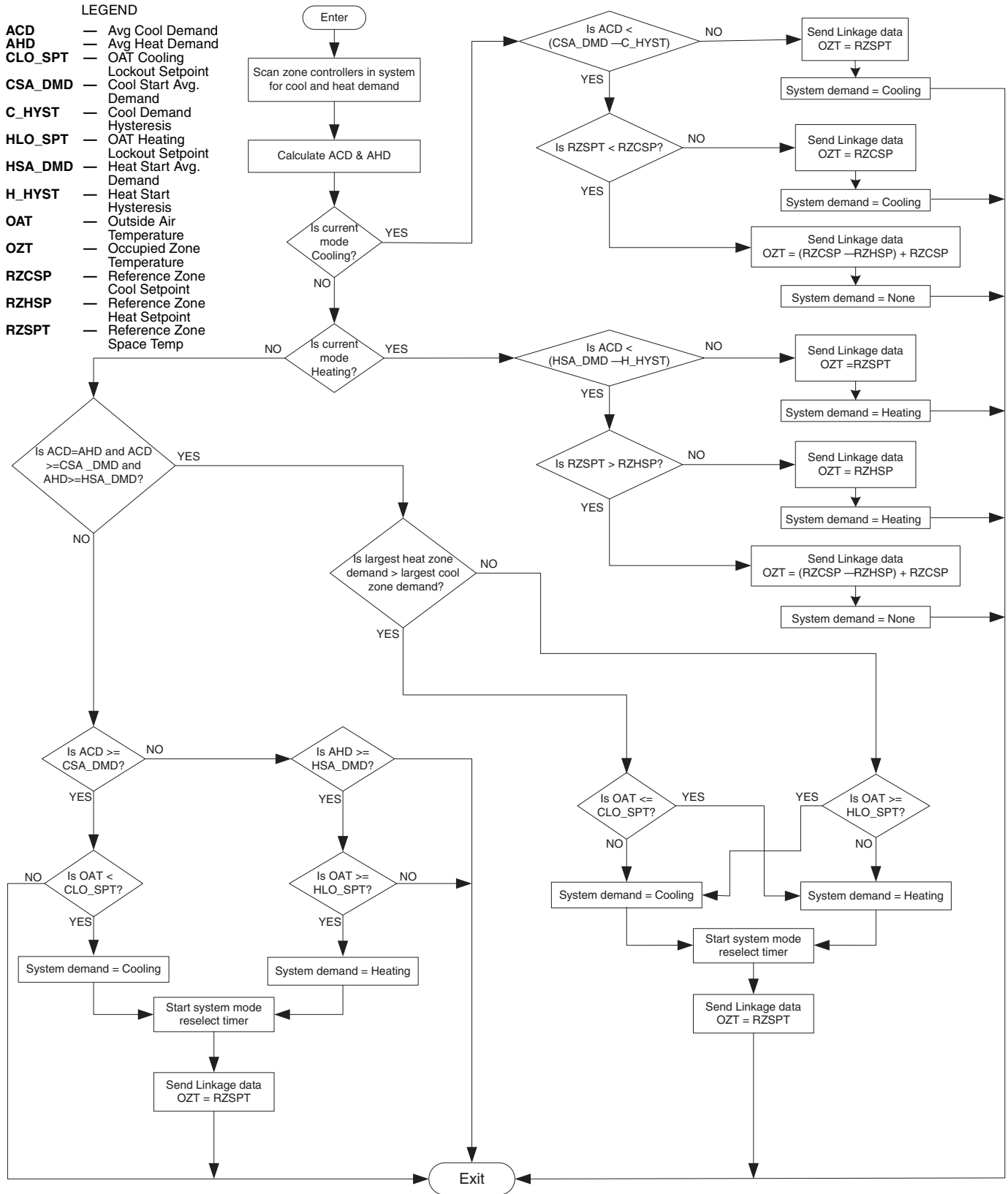

### 3V™ Zone Damper Operation

#### LEGEND

- DMPPOS** — Damper Position
- EVAC** — Evacuation
- HSMR** — Heat Submaster Reference
- PID** — Proportional/Integral/Derivative
- PRES** — Pressurization
- SAT** — Supply Air Temperature
- SPT** — Space Temperature
- TC\_DPOS** — Temperature Control Damper Output
- VENT** — Ventilation

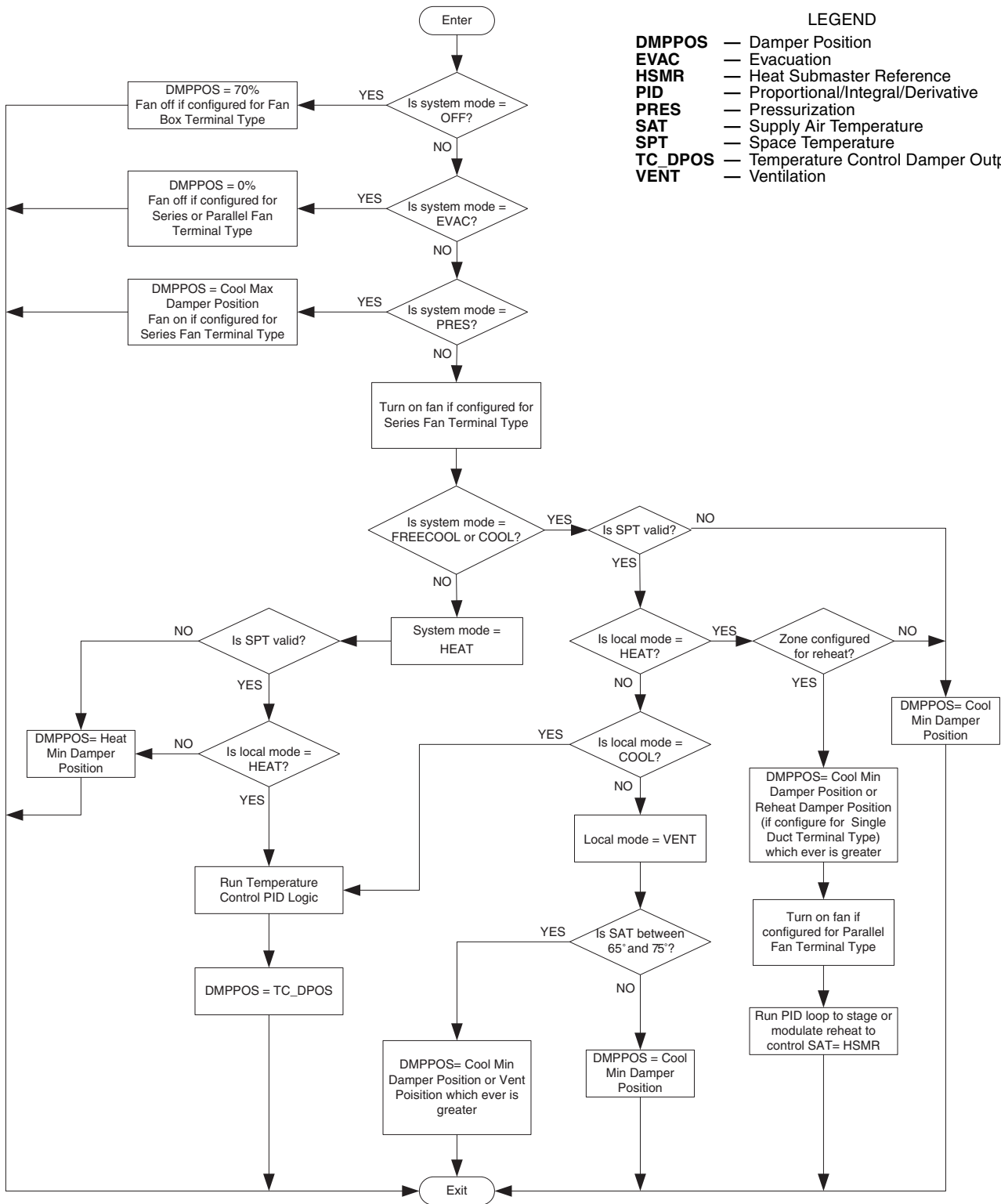



### 3V™ Zone Controller DCV Damper Control Logic

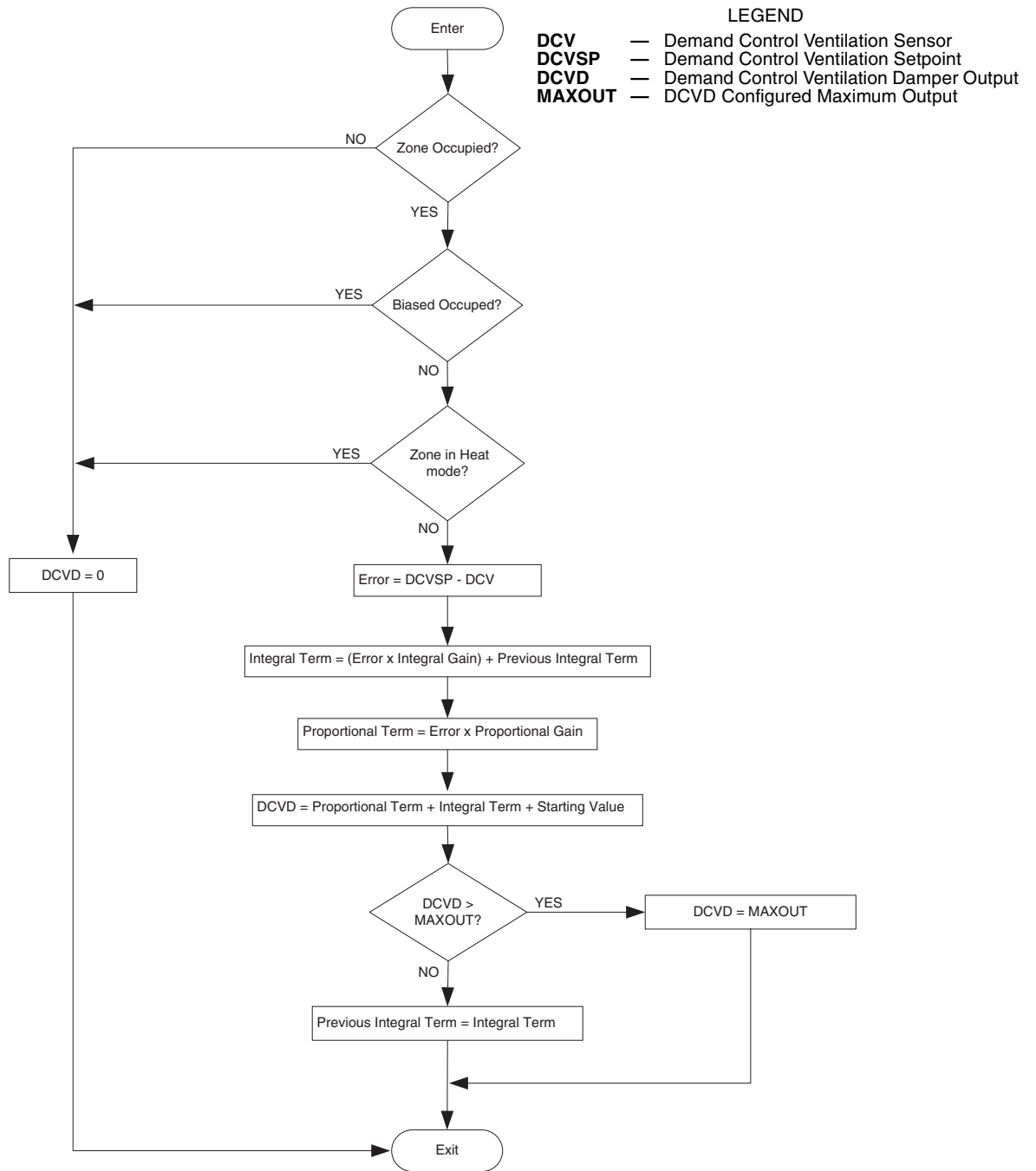

### 3V™ Zone Controller Temperature Control Damper Logic

#### LEGEND

- CCMR — Cooling Setpoint
- DCV — Demand Control Ventilation
- DCVD — DCV Damper Output
- DMD — Zone Demand
- DMPPPOS — Damper Position
- HCMR — Heat Setpoint
- SPT — Space Temperature
- [System Mode] — Current System Mode
- TC\_DPOS — Temperature Control Damper Output

