



United Technologies

## Product Data

AquaEdge® High-Efficiency  
Semi-Hermetic Centrifugal  
Liquid Chillers

500 to 800 Nominal Tons  
(1758 to 2814 Nominal kW)

**AQUAEDGE** greenspeed 



19DV 50/60 Hz  
High-Efficiency Semi-Hermetic Centrifugal Liquid Chillers  
with Greenspeed® Intelligence, PIC 5 Controls, and  
HFO-1233zd(E) Refrigerant

## Features/Benefits

### The 19DV AquaEdge® chiller's use of low GWP (global warming potential) refrigerant 1233zd(E) and its high efficiencies obtained from real world operating conditions greatly diminish the effects of potential direct or indirect global warming.

Carrier's AquaEdge centrifugal chillers offer:

- The use of non-ozone depleting (ODP=0.00) refrigerant HFO-1233zd(E), which is not affected by scheduled US EPA refrigerant phaseouts
- An annual leak rate of 0.1%, one of the lowest published in the industry
- Semi-hermetic compressor
- Variable speed drive
- Modular construction
- Low pressure design
- Two-stage back-to-back EquiDrive™ compressor (500 to 800 tons)
- Refrigerant lubricated bearings
- Hybrid falling-film evaporator
- Variable orifice metering device

The AquaEdge chiller's high efficiencies are obtained in real-world operating conditions. Therefore, the effects of potential direct or indirect global warming are greatly diminished.

#### High efficiency

Today's owners of chilled water plants demand high efficiency from their chillers. As a result, the AquaEdge 19DV centrifugal chiller offers a variable speed, two-stage economized refrigeration cycle, maximizing both full load and part load efficiency.

The AquaEdge 19DV centrifugal chiller is offered as a variable-speed machine with a unit-mounted variable speed drive to maximize part load efficiency.

#### Environmental leadership

Carrier has long been committed to the environment and its sustainability. 19DV AquaEdge chillers provide a high-efficiency and low GWP (~1) long-term solution unaffected by refrigerant phaseouts. Carrier's decision to utilize HFO-1233zd(E), a non-ozone depleting refrigerant with an extremely low global warming potential of approximately one, provides our customers with a safe and environmentally

balanced choice without compromising efficiency.

#### Reliability

The AquaEdge chiller's two-stage low-pressure EquiDrive™ back-to-back compressor, coupled with ASME (American Society of Mechanical Engineers) constructed heat exchangers, ensures high reliability and sustainability. Carrier's semi-hermetic motors operate in a clean, refrigerant-cooled environment. The semi-hermetic design eliminates the potential for shaft seal leaks and refrigerant loss. These are just some of the reasons why the AquaEdge family of chillers has one of the industry's lowest leak rates.

#### Low pressure design

Carrier's low-pressure design is 15% smaller compared to traditional low-pressure designs. The smaller size minimizes the need for valuable mechanical room floor space.

#### The AquaEdge chiller advantage

The tight construction of the 19DV AquaEdge centrifugal chiller and the high efficiency purge ensures that contaminants stay out, refrigerant stays in, and efficiency is maintained throughout the life of the chiller.

#### Modular construction

The evaporator, condenser, economizer, and compressor assemblies are completely bolted together, making the AquaEdge chillers ideally suited for replacement projects where ease of disassembly and reassembly at the job-site are essential.

#### Semi-hermetic compressor features

**Refrigerant lubricated bearings** are integrated into the low speed direct drive motor shaft.

**Motor** is semi-hermetically sealed from the machine room; cooling is accomplished by spraying liquid refrigerant on the motor windings. This highly efficient motor cooling method results in the use of smaller, cooler-running motors than could be realized with air-cooled designs of the same type.

In addition, Carrier's semi-hermetic design eliminates:

- Compressor shaft seals that require maintenance and increase the likelihood of refrigerant leaks
- Shaft alignment problems that occur with open-drive designs during start-up and operation, when equipment temperature variations cause thermal expansion
- High noise levels that are common with air-cooled motors, which radiate noise to the mechanical room and adjacent areas
- Mechanical room cooling requirements associated with air-cooled motors, which dissipate heat to the mechanical room

#### Compressors are 100% run-tested

to ensure proper operation of all compressor systems, including vibration, electrical, and compression.

**Air-cooled totally enclosed non-ventilated (TENV) VFD (variable frequency drive)** is designed to be cooled without drawing equipment room air inside the VFD enclosure, reducing the risk of exposure of electrical components to dirt, dust and moisture. Using air instead of water also eliminates costly maintenance associated

## Table of contents

	Page
Features/Benefits . . . . .	2
Model Number Nomenclature . . . . .	5
Chiller Components . . . . .	6
Physical Data . . . . .	8
Options and Accessories . . . . .	8
Dimensions . . . . .	9
Selection Procedure . . . . .	11
Electrical Data . . . . .	11
Controls . . . . .	12
Typical Piping and Wiring . . . . .	14
Application Data . . . . .	15
Guide Specifications . . . . .	22

with the water cooling pump, heat exchanger and rubber tubing used with water-cooled VFDs.

### Heat exchanger features

**The American Society of Mechanical Engineers (ASME) standard** requires the use of an independent agency to certify the design, manufacture, and testing of all heat exchangers, ensuring the ultimate in heat exchanger safety, reliability, and long life.

### Industry first low-pressure hybrid falling film evaporator

The hybrid falling film evaporator requires less refrigerant, 20% less than a flooded evaporator of similar capacity, to remove heat from the water circuit. Its unique design allows it to wet the tubes more effectively than a flooded evaporator.

**Hybrid falling-film design** maintains high heat transfer coefficients even at part load conditions.

**1-in. tubes (optional)** provide optimized cost and less pressure drop than the standard 3/4-in. tubes.

**Tube expansion** at center support sheets prevents unwanted tube movement and vibration, thereby reducing the possibility of premature tube failure.

**Closely spaced intermediate support sheets** prevent tube sagging and vibration, thereby increasing heat exchanger life.

**Double-grooved tube sheet holes** eliminate the possibility of leaks between the water and refrigerant circuits, increasing product reliability.

**Condenser baffle** prevents direct impingement of high velocity compressor gas onto the condenser tubes. The baffle eliminates the related vibration and wear of the tubes and distributes the refrigerant flow evenly over the length of the vessel for improved efficiency.

**Refrigerant filter drier isolation valves** allow filter drier replacement without pumping down the chiller, which means less service time and less expense.

**Variable orifice (ball float-type)** provides precise refrigerant metering at any load. As a result, optimal refrigerant levels can be maintained in the chiller's condenser and evaporator to achieve the greatest efficiency without unintentional hot gas bypass or stacking in the condenser.

### Microprocessor control features

**Direct digital Product Integrated Control (PIC5)** provides unmatched flexibility and functionality. Each unit integrates directly with the Carrier Comfort Network® (CCN) system, providing a system solution to controls applications. The PIC5 control can be configured to display units in English or metric, and provides unparalleled ease of operation.

The PIC5 display offers an "all-in-one" view of key chiller operational data, simplifying the interaction between the chiller and user.

Features include:

- Display of over 125 operating, status, and diagnostic messages for improved user experience
- Monitoring of over 100 functions and parameters to protect the chiller from abnormal conditions
- Modular pull-out/plug-in design, reducing wiring requirements and providing easy installation
- Low-voltage (24 v) design, providing the ultimate assurance of personal safety and control integrity

The display modes include 8 standard languages:

- English
- Chinese
- Spanish
- French
- German
- Dutch
- Italian
- Portuguese

**Automatic capacity override** function unloads the compressor whenever key safety limits are approached, increasing unit life.

**Chilled water reset** can be accomplished manually or automatically from the building management system. Reset saves energy when warmer chilled water can be used.

**Demand limiting** feature limits the power draw of the chiller during peak loading conditions. When incorporated into the Carrier Comfort Network® building automation system, a red line command holds chillers at their present capacity and prevents any other chillers from starting. If a load shed signal is received, the compressors are unloaded to avoid high demand charges whenever possible.

**Ramp loading** ensures a smooth pull-down of water loop temperature and prevents a rapid increase in compressor power consumption during the pulldown period.

**Automated controls test** can be executed prior to start-up to verify that the entire control system is functioning properly.

**365-day real time clock** feature allows the operator to program a yearly schedule for each week, weekends, and holidays.

**Occupancy schedules** can be programmed into the controller to ensure that the chiller only operates when cooling is required.

**Extensive service menu** features include password protection to prevent unauthorized access to the service menu. Built-in diagnostic capabilities assist in troubleshooting and recommend proper corrective action for preset alarms, resulting in greater operating time.

**Alarm file** maintains the last 25 time and date-stamped alarm and alert messages in memory; this function reduces troubleshooting time and cost.

**Configuration data backup** in non-volatile memory provides protection during power failures and eliminates time-consuming control reconfiguration.



# Features/Benefits (cont)



## 19DV refrigeration cycle

The compressor continuously draws refrigerant vapor from the evaporator at a rate set by the position of the inlet guide vanes and compressor speed. As the compressor suction reduces the pressure in the evaporator, the remaining refrigerant boils at a fairly low temperature (typically 38 to 42°F [3 to 6°C]). The energy required for boiling is obtained from the water flowing through the evaporator tubes. With heat energy removed, the water becomes cold enough to use in an air-conditioning circuit or process liquid cooling.

After taking heat from the water, the refrigerant vapor is compressed.

Compression adds still more heat energy and the refrigerant is quite warm (typically 98 to 102°F [37 to 40°C]) when it is discharged from the compressor into the condenser.

Relatively cool (typically 65 to 90°F [18 to 32°C]) water flowing into the condenser tubes removes heat from the refrigerant, and the vapor condenses to liquid.

The liquid drains into a variable orifice where it meters the liquid refrigerant required to meet the load demand. The variable orifice forms a liquid seal between the condenser and economizer. The liquid refrigerant from the variable orifice flows into the economizer at an

intermediate pressure. In the economizer, vapor is separated from the liquid, flashing and removing heat from the remaining liquid; the separated vapor flows to the second stage of the compressor. Since the economizer gas only passes through half of the compression cycle to reach condenser pressure, power savings are achieved and the refrigeration effect is enhanced. After leaving the economizer, the remaining liquid refrigerant passes through a second variable orifice. The refrigerant is now at the temperature and pressure at which the cycle began. Refrigerant from the condenser also cools and lubricates the drive train components.

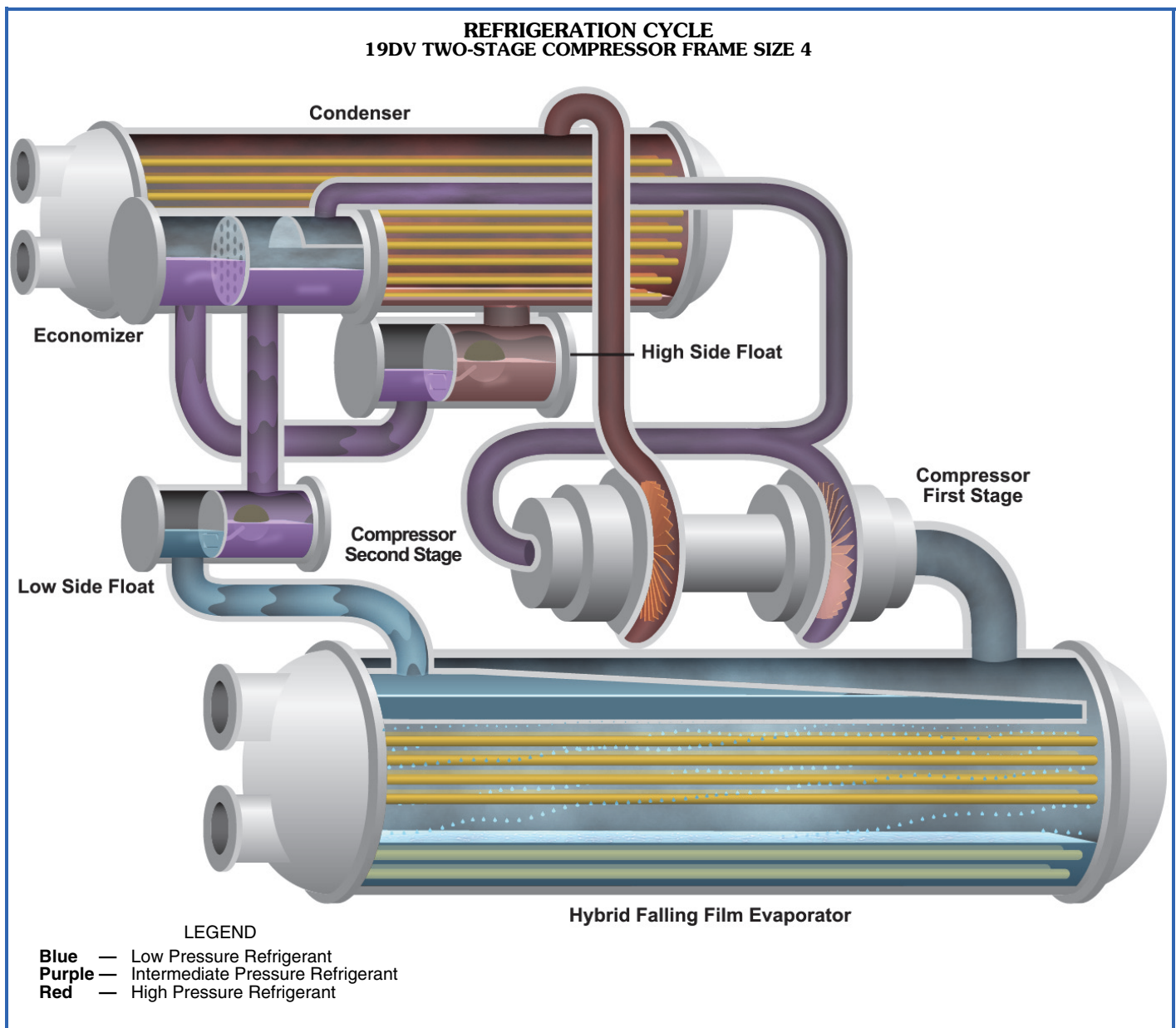



# Model number nomenclature



## 19DV TWO-STAGE COMPRESSOR FRAME SIZE 4

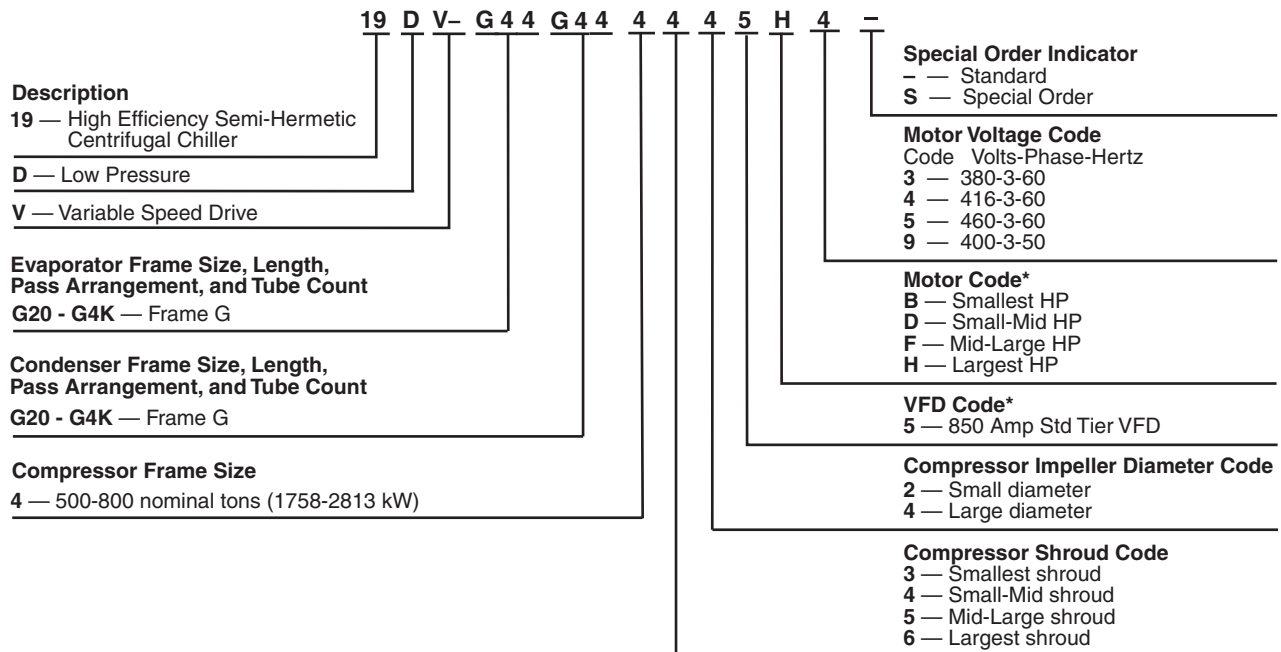

\*Refer to 19DV NG E-Cat Builder for motor and VFD size details.



### Quality Assurance

ISO 9001:2008-certified processes

AHRI (Air-Conditioning, Heating, and Refrigeration Institute) Performance Certified

## COMPRESSOR COMPONENTS 19DV TWO-STAGE COMPRESSOR FRAME

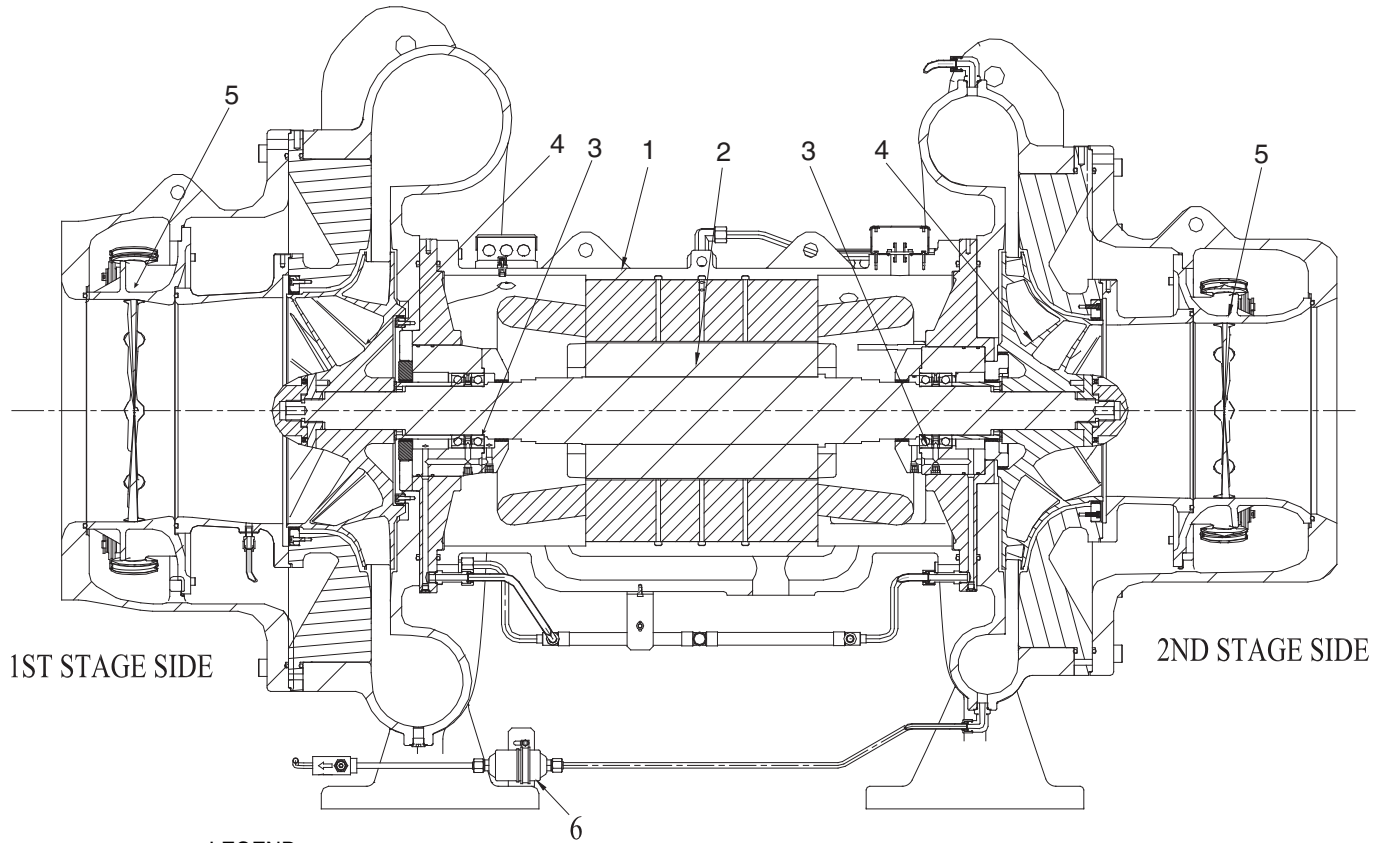

### LEGEND

- 1 — Motor Stator
- 2 — Motor Rotor
- 3 — Ceramic Bearing
- 4 — Impeller
- 5 — Variable Inlet Guide Vanes
- 6 — Filter

FRONT VIEW

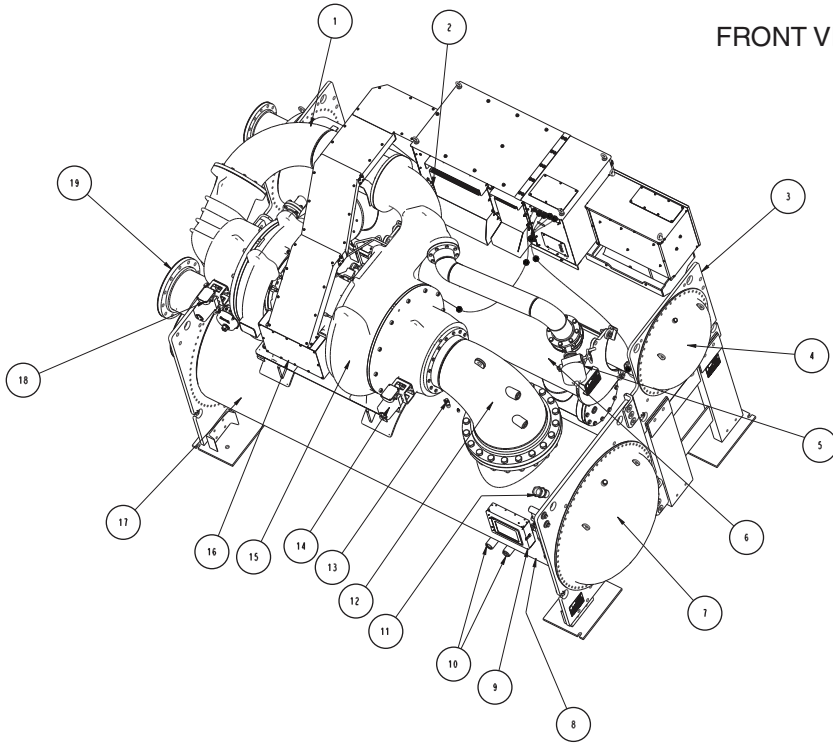

- 1 - INTERCONNECTING COMPRESSOR PIPING
- 2 - VFD DRAIN (FIELD DRAIN PIPING REQUIRED)
- 3 - CONDENSER
- 4 - CONDENSER WATERBOX RETURN END
- 5 - ECONOMIZER ISOLATION VALVE (OPTION)
- 6 - ECONOMIZER
- 7 - EVAPORATOR WATERBOX RETURN END
- 8 - VACUUM/CHARGING VALVE (HIDDEN)
- 9 - PIC 5 HMI TOUCHSCREEN PANEL
- 10 - EVAPORATOR BUNDLE SIGHT GLASSES
- 11 - RUPTURE DISC
- 12 - SUCTION ELBOW
- 13 - EVAPORATOR CHARGING VALVE AND EVAPORATOR PRESSURE TRANSDUCER
- 14 - 1ST STAGE GUIDED VANE ACTUATOR
- 15 - COMPRESSOR MOTOR
- 16 - MOISTURE INDICATOR (HIDDEN)
- 17 - EVAPORATOR
- 18 - 2ND STAGE GUIDED VANE ACTUATOR
- 19 - EVAPORATOR WATERBOX NOZZLES

REAR VIEW

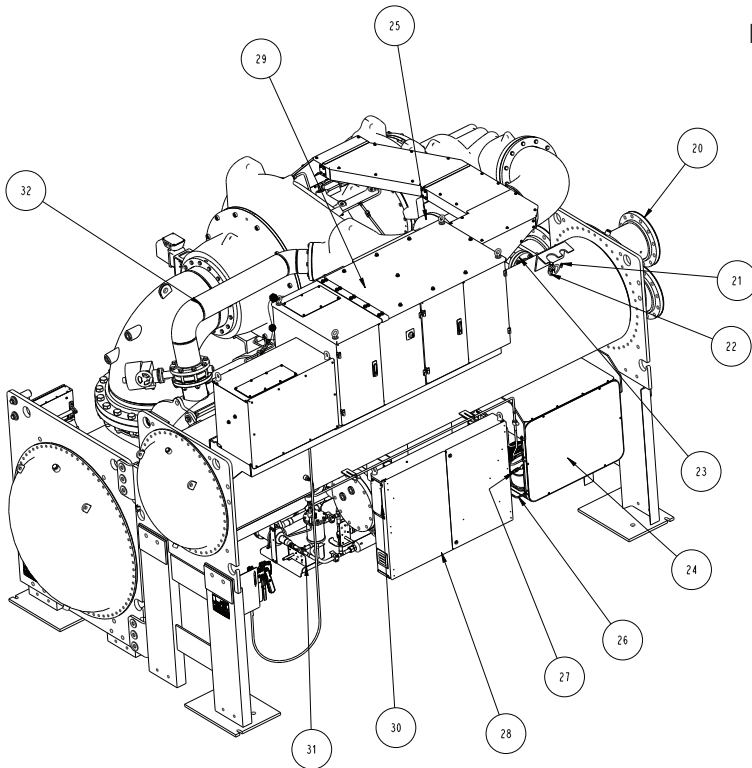

- 20 - CONDENSER WATERBOX NOZZLES
- 21 - CONDENSER PRESSURE TRANSDUCER
- 22 - CONDENSER CHARGING VALVE
- 23 - ENVELOPE STABILITY CONTROL PIPE
- 24 - PURGE ASSEMBLY
- 25 - DISCHARGE PIPE
- 26 - PURGE VENT (HIDDEN)
- 27 - MOTOR VFD COOLING MOISTURE INDICATOR
- 28 - CONTROL PANEL
- 29 - VFD
- 30 - CHILLER NAME PLATE LABEL
- 31 - LUBRICATION ASSEMBLY
- 32 - ECONOMIZER PIPE



# Physical data



**19DV chiller weight** —The weight of a 19DV chiller is best obtained by running the chiller selection software. The 19DV has an extensive number of possible combinations of evaporators (including tubing type and length), condensers (including tubing type and length), waterbox types (taking into account heat exchanger passes), compressors, motors, and system accessories. The 19DV selection software will determine the rigging weight, operating weight,

corner weight, and spring deflection (if applicable) of any configured unit.

Due to rigging and installation considerations, there are times when it becomes necessary to determine the contribution of individual components that comprise the chiller. For these situations, a detailed component breakdown is provided in the 19DV Installation Instructions.

## Options and accessories

ITEM	OPTION (FACTORY INSTALLED)	ACCESSORY (FIELD INSTALLED)
1, 2, or 3 Pass Evaporator or Condenser Water-side Construction	X	
Envelope Stability Control	X	
Thermal Insulation (Except Waterbox Covers)	X	
Marine Waterboxes, 150 psig (1034 kPa)*	X	
Flanged Evaporator and/or Condenser Waterbox Nozzles†	X	
Free Cooling Option	X	
Economizer Bypass Valve	X	
0.025 or 0.028in. (0.635 or 0.711 mm) Internally/Externally Enhanced Copper Tubing — Evaporator	X	
0.025, 0.028 or 0.035 in. (0.635, 0.711 or 0.889 mm) Internally/Externally Enhanced Copper Tubing — Condenser	X	
Customer Factory Performance Testing	X	
Extended Warranty (North America only)	X	
Service Contract	X	
SMART Service Connectivity (North America only)	X	
Soleplate Package		X
Multiple Chiller System Remote Temperature Sensor		X
BACnet** Communication Option (BACnet over IP)	X	
Spring Isolator Kit		X

\* Optional marine waterboxes are available for 19DV. Standard waterboxes for 19DV chillers are nozzle-in-head type, 150 psig (1034 kPa).  
 † Standard waterbox nozzles are Victaulic type. Flanged nozzles are available as an option with either nozzle-in-head type waterboxes or marine waterboxes.  
 \*\* BACnet is a registered trademark of ASHRAE (American Society of Heating, Refrigerating, and Air-Conditioning Engineers). English units of measure only.

NOTE: The BACnet option for 19DV (PIC 5 controls) provides BACnet over IP communication only. This option disables CCN communication and i-Vu® controller considers this option to be a third-party device. For higher levels of integration, contact your local Carrier Controls office.

### UNIT-MOUNTED VFD FEATURES AND OPTIONS\*

ITEM	VFD
Microprocessor Based Overload Trip Protection	S
Main Power Fuse	S: 100kA
Phase Loss/Reversal Imbalance Protection	S
Three Phase Ground Fault Protection†	S
Three-Phase Ammeter	S**
Three-Phase Voltmeter	S**
Three-Phase Over/Under Voltage Protection	S**
Frequency Digital Display	S**
Digital Watt Display	S**
Digital Watt Hour Display	S**
Digital Power Factor Display	S**
Demand Kilowatt Display	S**
Lightning Surge Arrestor (MOV)	S

LEGEND  
**S** — Standard Feature  
**VFD** — Variable Frequency Drive

\* Refer to the NG E-CAT Chiller builder software for all VFD options, as some options may not be available for all VFD models.  
 † Low voltage: phase to phase and phase to ground.  
 \*\* Viewable via the HMI touchscreen panel.

## 19DV DIMENSIONS (Nozzle-in-Head Waterbox)

HEAT EXCHANGER SIZE	PASSES	A (LENGTH, WITH NOZZLE-IN-HEAD WATERBOX)		B (WIDTH)		C (HEIGHT)	
		in.	mm	in.	mm	in.	mm
G2- to G2-	1 pass	187.5	4763	108.4	2753	117.0	2972
	2 pass	180.4	4582				
	3 pass	184.0	4674				
G4- to G4-	1 pass	208.0	5283	99.9	2537	117.0	2972
	2 pass	200.9	5102				
	3 pass	204.5	5194				

\*Assumes both evaporator and condenser nozzles on same end of chiller; Nozzle-in-head waterboxes, 150 psi rated.

**NOTES:**

1. Service access should be provided per American Society of Heating, Refrigerating, and Air-Conditioning Engineers (ASHRAE) 15, latest edition, National Fire Protection Association (NFPA) 70, and local safety code.

2. Overhead clearance for service rigging compressor should be at minimum 3 feet (914 mm) with 5 feet (1524 mm) recommended for easier overhead access.
3. Dimensions are approximate. Certified drawings available upon request.
4. 'A' length dimensions shown are for standard 150 psig (1034 kPa) design and Victaulic connections. The 300 psig (2068 kPa) design and/or flanges will add length. See certified drawings.

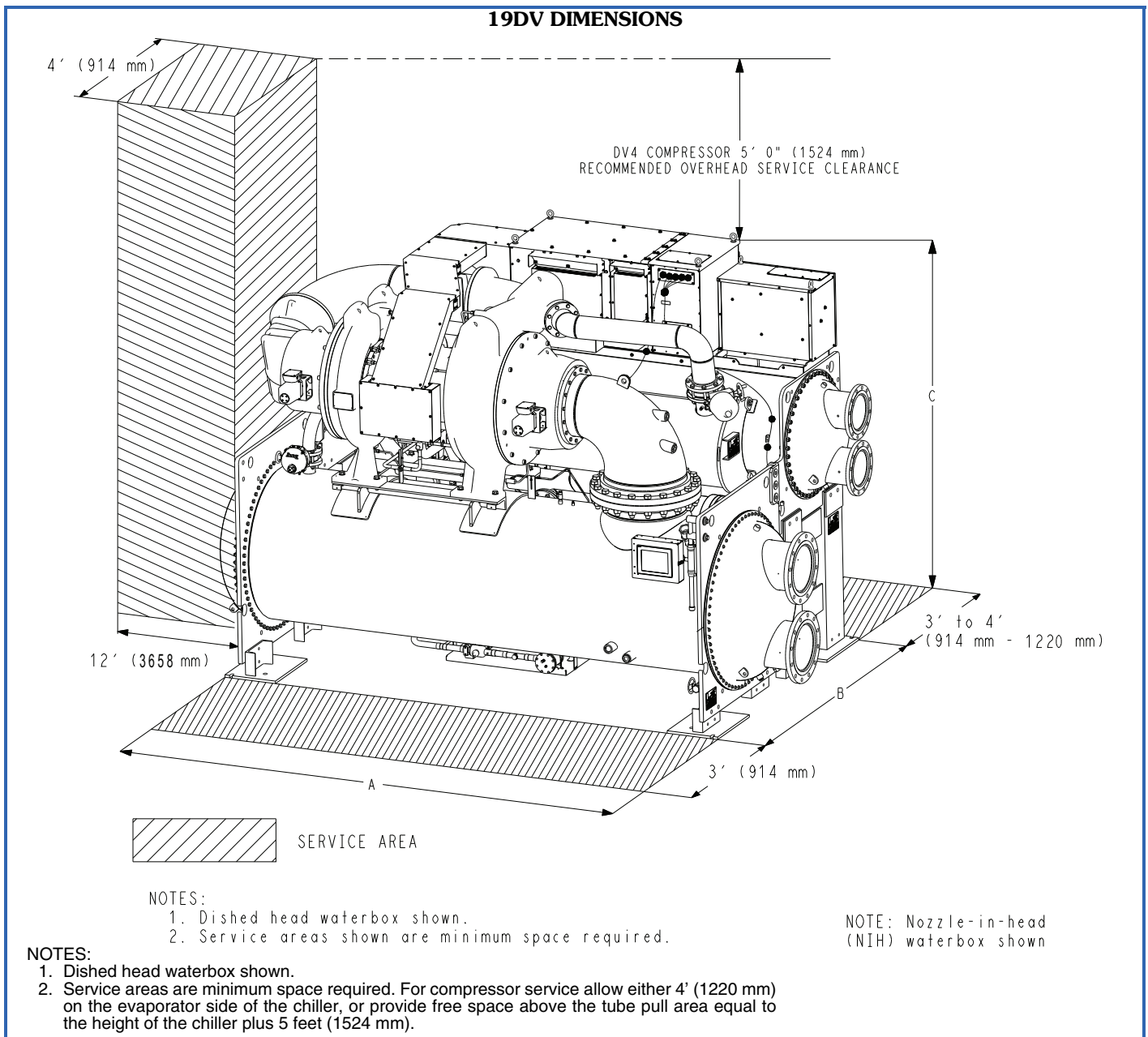

## 19DV DIMENSIONS (MWB Waterbox)

HEAT EXCHANGER SIZE	PASSES	A (LENGTH, WITH MARINE WATERBOX)		B (WIDTH)		C (HEIGHT)	
		in.	mm	in.	mm	in.	mm
G2- to G2-	1 pass	218.5	5550	108.4	2753	117.0	2972
	2 pass	192.3	4883				
	3 pass	210.8	5353				
G4- to G4-	1 pass	239.0	6071	102.2	2594	117.0	2972
	2 pass	212.8	5404	99.9	2537	117.0	2972
	3 pass	231.3	5871				

\*Assumes both evaporator and condenser nozzles on same end of chiller; Nozzle-in-head waterboxes, 150 psi rated.

### NOTES:

1. Service access should be provided per American Society of Heating, Refrigerating, and Air-Conditioning Engineers (ASHRAE) 15, latest edition, National Fire Protection Association (NFPA) 70, and local safety code.

2. Overhead clearance for service rigging compressor should be at minimum 3 feet (914 mm) with 5 feet (1524 mm) recommended for easier overhead access.
3. Dimensions are approximate. Certified drawings available upon request.
4. 'A' length dimensions shown are for standard 150 psig (1034 kPa) design and Victaulic connections. The 300 psig (2068 kPa) design and/or flanges will add length. See certified drawings.

## NOZZLE SIZE

NOZZLE SIZE					
HEAT EXCHANGE FRAME SIZE	TYPE	DESIGN PRESSURE	PASSES	NOZZLE SIZE (IN.) (Nominal Pipe Size)	
				Evaporator	Condenser
G	NIH	150	1	14	12
			2	14	10
			3	12	10
	MWB	150	1	14	12
			2	14	10
			3	12	10



# Selection procedure



The 19DV chiller can be tailored to the specific requirements of a given application. Please contact your local Carrier representative for a selection. The NG E-CAT selection software analyzes many factors, including specific temperature, fluid type, and flow requirements to automatically configure the chiller's heat exchanger size, compressor aerodynamic model, and electrical sizing to deliver a chiller optimized to the job requirements.

## Heat exchangers

### Flow rate

If the evaporator flow is variable, the rate of change of flow should not exceed 50% per minute.

### Water quality

Please consult your local Carrier representative and/or a local water quality expert.

## Electrical data

### AUXILIARY RATINGS (Refrigerant Pump) (3 Phase, 50/60 Hz)

ITEM	AVERAGE kW	MIN/MAX MOTOR VOLTAGE/FREQUENCY V-Ph-Hz	FLA	LRA	SEALED kVA	INRUSH kVA
REFRIGERANT PUMP	0.746	342/418-3-60hz	1.9	14.90	1.25	9.81
	0.746	414/506-3-60hz	1.6	14.87	1.27	11.85
	0.746	342/418-3-50hz	1.8	14.01	1.18	9.22

#### LEGEND

**FLA** — Full Load Amps  
**LRA** — Locked Rotor Amps

NOTE:  $FLA = \text{Sealed kva} \cdot 1000 / \sqrt{3} \cdot \text{volts}$

$LRA = \text{Inrush kva} \cdot 1000 / \sqrt{3} \cdot \text{volts}$

### AUXILIARY RATINGS (Purge Unit)

ITEM	POWER SUPPLY	PANEL kva RATING	AVERAGE WATTS
CONTROLS	24-vac	0.2	200
PURGE UNIT	115/230V	1.5kVA	1500

NOTE: Power to controls must be on circuits that can provide continuous service when the compressor is disconnected.

## Microprocessor controls

The microprocessor control system matches the capacity of the chiller to the cooling load while providing state-of-the-art chiller protection. The microprocessor-based control center protects the chiller by monitoring the digital and analog inputs and executing capacity overrides or safety shutdowns as necessary.

The system controls cooling load within the set point (plus or minus the dead band) by sensing the water or brine temperature and regulating the inlet guide vanes via a mechanically linked actuator motor, and regulating VFD (variable frequency drive) speed.

## Features

### Control system

The control system on each 19DV centrifugal chiller is factory mounted, wired, and tested to ensure machine protection and efficient capacity control. In addition, the program logic ensures proper starting, stopping, and recycling of the chiller and provides a communication link to the Carrier Comfort Network® (CCN) system. The PIC 5 control system consists of one main control board and up to four IOBs (input/output board modules). All boards communicate via an internal LEN bus. The main control board is supplied from a 24 VAC supply reference to earth ground. In the event of a power supply interrupt, the unit can restart automatically without the need for an external command. However, any faults active when the supply is interrupted are saved, and may in certain cases prevent a circuit or unit from restarting. IOBs are supplied from a 24 VAC supply reference to earth ground. Always separate communication cables from other cables and always run wiring as directly as possible.

### Sensors

**Pressure transducers** — Pressure transducers measure and control the pressures in the unit. These electronic sensors deliver 0 to 5 VDC. The transducers can be calibrated through the controller. The pressure transducers are connected to the IOBs. See the Pressure Transducers table.

**PRESSURE TRANSDUCERS**

PRESSURE TRANSDUCER	PURPOSE
Evaporator	Measures evaporator pressure
Condenser	Measures condenser pressure
Refrigerant Pump Inlet Pressure Transducer	This transducer measures the pressure of the pump inlet.
Refrigerant Pump Outlet Pressure Transducer	This transducer measures the pressure of the pump outlet.
Bearing Inlet Pressure Transducer	This transducer measures the pressure of the bearing inlet.
Bearing Outlet Pressure Transducer	This transducer measures the pressure of the bearing outlet.

**Temperature sensors** — The system uses electronic sensors to measure and control the temperatures in the unit. There are three types of temperature sensors: 5K thermistor, 10K thermistor, and RTD (resistance temperature detector), 100 ohm, 3-wire based on IOB channel configurations. The temperature sensor range is -40°F (-40°C) to 245°F (118°C). See the Temperature Sensors table.

**TEMPERATURE SENSORS**

TEMPERATURE SENSOR	PURPOSE
Entering Chilled Water	Measures entering evaporator water temperature
Leaving Chilled Water	Measures leaving evaporator water temperature
Entering Condenser Water	Measures entering condenser water temperature
Leaving Condenser Water	Measures leaving condenser water temperature
Evaporator Refrigerant Liquid	Measures evaporator refrigerant liquid temperature
Compressor Discharge	Measures compressor discharge temperature
First Stage Bearing Temp Sensor	Measures the first stage bearing temperature
Second Stage Bearing Temp Sensor	Measures the second stage bearing temperature
Bearing Refrigerant Supply Temp Sensor	Measures the bearing refrigerant supply temperature
Motor Winding Temperature Sensors	The sensors measure the temperature of compressor motor windings

## Controls Outputs

**Evaporator/condenser water pump** — The controller can stop and start an evaporator/condenser water pump.

**Inlet guide vanes** — The inlet guide vanes adjust the refrigerant vapor flow into the compressors to adapt to change in the operating conditions of the machine. To adjust the refrigerant flow, the guide vanes open or close to vary the cross-section of the refrigerant path. The high degree of accuracy with which the guide vanes are positioned ensures that the flow of refrigerant is precisely controlled.

**Envelope stability control valve** — The envelope stability control valve is a modulating valve that positions as part of the chillers control algorithm to ensure smooth, proper operation as the chiller unloads across its operating profile.

**VFD** — The VFD modifies motor voltage input and frequency to allow the chiller to react to changing lift conditions. Additionally, it allows compressor start-up and, along with inlet guide vanes, provides capacity control.

### Safety cutouts

- Low bearing pressure differential
- Guide vane calibration not completed
- Guide vane fault
- High bearing temperature

- High motor temperature
- High discharge temperature
- Low refrigerant temperature
- High evaporator pressure
- Under voltage
- Over voltage
- Intermittent power loss
- VFD configuration conflict
- High pressure switch
- Low liquid level in high-side float valve chamber
- Low bearing refrigerant supply sub cooling
- Compressor starter faults
- Compressor surge protection
- Cooler freeze protection
- Ground fault

### User interface

The PIC 5 Human Machine Interface (HMI) is a color 10.4-in. TFT touch screen. Navigation is either direct from the touch screen interface or by connecting to a web interface at the Ethernet IP port of the controller. The navigation menus are the same for both connection methods.

**Web connection** — Two web connections may be authorized at the same time. When two users are connected simultaneously, there is no priority between users; that is, the last modification is in effect regardless of the user.

Connection is from a personal computer using a Java-enabled web browser. The minimum browser configuration includes:

- Microsoft Internet Explorer (version 8 or higher) or Mozilla Firefox (version 3.5.2 or higher). In the advanced connection options, add the unit address to the address list. Do not use a proxy server.
- Java platform (version 6 or higher). In the control panel, deselect (uncheck) the option that allows storing temporary Internet files and use a direct connection.
- Enabling/disabling HTTP service requires manual access to controller. Power cycle of controller is not needed.
- The HTTP service will automatically disable after a Timeout time (configurable, default to 10 minutes, for example). This is to make sure the HTTP service is fully disabled after re-enabled in the job site.

To access the PIC 5 user interface, enter the IP address of the unit in the address bar of the web browser. The IP address can be viewed or changed from the PIC 5 interface.



## 19DV CHILLER WITH UNIT-MOUNTED VFD

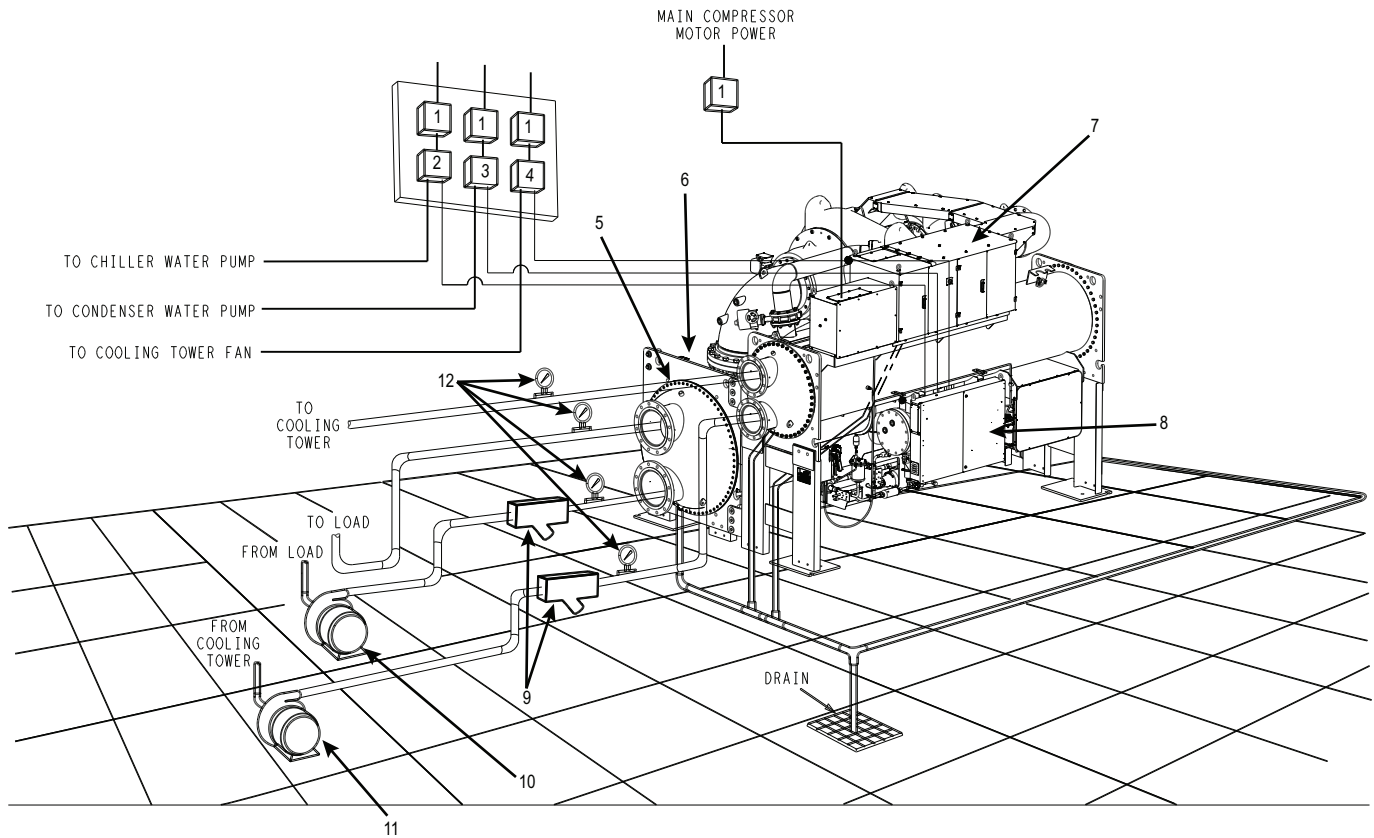

### LEGEND

- 1 — Disconnect
  - 2 — Chilled Water Pump Starter
  - 3 — Condenser Water Pump Starter
  - 4 — Cooling Tower Fan Starter (Low Fan, High Fan)
  - 5 — Vents
  - 6 — HMI (hidden)
  - 7 — Unit-Mounted VFD
  - 8 — Control Panel
  - 9 — Strainers
  - 10 — Chilled Water Pump
  - 11 — Condenser Water Pump
  - 12 — Pressure Gages
- Piping  
 Control Wiring  
 Power Wiring

### NOTES:

1. Wiring and piping shown are for general point-of-connection only and are not intended to show details for a specific installation. Certified field wiring and dimensional diagrams are available on request.
2. All wiring must comply with applicable codes.
3. Wiring not shown for optional devices such as:
  - Remote Start/Stop
  - Remote Alarms
  - Optional Safety Device
  - 4 to 20 mA Resets
  - Optional Remote Sensors
4. **IMPORTANT:** Carrier suggests that a structural engineer be consulted if transmission of vibrations from mechanical equipment is of concern.
5. Isolation valves are recommended on the evaporator and condenser piping to each chiller for service.
6. Operating environment — Chiller should be installed in an indoor environment where the ambient temperature is 40 to 104°F (4 to 40°C) with a relative humidity (non-condensing) of 95% or less.

## 19DV TWO-STAGE COMPRESSOR MACHINE FOOTPRINT

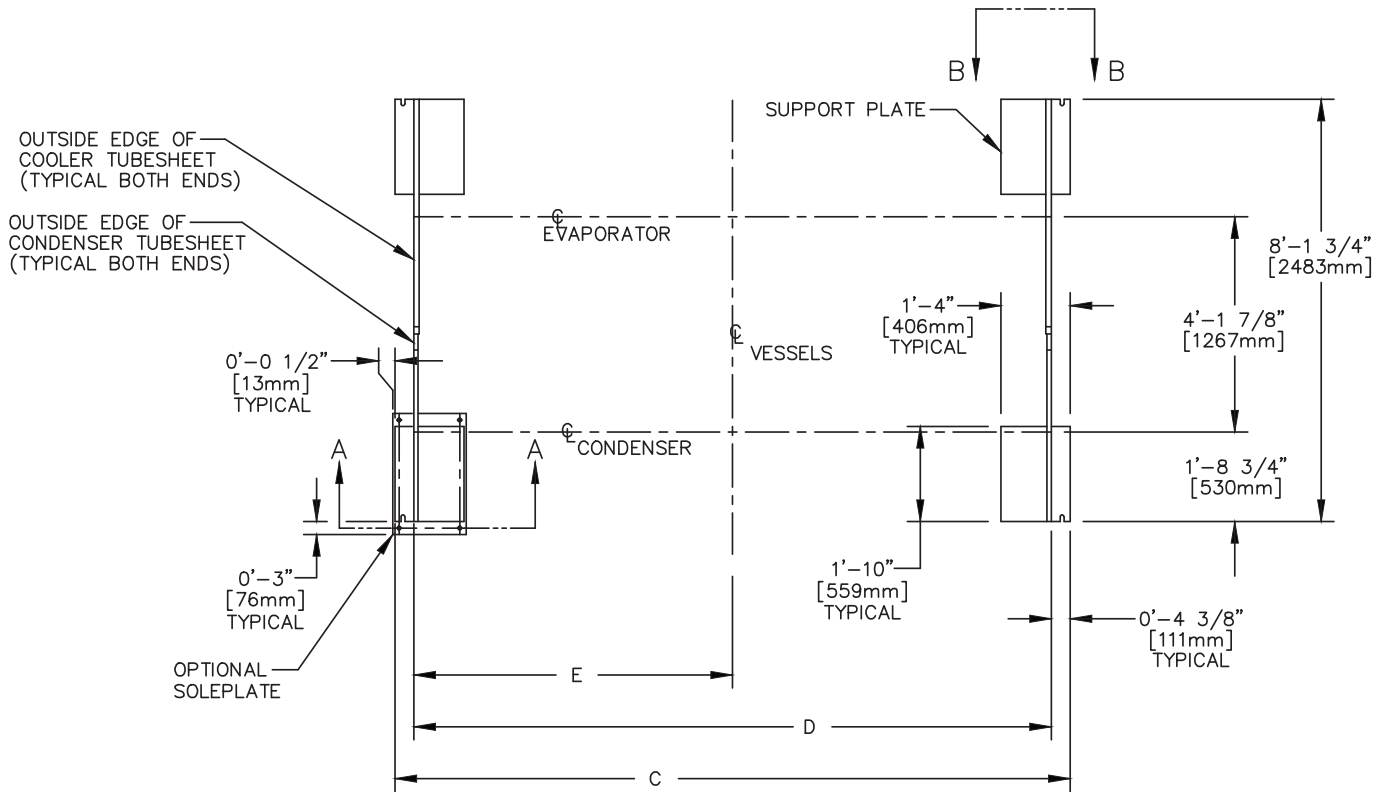

19DV HEAT EXCHANGER SIZE	19DV HEAT EXCHANGER SIZE	
	ft-in.	mm
G2*-G2*	13'-0 1/4"	3969
G4*-G4*	14'-8 3/4"	4490

DIMENSION C		DIMENSION D		DIMENSION E	
ft-in.	mm	ft-in.	mm	ft-in.	mm
13'-0 1/4"	3969	12'-3 1/2"	3747	6'-1 3/4"	1873
14'-8 3/4"	4490	14	4267	7'-0"	2134

**NOTES:**

1. A-A dimension refers to accessory soleplate. See page 16.
2. B-B dimension refers to standard support plate. See page 16.

## 19DV ISOLATION WITH ACCESSORY SOLEPLATE PACKAGE

### TYPICAL ISOLATION

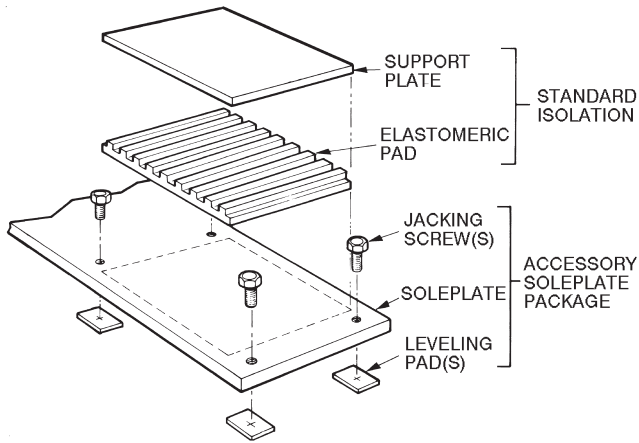

### STANDARD ISOLATION

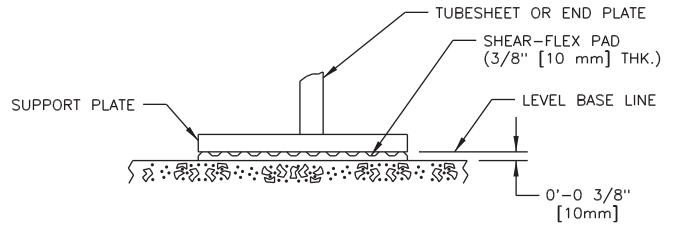

VIEW B-B

### ISOLATION WITH STANDARD PACKAGE ONLY

NOTE: Isolation package includes 4 Shear-Flex isolation pads.

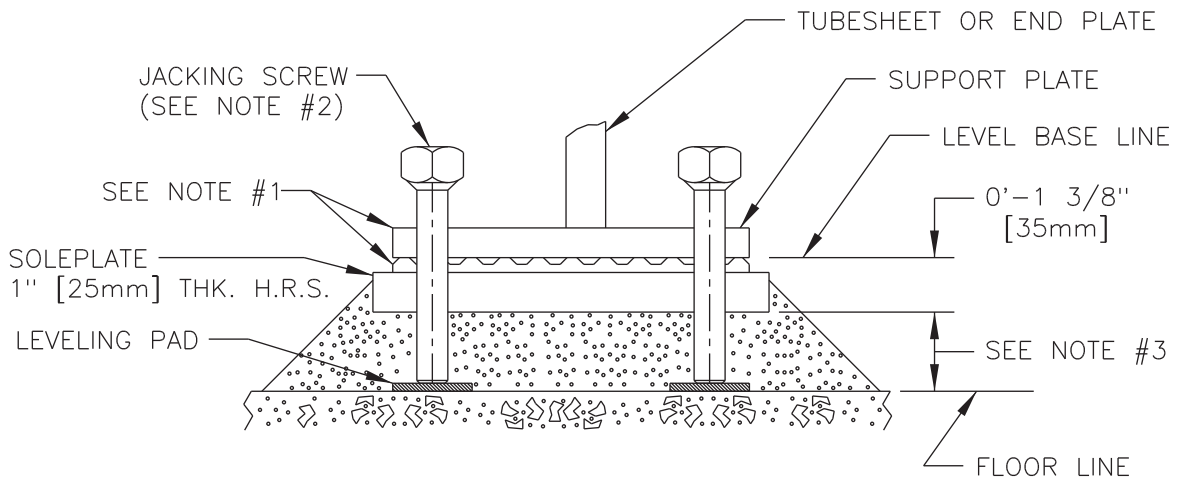

VIEW A-A

#### NOTES:

1. Optional soleplate package includes 4 soleplates, 16 jacking screws and 16 leveling pads. Isolation package is also required.
2. Jacking screws to be removed after grout has set.
3. Thickness of grout will vary, depending on the amount necessary to level chiller. Use only pre-mixed non-shrinking grout, Ceilcote 748 OR Embecco 636 Plus, 0'-1 1/2" (38.1 mm) to 0'-2 1/4" (57 mm) thick.

### 19DV NOZZLE ARRANGEMENTS NOZZLE-IN-HEAD WATERBOXES

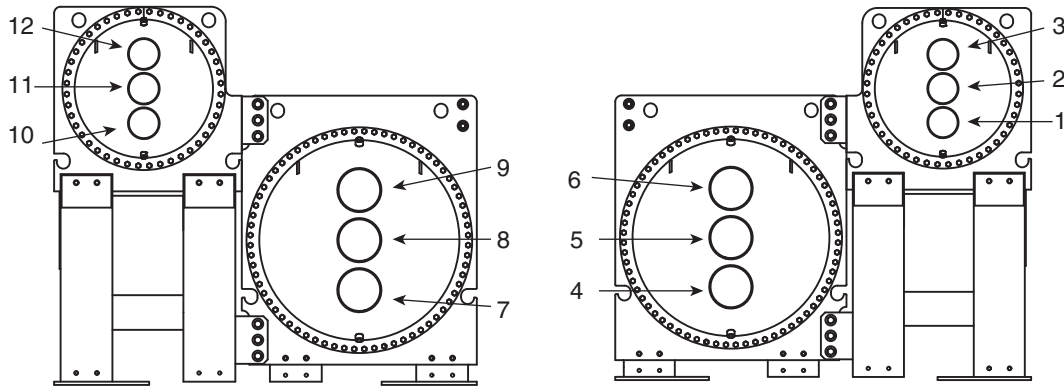

**NOZZLE ARRANGEMENT CODES FOR 19DV NOZZLE-IN-HEAD WATERBOXES**

PASS	EVAPORATOR WATERBOXES		
	In	Out	Arrangement Code*
1	8	5	A
	5	8	B
2	7	9	C
	4	6	D
3	7	6	E
	4	9	F

PASS	CONDENSER WATERBOXES		
	In	Out	Arrangement Code*
1	11	2	P
	2	11	Q
2	10	12	R
	1	3	S
3	10	3	T
	1	12	U

\*Refer to certified drawings.  
NOTE: Vents and drains are 3/4" FPT condenser and 1" FPT evaporator, located on the waterbox head.

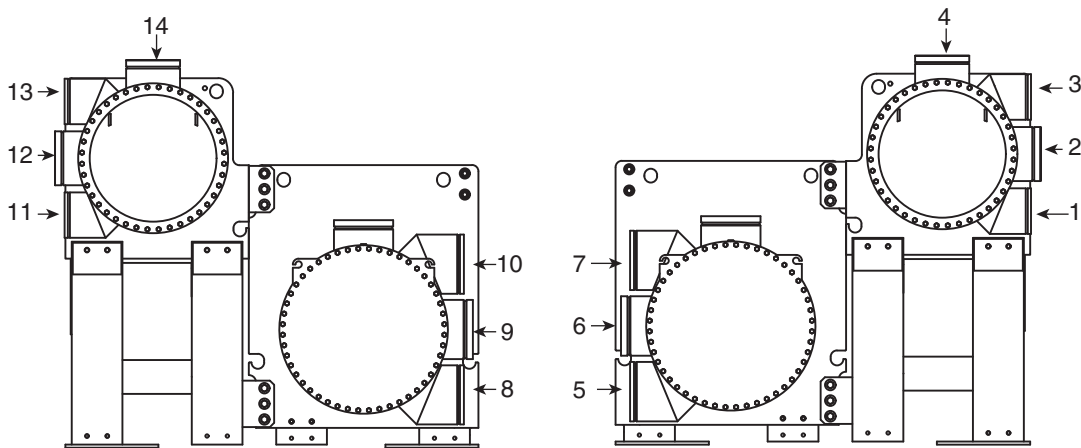

**NOZZLE ARRANGEMENT CODES FOR 19DV MARINE WATERBOXES**

PASS	EVAPORATOR WATERBOXES		
	In	Out	Arrangement Code*
1	9	6	A
	6	9	B
2	8	10	C
	5	7	D
2 alt	N/A	N/A	N/A
	N/A	N/A	N/A
3	8	7	E
	5	10	F

PASS	CONDENSER WATERBOXES		
	In	Out	Arrangement Code*
1	12	2	P
	2	12	Q
2	11	13	R
	1	3	S
2 alt	11	14	V
	1	4	W
3	11	3	T
	1	13	U

\*Refer to certified drawings.  
NOTE: Vents and drains are 3/4" FPT condenser and 1" FPT evaporator, located on the waterbox cover or shell.



## RUPTURE DISC LOCATION

LOCATION	HEAT EXCHANGER FRAME SIZE	EVAPORATOR CONNECTION SIZE
		FEMALE NPT
Evaporator (Protects evaporator, condenser, high float chamber, low float chamber, economizer)	G20-G29	2"
	G40-G49	2"
	G2A-G2K	2"
	G4A-G4K	2"

**NOTES:**

1. The rupture disc is only set on the evaporator, and provides shared protection area with all of other pressure components.
2. Field Connection size is shown.

## 19DV RUPTURE DISC DISCHARGE PIPE SIZING

HEAT EXCHANGER	FRAME SIZE	UNIT'S REQUIRED C FACTOR (LB AIR/MIN)	RUPTURE DISC RATED C FACTOR (LB AIR/MIN)	FIELD CONNECTION SIZE (FNPT)
Evaporator, Condenser, Economizer, and High Side Float Chamber	G20-G29	158	208	2
	G2A-G2K	158	208	2
	G40-G49	180	208	2
	G4A-G4K	180	208	2

## RUPTURE DISC ARRANGEMENT

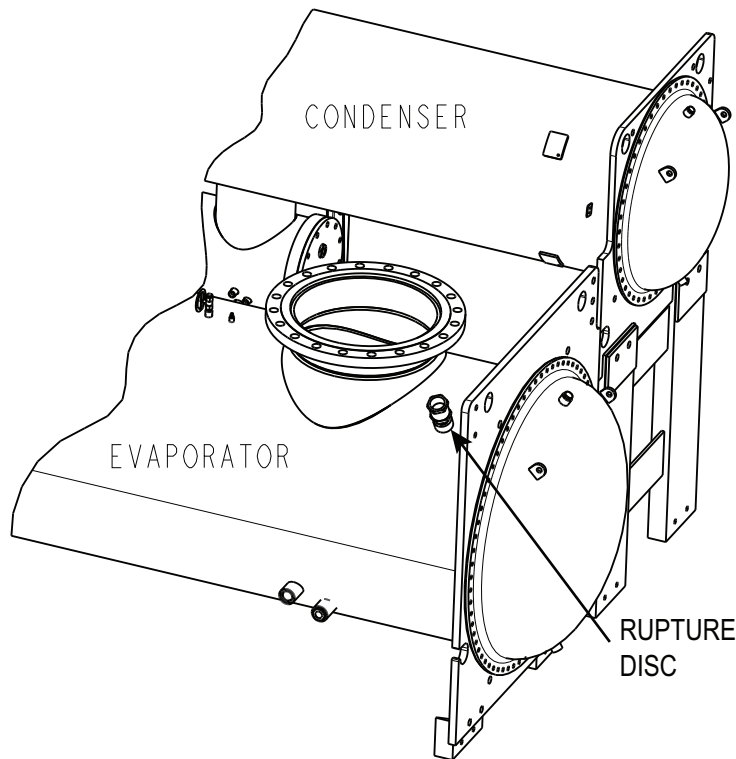

## Vent and drain connections

Nozzle-in-head waterboxes have vent and drain connections on covers. Marine waterboxes have vent and drain connections on waterbox shells.

Provide high points of the chiller piping system with vents and the low points with drains. If shutoff valves are provided in the main water pipes near the unit, a minimal amount of system water is lost when the heat exchangers are drained. This reduces the time required for drainage and saves on the cost of re-treating the system water.

It is recommended that pressure gages be provided at points of entering and leaving water to measure pressure drop through the heat exchanger. Gages may be installed as shown in Pressure Gage Location table. Pressure gages installed at the vent and drain connections do not include nozzle pressure losses.

Use a reliable differential pressure gage to measure pressure differential when determining water flow. Regular gages of the required pressure range do not have the accuracy to provide accurate measurement of flow conditions.

### PRESSURE GAGE LOCATION

NUMBER OF PASSES	GAGE LOCATION (Evaporator or Condenser)
1 or 3	One gage in each waterbox
2	Two gages in waterbox with nozzles

## ASME stamping

All 19DV heat exchangers are constructed in accordance with ASHRAE (American Society of Heating, Refrigerating, and Air-Conditioning Engineers) 15 Safety Code for Mechanical Refrigeration (latest edition). This code, in turn, requires conformance with ASME (American Society of Mechanical Engineers) Code for Unfired Pressure Vessels wherever applicable.

Each vessel is constructed and certified in accordance with ASME Section 8, Division 1.

## Rupture disc discharge pipe sizing

See page 18 for number of rupture discs and locations.

Rupture disc discharge piping size should be calculated per ASHRAE 15, latest edition, code using the tabulated C factors for each vessel shown in the table below.

Carrier further recommends that an oxygen sensor be installed to protect personnel. Sensor should be able to sense the depletion or displacement of oxygen in the machine room below 19.5% volume oxygen per ASHRAE 15, latest edition.

## Design pressures

Design and test pressures for heat exchangers are listed below.

### DESIGN AND MINIMUM TEST PRESSURES

VESSEL	PRESSURES	SHELL SIDE (Refrigerant)		STANDARD TUBE SIDE (Water)		OPTIONAL TUBE SIDE (Water)	
		psig	kPa	psig	kPa	psig	kPa
Chiller including evaporator, condenser, and economizer	Design	57.00	393	150	1034	300	2068
	Burst Test (Refrigerant Side)	62.70	432	—	—	—	—
	Leak Test (Refrigerant Side)	57.00	393	—	—	—	—
	Hydro Test (Refrigerant Side)	—	—	—	—	—	—
	Hydro Test (Water Side)	—	—	195	1344	390	2690

### HEAT EXCHANGER MATERIAL SPECIFICATIONS

ITEM	MATERIAL	SPECIFICATION
Shell	Carbon Steel	ASME SA-516 Gr 70
Tube Sheet	Carbon Steel	ASME SA-516 Gr 70
Flat Covers	Carbon Steel	ASTM A 516 Gr 70
Pipe	Welded Black Steel Pipe or Seamless Carbon Steel Pipe or Carbon Steel Forgings	ASME B16.9 or SA-53 E/B or SA-106 Gr B or SA-105
Flanges	Carbon Steel Forgings or Hot Rolled	ASME SA-105 Forge or SA-181 Gr 70 Forge or SA-516 Gr 70 HR
Condenser Float Box Shell	Welded Black Steel Pipe or Seamless Carbon Steel Pipe	ASME SA-53 E/B or SA-106 Gr B
Tubes	Seamless Copper Tube	ASME SB-75
Dished Cover	Carbon Steel	ASME SA-516 Gr 70
Marine Water Box Shell	Carbon Steel	ASTM A 516 Gr 70 or A 36

## ECONOMIZER MATERIAL SPECIFICATIONS

ITEM	MATERIAL	SPECIFICATION
Shell	Welded Black Steel Pipe or Seamless Carbon Steel Pipe	ASME SA-53 E/B or SA-106 Gr B
Cover	Carbon Steel	ASME SA-516 Gr 70
Pipe	Welded Black Steel Pipe or Seamless Carbon Steel Pipe	ASME SA-53 E/B or SA-106 Gr B

### LEGEND

**ASME** — American Society of Mechanical Engineers  
**ASTM** — American Society for Testing and Materials  
**HR** — Hot Rolled

## Insulation

**Factory insulation** — The factory insulation option for the 19DV chillers include the following areas: evaporator (not including waterbox); suction line up to the compressor suction housing; compressor motor and motor cooling return lines; several small cooling system lines; the liquid line; the float chamber; and VFD refrigerant supply and drain lines. Factory insulation also includes economizer and economizer piping. Insulation applied at the factory is  $\frac{3}{4}$  in. (19 mm) thick and has a thermal conductivity K value of 0.28 (Btu in.)/hr ft<sup>2</sup> °F [(0.0404 • W)/(m • °C)]. Insulation conforms with Underwriters Laboratories (UL) Standard 94, Classification 94HBF.

### MINIMUM FIELD-INSTALLED INSULATION REQUIREMENTS

CHILLER	HEAT EXCHANGER SIZE	INSULATION	
		ft <sup>2</sup>	m <sup>2</sup>
19DV	G20-G29, G2A-G2K	300	28
	G40-G49, G4A-G4K	350	33

NOTE: Insulation amount includes only the amount of insulation required to insulate the sections of the chiller that would be included in the factory-installed insulation option.

**Insulation at jobsite** — As indicated in the Condensation vs Relative Humidity table, the factory insulation provides excellent protection against condensation under most operating conditions. If temperatures in the equipment

area exceed the maximum design conditions, extra insulation is recommended.

If the machine is to be field insulated, obtain the approximate areas from the Minimum Field-Installed Insulation Requirements table.

Insulation of waterboxes is made only in the field and this area is not included in Minimum Field-Installed Insulation Requirements table. When insulating the covers, allow for service access and removal of covers. To estimate water-box cover areas refer to certified drawings.

High humidity jobsite locations may require field supplied and installed insulation on the float chamber, suction housing, and the lower half of the condenser.

### CONDENSATION VS RELATIVE HUMIDITY\*

AMOUNT OF CONDENSATION	ROOM DRY-BULB TEMP		
	80°F (27°C)	90°F (32°C)	100°F (38°C)
	% Relative Humidity		
None	80	76	70
Slight	87	84	77
Extensive	94	91	84

\*These approximate figures are based on 35°F (1.7°C) saturated suction temperature. A 2° F (1.1°C) change in saturated suction temperature changes the relative humidity values by 1% in the same direction.

**Unit location** — Chiller should be installed in an indoor environment where the ambient temperature is 40 to 104°F (4 to 40°C) with a relative humidity (non-condensing) of 95% or less. To ensure that electrical components operate properly, do not locate the chiller in an area exposed to dust, dirt, corrosive fumes, or excessive heat and humidity.

**19DV FACTORY-INSTALLED INSULATION AREA  
TWO-STAGE CHILLER**

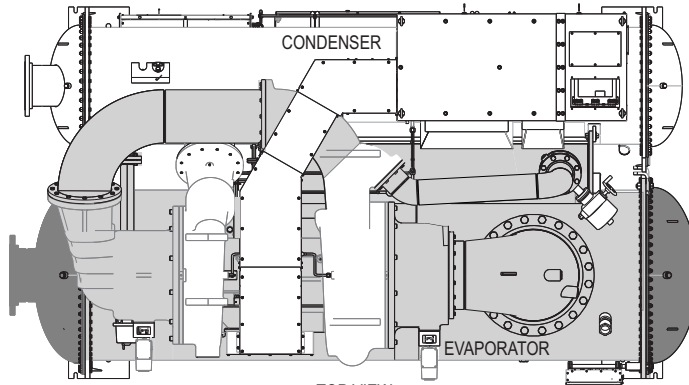

TOP VIEW

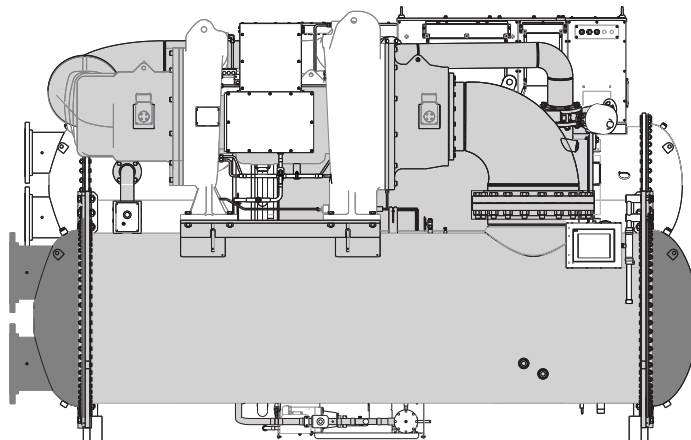

2ND STAGE END

FRONT VIEW

1ST STAGE END

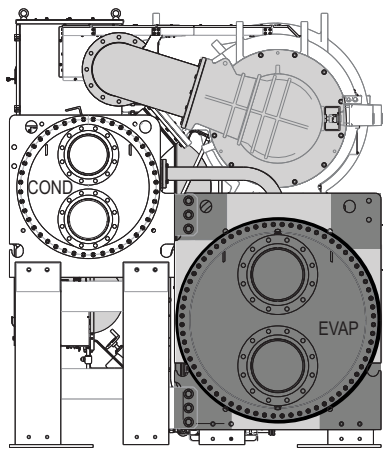

2ND STAGE END VIEW

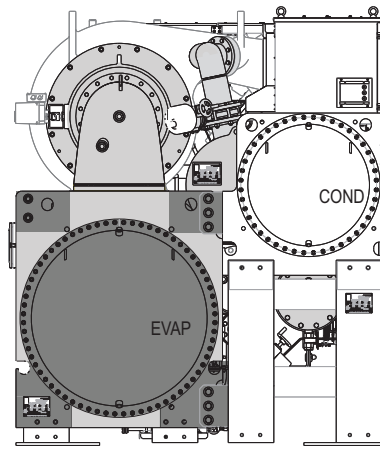

1ST STAGE END VIEW

 FACTORY INSTALLED INSULATION

 FIELD SUPPLIED AND INSTALLED INSULATION (IF REQUIRED)

## Packaged Semi-Hermetic Centrifugal Liquid Chiller

### HVAC Guide Specifications — 19DV

Size Range:

**19DV — 500 to 800 Tons (1758 to 2813 kW)  
Nominal**

Carrier Model Number:

**19DV**

#### Part 1 — General

##### 1.01 SYSTEM DESCRIPTION

- A. Microprocessor-controlled water-cooled chillers shall be factory assembled, single piece, including a single or multi-stage compressor, motor, evaporator, condenser, controls, and variable speed drive. The compressor motor VFD will be mounted on the chiller, wired, and tested by the chiller manufacturer.
- B. The following low GWP refrigerant is considered acceptable:  
HFO-1233zd(E), low pressure, GWP = 1.0
  - 1. Manufacturers shall supply equipment with low GWP HFO refrigerants.
  - 2. If a B1 refrigerant is being offered, a vapor activated alarm system shall be included and be capable of responding to levels of 50 ppm (HFO-514A) Allowable Exposure Limit (AEL). Plant room ventilation required.

##### 1.02 QUALITY ASSURANCE

- A. Chiller's performance shall be rated in accordance with AHRI (Air-Conditioning, Heating and Refrigeration Institute) Standard 550/590 and 551/591, latest edition. The low GWP refrigerants utilized shall be indicated on the AHRI output report and the chiller manufacturer, model number and refrigerant shall be listed on the AHRI.org website ([www.ahridirectory.org](http://www.ahridirectory.org)).
- B. Equipment and installation shall be in compliance with ANSI/ASHRAE (American National Standards Institute/American Society of Heating, Refrigerating and Air-Conditioning Engineers) 15 (latest edition).
- C. Evaporator and condenser refrigerant side shall include ASME "U" stamp and nameplate certifying compliance with ASME Section VIII, Division 1 code for unfired pressure vessels.

The manufacturer shall confirm that the appropriate ASME calculations were performed to the highest leaving condenser water (hot water) temperature listed on the schedule. To be acceptable the highest leaving condenser water temperature shall not be lower than 110°F (43.3°C). If the leaving condenser water temperature is greater than 110°F (43.3°C), the manufacturer shall provide a copy of the ASME calculations proving suitability at that temperature on the submittal.

- D. Chiller shall be designed and constructed to meet UL (Underwriters Laboratories) and CSA (Canadian Standards Association) requirements and have labels appropriately affixed.
- E. Centrifugal compressor impellers shall be dynamically balanced and over-speed tested by the manufacturer at a minimum of 120% design operating speed. Each compressor assembly shall undergo a mechanical run-in test to verify vibration levels, lubricant pressures (if applicable), and temperatures are within acceptable limits.
- F. Each compressor assembly shall be proof tested at a minimum 62.7 psig (432.3 kPa) and leak tested at 57 psig (393 kPa) with a tracer gas mixture.
- G. Entire chiller assembly shall be proof tested at 62.7 psig (432.3 kPa) and leak tested at 57 psig (393 kPa) with a tracer gas mixture on the refrigerant side. The water side of each heat exchanger shall be hydrostatically tested at 1.3 times rated working pressure.
- H. Prior to shipment, the chiller automated controls test shall be executed to check for proper wiring and ensure correct controls operation.
  - I. On chillers with unit-mounted VFD (variable frequency drive), the chiller and VFD shall be factory wired and tested together to verify proper operation prior to shipment.
  - J. The management process governing the manufacture of this chiller shall be ISO 9001:2008 certified.

##### 1.03 SUBMITTALS

- A. Submit drawings showing assembled chiller, chiller dimensions, and service clearances.
- B. Submit data indicating electrical requirements, field wiring diagrams and piping connections.

##### 1.04 DELIVERY, STORAGE AND HANDLING

- A. Manufacturer shall provide instructions for long term storage upon request.
- B. Unit shall be shipped with all refrigerant piping and control wiring factory installed.
- C. Include installation operation and maintenance manual (IOM) for both the chiller and VFD. If not in the IOM, include field piping diagrams with valves, strainers and temperature sensors required for complete system.
- D. Unit shall be shipped with firmly attached labels that indicate name of manufacturer, chiller model number, chiller serial number, and refrigerant used.
- E. If the chiller is to be exported it is recommended that export packaging be included.

##### 1.05 WARRANTY

Warranty shall include:

Parts and labor for one year after start-up or 18 months from shipment, whichever occurs first.



## 1.06 PERFORMANCE SCHEDULE AND TEST

- A. Chillers with open motors shall provide a more efficient chiller that takes into account the kW consumed by additional cooling to remove the heat created by the open motor to the equipment room. See Section 3.2-E Compressor Motor Assembly for further detail.
- B. Performance test to be performed in accordance with AHRI Standard 550/590 and 551/591, latest update and tolerances per the standard. A certified test report signed by an officer of the company shall be submitted to the owner.
- C. If the equipment fails to perform within proposed tolerances, the manufacturer will have ability to make the necessary revisions to his equipment and retest as required.

## Part 2 — System Requirements

### 2.01 GENERAL

- A. Multiple identical water-cooled centrifugal chillers in parallel with VFD pump(s), VFD on tower fan motors, plate frame heat exchanger (Integrated water side economizer) or refrigerant migration, valving, and microprocessor control system.
- B. VFD pump(s), VFD fan motors, valves, and plate frame heat exchanger supplied by others.

### 2.02 MODES OF OPERATION

Chiller should be able to perform the following modes of operation:

1. Mechanical Cooling
2. Free Cooling
  - a. Integrated water-side economizer (IWSE)
  - b. Refrigerant migration (RM)
3. Heat Recovery

### 2.03 COMPRESSOR

- A. The compressor-motor assembly shall be direct drive semi-hermetic centrifugal with multi-stage design with refrigerant lubricated ceramic.
- B. All manufacturers shall provide a quote for an itemized list of bearing components. Proposal shall include line item pricing for spare bearings. Failure to provide a quote is a disqualification.
- C. Motor type shall be induction NEMA Class B, insulation Class F.
- D. Chiller shall be able to unload to 20% of design tonnage at design temperatures and flows without gas flow circulation, load balance valve or hot gas bypass.
- E. Motors shall be suitable for operation in a refrigerant atmosphere and shall be cooled by atomized refrigerant in contact with the motor windings.
- F. Connections to the compressor casing shall use O-rings instead of gaskets to reduce the occurrence of refrigerant leakage. Connections to the compressor shall be flanged or bolted for easy disassembly.

- G. All pressure transducers shall have quick disconnects to allow replacement of the sensor without replacement of the entire sensor wire. Pressure transducers shall be capable of field calibration to ensure accurate readings and to avoid unnecessary transducer replacement. Pressure transducers and temperature sensors shall be serviceable without the need for refrigerant charge removal or isolation.

- H. Centrifugal compressors shall use variable inlet guide vanes to provide partial capacity modulation while also providing pre-whirl of the refrigerant vapor entering the impeller.

- I. Centrifugal compressors with ceramic bearings shall be provided with a factory-installed refrigerant lubrication system.

Compressor shall be fully field serviceable. Compressors which must be removed and returned to the factory for service shall be unacceptable.

### 2.04 EVAPORATOR AND CONDENSER

- A. Evaporator shall be of hybrid falling-film type construction.
  1. Waterbox shall be nozzle-in-head or marine waterbox (150 psig [1034 kPa]).
  2. Waterbox shall have standard Victaulic grooves or flanges.
- B. Condenser shall be of shell and tube type construction with shells, tube sheets and waterboxes fabricated out of carbon steel.
  1. Waterbox shall be nozzle-in-head or marine (150 psig [1034 kPa]).
  2. Waterbox shall have standard Victaulic grooves or flanges.
- C. Waterboxes shall have vents, drains, and covers to permit tube cleaning within the space shown on the drawings. A thermistor type temperature sensor with quick connects shall be factory installed in each water nozzle.
- D. ASME Compliance: Shells and connective piping fabricate and label chiller to comply with ASME Boiler Pressure Vessel Code, Section VIII, Division 1 and include an ASME U stamp and nameplate certifying compliance.
- E. Insulation shall be 3/4-in. thick neoprene to prevent sweating. The insulation shall cover all low temperature surfaces.
- F. Tubes:
  1. Individually replaceable from either end and without affecting the strength and durability of the tube sheet and without causing leakage in adjacent tubes.
  2. Mechanically expanded into the grooved end sheets and physically attached to intermediate tube sheets. Sealants alone should not be an acceptable method to seal the tubes to the end tube sheets.

3. Tube sheet holes shall be double grooved for a leak tight joint.
  4. Tubes shall be nominal  $\frac{3}{4}$  or 1-in. OD
  5. Minimum wall thickness 0.025 in.
  6. Tubing shall be copper, high-efficiency type, with internal and external enhancement.
  7. For series counterflow arrangements, both the evaporator and condenser shall be 1 pass. For parallel arrangements, the evaporator shall be 2 or 3 pass and condensers shall be 2 pass.
- G. A rupture disc type pressure relief device shall be installed on each evaporator.

## 2.05 PURGE

Manufacturers using low pressure refrigerants shall incorporate a factory installed automatic purge system for collection and return of refrigerant and for removal of non-condensables. The purge operation shall be independent of chiller.

## 2.06 REFRIGERANT FLOW CONTROL

- A. To maintain optimal part load efficiency, the refrigerant expansion device to the evaporator and as applicable to the economizer, shall use a variable metering valve, such as a float valve. To ensure optimal operating performance, the valve design will prevent refrigerant gas from the condenser passing to the evaporator at full or part load.
- B. The float valve chamber shall have a bolted access cover to allow field inspection and the float valve shall be field serviceable.
- C. Fixed orifices are not allowed.

## 2.07 CONTROLS, SAFETIES, AND DIAGNOSTICS

- A. Controls:
1. The chiller shall be provided with a factory installed and wired microprocessor control center. The microprocessor can be configured for either English or SI units.
  2. All chiller and VFD monitoring shall be displayed at the chiller control panel.
  3. The controls shall make use of non-volatile memory.
  4. The chiller control system shall have the ability to interface and communicate directly to the building control system.
  5. The default standard display screen shall simultaneously indicate the following minimum information:
    - a. date and time of day
    - b. 24-character primary system status message
    - c. 24-character secondary status message
    - d. chiller operating hours
    - e. entering chilled water temperature
    - f. leaving chilled water temperature
    - g. evaporator refrigerant temperature
    - h. entering condenser water temperature

- i. leaving condenser water temperature
  - j. condenser refrigerant temperature
  - k. percent motor rated load amps (RLA)
6. In addition to the default screen, status screens shall be accessible to view the status of every point monitored by the control center including:
- a. evaporator pressure
  - b. condenser pressure
  - c. bearing refrigerant supply temperature
  - d. compressor discharge temperature
  - e. motor winding temperature
  - f. number of compressor starts
  - g. control point settings
  - h. discrete output status of various devices
  - i. compressor motor VFD status
  - j. optional spare input channels
  - k. current and voltage for each phase
  - l. frequency

## 7. Schedule Function:

The chiller controls shall be configurable for manual or automatic start-up and shutdown. In automatic operation mode, the controls shall be capable of automatically starting and stopping the chiller according to a stored user programmable occupancy schedule. The controls shall include built-in provisions for accepting:

- a. A minimum of two 365-day occupancy schedules.
- b. Minimum of 8 separate occupied/unoccupied periods per day.
- c. Daylight savings start/end.
- d. Minimum of 16 user-defined holidays.
- e. Means of configuring an occupancy timed override.
- f. Chiller start-up and shutdown via remote contact closure.

## 8. Service Function:

The controls shall provide a password protected service function which allows authorized individuals to view an alarm history file which shall contain the last 25 alarm/alert messages with time and date stamp. These messages shall be displayed in text form, not codes.

## 9. Network Window Function:

Each chiller control panel shall be capable of viewing multiple point values and statuses from other like controllers connected on a common network, including controller maintenance data. The operator shall be able to alter the remote controller's set points or time schedule and to force point values or statuses for those points that are operator forcible. The control panel shall also have access to the alarm history file of all like controllers connected on the network.

10. Pump Control:

Upon request to start the compressor, the control system shall start the chilled water pump, condenser water pumps and verify that flows have been established.

11. Ramp Loading:

A user-configurable ramp loading rate, effective during the chilled water temperature pulldown period, shall control the rate of guide vane opening to prevent a rapid increase in compressor power consumption. The controls shall allow configuration of the ramp loading rate in either degrees/minute of chilled water temperature pulldown or percent motor amps/minute. During the ramp loading period, a message shall be displayed informing the operator that the chiller is operating in ramp loading mode.

12. Chilled Water Reset:

The control center shall allow reset of the chilled water temperature set point based on any one of the following criteria:

- a. Chilled water reset based on an external 4 to 20 mA signal.
- b. Chilled water reset based on a remote temperature sensor (such as outdoor air).
- c. Chilled water reset based on water temperature rise across the evaporator.

13. Demand Limit:

The control center shall limit amp draw of the compressor to the rated load amps or to a lower value based on one of the following criteria:

- a. Demand limit based on a user input ranging from 40% to 100% of compressor rated load amps.
- b. Demand limit based on external 4 to 20 mA signal.

14. Controlled Compressor Shutdown:

The controls shall be capable of being configured to soft stop the compressor. When the stop button is pressed or remote contacts open with this feature active, the guide vanes shall close to a configured amperage level and the machine shall then shut down. The display shall indicate "shutdown in progress."

B. Safeties:

- 1. Unit shall automatically shut down when any of the following conditions occur: (Each of these protective limits shall require manual reset and cause an alarm message to be displayed on the control panel screen, informing the operator of the shutdown cause.)
  - a. motor overcurrent
  - b. overvoltage<sup>1</sup>

- c. undervoltage<sup>1</sup>
- d. single cycle dropout<sup>1</sup>
- e. bearing refrigerant high temperature
- f. low evaporator refrigerant temperature
- g. high condenser pressure
- h. high motor temperature
- i. high compressor discharge temperature
- j. variable frequency drive fault
- k. high variable frequency drive temperature
- l. prolonged surge
- m. loss of evaporator water flow
- n. loss of condenser water flow
- o. low bearing differential pressure

2. The control system shall detect conditions that approach protective limits and take self-corrective action prior to an alarm occurring. The system shall automatically reduce chiller capacity when any of the following parameters are outside their normal operating range:

- a. high condenser pressure
- b. high motor temperature
- c. low evaporator refrigerant temperature
- d. surge prevention control
- e. high motor amps

3. During the capacity override period, a pre-alarm (alert) message shall be displayed informing the operator which condition is causing the capacity override. Once the condition is again within acceptable limits, the override condition shall be terminated and the chiller shall revert to normal chilled water control. If during either condition the protective limit is reached, the chiller shall shut down and a message shall be displayed informing the operator which condition caused the shutdown and alarm.

4. Internal built-in safeties shall protect the chiller from loss of water flow. Differential pressure switches shall not be allowed to be the only form of freeze protection.

C. Diagnostics and Service:

- 1. A self-diagnostic controls test shall be an integral part of the control system to allow quick identification of malfunctioning components.
- 2. Once the controls test has been initiated, all pressure and temperature sensors shall be checked to ensure they are within normal operating range. A pump test shall automatically energize the chilled water pump, and condenser water pump. The control system shall confirm that water flow has been established and require operator confirmation before proceeding to the next test. A guide vane actuator test shall open and close the guide vanes to check for proper operation. The operator manually acknowledges

---

1. Shall not require manual reset or cause an alarm if auto-restart after power failure is enabled.

proper guide vane operation prior to proceeding to the next test.

## Part 3 — Jobsite Requirements

### 3.01 ELECTRICAL REQUIREMENTS

- A. Electrical contractor shall supply and install main electrical power line, disconnect switches, circuit breakers, and electrical protection devices per local code requirements and as indicated necessary by the chiller manufacturer.
- B. Electrical contractor shall wire the chilled water pump, condenser water pump, and tower fan control circuit to the chiller control circuit.
- C. Electrical contractor shall supply and install electrical wiring and devices required to interface the chiller controls with the building control system if applicable.
- D. Electrical power shall be supplied to the unit at the voltage, phase, and frequency listed in the equipment schedule.

### 3.02 PIPING REQUIREMENTS—INSTRUMENTATION AND SAFETIES

- A. Mechanical contractor shall supply and install pressure gages in readily accessible locations in piping adjacent to the chiller such that they can be easily read from a standing position on the floor. Scale range shall be such that design values shall be indicated at approximately mid-scale.
- B. Gages shall be installed in the entering and leaving water lines of the evaporator and condenser.

### 3.03 VIBRATION ISOLATION

Chiller manufacturer shall furnish neoprene isolator pads for mounting equipment on a level concrete surface.

### 3.04 START-UP

- A. The chiller manufacturer shall provide a factory-trained representative, employed by the chiller manufacturer, to perform the start-up procedures as outlined in the Start-up, Operation and Maintenance manual provided by the chiller manufacturer.
- B. Manufacturer shall supply the following literature:
  - 1. Start-up, operation and maintenance instructions.
  - 2. Installation instructions.
  - 3. Field wiring diagrams.
  - 4. One complete set of certified drawings.

### 3.05 SPECIAL FEATURES

- A. Soleplate Package Accessory:  
Unit manufacturer shall furnish a soleplate package consisting of soleplates, jacking screws, leveling pads, and neoprene pads.
- B. Spring Isolators Accessory:  
Field furnished and selected for the desired degree of isolation.
- C. Spare Sensors with Leads Accessory:  
Unit manufacturer shall furnish additional temperature sensors and leads.

### D. Refrigerant Charge:

Chiller shall be shipped with dry nitrogen charge.

### E. Thermal Insulation:

Unit manufacturer shall insulate the evaporator shell, economizer low side compressor suction elbow, motor shell and motor cooling lines. Insulation shall be  $\frac{3}{4}$  in. (19 mm) thick with a thermal conductivity not exceeding 0.28 (Btu in.)/hr ft<sup>2</sup> °F [(0.0404 • W)/(m • °C)] and shall conform to UL standard 94, classification 94 HBF.

### F. Optional Envelope Stability Control:

Modulating valve and piping shall be factory furnished to permit stable chiller operation at low loads.

### G. Evaporator and Condenser Tubes:

Contact local Carrier representative for other tube offerings.

### H. Nozzle-In-Head, 300 psig (2068 kPa):

Unit manufacturer shall furnish nozzle-in-head style waterboxes on the cooler and/or condenser rated at 300 psig (2068 kPa).

### I. Marine Waterboxes, 150 psig (1034 kPa):

Unit manufacturer shall furnish marine style waterboxes on evaporator and/or condenser rated at 150 psig (1034 kPa).

### J. Marine Waterboxes, 300 psig (2068 kPa):

Unit manufacturer shall furnish marine style waterboxes on evaporator and/or condenser rated at 300 psig (2068 kPa).

### K. Flanged Waterbox Nozzles:

Unit manufacturer shall furnish standard flanged piping connections on the evaporator and/or condenser.

### L. Hinges:

Unit manufacturer shall furnish hinges on waterboxes to facilitate tube cleaning.

### M. BACnet<sup>1</sup> Communication Option:

Shall provide factory-installed communication capability with a BACnet network.

## Part 4 — Variable Frequency Drive Requirements

### 4.01 UNIT MOUNTED VFD WITH 1% LINE REACTOR AND 4% DC CHOKE

- A. The compressor motor starter VFD shall be factory mounted, wired and tested prior to shipment by the chiller manufacturer. Customer electrical connection for compressor motor power shall be limited to main power leads to the starter, and wiring water pumps and tower fans to the chiller control circuit.
  - 1. Totally Enclosed Non-Ventilated (TENV) enclosure with integral fan coil cooling and lockable hinged doors.
  - 2. Main power fused disconnect.

---

1. BACnet is a registered trademark of ASHRAE (American Society of Heating, Refrigerating, and Air-Conditioning Engineers).



3. Capability to start and stop chiller, pumps and tower fans.
  4. 4 kva control transformer.
  5. Branch circuit fuse to provide power for refrigerant pump.
  6. Branch circuit fuse to provide power for control power.
  7. Branch circuit fuse to provide for purge panel.
  8. The following are standard features:
    - a. Phase loss
    - b. Phase reversal
    - c. Phase imbalance
    - d. 3-phase ground fault
    - e. Low voltage—phase to phase and phase to ground
    - f. Current overload
    - g. 3-phase under/over voltage
    - h. Microprocessor based overload trip protection
    - i. Line frequency, line current, line voltage, load current, load power, load frequency values are displayed on PIC 5 control panel.
    - j. Input voltage surge suppression
- B. VFD Design and Components
1. Design:
    - a. VFD shall be air or refrigerant cooled, microprocessor based, pulse width modulated (PWM) design. Water-cooled drive is not acceptable.
    - b. If water-cooled is provided, the following must be done on a yearly basis, coolant solution must be replaced, cooling system must be flushed out, strainer cleaned, and shell and tube heat exchanger tubes must be cleaned.
    - c. Input power device shall be full wave SCR diode bridge
    - d. Input 6 pulse rectifier shall convert incoming AC voltage to DC voltage. Input current and voltage shall be regulated.
    - e. Transistorized inverter and control regulator (V/f) shall convert DC voltage to a sinusoidal PWM waveform.
    - f. Integrated chiller controls shall coordinate motor speed and guide vane position to optimize chiller performance over all chiller operating conditions.
    - g. Surge prevention and surge protection algorithms shall take action to prevent surge and move chiller operation away from surge.
  2. Enclosure:
    - a. Pre-painted unit mounted, Totally Enclosed Non-Ventilated (TENV) cabinet shall include hinged, lockable doors and removable lifting lugs.
      - b. VFD shall have a short circuit interrupt of 100,000 amps.
      - c. Provisions to padlock main disconnect handle in the “Off” positions shall be provided.
      - d. Provisions shall be made for top entry of incoming line power cables.
  3. Heat Sink:
    - a. The heat sink shall be air-cooled.
    - b. Refrigerant cooling shall be metered by microprocessor control solenoid valve to maintain temperature within acceptable limits for VFD enclosure temperature.
    - c. Water-cooled VFD heat exchangers (cold plate and fan coil) are not acceptable.
  4. VFD Rating:
    - a. Drive shall be suitable for continuous operation at nameplate voltage  $\pm 10\%$ .
    - b. Drive shall be suitable for continuous operation at 100% of nameplate amps and 150% of nameplate amps for 5 seconds.
    - c. Drive shall comply with applicable ANSI, NEMA, UL and NEC standards.
    - d. Drive shall be suitable for operation in ambient temperatures between 32 and 104°F (0 and 40°C), 95% humidity (non-condensing) for altitudes up to 3300 ft (1000 m) above sea level without derating. Specific drive performance at jobsite ambient temperature and elevation shall be provided by the manufacturer in the bid.
  5. User Interface:
 

A single display shall provide interface for programming and display of VFD and chiller parameters. Viewable parameters include:

    - a. Operating, configuration and fault messages
    - b. Frequency in Hz
    - c. Load and line side voltage and current (at the VFD)
    - d. kW (line and load side)
    - e. IGBT temperatures
  6. VFD Performance:
    - a. VFD voltage total harmonic distortion (THD) and harmonic current total demand distortion (TDD) shall not exceed 35% TDD requirements using the VFD disconnect input terminals as the point of common coupling (PCC).
    - b. VFD full load efficiency shall meet or exceed 97% at 100% VFD rated ampacity.
    - c. Input 6 pulse rectifier shall regulate unity displacement power factor to 0.95 or higher at full load.
    - d. Soft start, linear acceleration, coast to stop.



## Guide specifications (cont)

7. VFD Electrical Service (single point power):
  - a. VFD shall have input fused disconnect with minimum 100,000 amp interrupt capacity.
  - b. VFD shall have standard 4 kva power transformer with fuse provides power VFD controls and chiller controls.
  - c. The refrigerant pump fuse, purge unit fuse and control power transformer shall be factory wired.
  - d. Nameplate voltage shall range between 380 and 480  $\pm 10\%$ , 3 phase, 50/60 Hz  $\pm 5$  Hz.
8. Discrete Outputs:

115 v discrete contact outputs shall be provided for field wired:

  - a. Chilled water pump
  - b. Condenser water pump
  - c. Alarm status
  - d. Tower fan low
  - e. Tower fan high
9. Analog Output:

An analog (4 to 20 mA) output for head pressure reference shall be provided. This signal

shall be suitable to control a 2-way or 3-way water regulating valve in the condenser piping.

10. Protection (the following shall be supplied):
  - a. Under-voltage
  - b. Over voltage
  - c. Over current
  - d. Phase loss
  - e. Phase reversal
  - f. Ground fault
  - g. Phase unbalance protection
  - h. Single cycle voltage loss protection
  - i. Programmable auto re-start after loss of power
  - j. Motor overload protection (NEMA Class 10)
11. VFD Testing:

The compressor motor starter VFD shall be factory mounted, wired and tested prior to shipment by the chiller manufacturer.