



## Product Data

# AquaEdge® High-Efficiency Semi-Hermetic Centrifugal Liquid Chillers

50/60 Hz, HFC-134a  
200 to 3400 Nominal Tons (703 to 11957 kW)



19XR,XRV  
SINGLE-STAGE  
COMPRESSOR

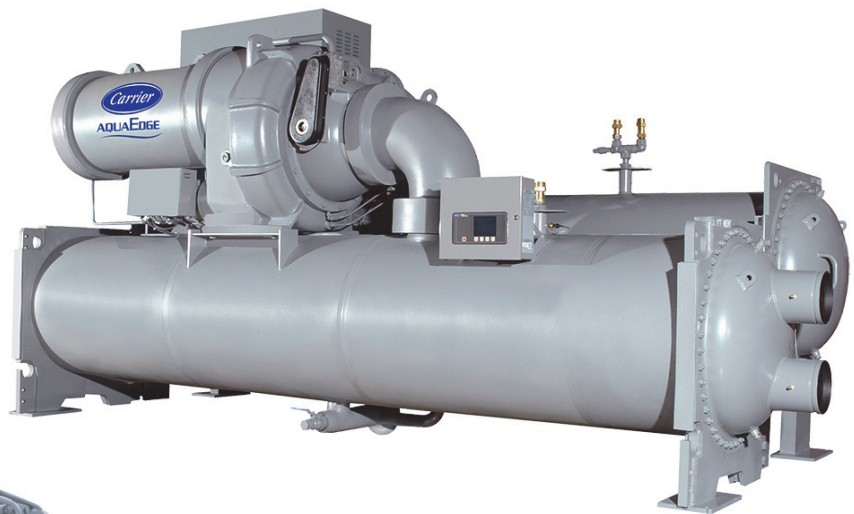

19XR  
TWO-STAGE  
COMPRESSOR



19XR and 19XRV are both High-Efficiency Semi-Hermetic Centrifugal Liquid Chillers; 19XRV features Greenspeed® Intelligence

The Carrier-designed AquaEdge® family of chillers achieves high efficiencies without compromising the environment.

Carrier's AquaEdge® centrifugal chillers offer:

- The use of non-ozone depleting refrigerant HFC-134a
- An annual leak rate of 0.1%, one of the lowest published in the industry
- The ability to store the entire charge of refrigerant inside the chiller, minimizing the chance of leaks during refrigerant transfer for maintenance
- Semi-hermetic compression
- Free-standing medium voltage VFD (variable frequency drive) (option)
- Modular construction
- Positive pressure design
- Variable diffuser optimization logic, which can improve the integrated part load values (IPLV) (available on compressor frame sizes 4 and 5 with diffuser control enabled)
- Single stage (200 to 1600 tons)
- Two stage (800 to 3400 tons)

The AquaEdge chiller efficiency levels meet or exceed energy efficiency requirements of ASHRAE (American Society of Heating, Refrigerating and Air-Conditioning Engineers) 90.1-2016.

The AquaEdge chillers' high efficiencies are obtained at true operating conditions. Therefore, the effects of potential direct or indirect global warming are greatly diminished.

## High efficiency

Today's owners of chilled water plants demand high efficiency from their chillers. Per AHRI (Air-Conditioning, Heating and Refrigeration Institute) 550/590 and 551/591, chillers operate at design conditions less than one percent of the time.

As a result, superior part load efficiency is required for today's chilled water applications.

The AquaEdge 19XR centrifugal chiller is offered as a fixed-speed machine or with an optional free-standing variable speed drive to maximize part load efficiency. The 19XRV chiller is equipped with a factory-installed variable speed drive.

Enabling diffuser control on the AquaEdge chiller (available on compressor frame sizes 4 and 5) improves the chiller's part load efficiency by increasing the diffuser opening. Diffuser position is not only based on inlet guide vane (IGV) position, but also on lift.

## Environmental leadership

Carrier has long been committed to the environment and its sustainability. AquaEdge chillers provide our customers with a high-efficiency, chlorine-free solution. Carrier's decision to utilize non-ozone depleting HFC-134a refrigerant provides our customers with a safer and more environmentally balanced choice without compromising efficiency.

## Reliability

The AquaEdge chiller's single-stage or two-stage positive-pressure compressor, coupled with ASME (American Society of Mechanical Engineers) constructed heat exchangers, provides high reliability and sustainability. Carrier's semi-hermetic motors operate in a clean-liquid, refrigerant-cooled environment. The semi-hermetic design eliminates the potential for shaft seal leaks and refrigerant/oil loss. These are just some of the reasons why the AquaEdge® family of chillers has one of the industry's lowest leak rates.

## Positive pressure design

The AquaEdge chiller's positive pressure design reduces the chiller size by up to 35% compared to low-pressure designs. The smaller size minimizes the need for valuable mechanical room floor space. In addition, positive pressure designs eliminate the need for costly low-pressure containment devices, reducing the initial cost of the system.

## The AquaEdge chiller advantage

The AquaEdge chiller can be shipped fully charged, minimizing start-up and maintenance time. Purge units are not required. The tight construction of the AquaEdge centrifugal chiller ensures that contaminants stay out and efficiency is maintained throughout the life of the chiller.

## Modular construction

The cooler, condenser, economizer, and compressor assemblies are completely bolted together, making the AquaEdge chillers ideally suited for replacement projects where ease of disassembly and reassembly at the jobsite are essential.

## Marine container shipment (19XR, heat exchanger frame sizes 1 to 6 only)

The compact design allows for open-top container shipment to export destinations, ensuring product quality while reducing shipping cost.

## Optional refrigerant isolation valves

This system allows the refrigerant to be stored inside the chiller during servicing, reducing refrigerant loss and eliminating time-consuming transfer procedures. As self-contained units, the AquaEdge chillers do not require additional remote storage systems.

## Optional pumpdown unit

Combined with the refrigerant isolation valves listed above, the optional pumpdown unit eliminates complex connections to portable transfer systems, thereby reducing service costs. In addition, the optional pumpdown compressor meets Environmental Protection

# Table of contents

	Page
Features/Benefits . . . . .	2
Model Number Nomenclature . . . . .	8
Chiller Components . . . . .	10
Physical Data . . . . .	16
Options and Accessories . . . . .	53
Dimensions . . . . .	55
Selection Procedure . . . . .	59
Electrical Data/Ratings . . . . .	59
Controls . . . . .	60
Typical Piping and Wiring . . . . .	61
Application Data . . . . .	63
Guide Specifications . . . . .	81

Agency's (EPA's) vacuum level requirements that mandate minimizing refrigerant emissions during service.

### Optional unit-mounted starter

Available in low-voltage wye-delta and solid state, Carrier's unit-mounted starter provides a single point power connection, reducing chiller installation time and expense. (Available on heat exchanger frame sizes 1 to 7 only.)

### Optional seismic kit

A seismic isolation package is available on select models to meet International Building Code and ASCE (American Society of Civil Engineers) 7 seismic qualification requirements in concurrence with ICC ES (International Code Council Evaluation Service) AC156 Acceptance Criteria for Seismic Qualification by Shake-Table Testing of Nonstructural Components and Systems.

### Semi-hermetic compressor features

**Hydrodynamic journal bearings** are featured for the fully supported motor shaft, and roller element bearings are featured for the high-speed impeller shaft for improved efficiency.

**Pipe diffuser** design uses jet engine technology, increasing centrifugal compressor peak efficiency (single-stage only).

**Motors** are hermetically sealed from the machine room; cooling is accomplished by spraying liquid refrigerant on the motor windings. This highly efficient motor cooling method results in the use of smaller, cooler-running motors than could be realized with air-cooled designs of the same type.

In addition, Carrier's semi-hermetic design eliminates:

- Compressor shaft seals that require maintenance and increase the likelihood of refrigerant leaks
- Shaft alignment problems that occur with open-drive designs during start-up and operation, when equipment temperature variations cause thermal expansion
- High noise levels that are common with air-cooled motors, which radiate noise to the machine room and adjacent areas
- Machine room cooling requirements associated with air-cooled motors,

which dissipate heat to the machine room

**High-efficiency copper rotor** motors are available on select models.

**Compressors are 100% run-tested** to ensure proper operation of all compressor systems, including oil management, vibration, electrical, power transmission, and compression.

### Heat exchanger features

**The American Society of Mechanical Engineers (ASME) standard** requires the use of an independent agency to certify the design, manufacture, and testing of all heat exchangers, ensuring the ultimate in heat exchanger safety, reliability, and long life.

**Refrigerant-cooled VFD (19XRV)** helps reduce VFD size and ensures proper cooling of the transistors for extended life. Using R-134a refrigerant instead of water also eliminates costly maintenance associated with the water cooling pump, heat exchanger and rubber tubing used with water-cooled VFDs.

**1-in. tubes (optional)** provide optimized cost and less pressure drop than the default 3/4-in. tubes.

**Tube expansion** at center support sheets prevents unwanted tube movement and vibration, thereby reducing the possibility of premature tube failure.

**Double-grooved tube sheet holes** reduce the possibility of leaks between the water and refrigerant system, increasing product reliability.

**Condenser baffle** prevents direct impingement of high velocity compressor gas onto the condenser tubes. The baffle eliminates the related vibration and wear of the tubes and distributes the refrigerant flow evenly over the length of the vessel for improved efficiency.

**Closely spaced intermediate support sheets** prevent tube sagging and vibration, thereby increasing heat exchanger life.

**Refrigerant filter drier isolation valves** allow filter replacement without pumping down the chiller, which means less service time and less expense.

**FLASC (flash subcooler)**, located in the bottom of the condenser, increases the refrigeration effect by cooling condensed liquid refrigerant to a lower

temperature, resulting in reduced compressor power consumption.

**Ball-type or linear float valves** provide precise refrigerant metering over a wide variety of operating conditions. As a result, optimal refrigerant levels can be maintained in the condenser and cooler to achieve the greatest efficiency without unintentional hot gas bypass or flooding.

### Microprocessor control features

**Direct digital Product Integrated Control (PIC)** provides unmatched flexibility and functionality. Each unit integrates directly with the Carrier Comfort Network® (CCN) system, providing a system solution to controls applications. The PIC control can be configured to display units in English or metric, and provides unparalleled ease of operation.

The default display offers all-in-one glance review of key chiller operation data, simplifying the interaction between chiller and user.

Features include:

- Display of over 125 operating, status, and diagnostic messages for improved user interface
- Monitoring of over 100 functions and conditions to protect the chiller from abnormal conditions
- Modular pull-out/plug-in design, reducing wiring requirements and providing easy installation
- Low-voltage (24 v) design, providing the ultimate assurance of personal safety and control integrity

The display modes include 4 standard languages:

- English
- Chinese
- Japanese (PIC II and PIC III only)
- Korean (PIC II and PIC III only)

Other languages are available.

**Automatic capacity override** function unloads the compressor whenever key safety limits are approached, increasing unit life.

**Chilled water reset** can be accomplished manually or automatically from the building management system. Reset saves energy when warmer chilled water can be used.

**Demand limiting** feature limits the power draw of the chiller during peak loading conditions. When incorporated into the Carrier Comfort Network®



building automation system, a red line command holds chillers at their present capacity and prevents any other chillers from starting. If a load shed signal is received, the compressors are unloaded to avoid high demand charges whenever possible.

**Ramp loading** ensures a smooth pulldown of water loop temperature and prevents a rapid increase in compressor power consumption during the pulldown period.

**Automated controls test** can be executed prior to start-up to verify that the entire control system is functioning properly.

**365-day real time clock** feature allows the operator to program a yearly schedule for each week, weekends, and holidays.

**Occupancy schedules** can be programmed into the controller to ensure that the chiller only operates when cooling is required.

**Extensive service menu** features include password protection to prevent unauthorized access to the service menu. Built-in diagnostic capabilities assist in troubleshooting and recommend proper corrective action for pre-set alarms, resulting in greater operating time.

**Alarm file** maintains the last 25 time and date-stamped alarm and alert messages in memory; this function reduces troubleshooting time and cost.

**Configuration data backup** in non-volatile memory provides protection during power failures and eliminates time-consuming control reconfiguration.

## 19XR refrigeration cycle

The compressor continuously draws refrigerant vapor from the cooler at a rate set by the amount of guide vane opening. As the compressor suction reduces the pressure in the cooler, the remaining refrigerant boils at a fairly low temperature (typically 38 to 42°F [3 to 6°C]). The energy required for boiling is obtained from the water flowing through the cooler tubes. With heat energy removed, the water becomes cold enough to use in an air-conditioning circuit or process liquid cooling.

After taking heat from the water, the refrigerant vapor is compressed. Compression adds still more heat energy and the refrigerant is quite warm (typically 98 to 102°F [37 to 40°C]) when it is discharged from the compressor into the condenser.

Relatively cool (typically 65 to 90°F [18 to 32°C]) water flowing into the condenser tubes removes heat from the refrigerant, and the vapor condenses to liquid.

The liquid refrigerant passes through orifices into the FLASC (flash subcooler) chamber. Since the FLASC chamber is at a lower pressure, part of the liquid refrigerant flashes to vapor, thereby cooling the remaining liquid. The FLASC vapor is recondensed on

the tubes which are cooled by entering condenser water. The liquid drains into a float valve chamber between the FLASC chamber and cooler. Here, the AccuMeter™ float valve forms a liquid seal to keep FLASC chamber vapor from entering the cooler. When liquid refrigerant passes through the valve, some of it flashes to vapor in the reduced pressure on the cooler side. In flashing, it removes heat from the remaining liquid. The refrigerant is now at a temperature and pressure at which the cycle began. Refrigerant from the condenser also cools the motor, oil and optional variable speed drive.

The refrigeration cycle for a 19XR, XRV chiller with two-stage compressor is similar to the one described above, with the following exception: Liquid refrigerant from the condenser flows into an economizer at intermediate pressure. In the economizer, vapor is separated from the liquid; the separated vapor flows to the second stage of the compressor and the liquid flows into the cooler. Since the economizer gas has to pass through only half of the compression cycle to reach condenser pressure, a saving in power is achieved. The energy removed from the vaporized refrigerant allows the liquid refrigerant in the cooler to absorb more heat when it evaporates and thereby benefits the cooling cycle.



### REFRIGERATION CYCLE 19XR, XRV SINGLE-STAGE COMPRESSOR

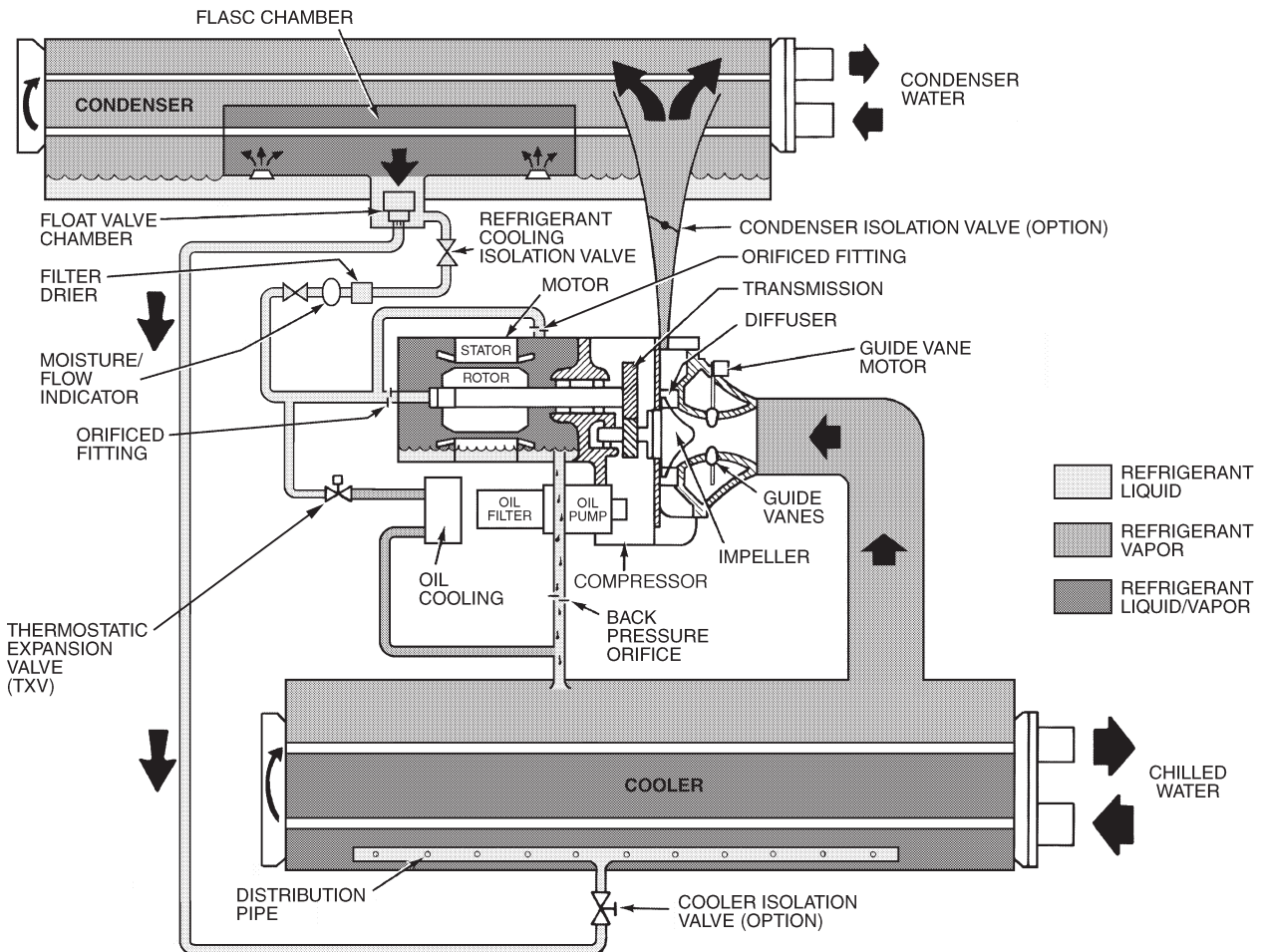
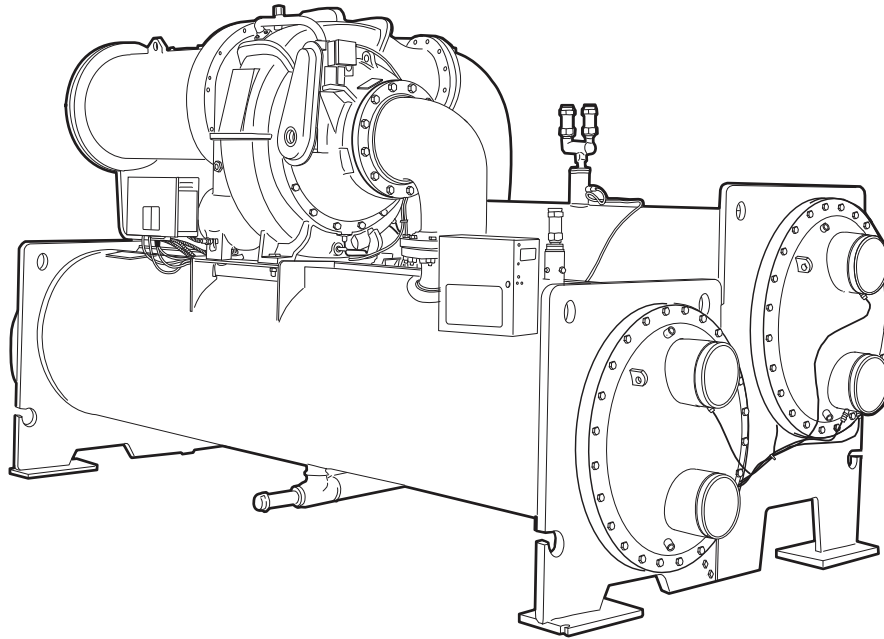

## REFRIGERATION CYCLE (CONT) 19XR, XRV TWO-STAGE COMPRESSOR FRAME SIZE E

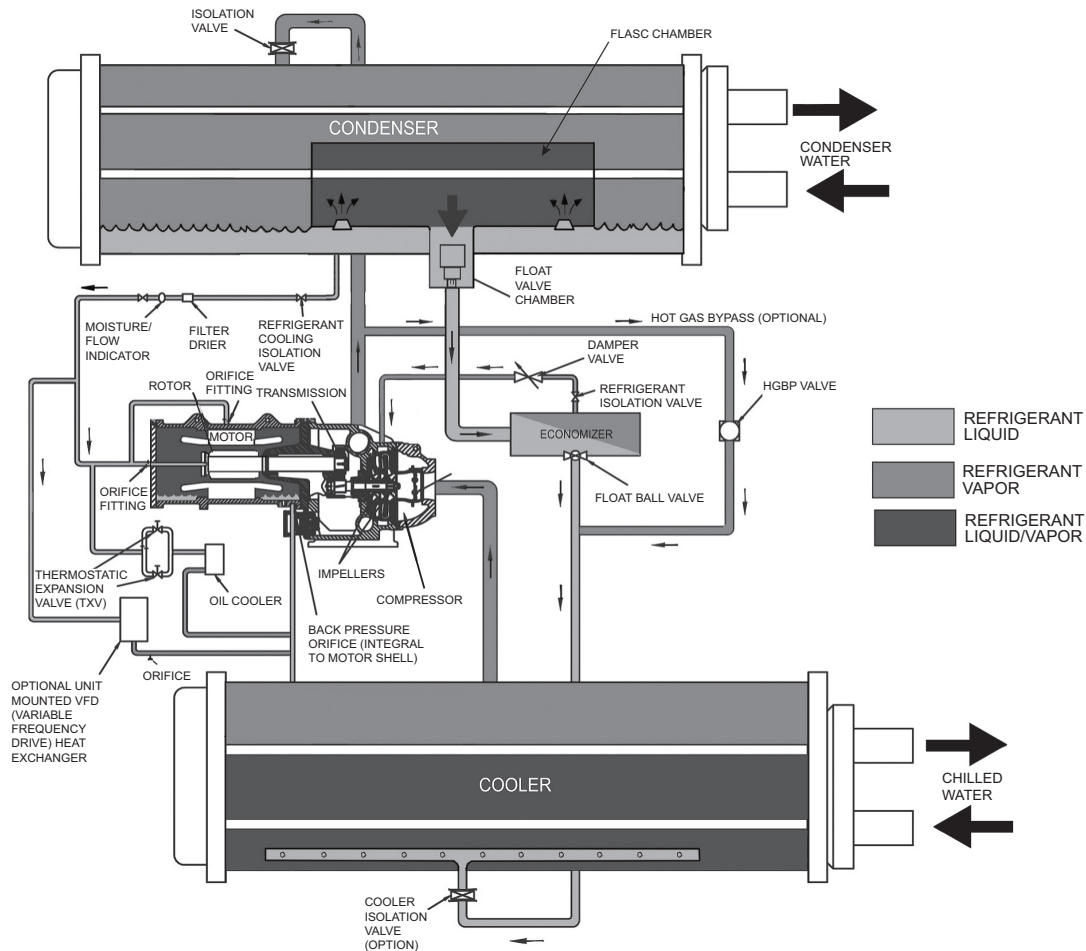
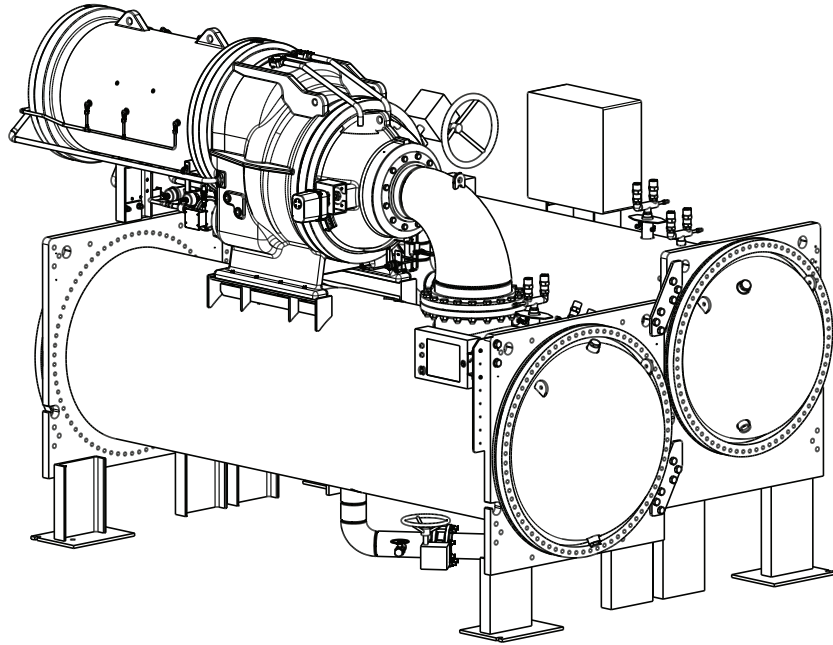

**REFRIGERATION CYCLE (CONT)**  
**19XR TWO-STAGE COMPRESSOR FRAME SIZES 6 AND 7**

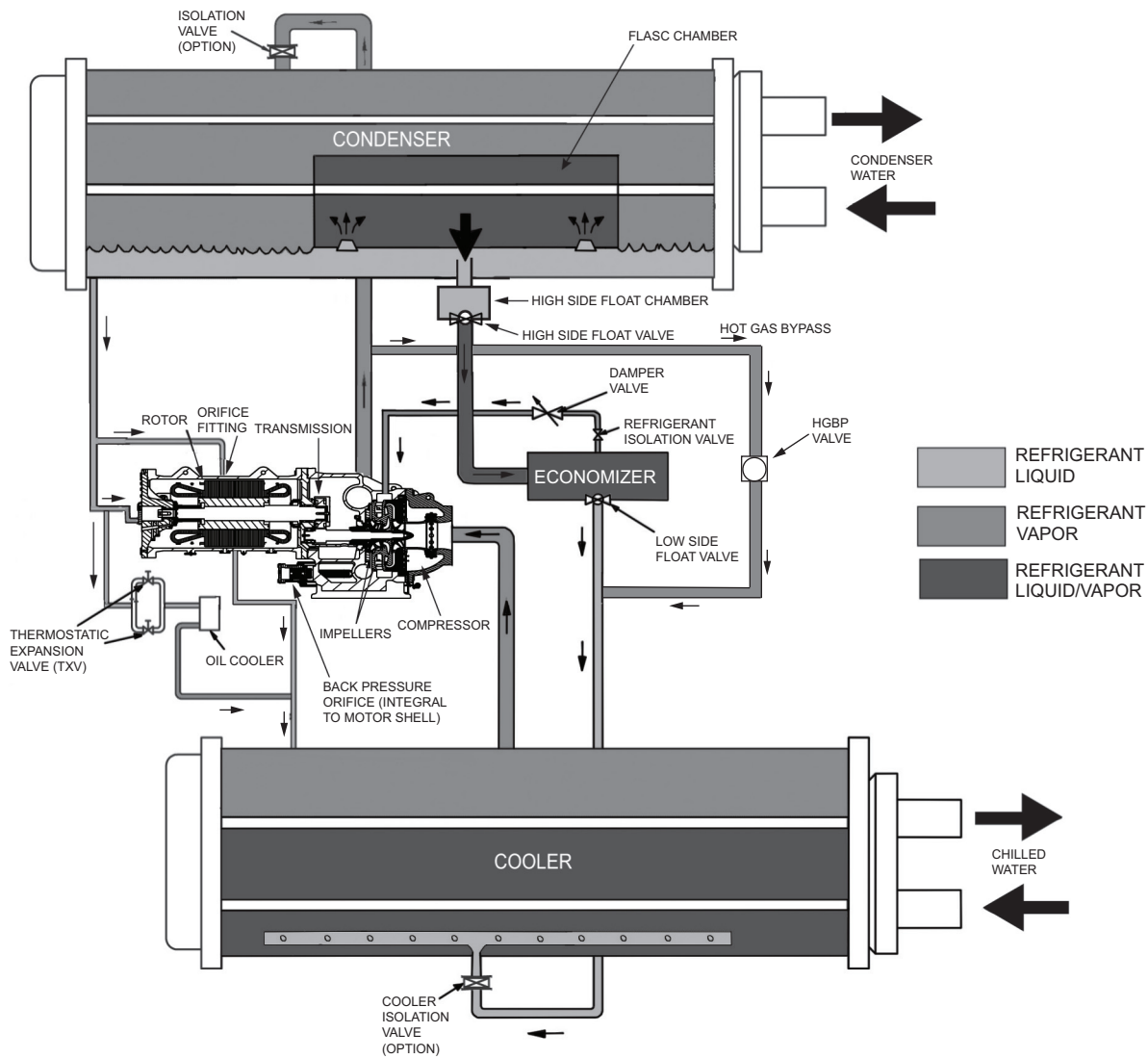



# Model number nomenclature



## 19XR,XRV SINGLE-STAGE COMPRESSOR AND TWO-STAGE COMPRESSOR FRAME SIZE E

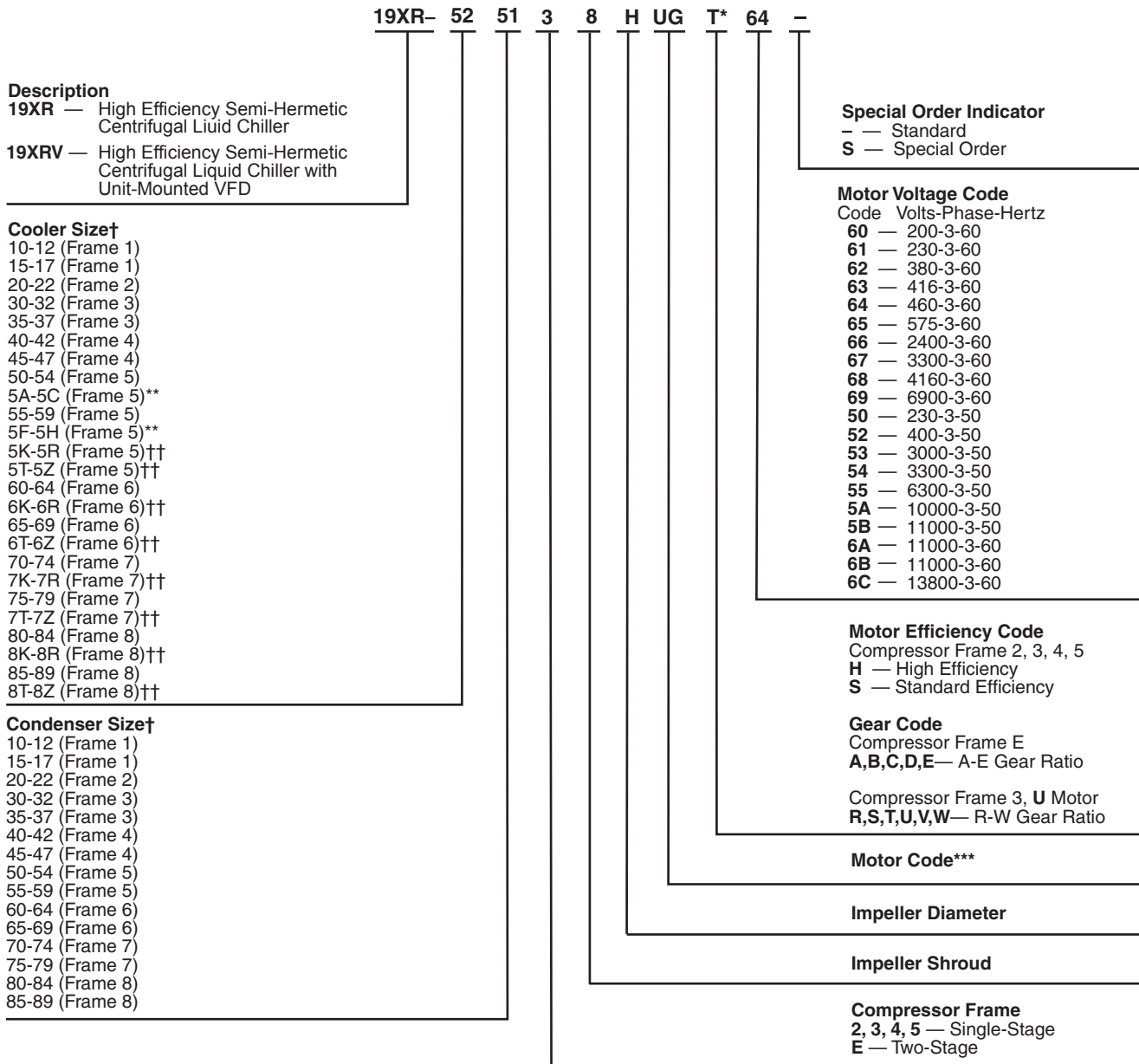

Quality Assurance  
ISO 9001:2008 certified processes



Water-Cooled Water Chilling and Heat Pump Water-Heating Packages  
AHRI Standards 550/590 and 551/591  
AHRI (Air-Conditioning, Heating, and Refrigeration Institute)  
Performance Certified

### SEISMICOMPLIANT\*

\* Meets IBC 2006, ASCE-7-05, CBC 2007, and OSHPD seismic requirements.  
Seismic rating available on select models.

\* Digit 15 will refer to the Gear Code for the following models:

1. Digit 10 (Compressor Frame) is E or
2. Digit 10 (Compressor Frame) is 3 and Digit 13 of the Motor Code is U.

† Frame sizes 1 through 6 available on single-stage units only.

\*\* Refer to 19XR,XRV Computer Selection Program for details on these sizes.

†† Frame sizes with K-R and T-Z are with 1-in. OD evaporator tubing.

\*\*\* Refer to the 19XR,XRV Computer Selection Program for motor size details.

## 19XR TWO-STAGE COMPRESSOR FRAME SIZE 6 AND 7

	19XR-	A45	A47	636	M	N	7	-
<b>Description</b> <b>19XR</b> — High Efficiency Semi-Hermetic Centrifugal Liquid Chiller								
<b>Cooler Size Code (Digits 6, 7, 8)</b> A40-A42 A45-A47 A4A-A4C* A4F-A4H* A60-A62 A65-A67 A6A-A6C* A6F-A6H* B60-B62† B65-B67† B80-B82† B85-B87† B6A-B6C*† B6F-B6H*† B8A-B8C*† B8F-B8H*† C60-C62† C65-C67† C80-C82† C85-C87† C6A-C6C*† C6F-C6H*† C8A-C8C*† C8F-C8H*†								
<b>Condenser Size Code (Digits 9, 10, 11)</b> A40-A42 A45-A47 A4A-A4C* A4F-A4H* A60-A62 A65-A67 A6A-A6C* A6F-A6H* B40-B42 B45-B47 B4A-B4C* B4F-B4H* B60-B62* B65-B67* B6A-B6C* B6F-B6H* C60-C62† C65-C67† C80-C82† C85-C87† C6A-C6C*† C6F-C6H*† C8A-C8C*† C8F-C8H*† D60-D62† D65-D67† D80-D82† D85-D87† D6A-D6C*† D6F-D6H*† D8A-D8C*† D8F-D8H*†								
								<b>Special Order Indicator</b> - — Standard S — Special Order
								<b>Motor Voltage Code</b> Code Volts-Phase-Hertz 2 — 400-3-50 (19XR6 only) 4 — 3000-3-50 5 — 3300-3-50 6 — 6300-3-50 7 — 10000-3-50 8 — 11000-3-50 A — 380-3-60 (19XR6 only) C — 460-3-60 (19XR6 only) E — 2400-3-60 F — 3300-3-60 G — 4160-3-60 H — 6900-3-60 J — 11000-3-60 K — 13800-3-60
								<b>Motor Size Code</b> Compressor Frame Size 6 N — 1500 HP P — 1625 HP Q — 1750 HP R — 1875 HP S — 2000 HP T — 2100 HP Compressor Frame Size 7 U — 2250 HP V — 2375 HP W — 2500 HP X — 2625 HP Y — 2750 HP Z — 2900 HP
								<b>Gear Code</b> Compressor Frame Size 6 E J M P Compressor Frame Size 7 R T V X Y
								<b>Compressor Size Code</b> <b>Frame Size (12th Digit)</b> 6 — Frame Size 6 7 — Frame Size 7 <b>Shroud Size (13th Digit)</b> 1 (Frame Size 7 Only) 2 3 4 (Frame Size 6 Only) <b>Impeller Diameter (14th Digit)</b> 2 4 6 8 0

\* Frame sizes with A-C and F-H are with 1-in. OD tubing.  
 †Heat exchanger available with frame 7 compressor only.



**Quality Assurance**  
 ISO 9001:2008 certified processes  
 AHRI (Air-Conditioning, Heating, and Refrigeration Institute)  
 Performance Certified  
 Compliance with UL 1995  
 (CSA C22.2 No. 236)

## COMPRESSOR COMPONENTS 19XR,XRV SINGLE-STAGE COMPRESSOR

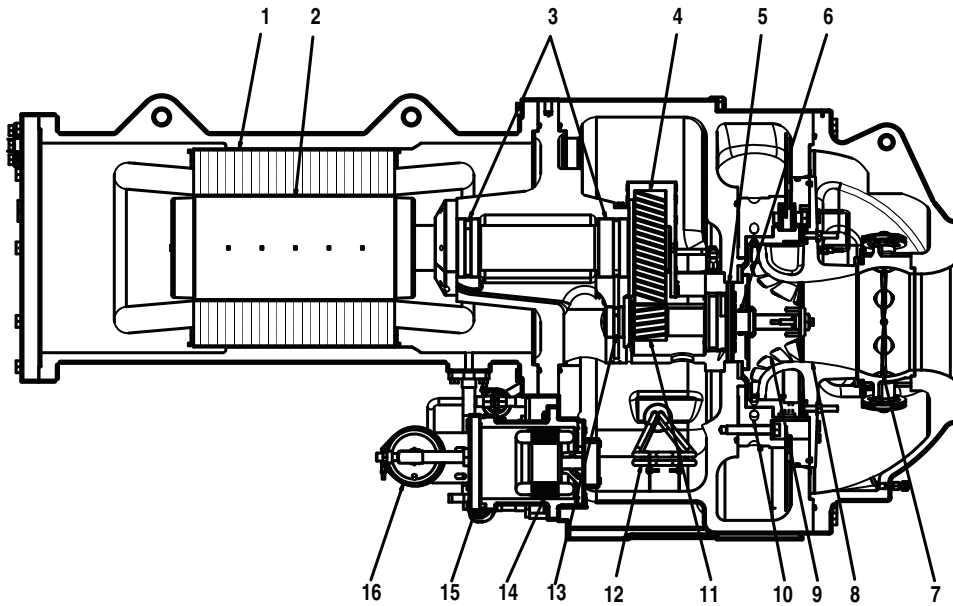

### LEGEND

- |                                     |                               |
|-------------------------------------|-------------------------------|
| 1 — Motor Stator                    | 9 — Impeller                  |
| 2 — Motor Rotor                     | 10 — Pipe Diffuser            |
| 3 — Motor Shaft Journal Bearings    | 11 — High Speed Pinion Gear   |
| 4 — Low Speed Bull Gear             | 12 — Oil Heater               |
| 5 — High Speed Shaft Thrust Bearing | 13 — High Speed Shaft Bearing |
| 6 — High Speed Shaft Bearing        | 14 — Oil Pump Motor           |
| 7 — Variable Inlet Guide Vanes      | 15 — Oil Pump Cover           |
| 8 — Impeller Shroud                 | 16 — Oil Filter               |



**COMPRESSOR COMPONENTS  
19XR,XRV TWO-STAGE COMPRESSOR FRAME SIZE E**

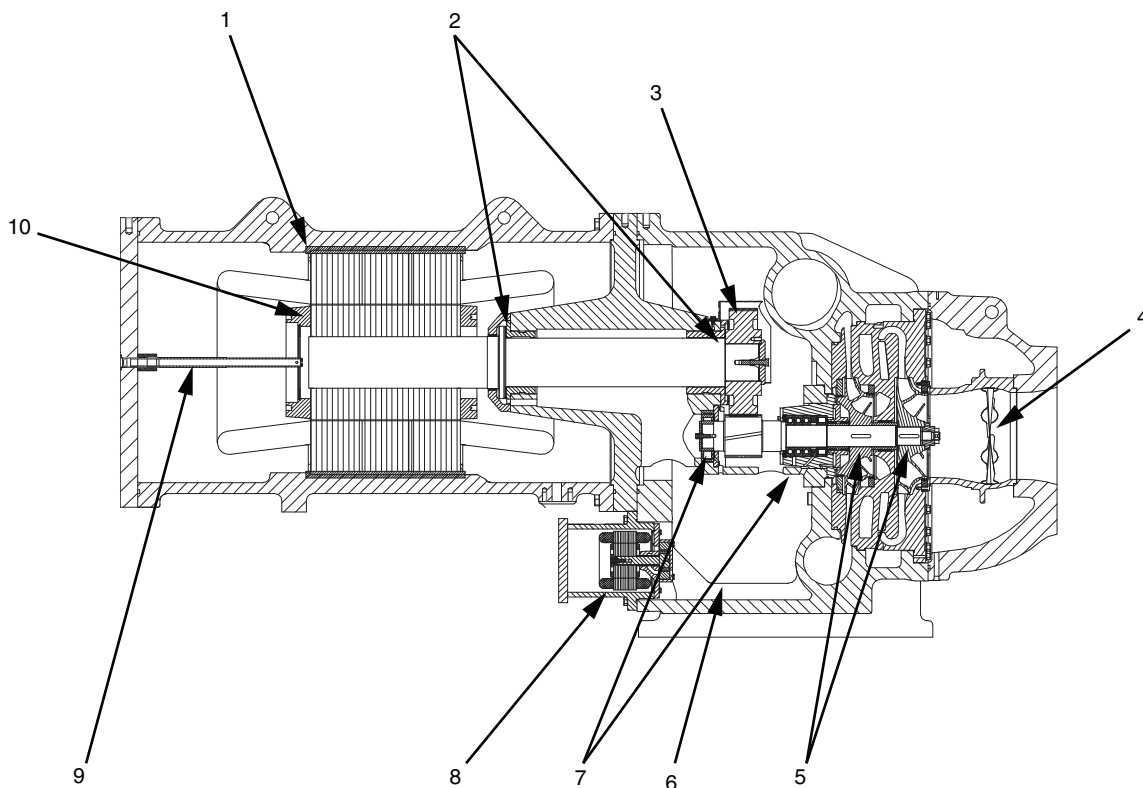

**LEGEND**

- |                                |                               |
|--------------------------------|-------------------------------|
| 1 — Motor Stator               | 6 — Oil Heater                |
| 2 — Motor Shaft Bearings       | 7 — High Speed Shaft Bearings |
| 3 — Transmission               | 8 — Oil Pump                  |
| 4 — Variable Inlet Guide Vanes | 9 — Motor Cooling             |
| 5 — Impellers                  | 10 — Motor Rotor              |

## COMPRESSOR COMPONENTS 19XR TWO-STAGE COMPRESSOR FRAME SIZES 6 AND 7

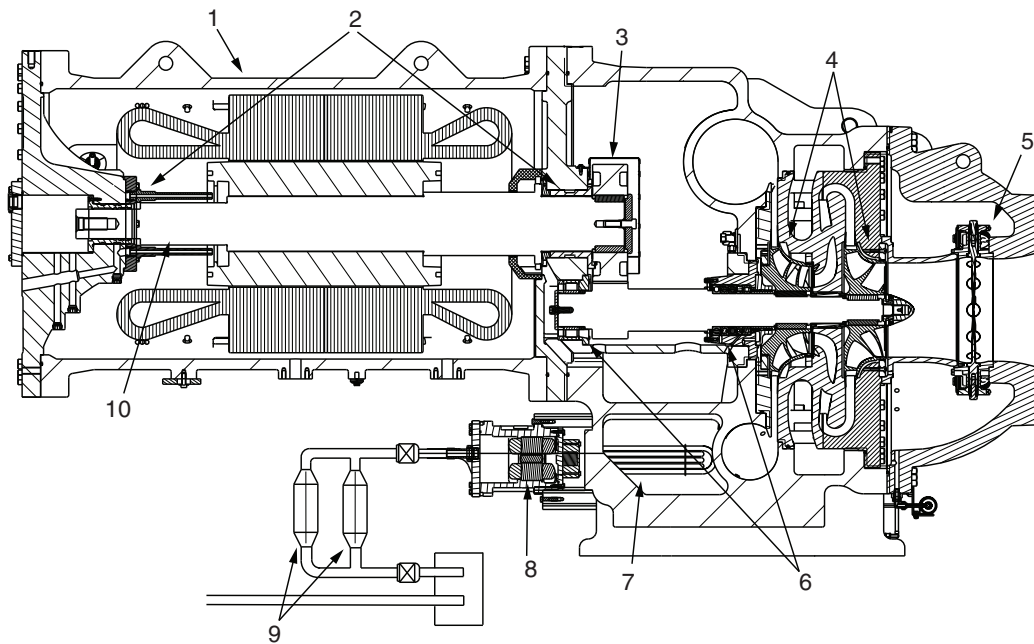

### LEGEND

- |                                |                               |
|--------------------------------|-------------------------------|
| 1 — Motor Stator               | 6 — High Speed Shaft Bearings |
| 2 — Motor Shaft Bearings       | 7 — Oil Heater                |
| 3 — Transmission               | 8 — Oil Pump                  |
| 4 — Impellers                  | 9 — Oil Filters               |
| 5 — Variable Inlet Guide Vanes | 10 — Motor Rotor              |

## 19XR, XRV SINGLE-STAGE COMPRESSOR

FRONT VIEW

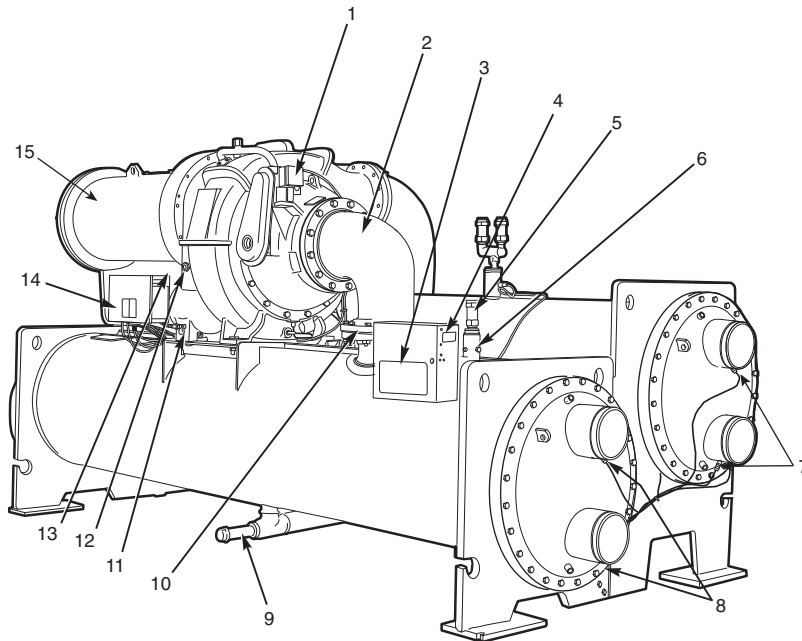

LEGEND

- 1 — Guide Vane Actuator
- 2 — Suction Elbow
- 3 — International Chiller Visual Control (ICVC)
- 4 — Chiller Identification Nameplate
- 5 — Cooler Auto Reset Relief Valves
- 6 — Cooler Pressure Transducer
- 7 — Condenser In/Out Temperature Thermistors
- 8 — Cooler In/Out Temperature Thermistors
- 9 — Refrigerant Storage Tank Connection Valve
- 10 — Typical Flange Connection
- 11 — Oil Drain Valve
- 12 — Oil Level Sight Glasses
- 13 — Refrigerant Oil Cooler (Hidden)
- 14 — Auxiliary Power Panel
- 15 — Motor Housing

REAR VIEW

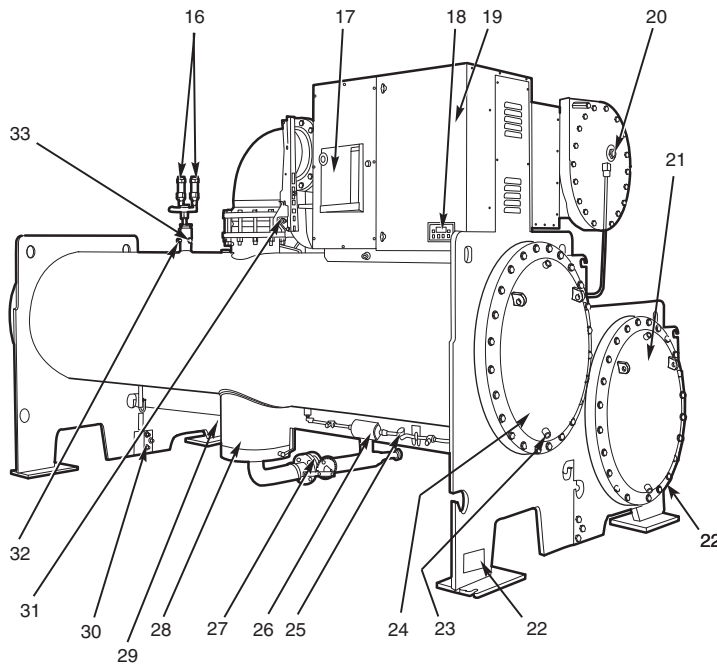

LEGEND

- 16 — Condenser Auto. Reset Relief Valves
- 17 — Motor Circuit Breaker
- 18 — Solid-State Starter Control Display
- 19 — Unit-Mounted Starter or VFD (Optional)  
Solid-State Starter Shown
- 20 — Motor Sight Glass
- 21 — Cooler Return-End Waterbox Cover
- 22 — ASME Nameplate (One Hidden)
- 23 — Typical Waterbox Drain Port
- 24 — Condenser Return-End Waterbox Cover
- 25 — Refrigerant Moisture/Flow Indicator
- 26 — Refrigerant Filter/Drier
- 27 — Liquid Line Isolation Valve (Optional)
- 28 — Liquid Float Valve Chamber
- 29 — Refrigerant Charging Valve (Hidden)
- 30 — Vessel Take-Apart Connector
- 31 — Discharge Isolation Valve (Optional)
- 32 — Condenser Pressure Transducer
- 33 — Refrigerant Charging Valve/Pumpout Connection



## 19XR,XRV TWO-STAGE COMPRESSOR FRAME SIZE E

FRONT VIEW

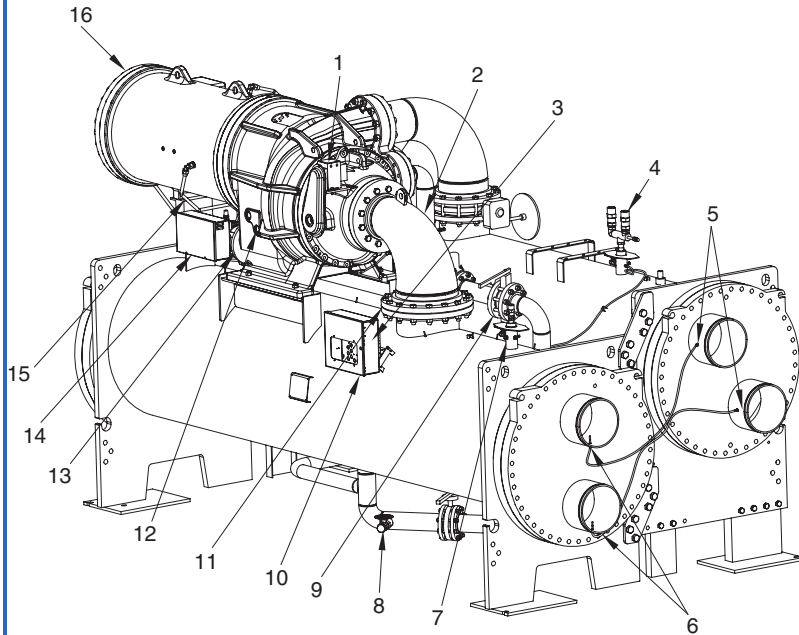

LEGEND

- 1 — Guide Vane Actuator
- 2 — Suction Elbow
- 3 — Chiller Identification Nameplate
- 4 — Condenser Auto Reset Relief Valves
- 5 — Condenser In/Out Temperature Thermistors
- 6 — Cooler In/Out Temperature Thermistors
- 7 — Cooler Pressure Transducer
- 8 — Refrigerant Storage Tank Connection Valve
- 9 — Refrigerant Isolation Valve
- 10 — Chiller Visual Controller/ International Chiller Visual Control (ICVC)
- 11 — Typical Flange Connection
- 12 — Oil Level Sight Glasses
- 13 — Oil Drain Charging Valve
- 14 — Auxiliary Power Panel
- 15 — Refrigerant Oil Cooler (Hidden)
- 16 — Compressor Motor Housing

REAR VIEW

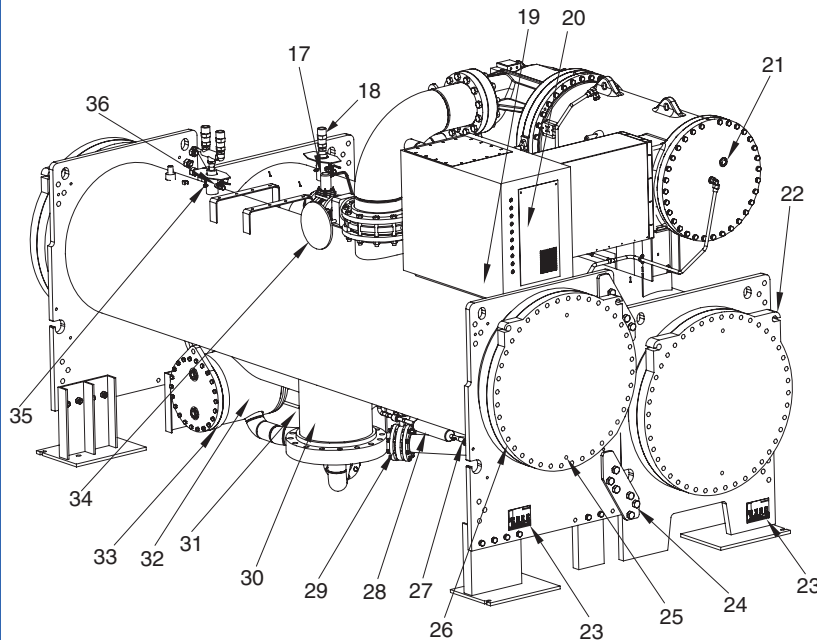

LEGEND

- 17 — Damper Valve (Hidden)
- 18 — Cooler Auto. Reset Relief Valves
- 19 — Solid-State Starter Control Display (Optional)
- 20 — Unit-Mounted Starter (Optional)
- 21 — Motor Sight Glass
- 22 — Cooler Return-End Waterbox Cover
- 23 — ASME Nameplate
- 24 — Vessel Take-Apart Connector
- 25 — Typical Waterbox Drain Port
- 26 — Condenser Return-End Waterbox Cover
- 27 — Refrigerant Moisture/Flow Indicator
- 28 — Refrigerant Filter/Drier
- 29 — Liquid Line Isolation Valve (Optional)
- 30 — Linear Float Valve Chamber
- 31 — Refrigerant Charging Valve (Hidden)
- 32 — Economizer Float Ball Valve Assembly (Inside)
- 33 — Economizer Assembly
- 34 — Discharge Isolation Valve (Optional)
- 35 — Condenser Pressure Transducer
- 36 — Refrigerant Charging Valve/Pumpout Connection

## 19XR TWO-STAGE COMPRESSOR FRAME SIZES 6 AND 7

### FRONT VIEW

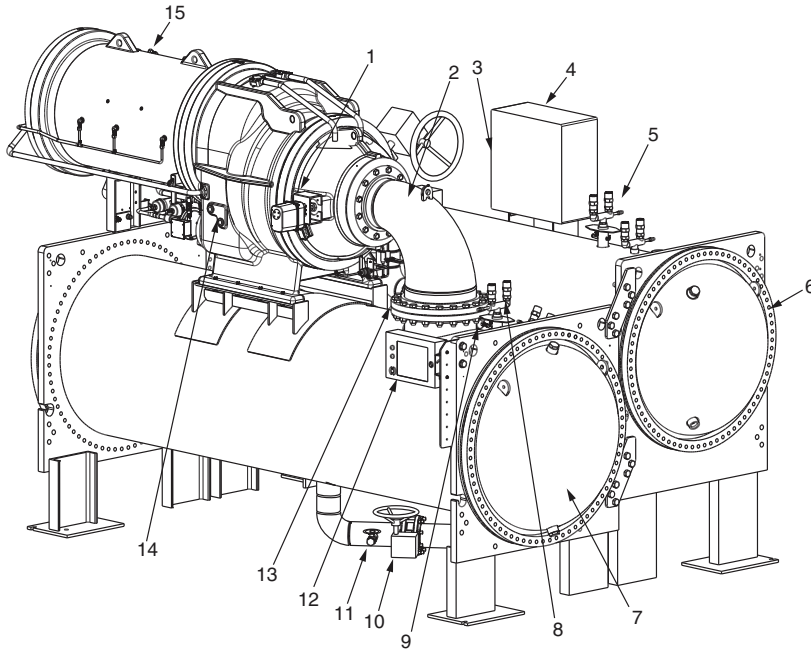

#### LEGEND

- 1 — Guide Vane Actuator\*
- 2 — Suction Elbow
- 3 — Chiller Identification Nameplate
- 4 — Auxiliary Power Panel
- 5 — Condenser Auto. Reset Relief Valves
- 6 — Condenser Return End Waterbox Cover
- 7 — Cooler Return End Waterbox Cover
- 8 — Cooler Auto. Reset Relief Valves
- 9 — Cooler Pressure Transducer
- 10 — Liquid Line Isolation Valve (Optional)
- 11 — Refrigerant Storage Tank Connection Valve
- 12 — HMI (Human Machine Interface) Panel
- 13 — Typical Flange Connection
- 14 — Oil Level Sight Glasses
- 15 — Compressor Motor Housing

\*See certified drawing for Frame 7 location.

### REAR VIEW

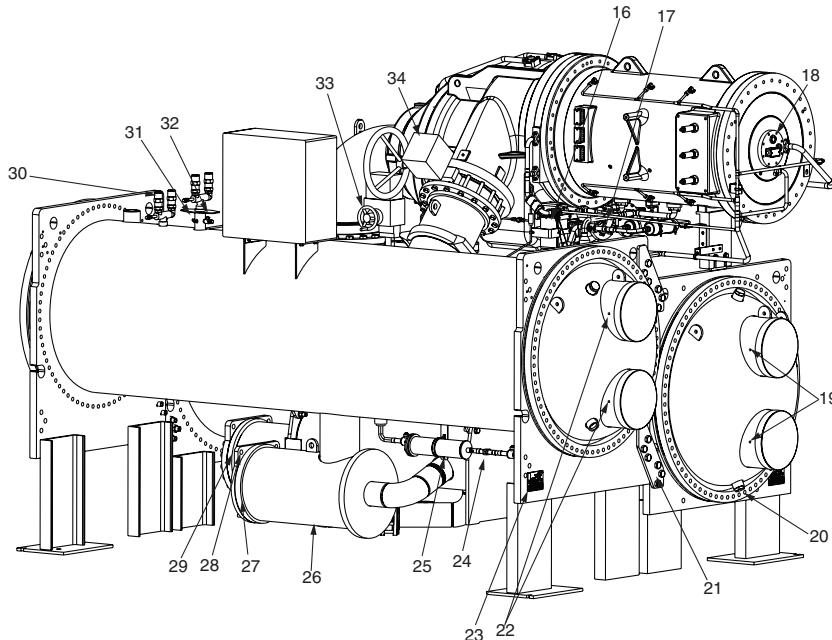

#### LEGEND

- 16 — Oil Cooler
- 17 — Oil Drain Changing Valve (Hidden)
- 18 — Motor Sight Glass
- 19 — Cooler In/Out Temperature Thermistors
- 20 — Typical Waterbox Drain Port
- 21 — Vessel Take-Apart Connector
- 22 — Condenser In/Out Temperature Thermistors
- 23 — ASME Nameplate
- 24 — Refrigerant Moisture/Flow Indicator
- 25 — Refrigerant Filter/Drier
- 26 — High Side Float Chamber
- 27 — High Side Float Ball Valve Assembly (Inside)
- 28 — Economizer Assembly
- 29 — Economizer Float Ball Assembly (Inside)
- 30 — Cooler Auto. Reset Relief Valve
- 31 — Condenser Pressure Transducer
- 32 — Refrigerant Charging Valve/Pumpout Connection
- 33 — Damper Valve
- 34 — Discharge Isolation Valve (Optional)

NOTE: Frame 6 is shown.

## 19XR,XRV COMPRESSOR AND MOTOR WEIGHTS\*— STANDARD AND HIGH-EFFICIENCY MOTORS COMPRESSOR FRAME SIZE 2†

MOTOR CODE	ENGLISH						SI					
	Compressor Weight** (lb)	60 Hz		50 Hz		End Bell Cover Weight (lb)	Compressor Weight** (kg)	60 Hz		50 Hz		End Bell Cover Weight (kg)
		Stator Weight†† (lb)	Rotor Weight (lb)	Stator Weight†† (lb)	Rotor Weight (lb)			Stator Weight†† (kg)	Rotor Weight (kg)	Stator Weight†† (kg)	Rotor Weight (kg)	
<b>STANDARD-EFFICIENCY MOTORS / LOW VOLTAGE (200-575 V)</b>												
BDS	2300	900	190	915	205	185	1043	408	86	415	93	84
BES	2300	915	200	965	220	185	1043	415	91	438	100	84
BFS	2300	975	215	1000	230	185	1043	442	98	454	104	84
BGS	2300	1000	230	1060	250	185	1043	454	104	481	113	84
BHS	2300	1030	240	1105	265	185	1043	467	109	501	120	84
BJS	2300	1105	265	—	—	185	1043	501	120	—	—	84
<b>HIGH-EFFICIENCY MOTORS / LOW VOLTAGE (200-575 V)</b>												
BDH	2300	1030	240	1030	240	185	1043	467	109	467	109	84
BEH	2300	1070	250	1070	250	185	1043	485	113	485	113	84
BFH	2300	1120	265	1120	265	185	1043	508	120	508	120	84
BGH	2300	1175	290	1175	290	185	1043	533	132	533	132	84
BHH	2300	1175	290	1175	290	185	1043	533	132	533	132	84
BJH	2300	1175	290	—	—	185	1043	533	132	—	—	84
JBH	2300	1003	226	1063	248	185	1043	455	103	482	112	84
JCH	2300	1063	248	1113	263	185	1043	482	112	505	119	84
JDH	2300	1113	263	1149	278	185	1043	505	119	521	126	84
JEH	2300	1149	278	1196	295	185	1043	521	126	542	134	84
JFH	2300	1196	295	—	—	185	1043	542	134	—	—	84

\* Total compressor weight is the sum of the compressor aerodynamic components (compressor weight column), stator, rotor, and end bell cover weights.

† See Model Number Nomenclature on page 8.

\*\* Compressor aerodynamic component weight only, motor weight not included. Applicable to standard compressors only. For high lift compressors, contact Carrier Chiller Marketing for weights.

† Stator weight includes the stator and shell.

**19XR,XRV COMPRESSOR AND MOTOR WEIGHTS\*—  
STANDARD AND HIGH-EFFICIENCY MOTORS (CONT)  
COMPRESSOR FRAME SIZE 3†**

MOTOR CODE	ENGLISH						SI					
	Compressor Weight** (lb)	60 Hz		50 Hz		End Bell Cover Weight (lb)	Compressor Weight** (kg)	60 Hz		50 Hz		End Bell Cover Weight (kg)
		Stator Weight†† (lb)	Rotor Weight (lb)	Stator Weight†† (lb)	Rotor Weight (lb)			Stator Weight†† (kg)	Rotor Weight (kg)	Stator Weight†† (kg)	Rotor Weight (kg)	
<b>STANDARD-EFFICIENCY MOTORS / LOW VOLTAGE (200-575 V)</b>												
CBS	2816	1146	219	1188	236	274	1277	520	99	539	107	124
CCS	2816	1171	227	1196	242	274	1277	531	103	542	110	124
CDS	2816	1198	237	1258	255	274	1277	543	108	571	116	124
CES	2816	1207	240	1272	258	274	1277	547	109	577	117	124
CLS	2816	1247	249	1328	273	274	1277	566	113	602	124	124
CMS	2816	1270	257	1353	278	274	1277	576	117	614	126	124
CNS	2816	1321	266	1386	282	274	1277	599	121	629	128	124
CPS	2816	1334	269	1401	287	274	1277	605	122	635	130	124
CQS	2816	1353	276	1408	290	274	1277	614	125	639	132	124
CRS	2816	1259	321	—	—	274	1277	571	146	—	—	124
CRS (380V)	2816	1328	346	—	—	274	1277	602	157	—	—	124
<b>HIGH-EFFICIENCY MOTORS / LOW VOLTAGE (200-575 V)</b>												
CBH	2816	1235	239	1290	254	274	1277	560	108	585	115	124
CCH	2816	1260	249	1295	259	274	1277	572	113	587	117	124
CDH	2816	1286	258	1358	273	274	1277	583	117	616	124	124
CEH	2816	1305	265	1377	279	274	1277	592	120	625	127	124
CLH	2816	1324	271	1435	292	274	1277	601	123	651	132	124
CMH	2816	1347	275	1455	298	274	1277	611	125	660	135	124
CNH	2816	1358	278	1467	301	274	1277	616	126	665	137	124
CPH	2816	1401	290	1479	304	274	1277	635	132	671	138	124
CQH	2816	1455	304	1479	304	274	1277	670	138	671	138	124
KBH	2816	1313	276	1353	285	274	1277	596	125	614	129	124
KCH	2816	1353	285	1381	291	274	1277	614	129	626	132	124
KDH	2816	1381	291	1417	307	274	1277	626	132	643	139	124
KEH	2816	1417	307	1441	313	274	1277	643	139	654	142	124
KFH	2816	1441	313	1470	320	274	1277	654	142	667	145	124
KGH	2816	1470	320	1505	333	274	1277	667	145	683	151	124
KHH	2816	1505	333	—	—	274	1277	683	151	—	—	124
UB	2816	1371	316	1391	330	274	1277	622	143	631	150	124
UC	2816	1391	330	1419	344	274	1277	631	150	644	156	124
UD	2816	1419	344	1455	372	274	1277	644	156	660	169	124
UE	2816	1455	372	1479	386	274	1277	660	169	671	175	124
UF	2816	1479	386	1508	400	274	1277	671	175	684	181	124
UG	2816	1508	400	1543	421	274	1277	684	181	700	191	124
UH	2816	1543	421	—	—	274	1277	700	191	—	—	124

\* Total compressor weight is the sum of the compressor aerodynamic components (compressor weight column), stator, rotor, and end bell cover weights.

\*\* Compressor aerodynamic component weight only, motor weight not included. Applicable to standard compressors only. For high lift compressors, contact Carrier Chiller Marketing for weights.

† See Model Number Nomenclature on page 8.

†† Stator weight includes the stator and shell.

## 19XR,XRV COMPRESSOR AND MOTOR WEIGHTS\*— STANDARD AND HIGH-EFFICIENCY MOTORS (CONT) COMPRESSOR FRAME SIZE 4†

MOTOR CODE	ENGLISH						SI					
	Compressor Weight** (lb) Fixed Ring/ Split Ring	60 Hz		50 Hz		End Bell Cover Weight (lb)	Compressor Weight** (kg) Fixed Ring/ Split Ring	60 Hz		50 Hz		End Bell Cover Weight (kg)
		Stator Weight†† (lb)	Rotor Weight (lb)	Stator Weight†† (lb)	Rotor Weight (lb)			Stator Weight†† (kg)	Rotor Weight (kg)	Stator Weight†† (kg)	Rotor Weight (kg)	
<b>STANDARD-EFFICIENCY MOTORS / LOW VOLTAGE (200-575 V)</b>												
DBS	3425 / 4211	1570	324	1725	347	236	1554 / 1910	712	147	782	157	107
DCS	3425 / 4211	1580	326	1737	352	236	1554 / 1910	717	148	788	160	107
DDS	3425 / 4211	1595	329	1749	357	236	1554 / 1910	723	149	793	162	107
DES	3425 / 4211	1685	345	1762	365	236	1554 / 1910	764	156	799	166	107
DFS	3425 / 4211	1690	348	1801	372	236	1554 / 1910	767	158	817	169	107
DGS	3425 / 4211	1692	352	1858	386	236	1554 / 1910	767	160	843	175	107
DHS	3425 / 4211	1774	366	1904	398	236	1554 / 1910	805	166	864	181	107
DJS	3425 / 4211	—	—	2020	401	318	1554 / 1910	—	—	916	182	142
<b>STANDARD-EFFICIENCY MOTORS / MEDIUM VOLTAGE (2400-4160 V)</b>												
DBS	3425 / 4211	1524	296	1637	327	236	1554 / 1910	691	134	743	148	107
DCS	3425 / 4211	1569	307	1685	354	236	1554 / 1910	712	139	764	161	107
DDS	3425 / 4211	1588	313	1713	357	236	1554 / 1910	720	142	777	162	107
DES	3425 / 4211	1613	324	1746	360	236	1554 / 1910	732	147	792	163	107
DFS	3425 / 4211	1675	347	1811	381	236	1554 / 1910	760	157	821	173	107
DGS	3425 / 4211	1704	355	1998	422	236 (60 Hz) 318 (50 Hz)	1554 / 1910	773	161	906	191	107 (60 Hz) 142 (50 Hz)
DHS	3425 / 4211	1737	361	2056	443	236 (60 Hz) 318 (50 Hz)	1554 / 1910	788	164	933	201	107 (60 Hz) 142 (50 Hz)
DJS	3425 / 4211	1769	365	2101	464	236 (60 Hz) 318 (50 Hz)	1554 / 1910	802	166	953	210	107 (60 Hz) 142 (50 Hz)
<b>STANDARD-EFFICIENCY MOTORS / MEDIUM VOLTAGE (6300-6900 V)</b>												
DDS	3425 / 4211	1919	423	2069	458	318	1554 / 1910	870	192	938	208	142
DES	3425 / 4211	1939	428	2089	463	318	1554 / 1910	880	194	947	210	142
DFS	3425 / 4211	1989	448	2139	478	318	1554 / 1910	902	203	970	217	142
DGS	3425 / 4211	2054	473	—	—	318	1554 / 1910	932	215	—	—	142
DHS	3425 / 4211	2099	488	—	—	318	1554 / 1910	952	221	—	—	142
DJS	3425 / 4211	2159	508	—	—	318	1554 / 1910	979	230	—	—	142
<b>HIGH-EFFICIENCY MOTORS / LOW VOLTAGE (200-575 V)</b>												
DBH	3425 / 4211	1773	406	1827	406	318	1554 / 1910	804	184	829	184	142
DCH	3425 / 4211	1827	406	1827	414	318	1554 / 1910	829	184	829	188	142
DDH	3425 / 4211	1827	414	1881	422	318	1554 / 1910	829	188	853	191	142
DEH	3425 / 4211	1881	422	1881	422	318	1554 / 1910	853	191	853	191	142
DFH	3425 / 4211	1881	439	1963	439	318	1554 / 1910	853	199	890	199	142
DGH	3425 / 4211	1963	455	1963	455	318	1554 / 1910	890	206	890	206	142
DHH	3425 / 4211	1963	455	2050	463	318	1554 / 1910	890	206	930	210	142
DJH	3425 / 4211	—	—	2050	471	318	1554 / 1910	—	—	930	213	142
DKH	3425 / 4211	2050	471	—	—	318	1554 / 1910	930	214	—	—	142

\* Total compressor weight is the sum of the compressor aerodynamic components (compressor weight column), stator, rotor, and end bell cover weights.

† See Model Number Nomenclature on page 8.

\*\* Compressor aerodynamic component weight only, motor weight not included. Applicable to standard compressors only. For high lift compressors, contact Carrier Chiller Marketing for weights.

†† Stator weight includes the stator and shell.



**19XR,XRV COMPRESSOR AND MOTOR WEIGHTS\*—  
STANDARD AND HIGH-EFFICIENCY MOTORS (CONT)  
COMPRESSOR FRAME SIZE 4† (CONT)**

MOTOR CODE	ENGLISH						SI					
	Compressor Weight** (lb) Fixed Ring/ Split Ring	60 Hz		50 Hz		End Bell Cover Weight (lb)	Compressor Weight** (kg) Fixed Ring/ Split Ring	60 Hz		50 Hz		End Bell Cover Weight (kg)
		Stator Weight†† (lb)	Rotor Weight (lb)	Stator Weight†† (lb)	Rotor Weight (lb)			Stator Weight†† (kg)	Rotor Weight (kg)	Stator Weight†† (kg)	Rotor Weight (kg)	
<b>HIGH-EFFICIENCY MOTORS / LOW VOLTAGE (200-575 V)</b>												
LBH	3425 / 4211	1873	364	1939	389	318	1554 / 1910	850	165	880	176	144
LCH	3425 / 4211	1939	389	2023	406	318	1554 / 1910	880	176	918	184	144
LDH	3425 / 4211	2023	406	2043	417	318	1554 / 1910	918	184	927	189	144
LEH	3425 / 4211	2043	417	2096	434	318	1554 / 1910	927	189	951	197	144
LFH	3425 / 4211	2096	434	2133	444	318	1554 / 1910	951	197	968	201	144
LGH	3425 / 4211	2133	444	2199	458	318	1554 / 1910	968	201	997	208	144
LHH	3425 / 4211	2199	458	2066	437	318	1554 / 1910	997	208	937	198	144
<b>HIGH-EFFICIENCY MOTORS / MEDIUM VOLTAGE (2400-4160 V)</b>												
DBH	3425 / 4211	1950	405	1950	405	318	1554 / 1910	885	184	885	184	144
DCH	3425 / 4211	1950	405	2025	429	318	1554 / 1910	885	184	919	195	144
DDH	3425 / 4211	1950	405	2025	429	318	1554 / 1910	885	184	919	195	144
DEH	3425 / 4211	2025	429	2100	452	318	1554 / 1910	919	195	953	205	144
DFH	3425 / 4211	2025	429	2100	452	318	1554 / 1910	919	195	953	205	144
DGH	3425 / 4211	2100	452	2200	480	318	1554 / 1910	953	205	998	218	144
DHH	3425 / 4211	2100	452	2320	575	318	1554 / 1910	953	205	1052	261	144
DJH	3425 / 4211	2100	452	2320	587	318	1554 / 1910	953	205	1052	266	144
DKH	3425 / 4211	2320	587	—	—	318	1554 / 1910	1052	266	—	—	144
<b>HIGH-EFFICIENCY MOTORS / MEDIUM VOLTAGE (6300-6900 V)</b>												
DDH	3425 / 4211	2150	536	2250	546	318	1554 / 1910	975	243	1021	248	144
DEH	3425 / 4211	2150	550	2250	550	318	1554 / 1910	975	249	1021	249	144
DFH	3425 / 4211	2250	575	2380	567	318	1554 / 1910	1021	261	1080	261	144
DGH	3425 / 4211	2250	599	2380	599	318	1554 / 1910	1021	272	1080	272	144
DHH	3425 / 4211	2380	604	2380	604	318	1554 / 1910	1080	274	1080	274	144
DJH	3425 / 4211	2380	614	2380	614	318	1554 / 1910	1080	279	1080	279	144
DKH	3425 / 4211	2380	614	—	—	318	1554 / 1910	1080	279	—	—	144

\* Total compressor weight is the sum of the compressor aerodynamic components (compressor weight column), stator, rotor, and end bell cover weights.

\*\* Compressor aerodynamic component weight only, motor weight not included. Applicable to standard compressors only. For high lift compressors, contact Carrier Chiller Marketing for weights.

† See Model Number Nomenclature on page 8.

†† Stator weight includes the stator and shell.

# Physical data (cont)



## 19XR,XRV COMPRESSOR AND MOTOR WEIGHTS\*— STANDARD AND HIGH-EFFICIENCY MOTORS (CONT) COMPRESSOR FRAME SIZE 5†

MOTOR CODE	ENGLISH						SI					
	Compressor Weight** (lb)	60 Hz		50 Hz		End Bell Cover Weight (lb)	Compressor Weight** (kg)	60 Hz		50 Hz		End Bell Cover Weight (kg)
		Stator Weight†† (lb)	Rotor Weight (lb)	Stator Weight†† (lb)	Rotor Weight (lb)			Stator Weight†† (kg)	Rotor Weight (kg)	Stator Weight†† (kg)	Rotor Weight (kg)	
<b>STANDARD-EFFICIENCY MOTORS / LOW VOLTAGE (200-575 V)</b>												
EHS	7285	2700	651	2770	701	414	3304	1225	295	1256	318	188
EJS	7285	2760	670	2890	701	414	3304	1252	304	1311	318	188
EKS	7285	2760	670	2890	718	414	3304	1252	304	1311	326	188
ELS	7285	2800	685	2960	751	414	3304	1270	311	1343	341	188
EMS	7285	2800	685	2960	751	414	3304	1270	311	1343	341	188
ENS	7285	2960	751	3110	801	414	3304	1343	341	1411	363	188
EPS	7285	2960	780	3110	801	414	3304	1343	354	1411	363	188
EQS	7285	3110	801	—	—	414	3304	1411	363	—	—	188
<b>STANDARD-EFFICIENCY MOTORS / MEDIUM VOLTAGE (2400-4160 V)</b>												
EHS	7285	2744	706	2818	741	414	3304	1245	320	1278	336	188
EJS	7285	2816	741	2892	775	414	3304	1277	336	1312	352	188
EKS	7285	2816	741	2930	775	414	3304	1277	336	1329	352	188
ELS	7285	2808	741	3005	810	414	3304	1274	336	1363	367	188
EMS	7285	2892	775	3005	810	414	3304	1322	352	1363	367	188
ENS	7285	2997	775	3143	879	414	3304	1359	352	1426	399	188
EPS	7285	2967	810	3144	879	414	3304	1346	367	1426	399	188
EQS	7285	3081	872	—	—	414	3304	1398	396	—	—	188
<b>STANDARD-EFFICIENCY MOTORS / MEDIUM VOLTAGE (6300-6900 V)</b>												
EHS	7285	2773	735	2845	769	414	3304	1258	333	1290	349	188
EJS	7285	2855	769	2855	769	414	3304	1295	349	1295	349	188
EKS	7285	2919	803	2919	803	414	3304	1324	364	1324	364	188
ELS	7285	2908	803	3058	871	414	3304	1319	364	1387	395	188
EMS	7285	3029	854	3068	871	414	3304	1374	387	1392	395	188
ENS	7285	3023	854	3281	974	414	3304	1371	387	1488	442	188
EPS	7285	3068	871	3288	974	414	3304	1392	395	1491	442	188
<b>HIGH-EFFICIENCY MOTORS / LOW VOLTAGE (200-575 V)</b>												
EHH	7285	3060	701	3120	751	414	3304	1388	318	1415	341	188
EJH	7285	3105	716	3250	751	414	3304	1408	325	1474	341	188
EKH	7285	3180	716	3250	768	414	3304	1442	325	1474	348	188
ELH	7285	3180	737	3370	801	414	3304	1442	334	1529	363	188
EMH	7285	3270	737	3370	801	414	3304	1483	334	1529	363	188
ENH	7285	3270	801	3520	851	414	3304	1483	363	1597	386	188
EPH	7285	3340	830	3520	851	414	3304	1515	376	1597	386	188
EQH	7285	3520	851	—	—	414	3304	1597	386	—	—	188

\* Total compressor weight is the sum of the compressor aerodynamic components (compressor weight column), stator, rotor, and end bell cover weights.

† See Model Number Nomenclature on page 8.

\*\* Compressor aerodynamic component weight only, motor weight not included. Applicable to standard compressors only. For high lift compressors, contact Carrier Chiller Marketing for weights.

†† Stator weight includes the stator and shell.

**19XR,XRV COMPRESSOR AND MOTOR WEIGHTS\*—  
STANDARD AND HIGH-EFFICIENCY MOTORS (CONT)  
COMPRESSOR FRAME SIZE 5† (CONT)**

MOTOR CODE	ENGLISH						SI					
	Compressor Weight** (lb)	60 Hz		50 Hz		End Bell Cover Weight (lb)	Compressor Weight** (kg)	60 Hz		50 Hz		End Bell Cover Weight (kg)
		Stator Weight†† (lb)	Rotor Weight (lb)	Stator Weight†† (lb)	Rotor Weight (lb)			Stator Weight†† (kg)	Rotor Weight (kg)	Stator Weight†† (kg)	Rotor Weight (kg)	
<b>HIGH-EFFICIENCY MOTORS / LOW VOLTAGE (200-575 V)</b>												
MBH	7285	2795	645	2856	665	414	3304	1268	293	1295	302	188
MCH	7285	2873	672	2925	693	414	3304	1303	305	1327	314	188
MDH	7285	2906	684	3013	724	414	3304	1318	310	1367	328	188
MEH	7285	2956	704	3071	737	414	3304	1341	319	1392	334	188
MFH	7285	3034	724	3153	791	414	3304	1376	328	1430	359	188
MGH	7285	3071	737	—	—	414	3304	1393	334	—	—	188
<b>HIGH-EFFICIENCY MOTORS / MEDIUM VOLTAGE (2400-4160 V)</b>												
EHH	7285	2939	776	2997	810	414	3304	1333	352	1359	367	188
EJH	7285	2999	810	3108	862	414	3304	1360	367	1410	391	188
EKH	7285	2988	810	3102	862	414	3304	1355	367	1407	391	188
ELH	7285	2981	810	3065	872	414	3304	1352	367	1390	396	188
EMH	7285	3031	855	3077	872	414	3304	1375	388	1396	396	188
ENH	7285	3075	872	3260	974	414	3304	1395	396	1479	442	188
EPH	7285	3081	872	3298	974	414	3304	1398	396	1496	442	188
<b>HIGH-EFFICIENCY MOTORS / MEDIUM VOLTAGE (6300-6900 V)</b>												
EHH	7285	2998	810	3097	862	414	3304	1360	367	1405	391	188
EJH	7285	3029	855	3100	862	414	3304	1374	388	1406	391	188
EKH	7285	3049	855	3064	872	414	3304	1383	388	1390	396	188
ELH	7285	3068	872	3060	872	414	3304	1390	396	1388	396	188
EMH	7285	—	—	3072	872	414	3304	—	—	1393	396	188
ENH	7285	3075	872	3260	974	414	3304	1395	396	1479	442	188
EPH	7285	3081	872	3288	974	414	3304	1398	396	1491	442	188
<b>HIGH-EFFICIENCY MOTORS / HIGH VOLTAGE (10000-11000 V)</b>												
MCH	7285	—	—	3956	678	414	3304	—	—	1794	308	188
MDH	7285	—	—	3956	678	414	3304	—	—	1794	308	188
MFH	7285	—	—	4062	719	414	3304	—	—	1842	326	188
MGH	7285	3820	657	—	—	414	3304	1733	298	—	—	188
MHH	7285	3820	657	—	—	414	3304	1733	298	—	—	188
<b>HIGH-EFFICIENCY MOTORS / HIGH VOLTAGE (13800 V)</b>												
MHH	7285	3779	646	—	—	414	3304	1714	293	—	—	188

\* Total compressor weight is the sum of the compressor aerodynamic components (compressor weight column), stator, rotor, and end bell cover weights.

† See Model Number Nomenclature on page 8.

\*\* Compressor aerodynamic component weight only, motor weight not included. Applicable to standard compressors only. For high lift compressors, contact Carrier Chiller Marketing for weights.

†† Stator weight includes the stator and shell.

# Physical data (cont)



## 19XR,XRV COMPRESSOR AND MOTOR WEIGHTS\*— STANDARD AND HIGH-EFFICIENCY MOTORS (CONT) COMPRESSOR FRAME SIZE E†

MOTOR CODE	ENGLISH						SI					
	Compressor Weight** (lb)	60 Hz		50 Hz		End Bell Cover Weight (lb)	Compressor Weight** (kg)	60 Hz		50 Hz		End Bell Cover Weight (kg)
		Stator Weight†† (lb)	Rotor Weight (lb)	Stator Weight†† (lb)	Rotor Weight (lb)			Stator Weight†† (kg)	Rotor Weight (kg)	Stator Weight†† (kg)	Rotor Weight (kg)	
<b>STANDARD-EFFICIENCY MOTORS / LOW VOLTAGE (380-575 V)</b>												
6H	4853	2843	741	2943	775	414	2201	1290	336	1335	352	188
6J	4853	2826	741	2943	775	414	2201	1281	336	1335	352	188
6K	4853	2943	775	2997	810	414	2201	1335	352	1359	367	188
6L	4853	2932	775	2997	810	414	2201	1330	352	1359	367	188
6M	4853	2986	810	3096	862	414	2201	1354	367	1404	391	188
6N	4853	2986	810	3203	914	414	2201	1354	367	1453	415	188
6P	4853	2986	810	3203	914	414	2201	1354	367	1453	415	188
<b>STANDARD-EFFICIENCY MOTORS / MEDIUM VOLTAGE (2400-4160 V)</b>												
6H	4853	2744	706	2818	741	414	2201	1245	320	1278	336	188
6J	4853	2816	741	2892	775	414	2201	1277	336	1312	352	188
6K	4853	2816	741	2930	775	414	2201	1277	336	1329	352	188
6L	4853	2808	741	3005	810	414	2201	1274	336	1363	367	188
6M	4853	2892	775	3005	810	414	2201	1322	352	1363	367	188
6N	4853	2997	775	3143	879	414	2201	1359	352	1426	399	188
6P	4853	2967	810	3144	879	414	2201	1346	367	1426	399	188
6Q	4853	3081	872	—	—	414	2201	1398	396	—	—	188
<b>HIGH-EFFICIENCY MOTORS / LOW VOLTAGE (380-460 V)</b>												
EH	4853	2939	776	2995	810	414	2201	1333	352	1359	367	188
EJ	4853	2944	776	3002	810	414	2201	1335	352	1362	367	188
EK	4853	2992	810	3110	862	414	2201	1357	367	1411	391	188
EL	4853	2299	810	3099	862	414	2201	1043	367	1406	391	188
EM	4853	2965	810	3210	914	414	2201	1345	367	1456	415	188
EN	4853	3015	855	3293	974	414	2201	1368	388	1494	442	188
EP	4853	3029	855	3289	974	414	2201	1374	388	1492	442	188

\* Total compressor weight is the sum of the compressor aerodynamic components (compressor weight column), stator, rotor, and end bell cover weights.

† See Model Number Nomenclature on page 8.

\*\* Compressor aerodynamic component weight only, motor weight not included. Applicable to standard compressors only. For high lift compressors, contact Carrier Chiller Marketing for weights.

†† Stator weight includes the stator and shell.

**19XR,XRV COMPRESSOR AND MOTOR WEIGHTS\*—  
STANDARD AND HIGH-EFFICIENCY MOTORS (CONT)  
COMPRESSOR FRAME SIZE E† (CONT)**

MOTOR CODE	ENGLISH						SI					
	Compressor Weight** (lb)	60 Hz		50 Hz		End Bell Cover Weight (lb)	Compressor Weight** (lb)	60 Hz		50 Hz		End Bell Cover Weight (lb)
		Stator Weight†† (lb)	Rotor Weight (kg)	Stator Weight†† (lb)	Rotor Weight (kg)			Stator Weight†† (lb)	Rotor Weight (kg)	Stator Weight†† (lb)	Rotor Weight (kg)	
<b>HIGH-EFFICIENCY MOTORS / LOW VOLTAGE (400-460 V)</b>												
MB	4853	2795	645	2856	665	414	2201	1268	293	1295	302	188
MC	4853	2873	672	2925	693	414	2201	1303	305	1327	314	188
MD	4853	2906	684	3013	724	414	2201	1318	310	1367	328	188
ME	4853	2956	704	3071	737	414	2201	1341	319	1392	334	188
MF	4853	3034	724	3153	791	414	2201	1376	328	1430	359	188
MG	4853	3071	737	—	—	414	2201	1393	334	—	—	188
<b>HIGH-EFFICIENCY MOTORS / MEDIUM VOLTAGE (2400-4160 V)</b>												
EH	4853	2939	776	2997	810	414	2201	1333	352	1359	367	188
EJ	4853	2999	810	3108	862	414	2201	1360	367	1410	391	188
EK	4853	2988	810	3102	862	414	2201	1355	367	1407	391	188
EL	4853	2981	810	3065	872	414	2201	1352	367	1390	396	188
EM	4853	3031	855	3077	872	414	2201	1375	388	1396	396	188
EN	4853	3075	872	3260	974	414	2201	1395	396	1479	442	188
EP	4853	3081	872	3298	974	414	2201	1398	396	1496	442	188
<b>HIGH-EFFICIENCY MOTORS / MEDIUM VOLTAGE (6300-6900 V)</b>												
EH	4853	2998	810	3097	862	414	2201	1360	367	1405	391	188
EJ	4853	3029	855	3100	862	414	2201	1374	388	1406	391	188
EK	4853	3049	855	3064	872	414	2201	1383	388	1390	396	188
EL	4853	3068	872	3060	872	414	2201	1390	396	1388	396	188
EM	4853	—	—	3072	872	414	2201	—	—	1393	396	188
EN	4853	3075	872	3260	974	414	2201	1395	396	1479	442	188
EP	4853	3081	872	3288	974	414	2201	1398	396	1491	442	188
<b>HIGH-EFFICIENCY MOTORS / HIGH VOLTAGE (10000-11000 V)</b>												
MD	4853	—	—	3956	678	414	2201	—	—	1794	308	188
MF	4853	—	—	4062	719	414	2201	—	—	1842	326	188
MH	4853	3820	657	—	—	414	2201	1733	298	—	—	188
<b>HIGH-EFFICIENCY MOTORS / HIGH VOLTAGE (13800 V)</b>												
MH	4853	3779	646	—	—	414	2201	1714	293	—	—	188

\* Total compressor weight is the sum of the compressor aerodynamic components (compressor weight column), stator, rotor, and end bell cover weights.

\*\* Compressor aerodynamic component weight only, motor weight not included. Applicable to standard compressors only. For high lift compressors, contact Carrier Chiller Marketing for weights.

† See Model Number Nomenclature on page 8.

†† Stator weight includes the stator and shell.



## 19XR COMPRESSOR AND MOTOR WEIGHTS\*— HIGH-EFFICIENCY MOTORS COMPRESSOR FRAME SIZE 6, 60 HZ†

MOTOR CODE	ENGLISH				SI			
	Compressor Weight** (lb)	Stator and Housing Weight (lb)	Rotor and Shaft Weight (lb)	End Bell Cover Weight (lb)	Compressor Weight** (kg)	Stator and Housing Weight (kg)	Rotor and Shaft Weight (kg)	End Bell Cover Weight (kg)
<b>VOLTAGE: 380-3-60</b>								
N	10,287	5916	1151	1021	4666	2689	523	463
P	10,287	5916	1151	1021	4666	2689	523	463
Q	10,287	6094	1177	1021	4666	2770	535	463
R	10,287	6096	1177	1021	4666	2771	535	463
S	10,287	6131	1186	1021	4666	2787	539	463
T	10,287	6138	1186	1021	4666	2790	539	463
<b>VOLTAGE: 460-3-60</b>								
N	10,287	5933	1151	1021	4666	2697	523	463
P	10,287	5936	1151	1021	4666	2698	523	463
Q	10,287	6094	1177	1021	4666	2770	535	463
R	10,287	6098	1177	1021	4666	2772	535	463
S	10,287	6136	1186	1021	4666	2789	539	463
T	10,287	6140	1186	1021	4666	2791	539	463
<b>VOLTAGE: 2400-3-60</b>								
N	10,287	5929	1212	1021	4666	2689	550	463
P	10,287	6021	1230	1021	4666	2731	558	463
Q	10,287	6112	1248	1021	4666	2772	566	463
R	10,287	6190	1264	1021	4666	2808	573	463
S	10,287	6268	1280	1021	4666	2843	581	463
T	10,287	6259	1280	1021	4666	2839	581	463
<b>VOLTAGE: 3300-3-60</b>								
N	10,287	5927	1212	1021	4666	2688	550	463
P	10,287	6019	1230	1021	4666	2730	558	463
Q	10,287	6110	1248	1021	4666	2771	566	463
R	10,287	6187	1264	1021	4666	2806	573	463
S	10,287	6263	1280	1021	4666	2841	581	463
T	10,287	6277	1280	1021	4666	2847	581	463
<b>VOLTAGE: 4160-3-60</b>								
N	10,287	6103	1247	1021	4666	2768	566	463
P	10,287	6103	1248	1021	4666	2768	566	463
Q	10,287	6103	1248	1021	4666	2768	566	463
R	10,287	6185	1264	1021	4666	2805	573	463
S	10,287	6268	1280	1021	4666	2843	581	463
T	10,287	6268	1280	1021	4666	2843	581	463
<b>VOLTAGE: 6900-3-60</b>								
N	10,287	6558	1316	1021	4666	2975	600	463
P	10,287	6559	1316	1021	4666	2975	600	463
Q	10,287	6559	1316	1021	4666	2975	600	463
R	10,287	6566	1316	1021	4666	2978	600	463
S	10,287	6574	1316	1021	4666	2982	600	463
T	10,287	6604	1351	1021	4666	2996	613	463

**19XR COMPRESSOR AND MOTOR WEIGHTS\*— HIGH-EFFICIENCY MOTORS (CONT)  
COMPRESSOR FRAME SIZE 6, 60 HZ† (CONT)**

MOTOR CODE	ENGLISH				SI			
	Compressor Weight** (lb)	Stator and Housing Weight (lb)	Rotor and Shaft Weight (lb)	End Bell Cover Weight (lb)	Compressor Weight** (kg)	Stator and Housing Weight (kg)	Rotor and Shaft Weight (kg)	End Bell Cover Weight (kg)
<b>VOLTAGE: 11000-3-60</b>								
N	10,287	6587	1351	1021	4666	2988	613	463
P	10,287	6587	1351	1021	4666	2988	613	463
Q	10,287	6587	1351	1021	4666	2988	613	463
R	10,287	6716	1385	1021	4666	3036	628	463
S	10,287	6844	1419	1021	4666	3104	644	463
T	10,287	6844	1419	1021	4666	3104	644	463
<b>VOLTAGE: 13800-3-60</b>								
N	10,287	6554	1351	1021	4666	2973	613	463
P	10,287	6554	1351	1021	4666	2973	613	463
Q	10,287	6554	1351	1021	4666	2973	613	463
R	10,287	6709	1385	1021	4666	3043	628	463
S	10,287	6864	1419	1021	4666	3113	644	463
T	10,287	6864	1419	1021	4666	3113	644	463

\* Total compressor weight is the sum of the compressor aerodynamic components (compressor weight column), stator, rotor, and end bell cover weights.

\*\* Compressor aerodynamic component weight only, motor weight not included. Applicable to standard compressors only. For high lift compressors, contact Carrier Chiller Marketing for weights.

† See Model Number Nomenclature sizes 6 and 7 on page 9.

# Physical data (cont)



## 19XR COMPRESSOR AND MOTOR WEIGHTS\*— HIGH-EFFICIENCY MOTORS (CONT) COMPRESSOR FRAME SIZE 6, 50 HZ†

MOTOR CODE	ENGLISH				SI			
	Compressor Weight** (lb)	Stator and Housing Weight (lb)	Rotor and Shaft Weight (lb)	End Bell Cover Weight (lb)	Compressor Weight** (kg)	Stator and Housing Weight (kg)	Rotor and Shaft Weight (kg)	End Bell Cover Weight (kg)
<b>VOLTAGE: 400-3-50</b>								
N	10,287	5905	1151	1021	4666	2685	523	463
P	10,287	5907	1151	1021	4666	2769	535	463
Q	10,287	6092	1177	1021	4666	2770	535	463
R	10,287	6094	1177	1021	4666	2789	539	463
S	10,287	6136	1186	1021	4666	2790	539	463
T	10,287	6138	1186	1021	4666	2685	523	463
<b>VOLTAGE: 3000-3-50</b>								
N	10,287	5918	1212	1021	4666	2684	550	463
P	10,287	6006	1230	1021	4666	2724	558	463
Q	10,287	6094	1248	1021	4666	2764	566	463
R	10,287	6184	1264	1021	4666	2805	573	463
S	10,287	6274	1280	1021	4666	2846	581	463
T	10,287	6296	1280	1021	4666	2856	581	463
<b>VOLTAGE: 3300-3-50</b>								
N	10,287	5913	1212	1021	4666	2682	550	463
P	10,287	6007	1230	1021	4666	2725	558	463
Q	10,287	6101	1248	1021	4666	2767	566	463
R	10,287	6192	1264	1021	4666	2809	573	463
S	10,287	6283	1280	1021	4666	2850	581	463
T	10,287	6266	1280	1021	4666	2842	581	463
<b>VOLTAGE: 6300-3-50</b>								
N	10,287	6277	1280	1021	4666	2847	581	463
P	10,287	6333	1298	1021	4666	2873	589	463
Q	10,287	6389	1316	1021	4666	2898	600	463
R	10,287	6473	1316	1021	4666	2936	600	463
S	10,287	6556	1316	1021	4666	2974	600	463
T	10,287	6609	1351	1021	4666	2998	613	463
<b>VOLTAGE: 10000-3-50</b>								
N	10,287	6281	1280	1021	4666	2849	581	463
P	10,287	6281	1281	1021	4666	2849	581	463
Q	10,287	6281	1281	1021	4666	2849	581	463
R	10,287	6441	1316	1021	4666	2922	600	463
S	10,287	6600	1351	1021	4666	2994	613	463
T	10,287	6156	1351	1021	4666	2792	613	463
<b>VOLTAGE: 11000-3-50</b>								
N	10,287	6600	1351	1021	4666	2994	613	463
P	10,287	6600	1351	1021	4666	2994	613	463
Q	10,287	6600	1351	1021	4666	2994	613	463
R	10,287	6765	1385	1021	4666	3069	628	463
S	10,287	6930	1419	1021	4666	3143	644	463
T	10,287	6930	1419	1021	4666	3143	644	463

\* Total compressor weight is the sum of the compressor aerodynamic components (compressor weight column), stator, rotor, and end bell cover weights.

\*\* Compressor aerodynamic component weight only, motor weight not included. Applicable to standard compressors only. For high lift compressors, contact Carrier Chiller Marketing for weights.

† See Model Number Nomenclature sizes 6 and 7 on page 9.

**19XR COMPRESSOR AND MOTOR WEIGHTS\*— HIGH-EFFICIENCY MOTORS (CONT)  
COMPRESSOR FRAME SIZE 7, 60 HZ†**

MOTOR CODE	ENGLISH				SI			
	Compressor Weight** (lb)	Stator and Housing Weight (lb)	Rotor and Shaft Weight (lb)	End Bell Cover Weight (lb)	Compressor Weight** (kg)	Stator and Housing Weight (kg)	Rotor and Shaft Weight (kg)	End Bell Cover Weight (kg)
<b>VOLTAGE: 2400-3-60</b>								
U	16,024	6719	1443	983	7268	3048	654	446
V	16,024	6718	1443	983	7268	3047	654	446
W	16,024	6717	1443	983	7268	3047	654	446
X	16,024	6811	1460	983	7268	3089	662	446
Y	16,024	6906	1476	983	7268	3132	670	446
Z	16,024	7073	1509	983	7268	3208	684	446
<b>VOLTAGE: 3300-3-60</b>								
U	16,024	6723	1443	983	7268	3049	654	446
V	16,024	6730	1443	983	7268	3053	654	446
W	16,024	6736	1443	983	7268	3055	654	446
X	16,024	6816	1460	983	7268	3092	662	446
Y	16,024	6895	1476	983	7268	3128	670	446
Z	16,024	7055	1509	983	7268	3200	684	446
<b>VOLTAGE: 4160-3-60</b>								
U	16,024	6739	1443	983	7268	3057	654	446
V	16,024	6721	1443	983	7268	3049	654	446
W	16,024	6703	1443	983	7268	3040	654	446
X	16,024	6778	1460	983	7268	3074	662	446
Y	16,024	6853	1476	983	7268	3108	670	446
Z	16,024	7069	1509	983	7268	3206	684	446
<b>VOLTAGE: 6900-3-60</b>								
U	16,024	6730	1443	983	7268	3053	654	446
V	16,024	6909	1476	983	7268	3134	670	446
W	16,024	7088	1509	983	7268	3215	684	446
X	16,024	7076	1509	983	7268	3210	684	446
Y	16,024	7064	1509	983	7268	3204	684	446
Z	16,024	7141	1542	983	7268	3239	699	446
<b>VOLTAGE: 11000-3-60</b>								
U	16,024	7042	1509	983	7268	3194	684	446
V	16,024	7085	1526	983	7268	3214	692	446
W	16,024	7128	1542	983	7268	3233	699	446
X	16,024	7131	1542	983	7268	3235	699	446
Y	16,024	7135	1542	983	7268	3236	699	446
Z	16,024	7313	1575	983	7268	3317	714	446
<b>VOLTAGE: 13800-3-60</b>								
U	16,024	7073	1509	983	7268	3208	684	446
V	16,024	7109	1526	983	7268	3225	692	446
W	16,024	7146	1542	983	7268	3241	699	446
X	16,024	7146	1542	983	7268	3241	699	446
Y	16,024	7146	1542	983	7268	3241	699	446
Z	16,024	7295	1575	983	7268	3309	714	446

\* Total compressor weight is the sum of the compressor aerodynamic components (compressor weight column), stator, rotor, and end bell cover weights.

\*\* Compressor aerodynamic component weight only, motor weight not included. Applicable to standard compressors only. For high lift compressors, contact Carrier Chiller Marketing for weights.

† See Model Number Nomenclature sizes 6 and 7 on page 9.

# Physical data (cont)



## 19XR COMPRESSOR AND MOTOR WEIGHTS\*— HIGH-EFFICIENCY MOTORS (CONT) COMPRESSOR FRAME SIZE 7, 50 HZ†

MOTOR CODE	ENGLISH				SI			
	Compressor Weight** (lb)	Stator and Housing Weight (lb)	Rotor and Shaft Weight (lb)	End Bell Cover Weight (lb)	Compressor Weight** (kg)	Stator and Housing Weight (kg)	Rotor and Shaft Weight (kg)	End Bell Cover Weight (kg)
<b>VOLTAGE: 3000-3-50</b>								
U	16,024	6725	1443	983	7268	3050	654	446
V	16,024	6716	1443	983	7268	3046	654	446
W	16,024	6706	1443	983	7268	3042	654	446
X	16,024	6802	1460	983	7268	3085	662	446
Y	16,024	6899	1476	983	7268	3129	670	446
Z	16,024	7066	1509	983	7268	3205	684	446
<b>VOLTAGE: 3300-3-50</b>								
U	16,024	6743	1443	983	7268	3059	654	446
V	16,024	6739	1443	983	7268	3057	654	446
W	16,024	6734	1443	983	7268	3054	654	446
X	16,024	6826	1460	983	7268	3096	662	446
Y	16,024	6917	1476	983	7268	3137	670	446
Z	16,024	7075	1509	983	7268	3209	684	446
<b>VOLTAGE: 6300-3-50</b>								
U	16,024	6743	1443	983	7268	3059	654	446
V	16,024	6900	1476	983	7268	3130	670	446
W	16,024	7058	1509	983	7268	3201	684	446
X	16,024	7130	1526	983	7268	3234	692	446
Y	16,024	7203	1542	983	7268	3267	699	446
Z	16,024	7203	1542	983	7268	3267	699	446
<b>VOLTAGE: 10000-3-50</b>								
U	16,024	6904	1476	983	7268	3132	670	446
V	16,024	6907	1476	983	7268	3133	670	446
W	16,024	6910	1476	983	7268	3134	670	446
X	16,024	7074	1509	983	7268	3209	684	446
Y	16,024	7238	1542	983	7268	3283	699	446
Z	16,024	7401	1575	983	7268	3357	714	446
<b>VOLTAGE: 11000-3-50</b>								
U	16,024	7139	1509	983	7268	3238	684	446
V	16,024	7186	1526	983	7268	3260	692	446
W	16,024	7234	1542	983	7268	3281	699	446
X	16,024	7234	1542	983	7268	3281	699	446
Y	16,024	7234	1542	983	7268	3281	699	446
Z	16,024	7383	1575	983	7268	3349	714	446

\* Total compressor weight is the sum of the compressor aerodynamic components (compressor weight column), stator, rotor, and end bell cover weights.

\*\* Compressor aerodynamic component weight only, motor weight not included. Applicable to standard compressors only. For high lift compressors, contact Carrier Chiller Marketing for weights.

† See Model Number Nomenclature sizes 6 and 7 on page 9.



**COMPONENT WEIGHTS — SINGLE-STAGE COMPRESSORS AND TWO-STAGE COMPRESSORS FRAME 6, FRAME 7, AND FRAME E**

COMPONENT	COMPRESSOR*													
	FRAME 2		FRAME 3		FRAME 4		FRAME 5		FRAME E		FRAME 6		FRAME 7	
	LB	KG	LB	KG	LB	KG	LB	KG	LB	KG	LB	KG	LB	KG
SUCTION PIPE ASSEMBLY (INCLUDES FLANGES)	116	53	185	84	239	108	407	185	310	141	486	220	613	278
DISCHARGE ASSEMBLY	100	45	125	57	157	71	325	147	290	132	256	116	312	142
CONTROL PANEL† (FRAMES 2-5, E)	34	15	34	15	34	15	34	15	34	15	—	—	—	—
OPTIONAL COOLER INLET ISOLATION VALVE	8	4	13	6	20	9	24	11	24	11	26	12	28	13
OPTIONAL DISCHARGE ISOLATION VALVE	26	12	46	21	74	34	108	49	93	42	277	91	324	147
STD TIER VFD — 380, 400, AND 460-V (230, 335, 445 A)	650	295	650	295	—	—	—	—	—	—	—	—	—	—
STD TIER VFD — 380, 400, AND 460-V (485, 550 A)	—	—	1035	469	1035	469	—	—	—	—	—	—	—	—
STD TIER VFD — 380, 400, AND 460-V (605, 680 A)	—	—	1600	726	1600	726	—	—	—	—	—	—	—	—
STD TIER VFD — 380, 400, AND 460-V (765 A)	—	—	—	—	1600	726	—	—	—	—	—	—	—	—
STD TIER VFD — 380, 400, AND 460-V (855, 960, 1070 A)	—	—	—	—	1600	726	1600	726	1600	726	—	—	—	—
STD TIER VFD — 380, 400, AND 460-V (1275 A)	—	—	—	—	3000	1361	3000	1361	3000	1361	—	—	—	—
STD TIER VFD — 380, 400, AND 460-V (1530 A)	—	—	—	—	—	—	3000	1361	3000	1361	—	—	—	—
LIQUIFLO™ 2 VFD — 380, 400, AND 460-V (442 A)	1600	726	1600	726	—	—	—	—	—	—	—	—	—	—
LIQUIFLO 2 VFD — 380, 400, AND 460-V (608 A)	—	—	1600	726	1600	726	—	—	—	—	—	—	—	—
LIQUIFLO 2 VFD — 380, 400, AND 460-V (900 A)	—	—	—	—	2800	1270	2800	1270	2800	1270	—	—	—	—
LIQUIFLO 2 VFD — 380, 400, AND 460-V (1200 A)	—	—	—	—	2850	1293	2850	1293	2850	1293	—	—	—	—
LIQUIFLO 2 VFD — 575-V (390 A)	2200	998	2200	998	—	—	—	—	—	—	—	—	—	—
VFD SHELF	—	—	—	—	1049	476	1049	476	1049	476	—	—	—	—
HMI PANEL (FRAMES 6 AND 7 ONLY)	—	—	—	—	—	—	—	—	—	—	25	11	25	11
AUXILIARY CONTROL PANEL (FRAMES 6 AND 7 ONLY)	—	—	—	—	—	—	—	—	—	—	190	86	190	86
ECONOMIZER COVER	—	—	—	—	—	—	—	—	120	54	132	60	182	83
HIGH SIDE FLOAT CHAMBER COVER	—	—	—	—	—	—	—	—	296	134	132	60	182	83

\* To determine compressor frame size, refer to 19XR,XRV Computer Selection Program.

† Included in total cooler weight.

NOTE: VFD sizes are available on select heat exchanger models; consult the 19XR,XRV Computer Selection program.

# Physical data (cont)



## 19XR,XRV HEAT EXCHANGER WEIGHTS — SINGLE-STAGE COMPRESSOR AND TWO-STAGE COMPRESSOR FRAME SIZE E — DRIVE END ENTERING COOLER WATER

CODE †	ENGLISH						SI					
	Dry Rigging Weight (lb) *		Machine Charge				Dry Rigging Weight (kg) *		Machine Charge			
	Cooler Only	Condenser Only	Refrigerant Weight (lb)		Water Weight (lb)		Cooler Only	Condenser Only	Refrigerant Weight (kg)		Water Weight (kg)	
			Cooler	Condenser	Cooler	Condenser			Cooler	Condenser	Cooler	Condenser
10	2707	2704	328	226	283	348	1229	1228	149	103	128	158
11	2777	2772	357	226	309	374	1261	1258	162	103	140	170
12	2848	2857	387	226	335	407	1293	1297	176	103	152	185
15	2968	2984	405	275	327	402	1346	1355	184	125	148	183
16	3054	3068	441	275	359	435	1387	1393	200	125	163	197
17	3141	3173	477	275	391	475	1426	1441	217	125	178	216
20	3407	3373	416	252	402	398	1547	1531	189	114	183	181
21	3555	3540	459	252	456	462	1614	1607	208	114	207	210
22	3711	3704	505	252	514	526	1685	1682	229	114	233	239
30	4071	3694	510	308	464	464	1848	1677	232	140	211	211
31	4253	3899	565	308	531	543	1931	1770	257	140	241	247
32	4445	4100	626	308	601	621	2018	1861	284	140	273	282
35	4343	4606	577	349	511	513	1972	2091	262	158	232	233
36	4551	4840	639	349	587	603	2066	2197	290	158	266	274
37	4769	5069	709	349	667	692	2165	2301	322	158	303	314
40	4908	5039	726	338	863	915	2228	2288	330	153	392	415
41	5078	5232	783	338	930	995	2305	2375	355	153	422	452
42	5226	5424	840	338	990	1074	2373	2462	381	153	449	488
45	5363	5602	821	383	938	998	2435	2543	373	174	426	453
46	5559	5824	874	383	1014	1088	2524	2644	397	174	460	494
47	5730	6044	949	383	1083	1179	2601	2744	431	174	492	535
50	5713	6090	897	446	1101	1225	2594	2765	407	202	500	556
51	5940	6283	974	446	1192	1304	2697	2852	442	202	541	592
52	6083	6464	1021	446	1248	1379	2762	2935	464	202	567	626
53	6141	6529	1010	446	1277	1409	2788	2964	459	202	580	640
54	6192	6591	987	446	1302	1439	2811	2992	448	202	591	653
55	6257	6785	1014	504	1201	1339	2841	3080	460	229	545	608
56	6517	7007	1101	504	1304	1429	2959	3181	500	229	592	649
57	6682	7215	1154	504	1369	1514	3034	3276	524	229	622	687
58	6751	7291	1143	504	1401	1550	3065	3310	519	229	636	704
59	6811	7363	1116	504	1430	1583	3092	3343	507	229	649	719
5A	5124	—	491	—	1023	—	2326	—	223	—	464	—
5B	5177	—	510	—	1050	—	2350	—	232	—	477	—
5C	5243	—	532	—	1079	—	2380	—	242	—	490	—
5F	5577	—	553	—	1113	—	2532	—	251	—	505	—
5G	5640	—	575	—	1143	—	2561	—	261	—	519	—
5H	5716	—	600	—	1176	—	2595	—	272	—	534	—
5K	4993	—	673	—	1067	—	2267	—	306	—	484	—
5L	5090	—	706	—	1118	—	2311	—	321	—	508	—
5M	5165	—	742	—	1162	—	2345	—	337	—	528	—
5P	5041	—	641	—	1111	—	2289	—	291	—	504	—
5Q	5131	—	678	—	1155	—	2329	—	308	—	524	—
5R	5214	—	709	—	1206	—	2367	—	322	—	548	—
5T	5425	—	768	—	1162	—	2463	—	349	—	528	—
5U	5534	—	801	—	1220	—	2512	—	364	—	554	—
5V	5620	—	843	—	1270	—	2551	—	383	—	577	—
5X	5484	—	730	—	1212	—	2490	—	331	—	550	—
5Y	5584	—	769	—	1262	—	2535	—	349	—	573	—
5Z	5678	—	805	—	1320	—	2578	—	365	—	599	—
60	6719	6764	1091	479	1400	1521	3050	3071	495	217	636	691
61	6895	6949	1150	479	1470	1597	3130	3155	522	217	667	725
62	7038	7130	1202	479	1527	1671	3195	3237	546	217	693	759
63	7103	7199	1202	479	1559	1704	3225	3268	546	217	708	774
64	7161	7264	1178	479	1587	1735	3251	3298	535	217	720	788
65	7392	6782	1241	542	1530	1667	3356	3079	563	246	695	757
66	7594	7894	1309	542	1610	1753	3448	3584	594	246	731	796
67	7759	8102	1369	542	1674	1838	3523	3678	622	246	760	834
68	7836	8182	1359	542	1711	1875	3558	3715	617	246	777	851
69	7905	8258	1332	542	1743	1911	3589	3749	605	246	791	868

\* Rigging weights are for standard tubes of standard wall thickness (0.025-in. [0.635-mm] wall).

† Heat exchanger frame sizes 1 through 6 available on single-stage chillers only.

NOTES:

1. Cooler includes the control panel (ICVC), suction elbow, and 1/2 the distribution piping weight.

2. Condenser includes float valve and sump, discharge elbow, and 1/2 the distribution piping weight.
3. For special tubes refer to the 19XR,XRV Computer Selection Program.
4. All weights for standard 2-pass NIH (nozzle-in-head) design.
5. For "E" compressor, add 1054 lb (478 kg) steel weight and 283 lb (128 kg) refrigerant weight for economizer assembly.

**19XR,XRV HEAT EXCHANGER WEIGHTS — SINGLE-STAGE COMPRESSOR AND TWO-STAGE COMPRESSOR  
FRAME SIZE E — DRIVE END ENTERING COOLER WATER (CONT)**

CODE†	ENGLISH						SI					
	Dry Rigging Weight (lb)*		Machine Charge				Dry Rigging Weight (kg)*		Machine Charge			
	Cooler Only	Condenser Only	Refrigerant Weight (lb)		Water Weight (lb)		Cooler Only	Condenser Only	Refrigerant Weight (kg)		Water Weight (kg)	
			Cooler	Condenser	Cooler	Condenser			Cooler	Condenser	Cooler	Condenser
6K	5,716	—	760	—	1291	—	2595	—	345	—	586	—
6L	5,804	—	797	—	1341	—	2635	—	362	—	609	—
6M	5,894	—	828	—	1399	—	2676	—	376	—	635	—
6P	5,768	—	725	—	1338	—	2619	—	329	—	607	—
6Q	5,852	—	764	—	1385	—	2657	—	347	—	629	—
6R	5,938	—	798	—	1439	—	2696	—	362	—	653	—
6T	6,230	—	863	—	1405	—	2828	—	392	—	638	—
6U	6,330	—	905	—	1462	—	2874	—	411	—	664	—
6V	6,433	—	941	—	1528	—	2921	—	427	—	694	—
6X	6,293	—	823	—	1459	—	2857	—	374	—	662	—
6Y	6,388	—	868	—	1512	—	2900	—	394	—	686	—
6Z	6,487	—	906	—	1574	—	2945	—	411	—	715	—
70	9,942	10,786	1409	840	2008	2225	4514	4897	640	381	912	1010
71	10,330	11,211	1539	840	2164	2389	4690	5090	699	381	982	1085
72	10,632	11,622	1646	840	2286	2548	4827	5276	747	381	1038	1157
73	10,715	11,737	1622	840	2328	2604	4865	5329	736	381	1057	1182
74	10,790	11,775	1584	840	2366	2622	4899	5346	719	381	1074	1190
75	10,840	11,859	1599	950	2183	2431	4921	5384	726	431	991	1104
76	11,289	12,345	1747	950	2361	2619	5125	5605	793	431	1072	1189
77	11,638	12,814	1869	950	2501	2801	5284	5818	849	431	1135	1272
78	11,738	12,949	1849	950	2548	2864	5329	5879	839	431	1157	1300
79	11,828	12,994	1806	950	2592	2885	5370	5899	820	431	1177	1310
7K	8,728	—	1047	—	1948	—	3963	—	475	—	884	—
7L	8,959	—	1132	—	2094	—	4067	—	514	—	951	—
7M	9,161	—	1214	—	2229	—	4159	—	551	—	1012	—
7P	8,792	—	1002	—	2010	—	3992	—	455	—	913	—
7Q	9,023	—	1087	—	2156	—	4096	—	493	—	979	—
7R	9,229	—	1167	—	2295	—	4190	—	530	—	1042	—
7T	9,431	—	1194	—	2115	—	4282	—	542	—	960	—
7U	9,698	—	1292	—	2282	—	4403	—	587	—	1036	—
7V	9,932	—	1403	—	2436	—	4509	—	637	—	1106	—
7X	9,510	—	1142	—	2185	—	4318	—	518	—	992	—
7Y	9,777	—	1240	—	2352	—	4439	—	563	—	1068	—
7Z	10,016	—	1347	—	2511	—	4547	—	612	—	1140	—
80	12,664	12,753	1700	836	2726	2977	5749	5790	772	380	1238	1352
81	12,998	13,149	1812	836	2863	3143	5901	5970	823	380	1300	1427
82	13,347	13,545	1928	836	3005	3309	6060	6149	875	380	1364	1502
83	13,437	13,872	1877	836	3053	3476	6100	6298	852	380	1386	1578
84	13,523	14,217	1840	836	3099	3651	6139	6455	835	380	1407	1658
85	13,804	14,008	1927	945	2951	3238	6267	6360	875	429	1340	1470
86	14,191	14,465	2054	945	3108	3428	6443	6567	933	429	1411	1556
87	14,597	14,923	2186	945	3271	3618	6627	6775	992	429	1485	1643
88	14,705	15,311	2142	945	3325	3608	6676	6951	972	429	1510	1638
89	14,808	15,721	2099	945	3378	4009	6723	7137	953	429	1534	1820
8K	11,153	—	1385	—	2760	—	5063	—	629	—	1253	—
8L	11,400	—	1484	—	2926	—	5176	—	674	—	1328	—
8M	11,650	—	1589	—	3088	—	5289	—	721	—	1402	—
8P	11,219	—	1334	—	2830	—	5093	—	606	—	1285	—
8Q	11,470	—	1430	—	2999	—	5207	—	649	—	1362	—
8R	11,719	—	1535	—	3161	—	5320	—	697	—	1435	—
8T	12,069	—	1580	—	2991	—	5479	—	717	—	1358	—
8U	12,357	—	1694	—	3180	—	5610	—	769	—	1444	—
8V	12,645	—	1814	—	3365	—	5741	—	824	—	1528	—
8X	12,152	—	1522	—	3070	—	5517	—	691	—	1394	—
8Y	12,444	—	1632	—	3264	—	5650	—	741	—	1482	—
8Z	12,733	—	1752	—	3448	—	5781	—	795	—	1565	—

\* Rigging weights are for standard tubes of standard wall thickness (0.025-in. [0.635-mm] wall).  
† Heat exchanger frame sizes 1 through 6 available on single-stage chillers only.

**NOTES:**

1. Cooler includes the control panel (ICVC), suction elbow, and 1/2 the distribution piping weight.

2. Condenser includes float valve and sump, discharge elbow, and 1/2 the distribution piping weight.  
3. For special tubes refer to the 19XR,XRV Computer Selection Program.  
4. All weights for standard 2-pass NIH (nozzle-in-head) design.  
5. For "E" compressor, add 1054 lb (478 kg) steel weight and 283 lb (128 kg) refrigerant weight for economizer assembly.

# Physical data (cont)



## 19XR,XRV HEAT EXCHANGER WEIGHTS — SINGLE-STAGE COMPRESSOR AND TWO-STAGE COMPRESSOR FRAME SIZE E — COMPRESSOR END ENTERING COOLER WATER

CODE†	ENGLISH						SI					
	Dry Rigging Weight (lb)*		Machine Charge				Dry Rigging Weight (kg)*		Machine Charge			
	Cooler Only	Condenser Only	Refrigerant Weight (lb)		Water Weight (lb)		Cooler Only	Condenser Only	Refrigerant Weight (kg)		Water Weight (kg)	
			Cooler	Condenser	Cooler	Condenser			Cooler	Condenser	Cooler	Condenser
10	2707	2704	290	200	283	348	1228	1227	132	91	128	158
11	2777	2772	310	200	309	374	1260	1257	141	91	140	170
12	2848	2857	330	200	335	407	1292	1296	150	91	152	185
15	2968	2984	320	250	327	402	1346	1354	145	113	148	182
16	3054	3068	340	250	359	435	1385	1392	154	113	163	197
17	3141	3173	370	250	391	475	1425	1439	168	113	177	215
20	3407	3373	345	225	402	398	1545	1530	156	102	182	181
21	3555	3540	385	225	456	462	1613	1606	175	102	207	210
22	3711	3704	435	225	514	526	1683	1680	197	102	233	239
30	4071	3694	350	260	464	464	1847	1676	159	118	210	210
31	4253	3899	420	260	531	543	1929	1769	191	118	241	246
32	4445	4100	490	260	601	621	2016	1860	222	118	273	282
35	4343	4606	400	310	511	513	1970	2089	181	141	232	233
36	4551	4840	480	310	587	603	2064	2195	218	141	266	274
37	4769	5069	550	310	667	692	2163	2299	249	141	303	314
40	4908	5039	560	338	863	915	2226	2286	254	153	391	415
41	5078	5232	630	338	930	995	2303	2373	286	153	422	451
42	5226	5424	690	338	990	1074	2370	2460	313	153	449	487
45	5363	5602	640	383	938	998	2433	2541	290	174	425	453
46	5559	5824	720	383	1014	1088	2522	2642	327	174	460	494
47	5730	6044	790	383	1083	1179	2599	2742	358	174	491	535
50	5713	6090	750	446	1101	1225	2591	2762	340	202	499	556
51	5940	6283	840	446	1192	1304	2694	2850	381	202	541	591
52	6083	6464	900	446	1248	1379	2759	2932	408	202	566	626
53	6141	6529	900	446	1277	1409	2788	2964	408	202	580	640
54	6192	6591	900	446	1302	1439	2811	2992	408	202	591	653
55	6257	6785	870	509	1201	1339	2838	3078	395	231	545	607
56	6517	7007	940	509	1304	1429	2956	3178	426	231	591	648
57	6682	7215	980	509	1369	1514	3031	3273	445	231	621	687
58	6751	7291	980	509	1401	1550	3065	3310	445	231	636	704
59	6811	7363	980	509	1430	1583	3092	3343	445	231	649	719
5A	5124	—	500	—	1023	—	2324	—	227	—	464	—
5B	5177	—	520	—	1050	—	2348	—	236	—	476	—
5C	5243	—	550	—	1079	—	2378	—	249	—	489	—
5F	5577	—	550	—	1113	—	2530	—	249	—	505	—
5G	5640	—	570	—	1143	—	2558	—	259	—	518	—
5H	5716	—	600	—	1176	—	2593	—	272	—	533	—
5K	4993	—	673	—	1067	—	2267	—	306	—	484	—
5L	5090	—	706	—	1118	—	2311	—	321	—	508	—
5M	5165	—	742	—	1162	—	2345	—	337	—	528	—
5P	5041	—	641	—	1111	—	2289	—	291	—	504	—
5Q	5131	—	678	—	1155	—	2329	—	308	—	524	—
5R	5214	—	709	—	1206	—	2367	—	322	—	548	—
5T	5425	—	768	—	1162	—	2463	—	349	—	528	—
5U	5534	—	801	—	1220	—	2512	—	364	—	554	—
5V	5620	—	843	—	1270	—	2551	—	383	—	577	—
5X	5484	—	730	—	1212	—	2490	—	331	—	550	—
5Y	5584	—	769	—	1262	—	2535	—	349	—	573	—
5Z	5678	—	805	—	1320	—	2578	—	365	—	599	—
60	6719	6764	940	479	1400	1521	3048	3068	426	217	635	690
61	6895	6949	980	479	1470	1597	3128	3152	445	217	667	724
62	7038	7130	1020	479	1527	1671	3192	3234	463	217	693	758
63	7103	7199	1020	479	1559	1704	3225	3268	463	217	708	773
64	7161	7264	1020	479	1587	1735	3251	3298	463	217	720	788
65	7392	7682	1020	542	1530	1667	3353	3484	463	246	694	756
66	7594	7894	1060	542	1610	1753	3445	3581	481	246	730	795
67	7759	8102	1090	542	1674	1838	3519	3675	494	246	759	834
68	7836	8182	1090	542	1711	1875	3558	3715	494	246	777	851
69	7905	8258	1090	542	1743	1911	3589	3749	494	246	791	868

\* Rigging weights are for standard tubes of standard wall thickness (0.025-in. [0.635-mm] wall).

† Heat exchanger frame sizes 1 through 6 available on single-stage chillers only.

**NOTES:**

1. Cooler includes the control panel (ICVC), suction elbow, and 1/2 the distribution piping weight.

2. Condenser includes float valve and sump, discharge elbow, and 1/2 the distribution piping weight.
3. For special tubes refer to the 19XR,XRV Computer Selection Program.
4. All weights for standard 2-pass NIH (nozzle-in-head) design.
5. For "E" compressor, add 1054 lb (478 kg) steel weight and 283 lb (128 kg) refrigerant weight for economizer assembly.

**19XR,XRV HEAT EXCHANGER WEIGHTS — SINGLE-STAGE COMPRESSOR AND TWO-STAGE COMPRESSOR  
FRAME SIZE E — COMPRESSOR END ENTERING COOLER WATER (CONT)**

CODE†	ENGLISH							SI					
	Dry Rigging Weight (lb)*		Machine Charge				Dry Rigging Weight (kg)*		Machine Charge				
	Cooler Only	Condenser Only	Refrigerant Weight (lb)		Water Weight (lb)		Cooler Only	Condenser Only	Refrigerant Weight (kg)		Water Weight (kg)		
			Cooler	Condenser	Cooler	Condenser			Cooler	Condenser	Cooler	Condenser	
6K	5,716	—	760	—	1291	—	2595	—	345	—	586	—	
6L	5,804	—	797	—	1341	—	2635	—	362	—	609	—	
6M	5,894	—	828	—	1399	—	2676	—	376	—	635	—	
6P	5,768	—	725	—	1338	—	2619	—	329	—	607	—	
6Q	5,852	—	764	—	1385	—	2657	—	347	—	629	—	
6R	5,938	—	798	—	1439	—	2696	—	362	—	653	—	
6T	6,230	—	863	—	1405	—	2828	—	392	—	638	—	
6U	6,330	—	905	—	1462	—	2874	—	411	—	664	—	
6V	6,433	—	941	—	1528	—	2921	—	427	—	694	—	
6X	6,293	—	823	—	1459	—	2857	—	374	—	662	—	
6Y	6,388	—	868	—	1512	—	2900	—	394	—	686	—	
6Z	6,487	—	906	—	1574	—	2945	—	411	—	715	—	
70	9,942	10,786	1220	840	2008	2225	4510	4893	553	381	911	1009	
71	10,330	11,211	1340	840	2164	2389	4686	5085	608	381	982	1084	
72	10,632	11,622	1440	840	2286	2548	4823	5278	653	381	1037	1156	
73	10,715	11,737	1440	840	2328	2604	4865	5329	654	381	1057	1182	
74	10,790	11,775	1440	840	2366	2622	4899	5346	654	381	1074	1190	
75	10,840	11,859	1365	950	2183	2431	4917	5379	619	431	990	1103	
76	11,289	12,345	1505	950	2361	2619	5121	5600	683	431	1071	1188	
77	11,638	12,814	1625	950	2501	2801	5279	5812	737	431	1134	1271	
78	11,738	12,949	1625	950	2548	2864	5329	5879	738	431	1157	1300	
79	11,828	12,994	1625	950	2592	2885	5370	5899	738	431	1177	1310	
7K	8,728	—	1047	—	1948	—	3963	—	475	—	884	—	
7L	8,959	—	1132	—	2094	—	4067	—	514	—	951	—	
7M	9,161	—	1214	—	2229	—	4159	—	551	—	1012	—	
7P	8,792	—	1002	—	2010	—	3992	—	455	—	913	—	
7Q	9,023	—	1087	—	2156	—	4096	—	493	—	979	—	
7R	9,229	—	1167	—	2295	—	4190	—	530	—	1042	—	
7T	9,431	—	1194	—	2115	—	4282	—	542	—	960	—	
7U	9,698	—	1292	—	2282	—	4403	—	587	—	1036	—	
7V	9,932	—	1403	—	2436	—	4509	—	637	—	1106	—	
7X	9,510	—	1142	—	2185	—	4318	—	518	—	992	—	
7Y	9,777	—	1240	—	2352	—	4439	—	563	—	1068	—	
7Z	10,016	—	1347	—	2511	—	4547	—	612	—	1140	—	
80	12,664	12,753	1500	836	2726	2977	5744	5785	680	379	1236	1350	
81	12,998	13,149	1620	836	2863	3143	5896	5964	735	379	1299	1426	
82	13,347	13,545	1730	836	3005	3309	6054	6144	785	379	1363	1501	
83	13,437	13,872	1730	836	3053	3476	6100	6298	785	379	1386	1578	
84	13,523	14,217	1730	836	3099	3651	6139	6455	785	379	1407	1658	
85	13,804	14,008	1690	945	2951	3238	6261	6354	767	429	1339	1469	
86	14,191	14,465	1820	945	3108	3428	6437	6561	826	429	1410	1555	
87	14,597	14,923	1940	945	3271	3618	6621	6769	880	429	1484	1641	
88	14,705	15,311	1940	945	3325	3808	6676	6951	881	429	1510	1729	
89	14,808	15,721	1940	945	3378	4009	6723	7137	881	429	1534	1820	
8K	11,153	—	1385	—	2760	—	5063	—	629	—	1253	—	
8L	11,400	—	1484	—	2926	—	5176	—	674	—	1328	—	
8M	11,650	—	1589	—	3088	—	5289	—	721	—	1402	—	
8P	11,219	—	1334	—	2830	—	5093	—	606	—	1285	—	
8Q	11,470	—	1430	—	2999	—	5207	—	649	—	1362	—	
8R	11,719	—	1535	—	3161	—	5320	—	697	—	1435	—	
8T	12,069	—	1580	—	2991	—	5479	—	717	—	1358	—	
8U	12,357	—	1694	—	3180	—	5610	—	769	—	1444	—	
8V	12,645	—	1814	—	3365	—	5741	—	824	—	1528	—	
8X	12,152	—	1522	—	3070	—	5517	—	691	—	1394	—	
8Y	12,444	—	1632	—	3264	—	5650	—	741	—	1482	—	
8Z	12,733	—	1752	—	3448	—	5781	—	795	—	1565	—	

\* Rigging weights are for standard tubes of standard wall thickness (0.025-in. [0.635-mm] wall).  
† Heat exchanger frame sizes 1 through 6 available on single-stage chillers only.

NOTES:

- Cooler includes the control panel (ICVC), suction elbow, and 1/2 the distribution piping weight.
- Condenser includes float valve and sump, discharge elbow, and 1/2 the distribution piping weight.
- For special tubes refer to the 19XR,XRV Computer Selection Program.
- All weights for standard 2-pass NIH (nozzle-in-head) design.
- For "E" compressor, add 1054 lb (478 kg) steel weight and 283 lb (128 kg) refrigerant weight for economizer assembly.

## 19XR TWO-STAGE COMPRESSOR FRAME SIZE 6 HEAT EXCHANGER WEIGHTS (ENGLISH)

CODE†	DRY RIGGING WEIGHT (lb)*		REFRIGERANT WEIGHT (lb)		WATER WEIGHT (lb)	
	COOLER ONLY	CONDENSER ONLY	COOLER ONLY	CONDENSER ONLY	COOLER ONLY	CONDENSER ONLY
A40	16,877	18,542	1647	927	4328	4553
A41	17,270	19,062	1773	927	4557	4890
A42	17,690	19,565	1887	927	4816	5213
A45	16,968	18,493	1599	927	4453	4582
A46	17,371	19,063	1714	927	4701	4949
A47	17,761	19,578	1837	927	4941	5281
A60	18,354	20,139	1878	1074	4721	5029
A61	18,807	20,745	2022	1074	4984	5415
A62	19,295	21,330	2152	1074	5280	5786
A65	18,469	20,095	1823	1074	4859	5060
A66	18,936	20,758	1954	1074	5144	5482
A67	19,389	21,357	2095	1074	5419	5862
A4A	15,540	17,089	1681	861	4183	4524
A4B	15,794	17,472	1792	861	4392	4859
A4C	16,063	17,812	1897	861	4615	5137
A4F	15,592	17,076	1626	861	4322	4588
A4G	15,845	17,405	1736	861	4531	4867
A4H	16,249	17,821	1890	861	4865	5219
A6A	16,465	18,359	1917	998	4555	4996
A6B	16,758	18,806	2044	998	4794	5368
A6C	17,070	19,202	2164	998	5050	5698
A6F	16,535	18,356	1854	998	4709	5068
A6G	16,829	18,739	1979	998	4948	5387
A6H	17,296	19,225	2156	998	5331	6156
B40	—	21,217	—	1233	—	5850
B41	—	21,965	—	1233	—	6333
B42	—	22,581	—	1233	—	6729
B45	—	21,173	—	1233	—	5904
B46	—	21,909	—	1233	—	6379
B47	—	22,653	—	1233	—	6859
B60	—	23,061	—	1423	—	6464
B61	—	23,932	—	1423	—	7018
B62	—	24,649	—	1423	—	7473
B65	—	23,022	—	1423	—	6521
B66	—	23,879	—	1423	—	7066
B67	—	24,745	—	1423	—	7617
B4A	—	19,217	—	1148	—	5756
B4B	—	19,793	—	1148	—	6243
B4C	—	20,254	—	1148	—	6633
B4F	—	19,217	—	1148	—	5852
B4G	—	19,721	—	1148	—	6279
B4H	—	20,318	—	1148	—	6785
B6A	—	20,794	—	1326	—	6357
B6B	—	21,465	—	1326	—	6915
B6C	—	22,002	—	1326	—	7362
B6F	—	20,806	—	1326	—	6462
B6G	—	21,393	—	1326	—	6951
B6H	—	22,088	—	1326	—	8379

\* Rigging weights are for standard tubes of standard wall thickness (0.025-in. [0.635-mm] wall).

† See Model Number Nomenclature for 19XR Two-Stage Compressor Frame Size 6 and 7 on page 9.

### NOTES:

1. Cooler weight includes the suction elbow and the distribution piping to the economizer and two-pass Victaulic dished heads.
2. Condenser weight includes the high side float chamber, discharge pipe, and the distribution piping weight from the economizer to the float chamber and two-pass Victaulic dished heads.

### 19XR TWO-STAGE COMPRESSOR FRAME SIZE 6 HEAT EXCHANGER WEIGHTS (SI)

CODE†	DRY RIGGING WEIGHT (kg)*		REFRIGERANT WEIGHT (kg)		WATER WEIGHT (kg)	
	COOLER ONLY	CONDENSER ONLY	COOLER ONLY	CONDENSER ONLY	COOLER ONLY	CONDENSER ONLY
A40	7655	8 410	747	420	1963	2065
A41	7833	8 646	804	420	2067	2218
A42	8024	8 875	856	420	2184	2365
A45	7697	8 388	725	420	2020	2078
A46	7879	8 647	777	420	2132	2245
A47	8056	8 880	833	420	2241	2395
A60	8325	9 135	852	487	2141	2281
A61	8531	9 410	917	487	2261	2456
A62	8752	9 675	976	487	2395	2624
A65	8377	9 115	827	487	2204	2295
A66	8589	9 416	886	487	2333	2487
A67	8795	9 687	950	487	2458	2659
A4A	7049	7 751	762	391	1897	2052
A4B	7164	7 925	813	391	1992	2204
A4C	7286	8 079	860	391	2093	2330
A4F	7072	7 746	738	391	1960	2081
A4G	7187	7 895	787	391	2055	2208
A4H	7370	8 083	857	391	2207	2367
A6A	7468	8 328	870	453	2066	2266
A6B	7601	8 530	927	453	2175	2435
A6C	7743	8 710	982	453	2291	2585
A6F	7500	8 326	841	453	2136	2299
A6G	7633	8 500	898	453	2244	2444
A6H	7845	8 730	978	453	2418	2792
B40	—	9 624	—	559	—	2653
B41	—	9 963	—	559	—	2873
B42	—	10 243	—	559	—	3052
B45	—	9 604	—	559	—	2678
B46	—	9 938	—	559	—	2893
B47	—	10 275	—	559	—	3111
B60	—	10 460	—	645	—	2932
B61	—	10 855	—	645	—	3183
B62	—	11 181	—	645	—	3390
B65	—	10 442	—	645	—	2958
B66	—	10 831	—	645	—	3205
B67	—	11 224	—	645	—	3455
B4A	—	8 717	—	521	—	2611
B4B	—	8 978	—	521	—	2832
B4C	—	9 187	—	521	—	3009
B4F	—	8 717	—	521	—	2654
B4G	—	8 945	—	521	—	2848
B4H	—	9 216	—	521	—	3078
B6A	—	9 432	—	601	—	2883
B6B	—	9 736	—	601	—	3137
B6C	—	9 980	—	601	—	3339
B6F	—	9 487	—	601	—	2931
B6G	—	9 704	—	601	—	3153
B6H	—	10 019	—	601	—	3801

\* Rigging weights are for standard tubes of standard wall thickness (0.025-in. [0.635-mm] wall).

† See Model Number Nomenclature for 19XR Two-Stage Compressor Frame Size 6 and 7 on page 9.

**NOTES:**

1. Cooler weight includes the suction elbow and the distribution piping to the economizer and two-pass Victaulic dished heads.
2. Condenser weight includes the high side float chamber, discharge pipe, and the distribution piping weight from the economizer to the float chamber and two-pass Victaulic dished heads.



## 19XR TWO-STAGE COMPRESSOR FRAME SIZE 7 HEAT EXCHANGER WEIGHTS (ENGLISH)

CODE†	DRY RIGGING WEIGHT (lb)*		REFRIGERANT WEIGHT (lb)		WATER WEIGHT (lb)	
	COOLER ONLY	CONDENSER ONLY	COOLER ONLY	CONDENSER ONLY	COOLER ONLY	CONDENSER ONLY
B60	24,704	—	2273	—	6,340	—
B61	25,337	—	2355	—	6,737	—
B62	25,964	—	2460	—	7,116	—
B65	25,014	—	2185	—	6,485	—
B66	25,631	—	2275	—	6,873	—
B67	26,264	—	2379	—	7,255	—
B6A	22,819	—	2081	—	6,159	—
B6B	23,299	—	2162	—	6,568	—
B6C	23,829	—	2256	—	6,993	—
B6F	23,139	—	1951	—	6,344	—
B6G	23,648	—	2019	—	6,774	—
B6H	24,171	—	2120	—	7,194	—
B80	26,184	—	2557	—	6,766	—
B81	26,922	—	2649	—	7,208	—
B82	27,627	—	2768	—	7,629	—
B85	26,438	—	2458	—	6,923	—
B86	27,157	—	2559	—	7,355	—
B87	27,868	—	2676	—	7,780	—
B8A	24,164	—	2341	—	6,580	—
B8B	24,722	—	2432	—	7,036	—
B8C	25,317	—	2538	—	7,510	—
B8F	24,403	—	2195	—	6,783	—
B8G	25,011	—	2271	—	7,262	—
B8H	25,599	—	2385	—	7,731	—
C60	30,825	29,857	2647	1610	8,475	8,630
C61	31,536	30,881	2751	1610	8,924	9,275
C62	32,467	31,871	2875	1610	9,474	9,916
C65	31,135	29,982	2562	1610	8,645	8,684
C66	31,851	31,064	2666	1610	9,097	9,362
C67	32,777	32,186	2793	1610	9,644	10,078
C6A	28,641	27,676	2443	1497	6,898	8,675
C6B	29,167	28,315	2534	1497	7,352	9,216
C6C	29,750	28,918	2627	1497	7,823	9,752
C6F	28,929	27,774	2334	1497	7,724	8,710
C6G	29,478	28,457	2415	1497	8,194	9,283
C6H	30,083	29,223	2500	1497	8,681	9,935
C80	22,433	31,810	2978	1811	9,084	9,312
C81	22,315	32,955	3095	1811	9,589	10,029
C82	22,231	34,094	3234	1811	10,208	10,742
C85	22,534	31,911	2882	1811	9,275	9,367
C86	22,416	33,113	2999	1811	9,784	10,120
C87	22,332	34,385	3142	1811	10,399	10,196
C8A	22,432	19,664	2748	1684	7,310	9,387
C8B	22,314	19,548	2851	1684	7,821	9,991
C8C	22,230	19,463	2955	1684	8,351	10,589
C8F	22,533	19,763	2626	1684	8,239	9,420
C8G	22,415	19,641	2717	1684	8,768	10,059
C8H	22,331	19,503	2813	1684	9,316	10,787

\* Rigging weights are for standard tubes of standard wall thickness (0.025-in. [0.635-mm] wall).

† See Model Number Nomenclature for 19XR Two-Stage Compressor Frame Size 6 and 7 on page 9.

### NOTES:

1. Cooler weight includes the suction elbow and the distribution piping to the economizer and two-pass Victaulic dished heads.
2. Condenser weight includes the high side float chamber, discharge pipe, and the distribution piping weight from the economizer to the float chamber and two-pass Victaulic dished heads.

**19XR TWO-STAGE COMPRESSOR FRAME SIZE 7  
HEAT EXCHANGER WEIGHTS (ENGLISH) (CONT)**

CODE†	DRY RIGGING WEIGHT (lb)*		REFRIGERANT WEIGHT (lb)		WATER WEIGHT (lb)	
	COOLER ONLY	CONDENSER ONLY	COOLER ONLY	CONDENSER ONLY	COOLER ONLY	CONDENSER ONLY
D60	—	38,296	—	2097	—	11,473
D61	—	39,624	—	2097	—	12,309
D62	—	41,031	—	2097	—	13,210
D65	—	37,624	—	2097	—	11,617
D66	—	38,837	—	2097	—	12,387
D67	—	40,460	—	2097	—	13,410
D80	—	41,916	—	2359	—	12,447
D81	—	43,382	—	2359	—	13,388
D82	—	44,963	—	2359	—	14,401
D85	—	42,058	—	2359	—	12,609
D86	—	43,408	—	2359	—	13,475
D87	—	45,204	—	2359	—	14,626
D6A	—	35,286	—	1947	—	11,401
D6B	—	36,328	—	1947	—	12,255
D6C	—	37,288	—	1947	—	13,078
D6F	—	34,447	—	1947	—	11,448
D6G	—	35,637	—	1947	—	12,408
D6H	—	36,663	—	1947	—	13,278
D8A	—	38,494	—	2190	—	12,366
D8B	—	39,633	—	2190	—	13,327
D8C	—	40,731	—	2190	—	14,253
D8F	—	38,479	—	2190	—	12,419
D8G	—	39,761	—	2190	—	13,499
D8H	—	40,922	—	2190	—	14,478

\* Rigging weights are for standard tubes of standard wall thickness (0.025-in. [0.635-mm] wall).  
 † See Model Number Nomenclature for 19XR Two-Stage Compressor Frame Size 6 and 7 on page 9.

NOTES:  
 1. Cooler weight includes the suction elbow and the distribution piping to the economizer and two-pass Victaulic dished heads.  
 2. Condenser weight includes the high side float chamber, discharge pipe, and the distribution piping weight from the economizer to the float chamber and two-pass Victaulic dished heads.

## 19XR TWO-STAGE COMPRESSOR FRAME SIZE 7 HEAT EXCHANGER WEIGHTS (SI)

CODE†	DRY RIGGING WEIGHT (kg)*		REFRIGERANT WEIGHT (kg)		WATER WEIGHT (kg)	
	COOLER ONLY	CONDENSER ONLY	COOLER ONLY	CONDENSER ONLY	COOLER ONLY	CONDENSER ONLY
B60	11 206	—	1031	—	2876	—
B61	11 493	—	1068	—	3056	—
B62	11 777	—	1116	—	3228	—
B65	11 346	—	991	—	2941	—
B66	11 626	—	1032	—	3118	—
B67	11 913	—	1079	—	3291	—
B6A	10 351	—	944	—	2794	—
B6B	10 568	—	981	—	2979	—
B6C	10 809	—	1023	—	3172	—
B6F	10 496	—	885	—	2878	—
B6G	10 727	—	916	—	3073	—
B6H	10 964	—	962	—	3263	—
B80	11 877	—	1160	—	3069	—
B81	12 212	—	1202	—	3269	—
B82	12 531	—	1256	—	3460	—
B85	11 992	—	1115	—	3141	—
B86	12 318	—	1161	—	3336	—
B87	11 214	—	1214	—	3529	—
B8A	10 952	—	1062	—	2885	—
B8B	11 214	—	1103	—	3191	—
B8C	11 484	—	1151	—	3406	—
B8F	11 069	—	996	—	3077	—
B8G	11 345	—	1030	—	3294	—
B8H	11 612	—	1082	—	3507	—
C60	13 982	13 543	1201	730	3841	3914
C61	14 304	14 007	1248	730	4048	4207
C62	14 727	14 456	1304	730	4297	4498
C65	14 123	13 600	1162	730	3921	3939
C66	14 447	14 090	1209	730	4126	4247
C67	14 867	14 599	1267	730	4374	4571
C6A	12 991	12 554	1108	679	3129	3935
C6B	13 230	12 843	1149	679	3325	4180
C6C	13 494	13 117	1192	679	3553	4423
C6F	13 222	12 508	1059	679	3504	3951
C6G	13 371	12 908	1095	679	3717	4211
C6H	13 645	13 255	1134	679	3938	4506
C80	10 175	14 429	1351	821	4120	4224
C81	10 122	14 948	1404	821	4349	4549
C82	10 084	15 465	1467	821	4630	4872
C85	10 221	14 475	1307	821	4207	4249
C86	10 168	14 020	1360	821	4438	4590
C87	10 130	15 597	1425	821	4717	4625
C8A	10 175	8 919	1246	764	3316	4258
C8B	10 121	8 867	1293	764	3548	4532
C8C	10 083	8 816	1340	764	3788	4803
C8F	10 221	8 964	1191	764	3737	4273
C8G	10 167	8 909	1232	764	3977	4563
C8H	10 129	8 846	1276	764	4226	4893

\* Rigging weights are for standard tubes of standard wall thickness (0.025-in. [0.635-mm] wall).

† See Model Number Nomenclature for 19XR Two-Stage Compressor Frame Size 6 and 7 on page 9.

### NOTES:

1. Cooler weight includes the suction elbow and the distribution piping to the economizer and two-pass Victaulic dished heads.
2. Condenser weight includes the high side float chamber, discharge pipe, and the distribution piping weight from the economizer to the float chamber and two-pass Victaulic dished heads.

### 19XR TWO-STAGE COMPRESSOR FRAME SIZE 7 HEAT EXCHANGER WEIGHTS (SI) (CONT)

CODE†	DRY RIGGING WEIGHT (lb)*		REFRIGERANT WEIGHT (lb)		WATER WEIGHT (lb)	
	COOLER ONLY	CONDENSER ONLY	COOLER ONLY	CONDENSER ONLY	COOLER ONLY	CONDENSER ONLY
D60	—	17 371	—	951	—	5204
D61	—	17 973	—	951	—	5583
D62	—	18 611	—	951	—	5992
D65	—	17 066	—	951	—	5269
D66	—	17 616	—	951	—	5619
D67	—	18 352	—	951	—	6083
D80	—	19 013	—	1070	—	5646
D81	—	19 678	—	1070	—	6073
D82	—	20 395	—	1070	—	6532
D85	—	19 077	—	1070	—	5719
D86	—	19 690	—	1070	—	6112
D87	—	20 504	—	1070	—	6634
D6A	—	16 005	—	883	—	5171
D6B	—	16 478	—	883	—	5559
D6C	—	16 914	—	883	—	5932
D6F	—	15 625	—	883	—	5193
D6G	—	16 165	—	883	—	5628
D6H	—	16 630	—	883	—	6023
D8A	—	17 461	—	993	—	5609
D8B	—	17 977	—	993	—	6045
D8C	—	18 475	—	993	—	6465
D8F	—	17 454	—	993	—	5633
D8G	—	18 035	—	993	—	6123
D8H	—	18 562	—	993	—	6567

\* Rigging weights are for standard tubes of standard wall thickness (0.025-in. [0.635-mm] wall).  
 † See Model Number Nomenclature for 19XR Two-Stage Compressor Frame Size 6 and 7 on page 9.

NOTES:  
 1. Cooler weight includes the suction elbow and the distribution piping to the economizer and two-pass Victaulic dished heads.  
 2. Condenser weight includes the high side float chamber, discharge pipe, and the distribution piping weight from the economizer to the float chamber and two-pass Victaulic dished heads.

### 19XR TWO-STAGE COMPRESSOR FRAME SIZES 6 AND 7 ECONOMIZER WEIGHT

FRAME SIZE	DRY WEIGHT (lb)*	REFRIGERANT WEIGHT (lb)	OPERATION WEIGHT (LB)	DRY WEIGHT (kg)*	REFRIGERANT WEIGHT (kg)	OPERATION WEIGHT (KG)
XR6	1739	360	2099	789	163	952
XR7	2749	646	3395	1247	293	1540

\* Includes economizer weight and all the connecting piping to the compressor.

## ADDITIONAL WEIGHTS FOR 19XR,XRV MARINE WATERBOXES\* 150 PSIG (1034 KPA) MARINE WATERBOXES — SINGLE-STAGE COMPRESSORS

FRAME†	NUMBER OF PASSES	ENGLISH (LB)				SI (KG)			
		COOLER		CONDENSER		COOLER		CONDENSER	
		RIGGING WGT	WATER WGT	RIGGING WGT	WATER WGT	RIGGING WGT	WATER WGT	RIGGING WGT	WATER WGT
1	1&3	N/A	N/A	N/A	N/A	N/A	N/A	N/A	N/A
	2	N/A	N/A	N/A	N/A	N/A	N/A	N/A	N/A
2 and 3	1&3	730	700	N/A	N/A	331	318	N/A	N/A
	2	365	350	365	350	166	159	166	159
4	1&3	1888	908	N/A	N/A	856	412	N/A	N/A
	2	944	452	989	452	428	205	449	205
5	1&3	2445	1019	N/A	N/A	1109	462	N/A	N/A
	2	1223	510	1195	499	555	231	542	226
6	1&3	2860	1155	N/A	N/A	1297	524	N/A	N/A
	2	1430	578	1443	578	649	262	655	262
7	1&3	3970	2579	N/A	N/A	1801	1170	N/A	N/A
	2	1720	1290	1561	1025	780	585	708	465
8	1&3	5048	3033	N/A	N/A	2290	1376	N/A	N/A
	2	2182	1517	1751	1172	990	688	794	532

## 300 PSIG (2068 KPA) MARINE WATERBOXES — SINGLE-STAGE COMPRESSORS

FRAME†	NUMBER OF PASSES	ENGLISH (LB)				SI (KG)			
		COOLER		CONDENSER		COOLER		CONDENSER	
		RIGGING WGT	WATER WGT	RIGGING WGT	WATER WGT	RIGGING WGT	WATER WGT	RIGGING WGT	WATER WGT
1	1&3	N/A	N/A	N/A	N/A	N/A	N/A	N/A	N/A
	2	N/A	N/A	N/A	N/A	N/A	N/A	N/A	N/A
2 and 3	1&3	860	700	N/A	N/A	390	318	N/A	N/A
	2	430	350	430	350	195	159	195	159
4	1&3	2162	908	N/A	N/A	981	412	N/A	N/A
	2	1552	393	1641	393	704	178	744	178
5	1&3	2655	1019	N/A	N/A	1204	462	N/A	N/A
	2	1965	439	1909	418	891	199	866	190
6	1&3	3330	1155	N/A	N/A	1510	524	N/A	N/A
	2	2425	480	2451	480	1100	218	1112	218
7	1&3	5294	2579	N/A	N/A	2401	1170	N/A	N/A
	2	4140	1219	4652	784	1878	553	2110	356
8	1&3	6222	3033	N/A	N/A	2822	1376	N/A	N/A
	2	4952	1343	4559	783	2246	609	2068	355

## 150 PSIG (1034 KPA) MARINE WATERBOXES — TWO-STAGE COMPRESSORS, FRAME SIZE 6 ENGLISH (LB)

FRAME	NUMBER OF PASSES	COOLER			CONDENSER		
		RIGGING WGT		WATER WGT	RIGGING WGT		WATER WGT
		VICTAULIC	FLANGE		VICTAULIC	FLANGE	
A	1	2794	3124	6515	2582	2912	5648
	2	2454	2650	2979	2236	2432	2613
	3	2771	2899	4190	2840	3020	3950
B	1	—	—	—	2604	2934	6975
	2	—	—	—	2459	2719	3600
	3	—	—	—	2770	2950	4858

\* Add to cooler and condenser weights for total weights. Condenser weights may be found in the Heat Exchanger Weights tables on

pages 30-39. The first digit of the heat exchanger code (first column) is the heat exchanger frame size.

† Values are for Victaulic nozzles, two-pass dished head design.

**ADDITIONAL WEIGHTS FOR 19XR,XRV MARINE WATERBOXES\* (CONT)**  
**150 PSIG (1034 KPA) MARINE WATERBOXES — TWO-STAGE COMPRESSORS, FRAME SIZE 6 — SI (KG)**

FRAME	NUMBER OF PASSES	COOLER			CONDENSER		
		RIGGING WGT		WATER WGT	RIGGING WGT		WATER WGT
		VICTAULIC	FLANGE		VICTAULIC	FLANGE	
<b>A</b>	1	1267	1417	2955	1171	1321	2562
	2	1113	1202	2979	1014	1103	1185
	3	1157	1315	1900	1288	1370	1792
<b>B</b>	1	—	—	—	1181	1331	3162
	2	—	—	—	1115	1233	1633
	3	—	—	—	1256	1338	2203

\* Add to cooler and condenser weights for total weights. Condenser weights may be found in the Heat Exchanger Weights tables on pages 30-39. The first digit of the heat exchanger code (first column) is the heat exchanger frame size.

† Values are for Victaulic nozzles, two-pass dished head design.

**150 PSIG (1034 KPA) MARINE WATERBOXES — TWO-STAGE COMPRESSORS, FRAME SIZE 7 — ENGLISH (LB)**

FRAME	NUMBER OF PASSES	COOLER			CONDENSER		
		RIGGING WGT		WATER WGT	RIGGING WGT		WATER WGT
		VICTAULIC	FLANGE		VICTAULIC	FLANGE	
<b>B</b>	1	4045	4375	8,103	—	—	—
	2	3648	3908	4,139	—	—	—
	3	4160	4340	5,633	—	—	—
<b>C</b>	1	4828	5158	10,264	4273	4713	9,858
	2	4375	4635	5,201	3714	4044	4,826
	3	4957	5137	7,144	4434	4630	6,819
<b>D</b>	1	—	—	—	4863	5303	12,530
	2	—	—	—	4243	4573	6,074
	3	—	—	—	5079	5275	8,659

\* Add to cooler and condenser weights for total weights. Condenser weights may be found in the Heat Exchanger Weights tables on pages 30-39. The first digit of the heat exchanger code (first column) is the heat exchanger frame size.

† Values are for Victaulic nozzles, two-pass dished head design.

**150 PSIG (1034 KPA) MARINE WATERBOXES — TWO-STAGE COMPRESSORS, FRAME SIZE 7 — SI (KG)**

FRAME	NUMBER OF PASSES	COOLER			CONDENSER		
		RIGGING WGT		WATER WGT	RIGGING WGT		WATER WGT
		VICTAULIC	FLANGE		VICTAULIC	FLANGE	
<b>B</b>	1	1835	1984	3675	—	—	—
	2	1655	1773	1877	—	—	—
	3	1887	1969	2555	—	—	—
<b>C</b>	1	2190	2340	4655	1938	2138	4472
	2	1984	2102	2359	1685	1834	2189
	3	2248	2330	3240	2011	2100	3093
<b>D</b>	1	—	—	—	2206	2405	5684
	2	—	—	—	1925	2074	2755
	3	—	—	—	2303	2393	3928

\* Add to cooler and condenser weights for total weights. Condenser weights may be found in the Heat Exchanger Weights tables on pages 30-39. The first digit of the heat exchanger code (first column) is the heat exchanger frame size.

† Values are for Victaulic nozzles, two-pass dished head design.

## ADDITIONAL WEIGHTS FOR 19XR,XRV MARINE WATERBOXES\* (CONT) 300 PSIG (2068 KPA) ASME MARINE WATERBOXES — TWO-STAGE COMPRESSORS, FRAME SIZE 6\* — ENGLISH (LB)

FRAME	NUMBER OF PASSES	COOLER			CONDENSER		
		RIGGING WGT		WATER WGT	RIGGING WGT		WATER WGT
		VICTAULIC	FLANGE		VICTAULIC	FLANGE	
A	1	6379	6709	5058	5573	5903	4426
	2	5594	5790	2101	4834	5030	1890
	3	6031	6159	3005	5310	5490	2688
B	1	—	—	—	7084	7414	5509
	2	—	—	—	6474	6734	2577
	3	—	—	—	6816	6996	3340

\* Add to cooler and condenser weights for total weights. Condenser weights may be found in the Heat Exchanger Weights tables on

pages 30-39. The first digit of the heat exchanger code (first column) is the heat exchanger frame size.

## 300 PSIG (2068 KPA) ASME MARINE WATERBOXES — TWO-STAGE COMPRESSORS, FRAME SIZE 6\* — SI (KG)

FRAME	NUMBER OF PASSES	COOLER			CONDENSER		
		RIGGING WGT		WATER WGT	RIGGING WGT		WATER WGT
		VICTAULIC	FLANGE		VICTAULIC	FLANGE	
A	1	2893	3043	2294	2528	2678	2008
	2	2537	2626	953	2193	2282	857
	3	2736	2794	1363	2409	2490	1219
B	1	—	—	—	3213	3363	2499
	2	—	—	—	2937	3054	1169
	3	—	—	—	3092	3173	1515

\* Add to cooler and condenser weights for total weights. Condenser weights may be found in the Heat Exchanger Weights tables on

pages 30-39. The first digit of the heat exchanger code (first column) is the heat exchanger frame size.

## 300 PSIG (2068 KPA) ASME MARINE WATERBOXES — TWO-STAGE COMPRESSORS, FRAME SIZE 7\* — ENGLISH (LB)

FRAME	NUMBER OF PASSES	COOLER			CONDENSER		
		RIGGING WGT		WATER WGT	RIGGING WGT		WATER WGT
		VICTAULIC	FLANGE		VICTAULIC	FLANGE	
B	1	8,305	8,635	5783	—	—	—
	2	7,426	7,686	2382	—	—	—
	3	7,785	7,965	3268	—	—	—
C	1	11,001	11,331	7030	9,228	9,668	7591
	2	9,829	10,089	2708	8,003	8,333	3061
	3	10,343	10,053	3866	8,647	8,843	4468
D	1	—	—	—	12,940	13,380	9365
	2	—	—	—	11,170	11,500	3607
	3	—	—	—	12,042	12,238	5398

\* Add to cooler and condenser weights for total weights. Condenser weights may be found in the Heat Exchanger Weights tables on

pages 30-39. The first digit of the heat exchanger code (first column) is the heat exchanger frame size.

## 300 PSIG (2068 KPA) ASME MARINE WATERBOXES — TWO-STAGE COMPRESSORS, FRAME SIZE 7\* — SI (KG)

FRAME	NUMBER OF PASSES	COOLER			CONDENSER		
		RIGGING WGT		WATER WGT	RIGGING WGT		WATER WGT
		VICTAULIC	FLANGE		VICTAULIC	FLANGE	
B	1	3767	3917	2623	—	—	—
	2	3368	3486	1080	—	—	—
	3	3531	3612	1482	—	—	—
C	1	4990	5140	3188	4186	4385	3443
	2	4458	4576	1228	3630	3682	1388
	3	4692	4773	1753	3922	—	—
D	1	—	—	—	5869	5927	4547
	2	—	—	—	5067	5102	1925
	3	—	—	—	5462	—	—

\* Add to cooler and condenser weights for total weights. Condenser weights may be found in the Heat Exchanger Weights tables on

pages 30-39. The first digit of the heat exchanger code (first column) is the heat exchanger frame size.



**19XR,XRV WATERBOX COVER WEIGHTS — ENGLISH (LB)  
FRAMES 1, 2, AND 3; COOLER**

WATERBOX DESCRIPTION	COOLER					
	FRAME 1		FRAME 2		FRAME 3	
	STANDARD NOZZLES	FLANGED	STANDARD NOZZLES	FLANGED	STANDARD NOZZLES	FLANGED
NIH, 1 PASS COVER, 150 PSIG	177	204	287	318	287	318
NIH, 2 PASS COVER, 150 PSIG	185	218	287	340	287	340
NIH, 3 PASS COVER, 150 PSIG	180	196	294	310	294	310
MWB END COVER, 150 PSIG	—	—	315	315	315	315
NIH/MWB RETURN COVER, 150 PSIG	136	136	243	243	243	243
NIH, 1 PASS COVER, 300 PSIG	248	301	411	486	411	486
NIH, 2 PASS COVER, 300 PSIG	255	324	411	518	411	518
NIH, 3 PASS COVER, 300 PSIG	253	288	433	468	433	468
NIH PLAIN END COVER, 300 PSIG	175	175	291	291	291	291
MWB END COVER, 300 PSIG	—	—	619	619	619	619
MWB RETURN COVER, 300 PSIG	—	—	445	445	445	445

LEGEND

NIH — Nozzle-in-Head  
MWB — Marine Waterbox

NOTE: Weight for 2-pass cover, 150 psig, is included in the heat exchanger weights shown on pages 30-33.

**FRAMES 1, 2, AND 3; CONDENSER**

WATERBOX DESCRIPTION	CONDENSER					
	FRAME 1		FRAME 2		FRAME 3	
	STANDARD NOZZLES	FLANGED	STANDARD NOZZLES	FLANGED	STANDARD NOZZLES	FLANGED
NIH, 1 Pass Cover, 150 psig	177	204	260	297	260	297
NIH, 2 Pass Cover, 150 psig	185	218	265	318	265	318
NIH, 3 Pass Cover, 150 psig	180	196	272	288	272	288
MWB End Cover, 150 psig	—	—	234	234	234	234
NIH/MWB Return Cover, 150 psig	136	136	225	225	225	225
NIH, 1 Pass Cover, 300 psig	248	301	379	454	379	454
NIH, 2 Pass Cover, 300 psig	255	324	379	486	379	486
NIH, 3 Pass Cover, 300 psig	253	288	401	436	401	436
NIH Plain End Cover, 300 psig	175	175	270	270	270	270
MWB End Cover, 300 psig	—	—	474	474	474	474
MWB Return Cover, 300 psig	—	—	359	359	359	359

LEGEND

NIH — Nozzle-in-Head  
MWB — Marine Waterbox

NOTE: Weight for NIH 2-pass cover, 150 psig, is included in the heat exchanger weights shown on pages 30-33.

## 19XR,XRV WATERBOX COVER WEIGHTS — ENGLISH (LB) (CONT) FRAMES 4, 5, AND 6; COOLER

WATERBOX DESCRIPTION	COOLER					
	FRAME 4		FRAME 5		FRAME 6	
	STANDARD NOZZLES	FLANGED	STANDARD NOZZLES	FLANGED	STANDARD NOZZLES	FLANGED
NIH, 1 Pass Cover, 150 psig	148	185	168	229	187	223
NIH, 2 Pass Cover, 150 psig	202	256	224	276	257	330
NIH, 3 Pass Cover, 150 psig	473	489	617	634	765	791
MWB End Cover, 150 psig	317	317	393	393	487	487
NIH/MWB Return Cover, 150 psig	138	138	154	154	172	172
NIH, 1 Pass Cover, 300 psig	633	709	764	839	978	1053
NIH, 2 Pass Cover, 300 psig	626	689	761	867	927	1078
NIH, 3 Pass Cover, 300 psig	660	694	795	830	997	1050
NIH/MWB End Cover, 300 psig	522	522	658	658	834	834

LEGEND

NIH — Nozzle-in-Head  
MWB — Marine Waterbox

NOTE: Weight for NIH 2-pass cover, 150 psig, is included in the heat exchanger weights shown on pages 30-33.

## FRAMES 4, 5, AND 6; CONDENSER

WATERBOX DESCRIPTION	CONDENSER					
	FRAME 4		FRAME 5		FRAME 6	
	STANDARD NOZZLES	FLANGED	STANDARD NOZZLES	FLANGED	STANDARD NOZZLES	FLANGED
NIH, 1 Pass Cover, 150 psig	148	185	168	229	187	223
NIH, 2 Pass Cover, 150 psig	191	245	224	298	245	330
NIH, 3 Pass Cover, 150 psig	503	519	629	655	772	843
MWB End Cover and Bolt-on End Cover, 150 psig	317	317	393	393	487	487
NIH/MWB Return Cover, 150 psig	138	138	154	154	172	172
NIH, 1 Pass Cover, 300 psig	633	709	764	839	978	1053
NIH, 2 Pass Cover, 300 psig	622	729	727	878	923	1074
NIH, 3 Pass Cover, 300 psig	655	689	785	838	995	1049
NIH/MWB End Cover, 300 psig	522	522	658	658	834	834

LEGEND

NIH — Nozzle-in-Head  
MWB — Marine Waterbox

NOTE: Weight for NIH 2-pass cover, 150 psig, is included in the heat exchanger weights shown on pages 30-33.

**19XR,XRV WATERBOX COVER WEIGHTS — ENGLISH (LB) (CONT)  
FRAMES 7 AND 8; COOLER**

WATERBOX DESCRIPTION	COOLER			
	FRAME 7		FRAME 8	
	STANDARD NOZZLES	FLANGED	STANDARD NOZZLES	FLANGED
NIH, 1 Pass Cover, 150 psig	329	441	417	494
NIH, 2 Pass Cover, 150 psig	426	541	540	693
NIH, 3 Pass Cover, 150 psig	1250	1291	1629	1687
MWB End Cover, 150 psig	844	844	1125	1125
NIH/MWB Return Cover, 150 psig	315	315	404	404
NIH, 1 Pass Cover, 300 psig	1712	1883	2359	2523
NIH, 2 Pass Cover, 300 psig	1662	1908	2369	2599
NIH, 3 Pass Cover, 300 psig	1724	1807	2353	2516
NIH/MWB End Cover, 300 psig	1378	1378	1951	1951

LEGEND

NIH — Nozzle-in-Head  
MWB — Marine Waterbox

NOTE: Weight for NIH 2-pass cover, 150 psig, is included in the heat exchanger weights shown on pages 30-33.

**FRAMES 7 AND 8; CONDENSER**

WATERBOX DESCRIPTION	CONDENSER			
	FRAME 7		FRAME 8	
	STANDARD NOZZLES	FLANGED	STANDARD NOZZLES	FLANGED
NIH, 1 Pass Cover, 150 psig	329	441	417	494
NIH, 2 Pass Cover, 150 psig	404	520	508	662
NIH, 3 Pass Cover, 150 psig	1222	1280	1469	1527
MWB End Cover, 150 psig	781	781	1007	1007
Bolt-on MWB End Cover, 150 psig	700	700	1307	1307
NIH/MWB Return Cover, 150 psig	315	315	404	404
NIH, 1 Pass Cover, 300 psig	1690	1851	1986	2151
NIH, 2 Pass Cover, 300 psig	1628	1862	1893	2222
NIH, 3 Pass Cover, 300 psig	1714	1831	1993	2112
NIH/MWB End Cover, 300 psig	1276	1276	1675	1675

LEGEND

NIH — Nozzle-in-Head  
MWB — Marine Waterbox

NOTE: Weight for NIH 2-pass cover, 150 psig, is included in the heat exchanger weights shown on pages 30-33.

# Physical data (cont)



## 19XR,XRV WATERBOX COVER WEIGHTS — ENGLISH (LB) (CONT) TWO-STAGE COMPRESSOR FRAME 6; COOLER FRAME A

WATERBOX DESCRIPTION	PASSES	COOLER	
		Frame A	
		STANDARD NOZZLES	FLANGED
Dished Head, 150 psig	1	1006	1171
MWB End Cover, 150 psig	1	976	976
MWB End Cover (ASME), 300 psig	1	2460	2460
Dished Head, 150 psig	2	1140	1336
Dished Head (Return Cover), 150 psig	2	976	976
MWB End Cover, 150 psig	2	1068	1068
MWB End Cover (Return Cover), 150 psig	2	976	976
MWB End Cover (ASME), 300 psig	2	2460	2460
MWB End Cover (ASME) (Return Cover), 300 psig	2	2460	2460
Dished Head, 150 psig	3	1048	1112
MWB End Cover, 150 psig	3	1030	1030
MWB End Cover (ASME), 300 psig	3	2460	2460

**LEGEND**

**ASME** — American Society of Mechanical Engineers  
**MWB** — Marine Waterbox

**NOTES:**

1. Consult factory for 1 and 3 pass data.
2. Weight for dished head cover is included in the heat exchanger weights shown on pages 34-39.
3. 2 pass weight difference is due to division plate.

## TWO-STAGE COMPRESSOR FRAME 6; CONDENSER FRAME A AND B

WATERBOX DESCRIPTION	PASSES	CONDENSER			
		Frame A		Frame B	
		STANDARD NOZZLES	FLANGED	STANDARD NOZZLES	FLANGED
Dished Head, 150 psig	1	895	1060	1006	1171
MWB, 150 psig	1	859	859	976	976
MWB (ASME), 300 psig	1	2117	2117	2744	2744
Dished Head, 150 psig	2	981	1179	1140	1400
Dished Head (Return Cover), 150 psig	2	824	824	976	976
MWB 150 psig	2	907	907	1075	1075
MWB (Return), 150 psig	2	824	824	976	976
MWB (ASME), 300 psig	2	2117	2117	2744	2744
MWB Return Cover (ASME), 300 psig	2	2117	2117	2744	2744
Dished Head, 150 psig	3	982	1072	1050	1140
MWB End Cover, 150 psig	3	942	942	1020	1020
MWB End Cover (ASME), 300 psig	3	2117	2177	2744	2744

**LEGEND**

**ASME** — American Society of Mechanical Engineers  
**MWB** — Marine Waterbox

**NOTES:**

1. Consult factory for 1 and 3 pass data.
2. Weight for dished head cover is included in the heat exchanger weights shown on pages 34-39.
3. 2 pass weight difference is due to division plate.

**19XR,XRV WATERBOX COVER WEIGHTS — ENGLISH (LB) (CONT)  
TWO-STAGE COMPRESSOR FRAME 7; COOLER FRAMES B, C**

WATERBOX DESCRIPTION	PASSES	COOLER			
		Frame B		Frame C	
		STANDARD NOZZLES	FLANGED	STANDARD NOZZLES	FLANGED
Dished Head, 150 psig	1	1380	1545	1849	2014
MWB End Cover, 150 psig	1	1366	1366	1835	1835
MWB End Cover (ASME), 300 psig	1	3425	3425	4805	4805
Dished Head, 150 psig	2	1589	1849	2076	2336
Dished Head (Return Cover), 150 psig	2	1367	1367	1836	1836
MWB End Cover, 150 psig	2	1489	1489	1987	1987
MWB (Return Cover), 150 psig	2	1367	1367	1836	1836
MWB End Cover (ASME), 300 psig	2	3425	3425	4805	4805
MWB (Return Cover), 300 psig	2	3425	3425	4805	4805
Dished Head, 150 psig	3	1514	1604	2028	2118
MWB End Cover, 150 psig	3	1506	1506	1995	1995
MWB End Cover (ASME), 300 psig	3	3425	3425	4805	4805

LEGEND

ASME — American Society of Mechanical Engineers  
MWB — Marine Waterbox

NOTES:

1. Consult factory for 1 and 3 pass data.
2. Weight for dished head cover is included in the heat exchanger weights shown on pages 34-39.
3. 2 pass weight difference is due to division plate.

**TWO-STAGE COMPRESSOR FRAME 7; CONDENSER FRAMES C, D**

WATERBOX DESCRIPTION	PASSES	CONDENSER			
		Frame C		Frame D	
		STANDARD NOZZLES	FLANGED	STANDARD NOZZLES	FLANGED
Dished Head, 150 psig	1	1380	1600	1849	2029
MWB End Cover, 150 psig	1	1367	1367	1835	1835
MWB End Cover (ASME), 300 psig	1	3639	3639	5249	5249
Dished Head, 150 psig	2	1589	1919	2076	2406
Dished Head (Return Cover), 150 psig	2	1367	1367	1836	1836
MWB End Cover, 150 psig	2	1497	1497	1988	1988
MWB (Return Cover), 150 psig	2	1367	1367	1836	1836
MWB End Cover (ASME), 300 psig	2	3639	3639	5249	5249
MWB (Return Cover) (ASME), 300 psig	2	3639	3639	5249	5249
Dished Head, 150 psig	3	1514	1612	2028	2126
MWB End Cover, 150 psig	3	1493	1493	1993	1993
MWB End Cover (ASME), 300 psig	3	3639	3639	5249	5249

LEGEND

ASME — American Society of Mechanical Engineers  
MWB — Marine Waterbox

NOTES:

1. Consult factory for 1 and 3 pass data.
2. Weight for dished head cover is included in the heat exchanger weights shown on pages 34-39.
3. 2 pass weight difference is due to division plate.

## 19XR,XRV WATERBOX COVER WEIGHTS — SI (KG) FRAMES 1, 2, 3; COOLER

WATERBOX DESCRIPTION	COOLER					
	FRAME 1		FRAME 2		FRAME 3	
	STANDARD NOZZLES	FLANGED	STANDARD NOZZLES	FLANGED	STANDARD NOZZLES	FLANGED
NIH, 1 Pass Cover, 1034 kPa	80	92	130	144	130	144
NIH, 2 Pass Cover, 1034 kPa	84	99	130	154	130	154
NIH, 3 Pass Cover, 1034 kPa	82	88	133	141	133	141
MWB End Cover, 1034 kPa	—	—	143	143	143	143
NIH/MWB Return Cover, 1034 kPa	62	62	110	110	110	110
NIH, 1 Pass Cover, 2068 kPa	112	137	186	220	186	220
NIH, 2 Pass Cover, 2068 kPa	116	147	186	235	186	235
NIH, 3 Pass Cover, 2068 kPa	115	131	196	212	196	212
NIH Plain End Cover, 2068 kPa	79	79	132	132	132	132
MWB End Cover, 2068 kPa	—	—	281	281	281	281
MWB Return Cover, 2068 kPa	—	—	202	202	202	202

LEGEND

NIH — Nozzle-in-Head  
MWB — Marine Waterbox

NOTE: Weight for NIH 2-pass cover, 1034 kPa, is included in the heat exchanger weights shown on pages 30-33.

## FRAMES 1, 2, 3; CONDENSER

WATERBOX DESCRIPTION	CONDENSER					
	FRAME 1		FRAME 2		FRAME 3	
	STANDARD NOZZLES	FLANGED	STANDARD NOZZLES	FLANGED	STANDARD NOZZLES	FLANGED
NIH, 1 Pass Cover, 1034 kPa	80	92	118	135	118	135
NIH, 2 Pass Cover, 1034 kPa	84	99	120	144	120	144
NIH, 3 Pass Cover, 1034 kPa	82	88	123	131	123	131
MWB End Cover, 1034 kPa	—	—	106	106	106	106
NIH/MWB Return Cover, 1034 kPa	62	62	102	102	102	102
NIH, 1 Pass Cover, 2068 kPa	112	137	172	206	172	206
NIH, 2 Pass Cover, 2068 kPa	116	147	172	220	172	220
NIH, 3 Pass Cover, 2068 kPa	115	131	182	198	182	198
NIH Plain End Cover, 2068 kPa	79	79	122	122	122	122
MWB End Cover, 2068 kPa	—	—	215	215	215	215
MWB Return Cover, 2068 kPa	—	—	163	163	163	163

LEGEND

NIH — Nozzle-in-Head  
MWB — Marine Waterbox

NOTE: Weight for NIH 2-pass cover, 1034 kPa, is included in the heat exchanger weights shown on pages 30-33.

**19XR,XRV WATERBOX COVER WEIGHTS — SI (KG) (CONT)  
FRAMES 4, 5, 6; COOLER**

WATERBOX DESCRIPTION	COOLER					
	FRAME 4		FRAME 5		FRAME 6	
	STANDARD NOZZLES	FLANGED	STANDARD NOZZLES	FLANGED	STANDARD NOZZLES	FLANGED
NIH, 1 Pass Cover, 1034 kPa	67	84	76	104	85	101
NIH, 2 Pass Cover, 1034 kPa	92	116	102	125	117	150
NIH, 3 Pass Cover, 1034 kPa	215	222	280	288	347	359
MWB End Cover, 1034 kPa	144	144	178	178	221	221
NIH/MWB Return Cover, 1034 kPa	63	63	70	70	78	78
NIH, 1 Pass Cover, 2068 kPa	287	322	347	381	444	478
NIH, 2 Pass Cover, 2068 kPa	284	313	345	394	420	489
NIH, 3 Pass Cover, 2068 kPa	299	315	361	376	452	476
NIH/MWB End Cover, 2068 kPa	237	237	298	298	378	378

LEGEND

NIH — Nozzle-in-Head  
MWB — Marine Waterbox

NOTE: Weight for NIH 2-pass cover, 1034 kPa, is included in the heat exchanger weights shown on pages 30-33.

**FRAMES 4, 5, 6; CONDENSER**

WATERBOX DESCRIPTION	CONDENSER					
	FRAME 4		FRAME 5		FRAME 6	
	STANDARD NOZZLES	FLANGED	STANDARD NOZZLES	FLANGED	STANDARD NOZZLES	FLANGED
NIH, 1 Pass Cover, 1034 kPa	67	84	76	104	85	101
NIH, 2 Pass Cover, 1034 kPa	87	111	102	135	111	150
NIH, 3 Pass Cover, 1034 kPa	228	235	285	297	350	382
MWB End Cover and Bolt-on End Cover, 1034 kPa	144	144	178	178	221	221
NIH/MWB Return Cover, 1034 kPa	63	63	70	70	78	78
NIH, 1 Pass Cover, 2068 kPa	287	322	347	381	444	478
NIH, 2 Pass Cover, 2068 kPa	282	331	330	393	419	487
NIH, 3 Pass Cover, 2068 kPa	297	313	356	376	451	476
NIH/MWB End Cover, 2068 kPa	237	237	298	298	378	378

LEGEND

NIH — Nozzle-in-Head  
MWB — Marine Waterbox

NOTE: Weight for NIH 2-pass cover, 1034 kPa, is included in the heat exchanger weights shown on pages 30-33.



## 19XR,XRV WATERBOX COVER WEIGHTS — SI (KG) (CONT) FRAMES 7 AND 8; COOLER

WATERBOX DESCRIPTION	COOLER			
	FRAME 7		FRAME 8	
	STANDARD NOZZLES	FLANGED	STANDARD NOZZLES	FLANGED
NIH, 1 Pass Cover, 1034 kPa	149	200	189	224
NIH, 2 Pass Cover, 1034 kPa	193	245	245	314
NIH, 3 Pass Cover, 1034 kPa	567	586	739	765
MWB End Cover, 1034 kPa	383	383	510	510
NIH/MWB Return Cover, 1034 kPa	143	143	183	183
NIH, 1 Pass Cover, 2068 kPa	777	854	1070	1144
NIH, 2 Pass Cover, 2068 kPa	754	865	1075	1179
NIH, 3 Pass Cover, 2068 kPa	782	820	1067	1141
NIH/MWB End Cover, 2068 kPa	625	625	885	885

LEGEND

NIH — Nozzle-in-Head  
MWB — Marine Waterbox

NOTE: Weight for NIH 2-pass cover, 1034 kPa, is included in the heat exchanger weights shown on pages 30-33.

## FRAMES 7 AND 8; CONDENSER

WATERBOX DESCRIPTION	CONDENSER			
	FRAME 7		FRAME 8	
	STANDARD NOZZLES	FLANGED	STANDARD NOZZLES	FLANGED
NIH, 1 Pass Cover, 1034 kPa	149	200	189	224
NIH, 2 Pass Cover, 1034 kPa	183	236	230	300
NIH, 3 Pass Cover, 1034 kPa	554	580	666	693
MWB End Cover, 1034 kPa	354	354	457	457
Bolt-on MWB End Cover, 1034 kPa	318	318	593	593
NIH/MWB Return Cover, 1034 kPa	143	143	183	183
NIH, 1 Pass Cover, 2068 kPa	767	840	901	976
NIH, 2 Pass Cover, 2068 kPa	738	845	859	1008
NIH, 3 Pass Cover, 2068 kPa	777	831	904	958
NIH/MWB End Cover, 2068 kPa	579	579	760	760

LEGEND

NIH — Nozzle-in-Head  
MWB — Marine Waterbox

NOTE: Weight for NIH 2-pass cover, 1034 kPa, is included in the heat exchanger weights shown on pages 30-33.

**19XR,XRV WATERBOX COVER WEIGHTS — SI (KG) (CONT)**  
**TWO-STAGE COMPRESSOR FRAME 6; COOLER FRAME A**

WATERBOX DESCRIPTION	PASSES	COOLER	
		Frame A	
		STANDARD NOZZLES	FLANGED
Dished Head, 1034 kPa	1	456	531
MWB End Cover, 1034 kPa	1	443	443
MWB End Cover (ASME), 2068 kPa	1	1116	1116
Dished Head, 1034 kPa	2	517	606
Dished Head (Return Cover), 1034 kPa	2	443	443
MWB End Cover, 1034 kPa	2	484	484
MWB End Cover (Return Cover), 1034 kPa	2	443	443
MWB End Cover (ASME), 2068 kPa	2	1116	1116
MWB End Cover (ASME) (Return Cover), 2068 kPa	2	1116	1116
Dished Head, 1034 kPa	3	475	504
MWB End Cover, 1034 kPa	3	467	467
MWB End Cover (ASME), 2068 kPa	3	1116	1116

LEGEND

ASME — American Society of Mechanical Engineers  
MWB — Marine Waterbox

NOTES:

1. Consult factory for 1 and 3 pass data.
2. Weight for dished head cover is included in the heat exchanger weights shown on pages 34-39.
3. 2 pass weight difference is due to division plate.

**TWO-STAGE COMPRESSOR FRAME 6; CONDENSER FRAMES A, B**

WATERBOX DESCRIPTION	PASSES	CONDENSER			
		Frame A		Frame B	
		STANDARD NOZZLES	FLANGED	STANDARD NOZZLES	FLANGED
Dished Head, 1034 kPa	1	406	481	473	547
MWB, 1034 kPa	1	390	390	443	443
MWB (ASME), 2068 kPa	1	960	960	1292	1292
Dished Head, 1034 kPa	2	445	535	574	633
Dished Head (Return Cover), 1034 kPa	2	374	374	481	481
MWB 1034 kPa	2	411	411	630	630
MWB End Cover, 1034 kPa	2	374	411	488	488
MWB (ASME), 2068 kPa	2	960	1083	1440	1440
MWB Return Cover (ASME), 2068 kPa	2	960	960	1245	1245
Dished Head, 1034 kPa	3	445	486	476	517
MWB End Cover, 1034 kPa	3	427	427	463	463
MWB End Cover (ASME), 2068 kPa	3	960	987	1245	1245

LEGEND

ASME — American Society of Mechanical Engineers  
MWB — Marine Waterbox

NOTES:

1. Consult factory for 1 and 3 pass data.
2. Weight for dished head cover is included in the heat exchanger weights shown on pages 34-39.
3. 2 pass weight difference is due to division plate.

## 19XR,XRV WATERBOX COVER WEIGHTS — SI (KG) (CONT) TWO-STAGE COMPRESSOR FRAME 7; COOLER FRAMES B, C

WATERBOX DESCRIPTION	PASSES	COOLER			
		Frame B		Frame C	
		STANDARD NOZZLES	FLANGED	STANDARD NOZZLES	FLANGED
Dished Head, 1034 kPa	1	626	701	839	914
MWB End Cover, 1034 kPa	1	620	620	832	832
MWB End Cover (ASME), 2068 kPa	1	1554	1554	2180	2180
Dished Head, 1034 kPa	2	721	839	942	1060
Dished Head (Return Cover), 1034 kPa	2	620	620	833	833
MWB End Cover, 1034 kPa	2	675	675	901	901
MWB (Return Cover), 1034 kPa	2	620	620	833	833
MWB End Cover (ASME), 2068 kPa	2	1554	1554	2180	2180
MWB (Return Cover), 2068 kPa	2	1554	1554	2180	2180
Dished Head, 1034 kPa	3	687	728	920	961
MWB End Cover, 1034 kPa	3	683	683	905	905
MWB End Cover (ASME), 2068 kPa	3	1554	1554	2180	2180

### LEGEND

**ASME** — American Society of Mechanical Engineers  
**MWB** — Marine Waterbox

### NOTES:

1. Consult factory for 1 and 3 pass data.
2. Weight for dished head cover is included in the heat exchanger weights shown on pages 34-39.
3. 2 pass weight difference is due to division plate.

## TWO-STAGE COMPRESSOR FRAME 7; CONDENSER FRAMES C, D

WATERBOX DESCRIPTION	PASSES	CONDENSER			
		Frame C		Frame D	
		STANDARD NOZZLES	FLANGED	STANDARD NOZZLES	FLANGED
Dished Head, 1034 kPa	1	626	726	839	920
MWB End Cover, 1034 kPa	1	620	620	832	832
MWB End Cover (ASME), 2068 kPa	1	1651	1651	2353	2353
Dished Head, 1034 kPa	2	721	870	942	1091
Dished Head (Return Cover), 1034 kPa	2	620	620	833	833
MWB End Cover, 1034 kPa	2	679	679	902	902
MWB (Return Cover), 1034 kPa	2	620	620	833	833
MWB End Cover (ASME), 2068 kPa	2	1651	1651	2381	2381
MWB (Return Cover) (ASME), 2068 kPa	2	1651	1651	2381	2381
Dished Head, 1034 kPa	3	687	731	920	964
MWB End Cover, 1034 kPa	3	677	677	904	904
MWB End Cover (ASME), 2068 kPa	3	1651	1651	2381	2381

### LEGEND

**ASME** — American Society of Mechanical Engineers  
**MWB** — Marine Waterbox

### NOTES:

1. Consult factory for 1- and 3-pass data.
2. Weight for dished head cover is included in the heat exchanger weights shown on pages 34-39.
3. 2-pass weight difference is due to division plate.

# Options and accessories



ITEM	OPTION (FACTORY INSTALLED)	ACCESSORY (FIELD INSTALLED)
Unit-Mounted Variable Frequency Drive (Available for Low Voltage Only)	X	
Free-Standing Low Voltage Variable Frequency Drive		X
Free-Standing Medium Voltage Variable Frequency Drive		X
Free-Standing Starter		X
Unit-Mounted Low-Voltage Wye-Delta or Solid-State Starters (Available on Heat Exchanger Frame Sizes 1 to 7 Only)	X	
Shipped Factory Charged with Refrigerant (can be shipped separate)	X	
One, 2, or 3 Pass Cooler or Condenser Water-side Construction	X	
Hot Gas Bypass	X	
Thermal Insulation (Except Waterbox Covers)	X	
Nozzle-in Head Waterbox, 300 psig (2068 kPa)	X	
Marine Waterboxes, 150 psig (1034 kPa)*	X	
Marine Waterboxes, 300 psig (2068 kPa), ASME Certified*	X	
Marine Bolt-on Waterboxes for Condenser, 150 psig (1034 kPa) with Titanium-Clad Tubesheets (Available on Condenser Frame Sizes 4 to 8 Only)	X	
Flanged Cooler and/or Condenser Waterbox Nozzles†	X	
Waterbox Hinges**	X	
Zinc Anodes	X	
0.028 or 0.035 in. (0.711 or 0.889 mm) Internally/Externally Enhanced Copper Tubing — Cooler/Condenser	X	
0.028 or 0.035 in. (0.711 or 0.889 mm) Smooth Bore/Externally Enhanced Copper Tubing — Cooler/Condenser	X	
0.028 or 0.035 in. (0.711 or 0.889 mm) Smooth Bore/Externally Enhanced Cupronickel Tubing — Cooler/Condenser	X	
0.028 or 0.035 in. (0.711 or 0.889 mm) Internally/Externally Enhanced Cupronickel Tubing — Cooler/Condenser	X	
0.025 or 0.028 in. (0.635 or 0.711 mm) Wall Tubes, Titanium, Internally Enhanced — Condenser	X	
Export Crating	X	
Customer Factory Performance Testing	X	
Extended Warranty (North America only)	X	
Service Contract	X	
Refrigerant Isolation Valves	X	
Unit-Mounted Pumpout Unit (Available on Heat Exchanger Frames Sizes 2 to 5, E Only)	X	
Seismic Kit (Select Models)	X	
Stand-Alone Pumpout Unit		X
Separate Storage Tank and Pumpout Unit		X
Soleplate Package		X
Multiple Chiller System Remote Temperature Sensor		X
BACnet†† Communication Option (Compressor Frames 2 to 5, E, BACnet over MS/TP)	X	
BACnet†† Communication Option (Compressor Frames 6 and 7, BACnet IP)	X	
BACnet†† Carrier Translator (Compressor Frames 2 to 5, E)		X
LonWorks*** Carrier Translator (Compressor Frames 2 to 5, E)		X
Discharge Line Sound Reduction Kit		X
Acoustical Sound Insulation Kit		X
Spring Isolator Kit		X

\* Optional marine waterboxes are NOT available with all configurations. They are available for 19XR heat exchanger frames 2-8 and 19XR; two-stage compressors frame sizes 6 and 7; and heat exchanger frame sizes A, B, C, and D. Standard waterboxes for both 19XR and 19XRV chillers are nozzle-in-head type, 150 psig (1034 kPa).

† Standard waterbox nozzles are Victaulic type. Flanged nozzles are available as an option with either nozzle-in-head type waterboxes or marine waterboxes.

\*\* Not available with all configurations.

†† BACnet is a registered trademark of ASHRAE (American Society of Heating, Refrigerating, and Air-Conditioning Engineers) (English units of measure only).

\*\*\* LonWorks is a registered trademark of Echelon Corporation.

NOTE: The BACnet option for 19XR Compressor Frames 6 and 7 (PIC 5 controls) provides BACnet over IP communication only. This option disables CCN communication and i-Vu@ considers this option to be a third-party device. For higher levels of integration, contact your local Carrier Controls office.

# Options and accessories (cont)



## UNIT-MOUNTED STARTER AND VFD FEATURES AND OPTIONS\*

ITEM	WYE-DELTA	SOLID STATE	VFD
ISM	S	N/A	S
Branch Oil Pump Circuit Breaker	S	S	S
Controls/Oil Heater Transformer with Branch Circuit Breaker	S	S	S
Microprocessor Based Overload Trip Protection	S	S	S
Main Power Disconnect (Non-Fused Type)	S	N/A	N/A
Main Power Circuit Breaker	N/A	S	S
High Interrupt Capacity Main Circuit Breaker	O	O	O
Phase Loss/Reversal Imbalance Protection	S	S	S
Three Phase Ground Fault Protection†	O	O	S
Integral SCR Bypass Contactor	N/A	S	N/A
Three-Phase Ammeter	O	O	N/A
Three-Phase Voltmeter	O	O	N/A
Three-Phase Over/Under Voltage Protection	S	S	S
Power Factor Digital Display	S	S	S
Frequency Digital Display	S	S	S
Digital Watt Display	O	O	O
Digital Watt Hour Display	O	O	O
Digital Power Factor Display	O	O	O
Demand Kilowatt Display	O	O	O
Lightning Arrestor and Surge Capacitor Package	O	O	N/A
Power Factor Correction Capacitors	O	O	N/A

LEGEND  
**ISM** — Integrated Starter Module  
**N/A** — Not Applicable  
**O** — Optional  
**S** — Standard Feature  
**SCR** — Silicon Control Rectifier  
**VFD** — Variable Frequency Drive

\* For free-standing starters, refer to the E-CAT Free Standing Starters builder software. Refer to the E-CAT Chiller builder software for all VFD options, as some options may not be available for all VFD models.

† Low voltage: phase to phase and phase to ground. Medium voltage: phase to phase and phase to ground.

## 19XR,XRV DIMENSIONS (NOZZLE-IN-HEAD WATERBOX)

HEAT EXCHANGER SIZE	A (LENGTH, WITH NOZZLE-IN-HEAD WATERBOX)						19XR B (WIDTH)		19XR C (HEIGHT)		19XRV B (WIDTH)		19XRV C (HEIGHT)
	1-PASS		2-PASS*		3-PASS		FT-IN.	MM	FT-IN.	MM	FT-IN.	MM	
	FT-IN.	MM	FT-IN.	MM	FT-IN.	MM							
10 TO 12	11- 11	3632	11- 4	3464	11- 11	3632	5- 27/8	1597	6- 11/4	1861	5- 27/8	1597	
15 TO 17	14- 2 1/2	4331	13- 7 1/2	4163	14- 2 1/2	4331	5- 27/8	1597	6- 11/4	1861	5- 27/8	1597	
20 TO 22	12- 0 1/2	3670	11- 5 1/8	3483	12- 0 1/2	3670	5- 67/16	1688	6- 3 1/4	1911	5- 67/16	1688	
30 TO 32†	14- 4	4369	13- 8 5/8	4182	14- 4	4369	5- 73/16	1707	6- 9 5/8	2073	5- 67/16	1688	
30 TO 32**	14- 4	4369	13- 8 5/8	4182	14- 4	4369	5- 73/16	1707	6- 9 5/8	2073	5- 6 1/8	1680	
35 TO 37†	16- 0 1/2	4889	15- 5 1/8	4703	16- 0 1/2	4889	5- 73/16	1707	6- 9 5/8	2073	5- 67/16	1688	
35 TO 37**	16- 0 1/2	4889	15- 5 1/8	4703	16- 0 1/2	4889	5- 73/16	1707	6- 9 5/8	2073	5- 6 1/8	1680	
40 TO 42	14- 10	4521	14- 3 5/8	4360	14- 6 3/4	4439	6- 3 1/8	1908	7- 0 3/4	2153	6- 2	1880	
45 TO 47	16- 6 1/2	5042	16- 0 1/8	4880	16- 3 1/4	4959	6- 3 1/8	1908	7- 0 3/4	2153	6- 2	1880	
50 TO 52**	14- 11	4546	14- 5	4395	14- 7 1/4	4451	6- 8 7/8	2054	7- 2 3/8	2194	6- 6 1/2	1994	
50 TO 54, 5K TO 5R††	14- 11	4546	14- 5	4395	14- 7 1/4	4451	6- 8 7/8	2054	7- 2 3/8	2194	6- 7 7/8	2029	
5A TO 5C	14- 11	4546	14- 5	4395	14- 7 1/4	4451	6- 8 7/8	2054	7- 2 3/8	2194	6- 8 7/8	2054	
55 TO 57**	16- 7 1/2	5067	16- 1 1/2	4915	16- 3 3/4	4972	6- 8 7/8	2054	7- 2 3/8	2194	6- 6 1/2	1994	
55 TO 59, 5T TO 5Z††	16- 7 1/2	5067	16- 1 1/2	4915	16- 3 3/4	4972	6- 8 7/8	2054	7- 2 3/8	2194	6- 7 7/8	2029	
5F TO 5H	16- 7 1/2	5067	16- 1 1/2	4915	16- 3 3/4	4972	6- 8 7/8	2054	7- 2 3/8	2194	6- 8 7/8	2054	
60 TO 64, 6K TO 6R	15- 0	4572	14- 5 3/4	4413	14- 7 3/4	4464	6- 0 5/8	2124	7- 4 3/8	2245	6- 10 5/8	2124	
65 TO 69, 6T TO 6Z	16- 8 1/2	5093	16- 2 1/4	4934	16- 4 1/4	4985	6- 0 5/8	2124	7- 4 3/8	2245	6- 10 5/8	2124	
70 TO 74, 7K TO 7R††	17- 1 1/2	5219	16- 11 1/2	5169	16- 10	5131	7- 11 1/2	2426	9- 6 1/4	2972	9- 1 3/8	2778	
70 TO 74, 7K TO 7R***	17- 1 1/2	5219	16- 11 1/2	5169	16- 10	5131	7- 11 1/2	2426	9- 6 1/4	2972	9- 3 5/8	2835	
75 TO 79, 7T TO 7Z	19- 1 1/2	5829	18- 11 1/2	5779	18- 10	5740	7- 11 1/2	2426	9- 6 1/4	2972	9- 3 5/8	2835	
80 TO 84, 8K TO 8R	17- 4 1/2	5296	17- 1	5207	16- 10 1/2	5143	8- 10 3/4	2711	9- 8 1/8	3029	10- 0 9/16	3063	
85 TO 89, 8T TO 8Z	19- 4 1/2	5905	19- 1	5817	18- 10 1/2	5753	8- 10 3/4	2711	9- 8 1/8	3029	10- 0 9/16	3063	

See Note 7

- \* Assumes both cooler and condenser nozzles on same end of chiller.
- † Compressor frame size 2.
- \*\* Compressor frame size 3.
- †† Compressor frame size 4.
- \*\*\* Compressor frame size 5 and E.

**NOTES:**

1. Service access should be provided per American Society of Heating, Refrigerating, and Air-Conditioning Engineers (ASHRAE) 15, latest edition, National Fire Protection Association (NFPA) 70, and local safety code.
2. Allow at least 3 ft (915 mm) overhead clearance for service rigging for frame 2-4 compressor. Overhead clearance for service rigging frame 5 and E compressor should be 5 ft (1524 mm).

3. Dimensions are approximate. Certified drawings available upon request.
4. Marine waterboxes may add 6 in. (152 mm) to the width of the machine. See certified drawings for details.
5. 'A' length dimensions shown are for standard 150 psig (1034 kPa) design and Victaulic connections. The 300 psig (2068 kPa) design and/or flanges will add length. See certified drawings.
6. Not all waterbox/pass combinations are available with unit-mounted VFD. Check selection program and Drawing Manager for availability.
7. 19XRV heights can vary depending on the configuration. Check 19XRV certified drawings for height information.

## 19XR,XRV DIMENSIONS

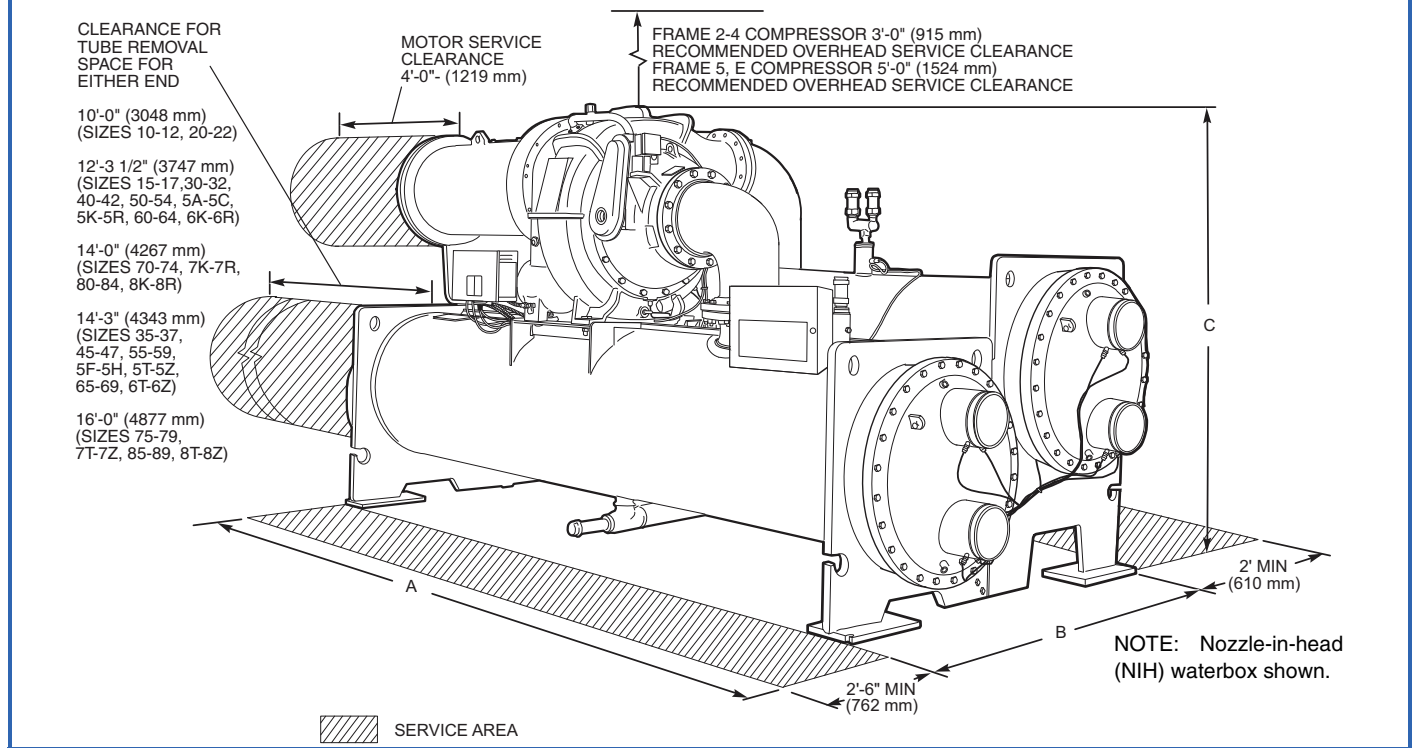

### 19XR,XRV DIMENSIONS — SINGLE-STAGE COMPRESSOR AND TWO-STAGE COMPRESSOR FRAME SIZE E (MARINE WATERBOX)

HEAT EXCHANGER SIZE	A (LENGTH, MARINE WATERBOX)				19XR B WIDTH		19XRV B WIDTH		19XR,XRV C HEIGHT
	2-Pass *		1 or 3-Pass †		ft-in.	mm	ft-in.	mm	
10 to 12	NA	NA	NA	NA	NA	NA	NA	NA	See Note 6
15 to 17	NA	NA	NA	NA	NA	NA	NA	NA	
20 to 22	12- 5 <sup>1</sup> / <sub>2</sub>	3797	14- 1 <sup>1</sup> / <sub>4</sub>	4299	6- 1 <sup>1</sup> / <sub>16</sub>	1856	6- 1 <sup>1</sup> / <sub>16</sub>	1856	
30 to 32	14- 9	4496	16- 4 <sup>3</sup> / <sub>4</sub>	4997	6- 1 <sup>1</sup> / <sub>16</sub>	1856	6- 1 <sup>1</sup> / <sub>16</sub>	1856	
35 to 37	16- 5 <sup>1</sup> / <sub>2</sub>	5017	18- 1 <sup>1</sup> / <sub>4</sub>	5518	6- 1 <sup>1</sup> / <sub>16</sub>	1856	6- 1 <sup>1</sup> / <sub>16</sub>	1856	
40 to 42	15- 2 <sup>3</sup> / <sub>4</sub>	4642	16- 8 <sup>1</sup> / <sub>4</sub>	5086	6- 3 <sup>1</sup> / <sub>4</sub>	1911	6- 3 <sup>1</sup> / <sub>4</sub>	1911	
45 to 47	16- 11 <sup>1</sup> / <sub>4</sub>	5163	18- 4 <sup>3</sup> / <sub>4</sub>	5607	6- 3 <sup>1</sup> / <sub>4</sub>	1911	6- 3 <sup>1</sup> / <sub>4</sub>	1911	
50 to 54, 5K to 5R	15- 3 <sup>1</sup> / <sub>2</sub>	4661	16- 8 <sup>1</sup> / <sub>2</sub>	5093	6- 8 <sup>7</sup> / <sub>8</sub>	2054	6- 8 <sup>7</sup> / <sub>8</sub>	2054	
5A to 5C	15- 3 <sup>1</sup> / <sub>2</sub>	4661	16- 8 <sup>1</sup> / <sub>2</sub>	5093	6- 8 <sup>7</sup> / <sub>8</sub>	2054	6- 8 <sup>7</sup> / <sub>8</sub>	2054	
55 to 59, 5T to 5Z	17- 0	5182	18- 5	5613	6- 8 <sup>7</sup> / <sub>8</sub>	2054	6- 8 <sup>7</sup> / <sub>8</sub>	2054	
5F to 5H	17- 0	5182	18- 5	5613	6- 8 <sup>7</sup> / <sub>8</sub>	2054	6- 8 <sup>7</sup> / <sub>8</sub>	2054	
60 to 64, 6K to 6R	15- 4 <sup>1</sup> / <sub>8</sub>	4677	16- 8 <sup>3</sup> / <sub>4</sub>	5099	6- 11 <sup>3</sup> / <sub>4</sub>	2127	6- 11 <sup>3</sup> / <sub>4</sub>	2127	
65 to 69, 6T to 6Z	17- 0 <sup>5</sup> / <sub>8</sub>	5197	18- 5 <sup>1</sup> / <sub>4</sub>	5620	6- 11 <sup>3</sup> / <sub>4</sub>	2127	6- 11 <sup>3</sup> / <sub>4</sub>	2127	
70 to 74, 7K to 7R	18- 3 <sup>5</sup> / <sub>8</sub>	5579	19- 9 <sup>3</sup> / <sub>4</sub>	6039	8- 8 <sup>1</sup> / <sub>8</sub>	2645	9- 6 <sup>3</sup> / <sub>8</sub>	2905	
75 to 79, 7T to 7Z	20- 3 <sup>5</sup> / <sub>8</sub>	6188	21- 9 <sup>3</sup> / <sub>4</sub>	6649	8- 8 <sup>1</sup> / <sub>8</sub>	2645	9- 6 <sup>3</sup> / <sub>8</sub>	2905	
80 to 84, 8K to 8R	18- 4	5583	19- 10 <sup>1</sup> / <sub>2</sub>	6058	9- 5 <sup>5</sup> / <sub>8</sub>	2886	10- 5	3175	
85 to 89, 8T to 8Z	20- 4	6198	21- 10 <sup>1</sup> / <sub>2</sub>	6668	9- 5 <sup>5</sup> / <sub>8</sub>	2886	10- 5	3175	

\* Assumes both cooler and condenser nozzles on same end of chiller.  
 † 1- or 3-pass length applies if cooler is a 1- or 3-pass design.

#### NOTES:

- Service access should be provided per American Society of Heating, Refrigerating, and Air-Conditioning Engineers (ASHRAE) 15, latest edition, National Fire Protection Association (NFPA) 70, and local safety code.
- Allow at least 3 ft (915 mm) overhead clearance for service rigging for frame 2-4 compressor. Overhead clearance for service rigging frame 5 and frame E compressor should be 5 ft (1524 mm).

- Dimensions are approximate. Certified drawings available upon request.
- Marine waterboxes may add 6 in. (152 mm) to the width of the machine. See certified drawings for details.
- 'A' length dimensions shown are for standard 150 psig (1034 kPa) design and Victaulic connections. The 300 psig (2068 kPa) design and/or flanges will add length. See certified drawings.
- 19XR,XRV heights can vary depending on the configuration. Check 19XR,XRV certified drawings for height information.
- Not all waterbox/pass combinations are available with unit-mounted VFD (variable frequency drive). Check selection program for availability.



### 19XR DIMENSIONS — TWO-STAGE COMPRESSOR FRAME SIZES 6 AND 7 (DISHD HEAD WATERBOX)

COOLER HEAT EXCHANGER SIZE	CONDENSER HEAT EXCHANGER SIZE	A (LENGTH, DISHD HEAD WATERBOX)						19XR B WIDTH		19XR C HEIGHT
		1-Pass		2-Pass		3-Pass		ft-in.	mm	
		ft-in.	mm	ft-in.	mm	ft-in.	mm			
A4*	A4*	17- 8	5385	17- 6 <sup>3</sup> / <sub>4</sub>	5353	17- 6 <sup>3</sup> / <sub>4</sub>	5353	10- 3 <sup>1</sup> / <sub>8</sub>	3127	See Note 6
A6*	A6*	19- 8	5994	19- 6 <sup>3</sup> / <sub>4</sub>	5962	19- 6 <sup>3</sup> / <sub>4</sub>	5962	10- 3 <sup>1</sup> / <sub>8</sub>	3127	
A4*	B4*	17- 8	5385	17- 7 <sup>3</sup> / <sub>8</sub>	5369	17- 7 <sup>3</sup> / <sub>8</sub>	5369	10- 8 <sup>1</sup> / <sub>2</sub>	3264	
A6*	B6*	19- 8	5994	19- 7 <sup>3</sup> / <sub>8</sub>	5978	19- 7 <sup>3</sup> / <sub>8</sub>	5978	10- 8 <sup>1</sup> / <sub>2</sub>	3264	
B6*	C6*	20- 0	6096	19- 11 <sup>1</sup> / <sub>8</sub>	6074	19- 9	6120	12- 0 <sup>5</sup> / <sub>8</sub>	3674	
B8*	C8*	22- 0	6096	21- 11 <sup>1</sup> / <sub>8</sub>	6684	21- 9	6629	12- 5 <sup>1</sup> / <sub>2</sub>	3797	
C6*	C6*	20- 4 <sup>1</sup> / <sub>4</sub>	6204	19- 11 <sup>1</sup> / <sub>8</sub>	6074	19- 11 <sup>3</sup> / <sub>4</sub>	6090	12- 5 <sup>1</sup> / <sub>2</sub>	3797	
C6*	D6*	20- 4 <sup>1</sup> / <sub>4</sub>	6204	20- 0	6096	20- 0 <sup>1</sup> / <sub>2</sub>	6109	13- 2	4013	
C8*	D8*	20- 0	6096	21- 11 <sup>1</sup> / <sub>8</sub>	6684	21- 9	6629	13- 2	4013	

\* Assumes both cooler and condenser nozzles on same end of chiller.

**NOTES:**

- Service access should be provided per American Society of Heating, Refrigerating, and Air-Conditioning Engineers (ASHRAE) 15, latest edition, National Fire Protection Association (NFPA) 70, and local safety code.
- Allow at least 5 ft (1524 mm) overhead clearance for service rigging.
- Dimensions are approximate. Certified drawings available upon request.
- 'A' length dimensions shown are for standard 150 psig (1034 kPa) design and flanged connections.
- Table contains heat exchanger dimensions for largest type shown.
- 19XR heights can vary depending on the configuration. Check 19XR certified drawings for height information.

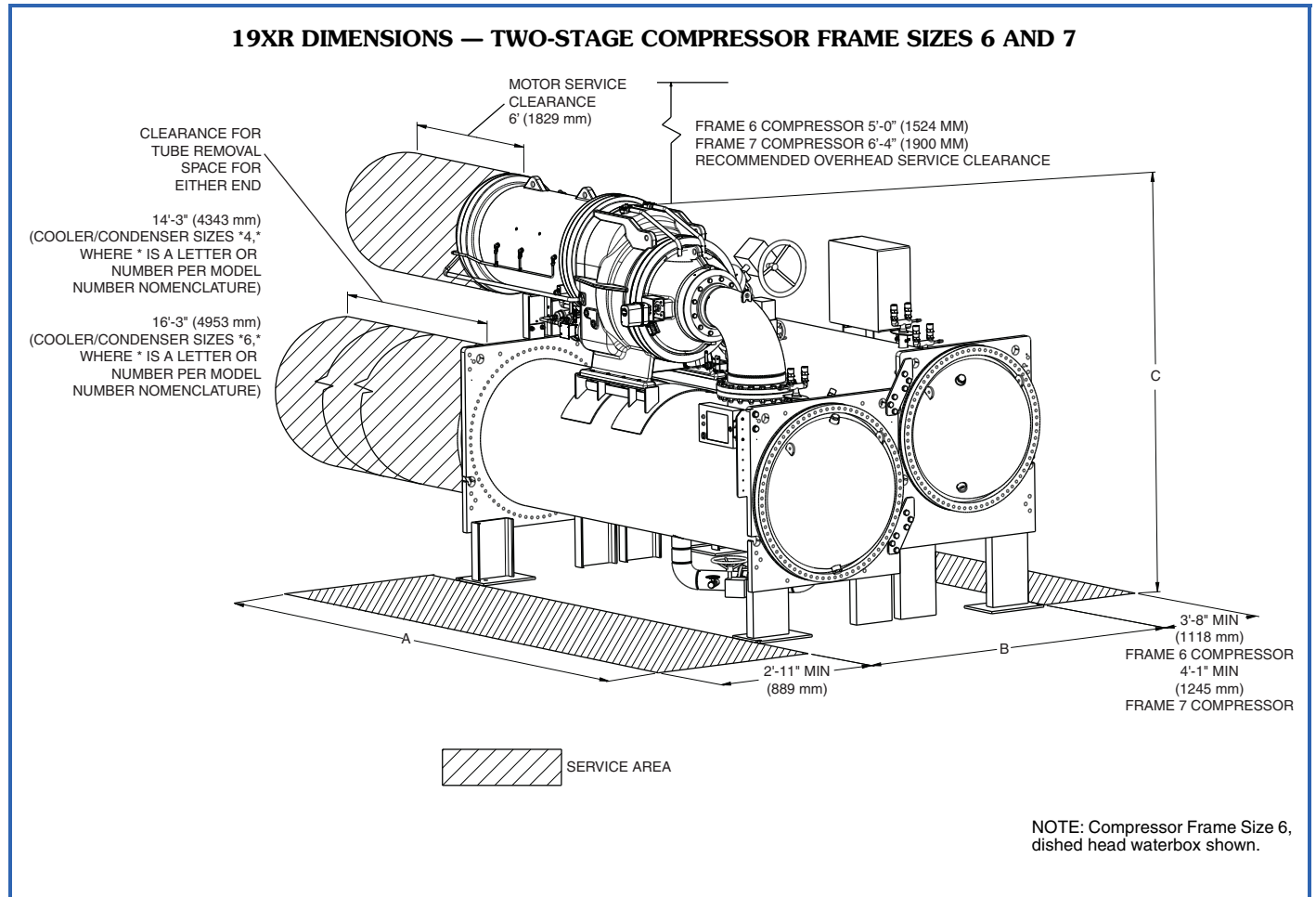

# Dimensions (cont)



## 19XR DIMENSIONS — TWO-STAGE COMPRESSOR FRAME SIZES 6 AND 7 (150 PSIG MARINE WATERBOX)

COOLER HEAT EXCHANGER SIZE	CONDENSER HEAT EXCHANGER SIZE	A (LENGTH, MARINE WATERBOX)						19XR B WIDTH		19XR C HEIGHT
		1-Pass		2-Pass		3-Pass		ft-in.	mm	
		ft-in.	mm	ft-in.	mm	ft-in.	mm			
A4*	A4*	23- 1 <sup>3</sup> / <sub>4</sub>	7055	21- 8 <sup>1</sup> / <sub>2</sub>	6617	20- 11	6375	10- 6 <sup>3</sup> / <sub>8</sub>	3210	See Note 6
A6*	A6*	25- 1 <sup>3</sup> / <sub>4</sub>	7665	23- 8 <sup>1</sup> / <sub>2</sub>	7226	22- 11	6985	10- 6 <sup>3</sup> / <sub>8</sub>	3210	
A4*	B4*	23- 1 <sup>3</sup> / <sub>4</sub>	7055	22- 1 <sup>3</sup> / <sub>4</sub>	6750	21- 1 <sup>3</sup> / <sub>4</sub>	6446	11- 0 <sup>1</sup> / <sub>8</sub>	3356	
A6*	B6*	25- 1 <sup>3</sup> / <sub>4</sub>	7665	24- 1 <sup>3</sup> / <sub>4</sub>	7360	23- 1 <sup>3</sup> / <sub>4</sub>	7055	11- 0 <sup>1</sup> / <sub>8</sub>	3356	
B6*	C6*	26- 6 <sup>3</sup> / <sub>4</sub>	8097	25- 2 <sup>1</sup> / <sub>2</sub>	7680	24- 2 <sup>3</sup> / <sub>4</sub>	7385	12- 3 <sup>7</sup> / <sub>8</sub>	3756	
B8*	C8*	28- 6 <sup>3</sup> / <sub>4</sub>	8706	27- 2 <sup>1</sup> / <sub>2</sub>	8293	26- 2 <sup>3</sup> / <sub>4</sub>	7994	12- 10 <sup>3</sup> / <sub>8</sub>	3921	
C6*	C6*	26- 6 <sup>3</sup> / <sub>4</sub>	8097	25- 4 <sup>7</sup> / <sub>8</sub>	7744	24- 2 <sup>3</sup> / <sub>4</sub>	8097	12- 3 <sup>7</sup> / <sub>8</sub>	3756	
C6*	D6*	26- 11	8204	25- 7 <sup>1</sup> / <sub>8</sub>	25705	24- 7	7493	13- 6 <sup>5</sup> / <sub>8</sub>	4131	
C8*	D8*	28- 6 <sup>3</sup> / <sub>4</sub>	8706	27- 2 <sup>1</sup> / <sub>2</sub>	8293	26- 2 <sup>3</sup> / <sub>4</sub>	7994	13- 6 <sup>5</sup> / <sub>8</sub>	4131	

\* Assumes both cooler and condenser nozzles on same end of chiller.

**NOTES:**

- Service access should be provided per American Society of Heating, Refrigerating, and Air-Conditioning Engineers (ASHRAE) 15, latest edition, National Fire Protection Association (NFPA) 70, and local safety code.
- Allow at least 5 ft (1524 mm) overhead clearance for service rigging.
- Dimensions are approximate. Certified drawings available upon request.
- 'A' length dimensions shown are for standard 150 psig (1034 kPa) design and flanged connections.
- Table contains largest of all configurations of the type shown.
- 19XR heights can vary depending on the configuration. Check 19XR certified drawings for height information.

## 19XR DIMENSIONS — TWO-STAGE COMPRESSOR FRAME SIZES 6 AND 7 (300 PSIG ASME MARINE WATERBOX)

COOLER HEAT EXCHANGER SIZE	CONDENSER HEAT EXCHANGER SIZE	A (LENGTH, MARINE WATERBOX)						19XR B WIDTH		19XR C HEIGHT
		1-Pass		2-Pass		3-Pass		ft-in.	mm	
		ft-in.	mm	ft-in.	mm	ft-in.	mm			
A4*	A4*	21- 5 <sup>1</sup> / <sub>2</sub>	6541	20- 5	6223	19- 5 <sup>1</sup> / <sub>2</sub>	5931	10- 8 <sup>5</sup> / <sub>8</sub>	3267	See Note 6
A6*	A6*	23- 5 <sup>1</sup> / <sub>2</sub>	7150	22- 5	6833	21- 5 <sup>1</sup> / <sub>2</sub>	6541	10- 8 <sup>5</sup> / <sub>8</sub>	3267	
A4*	B4*	21- 5 <sup>1</sup> / <sub>2</sub>	6541	20- 7 <sup>1</sup> / <sub>2</sub>	6287	19- 5 <sup>1</sup> / <sub>2</sub>	5931	11- 2 <sup>3</sup> / <sub>8</sub>	3413	
A6*	B6*	23- 5 <sup>1</sup> / <sub>2</sub>	7150	22- 7 <sup>1</sup> / <sub>2</sub>	6287	21- 5 <sup>1</sup> / <sub>2</sub>	6541	11- 2 <sup>7</sup> / <sub>8</sub>	3426	
B6*	C6*	24- 5 <sup>3</sup> / <sub>4</sub>	7462	23- 1 <sup>3</sup> / <sub>4</sub>	7055	22- 1 <sup>3</sup> / <sub>4</sub>	6750	12- 6 <sup>1</sup> / <sub>8</sub>	3813	
C6*	C6*	24- 5 <sup>3</sup> / <sub>4</sub>	7462	23- 2 <sup>1</sup> / <sub>2</sub>	7074	22- 1 <sup>3</sup> / <sub>4</sub>	6750	13- 0 <sup>7</sup> / <sub>8</sub>	3884	
B8*	C8*	26- 5 <sup>3</sup> / <sub>4</sub>	8071	25- 1 <sup>3</sup> / <sub>4</sub>	7664	24- 1 <sup>3</sup> / <sub>4</sub>	7360	12- 6 <sup>1</sup> / <sub>8</sub>	3813	
C6*	D6*	24- 7 <sup>3</sup> / <sub>4</sub>	7512	23- 3 <sup>1</sup> / <sub>2</sub>	7099	22- 3 <sup>3</sup> / <sub>4</sub>	6801	13- 9 <sup>1</sup> / <sub>2</sub>	4204	
C8*	D8*	26- 5 <sup>3</sup> / <sub>4</sub>	8071	25- 1 <sup>3</sup> / <sub>4</sub>	7664	24- 1 <sup>3</sup> / <sub>4</sub>	7360	13- 9 <sup>1</sup> / <sub>2</sub>	4204	

\* Assumes both cooler and condenser nozzles on same end of chiller.

**NOTES:**

- Service access should be provided per American Society of Heating, Refrigerating, and Air-Conditioning Engineers (ASHRAE) 15, latest edition, National Fire Protection Association (NFPA) 70, and local safety code.
- Allow at least 5 ft (1524 mm) overhead clearance for service rigging.
- Dimensions are approximate. Certified drawings available upon request.
- 'A' length dimensions shown are for standard 150 psig (1034 kPa) design and flanged connections.
- Table contains largest of all configurations of the type shown.
- 19XR heights can vary depending on the configuration. Check 19XR certified drawings for height information.

### NOZZLE SIZE

HEAT EXCHANGER FRAME SIZE	NOZZLE SIZE (IN.) (NOMINAL PIPE SIZE)					
	Cooler			Condenser		
	1-Pass	2-Pass	3-Pass	1-Pass	2-Pass	3-Pass
1	8	6	6	8	6	6
2	10	8	6	10	8	6
3	10	8	6	10	8	6
4	10	8	6	10	8	6
5	10	8	6	10	10	8
6	10	10	8	10	10	8
7	14	12	10	14	12	12
8	14	14	12	14	18	12
A	20	16	12	20	16	14
B	20	18	14	20	18	14
C	20	18	14	24	20	16
D	—	—	—	24	20	16

# Selection procedure



## Compressor motor controllers

Compressor motors, as well as controls and accessories, require the use of starting equipment systems specifically designed for 19XR or 19XRV chillers. Consult your local Carrier representative regarding design information for the selection of starters.

## Capacitors/power factors

Power factor considerations may indicate use of capacitors. Properly sized capacitors improve power factors, especially at part load. The 19XR, XRV Computer Selection program can select the proper capacitor size required for the application.

# Electrical data / ratings

### AUXILIARY RATINGS (OIL PUMP) (3 PHASE, 50/60 HZ)

ITEM	AVERAGE KW	MIN/MAX MOTOR VOLTAGE/FREQUENCY V-PH-HZ	FLA	LRA	SEALED KVA	INRUSH KVA
OIL PUMP	1.35	200/240-3-60	5.15	24.5	1.96	9.34
	1.30	380/460-3-60	2.55	13.1	1.86	9.53
	1.37	507/619-3-60	2.54	25.0	2.48	24.38
	1.50	220/240-3-50	5.74	28.0	2.29	11.15
	1.50	346/440-3-50	3.07	12.2	2.09	8.30

LEGEND

FLA — Full Load Amps  
LRA — Locked Rotor Amps

NOTE: FLA = Sealed kva • 1000/√3 • volts

LRA = Inrush kva • 1000/√3 • volts

### AUXILIARY RATINGS (CONTROLS, OIL SUMP HEATER)

ITEM	POWER SUPPLY	SEALED KVA	AVERAGE WATTS
CONTROLS	24-vac	0.2	200
OIL SUMP HEATER V-PH-HZ	115 V or 230 V, Single Phase, 50 or 60 Hz	—	1500 (Frame 2 Compressor)
			1800 (Frame 3,4 Compressor)
			2200 (Frame 5, E Compressor)
	1800 (Frame 4 SRD Only)		
	3000 (Frame 6 Compressor)		
	3500 (Frame 7 Compressor)		
	380 V, 50 or 60 Hz; 460 V, 50 or 60 Hz	—	

LEGEND

SRD — Split Ring Diffuser

NOTES:

- Oil sump heater only operates when the compressor is off.
- Power to oil heater/controls must be on circuits that can provide continuous service when the compressor is disconnected.

### LOW VOLTAGE POWER (CONTROL PANEL) (3 PHASE, 50/60 HZ)

FRAME SIZE	MCA	MOCP
XR6 380V	16	20
XR6 460V	13.2	15
XR7 380V	17.7	20
XR7 460V	14.6	20

LEGEND

MCA — Minimum Circuit Amps  
MOCP — Maximum Overcurrent Protection

## Microprocessor controls

Microprocessor controls provide the safety, interlock, capacity control, and indications necessary to operate the chiller in a safe and efficient manner.

### Control system

The microprocessor control on each Carrier centrifugal system is factory mounted, wired, and tested to ensure machine protection and efficient capacity control. In addition, the program logic ensures proper starting, stopping, and recycling of the chiller and provides a communication link to the Carrier Comfort Network® (CCN) system.

### Features

#### Control system

- Component test and diagnostic check
- Programmable recycle allows chiller to recycle at optimum loads for decreased operating costs
- Menu-driven keypad interface for status display, set point control, and system configuration
- CCN compatible
- Primary and secondary status messages
- Individual start/stop schedules for local and CCN operation modes
- Recall of up to 25 alarm/alert messages with diagnostic help
- Two-chiller lead/lag with third chiller standby is standard
- Optional soft stop unloading closes guide vanes to unload the motor to the configured amperage level prior to stopping
- Languages pre-programmed at factory for English and Chinese
- An ILT (international language translator) is available for conversion of extended ASCII characters

#### Safety cutouts

- Bearing oil high temperature\*
- Motor high temperature\*†
- Refrigerant (condenser) high pressure\*†
- Refrigerant (cooler) low temperature\*†
- Lube oil low pressure
- Compressor (refrigerant) discharge temperature\*
- Under voltage\*\*
- Over voltage\*\*
- Oil pump motor overload
- Motor overload†
- Motor acceleration time
- Intermittent power loss

- Compressor starter faults
- Compressor surge protection\*
- Low level ground fault
  - Low voltage — phase to phase and phase to ground
  - Medium voltage — phase to phase and phase to ground
- Cooler freeze protection

### Capacity control

- Leaving chilled water control
- Entering chilled water control
- Ice build control
- Soft loading control by temperature or load ramping
- Guide vane actuator module
- Hot gas bypass valve
- Power (demand) limiter
- Auto. chilled water reset
- Variable chiller optimization (VDO) (available on compressor frame sizes 4 and 5 with diffuser control enabled)
- Compressor surge prevention control

### Interlocks

- Manual/automatic remote start
- Starting/stopping sequence:
  - Pre-lube/post-lube
  - Pre-flow/post-flow
- Compressor starter run interlock
- Pre-start check of safeties and alerts
- Low chilled water (load) recycle
- Monitor/number compressor starts and run hours
- Manual reset of safeties

### Indications

- Chiller operating status message
- Power-on
- Pre-start diagnostic check
- Compressor motor amps
- Pre-alarm alert††
- Alarm
- Contact for remote alarm
- Safety shutdown messages
- Elapsed time (hours of operation)
- Chiller input kW

\* These can be configured by user to provide alert indication at user-defined limit.

† Override protection: Causes compressor to first unload and then, if necessary, shut down.

\*\* Will not require manual reset or cause an alarm if auto-restart after power failure is enabled.

†† By display code only.

## 19XR CHILLER WITH FREE-STANDING STARTER OR VFD

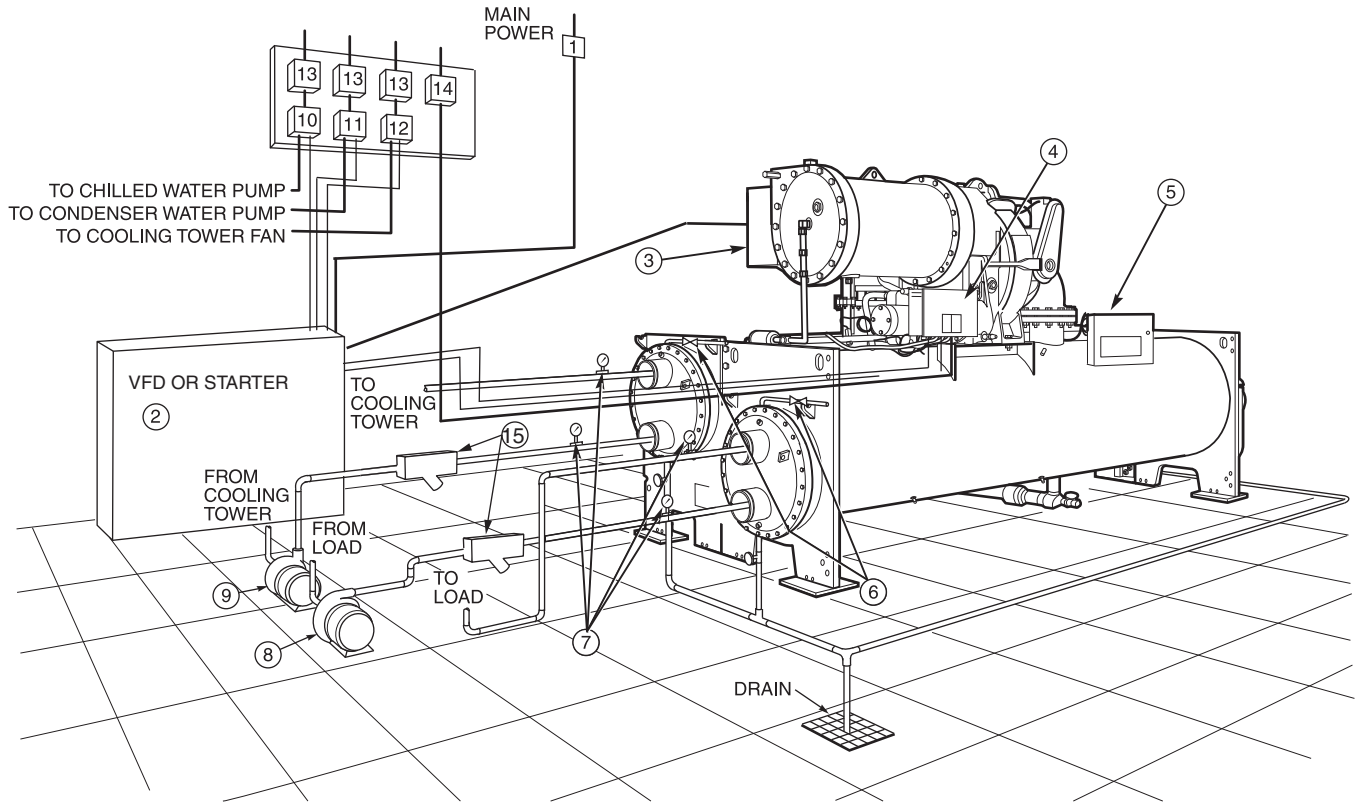

### LEGEND

- 1 — Disconnect
  - 2 — Free-standing Compressor Motor Starter or VFD
  - 3 — Compressor Motor Terminal Box
  - 4 — Power Panel
  - 5 — Control Panel
  - 6 — Vents
  - 7 — Pressure Gages
  - 8 — Chilled Water Pump
  - 9 — Condenser Water Pump
  - 10 — Chilled Water Pump Starter
  - 11 — Condensing Water Pump Starter
  - 12 — Cooling Tower Fan Starter (Low Fan, High Fan)
  - 13 — Disconnect
  - 14 — Oil Pump Disconnect (See Note 4)
  - 15 — Strainers
- Piping  
 Control Wiring  
 Power Wiring

### NOTES:

1. Wiring and piping shown are for general point-of-connection only and are not intended to show details for a specific installation. Certified field wiring and dimensional diagrams are available on request.
2. All wiring must comply with applicable codes.
3. Wiring not shown for optional devices such as:
  - Remote Start/Stop
  - Remote Alarms
  - Optional Safety Device
  - 4 to 20 mA Resets
  - Optional Remote Sensors
4. Oil pump disconnect may be located within the enclosure of Item 2 — Free-standing Compressor Motor Starter or VFD.
5. **IMPORTANT:** Carrier suggests that a structural engineer be consulted if transmission of vibrations from mechanical equipment is of concern.
6. Isolation valves are recommended on the cooler and condenser piping to each chiller for service.
7. Operating environment — Chiller should be installed in an indoor environment where the ambient temperature is 40 to 104°F (4 to 40°C) with a relative humidity (non-condensing) of 95% or less. To ensure that electrical components operate properly, do not locate the chiller in an area exposed to dust, dirt, corrosive fumes, or excessive heat and humidity.

## 19XR CHILLER WITH OPTIONAL UNIT-MOUNTED STARTER OR VFD

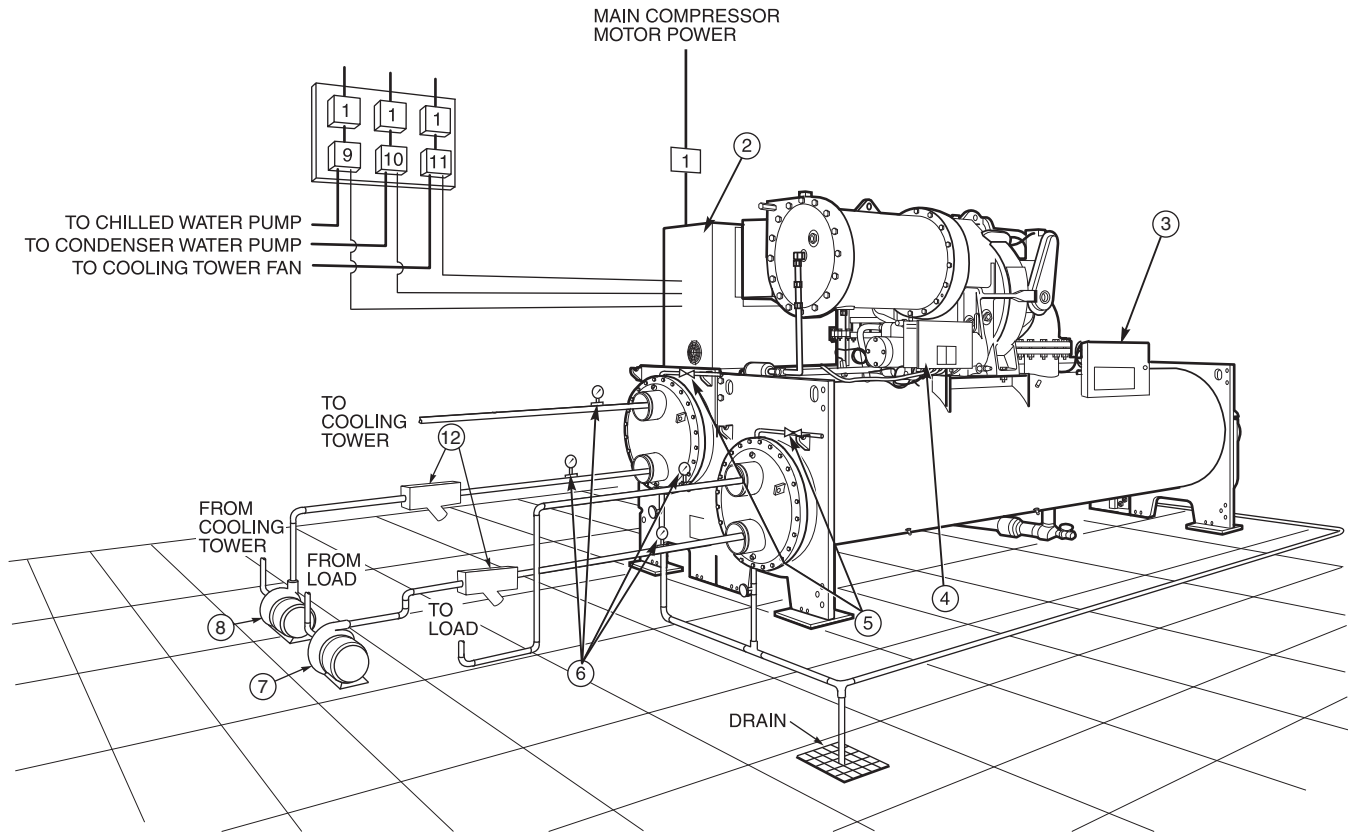

### LEGEND

- 1 — Disconnect
  - 2 — Unit-Mounted Starter or VFD
  - 3 — Control Panel
  - 4 — Power Panel
  - 5 — Vents
  - 6 — Pressure Gages
  - 7 — Chilled Water Pump
  - 8 — Condenser Water Pump
  - 9 — Chilled Water Pump Starter
  - 10 — Condensing Water Pump Starter
  - 11 — Cooling Tower Fan Starter (Low Fan, High Fan)
  - 12 — Strainers
- Piping  
 Control Wiring  
 Power Wiring

### NOTES:

1. Wiring and piping shown are for general point-of-connection only and are not intended to show details for a specific installation. Certified field wiring and dimensional diagrams are available on request.
2. All wiring must comply with applicable codes.
3. Wiring not shown for optional devices such as:
  - Remote Start/Stop
  - Remote Alarms
  - Optional Safety Device
  - 4 to 20 mA Resets
  - Optional Remote Sensors
4. **IMPORTANT:** Carrier suggests that a structural engineer be consulted if transmission of vibrations from mechanical equipment is of concern.
5. Isolation valves are recommended on the cooler and condenser piping to each chiller for service.
6. Operating environment — Chiller should be installed in an indoor environment where the ambient temperature is 40 to 104°F (4 to 40°C) with a relative humidity (non-condensing) of 95% or less. To ensure that electrical components operate properly, do not locate the chiller in an area exposed to dust, dirt, corrosive fumes, or excessive heat and humidity.

## 19XR,XRV SINGLE-STAGE COMPRESSOR MACHINE FOOTPRINT

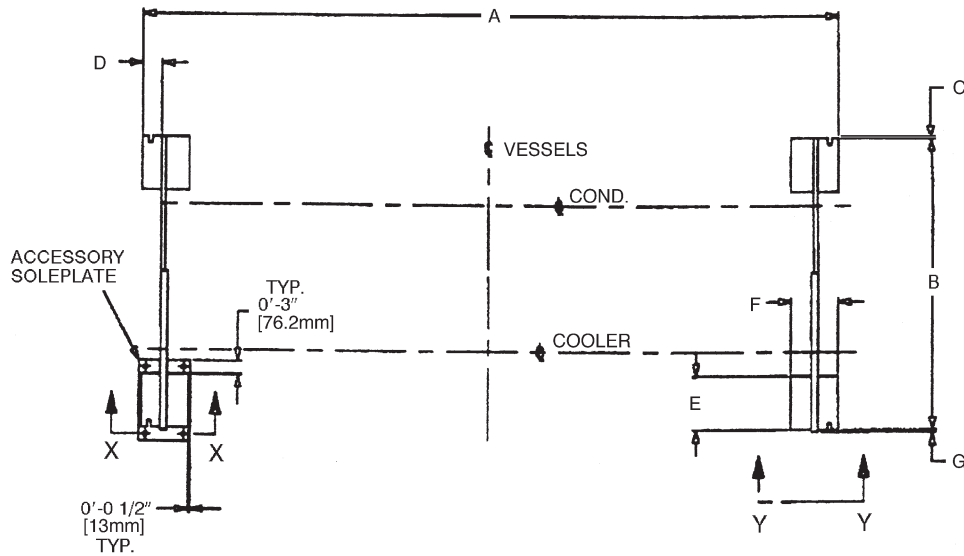

19XR,XRV HEAT EXCHANGER SIZE	DIMENSIONS													
	A		B		C		D		E		F		G	
	ft-in.	mm	ft-in.	mm	ft-in.	mm	ft-in.	mm	ft-in.	mm	ft-in.	mm	ft-in.	mm
10-12	10- 7 <sup>1</sup> / <sub>4</sub>	3232	4-10 <sup>1</sup> / <sub>4</sub>	1480	0-1	25	0-3 <sup>5</sup> / <sub>8</sub>	92	1-3 <sup>1</sup> / <sub>4</sub>	382	0-9	229	0-1 <sup>1</sup> / <sub>2</sub>	13
15-17	12-10 <sup>3</sup> / <sub>4</sub>	3931	4-10 <sup>1</sup> / <sub>4</sub>	1480	0-1	25	0-3 <sup>5</sup> / <sub>8</sub>	92	1-3 <sup>1</sup> / <sub>4</sub>	382	0-9	229	0-1 <sup>1</sup> / <sub>2</sub>	13
20-22	10- 7 <sup>1</sup> / <sub>4</sub>	3232	5- 4 <sup>1</sup> / <sub>4</sub>	1632	0-1	25	0-3 <sup>5</sup> / <sub>8</sub>	92	1-3 <sup>1</sup> / <sub>4</sub>	382	0-9	229	0-1 <sup>1</sup> / <sub>2</sub>	13
30-32	12-10 <sup>3</sup> / <sub>4</sub>	3931	5- 4 <sup>1</sup> / <sub>4</sub>	1632	0	0	0-3 <sup>5</sup> / <sub>8</sub>	92	1-3 <sup>1</sup> / <sub>4</sub>	382	0-9	229	0-1 <sup>1</sup> / <sub>2</sub>	13
35-37	14- 7 <sup>1</sup> / <sub>4</sub>	4451	5- 4 <sup>1</sup> / <sub>4</sub>	1632	0	0	0-3 <sup>5</sup> / <sub>8</sub>	92	1-3 <sup>1</sup> / <sub>4</sub>	382	0-9	229	0-1 <sup>1</sup> / <sub>2</sub>	13
40-42	12-10 <sup>3</sup> / <sub>4</sub>	3931	6- 0	1829	0-1 <sup>1</sup> / <sub>2</sub>	38	0-3 <sup>5</sup> / <sub>8</sub>	92	1-3 <sup>1</sup> / <sub>4</sub>	382	0-9	229	0-1 <sup>1</sup> / <sub>2</sub>	13
45-47	14- 7 <sup>1</sup> / <sub>4</sub>	4451	6- 0	1829	0-1 <sup>1</sup> / <sub>2</sub>	38	0-3 <sup>5</sup> / <sub>8</sub>	92	1-3 <sup>1</sup> / <sub>4</sub>	382	0-9	229	0-1 <sup>1</sup> / <sub>2</sub>	13
50-54, 5A-5C, 5K-5R	12-10 <sup>3</sup> / <sub>4</sub>	3931	6- 5 <sup>1</sup> / <sub>2</sub>	1968	0- 1 <sup>1</sup> / <sub>2</sub>	13	0-3 <sup>5</sup> / <sub>8</sub>	92	1-3 <sup>1</sup> / <sub>4</sub>	382	0-9	229	0-1 <sup>1</sup> / <sub>2</sub>	13
55-59, 5F-5H, 5T-5Z	14- 7 <sup>1</sup> / <sub>4</sub>	4451	6- 5 <sup>1</sup> / <sub>2</sub>	1968	0- 1 <sup>1</sup> / <sub>2</sub>	13	0-3 <sup>5</sup> / <sub>8</sub>	92	1-3 <sup>1</sup> / <sub>4</sub>	382	0-9	229	0-1 <sup>1</sup> / <sub>2</sub>	13
60-64, 6K-6R	12-10 <sup>3</sup> / <sub>4</sub>	3931	6- 9 <sup>1</sup> / <sub>2</sub>	2070	0- 1 <sup>1</sup> / <sub>2</sub>	13	0-3 <sup>5</sup> / <sub>8</sub>	92	1-3 <sup>1</sup> / <sub>4</sub>	382	0-9	229	0-1 <sup>1</sup> / <sub>2</sub>	13
65-69, 6T-6Z	14- 7 <sup>1</sup> / <sub>4</sub>	4451	6- 9 <sup>1</sup> / <sub>2</sub>	2070	0- 1 <sup>1</sup> / <sub>2</sub>	13	0-3 <sup>5</sup> / <sub>8</sub>	92	1-3 <sup>1</sup> / <sub>4</sub>	382	0-9	229	0-1 <sup>1</sup> / <sub>2</sub>	13
70-74, 7K-7R	15- 1 <sup>7</sup> / <sub>8</sub>	4620	7-10 <sup>1</sup> / <sub>2</sub>	2400	0- 1 <sup>1</sup> / <sub>4</sub>	6	0-6 <sup>15</sup> / <sub>16</sub>	176	1-10	559	1-4	406	0-3 <sup>3</sup> / <sub>4</sub>	19
75-79, 7T-7Z	17- 1 <sup>7</sup> / <sub>8</sub>	5229	7-10 <sup>1</sup> / <sub>2</sub>	2400	0- 1 <sup>1</sup> / <sub>4</sub>	6	0-6 <sup>15</sup> / <sub>16</sub>	176	1-10	559	1-4	406	0-3 <sup>3</sup> / <sub>4</sub>	19
80-84, 8K-8R	15- 1 <sup>7</sup> / <sub>8</sub>	4620	8- 9 <sup>3</sup> / <sub>4</sub>	2686	0-1 <sup>15</sup> / <sub>16</sub>	24	0-6 <sup>15</sup> / <sub>16</sub>	176	1-10	559	1-4	406	0-1 <sup>1</sup> / <sub>16</sub>	2
85-89, 8T-8Z	17- 1 <sup>7</sup> / <sub>8</sub>	5229	8- 9 <sup>3</sup> / <sub>4</sub>	2686	0-1 <sup>15</sup> / <sub>16</sub>	24	0-6 <sup>15</sup> / <sub>16</sub>	176	1-10	559	1-4	406	0-1 <sup>1</sup> / <sub>16</sub>	2

**NOTES:**

1. X-X dimension refers to accessory soleplate. See page 65.
2. Y-Y dimension refers to standard support plate. See page 65.



## 19XR TWO-STAGE COMPRESSORS FRAME SIZES 6 AND 7 MACHINE FOOTPRINT

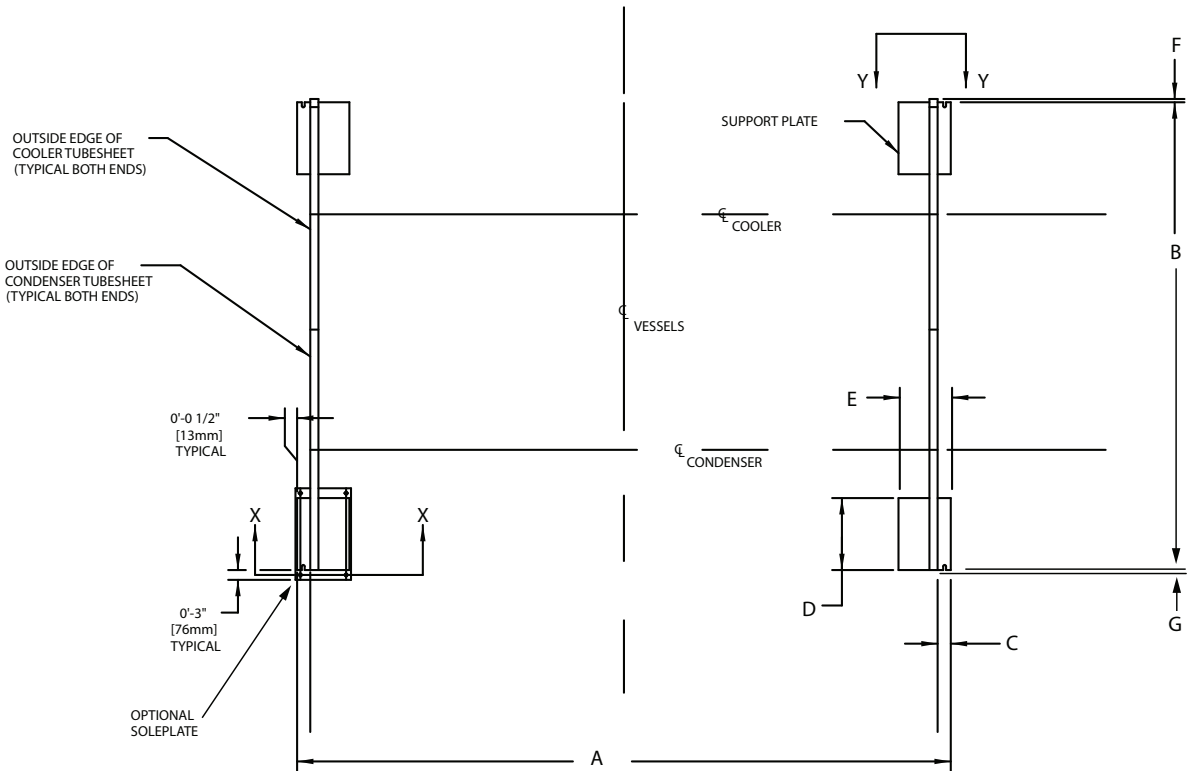

19XR HEAT EXCHANGER SIZE		DIMENSIONS													
		A		B		C		D		E		F		G	
		ft-in.	mm	ft-in.	mm	ft-in.	mm	ft-in.	mm	ft-in.	mm	ft-in.	mm	ft-in.	mm
COOLER	CONDENSER														
A4	A4	14- 8 <sup>7</sup> / <sub>8</sub>	4492	10- 0 <sup>1</sup> / <sub>8</sub>	3051	0-4 <sup>7</sup> / <sub>16</sub>	113	1-10	559	1-4	406	—	—	—	—
	B4	14- 8 <sup>7</sup> / <sub>8</sub>	4492	10- 5 <sup>3</sup> / <sub>8</sub>	3177	0-4 <sup>7</sup> / <sub>16</sub>	113	1-10	559	1-4	406	—	—	—	—
A6	A6	16- 8 <sup>7</sup> / <sub>8</sub>	5102	10- 0 <sup>1</sup> / <sub>8</sub>	3051	0-4 <sup>7</sup> / <sub>16</sub>	113	1-10	559	1-4	406	—	—	—	—
	B6	16- 8 <sup>7</sup> / <sub>8</sub>	5102	10- 5 <sup>3</sup> / <sub>8</sub>	3177	0-4 <sup>7</sup> / <sub>16</sub>	113	1-10	559	1-4	406	—	—	—	—
B6	C6	16- 8	5080	11-11	3632	0-4	102	1-10	559	1-4	406	—	—	0-1	25
B8	C8	18- 8	5690	11-11	3632	0-4	102	1-10	559	1-4	406	—	—	0-1	25
C6	C6	16- 8	5080	12- 4 <sup>1</sup> / <sub>2</sub>	3662	0-4	102	1-10	559	1-4	406	—	—	0-1	25
	D6	16- 8	5080	13- 2	4013	0-4	102	1-10	559	1-4	406	—	—	—	—
C8	D8	18- 8	5690	13- 2	4013	0-4	102	1-10	559	1-4	406	—	—	—	—

**NOTES:**

1. X-X dimension refers to accessory soleplate. See page 65.
2. Y-Y dimension refers to standard support plate. See page 65.

## 19XR, XRV ISOLATION WITH ACCESSORY SOLEPLATE PACKAGE

### TYPICAL ISOLATION

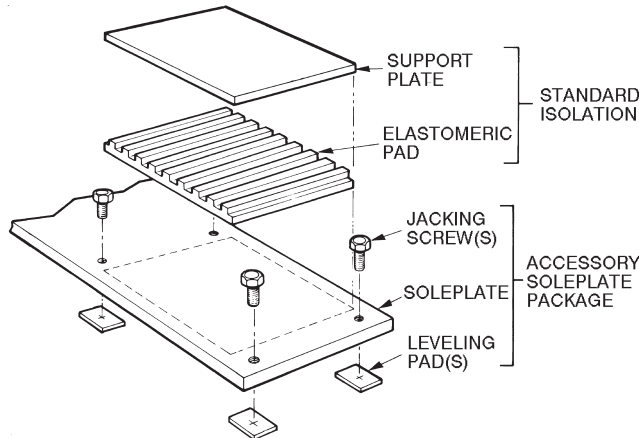

### STANDARD ISOLATION

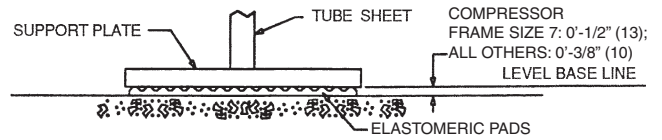

VIEW Y-Y

ISOLATION WITH STANDARD PACKAGE ONLY

NOTE: Isolation package includes 4 elastomeric pads.

### ACCESSORY SOLEPLATE DETAIL

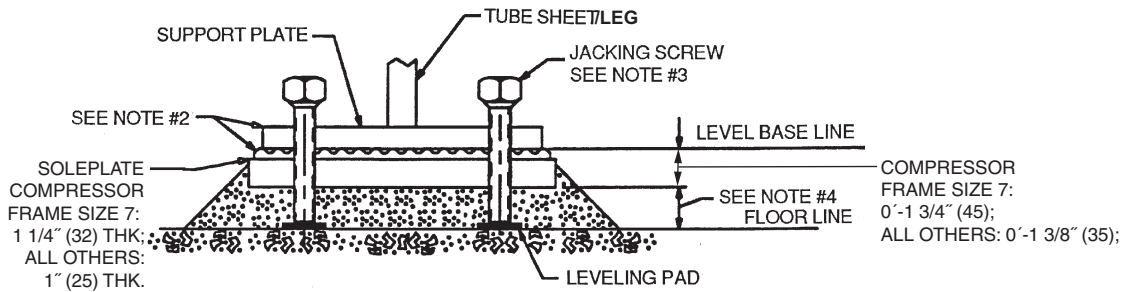

VIEW X-X

#### NOTES:

1. Dimensions in ( ) are in millimeters.
2. Accessory (Carrier-supplied, field-installed) soleplate package includes 4 soleplates, 16 jacking screws and leveling pads. Isolation package is also required.
3. Jacking screws to be removed after grout has set.
4. Thickness of grout will vary, depending on the amount necessary to level chiller. Use only pre-mixed non-shrinking grout, Ceilcote 748 OR Embeco 636 Plus Grout, 0'-1 1/2" (38.1) to 0'-2 1/4" (57) thick.

## 19XR,XRV NOZZLE ARRANGEMENTS NOZZLE-IN-HEAD WATERBOXES

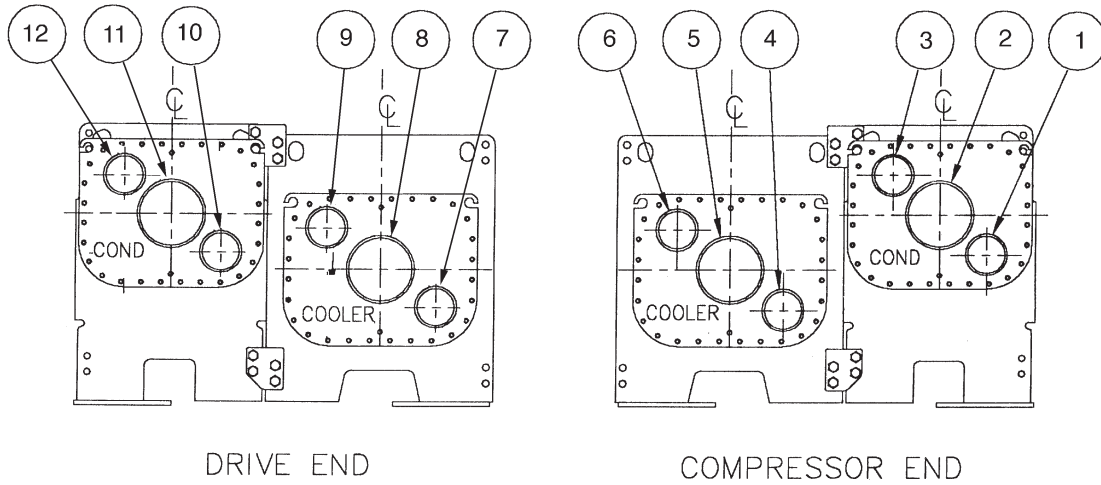

**FRAMES 1, 2, AND 3**

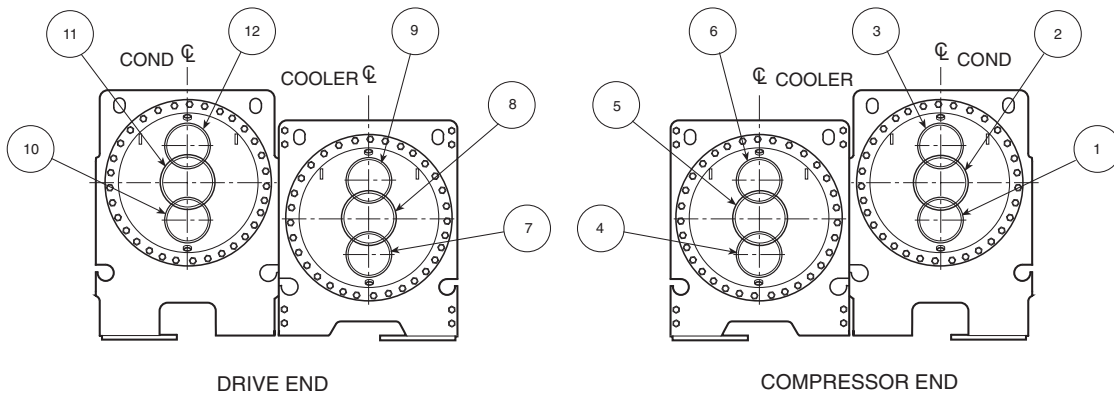

**FRAMES 4, 5, AND 6**

**19XR, XRV NOZZLE ARRANGEMENTS (CONT)  
NOZZLE-IN-HEAD WATERBOXES (CONT)**

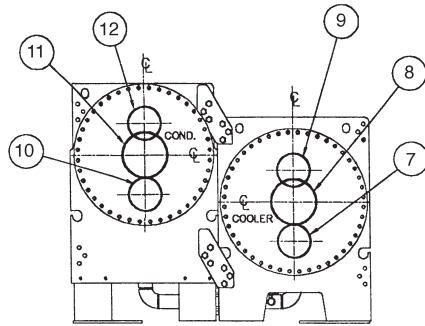

DRIVE END

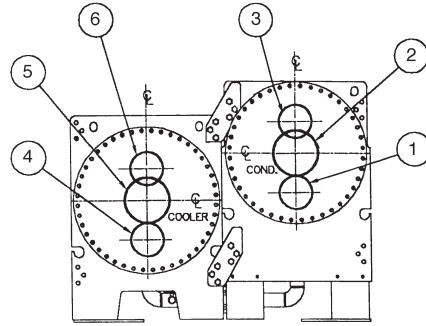

COMPRESSOR END

**FRAMES 7 AND 8**

**NOZZLE ARRANGEMENT CODES FOR 19XR NOZZLE-IN-HEAD WATERBOXES FRAMES 1-8**

COOLER WATERBOXES			
PASS	IN	OUT	ARRANGEMENT CODE*
1	8	5	A
	5	8	B
2	7	9	C
	4	6	D
3	7	6	E
	4	9	F

CONDENSER WATERBOXES			
PASS	IN	OUT	ARRANGEMENT CODE*
1	11	2	P
	2	11	Q
2	10	12	R
	1	3	S
3	10	3	T
	1	12	U

\* Refer to certified drawings.

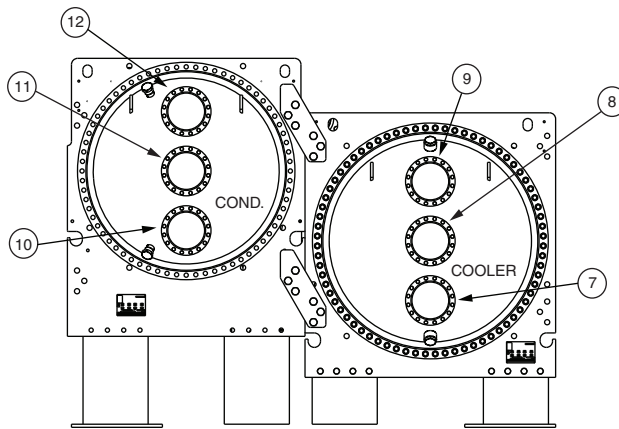

MOTOR END

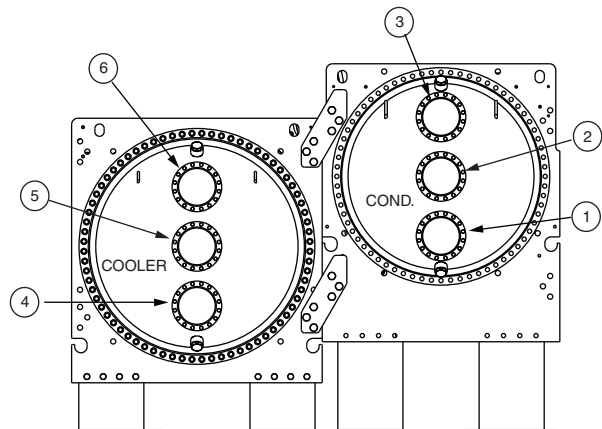

COMPRESSOR END

**19XR TWO-STAGE COMPRESSORS FRAME SIZES 6 AND 7 (HEAT EXCHANGER FRAMES A, B, C, AND D)**

**NOZZLE ARRANGEMENT CODES FOR 19XR TWO-STAGE COMPRESSORS FRAME SIZES 6 AND 7**

COOLER WATERBOXES			
PASS	IN	OUT	ARRANGEMENT CODE*
1†	8	5	A
	5	8	B
2	7	9	C
	4	6	D
3†	7	6	E
	4	9	F

CONDENSER WATERBOXES			
PASS	IN	OUT	ARRANGEMENT CODE*
1†	11	2	P
	2	11	Q
2	10	12	R
	1	3	S
3†	10	3	T
	1	12	U

\* Refer to certified drawings.

† One and 3 pass arrangements are available via special order only.

## 19XR,XRV NOZZLE ARRANGEMENTS (CONT) MARINE WATERBOXES

NOTE :  
COOLER 3-PASS NOZZLE @ 45°  
(NOT SHOWN) SIMILAR TO  
CONDENSER 2-PASS

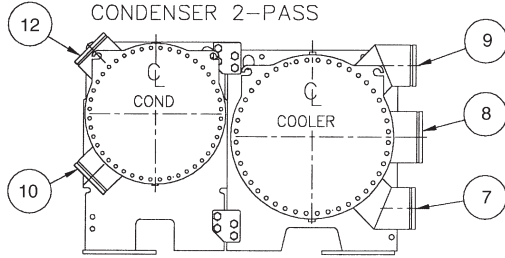

DRIVE END

NOTE :  
COOLER 3-PASS NOZZLE @ 45°  
(NOT SHOWN) SIMILAR TO  
CONDENSER 2-PASS

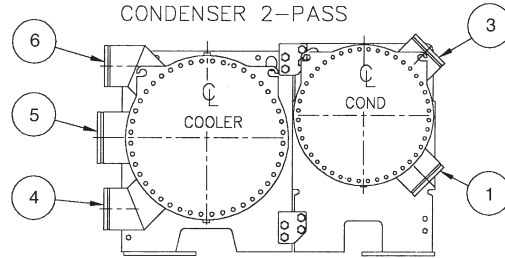

COMPRESSOR END

### FRAMES 2 AND 3†

†There is no Frame 1 marine waterbox.

### NOZZLE ARRANGEMENT CODES

PASS	COOLER WATERBOXES			CONDENSER WATERBOXES		
	IN	OUT	ARRANGEMENT CODE	IN	OUT	ARRANGEMENT CODE
1	8	5	A	—	—	—
	5	8	B	—	—	—
2	7	9	C	10	12	R
	4	6	D	1	3	S
3	7	6	E	—	—	—
	4	9	F	—	—	—

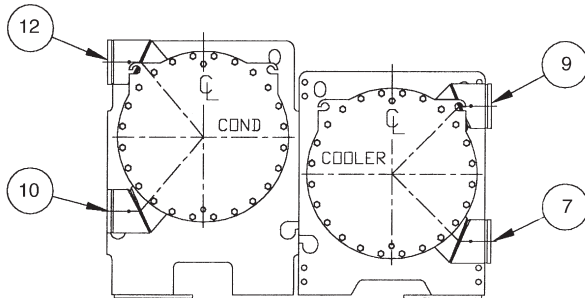

DRIVE END

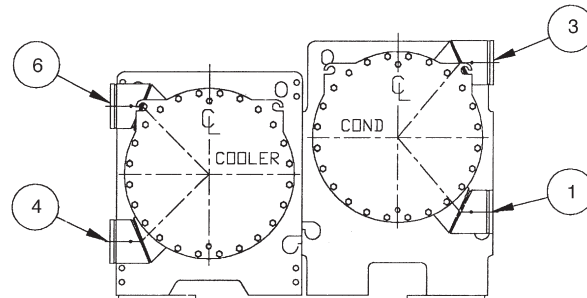

COMPRESSOR END

### FRAMES 4, 5, AND 6

### NOZZLE ARRANGEMENT CODES

PASS	COOLER WATERBOXES			CONDENSER WATERBOXES		
	IN	OUT	ARRANGEMENT CODE	IN	OUT	ARRANGEMENT CODE
1	9	6	A	—	—	—
	6	9	B	—	—	—
2	7	9	C	10	12	R
	4	6	D	1	3	S
3	7	6	E	—	—	—
	4	9	F	—	—	—

**19XR,XRV NOZZLE ARRANGEMENTS (CONT)  
MARINE WATERBOXES (CONT)**

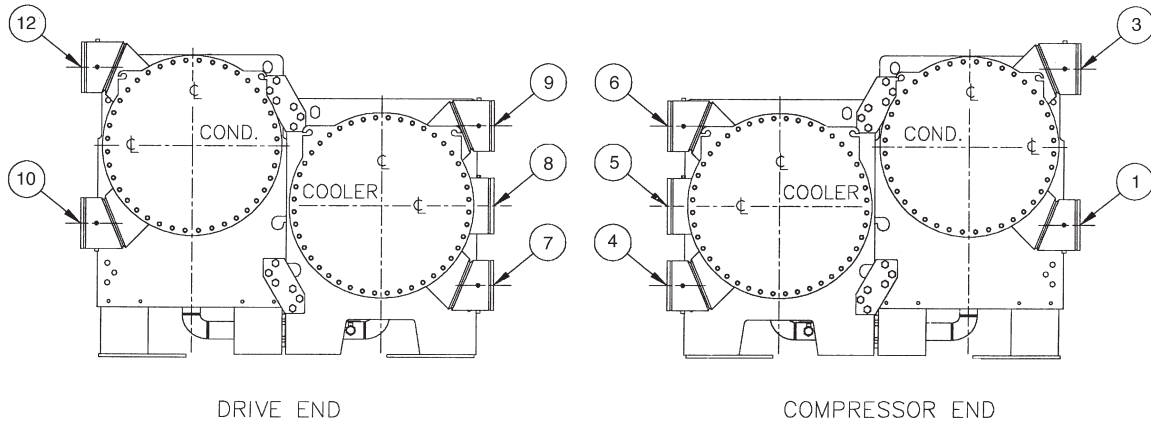

**FRAMES 7 AND 8  
NOZZLE ARRANGEMENT CODES**

PASS	COOLER WATERBOXES			CONDENSER WATERBOXES		
	IN	OUT	ARRANGEMENT CODE	IN	OUT	ARRANGEMENT CODE
1	8	5	A	—	—	—
	5	8	B	—	—	—
2	7	9	C	10	12	R
	4	6	D	1	3	S
3	7	6	E	—	—	—
	4	9	F	—	—	—

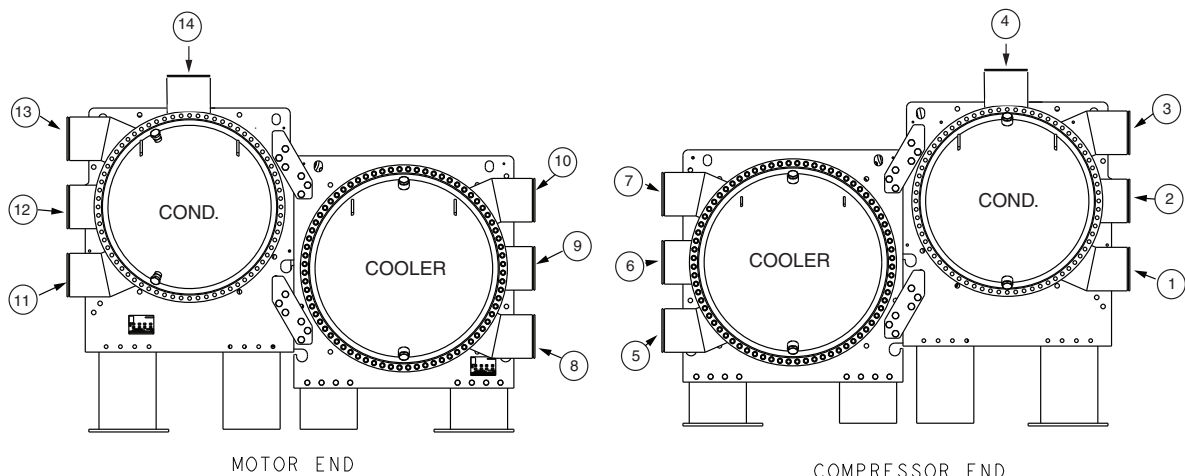

**19XR TWO-STAGE COMPRESSORS FRAME SIZES 6 AND 7 FRAMES A, B, C, AND D  
NOZZLE ARRANGEMENT CODES**

COOLER MARINE WATERBOXES			
PASS	IN	OUT	ARRANGEMENT CODE
1	9	6	A
	6	9	B
2	8	10	C
	5	7	D
3	8	7	E
	5	10	F

CONDENSER MARINE WATERBOXES			
PASS	IN	OUT	ARRANGEMENT CODE
1	12	2	P
	2	12	Q
2	11	13	R
	1	3	S
	11	14	V
3	1	4	W
	11	3	T
	1	13	U

## RELIEF VALVE LOCATIONS

LOCATION	FRAME SIZE	RELIEF VALVE OUTLET SIZE
COOLER	1-2	1-in. NPT FEMALE CONNECTOR
	3-8	1 1/4-in. NPT FEMALE CONNECTOR
	Two-Stage 6—A	1 1/4-in. NPT FEMALE CONNECTOR
	Two-Stage 7—B	1 1/4-in. NPT FEMALE CONNECTOR
	Two-Stage 7—C	1 1/4-in. NPT FEMALE CONNECTOR
CONDENSER	1-2	1-in. NPT FEMALE CONNECTOR
	3-8	1 1/4-in. NPT FEMALE CONNECTOR
	Two-Stage 6—A	1 1/4-in. NPT FEMALE CONNECTOR
	Two-Stage 6—B	1 1/4-in. NPT FEMALE CONNECTOR
	Two-Stage 7—C	1 1/4-in. NPT FEMALE CONNECTOR
	Two-Stage 7—D	1 1/4-in. NPT FEMALE CONNECTOR
OPTIONAL STORAGE TANK	N/A	1-in. NPT FEMALE CONNECTOR

NOTE: All valves relieve at 185 psig (1275 kPa).

## RELIEF VALVE ARRANGEMENT, SINGLE-STAGE COMPRESSORS AND TWO-STAGE COMPRESSOR FRAME SIZE E (REFER TO PAGE 72)

HEAT EXCHANGER FRAME SIZE	COMPRESSOR FRAME SIZE	WITH/WITHOUT DISCHARGE ISOLATION VALVE	COOLER VIEW	CONDENSER VIEW	COOLER NO. VALVES	CONDENSER NO. VALVES
1, 2	2	With Optional Isolation Valve	A	E	1	2
		Without Optional Isolation Valve	C	E	2	2
3	2	With Optional Isolation Valve	A	E	1	2
		Without Optional Isolation Valve	C	E	2	2
	3	With Optional Isolation Valve	A	E	1	2
		Without Optional Isolation Valve	C	E	2	2
4	3	With Optional Isolation Valve	A	E	1	2
		Without Optional Isolation Valve	C	E	2	2
5	3	With Optional Isolation Valve	A	E	1	2
		Without Optional Isolation Valve	C	E	2	2
	4	With Optional Isolation Valve	A	E	1	2
		Without Optional Isolation Valve	C	E	2	2
6	4	With Optional Isolation Valve	A	E	1	2
		Without Optional Isolation Valve	C	E	2	2
7, 8	4, 5, E	With Optional Isolation Valve	B	F	2	4
		Without Optional Isolation Valve	D	F	4	4



**RELIEF VALVE ARRANGEMENT, TWO-STAGE COMPRESSOR FRAME SIZE 6 (REFER TO PAGE 73)**

COOLER HEAT EXCHANGER FRAME SIZE*	CONDENSER HEAT EXCHANGER FRAME SIZE*	WITH/WITHOUT DISCHARGE ISOLATION VALVE	VIEW CODE	COOLER NO. VALVES	CONDENSER NO. VALVES
<b>A4</b>	<b>A4</b>	With Optional Isolation Valve	G	2	4
		Without Optional Isolation Valve	H	4	4
	<b>B4</b>	With Optional Isolation Valve	G	2	4
		Without Optional Isolation Valve	H	4	4
<b>A6</b>	<b>A6</b>	With Optional Isolation Valve	G	2	4
		Without Optional Isolation Valve	H	4	4
	<b>B6</b>	With Optional Isolation Valve	G	2	4
		Without Optional Isolation Valve	H	4	4

\*See page 9 for cooler and condenser size codes.

**RELIEF VALVE ARRANGEMENT, TWO-STAGE COMPRESSOR FRAME SIZE 7 (REFER TO PAGE 73)**

COOLER HEAT EXCHANGER FRAME SIZE*	CONDENSER HEAT EXCHANGER FRAME SIZE*	WITH/WITHOUT DISCHARGE ISOLATION VALVE	VIEW CODE	COOLER NO. VALVES	CONDENSER NO. VALVES
<b>B6</b>	<b>C6</b>	With Optional Isolation Valve	I	2	6
		Without Optional Isolation Valve	J	4	6
<b>B8</b>	<b>C8</b>	With Optional Isolation Valve	I	2	6
		Without Optional Isolation Valve	J	4	6
<b>C6</b>	<b>C6</b>	With Optional Isolation Valve	I	2	6
		Without Optional Isolation Valve	J	4	6
	<b>D6</b>	With Optional Isolation Valve	I	2	6
		Without Optional Isolation Valve	J	4	6
<b>C8</b>	<b>D8</b>	With Optional Isolation Valve	I	3	6
		Without Optional Isolation Valve	J	6	6

\*See page 9 for cooler and condenser size codes.

## RELIEF VALVE ARRANGEMENTS WITH OPTIONAL ISOLATION OF DISCHARGE AND COOLER

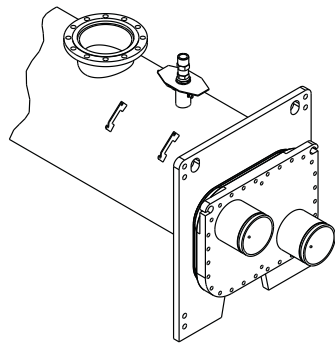

**A**  
**FRAME 1-6**

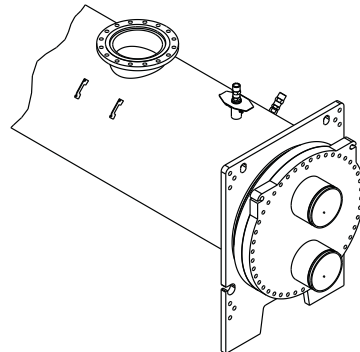

**B**  
**FRAME 7, 8**

## WITHOUT OPTIONAL ISOLATION OF DISCHARGE AND COOLER

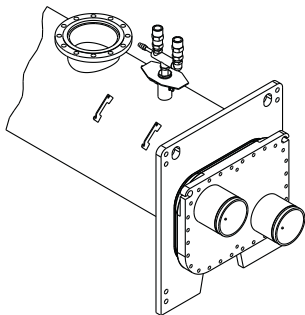

**C**  
**FRAME 1-6**

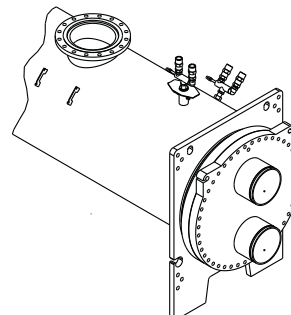

**D**  
**FRAME 7, 8**

## CONDENSER RELIEF VALVE ARRANGEMENT — WITH OR WITHOUT OPTIONAL ISOLATION

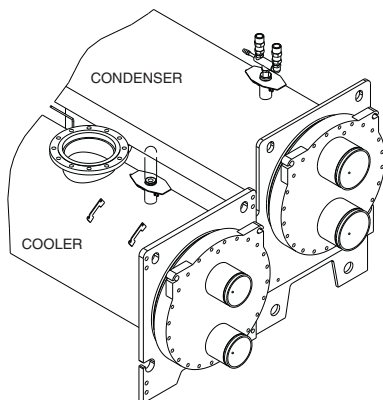

**E**

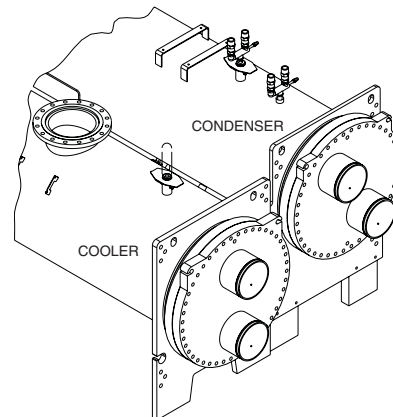

**F**

**FRAME 1-6FRAME 7, 8**

**RELIEF VALVE ARRANGEMENTS (CONT)**

**RELIEF VALVE ARRANGEMENT, TWO-STAGE COMPRESSOR FRAME SIZE 6  
WITH OR WITHOUT OPTIONAL ISOLATION**

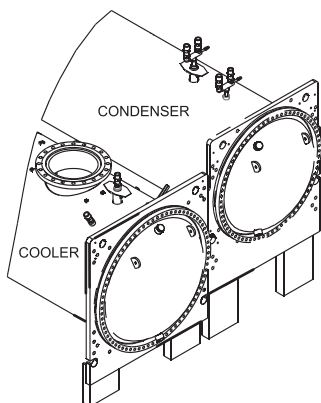

**G — WITH ISOLATION VALVE**

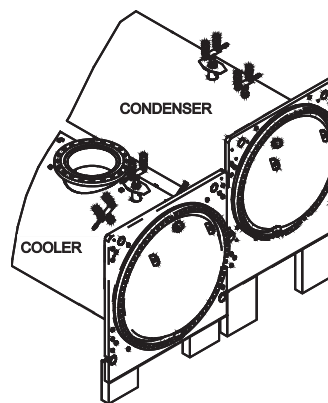

**H — WITHOUT ISOLATION VALVE**

**RELIEF VALVE ARRANGEMENT, TWO-STAGE COMPRESSOR FRAME SIZE 7  
WITH OR WITHOUT OPTIONAL ISOLATION**

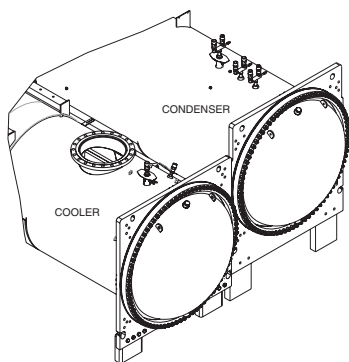

**I — WITH ISOLATION VALVE**

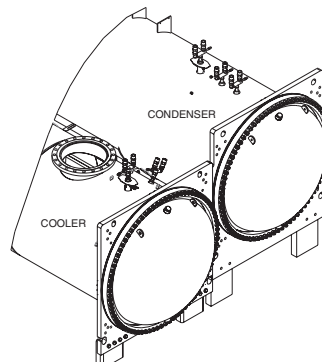

**J — WITHOUT ISOLATION VALVE**

# Application data (cont)



## Vent and drain connections

Nozzle-in-head waterboxes have vent and drain connections on covers. Marine waterboxes have vent and drain connections on waterbox shells.

Provide high points of the chiller piping system with vents and the low points with drains. If shutoff valves are provided in the main water pipes near the unit, a minimal amount of system water is lost when the heat exchangers are drained. This reduces the time required for drainage and saves on the cost of re-treating the system water.

It is recommended that pressure gages be provided at points of entering and leaving water to measure pressure drop through the heat exchanger. Gages may be installed as shown in Pressure Gage Location table. Pressure gages installed at the vent and drain connections do not include nozzle pressure losses.

Use a reliable differential pressure gage to measure pressure differential when determining water flow. Regular gages of the required pressure range do not have the accuracy to provide accurate measurement of flow conditions.

### PRESSURE GAGE LOCATION

NUMBER OF PASSES	GAGE LOCATION (COOLER OR CONDENSER)
1 OR 3	One gage in each waterbox
2	Two gages in waterbox with nozzles

## ASME stamping

All 19XR,XRV heat exchangers are constructed in accordance with ASHRAE (American Society of Heating, Refrigerating, and Air-Conditioning Engineers) 15 Safety Code for Mechanical Refrigeration (latest edition). This code, in turn, requires conformance with ASME (American Society of Mechanical Engineers) Code for Unfired Pressure Vessels wherever applicable.

Each vessel is constructed and certified in accordance with ASME Section 8, Division 1.

## Relief valve discharge pipe sizing

See pages 70 and 71 for number of relief valves and locations.

Relief-valve discharge piping size should be calculated per ASHRAE 15, latest edition, using the tabulated C factors for each vessel shown in the tables on pages 75 and 76.

Carrier further recommends that an oxygen sensor be installed to protect personnel. Sensor should be able to sense the depletion or displacement of oxygen in the machine room below 19.5% volume oxygen per ASHRAE 15, latest edition.

**19XR,XRV RELIEF VALVE DISCHARGE PIPE SIZING, SINGLE-STAGE COMPRESSORS AND TWO-STAGE COMPRESSORS FRAME SIZE E**

HEAT EXCHANGER	FRAME SIZE	VESSEL REQUIRED C FACTOR (LB AIR/MIN)	RELIEF VALVE RATED C FACTOR (LB AIR/MIN)	FIELD CONNECTION SIZE (FPT)
<b>COOLER</b>	10 to 12	30.0	48.4	1"
	15 to 17	36.0	48.4	1"
	20 to 22	35.7	48.4	1"
	30 to 32	43.8	72.1	1 1/4"
	35 to 37	49.9	72.1	1 1/4"
	40 to 42	50.4	72.1	1 1/4"
	45 to 47	57.4	72.1	1 1/4"
	50 to 54, 5A-5C, 5K-5R	53.7	72.1	1 1/4"
	55 to 59, 5F-5H, 5T-5Z	61.1	72.1	1 1/4"
	60 to 64, 6K to 6R	57.0	72.1	1 1/4"
	65 to 69, 6T to 6Z	64.9	72.1	1 1/4"
	70 to 74, 7K to 7R	77.0	144.2	1 1/4"
	75 to 79, 7T to 7Z	88.0	144.2	1 1/4"
	80 to 84, 8K to 8R	87.7	144.2	1 1/4"
	85 to 89, 8T to 8Z	100.3	144.2	1 1/4"
<b>CONDENSER</b>	10 to 12	31.7	48.4	1"
	15 to 17	38.0	48.4	1"
	20 to 22	34.0	48.4	1"
	30 to 32	41.8	72.1	1 1/4"
	35 to 37	47.6	72.1	1 1/4"
	40 to 42	47.1	72.1	1 1/4"
	45 to 47	53.7	72.1	1 1/4"
	50 to 54	51.2	72.1	1 1/4"
	55 to 59	58.3	72.1	1 1/4"
	60 to 64	55.3	72.1	1 1/4"
	65 to 69	63.0	72.1	1 1/4"
	70 to 74 Compressor Frame 5	72.3	144.2	1 1/4"
	75 to 79 Compressor Frame 5	82.7	144.2	1 1/4"
	80 to 84 Compressor Frame 5	80.7	144.2	1 1/4"
	85 to 89 Compressor Frame 5	92.3	144.2	1 1/4"
	70 to 74 Compressor Frame E	88.3	144.2	1 1/4"
	75 to 79 Compressor Frame E	98.7	144.2	1 1/4"
80 to 84 Compressor Frame E	96.7	144.2	1 1/4"	
85 to 89 Compressor Frame E	108.3	144.2	1 1/4"	

# Application data (cont)



## 19XR RELIEF VALVE DISCHARGE PIPE SIZING, TWO-STAGE COMPRESSORS FRAME SIZE 6 AND 7

HEAT EXCHANGER	FRAME SIZE	VESSEL REQUIRED C FACTOR (LB AIR/MIN)	COMBINED RELIEF VALVES RATED C FACTOR (LB AIR/MIN)	FIELD CONNECTION SIZE (FPT)
COOLER	A40 to A47	95.2	144.2	1 1/4"
	A60 to A67	108.8	144.2	1 1/4"
	A4A to A4H	95.2	144.2	1 1/4"
	A6A to A6H	108.8	144.2	1 1/4"
	B60 to B67	123.7	144.2	1 1/4"
	B6A to B6H	123.7	144.2	1 1/4"
	B80 to B87	139.2	144.2	1 1/4"
	B8A to B8H	139.2	144.2	1 1/4"
	C60 to C67	138.7	144.2	1 1/4"
	C6A to C6H	138.7	144.2	1 1/4"
	C80 to C87	156.0	216.3	1 1/4"
	C8A to C8H	156.0	216.3	1 1/4"
CONDENSER AND ECONOMIZER	A40 to A47	110.1*	144.2	1 1/4"
	A60 to A67	122.7*	144.2	1 1/4"
	A4A to A4H	110.1*	144.2	1 1/4"
	A6A to A6H	122.7*	144.2	1 1/4"
	B40 to B47	120.9*	144.2	1 1/4"
	B60 to B67	134.9*	144.2	1 1/4"
	B4A to B4H	120.9*	144.2	1 1/4"
	B6A to B6H	134.9*	144.2	1 1/4"
	C60 to C67	164.7*	216.3	1 1/4"
	C6A to C6H	164.7*	216.3	1 1/4"
	C80 to C87	186.2*	216.3	1 1/4"
	C8A to C8H	186.2*	216.2	1 1/4"
	D60 to D67	164.7*	216.3	1 1/4"
	D6A to D6H	164.7*	216.3	1 1/4"
	D80 to D87	206.0	216.3	1 1/4"
	D8A to D8H	206.0	216.3	1 1/4"

\*The condenser discharge required C factor is the combined values of the condenser, high-side float, and economizer.

### Design pressures

Design and test pressures for heat exchangers are listed below.

#### DESIGN AND MINIMUM TEST PRESSURES

VESSEL	PRESSURES	SHELL SIDE (REFRIGERANT)		STANDARD TUBE SIDE (WATER)		OPTIONAL TUBE SIDE (WATER)	
		PSIG	KPA	PSIG	KPA	PSIG	KPA
Cooler	Design	185	1276	150	1034	300	2068
	Leak Test (min)	185	1276	150	1034	300	2068
	Hydrostatic Test	—	—	195	1344	390	2690
	Proof Test (min Pneumatic)	204	1407	—	—	—	—
Condenser	Design	185	1276	150	1034	300	2068
	Leak Test (min)	185	1276	150	1034	300	2068
	Hydrostatic Test	—	—	195	1344	390	2690
	Proof Test (min Pneumatic)	204	1407	—	—	—	—
Economizer Frame Size E	Design	185	1276	—	—	—	—
	Leak Test (min)	185	1276	—	—	—	—
	Hydrostatic Test	—	—	—	—	—	—
	Proof Test (min Pneumatic)	204	1407	—	—	—	—
Economizer, Frame Sizes 6 and 7	Design	185	1276	—	—	—	—
	Leak Test (min)	185	1276	—	—	—	—
	Hydrostatic Test	—	—	—	—	—	—
	Proof Test (min Pneumatic)	204	1407	—	—	—	—

## HEAT EXCHANGER MATERIAL SPECIFICATIONS

ITEM	MATERIAL	SPECIFICATION
Shell	HR Steel	ASME SA516 GR .70
Tube Sheet	HR Steel	ASME SA516 GR .70
Flat Covers	HR Steel	ASME/ASTM A516 GR.70
Pipe	Steel	ASME SA106 GRB/SA53 E/B
Flanges	Steel	ASME B16.5
Condenser Float Box Shell	Steel	ASME SA53 E/B
Tubes	Per Job Requirement	ASME SB359
Dished Cover	HR Steel	ASTM A516 GR.70/GB713 Q345R
Marine Water Box Shell	HR Steel	ASME/ASTM A516 GR.70

## ECONOMIZER MATERIAL SPECIFICATIONS

ITEM	MATERIAL	SPECIFICATION
Shell	Steel	ASME SA53 E/B
Cover	HR Steel	ASME SA516 GR.70
Pipe	Steel	ASME SA106 GR.70

### LEGEND

**ASME** — American Society of Mechanical Engineers  
**ASTM** — American Society for Testing and Materials  
**HR** — Hot Rolled

## Insulation

### Factory insulation (optional)\*

The factory insulation option for the 19XR, XRV chillers include the following areas: cooler (not including water-box); suction line up to the compressor suction housing; compressor motor and motor cooling return lines; several small oil cooling and oil return system lines; the liquid line; the float chamber; and VFD refrigerant drain lines (19XRV units only). For two-stage chillers, factory insulation also includes economizer and economizer piping. Insulation applied at the factory is  $\frac{3}{4}$ -in. (19-mm) thick and has a thermal conductivity K value of 0.28 (Btu in./hr ft<sup>2</sup> °F [(0.0404 • W)/(m • °C)]). Insulation conforms with Underwriters Laboratories (UL) Standard 94, Classification 94HBF.

\* On compressor frame sizes 6 and 7 the condenser is insulated as standard.

## MINIMUM FIELD-INSTALLED INSULATION REQUIREMENTS\*

CHILLER	HEAT EXCHANGER SIZE	INSULATION*	
		FT <sup>2</sup>	M <sup>2</sup>
<b>19XR, XRV SINGLE-STAGE AND TWO-STAGE FRAME SIZE E</b>	10-12	75	6.9
	15-17	85	7.9
	20-22	100	9.3
	30-32	125	11.7
	35-37	135	12.6
	40-42	155	14.4
	45-47	170	15.8
	50-54, 5A-5C, 5K-5R	170	15.8
	55-59, 5F-5H, 5T-5Z	185	17.2
	60-64, 6K-6R	185	17.2
	65-69, 6T-6Z	205	19.1
	70-74, 7K-7R	260	24.2
	75-79, 7T-7Z	295	27.4
	80-84, 8K-8R	310	28.8
85-89, 8T-8Z	355	32.9	

CHILLER	COOLER FRAME SIZE	INSULATION†	
		FT <sup>2</sup>	M <sup>2</sup>
<b>19XR TWO-STAGE FRAME SIZE 6</b>	A40-A47 and A4A-A4H	434	40.3
	A60-A67 and A6A-A6H	462	42.9
<b>19XR TWO-STAGE FRAME SIZE 7</b>	B60-B67 and B6A-B6H	666	61.9
	B80-B87 and B8A to B8H	699	64.9
	C60-C67 and C6A-C6H	694	64.9
	C80-C87 and C8A-C8H	732	68.0

\* Add 50 sq ft additional insulation for economizer on two-stage chiller.

† Factory installed as shown on page 80.

NOTE: Insulation amount includes only the amount of insulation required to insulate the sections of the chiller that would be included in the factory-installed insulation option.



## Insulation at jobsite

As indicated in the Condensation vs. Relative Humidity table, the factory insulation provides excellent protection against condensation under most operating conditions. If temperatures in the equipment area exceed the maximum design conditions, extra insulation is recommended.

If the machine is to be field insulated, obtain the approximate areas from the Minimum Field-Installed Insulation Requirements table.

Insulation of waterbox is made only in the field and this area is not included in Minimum Field-Installed Insulation Requirements table. When insulating the covers, allow for service access and removal of covers. To estimate water-box cover areas refer to certified drawings.

High humidity jobsite locations may require field supplied and installed insulation on the float chamber, suction housing, and the lower half of the condenser.

## CONDENSATION VS. RELATIVE HUMIDITY\*

AMOUNT OF CONDENSATION	ROOM DRY-BULB TEMP		
	80°F (27°C)	90°F (32°C)	100°F (38°C)
	% RELATIVE HUMIDITY		
NONE	80	76	70
SLIGHT	87	84	77
EXTENSIVE	94	91	84

\* These approximate figures are based on 35°F (1.7°C) saturated suction temperature. A 2°F (1.1°C) change in saturated suction temperature changes the relative humidity values by 1% in the same direction.

## Unit location

Chiller should be installed in an indoor environment where the ambient temperature is 40 to 104°F (4 to 40°C) with a relative humidity (non-condensing) of 95% or less. To ensure that electrical components operate properly, do not locate the chiller in an area exposed to dust, dirt, corrosive fumes, or excessive heat and humidity.

### 19XR, XRV FACTORY-INSTALLED INSULATION AREA SINGLE-STAGE CHILLER

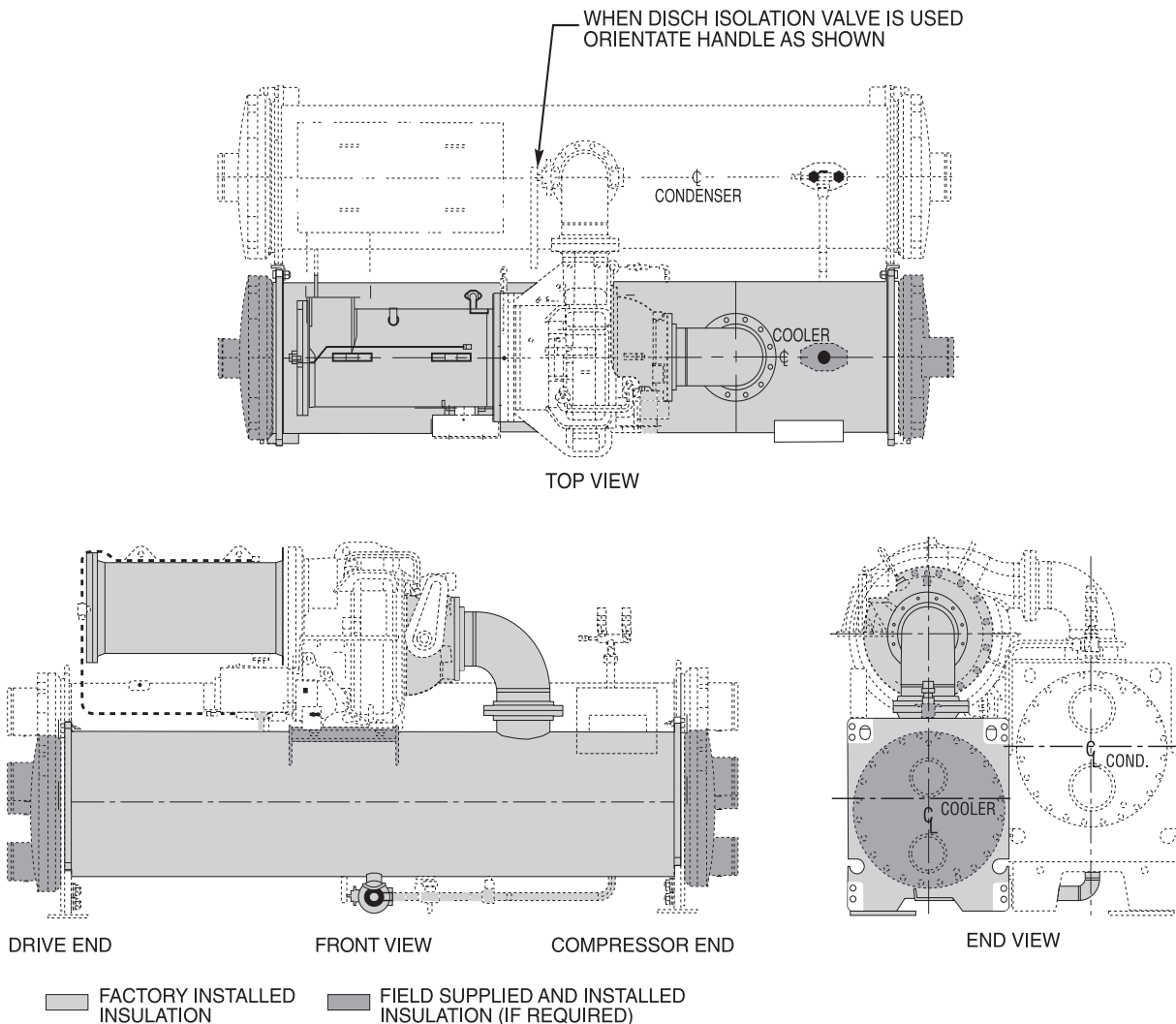

**19XR,XRV FACTORY-INSTALLED INSULATION AREA (CONT)  
TWO-STAGE CHILLER FRAME E**

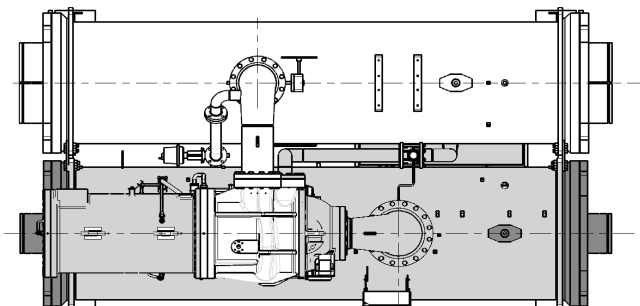

TOP VIEW

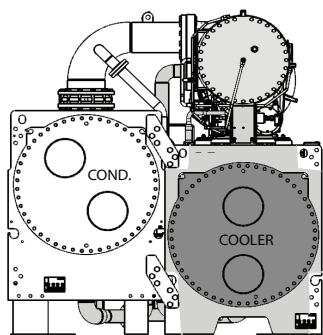

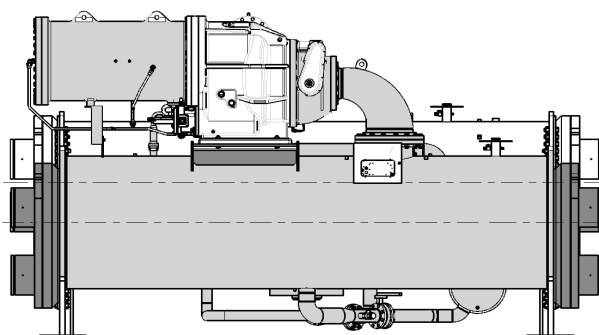

DRIVE END VIEW

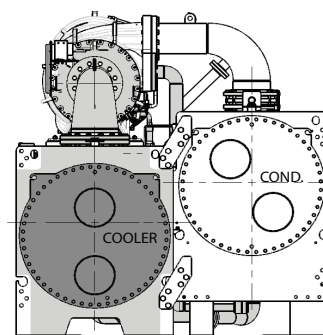

FRONT VIEW



COMPRESSOR END VIEW

-  FACTORY INSTALLED INSULATION
-  FIELD SUPPLIED AND INSTALLED INSULATION (IF REQUIRED)

## 19XR FACTORY-INSTALLED INSULATION AREA TWO-STAGE CHILLER FRAME SIZES 6 AND 7

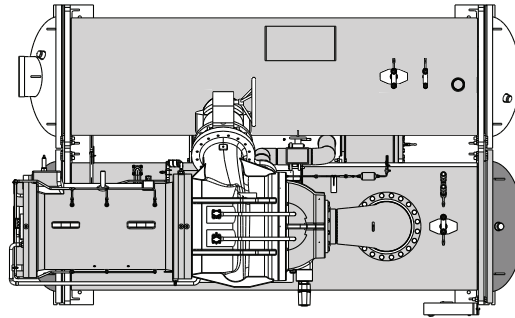

TOP VIEW

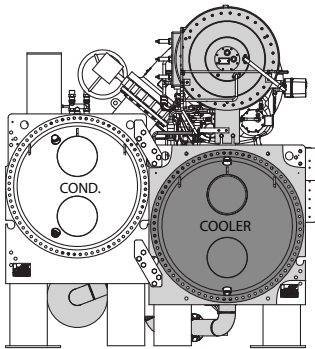

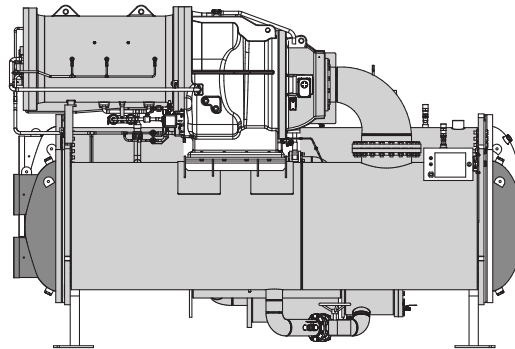

DRIVE END VIEW

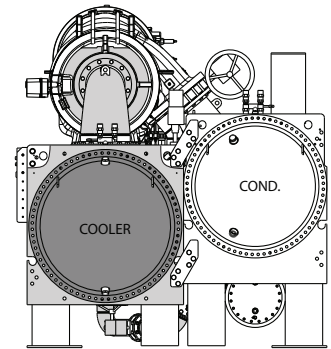

FRONT VIEW



COMPRESSOR END VIEW

-  FACTORY INSTALLED INSULATION
-  FIELD SUPPLIED AND INSTALLED INSULATION (IF REQUIRED)

NOTE: Compressor frame size 6 is shown.

## Packaged Semi-Hermetic Centrifugal Liquid Chiller

### HVAC Guide Specifications — 19XR, XRV

#### Size Range:

**19XR,XRV — 200 to 3400 Tons  
(703 to 11957 kW) Nominal**

#### Carrier Model Number:

**19XR,XRV**

#### Part 1 — General

##### 1.01 SYSTEM DESCRIPTION

- A. Microprocessor-controlled liquid chiller shall use a semi-hermetic centrifugal compressor using refrigerant HFC-134a.
- B. If a manufacturer proposes a liquid chiller using HCFC-123 refrigerant, then the manufacturer shall include in the chiller price:
  1. A vapor activated alarm system shall be capable of responding to HCFC-123 levels of 10 ppm Allowable Exposure Limit (AEL).
  2. External refrigerant storage tank and pumpout unit.
  3. Zero emission purge unit capable of operating even when the chiller is not operating.
  4. Back-up relief valve to rupture disk.
  5. Chiller pressurizing system to prevent leakage of noncondensables into chiller during shut-down periods.
  6. Plant room ventilation.

##### 1.02 QUALITY ASSURANCE

- A. Chiller performance shall be rated in accordance with AHRI (Air-Conditioning, Heating and Refrigeration Institute) Standard 550/590, latest edition.
- B. Equipment and installation shall be in compliance with ANSI/ASHRAE (American National Standards Institute/American Society of Heating, Refrigerating and Air-Conditioning Engineers) 15 (latest edition).
- C. Cooler and condenser refrigerant side shall include ASME “U” stamp and nameplate certifying compliance with ASME Section VIII, Division 1 code for unfired pressure vessels.
- D. Chiller shall be designed and constructed to meet UL (Underwriters Laboratories) and UL, Canada requirements and have labels appropriately affixed.
- E. Centrifugal compressor impellers shall be dynamically balanced and over-speed tested by the manufacturer at a minimum of 120% design operating speed. Each compressor assembly shall undergo a mechanical run-in test to verify vibration levels, oil pressures, and temperatures are within acceptable limits.
- F. Each compressor assembly shall be proof tested at a minimum 204 psig (1406 kPa) and leak tested at 185 psig (1276 kPa) with a tracer gas mixture.
- G. Entire chiller assembly shall be proof tested at 204 psig (1406 kPa) and leak tested at 185 psig (1276

kPa) with a tracer gas mixture on the refrigerant side. The water side of each heat exchanger shall be hydrostatically tested at 1.3 times rated working pressure.

- H. Prior to shipment, the chiller automated controls test shall be executed to check for proper wiring and ensure correct controls operation.
  - I. On chillers with unit-mounted compressor motor starter or VFD (variable frequency drive), the chiller and starter/VFD shall be factory wired and tested together to verify proper operation prior to shipment.
  - J. The management system governing the manufacture of this chiller shall be ISO 9001:2008 certified.

##### 1.03 DELIVERY, STORAGE AND HANDLING

- A. Unit shall be stored and handled in accordance with manufacturer's instructions.
- B. Unit shall be shipped with all refrigerant piping and control wiring factory installed.
- C. Unit shall be shipped charged with oil and full charge of refrigerant HFC-134a or a nitrogen holding charge as specified on the equipment schedule.
- D. Unit shall be shipped with firmly attached labels that indicate name of manufacturer, chiller model number, chiller serial number, and refrigerant used.
- E. If the chiller is to be exported, the unit shall be sufficiently protected from the factory against sea water corrosion to be suitable for shipment in a standard open top, ocean shipping container (19XR,XRV heat exchanger frames 1 through 6 only).

##### 1.04 WARRANTY

Warranty shall include parts and labor for one year after start-up or 18 months from shipment, whichever occurs first.

#### Part 2 — Products

##### 2.01 EQUIPMENT

- A. General:

Factory assembled, single piece, liquid chiller shall consist of compressor, motor, starter or variable frequency drive, lubrication system, cooler, condenser, initial oil and refrigerant operating charges, microprocessor control system, and documentation required prior to start-up. An optional compressor motor starter or VFD can be mounted on the chiller, wired, and tested by the chiller manufacturer (select models). Or, an optional free-standing medium voltage starter or VFD can be wired and tested by the chiller manufacturer.
- B. Compressor:
  1. One high performance centrifugal compressor.
  2. Compressor, motor, and transmission shall be semi-hermetically sealed into a common assembly and arranged for easy field servicing.
  3. Internal compressor parts must be accessible for servicing without removing the compressor base from the chiller. Connections to the compressor

casing shall use O-rings instead of gaskets to reduce the occurrence of refrigerant leakage. Connections to the compressor shall be flanged or bolted for easy disassembly.

4. All pressure transducers shall have quick disconnects to allow replacement of the sensor without replacement of the entire sensor wire. Pressure transducers shall be capable of field calibration to ensure accurate readings and to avoid unnecessary transducer replacement. Pressure transducers and temperature sensors shall be serviceable without the need for refrigerant charge removal or isolation.
5. Transmission shall be helical, parallel shaft speed increaser. Gears shall conform to AGMA 2001-B88, Class 11.
6. Journal bearings shall be of the steel backed babbit lined type. Aluminum journal bearings are not acceptable. The thrust bearing shall be tilting pad or rolling element type.
7. Centrifugal compressors shall use variable inlet guide vanes to provide capacity modulation while also providing pre-whirl of the refrigerant vapor entering the impeller for more efficient compression at all loads.
8. Centrifugal compressors shall be provided with a factory-installed lubrication system to deliver oil under pressure to bearings and transmission. Included in the system shall be:
  - a. Hermetic driven oil pump with factory-installed motor contactor with overload protection.
  - b. Refrigerant-cooled oil cooler. Water-cooled oil coolers are not acceptable.
  - c. Oil pressure regulator.
  - d. Oil filter with isolation valves to allow filter change without removal of refrigerant charge.
  - e. Oil sump heater controlled from unit micro-processor.
  - f. Oil reservoir temperature sensor with main control center digital readout.
  - g. When factory-mounted compressor motor starter or VFD is provided, all wiring to oil pump, oil heater, and controls shall be pre-wired in the factory.
  - h. Compressor shall be fully field serviceable. Compressors which must be removed and returned to the factory for service shall be unacceptable.

## C. Motor:

1. Compressor motor shall be of the semi-hermetic, liquid refrigerant cooled, squirrel cage, induction type suitable for voltage shown on the equipment schedule.

2. If an open drive motor is provided, a compressor shaft seal leakage containment system shall be provided.
  - a. An oil reservoir shall collect oil and refrigerant that leaks past the seal.
  - b. A float device shall be provided to open when the reservoir is full, directing the refrigerant/oil mixture back into the compressor housing.
  - c. A refrigerant sensor shall be located next to the open drive seal to detect leaks.
3. Motors shall be suitable for operation in a refrigerant atmosphere and shall be cooled by atomized refrigerant in contact with the motor windings.
4. Motor stator shall be arranged for service or removal with only minor compressor disassembly and without removing main refrigerant piping connections.
5. Full load operation of the motor shall not exceed nameplate rating.
6. At least one motor winding temperature sensor (and one spare) shall be provided.
7. Should the mechanical contractor choose to provide a chiller with an open motor instead of the specified semi-hermetic motor, the contractor shall install additional cooling equipment to dissipate the motor heat as per the following formula:

$$\text{Btuh} = (\text{FLkW motor}) (0.05) (3413)$$

$$\text{Btuh} = (\text{FLkW motor}) (171)$$

and, alternately

$$\text{Tons} = \text{Btuh} / 12,000$$

The additional piping, valves, air-handling equipment, insulation, wiring, switchgear changes, ductwork, and coordination with other trades shall be the responsibility of the mechanical contractor. Shop drawings reflecting any changes to the design shall be included in the submittal, and incorporated into the final as-built drawings for the project.

8. Also, if an open motor is provided, a mechanical room thermostat shall be provided and set at 104°F (40°C). If this temperature is exceeded, the chillers shall shut down and an alarm signal shall be generated to the central Energy Management System (EMS) display module prompting the service personnel to diagnose and repair the cause of the over-temperature condition. The mechanical contractor shall be responsible for all changes to the design, including coordination with temperature control, electrical and other trades. In addition, the electrical power consumption of any auxiliary ventilation and/or mechanical cooling required to maintain the mechanical room conditions stated above shall be considered in the determination of conformance to the scheduled chiller energy efficiency requirement.



#### D. Cooler and Condenser:

1. Cooler shall be of shell and tube type construction, each in separate shells. Units shall be fabricated with high-performance tubing, minimum 1/4-in. (6-mm) steel shell and tube sheets with fabricated steel waterboxes.
  - a. Waterbox shall be nozzle-in-head waterbox (150 psig [1034 kPa]).
  - b. Waterbox shall have standard Victaulic grooves. For 19XR with Frame 6 or Frame 7 compressor, the Victaulic AGS grooves shall be provided for nominal 14-in. pipe and larger.
2. Condenser shall be of shell and tube type construction, each in separate shells. Units shall be fabricated with high-performance tubing, minimum 1/4-in. (6-mm) steel shell and tube sheets with fabricated steel waterboxes.
  - a. Waterbox shall be nozzle-in-head (150 psig [1034 kPa]).
  - b. Waterbox shall have standard Victaulic grooves. For 19XR with Frame 6 or Frame 7 compressor, the Victaulic AGS grooves shall be provided for nominal 14-in. pipe and larger.
3. Waterboxes shall have vents, drains, and covers to permit tube cleaning within the space shown on the drawings. A thermistor type temperature sensor with quick connects shall be factory installed in each water nozzle.
4. Tubes shall be individually replaceable from either end of the heat exchanger without affecting the strength and durability of the tube sheet and without causing leakage in adjacent tubes.
5. Tubing shall be copper, high-efficiency type, with integral internal and external enhancement unless otherwise noted. Tubes shall be nominal 3/4-in. or 1-in. OD with nominal wall thickness of 0.025 in. measured at the root of the fin at the enhanced areas and nominal wall thickness of 0.049 in. where the tubes are in contact with the end tube sheets unless otherwise noted. Tubes shall be rolled into tube sheets and shall be individually replaceable. Tube sheet holes shall be double grooved for joint structural integrity.
6. Cooler shall be designed to prevent liquid refrigerant from entering the compressor.
7. The condenser shell shall include a FLASC (flash subcooler) which cools the condensed liquid refrigerant to a reduced temperature, thereby increasing the refrigeration cycle efficiency.
8. A reseating type pressure relief valve shall be installed on each heat exchanger. If a non-reseating type is used, a backup reseating type shall be installed in series.

#### E. Refrigerant Flow Control:

1. To maintain optimal part load efficiency, the refrigerant expansion device to the cooler and as applicable to the economizer, shall use a variable metering valve, such as a float or actuated valve. To ensure good operating performance, the valve design will prevent refrigerant gas from the condenser from passing to the cooler or economizer at full or part load.
2. By maintaining a liquid seal at the flow valve, bypassed hot gas from the condenser to the cooler is eliminated. The float valve chamber shall have a bolted access cover to allow field inspection and the float valve shall be field serviceable.

#### F. Controls, Safeties, and Diagnostics:

1. Controls:
  - a. The chiller shall be provided with a factory installed and wired microprocessor control center. The microprocessor can be configured for either English or SI units.
  - b. All chiller and starter monitoring shall be displayed at the chiller control panel.
  - c. The controls shall make use of non-volatile memory.
  - d. The chiller control system shall have the ability to interface and communicate directly to the building control system.
  - e. The default standard display screen shall simultaneously indicate the following minimum information:
    - 1) date and time of day
    - 2) 24-character primary system status message
    - 3) 24-character secondary status message
    - 4) chiller operating hours
    - 5) entering chilled water temperature
    - 6) leaving chilled water temperature
    - 7) evaporator refrigerant temperature
    - 8) entering condenser water temperature
    - 9) leaving condenser water temperature
    - 10) condenser refrigerant temperature
    - 11) oil supply pressure
    - 12) oil sump temperature
    - 13) percent motor rated load amps (RLA)
  - f. In addition to the default screen, status screens shall be accessible to view the status of every point monitored by the control center including:
    - 1) evaporator pressure
    - 2) condenser pressure
    - 3) bearing oil supply temperature
    - 4) compressor discharge temperature
    - 5) motor winding temperature
    - 6) number of compressor starts
    - 7) control point settings
    - 8) discrete output status of various devices
    - 9) compressor motor starter status
    - 10) optional spare input channels

- 11) current and voltage for each phase
- 12) frequency

g. Schedule Function:

The chiller controls shall be configurable for manual or automatic start-up and shutdown. In automatic operation mode, the controls shall be capable of automatically starting and stopping the chiller according to a stored user programmable occupancy schedule. The controls shall include built-in provisions for accepting:

- 1) A minimum of two 365-day occupancy schedules.
- 2) Minimum of 8 separate occupied/unoccupied periods per day.
- 3) Daylight savings start/end.
- 4) Minimum of 18 user-defined holidays.
- 5) Means of configuring an occupancy timed override.
- 6) Chiller start-up and shutdown via remote contact closure.

h. Service Function:

The controls shall provide a password protected service function which allows authorized individuals to view an alarm history file which shall contain the last 25 alarm/alert messages with time and date stamp. These messages shall be displayed in text form, not codes.

i. Network Window Function:

Each chiller control panel shall be capable of viewing multiple point values and statuses from other like controllers connected on a common network, including controller maintenance data. The operator shall be able to alter the remote controller's set points or time schedule and to force point values or statuses for those points that are operator forcible. The control panel shall also have access to the alarm history file of all like controllers connected on the network.

j. Pump Control:

Upon request to start the compressor, the control system shall start the chilled water pump, condenser water pumps and verify that flows have been established.

k. Ramp Loading:

A user-configurable ramp loading rate, effective during the chilled water temperature pull-down period, shall control the rate of guide vane opening to prevent a rapid increase in compressor power consumption. The controls shall allow configuration of the ramp loading rate in either degrees/minute of chilled water temperature pull-down or percent motor amps/minute. During the ramp loading period, a message shall be displayed

informing the operator that the chiller is operating in ramp loading mode.

l. Chilled Water Reset:

The control center shall allow reset of the chilled water temperature set point based on any one of the following criteria:

- 1) Chilled water reset based on an external 4 to 20 mA signal.
- 2) Chilled water reset based on a remote temperature sensor (such as outdoor air).
- 3) Chilled water reset based on water temperature rise across the evaporator.

m. Demand Limit:

The control center shall limit amp draw of the compressor to the rated load amps or to a lower value based on one of the following criteria:

- 1) Demand limit based on a user input ranging from 40% to 100% of compressor rated load amps.
- 2) Demand limit based on external 4 to 20 mA signal.

n. Controlled Compressor Shutdown:

The controls shall be capable of being configured to soft stop the compressor. When the stop button is pressed or remote contacts open with this feature active, the guide vanes shall close to a configured amperage level and the machine shall then shut down. The display shall indicate "shutdown in progress."

2. Safeties:

a. Unit shall automatically shut down when any of the following conditions occur: (Each of these protective limits shall require manual reset and cause an alarm message to be displayed on the control panel screen, informing the operator of the shutdown cause.)

- 1) motor overcurrent
- 2) over voltage\*
- 3) under voltage\*
- 4) single cycle dropout\*
- 5) bearing oil high temperature
- 6) low evaporator refrigerant temperature
- 7) high condenser pressure
- 8) high motor temperature
- 9) high compressor discharge temperature
- 10) low oil pressure
- 11) prolonged surge
- 12) loss of cooler water flow
- 13) loss of condenser water flow
- 14) starter fault

\*Shall not require manual reset or cause an alarm if auto-restart after power failure is enabled.

b. The control system shall detect conditions that approach protective limits and take self-corrective action prior to an alarm occurring.



The system shall automatically reduce chiller capacity when any of the following parameters are outside their normal operating range:

- 1) high condenser pressure
- 2) high motor temperature
- 3) low evaporator refrigerant temperature
- 4) surge prevention control
- 5) high motor amps.

- c. During the capacity override period, a pre-alarm (alert) message shall be displayed informing the operator which condition is causing the capacity override. Once the condition is again within acceptable limits, the override condition shall be terminated and the chiller shall revert to normal chilled water control. If during either condition the protective limit is reached, the chiller shall shut down and a message shall be displayed informing the operator which condition caused the shutdown and alarm.
- d. Internal built-in safeties shall protect the chiller from loss of water flow. Differential pressure switches shall not be allowed to be the only form of freeze protection.

### 3. Diagnostics and Service:

- a. A self diagnostic controls test shall be an integral part of the control system to allow quick identification of malfunctioning components.
- b. Once the controls test has been initiated, all pressure and temperature sensors shall be checked to ensure they are within normal operating range. A pump test shall automatically energize the chilled water pump, condenser water pump, and oil pump. The control system shall confirm that water flow and oil pressure have been established and require operator confirmation before proceeding to the next test. A guide vane actuator test shall open and close the guide vanes to check for proper operation. The operator manually acknowledges proper guide vane operation prior to proceeding to the next test.
- c. In addition to the automated controls test, the controls shall provide a manual test which permits selection and testing of individual control components and inputs. A thermistor test and transducer test shall display and an actual reading shall be performed for each transducer and each thermistor installed on the chiller. All out-of-range sensors shall be identified.

### 4. Multiple Chiller Control:

The chiller controls shall be supplied as standard with a two-chiller lead/lag and a third chiller standby system. The control system shall automatically start and stop a lag or second chiller on a two-chiller system. If one of the two

chillers on line goes into a fault mode, the third standby chiller shall be automatically started. The two-chiller lead/lag system shall allow manual rotation of the lead chiller, include load balancing if configured, and a staggered restart of the chillers after a power failure.

### G. Electrical Requirements:

1. Electrical contractor shall supply and install main electrical power line, disconnect switches, circuit breakers, and electrical protection devices per local code requirements and as indicated necessary by the chiller manufacturer.
2. Electrical contractor shall wire the chilled water pump, condenser water pump, and tower fan control circuit to the chiller control circuit.
3. Electrical contractor shall supply and install electrical wiring and devices required to interface the chiller controls with the building control system if applicable.
4. Electrical power shall be supplied to the unit at the voltage, phase, and frequency listed in the equipment schedule.

### H. Piping Requirements — Instrumentation and Safeties:

1. Mechanical contractor shall supply and install pressure gages in readily accessible locations in piping adjacent to the chiller such that they can be easily read from a standing position on the floor. Scale range shall be such that design values shall be indicated at approximately mid-scale.
2. Gages shall be installed in the entering and leaving water lines of the cooler and condenser.

### I. Vibration Isolation:

Chiller manufacturer shall furnish neoprene isolator pads for mounting equipment on a level concrete surface.

### J. Start-up:

1. The chiller manufacturer shall provide a factory-trained representative, employed by the chiller manufacturer, to perform the start-up procedures as outlined in the Start-up, Operation and Maintenance manual provided by the chiller manufacturer.
2. Manufacturer shall supply the following literature:
  - a. Start-up, operation and maintenance instructions.
  - b. Installation instructions.
  - c. Field wiring diagrams.
  - d. One complete set of certified drawings.

### K. Special Features:

#### 1. Soleplate Package Accessory:

Unit manufacturer shall furnish a soleplate package consisting of soleplates, jacking screws, leveling pads, and neoprene pads.

2. Spring Isolators Accessory:  
Field furnished and selected for the desired degree of isolation.
3. Spare Sensors with Leads Accessory:  
Unit manufacturer shall furnish additional temperature sensors and leads.
4. Sound Insulation Kit Accessory (not available on compressor frames 6 and 7):  
Unit manufacturer shall furnish a sound insulation kit that covers (select):
  - a. The compressor discharge pipe.
  - b. The compressor housing and motor housing.
  - c. The condenser shell and suction line.Blanket construction shall allow for installation and removal without the use of tape or caulk. Insulation material shall be 11 lb/cu ft fiberglass. Insulation design shall accommodate temperature and pressure probes, gages, tubing, piping, and brackets. An extended 2-in. wide vinyl flap shall cover all exposed seams, thereby minimizing any potential noise leaks. An aluminum nameplate shall be riveted to each blanket piece. Each tag shall be embossed or etched with lettering indicating piece location, description, size, and tag number sequence.
5. Stand-Alone Pumpout Unit Accessory:  
A free-standing pumpout shall be provided. The pumpout unit shall use a hermetic reciprocating compressor with water-cooled condenser. Condenser water piping, 3-phase motor power shall be installed at the jobsite by the installing contractor.
6. Separate Storage Tank and Pumpout Unit Accessory:  
A free-standing refrigerant storage tank and pumpout unit shall be provided. The storage vessels shall be designed per ASME Section VIII Division 1 code with 185 psig (1276 kPa) design pressure. Double relief valves per ANSI/ASHRAE 15, latest edition, shall be provided. The tank shall include a liquid level gage and pressure gage. The pumpout unit shall use a hermetic reciprocating compressor with water cooled condenser. Condenser water piping and 3-phase motor power shall be installed at the jobsite by the installing contractor.
7. Building Control System Interface Accessory:  
The chiller control system shall have the ability to interface and communicate directly to the building control using a LON-based system. The LonWorks<sup>1</sup> Carrier Translator shall output data in standard LON profiles. (19XR compressor frame sizes 2 to 5, E only.)
8. Refrigerant Charge:  
The chiller shall ship from the factory fully charged with R-134a refrigerant and oil.
9. Thermal Insulation:  
Unit manufacturer shall insulate the cooler shell, economizer low side compressor suction elbow, motor shell, and motor cooling lines. Insulation shall be  $\frac{3}{4}$ -in. (19-mm) thick with a thermal conductivity not exceeding 0.28 (Btu in.)/hr ft<sup>2</sup> F [(0.0404 • W)/(m • °C)] and shall conform to UL standard 94, classification 94 HBF.
10. Automatic Hot Gas Bypass:  
Hot gas bypass valve and piping shall be factory furnished to permit chiller operation for extended periods of time.
11. Cooler and Condenser Tubes:  
Contact local Carrier representative for other tube offerings.
12. Cooler and Condenser Passes:  
Unit manufacturer shall provide the cooler and/or condenser with 1, 2 or 3 pass configuration on the water side.
13. Nozzle-In-Head, 300 psig (2068 kPa):  
Unit manufacturer shall furnish nozzle-in-head style waterboxes on the cooler and/or condenser rated at 300 psig (2068 kPa).
14. Marine Waterboxes, 150 psig (1034 kPa):  
Unit manufacturer shall furnish marine style waterboxes on cooler and/or condenser rated at 150 psig (1034 kPa).
15. Marine Waterboxes, 300 psig (2068 kPa):  
Unit manufacturer shall furnish marine style waterboxes on cooler and/or condenser rated at 300 psig (2068 kPa).
16. Flanged Waterbox Nozzles:  
Unit manufacturer shall furnish standard flanged piping connections on the cooler and/or condenser.
17. Hinges:  
Unit manufacturer shall furnish hinges on waterboxes to facilitate tube cleaning.
18. Pumpout Unit:  
A refrigerant pumpout system shall be installed on the chiller. The pumpout system shall include a hermetic compressor and drive, piping, wiring, and motor. (19XR compressor frame sizes 2 to 5, E only.)
19. Optional Compressor Discharge Isolation Valve and Liquid Line Ball Valve:  
These items shall be factory installed to allow isolation of the refrigerant charge in the condenser for servicing the compressor.

1. LonWorks is a registered trademark of Echelon Corporation.

20. Optional Seismic Isolation Package (Select Models Only):

Package shall meet International Building Code and ASCE 7 seismic qualification requirements in concurrence with ICC ES AC156 Acceptance Criteria for Seismic Qualification by Shake-Table Testing of Nonstructural Components and Systems. Manufacturer shall provide seismic certificate from OSHPD (California only).

21. BACnet<sup>1</sup> Communication Option:

Shall provide factory-installed communication capability with a BACnet network. Allows integration with i-Vu<sup>®</sup> Open control system or a BACnet building automation system. (Integration with i-Vu requires the use of the i-Vu Link module for compressor frames 6 and 7. The UPC Open module is required for compressor frames 2-5, E.)

22. Optional Low-Voltage Unit-Mounted Starter (not available on chiller heat exchanger sizes 8, A, B, C, or D):

An optional reduced voltage wye-delta or solid-state starter shall be supplied. The compressor motor starter shall be factory mounted, wired and tested prior to shipment by the chiller manufacturer. Customer electrical connection for compressor motor power shall be limited to main power leads to the starter, and wiring water pumps and tower fans to the chiller control circuit.

- a. NEMA 1 enclosure with integral fan cooling and lockable hinged doors.
- b. Main power disconnect (non-fused type).
- c. Capability to start and stop chiller, pumps and tower fans.
- d. 3 kva control/oil heater transformer.
- e. Branch circuit breaker to provide power for oil pump.
- f. Branch circuit breaker to provide power for control power and oil heater.
- g. The following are standard features:
  - 1) Phase loss
  - 2) Phase reversal
  - 3) Phase imbalance
  - 4) 3-phase ground fault
  - 5) Low voltage — phase to phase and phase to ground
  - 6) Medium voltage — phase to ground
  - 7) Current overload
  - 8) Current flow while stopped
  - 9) 3-phase under/over voltage
  - 10) 3-phase digital ammeter/voltmeter
  - 11) Microprocessor based overload trip protection

12) Frequency digital display

h. Optional unit-mounted solid-state starter shall provide stepless compressor motor acceleration. The starter shall include 6 silicon controlled rectifiers (SCRs) with integrally mounted bypass once the motor has achieved full voltage and speed. The starter shall also display the following:

- 1) Starter On
- 2) Run (up to voltage)
- 3) Phase Correct
- 4) Overtemperature Fault
- 5) SCR Gates Energized
- 6) Ground Fault
- 7) Current Imbalance Fault
- 8) Shorted SCR

23. Unit-Mounted Variable Frequency Drive (VFD) with Built-in Harmonic Filter (LiquiFlo™ 2, available for low voltage only):

a. Design:

- 1) VFD shall be refrigerant cooled, micro-processor based, pulse width modulated (PWM) design. Water-cooled designs are not acceptable.
- 2) Input and output power devices shall be insulated gate bipolar transistors (IGBTs).
- 3) Active rectifier shall convert incoming voltage / frequency to DC voltage. Input current and voltage shall be regulated.
- 4) Transistorized inverter and control regulator shall convert DC voltage to a sinusoidal PWM waveform.
- 5) Integrated chiller controls shall coordinate motor speed and guide vane position to optimize chiller performance over all chiller operating conditions.
- 6) Surge prevention and surge protection algorithms shall take action to prevent surge and move chiller operation away from surge.

b. Enclosure:

- 1) Pre-painted unit mounted, NEMA 1 cabinet shall include hinged, lockable doors and removable lifting lugs.
- 2) VFD shall have a short circuit interrupt and withstand rating of at least 65,000 amps (35,000 amps for 575-v units).
- 3) Provisions to padlock main disconnect handle in the "Off" positions shall be provided. Mechanical interlock to prevent opening cabinet door with disconnect in the "On" position or moving disconnect to the "On" position while the door is open shall be provided.
- 4) Provisions shall be made for top entry of incoming line power cables.

1. BACnet is a registered trademark of ASHRAE (American Society of Heating, Refrigerating, and Air-Conditioning Engineers).

c. Heat Sink:

- 1) The heat sink shall be refrigerant cooled. Heat sink and mating flange shall be suitable for ASME design working pressure of 185 psig (1276 kPa).
- 2) Refrigerant cooling shall be metered by microprocessor control solenoid valve to maintain heat sink temperature within acceptable limits for ambient temperature.
- 3) Water-cooled heat exchangers requiring cleaning shall not be acceptable.

d. VFD Rating:

- 1) Drive shall be suitable for continuous operation at nameplate voltage  $\pm 10\%$ .
- 2) Drive shall be suitable for continuous operation at 100% of nameplate amps and 150% of nameplate amps for 5 seconds.
- 3) Drive shall comply with applicable ANSI, NEMA, UL and NEC standards.
- 4) Drive shall be suitable for operation in ambient temperatures between 40 and 104°F (4.4 and 40°C), 95% humidity (non-condensing) for altitudes up to 6000 ft (1829 m) above sea level. Specific drive performance at jobsite ambient temperature and elevation shall be provided by the manufacturer in the bid.

e. User Interface:

A single display shall provide interface for programming and display of VFD and chiller parameters. Viewable parameters include:

- 1) Operating, configuration and fault messages
- 2) Frequency in Hz
- 3) Load and line side voltage and current (at the VFD)
- 4) kW (line and load side)
- 5) IGBT temperatures

f. VFD Performance:

- 1) VFD voltage total harmonic distortion (THD) and harmonic current total demand distortion (TDD) shall not exceed IEEE-519 requirements using the VFD circuit breaker input terminals as the point of common coupling (PCC).
- 2) VFD full load efficiency shall meet or exceed 97% at 100% VFD rated ampacity.
- 3) Active rectifier shall regulate unity displacement power factor to 0.99 or higher at full load.
- 4) Voltage boost capability to provide full motor voltage at reduced line voltage conditions.
- 5) Soft start, linear acceleration, coast to stop.

- 6) Base motor frequency shall be either 50 or 60 Hz. Adjustable frequency range from 39 to 60 Hz or 32.5 to 50 Hz.

g. VFD Electrical Service (single point power):

- 1) VFD shall have input circuit breaker with minimum 65,000 amp interrupt capacity.
- 2) VFD shall have standard 15 amp branch circuit breaker to provide power for chiller oil pump.
- 3) VFD shall have standard 3 kva control power transformer with circuit breaker provides power for oil heater, VFD controls and chiller controls.
- 4) The branch oil pump circuit breaker and control power transformer shall be factory wired.
- 5) Nameplate voltage shall range between 380 and 460  $\pm 10\%$ , 3 phase, 50/60 Hz  $\pm 2\%$  Hz.

h. Discrete Outputs:

115 v discrete contact outputs shall be provided for field wired:

- 1) Chilled water pump
- 2) Condenser water pump
- 3) Alarm status
- 4) Tower fan low
- 5) Tower fan high

i. Analog Output:

An analog (4 to 20 mA) output for head pressure reference shall be provided. This signal shall be suitable to control a 2-way or 3-way water regulating valve in the condenser piping.

j. Protection (the following shall be supplied):

- 1) Under-voltage
- 2) Over voltage
- 3) Phase loss
- 4) Phase reversal
- 5) Ground fault
- 6) Phase unbalance protection
- 7) Single cycle voltage loss protection
- 8) Programmable auto re-start after loss of power
- 9) Motor overload protection (NEMA Class 10)

k. VFD Testing:

VFD shall be factory mounted, wired and tested on the chiller prior to shipment.

24. Unit-Mounted Variable Frequency Drive (VFD) without Built-In Harmonic Filter (available for low voltage only):

a. Design:

- 1) VFD shall be refrigerant cooled, micro-processor based, pulse width modulated (PWM) design. Water cooled designs are not acceptable.



- 2) Output power devices shall be insulated gate bipolar transistors (IGBTs).
  - 3) Converter section with full-wave fixed diode bridge rectifier shall convert incoming fixed voltage/frequency to fixed DC voltage.
  - 4) DC link shall filter and smooth the converted DC voltage.
  - 5) Transistorized inverter and control regulator shall convert fixed DC voltage to a sinusoidal PWM waveform.
  - 6) Integrated controls shall coordinate motor speed and guide vane position to optimize chiller performance over a wide variety of operating conditions.
  - 7) Surge prevention and surge protection algorithms shall take action to prevent surge and move chiller operation away from surge.
- b. Enclosure:
- 1) Pre-painted, unit mounted NEMA 1 cabinet shall include hinged, lockable doors and removable lifting lugs.
  - 2) VFD shall have a short circuit interrupt and withstand rating of at least 100,000 amps.
  - 3) Provisions to padlock main disconnect handle in the "Off" positions shall be provided. Mechanical interlock to prevent opening cabinet door with disconnect in the "On" position or moving disconnect to the "ON" position while the door is open shall be provided.
  - 4) Provisions shall be made for top entry of incoming line power cables.
- c. Heat Sink:
- 1) The heat sink shall be refrigerant cooled. Heat sink and mating flanges shall be suitable for ASME design working pressure of 185 psig (1276 kPa).
  - 2) Refrigerant cooling shall be metered by integrated standard controls to maintain heat sink temperature within acceptable limits for ambient temperature.
- d. VFD Rating:
- 1) Drive shall be suitable for nameplate voltage  $\pm 10\%$ .
  - 2) Drive shall be suitable for continuous operation at 100% of nameplate amps and 150% of nameplate amps for 3 seconds.
  - 3) Drive shall comply with applicable UL, CE, and NEMA standards.
  - 4) Drive shall be suitable for operation in ambient temperatures between 40 and 104°F (4.4 and 40°C), 95% humidity (non-condensing) for altitudes up to 3300 ft (1006 m) above sea level. Specific drive performance at jobsite ambient temperature and elevation shall be provided by the manufacturer in the bid.
- e. User Interface:
- Displays shall provide interface for programming and display of VFD and chiller parameters. Viewable parameters include:
- 1) Operating, configuration and fault messages
  - 2) Frequency in hertz
  - 3) Load and line side voltage and current (at the VFD)
  - 4) kW (on the VFD interface)
- f. VFD Performance:
- 1) VFD full load efficiency shall meet or exceed 97% at 100% VFD Rated ampacity.
  - 2) Displacement Input Power Factor shall meet or exceed 95% soft start, linear acceleration, coast to stop.
  - 3) Base motor frequency shall be either 50 or 60 Hz. Adjustable frequency range from 38 to 60 Hz or 32.5 to 50 Hz.
- g. VFD Electrical Service (single point power):
- 1) VFD shall have input circuit breaker with minimum 100,000 amp interrupt capacity.
  - 2) VFD shall have standard 15 amp branch oil pump circuit breaker to provide power for chiller oil pump.
  - 3) VFD shall have standard 3 kva control power transformer with circuit breaker provides power for oil heater, VFD controls and chiller controls.
  - 4) The branch oil pump circuit breaker and control power transformer shall be factory wired.
  - 5) Input power shall be 380/480 vac,  $\pm 10$  percent, 3 phase, 50/60 Hz,  $\pm 3$  Hz.
- h. Discrete Outputs:
- 115-v discrete contact outputs shall be provided for:
- 1) Circuit breaker shunt trip
  - 2) Chilled water pump
  - 3) Condenser water pump
  - 4) Alarm status.
- i. Analog Output:
- An analog (4 to 20 mA) output for head pressure reference shall be provided. This signal shall be suitable to control a 2-way or 3-way water regulating valve in the condenser piping.
- j. Protection (the following shall be supplied):
- 1) Under-voltage
  - 2) Over voltage
  - 3) Phase loss
  - 4) Phase reversal
  - 5) Ground fault
  - 6) Phase unbalance protection

- 7) Single cycle voltage loss protection
  - 8) Programmable auto re-start after loss of power
  - 9) Motor overload protection (NEMA Class 10)
  - 10) Motor overtemperature protection
- k. VFD Testing:  
VFD shall be factory mounted, wired and tested on the chiller prior to shipment.
25. Free-Standing Medium Voltage Variable Frequency Drive:
- a. VFD Design:
    - 1) Technology shall allow connection of the drive to utility power without the requirement of an isolation transformer.
    - 2) Direct-to-drive technology shall have active front end to track and regulate input current to maintain sine wave current draw.
    - 3) VFD shall be microprocessor-based, pulse width modulated (PWM) design.
    - 4) Input and output power devices shall be 6500 volt rated symmetrical gate commutated thyristor (SGCT) to achieve superior PWM switching pattern and significantly reduce line current harmonics.
    - 5) Low voltage and medium voltage compartments shall be totally isolated and separated.
    - 6) Power shall be isolated by means of a vacuum starter that can be locked out/tagged out. This starter can be integral to drive for "A" frames, part of line up or located outside of line up for "B" frames.
    - 7) Integrated controls shall coordinate motor speed and guide vane position to optimize chiller performance over a wide variety of operating conditions.
    - 8) Surge prevention and surge protection algorithms shall take action to prevent surge and move chiller operation away from surge.
  - b. Enclosure:
    - 1) Rear access shall not be required and VFD shall be fully accessible from front.
    - 2) Pre-painted cabinet (NEMA 1) includes hinged, lockable doors and removable lifting lugs.
    - 3) Enclosure shall have short circuit interrupt and withstand rating of at least 25,000 amps.
  - c. Heat Sink:
    - 1) The heat sink shall be air-cooled from 200 hp to 5500 hp.
    - 2) Advanced overtemperature compensation algorithm shall provide standard heat sink temperature and flow monitoring.
  - d. VFD Rating:
    - 1) Drives less than 6600 vac shall be suitable for nameplate voltage plus or minus 10%; 6600-vac drives shall have voltage rating of plus 5% and minus 10%.
    - 2) Drive shall be suitable for continuous operation at 100% of nameplate amps and 110% of nameplate amps for 60 seconds every ten minutes; voltage sag of -30%; and control power loss ride through of 5 cycles standard and >5 cycles with optional UPS (uninterruptible power supply).
    - 3) Drive complies with applicable sections of NEMA, UL, and NEC standards and is UL, Canada listed.
    - 4) Drive shall be suitable for operation in ambient temperatures between 40 and 104°F (4.4 and 40°C), 95% humidity (non-condensing) for altitudes up to 3300 ft (1006 m) above sea level. Specific drive performance at jobsite ambient temperature and elevation shall be provided by the manufacturer in the bid.
  - e. VFD Performance:
    - 1) VFD voltage total harmonic distortion (THD) shall not exceed 3% and harmonic current total demand distortion (TDD) shall not exceed IEEE-519 requirements using the VFD circuit breaker input terminals as the point of common coupling (PCC).
    - 2) VFD full load efficiency shall meet or exceed 97% at 100% VFD rated ampacity.
    - 3) Displacement input power factor shall meet or exceed 99% to unity gain at full load.
    - 4) Soft start, linear acceleration, coast to stop.
    - 5) Base motor frequency shall be either 50 or 60 Hz, adjustable frequency range from 39 to 60 Hz or 32.5 to 50 Hz.
  - f. VFD Electrical Service (Single Point Power):  
VFD shall have input circuit breaker with minimum 25,000 amp interrupt capacity.
  - g. Protection (the following shall be supplied):
    - 1) Under voltage
    - 2) Over voltage
    - 3) Phase loss
    - 4) Phase reversal
    - 5) Ground fault
    - 6) Phase unbalance protection
    - 7) Single cycle voltage loss protection
    - 8) Programmable auto restart after loss of power
    - 9) Motor overload protection (NEMA Class 10)
    - 10) Motor overtemperature protection

- h. Testing:  
Drive shall be 100% load tested from VFD manufacturer's factory and shipped without any unwiring or electrical components disassembled inside main VFD cabinet.
- 26. Free-Standing Low Voltage Variable Frequency Drive:
  - a. Design:
    - 1) Output power devices shall be insulated gate bipolar transistors (IGBTs).
    - 2) Converter section with full wave fixed diode bridge rectifier shall convert incoming fixed voltage/frequency to fixed DC voltage.
    - 3) Transistorized inverter and control regulator shall convert fixed DC voltage to a sinusoidal PWM waveform.
    - 4) VFD shall have 1.5% AC line reactor.
  - b. Enclosure:  
Main section and control section shall be housed in connected NEMA 1 cabinets.
  - c. User Interface:  
Door-mounted digital keypad with non-volatile memory shall have 6 line, 30 character

back-lit LCD display for programming and display of VFD parameters. Viewable parameters include:

- 1) Operating, configuration, and fault messages
  - 2) Frequency in Hz
  - 3) Manual or automatic control mode
  - 4) Output frequency
  - 5) Percent output voltage, or voltage
  - 6) Percent output current, or current
  - 7) kW and kWh
- d. VFD Electrical Service:
    - 1) VFD shall have main standard interrupting capacity circuit breaker with shunt trip (65 kAIC interrupt capacity).
    - 2) VFD shall have oil pump circuit breaker (65 kAIC interrupt capacity).
    - 3) VFD shall have pumpout unit circuit breaker (65 kAIC interrupt capacity).
    - 4) 110-v power shall be provided for ISM (integrated starter module) board.
  - e. Analog Output:  
An analog (4 to 20 mA) output for head pressure reference shall be provided.

