



Controls, Start-Up, Operation, Service, and Troubleshooting

CONTENTS

	Page
SAFETY CONSIDERATIONS	2
GENERAL	3
MAJOR SYSTEM COMPONENTS	3,4
Main Base Board (MBB)	3
Auxiliary (AUX) Board	3
Electronic Expansion Valve (EXV) Board	3
Compressor Protection Module (CPM)	3
Energy Management Module (EMM)	3
Enable/Off/Remote Connect Switch	3
Emergency On/Off Switch	3
Board Addresses	3
Control Module Communication	3
Carrier Comfort Network® (CCN) Interface	4
CONTROLS OPERATION	4-38
Electronic Expansion Valve (EXV)	4
• EXV OPERATION	
• ECONOMIZER OPERATION	
Oil Pumps	4
Motor Cooling	5
Back Pressure Valve (30HXA only)	5
Sensors	5
Compressor Protection Module (CPM)	5
Wye-Delta vs Across-the-Line (XL) Starting Option	9
Capacity Control	9
• MINUTES LEFT FOR START	
• MINUTES OFF TIME	
• LOADING SEQUENCE	
• CLOSE CONTROL	
• LEAD/LAG DETERMINATION	
• CAPACITY SEQUENCE DETERMINATION	
• MINIMUM LOAD VALVE	
• CAPACITY CONTROL OVERRIDES	
Head Pressure Control	12
• GENERAL	
• WATER-COOLED UNITS (30HXC)	
• CONDENSERLESS UNITS (30HXA)	
• 09DK AIR-COOLED CONDENSERS	
• 09DP AIR-COOLED CONDENSERS	
• 09AZ AIR-COOLED CONDENSERS	
• OPERATION SEQUENCE	
• VARIABLE SPEED FAN CONTROL	
• ADJUSTING PID ROUTINES	
Control Methods	15
• SWITCH	
• 7-DAY SCHEDULE	
• OCCUPANCY	
• CCN	
Cooling Setpoint Select	15
Ice Mode	15
Cooler and Condenser (30HXC) Pump Control	15
• COOLER PUMP CONTROL	
• CONDENSER PUMP CONTROL	
• Flow Sensor	16
• Navigator™ Display Module Usage	16
• Service Test	17
• Configuring and Operating Dual Chiller Control	17
• Alarms/Alerts	34
• Run Hours and Starts	34
• Temperature Reset	34
• Demand Limit	36
• DEMAND LIMIT (2-Stage Switch Controlled)	
• EXTERNALLY POWERED DEMAND LIMIT	
• DEMAND LIMIT (CCN Loadshed Controlled)	
• Cooling Set Point (4 to 20 mA)	37
TROUBLESHOOTING	39-49
• Checking Display Codes	39
• Unit Shutoff	39
• Complete Unit Stoppage	39
• Single Circuit Stoppage	39
• Restart Procedure	39
• POWER FAILURE EXTERNAL TO THE UNIT	
• Alarms and Alerts	39
• Compressor Alarm/Alert Circuit	39
• EXV Troubleshooting Procedure	48
• INSPECTING/OPENING ELECTRONIC EXPANSION VALVES	
• BRAZED-PLATE ECONOMIZERS	
SERVICE	50-66
• Servicing Coolers and Condensers	50
• TUBE PLUGGING	
• RETUBING	
• TIGHTENING COOLER/CONDENSER HEAD BOLTS	
• Inspecting/Cleaning Heat Exchangers	50
• COOLERS	
• CONDENSERS (30HX Only)	
• Water Treatment	51
• Refrigerant Charging/Adding Charge	51
• Oil Charging/Low Oil Recharging	52
• Oil Filter Maintenance	53
• REPLACING THE EXTERNAL OIL FILTER	
• REPLACING THE INTERNAL OIL FILTER	
• Compressor Changeout Sequence	53
• BURNOUT CLEAN-UP PROCEDURE	
• Moisture-Liquid Indicator	55
• Filter Drier	56
• Liquid Line Service Valve	56
• Thermistors	56
• LOCATION	
• THERMISTOR REPLACEMENT	
• Pressure Transducers	61
• TROUBLESHOOTING	
• Chilled Water Flow Sensor	61
• Safety Devices	63
• COMPRESSOR PROTECTION	

CONTENTS (cont)

	Page
• COOLER PROTECTION	
Relief Devices	63
• PRESSURE RELIEF VALVES	
Control Modules	63
• MAIN BASE BOARD (MBB), AUXILIARY (AUX) BOARD, EXPANSION VALVE BOARD (EXV), ENERGY MANAGEMENT MODULE (EMM), COMPRESSOR PROTECTION MODULE (CPM), AND THE NAVIGATOR™ MODULE	
• RED LED	
• GREEN LED	
• YELLOW LED	
Carrier Comfort Network (CCN) Interface	64
Replacing Defective Processor Module	64
Winter Shutdown Preparation	65
Maintenance	65
PRE-START-UP PROCEDURE	65,66
System Check	66
START-UP AND OPERATION	66
Actual Start-up	66
Operating Sequence	66
FIELD WIRING	67-69
APPENDIX A —	
COMPRESSOR MUST TRIP AMP (MTA) SETTINGS	70-76
APPENDIX B —	
CAPACITY LOADING SEQUENCE	77-79
APPENDIX C — AVAILABLE ACCESSORIES	80
APPENDIX D — COOLER AND CONDENSER PRESSURE DROP	81,82
APPENDIX E —	
TYPICAL SYSTEM COMPONENTS	83-90
APPENDIX F — CCN CONFIGURATION	91-104
APPENDIX G — MAINTENANCE SUMMARY AND LOG SHEET	105-107
APPENDIX H — BACNET COMMUNICATION OPTION	108-118
START-UP CHECKLIST for 30HX Liquid Chiller	CL-1 to CL-10

SAFETY CONSIDERATIONS

Installing, starting up, and servicing this equipment can be hazardous due to system pressures, electrical components, and equipment location (roof, elevated structures, etc.). Only trained, qualified installers and service mechanics should install, start up, and service this equipment.

When working on this equipment, observe precautions in the literature, and on tags, stickers, and labels attached to the equipment, and any other safety precautions that apply. Follow all safety codes. Wear safety glasses and work gloves. Use care in handling, rigging, and setting this equipment, and in handling all electrical components.

WARNING

Electrical shock can cause personal injury and death. Shut off all power to this equipment during installation and service. There may be more than one disconnect switch. Tag all disconnect locations to alert others not to restore power until work is completed.

CAUTION

This unit uses a microprocessor-based electronic control system. Do not use jumpers or other tools to short out components, or to bypass or otherwise depart from recommended procedures. Any short-to-ground of the control board or accompanying wiring may destroy the electronic modules or electrical components.

WARNING

To prevent potential damage to heat exchanger tubes always run fluid through heat exchangers when adding or removing refrigerant charge. Use appropriate brine solutions in cooler and condenser fluid loops to prevent the freezing of heat exchangers when the equipment is exposed to temperatures below 32 F (0° C).

DO NOT VENT refrigerant relief valves within a building. Outlet from relief valves must be vented outdoors in accordance with the latest edition of ANSI/ASHRAE (American National Standards Institute/American Society of Heating, Refrigerating and Air Conditioning Engineers) 15 (Safety Code for Mechanical Refrigeration). The accumulation of refrigerant in an enclosed space can displace oxygen and cause asphyxiation. Provide adequate ventilation in enclosed or low overhead areas. Inhalation of high concentrations of vapor is harmful and may cause heart irregularities, unconsciousness or death. Misuse can be fatal. Vapor is heavier than air and reduces the amount of oxygen available for breathing. Product causes eye and skin irritation. Decomposition products are hazardous.

WARNING

DO NOT USE TORCH to remove any component. System contains oil and refrigerant under pressure.

To remove a component, wear protective gloves and goggles and proceed as follows:

- Shut off electrical power to unit.
- Recover refrigerant to relieve all pressure from system using both high-pressure and low pressure ports.
- Traces of vapor should be displaced with nitrogen and the work area should be well ventilated. Refrigerant in contact with an open flame produces toxic gases.
- Cut component connection tubing with tubing cutter and remove component from unit. Use a pan to catch any oil that may come out of the lines and as a gage for how much oil to add to the system.
- Carefully unsweat remaining tubing stubs when necessary. Oil can ignite when exposed to torch flame.

Failure to follow these procedures may result in personal injury or death.

CAUTION

DO NOT re-use compressor oil or any oil that has been exposed to the atmosphere. Dispose of oil per local codes and regulations. DO NOT leave refrigerant system open to air any longer than the actual time required to service the equipment. Seal circuits being serviced and charge with dry nitrogen to prevent oil contamination when timely repairs cannot be completed. Failure to follow these procedures may result in damage to equipment.

GENERAL

IMPORTANT: These units use refrigerant R-134a. Compressor oil used with R-134a is Emkarate RL220XL.

This publication contains Controls Start-Up, Service, Operation and Troubleshooting data for the 30HXA,C076-271 screw chillers.

Circuits are identified as circuits A and B, and compressors are identified as A1 or A2 in circuit A, and B1 in circuit B.

The 30HX Series chillers feature microprocessor-based electronic controls and electronic expansion valves (EXV) in each refrigeration circuit.

The control system cycles compressor loaders and/or compressors to maintain the selected leaving fluid temperature set point. The system automatically positions the EXV to maintain the specified discharge gas superheat temperature in the circuit. The system also has capabilities to control a condenser water valve to maintain suitable discharge pressure for the 30HXC unit. Safeties are continuously monitored to prevent the unit from operating under unsafe conditions. A scheduling function can be programmed by the user to control the unit's occupied and unoccupied schedules. The control also operates a test function and a manual control function that allows the operator to check output signals and ensure components are operable.

MAJOR SYSTEM COMPONENTS

Main Base Board (MBB) — This board contains the majority of the control system operating software and controls the operation of the machine. The MBB has 11 input channels and 11 output channels.

The MBB continuously monitors input/output channel information received from all the modules and controls all output signals for all output channels. The processor module also controls the EXV driver module, commanding it to open or close each EXV in order to maintain the proper cooler level. Information is transmitted between the MBB; the Compressor Protection Module (CPM), the EXV driver module, the Auxiliary (AUX) Board, the Energy Management Module (EMM) and the Navigator™ modules through a 3-wire communications bus called the Local Equipment Network (LEN). The remote enhanced display is connected to the MBB through a 3-wire communications bus, but uses a different communication bus called the Carrier Comfort Network® (CCN). The CCN bus is also used to communicate to other CCN devices when the unit is installed in a network application.

Auxiliary (AUX) Board — The AUX board provides head pressure control for the 30HXA chiller field-supplied 4 to 20 mA devices and 30HXC chiller field-supplied 4 to 20 mA head pressure control valve. The AUX board receives inputs from the MBB and operates the oil pumps and the motor cooling solenoids.

Electronic Expansion Valve (EXV) Board — The EXV board has 4 inputs and 2 outputs. It receives signals from the MBB and operates the electronic expansion devices. The electronic expansion valve board also sends the MBB the status of its 4 input channels.

Compressor Protection Module (CPM) — The CPM monitors high-pressure switch status, oil pressure, economizer pressure, motor current, and motor temperature for each compressor. Each CPM board controls one compressor. The CPM also communicates any alarm conditions to the MBB.

Energy Management Module (EMM) — The EMM is available as a factory-installed option or as a field-installed accessory. The EMM receives 4 to 20 mA inputs for the temperature reset, cooling set point reset and demand limit

functions. The EMM also receives the switch inputs for the field-installed 2-stage demand limit and ice done functions. The EMM communicates the status of all inputs with the MBB, and the MBB adjusts the control point, capacity limit, and other functions according to the inputs received.

Enable/Off/Remote Contact Switch — The Enable/Off/Remote Contact switch is a 3-position switch used to control the chiller (see Table 1). When switched to the Enable position the chiller is under its own control. Move the switch to the Off position to shut the chiller down. Move the switch to the Remote Contact position and a field-installed dry contact can be used to start the chiller. The contacts must be capable of handling a 24-vac, 20-mA load. In the Enable and Remote Contact (dry contacts closed) positions, the chiller is allowed to operate and respond to the scheduling configuration, CCN configuration and set point data.

Emergency On/Off Switch — The Emergency On/Off switch should only be used when it is required to shut the chiller off immediately. Power to the MBB, EMM, EXV, AUX and Navigator display is interrupted when this switch is off and all outputs from these modules will be turned off.

Table 1 — Unit Mode from Control/Enable/Off/Remote Contact and CCN State

SWITCH POSITION	REMOTE CONTACTS	CCN CONFIGURATION	CCN STATE	UNIT MODE
ENABLE	NR	DISABLE	NR	LOCAL ON
		ENABLE	RUN	CCN ON
OFF	NR	NR	STOP	CCN OFF
			NR	LOCAL OFF
REMOTE CONTACT	OPEN	NR	NR	LOCAL OFF
		DISABLE	NR	LOCAL ON
	CLOSED	ENABLE	RUN	CCN ON
		ENABLE	STOP	CCN OFF

LEGEND

CCN — Carrier Comfort Network
NR — Input Not Read by Processor

NOTE: If the unit is configured for a clock, then the unit is under clock control if it is in an ON mode.

Board Addresses — The Main Base Board (MBB) has an Instance jumper that must be set to '1.' The EXV and EMM boards have 4-position DIP switches that must be set to 'On' for all boards. The CPM address has a 4-position DIP switch. Switches 3 and 4 set the address. The auxiliary board (AUX) has an 8-position DIP switch. Switches 2, 5 and 7 are set to 'ON.'

Control Module Communication

RED LED — Proper operation of the control boards can be visually checked by looking at the red status LEDs (light-emitting diodes). When operating correctly, the red status LEDs should be blinking in unison at a rate of once every 2 seconds. If the red LEDs are not blinking in unison, verify the board address and that correct power is being supplied to all modules. Be sure that the Main Base Board (MBB) is supplied with the current software. If necessary, reload current software. If the problem still persists, replace the MBB. A board LED that is lit continuously or blinking at a rate of once per second or faster indicates that the board should be replaced.

GREEN LED — The MBB has one green LED. The Local Equipment Network (LEN) LED should always be blinking whenever power is on. All other boards have a LEN LED that should be blinking whenever power is on. Check LEN connections for potential communication errors at the board J3 and/or J4 connectors. Communication between modules is accomplished by a 3-wire bus. These 3 wires run in parallel from module to module. The J5 connector on the MBB provides both power and communication directly to the Navigator module.

YELLOW LED — The MBB has one yellow LED. The Carrier Comfort Network (CCN) LED will blink during times of network communication.

Carrier Comfort Network (CCN) Interface — The 30HX chiller units can be connected to the CCN if desired. The communication bus wiring is a shielded, 3-conductor cable with drain wire and is supplied and installed in the field. The system elements are connected to the communication bus in a daisy chain arrangement. The positive pin of each system element communication connector must be wired to the positive pins of the system elements on either side of it. This is also required for the negative and signal ground pins of each system element. Wiring connections for CCN should be made at TB3. Consult the CCN Contractor's Manual for further information.

NOTE: Conductors and drain wire must be 20 AWG (American Wire Gage) minimum stranded, tinned copper. Individual conductors must be insulated with PVC, PVC/nylon, vinyl, Teflon, or polyethylene. An aluminum/polyester 100% foil shield and an outer jacket of PVC, PVC/nylon, chrome vinyl, or Teflon with a minimum operating temperature range of -20 C to 60 C is required. Wire manufactured by Alpha (2413 or 5463), American (A22503), Belden (8772), or Columbia (02525) meets the above mentioned requirements. It is important when connecting to a CCN communication bus that a color-coding scheme be used for the entire network to simplify the installation. It is recommended that red be used for the signal positive, black for the signal negative and white for the signal ground. Use a similar scheme for cables containing different colored wires. At each system element, the shields of its communication bus cables must be tied together. If the communication bus is entirely within one building, the resulting continuous shield must be connected to a ground at one point only. If the communication bus cable exits from one building and enters another, the shields must be connected to grounds at the lightning suppressor in each building where the cable enters or exits the building (one point per building only).

To connect the unit to the network:

1. Turn off power to the control box.
2. Cut the CCN wire and strip the ends of the red (+), white (ground), and black (-) conductors. (Substitute appropriate colors for different colored cables.)
3. Connect the red wire to (+) terminal on TB3, the white wire to COM terminal, and the black wire to the (-) terminal.
4. The RJ-14 CCN connector on TB3 can also be used, but is only intended for temporary connection (for example: a laptop computer running Service Tool).

CONTROLS OPERATION

Electronic Expansion Valve (EXV) — The MBB controls the EXV through the EXV board. The EXV (electronic expansion valve) is a device that contains a linear actuator stepper motor. See Fig. 1.

EXV OPERATION — High-pressure liquid refrigerant enters the valve through the side. A series of calibrated slots are located inside the orifice assembly. As refrigerant passes through the orifice, the pressure drops and the refrigerant changes to a 2-phase condition (liquid and vapor). To control refrigerant flow for different operating conditions, the sleeve moves up and down over the orifice, thereby changing orifice size. The sleeve is moved by a linear stepper motor. The stepper motor moves in increments and is controlled directly by the processor module. As the stepper motor rotates, motion is transferred into linear movement by the lead screw. Through the stepper motor and lead screw, 15,000 discrete steps of motion are obtained. The large number of steps and long stroke result in very accurate control of refrigerant flow.

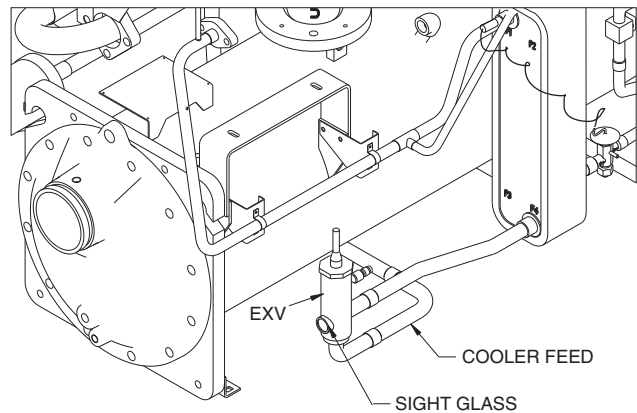

Fig. 1 — Electronic Expansion Valve (EXV)

Each compressor has a discharge gas temperature sensor mounted vertically in the top of the muffler assembly. The discharge gas temperature sensor monitors the discharge gas temperature leaving each compressor and sends this information to the MBB through LEN communication with the EXV board. At initial start-up, the EXV position is at zero. After that, the microprocessor keeps accurate track of the valve position in order to use this information as input for the other control functions. The processor does this by initializing the EXVs at start-up. The processor sends out enough closing pulses to the valve to move it from fully open to fully closed, then resets the position counter to zero. From this point, until the next initialization, the processor counts the total number of open and closed steps it has sent to each valve.

ECONOMIZER OPERATION — Economizers are factory installed on 30HXA,C161-271 units. All other sizes use standard EXVs. The economizer is a brazed plate heat exchanger designed to improve chiller capacity and efficiency as well as providing compressor motor cooling. See Fig. 2. On 30HXA,C chillers the economizer is active all the time.

Liquid refrigerant is supplied from the condenser to the top of the economizer. As the refrigerant passes through the economizer, its pressure is reduced to an intermediate level. Next, the refrigerant flows to the EXV which regulates flow to the cooler to maintain the discharge superheat setpoint.

The increase in performance is achieved by diverting a small amount of liquid through a thermostatic expansion valve to a second circuit in the brazed-plate heat exchanger. This will further subcooling the liquid in the first circuit as the refrigerant flashes to vapor. This increase in subcooling provides additional capacity. Also, since the additional power required to accomplish this is minimal; the efficiency of the machine improves. The vapor that flashes leaves the top of the economizer where it passes to the compressor and is used to provide motor cooling. After passing over the motor windings, the refrigerant reenters the cycle at an intermediate port in the compression cycle.

Oil Pumps — The 30HX screw chillers use one externally mounted prelubricating oil pump per circuit. This pump is operated as part of the start-up sequence. The pumps are mounted to a bracket on the condensers of 30HXC units and to the oil separator on 30HXA units. See Fig. 3.

When a circuit is required to start, the controls energize the oil pump first and read the oil pressure transducer reading. The pump is operated for a period of 20 seconds, after which the oil solenoid is energized to open the oil inlet valve at the compressor. The control again reads the pressure from the oil pressure transducer. If the pump has built up sufficient oil pressure, the compressor is allowed to start after 15 seconds.

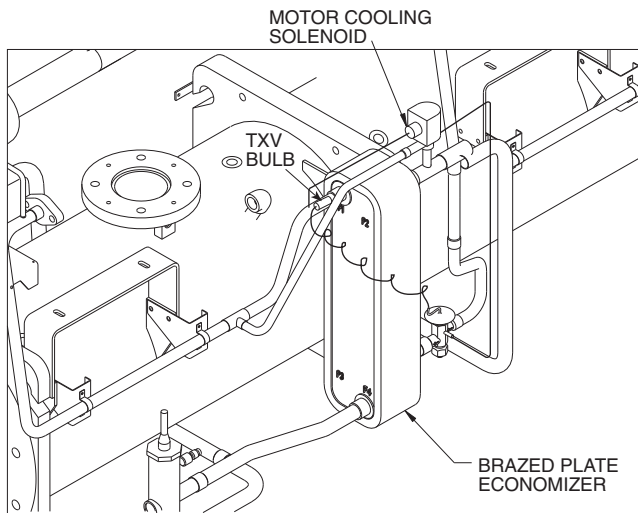

Fig. 2 — Braze Plate Economizer

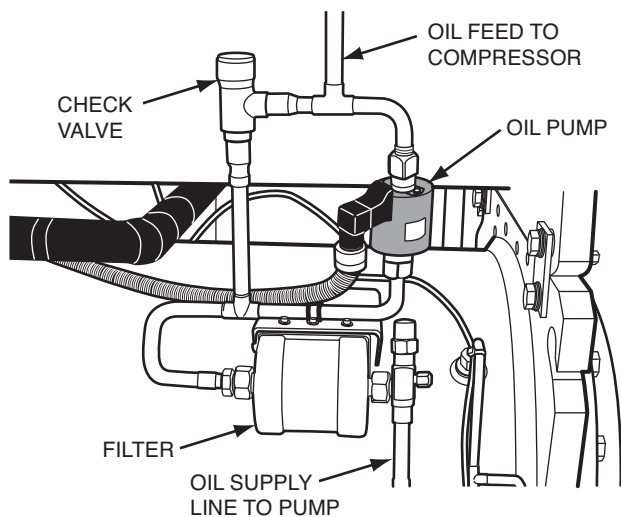

Fig. 3 — Oil Pump

Once the compressor has started, the oil pump will continue to run for 120 seconds.

If the pump is unable to build up enough oil pressure, the pump is turned off. Within 3 seconds, the pump is re-energized and makes two additional attempts, if necessary, to build oil pressure. The control generates an alarm if the third attempt fails.

The oil pump is also used to supplement system pressure under certain operating conditions. The oil flow requirements of the compressor vary based on pressure differential across the compressor. The oil pump is designed to provide differential oil pressure during low pressure differential conditions. It is not designed to overcome high pressure drop across filters during high pressure differential conditions.

If the differential oil pressure (oil pressure – economizer pressure) for a compressor is too low the oil pump will be started. Just before the oil pump is started the control measures the pressure differential between the discharge pressure and oil pressure (oil system pressure drop). The oil system pressure drop is saved and used to determine when the oil pump should be shut off.

When the oil pump is operating, it is capable of increasing oil pressure from 0 psi to 50 psi depending on the oil flow requirements of the compressor. For example, if the compressor needs 2 gpm (high pressure differential condition) and the oil pump is capable of 1.2 gpm, there is no pressure rise and

the oil flow will bypass the check valve and supply the 2 gpm to the compressor. If the compressor requires .75 gpm, the oil pump will increase pressure to satisfy the oil pressure requirement.

The pump will continue to operate until the discharge pressure minus economizer pressure is greater than 17 psi plus the oil system pressure drop.

Example:

Discharge pressure	80 psi
Oil pressure	65 psi
Oil system pressure drop	80 – 65 = 15 psi
Economizer pressure	55 psi
Differential oil pressure	(65 – 55) = 10 psi
Suction pressure	40 psi

Based on the above conditions the oil pump will be started because differential oil pressure equals 10 psi. See Table 2.

Table 2 — Oil Pump Suction Pressure Requirements

SUCTION PRESSURE (SP)	OIL PUMP TURNS ON WHEN DIFFERENTIAL PRESSURE IS LESS THAN:
≤ 35 psig	12 psig
35 psig < SP < 51 psig	14.5 psig
≥ 51 psig	17 psig

The oil pump will continue to operate until the discharge pressure minus economizer pressure (which equals 25) is greater than 17 plus 15 (oil system loss before pump was started). The only way this can be satisfied is if the discharge pressure increases or the compressor unloads at which point the oil pump will be shut off.

Motor Cooling — Compressor motor winding temperatures are controlled to a set point of 200 F (93.3 C) or 170 F (76.7 C) for brine applications. The control accomplishes this by cycling the motor cooling solenoid valve to allow liquid refrigerant to flow across the motor windings as needed. All refrigerant used for motor cooling reenters the rotors through a port located midway along the compression cycle and is compressed to discharge pressure.

Back Pressure Valve (30HXA only) — This valve is mounted on the oil separator shell of 30HXA units. The valve's function is to ensure that there is sufficient system differential pressure to allow for oil to be driven back to the compressor. A small copper line (economizer pressure) is connected to the top of the valve, which contains an internal spring that closes a piston if the pressure in the oil separator is not at least 15 psig greater than the economizer pressure.

Sensors — The 30HX *ComfortLink*™ control system gathers information from sensors to control the operation of the chiller. The units use up to 10 standard pressure transducers and up to 10 standard thermistors (including 4 motor temperature thermistors). The sensors are listed in Table 3.

Compressor Protection Module (CPM) — There is one CPM per compressor. See Fig. 4. The device controls the compressor contactor, oil solenoid, and the economizer solenoid if present. The CPM also monitors the compressor motor temperature, high pressure switch, oil pressure transducer, motor current, MTA setting and economizer pressure transducer. The CPM responds to commands from the MBB (Main Base Board) and sends the MBB the results of the channels it monitors via the LEN (Local Equipment Network). The CPM has three DIP switch input banks, Switch 1 (S1), Switch 2 (S2), and Switch 3 (S3). The CPM board S1 DIP switch configures the board for the type of starter, the location and size of the current transformer and contactor failure instructions. See Table 4 for description of DIP switch 1 (S1) inputs. See Table 5 for

CPM inputs and outputs. See Appendix A for DIP switch settings.

The CPM board DIP switch S2 setting determines the must trip amps (MTA) setting. See Appendix A for DIP switch set-

tings. The MTA setting which is calculated using the settings S2 must match the MTA setting in the software or an MTA alarm will be generated.

Table 3 — Thermistor and Transducer Locations

THERMISTORS			
Sensor	Description	Location	Connection Terminals
T1	Cooler Leaving Fluid Temp	Cooler Head Leaving Fluid Side	MBB, J8-13,14
T2	Cooler Entering Fluid Temp	Cooler Head Entering Fluid Side	MBB, J8-11,12
Motor Temp A1	Motor Temperature A1	Compressor A1 Junction Box	CPM-A1, J9-CH1
Motor Temp A2*	Motor Temperature A2	Compressor A2 Junction Box	CPM-A2, J9-CH1
Motor Temp B1	Motor Temperature B1	Compressor B1 Junction Box	CPM-B1, J9-CH1
T5	Discharge Gas Temp Comp A1	Top of Comp A1 Discharge Line	EXV, J5-11,12
T6	Discharge Gas Temp Comp B1	Top of Comp B1 Discharge Line	EXV, J5-9,10
T3*	Discharge Gas Temp Comp A2	Top of Comp A2 Discharge Line	EXV, J5-7,8
T9 (optional)†	Outdoor Air Thermistor/Dual LWT	Outside Air Stream/Common Leaving Fluid	TB5, terminals 7,8
T10 (optional)†	Space Temperature	Conditioned Space	TB5, terminals 5,6
COND EWT (optional)†	Condenser Entering Water Thermistor	Condenser Entering Fluid Line	TB2, terminals 1,2
COND LWT (optional)†	Condenser Leaving Water Thermistor	Condenser Leaving Fluid Line	TB2, terminals 3,4
PRESSURE TRANSDUCERS			
Sensor	Description	Location	Connection Terminals
DPT-A	Discharge Pressure Circuit A	Top of Condenser Separator Circuit A	MBB, J8-21,22,23
SPT-A	Suction Pressure Circuit A	Top of Cooler Circuit A	MBB, J8-24,25,26
EPT-A	Economizer Pressure Circuit A	Economizer Line Entering Comp A	CPM-A1-J10A
OPT-A1	Oil Pressure Compressor A1	Compressor A1 Oil Connection	CPM-A1-J10B
OPT-A2*	Oil Pressure Compressor A2	Compressor A2 Oil Connection	CPM-A2-J10B
DPT-B	Discharge Pressure Circuit B	Top of Oil Separator Circuit B	MBB, J8-15,16,17
SPT-B	Suction Pressure Circuit B	Top of Cooler Circuit B	MBB, J8-18,19,20
EPT-B	Economizer Pressure Circuit B	Economizer Line Entering Comp B	CPM-B1-J10A
OPT-B1	Oil Pressure Compressor B1	Compressor B1 Oil Connection	CPM-B1-J10B

*30HX206-271 only.

†Sensors are available as accessories for field installation (30HXC only).

Table 4 — DIP Switch 1 (S1) Inputs

DIP SWITCH POSITION	FUNCTION	SETTING	MEANING
1	Starter Configuration	OFF	Across-the-line Start
		ON	Y-Delta Start
2, 3	Current Transformer (CT) Position	OFF, OFF	CT is located in the Delta of the motor
		ON, OFF	CT is located in the main line
		OFF, ON	Reserved for future use
		ON, ON	Invalid; will cause MTA configuration alarm
4,5,6	Current Transformer (CT) Selection	OFF, OFF, OFF	100A/1V CT1
		ON, OFF, OFF	100A/0.503V CT2
		OFF, ON, OFF	100A/0.16V CT3
		OFF, ON, ON	Invalid; will cause MTA configuration alarm
		ON, OFF, OFF	Invalid; will cause MTA configuration alarm
		ON, OFF, ON	Invalid; will cause MTA configuration alarm
		ON, ON, OFF	Invalid; will cause MTA configuration alarm
		ON, ON, ON	Invalid; will cause MTA configuration alarm
7	Contactor Failure Action	OFF	All units should be off
		ON	Used when Shunt Trip is available in the unit
8	Not Used	-	-

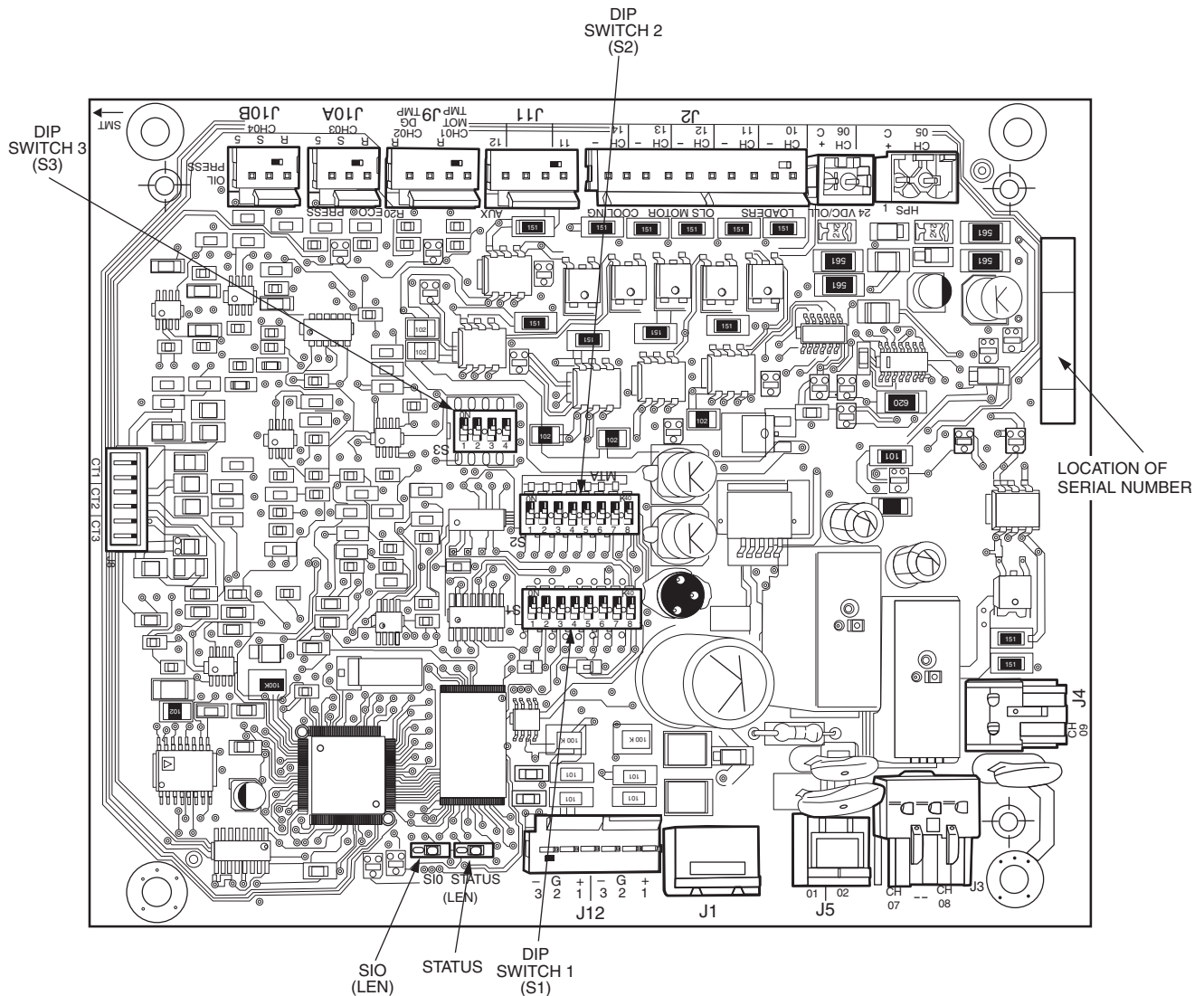

Fig. 4 — Compressor Protection Module

See below for CPM board S3 address information. See Table 5 for CPM inputs and outputs.

CPM-A1 DIP Switch	1	2	3	4
Address:	OFF	OFF	OFF	OFF
CPM-B1 DIP Switch	1	2	3	4
Address:	OFF	OFF	ON	OFF
CPM-A2 DIP Switch	1	2	3	4
Address:	OFF	OFF	OFF	ON

NOTE: The CPM-A1 and CPM-B1 DIP switches are for all units. The CPM-A2 DIP switches are for 30HXA,C 206-271 units.

To verify proper must trip amps setting, use the Navigator™ module and the Configuration mode portion of Appendix A to locate the items CM.A1, CM.A2, and CM.B1 in the UNIT sub-mode. See Appendix A for correct settings. If the values do not match those in Appendix A, verify the S2 DIP switch settings.

The CPM communicates on the LEN (Local Equipment Network) bus to the MBB. Proper operation of the CPM board can be verified by observing the 2 LEDs located on the board.

The red LED blinks at a rate of once every 1 to 2 seconds. This indicates that the module is powered and operating correctly. The green LED blinks when the module is satisfactorily communicating with the MBB. The CPM communicates status of its inputs and outputs and reports 13 different alarm conditions to the MBB.

CAUTION

The CPM module has many features that are specifically designed to protect the compressor, including reverse rotation protection. Do not attempt to bypass or alter any of the factory wiring. Any compressor operation in the reverse direction will result in a compressor failure that will require compressor replacement.

The MBB will generate an alert when it receives an alarm input from the CPM. The alert will be generated as T051, T052, T055, or T056 (for Compressors A1, A2, B1, B2 respectively). Press the **ENTER** and **ESCAPE** buttons on the Navigator simultaneously to expand the full meaning of the alert. For example, the Navigator will read: T055 CIRCUIT B, COMPRESSOR 1 FAILURE-HIGH PRESSURE SWITCH TRIP.

Table 5 — Compressor Protection Module Inputs and Outputs*

DESCRIPTION	INPUT/OUTPUT	I/O TYPE	NAVIGATOR™ MODULE POINT NAME	CONNECTION POINT	
				Pin	Notation
Power (24 VAC supply)	-	-	-	CPM-X-J1	
				11	24 VAC
				12	Ground
Local Equipment Network	-	-	-	CPM-X-JP12	
				1	+
				2	G
				3	-
				CPM-X-J12	
				1	+
2	G				
Circuit X High Pressure Switch	HPS-X	Switch	Not available	CPM-X-J7-CH05	
				1	
				2	
				1	
Must Trip Amps	MTA	8-Pin DIP Switch			
Configuration Switch	SW1	4-Pin DIP Switch	Not available		
Compressor X Motor Temperature	MTR-X	NTC Thermistor		CPM-X-J9-CH01	
				1	
				2	
				1	
Oil Pressure Transducer	OPT X	Pressure Transducer		CPM-X-J10B-CH04	
				5V	+ , 5 VDC ref
				S	Signal
				R	Return
Economizer Pressure Transducer	EPT X	Pressure Transducer		CPM-X-J10A	
				5V	+ , 5 VDC ref
				S	Signal
				R	Return
Compressor Current X Phase A		Current Sensor	Not available	CPM-X-J8-CH01	
				1	
Compressor Current X Phase B		Current Sensor		CPM-X-J8-CH02	
				1	
Compressor Current X Phase C		Current Sensor	Not available	CPM-X-J8-CH3	
				1	
Compressor X 1M Contactor	C X 1M	Contactor		CPM-X-J1-CH07	
				1	
Compressor X 2M Contactor	C X 2M	Contactor	Not available	CPM-X-J2-CH8	
				1	
Compressor X S Contactor	C X S	Contactor	Not available	CPM-X-J2-CH9	
				1	
Oil Heater Relay X	Oil HTR X	Contactor	Not available	CPM-X-J2-CH10	
				1	
Oil Solenoid X	Oil solenoid-X	Solenoid		CPM-X-J2-CH12	
				1	
				2	

*"X" denotes the compressor A1, B1 or A2.
See Appendix A for MTA settings.

If the high-pressure switch opens during operation, all compressor control outputs on the CPM are deenergized and the compressor is stopped. The failure is reported to the MBB and the processor module locks off the compressor from restarting until the alarm is manually reset.

Wye-Delta vs Across-the-Line (XL) Starting Option

All 30HX chillers operating at voltages of 230-3-60, 208/230-3-60 or 230-3-50 (4, 5, or 8 at Position 12 in model number) are supplied with factory-installed Wye-Delta starters. All other voltage options can be ordered with either Wye-Delta or XL starting options. The XL starting method is the most cost effective and simply starts the compressor motor in a Delta configuration (the motors are designed for continuous operation in this configuration) using a single contactor. See Fig. 5. This is the simplest starting method to use and is ideal where starting current does not require limiting.

Where current limitations exist, the Wye-Delta option may be used. See Fig. 6. This option uses a factory-installed starter assembly for each compressor, which consists of 3 contactors labelled 1M, 2M, and S. As the compressor is started, the CPM energizes contactors 1M and S, which connects and energizes the motor windings in a Wye configuration. The starting current required will be approximately 60% less than that required

for an XL start due to the higher impedance of the motor windings when Wye connected. The compressor will attain about 100% of its normal operating speed (approximately 3 to 5 seconds) before the CPM deenergizes the S contactor and energizes the 2M contactor, switching the compressor windings to a Delta wiring configuration. The S and 2M contactors in the starter assembly are both mechanically and electrically interlocked so that they will not both be energized at the same time.

Do not alter the factory-installed power wiring from the control box terminal block to the compressor junction block. Doing so will cause permanent damage to the compressor and will require that the compressor be replaced.

Capacity Control — The control system cycles compressors, loaders, and minimum load control valves to maintain the user-configured leaving chilled fluid temperature set point. Entering fluid temperature is used by the microprocessor to determine the temperature drop across the cooler and is used in determining the optimum time to add or subtract capacity stages. The chilled fluid temperature set point can be automatically reset by the return fluid temperature, space temperature or outdoor-air temperature reset features. It can also be reset from an external 4 to 20 mA signal (requires optional EMM), or from a network signal.

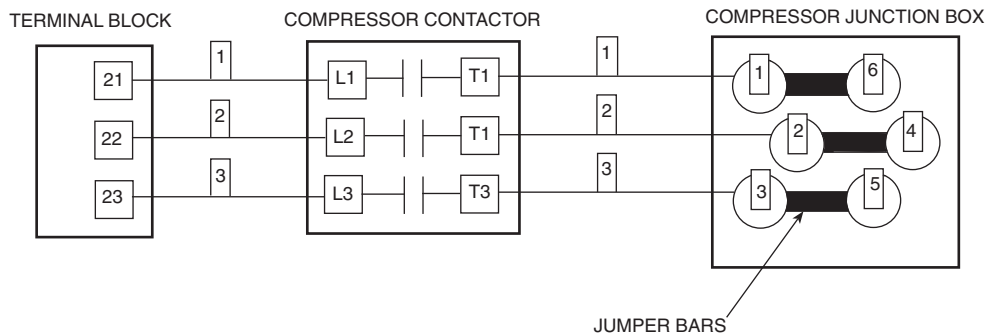

Fig. 5 — Across-the-Line (XL) Compressor Wiring

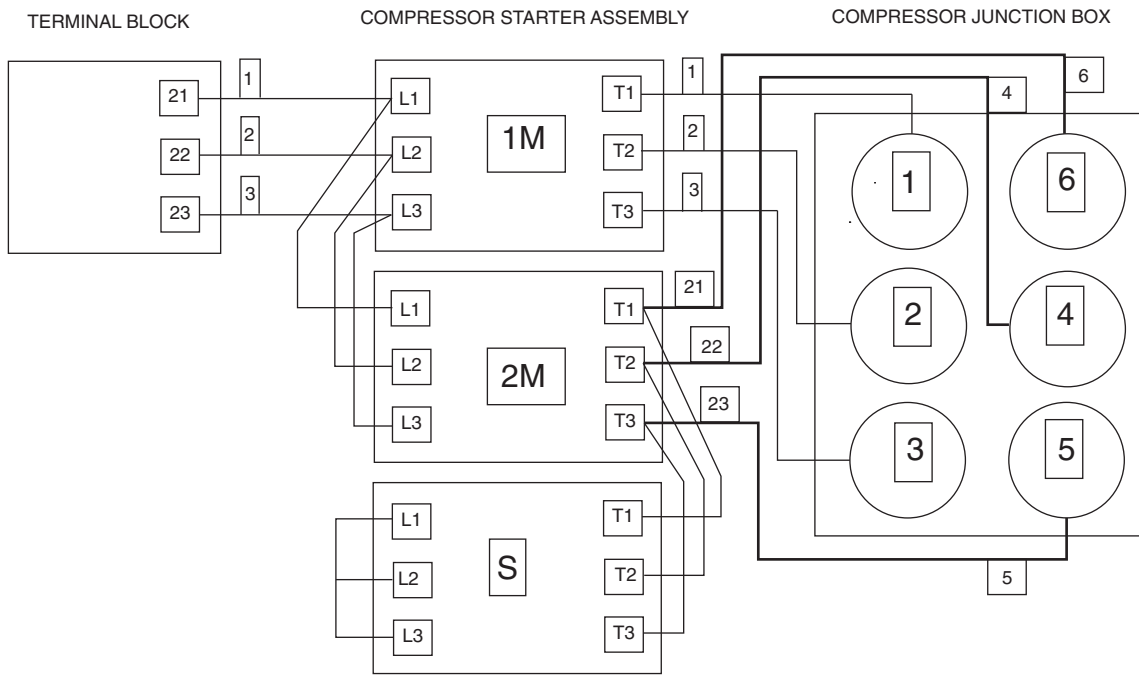

Fig. 6 — Wye-Delta Compressor Wiring

The capacity control algorithm runs every 30 seconds. The algorithm attempts to maintain the Control Point at the desired set point. Each time it runs, the control reads the entering and leaving fluid temperatures. The control determines the rate at which conditions are changing and calculates 2 variables based on these conditions. Next, a capacity ratio (SMZ, Outputs under Sub-mode GEN.O) is calculated using the 2 variables to determine whether or not to make any changes to the current stages of capacity. This ratio value ranges from -100 to + 100%. If the next stage of capacity is a compressor, the control starts (stops) a compressor when the ratio reaches + 100% (-100%). If the next stage of capacity is a loader, the control energizes (deenergizes) a loader when the ratio reaches + 60% (-60%). Loaders are allowed to cycle faster than compressors, to minimize the number of starts and stops on each compressor. A delay of 90 seconds occurs after each capacity step change.

MINUTES LEFT FOR START — This value is displayed in the Status subfunction and represents the amount of time to elapse before the unit is started. This value can be zero without the machine running in many situations. This can include being unoccupied, Remote Contact/Off/Enable switch in the OFF position, CCN not allowing unit to start, Demand Limit in effect, no call for cooling due to no load, and alarm or alert conditions present. If the machine should be running and none of the above are true, a minimum off time may be in effect. The machine should start normally once the time limit has expired.

MINUTES OFF TIME (DELY, Configuration mode under sub-mode OPT2) — This user-configurable time period is used by the control to determine how long unit operation is delayed after power is applied/restored to the unit. Typically, this time period is configured when multiple machines are located on a single site. For example, this gives the user the ability to prevent all the units from restarting at once after a power failure. A value of zero for this variable does not mean that the unit should be running.

LOADING SEQUENCE — The 30HX compressor efficiency is greatest at full load. Therefore, the following sequence list applies to capacity control.

1. The next compressor is not started until all others are running at 100%.
2. The second unloading stage is only used during initial capacity staging of the unit at start-up.
3. Whenever a compressor is started in a circuit, the loaders in the circuit are deenergized for 15 seconds before the compressor is started. The loaders are energized 90 seconds after the compressor is started.

CLOSE CONTROL (CLS.C, Configuration mode under sub-mode OPT2) — When configured for Close Control, the control is allowed to use any loading/capacity control devices required to maintain better leaving fluid temperature regulation. All stages of unloading are available. See Appendix B for an example.

LEAD/LAG DETERMINATION (LLCS, Configuration mode under sub-mode OPT2) — This is a configurable choice and is factory set to be automatic. The value can be changed to Circuit A or Circuit B leading, as desired. Set at automatic, the circuit with the lowest hours is started first. Changes to which circuit is the lead circuit and which is the lag are made when shutting off compressors.

On 30HX206-271 units set for staged loading, the control fully loads the lead circuit before starting the lag circuit and unloads the lag circuit first. When these units are set for equal loading, the control maintains nearly equal capacities in each circuit when the chiller is loading and unloading.

CAPACITY SEQUENCE DETERMINATION (LOAD, Configuration mode, under sub-mode OPT2) — This is configurable as equal circuit loading or staged circuit loading with the default set at staged. The control determines the order in which the steps of capacity for each circuit are changed. This

control choice does NOT have any impact on machines with only 2 compressors.

MINIMUM LOAD VALVE (MLVS, Configuration mode under sub-mode OPT1) — When this option is installed and configured, the first stage of capacity is altered by energizing the Minimum Load valve relay. Once the control requires more capacity, the minimum load valve is deenergized and normal capacity staging resumes with loaders and compressors. Similarly, the Minimum Load valve relay will be energized for the last stage of capacity to be used before the circuit is shut down.

Configure Unit for Minimum Load Control — The chiller must be configured for minimum load control operation. This may be done using the Navigator. Set the Enable/Off/Remote Contact switch in the Off position.

1. Press until 'Select a Menu Item' is displayed.
2. Press to illuminate the Configuration mode LED.
3. Press and to select 'OPT1'. Press and then to select 'MLV'.
4. Press and enter the Password (use arrow keys and press for each digit) if required.
5. Use to change the flashing 'No' to 'Yes'. Press and the display says 'MLV Yes'.

The chiller is now configured for minimum load valve control.

Test Minimum Load Relay Outputs — After the unit is configured, test the operation of the relay and solenoid valve using the Service Test mode.

1. Switch the Enable/Off/Remote Contact switch to the 'Off' position.
2. Press on the Navigator to display 'Select a Menu Item' and press to illuminate the Service Test LED.
3. Press and 'TEST OFF' will be displayed.
4. Press (enter Password if required), and then to display 'TEST ON'.
5. Switch the EOR (Enable/Off/Remote Contact) switch to the "Enable" position.
6. Press to select 'COMP' and press .
7. Press to select 'MLV OFF'. Press followed by and again. The minimum load valve output will be turned on. Both circuits' solenoids are turned on at the same time.
8. Press , followed by and again to turn the valve output off.

Adjust Setting of Minimum Load Ball Valve — The minimum load ball valve must be adjusted to suit the application. Calibrate one circuit at a time as follows:

1. Adjust the ball valve so that it is approximately half open.
2. Operate the chiller in Service Test mode, with one circuit operating, and all compressor loaders deenergized.
3. Record the cooler ΔT (the difference between cooler entering fluid temperature and cooler leaving fluid temperature) at this fully unloaded condition.
4. Use the Service Test feature to enable the minimum load valve for the circuit that is operating.
5. Observe and record the cooler ΔT with the minimum load valve energized.

- Adjust the minimum load ball valve until the cooler temperature difference reading from Step 5 is equal to half of the temperature difference reading from Step 3.
- Open the ball valve to decrease the temperature difference or close the ball valve to increase the temperature difference (ΔT). When the valve is adjusted correctly, the difference between cooler entering and leaving fluid temperatures when the minimum load control is energized must be at least half of the temperature difference when the minimum load control is deenergized. For example, if the difference between the cooler entering and leaving water temperature is 3°F with the valve deenergized, then the difference between cooler entering and leaving water temperature must be at least 1.5°F with the valve energized.

Once the outputs have been tested and the ball valve adjusted, the installation is complete. Disable manual control and return chiller to desired operational status.

CAPACITY CONTROL OVERRIDES — The following overrides will modify the normal operation of the routine.

Deadband Multiplier — The user configurable Deadband Multiplier (Z.GN, Configuration mode under sub-mode SLCT) has a default value of 2.0. The range is from 1.0 to 4.0. When set to other than 1.0, this factor is applied to the capacity Load/Unload Factor. The larger this value is set, the longer the control will delay between adding or removing stages of capacity. Figure 7 shows how compressor starts can be reduced over time if the leaving water temperature is allowed to drift a larger amount above and below the set point. This value should be set in the range of 3.0 to 4.0 for systems with small loop volumes. The Main Base Board (MBB) closely follows the rate of compressor cycling for each circuit.

First Stage Override — If the current capacity stage is zero, the control will modify the routine with a 1.2 factor on adding the first stage to reduce cycling. This factor is also applied when the control is attempting to remove the last stage of capacity.

Slow Change Override — The control prevents the capacity stages from being changed when the leaving fluid temperature is close to the set point (within an adjustable deadband) and moving towards the set point.

Ramp Loading — (RL.S, Configuration mode under sub-mode SLCT) — Limits the rate of change of leaving fluid

temperature. If the unit is in a Cooling mode and configured for Ramp Loading, the control makes 2 comparisons before deciding to change stages of capacity. The control calculates a temperature difference between the control point and leaving fluid temperature. If the difference is greater than 4°F (2.2°C) and the rate of change ($^{\circ}\text{F}$ or $^{\circ}\text{C}$ per minute) is more than the configured Cooling Ramp Loading value (CRMP, Configuration mode under sub-mode SLCT), the control does not allow any changes to the current stage of capacity.

Low Entering Fluid Temperature Unloading — When the entering fluid temperature is below the control point, the control will attempt to remove 25% of the current stages being used. If exactly 25% cannot be removed, the control removes an amount greater than 25%, but no more than necessary. The lowest stage will not be removed.

Low Discharge Superheat — If a circuit's discharge superheat is less than 15°F (8.3°C), the control does not increase the current capacity stage. If the discharge superheat is less than 5°F (2.8°C) and decreasing, the circuit is unloaded every 30 seconds until the superheat is greater than 5°F (2.8°C). The final capacity stage is not unloaded unless an alarm condition exists. This override is ignored for the first 3 minutes after a compressor is started.

Low Saturated Suction Temperature — To avoid freezing the cooler, the control will compare the circuit Saturated Suction temperature with a predetermined freeze point.

For water [brine] circuits, if the Saturated Suction temperature falls below 34°F (1.1°C) [the Brine Freeze Point], the unit capacity will not increase. If the Saturated Suction temperature falls below 28°F (-2.2°C), [the Brine Freeze Point minus 6°F (3.3°C)], for 90 seconds, all loaders in the circuit are turned off. If this condition continues for a total of 3 minutes, the circuit will alarm and shut down.

For Brine applications, the Brine Freeze Point (Configuration Mode, SERV sub-mode, BR.FZ) must be configured for the freeze point of the brine solution. The control will use the Brine Freeze Point value minus 6°F (3.3°C) as the point to compare with the Saturated Suction Temperature. The default for the Brine Freeze Point is 34°F (1.1°C), which means the control will use 28°F (-2.2°C) as the freeze point. The Brine Freeze Point is adjustable from -20°F (-29°C) to 34°F (1.1°C). Failure to set the Brine Freeze Point correctly will cause improper unit operation.

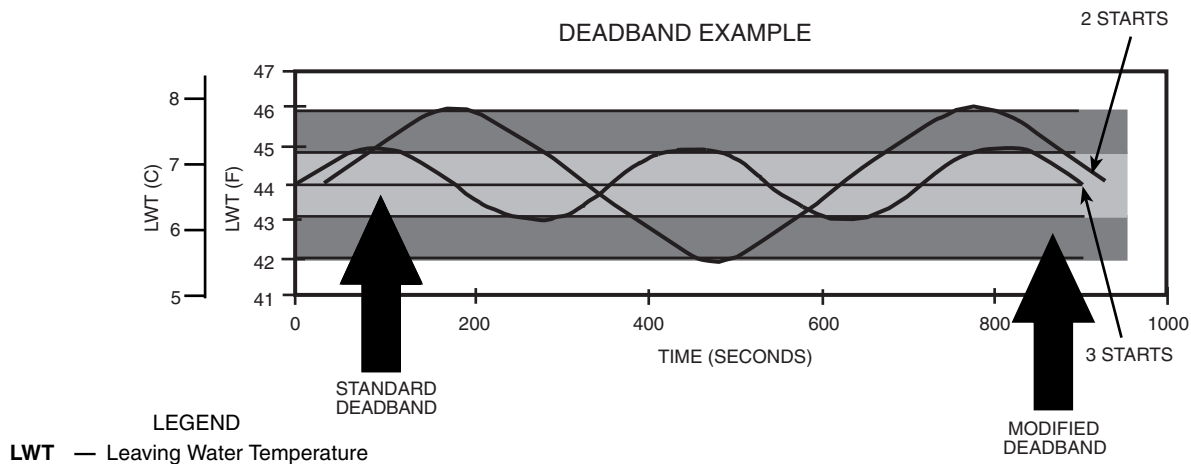

Fig. 7 — Deadband Multiplier

High Condensing Temperature Unloading — Every 10 seconds the control checks for the conditions below. Loaders will be cycled as needed to control the saturated condensing temperature below the configured maximum condensing temperature. Configured maximums are 145 F (62.8 C) for 30HXA, and 118 F (47.8 C) for 30HXC units. If a circuit's saturated condensing temperature is more than 12° F (6.7° C) below the maximum condensing temperature, the circuit capacity is not allowed to increase. If the saturated condensing temperature is more than 2° F (1.1° C) above the maximum condensing temperature for 60 seconds, a loader is turned off. If the saturated condensing temperature rises to more than 5° F (2.8° C) above the maximum condensing temperature during the 60 seconds, a loader is turned off immediately. If all the loaders were already off, the compressor is shut down and an alarm is generated.

MOP (Maximum Operating Pressure) Override — The control monitors saturated condensing and suction temperature for each circuit as well as differential oil pressure. Based on a configurable maximum operating set point (saturated suction temperature), set maximum condensing temperature, and minimum differential oil pressure, the control may reduce the number of capacity stages being used and/or may lower the EXD position when system pressures approach the set parameters.

Head Pressure Control

GENERAL — The 30HXA condenserless units with an 09DK,DP condenser use a combination of factory-supplied fan cycling pressure switches (shipped in the 30HXA control box), temperature switches, and an accessory Motormaster® control to maintain head pressure independent of 30HXA unit control. On 30HXC water-cooled units, the fans are water valve controlled based on each circuit's saturated condensing temperature and compressor status. Water-cooled units (30HXC) operating at less than 70 F (21.1 C) for entering condenser water require the use of head pressure control.

The chiller must be field configured for the options shown in Table 6.

WATER-COOLED UNITS (30HXC) — The 30HXC chiller can be configured to control direct acting water valves that are controlled by a 4 to 20 mA (2 to 10 vdc) signal. A 0 to 20 mA (0 to 10 vdc) or 20 to 0 mA (10 to 0 vdc) can also be configured. Installing a 500-ohm 1/2 watt resistor across the 2 output terminals of the mA signal enables the use of the vdc signal. Set this configuration (VHPT, Configuration mode under sub-mode OPT1) to 1 (4 to 20 mA or 2 to 10 vdc), 2 (0 to 20 mA or 0 to 10 vdc), or 3 (20 to 0 mA or 10 to 0 vdc) as desired depending on valve type. Signal connections are made at terminal block TB2, terminals 14 and 15. The control scheme reads the saturated condensing temperature and uses a PID (proportional integral derivative) loop to control the head pressure. Proportional, Integral and Derivative gain parameters for the

water-cooled controls are adjustable and can be found in the SERV sub-mode under the Configuration mode. Only certified Carrier Comfort Network® technicians should perform check-out and adjustment of the PID loop.

CONDENSERLESS UNITS (30HXA) — The 30HXA unit is often applied with an 09 Series air-cooled condenser. The remote condenser fans are controlled by 2 relay outputs. These connections are in the 30HXA control box. See Field Wiring section on page 67 for wiring details. The 30HXA control must be configured to turn the condenser fans on and/or off. To set the 30HXA control for this configuration, Unit Type (TYPE, Configuration mode under sub-mode UNIT) must be configured to 3 (Split System). The Head Pressure Control Type (HPCT under sub-mode OPT1) must be configured to 1 (air-cooled), and Condenser Pump control must be set to 0 (CNPC must be set to No control, Configuration mode under sub-mode OPT1).

Low ambient head pressure control can be accomplished with fan cycling pressure switches and Motormaster® control. The Motormaster V control also requires a pressure transducer input or the 4 to 20 mA output signal from the *Comfortlink™* control system. See accessory installation instructions for further information.

The Head Pressure Control Type (HPCT under sub-mode OPT1) may be set to control various types of head pressure control devices. HPCT may be set to 0 (No Control), 1 (Air Cooled), 3 (Common Condenser), or 4 (Independent Condenser).

The 30HXA chillers also support the use of a 4 to 20 mA (2 to 10 vdc), 0 to 20 mA (0 to 10 vdc), or 20 to 0 mA (10 to 0 vdc) for fan speed control. Installing a 500-ohm 1/2 watt resistor across the 2 output terminals of the mA signal enables the use of the vdc signal. Set this configuration (VHPT, configuration mode under sub-mode OPT1) to 1 (4 to 20 mA or 2 to 10 vdc), 2 (0 to 20 mA or 0 to 10 vdc), or 3 (20 to 0 mA or 10 to 0 vdc) as desired depending on control type. For common output applications (single output for both circuits), the signal connections are made at terminal block TB2, terminals 14 and 15. For independent (one output for each circuit) applications, the signal connections are made at terminal block TB2, terminals 14 and 15 for circuit A, and terminals 12 and 13 for circuit B.

09DK AIR-COOLED CONDENSERS — The capacity of an air-cooled condenser increases with increased temperature difference (defined as saturated condensing temperature minus entering outdoor-air temperature) and decreases with decreased temperature difference. A drop in entering outdoor-air temperature results in a lower saturated condensing temperature. When outdoor-air temperature drops below the minimum temperature for standard units, additional head pressure control is required.

Table 6 — Field Configured Head Pressure Control Options

UNIT	CONFIGURATION OPTION	DESCRIPTION	POINT NAME	FACTORY CONFIGURATION
30HXC	Head Pressure Control Type	Method of controlling head pressure	HPCT	Water Cooled (30HXC Default, Do not modify)
	Variable Head Pressure Select	Method of controlling variable head pressure	VHPT	0=None 1 = 4 to 20 mA (*2 to 10 vdc) 2 = 0 to 20 mA (*0 to 10 vdc) 3 = 20 to 0 mA (*10 to 0 vdc)
30HXA	Head Pressure Control Type	Method of controlling head pressure	HPCT	No Control Air Cooled (30HXA Default) Common Condenser Independent Condenser
	Variable Head Pressure Select	Method of controlling variable head pressure	VHPT	0=None 1 = 4 to 20 mA (*2 to 10 vdc) 2 = 0 to 20 mA (*0 to 10 vdc) 3 = 20 to 0 mA (*10 to 0 vdc)

*A vdc signal can be generated by installing a 500-ohm 1/2-watt resistor across the 2 output terminals of the mA signal.

09DK044 Units — The 09DK044 units have accessory provision for fully automatic intermediate-season head pressure control through condenser fan cycling. Fan number 2 and 3 cycling is controlled by outdoor-air temperature through air temperature switches (ATS) 1 and 2.

The air temperature switches are located in the lower divider panel underneath the coil header. The sensing element is exposed to air entering the no. 1 fan compartment through a hole in the panel. Fan no. 1 is non-cycling.

The air temperature switch controls the fans as shown below:

09DK044 UNIT FAN	FAN SWITCH	TEMPERATURE
FAN 2	ON	Above 65 ± 3 F (18.3 ± 1.7 C)
		Between 55 and 65 F (12.8 and 18.3 C) and temperature falling
FAN 2	OFF	Below 55 ± 3 F (12.8 ± 1.7 C)
		Between 55 and 65 F (12.8 and 18.3 C) and temperature rising
FAN 3	ON	Above 80 ± 3 F (26.7 ± 1.7 C)
		Between 70 and 80 F (21.1 and 26.7 C) and temperature falling
	OFF	Below 70 ± 3 F (21.1 ± 1.7 C)
		Between 70 and 80 F (21.1 and 26.7 C) and temperature rising

09DK054-094 Units — The 09DK054-094 units have fully automatic intermediate season head pressure control through condenser fan cycling using electromechanical fan cycling controls. Standard head pressure controls regulate the 100 and 50/50% condenser capacity applications. Head pressure can also be controlled by fan cycling controls supplemented by the accessory Motormaster® V solid-state head pressure control. See Motormaster V installation instructions for more information.

The 09DK074-094 condensers are supplied with air temperature switches which are located in the control box with the sensing element exposed to ambient.

The 09DK054-094 condensers are supplied with fan cycling pressure switches suitable for use with R-22 refrigerant. Fan cycling pressure switches that are compatible with R-134a refrigerant pressures are shipped with the 30HXA chillers. These fan cycling pressure switches must be installed in place of the 09DK factory-installed switches before charging to ensure proper head pressure control.

UNIT	FAN	SWITCH	STATUS	ACTION
09DK 054, 064	OFM1 OFM2	None / MM		On with command or in response to MM
	OFM3 OFM4	FCPS	On	Above 185 ± 10 psig (1276 ± 69 kPa)
			Off	Between 97 and 185 psig (669 and 1276 kPa) and falling
	OFM3 OFM4	FCPS	Off	Below 97 ± 10 psig (669 ± 69 kPa)
On			Between 97 and 185 psig (669 and 1276 kPa) and rising	
09DK 074, 084, 094	OFM1 OFM2	None / MM		On with command or in response to MM
	OFM3 OFM4	FCPS	On	Above 185 ± 10 psig (1276 ± 69 kPa)
			Off	Between 97 and 185 psig (669 and 1276 kPa) and falling
	OFM3 OFM4	FCPS	Off	Below 97 ± 10 psig (669 ± 69 kPa)
			On	Between 97 and 185 psig (669 and 1276 kPa) and rising
	OFM5 OFM6	ATS	On	Above 80 ± 3 F (26.7 ± 1.7 C)
				Between 70 and 80 F (21.1 and 26.7 C) and temperature falling
			Off	Below 70 ± 3 F (21.1 ± 1.7 C)
Between 70 and 80 F (21.1 and 26.7 C) and temperature rising				

MM — Motormaster V Control

09DP AIR-COOLED CONDENSERS — The capacity of an air-cooled condenser increases with increased temperature difference (defined as saturated condensing temperature minus entering outdoor-air temperature) and decreases with decreased temperature difference. A drop in entering outdoor-air temperature results in a lower saturated condensing temperature. When outdoor-air temperature drops below the minimum temperature for standard units, additional head pressure control is required.

09DPM040-060 Units — The 09DPM040-060 units have fully automatic intermediate-season head pressure control through condenser fan cycling. Head pressure can also be controlled by fan cycling controls supplemented by the accessory Motormaster® V solid-state head pressure control. See Motormaster V installation instructions for more information.

The air temperature switch is located below the control panel. The sensing element is exposed to air entering the compartment through a hole in the panel.

Model 09DPM040-060 condensers are supplied with fan cycling pressure switches suitable for use with R-410A refrigerant. Fan cycling pressure switches that are compatible with R-134a refrigerant pressures are shipped with the 30HXA chillers. These fan cycling pressure switches must be installed in place of the 09DPM factory-provided switches before charging to ensure proper head pressure control.

UNIT	FAN	SWITCH	STATUS	ACTION
09DPM 040	OFM1	ATS	On	Above 70 ± 3 F (21.1 ± 1.7 C)
			Off	Between 60 and 70 F (15.6 and 21.1 C) and temperature falling
	OFM2	FCPS	On	Below 60 ± 3 F (15.6 ± 1.7 C)
			Off	Between 60 and 70 F (15.6 and 21.1 C) and temperature rising
	OFM2	FCPS	On	Above 185 ± 10 psig (1276 ± 69 kPa)
			Off	Between 97 and 185 psig (669 and 1276 kPa) and falling
OFM3	None / MM		Below 97 ± 10 psig (669 ± 69 kPa)	
09DPM 050-060	OFM1	ATS	On	Between 97 and 185 psig (669 and 1276 kPa) and rising
			Off	Above 70 ± 3 F (21.1 ± 1.7 C)
	OFM2 OFM4	FCPS	On	Between 60 and 70 F (15.6 and 21.1 C) and temperature falling
			Off	Below 60 ± 3 F (15.6 ± 1.7 C)
	OFM2 OFM4	FCPS	On	Between 60 and 70 F (15.6 and 21.1 C) and temperature rising
			Off	Above 185 ± 10 psig (1276 ± 69 kPa)
OFM3	None / MM		Between 97 and 185 psig (669 and 1276 kPa) and rising	
OFM3	None / MM		On with command or in response to MM	

MM — Motormaster V Control

09DPM065 Units — Model 09DPM065 units have fully automatic intermediate season head pressure control through condenser fan cycling using electromechanical fan cycling controls. Standard head pressure controls regulate the 100 and 50/50% condenser capacity applications. Head pressure can also be controlled by fan cycling controls supplemented by the accessory Motormaster® V solid-state head pressure control. See Motormaster V installation instructions for more information.

The air temperature switch is located in the control panel. The sensing element is exposed to the ambient through a hole in the control box.

UNIT	FAN	SWITCH	STATUS	ACTION
09DPM 065	OFM1 OFM3	None/ MM		On with command or in response to MM
	OFM2 OFM4	ATS	On	Above 70 ± 3 F (21.1 ± 1.7 C) Between 60 and 70 F (15.6 and 21.1 C) and temperature falling
			Off	Below 60 ± 3 F (15.6 ± 1.7 C) Between 60 and 70 F (15.6 and 21.1 C) and temperature rising

MM — Motormaster V Control

09DPM075-130 Units — The 09DPM075-130 units have fully automatic intermediate-season head pressure control through condenser fan cycling. Head pressure can also be controlled by fan cycling controls supplemented by the accessory Motormaster® V solid-state head pressure control. See Motormaster V installation instructions for more information.

The air temperature switch is located in the control panel. The sensing element is exposed to the ambient through a hole in the control box.

Model 09DPM075-130 condensers are supplied with fan cycling pressure switches suitable for use with R-410A refrigerant. Fan cycling pressure switches that are compatible with R-134a refrigerant pressures are shipped with the 30HXA chillers. These fan cycling pressure switches must be installed in place of the 09DPM factory-provided switches before charging to ensure proper head pressure control.

UNIT	FAN	SWITCH	STATUS	ACTION	
09DPM 075	OFM1 OFM5	None/ MM		On with command or in response to MM	
	OFM2 OFM6	ATS	On	Above 70 ± 3 F (21.1 ± 1.7 C) Between 60 and 70 F (15.6 and 21.1 C) and temperature falling	
			Off	Below 60 ± 3 F (15.6 ± 1.7 C) Between 60 and 70 F (15.6 and 21.1 C) and temperature rising	
	OFM3	FCPS/ MM	On	Above 185 ± 10 psig (1276 ± 69 kPa) or in response to MM Between 97 and 185 psig (669 and 1276 kPa) and falling or in response to MM	
			Off	Below 97 ± 10 psig (669 ± 69 kPa) or in response to MM Between 97 and 185 psig (669 and 1276 kPa) and rising or in response to MM	
	09DPM 085, 095	OFM1 OFM5	None/ MM		On with command or in response to MM
		OFM2 OFM6	ATS	On	Above 70 ± 3 F (21.1 ± 1.7 C) Between 60 and 70 F (15.6 and 21.1 C) and temperature falling
				Off	Below 60 ± 3 F (15.6 ± 1.7 C) Between 60 and 70 F (15.6 and 21.1 C) and temperature rising
OFM3		ATS/MM	On	Above 70 ± 3 F (21.1 ± 1.7 C) or in response to MM Between 60 and 70 F (15.6 and 21.1 C) and temperature falling or in response to MM	
			Off	Below 60 ± 3 F (15.6 ± 1.7 C) or in response to MM Between 60 and 70 F (15.6 and 21.1 C) and temperature rising or in response to MM	
OFM4		FCPS	On	Above 185 ± 10 psig (1276 ± 69 kPa) Between 97 and 185 psig (669 and 1276 kPa) and falling	
	Off		Below 97 ± 10 psig (669 ± 69 kPa) Between 97 and 185 psig (669 and 1276 kPa) and rising		

MM — Motormaster V Control

UNIT	FAN	SWITCH	STATUS	ACTION
09DPM 115	OFM1 OFM5	None/ MM		On with command or in response to MM
	OFM2	FCPS	On	Above 185 ± 10 psig (1276 ± 69 kPa) Between 97 and 185 psig (669 and 1276 kPa) and falling
			Off	Below 97 ± 10 psig (669 ± 69 kPa) Between 97 and 185 psig (669 and 1276 kPa) and rising
	OFM3 OFM7	FCPS/ MM	On	Above 185 ± 10 psig (1276 ± 69 kPa) and falling or in response to MM Between 97 and 185 psig (669 and 1276 kPa) and rising or in response to MM
			Off	Below 97 ± 10 psig (669 ± 69 kPa) or in response to MM Between 97 and 185 psig (669 and 1276 kPa) and rising or in response to MM
	OFM4 OFM8	ATS	On	Above 70 ± 3 F (21.1 ± 1.7 C) Between 60 and 70 F (15.6 and 21.1 C) and temperature falling
			Off	Below 60 ± 3 F (15.6 ± 1.7 C) Between 60 and 70 F (15.6 and 21.1 C) and temperature rising
	OFM1 OFM5	None/ MM		On with command or in response to MM
	OFM2 OFM6	FCPS	On	Above 185 ± 10 psig (1276 ± 69 kPa) Between 97 and 185 psig (669 and 1276 kPa) and falling
			Off	Below 97 ± 10 psig (669 ± 69 kPa) Between 97 and 185 psig (669 and 1276 kPa) and rising
	OFM3 OFM7	FCPS/ MM	On	Above 185 ± 10 psig (1276 ± 69 kPa) or in response to MM Between 97 and 185 psig (669 and 1276 kPa) and falling or in response to MM
			Off	Below 97 ± 10 psig (669 ± 69 kPa) or in response to MM Between 97 and 185 psig (669 and 1276 kPa) and rising or in response to MM
OFM4 OFM8	ATS	On	Above 70 ± 3 F (21.1 ± 1.7 C) Between 60 and 70 F (15.6 and 21.1 C) and temperature falling	
		Off	Below 60 ± 3 F (15.6 ± 1.7 C) Between 60 and 70 F (15.6 and 21.1 C) and temperature rising	

MM — Motormaster V Control

09AZ AIR-COOLED CONDENSERS — The 09AZV091-182 units are designed to operate specifically with 30HXA chillers, using R-134a refrigerant. Units with 8 fans have 2 direct controlled (applied to optional variable speed), 4 refrigerant pressure and 2 ambient temperature controlled fans. Units with 10 fans have 2 direct controlled (applied to optional variable speed), 4 refrigerant pressure and 4 ambient temperature controlled fans. Units with 12 fans have 2 direct controlled (applied to optional variable speed), 6 refrigerant pressure and 4 ambient temperature controlled fans. Field adjust 09AZ switch settings as follows:

PRESSURE	AMBIENT
Cut in 175 psi	Cut in 70 F
Cut out 145 psi	Cut out 60 F

OPERATION SEQUENCE — All condenser fans are allowed to operate once a call for cooling comes from the chiller. Direct fans will operate while refrigerant pressure and ambient temperature control fans maintain refrigerant head pressure based on existing refrigerant pressure and ambient temperature conditions. Optional variable speed control will ramp direct fan motor speed for improved low ambient performance.

VARIABLE SPEED FAN CONTROL — All units, when ordered with fan head pressure control are furnished with the number 1 condenser motor as a single-phase motor for use with head pressure control. The optional factory-mounted motor head pressure control contains a fan head pressure control device activated by a pressure sensor. The kit controls condenser-fan motor speed in response to the saturated condensing pressure.

ADJUSTING PID ROUTINES — The 30HXA and 30HXC head pressure control routines use PID (proportional integral derivative) loops to maintain a user-configurable head pressure set point. Gain defaults values are located in the SERV sub-mode under the Configuration mode (items H.PGN, H.IGN and H.DGN). The control calculates a new water valve position (30HXC) every 5 seconds based on these gain values and an error term equal to saturated condensing temperature minus head pressure set point. If the control routine is not responding fast enough to large changes (circuit starting, for example), increase the proportional term.

When the routine is making too great a change to valve position or fan speed, decrease the proportional term. To minimize hunting, keep the integral term positive and as low as possible. This value is used to control “droop,” which is common in master/submaster control schemes. The default for the derivative term is zero. The value should not need to be changed.

For more information on tuning PID loops, consult the Comfort Controller Installation manual, catalog number 808-890. Follow the instructions under Tuning Control loops.

Control Methods

SWITCH — Unit is started and stopped manually by switching the ENABLE/OFF/REMOTE CONTACT switch from OFF to ENABLE or by external contacts with the switch in the REMOTE position. The unit can be enabled and disabled by this action or all control methods.

7-DAY SCHEDULE — Unit is started and stopped in accordance with the schedule configured under Time Clock mode. This schedule can be configured from the Navigator™ module or from the CCN system.

OCCUPANCY — Unit is started and stopped in accordance with the local occupancy schedule accessible only from the CCN system. Schedule Number in Table SCHEDOVR must be configured to 1 to utilize the local occupancy schedule, or 65-99 to utilize a global schedule. If the Schedule Number is set to 0 the unit will operate in a continuous 24-hr Occupied mode.

CCN — Unit is started and stopped by communication over the CCN bus. The CHIL_S_S point in the A_UNIT table is provided for this purpose.

Table 7 illustrates how the control method and cooling setpoint select variables direct the operation of the chiller and the set point to which it controls. The illustration also shows the ON/OFF state of the machine for the given combinations.

Cooling Set Point Select

SINGLE — Unit operation is based on Cooling Setpoint 1 (CSP1).

DUAL SWITCH — Unit operation is based on Cooling Setpoint 1 (CSP.1) when the Dual Setpoint switch contacts are open and Cooling Setpoint 2 (CSP.2) when they are closed.

DUAL 7 DAY — Unit operation is based on Cooling Setpoint 1 (CSP.1) during the occupied mode and Cool Setpoint 2 (CSP.2) during the unoccupied mode as configured under Time Clock mode. Control method must be configured for Switch.

DUAL CCN OCCUPIED — Unit operation is based on Cooling Setpoint 1 (CSP.1) during the Occupied mode and

Cooling Setpoint 2 (CSP.2) during the Unoccupied mode as configured under the local occupancy schedule accessible only from the CCN system. Schedule Number in Table SCHEDOVR must be configured to 1. If the Schedule Number is set to 0 the unit will operate in a continuous 24-hr Occupied mode. Control method must be configured for Switch or CCN.

4 TO 20 mA INPUT — Unit operation is based on an external 4 to 20 mA signal input to the Energy Management Module (EMM).

Ice Mode — When Ice Mode is enabled Cooling Setpoint Select must be set to Dual Switch, Dual 7 day or Dual CCN Occupied and the Energy Management Module (EMM) must be installed. Unit operation is based on Cooling Setpoint 1 (CSP.1) during the Occupied mode, Ice Setpoint (CSP.3) during the Unoccupied mode with the Ice Done contacts open and Cooling Setpoint 2 (CSP.2) during the Unoccupied mode with the Ice Done contacts closed. These 3 set points can be utilized to develop your specific control strategy.

Cooler and Condenser (30HXC) Pump Control — The 30HX chillers can be configured for cooler and condenser (30HXC) pump control. Inputs for a cooler pump interlock and condenser flow switch or interlock are provided.

COOLER PUMP CONTROL (CPC, Configuration Mode/sub-mode OPT1) — Proper configuration of the cooler pump control is required to prevent possible cooler freeze-up. A cooler flow switch is factory installed to prevent operation without flow through the cooler. It is also recommended that the chiller be interlocked with the chiller water pump starter to provide additional protection. See page 67 of the Field Wiring section for proper connection of the cooler pump interlock.

The factory default setting for cooler pump control is “OFF.” It is recommended for all chillers that the cooler pump control be utilized unless the chilled water pump runs continuously or the chilled water system contains a suitable antifreeze solution. When the cooler pump control is “ON,” the cooler pump relay will be energized when the chiller enters an “ON” mode (i.e., ON LOCAL, ON TIME, ON CCN). The cooler pump relay will remain energized for 30 seconds after all compressors stop due to off command. In the event a freeze protection alarm is generated, the cooler pump relay will be energized whether cooler pump control is configured “ON” or “OFF.” The cooler pump relay is also energized anytime a compressor is started as well as when certain alarms are generated. The cooler pump relay should be used as an override to the external pump control if cooler pump control is not utilized.

IMPORTANT: If the cooler pump control relay output is not wired to control or override the operation of the chilled water pump an OFF DELAY of 10 minutes must be provided after the chiller is disabled to maintain cooler water flow during the pump down period.

30HXC brine applications below 32 F (0° C) leaving brine temperature require cooler pump control. To reduce the possibility of condenser freeze-up the cooler pump must be stopped or isolation valve closed in the event of loss of condenser water flow.

If cooler pump control is turned “OFF” or “ON” and the chilled water flow switch/interlock does not close within 5 minutes after the unit is enabled and in an “ON” mode, alarm A200 will be generated. If cooler pump control is turned “ON” and the chilled water flow switch/interlock is closed when the unit is enabled and enters an “ON” mode alarm A202 will be generated. Alarm A201 will be generated whenever the cooler pump interlock is open for at least 10 seconds during chiller operation.

Table 7 — Control Methods and Cooling Set Points

CONTROL TYPE (CTRL)	OCCUPANCY STATE	COOLING SET POINT SELECT (CLSP)				
		Single	Dual, Switch	Dual, 7 day	Dual, CCN Occ	4 to 20 mA†
Switch	Occupied	ON,CSP1	ON*	ON,CSP1	ON,CSP1	ON
	Unoccupied	ON,CSP1	ON*	ON,CSP2	ON,CSP2	ON
7 Day Occ	Occupied	ON,CSP1	ON*	Illegal	Illegal	ON
	Unoccupied	OFF	OFF	Illegal	Illegal	OFF
Occupancy	Occupied	ON,CSP1	ON*	Illegal	Illegal	ON
	Unoccupied	OFF	OFF	Illegal	Illegal	OFF
CCN	Occupied	ON,CSP1	ON*	ON,CSP1	ON,CSP1	ON
	Unoccupied	ON,CSP1	ON*	ON,CSP2	ON,CSP2	ON

*Dual set point switch input used. CSP1 used when switch input is open. CSP2 used when switch input is closed.
 †Cooling set point determined from 4 to 20 mA input to Energy Management Module (EMM) to terminals TB6-3,5.

CONDENSER PUMP CONTROL (CNPI AND CNPC, Configuration Mode/sub-mode OPT1) — Factory defaults for both condenser pump control and condenser flow switch are set to “NO CONTROL” and “OFF,” respectively. The condenser pump can be controlled in one of two ways: In the first method, (CNPC set to “ON WHEN OCCUPIED”) the pump can be controlled like the cooler pump. It is turned on whenever the machine is in an “ON” mode and turned off 30 seconds after all compressors stop and the machine is in an “OFF” mode. The second method (CNPC set to “ON WITH COMPRESSORS”), will energize the condenser pump output when the first compressor is started and deenergize the output 30 seconds after the last compressor stops.

When configured for a condenser flow switch/interlock (CNPI set to “ON”), an alarm A159 is generated if the input does not close within one minute after the machine enters an “ON” mode, or within one minute after the condenser pump relay is energized when configured “ON”. Alarm A159 is also generated if the flow switch/interlock opens for more than 10 seconds during chiller operation.

30HXC brine applications below 32 F (0° C) leaving brine temperature require condenser pump control to be configured to “ON WHEN OCCUPIED” and condenser pump interlock to be “ON.” A condenser water flow switch must be installed and wired to TB2 terminals 5 and 6. The condenser pump output remains energized for 30 minutes after the Enable/Off/Remote Contact switch is placed in the “OFF” position or the Remote Contacts are opened allowing refrigerant pressure equalization.

BRN.L (Configuration Mode, sub-mode SLCT) must be configured to YES if Brine FIOP is installed. This will energize liquid line solenoid valves on brine units when the condenser pump is “ON” and when the compressors are “OFF.” Liquid line solenoids are included as part of the Brine FIOP.

Flow Sensor — The factory-installed flow sensor/switch should not require adjustment.

Proper operation of this sensor/switch is necessary to allow the unit to operate and provide running freeze protection for the unit. When power is supplied to the switch, the green LED located in the cable connector will be illuminated.

When there is chilled water flow, but the flow is inadequate to close the switch and allow unit operation, one yellow LED will illuminate. One yellow LED can also indicate inoperative pump(s), closed valve, clogged strainer or air in the system.

When the two yellow LEDs are illuminated, the switch is closed and the unit will start and run. Various conditions can cause variations in flow and allow the switch to open and cause a “nuisance trip.” Greater constant flow will help reduce nuisance trips.

Measure the pressure drop across the cooler and use Appendix D to determine the cooler flow rate then determine if the flow rate is adequate for the application. Two yellow LEDs do not mean minimum flow requirements have been met.

Navigator™ Display Module Usage (See Fig. 8 and Tables 8-27) — The Navigator module provides a mobile user interface to the *ComfortLink™* control system. The display has up and down arrow keys, an **ESCAPE** key, and an **ENTER** key. These keys are used to navigate through the different levels of the display structure. See Table 8. Press the **ESCAPE** key until ‘Select a Menu Item’ is displayed to move through the top 11 mode levels indicated by LEDs on the left side of the display.





Fig. 8 — Navigator Module

Pressing the **ESCAPE** and **ENTER** keys simultaneously will put the Navigator into expanded text mode where full meaning of all sub-modes, items and their values can be displayed. Pressing the **ESCAPE** and **ENTER** keys when the display says ‘Select a Menu Item’ (Mode LED level) will return the Navigator to its default menu of rotating display items (those items in the VIEW sub-mode under the Run Status mode). In addition, the password will be disabled requiring that it be entered again before changes can be made to password protected items.

The Service Test function should be used to verify proper protected items. Press the **ESCAPE** key to exit out of the expanded text mode.



NOTE: When the LANG variable is changed, all appropriate display expansions will immediately change to the new language. No power-off or control reset is required when reconfiguring languages.

When a specific item is located, the item name appears on the left of the display, the value will appear near the middle of the display and the units (if any) will appear on the far right of



the display. Press the  key at a changeable item and the value will begin to flash. Items in the Configuration and Service Test modes are password protected. The password can be changed utilizing the Navigator or through CCN devices such as ComfortWORKS®, ComfortVIEW™ and Service Tool. The words ‘Enter Password’ will be displayed when required, with the default password also being displayed. Use the  and arrow keys to enter the 4 digits of the password. The default password is 1111. Use the following procedure to change the password:

1. Enter the correct password under PASS, *Service Password* (Configuration Mode, Sub-mode DISP).
2. Change P.A.S.E *Password Enable* (Configuration Mode, Sub-mode DISP) to DSBL.
3. Return to the PASS, *Service Password*, and change the password to the desired value. For example, 2222. Once changed, the screen will show the new value, 2222.
4. Return to the P.A.S.E *Password Enable*, and change the value to ENBL.

The password has been changed. If the password is required, the machine will show the default 1111 as the password. Use the up or down arrow keys to change the value to the correct password.

Changing item values or testing outputs is accomplished in the same manner. Locate and display the desired item. Press  so that the item value flashes. Use the arrow keys to change the value or state of a item and press the  key to accept it. Press the  key to return to the next higher level of structure. Repeat the process as required for other items. See Tables 9-27 for further details.

Two items, OAT *Outside Air Temperature* (Temperature Mode, Sub-mode UNIT) and SPT *Space Temperature* (Temperature Mode, Sub-mode UNIT) can be forced to a value at the Navigator. If one of these two points has been forced, a flashing ‘f’ will appear next to the value indicating a forced value. To remove the force, select the item and press the  key so that the value is flashing. Press the up and down arrow keys simultaneously and the force will be removed.

Service Test (See Table 10) — *Both main power and control circuit power must be on.* The Service Test function should be used to verify proper operation of the compressors, loaders, pumps, solenoids, fans, heaters, etc. To access the Service Test mode, the Enable/Off/Remote Contact switch must be in the Off position. Use the display keys to enter the Service Test mode and display ‘TEST OFF’. Press the  key and ‘Off’ will flash (Enter the password if required). Use either arrow key to change the ‘Off’ to ‘On’ and press . Switch the Enable/Off/Remote Contact switch to the Enable position. Use the arrow keys to select either sub-mode OUTS or COMP. Test the expansion valves, oil pumps, fans, cooler heaters, cooler/condenser pump relays, remote alarm relay, head pressure control, and compressor oil and motor cooling solenoids under the OUTS sub-mode. Measure 4 to 20 mA dc output using meter in series with violet or pink wire to controller. Refer to the Field Wiring section. These discrete outputs are then turned off if there is no keypad activity for 10 minutes. Test the compressors, loaders, minimum load valves and oil heaters under the COMP sub-mode. Compressor loaders, minimum load valve and oil heaters can be tested with compressors on or off. All compressor outputs can be turned on, but the control will limit the rate by staging one compressor per minute.

The relays under the COMP sub-mode will stay on for 10 minutes if there is no keypad activity. Compressors will stay on until they are turned off by the operator. The Service Test mode will remain enabled as long as there is more than one compressor turned on. All safeties are monitored during this test and will turn a compressor, circuit or motor off if necessary. Any other mode or sub-mode can be viewed or changed during the TEST mode. The STAT item (Run Status mode under sub-mode VIEW) will display ‘SERVICE TEST’ as long as the Service mode is enabled. The TEST sub-mode value must be changed back to OFF before the chiller can be switched to Enable or Remote contact for normal operation.

Configuring and Operating Dual Chiller Control (See Table 21A and 21B) — The dual chiller routine is available for the control of two units supplying chilled fluid on a common loop. This control is designed for either series or parallel fluid flow (PARA, Configuration mode under sub-mode RSET) arrangements. One chiller must be configured as the master chiller, the other as the slave chiller. For series fluid flow, the master chiller is installed so that it receives entering fluid from the slave chiller and its leaving fluid supplies the load. See Fig. 9. For parallel flow applications, an additional leaving water temperature thermistor (Dual Chiller LWT) must be installed as shown in Fig. 10 and 11 and connected to the master chiller. Refer to Thermistors section for sensor wiring.

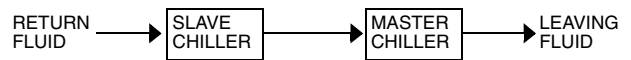
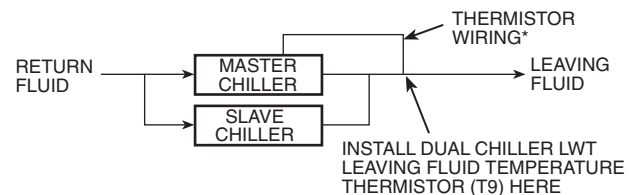

Fig. 9 — Dual Chiller Piping Arrangement (Series Fluid Flow)



- * Depending on piping sizes, use either:
- HH79NZ014 sensor/10HB50106801 well (3-in. sensor/well)
 - HH79NZ029 sensor/10HB50106802 well (4-in. sensor/well)

Fig. 10 — Dual Chiller Thermistor Location Parallel Fluid Flow

PART NUMBER	DIMENSIONS in. (mm)	
	A	B
10HB50106801	3.10 (78.7)	1.55 (39.4)
10HB50106802	4.10 (104.1)	1.28 (32.5)

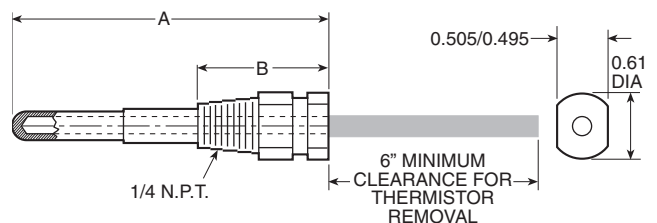

Fig. 11 — Dual Leaving Water Thermistor Well

To configure the two chillers for operation, follow the example shown in Tables 21A and 21B. The master chiller will be configured with a slave chiller at address 2. Also in this example, the master chiller will be configured to use Lead/Lag Balance to even out the chiller runtimes weekly. The Lag Start Delay feature will be set to 10 minutes. The chillers will be configured for parallel fluid flow. The master and slave chillers cannot have the same CCN address (CCNA, Configuration mode under OPT2). In addition, the chillers must be connected together on the same CCN bus. Connections can be made to the CCN screw terminals on TB3 in both chillers. The master chiller will determine which chiller will be Lead and which will be Lag. The master chiller controls the slave chiller by forcing the slave chiller ON and OFF, and forcing the control point of the slave chiller. The master chiller will also split demand limiting function appropriately between the two chillers, if demand limiting is enabled.

The master chiller is now configured for dual chiller operation. To configure the slave chiller, only the LLEN, PARA and MSSL variables need to be set. Enable the Lead/Lag chiller variable (LLEN) as shown in Tables 21A and 21B. Similarly, set the Master/Slave Select variable (MSSL) to SLVE. The parallel variable (PARA) must be configured the same as the master chiller. The slave chiller does not use the variables LLBL, LLBD and LLDY.

It is recommended to set the cooling set points to the same setting on both Master and Slave chillers for series flow (Duplex) applications. If outdoor air reset is required the outdoor air thermistor must be connected to the Slave chiller (TB5 term. 7 and 8). Outdoor Air Broadcast (BCST, OAT.B) must be configured "ON." Remote contacts should be connected to both Master and Slave to control unit operation. Optional control inputs and Energy Management Module (EMM) should be connected to the Master chiller.

Table 8 — Navigator Display Menu Structure

RUN STATUS	SERVICE TEST	TEMPERATURES	PRESSURES	SET POINTS	INPUTS	OUTPUTS	CONFIGURATION	TIME CLOCK	OPERATING MODES	ALARMS
Auto Display (VIEW)	Manual Mode On/Off (TEST)	Unit Temperatures (UNIT)	Ckt A Pressures (PRC.A)	Cooling (COOL)	Unit Discrete (GEN.I)	Unit Discrete (GEN.O)	Display (DISP)	Unit Time (TIME)	Modes (MODE)	Current (CRNT)
Machine Hours/Starts (RUN)	Ckt A/B Outputs (OUTS)	Ckt A Temperatures (CIR.A)	Ckt B Pressures (PRC.B)	Heating (HEAT)	Ckt A/B (CRCT)	Ckt A (CIR.A)	Machine (UNIT)	Unit Date (DATE)		Reset Alarms (RCRN)
Compressor Run Hours (HOUR)	Compressor Tests (COMP)	Ckt B Temperatures (CIR.B)		Head Pressure (HEAD)	Unit Analog (4-20)	Ckt B (CIR.B)	Options 1 (OPT1)	Daylight Savings Time (DST)		Alarm History (HIST)
Compressor Starts (STRT)							Options 2 (OPT2)	Schedule (SCHD)		
Software Version (VERS)							Temperature Reset (RSET)			
							Set Point Select (SLCT)			
							Service Configuration (SERV)			
							Broadcast Configuration (BCST)			

LEGEND

Ckt — Circuit

Table 9 — Configuration Mode and Sub-Mode Directory

SUB-MODE	KEYPAD ENTRY	ITEM	DISPLAY	ITEM EXPANSION	COMMENT
DISP		TEST	ON/OFF	TEST DISPLAY LEDs	See Backlight and Contrast adjustment in Tables 18 and 19.
		METR	ON/OFF	METRIC DISPLAY	Off = English On = Metric
		LANG	X	LANGUAGE SELECTION	Default: English English Espanol Francais Portuguese
		PAS.E	ENBL/DSBL	PASSWORD ENABLE	
		PASS	XXXX	SERVICE PASSWORD	Default: 1111
UNIT		TYPE	X	UNIT TYPE	Water Cooled (HXC) Split (HXA) Heat Machine Heat Reclaim
		TONS	XXX	UNIT SIZE	
		CAPA	XXX %	CIRCUIT A % CAPACITY	30HXA,C 076, 186 = 50 086, 126 = 54 096, 116, 136, 161 = 59 106, 246 = 63 146 = 55 171 = 45 206 = 57 261 = 65 271 = 67
		CMP.A	X	NUMBER CIRC A COMPRESSOR	HXA,C076-186 = 1 HXA,C206-271 = 2
		CMP.B	X	NUMBER CIRC B COMPRESSOR	HXA,C076-271 = 1
		TCPM	YES/NO	TCPMS INSTALLED?	Default: Yes
		DIS.S	XX.X °F	DISCHARGE SUPER SETPOINT	Default: 22° F DISCHARGE SUPERHEAT
		FAN.S	X	FAN STAGING SELECT	None (30HXA, 30HXC)
		CM.A1	XXX AMPS	COMPR. A1 MUST TRIP AMPS	Verify with Appendix A
		CR.A1	XXX AMPS	A1 MUST TRIP AMPS - READ	Verify with Appendix A. Read from CPMA1
		S1.A1	XXX	COMPR. A1 TCPM CONFIG SW1	Verify with Appendix A
		SR.A1	XXX	A1 TCPM CONFIG SW1 READ	Verify with Appendix A. Read from CPMA1
		CM.A2	XXX AMPS	COMPR. A2 MUST TRIP AMPS	Verify with Appendix A
		CR.A2	XXX AMPS	A2 MUST TRIP AMPS - READ	Verify with Appendix A. Read from CPMA2
		S1.A2	XXX	COMPR. A2 TCPM CONFIG SW1	Verify with Appendix A
		SR.A2	XXX	A2 TCPM CONFIG SW1 READ	Verify with Appendix A. Read from CPMA2
		CM.B1	XXX AMPS	COMPR. B1 MUST TRIP AMPS	Verify with Appendix A
		CR.B1	XXX AMPS	B1 MUST TRIP AMPS - READ	Verify with Appendix A. Read from CPMB1
		S1.B1	XXX	COMPR. B1 TCPM CONFIG SW1	Verify with Appendix A
		SR.B1	XXX	B1 TCPM CONFIG SW1 READ	Verify with Appendix A. Read from CPMB1
		CM.B2	XXX AMPS	COMPR. B2 MUST TRIP AMPS	Not applicable for 30HX
		CR.B2	XXX AMPS	B2 MUST TRIP AMPS - READ	Not applicable for 30HX
		S1.B2	XXX	COMPR. B2 TCPM CONFIG SW1	Not applicable for 30HX
	SR.B2	XXX	B2 TCPM CONFIG SW1 READ	Not applicable for 30HX	

Table 9 — Configuration Mode and Sub-Mode Directory (cont)























SUB-MODE	KEYPAD ENTRY	ITEM	DISPLAY	ITEM EXPANSION	COMMENT
OPT1		FLUD	X	COOLER FLUID	Default: Water Water Medium Temperature Brine Low Temperature Brine (30HX only)
		MLVS	YES/NO	MIN LOAD VALVE SELCT	Minimum Load Valve
		HPCT	X	HEAD PRESS CONTROL TYPE	No Control Air Cooled (30HXA default) Water Cooled (30HXC default) Common Cond (30HXA Common Condenser) Ind Cond (30HXA Independent Condenser)
		VHPT	X	VAR HEAD PRESSURE SELECT	None (30HX No Motormaster) 0-20 mA (0-10 vdc) 20-0 mA (10-0 vdc)
		PRTS	YES/NO	PRESSURE TRANSDUCERS	Default: Yes
		CPC	ON/OFF	COOLER PUMP CONTROL	Default: Off
		CNP.I	ON/OFF	CONDENSER PUMP INTERLOCK	Default: Off (Does not require condenser pump control)
		CNPC	X	CONDENSER PUMP CONTROL	Default: No Control No Control On with mode On with compressor(s)
		CWT.S	YES/NO	CONDENSER FLUID SENSORS	Default: No
		EMM	YES/NO	EMM MODULE INSTALLED	Default: No
OPT2		CTRL	X	CONTROL METHOD	Default: Switch Switch = Enable/Off/Remote Contact 7 Day Occ = 7 Day Schedule Occupancy = CCN Occupancy CCN = CCN Control
		LOAD	X	LOADING SEQUENCE SELECT	Default: Equal Equal Staged
		LLCS	X	LEAD/LAG SEQUENCE SELECT	Default: Automatic Automatic Circuit A Leads Circuit B Leads
		CP.SQ	X	COMPRESSOR SEQUENCE	Default: Automatic Automatic Compressor 1 Leads Compressor 2 Leads
		LCWT	XX.X ΔF	HIGH LCW ALERT LIMIT	Default: 60 Range: 2 to 60 F
		DELY	XX	MINUTES OFF TIME	Default: 0 Minutes Range: 0 to 15 Minutes
		CLS.C	ENBL/DSBL	CLOSE CONTROL SELECT	Default: Disable
		ICE.M	ENBL/DSBL	ICE MODE ENABLE	Default: Disable
		C.UNB	XX %	CURRENT UNBALANCE SETPOINT	Default: 15% Range: 10 to 30%
		NO.FL	ENBL/DSBL	ENABLE NO FLOW DETECTION	Default: Enable
		W.MSG	ENBL/DSBL	WINTERIZE ALERT CONFIG	Default: Enable
		ALR.C	X	ALARM RELAY USAGE	Default: Alerts + Alarms Alerts + Alarms Alarms Only Off

Table 9 — Configuration Mode and Sub-Mode Directory (cont)























SUB-MODE	KEYPAD ENTRY	ITEM	DISPLAY	ITEM EXPANSION	COMMENT
RSET		CRST	X	COOLING RESET TYPE	Default: No Reset No Reset 4 to 20 mA Input Outdoor Air Temperature Return Fluid Space Temperature
		CRT1	XXX.X °F	NO COOL RESET TEMP	Default: 125 F Range: 0° to 125 F For return fluid reset use cooler ΔT
		CRT2	XXX.X °F	FULL COOL RESET TEMP	Default: 0° F Range: 0° to 125 F For return fluid reset use cooler ΔT
		DGRC	XX.X ΔF	DEGREES COOL RESET	Default: 0° F Range: -30 to 30 F
		HRST	X	HEATING RESET TYPE	Default: No Reset No Reset 4 to 20 mA Input Outdoor Air Temperature Return Fluid Space Temperature
		HRT1	XXX.X °F	NO HEAT RESET TEMP	Default: 0° F Range: 0° to 125 F
		HRT2	XXX.X °F	FULL HEAT RESET TEMP	Default: 125 F Range: 0° to 125 F
		DGRH	XX.X ΔF	DEGREES HEAT RESET	Default: 0° F Range: -30 to 30 F
		DMDC	X	DEMAND LIMIT SELECT	Default: None None Switch 4 to 20 mA Input CCN Loadshed
		DM20	XXX %	DEMAND LIMIT AT 20 mA	Default: 100% Range: 0 to 100%
		SHNM	XXX	LOADSHED GROUP NUMBER	Default: 0 Range: 0 to 99
		SHDL	XXX %	LOADSHED DEMAND DELTA	Default: 0% Range: 0 to 60%
		SHTM	XXX	MAXIMUM LOADSHED TIME	Default: 60 Minutes Range: 0 to 120 Minutes
		DLS1	XXX %	DEMAND LIMIT SWITCH 1	Default: 80% Range: 0 to 100%
		DLS2	XXX %	DEMAND LIMIT SWITCH 2	Default: 50% Range: 0 to 100%
		LLEN	ENBL/DSBL	LEAD/LAG CHILLER ENABLE	Default: Disable
		MSSL	SLVE/MAST	MASTER/SLAVE SELECT	Default: Master
		SLVA	XXX	SLAVE ADDRESS	Default: 0 Range: 0 to 239
		LLBL	X	LEAD/LAG BALANCE SELECT	Default: Master Leads Master Leads Slave Leads Automatic
		LLBD	XXX	LEAD/LAG BALANCE DELTA	Default: 168 hours Range: 40 to 400 hours
		LLDY	XXX	LAG START DELAY	Default: 5 minutes Range: 0 to 30 minutes
		PARA	YES/NO	PARALLEL CONFIGURATION	Default: No (Series Flow)

Table 9 — Configuration Mode and Sub-Mode Directory (cont)

SUB MODE	KEYPAD ENTRY	ITEM	DISPLAY	ITEM EXPANSION	COMMENT
SLCT		CLSP	X	COOLING SETPOINT SELECT	Default: Single Single Dual Switch Dual 7 day Dual CCN Occupied 4 to 20 mA Input (requires EMM)
		HTSP	X	HEATING SETPOINT SELECT	Default: Single Single Dual Switch Dual 7 day Dual CCN Occupied 4 to 20 mA Input (requires EMM)
		RL.S	ENBL/DSBL	RAMP LOAD SELECT	Default: Disabled
		CRMP	X.X	COOLING RAMP LOADING	Default: 1.0 Range: 0.2 to 2.0
		HRMP	X.X	HEATING RAMP LOADING	Default: 1.0 Range: 0.2 to 2.0
		HCSW	COOL/HEAT	HEAT COOL SELECT	Default: Cool
		Z.GN	X.X	DEADBAND MULTIPLIER	Default: 2.0 Range: 1.0 to 4.0
		BRN.L	YES/NO	HXC BRINE CONFIG LOCK	Default: No Yes, if brine FIOP is installed (liquid line solenoid valves).
		FP.SP	XXX PSI	OIL FILTER DELTA P SETPT	Default: 35 PSI Range: 20 to 100 PSI
SERV		H.PGN	XX.X	HEAD PRESSURE P GAIN	Default: 1.0 Range: -20 to 20
		H.IGN	XX.X	HEAD PRESSURE I GAIN	Default: 0.1 Range: -20 to 20
		H.DGN	XX.X	HEAD PRESSURE D GAIN	Default: 0.0 Range: -20 to 20
		H.MIN	XXX.X	WATER VALVE MINIMUM POS.	Default: 20% Range: 0 to 100%
		MT.SP	XXX.X °F	MOTOR TEMP SETPOINT	Default: 200 F (170 F for Brine)
		BR.FZ	XXX.X °F	BRINE FREEZE POINT	Default: 34 F Range: -20 to 34 F
		MC.SP	XXX.X °F	MAX. COND. TEMP SETPOINT	Default: 145 F (HXA) 118 F (HXC) Range: 100 F To Default
		EX.S.A	XX.X %	EXVA START POSITION	Default: 20 % Range: 0 To 40 %
		EX.S.B	XX.X %	EXVB START POSITION	Default: 20 % Range: 0 To 40 %
		EN.A1	ENBL/DSBL	ENABLE COMPRESSOR A1	Default: Enable (All)
		EN.A2	ENBL/DSBL	ENABLE COMPRESSOR A2	Disable (HX076-186) Enable (HX206-271)
		EN.B1	ENBL/DSBL	ENABLE COMPRESSOR B1	Default: Enable (All)
		EN.B2	ENBL/DSBL	ENABLE COMPRESSOR B2	Disable (Not Applicable for 30HX)
		W.DNE	YES/NO	WINTERIZATION PERFORMED	
		ECON	YES/NO	ECONOMIZED	No (30HX076-146) Yes (30HX161-271)
		EVPS	X	NUMBER OF EVAP. PASSES	Range: 1 To 4
		LWTC	CIR A/CIR B	CIRCUIT WITH LWT SENSOR	Circuit closest to LWT sensor.
		AP.SP	XXX.X °F	APPROACH SETPOINT	Default: 3.0 F Range: 0.1 to 20.0 F
		CND.T	RTPF/MCHX	CND HX TYP	0 - RTPF, 1= MCHX
	CCN		CCNA	XXX	CCN ADDRESS
		CCNB	XXX	CCN BUS NUMBER	Default: 0 Range: 0 to 239
		BAUD	X	CCN BAUD RATE	Default: 9600 2400 4800 9600 19,200 38,400

Table 9 — Configuration Mode and Sub-Mode Directory (cont)

SUB-MODE	KEYPAD ENTRY	ITEM	DISPLAY	ITEM EXPANSION	COMMENT
BCST	ENTER	TD.B.C	ON/OFF	CCN TIME/DATE BROADCAST	Default: Off
	▼	OAT.B	ON/OFF	CCN OAT BROADCAST	Default: Off
	▼	GS.BC	ON/OFF	GLOBAL SCHEDULE BROADCAST	Default: Off
	▼	BC.AK	ON/OFF	BROADCAST ACKNOWLEDGER	Default: Off

Table 10 — Service Test Mode and Sub-Mode Directory

SUB-MODE	KEYPAD ENTRY	ITEM	DISPLAY	ITEM EXPANSION	COMMENT
TEST	ENTER		ON/OFF	SERVICE TEST MODE	To Enable Service Test Mode, move Enable/Off/Remote Contact switch to OFF. Change TEST to ON. Move switch to ENABLE.
OUTS	ENTER	EXV.A	XXX %	EXV % OPEN	
	▼	VH.PA	XXX %	VAR HEAD PRESS %	
	▼	OL.PA	ON/OFF	OIL PUMP	
	▼	MC.A1	ON/OFF	MOTOR COOLING SOLENOID A1	
	▼	MC.A2	ON/OFF	MOTOR COOLING SOLENOID A2	
	▼	OS.A1	ON/OFF	OIL SOLENOID A1	
	▼	OS.A2	ON/OFF	OIL SOLENOID A2	
	▼	EXV.B	XXX %	EXV % OPEN	
	▼	VH.PB	XXX %	VAR HEAD PRESS %	
	▼	OL.PB	ON/OFF	OIL PUMP	
	▼	MC.B1	ON/OFF	MOTOR COOLING SOLENOID B1	
	▼	MC.B2	ON/OFF	MOTOR COOLING SOLENOID B2	
	▼	OS.B1	ON/OFF	OIL SOLENOID B1	
	▼	OS.B2	ON/OFF	OIL SOLENOID B2	
	▼	FAN1	ON/OFF	FAN 1 RELAY	Circuit A condenser fans (30HXA only)
	▼	FAN2	ON/OFF	FAN 2 RELAY	Circuit B condenser fans (30HXA only)
	▼	FAN3	ON/OFF	FAN 3 RELAY	
	▼	FAN4	ON/OFF	FAN 4 RELAY	
	▼	CLR.P	ON/OFF	COOLER PUMP RELAY	
	▼	CLR.H	ON/OFF	COOLER HEATER	
▼	CND.P	ON/OFF	CONDENSER PUMP RELAY		
▼	RMT.A	ON/OFF	REMOTE ALARM RELAY		

Table 10 — Service Test Mode and Sub-Mode Directory (cont)

SUB-MODE	KEYPAD ENTRY	ITEM	DISPLAY	ITEM EXPANSION	COMMENT
COMP	ENTER	CC.A1	ON/OFF	COMPRESSOR A1 RELAY	
	▼	CC.A2	ON/OFF	COMPRESSOR A2 RELAY	
	▼	LD.A1	ON/OFF	LOADER A1 RELAY	
	▼	LD.A2	ON/OFF	LOADER A2 RELAY	
	▼	MLV	ON/OFF	MINIMUM LOAD VALVE	Energizes circuit A and B solenoids
	▼	OL.H.A	ON/OFF	OIL HEATER	
	▼	CC.B1	ON/OFF	COMPRESSOR B1 RELAY	
	▼	CC.B2	ON/OFF	COMPRESSOR B2 RELAY	
	▼	LD.B1	ON/OFF	LOADER B1 RELAY	
	▼	LD.B2	ON/OFF	LOADER B2 RELAY	
	▼	OL.H.B	ON/OFF	OIL HEATER	

Table 11 — Temperature Mode and Sub-Mode Directory

SUB-MODE	KEYPAD ENTRY	ITEM	DISPLAY	ITEM EXPANSION	COMMENT
UNIT	ENTER	CEWT	XXX.X °F	COOLER ENTERING FLUID	
	▼	CLWT	XXX.X °F	COOLER LEAVING FLUID	
	▼	OAT	XXX.X °F	OUTSIDE AIR TEMPERATURE	
	▼	SPT	XXX.X °F	SPACE TEMPERATURE	
	▼	CNDE	XXX.X °F	CONDENSER ENTERING FLUID	
	▼	CNDL	XXX.X °F	CONDENSER LEAVING FLUID	
	▼	DLWT	XXX.X °F	LEAD/LAG LEAVING FLUID	
CIR.A	ENTER	SCT.A	XXX.X °F	SATURATED CONDENSING TMP	
	▼	SST.A	XXX.X °F	SATURATED SUCTION TEMP	
	▼	SH.A	XXX.X ^F	DISCHARGE SUPERHEAT TEMP	
	▼	DGT.A	XXX.X °F	DISCHARGE GAS TEMP	Average of A1/A2 values for HX206-271
	▼	DGA.1	XXX.X °F	DISCHARGE GAS TEMP - A1	
	▼	DGA.2	XXX.X °F	DISCHARGE GAS TEMP - A2	HX206-271 only
	▼	MT.A1	XXX.X °F	A1 MOTOR TEMPERATURE	
	▼	MT.A2	XXX.X °F	A2 MOTOR TEMPERATURE	HX206-271 only
CIR.B	ENTER	SCT.B	XXX.X °F	SATURATED CONDENSING TMP	
	▼	SST.B	XXX.X °F	SATURATED SUCTION TEMP	
	▼	SH.B	XXX.X ^F	DISCHARGE SUPERHEAT TEMP	
	▼	DGT.B	XXX.X °F	DISCHARGE GAS TEMP	
	▼	DGB.1	XXX.X °F	DISCHARGE GAS TEMP - B1	
	▼	DGB.2	XXX.X °F	DISCHARGE GAS TEMP - B2	
	▼	MT.B1	XXX.X °F	B1 MOTOR TEMPERATURE	
	▼	MT.B2	XXX.X °F	B2 MOTOR TEMPERATURE	

Table 12 — Pressure Mode and Sub-Mode Directory

SUB-MODE	KEYPAD ENTRY	ITEM	DISPLAY	ITEM EXPANSION	COMMENT
PRC.A	ENTER	DP.A	XXX.X PSIG	DISCHARGE PRESSURE	
	▼	SP.A	XXX.X PSIG	SUCTION PRESSURE	
	▼	ECN.A	XXX.X PSIG	ECONOMIZER PRESSURE	
	▼	OP.A1	XXX.X PSIG	A1 OIL PRESSURE	
	▼	OP.A2	XXX.X PSIG	A2 OIL PRESSURE	
	▼	DO.A1	XXX.X PSI	A1 OIL PRESSURE DIFF.	Equals oil pressure minus Economizer pressure
	▼	DO.A2	XXX.X PSI	A2 OIL PRESSURE DIFF.	Equals oil pressure minus Economizer pressure
	▼	FD.A1	XXX.X PSI	A1 OIL FILTER DIFF. PRESS	Equals discharge pressure minus oil pressure
	▼	FD.A2	XXX.X PSI	A2 OIL FILTER DIFF. PRESS	Equals discharge pressure minus oil pressure
	▼	PS.A1	XX.X PSI	CALCULATED OIL PRESS A1	CKT A oil pressure setpoint 1 (See notes for Table 29)
	▼	PS.A2	XX.X PSI	CALCULATED OIL PRESS A2	CKT A oil pressure setpoint 2 (See notes for Table 29)
PRC.B	ENTER	DP.B	XXX.X PSIG	DISCHARGE PRESSURE	
	▼	SP.B	XXX.X PSIG	SUCTION PRESSURE	
	▼	ECN.B	XXX.X PSIG	ECONOMIZER PRESSURE	
	▼	OP.B1	XXX.X PSIG	B1 OIL PRESSURE	
	▼	OP.B2	XXX.X PSIG	B2 OIL PRESSURE	
	▼	DO.B1	XXX.X PSI	B1 OIL PRESSURE DIFF.	Equals oil pressure minus Economizer pressure
	▼	DO.B2	XXX.X PSI	B2 OIL PRESSURE DIFF.	Equals oil pressure minus Economizer pressure
	▼	FD.B1	XXX.X PSI	B1 OIL FILTER DIFF.	Equals discharge pressure minus oil pressure
	▼	FD.B2	XXX.X PSI	B2 OIL FILTER DIFF.	Equals discharge pressure minus oil pressure
	▼	PS.B1	XX.X PSI	CALCULATED OIL PRESS B1	CKT B oil pressure setpoint 1 (See notes for Table 29)
	▼	PS.B2	XX.X PSI	CALCULATED OIL PRESS B2	CKT B oil pressure setpoint 2 (See notes for Table 29)

Table 13 — Set Point Mode and Sub-Mode Directory

SUB-MODE	KEYPAD ENTRY	ITEM	DISPLAY	ITEM EXPANSION	COMMENT
COOL	ENTER	CSP.1	XXX.X °F	COOLING SETPOINT 1	Default: 44 F
	▼	CSP.2	XXX.X °F	COOLING SETPOINT 2	Default: 44 F
	▼	CSP.3	XXX.X °F	ICE SETPOINT	Default: 32 F
HEAT	ENTER	HSP.1	XXX.X °F	HEATING SETPOINT 1	Default: 100 F
	▼	HSP.2	XXX.X °F	HEATING SETPOINT 2	Default: 100 F
HEAD	ENTER	HD.P.A	XXX.X °F	HEAD PRESSURE SETPOINT A	Default: 113 F (30HXA) 85 F (30HXC)
	▼	HD.P.B	XXX.X °F	HEAD PRESSURE SETPOINT B	Default: 113 F (30HXA) 85 F (30HXC)

Table 14 — Inputs Mode and Sub-Mode Directory

SUB-MODE	KEYPAD ENTRY	ITEM	DISPLAY	ITEM EXPANSION	COMMENT
GEN.I	ENTER	STST	STRT/STOP	START/STOP SWITCH	
	▼	FLOW	ON/OFF	COOLER FLOW SWITCH	
	▼	CND.F	ON/OFF	CONDENSER FLOW SWITCH	
	▼	DLS1	ON/OFF	DEMAND LIMIT SWITCH 1	
	▼	DLS2	ON/OFF	DEMAND LIMIT SWITCH 2	
	▼	ICED	ON/OFF	ICE DONE	
	▼	DUAL	ON/OFF	DUAL SETPOINT SWITCH	
CRCT	ENTER	FKA1	ON/OFF	COMPRESSOR A1 FEEDBACK	
	▼	FKA2	ON/OFF	COMPRESSOR A2 FEEDBACK	
	▼	OIL.A	OPEN/CLSE	OIL LEVEL SWITCH	
	▼	A1.CR	XXX AMPS	COMP A1 RUNNING CURRENT	
	▼	A2.CR	XXX AMPS	COMP A2 RUNNING CURRENT	
	▼	FKB1	ON/OFF	COMPRESSOR B1 FEEDBACK	
	▼	FKB2	ON/OFF	COMPRESSOR B2 FEEDBACK	
	▼	OIL.B	OPEN/CLSE	OIL LEVEL SWITCH	
	▼	B1.CR	XXX AMPS	COMP B1 RUNNING CURRENT	
	▼	B2.CR	XXX AMPS	COMP B2 RUNNING CURRENT	
4-20	ENTER	DMND	XX.X MA	4-20 MA DEMAND SIGNAL	
	▼	RSET	XX.X MA	4-20 MA RESET SIGNAL	
	▼	CSP	XX.X MA	4-20 MA COOLING SETPOINT	
	▼	HSP	XX.X MA	4-20 MA HEATING SETPOINT	

Table 15 — Outputs Mode and Sub-Mode Directory

SUB-MODE	KEYPAD ENTRY	ITEM	DISPLAY	ITEM EXPANSION	COMMENT
GEN.O	ENTER	FAN1	ON/OFF	FAN 1 RELAY	
	▼	FAN2	ON/OFF	FAN 2 RELAY	
	▼	FAN3	ON/OFF	FAN 3 RELAY	
	▼	FAN4	ON/OFF	FAN 4 RELAY	
	▼	MLV	ON/OFF	MINIMUM LOAD VALVE	
	▼	C.PMP	ON/OFF	COOLER PUMP RELAY	
	▼	C.HT	ON/OFF	COOLER HEATER	
	▼	CNDP	ON/OFF	CONDENSER PUMP RELAY	
	▼	SMZ	X.X	LOAD/UNLOAD FACTOR	
CIR.A	ENTER	CC.A1	ON/OFF	COMPRESSOR A1 RELAY	
	▼	CC.A2	ON/OFF	COMPRESSOR A2 RELAY	
	▼	LD.A1	ON/OFF	LOADER A1 RELAY	
	▼	LD.A2	ON/OFF	LOADER A2 RELAY	
	▼	OL.PA	ON/OFF	OIL PUMP	
	▼	MC.A1	ON/OFF	MOTOR COOLING A1 SOLENOID	
	▼	MC.A2	ON/OFF	MOTOR COOLING A2 SOLENOID	
	▼	OL.H.A	ON/OFF	OIL HEATER	
	▼	OL.A1	ON/OFF	OIL SOLENOID A1	
	▼	OL.A2	ON/OFF	OIL SOLENOID A2	
	▼	EXV.A	XXX %	EXV % OPEN	
	▼	VH.PA	XXX %	VARIABLE HEAD PRESS %	
	CIR.B	ENTER	CC.B1	ON/OFF	COMPRESSOR B1 RELAY
▼		CC.B2	ON/OFF	COMPRESSOR B2 RELAY	
▼		LD.B1	ON/OFF	LOADER B1 RELAY	
▼		LD.B2	ON/OFF	LOADER B2 RELAY	
▼		OL.PB	ON/OFF	OIL PUMP	
▼		MC.B1	ON/OFF	MOTOR COOLING B1 SOLENOID	
▼		MC.B2	ON/OFF	MOTOR COOLING B2 SOLENOID	
▼		OL.H.B	ON/OFF	OIL HEATER	
▼		OL.B1	ON/OFF	OIL SOLENOID B1	
▼		OL.B2	ON/OFF	OIL SOLENOID B2	
▼		EXV.B	XXX %	EXV % OPEN	
▼		VH.PB	XXX %	VARIABLE HEAD PRESS %	

Table 16 — Operating Mode and Sub-Mode Directory

SUB-MODE	KEYPAD ENTRY	ITEM	DISPLAY	ITEM EXPANSION	COMMENT
MODE	ENTER	MD01	ON/OFF	CSM CONTROLLING CHILLER	
	▼	MD02	ON/OFF	WSM CONTROLLING CHILLER	
	▼	MD03	ON/OFF	MASTER/SLAVE CONTROL	
	▼	MD04	ON/OFF	LOW SOURCE PROTECTION	
	▼	MD05	ON/OFF	RAMP LOAD LIMITED	
	▼	MD06	ON/OFF	TIMED OVERRIDE IN EFFECT	
	▼	MD07	ON/OFF	LOW COOLER SUCTION TEMPA	
	▼	MD08	ON/OFF	LOW COOLER SUCTION TEMPB	
	▼	MD09	ON/OFF	SLOW CHANGE OVERRIDE	
	▼	MD10	ON/OFF	MINIMUM OFF TIME ACTIVE	
	▼	MD11	ON/OFF	LOW DISCHRG SUPERHEAT A	
	▼	MD12	ON/OFF	LOW DISCHRG SUPERHEAT B	
	▼	MD13	ON/OFF	DUAL SETPOINT	
	▼	MD14	ON/OFF	TEMPERATURE RESET	
	▼	MD15	ON/OFF	DEMAND LIMIT IN EFFECT	
	▼	MD16	ON/OFF	COOLER FREEZE PROTECTION	
	▼	MD17	ON/OFF	LOW TMP COOL/HI TMP HEAT	
	▼	MD18	ON/OFF	HI TMP COOL/LO TMP HEAT	
	▼	MD19	ON/OFF	MAKING ICE	
	▼	MD20	ON/OFF	STORING ICE	
	▼	MD21	ON/OFF	HIGH SCT CIRCUIT A	
	▼	MD22	ON/OFF	HIGH SCT CIRCUIT B	
	▼	MD23	ON/OFF	HIGH MOTOR CURRENT CIR. A	
	▼	MD24	ON/OFF	HIGH MOTOR CURRENT CIR. B	
	▼	MD25	ON/OFF	CKT A OFF REF FLOW DELAY*	
	▼	MD26	ON/OFF	CKT B OFF REF FLOW DELAY*	
	▼	MD27	ON/OFF	CIRCUIT A — PUMPING OUT	SHUTDOWN IN PROGRESS
	▼	MD28	ON/OFF	CIRCUIT B — PUMPOUT OUT	SHUTDOWN IN PROGRESS
	▼	MD29	ON/OFF	UNIT OFF: NO WATER FLOW	

*Recycle restart pending 15-minute delay due to loss of refrigerant flow detected at start-up.

Table 17 — Run Status Mode and Sub-Mode Directory

SUB-MODE	KEYPAD ENTRY	ITEM	DISPLAY	ITEM EXPANSION	COMMENT
VIEW	ENTER	EWT	XXX.X °F	ENTERING FLUID TEMP	
	▼	LWT	XXX.X °F	LEAVING FLUID TEMP	
	▼	SETP	XXX.X °F	ACTIVE SETPOINT	
	▼	CTPT	XXX.X °F	CONTROL POINT	
	▼	STAT	X	CONTROL MODE	SERVICE TEST OFF LOCAL OFF CCN OFF TIME OFF EMRGCY ON LOCAL ON CCN ON TIME
	▼	OCC	YES/NO	OCCUPIED	
	▼	MIN.L	XX MIN	MINUTES LEFT FOR START	
	▼	MODE	YES/NO	OVERRIDE MODES IN EFFECT	
	▼	CAP	XXX %	PERCENT TOTAL CAPACITY	
	▼	DEM.L	XXX %	ACTIVE DEMAND LIMIT	
	▼	ALRM	XXX	CURRENT ALARMS & ALERTS	
	▼	TIME	XX.XX	TIME OF DAY	00.00-23.59
	▼	MNTH	XX	MONTH OF YEAR	January, February, etc.
	▼	DATE	XX	DAY OF MONTH	01-31
RUN	ENTER	HRS.U	XXXX HRS	MACHINE OPERATING HOURS	
	▼	STR.U	XXXX	MACHINE STARTS	
HOUR	ENTER	HRS.A	XXXX HRS	CIRCUIT A RUN HOURS	
	▼	HRS.B	XXXX HRS	CIRCUIT B RUN HOURS	
	▼	HR.A1	XXXX HRS	COMPRESSOR A1 RUN HOURS	
	▼	HR.A2	XXXX HRS	COMPRESSOR A2 RUN HOURS	
	▼	HR.B1	XXXX HRS	COMPRESSOR B1 RUN HOURS	
	▼	HR.B2	XXXX HRS	COMPRESSOR B2 RUN HOURS	
STRT	ENTER	STR.A	XXXX	CIRCUIT A STARTS	
	▼	ST.A1	XXXX	COMPRESSOR A1 STARTS	
	▼	ST.A2	XXXX	COMPRESSOR A2 STARTS	
	▼	STR.B	XXXX	CIRCUIT B STARTS	
	▼	ST.B1	XXXX	COMPRESSOR B1 STARTS	
	▼	ST.B2	XXXX	COMPRESSOR B2 STARTS	

Table 17 — Run Status Mode and Sub-Mode Directory (cont)

SUB-MODE	KEYPAD ENTRY	ITEM	DISPLAY	ITEM EXPANSION	COMMENT
VERS		MBB		CESR-131344-xx-xx	xx-xx is Version number
		EXV		CESR-131172-xx-xx	xx-xx is Version number
		EMM		CESR-131174-xx-xx	xx-xx is Version number
		CP1		CESR131371-xx-xx	xx-xx is Version number
		CP2		CESR131371-xx-xx	xx-xx is Version number
		CP3		CESR131371-xx-xx	xx-xx is Version number
		AUX		CESR131333-xx-xx	xx-xx is Version number
		NAVI		CESR-131227-xx-xx	xx-xx is Version number

Table 18 — How to Adjust Navigator Backlight from Configuration Mode

SUB-MODE	KEYPAD ENTRY	ITEM	DISPLAY	ITEM EXPANSION	COMMENT
DISP		TEST	ON/OFF	TEST DISPLAY LEDS	
			Enter Password 1111		Enter password as required using ENTER key after each number.
		TEST	OFF		'OFF' will be flashing.
		TEST	ON		Change value to 'ON' ('ON' flashes).
		TEST	ON		Display Test is Enabled. The alarm and all mode LED's light up. The Navigator will display all block segments.
					Press arrow keys at the same time. The Navigator will display 'Adjust Brightness.'
					Use the up arrow key to brighten the backlight and the down arrow key to dim the backlight. Press the ESCAPE key when finished to exit the mode.

Table 19 — How to Adjust Navigator Contrast from Configuration Mode

SUB-MODE	KEYPAD ENTRY	ITEM	DISPLAY	ITEM EXPANSION	COMMENT
DISP		TEST	ON/OFF	TEST DISPLAY LEDS	
			Enter Password 1111		Enter password as required using ENTER key after each number.
		TEST	OFF		'OFF' will be flashing
		TEST	ON		Change value to 'ON' ('ON' flashes).
		TEST	ON		Display Test is Enabled. The alarm and all mode LED's light up. The Navigator will display all block segments.
					Press Enter and Escape keys at the same time. The Navigator will display 'ADJUST CONTRAST' with a percentage indication.
					Use the up arrow key to increase contrast and the down arrow key to decrease the contrast. Press the ESCAPE key when finished to exit the mode.

Table 20 — Time Clock Mode and Sub-Mode Directory

SUB-MODE	KEYPAD ENTRY	ITEM	DISPLAY	ITEM EXPANSION	COMMENT
TIME		HH.MM	XX.XX	HOUR AND MINUTE	Military (00:00 — 23:59)
DATE		MNTH	XX	MONTH OF YEAR	January, February, etc.
		DOM	XX	DAY OF MONTH	Range: 01-31
		DAY	X	DAY OF WEEK	Monday, Tuesday, etc.
		YEAR	XXXX	YEAR	
DST		STR.M	XX	MONTH	Default: 4 Range: 1-12
		STR.W	X	WEEK	Default: 1 Range: 1-5
		STR.D	X	DAY	Default: 7 Range: 1-7
		MIN.A	XX	MINUTES TO ADD	Default: 60 Range: 0-99
		STP.M	XX	MONTH	Default: 10 Range: 1-12
		STP.W	XX	WEEK	Default: 5 Range: 1-5
		STR.D	XX	DAY	Default: 7 Range: 1-7
		MIN.5	XX	MINUTES TO SUBTRACT	Default: 60 Range: 0-99
SCHD		MON.O	XX.XX	MONDAY OCCUPIED TIME	Default: 00.00 Range: 00.00 to 23.59
		MON.U	XX.XX	MONDAY UNOCCUPIED TIME	Default: 00.00 Range: 00.00 to 23.59
		TUE.O	XX.XX	TUESDAY OCCUPIED TIME	Default: 00.00 Range: 00.00 to 23.59
		TUE.U	XX.XX	TUESDAY UNOCCUPIED TIME	Default: 00.00 Range: 00.00 to 23.59
		WED.O	XX.XX	WEDNESDAY OCCUPIED TIME	Default: 00.00 Range: 00.00 to 23.59
		WED.U	XX.XX	WEDNESDAY UNOCCUPIED TIME	Default: 00.00 Range: 00.00 to 23.59
		THU.O	XX.XX	THURSDAY OCCUPIED TIME	Default: 00.00 Range: 00.00 to 23.59
		THU.U	XX.XX	THURSDAY UNOCCUPIED TIME	Default: 00.00 Range: 00.00 to 23.59
		FRI.O	XX.XX	FRIDAY OCCUPIED TIME	Default: 00.00 Range: 00.00 to 23.59
		FRI.U	XX.XX	FRIDAY UNOCCUPIED TIME	Default: 00.00 Range: 00.00 to 23.59
		SAT.O	XX.XX	SATURDAY OCCUPIED TIME	Default: 00.00 Range: 00.00 to 23.59
		SAT.U	XX.XX	SATURDAY UNOCCUPIED TIME	Default: 00.00 Range: 00.00 to 23.59
		SUN.O	XX.XX	SUNDAY OCCUPIED TIME	Default: 00.00 Range: 00.00 to 23.59
		SUN.U	XX.XX	SUNDAY UNOCCUPIED TIME	Default: 00.00 Range: 00.00 to 23.59

Table 21A — Example of Configuring Dual Chiller Control (Master Chiller)

SUB-MODE	ITEM	KEYPAD ENTRY	DISPLAY	ITEM EXPANSION	COMMENT
OPT2	OPT2	ENTER			
	CTRL	ENTER	SWITCH		VALUE FLASHES
	CTRL	ENTER	SWITCH	CONTROL METHOD	SEE NOTE 1
		▼			
	CCNA	ENTER	1		DEFAULT 1
	CCNA	ENTER	1	CCN ADDRESS	CHANGE IF REQUIRED
		▼			
	CCNB	ENTER	0		DEFAULT 0
	CCNB	ENTER	0	CCN BUS NUMBER	CHANGE IF REQUIRED
	CCNB	ESCAPE	OPT2		
		▼	RESET		PROCEED TO SUBMODE RSET
RSET	RSET	ENTER			
	CRST		NO RESET	COOLING RESET TYPE	
		▼			▼ 15 ITEMS
	LLEN	ENTER	DSBL	LEAD/LAG CHILLER ENABLE	SCROLLING STOPS
		ENTER	DSBL		VALUE FLASHES
		▲	ENBL		SELECT ENBL
	LLEN	ENTER	ENBL	LEAD/LAG CHILLER ENABLE	CHANGE ACCEPTED
		▼	MSSL		
	MSSL	ENTER	MAST	MASTER/SLAVE SELECT	DEFAULT MAST
		▼	SLVA	SLAVE ADDRESS	
	SLVA	ENTER	0		VALUE FLASHES
		▲	2		SELECT 2
	SLVA	ENTER	2	SLAVE ADDRESS	CHANGE ACCEPTED
		▼			
	LLBL	ENTER	MASTER LEADS	LEAD/LAG BALANCE SELECT	VALUE FLASHES
		▲	AUTOMATIC		SELECT AUTOMATIC
	LLBL	ENTER	AUTOMATIC	LEAD/LAG BALANCE SELECT	CHANGE ACCEPTED
		▼			
	LLBD	ENTER	168	LEAD/LAG BALANCE DELTA	DEFAULT 168
		ENTER			
		▼			
	LLDY	ENTER	5	LAG START DELAY	
		ENTER	5		VALUE FLASHES
		▲	10		SELECT 10
	LLDY	ENTER	10	LAG START DELAY	CHANGE ACCEPTED
	PARA	ENTER	NO	PARALLEL CONFIGURATION	DEFAULT NO
		▲	YES		SELECT YES
	PARA	ENTER	YES	PARALLEL CONFIGURATION	SEE NOTE 2
		ESCAPE	RSET		MASTER COMPLETE

NOTES:

1. The desired control method should be configured for the Master only. The slave is always configured for switch control.
2. Yes = Parallel piping configuration. No = Series piping configuration. Master and Slave chillers must both be configured for the same piping configuration.

Table 21B — Example of Configuring Dual Chiller Control (Slave Chiller)

SUB-MODE	ITEM	KEYPAD ENTRY	DISPLAY	ITEM EXPANSION	COMMENT
OPT2	OPT2	<input type="button" value="ENTER"/>			
	CTRL	<input type="button" value="ENTER"/>	SWITCH	CONTROL METHOD	SEE NOTE 1
		<input type="button" value="ESCAPE"/>	SWITCH		
		<input type="button" value="ESCAPE"/>	CTRL		
	CTRL	<input type="button" value="▼"/>	CCNA		
	CCNA	<input type="button" value="ENTER"/>	1	CCN ADDRESS	SCROLLING STOPS
		<input type="button" value="ENTER"/>	1		VALUE FLASHES
		<input type="button" value="▲"/>	2		SELECT 2 (SEE NOTE 2)
	CCNA	<input type="button" value="ENTER"/>	2	CCN ADDRESS	CHANGE ACCEPTED
		<input type="button" value="ESCAPE"/>	CCNA		
		<input type="button" value="▼"/>	CCNB		
	CCNB	<input type="button" value="ENTER"/>	0	CCN BUS NUMBER	DEFAULT 0 (SEE NOTE 3)
		<input type="button" value="ESCAPE"/>	CCNB		
		<input type="button" value="ESCAPE"/>	OPT2		
		<input type="button" value="▼"/>	RSET		PROCEED TO SUBMODE RSET
RSET	RSET	<input type="button" value="ENTER"/>	CRST	COOLING RESET TYPE	
		<input type="button" value="▼"/>	LLEN	LEAD/LAG CHILLER ENABLE	<input type="button" value="▼"/> 15 ITEMS
	LLEN	<input type="button" value="ENTER"/>	DSBL		SCROLLING STOPS
		<input type="button" value="ENTER"/>	DSBL		VALUE FLASHES
		<input type="button" value="▲"/>	ENBL		SELECT ENBL
	LLEN	<input type="button" value="ENTER"/>	ENBL	LEAD/LAG CHILLER ENABLE	CHANGE ACCEPTED
		<input type="button" value="ESCAPE"/>	LLEN		
		<input type="button" value="▼"/>	MSSL	MASTER/SLAVE SELECT	
	MSSL	<input type="button" value="ENTER"/>	MAST		SCROLLING STOPS
		<input type="button" value="ENTER"/>	MAST		VALUE FLASHES
		<input type="button" value="▲"/>	SLVE		SELECT SLAVE
	MSSL	<input type="button" value="ENTER"/>	SLVE	MASTER/SLAVE SELECT	CHANGE ACCEPTED
		<input type="button" value="ESCAPE"/>	MSSL		
		<input type="button" value="▼"/>			<input type="button" value="▼"/> 5 ITEMS
	PARA	<input type="button" value="ENTER"/>	NO	PARALLEL CONFIGURATION	
		<input type="button" value="▲"/>	YES		SELECT YES
	PARA	<input type="button" value="ENTER"/>	YES	PARALLEL CONFIGURATION	SEE NOTE 5
		<input type="button" value="ESCAPE"/>	RSET		SLAVE COMPLETE

NOTES:

1. Slave is always configured for switch control.
2. Slave CCN Address must be different than Master.
3. Slave CCN Bus Number must be the same as Master.
4. Slave does not require LLBL, LLBD or LLDY to be configured.
5. Yes = Parallel piping configuration. No = Series piping configuration.
Master and Slave chillers must both be configured for the same piping configuration.

Alarms/Alerts — Alarms and alerts are messages that one or more faults have been detected. The alarms and alerts indicate failures that cause the unit to shut down, terminate an option (such as reset) or result in the use of a default value such as a set point. Refer to the Troubleshooting section for more information.

Up to 25 alarms/alerts can be displayed in currently active alarms. Up to 50 alarms/alerts can be stored in the alarm history. See Tables 22 and 23 to view and clear alarms.

IMPORTANT: Do not clear the alarms without first reviewing the full list and investigating and correcting the cause of the alarms.

When an alarm or alert is stored in the display and the machine automatically resets, the alarm/alert is deleted. Codes for safeties which do not automatically reset are not deleted until the problem is corrected and the machine is reset. Follow the example in Table 23 to clear the alarm from the Main Base Board (MBB) history.

Alarm relay usage alerts and alarms are configurable in (CONFIGURATION MODE, SUB-MODE OPT2) to be both one or the other or off paragraph.

Run Hours and Starts — The HOUR and STRT sub-modes under the Run Status mode contain items for number of hours for each circuit and each compressor and the total number of starts for each compressor. All items are password protected, but can be changed if a replacement MBB is installed.

Press to make the current value flash. Use the arrow keys to configure the correct value and press the key again. Record the current values from the MBB before removing the module or downloading new software.

Temperature Reset — The control system is capable of handling leaving-fluid temperature reset based on return cooler fluid temperature. Because the change in temperature through the cooler is a measure of the building load, the return temperature reset is in effect an average building load reset method. The control system is also capable of temperature reset based on outdoor-air temperature (OAT), space temperature (SPT), or from an externally powered 4 to 20 mA signal. Accessory sensors must be used for OAT and SPT reset (HH79NZ023 for OAT and HH51BX006 for SPT). The Energy Management Module (EMM) must be used for temperature reset using a 4 to 20 mA signal.

To use the return reset, four variables must be configured. In the Configuration mode under the sub-mode RSET, items CRST, CRT1, CRT2, and DGRC must be set properly. See Tables 24 and 25 on page 35 for correct configuration.

To reset the return fluid temperature, the unit set point is reset from full load based on the chilled fluid return temperature. The example uses a reset value of 10 degrees at full reset. Full reset is at a 2-degree temperature difference across the cooler and no reset would be at a 10 F difference across the cooler. See Fig. 12-15 and Table 25.

Under normal operation, the chiller will maintain a constant leaving fluid temperature approximately equal to the chilled fluid set point. As the cooler load varies, the entering cooler fluid will change in proportion to the load as shown in Fig. 12. Usually the chiller size and leaving-fluid temperature set point are selected based on a full-load condition. At part load, the fluid temperature set point may be colder than required. If the leaving fluid temperature was allowed to increase at part load, the efficiency of the machine would increase.

Return temperature reset allows for the leaving temperature set point to be reset upward as a function of the return fluid temperature or, in effect, the building load.

Figure 12 is an example of no reset. Figures 13, 14, and 15 are examples of outdoor air, space and return water temperature resets.

Table 22 — Alarms Mode and Sub-Mode Directory

SUB-MODE	KEYPAD ENTRY	ITEM	ITEM EXPANSION	COMMENT
CRNT	<input type="button" value="ENTER"/>	Axxx or Txxx	CURRENTLY ACTIVE ALARMS	Alarms are shown as Axxx. Alerts are shown as Txxx.
RCRN	<input type="button" value="ENTER"/>	YES/NO	RESET ALL CURRENT ALARMS	
HIST	<input type="button" value="ENTER"/>	Axxx or Txxx	ALARM HISTORY	Alarms are shown as Axxx. Alerts are shown as Txxx.

Table 23 — Example of Reading and Clearing Alarms

SUB-MODE	KEYPAD ENTRY	ITEM	ITEM EXPANSION	COMMENT
CRNT	<input type="button" value="ENTER"/>	Axxx or Txxx	CURRENTLY ACTIVE ALARMS	ACTIVE ALARMS (Axxx) OR ALERTS (Txxx) DISPLAYED.*
CRNT	<input type="button" value="ESCAPE"/>			
RCRN	<input type="button" value="▼"/>	NO		Use to clear active alarms/alerts
	<input type="button" value="ENTER"/>	NO		NO Flashes
	<input type="button" value="▲"/>	YES		Select YES
	<input type="button" value="ENTER"/>	NO		Alarms/alerts clear, YES changes to NO

*Press and simultaneously to display expanded alarm description.

Table 24 — Configuring Temperature Reset

MODE	KEYPAD ENTRY	SUB-MODE	KEYPAD ENTRY	ITEM	DISPLAY	ITEM EXPANSION	COMMENT
CONFIGURATION	ENTER	DISP	ENTER	TEST	ON/OFF	TEST DISPLAY LEDs	
	▼	UNIT	ENTER	TYPE	X	UNIT TYPE	
	▼	OPT1	ENTER	FLUD	X	COOLER FLUID	
	▼	OPT2	ENTER	CTRL	X	CONTROL METHOD	
	▼	RSET	ENTER	CRST	X	COOLING RESET TYPE	0 = No Reset 1 = 4 to 20 mA Input (EMM required) (Connect to EMM J6-2,5) 2 = Outdoor-Air Temperature (Connect to TB5-7,8) 3 = Return Fluid 4 = Space Temperature (Connect to TB5-5,6)
			▼	CRT1	XXX.X F	NO COOL RESET TEMP	Default: 125 F (51.7 C) Range: 0° to 125 F Set to 4.0 for CRST= 1 No Cool Reset ΔT for CRST=3
			▼	CRT2	XXX.X F	FULL COOL RESET TEMP	Default: 0° F (-17.8 C) Range: 0° to 125 F Set to 20.0 for CRST=1 Full Cool Reset ΔT for CRST=3
			▼	DGRC	XX.X ΔF	DEGREES COOL RESET	Default: 0° F (0° C) Range: -30 to 30 F (-16.7 to 16.7 C)

Table 25 — Return Water Reset

SUB-MODE	KEYPAD ENTRY	ITEM	DISPLAY	ITEM EXPANSION	COMMENT
RSET	ENTER	CRST	3	COOLING RESET TYPE	0 = no reset 1 = 4 to 20 mA input 2 = Outdoor air temp 3 = Return Fluid 4 = Space Temperature
	▼	CRT1	10.0 F (5.5 C)	NO COOL RESET TEMP	Default: 125 F (51.7 C) Range: 0° to 125 F
	▼	CRT2	2.0 F (1.1 C)	FULL COOL RESET TEMP	Default: 0° F (-17.8 C) Range: 0° to 125 F
	▼	DGRC	5.0 ΔF (2.8 ΔC)	DEGREES COOL RESET	Default: 0° F (0° C) Range: -30 to 30 F (-16.7 to 16.7 C)

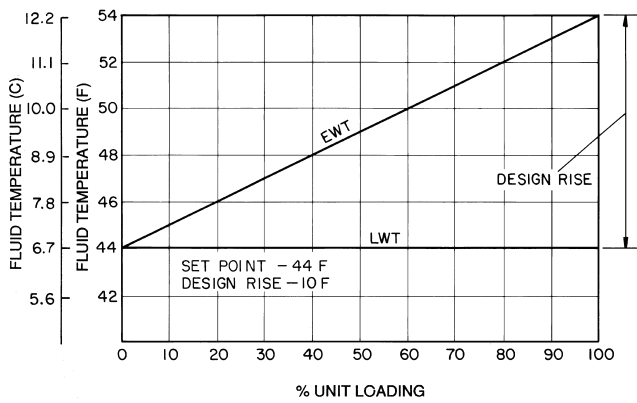

LEGEND
EWT — Entering Water (Fluid) Temperature
LWT — Leaving Water (Fluid) Temperature

Fig. 12 — Cooling Return Water — No Reset

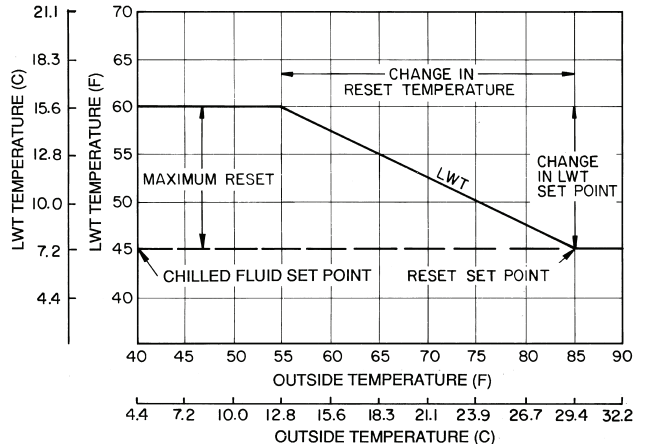

LEGEND
LWT — Leaving Water (Fluid) Temperature

Fig. 13 — Outdoor-Air Temperature Reset

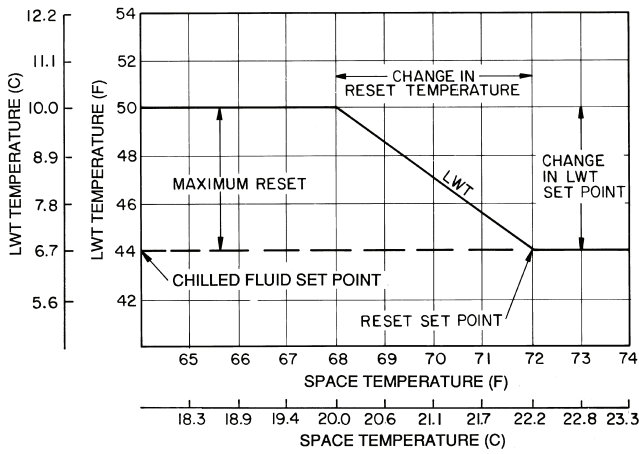

LEGEND

LWT — Leaving Water (Fluid) Temperature

Fig. 14 — Space Temperature Reset

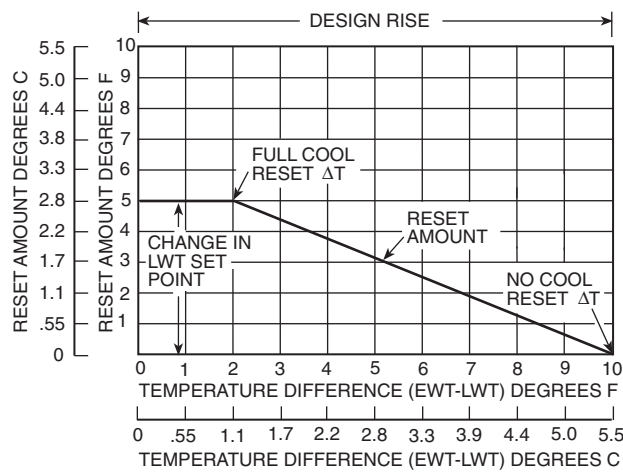

LEGEND

EWT — Entering Water (Fluid) Temperature
LWT — Leaving Water (Fluid) Temperature

Fig. 15 — Return Water Reset

Demand Limit — Demand Limit is a feature that allows the unit capacity to be limited during periods of peak energy usage. See Fig. 16. There are 3 types of demand limiting that can

be configured. The first type is through 2-stage switch control, which will reduce the maximum capacity to 2 user-configurable percentages. The second type is by 4 to 20 mA signal input which will reduce the maximum capacity linearly between 100% at a 4 mA input signal (no reduction) down to the user-configurable level at a 20 mA input signal. The third type uses the CCN Loadshed module and has the ability to limit the current operating capacity to maximum and further reduce the capacity if required.

NOTE: The 2-stage switch control and 4- to 20-mA input signal types of demand limiting require the Energy Management Module (EMM).

To use Demand Limit, select the type of demand limiting to use. Then configure the Demand Limit set points based on the type selected.

DEMAND LIMIT (2-Stage Switch Controlled) — To configure Demand Limit for 2-stage switch control set the Demand Limit Select (DMDC) to 1. Then configure the 2 Demand Limit Switch points (DLS1 and DLS2) to the desired capacity limit. See Table 26. Capacity steps are controlled by 2 relay switch inputs field wired to TB6.

For Demand Limit by 2-stage switch control, closing the first stage demand limit contact will put the unit on the first demand limit level. The unit will not exceed the percentage of capacity entered as Demand Limit Switch 1 set point. Closing contacts on the second demand limit switch prevents the unit from exceeding the capacity entered as Demand Limit Switch 2 set point. The demand limit stage that is set to the lowest demand takes priority if both demand limit inputs are closed. If the demand limit percentage does not match unit staging, the unit will limit capacity to the closest capacity stage.

To disable demand limit configure the DMDC to 0. See Table 26.

EXTERNALLY POWERED DEMAND LIMIT (4 to 20 mA Controlled) — To configure Demand Limit for 4 to 20 mA control set the Demand Limit Select (DMDC) to 2. Then configure the Demand Limit at 20 mA (DM20) to the maximum loadshed value desired. The control will reduce allowable capacity to this level for the 20 mA signal.

DEMAND LIMIT (CCN Loadshed Controlled) — To configure Demand Limit for CCN Loadshed control set the Demand Limit Select (DMDC) to 3. Then configure the Loadshed Group Number (SHNM), Loadshed Demand Delta (SHDL), and Maximum Loadshed Time (SHTM). See Table 26.

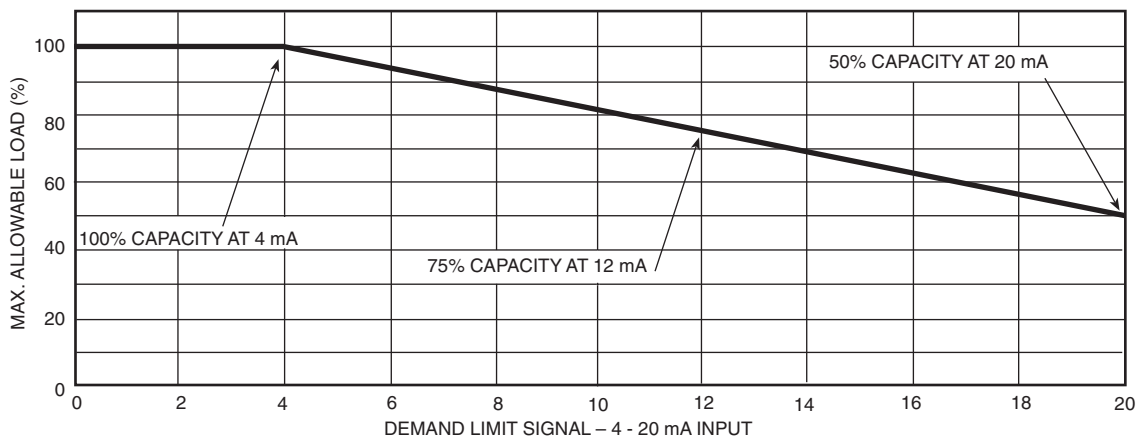
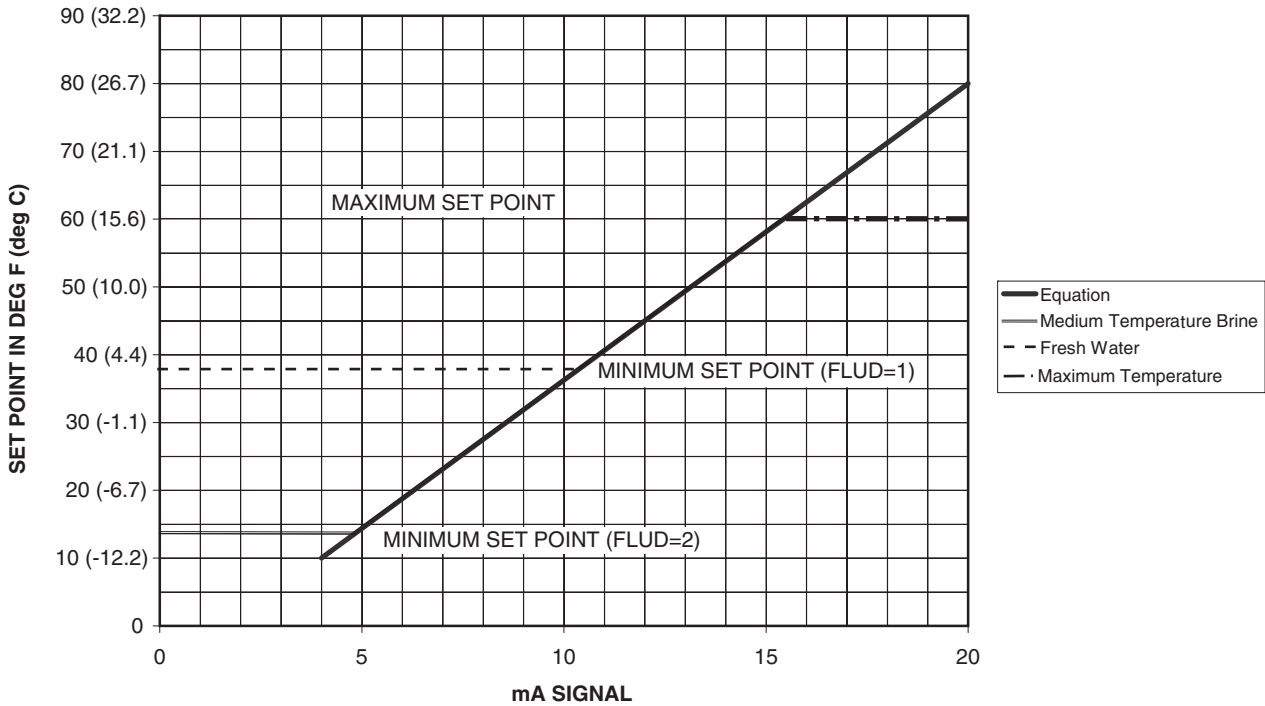

Fig. 16 — 4 to 20 mA Demand Limiting

The Loadshed Group number is established by the CCN system designer. The *ComfortLink*™ controls will respond to a Redline command from the Loadshed module. When the Redline command is received, the current stage of capacity is set to the maximum capacity available. Should the loadshed module send a Loadshed command, the *ComfortLink* controls will reduce the current stages by the value entered for Loadshed Demand delta. The Maximum Loadshed Time defines the maximum length of time that a loadshed condition is allowed to exist. The *ComfortLink* controls will disable the Redline/

Loadshed command if no Cancel command has been received within the configured maximum loadshed time limit.

Cooling Set Point (4 to 20 mA) — Unit operation is based on an external 4 to 20 mA signal input to the Energy Management Module (EMM). The signal is connected to TB6-3,5 (+,-). Figure 17 shows how the 4 to 20 mA signal is linearly calculated on an overall 10 F to 80 F for both Water and Medium Temperature Brine COOLER FLUID configurations. See Table 27 for configuration instructions.



LEGEND

EMM — Energy Management Module

Fig. 17 — Cooling Set Point (4 to 20 mA)

Table 26 — Configuring Demand Limit

MODE	KEYPAD ENTRY	SUB-MODE	KEYPAD ENTRY	ITEM	DISPLAY	ITEM EXPANSION	COMMENT
CONFIGURATION	ENTER	DISP	ENTER	TEST	ON/OFF	Test Display LEDs	
	▼	UNIT	ENTER	TYPE	X	Unit Type	
	▼	OPT1	ENTER	FLUD	X	Cooler Fluid	
	▼	OPT2	ENTER	CTRL	X	Control Method	
	▼	RSET	ENTER	CRST	X	Cooling Reset Type	
			▼	CRT1	XXX.X °F	No Cool Reset Temperature	
			▼	CRT2	XXX.X °F	Full Cool Reset Temperature	
			▼	DGRC	XX.X ΔF	Degrees Cool Reset	
			▼	DMDC	X	Demand Limit Select	Default: 0 0 = None 1 = Switch 2 = 4 to 20 mA Input 3 = CCN Loadshed
			▼	DM20	XXX%	Demand Limit at 20 mA	Default: 100% Range: 0 to 100
			▼	SHNM	XXX	Loadshed Group Number	Default: 0 Range: 0 to 99
			▼	SHDL	XXX%	Loadshed Demand Delta	Default: 0% Range: 0 to 60%
			▼	SHTM	XXX MIN	Maximum Loadshed Time	Default: 60 min. Range: 0 to 120 min.
			▼	DLS1	XXX %	Demand Limit Switch 1	Default: 80% Range: 0 to 100%
		▼	DLS2	XXX%	Demand Limit Switch 2	Default: 50% Range: 0 to 100%	

NOTE: Heating reset values skipped in this example.

Table 27 — Menu Configuration of 4 to 20 mA Cooling Set Point Control

MODE (RED LED)	KEYPAD ENTRY	SUB-MODE	KEYPAD ENTRY	ITEM	DISPLAY	ITEM EXPANSION	COMMENT
CONFIGURATION	ENTER	DISP					
	▼	UNIT					
	▼	OPT1					
	▼	OPT2					
	▼	RSET					
	▼	SLCT	ENTER	CLSP	0	COOLING SETPOINT SELECT	
			ENTER		0		Scrolling Stops
			ENTER		0		Flashing '0'
			▲		4		Select '4'
			ENTER		4		Change Accepted

TROUBLESHOOTING

The 30HX screw chiller control has many features to aid in troubleshooting. By using the Navigator control, operating conditions of the chiller can be viewed while the chiller is running. The Service Test function allows for testing of all outputs and compressors. Verify that the chiller is properly configured, including options and/or accessories, using the Configuration mode. For checking specific items, refer to the Mode/Sub-Mode directory (Table 8).

Checking Display Codes — To determine how the machine has been programmed to operate, check the diagnostic information displayed in the Status function and the configuration information displayed in the Service function.

Unit Shutoff — To shut the unit off, move the Enable/Off/Remote Contact switch to the Off position. Both circuits will complete a pumpdown cycle and all compressors and solenoids will shut off. For extreme cases, move the Emergency On/Off switch to the Off position. All compressors, solenoids and other outputs will stop immediately.

Complete Unit Stoppage — Complete unit stoppage can be caused by any of the following conditions:

- cooling load satisfied
- remote on/off contacts open
- programmed schedule
- emergency stop command from CCN
- general power failure
- blown fuse in control power feed disconnect
- open control circuit fuse(s)
- Enable/Off/Remote Contact switch moved to Off position
- freeze protection trip
- low flow protection trip
- open contacts in chilled water flow switch
- Open contacts in any auxiliary interlock. Terminals that are jumpered from factory are in series with control switch. Opening the circuit between these terminals places unit in Stop mode, similar to moving the control switch to Off position. Unit cannot start if these contacts are open. If they open while unit is running, the unit stops
- cooler entering or leaving fluid thermistor failure
- low/high transducer supply voltage
- loss of communications between the Main Base Board (MBB) and either the EXV board, AUX board or either CPM
- low refrigerant pressure
- off-to-on delay is in effect

⚠ CAUTION

If a stoppage occurs more than once as a result of any of the above safety devices, determine and correct the cause before attempting another restart.

Single Circuit Stoppage — Single circuit stoppage can be caused by the following:

- low oil pressure
- open contacts in high pressure switch
- low refrigerant pressure
- thermistor failure
- transducer failure
- alarm condition from CPM

Stoppage of one circuit by a safety device action does not affect other circuit. When a safety device trips, the circuit is shut down immediately and EXV closes. Refer to Table 28 for typical stoppage faults and reset types.

⚠ CAUTION

If a stoppage occurs more than once as a result of any of the preceding safety devices, determine and correct the cause before attempting another restart.

Restart Procedure — After the cause for stoppage has been corrected, restart is either automatic or manual, depending on the fault. Manual reset requires that the alarm(s) be reset via the Navigator. Select the RCRN item under the Alarms mode. Press **ENTER**, **▲** and **ENTER** again to reset all current alarms and alerts. A password entry may be required. Some typical fault conditions are described in Table 28. For a complete list of fault conditions, codes and reset type, see Table 29.

POWER FAILURE EXTERNAL TO THE UNIT — Unit restarts automatically when power is restored.

Table 28 — Typical Stoppage Faults and Reset Types

STOPPAGE FAULT	RESET TYPE
Loss of Condenser Flow (30HXC)	Manual reset
Cooler Freeze Protection (Chilled Fluid, Low Temperature)	Auto reset first time, manual if repeated in same day
Cooler Pump Interlock	Manual reset
Control Circuit Fuse Blown	Unit restarts automatically when power is restored
High-Pressure Switch Open	Manual reset
Low Sat. Suction Temperature	Manual reset after 1 hour
Low Oil Pressure	Manual reset
Loss of Communications with WSM or CSM Controller	Automatic reset

LEGEND

- CSM — Chillervisor™ System Manager
- WSM — Water System Manager

Alarms and Alerts — These are warnings of abnormal or fault conditions and may cause either one circuit or the whole unit to shut down. They are assigned code numbers and a detailed description of each alarm/alert code error including possible causes is shown in Table 29. The alarm descriptions are displayed on the Navigator under the ‘CRNT’ or ‘HIST’ sub-modes of the Alarms mode. The Main Base Board also recognizes and reports illegal configurations as shown in Table 29.

When an alarm or alert is activated, the alarm relay output (MBB relay K7, terminals TB5-11,12) is energized. The alarms and alerts indicate failures that cause the unit to shut down, terminate an option (such as reset) or result in the use of a default value such as a set point. Refer to Table 29 for more information.

Up to 50 alarms/alerts can be stored at once. Use Alarm and Alert tables to view and clear alarms. Reset the alarm(s) using the Navigator as shown in Table 23. For MTA setting fault alarms from the CPM, move the Enable/Off/Remote Contact switch to the Off position. Wait for all compressors to stop. Turn off the unit control power. Correct the configuration header problem and restore unit control power.

Compressor Alarm/Alert Circuit — Each compressor is directly controlled by a CPM module. Compressor faults (T051, T052, T055, T056) are reported as alerts. The specific fault condition for a compressor alert is included as part of the alert description displayed on the Navigator. Press **ESCAPE** and **ENTER** simultaneously to display description.

Table 29 — Alarm and Alert Codes

ALARM/ALERT CODE	ALARM OR ALERT	DESCRIPTION	WHY WAS THIS ALARM GENERATED?	ACTION TAKEN BY CONTROL	RESET METHOD	PROBABLE CAUSE
T026	Alert	Compressor A1 Low Oil Pressure – 1	$P_{O-P_e} < \text{Oil Set Point 1}$. See Note 1 and Fig. 18 on page 47.	Comp A1 shut down	Manual	Low Water Temperature, low refrigerant charge, plugged oil filter, closed oil valve, bad oil solenoid, compressor oil check valve stuck, oil line check valve stuck, plugged oil strainer
		Compressor A1 Low Oil Pressure – 2	$P_{O-P_s} < \text{Oil Set Point 2}$. See Note 1 and Fig. 18 on page 47.	Comp A1 shut down	Manual	Low Water Temperature, low refrigerant charge, plugged oil filter, closed oil valve, bad oil solenoid, compressor oil check valve stuck, oil line check valve stuck, plugged oil strainer
T027	Alert	Compressor A2 Low Oil Pressure – 1	$P_{O-P_e} < \text{Oil Set Point 1}$. See Note 1 and Fig. 18 on page 47.	Comp A2 shut down	Manual	Low Water Temperature, low refrigerant charge, plugged oil filter, closed oil valve, bad oil solenoid, compressor oil check valve stuck, oil line check valve stuck, plugged oil strainer
		Compressor A2 Low Oil Pressure – 2	$P_{O-P_s} < \text{Oil Set Point 2}$. See Note 1 and Fig. 18 on page 47.	Comp A2 shut down	Manual	Low Water Temperature, low refrigerant charge, plugged oil filter, closed oil valve, bad oil solenoid, compressor oil check valve stuck, oil line check valve stuck, plugged oil strainer
T028	Alert	Compressor B1 Low Oil Pressure – 1	$P_{O-P_e} < \text{Oil Set Point 1}$. See Note 1 and Fig. 18 on page 47.	Comp B1 shut down	Manual	Low Water Temperature, low refrigerant charge, plugged oil filter, closed oil valve, bad oil solenoid, compressor oil check valve stuck, oil line check valve stuck, plugged oil strainer
		Compressor B1 Low Oil Pressure – 2	$P_{O-P_s} < \text{Oil Set Point 2}$. See Note 1 and Fig. 18 on page 47.	Comp B1 shut down	Manual	Low Water Temperature, low refrigerant charge, plugged oil filter, closed oil valve, bad oil solenoid, compressor oil check valve stuck, oil line check valve stuck, plugged oil strainer
T029	Alert	Compressor B2 Low Oil Pressure – 1	$P_{O-P_e} < \text{Oil Set Point 1}$. See Note 1 and Fig. 18 on page 47.	Comp B2 shut down	Manual	Low Water Temperature, low refrigerant charge, plugged oil filter, closed oil valve, bad oil solenoid, compressor oil check valve stuck, oil line check valve stuck, plugged oil strainer
		Compressor B2 Low Oil Pressure – 2	$P_{O-P_s} < \text{Oil Set Point 2}$. See Note 1 and Fig. 18 on page 47.	Comp B2 shut down	Manual	Low Water Temperature, low refrigerant charge, plugged oil filter, closed oil valve, bad oil solenoid, compressor oil check valve stuck, oil line check valve stuck, plugged oil strainer
T030	Alert	Compressor A1 Pre-Start Oil Pressure	Oil Pump did not build sufficient pressure during pre-lube cycle.	Compressor cannot start.	Manual	Low oil, oil pump failure, oil solenoid failure, oil transducer failure, check valve failed open, oil shutoff valve closed.
T031	Alert	Compressor A2 Pre-Start Oil Pressure	Oil Pump did not build sufficient pressure during pre-lube cycle.	Compressor cannot start.	Manual	Low oil, oil pump failure, oil solenoid failure, oil transducer failure, check valve failed open, oil shutoff valve closed.
T032	Alert	Compressor B1 Pre-Start Oil Pressure	Oil Pump did not build sufficient pressure during pre-lube cycle.	Compressor cannot start.	Manual	Low oil, oil pump failure, oil solenoid failure, oil transducer failure, check valve failed open, oil shutoff valve closed.
T033	Alert	Compressor B2 Pre-Start Oil Pressure	Oil Pump did not build sufficient pressure during pre-lube cycle.	Compressor cannot start.	Manual	Low oil, oil pump failure, oil solenoid failure, oil transducer failure, check valve failed open, oil shutoff valve closed.

Table 29 — Alarm and Alert Codes (cont)

ALARM/ALERT CODE	ALARM OR ALERT	DESCRIPTION	WHY WAS THIS ALARM GENERATED?	ACTION TAKEN BY CONTROL	RESET METHOD	PROBABLE CAUSE
A034	Alarm	Comp. A1 Max. Oil Delta P, check oil line	(Discharge press – Oil press) > 100 PSI for more than 5 seconds	Comp. A1 shut down	Manual	Plugged oil filter, closed oil valve, bad oil solenoid, compressor oil check valve stuck, oil line check valve stuck, plugged oil strainer
A035	Alarm	Comp. A2 Max. Oil Delta P, check oil line	(Discharge press – Oil press) > 100 PSI for more than 5 seconds	Comp. A2 shut down	Manual	Plugged oil filter, closed oil valve, bad oil solenoid, compressor oil check valve stuck, oil line check valve stuck, plugged oil strainer
A036	Alarm	Comp. B1 Max. Oil Delta P, check oil line	(Discharge press – Oil press) > 100 PSI for more than 5 seconds	Comp. B1 shut down	Manual	Plugged oil filter, closed oil valve, bad oil solenoid, compressor oil check valve stuck, oil line check valve stuck, plugged oil strainer
A037	Alarm	Comp. B2 Max. Oil Delta P, check oil line	(Discharge press – Oil press) > 100 PSI for more than 5 seconds	Comp. B2 shut down	Manual	Plugged oil filter, closed oil valve, bad oil solenoid, compressor oil check valve stuck, oil line check valve stuck, plugged oil strainer
A038	Alarm	Comp. A1 Failed Oil Solenoid	Diff. Oil Pressure > 5.0 PSI during period after oil pump starts and before oil solenoid opens	Comp. A1 not allowed to start	Manual	Faulty oil solenoid valve
A039	Alarm	Comp. A2 Failed Oil Solenoid	Diff. Oil Pressure > 5.0 PSI during period after oil pump starts and before oil solenoid opens	Comp. A2 not allowed to start	Manual	Faulty oil solenoid valve
A040	Alarm	Comp. B1 Failed Oil Solenoid	Diff. Oil Pressure > 5.0 PSI during period after oil pump starts and before oil solenoid opens	Comp. B1 not allowed to start	Manual	Faulty oil solenoid valve
A041	Alarm	Comp. B2 Failed Oil Solenoid	Diff. Oil Pressure > 5.0 PSI during period after oil pump starts and before oil solenoid opens	Comp. B2 not allowed to start	Manual	Faulty oil solenoid valve

Table 29 — Alarm and Alert Codes (cont)

ALARM/ALERT CODE	ALARM OR ALERT	DESCRIPTION	WHY WAS THIS ALARM GENERATED?	ACTION TAKEN BY CONTROL	RESET METHOD	PROBABLE CAUSE
T051	Alert	Compressor A1 Failure – (See below)	See additional descriptions below.			
T052	Alert	Compressor A2 Failure – (See below)				
T055	Alert	Compressor B1 Failure – (See below)				
T056	Alert	Compressor B2 Failure – (Not Applicable)				
		High Pressure Switch Trip	HPS input to CPM module open	Comp. shut down	Manual	Loss of condenser air/water flow. Operation beyond chiller capability. Liquid valve not open.
		No Motor Current	CPM reads less than 10% of MTA on all legs for >3.0 seconds	Comp. shut down	Manual	Power supply disconnected, blown fuse(s), wiring error, contactor not energized, faulty current toroid, check toroid wiring.
		Current Unbalance	CPM measures current imbalance between phases must be above C.UNB for 25 minutes	Circuit shut down	Manual	Loose terminals on power wires. Alert will be generated if measured imbalance exceeds set point.
		Single Phase Current Loss	CPM measures current imbalance between phases greater than 50% (running current <50% of MTA) or 30% (running current ≥ 50% of MTA) for 1 second.	Circuit shut down	Manual	Blown fuse, wiring error, loose terminals
		High Motor Current	CPM detects high current compared to MTA setting	Comp. shut down	Manual	Operation beyond chiller capability, improperly punched configuration header, blown fuse
		Ground Fault Trip	CPM detects ground current (4.0 ± 2.0 amps)	Comp. shut down	Manual	Motor winding(s) gone to ground, wiring error, loose plug connector.
		Contactor Failure	CPM detects min. 10% of MTA for 10 seconds after shutting off compressor contactor. Oil solenoid is energized.	All remaining compressors shut down. All loaders deenergized. Min. load valve of affected circuit energized (if equipped)	Manual	Faulty contactor, contactor welded, wiring error.
		Current Phase Reversal	CPM detects phase reversal from toroid reading or from incoming power supply.	Circuit shut down	Manual	Terminal block power supply leads not in correct phase. Toroid wire harness crossed. Check compressor contactor.
		Motor Over Temperature	CPM detects motor winding temperature >245 F	Comp. shut down	Manual	Motor cooling (all) or Economizer (2 comp. circuits) solenoid failure, low refrigerant charge. Faulty economizer TXV or poor bulb connection to motor cooling line.
		Open Thermistor	CPM detects open circuit in motor temp thermistor	Comp. shut down	Manual	Wiring error or faulty thermistor*
		MTA Header Fault	CPM finds error with MTA value in DIP switch S2 setting.	Comp. shut down	Manual	DIP switch S2 not set correctly.
		MTA Value Error	MTA value stored in MBB does not agree with MTA in DIP switch S2 setting from CPM.	Comp. not allowed to start	Manual	DIP switch S2 not set correctly. See Appendix A. Incorrect size or voltage entered when MBB was downloaded.
		Shorted Thermistor	CPM detects short circuit in motor temp thermistor	Comp. shut down	Manual	Wiring error or faulty thermistor*
A060	Alarm	Cooler Leaving Fluid Thermistor Failure – 1	Thermistor outside range of –40 to 240° F (–40 to 116° C)	Chiller shut down	Automatic	Thermistor failure, damaged cable/wire or wiring error.
		Cooler Leaving Fluid Thermistor Failure – 2	LWT > EWT + 5° F for 15 minutes	Chiller shut down	Manual	Thermistor failure, damaged cable/wire, wiring error or water piping error.
A061	Alarm	Cooler Entering Fluid Thermistor Failure	Thermistor outside range of –40 to 240° F (–40 to 116° C)	Uses 0.1xF/% Total Capacity as rise/ton	Automatic	Thermistor failure, damaged cable/wire or wiring error.
T062	Alert	Condenser Leaving Fluid Thermistor Failure	Thermistor outside range of –40 to 240° F (–40 to 116° C)	None. Chiller continues to run.	Automatic	Thermistor failure, damaged cable/wire or wiring error.
T063	Alert	Condenser Entering Fluid Thermistor Failure	Thermistor outside range of –40 to 240° F (–40 to 116° C)	None. Chiller continues to run.	Automatic	Thermistor failure, damaged cable/wire or wiring error.
T070	Alert	Cir. A Discharge Gas Thermistor Failure	Average of compressor A1 and A2 (if installed) sensors > 210° F for 30 seconds.	Circuit A shut down	Manual	Thermistor failure, damaged cable/wire, wiring error or motor cooling solenoid failure.

Table 29 — Alarm and Alert Codes (cont)

ALARM/ ALERT CODE	ALARM OR ALERT	DESCRIPTION	WHY WAS THIS ALARM GENERATED?	ACTION TAKEN BY CONTROL	RESET METHOD	PROBABLE CAUSE
T071	Alert	Cir. B Discharge Gas Thermistor Failure	Average of compressor B1 and B2 (if installed) sensors > 210° F for 30 seconds.	Circuit B shut down	Manual	Thermistor failure, damaged cable/wire, wiring error or motor cooling solenoid failure.
T073	Alert	Outside Air Temperature Thermistor Failure	Thermistor outside range of -40 to 240 F (-40 to 116 C)	Reset disabled. Runs under normal control/set points.	Automatic	Thermistor failure, damaged cable/wire, wiring error or sensor not installed.
T074	Alert	Space Temperature Thermistor Failure	Thermistor outside range of -40 to 240 F (-40 to 116 C)	Reset disabled. Runs under normal control/set points.	Automatic	Thermistor failure, damaged cable/wire, wiring error or sensor not installed.
T075	Alert	Compressor A1 Discharge Gas Thermistor Failure	Thermistor outside range of -40 to 240° F (-40 to 116° C)	Comp A1 shut down	Automatic	Thermistor failure, damaged cable/wire, wiring error or motor cooling solenoid failure.
T076	Alert	Compressor A2 Discharge Gas Thermistor Failure	Thermistor outside range of -40 to 240° F (-40 to 116° C)	Comp A2 shut down	Automatic	Thermistor failure, damaged cable/wire, wiring error or motor cooling solenoid failure.
T077	Alert	Compressor B1 Discharge Gas Thermistor Failure	Thermistor outside range of -40 to 240° F (-40 to 116° C)	Comp B1 shut down	Automatic	Thermistor failure, damaged cable/wire, wiring error or motor cooling solenoid failure.
T078	Alert	Compressor B2 Discharge Gas Thermistor Failure	Thermistor outside range of -40 to 240° F (-40 to 116° C)	Comp B2 shut down	Automatic	Thermistor failure, damaged cable/wire, wiring error or motor cooling solenoid failure.
T079	Alert	Lead/Lag Leaving Fluid Temperature Thermistor Failure	Thermistor outside range of -40 to 240 F (-40 to 116 C)	Breaks Dual Chiller link if set up for Parallel operation.	Automatic	Thermistor failure, damaged cable/wire, wiring error or sensor not installed.
T090	Alert	Circuit A Discharge Pressure Transducer Failure	Voltage ratio more than 98.9% or less than 6%.	Circuit A shut down	Automatic	Transducer failure, poor connection to MBB, or wiring damage/error.
T091	Alert	Circuit B Discharge Pressure Transducer Failure	Voltage ratio more than 98.9% or less than 6%.	Circuit B shut down	Automatic	Transducer failure, poor connection to MBB, or wiring damage/error.
T092	Alert	Circuit A Suction Pressure Transducer Failure	Voltage ratio more than 99.9% or less than 0.5% for 50 seconds.	Circuit A shut down	Automatic	Transducer failure, poor connection to MBB, or wiring damage/error.
T093	Alert	Circuit B Suction Pressure Transducer Failure	Voltage ratio more than 99.9% or less than 0.5% for 50 seconds.	Circuit B shut down	Automatic	Transducer failure, poor connection to MBB, or wiring damage/error.
T094	Alert	Comp A1 Oil Pressure Transducer Failure	Voltage ratio more than 98.9% or less than 6%.	Comp A1 shut down	Automatic	Transducer failure, poor connection to CPM, or wiring damage/error.
T095	Alert	Comp A2 Oil Pressure Transducer Failure	Voltage ratio more than 98.9% or less than 6%.	Comp A2 shut down	Automatic	Transducer failure, poor connection to CPM, or wiring damage/error.
T096	Alert	Comp B1 Oil Pressure Transducer Failure	Voltage ratio more than 98.9% or less than 6%.	Comp B1 shut down	Automatic	Transducer failure, poor connection to CPM, or wiring damage/error.
T097	Alert	Comp B2 Oil Pressure Transducer Failure	Voltage ratio more than 98.9% or less than 6%.	Comp B2 shut down	Automatic	Transducer failure, poor connection to CPM, or wiring damage/error.
T098	Alert	Circuit A Economizer Pressure Transducer Failure - 1	Voltage ratio more than 99.9% or less than 0.5% for 50 seconds.	Circuit A shut down	Automatic	Transducer failure, poor connection to CPM, or wiring damage/error.
	Alert	Circuit A Economizer Pressure Transducer Failure - 2	Economizer pressure is more than 12 psi (83 kPa) less than suction pressure.	Circuit A shut down	Manual	Suction and Economizer pressure connectors/wiring are swapped.
T099	Alert	Circuit B Economizer Pressure Transducer Failure - 1	Voltage ratio more than 99.9% or less than 0.5% for 50 seconds.	Circuit B shut down	Automatic	Transducer failure, poor connection to CPM, or wiring damage/error.
	Alert	Circuit B Economizer Pressure Transducer Failure - 2	Economizer pressure is more than 12 psi (83 kPa) less than suction pressure.	Circuit B shut down	Manual	Suction and Economizer pressure connectors/wiring are swapped.
T110	Alert	Circuit A Loss of Charge	Discharge pressure reading < 10 psig for 30 seconds.	Circuit A shut down	Manual	Refrigerant leak or transducer failure.
T111	Alert	Circuit B Loss of Charge	Discharge pressure reading < 10 psig for 30 seconds.	Circuit B shut down	Manual	Refrigerant leak or transducer failure.

Table 29 — Alarm and Alert Codes (cont)

ALARM/ ALERT CODE	ALARM OR ALERT	DESCRIPTION	WHY WAS THIS ALARM GENERATED?	ACTION TAKEN BY CONTROL	RESET METHOD	PROBABLE CAUSE
T120	Alert	Circuit A Low Saturated Suction Temperature	SST reads 6° F (3.3° C) or more below the brine freeze point for 3 minutes or 28° F below brine freeze point for 2 minutes.	Circuit A shut down	Manual†	Low refrigerant charge, plugged strainer, faulty expansion valve, or low water flow.
T121	Alert	Circuit B Low Saturated Suction Temperature	SST reads 6° F (3.3° C) or more below the brine freeze point for 3 minutes or 28° F below brine freeze point for 2 minutes.	Circuit B shut down	Manual†	Low refrigerant charge, plugged strainer, faulty expansion valve, or low water flow.
T122	Alert	Circuit A High Saturated Suction Temperature	After first 90 seconds, SST > 55 F (12.8 C) and EXV < 1% for 5 minutes.	Circuit A shut down	Manual	Faulty expansion valve or transducer.
T123	Alert	Circuit B High Saturated Suction Temperature	After first 90 seconds, SST > 55 F (12.8 C) and EXV < 1% for 5 minutes.	Circuit B shut down	Manual	Faulty expansion valve or transducer.
T124	Alert	Circuit A Low Oil Level/Flow	Level switch input open.	Circuit A shut down after 4th failure in 18 hours.	Manual	Low oil level, failed switch, wiring error, failed control module.
T125	Alert	Circuit B Low Oil Level/Flow	Level switch input open.	Circuit B shut down after 4th failure in 18 hours.	Manual	Low oil level, failed switch, wiring error, failed control module.
T126	Alert	Circuit A High Discharge Pressure	SCT > MCT_SP + 5° F (2.8° C)	Circuit A shut down.	Automatic**	Faulty transducer/high pressure switch, low/restricted condenser air/water flow††
T127	Alert	Circuit B High Discharge Pressure	SCT > MCT_SP + 5° F (2.8° C)	Circuit B shut down.	Automatic**	Faulty transducer/high pressure switch, low/restricted condenser air/water flow††
A128	Alarm	Circuit A Condenser Freeze Protection (alarm ignored for brine chillers)	For water cooled chillers only, if SCT < 34 F (1.1° C)	Chiller shut down. Turns condenser pump On if Chiller is Off.	Automatic	Failed/bad discharge pressure transducer, refrigerant leak, configured for water-cooled condenser.
A129	Alarm	Circuit B Condenser Freeze Protection (alarm ignored for brine chillers)	For water cooled chillers only, if SCT < 34 F (1.1° C)	Chiller shut down. Turns condenser pump On if Chiller is Off.	Automatic	Failed/bad discharge pressure transducer, refrigerant leak, configured for water-cooled condenser.
T135	Alert	Circuit A Failure to Pump Out	With EXV closed, SST did not drop 10° F (5.6° C) in 6 minutes, or SST is not 6° F (3.3° C) less than Brine Freeze, or SST is not less than 10 F (-12 C).	None	Manual	Faulty transducer or EXV.
T136	Alert	Circuit B Failure to Pump Out	With EXV closed, SST did not drop 10° F (5.6° C) in 6 minutes, or SST is not 6° F (3.3° C) less than Brine Freeze, or SST is not less than 10 F (-12 C).	None	Manual	Faulty transducer or EXV
T137	Alert	Circuit A Low Discharge Superheat	Superheat < 5° F (2.8° C) for 10 minutes.	Circuit A shut down	Manual	Faulty thermistor, transducer, EXV, or Economizer TXV. Motor cooling solenoid stuck open.
T138	Alert	Circuit B Low Discharge Superheat	Superheat < 5° F (2.8° C) for 10 minutes.	Circuit B shut down	Manual	Faulty thermistor, transducer, EXV, or Economizer TXV. Motor cooling solenoid stuck open.
T140	Alert	Compressor A1 – High Oil Filter Pressure Drop	Oil filter pressure drop (FD.A1) exceeds 25 psig (172 kPa) for water-cooled units or 30 psig (207 kPa) for air-cooled and split system units.	None	Manual	Filter change needed to prevent machine from shutting down.
T141	Alert	Compressor A2 – High Oil Filter Pressure Drop	Oil filter pressure drop (FD.A2) exceeds 25 psig (172 kPa) for water-cooled units or 30 psig (207 kPa) for air-cooled and split system units.	None	Manual	Filter change needed to prevent machine from shutting down.

Table 29 — Alarm and Alert Codes (cont)

ALARM/ALERT CODE	ALARM OR ALERT	DESCRIPTION	WHY WAS THIS ALARM GENERATED?	ACTION TAKEN BY CONTROL	RESET METHOD	PROBABLE CAUSE
T142	Alert	Compressor B1 – High Oil Filter Pressure Drop	Oil filter pressure drop (FD.B1) exceeds 25 psig (172 kPa) for water-cooled units or 30 psig (207 kPa) for air-cooled and split system units.	None	Manual	Filter change needed to prevent machine from shutting down.
T143	Alert	Compressor B2 – High Oil Filter Pressure Drop	Oil filter pressure drop (FD.B2) exceeds 25 psig (172 kPa) for water-cooled units or 30 psig (207 kPa) for air-cooled and split system units.	None	Manual	Filter change needed to prevent machine from shutting down.
A150	Alarm	Unit is in Emergency Stop	CCN command received to shut unit down	Chiller shut down	CCN/ Automatic	Network command
A151	Alarm	Illegal Configuration-x	Illegal Configuration has been entered. Correction needed.	Chiller cannot start.	Manual	Configuration error. See Table 30.
A152	Alarm	Circuit A&B Off for Alerts. Unit down.	Control has shut down both circuits due to alerts.	None	Automatic	Check individual alarms.
T153	Alert	Real Time Clock Hardware Failure	Time not advancing on board,	Defaults to occupied	Automatic	Time clock not initialized or board fail
A154	Alarm	Serial EEPROM Hardware Failure	Internal failure of the EEPROM.	Machine shuts down	Manual	Replace Main Base Board.
A155	Alarm	Serial EEPROM Storage Failure Error	Internal diagnostic has found an error on critical data.	Machine shuts down	Manual	Re-download the software of consider replacement of the Main Base Board.
A156	Alarm	Critical Serial EEPROM Storage Failure Error	Internal diagnostic has found an error on critical data.	Machine shuts down	Manual	Replace Main Base Board.
A157	Alarm	A/D Hardware Failure	A/D converter on the MBB has failed.	Machine shuts down	Manual	Replace Main Base Board.
A159	Alarm	Loss of Condenser Flow	Flow switch not closed within 1 minute after pump is started or if flow switch opens during normal operation for > 10 sec.	Chiller shut down.	Manual	Low condenser water flow, failed condenser pump.
A172	Alarm	Loss of Communication with EXV Module	MBB has lost communication with the EXV Module	Chiller shut down.	Automatic	Failed EXV Module, wiring error, loose connections, failed transformer, wrong address.
T173	Alert	Loss of Communication with Energy Management Module	MBB has lost communication with the Energy Management Module when this option is installed.	EMM options are disabled.	Automatic	Failed EMM, wiring error, loose connections, failed transformer, wrong address, wrong configuration.
T174	Alert	4-20 mA Cool Setpoint Input Failure	If configured and input signal to EMM less than 2 mA or greater than 22 mA.	Function disabled. Normal set point used.	Automatic	Faulty signal generator, wiring error, loss of signal
T175	Alert	4-20 mA Heat Setpoint Input Failure	If configured and input signal to EMM less than 2 mA or greater than 22 mA.	Function disabled. Normal set point used.	Automatic	Faulty signal generator, wiring error, loss of signal
T176	Alert	4-20 mA Reset Input Out of Range	If configured and input signal to EMM less than 2 mA or greater than 22 mA.	Reset function disabled. Normal set point used.	Automatic	Faulty signal generator, wiring error loss of signal
T177	Alert	4-20 mA Demand Limit Input Out of Range	If configured and input signal to EMM less than 2 mA or greater than 22 mA.	Reset function disabled. Normal set point used.	Automatic	Faulty signal generator, wiring error, loss of signal

Table 29 — Alarm and Alert Codes (cont)

ALARM/ALERT CODE	ALARM OR ALERT	DESCRIPTION	WHY WAS THIS ALARM GENERATED?	ACTION TAKEN BY CONTROL	RESET METHOD	PROBABLE CAUSE
A200	Alarm	Cooler Pump Interlock Failed at Start-Up	Interlock did not close within 5 minutes after chiller was enabled	Chiller shut down. Pump turned off.	Manual	Failure of cooler pump, cooler pump interlock, or flow switch
A201	Alarm	Cooler Pump Interlock Opened Unexpectedly	Interlock opened for at least 10 seconds during operation and does not close within 5 min.	Chiller shut down. Pump turned off.	Manual	Failure of cooler pump, cooler pump interlock, or flow switch
A202	Alarm	Cooler Pump Interlock Closed When Pump OFF	Interlock closed when pump relay is off	Cooler pump remains off. Unit prevented from starting.	Manual	Failure of cooler pump relay or interlock, welded contacts. Cooler pump enabled but not controlling pump
T203	Alert	Loss of Communication with the Slave Chiller	The master chiller (when configured) has lost communication with the slave chiller for 3 minutes.	Master chiller runs as a stand-alone chiller.	Automatic	Failed Slave MBB Module, wiring error, loose connections, wrong address, loss of control power on slave chiller.
T204	Alert	Loss of Communication with the Master Chiller	The slave chiller (when configured) has lost communication with the master chiller for 3 minutes.	Slave chiller runs as a stand-alone chiller.	Automatic	Failed Master MBB Module, wiring error, loose connections, wrong address, loss of control power on master chiller.
T205	Alert	Master and Slave Chiller with Same Address	The master chiller (when configured) has determined that its address is the same as the slave address.	Dual chiller control disabled.	Automatic	Master and Slave chiller must have different addresses.
T206	Alert	High Leaving Chilled Water Temperature	LCW read > LCW Delta Alarm limit and total capacity is 100% and current LCW > LCW reading 1 minute ago	None.	Automatic	Building load greater than unit capacity, low water/brine flow, or compressor fault. Check for other alarms or alerts.
A207	Alarm	Cooler Freeze Protection	Cooler EWT or LWT less than freeze point. Freeze point is the brine freeze setpoint +2 F (1.1 C).	Chiller shut down. Leave Cooler pump on. Turn Cooler pump on if Chiller is off.	Automatic	Faulty thermistor, low water flow. Manual reset after second occurrence within 18 hours.
T210	Alert	Winterization Required	SCT<32 F in either circuit	None	Manual	Winterization must be performed to avoid cooler freeze-up. After winterization has been completed, configure W.DNE <i>Winterization Performed</i> (Configuration Mode, Sub-mode SERV) to YES to reset alert.
A211	Alarm	Loss of Communication with AUX Board	MBB has lost communication with the AUX board	Chiller shut down.	Automatic	Failed AUX board, wiring error, loose connections, failed transformer, wrong address.
T212	Alert	Loss of Communication with Compressor Protection Module A1	MBB has lost communication with the Compressor Protection Module A1	Chiller shut down.	Automatic	Failed CPM Module, wiring error, loose connections, failed transformer, wrong address.
T213	Alert	Loss of Communication with Compressor Protection Module B1	MBB has lost communication with the Compressor Protection Module B1	Chiller shut down.	Automatic	Failed CPM Module, wiring error, loose connections, failed transformer, wrong address.
T214	Alert	Loss of Communication with Compressor Protection Module A2	MBB has lost communication with the Compressor Protection Module A2	Chiller shut down.	Automatic	Failed CPM Module, wiring error, loose connections, failed transformer, wrong address.
T215	Alert	Loss of Communication with Compressor Protection Module B2	MBB has lost communication with the Compressor Protection Module B2	Chiller shut down.	Automatic	Failed CPM Module, wiring error, loose connections, failed transformer, wrong address.
T950	Alert	Loss of Communication with WSM	No communications have been received by the MBB within 5 minutes of transmission.	WSM forces removed. Runs under own control.	Automatic	Failed module, wiring error, failed transformer, loose connection plug, wrong address
A951	Alarm	Loss of Communication with Chillervisor System Manager (CSM)	No communications have been received by the MBB within 5 minutes of last transmission.	CSM forces removed. Runs under own control.	Automatic	Wiring faulty or module failure
T998	Alert	Loss of Refrigerant Flow in Circuit A.	Between 40 and 90 seconds of runtime, SST is less than 0° F (-18 C) and the rate of change is negative (in 5 second increments).	Circuit A compressor is shut down.	Manual	Refrigerant restriction such as closed suction service valve, closed liquid line service valve, faulty liquid line solenoid valve, faulty EXV/Economizer operation, plugged refrigerant strainer, closed discharge line valve. Automatic reset after 15 minutes.
T999	Alert	Loss of Refrigerant Flow in Circuit B.	Between 40 and 90 seconds of runtime, if SST is less than 0° F (-18 C) and the rate of change is negative (in 5 second increments).	Circuit B compressor is shut down.	Manual	Refrigerant restriction such as closed suction service valve, closed liquid line service valve, faulty liquid line solenoid valve, faulty EXV/Economizer operation, plugged refrigerant strainer, closed discharge line valve. Automatic reset after 15 minutes.

LEGEND AND NOTES FOR TABLE 29

LEGEND

AUX	— Auxiliary Board
CCN	— Carrier Comfort Network®
CPM	— Compressor Protection Module
EMI	— Electromagnetic Interference
EMM	— Energy Management Module
EWT	— Entering Water Temperature
EXV	— Electronic Expansion Valve
HPS	— High-Pressure Switch
LCW	— Leaving Chilled Water
LWT	— Leaving Water Temperature
MBB	— Main Base Board
MCT_SP	— Maximum Condensing Temperature Set Point
MTA	— Compressor Must Trip Amps
SCT	— Saturated Condensing Temperature
SST	— Saturated Suction Temperature
TXV	— Thermostatic Expansion Valve
WSM	— Water-System Manager

*Compressors are equipped with 2 motor winding temperature thermistors. Verify first that the problem is not a wiring error before using backup thermistor.

†Manual reset after 1 hour from occurrence.

**Reset automatic first time, manual if repeated on the same date.

††Note that the high-pressure switch should trip before this alert is generated. Check HPS operation if this alert is generated.

NOTES:

- Low Oil Pressure Alert Criteria and Set Points
Where: P_d = Discharge Pressure, P_s = Suction Pressure.
 P_o = Oil Pressure and P_e = Economizer Pressure
Two oil set points are used by the control for the Low Oil Pressure alert trip.

Oil Set Point 1 is defined as:

- If $P_s < 35$, then Oil Set Point 1 = 10 psig.
- If $P_s > 35$ and < 51 , then Oil Set Point 1 = 12.5 psig.
- If $P_s \geq 51$, then Oil Set Point 1 = 15 psig.

Oil Set Point 2 (see Fig. 18) is defined as:

- If $(P_d - P_s) < 125$, then Oil Set Point 2 = $0.235 \times (P_d - P_s) + 0.588$
 - If $(P_d - P_s) > 125$ and < 165 , then Oil Set Point 2 = $2.0 \times (P_d - P_s) - 220.0$
 - If $(P_d - P_s) \geq 165$ then Oil Set Point 2 = $0.6364 \times (P_d - P_s) + 5.0$
- $(P_o - P_e)$ is the Oil pressure differential displayed as items DO.A1 and DO.A2 (Pressures mode under sub-mode PRC.A) for Circuit A and DO.B1 (Pressures mode under sub-mode PRC.B) for Circuit B.
 - Alert criteria is based on operating time.
 - On time less than 5 seconds oil pressure is ignored.
 - On time between 5 and 120 seconds, the alert will be generated if the following condition is true for 3 consecutive readings:
 $(P_o - P_e) < [15 \text{ psig}/120 \text{ sec.}] \times [\text{Compressor Run Time in sec.}]$
 - On time greater than 120 seconds the alarm will be generated if one of the following conditions is true:
 $(P_o - P_e) < \text{Oil Set Point 1 for 15 seconds.}$
 $(P_o - P_s) < \text{Oil Set Point 2 for 15 seconds.}$

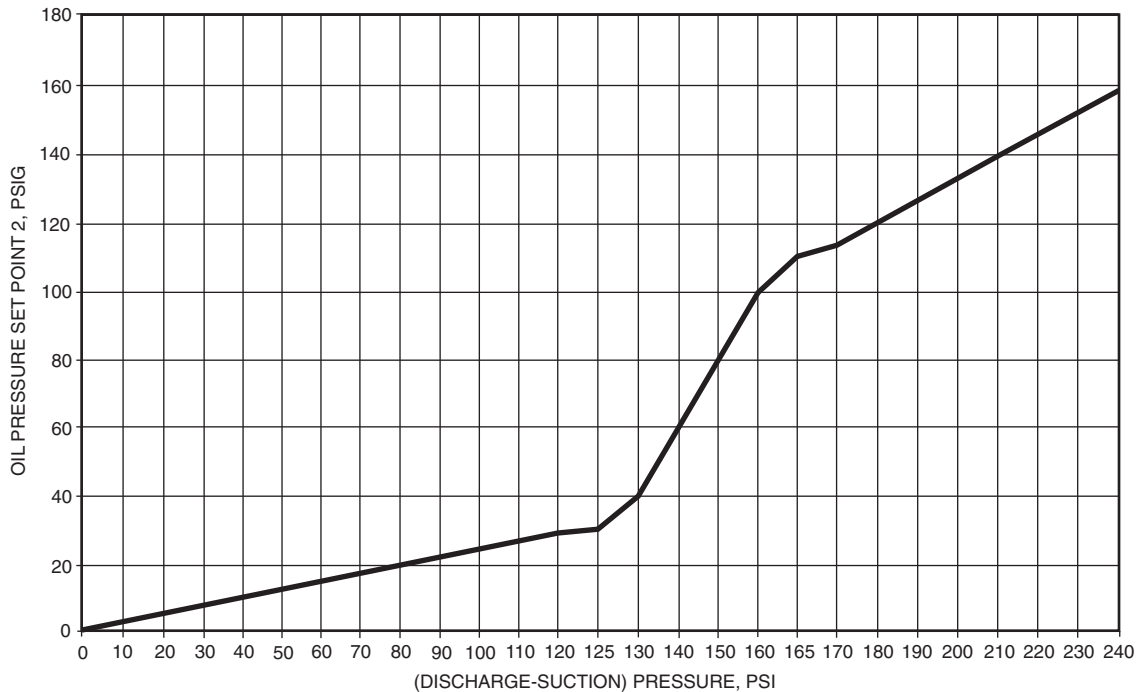

Fig. 18 — Oil Pressure Set Point 2 Calculation

Table 30 — Illegal Configurations (Alarm A151)

CODE NUMBER	ILLEGAL CONFIGURATION DESCRIPTION
1	Unit type outside range of 1-5
2	Number of compressors in Circuit A outside range of 1-2
3	Number of compressors in Circuit B outside range of 1-2
4	Invalid FAN.S or HPCT Selection
5	Air-cooled chiller with Low Temperature Brine fluid (FLUD = Low Brine)
6	Water-cooled chiller configured for air-cooled head pressure control type (HPCT)
7	Air-cooled chiller with condenser pump control enabled
8	Air-cooled chiller with condenser fluid sensors enabled

EXV Troubleshooting Procedure — Follow steps below to diagnose and correct EXV/Economizer problems.

Check EXV motor operation first. Switch the Enable/Off/Remote (EOR) Contact switch to the Off position. Press **ESCAPE** on the Navigator until ‘Select a menu item’ appears on the display. Use the arrow keys to select the Service Test mode. Press **ENTER**. The display will be:

```
> TEST      OFF
      OUTFS
      COMP
```

Press **ENTER** (password entry may be required) and use **▲** to change ‘OFF’ to ‘ON’. Switch the EOR switch to Enable. The Service Test mode is now enabled. Move the pointer down to the OUTFS sub-mode and press **ENTER**. Move the pointer to item EXV.A or EXV.B as needed. Press **ENTER** and the valve position will flash. Use **▲** to select 100% valve position (hold **▲** for quick movement) and press **ENTER**.

You should be able to feel the actuator moving by placing your hand on the EXV. A sight glass is located on the valve body to verify that the sleeve is moving to expose/cover slots in the orifice. A hard knocking should be felt from the actuator when it reaches the top of its stroke (can be heard if surroundings are relatively quiet). Press **ENTER** again twice if necessary to confirm this. To close the valve, press **ENTER**, select 0% with **▼** and press **ENTER**. The actuator should knock when it reaches the bottom of its stroke. If it is believed that the valve is not working properly, continue with the checkout procedure below:

Check the EXV output signals at appropriate terminals on the EXV module (see Fig. 19). Connect positive test lead to EXV-J6 terminal 3 for Circuit A, EXV-J7 terminal 3 for Circuit B. Set meter to approximately 20 vdc. Using the Service Test procedure above, move the valve output under test to 100%. DO NOT short meter leads together or pin 3 to any other pin as board damage will occur. During the next several seconds, carefully connect the negative test lead to pins 1,2,4 and 5 in succession (plug J6 for Circuit A, plug J7 for Circuit B). Digital voltmeters will average this signal and display approximately 6 vdc. If it remains constant at a voltage other than 6 VDC or shows 0 volts, remove the connector to the valve and recheck.

The EXV motor moves at 300 steps per second. Commanding the valve to either 0% or 100% will add 7500 steps to the move. For example, if the EXV is fully closed, selecting 100% would allow 75 seconds for the dc voltage to be checked ($15,000/300 + 7500/300$).

Press **ENTER** and select 0% to close the valve. Check the 4 position DIP switch on the board (all switches should be set to On). If a problem still exists, replace the EXV module. If the reading is correct, the expansion valve and EXV wiring should be checked. Check the EXV terminal strip and interconnecting wiring.

1. Check color coding and wire connections. Make sure they are connected to the correct terminals at the EXV driver and EXV plug and that the cables are not crossed.
2. Check for continuity and tight connection at all pin terminals.

Check the resistance of the EXV motor windings. Remove the EXV module plug (J6 for Circuit A, J7 for Circuit B) and check the resistance of the two windings between pins 1 and 2 for one winding and pins 4 and 5 for the other winding (see Fig. 19). The resistance should be 75 ohms ± 7.5 ohms.

INSPECTING/OPENING ELECTRONIC EXPANSION VALVES

IMPORTANT: Obtain replacement O-ring before opening EXV. Do not reuse O-rings.

To check the physical operation of an EXV, the following steps must be performed.

1. Close the liquid line service valve of the circuit to be checked. Put the Enable/Off/Remote Contact switch in the Off position. Using the Navigator, enter the Service Test mode and change the sub-mode TEST from ‘OFF’ to ‘ON’. Switch the EOR switch to the Enable position. Under the COMP sub-mode, enable the desired compressor (CC.xx) for the circuit. Let compressor run until gage on suction pressure port reads 10 psig. Press **ENTER**, **▼** and **ENTER** to turn the compressor off. The compressor will complete its pumpout routine and turn off. Immediately after the compressor shuts off, close the discharge valve.
2. Remove any remaining refrigerant from the system low side using proper reclaiming techniques. Drain oil from cooler using Schrader port in cooler inlet line.
3. The expansion valve motor is hermetically sealed inside the top portion of the valve. Carefully unscrew the large retaining nut securing the motor portion to the body of the valve making sure the EXV plug is still connected. The EXV lead screw and sleeve will come off with the motor portion of the device.
4. Enter the appropriate EXV test step under the OUTFS sub-mode in the Service Test mode. Locate the desired item ‘EXV.A’ or ‘EXV.B’. Press **ENTER** to make the valve position of 0% flash. Press and hold **▲** until 100% is displayed and press **ENTER**. Observe the operation of the lead screw and sleeve. The motor should be turning the lead screw and sleeve counterclockwise, raising the sleeve closer to the motor. Lead screw movement should be smooth and uniform from fully closed to fully open position. Press **ENTER**, use **▼** to select 0% and press **ENTER** again to check open to closed operation. If the valve is properly connected to the processor and receiving correct signals, yet does not operate as described above, the sealed motor portion of the valve should be replaced.

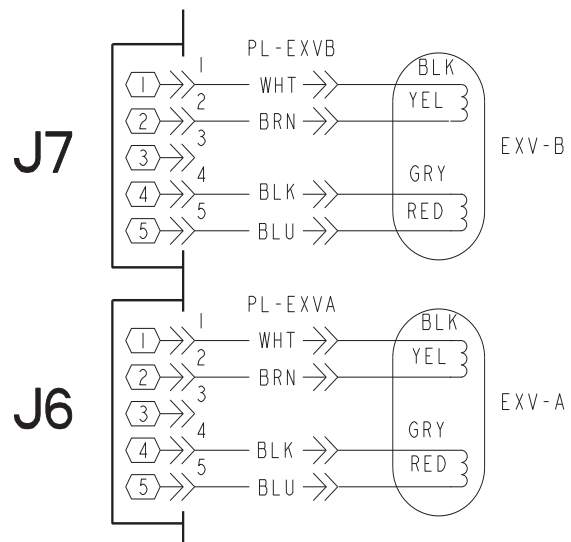

Fig. 19 — EXV Cable Connections to EXV Module

BRAZED-PLATE ECONOMIZERS — Brazed-plate economizers are factory-installed in each circuit on 30HXA,C161-271 models. A TXV (thermostatic expansion valve) is included to meter the flow of refrigerant to the economizer port of the compressor. The TXV bulb is secured to the side of the economizer outlet tube. See Fig. 20 for typical piping arrangement.

Brazed-plate heat exchangers cannot be repaired if they develop a leak. If a refrigerant leak is detected, the heat exchanger **must be** replaced. To replace a brazed-plate heat exchanger the following steps must be performed:

1. Using proper techniques, move the refrigerant remaining in the circuit to the high side and close the discharge and liquid line ball valves. Reclaim any refrigerant remaining in the low side.
2. Un-solder the refrigerant-in and refrigerant-out connections.
3. Remove the four 1/4-20 nuts holding the heat exchanger to the brackets. Save the nuts and hardware.
4. Check that the replacement heat exchanger is the same as the original heat exchanger.
5. Insulate the new heat exchanger to match the original and attach to the mounting brackets with the hardware removed in Step 3.
6. *Carefully* braze the refrigerant lines to the connections on the heat exchanger. Lines should be soldered using silver as the soldering material with a minimum of 45% silver. Keep the temperature below 1472 F (800 C) under normal soldering conditions (no vacuum) to prevent the copper solder of the brazed plate heat exchanger from changing its structure. Failure to do so can result in internal or external leakage at the connections which cannot be repaired.
7. Braze equalizer line in place if removed. Attach economizer and motor cooling solenoid coils to their bodies if removed.
8. Dehydrate and recharge the circuit. Check for leaks.

NOTE: The brazed-plate heat economizers are not serviceable.

If operating problems persist after economizer replacement, they may be due to a faulty suction pressure transducer or discharge gas thermistor or intermittent connections between the processor board terminals and EXV plug. Recheck all wiring connections and voltage signals.

Other possible causes of improper refrigerant flow control could be restrictions in the liquid line. Check for plugged strainer(s) or restricted metering slots in the EXV (see Fig. 21). Formation of ice or frost on lower body of electronic expansion valve is one symptom of restricted metering slots. However, frost or ice formation is normally expected when leaving fluid temperature from the cooler is below 40 F (4.4 C). Clean or replace valve if necessary.

NOTE (non-economized units only): Frosting of valve is normal during compressor test steps and at initial start-up. Frost should dissipate after 5 to 10 minutes operation in a system that is operating properly. If valve is to be replaced, wrap valve with a wet cloth to prevent excessive heat from damaging internal components.

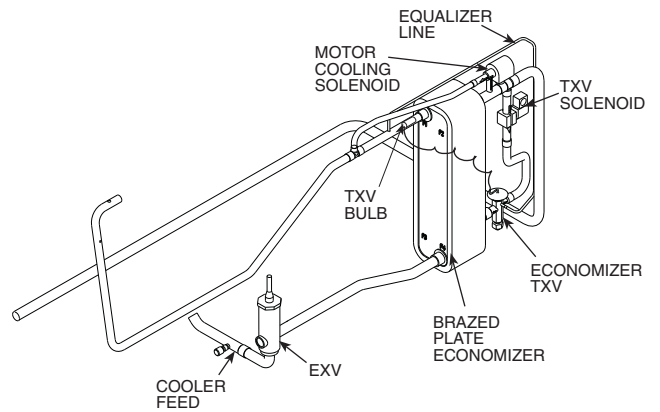
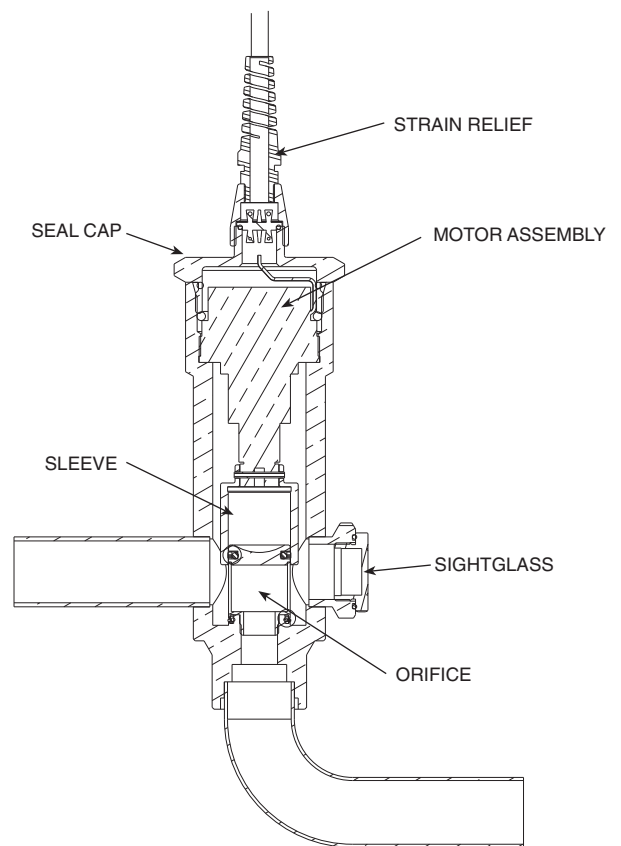

Fig. 20 — Brazed-Plate Economizer



Torque Specifications

ITEM	ft-lb	n-m
Sight Glass	15-25	20-34
Seal Cap	18-22	24-30

Fig. 21 — Typical 30HX EXV

SERVICE

Servicing Coolers and Condensers — When cooler heads and partition plates are removed, tube sheets are exposed showing the ends of tubes. The 30HX units use a flooded cooler design. Water flows inside the tubes.

TUBE PLUGGING — A leaky tube in one circuit can be plugged until retubing can be done. The number of tubes plugged determines how soon the cooler must be retubed. All tubes in the 30HX coolers and condensers can be removed. Loss of unit capacity and efficiency as well as increased pump power will result from plugging tubes. Failed tubes should be replaced as soon as possible. Up to 10% of the total number of tubes per pass can be plugged before retubing is necessary. Figure 22 shows an Elliott tube plug and a cross-sectional view of a plug in place. The same components for plugging and rolling tubes can be used for all coolers and 30HXC condensers. See Table 31. If tube failure is in both circuits, using tube plugs will not correct problem. Contact your Carrier representative for assistance.

CAUTION

Use extreme care when installing plugs to prevent damage to the tube sheet section between the holes.

RETUBING (See Table 32) — When retubing is to be done, obtain service of qualified personnel experienced in boiler maintenance and repair. Most standard procedures can be followed when retubing the 30HX heat exchangers. Care must be taken as the tubes are rolled in the center tube sheet and require special pulling tools. A 7% crush is recommended when rolling replacement tubes into the tubesheet. A 7% crush can be achieved by setting the torque on the gun at 48 to 50 in.-lb (5.4 to 5.6 N-m).

Place one drop of Loctite No. 675 or equivalent on top of tube prior to rolling. This material is intended to “wick” into the area of the tube that is not rolled into the tube sheet, and prevent fluid from accumulating between the tube and the tube sheet. New tubes must also be rolled into the center tube sheet to prevent circuit-to-circuit refrigerant leakage.

Table 31 — Plugging Components

COMPONENTS FOR PLUGGING	PART NUMBER
For Tubes	
Brass Pin	853103-1*
Brass Ring	853002-640* or -657†
For Holes without Tubes	
Brass Pin	853103-1A*
Brass Ring	853002-738*
Roller Extension	S82-112/11
Loctite	No. 675**
Locquic	“N”***

*Order directly from: Elliott Tube Company, Dayton, Ohio.

†Measure tube ID before ordering.

**Can be obtained locally.

Table 32 — Tube Diameters

ITEM	INCHES	MILLIMETERS
Tube sheet hole diameter:	0.756	19.20
Tube OD	0.750	19.05
Tube ID after rolling:	0.650	16.51
(includes expansion due to clearance)	to 0.667	to 16.94

NOTE: Tubes replaced along heat exchanger head partitions must be flush with tube sheet.

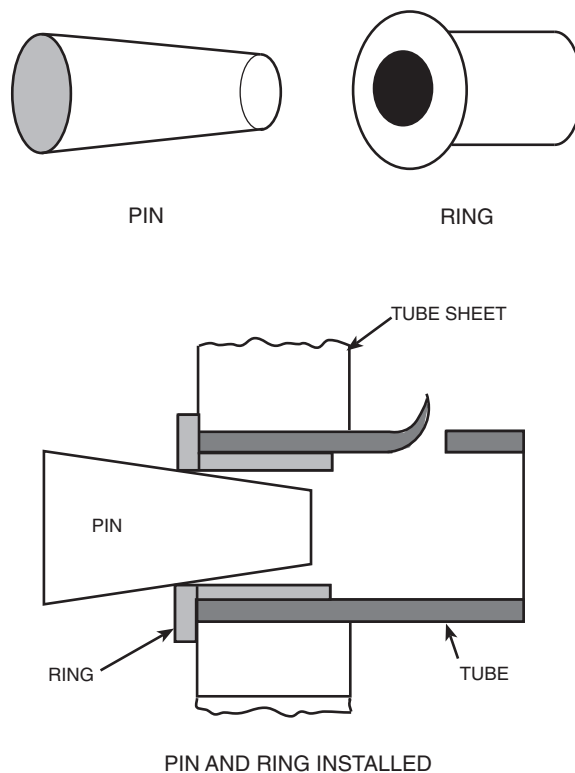

Fig. 22 — Tube Plugging

TIGHTENING COOLER/CONDENSER HEAD BOLTS

O-Ring Preparation — When reassembling cooler and condenser heads, always check the condition of the O-ring(s) first. The O-ring should be replaced if there are any visible signs of deterioration, cuts or damage. Apply a thin film of grease to the O-ring before installation. This will aid in holding the O-ring into the groove while the head is installed. Torque all bolts to the following specification and in the sequence shown in Fig. 23.

$\frac{3}{4}$ -in. Diameter Perimeter and Plate Bolts..... 200 to 225 ft-lb (271 to 305 N-m)

1. Install all bolts finger tight.
2. Follow numbered sequence shown for head type being installed. This will apply even pressure to the O-ring.
3. Apply torque in one-third steps until required torque is reached. Load all bolts to each one-third step before proceeding to the next one-third step.
4. No less than one hour later, retighten all bolts to required torque values.
5. Restore water/brine flow and check for leaks. Fix leaks as necessary. Replace insulation (on cooler heads only).

Inspecting/Cleaning Heat Exchangers

COOLERS — Inspect and clean the cooler tubes at the end of the first operating season. Because these tubes have internal ridges, a rotary-type tube cleaning system is necessary to fully clean the tubes. Tube condition in the cooler will determine the scheduled frequency for cleaning, and will indicate whether water treatment is adequate in the chilled water/brine circuit. Inspect the entering and leaving thermistors for signs of corrosion or scale. Replace the sensor if corroded or remove any scale if found.

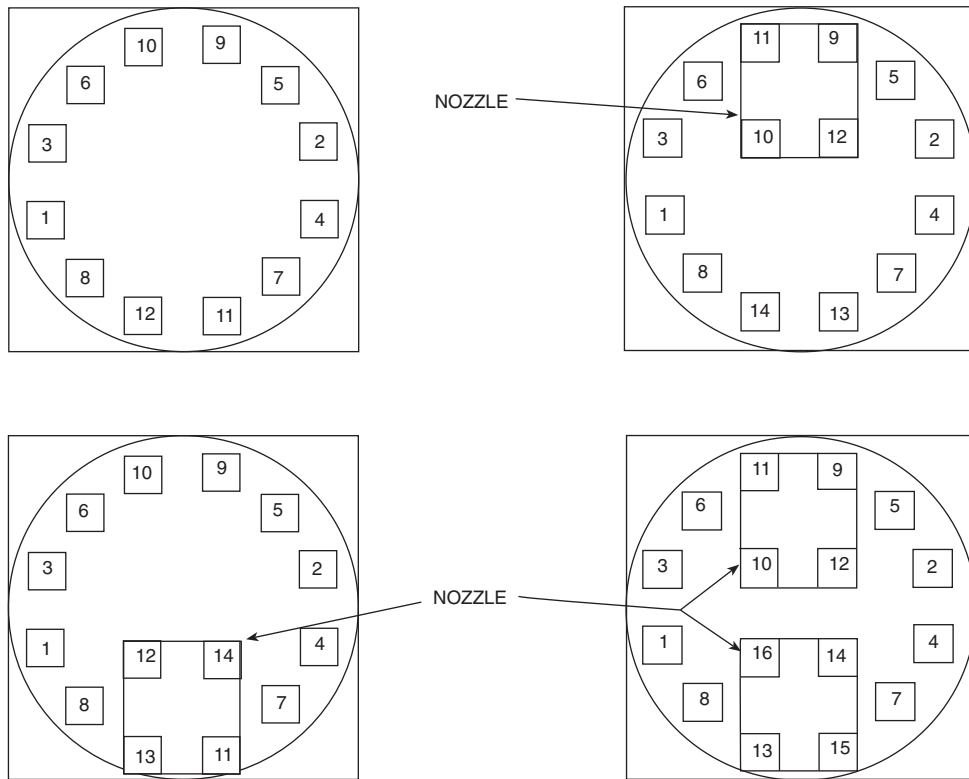

Fig. 23 — Cooler and Condenser Head Recommended Bolt Torque Sequence

CONDENSERS — Since this water circuit is usually an open-type system, the tubes may be subject to contamination and scale. Clean the condenser tubes with a rotary tube cleaning system at regular intervals, and more often if the water is contaminated. Inspect the entering and leaving condenser water thermistors (if installed) for signs of corrosion or scale. Replace the sensor if corroded or remove any scale if found.

Higher than normal condenser pressures, together with inability to reach full refrigeration load, usually indicate dirty tubes or air in the machine. If the refrigeration log indicates a rise above normal condenser pressures, check the condenser refrigerant temperature against the leaving condenser water temperature. If this reading is more than what the design difference is supposed to be, then the condenser tubes may be dirty, or water flow may be incorrect. Due to the pressure in the R-134a system, air usually will not enter the machine; the refrigerant will leak out.

During the tube cleaning process, use brushes specially designed to avoid scraping and scratching the tube wall. Contact your Carrier representative to obtain these brushes. Do not use wire brushes.

⚠ CAUTION

Hard scale may require chemical treatment for its prevention or removal. Consult a water treatment specialist for proper treatment procedures.

Water Treatment — Untreated or improperly treated water may result in corrosion, scaling, erosion, or algae. The services of a qualified water treatment specialist should be obtained to develop and monitor a treatment program.

⚠ CAUTION

Water must be within design flow limits, clean and treated to ensure proper machine performance and reduce the potential of tubing damage due to corrosion, scaling, erosion, and algae. Carrier assumes no responsibility for chiller or condenser damage resulting from untreated or improperly treated water.

Refrigerant Charging/Adding Charge

IMPORTANT: These units are designed for use with R-134a only. **DO NOT USE ANY OTHER REFRIGERANT** in these units without first consulting your Carrier representative.

⚠ CAUTION

When adding or removing charge, circulate water through the condenser (30HXC) and cooler at all times to prevent freezing. Freezing damage is considered abuse and may void the Carrier warranty.

⚠ CAUTION

DO NOT OVERCHARGE system. Overcharging results in higher discharge pressure with higher cooling fluid consumption, possible compressor damage and higher power consumption.

Indication of low charge on a system:

NOTE: To check for low refrigerant charge on a 30HXC unit, several factors must be considered. A flashing liquid line sight glass (located in the EXV body) is not necessarily an indication of inadequate charge. There are many system conditions where a flashing sight glass occurs under normal operation. The EXV metering device is designed to work properly under these conditions.

1. Make sure that the circuit is running at a full-load condition. To check whether circuit A is fully loaded, enter the Outputs mode from the Navigator and then sub-mode 'CIR.A' or 'CIR.B' depending on the circuit under investigation. The circuit is fully loaded if its compressor and loader relays all show 'On'.
2. It may be necessary to use the Service Test feature to force the circuit into a full-load condition. If this is the case, see the instructions for using the Service Test feature in Table 10 of this manual.
3. With the circuit running at full load, verify that the cooler leaving fluid temperature is in the range of 38 to 46 F (3.3 to 7.8 C). Check temperature drop across liquid line strainer/drier. Maximum allowable temperature drop is 3° F (1.7° C). Strainer is cleanable if necessary and contains 1 standard drier core on all 30HXA,C 161-271 models.
4. At this condition, observe the refrigerant in the liquid line sight glass. If there is a clear sight glass, and no signs of flashing, then the circuit is adequately charged. Skip the remaining steps.
5. If the refrigerant appears to be flashing, the circuit is probably low on charge. Verify this by checking the EXV Percent Open. This information is located under the sub-mode 'CIR.A' or 'CIR.B' (Outputs mode) and is shown as items 'EXV.A' and 'EXV.B' Scroll through the Navigator until the desired item is located.
6. If the EXV Percent Open is greater than 60%, and the liquid line sight glass is flashing, then the circuit is low on charge. Follow the procedure for adding charge for 30HXC units.

To add charge to the 30HXC systems:

1. Make sure that the unit is running at full load, and that the cooler leaving fluid temperature is in the range of 42 to 46 F (5.6 to 7.8 C).
2. At these operating conditions, check the liquid line sight glass. If there is a clear sight glass, then the unit has sufficient charge. If the sight glass is flashing, then check the EXV Percent Open. If this is greater than 60%, then begin adding charge.

NOTE: A flashing liquid line sight glass at operating conditions other than those mentioned above is not necessarily an indication of low refrigerant charge.

3. Add 5 lb (2.3 kg) of liquid charge into the cooler using the fitting located on the tube entering the bottom of the cooler. This fitting is located between the electronic expansion valve (EXV) and the cooler.
4. Observe the EXV Percent Open value. The EXV should begin closing as charge is being added. Allow the unit to stabilize. If the EXV Percent Open remains above 60%, and the sight glass continues flashing, add an additional 5 lb (2.3 kg) of liquid charge.
5. Allow the unit to stabilize, and again check the EXV Percent Open. Continue adding 5 lb (2.3 kg) at a time of liquid refrigerant charge, and allow the unit to stabilize before checking the EXV position.
6. When the EXV Percent Open is in the range of 40 to 60%, check the liquid line sight glass. Slowly add enough

additional liquid charge to ensure a clear sight glass. This should be done slowly to avoid overcharging the unit.

7. Verify adequate charge by continuing to run at full load with 42 to 46 F (5.6 to 7.8 C) cooler leaving fluid temperature. Check that the refrigerant is not flashing in the liquid-line sight glass. The EXV Percent Open should be between 40 and 60%.

To add charge to the 30HXA systems:

1. Make sure that the circuit is running at a full load condition and all condenser fans are energized and running on the keypad, at the appropriate line on the display. To check whether circuit A is fully loaded, enter the Outputs mode from the Navigator and then sub-mode 'CIR.A' or 'CIR.B' depending on the circuit under investigation. The circuit is fully loaded if its compressor and loader relays all show 'On'.
2. It may be necessary to use the Service Test feature to force the circuit into a full-load condition. If this is the case, see the instructions for using the Service Test feature in Table 10 of this manual.
3. With the circuit running at full-load, verify that the cooler leaving fluid temperature is in the range of 38 to 48 F (5.6 to 7.8 C).
4. For 30HXA chillers, raise the compressor discharge to approximately 125 F (51.7 C) saturated condensing temperature (185 psig [1276 kPa]). Measure the liquid temperature entering the EXV. The liquid temperature should be approximately 107 F (41.7 C) for optimum charge. If the temperature is greater than 107 F (41.7 C) and the sight glass is flashing, the circuit is undercharged.
5. Add 5 lb (2.3 kg) of liquid charge into the cooler using the fitting located on the tube entering the bottom of the cooler. This fitting is located between the Electronic Expansion Valve (EXV) and the cooler.
6. Allow the system to stabilize and then recheck the liquid temperature. Repeat Step 5 as needed allowing the system to stabilize between each charge addition. Slowly add charge as the sight glass begins to clear to avoid overcharging.

Oil Charging/Low Oil Recharging

OIL SPECIFICATION — If oil is added, it must meet the following Carrier specifications:

- Emkarate. RL220XL
- Oil type Inhibited polyolester-based synthetic compressor lubricant for use in screw compressors.
- ISO Viscosity Grade 220

This oil is available in the following quantities from your local Carrier representative (see Table 33).

Table 33 — Available Oil Quantities and Part Numbers

QUANTITY	TOTALINE PART NUMBER	RCD PART NUMBER
1 Quart	P903-1225	—
1 Gallon	P903-1201	PP23BZ104-001
5 Gallons	P903-1205	PP23BZ104-005

Addition of oil charge to 30HX systems:

1. If the 30HX unit shuts off repeatedly on Low Oil Level (Alert number 124 or 125), this may be an indication of inadequate oil charge. It could also mean simply that oil is in the process of being reclaimed from the low-side of the system.
2. Begin by running the unit at full load for 1½ hours. Use the Manual Control feature of the software if the unit does not normally run at full load.

3. After running the unit for 1½ hours, allow the unit to restart and run normally. If the Low Oil Level alarms persist, continue following this procedure.
4. Close the liquid line service valve, and place a pressure gage on top of the cooler. Enable the Service Test feature using the Navigator and turn the EOR switch to Enable. Start the desired compressor by turning it On under the 'COMP' sub-mode. Select item 'CC.A1' for compressor A1, 'CC.B1' for compressor B1, etc.
5. Before starting the compressor, the unit will go through its normal pre-lube pump routine. If there is an insufficient level of oil in the oil separator, the compressor will not start, and a pre-start oil pressure alarm will be posted. Skip to Step 8.
6. If the compressor starts successfully, observe the cooler pressure gage. When this gage reads approximately 10 psig, turn the selected compressor Off from the Navigator™ module and move the EOR switch to the Off position.
7. Open the liquid line service valve and allow the unit to restart and run normally. If the Low Oil Level alarms persist, continue following this procedure.
8. If none of the previous steps were successful, the unit is low on oil charge. Add oil to the oil separator using the ¼-in. Schrader-type fitting on the discharge line entering the top of the oil separator.

CAUTION

Do not add oil at any other location as improper unit operation may result.

9. Make sure that the unit is not running when adding oil, as this will make the oil charging process easier. Because the system is under pressure even when the unit is not running, it will be necessary to use a suitable pump (hand pump or electric pump) to add oil to the system.
10. Using a suitable pump, add ½ gal. (1.89 L) of Emkarate RL220XL Polyolester oil (absolutely no substitutes are approved) to the system. Make sure that the oil level safety switch is NOT jumpered, and allow the unit to restart and run normally. Do not exceed maximum oil change. See Table 34.

Table 34 — Factory Oil Charges

UNIT SIZE	CIRCUIT A (gal)	CIRCUIT A (L)	CIRCUIT B (gal)	CIRCUIT B (L)
30HXA076-186	5.0	18.9	5.0	18.9
30HXC076-186	4.5	17.0	4.5	17.0
30HXA206-271	8.0	30.2	5.0	18.9
30HXC206-271	7.5	28.4	5.0	18.9

11. If low oil level problems persist, add another 1.89 L (½ gal.) of oil. Continue adding oil in 1.89 L (½ gal.) increments until the problem is resolved. If it is necessary to add more than 5.75 L (1.5 gallons) of oil to the system, contact your Carrier representative.

Oil Filter Maintenance — Each compressor has its own internal oil filter and each circuit also has an in-line external filter. The internal oil filter pressure drop should be checked and filter changed (if necessary) after the initial 200 to 300 hours of compressor operation. Oil line pressure loss is monitored by the control and reported for each compressor as the oil filter pressure drop. This information can be found in the Pressures mode of the Navigator for each circuit. The 'PRC.A' sub-mode contains oil filter pressure differentials for each Circuit A compressor (items 'FD.A1' 'FD.A2'). Similarly, the PRC.B sub-mode contains oil filter pressure differentials for

each circuit B compressor (item FD.B1). This pressure differential (discharge pressure minus oil pressure, both from pressure transducer inputs) is typically 15 to 20 psi (103 to 138 kPa) for a system with clean internal and external filters. To determine the oil pressure drop due to the oil lines and external filter only, connect a gage to the oil pressure bleed port. Compare this value to the discharge pressure read at the Navigator module. If this value exceeds 10 psi (69 kPa), replace the external filter. The difference between the gauge pressure and compressor oil pressure read at the Navigator module is the pressure drop through the internal oil filter. Replace the internal oil filter if the pressure drop is greater than 25 psi (173 kPa) for 30HXC and 30 psi (207 kPa) for 30HXA chillers.

REPLACING THE EXTERNAL OIL FILTER

CAUTION

Compressor oil is pressurized. Use proper safety precautions when relieving pressure.

Fully front seat (close) the angle valve on the filter and the ball valve at the compressor. Connect a charging hose to the oil pressure bleed port and drain the oil trapped between service valves. A quart (liter) of oil is typically what is removed during this process. Remove the charging hose.

Unscrew the nut from the other side of the filter and remove the old filter. Remove protective plastic caps from new filter and install. Draw a vacuum at the bleed port. Remove charging hose. Open angle valve enough to let oil flow. Check both fittings for leaks and repair if necessary. Backseat angle valve and open ball valve.

REPLACING THE INTERNAL OIL FILTER — Close the service valves at the compressor and drain the oil using the bleed port. If the oil pressure does not bleed off using this method it will be necessary to remove the entire circuit charge. Using a ¾-in. Allen wrench, remove the internal filter access cover (see Fig. 24). Remove the old filter. Replacement filters (one for each compressor) are factory supplied to cover the first changeout. After that, filters are field supplied. Lightly oil O-ring in the filter and install with filter open end first into the housing. Replace access cover and retorque to 75 ft-lb (101 N-m). Follow procedure in previous section for opening angle valve and purging lines. Check for leaks and repair if necessary.

Compressor Changeout Sequence — Compressor service requires metric tools and hardware. Change compressors according to the following procedure:

1. Turn off all main and control circuit power supplying the machine.
2. Close the discharge and liquid valve(s), suction valve (if equipped), and cooler inlet line service valve (if equipped), oil line shutoff valve, and minimum load shutoff valve (if equipped) for circuit to be changed. Disconnect the oil inlet line from the compressor. Disconnect oil filter with fitting at shutoff valve side and set filter and compressor inlet line assembly aside.
3. Remove any remaining refrigerant in the compressor and refrigerant lines using proper reclaiming techniques. All of the refrigerant that is in the cooler must be removed if there is no suction service valve installed on the cooler.

IMPORTANT: Cooler and condenser pumps must be energized. Fluid must be flowing through heat exchangers whenever adding or removing charge.

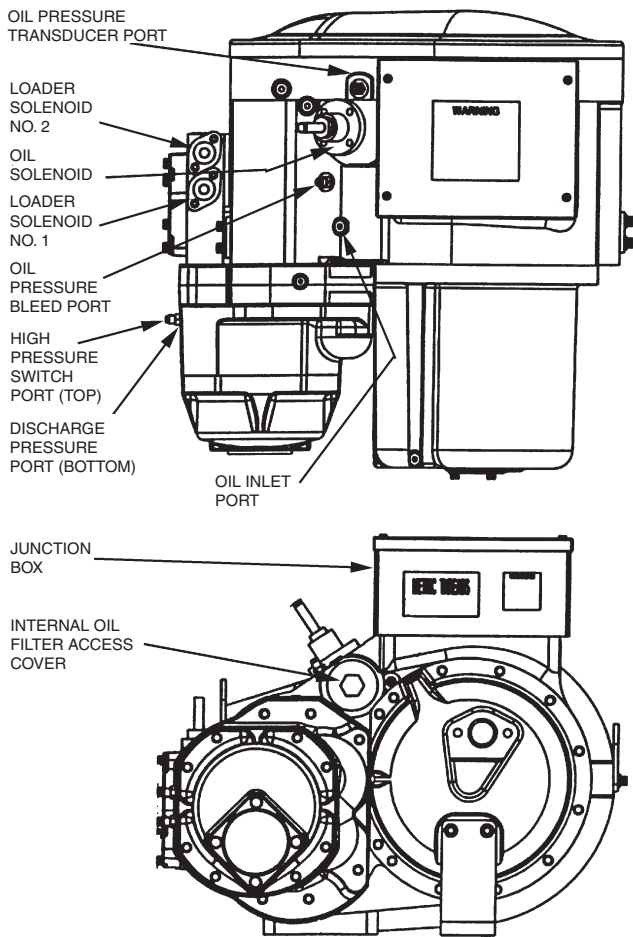

Fig. 24 — Compressor Component Diagram

4. Remove junction box cover of compressor to be changed. Check main power leads for marked numbers. If no numbers are visible on leads, mark leads with appropriate numbers to match those printed on the ends of the terminal lugs. **This is extremely important as power leads MUST be installed on the exact terminals from which they were removed.**

5. Disconnect main power leads from compressor terminal lugs. Mark remaining control circuit wires (connected together with wire nuts) for ease of reconnecting later. The following color scheme applies (verify with label diagram on panel):

Loader 1	2 Violet wires
Loader 2	2 Pink wires
Motor Cooling Solenoid	1 Blue wire, 1 Brown wire *
Oil Solenoid	1 Orange wire, 1 Brown wire*
High-Pressure Switch	2 Red wires

*One lead from the motor cooling and oil solenoids are connected together with a single brown wire.

6. Remove loader (mark solenoids no. 1 and 2 for replacement) and oil solenoids and high-pressure switch from compressor. Using 2 wrenches, carefully remove the oil pressure transducer from the compressor. These will all be reconnected to the replacement compressor.

NOTE: Some oil will leak out of the transducer fitting when the transducer is removed. See Fig. 24.

7. Mark motor temperature leads (2 blue wires) and remove from quick connect terminals in the junction box.

CAUTION

The next steps involve compressor unbolting and removal. Compressor seals are made using O-rings. Use care when removing bolts and disconnecting flanges. The O-rings must NOT be re-used. New O-rings are provided with the replacement compressor. **The 06N screw compressors weigh approximately 920 lb (417 kg).** Be sure that an appropriate lifting cart or hoist is used to avoid injury. See Fig. 25 for lifting locations and center of gravity dimensions. Make sure compressor is properly rigged before unbolting.

LIFTING LUGS BOTH OUTSIDE EDGES EQUIDISTANT FROM GEAR COVER END

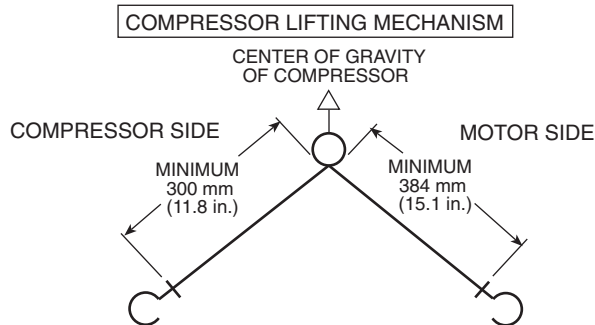

NOTE: Locate strap from center of gravity lifting ring and support motor casing to provide 3-point level rigging.

Fig. 25 — Compressor Lifting Diagrams

8. Remove the 2 bolts securing the motor cooling/economizer line flange to the compressor.
9. Remove the four M14 bolts securing the discharge line flange to the compressor. Two of the bolts also secure the mounting bracket for the external oil filter. Support the oil line to prevent damage to the line while the compressor is being changed.
10. Move lifting apparatus into place and attach to the 2 lifting rings on the compressor. Apply minimal tension to hold the compressor while the remaining bolts are removed.
11. Remove the $\frac{3}{8}$ -in. holddown bolt securing the foot at the discharge end of the compressor to the mounting bracket on the cooler. A foot bracket will be mounted to the replacement compressor.
12. Remove the 4 lockwashers and nuts securing the compressor to the suction flange of the cooler. The compressor is held in place using four M14 x 2 studs through the suction nozzle of the cooler. The studs have an E-12 external Torx drive head. If possible, remove studs; if studs hit the cooler insulation, leave them in place — they will not interfere with compressor removal or installation. Save all the hardware as it will be needed to install the replacement compressor.
13. After checking to ensure all lines, wires, conduits, etc. are free and out of the way, remove compressor from cooler. Apply a light film of O-ring grease to new O-ring and place back into groove in mounting flange of compressor. If the new compressor is the A1/A2 (30HX units) compressor, remove the compressor junction box and rotate it 180 degrees. Tighten screws to 6.8 to 9.5 N-m (5 to 7 ft-lb). The A1 and A2 compressors are on the right side of the unit when facing the unit control box.
14. Remove suction cover plate and bolts from new compressor and set compressor on unit flange. Thread the studs all

the way back into the compressor. Install the 4 lock washers and nuts finger-tight. Tighten bolts in a crossing pattern to a range of 81.4 to 135.6 N-m (60 to 100 ft-lb). Do NOT overtighten as damage may result to O-ring. Install and tighten hold-down bolt in mounting foot.

15. Remove motor cooling/economizer and discharge line cover plates from new compressor.
16. Apply a light film of O-ring grease to motor cooling/economizer and discharge line O-rings, place back into grooves and install flange bolts. Tighten discharge line bolts in a crossing pattern to a range of 81.4 to 135.6 N-m (60 to 100 ft-lb). Tighten motor cooling/economizer bolts to a range of 81.4 to 108.5 N-m (60 to 80 ft-lb). Do NOT overtighten as damage may result to O-rings.
17. Reconnect the oil filter to the shutoff valve and oil line to the compressor. Install oil line straight into fitting until ferrule seats against fitting. Thread packing nut onto fitting and tighten finger tight. Use a backup wrench to finish tightening the nut. Do not overtighten.
18. Reinstall the loader and oil solenoids, high-pressure switch, and oil pressure transducer. Make sure the loader solenoids are installed on the correct number loader.
19. Reconnect conduits back into compressor junction box. Reconnect all wiring that was removed in Steps 4, 5, and 7. Temporarily install the reverse rotation low pressure switch that is supplied with the replacement compressor. Connect the switch to the second high pressure port using a standard 1/4-in. service hose. The switch will not reset until 10 psig of pressure is present on the switch. Temporarily wire the reverse rotation low pressure switch in series with the compressor's high pressure switch as shown in Fig. 26.

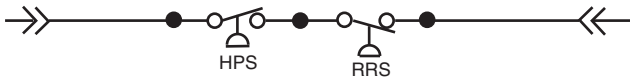

LEGEND

- HPS — High-Pressure Switch
- RRS — Reverse Rotation Switch (HK01CB002)

Fig. 26 — Reverse Rotation Switch Wiring

20. Leak check compressor and refrigerant lines with nitrogen. Repair any leaks found. Remove nitrogen from system. Evacuate compressor and refrigerant lines. Refer to the Refrigerant Charging/Adding Charge and Oil Charging/Low Oil Recharging sections on pages 51 and 52 for recharging procedures.
21. Open all shutoff valves and leak check the circuit and all fittings and joints. Repair any leaks found.
22. Reset the reverse rotation low pressure switch.
23. Restore main and control power to the machine. Put the Enable/Off/Remote Contact switch in the Enable position. Using the Navigator under the Service Test mode, turn the TEST sub-mode 'On'. Under the OUTS sub-mode, test each compressor's oil and motor cooling solenoids (items 'MC.A1', 'OS.A1', etc.). Next, locate and test each loader solenoid under the COMP sub-mode (items 'LD.A1', etc.). It is important that the loaders are located properly (loader 1 on right hand side when viewed from side opposite control box on 30HXA,HXC units).
24. Locate the appropriate compressor item ('CC.A1', etc.) under the COMP sub-mode and start the compressor. Press , followed by to change the value to On, and then again. Once the compressor has successfully started, energize both loaders one at a time. Let the circuit stabilize with both loaders energized. Refer to the

Refrigerant Charging/Adding Charge and Oil Charging/Low Oil Recharging sections of this document for recharging procedures and performance criteria.

25. Once proper rotation has been verified, disconnect and lock out the power to the chiller. The reverse rotation low pressure switch can now be removed from the compressor and high pressure switch circuit.

BURNOUT CLEAN-UP PROCEDURE — If a screw compressor motor burns out on a 30HX chiller, a simple cleanup should be performed. The following procedure provides the minimum steps to be taken before restarting the circuit.

1. Remove the oil from the oil separator. This can be facilitated by connecting a hose to the port located on the service valve entering the external oil filter. Run the hose to a container(s) that can hold up to 5 to 6 gallons (19 to 20 L) of oil. Pressurize the circuit to force out most of the oil in the separator. To remove the remaining oil, the pre-lube pump can be run in the Service Test mode from the Navigator. Enable the desired pump (either item 'OL.P.A' or 'OL.P.B' in the OUTS sub-mode). To prevent wear to the pump components, do not allow the pre-lube pump to operate "dry."
2. Remove the failed compressor following the Compressor Changeout Sequence procedure on page 53.
3. Once the compressor is removed access the oil catch pan through the cooler-compressor mounting flange. Clean out any debris which may have collected in the oil catch pan.
4. Install a new compressor.
5. To dilute and remove any residual oil left in the separator, pump approximately 1/2 gallon (2 L) of compressor oil into the oil separator using the Schrader port located on the discharge line and remove using the pre-lube pump described in Step 1.
6. Disconnect the hose from the external oil filter service valve.
7. Install a new filter drier core and compressor external oil filter. If desired, a burnout (activated carbon) core may be used, but should be replaced with a standard filter drier core during the next filter replacement.
8. Measure in the amount of Emkarate RL220XL Polyolester oil as specified on the nameplate of the chiller.
9. Leak check, evacuate and recharge the machine as described in this manual with the amount of R-134a stated on the chiller nameplate.
10. Perform periodic acid checks on the circuit and change the filter drier core in the liquid line as necessary. Use the Carrier Standard Service Techniques Manual as a source of reference.

Moisture-Liquid Indicator — Clear flow of liquid refrigerant indicates sufficient charge in the system. Note, however, that bubbles in the sight glass do not necessarily indicate insufficient charge. Moisture in the system is measured in parts per million (ppm), changes of color of indicator are:

- Green — moisture is below 80 ppm;
- Yellow-green (chartreuse) — 80 to 225 ppm (caution);
- Yellow (wet) — above 225 ppm.

Change filter drier at the first sign of moisture in the system.

IMPORTANT: Unit must be in operation for at least 12 hours before moisture indicator can give an accurate reading. With the unit running, the indicating element must be in contact with liquid refrigerant to give true reading.

Filter Drier — Whenever moisture-liquid indicator shows presence of moisture, replace filter drier core. Refer to Carrier Standards Service Technique Manual, Chapter 1, Refrigerants, for details on servicing filter driers. Cleanable strainers have been installed in each circuit's liquid line to aid in removal of system contaminants and debris. There is one industry standard drier core in each strainer. See Fig. 27.

Liquid Line Service Valve — This valve provides a 1/4-in. Schrader connection for field charging. In combination with compressor discharge service valve, each circuit can be pumped down into the high side for servicing.

Thermistors — To aid in verifying thermistor performance, resistances at various temperatures are listed for all thermistors (except motor thermistors) in Tables 35A-36B. See Table 37 for motor thermistor values.

LOCATION — General location of thermistor sensors and terminal connections in the control box are listed in Table 3.

THERMISTOR REPLACEMENT

⚠ CAUTION

All thermistors are installed in wells and will slide out of the wells easily. The wells are under refrigerant pressure (cooler EWT and LWT are under waterside pressure) and do not need to be removed to replace a faulty thermistor.

To Replace Thermistors T1, T2, T3, T4, T5, or T6 (Entering, Leaving Water, Discharge Gas Temperature) — Disconnect appropriate connector from the Main Base Board (MBB). Thermistors T1 and T2 are connected to MBB-J8 and thermistors T3 through T6 are connected to EXV-J5. These six thermistors use insulation displacement connectors. New thermistors should be spliced to existing wiring close to the connector unless new connectors are required. A special AMP crimping tool, part no. 58580-1, is needed if new connectors are used. Remove thermistor cable from harness. Remove and discard original thermistor from well. Insert new thermistor in well body to its full depth. Add a small amount of thermal conductive grease to thermistor probe and well. Thermistors are friction-fit thermistors and will slip back into well located at the cooler head (T1, T2) or at the top of each compressor discharge line (T3 through T6). Secure thermistor to well body with a wire tie to prevent thermistor from working its way out of the well. See Fig. 28.

To Service Compressor Motor Thermistors — Two thermistors are factory installed in each compressor. Connections for the thermistors are located in the compressor junction box. There are 3 terminals for the thermistors: S1, S2, and C. Motor temperature is measured by leads connected to one of the S terminals and the C terminal. If a compressor motor thermistor failure occurs, verify that there is a true short or open circuit at these terminals. If one of the thermistors fails, disconnect and relocate the wire on one of the S terminals to the other S terminal (S1 to S2 or S2 to S1). The thermistors are not serviceable in the field. If both of the compressor motor thermistors fail, compressor replacement is required. See Table 37 for motor thermistor temperature and resistance values.

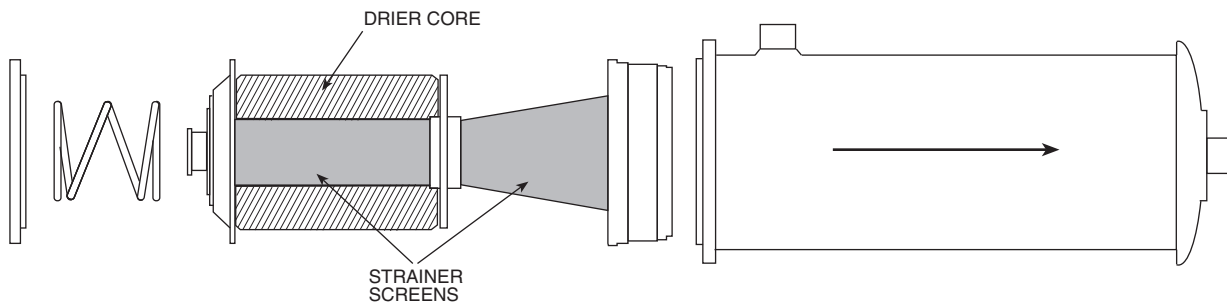

Fig. 27 — Filter Drier

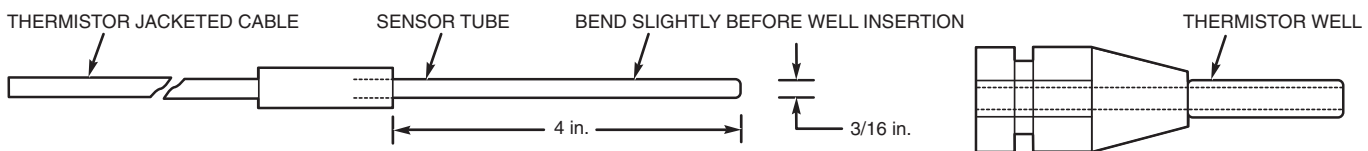

Fig. 28 — Thermistor Replacement (T1 through T6)

Table 35A — 5K Thermistor Temperature (°F) vs Resistance/Voltage

TEMP (F)	VOLTAGE DROP (V)	RESISTANCE (Ohms)	TEMP (F)	VOLTAGE DROP (V)	RESISTANCE (Ohms)	TEMP (F)	VOLTAGE DROP (V)	RESISTANCE (Ohms)
-25	3.699	98,010	59	1.982	7,686	143	0.511	1,190
-24	3.689	94,707	60	1.956	7,665	144	0.502	1,165
-23	3.679	91,522	61	1.930	7,468	145	0.494	1,141
-22	3.668	88,449	62	1.905	7,277	146	0.485	1,118
-21	3.658	85,486	63	1.879	7,091	147	0.477	1,095
-20	3.647	82,627	64	1.854	6,911	148	0.469	1,072
-19	3.636	79,871	65	1.829	6,735	149	0.461	1,050
-18	3.624	77,212	66	1.804	6,564	150	0.453	1,029
-17	3.613	74,648	67	1.779	6,399	151	0.445	1,007
-16	3.601	72,175	68	1.754	6,238	152	0.438	986
-15	3.588	69,790	69	1.729	6,081	153	0.430	965
-14	3.576	67,490	70	1.705	5,929	154	0.423	945
-13	3.563	65,272	71	1.681	5,781	155	0.416	925
-12	3.550	63,133	72	1.656	5,637	156	0.408	906
-11	3.536	61,070	73	1.632	5,497	157	0.402	887
-10	3.523	59,081	74	1.609	5,361	158	0.395	868
-9	3.509	57,162	75	1.585	5,229	159	0.388	850
-8	3.494	55,311	76	1.562	5,101	160	0.381	832
-7	3.480	53,526	77	1.538	4,976	161	0.375	815
-6	3.465	51,804	78	1.516	4,855	162	0.369	798
-5	3.450	50,143	79	1.493	4,737	163	0.362	782
-4	3.434	48,541	80	1.470	4,622	164	0.356	765
-3	3.418	46,996	81	1.448	4,511	165	0.350	750
-2	3.402	45,505	82	1.426	4,403	166	0.344	734
-1	3.386	44,066	83	1.404	4,298	167	0.339	719
0	3.369	42,679	84	1.382	4,196	168	0.333	705
1	3.352	41,339	85	1.361	4,096	169	0.327	690
2	3.335	40,047	86	1.340	4,000	170	0.322	677
3	3.317	38,800	87	1.319	3,906	171	0.317	663
4	3.299	37,596	88	1.298	3,814	172	0.311	650
5	3.281	36,435	89	1.278	3,726	173	0.306	638
6	3.262	35,313	90	1.257	3,640	174	0.301	626
7	3.243	34,231	91	1.237	3,556	175	0.296	614
8	3.224	33,185	92	1.217	3,474	176	0.291	602
9	3.205	32,176	93	1.198	3,395	177	0.286	591
10	3.185	31,202	94	1.179	3,318	178	0.282	581
11	3.165	30,260	95	1.160	3,243	179	0.277	570
12	3.145	29,351	96	1.141	3,170	180	0.272	561
13	3.124	28,473	97	1.122	3,099	181	0.268	551
14	3.103	27,624	98	1.104	3,031	182	0.264	542
15	3.082	26,804	99	1.086	2,964	183	0.259	533
16	3.060	26,011	100	1.068	2,898	184	0.255	524
17	3.038	25,245	101	1.051	2,835	185	0.251	516
18	3.016	24,505	102	1.033	2,773	186	0.247	508
19	2.994	23,789	103	1.016	2,713	187	0.243	501
20	2.972	23,096	104	0.999	2,655	188	0.239	494
21	2.949	22,427	105	0.983	2,597	189	0.235	487
22	2.926	21,779	106	0.966	2,542	190	0.231	480
23	2.903	21,153	107	0.950	2,488	191	0.228	473
24	2.879	20,547	108	0.934	2,436	192	0.224	467
25	2.856	19,960	109	0.918	2,385	193	0.220	461
26	2.832	19,393	110	0.903	2,335	194	0.217	456
27	2.808	18,843	111	0.888	2,286	195	0.213	450
28	2.784	18,311	112	0.873	2,239	196	0.210	445
29	2.759	17,796	113	0.858	2,192	197	0.206	439
30	2.735	17,297	114	0.843	2,147	198	0.203	434
31	2.710	16,814	115	0.829	2,103	199	0.200	429
32	2.685	16,346	116	0.815	2,060	200	0.197	424
33	2.660	15,892	117	0.801	2,018	201	0.194	419
34	2.634	15,453	118	0.787	1,977	202	0.191	415
35	2.609	15,027	119	0.774	1,937	203	0.188	410
36	2.583	14,614	120	0.761	1,898	204	0.185	405
37	2.558	14,214	121	0.748	1,860	205	0.182	401
38	2.532	13,826	122	0.735	1,822	206	0.179	396
39	2.506	13,449	123	0.723	1,786	207	0.176	391
40	2.480	13,084	124	0.710	1,750	208	0.173	386
41	2.454	12,730	125	0.698	1,715	209	0.171	382
42	2.428	12,387	126	0.686	1,680	210	0.168	377
43	2.402	12,053	127	0.674	1,647	211	0.165	372
44	2.376	11,730	128	0.663	1,614	212	0.163	367
45	2.349	11,416	129	0.651	1,582	213	0.160	361
46	2.323	11,112	130	0.640	1,550	214	0.158	356
47	2.296	10,816	131	0.629	1,519	215	0.155	350
48	2.270	10,529	132	0.618	1,489	216	0.153	344
49	2.244	10,250	133	0.608	1,459	217	0.151	338
50	2.217	9,979	134	0.597	1,430	218	0.148	332
51	2.191	9,717	135	0.587	1,401	219	0.146	325
52	2.165	9,461	136	0.577	1,373	220	0.144	318
53	2.138	9,213	137	0.567	1,345	221	0.142	311
54	2.112	8,973	138	0.557	1,318	222	0.140	304
55	2.086	8,739	139	0.548	1,291	223	0.138	297
56	2.060	8,511	140	0.538	1,265	224	0.135	289
57	2.034	8,291	141	0.529	1,240	225	0.133	282
58	2.008	8,076	142	0.520	1,214			

Table 35B — 5K Thermistor Temperature (°C) vs Resistance/Voltage

TEMP (C)	VOLTAGE DROP (V)	RESISTANCE (Ohms)	TEMP (C)	VOLTAGE DROP (V)	RESISTANCE (Ohms)	TEMP (C)	VOLTAGE DROP (V)	RESISTANCE (Ohms)
-32	3.705	100,260	15	1.982	7,855	62	0.506	1,158
-31	3.687	94,165	16	1.935	7,499	63	0.490	1,118
-30	3.668	88,480	17	1.889	7,161	64	0.475	1,079
-29	3.649	83,170	18	1.844	6,840	65	0.461	1,041
-28	3.629	78,125	19	1.799	6,536	66	0.447	1,006
-27	3.608	73,580	20	1.754	6,246	67	0.433	971
-26	3.586	69,250	21	1.710	5,971	68	0.420	938
-25	3.563	65,205	22	1.666	5,710	69	0.407	906
-24	3.539	61,420	23	1.623	5,461	70	0.395	876
-23	3.514	57,875	24	1.580	5,225	71	0.383	836
-22	3.489	54,555	25	1.538	5,000	72	0.371	805
-21	3.462	51,450	26	1.497	4,786	73	0.360	775
-20	3.434	48,536	27	1.457	4,583	74	0.349	747
-19	3.406	45,807	28	1.417	4,389	75	0.339	719
-18	3.376	43,247	29	1.378	4,204	76	0.329	693
-17	3.345	40,845	30	1.340	4,028	77	0.319	669
-16	3.313	38,592	31	1.302	3,861	78	0.309	645
-15	3.281	36,476	32	1.265	3,701	79	0.300	623
-14	3.247	34,489	33	1.229	3,549	80	0.291	602
-13	3.212	32,621	34	1.194	3,404	81	0.283	583
-12	3.177	30,866	35	1.160	3,266	82	0.274	564
-11	3.140	29,216	36	1.126	3,134	83	0.266	547
-10	3.103	27,633	37	1.093	3,008	84	0.258	531
-9	3.065	26,202	38	1.061	2,888	85	0.251	516
-8	3.025	24,827	39	1.030	2,773	86	0.244	502
-7	2.985	23,532	40	0.999	2,663	87	0.237	489
-6	2.945	22,313	41	0.969	2,559	88	0.230	477
-5	2.903	21,163	42	0.940	2,459	89	0.223	466
-4	2.860	20,079	43	0.912	2,363	90	0.217	456
-3	2.817	19,058	44	0.885	2,272	91	0.211	446
-2	2.774	18,094	45	0.858	2,184	92	0.204	436
-1	2.730	17,184	46	0.832	2,101	93	0.199	427
0	2.685	16,325	47	0.807	2,021	94	0.193	419
1	2.639	15,515	48	0.782	1,944	95	0.188	410
2	2.593	14,749	49	0.758	1,871	96	0.182	402
3	2.547	14,026	50	0.735	1,801	97	0.177	393
4	2.500	13,342	51	0.713	1,734	98	0.172	385
5	2.454	12,696	52	0.691	1,670	99	0.168	376
6	2.407	12,085	53	0.669	1,609	100	0.163	367
7	2.360	11,506	54	0.649	1,550	101	0.158	357
8	2.312	10,959	55	0.629	1,493	102	0.154	346
9	2.265	10,441	56	0.610	1,439	103	0.150	335
10	2.217	9,949	57	0.591	1,387	104	0.146	324
11	2.170	9,485	58	0.573	1,337	105	0.142	312
12	2.123	9,044	59	0.555	1,290	106	0.138	299
13	2.076	8,627	60	0.538	1,244	107	0.134	285
14	2.029	8,231	61	0.522	1,200			

**Table 36A — 10K Thermistor Temperatures (°F) vs Resistance/Voltage Drop
(For Thermistor T10)**

TEMP (F)	VOLTAGE DROP (V)	RESISTANCE (Ohms)	TEMP (F)	VOLTAGE DROP (V)	RESISTANCE (Ohms)	TEMP (F)	VOLTAGE DROP (V)	RESISTANCE (Ohms)
-25	4.758	196,453	61	2.994	14,925	147	0.890	2,166
-24	4.750	189,692	62	2.963	14,549	148	0.876	2,124
-23	4.741	183,300	63	2.932	14,180	149	0.862	2,083
-22	4.733	177,000	64	2.901	13,824	150	0.848	2,043
-21	4.724	171,079	65	2.870	13,478	151	0.835	2,003
-20	4.715	165,238	66	2.839	13,139	152	0.821	1,966
-19	4.705	159,717	67	2.808	12,814	153	0.808	1,928
-18	4.696	154,344	68	2.777	12,493	154	0.795	1,891
-17	4.686	149,194	69	2.746	12,187	155	0.782	1,855
-16	4.676	144,250	70	2.715	11,884	156	0.770	1,820
-15	4.665	139,443	71	2.684	11,593	157	0.758	1,786
-14	4.655	134,891	72	2.653	11,308	158	0.745	1,752
-13	4.644	130,402	73	2.622	11,031	159	0.733	1,719
-12	4.633	126,183	74	2.592	10,764	160	0.722	1,687
-11	4.621	122,018	75	2.561	10,501	161	0.710	1,656
-10	4.609	118,076	76	2.530	10,249	162	0.699	1,625
-9	4.597	114,236	77	2.500	10,000	163	0.687	1,594
-8	4.585	110,549	78	2.470	9,762	164	0.676	1,565
-7	4.572	107,006	79	2.439	9,526	165	0.666	1,536
-6	4.560	103,558	80	2.409	9,300	166	0.655	1,508
-5	4.546	100,287	81	2.379	9,078	167	0.645	1,480
-4	4.533	97,060	82	2.349	8,862	168	0.634	1,453
-3	4.519	94,020	83	2.319	8,653	169	0.624	1,426
-2	4.505	91,019	84	2.290	8,448	170	0.614	1,400
-1	4.490	88,171	85	2.260	8,251	171	0.604	1,375
0	4.476	85,396	86	2.231	8,056	172	0.595	1,350
1	4.461	82,729	87	2.202	7,869	173	0.585	1,326
2	4.445	80,162	88	2.173	7,685	174	0.576	1,302
3	4.429	77,662	89	2.144	7,507	175	0.567	1,278
4	4.413	75,286	90	2.115	7,333	176	0.558	1,255
5	4.397	72,940	91	2.087	7,165	177	0.549	1,233
6	4.380	70,727	92	2.059	6,999	178	0.540	1,211
7	4.363	68,542	93	2.030	6,838	179	0.532	1,190
8	4.346	66,465	94	2.003	6,683	180	0.523	1,169
9	4.328	64,439	95	1.975	6,530	181	0.515	1,148
10	4.310	62,491	96	1.948	6,383	182	0.507	1,128
11	4.292	60,612	97	1.921	6,238	183	0.499	1,108
12	4.273	58,781	98	1.894	6,098	184	0.491	1,089
13	4.254	57,039	99	1.867	5,961	185	0.483	1,070
14	4.235	55,319	100	1.841	5,827	186	0.476	1,052
15	4.215	53,693	101	1.815	5,698	187	0.468	1,033
16	4.195	52,086	102	1.789	5,571	188	0.461	1,016
17	4.174	50,557	103	1.763	5,449	189	0.454	998
18	4.153	49,065	104	1.738	5,327	190	0.447	981
19	4.132	47,627	105	1.713	5,210	191	0.440	964
20	4.111	46,240	106	1.688	5,095	192	0.433	947
21	4.089	44,888	107	1.663	4,984	193	0.426	931
22	4.067	43,598	108	1.639	4,876	194	0.419	915
23	4.044	42,324	109	1.615	4,769	195	0.413	900
24	4.021	41,118	110	1.591	4,666	196	0.407	885
25	3.998	39,926	111	1.567	4,564	197	0.400	870
26	3.975	38,790	112	1.544	4,467	198	0.394	855
27	3.951	37,681	113	1.521	4,370	199	0.388	841
28	3.927	36,610	114	1.498	4,277	200	0.382	827
29	3.903	35,577	115	1.475	4,185	201	0.376	814
30	3.878	34,569	116	1.453	4,096	202	0.370	800
31	3.853	33,606	117	1.431	4,008	203	0.365	787
32	3.828	32,654	118	1.409	3,923	204	0.359	774
33	3.802	31,752	119	1.387	3,840	205	0.354	762
34	3.776	30,860	120	1.366	3,759	206	0.349	749
35	3.750	30,009	121	1.345	3,681	207	0.343	737
36	3.723	29,177	122	1.324	3,603	208	0.338	725
37	3.697	28,373	123	1.304	3,529	209	0.333	714
38	3.670	27,597	124	1.284	3,455	210	0.328	702
39	3.654	26,838	125	1.264	3,383	211	0.323	691
40	3.615	26,113	126	1.244	3,313	212	0.318	680
41	3.587	25,396	127	1.225	3,244	213	0.314	670
42	3.559	24,715	128	1.206	3,178	214	0.309	659
43	3.531	24,042	129	1.187	3,112	215	0.305	649
44	3.503	23,399	130	1.168	3,049	216	0.300	639
45	3.474	22,770	131	1.150	2,986	217	0.296	629
46	3.445	22,161	132	1.132	2,926	218	0.292	620
47	3.416	21,573	133	1.114	2,866	219	0.288	610
48	3.387	20,998	134	1.096	2,809	220	0.284	601
49	3.357	20,447	135	1.079	2,752	221	0.279	592
50	3.328	19,903	136	1.062	2,697	222	0.275	583
51	3.298	19,386	137	1.045	2,643	223	0.272	574
52	3.268	18,874	138	1.028	2,590	224	0.268	566
53	3.238	18,384	139	1.012	2,539	225	0.264	557
54	3.208	17,904	140	0.996	2,488			
55	3.178	17,441	141	0.980	2,439			
56	3.147	16,991	142	0.965	2,391			
57	3.117	16,552	143	0.949	2,343			
58	3.086	16,131	144	0.934	2,297			
59	3.056	15,714	145	0.919	2,253			
60	3.025	15,317	146	0.905	2,209			

**Table 36B — 10K Thermistor Temperatures (°C) vs Resistance/Voltage Drop
(For Thermistor T10)**

TEMP (C)	VOLTAGE DROP (V)	RESISTANCE (Ohms)	TEMP (C)	VOLTAGE DROP (V)	RESISTANCE (Ohms)	TEMP (C)	VOLTAGE DROP (V)	RESISTANCE (Ohms)
-32	4.762	200,510	15	3.056	15,714	62	0.940	2,315
-31	4.748	188,340	16	3.000	15,000	63	0.913	2,235
-30	4.733	177,000	17	2.944	14,323	64	0.887	2,157
-29	4.716	166,342	18	2.889	13,681	65	0.862	2,083
-28	4.700	156,404	19	2.833	13,071	66	0.837	2,011
-27	4.682	147,134	20	2.777	12,493	67	0.813	1,943
-26	4.663	138,482	21	2.721	11,942	68	0.790	1,876
-25	4.644	130,402	22	2.666	11,418	69	0.767	1,813
-24	4.624	122,807	23	2.610	10,921	70	0.745	1,752
-23	4.602	115,710	24	2.555	10,449	71	0.724	1,693
-22	4.580	109,075	25	2.500	10,000	72	0.703	1,637
-21	4.557	102,868	26	2.445	9,571	73	0.683	1,582
-20	4.533	97,060	27	2.391	9,164	74	0.663	1,530
-19	4.508	91,588	28	2.337	8,776	75	0.645	1,480
-18	4.482	86,463	29	2.284	8,407	76	0.626	1,431
-17	4.455	81,662	30	2.231	8,056	77	0.608	1,385
-16	4.426	77,162	31	2.178	7,720	78	0.591	1,340
-15	4.397	72,940	32	2.127	7,401	79	0.574	1,297
-14	4.367	68,957	33	2.075	7,096	80	0.558	1,255
-13	4.335	65,219	34	2.025	6,806	81	0.542	1,215
-12	4.303	61,711	35	1.975	6,530	82	0.527	1,177
-11	4.269	58,415	36	1.926	6,266	83	0.512	1,140
-10	4.235	55,319	37	1.878	6,014	84	0.497	1,104
-9	4.199	52,392	38	1.830	5,774	85	0.483	1,070
-8	4.162	49,640	39	1.784	5,546	86	0.470	1,037
-7	4.124	47,052	40	1.738	5,327	87	0.457	1,005
-6	4.085	44,617	41	1.692	5,117	88	0.444	974
-5	4.044	42,324	42	1.648	4,918	89	0.431	944
-4	4.003	40,153	43	1.605	4,727	90	0.419	915
-3	3.961	38,109	44	1.562	4,544	91	0.408	889
-2	3.917	36,182	45	1.521	4,370	92	0.396	861
-1	3.873	34,367	46	1.480	4,203	93	0.386	836
0	3.828	32,654	47	1.439	4,042	94	0.375	811
1	3.781	31,030	48	1.400	3,889	95	0.365	787
2	3.734	29,498	49	1.362	3,743	96	0.355	764
3	3.686	28,052	50	1.324	3,603	97	0.345	742
4	3.637	26,686	51	1.288	3,469	98	0.336	721
5	3.587	25,396	52	1.252	3,340	99	0.327	700
6	3.537	24,171	53	1.217	3,217	100	0.318	680
7	3.485	23,013	54	1.183	3,099	101	0.310	661
8	3.433	21,918	55	1.150	2,986	102	0.302	643
9	3.381	20,883	56	1.117	2,878	103	0.294	626
10	3.328	19,903	57	1.086	2,774	104	0.287	609
11	3.274	18,972	58	1.055	2,675	105	0.279	592
12	3.220	18,090	59	1.025	2,579	106	0.272	576
13	3.165	17,255	60	0.996	2,488	107	0.265	561
14	3.111	16,474	61	0.968	2,400			

Table 37 — Thermistor Temperature vs Resistance, Motor Temperature Thermistors

TEMP (F)	TEMP (C)	RESISTANCE (Ohms)
-22	-30	88,480.0
-13	-25	65,205.0
-4	-20	48,536.0
5	-15	36,476.0
14	-10	27,663.0
23	-5	21,163.0
32	0	16,325.0
41	5	12,696.0
50	10	9,949.5
59	15	7,855.5
68	20	6,246.0
77	25	5,000.0
86	30	4,028.4
95	35	3,265.7
104	40	2,663.2
113	45	2,184.2
122	50	1,801.2
131	55	1,493.1
140	60	1,243.9
149	65	1,041.4
158	70	875.8
167	75	739.7
176	80	627.6
185	85	534.9
194	90	457.7
203	95	393.3
212	100	339.3
221	105	293.8
230	110	255.3
239	115	222.6
248	120	194.8

NOTE: Motor temperature thermistor values must be verified using resistance. Voltage drop cannot be used.

Pressure Transducers — Discrete high and low pressure transducers are used for pressure sensing on all 30HX chillers. The discharge and oil pressure transducers are high pressure transducers, and the suction and economizer pressure transducers are low pressure transducers (white dot). No pressure transducer calibration is required. The transducers operate on a 5 vdc supply, which is generated by the Main Base Board (MBB) for suction and discharge pressure transducers and by the Compressor Protection Module (CPM) for the oil and economizer pressure transducers. See unit wiring labels for specific MBB and AUX pressure transducer power and signal connections. Refer to Fig. 29A and 29B for pressure transducer locations.

TROUBLESHOOTING — If transducer is suspected of being faulty, first check supply voltage to transducer. Supply voltage should be 5 vdc \pm .2 v. If supply voltage is correct, compare pressure reading displayed on keypad and display module against pressure shown on a calibrated pressure gage. If the 2 pressure readings are not reasonably close, replace pressure transducer. Low pressure transducers suction and economizer pressures should be within \pm 2 psig. Discharge and oil pressures should be within \pm 5 psig.

Chilled Water Flow Sensor — The factory-installed flow sensor is a thermal-dispersion flow switch that requires no field adjustments. See Fig. 30 and 31. The sensor is set for approximately 0.5 ft/sec of flow. The sensor tip houses two thermistors and a heater element. One thermistor is located in the sensor tip, closest to the flowing fluid. This thermistor is used to detect changes in the flow velocity of the liquid. The second thermistor is bonded to the cylindrical wall and is affected only by changes in the temperature of the liquid. The thermistors are positioned to be in close contact with the wall of the sensor probe and, at the same time, to be kept separated from each other within the confines of the probe.

In order to sense flow, it is necessary to heat one of the thermistors in the probe. When power is applied, the tip of the probe is heated. As the fluid starts to flow, heat will be carried

away from the sensor tip. Cooling of the first thermistor is a function of how fast heat is conducted away by the flowing liquid.

The difference in temperature between the two thermistors provides a measurement of fluid velocity past the sensor probe. When fluid velocity is high, more heat will be carried away from the heated thermistor and the temperature differential will be small. As fluid velocity decreases, less heat will be taken from the heated thermistor and there will be an increase in temperature differential.

When unit flow rate is above the minimum flow rate, then the output is switched on, sending 24 vac to the MBB to prove flow has been established.

For recommended maintenance, check the sensor tip for build-up every 6 months. Clean the tip with a soft cloth. If necessary, build-up (e.g., lime) can be removed with a common vinegar cleansing agent.

The flow sensor cable is provided with (3) LEDs that indicate if 24 vac power is present and also status of the switch contacts. The LEDs are as follows:

- Green LED ON – 24 vac present
- One Yellow LED ON – Flow sensor switch OPEN
- Two Yellow LED ON – Flow sensor switch CLOSED

If nuisance trips of the sensor are occurring, follow the steps below to correct the situation:

1. Check to confirm that the factory-installed strainer is clean. Use the blow-down valve provided or remove the screen and clean it. For the case of VFD controlled pumps, ensure that the minimum speed setting has not been changed.
2. Measure the pressure drop across the cooler and using Appendix D on pages 81-82, calculate the cooler flow rate and compare this to the requirements.
3. Verify that cable connections at the switch and at the terminal block are secure.

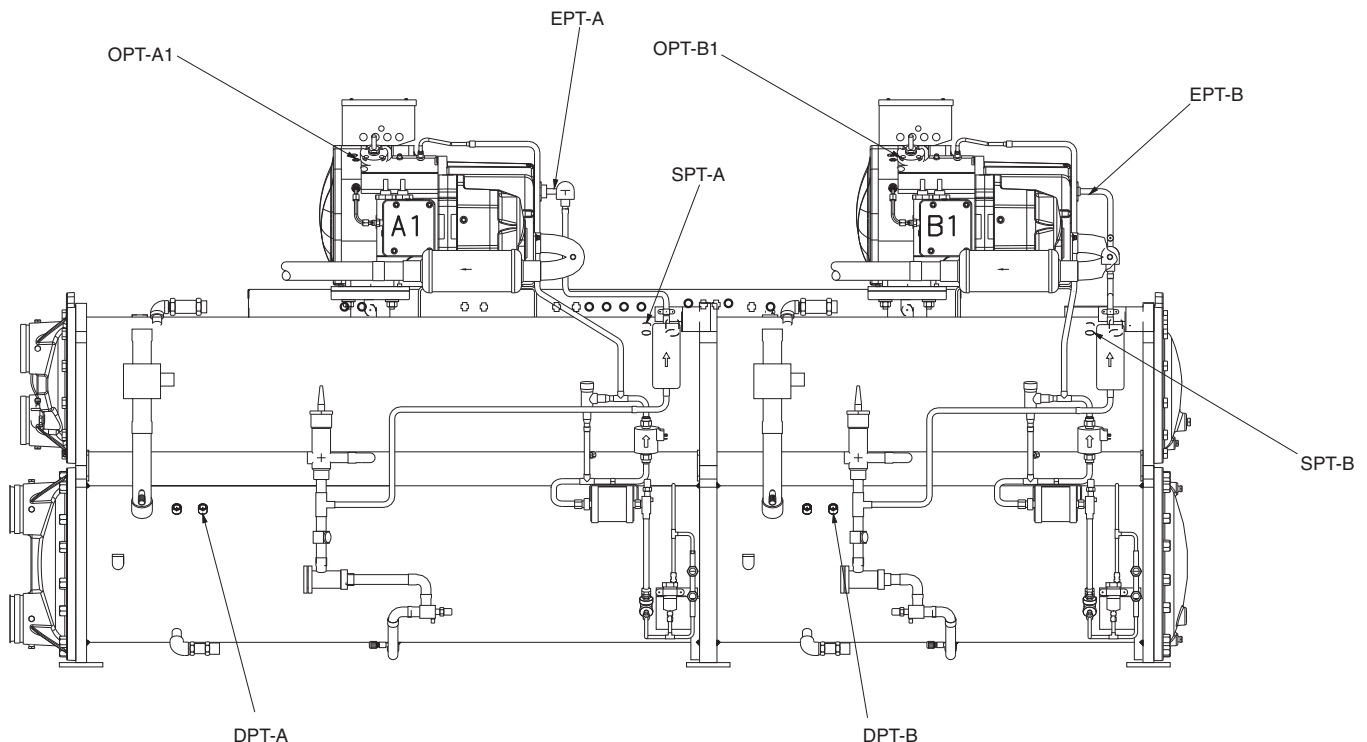

Fig. 29A — 30HX Pressure Transducer Locations (2-Compressor Unit)

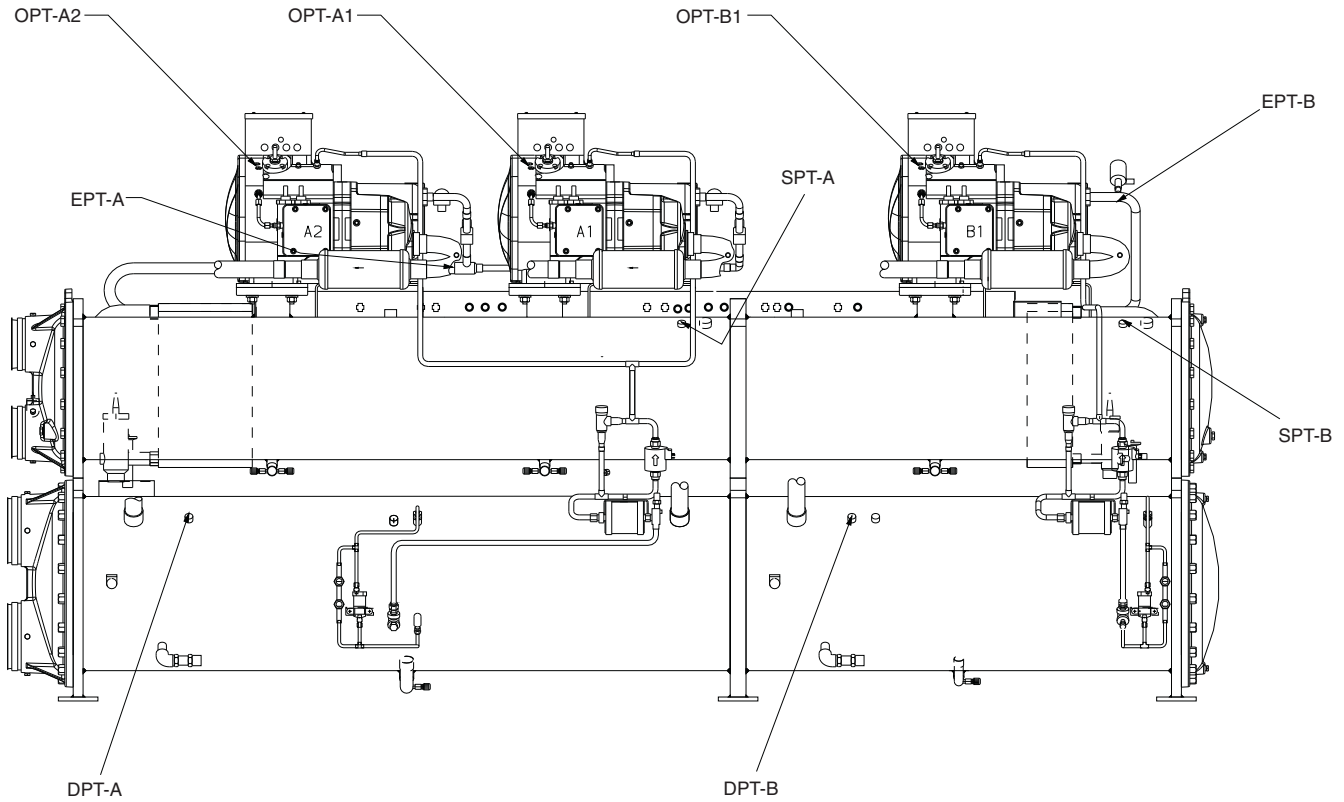

Fig. 29B — 30HX Pressure Transducer Locations (3-Compressor Unit)

LEGEND FOR FIG. 29A-29B

- DPT** — Discharge Pressure Transducer
- EPT** — Economizer Pressure Transducer
- EXV** — Electronic Expansion Valve
- OPT** — Oil Pressure Transducer
- SPT** — Suction Pressure Transducer

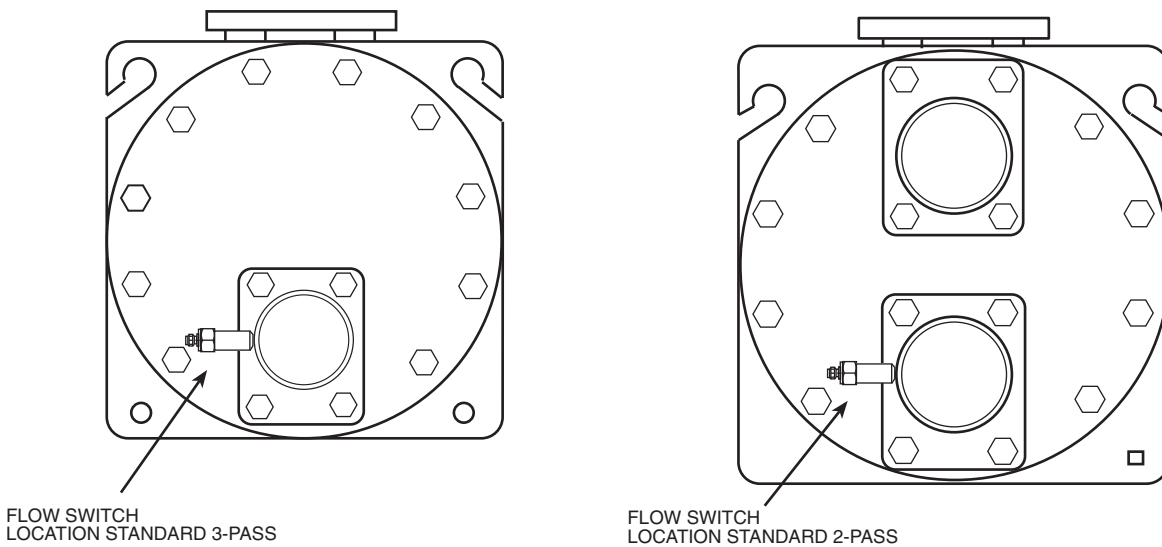

Fig. 30 — Typical Location of Flow Sensor

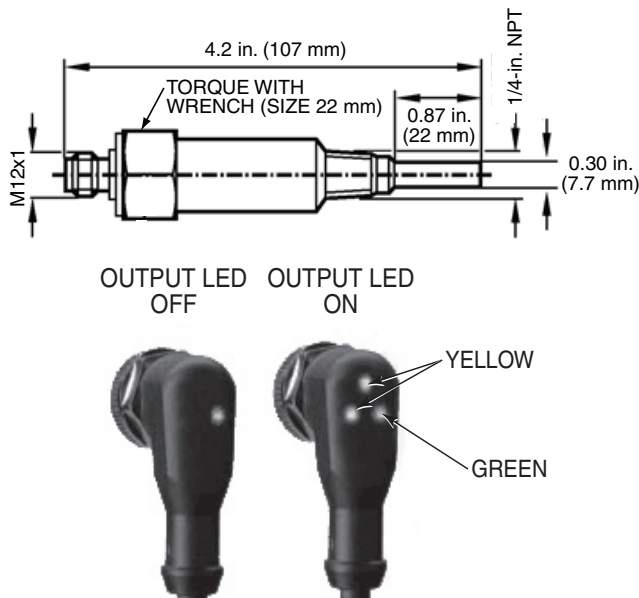

Fig. 31 — Chilled Water Flow Sensor LED Display

Safety Devices — The 30HX chillers contain many safety devices and protection logic built into the electronic control. Following is a description of the major safeties.

COMPRESSOR PROTECTION

Motor Overload — The compressor protection modules (CPM) protect each compressor against overcurrent. Do not bypass the current transformers or make any changes to the DIP switch S2 setting. The S2 setting defines the Must Trip Amps (MTA) at which the CPM will turn the compressors off. Determine the cause for trouble and correct the problem before resetting the CPM. See Appendix A for setting of MTAs.

Each CPM also reads the status of each compressor's high-pressure switch. All compressors have factory-installed high-pressure switches. See Table 38.

Table 38 — High-pressure Switch Settings

UNIT	SWITCH SETTING	
	psig	kPa
30HXA	275 ±7	1896 ±48
30HXC	191 ±7	1317 ±48

If the switch opens during operation, the compressor will be shut down. The CPM will reset automatically when the switch closes, however, a manual reset is required to restart the compressor.

COOLER PROTECTION

Low Water Temperature — Microprocessor is programmed to shut the chiller down if the leaving fluid temperature drops below 34 F (1.1 C) for water or more than 8° F (4.4° C) below brine freeze set point for brine units. When the fluid temperature rises 6° F (3.3° C) above the leaving fluid set point, the safety resets and the chiller restarts. Reset is automatic as long as this is the first occurrence of the day.

IMPORTANT: If the unit is installed in an area where ambient temperatures fall below 32 F (0° C), cooler heaters and inhibited ethylene glycol or other suitable solution must be used in the chilled fluid circuit.

Relief Devices

PRESSURE RELIEF VALVES — Valves are installed in each circuit and are located on all coolers. One relief valve is also installed on each 30HXC condenser. Both circuits' oil separators on 30HXA units have factory-installed relief valves as well. These valves are designed to relieve if an abnormal

pressure condition arises. Relief valves on all coolers and 30HXC condensers relieve at 220 psi (1517 kPa). Relief valves on 30HXA oil separators relieve at 320 psi (2206 kPa). All 30HXA, HXC units with factory-installed suction service valves also have a relief valve in each compressor discharge line. These valves are designed to relieve at 350 psig (2413 kPa). These valves should not be capped. If a valve relieves, it should be replaced. If the valve is not replaced, it may relieve at a lower pressure, or leak due to trapped dirt from the system which may prevent resealing.

Pressure relief valves located on cooler and condenser shells and 30HXA oil separator shells have 3/4-in. NPT connections for relief. Some local building codes require that relieved gases be removed. This connection allows conformance to this requirement.

Control Modules

CAUTION

Turn controller power off before servicing controls. This ensures safety and prevents damage to controller.

MAIN BASE BOARD (MBB), AUXILIARY BOARD (AUX), EXPANSION VALVE BOARD (EXV), ENERGY MANAGEMENT MODULE (EMM), COMPRESSOR PROTECTION MODULE (CPM) AND THE NAVIGATOR™ MODULE — All of the modules perform continuous diagnostic evaluations of the condition of the hardware. Proper operation and communication of these modules is indicated by LEDs on the surface of each module (all except the Navigator that displays 'Communication Failure' when it occurs).

RED LED — All module red LEDs will blink in unison at a 1 to 2 second rate when communicating and functioning properly. Lighted continuously indicates a problem requiring replacement of module. Off continuously indicates power should be checked. If there is no input power, check fuses. If fuse is bad, check for shorted secondary of transformer, tripped circuit breaker or bad module. An LED blinking at a rate of twice per second indicates potential loss of program. The suspect board(s) should be downloaded using the SmartLoader program. If this is not successful, the module should be replaced.

GREEN LED — Each module has a green LED that should always be blinking when power is on. Each module's green LED will be blinking at different rates. This is a normal condition. If the green LED is not blinking, check the red LED. If the red LED is normal, verify that all communication connections (J3 for MBB, J9 for AUX, EXV, EMM and J12 for CPM-A1, B1 and A2) are correct. If wiring is correct, check the Main Base Board instance jumper (should be set to '1'). The EXV, EMM and AUX module address switches should all be set to ON. For CPM-A1, switch 1,2,3,4 should be off. For CPM-B1, switch 1,2,3,4 should be off and switch 3 should be on. For CPM-A2, switch 1,2,3 should be off and switch 4 should be on. Remote terminal strip (TB3) connections are made to the Main Base Board at plug MBB-J5.

YELLOW LED — The Main Base Board (MBB) has a yellow LED. This light will blink whenever CCN (Carrier Comfort Network) communications are in progress. Only the MBB is designed to communicate on the CCN bus. All other modules (including the Navigator module) are designed to communicate only on the LEN bus.

The majority of the system operating intelligence resides in the MBB, however each individual module does have its own operating software. The machine operator communicates with the MBB through the Navigator module. Communications between all modules is accomplished by a 3-wire sensor bus called the Local Equipment Network (LEN). These 3 wires run in parallel from module to module.

For all models, control modules are powered by 24 vac power sources protected by circuit breakers. Separate power sources are used for the CPM modules. Refer to the 24-v wiring schematic located on the chiller for detailed information. Refer to Table 39 for control troubleshooting information.

Carrier Comfort Network® (CCN) Interface —

The 30HX chiller units can be connected to the CCN if desired. The communication bus wiring is a shielded, 3-conductor cable with drain wire and is supplied and installed in the field. The system elements are connected to the communication bus in a daisy chain arrangement. The positive pin of each system element communication connector must be wired to the positive pins of each system element. Wiring connections for CCN can be made at terminal block TB3. There are four terminals (including shield) located at TB3 for permanent CCN connection. For temporary CCN connection to the chiller, there is also an RJ-11 (6 position, 6 conductor) connector. The connector is for field connection of a laptop computer running Service Tool or ComfortVIEW™ software programs. Consult CCN Contractor's Manual for further information.

NOTE: Conductors and drain wire must be 20 AWG (American Wire Gage) minimum stranded, tinned copper. Individual conductors must be insulated with PVC, PVC/nylon, vinyl, Teflon, or polyethylene. An aluminum/polyester 100% foil shield and an outer jacket of PVC, PVC/nylon, chrome vinyl, or Teflon with a minimum operating temperature range of -20 C to 60 C is required. Wire manufactured by Alpha (2413 or 5463), American (A22503), Belden (8772), or Columbia (02525) meets the above mentioned requirements.

It is important when connecting to a CCN communication bus that a color coding scheme be used for the entire network to simplify the installation. It is recommended that red be used for the signal positive, black for the signal negative, and white

for the signal ground. Use a similar scheme for cables containing different colored wires.

At each system element, the shields of its communication bus cables must be tied together. If the communication bus is entirely within one building, the resulting continuous shield must be connected to a ground at one point only. If the communication bus cable exits from one building and enters another, the shields must be connected to grounds at the lightning suppressor in each building where the cable enters or exits the building (one point per building only).

IMPORTANT: A shorted CCN bus cable will prevent some routines from running and may prevent the unit from starting. If abnormal conditions occur, disconnect the CCN bus. If conditions return to normal, check the CCN connections and cable. Run new cable if necessary. A short in one section of the bus can cause problems with all system elements on the bus.

Replacing Defective Modules — The *ComfortLink™* replacement modules are shown in Table 40. The unit model and serial numbers are printed on the unit nameplate located on the corner of the control box (30HX). The basic software and unit configuration data is factory installed by Carrier in the replacement module. Therefore, when ordering any replacement module, specify the replacement part number (located on each module front or back), *full* unit model number and serial number. The replacement modules will be downloaded with the basic software. If the Main Base Board (MBB) has been replaced, verify that all configuration data is correct. Follow the Configuration mode table and verify that all items under sub-modes UNIT, OPT1 and OPT2 are correct. Any additional field-installed accessories or options (sub-mode RSET,SLCT) should also be verified.

Table 39 — Compressor Control Troubleshooting

SYMPTOMS	CAUSE	REMEDY
COMPRESSOR DOES NOT RUN	Power line open Control fuse open High-Pressure Switch (HPS) tripped Loose terminal connection Improperly wired controls Low line voltage Compressor motor defective Seized compressor Pre-lubrication not successful	Check main disconnect. Check control circuit for ground or short. Replace fuse. Use Navigator to reset current alarms. Check connections from CPM to contactor Check wiring and rewire. Check line voltage. Determine location of voltage drop and remedy deficiency. Check motor winding for open or short. Replace compressor if necessary. Replace compressor. Check oil pump operation, oil pressure transducer, verify oil solenoid valve operation.
COMPRESSOR CYCLES OFF ON LOW SATURATED SUCTION TEMPERATURE	Loss of charge Bad transducer Low refrigerant charge Failed expansion device Partially plugged or plugged strainer	Repair leak and recharge. Replace transducer. Add refrigerant. Repair/replace as needed. Remove and clean strainer.
COMPRESSOR SHUTS DOWN ON HIGH PRESSURE CONTROL	High-pressure switch erratic in action Compressor discharge valve partially closed Condenser fan(s) not operating (air cooled units) Condenser coil plugged or dirty (air cooled units) Condenser water valve not operating (water cooled units) Circuit overcharged	Replace switch. Open valve or replace if defective. Check wiring. Repair or replace motor(s) if defective. Clean coil. Check wiring. Repair or replace valve if defective. Adjust refrigerant charge. Check for noncondensables.
UNIT OPERATES LONG OR CONTINUOUSLY	Low refrigerant charge Control contacts fused Partially plugged or plugged strainer Defective insulation Service load exceeding design capacity Inefficient compressor	Add refrigerant. Replace control. Clean or replace. Replace or repair. Evaluate load requirements. Check loader solenoid valves. Replace if necessary.
SYSTEM NOISES	Piping vibration Expansion valve hissing Compressor noisy	Support piping as required. Add refrigerant. Check for plugged liquid line strainer. Replace compressor (worn bearings). Check for loose compressor bolts securing compressor to cooler.
COMPRESSOR LOSES OIL	Leak in system Mechanical damage to rotors	Find and repair leak. Replace compressor.
HOT LIQUID LINE	Shortage of refrigerant due to leak	Repair leak and recharge.
FROSTED LIQUID LINE	Shutoff valve partially closed or restricted	Open valve or remove restriction.
COMPRESSOR LOADERS NOT WORKING PROPERLY	Burned out coil Defective loader solenoid valve Miswired solenoid	Replace coil. Replace valve. Rewire correctly.

Table 40 — Replacement Module Part Number

MODULE	REPLACEMENT PART NUMBER (With Software)	REPLACEMENT PART NUMBER (Without Software)
Main Base Board (MBB)	30GX506748	HK50AA029
Expansion Valve Board (EXV)	30HX515217	HK50AA026
AUX Board (AUX)	32GB500 442 EE	N/A
Navigator™ Display	HK50AA033	N/A
Energy Management Module (EMM)	30HX515218	HK50AA028
Compressor Protection Module (CPM)	00PSG000469000A	N/A

Refer to the Start-Up Checklist for 30HX Liquid Chillers (completed at time of original start-up) found in the job folder. This information is needed later in this procedure. If the checklist does not exist, fill out the current information in the Configuration mode on a new checklist. Tailor the various options and configurations as needed for this particular installation.

CAUTION

Electrical shock can cause personal injury. Disconnect all electrical power before servicing.

1. Check that all power to unit is off. Carefully disconnect all wires from the defective module by unplugging its connectors.
2. Remove the defective module by removing its mounting screws with a Phillips screwdriver, and removing the module from the control box. Save the screws later use. For Navigator module replacement, remove the screw securing the cable clamp near TB3.
3. Verify that the instance jumper (MBB) or address switches (all other modules) exactly match the settings of the defective module.
4. Package the defective module in the carton of the new module for return to Carrier.
5. Mount the new module in the unit's control box using a Phillips screwdriver and the screws saved in Step 2.
6. Reinstall all module connectors. For Navigator module replacement, make sure the plug is installed at TB3 in the LEN connector.
7. Carefully check all wiring connections before restoring power.
8. Verify the Enable/Off/Remote Contact switch is in the OFF position.
9. Restore control power. Verify that all module red LEDs blink in unison. Verify that all green LEDs are blinking and that the Navigator is communicating correctly.
10. Verify all configuration information, settings, setpoints and schedules. Return the Enable/Off/Remote Contact switch to normal operation position.

Winter Shutdown Preparation — At the end of each cooling season the fluid should be drained from the system. However, due to the cooler circuiting, some fluid will remain in the cooler after draining. To prevent freeze-up damage to the cooler tubes perform the following procedure.

1. Drain the fluid from the system.
2. Isolate the cooler from the rest of the system with water shut off valves.

3. Completely fill the cooler with an appropriate amount of inhibited ethylene glycol solution (or other suitable corrosion-inhibitive antifreeze) for 15° F (8.3° C) below the expected low ambient conditions (5 gallon [19 L] minimum).
4. Leave the cooler filled with the antifreeze solution for the winter, or drain if desired. Be sure to deenergize heaters (if installed) as explained in Step 1 to prevent damage. Use an approved method of disposal when removing the antifreeze solution.
5. Update item W.DNE *Winterization Performed* (Configuration Mode, Sub-mode SERV) to YES. Winterization is complete.

Maintenance

RECOMMENDED MAINTENANCE SCHEDULE — The following are only recommended guidelines. Job site conditions may dictate that maintenance schedules be performed more frequently than listed here.

MONTHLY (as conditions dictate)

All machines:

- Check moisture indicating sight glass for possible refrigerant loss and presence of moisture.

30HXA machines:

- Refer to remote condenser manufacturer's maintenance recommendations

EVERY 3 MONTHS

All machines:

- Check all refrigerant joints and valves for refrigerant leaks, repair as necessary.
- Check moisture indicating sight glass for possible refrigerant loss and presence of moisture.
- Check oil filter pressure drops, replace as necessary.
- Check chilled water flow switch operation.

YEARLY:

All machines:

- Check all electrical connections. Tighten as necessary.
- Check accuracy of all transducers for each circuit, replace as necessary.
- Check accuracy of thermistors, replace if greater than ± 2° F (1.2° C) variance from calibrated thermometer.
- Obtain and test an oil sample, change as necessary.
- Clean cooler tubes if appropriate.
- Check to be sure that the proper concentration of anti-freeze is present in the chilled water loop.
- Check to be sure that the proper amount of inhibitor is present in the chilled water loop.
- Check all refrigerant strainers and filter driers for pressure drops, replace or clean as necessary.
- Check chilled water strainers, clean as necessary.

30HXC machines:

- Check condenser water regulating valve operation, if equipped.
- Clean condenser tubes if appropriate.
- Check condenser water strainers, clean as necessary.

PRE-START-UP PROCEDURE

IMPORTANT: Before beginning Pre-Start-Up or Start-Up, complete the Start-Up Checklist for the 30HX Liquid Chillers on pages CL-1 to CL-10. This Checklist assures proper start-up of the chiller, and provides a record of unit condition, application requirements, system information and operation at initial start-up. The checklist should be removed from the manual and kept with the job file for future reference.

IMPORTANT: DO NOT ATTEMPT TO START THE CHILLER UNTIL THE FOLLOWING CHECKS HAVE BEEN COMPLETED.

CAUTION

DO NOT make any changes to the factory-installed compressor power wiring in the control box or at the compressor junction box. Doing so will cause permanent damage to the compressor and will require compressor replacement. Proper phasing has already been checked at the factory.

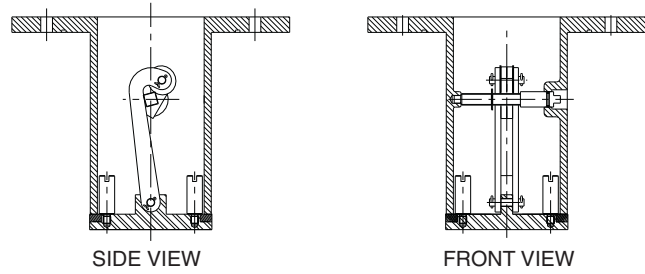

Fig. 32 — Suction Valve Detail

System Check

1. Check all auxiliary components such as the chilled fluid circulating pump, air-handling equipment, or other equipment to which the chiller supplies liquid. Consult the manufacturer's instructions. If the unit has field-installed accessories, be sure all are properly installed and wired correctly. Refer to the unit wiring diagrams.
2. Check the cooler flow switch for proper operation (item 'FLOW', Inputs mode under sub-mode GEN.I). Ensure sensor contacts close when the pump is on and open when the pump is turned off. A flow switch is factory installed on all models with two or more pass coolers. For single pass cooler models, the flow switch is factory supplied for field installation with factory-supplied victaulic nozzles.
3. Open the discharge and liquid valves in each circuit. Both shutoff valves are in-line ball type and are open when stem is parallel with the refrigerant flow.
4. If factory-installed suction service valves are installed, open the suction service valves in each circuit. Service valve is located below the compressor in the cooler suction connection flange. To operate the valve, first remove the cap. Use a back-up wrench on the packing gland to prevent loosening while removing cap. Loosen the jam nut. Rotating the valve handle clockwise will close valve and counterclockwise will open valve. When closing the valve, the linkage arm must swing past center of the actuator shaft cam to seat and prevent accidental opening of the valve. Tighten the jam nut. See Fig. 32 and 33.
5. Before filling the system with fluid following a winter shutdown, check the chilled water loop for pressure. Higher than atmospheric pressure could be the result of a refrigerant leak in the cooler.
6. Open the oil shutoff valves located by the oil pre-filter, and the ball valve to each compressor.
7. Check the tightness of all electrical connections. Check incoming power supply for proper nameplate voltage.
8. Check to ensure the unit is level per the installation instructions.
9. Check all field configuration data and set points.
10. Enter correct date, time, and operating schedule(s).
11. Verify operation of solenoids, pumps, valves, compressors, fans, etc. as listed in the Start-Up Checklist.
12. Open condenser water valves. Check condenser water pump for proper operation (30HXC).

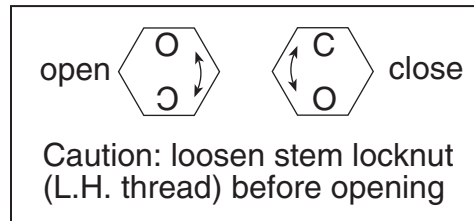
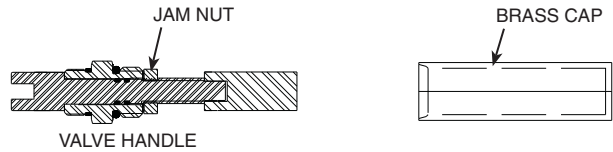

Fig. 33 — Suction Valve Handle Details

START-UP AND OPERATION

Actual Start-Up — Actual start-up should be done only under supervision of a qualified refrigeration mechanic and qualified Carrier Comfort Network® personnel.

1. Set leaving fluid temperature. No cooling range adjustment is necessary.
2. Start chilled fluid pump and condenser pump (30HXC) if not controlled by unit.
3. Switch Enable/Off/Remote Contact switch to Enable or Remote Contact.
4. Provided there is a load on the chiller, allow the machine to operate and confirm that everything is functioning properly. Verify that the leaving fluid temperature agrees with the cooling set point (1 or 2), or if reset is being used, the modified set point. Chiller is controlling to the Control Point (item 'CTPT') displayed on the Navigator module.

Operating Sequence — The chiller is started by switching the Enable/Off/Remote Contact switch to either Enable or Remote Contact position. If cooler pump control is enabled, the cooler pump is started. If condenser pump control (30HXC) is enabled, the condenser pump is started. On a command for cooling, the oil pump is turned on to start the pre-lubrication process. After 20 seconds, the oil solenoid is opened and the control reads the oil pressure from the transducer and determines if sufficient pressure has been built up. If there is not sufficient pressure, an alarm is generated after the second attempt and the compressor is not started.

Upon building pressure, the compressor is allowed to start (after 15 seconds). For across-the-line (XL) start chillers, the compressor starts and comes up to full speed within 1 to 3 seconds. For Wye-Delta start chillers, contactors 1M and S (starter contactor assembly) are closed and the compressor is started in a Wye configuration. This method reduces the locked rotor current requirements by approximately 60% while maintaining enough torque to bring the compressor up to full speed.

FIELD WIRING

Field wiring is shown in Fig. 34-46.

LEGEND FOR FIG. 34-46

- ALM — Alarm
- AUX — Auxiliary Board
- CFR — Condenser Fan Relay
- CMP — Chiller Water Pump
- CNFS — Condenser Flow Switch
- CNPI — Condenser Pump Interlock
- CNP-R — Condenser Pump Relay
- CWP — Chilled Water Pump
- EMM — Energy Management Module
- EWT — Entering Water Thermistor
- FIOP — Factory-Installed Option
- FSR — Flow Switch Relay
- FU — Fuse
- GFI-CO — Ground Fault Interrupter Convenience Outlet
- GND — Ground
- LLSV — Liquid Line Solenoid Valve
- LWT — Leaving Water Thermistor
- MBB — Main Base Board
- MLV — Minimum Load Valve
- NEC — National Electrical Code
- OAT — Outdoor-Air Thermistor
- SPT — Space Temperature Sensor
- SW — Switch
- TB — Terminal Block
- - - - - Field-Wired
- Factory Wired

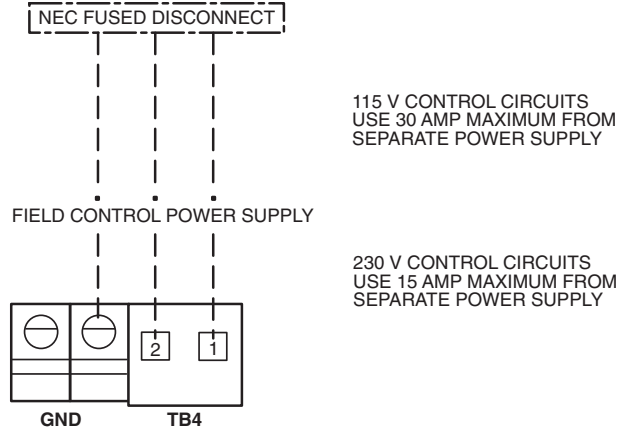

Fig. 34 — Power Supply Wiring

* Dependent on control circuit power supply voltage.

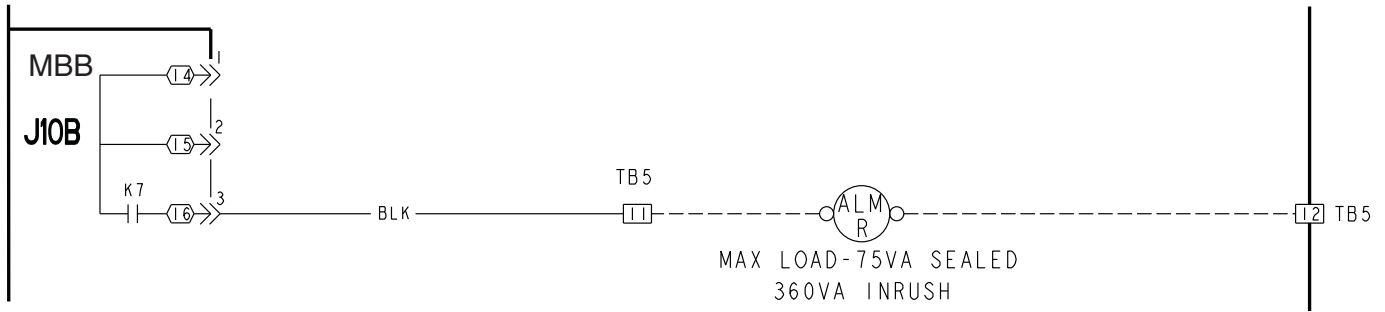

Fig. 35 — Remote Alarm Relay Accessory Wiring; All Models, 115 or 230 V*

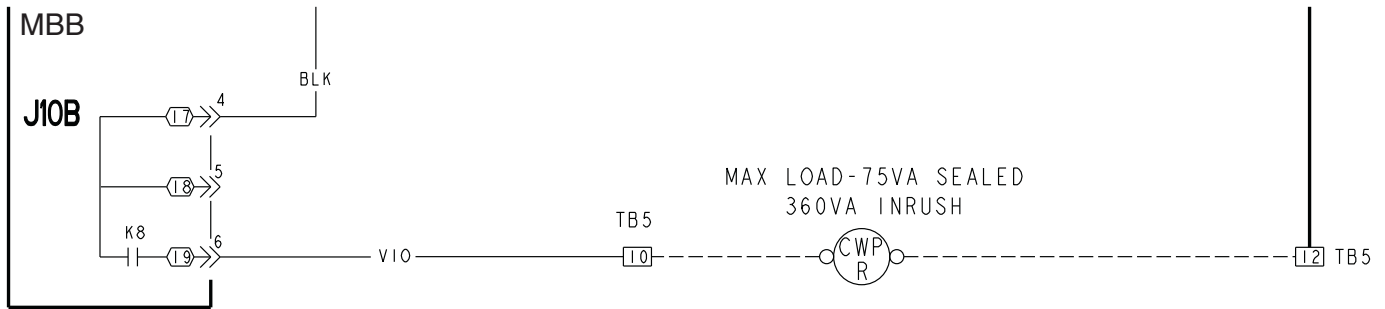

Fig. 36 — Chilled Water Pump Relay Wiring; All Models, 115 or 230 V*

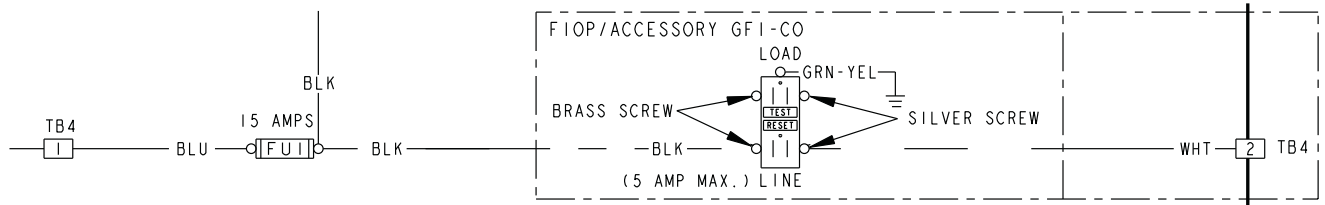

Fig. 37 — Optional Ground Fault Interrupter; Convenience Outlet Accessory Wiring

MAIN BASE BOARD

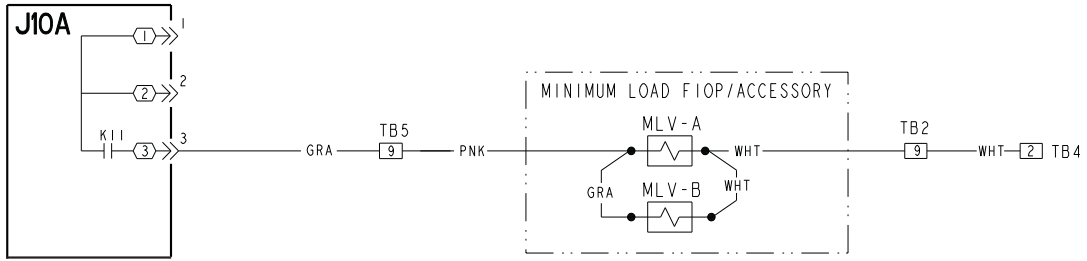

Fig. 38 — 30HX Minimum Load Valve Accessory Wiring, 115 or 230 V*

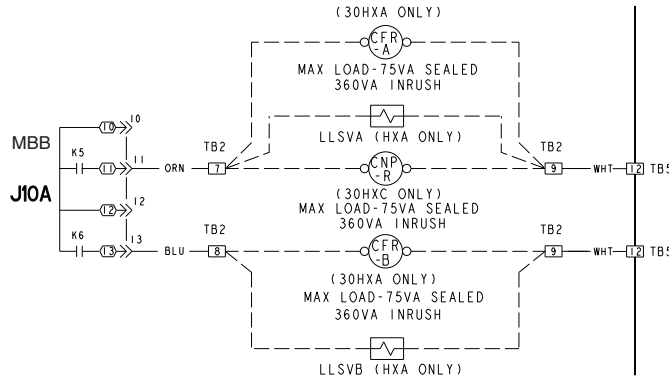

Fig. 39 — Condenser Pump Relay Wiring; 30HXC and Remote Condenser Fan/Liquid Line Solenoid Valve Wiring; 30HXA 115 or 230 V*

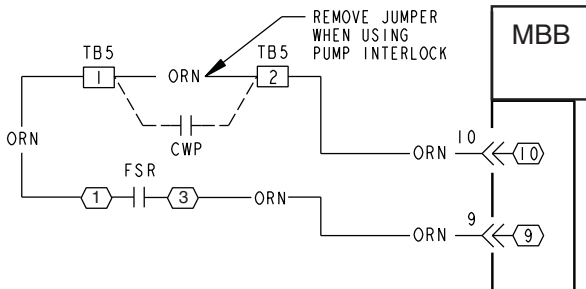

Fig. 40 — Chilled Water Interlock and Flow Switch Input Wiring

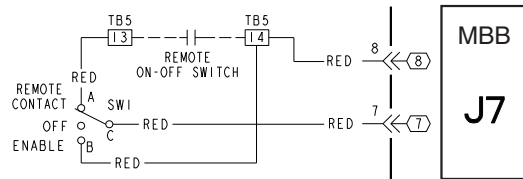

Fig. 41 — Remote On/Off Switch Input Wiring

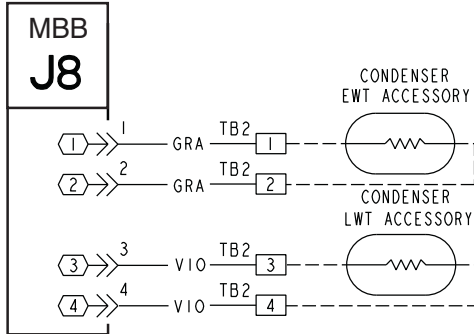
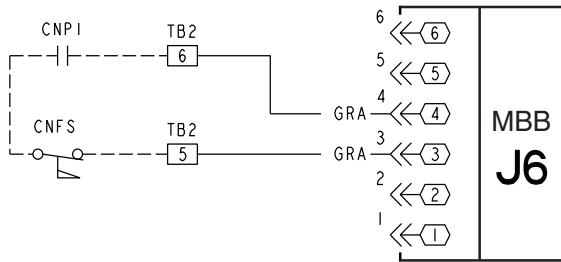

Fig. 42 — Condenser Flow Switch Interlock and Entering/Leaving Water Thermistor Wiring; 30HXC Units

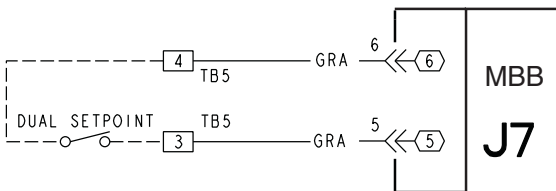

Fig. 43 — Remote Dual Setpoint Wiring; All Units

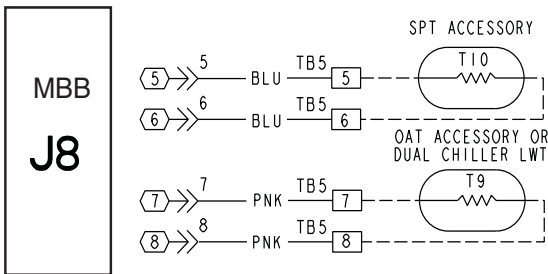
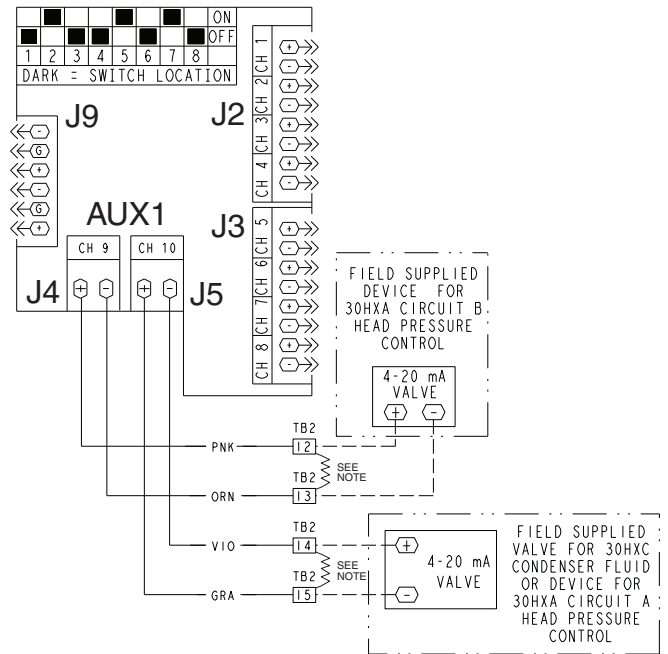
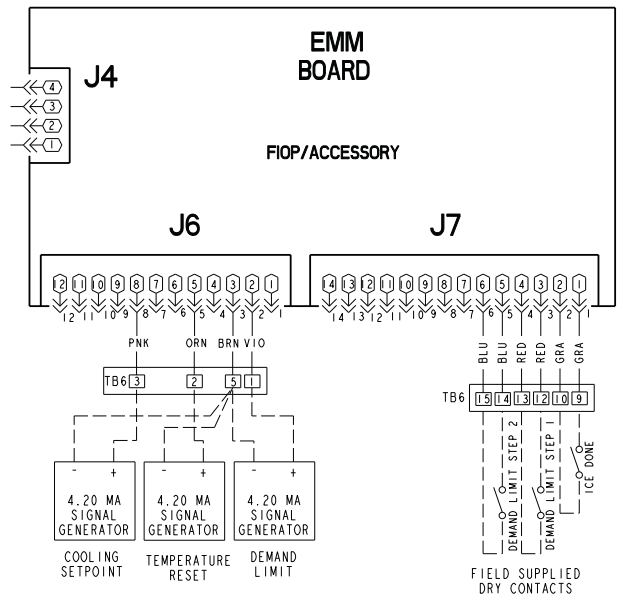

Fig. 44 — Outdoor-Air Thermistor (5KΩ at 77 F [25 C]) and Space Temperature Sensor (10KΩ at 77 F [25 C]) All Units, Field Supplied



NOTE: Install a 500 Ω resistor across output terminals to convert output signal to 2-10 vdc.

Fig. 45 — Field-Supplied Head Pressure Device Wiring; 30HX Units



NOTE: Use signal converter for input types other than 4-20 mA.

Fig. 46 — Energy Management Module Option or Accessory Wiring; All Units

APPENDIX A — COMPRESSOR MUST TRIP AMP (MTA) SETTINGS

MTA Setting for 30HXA,HXC076-186 with XL Starter* (1 = ON, 0 = OFF)

UNIT	V-PH-HZ	COMPRESSOR A1																COMPRESSOR B1																				
		S1 Setting								MTA	S2 Value	S2 Setting								S1 Setting								MTA	S2 Value	S2 Setting								
		1	2	3	4	5	6	7	8			1	2	3	4	5	6	7	8	1	2	3	4	5	6	7	8			1	2	3	4	5	6	7	8	
30HXA076	575-3-60	0	1	0	0	0	0	0	0	80	20	0	0	1	0	1	0	0	0	0	0	1	0	0	0	0	0	0	80	20	0	0	1	0	1	0	0	0
	380-3-60	0	1	0	0	0	0	0	0	122	41	1	0	0	1	0	1	0	1	0	0	0	1	0	0	0	0	0	122	41	1	0	0	1	0	1	0	0
	460-3-60	0	1	0	0	0	0	0	0	100	30	0	1	1	1	1	0	0	0	0	0	1	0	0	0	0	0	100	30	0	1	1	1	1	0	0	0	
	380/415-3-50	0	1	0	0	0	0	0	0	126	43	1	1	0	1	0	1	0	0	0	0	1	0	0	0	0	0	126	43	1	1	0	1	0	1	0	0	
30HXA086	575-3-60	0	1	0	0	0	0	0	0	96	28	0	0	1	1	1	0	0	0	0	0	1	0	0	0	0	0	96	20	0	0	1	0	1	0	0	0	
	380-3-60	0	1	0	0	0	0	0	0	146	53	1	0	1	0	1	1	0	0	0	0	1	0	0	0	0	122	41	1	0	0	1	0	1	0	0		
	460-3-60	0	1	0	0	0	0	0	0	120	40	0	0	0	1	0	1	0	0	0	0	1	0	0	0	0	100	30	0	1	1	1	1	0	0	0		
	380/415-3-50	0	1	0	1	0	0	0	0	154	57	1	0	0	1	1	1	0	0	0	0	1	0	0	0	0	126	43	1	1	0	1	0	1	0	0		
30HXA096	575-3-60	0	1	0	0	0	0	0	0	118	39	1	1	1	0	0	1	0	0	0	0	1	0	0	0	0	80	20	0	0	1	0	1	0	0	0		
	380-3-60	0	1	0	1	0	0	0	0	178	69	1	0	1	0	0	0	1	0	0	0	1	0	0	0	0	122	41	1	0	0	1	0	1	0	0		
	460-3-60	0	1	0	0	0	0	0	0	146	53	1	0	1	0	0	1	1	0	0	0	1	0	0	0	0	100	30	0	1	1	1	1	0	0	0		
	380/415-3-50	0	1	0	1	0	0	0	0	186	73	1	0	0	1	0	0	1	0	0	0	1	0	0	0	0	126	43	1	1	0	1	0	1	0	0		
30HXA106	575-3-60	0	1	0	0	0	0	0	0	142	51	1	1	0	0	1	1	0	0	0	0	1	0	0	0	0	80	20	0	0	1	0	1	0	0	0		
	380-3-60	0	1	0	1	0	0	0	0	216	88	0	0	0	0	1	1	0	0	0	0	1	0	0	0	0	122	41	1	0	0	1	0	1	0	0		
	460-3-60	0	1	0	1	0	0	0	0	178	69	1	0	1	0	0	0	0	0	0	0	1	0	0	0	0	100	30	0	1	1	1	1	0	0	0		
	380/415-3-50	0	1	0	1	0	0	0	0	226	93	1	0	1	1	1	0	1	0	0	0	1	0	0	0	0	126	43	1	1	0	1	0	1	0	0		
30HXA116	575-3-60	0	1	0	0	0	0	0	0	142	51	1	1	0	0	1	1	0	0	0	0	1	0	0	0	0	96	28	0	0	1	1	1	0	0	0		
	380-3-60	0	1	0	1	0	0	0	0	216	88	0	0	0	1	1	0	1	0	0	0	1	0	0	0	0	146	53	1	0	1	0	1	1	0	0		
	460-3-60	0	1	0	1	0	0	0	0	178	69	1	0	1	0	0	0	0	0	0	0	1	0	0	0	0	120	40	0	0	0	1	0	1	0	0		
	380/415-3-50	0	1	0	1	0	0	0	0	226	93	1	0	1	1	1	0	1	0	0	0	1	0	0	0	0	154	57	1	0	0	1	1	1	0	0		
30HXA126	575-3-60	0	1	0	0	0	0	0	0	142	51	1	1	0	0	1	1	0	0	0	0	1	0	0	0	0	118	39	1	1	1	0	0	1	0	0		
	380-3-60	0	1	0	1	0	0	0	0	216	88	0	0	0	1	1	0	1	0	0	0	1	0	0	0	0	178	69	1	0	1	0	0	0	1	0		
	460-3-60	0	1	0	1	0	0	0	0	178	69	1	0	1	0	0	0	0	0	0	0	1	0	0	0	0	146	53	1	0	1	0	1	1	0	0		
	380/415-3-50	0	1	0	1	0	0	0	0	226	93	1	0	1	1	1	0	1	0	0	0	1	0	0	0	0	186	73	1	0	0	1	0	0	1	0		
30HXA136	575-3-60	0	1	0	1	0	0	0	0	174	67	1	1	0	0	0	0	1	0	0	0	1	0	0	0	0	118	39	1	1	1	0	0	1	0	0		
	380-3-60	0	1	0	1	0	0	0	0	264	112	0	0	0	0	1	1	1	0	0	0	1	0	0	0	0	178	69	1	0	1	0	0	0	0	1		
	460-3-60	0	1	0	1	0	0	0	0	218	89	1	0	0	1	1	0	1	0	0	0	1	0	0	0	0	146	53	1	0	1	0	1	1	0	0		
	380/415-3-50	0	1	0	1	0	0	0	0	278	119	1	1	1	0	1	1	1	0	0	0	1	0	0	0	0	186	73	1	0	0	1	0	0	1	0		
30HXA146	575-3-60	0	1	0	1	0	0	0	0	174	67	1	1	0	0	0	0	1	0	0	0	1	0	0	0	0	142	51	1	1	0	0	1	1	0	0		
	380-3-60	0	1	0	1	0	0	0	0	264	112	0	0	0	0	1	1	1	0	0	0	1	0	0	0	0	216	88	0	0	0	1	1	0	1	0		
	460-3-60	0	1	0	1	0	0	0	0	218	89	1	0	0	1	1	0	1	0	0	0	1	0	0	0	0	178	69	1	0	1	0	0	0	0	1		
	380/415-3-50	0	1	0	1	0	0	0	0	278	119	1	1	1	0	1	1	1	0	0	0	1	0	0	0	0	226	93	1	0	1	0	1	1	0	1		
30HXA161	575-3-60	0	1	0	1	0	0	0	0	196	78	0	1	1	1	0	0	0	0	0	0	1	0	0	0	0	132	46	0	1	1	1	0	1	0	0		
	380-3-60	0	1	0	1	0	0	0	0	298	129	1	0	0	0	0	0	0	0	0	0	1	0	0	0	0	200	80	0	0	0	0	1	0	0	1		
	460-3-60	0	1	0	1	0	0	0	0	246	103	1	1	1	0	0	0	1	1	0	0	0	0	0	0	0	166	63	1	1	1	1	1	1	0	0		
	380/415-3-50	0	1	0	0	1	0	0	0	310	15	1	1	1	1	0	0	0	0	0	0	0	1	0	0	0	0	206	83	1	1	0	0	1	0	1	0	
30HXA171	575-3-60	0	1	0	1	0	0	0	0	160	60	0	0	1	1	1	1	0	0	0	0	1	0	0	0	0	196	78	0	1	1	1	0	0	1	0		
	380-3-60	0	1	0	1	0	0	0	0	244	102	0	1	1	0	0	0	1	1	0	0	0	0	0	0	0	298	129	1	0	0	0	0	0	0	1		
	460-3-60	0	1	0	1	0	0	0	0	202	81	1	0	0	0	1	0	1	0	0	0	1	0	0	0	0	246	103	1	1	1	0	0	1	1	0		
	380/415-3-50	0	1	0	1	0	0	0	0	252	106	0	1	0	1	0	1	1	0	0	0	0	1	0	0	0	310	15	1	1	1	1	0	0	0	0		
30HXA186	575-3-60	0	1	0	1	0	0	0	0	196	78	0	1	1	1	0	0	0	0	0	0	1	0	0	0	0	196	78	0	1	1	1	1	0	0	1		
	380-3-60	0	1	0	1	0	0	0	0	298	129	1	0	0	0	0	0	0	0	0	0	1	0	0	0	0	298	129	1	0	0	0	0	0	0	1		
	460-3-60	0	1	0	1	0	0	0	0	246	103	1	1	1	0	0	1	1	0	0	0	1	0	0	0	0	246	103	1	1	1	0	0	1	1	0		
	380/415-3-50	0	1	0	0	1	0	0	0	310	15	1	1	1	1	0	0	0	0	0	0	0	1	0	0	0	0	310	15	1	1	1	1	0	0	0	0	

* XL starter not available on 230-3-60, 208/230-3-60, or 230-3-50 units.

APPENDIX A — COMPRESSOR MUST TRIP AMP (MTA) SETTINGS (cont)

MTA Setting for 30HXA,HXC076-186 with XL Starter* (1 = ON, 0 = OFF) (cont)

UNIT	V-PH-HZ	COMPRESSOR A1																COMPRESSOR B1																			
		S1 Setting								MTA	S2 Value	S2 Setting								S1 Setting								MTA	S2 Value	S2 Setting							
		1	2	3	4	5	6	7	8			1	2	3	4	5	6	7	8	1	2	3	4	5	6	7	8			1	2	3	4	5	6	7	8
30HXC076	575-3-60	0	1	0	0	0	0	0	54	7	1	1	1	0	0	0	0	0	0	1	0	0	0	0	0	0	54	7	1	1	1	0	0	0	0	0	
	380-3-60	0	1	0	0	0	0	0	82	21	1	0	1	0	1	0	0	0	0	1	0	0	0	0	0	0	82	21	1	0	1	0	1	0	0	0	
	460-3-60	0	1	0	0	0	0	0	68	14	0	1	1	1	0	0	0	0	0	1	0	0	0	0	0	0	68	14	0	1	1	1	0	0	0	0	
	380/415-3-50	0	1	0	0	0	0	0	86	23	1	1	1	0	1	0	0	0	0	1	0	0	0	0	0	0	86	23	1	1	1	0	1	0	0	0	
30HXC086	575-3-60	0	1	0	0	0	0	0	66	13	1	0	1	1	0	0	0	0	0	1	0	0	0	0	0	54	7	1	1	1	0	0	0	0	0		
	380-3-60	0	1	0	0	0	0	0	100	30	0	1	1	1	1	0	0	0	0	1	0	0	0	0	0	82	21	1	0	1	0	1	0	0	0		
	460-3-60	0	1	0	0	0	0	0	82	21	1	0	1	0	1	0	0	0	0	1	0	0	0	0	0	68	14	0	1	1	1	0	0	0	0		
	380/415-3-50	0	1	0	0	0	0	0	104	32	0	0	0	0	0	1	0	0	0	1	0	0	0	0	0	86	23	1	1	1	0	1	0	0	0		
30HXC096	575-3-60	0	1	0	0	0	0	0	80	20	0	0	1	0	1	0	0	0	0	1	0	0	0	0	0	54	7	1	1	1	0	0	0	0	0		
	380-3-60	0	1	0	0	0	0	0	122	41	1	0	0	1	0	1	0	0	0	1	0	0	0	0	0	82	21	1	0	1	0	1	0	0	0		
	460-3-60	0	1	0	0	0	0	0	102	31	1	1	1	1	1	0	0	0	0	1	0	0	0	0	0	68	14	0	1	1	1	0	0	0	0		
	380/415-3-50	0	1	0	0	0	0	0	126	43	1	1	0	1	0	1	0	0	0	1	0	0	0	0	0	86	23	1	1	1	0	1	0	0	0		
30HXC106	575-3-60	0	1	0	0	0	0	0	98	29	1	0	1	1	1	0	0	0	0	1	0	0	0	0	0	54	7	1	1	1	0	0	0	0	0		
	380-3-60	0	1	0	0	0	0	0	148	54	0	1	1	0	1	1	0	0	0	1	0	0	0	0	0	82	21	1	0	1	0	1	0	0	0		
	460-3-60	0	1	0	0	0	0	0	122	41	1	0	0	1	0	1	0	0	0	1	0	0	0	0	0	68	14	0	1	1	1	0	0	0	0		
	380/415-3-50	0	1	0	1	0	0	0	152	56	0	0	0	1	1	1	0	0	0	1	0	0	0	0	0	86	23	1	1	1	0	1	0	0	0		
30HXC116	575-3-60	0	1	0	0	0	0	0	98	29	1	0	1	1	1	0	0	0	0	1	0	0	0	0	0	66	13	1	0	1	1	0	0	0	0		
	380-3-60	0	1	0	0	0	0	0	148	54	0	1	1	0	1	1	0	0	0	1	0	0	0	0	0	100	30	0	1	1	1	1	0	0	0		
	460-3-60	0	1	0	0	0	0	0	122	41	1	0	0	1	0	1	0	0	0	1	0	0	0	0	0	82	21	1	0	1	0	1	0	0	0		
	380/415-3-50	0	1	0	1	0	0	0	152	56	0	0	0	1	1	1	0	0	0	1	0	0	0	0	0	104	32	0	0	0	0	0	1	0	0	0	
30HXC126	575-3-60	0	1	0	0	0	0	0	98	29	1	0	1	1	1	0	0	0	0	1	0	0	0	0	0	80	20	0	0	1	0	1	0	0	0		
	380-3-60	0	1	0	0	0	0	0	148	54	0	1	1	0	1	1	0	0	0	1	0	0	0	0	0	122	41	1	0	0	1	0	1	0	0		
	460-3-60	0	1	0	0	0	0	0	122	41	1	0	0	1	0	1	0	0	0	1	0	0	0	0	0	102	31	1	1	1	1	1	0	0	0		
	380/415-3-50	0	1	0	1	0	0	0	152	56	0	0	0	1	1	1	0	0	0	1	0	0	0	0	0	126	43	1	1	0	1	0	1	0	0		
30HXC136	575-3-60	0	1	0	0	0	0	0	118	39	1	1	1	0	0	1	0	0	0	1	0	0	0	0	0	80	20	0	0	1	0	1	0	0	0		
	380-3-60	0	1	0	1	0	0	0	178	69	1	0	1	0	0	0	1	0	0	1	0	0	0	0	0	122	41	1	0	0	1	0	1	0	0		
	460-3-60	0	1	0	0	0	0	0	146	53	1	0	1	0	1	1	0	0	0	1	0	0	0	0	0	102	31	1	1	1	1	1	0	0	0		
	380/415-3-50	0	1	0	1	0	0	0	184	72	0	0	0	1	0	0	1	0	0	0	1	0	0	0	0	126	43	1	1	0	1	0	1	0	0		
30HXC146	575-3-60	0	1	0	0	0	0	0	118	39	1	1	1	0	0	1	0	0	0	1	0	0	0	0	0	98	29	1	0	1	1	1	0	0	0		
	380-3-60	0	1	0	1	0	0	0	178	69	1	0	1	0	0	0	1	0	0	1	0	0	0	0	0	148	54	0	1	1	0	1	1	0	0		
	460-3-60	0	1	0	0	0	0	0	146	53	1	0	1	0	1	1	0	0	0	1	0	0	0	0	0	122	41	1	0	0	1	0	1	0	0		
	380/415-3-50	0	1	0	1	0	0	0	184	72	0	0	0	1	0	0	1	0	0	0	1	0	0	0	0	152	56	0	0	0	1	1	1	0	0		
30HXC161	575-3-60	0	1	0	0	0	0	0	128	44	0	0	1	1	0	1	0	0	0	1	0	0	0	0	0	88	24	0	0	0	1	1	0	0	0		
	380-3-60	0	1	0	1	0	0	0	194	77	1	0	1	1	0	0	1	0	0	0	1	0	0	0	0	134	47	1	1	1	1	0	1	0	0		
	460-3-60	0	1	0	1	0	0	0	160	60	0	0	1	1	1	1	0	0	0	0	1	0	0	0	0	110	35	1	1	0	0	0	1	0	0		
	380/415-3-50	0	1	0	1	0	0	0	200	80	0	0	0	0	1	0	1	0	0	0	1	0	0	0	0	136	48	0	0	0	0	1	1	0	0		
30HXC171	575-3-60	0	1	0	0	0	0	0	106	33	1	0	0	0	0	1	0	0	0	1	0	0	0	0	0	128	44	0	0	1	1	0	1	0	0		
	380-3-60	0	1	0	1	0	0	0	162	61	1	0	1	1	1	1	0	0	0	1	0	0	1	0	0	194	77	1	0	1	1	0	0	0	1	0	
	460-3-60	0	1	0	0	0	0	0	134	47	1	1	1	1	0	1	0	0	0	1	0	1	0	0	0	160	60	0	0	1	1	1	1	0	0		
	380/415-3-50	0	1	0	1	0	0	0	164	62	0	1	1	1	1	1	0	0	0	0	1	0	1	0	0	200	80	0	0	0	0	1	0	1	0	0	
30HXC186	575-3-60	0	1	0	0	0	0	0	128	44	0	0	1	1	0	1	0	0	0	1	0	0	0	0	0	128	44	0	0	1	1	0	1	0	0		
	380-3-60	0	1	0	1	0	0	0	194	77	1	0	1	1	0	0	1	0	0	0	1	0	1	0	0	194	77	1	0	1	1	0	0	0	1	0	
	460-3-60	0	1	0	1	0	0	0	160	60	0	0	1	1	1	1	0	0	0	0	1	0	1	0	0	160	60	0	0	1	1	1	1	0	0		
	380/415-3-50	0	1	0	1	0	0	0	200	80	0	0	0	0	1	0	1	0	0	0	1	0	1	0	0	200	80	0	0	0	0	1	0	1	0	0	

* XL starter not available on 230-3-60, 208/230-3-60, or 230-3-50 units.

APPENDIX A — COMPRESSOR MUST TRIP AMP (MTA) SETTINGS (cont)

MTA Setting for 30HXA,HXC076-186 with Wye-Delta Starter (1 = ON, 0 = OFF)

UNIT	V-PH-HZ	COMPRESSOR A1																COMPRESSOR B1																				
		S1 Setting								MTA	S2 Value	S2 Setting								S1 Setting								MTA	S2 Value	S2 Setting								
		1	2	3	4	5	6	7	8			1	2	3	4	5	6	7	8	1	2	3	4	5	6	7	8			1	2	3	4	5	6	7	8	
30HXA076	575-3-60	1	1	0	0	0	0	0	80	20	0	0	1	0	1	0	0	0	1	1	0	0	0	0	0	0	80	20	0	0	1	0	1	0	1	0	0	0
	380-3-60	1	1	0	0	0	0	0	122	41	1	0	0	1	0	1	0	0	1	1	0	0	0	0	0	0	122	41	1	0	0	1	0	1	0	1	0	0
	230-3-60	1	1	0	1	0	0	0	202	81	1	0	0	0	1	0	1	0	1	1	0	1	0	0	0	0	202	81	1	0	0	0	1	0	1	0	1	0
	208/230-3-60	1	1	0	1	0	0	0	224	92	0	0	1	1	1	0	1	0	1	1	0	1	0	0	0	0	224	92	0	0	1	1	1	1	0	1	0	1
	460-3-60	1	1	0	0	0	0	0	100	30	0	1	1	1	1	0	0	0	1	1	0	0	0	0	0	0	100	30	0	1	1	1	1	0	0	0	0	
	230-3-50	1	1	0	1	0	0	0	210	85	1	0	1	0	1	0	1	0	1	1	0	1	0	0	0	0	210	85	1	0	1	0	1	0	1	0	1	0
	380/415-3-50	1	1	0	0	0	0	0	126	43	1	1	0	1	0	1	0	0	1	1	0	0	0	0	0	0	126	43	1	1	0	1	0	1	0	1	0	0
30HXA086	575-3-60	1	1	0	0	0	0	0	96	28	0	0	1	1	1	0	0	0	1	1	0	0	0	0	0	80	20	0	0	1	0	1	0	1	0	0	0	
	380-3-60	1	1	0	0	0	0	0	146	53	1	0	1	0	1	1	0	0	1	1	0	0	0	0	0	122	41	1	0	0	1	0	1	0	1	0	0	
	230-3-60	1	1	0	1	0	0	0	242	101	1	0	1	0	0	1	1	0	1	1	0	1	0	0	0	202	81	1	0	0	0	1	0	1	0	1	0	
	208/230-3-60	1	1	0	1	0	0	0	268	114	0	1	0	0	1	1	1	0	1	1	0	1	0	0	0	224	92	0	0	1	1	1	1	0	1	0	1	
	460-3-60	1	1	0	0	0	0	0	120	40	0	0	0	1	0	1	0	0	1	1	0	0	0	0	0	100	30	0	1	1	1	1	0	0	0	0	0	
	230-3-50	1	1	0	1	0	0	0	254	107	1	1	0	1	0	1	1	0	1	1	0	1	0	0	0	210	85	1	0	1	0	1	0	1	0	1	0	
	380/415-3-50	1	1	0	1	0	0	0	154	57	1	0	0	1	1	1	0	0	1	1	0	0	0	0	0	126	43	1	1	0	1	0	1	0	1	0	0	
30HXA096	575-3-60	1	1	0	0	0	0	0	118	39	1	1	1	0	0	1	0	0	1	1	0	0	0	0	0	80	20	0	0	1	0	1	0	1	0	0	0	
	380-3-60	1	1	0	1	0	0	0	178	69	1	0	1	0	0	1	0	0	1	1	0	0	0	0	0	122	41	1	0	0	1	0	1	0	1	0	0	
	230-3-60	1	1	0	1	0	0	0	294	127	1	1	1	1	1	1	0	1	1	0	1	0	0	0	0	202	81	1	0	0	0	1	0	1	0	1	0	
	208/230-3-60	1	1	0	0	1	0	0	326	19	1	1	0	0	1	0	0	0	1	1	0	1	0	0	0	224	92	0	0	1	1	1	1	0	1	0	0	
	460-3-60	1	1	0	0	0	0	0	146	53	1	0	1	0	1	1	0	0	1	1	0	0	0	0	0	100	30	0	1	1	1	1	0	0	0	0	0	
	230-3-50	1	1	0	0	1	0	0	306	14	0	1	1	1	0	0	0	0	0	1	1	0	0	0	0	210	85	1	0	1	0	1	0	1	0	1	0	
	380/415-3-50	1	1	0	1	0	0	0	186	73	1	0	0	1	0	0	1	0	1	1	0	0	0	0	0	126	43	1	1	0	1	0	1	0	1	0	0	
30HXA106	575-3-60	1	1	0	0	0	0	0	142	51	1	1	0	0	1	1	0	0	1	1	0	0	0	0	0	80	20	0	0	1	0	1	0	1	0	0	0	
	380-3-60	1	1	0	1	0	0	0	216	88	0	0	0	1	1	0	1	0	1	1	0	0	0	0	0	122	41	1	0	0	1	0	1	0	1	0	0	
	230-3-60	1	1	0	0	1	0	0	358	27	1	1	0	1	1	0	0	0	1	1	0	1	0	0	0	202	81	1	0	0	0	1	0	1	0	1	0	
	208/230-3-60	1	1	0	0	1	0	0	398	37	1	0	1	0	0	1	0	0	1	1	0	1	0	0	0	224	92	0	0	1	1	1	1	0	1	0	1	
	460-3-60	1	1	0	1	0	0	0	178	69	1	0	1	0	0	0	1	0	1	1	0	0	0	0	0	100	30	0	1	1	1	1	0	0	0	0		
	230-3-50	1	1	0	0	1	0	0	374	31	1	1	1	1	1	0	0	0	1	1	0	1	0	0	0	210	85	1	0	1	0	1	0	1	0	1	0	
	380/415-3-50	1	1	0	1	0	0	0	226	93	1	0	1	1	1	0	1	0	1	1	0	0	0	0	0	126	43	1	1	0	1	0	1	0	1	0	0	
30HXA116	575-3-60	1	1	0	0	0	0	0	142	51	1	1	0	0	1	1	0	0	1	1	0	0	0	0	0	96	28	0	0	1	1	1	0	0	0	0	0	
	380-3-60	1	1	0	1	0	0	0	216	88	0	0	0	1	1	0	1	0	1	1	0	0	0	0	0	146	53	1	0	1	0	1	1	0	0	0	0	
	230-3-60	1	1	0	0	1	0	0	358	27	1	1	0	1	1	0	0	0	1	1	0	1	0	0	0	242	101	1	0	1	0	0	0	1	1	0	0	
	208/230-3-60	1	1	0	0	1	0	0	398	37	1	0	1	0	0	1	0	0	1	1	0	1	0	0	0	268	114	0	1	0	0	1	1	1	0	0	0	
	460-3-60	1	1	0	1	0	0	0	178	69	1	0	1	0	0	0	1	0	1	1	0	0	0	0	0	120	40	0	0	0	1	0	1	0	0	0	0	
	230-3-50	1	1	0	0	1	0	0	374	31	1	1	1	1	1	0	0	0	1	1	0	1	0	0	0	254	107	1	1	0	1	0	1	0	1	1	0	
	380/415-3-50	1	1	0	1	0	0	0	226	93	1	0	1	1	1	0	1	0	1	1	0	1	0	0	0	154	57	1	0	0	1	1	1	0	0	0	0	
30HXA126	575-3-60	1	1	0	0	0	0	0	142	51	1	1	0	0	1	1	0	0	1	1	0	0	0	0	0	118	39	1	1	1	0	0	1	0	0	0	0	
	380-3-60	1	1	0	1	0	0	0	216	88	0	0	0	1	1	0	1	0	1	1	0	1	0	0	0	178	69	1	0	1	0	0	0	1	0	0	0	
	230-3-60	1	1	0	0	1	0	0	358	27	1	1	0	1	1	0	0	0	1	1	0	1	0	0	0	294	127	1	1	1	1	1	1	1	0	0	0	
	208/230-3-60	1	1	0	0	1	0	0	398	37	1	0	1	0	0	1	0	0	1	1	0	0	1	0	0	0	326	19	1	1	0	0	1	0	0	0	0	
	460-3-60	1	1	0	1	0	0	0	178	69	1	0	1	0	0	0	1	0	1	1	0	0	0	0	0	146	53	1	0	1	0	1	1	0	0	0	0	
	230-3-50	1	1	0	0	1	0	0	374	31	1	1	1	1	1	0	0	0	1	1	0	0	1	0	0	306	14	0	1	1	1	1	0	0	0	0	0	
	380/415-3-50	1	1	0	1	0	0	0	226	93	1	0	1	1	1	0	1	0	1	1	0	1	0	0	0	186	73	1	0	0	1	0	0	1	0	0	0	
30HXA136	575-3-60	1	1	0	1	0	0	0	174	67	1	1	0	0	0	0	1	0	1	1	0	0	0	0	0	118	39	1	1	1	0	0	1	0	0	0	0	
	380-3-60	1	1	0	1	0	0	0	264	112	0	0	0	0	1	1	0	1	1	0	1	0	0	0	0	178	69	1	0	1	0	0	0	0	0	0	0	
	230-3-60	1	1	0	0	1	0	0	434	46	0	1	1	1	0	1	0	0	1	1	0	1	0	0	0	294	127	1	1	1	1	1	1	1	0	0	0	
	208/230-3-60	1	1	0	0	1	0	0	482	58	0	1	0	1	1	1	0	0	1	1	0	0	1	0	0	0	326	19	1	1	0	0	1	0	0	0	0	0
	460-3-60	1	1	0	1	0	0	0	218	89	1	0	0	1	1	0	1	0	1	1	0	0	0	0	0	146	53	1	0	1	0	1	0	1	1	0	0	0
	230-3-50	1	1	0	0	1	0	0	458	52	0	0	1	0	1	1	0	0	1	1	0	0	1	0	0	306	14	0	1	1	1	0	0	0	0	0	0	
	380/415-3-50	1	1	0	1	0	0	0	278	119	1	1	1	0	1	1																						

APPENDIX A — COMPRESSOR MUST TRIP AMP (MTA) SETTINGS (cont)
MTA Setting for 30HXA,HXC076-186 with Wye-Delta Starter (1 = ON, 0 = OFF) (cont)

UNIT	V-PH-HZ	COMPRESSOR A1																COMPRESSOR B1																					
		S1 Setting								MTA	S2 Value	S2 Setting								S1 Setting								MTA	S2 Value	S2 Setting									
		1	2	3	4	5	6	7	8			1	2	3	4	5	6	7	8	1	2	3	4	5	6	7	8			1	2	3	4	5	6	7	8		
30HXA146	575-3-60	1	1	0	1	0	0	0	0	174	67	1	1	0	0	0	1	0	1	1	0	0	0	0	0	0	142	51	1	1	0	0	1	1	0	0			
	380-3-60	1	1	0	1	0	0	0	0	264	112	0	0	0	0	1	1	1	0	1	1	0	1	0	0	0	216	88	0	0	0	1	1	0	1	0			
	230-3-60	1	1	0	0	1	0	0	0	434	46	0	1	1	1	0	1	0	0	1	1	0	0	1	0	0	0	358	27	1	1	0	1	1	0	0	0		
	208/230-3-60	1	1	0	0	1	0	0	0	482	58	0	1	0	1	1	1	0	0	1	1	0	0	1	0	0	0	398	37	1	0	1	0	0	1	0	0		
	460-3-60	1	1	0	1	0	0	0	0	218	89	1	0	0	1	1	0	1	0	1	1	0	1	0	0	0	0	178	69	1	0	1	0	0	0	1	0		
	230-3-50	1	1	0	0	1	0	0	0	458	52	0	0	1	0	1	1	0	0	1	1	0	0	1	0	0	0	374	31	1	1	1	1	1	0	0	0		
	380/415-3-50	1	1	0	1	0	0	0	0	278	119	1	1	1	0	1	1	1	0	1	1	0	1	0	0	0	0	226	93	1	0	1	1	1	1	0	1	0	
30HXA161	575-3-60	1	1	0	1	0	0	0	0	196	78	0	1	1	1	0	0	0	1	0	1	0	0	0	0	0	132	46	0	1	1	1	0	1	0	0	0		
	380-3-60	1	1	0	1	0	0	0	0	298	129	1	0	0	0	0	0	0	1	1	1	0	1	0	0	0	200	80	0	0	0	0	1	0	1	0	0		
	230-3-60	1	1	0	0	1	0	0	0	490	60	0	0	1	1	1	1	0	0	1	1	0	0	1	0	0	0	330	20	0	0	1	0	1	0	0	0	0	
	208/230-3-60	1	1	0	0	1	0	0	0	542	73	1	0	0	1	0	0	1	0	1	1	0	0	1	0	0	0	366	29	1	0	1	1	1	0	0	0	0	
	460-3-60	1	1	0	1	0	0	0	0	246	103	1	1	1	0	0	1	1	0	1	1	0	1	0	0	0	0	166	63	1	1	1	1	1	1	0	0	0	
	230-3-50	1	1	0	0	1	0	0	0	518	67	1	1	0	0	0	0	1	0	1	1	0	0	1	0	0	0	342	23	1	1	1	0	1	0	0	0	0	
	380/415-3-50	1	1	0	0	1	0	0	0	310	15	1	1	1	1	0	0	0	0	1	1	0	1	0	0	0	0	206	83	1	1	0	0	1	0	1	0	0	
30HXA171	575-3-60	1	1	0	1	0	0	0	0	160	60	0	0	1	1	1	1	0	0	1	1	0	1	0	0	0	0	196	78	0	1	1	1	0	0	1	0	0	
	380-3-60	1	1	0	1	0	0	0	0	244	102	0	1	1	0	0	1	1	0	1	1	0	1	0	0	0	0	298	129	1	0	0	0	0	0	0	0	1	0
	230-3-60	1	1	0	0	1	0	0	0	402	38	0	1	1	0	0	1	0	0	1	1	0	0	1	0	0	0	490	60	0	0	1	1	1	1	0	0	0	
	208/230-3-60	1	1	0	0	1	0	0	0	446	49	1	0	0	0	1	1	0	0	1	1	0	0	1	0	0	0	542	73	1	0	0	1	0	0	1	0	0	
	460-3-60	1	1	0	1	0	0	0	0	202	81	1	0	0	0	1	0	1	0	1	1	0	1	0	0	0	0	246	103	1	1	1	1	0	0	1	1	0	
	230-3-50	1	1	0	0	1	0	0	0	414	41	1	0	0	1	0	1	0	0	1	1	0	0	1	0	0	0	518	67	1	1	0	0	0	0	1	0	0	
	380/415-3-50	1	1	0	1	0	0	0	0	252	106	0	1	0	1	0	1	1	0	1	1	0	0	1	0	0	0	310	15	1	1	1	1	0	0	0	0	0	
30HXA186	575-3-60	1	1	0	1	0	0	0	0	196	78	0	1	1	1	0	0	0	1	1	0	1	0	0	0	0	196	78	0	1	1	1	0	0	0	1	0	0	
	380-3-60	1	1	0	1	0	0	0	0	298	129	1	0	0	0	0	0	0	1	1	0	1	0	0	0	0	298	129	1	0	0	0	0	0	0	0	0	1	
	230-3-60	1	1	0	0	1	0	0	0	490	60	0	0	1	1	1	1	0	0	1	1	0	0	1	0	0	0	490	60	0	0	1	1	1	1	0	0	0	
	208/230-3-60	1	1	0	0	1	0	0	0	542	73	1	0	0	1	0	0	1	0	1	1	0	0	1	0	0	0	542	73	1	0	0	1	0	0	1	0	0	0
	460-3-60	1	1	0	1	0	0	0	0	246	103	1	1	1	0	0	1	1	0	1	1	0	1	0	0	0	0	246	103	1	1	1	0	0	0	1	1	0	0
	230-3-50	1	1	0	0	1	0	0	0	518	67	1	1	0	0	0	0	1	0	1	1	0	0	1	0	0	0	518	67	1	1	0	0	0	0	1	0	0	
	380/415-3-50	1	1	0	0	1	0	0	0	310	15	1	1	1	1	0	0	0	0	1	1	0	0	1	0	0	0	310	15	1	1	1	1	0	0	0	0	0	
30HXC076	575-3-60	1	1	0	0	0	0	0	0	54	7	1	1	1	0	0	0	0	0	1	1	0	0	0	0	0	0	54	7	1	1	1	0	0	0	0	0	0	
	380-3-60	1	1	0	0	0	0	0	0	82	21	1	0	1	0	1	0	0	0	1	1	0	0	0	0	0	0	82	21	1	0	1	0	1	0	0	0	0	
	230-3-60	1	1	0	0	0	0	0	0	136	48	0	0	0	0	1	1	0	0	1	1	0	0	0	0	0	136	48	0	0	0	0	1	1	0	0	0	0	
	208/230-3-60	1	1	0	1	0	0	0	0	152	56	0	0	0	1	1	1	0	0	1	1	0	1	0	0	0	0	152	56	0	0	0	1	1	1	0	0	0	
	460-3-60	1	1	0	0	0	0	0	0	68	14	0	1	1	1	0	0	0	0	1	1	0	0	0	0	0	0	68	14	0	1	1	1	0	0	0	0	0	
	230-3-50	1	1	0	0	0	0	0	0	142	51	1	1	0	0	1	1	0	0	1	1	0	0	0	0	0	0	142	51	1	1	0	0	1	1	0	0	0	0
	380/415-3-50	1	1	0	0	0	0	0	0	86	23	1	1	1	0	1	0	0	0	1	1	0	0	0	0	0	0	86	23	1	1	1	0	1	0	0	0	0	
30HXC086	575-3-60	1	1	0	0	0	0	0	0	66	13	1	0	1	1	0	0	0	0	1	1	0	0	0	0	0	0	54	7	1	1	1	0	0	0	0	0	0	
	380-3-60	1	1	0	0	0	0	0	0	100	30	0	1	1	1	1	0	0	0	1	1	0	0	0	0	0	0	82	21	1	0	1	0	1	0	0	0	0	
	230-3-60	1	1	0	1	0	0	0	0	166	63	1	1	1	1	1	1	0	0	1	1	0	0	0	0	0	0	136	48	0	0	0	0	1	1	0	0	0	0
	208/230-3-60	1	1	0	1	0	0	0	0	184	72	0	0	0	1	0	0	1	0	1	1	0	1	0	0	0	0	152	56	0	0	0	1	1	1	0	0	0	
	460-3-60	1	1	0	0	0	0	0	0	82	21	1	0	1	0	1	0	0	0	1	1	0	0	0	0	0	0	68	14	0	1	1	1	0	0	0	0	0	
	230-3-50	1	1	0	1	0	0	0	0	174	67	1	1	0	0	0	0	1	0	1	1	0	0	0	0	0	0	142	51	1	1	0	0	1	1	0	0	0	0
	380/415-3-50	1	1	0	0	0	0	0	0	104	32	0	0	0	0	0	1	0	0	1	1	0	0	0	0	0	0	86	23	1	1	1	0	1	0	0	0	0	
30HXC096	575-3-60	1	1	0	0	0	0	0	0	80	20	0	0	1	0	1	0	0	0	1	1	0	0	0	0	0	0	54	7	1	1	1	0	0	0	0	0	0	
	380-3-60	1	1	0	0	0	0	0	0	122	41	1	0	0	1	0	1	0	0	1	1	0	0	0	0	0	0	82	21	1	0	1	0	1	0	0	0	0	
	230-3-60	1	1	0	1	0	0	0	0	202	81	1	0	0	0	1	0	1	0	1	1	0	0	0	0	0	136	48	0	0	0	0	1	1	0	0	0	0	
	208/230-3-60	1	1	0	1	0	0	0	0	224	92	0	0	1	1	1	0	0	1	1	0	1	0	0	0	0	0	152	56	0	0	0	1	1	1	0	0	0	
	460-3-60	1	1	0	0	0	0	0	0	102	31	1	1	1	1	0	0	0	0	1	1	0	0	0	0	0	0	68	14	0	1	1	1	0	0	0	0	0	
	230-3-50	1	1	0	1	0	0	0	0	210	85	1	0	1	0	1	0	1	0	1	1	0	0	0	0	0	0	142</											

APPENDIX A — COMPRESSOR MUST TRIP AMP (MTA) SETTINGS (cont)
MTA Setting for 30HXA,HXC076-186 with Wye-Delta Starter (1 = ON, 0 = OFF) (cont)

UNIT	V-PH-HZ	COMPRESSOR A1																COMPRESSOR B1																			
		S1 Setting								MTA	S2 Value	S2 Setting								S1 Setting								MTA	S2 Value	S2 Setting							
		1	2	3	4	5	6	7	8			1	2	3	4	5	6	7	8	1	2	3	4	5	6	7	8			1	2	3	4	5	6	7	8
30HXC106	575-3-60	1	1	0	0	0	0	0	98	29	1	0	1	1	1	0	0	0	1	1	0	0	0	0	0	54	7	1	1	1	0	0	0	0	0		
	380-3-60	1	1	0	0	0	0	0	148	54	0	1	1	0	1	1	0	0	1	1	0	0	0	0	0	82	21	1	0	1	0	1	0	0			
	230-3-60	1	1	0	1	0	0	0	246	103	1	1	1	0	0	1	1	0	1	1	0	0	0	0	0	136	48	0	0	0	0	1	1	0	0		
	208/230-3-60	1	1	0	1	0	0	0	272	116	0	0	1	0	1	1	1	0	1	1	0	1	0	0	0	152	56	0	0	0	1	1	1	0	0		
	460-3-60	1	1	0	0	0	0	0	122	41	1	0	0	1	0	1	0	0	1	1	0	0	0	0	0	68	14	0	1	1	1	0	0	0	0		
	230-3-50	1	1	0	1	0	0	0	252	106	0	1	0	1	0	1	1	0	1	1	0	0	0	0	0	142	51	1	1	0	0	1	1	0	0		
	380/415-3-50	1	1	0	1	0	0	0	152	56	0	0	0	1	1	1	0	0	1	1	0	0	0	0	0	86	23	1	1	1	0	1	0	0	0		
30HXC116	575-3-60	1	1	0	0	0	0	0	98	29	1	0	1	1	1	0	0	0	1	1	0	0	0	0	0	66	13	1	0	1	1	0	0	0	0		
	380-3-60	1	1	0	0	0	0	0	148	54	0	1	1	0	1	1	0	0	1	1	0	0	0	0	0	100	30	0	1	1	1	1	0	0	0		
	230-3-60	1	1	0	1	0	0	0	246	103	1	1	1	0	0	1	1	0	1	1	0	1	0	0	0	166	63	1	1	1	1	1	1	0	0		
	208/230-3-60	1	1	0	1	0	0	0	272	116	0	0	1	0	1	1	1	0	1	1	0	1	0	0	0	184	72	0	0	0	1	0	0	1	0		
	460-3-60	1	1	0	0	0	0	0	122	41	1	0	0	1	0	1	0	0	1	1	0	0	0	0	0	82	21	1	0	1	0	1	0	0	0		
	230-3-50	1	1	0	1	0	0	0	252	106	0	1	0	1	0	1	1	0	1	1	0	1	0	0	0	174	67	1	1	0	0	0	0	1	0		
	380/415-3-50	1	1	0	1	0	0	0	152	56	0	0	0	1	1	1	0	0	1	1	0	0	0	0	0	104	32	0	0	0	0	0	1	0	0		
30HXC126	575-3-60	1	1	0	0	0	0	0	98	29	1	0	1	1	1	0	0	0	1	1	0	0	0	0	0	80	20	0	0	1	0	1	0	0	0		
	380-3-60	1	1	0	0	0	0	0	148	54	0	1	1	0	1	1	0	0	1	1	0	0	0	0	0	122	41	1	0	0	1	0	1	0	0		
	230-3-60	1	1	0	1	0	0	0	246	103	1	1	1	0	0	1	1	0	1	1	0	1	0	0	0	202	81	1	0	0	0	1	0	1	0		
	208/230-3-60	1	1	0	1	0	0	0	272	116	0	0	1	0	1	1	1	0	1	1	0	1	0	0	0	224	92	0	0	1	1	1	0	1	0		
	460-3-60	1	1	0	0	0	0	0	122	41	1	0	0	1	0	1	0	0	1	1	0	0	0	0	0	102	31	1	1	1	1	1	0	0	0		
	230-3-50	1	1	0	1	0	0	0	252	106	0	1	0	1	0	1	1	0	1	1	0	1	0	0	0	210	85	1	0	1	0	1	0	1	0		
	380/415-3-50	1	1	0	1	0	0	0	152	56	0	0	0	1	1	1	0	0	1	1	0	0	0	0	0	126	43	1	1	0	1	0	1	0	0		
30HXC136	575-3-60	1	1	0	0	0	0	0	118	39	1	1	1	0	0	1	0	0	1	1	0	0	0	0	0	80	20	0	0	1	0	1	0	0	0		
	380-3-60	1	1	0	1	0	0	0	178	69	1	0	1	0	0	0	1	0	1	1	0	0	0	0	0	122	41	1	0	0	1	0	1	0	0		
	230-3-60	1	1	0	1	0	0	0	294	127	1	1	1	1	1	1	0	1	1	0	1	0	0	0	0	202	81	1	0	0	0	1	0	1	0		
	208/230-3-60	1	1	0	0	1	0	0	326	19	1	1	0	0	1	0	0	0	1	1	0	1	0	0	0	224	92	0	0	1	1	1	0	1	0		
	460-3-60	1	1	0	0	0	0	0	146	53	1	0	1	0	1	1	0	0	1	1	0	0	0	0	0	102	31	1	1	1	1	1	0	0	0		
	230-3-50	1	1	0	0	1	0	0	306	14	0	1	1	1	0	0	0	0	1	1	0	1	0	0	0	210	85	1	0	1	0	1	0	1	0		
	380/415-3-50	1	1	0	1	0	0	0	184	72	0	0	0	1	0	0	1	0	1	1	0	0	0	0	0	126	43	1	1	0	1	0	1	0	0		
30HXC146	575-3-60	1	1	0	0	0	0	0	118	39	1	1	1	0	0	1	0	0	1	1	0	0	0	0	0	98	29	1	0	1	1	1	0	0	0		
	380-3-60	1	1	0	1	0	0	0	178	69	1	0	1	0	0	0	1	0	1	1	0	0	0	0	0	148	54	0	1	1	0	1	1	0	0		
	230-3-60	1	1	0	1	0	0	0	294	127	1	1	1	1	1	1	0	1	1	0	1	0	0	0	0	244	102	0	1	1	0	0	1	1	0		
	208/230-3-60	1	1	0	0	1	0	0	326	19	1	1	0	0	1	0	0	0	1	1	0	1	0	0	0	272	116	0	0	1	0	1	1	1	0		
	460-3-60	1	1	0	0	0	0	0	146	53	1	0	1	0	1	1	0	0	1	1	0	0	0	0	0	122	41	1	0	0	1	0	1	0	0		
	230-3-50	1	1	0	0	1	0	0	306	14	0	1	1	1	0	0	0	0	1	1	0	1	0	0	0	252	106	0	1	0	1	0	1	1	0		
	380/415-3-50	1	1	0	1	0	0	0	184	72	0	0	0	1	0	0	1	0	1	1	0	1	0	0	0	152	56	0	0	0	1	1	1	0	0		
30HXC161	575-3-60	1	1	0	0	0	0	0	128	44	0	0	1	1	0	1	0	0	1	1	0	0	0	0	0	88	24	0	0	0	1	1	0	0	0		
	380-3-60	1	1	0	1	0	0	0	194	77	1	0	1	1	0	0	1	0	1	1	0	0	0	0	0	134	47	1	1	1	1	0	1	0	0		
	230-3-60	1	1	0	0	1	0	0	318	17	1	0	0	0	1	0	0	0	1	1	0	1	0	0	0	220	90	0	1	0	1	1	0	1	0		
	208/230-3-60	1	1	0	0	1	0	0	354	26	0	1	0	1	1	0	0	0	1	1	0	1	0	0	0	244	102	0	1	1	0	0	1	1	0		
	460-3-60	1	1	0	1	0	0	0	160	60	0	0	1	1	1	1	0	0	1	1	0	0	0	0	0	110	35	1	1	0	0	0	1	0	0		
	230-3-50	1	1	0	0	1	0	0	330	20	0	0	1	0	1	0	0	0	0	1	1	0	1	0	0	0	226	93	1	0	1	1	1	0	1	0	
	380/415-3-50	1	1	0	1	0	0	0	200	80	0	0	0	0	1	0	1	0	1	1	0	0	0	0	0	136	48	0	0	0	0	1	1	0	0		
30HXC171	575-3-60	1	1	0	0	0	0	0	106	33	1	0	0	0	0	1	0	0	1	1	0	0	0	0	0	128	44	0	0	1	1	0	1	0	0		
	380-3-60	1	1	0	1	0	0	0	162	61	1	0	1	1	1	1	0	0	1	1	0	1	0	0	0	194	77	1	0	1	1	0	0	1	0		
	230-3-60	1	1	0	1	0	0	0	266	113	1	0	0	0	1	1	1	0	1	1	0	0	1	0	0	318	17	1	0	0	0	1	0	0	0		
	208/230-3-60	1	1	0	1	0	0	0	296	128	0	0	0	0	0	0	0	1	1	0	0	1	0	0	0	354	26	0	1	0	1	1	0	0	0		
	460-3-60	1	1	0	0	0	0	0	134	47	1	1	1	1	0	1	0	0	0	1	1	0	1	0	0	0	160	60	0	0	1	1	1	1	0	0	
	230-3-50	1	1	0	1	0	0	0	272	116	0	0	1	0	1	1	1	0	1	1	0	0	1	0	0	0	330	20	0	0	1	0	1	0	0	0	
	380/415-3-50	1	1	0	1	0	0	0	164	62	0	1	1	1	1	1	0	0	1	1	0	1	0	0	0	200	80	0	0	0	0	1	0	1	0		
30HXC186	575-3-60	1	1	0	0	0	0	0	128	44	0	0	1	1	0	1	0	0	1	1	0	0	0	0	0	128	44	0	0	1	1	0	1	0	0		
	380-3-60	1	1	0	1	0	0	0	194	77	1	0	1	1	0	0	1	0	1	1	0	1	0	0	0	194	77	1	0	1	1	0	0	1	0		
	230-3-60	1	1	0	0	1																															

APPENDIX A — COMPRESSOR MUST TRIP AMP (MTA) SETTINGS (cont)

MTA Setting for 30HXA,HXC206-271 with XL Starter* (1 = ON, 0 = OFF)

UNIT	VPH-HZ	COMPRESSOR A1														COMPRESSOR A2														COMPRESSOR B1																										
		S1 Setting							MTA	S2 Value	S2 Setting							S1 Setting							MTA	S2 Value	S2 Setting							S1 Setting							MTA	S2 Value	S2 Setting													
		1	2	3	4	5	6	7			8	1	2	3	4	5	6	7	8	1	2	3	4	5			6	7	8	1	2	3	4	5	6	7	8	1	2	3			4	5	6	7	8	1	2	3	4	5	6	7	8	
30HXA 206	575-3-60	0	1	0	1	0	0	0	0	160	60	0	0	1	1	1	1	0	0	0	1	0	0	0	0	0	0	0	90	25	1	0	0	1	1	0	0	0	1	0	1	0	0	0	0	196	78	0	1	1	1	0	0	1	0	
	380-3-60	0	1	0	1	0	0	0	0	244	102	0	1	1	0	0	1	1	0	0	1	0	0	0	0	0	0	0	136	48	0	0	0	0	1	1	0	0	0	1	0	1	0	0	0	0	298	129	1	0	0	0	0	0	1	0
	460-3-60	0	1	0	1	0	0	0	0	202	81	1	0	0	0	1	0	1	0	0	1	0	0	0	0	0	0	0	114	37	1	0	1	0	0	1	0	0	0	1	0	1	0	0	0	0	246	103	1	1	1	0	0	1	0	
	380/415-3-50	0	1	0	1	0	0	0	0	252	106	0	1	0	1	0	1	1	0	0	1	0	0	0	0	0	0	0	142	51	1	1	0	0	1	1	0	0	0	1	0	0	1	0	0	0	0	310	15	1	1	1	1	0	0	0
30HXA 246	575-3-60	0	1	0	1	0	0	0	0	196	78	0	1	1	1	0	0	1	0	0	1	0	0	0	0	0	0	0	132	46	0	1	1	1	0	1	0	0	1	0	1	0	0	0	0	196	78	0	1	1	1	0	0	1	0	
	380-3-60	0	1	0	1	0	0	0	0	298	129	1	0	0	0	0	0	1	0	1	0	1	0	0	0	0	0	200	80	0	0	0	0	1	0	1	0	0	1	0	1	0	0	0	0	298	129	1	0	0	0	0	0	0	1	
	460-3-60	0	1	0	1	0	0	0	0	246	103	1	1	1	0	0	1	1	0	0	1	0	1	0	0	0	0	166	63	1	1	1	1	1	0	0	0	1	0	1	0	0	0	0	246	103	1	1	1	0	0	1	1	0		
	380/415-3-50	0	1	0	0	1	0	0	0	310	15	1	1	1	1	0	0	0	0	0	0	1	0	0	0	0	0	206	83	1	1	0	0	1	0	1	0	0	1	0	0	1	0	0	0	0	0	310	15	1	1	1	1	0	0	0
30HXA 261	575-3-60	0	1	0	1	0	0	0	0	196	78	0	1	1	1	0	0	1	0	0	1	0	1	0	0	0	0	160	60	0	0	1	1	1	1	0	0	0	1	0	1	0	0	0	0	196	78	0	1	1	1	0	0	1	0	
	380-3-60	0	1	0	1	0	0	0	0	298	129	1	0	0	0	0	0	1	0	0	1	0	1	0	0	0	0	244	102	0	1	1	0	0	1	1	0	0	1	0	0	1	0	0	0	0	298	129	1	0	0	0	0	0	0	1
	460-3-60	0	1	0	1	0	0	0	0	246	103	1	1	1	0	0	1	1	0	0	1	0	1	0	0	0	0	202	81	1	0	0	0	1	0	1	0	0	1	0	0	1	0	0	0	0	246	103	1	1	1	0	0	1	1	0
	380/415-3-50	0	1	0	0	1	0	0	0	310	15	1	1	1	1	0	0	0	0	0	1	0	1	0	0	0	0	252	106	0	1	0	1	0	1	1	0	0	1	0	0	1	0	0	0	0	310	15	1	1	1	1	0	0	0	0
30HXA 271	575-3-60	0	1	0	1	0	0	0	0	196	78	0	1	1	1	0	0	1	0	0	1	0	1	0	0	0	0	196	78	0	1	1	1	0	0	1	0	0	1	0	0	0	0	0	196	78	0	1	1	1	0	0	1	0		
	380-3-60	0	1	0	1	0	0	0	0	298	129	1	0	0	0	0	0	1	0	1	0	1	0	0	0	0	0	298	129	1	0	0	0	0	0	0	1	0	1	0	0	0	0	0	0	298	129	1	0	0	0	0	0	0	1	
	460-3-60	0	1	0	1	0	0	0	0	246	103	1	1	1	0	0	1	1	0	0	1	0	1	0	0	0	0	246	103	1	1	1	0	0	1	1	0	0	1	0	0	0	0	0	246	103	1	1	1	0	0	1	1	0		
	380/415-3-50	0	1	0	0	1	0	0	0	310	15	1	1	1	1	0	0	0	0	0	1	0	0	0	0	0	0	310	15	1	1	1	1	0	0	0	0	1	0	0	0	1	0	0	0	0	310	15	1	1	1	1	0	0	0	0
30HXC 206	575-3-60	0	1	0	0	0	0	0	0	106	33	1	0	0	0	0	1	0	0	0	1	0	0	0	0	0	0	60	10	0	1	0	1	0	0	0	0	0	0	1	0	0	0	0	0	0	128	44	0	0	1	1	0	1	0	0
	380-3-60	0	1	0	1	0	0	0	0	162	61	1	0	1	1	1	1	0	0	0	1	0	0	0	0	0	0	90	25	1	0	0	1	1	0	0	0	0	1	0	1	0	0	0	0	0	194	77	1	0	1	1	0	0	1	0
	460-3-60	0	1	0	0	0	0	0	0	134	47	1	1	1	1	0	1	0	0	0	1	0	0	0	0	0	0	74	17	1	0	0	0	1	0	0	0	0	1	0	1	0	0	0	0	160	60	0	0	1	1	1	1	0	0	
	380/415-3-50	0	1	0	1	0	0	0	0	164	62	0	1	1	1	1	0	0	0	0	1	0	0	0	0	0	0	92	26	0	1	0	1	1	0	0	0	0	1	0	1	0	0	0	0	0	200	80	0	0	0	0	1	0	1	0
30HXC 246	575-3-60	0	1	0	0	0	0	0	0	128	44	0	0	1	1	0	1	0	0	0	1	0	0	0	0	0	0	88	24	0	0	0	1	1	0	0	0	0	1	0	0	0	0	0	0	128	44	0	0	1	1	0	1	0	0	
	380-3-60	0	1	0	1	0	0	0	0	194	77	1	0	1	1	0	0	1	0	0	1	0	0	0	0	0	0	134	47	1	1	1	1	0	0	0	0	1	0	0	1	0	0	0	0	194	77	1	0	1	1	0	0	1	0	
	460-3-60	0	1	0	1	0	0	0	0	160	60	0	0	1	1	1	1	0	0	0	1	0	0	0	0	0	0	110	35	1	1	0	0	0	1	0	0	0	1	0	0	0	0	0	0	160	60	0	0	1	1	1	1	0	0	
	380/415-3-50	0	1	0	1	0	0	0	0	200	80	0	0	0	0	1	0	1	0	0	1	0	0	0	0	0	0	136	48	0	0	0	0	1	1	0	0	0	1	0	0	1	0	0	0	0	200	80	0	0	0	0	1	0	1	0
30HXC 261	575-3-60	0	1	0	0	0	0	0	0	128	44	0	0	1	1	0	1	0	0	0	1	0	0	0	0	0	106	33	1	0	0	0	0	1	0	0	0	0	1	0	0	0	0	0	0	128	44	0	0	1	1	0	1	0	0	
	380-3-60	0	1	0	1	0	0	0	0	194	77	1	0	1	1	0	0	1	0	0	1	0	1	0	0	0	162	61	1	0	1	1	1	0	0	0	0	1	0	1	0	0	0	0	0	194	77	1	0	1	1	0	0	1	0	
	460-3-60	0	1	0	1	0	0	0	0	160	60	0	0	1	1	1	1	0	0	0	1	0	0	0	0	0	134	47	1	1	1	1	0	1	0	0	0	1	0	1	0	0	0	0	160	60	0	0	1	1	1	1	0	0		
	380/415-3-50	0	1	0	1	0	0	0	0	200	80	0	0	0	0	1	0	1	0	0	1	0	1	0	0	0	0	164	62	0	1	1	1	1	0	0	0	0	1	0	0	1	0	0	0	0	200	80	0	0	0	0	1	0	1	0
30HXC 271	575-3-60	0	1	0	0	0	0	0	0	128	44	0	0	1	1	0	1	0	0	0	1	0	0	0	0	0	128	44	0	0	1	1	0	1	0	0	0	1	0	0	0	0	0	0	0	128	44	0	0	1	1	0	1	0	0	
	380-3-60	0	1	0	1	0	0	0	0	194	77	1	0	1	1	0	0	1	0	0	1	0	1	0	0	0	194	77	1	0	1	1	0	0	1	0	0	1	0	0	0	0	0	194	77	1	0	1	1	0	0	1	0			
	460-3-60	0	1	0	1	0	0	0	0	160	60	0	0	1	1	1	1	0	0	0	1	0	1	0	0	0	160	60	0	0	1	1	1	1	0	0	0	1	0	0	0	0	160	60	0	0	1	1	1	1	0	0				
	380/415-3-50	0	1	0	1	0	0	0	0	200	80	0	0	0	0	1	0	1	0	0	1	0	1	0	0	0	200	80	0	0	0	0	1	0	0	0	0	1	0	0	0	0	0	0	200	80	0	0	0	0	1	0	1	0		

* XL starter not available on 230-3-60, 208/230-3-60, or 230-3-50 units.

APPENDIX A — COMPRESSOR MUST TRIP AMP (MTA) SETTINGS (cont)

Setting for 30HXA,HXC206-271 with Wye-Delta Starter (1 = ON, 0 = OFF) (cont)

UNIT	V-PH-HZ	COMPRESSOR A1																COMPRESSOR A2																COMPRESSOR B1																					
		S1 Setting								MTA	S2 Value	S2 Setting								S1 Setting								MTA	S2 Value	S2 Setting								S1 Setting								MTA	S2 Value	S2 Setting							
		1	2	3	4	5	6	7	8			1	2	3	4	5	6	7	8	1	2	3	4	5	6	7	8			1	2	3	4	5	6	7	8	1	2	3	4	5	6	7	8			1	2	3	4	5	6	7	8
30HXA 206	575-3-60	1	1	0	1	0	0	0	0	160	60	0	0	1	1	1	1	0	0	1	1	0	0	0	0	0	0	1	1	0	1	0	0	0	0	196	78	0	1	1	1	0	0	1	0										
	380-3-60	1	1	0	1	0	0	0	0	244	102	0	1	1	0	0	1	1	0	0	1	1	0	0	0	0	0	1	1	0	0	0	0	0	298	129	1	0	0	0	0	0	0	1											
	230-3-60	1	1	0	0	1	0	0	0	402	38	0	1	1	0	0	1	0	0	1	1	0	1	0	0	0	0	1	1	0	1	0	0	0	490	60	0	0	1	1	1	1	0	0											
	208/230-3-60	1	1	0	0	1	0	0	0	446	49	1	0	0	0	1	1	0	0	0	1	1	0	1	0	0	0	0	1	1	0	0	1	0	0	542	73	1	0	0	1	0	1	0	1										
	460-3-60	1	1	0	1	0	0	0	0	202	81	1	0	0	0	1	0	1	0	0	1	1	0	0	0	0	0	1	1	0	0	0	0	0	246	103	1	1	1	0	0	1	1	0											
	230-3-50	1	1	0	0	1	0	0	0	414	41	1	0	0	1	0	1	0	0	0	1	1	0	1	0	0	0	0	1	1	0	0	1	0	0	518	67	1	1	0	0	0	0	1	0										
380/415-3-50	1	1	0	1	0	0	0	0	252	106	0	1	0	1	0	1	1	0	0	1	1	0	0	0	0	0	0	1	1	0	0	1	0	0	310	15	1	1	1	1	0	0	0	0											
30HXA 246	575-3-60	1	1	0	1	0	0	0	0	196	78	0	1	1	1	0	0	1	0	1	1	0	0	0	0	0	1	1	0	0	0	0	0	196	78	0	1	1	1	0	0	0	1												
	380-3-60	1	1	0	1	0	0	0	0	298	129	1	0	0	0	0	0	0	1	1	1	0	1	0	0	0	0	1	1	0	1	0	0	0	298	129	1	0	0	0	0	0	0	1											
	230-3-60	1	1	0	0	1	0	0	0	490	60	0	0	1	1	1	0	0	0	1	1	0	0	0	0	0	0	1	1	0	0	1	0	0	490	60	0	0	1	1	1	1	0	0											
	208/230-3-60	1	1	0	0	1	0	0	0	542	73	1	0	0	1	0	0	1	0	0	1	1	0	0	0	0	0	1	1	0	0	1	0	0	542	73	1	0	0	1	0	0	1	0											
	460-3-60	1	1	0	1	0	0	0	0	246	103	1	1	1	0	0	1	1	0	0	1	1	0	1	0	0	0	1	1	0	1	0	0	246	103	1	1	1	0	0	1	1	0												
	230-3-50	1	1	0	0	1	0	0	0	518	67	1	1	0	0	0	0	1	0	0	1	1	0	0	0	0	0	1	1	0	0	1	0	0	518	67	1	1	0	0	0	0	1	0											
380/415-3-50	1	1	0	1	0	0	0	0	310	15	1	1	1	1	0	0	0	0	0	1	1	0	1	0	0	0	0	1	1	0	0	1	0	0	310	15	1	1	1	1	0	0	0	0											
30HXA 261	575-3-60	1	1	0	1	0	0	0	0	196	78	0	1	1	1	0	0	1	0	1	1	0	0	0	0	0	1	1	0	1	0	0	0	196	78	0	1	1	1	0	0	0	1												
	380-3-60	1	1	0	1	0	0	0	0	298	129	1	0	0	0	0	0	0	1	1	1	0	1	0	0	0	0	1	1	0	1	0	0	0	298	129	1	0	0	0	0	0	0	1											
	230-3-60	1	1	0	0	1	0	0	0	490	60	0	0	1	1	1	0	0	0	1	1	0	0	0	0	0	0	1	1	0	0	1	0	0	490	60	0	0	1	1	1	1	0	0											
	208/230-3-60	1	1	0	0	1	0	0	0	542	73	1	0	0	1	0	0	1	0	0	1	1	0	0	0	0	0	1	1	0	0	1	0	0	542	73	1	0	0	1	0	0	1	0											
	460-3-60	1	1	0	1	0	0	0	0	246	103	1	1	1	0	0	1	1	0	0	1	1	0	1	0	0	0	1	1	0	1	0	0	246	103	1	1	1	0	0	1	1	0												
	230-3-50	1	1	0	0	1	0	0	0	518	67	1	1	0	0	0	0	1	0	0	1	1	0	0	0	0	0	1	1	0	0	1	0	0	518	67	1	1	0	0	0	0	1	0											
380/415-3-50	1	1	0	1	0	0	0	0	310	15	1	1	1	1	0	0	0	0	0	1	1	0	1	0	0	0	0	1	1	0	0	1	0	0	310	15	1	1	1	1	0	0	0	0											
30HXA 271	575-3-60	1	1	0	1	0	0	0	0	196	78	0	1	1	1	0	0	1	0	1	1	0	0	0	0	0	1	1	0	1	0	0	0	196	78	0	1	1	1	0	0	0	1												
	380-3-60	1	1	0	1	0	0	0	0	298	129	1	0	0	0	0	0	0	1	1	1	0	1	0	0	0	0	1	1	0	1	0	0	0	298	129	1	0	0	0	0	0	0	1											
	230-3-60	1	1	0	0	1	0	0	0	490	60	0	0	1	1	1	0	0	0	1	1	0	0	0	0	0	0	1	1	0	0	1	0	0	490	60	0	0	1	1	1	1	0	0											
	208/230-3-60	1	1	0	0	1	0	0	0	542	73	1	0	0	1	0	0	1	0	0	1	1	0	0	0	0	0	1	1	0	0	1	0	0	542	73	1	0	0	1	0	0	1	0											
	460-3-60	1	1	0	1	0	0	0	0	246	103	1	1	1	0	0	1	1	0	0	1	1	0	1	0	0	0	1	1	0	1	0	0	246	103	1	1	1	0	0	1	1	0												
	230-3-50	1	1	0	0	1	0	0	0	518	67	1	1	0	0	0	0	1	0	0	1	1	0	0	0	0	0	1	1	0	0	1	0	0	518	67	1	1	0	0	0	0	1	0											
380/415-3-50	1	1	0	1	0	0	0	0	310	15	1	1	1	1	0	0	0	0	0	1	1	0	1	0	0	0	0	1	1	0	0	1	0	0	310	15	1	1	1	1	0	0	0	0											
30HXC 206	575-3-60	1	1	0	1	0	0	0	0	106	33	1	0	0	0	0	0	1	0	0	1	1	0	0	0	0	0	1	1	0	0	0	0	106	33	1	0	0	0	0	0	0	0												
	380-3-60	1	1	0	1	0	0	0	0	162	61	1	0	1	1	1	0	0	0	1	1	0	0	0	0	0	0	1	1	0	0	0	0	162	61	1	0	0	1	1	0	0	0												
	230-3-60	1	1	0	1	0	0	0	0	266	113	1	0	0	0	1	1	1	0	0	1	1	0	0	0	0	0	1	1	0	0	0	0	266	113	1	0	0	0	1	1	0	0												
	208/230-3-60	1	1	0	1	0	0	0	0	296	128	0	0	0	0	0	0	0	0	1	1	0	0	0	0	0	0	1	1	0	0	0	0	296	128	0	0	0	0	0	0	0	0												
	460-3-60	1	1	0	0	0	0	0	0	134	47	1	1	1	1	0	1	0	0	0	1	1	0	0	0	0	0	1	1	0	0	0	0	134	47	1	0	0	0	1	0	0	0												
	230-3-50	1	1	0	1	0	0	0	0	272	116	0	0	1	0	0	1	1	1	0	0	1	1	0	0	0	0	1	1	0	0	0	0	272	116	0	0	1	0	0	1	1	0												
380/415-3-50	1	1	0	1	0	0	0	0	164	62	0	1	1	1	1	0	0	0	0	1	1	0	0	0	0	0	0	1	1	0	0	0	164	62	0	1	0	0	1	0	0	0													
30HXC 246	575-3-60	1	1	0	0	0	0	0	0	128	44	0	0	1	1	0	1	0	0	0	1	1	0	0	0	0	0	1	1	0	0	0	0	128	44	0	0	1	1	0	1	0	0												
	380-3-60	1	1	0	1	0	0	0	0	194	77	1	0	1	1	0	0	1	0	0	1	1	0	0	0	0	0	1	1	0	0	0	0	194	77	1	0	0	1	1	0	0	0												
	230-3-60	1	1	0	0	1	0	0	0	318	17	1	0	0	0	0	1	0	0	0	1	1	0	0	0	0	0	1	1	0	0	0	0	318	17	1	0	0	0	1	0	0	0												
	208/230-3-60	1	1	0	0	1	0	0	0	354	26	0	1	0	1	1	0	0	0	0	1	1	0	0	0	0	0	1	1	0	0	0	0	354	26	0	1	0	1	1	0	0	0												
	460-3-60	1	1	0	1	0	0	0	0	160	60	0	0	1	1	1	0	0	0	0	1	1	0	0	0	0	0	1	1	0	0	0	0	160	60	0	0	1	1	1	1	0	0												
	230-3-50	1	1	0	0	1	0	0	0	330	20	0	0	1	0	0	1	0	0	0	1	1	0	0	0	0	0	1	1	0	0	0	0	330	20	0	0	1	0	1	0	0	0												
380/415-3-5																																																							

APPENDIX B — CAPACITY LOADING SEQUENCE

Capacity Loading Sequence Example — The following tables show the loading sequence for a 30HX186 (50/50 split) and a 30HX161 (59/41 split) chiller. Each

compressor has 2 loaders. There is no difference in operation between “Staged” and “Equal” circuit loading on 2 compressor chillers.

STANDARD LOADING SEQUENCE (CIRCUIT A LEAD CIRCUIT, 2-COMPRESSOR UNIT)								
STAGE	COMP A1	LOADER A1	LOADER A2	COMP B1	LOADER B1	LOADER B2	% TOTAL CAPACITY (50/50 Split)	% TOTAL CAPACITY (59/41 Split)
0	0	0	0	0	0	0	0.0	0.0
1	1	0	0	0	0	0	20.0	23.5
2	1	1	0	0	0	0	35.0	41.1
3	1	1	1	0	0	0	50.0	58.8
4	1	1	0	1	1	0	70.0	70.0
5	1	1	0	1	1	1	85.0	82.4
6	1	1	1	1	1	1	100.0	100.0

CLOSE CONTROL LOADING SEQUENCE (CIRCUIT A LEAD CIRCUIT, 2-COMPRESSOR UNIT)								
STAGE	COMP A1	LOADER A1	LOADER A2	COMP B1	LOADER B1	LOADER B2	% TOTAL CAPACITY (50/50 Split)	% TOTAL CAPACITY (59/41 Split)
0	0	0	0	0	0	0	0.0	0.0
1	1	0	0	0	0	0	20.0	23.5
2	1	1	0	0	0	0	35.0	41.1
3	1	1	1	0	0	0	50.0	58.8
3A	1	0	0	1	0	0	40.0	40.0
3B	1	0	0	1	1	0	55.0	52.4
4	1	0	0	1	1	1	70.0	64.7
5	1	1	0	1	1	1	85.0	82.4
6	1	1	1	1	1	1	100.0	100.0

LEGEND

- 0 — Off
- 1 — On

NOTES:

1. Stage 3A (and 3B for 59/41 split) is not used by the algorithm when increasing stages. Stage 3 (and 2 for a 59/41 split) is not used when decreasing stages.
2. The % Total Capacities above are calculated based on compressor nominal tons. For the case of the 59/41 split above, the 30HX uses compressors with flow rates of 250 and 174 cfm (from compressor model numbers 06N_250 and 06N_174), which represent nominal tons of 80 and 56 (respectively) at 60 Hz. A factor of 40% is used when no loaders are energized, and a factor of 70% is used when Loader 1 is energized. The capacity shown for Stage 3B above is calculated as follows:

$$\begin{aligned} \text{\% Total Capacity} &= [(0.40 \times 80 + 0.70 \times 56) / (80 + 56)] \times 100\% \\ &= 52.4 \% \end{aligned}$$

Nominal Tons

COMPRESSOR PART NO.	60 Hz NOM. TONS	50 Hz NOM. TONS
06N_123	39	—
06N_146	46	39
06N_174	56	46
06N_209	66	56
06N_250	80	66
06N_300	—	80

APPENDIX B — CAPACITY LOADING SEQUENCE (cont)

The following tables show the loading sequence for 30HX206 (57/43 split) and 30HX271 (67/33 split) chillers. All compressors

have two loaders and the chillers are configured for *equal circuit loading*.

STANDARD LOADING SEQUENCE (CIRCUIT A LEAD CIRCUIT, 3-COMPRESSOR UNIT)

STAGE	COMP A1	LOADER A1	LOADER A2	COMP A2	COMP B1	LOADER B1	LOADER B2	% TOTAL CAPACITY (57/43 Split)	% TOTAL CAPACITY (67/33 Split)
0	0	0	0	0	0	0	0	0.0	0.0
1	1	0	0	0	0	0	0	14.3	13.3
2	1	1	0	0	0	0	0	25.0	23.3
3	1	1	1	0	0	0	0	35.7	33.3
4	1	1	0	0	1	1	0	55.2	46.7
5	1	1	0	0	1	1	1	68.2	56.7
6	1	1	1	0	1	1	1	78.9	66.7
7	1	1	0	1	1	1	1	83.0	80.0
8	1	1	1	1	1	1	1	100.0	100.0

CLOSE CONTROL LOADING SEQUENCE (CIRCUIT A LEAD CIRCUIT, 3-COMPRESSOR UNIT)

STAGE	COMP A1	LOADER A1	LOADER A2	COMP A2	COMP B1	LOADER B1	LOADER B2	% TOTAL CAPACITY (57/43 Split)	% TOTAL CAPACITY (67/33 Split)
0	0	0	0	0	0	0	0	0.0	0.0
1	1	0	0	0	0	0	0	14.3	13.3
2	1	1	0	0	0	0	0	25.0	23.3
3	1	1	1	0	0	0	0	35.7	33.3
3A	1	0	0	0	1	0	0	31.6	26.7
4	1	0	0	0	1	1	0	44.5	36.7
5	1	0	0	0	1	1	1	57.5	46.7
6	1	1	0	0	1	1	1	68.2	56.7
7	1	1	1	0	1	1	1	78.9	66.7
7A	1	0	0	1	1	1	1	65.9	60.0
8	1	1	0	1	1	1	1	83.0	80.0
9	1	1	1	1	1	1	1	100.0	100.0

LEGEND

- 0 — Off
- 1 — On

NOTE: Stages 3A and 7A are not used by the algorithm when increasing stages. Stages 3 and 7 are not used when decreasing stages.

APPENDIX B — CAPACITY LOADING SEQUENCE (cont)

The following tables show the loading sequence for 30HX206 (57/43 split) and 30HX271 (67/33 split) chillers. All compressors have two loaders and the chiller is configured for

staged circuit loading. Loaders A1 on compressors A1 and A2 are energized in parallel. The same is true for Loaders A2 on both compressors A1 and A2.

STANDARD LOADING SEQUENCE (CIRCUIT A LEAD CIRCUIT, 3-COMPRESSOR UNIT)									
STAGE	COMP A1	LOADER A1	LOADER A2	COMP A2	COMP B1	LOADER B1	LOADER B2	% TOTAL CAPACITY (57/43 Split)	% TOTAL CAPACITY (67/33 Split)
0	0	0	0	0	0	0	0	0.0	0.0
1	1	0	0	0	0	0	0	14.3	13.3
2	1	1	0	0	0	0	0	25.0	23.3
3	1	1	1	0	0	0	0	35.7	33.3
4	1	1	0	1	0	0	0	39.7	46.7
5	1	1	1	1	0	0	0	56.8	66.7
6	1	1	1	1	1	1	0	87.0	90.0
7	1	1	1	1	1	1	1	100.0	100.0

CLOSE CONTROL LOADING SEQUENCE (CIRCUIT A LEAD CIRCUIT, 3-COMPRESSOR UNIT)									
STAGE	COMP A1	LOADER A1	LOADER A2	COMP A2	COMP B1	LOADER B1	LOADER B2	% TOTAL CAPACITY (57/43 Split)	% TOTAL CAPACITY (67/33 Split)
0	0	0	0	0	0	0	0	0.0	0.0
1	1	0	0	0	0	0	0	14.3	13.3
2	1	1	0	0	0	0	0	25.0	23.3
3	1	1	1	0	0	0	0	35.7	33.3
3A	1	0	0	1	0	0	0	22.7	26.7
4	1	1	0	1	0	0	0	39.7	46.7
5	1	1	1	1	0	0	0	56.8	66.7
6	1	1	1	1	1	0	0	74.1	80.0
7	1	1	1	1	1	1	0	87.0	90.0
8	1	1	1	1	1	1	1	100.0	100.0

LEGEND

- 0 — Off
- 1 — On

NOTES:

1. Stage 3A is not used by the algorithm when increasing stages. Stage 3 is not used by the algorithm when decreasing stages.
2. The % Total Capacities above are calculated based on compressor nominal tons. For the case of the 57/43 split above, the 30HX uses compressors with flow rates of 209, 123, and 250 cfm (from compressor model numbers 06N_209, 06N_123, and 06N_250), which represent nominal tons of 66, 39, and 80 (respectively) at 60 Hz. A factor of 40% is used when no loaders are energized, and a factor of 70% is used when Loader 1 is energized. The capacity shown for Stage 4 above is calculated as follows:

$$\% \text{ Total Capacity} = [(0.70 \times 66 + 0.70 \times 39 + 0.0 \times 80) / (66 + 39 + 80)] \times 100\% = 39.7\%$$

APPENDIX C — AVAILABLE ACCESSORIES

ACCESSORY PART NUMBER	UNITS	DESCRIPTION OF ACCESSORY	COMMENTS
30GX-900---048	30HX (115 V Control)	Minimum Load Valve	Both circuits
30GX-900---049	30HX (230 V Control)	Minimum Load Valve	Both circuits
30HX-900---010	30HX All	Vibration Isolation Pads	
30GX-900---032	30HX206-271 (+1P)	Insulation Kit (18", 3-Pass Cooler with Economizer)	Tubesheets and heads
30GX-900---067	30HX161-186 (+1P)	Insulation Kit (16", 3-Pass Cooler with Economizer)	Tubesheets and heads
30HX-900---017	30HX076-096 (+1P)	Insulation Kit (14", 4-Pass Cooler, no Economizer)	Tubesheets and heads
30HX-900---018	30HX116-146 (-1P)	Insulation Kit (14", 1-Pass Cooler no Economizer)	Tubesheets and heads
30HX-900---021	30HX161-186 (-1P)	Insulation Kit (16", 1-Pass Cooler with Economizer)	Tubesheets and heads
30HX-900---023	30HX206-271 (-1P)	Insulation Kit (18", 1-Pass Cooler with Economizer)	Tubesheets and heads
30HX-900---024	30HX106 (+1P)	Insulation Kit (16", 4-Pass Cooler, no Economizer)	Tubesheets and heads
30HX-900---035	30HX076-096 (STD) 30HX116-146 (+1P)	Insulation Kit (14", 3-Pass Cooler, no Economizer)	Tubesheets and heads
30HX-900---036	30HX106 (STD)	Insulation Kit (16", 3-Pass Cooler, no Economizer)	Tubesheets and heads
30HX-900---037	30HX076-096 (-1P), 30HX116-146 (STD)	Insulation Kit (14", 2-Pass Cooler, no Economizer)	Tubesheets and heads
30HX-900---038	30HX161-186 (STD)	Insulation Kit (16", 2-Pass Cooler, with Economizer)	Tubesheets and heads
30HX-900---039	30HX206-271 (STD)	Insulation Kit (18", 2-Pass Cooler, with Economizer)	Tubesheets and heads
30HX-900---040	30HX106 (-1P)	Insulation Kit (16", 2-Pass Cooler, no Economizer)	Tubesheets and heads
30HX-900---001	30HX116-271	Sound Enclosure Panels	
30HX-900---011	30HX076-106	Sound Enclosure Panels	
30HX-900---004	30HX076-146	Victaulic Condenser Connections (18 in.)	
30HX-900---005	30HX161-186	Victaulic Condenser Connections (20 in.)	
30HX-900---015	30HX206-271	Victaulic Condenser Connections (22 in.)	
30HX-900---032	30HX All	Energy Management Module	
30HX-900---033	30HX (230 V, 460 V)	Control Transformer	
30HX-900---034	30HX (575 V)	Control Transformer	
CEPL130322-02	30HX All	Chillervisor System Manager III	
CPNLDLK-01	30HX All	DataLink Control Panel	
CPNLDPT-01	30HX All	DataPort Control Panel	
CRLIDASY001A00	30HX All	Remote Enhanced Display	
30GT-911---049	30HX All	GFI Convenience Outlet (60 Hz only)	

LEGEND

- (STD) — Chillers with standard number of cooler passes
- (-1P) — Chillers with minus one pass cooler option
- (+1P) — Chillers with plus one pass cooler option

APPENDIX D — COOLER AND CONDENSER PRESSURE DROP

The following charts list pressure drops for coolers and condensers.

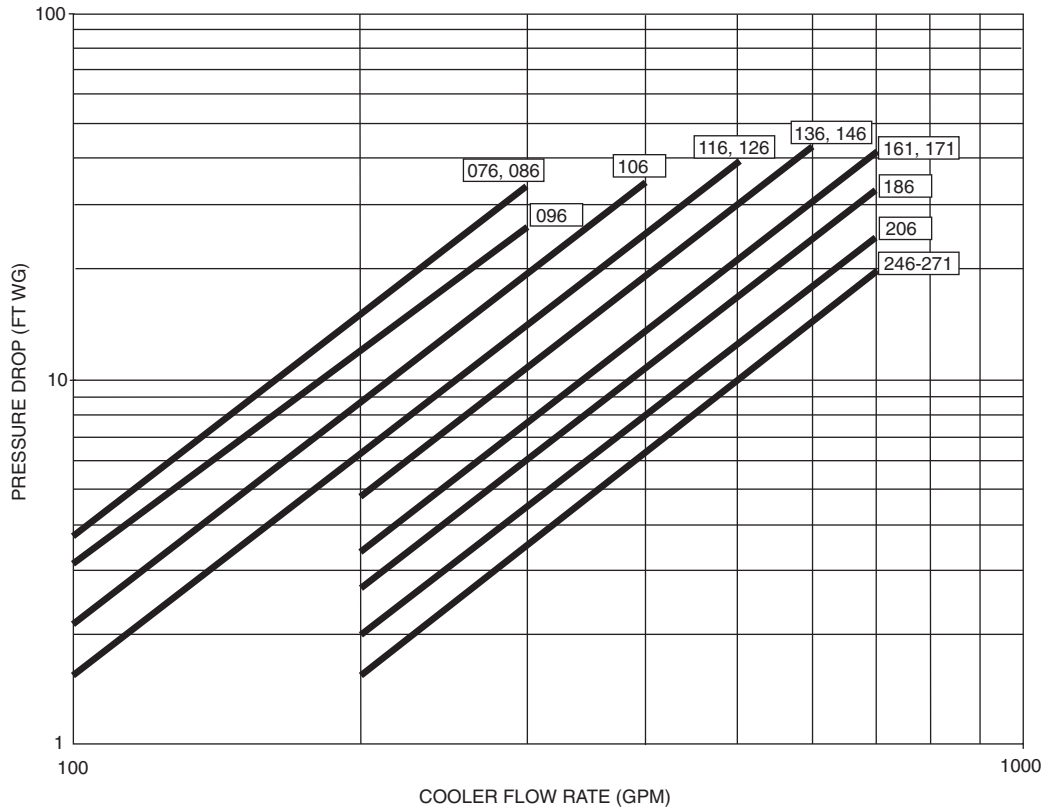

Unit Size Range

NOTE: Ft of water = 2.31 x psig.

30HX COOLER PRESSURE DROP — ENGLISH

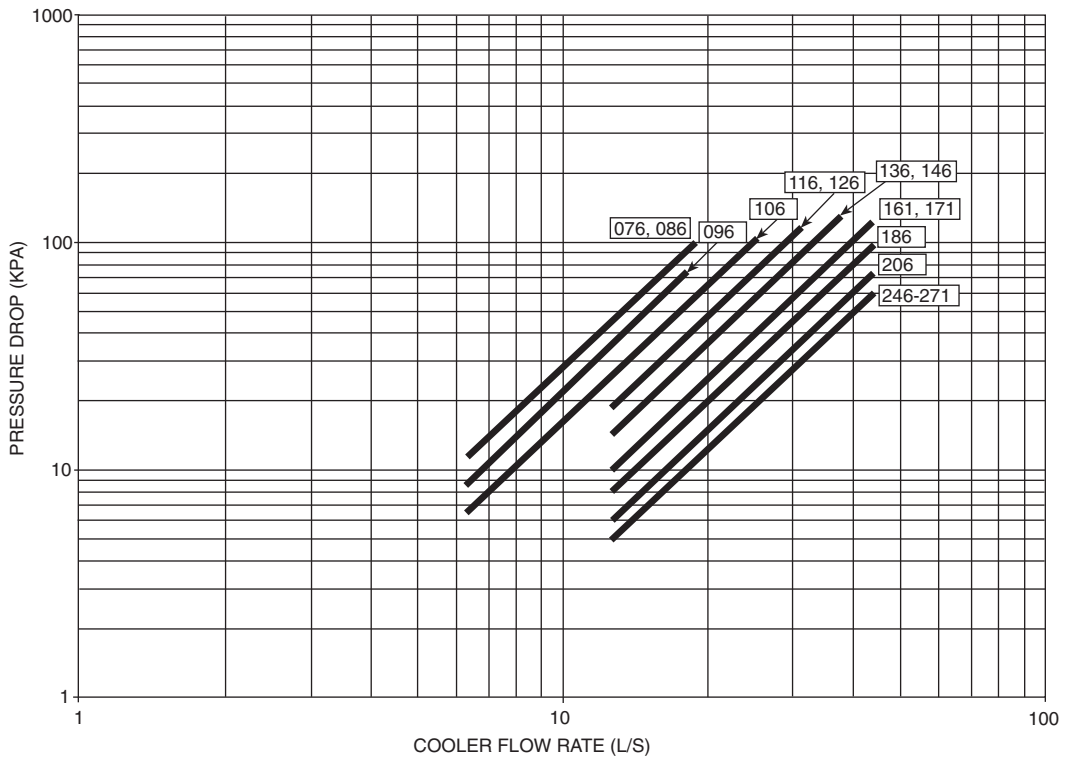

Unit Size Range

30HX COOLER PRESSURE DROP — SI

APPENDIX D — COOLER AND CONDENSER PRESSURE DROP (cont)

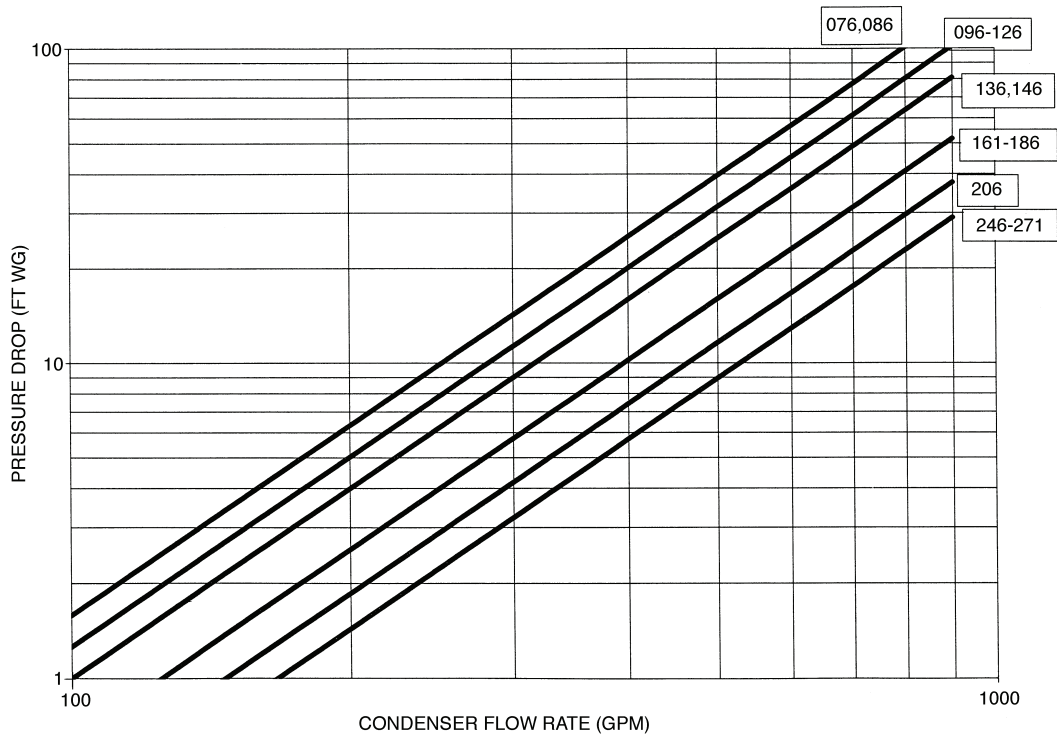

Unit Size Range

NOTE: Ft of water = 2.31 x psig.

30HX CONDENSER PRESSURE DROP — ENGLISH

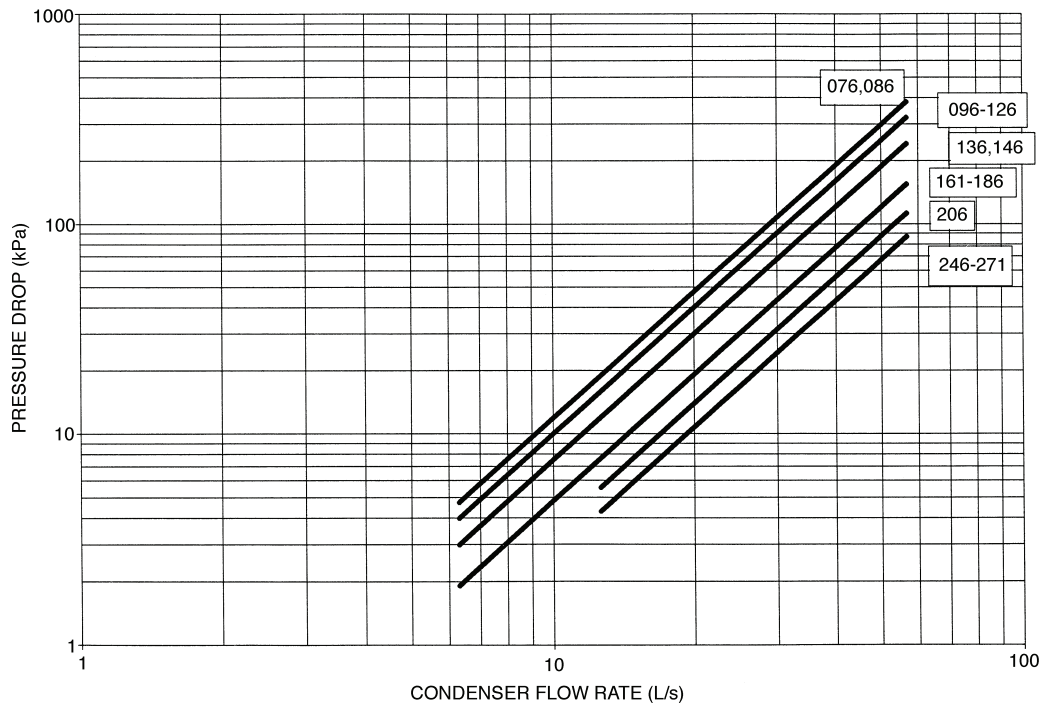

Unit Size Range

30HX CONDENSER PRESSURE DROP — SI

APPENDIX E — TYPICAL SYSTEM COMPONENTS

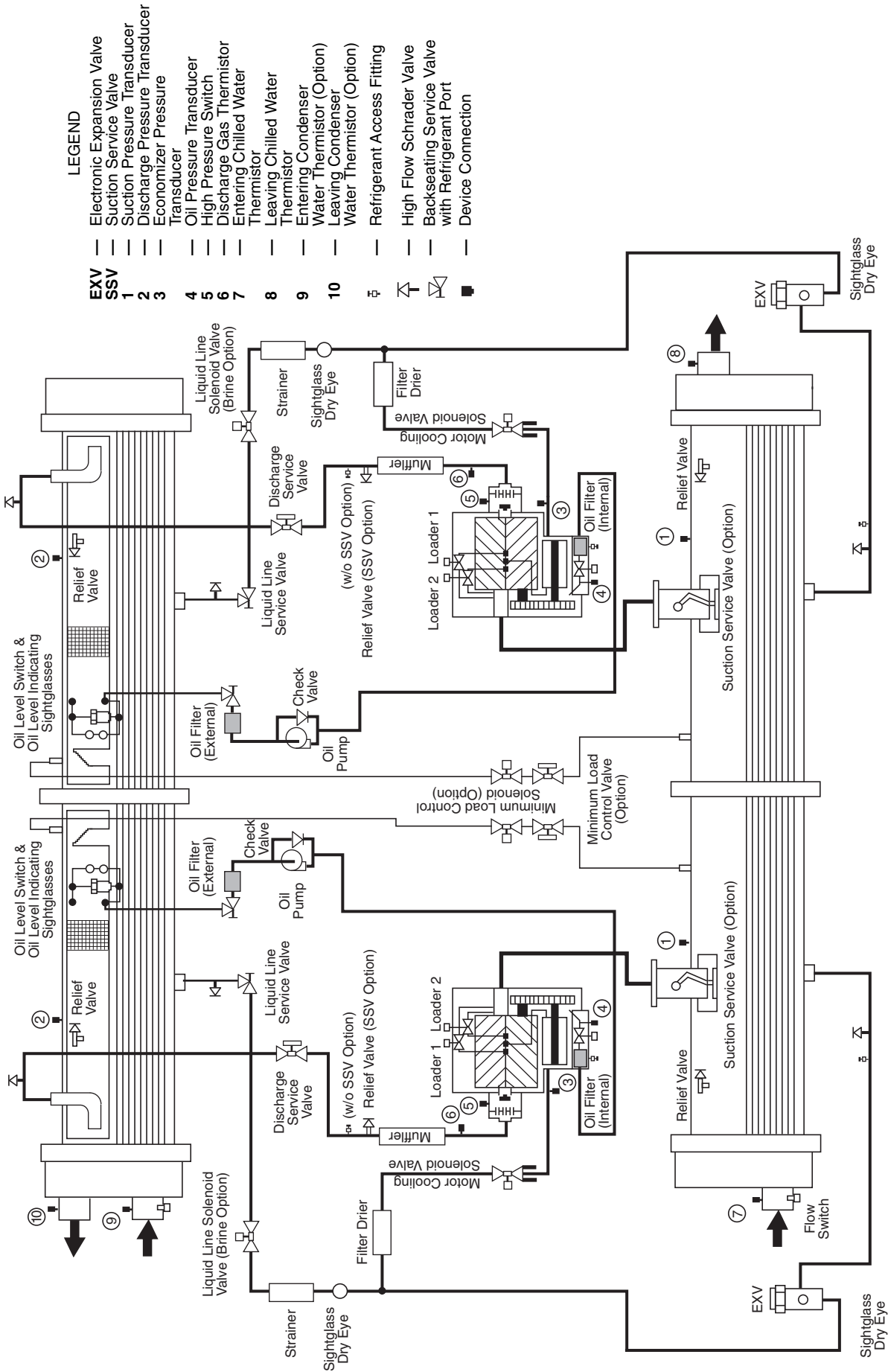

Typical System Components, 30HXC076-146, without Economizer

APPENDIX E — TYPICAL SYSTEM COMPONENTS (cont)

EXV	SSV	TXV	LEGEND
—	—	—	Electronic Expansion Valve
—	—	—	Suction Service Valve
—	—	—	Thermostatic Expansion Valve
1	—	—	Suction Pressure Transducer
2	—	—	Discharge Pressure Transducer
3	—	—	Economizer Pressure Transducer
4	—	—	Oil Pressure Transducer
5	—	—	High Pressure Switch
6	—	—	Discharge Gas Thermistor
7	—	—	Entering Chilled Water Thermistor
8	—	—	Leaving Chilled Water Thermistor
9	—	—	Entering Condenser Water Thermistor (Option)
10	—	—	Leaving Condenser Water Thermistor (Option)
—	—	—	Refrigerant Access Fitting
—	—	—	High Flow Schrader Valve
—	—	—	Backseating Service Valve with Refrigerant Port
—	—	—	Device Connection

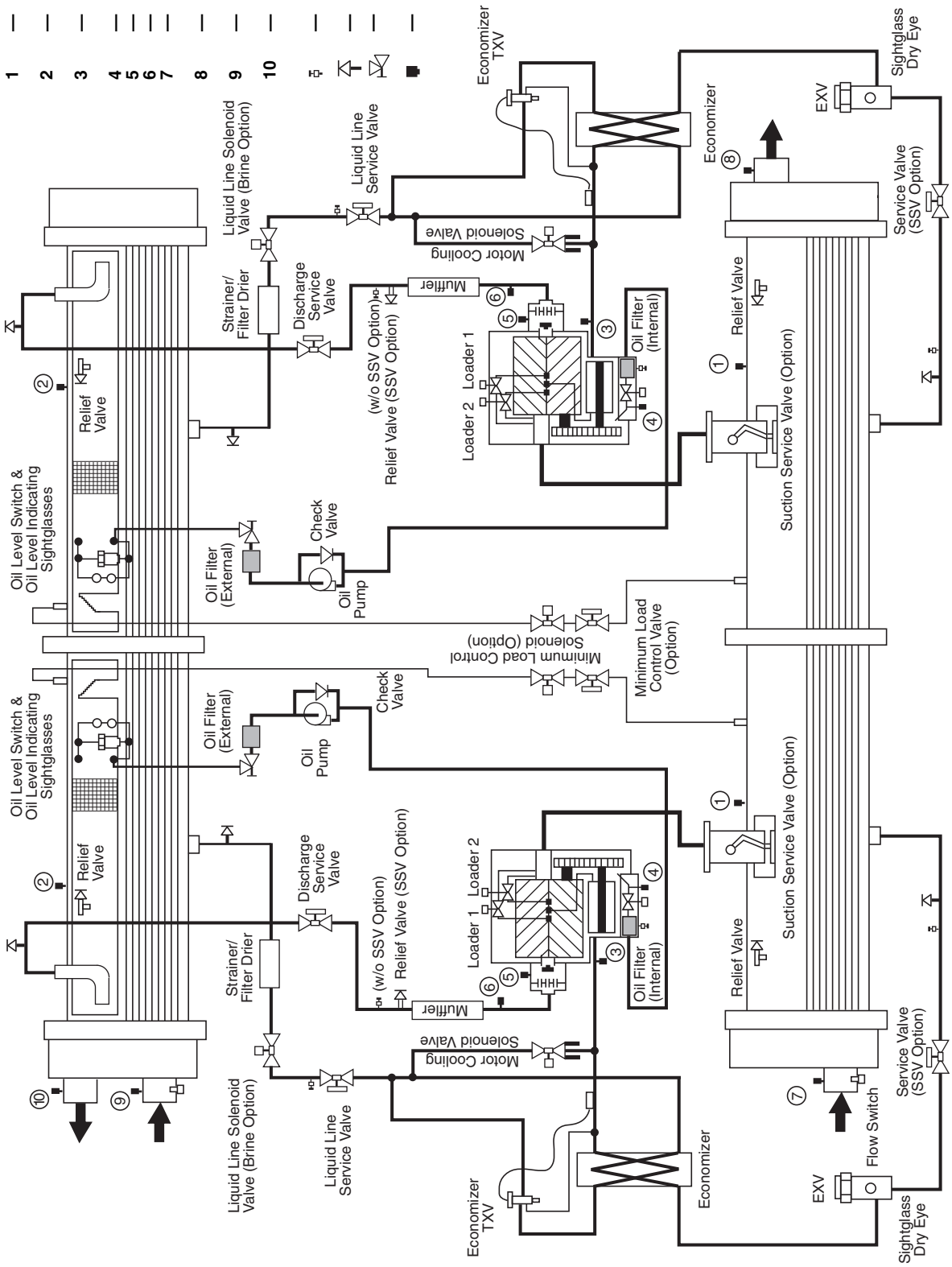

Typical System Components, 30HXC161-186, with Economizer

APPENDIX E — TYPICAL SYSTEM COMPONENTS (cont)

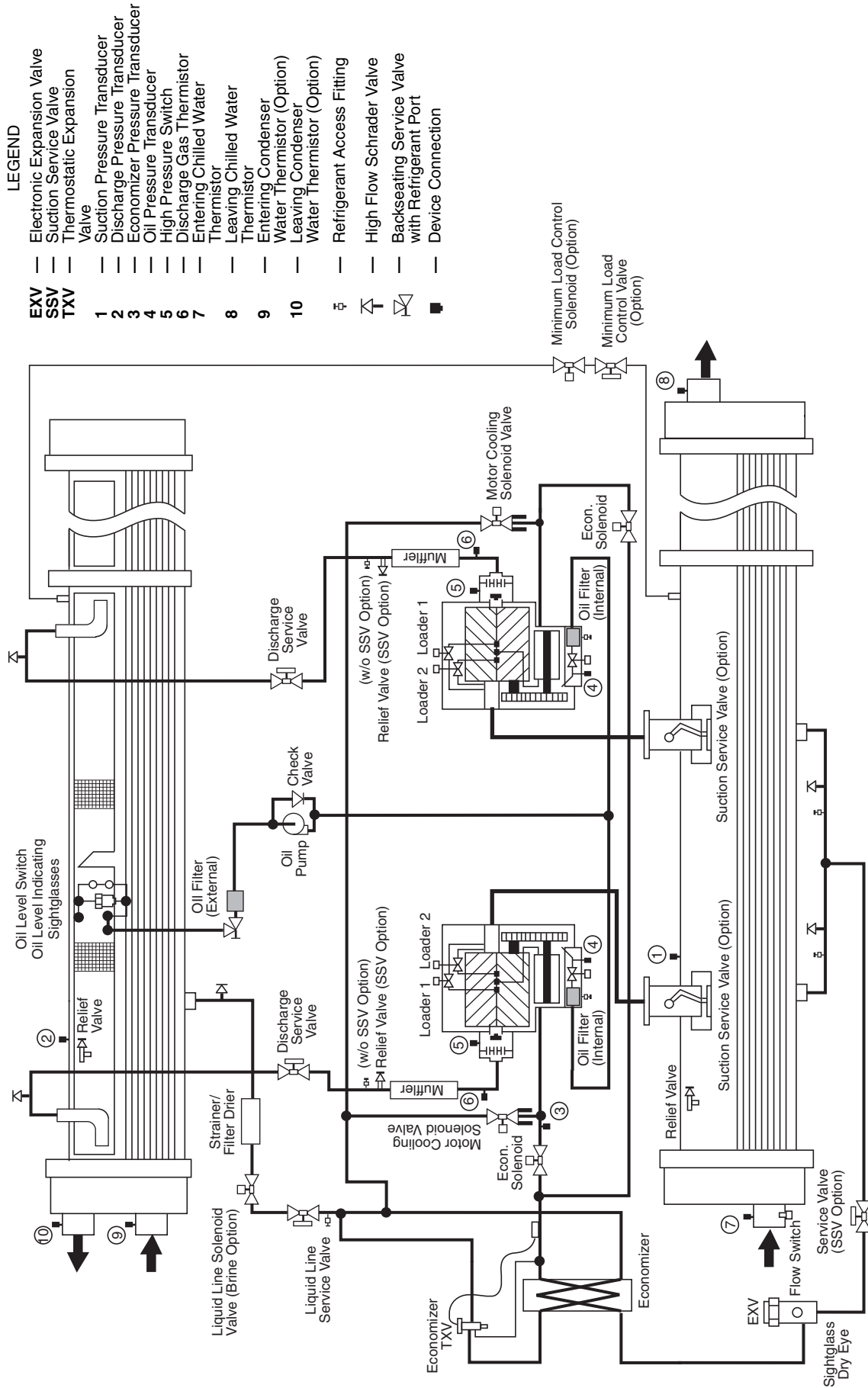

Typical System Components, 30HXC206-271 Circuit A, with Economizer

APPENDIX E — TYPICAL SYSTEM COMPONENTS (cont)

LEGEND

EXV	Electronic Expansion Valve
SSV	Suction Service Valve
TXV	Thermostatic Expansion Valve
1	Suction Pressure Transducer
2	Discharge Pressure Transducer
3	Economizer Pressure Transducer
4	Oil Pressure Transducer
5	High Pressure Switch
6	Discharge Gas Thermistor
7	Entering Chilled Water Thermistor
8	Leaving Chilled Water Thermistor
9	Entering Condenser Water Thermistor (Option)
10	Leaving Condenser Water Thermistor (Option)
⊕	Refrigerant Access Fitting
⊕	High Flow Schrader Valve
⊕	Backseating Service Valve with Refrigerant Port
■	Device Connection

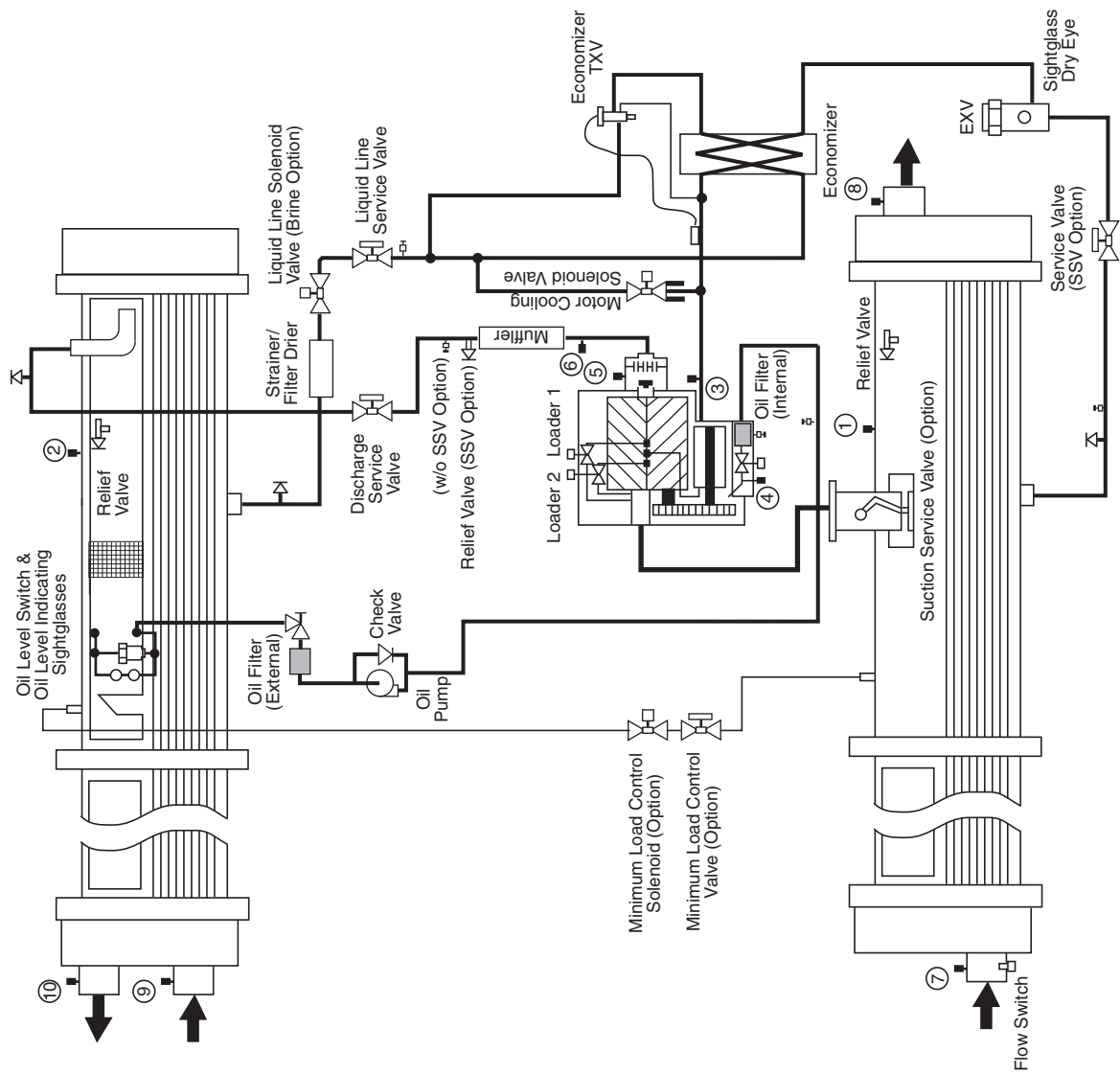

Typical System Components, 30HXC206-271 Circuit B, with Economizer

APPENDIX E — TYPICAL SYSTEM COMPONENTS (cont)

LEGEND

—	Electronic Expansion Valve
—	Suction Service Valve
—	Suction Pressure Transducer
—	Discharge Pressure Transducer
—	Economizer Pressure Transducer
—	Oil Pressure Transducer
—	High Pressure Switch
—	Discharge Gas Thermistor
—	Entering Water Thermistor
—	Leaving Water Thermistor
—	Refrigerant Access Fitting
—	High Flow Schrader Valve
—	Backseating Service Valve with Refrigerant Port
—	Device Connection

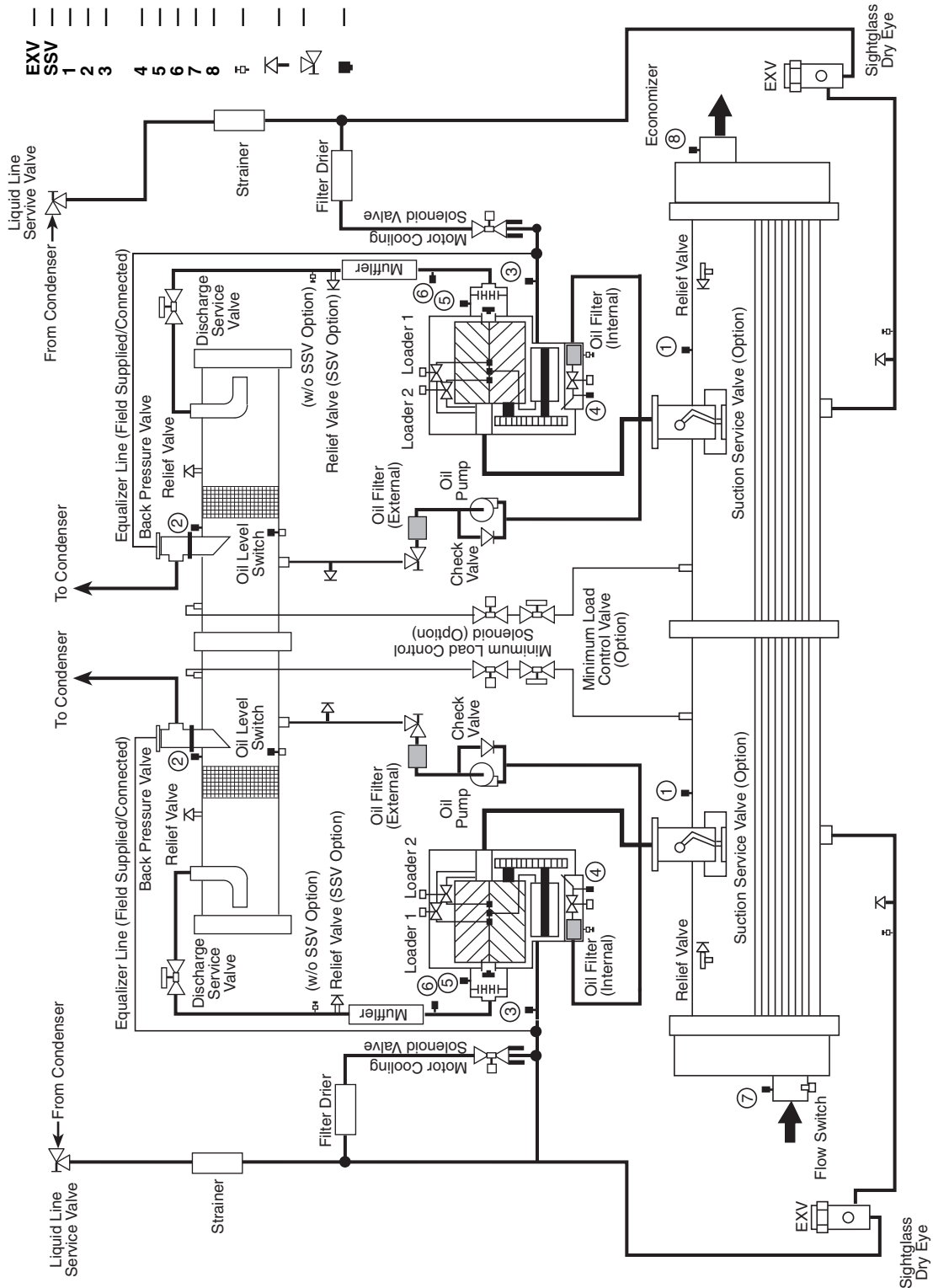

Typical System Components, 30HXA076-146, without Economizer

APPENDIX E — TYPICAL SYSTEM COMPONENTS (cont)

LEGEND

- EXV Electronic Expansion Valve
- SSV Suction Service Valve
- TXV Thermostatic Expansion Valve
- 1 Suction Pressure Transducer
- 2 Discharge Pressure Transducer
- 3 Economizer Pressure Transducer
- 4 Oil Pressure Transducer
- 5 High Pressure Switch
- 6 Discharge Gas Thermistor
- 7 Entering Water Thermistor
- 8 Leaving Water Thermistor
- ⊕ Refrigerant Access Fitting
- ↕ High Flow Schrader Valve
- ↔ Backseating Service Valve with Refrigerant Port
- Device Connection

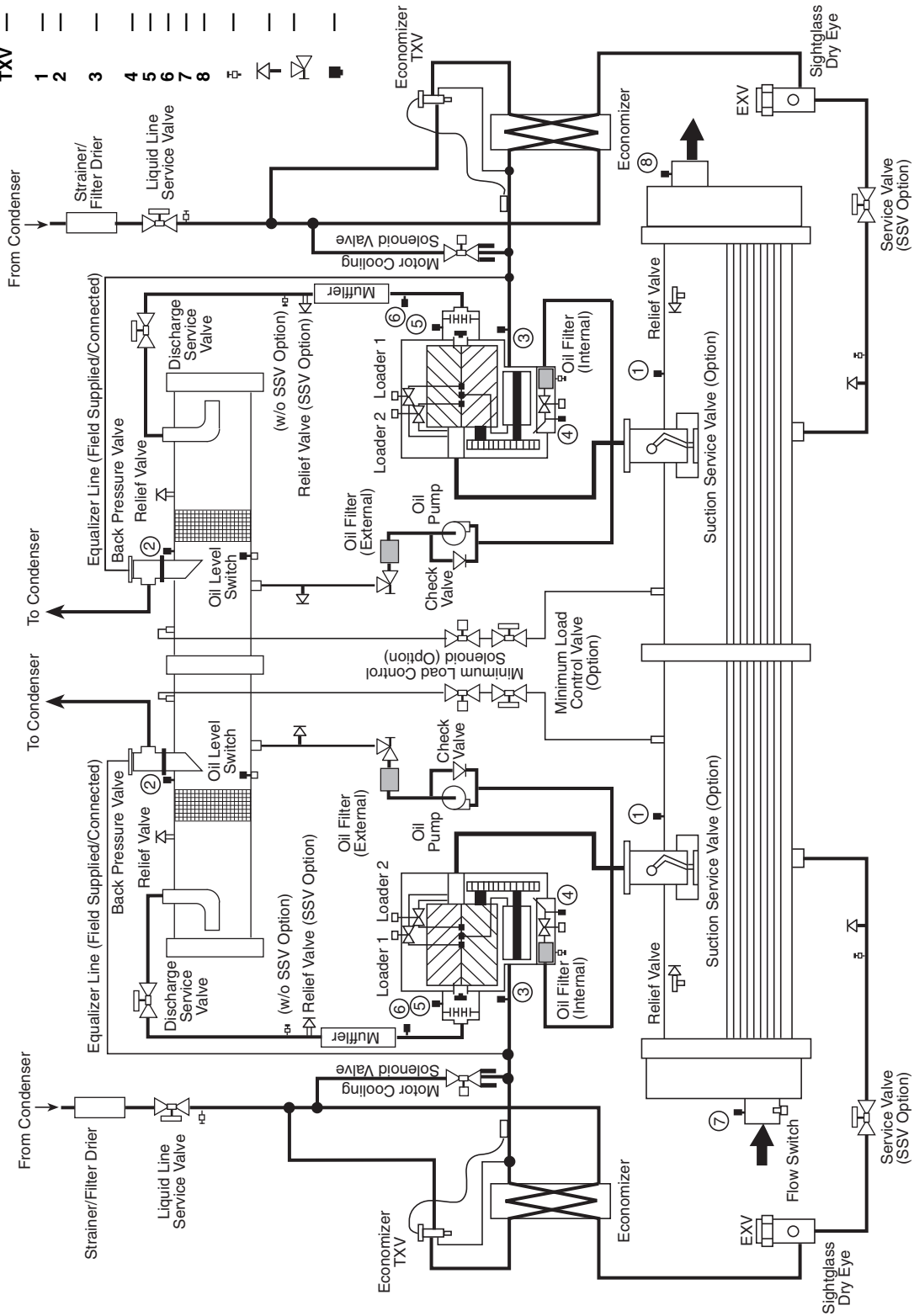

Typical System Components, 30HXA161-186, with Economizer

APPENDIX E — TYPICAL SYSTEM COMPONENTS (cont)

LEGEND	
EXV	Electronic Expansion Valve
SSV	Suction Service Valve
TXV	Thermostatic Expansion Valve
1	Suction Pressure Transducer
2	Discharge Pressure Transducer
3	Economizer Pressure Transducer
4	Oil Pressure Transducer
5	High Pressure Switch
6	Discharge Gas Thermistor
7	Entering Water Thermistor
8	Leaving Water Thermistor
⌀	Refrigerant Access Fitting
⌞	High Flow Schrader Valve
⌞	Backseating Service Valve with Refrigerant Port
■	Device Connection

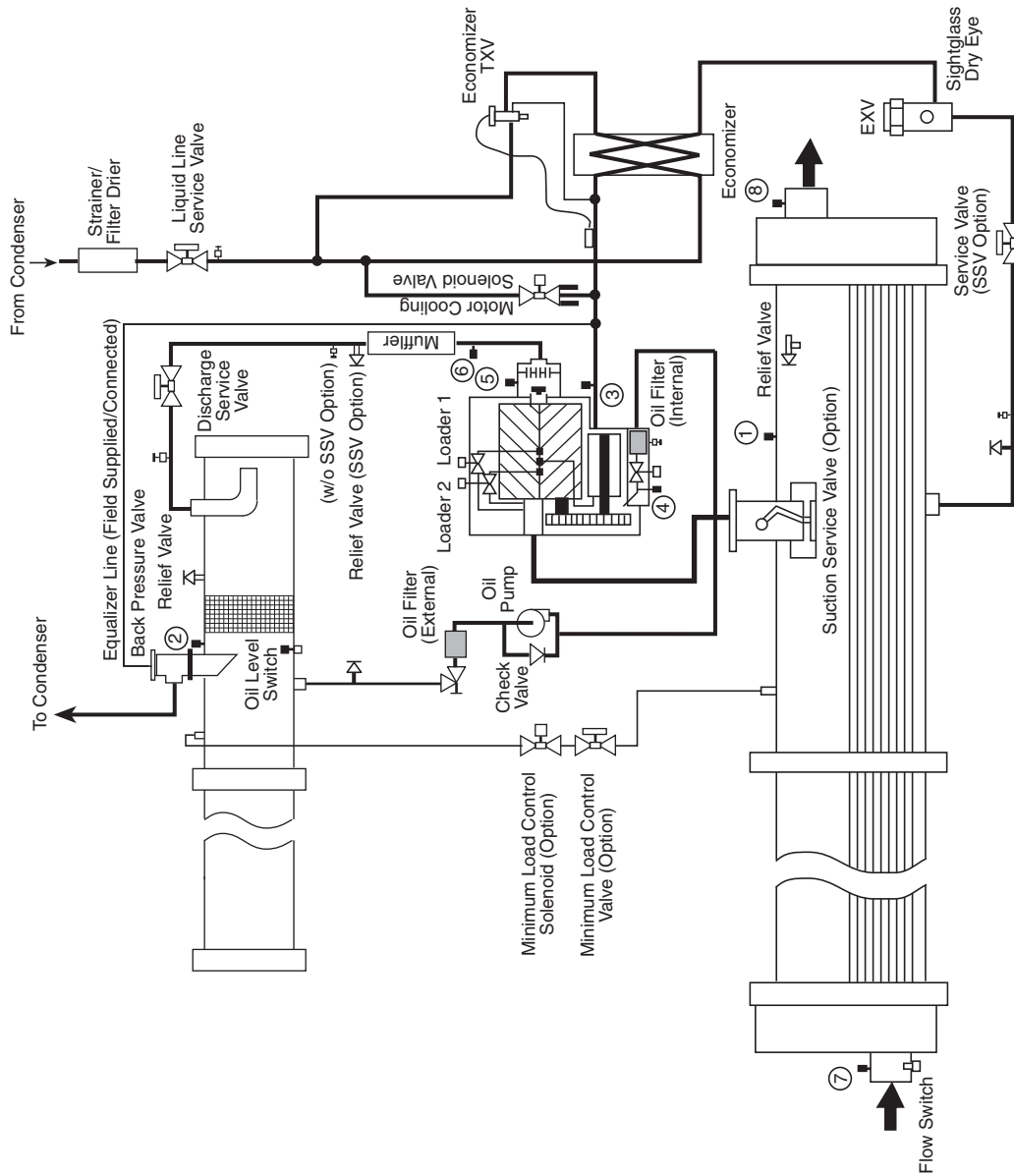

Typical System Components, 30HXA206-271 Circuit B, with Economizer

APPENDIX F — CCN CONFIGURATION

A_UNIT (Unit Operation): Status Display

DESCRIPTION	STATUS	UNITS	POINT	FORCIBLE
Control Mode	0 = Service Test 1 = Off - Local 2 = Off - CCN 3 = Off - Clock 4 = Off Emergency 5 = On - Local 6 = On - CCN 7 = On - Clock		STAT	N
Occupied	Yes/No		OCC	N
CCN Chiller	Start/Stop		CHIL_S_S	Y
Alarm State	0 = Normal 1 = Alarm 2 = Alert		ALM	N
Active Demand Limit	0 - 100	%	DEM_LIM	Y
Override Modes in Effect	Yes/No		MODE	N
Percent Total Capacity	0 - 100	%	CAP_T	N
Active Setpoint	snnn.n	°F	SP	N
Control Point	snn.n	°F	CTRL_PNT	Y
Entering Fluid Temp	snnn.n	°F	EWT	N
Leaving Fluid Temp	snnn.n	°F	LWT	N
Emergency Stop	Enable/Emstop*		EMSTOP	Y
Minutes Left for Start	00:00-15:00	min	MIN_LEFT	N
Heat Cool Select	Heat/Cool		HEATCOOL	N

* Enable = Run.

CIRCADIO (Circuit A Discrete Inputs/Outputs): Status Display

DESCRIPTION	STATUS	POINT	FORCIBLE
CIRC. A DISCRETE OUTPUTS			
Compressor A1 Relay	On/Off	K_A1_RLY	N
Compressor A2 Relay	On/Off	K_A2_RLY	N
Loader A1 Relay	On/Off	LOADR_A1	N
Loader A2 Relay	On/Off	LOADR_A2	N
Minimum Load Valve	On/Off	MLV	N
Oil Heater	On/Off	OILA_HTR	N
Motor Cooling A1 Solenoid	On/Off	MTRCL_A1	N
Motor Cooling A2 Solenoid	On/Off	MTRCL_A2	N
Oil Pump	On/Off	OILPMP_A	N
Oil Solenoid A1	On/Off	OILSL_A1	N
Oil Solenoid A2	On/Off	OILSL_A2	N
CIRC. A DISCRETE INPUTS			
Compressor A1 Feedback	On/Off	K_A1_FBK	N
Compressor A2 Feedback	On/Off	K_A2_FBK	N
Oil Level Switch	Close/Open	OILA_SW	N

CIRCA_AN (Circuit A Analog Parameters): Status Display

DESCRIPTION	STATUS	UNITS	POINT	FORCIBLE
CIRCUIT A ANALOG VALUES				
Percent Total Capacity	0 - 100	%	CAPA_T	N
Percent Available Cap	0 - 100	%	CAPA_A	N
Circuit Running Current	0 - 1200	AMPS	A_CURR	N
Discharge Pressure	nnn.n	PSIG	DP_A	N
Suction Pressure	nnn.n	PSIG	SP_A	N
Economizer Pressure	nnn.n	PSIG	ECNP_A	N
Discharge Superheat Temp	snnn.n	°F	SH_A	N
Discharge Gas Temp	nnn.n	°F	DISTMP_A	N
Discharge Gas Temp - A1	nnn.n	°F	DISTMPA1	N
Discharge Gas Temp - A2	nnn.n	°F	DISTMPA2	N
Saturated Condensing Tmp	snnn.n	°F	TMP_SCTA	N
Saturated Suction Temp	snnn.n	°F	TMP_SSTA	N
EXV % Open	0 - 100	%	EXV_A	N
Variable Head Press. PCT	0 - 100	%	VHPA	N
COMP A1 ANALOG VALUES				
A1 Oil Pressure Diff.	nnn.n	PSIG	DOP_A1	N
A1 Oil Pressure	nnn.n	PSIG	OP_A1	N
A1 Motor Temperature	nnn.n	°F	TMTR_A1	N
Comp A1 Running Current	0 - 600	AMPS	A1_CURR	N
Comp A1 % Must Trip Amps	0 - 100	%	A1_MTA	N
COMP A2 ANALOG VALUES				
A2 Oil Pressure Diff.	nnn.n	PSIG	DOP_A2	N
A2 Oil Pressure	nnn.n	PSIG	OP_A2	N
A2 Motor Temperature	nnn.n	°F	TMTR_A2	N
Comp A2 Running Current	0 - 600	AMPS	A2_CURR	N
Comp A2 % Must Trip Amps	0 - 100	%	A2_MTA	N

APPENDIX F — CCN CONFIGURATION (cont)
CIRCB DIO: (Circuit B Discrete Inputs/Outputs) Status Display

DESCRIPTION	STATUS	POINT	FORCIBLE
CIRC. B DISCRETE OUTPUTS			
Compressor B1 Solenoid	On/Off	K_B1_RLY	N
Compressor B2 Solenoid	On/Off	K_B2_RLY	N
Loader B1 Relay	On/Off	LOADR_B1	N
Loader B2 Relay	On/Off	LOADR_B2	N
Minimum Load Valve	On/Off	MLV	N
Oil Heater	On/Off	OILB_HTR	N
Motor Cooling B1 Solenoid	On/Off	MTRCL_B1	N
Motor Cooling B2 Solenoid	On/Off	MTRCL_B2	N
Oil Pump	On/Off	OILPMP_B	N
Oil Solenoid B1	On/Off	OILSL_B1	N
Oil Solenoid B2	On/Off	OILSL_B2	N
CIRC. B DISCRETE INPUTS			
Compressor B1 Feedback	On/Off	K_B1_FBK	N
Compressor B2 Feedback	On/Off	K_B2_FBK	N
Oil Level Switch	Close/Open	OILB_SW	N

CIRCB_AN: (Circuit B Analog Parameters) Status Display

DESCRIPTION	STATUS	UNITS	POINT	FORCIBLE
CIRCUIT B ANALOG VALUES				
Percent Total Capacity	0 - 100	%	CAPB_T	N
Percent Available Cap	0 - 100	%	CAPB_A	N
Circuit Running Current	0 - 1200	AMPS	B_CURR	N
Discharge Pressure	nnn.n	PSIG	DP_B	N
Suction Pressure	nnn.n	PSIG	SP_B	N
Economizer Pressure	nnn.n	PSIG	ECNP_B	N
Discharge Superheat Temp	snnn.n	°F	SH_B	N
Discharge Gas Temp	nnn.n	°F	DISTMP_B	N
Discharge Gas Temp - B1	nnn.n	°F	DISTMPB1	N
Discharge Gas Temp - B2	nnn.n	°F	DISTMPB2	N
Saturated Condensing Tmp	snnn.n	°F	TMP_SCTB	N
Saturated Suction Temp	snnn.n	°F	TMP_SSTB	N
EXV % Open	0 - 100	%	EXV_B	N
Variable Head Press. PCT	0 - 100	%	VHPB	N
COMP B1 ANALOG VALUES				
B1 Oil Pressure Diff.	nnn.n	PSIG	DOP_B1	N
B1 Oil Pressure	nnn.n	PSIG	OP_B1	N
B1 Motor Temperature	nnn.n	°F	TMTR_B1	N
Comp B1 Running Current	0 - 600	AMPS	B1_CURR	N
Comp B1 % Must Trip Amps	0 - 100	%	B1_MTA	N
COMP B2 ANALOG VALUES				
B2 Oil Pressure Diff.	nnn.n	PSIG	DOP_B2	N
B2 Oil Pressure	nnn.n	PSIG	OP_B2	N
B2 Motor Temperature	nnn.n	°F	TMTR_B2	N
Comp B2 Running Current	0 - 600	AMPS	B2_CURR	N
Comp B2 % Must Trip Amps	0 - 100	%	B2_MTA	N

APPENDIX F — CCN CONFIGURATION (cont)

OPTIONS: Status Display

DESCRIPTION	STATUS	UNITS	POINT	FORCIBLE
FANS				
Fan 1 Relay	On/Off		FAN_1	N
Fan 2 Relay	On/Off		FAN_2	N
Fan 3 Relay	On/Off		FAN_3	N
Fan 4 Relay	On/Off		FAN_4	N
UNIT ANALOG VALUES				
Cooler Entering Fluid	snnn.n	°F	COOL_EWT	N
Cooler Leaving Fluid	snnn.n	°F	COOL_LWT	N
Condenser Entering Fluid	snnn.n	°F	COND_EWT	N
Condenser Leaving Fluid	snnn.n	°F	COND_LWT	N
Lead/Lag Leaving Fluid	snnn.n	°F	DUAL_LWT	N
TEMPERATURE RESET				
4 - 20 ma Reset Signal	nn.n	ma	RST_MA	N
Outdoor Air Temperature	snnn.n	°F	OAT	Y
Space Temperature	snnn.n	°F	SPT	Y
DEMAND LIMIT				
4 - 20 ma Demand Signal	nn.n	ma	LMT_MA	N
Demand Limit Switch 1	On/Off		DMD_SW1	N
Demand Limit Switch 2	On/Off		DMD_SW2	N
CCN Loadshed Signal	0 = Normal 1 = Redline 2 = Loadshed		DL_STAT	N
PUMPS				
Cooler Pump Relay	On/Off		COOL_PMP	N
Condenser Pump Relay	On/Off		COND_PMP	N
MISCELLANEOUS				
Dual Setpoint Switch	On/Off		DUAL_IN	N
Cooler Flow Switch	On/Off		COOLFLOW	N
Condenser Flow Switch	On/Off		CONDFLOW	N
Ice Done	Yes/No		ICE	N
Cooler Heater	On/Off		COOL_HTR	N
4-20 ma Cooling Setpoint	nn.n	ma	CSP_IN	N
4-20 ma Heating Setpoint	nn.n	ma	HSP_IN	N
Liq. Line Solenoid Valve	Open/Close		LLSV	N
Dual Chiller Size	nnn	Tons	SIZE_DPX	N
Dual Chiller Pct Total Cap	0-100	%	CAPT_DPX	N
Dual Chiller Tons Avail	nnn	Tons	SIZEADPX	N
Dual Chiller Pct Avail Cap	0-100	%	CAPA_DPX	N

APPENDIX F — CCN CONFIGURATION (cont)
TCPM (Compressor Protection Module): Status Display

DESCRIPTION	STATUS	UNITS	POINT
TCPMA1			
TCPMA1 Status	NNNN		TCPMA1ST
TCPMA1 Status Indicators	NNNN		TCPMA1SI
Compr.A1 Must Trip Amps	NNN		CA1_MTA
A1 Must Trip Amps - Read	NNN	amps	CPMA1MTA
Compr.A1 TCPM Config Sw1	N		CA1_S1
A1 TCPM Config SW1 Read	N		CPMA1S1
A1 Motor Current	NNN.n	amps	A1CUR
A1 Phase 1 Motor Current	NNNN	amps	A1P1CUR
A1 Phase 2 Motor Current	NNNN	amps	A1P2CUR
A1 Phase 3 Motor Current	NNNN	amps	A1P3CUR
A1 Oil Pressure Voltage	NN.n	amps	A1OPV
A1 Econ Pressure Voltage	NN.n	amps	A1EPV
A1 Motor Temperature	NNN	amps	A1MTRTMP
TCPMA2			
TCPMA2 Status	NNNN		TCPMA2ST
TCPMA2 Status Indicators	NNNN		TCPMA2SI
Compr.A2 Must Trip Amps	NNN		CA2_MTA
A2 Must Trip Amps - Read	NNN	amps	CPMA2MTA
Compr.A2 TCPM Config Sw1	N		CA2_S1
A2 TCPM Config SW1 Read	N		CPMA2S1
A2 Motor Current	NNNN	amps	A2CUR
A2 Phase 1 Motor Current	NNNN	amps	A2P1CUR
A2 Phase 2 Motor Current	NNNN	amps	A2P2CUR
A2 Phase 3 Motor Current	NNNN	amps	A2P3CUR
A2 Oil Pressure Voltage	NN.n	amps	A2OPV
A2 Econ Pressure Voltage	NN.n	amps	A2EPV
A2 Motor Temperature	NNNN	amps	A2MTRTMP
TCPMB1			
TCPMB1 Status	NNNN		TCPMB1ST
TCPMB1 Status Indicators	NNNN		TCPMB1SI
Compr.B1 Must Trip Amps	NNN		CB1_MTA
B1 Must Trip Amps - Read	NNN	amps	CPMB1MTA
Compr.B1 TCPM Config Sw1	N		CB1_S1
B1 TCPM Config SW1 Read	N		CPMB1S1
B1 Motor Current	NNNN	amps	B1CUR
B1 Phase 1 Motor Current	NNNN	amps	B1P1CUR
B1 Phase 2 Motor Current	NNNN	amps	B1P2CUR
B1 Phase 3 Motor Current	NNNN	amps	B1P3CUR
B1 Oil Pressure Voltage	NN.n	amps	B1OPV
B1 Econ Pressure Voltage	NN.n	amps	B1EPV
B1 Motor Temperature	NNNN	amps	B1MTRTMP
TCPMB2			
TCPMB2 Status	NNNN		TCPMB2ST
TCPMB2 Status Indicators	NNNN		TCPMB2SI
Compr.B2 Must Trip Amps	NNN		CB2_MTA
B2 Must Trip Amps - Read	NNN	amps	CPMB2MTA
Compr.B2 TCPM Config Sw1	N		CB2_S1
B2 TCPM Config SW1 Read	N		CPMB2S1
B2 Motor Current	NNNN	amps	B2CUR
B2 Phase 1 Motor Current	NNNN	amps	B2P1CUR
B2 Phase 2 Motor Current	NNNN	amps	B2P2CUR
B2 Phase 3 Motor Current	NNNN	amps	B2P3CUR
B2 Oil Pressure Voltage	NN.n	amps	B2OPV
B2 Econ Pressure Voltage	NN.n	amps	B2EPV
B2 Motor Temperature	NNNN	amps	B2MTRTMP

APPENDIX F — CCN CONFIGURATION (cont)

7-DAY_OCC: Occupancy Configuration

DESCRIPTION	STATUS	POINT
Monday Occupied Time	00:00	MON_OCC
Monday Unoccupied Time	00:00	MON_UNC
Tuesday Occupied Time	00:00	TUE_OCC
Tuesday Unoccupied Time	00:00	TUE_UNC
Wednesday Occupied Time	00:00	WED_OCC
Wednesday Unoccupied Time	00:00	WED_UNC
Thursday Occupied Time	00:00	THU_OCC
Thursday Unoccupied Time	00:00	THU_UNC
Friday Occupied Time	00:00	FRI_OCC
Friday Unoccupied Time	00:00	FRI_UNC
Saturday Occupied Time	00:00	SAT_OCC
Saturday Unoccupied Time	00:00	SAT_UNC
Sunday Occupied Time	00:00	SUN_OCC
Sunday Unoccupied Time	00:00	SUN_UNC

ALARMDEF: Alarm Configuration

DESCRIPTION	STATUS	DEFAULT	UNITS	POINT
Alarm Routing Control	00000000	00000000		ALRM_CNT
Equipment Priority	0 to 7	4		EQP_TYPE
Comm Failure Retry Time	1 to 240	10	min	RETRY_TM
Re-alarm Time	1 to 255	30	min	RE-ALARM
Alarm System Name	XXXXXXXX	CHILLER		ALRM_NAM

BRODEFS: Broadcast Configuration

DESCRIPTION	STATUS	DEFAULT	UNITS	POINT
CCN Time/Date Broadcast	Yes/No	No		CCNBC
CCN OAT Broadcast	Yes/No	No		OATBC
Global Schedule Broadcast	Yes/No	No		GSBC
Broadcast Acknowledger	Yes/No	No		CCNBCACK
Daylight Savings Start:				
Month	1 to 12	4		STARTM
Week	1 to 5	1		STARTW
Day	1 to 7	7		STARTD
Minutes to Add	0 to 99	60	min	MINADD
Daylight Savings Stop				
Month	1 to 12	10		STOPM
Week	1 to 5	5		STOPW
Day	1 to 7	7		STOPD
Minutes to Subtract	0 to 99	60	min	MINSUB

DISPLAY: Navigator Configuration

DESCRIPTION	STATUS	DEFAULT	UNITS	POINT
Service Password	nnnn	1111		PASSWORD
Password Enable	Enable/Disable	Enable		PASS_EBL
Metric Display	Off/On	Off		DISPUNIT
Language Selection	0 = ENGLISH 1 = FRANCAIS 2 = ESPANOL 3 = PORTUGUES	0		LANGUAGE

APPENDIX F — CCN CONFIGURATION (cont)

EXV_CONF: Configuration

DESCRIPTION	STATUS	DEFAULT	UNITS	POINT
EXVA Stepper Type	0=1500 Step 1=12210 Step	1		EXVATYPE
EXVA Steps in Range	Type 0=1500 Type 1=15000	12210	STEPS	EXVARANG
EXVA Steps Per Second	Type 0=30 Type 1=300	300		EXVARATE
EXVA Fail Position in %		0	%	EXVAPOSF
EXVA Minimum Steps		0	STEPS	EXVAMINS
EXVA Maximum Steps	Type 0=1500 Type 1=12210	12210	STEPS	EXVAMAXS
EXVA Overrun Steps	Type 0=100 Type 1=1000	1000	STEPS	EXVAOVR
EXVB Stepper Type	0=1500 Step 1=15000 Step	1		EXVBTYPE
EXVB Steps in Range	Type 0=1500 Type 1=12210	12210	STEPS	EXVBRANG
EXVB Steps Per Second	Type 0=30 Type 1=300	300		EXVBRATE
EXVB Fail Position in %		0	%	EXVBPOSF
EXVB Minimum Steps		0	STEPS	EXVBMINS
EXVB Maximum Steps	Type 0=1500 Type 1=12210	12210	STEPS	EXVBMAXS
EXVB Overrun Steps	Type 0=100 Type 1=1000	1000	STEPS	EXVBOVR

OCCPC01S: Occupancy Configuration

DESCRIPTION	STATUS	UNITS	POINT
Timed Override Hours	0	hours	OVR-EXT
Period 1 DOW (MTWTFSSH)	00000000		DOW1
Occupied from	00:00		OCCTOD1
Occupied to	00:00		UNOCTOD1
Period 2 DOW (MTWTFSSH)	00000000		DOW2
Occupied from	00:00		OCCTOD2
Occupied to	00:00		UNOCTOD2
Period 3 DOW (MTWTFSSH)	00000000		DOW3
Occupied from	00:00		OCCTOD3
Occupied to	00:00		UNOCTOD3
Period 4 DOW (MTWTFSSH)	00000000		DOW4
Occupied from	00:00		OCCTOD4
Occupied to	00:00		UNOCTOD4
Period 5 DOW (MTWTFSSH)	00000000		DOW5
Occupied from	00:00		OCCTOD5
Occupied to	00:00		UNOCTOD5
Period 6 DOW (MTWTFSSH)	00000000		DOW6
Occupied from	00:00		OCCTOD6
Occupied to	00:00		UNOCTOD6
Period 7 DOW (MTWTFSSH)	00000000		DOW7
Occupied from	00:00		OCCTOD7
Occupied to	00:00		UNOCTOD7
Period 8 DOW (MTWTFSSH)	00000000		DOW8
Occupied from	00:00		OCCTOD8
Occupied to	00:00		UNOCTOD8

APPENDIX F — CCN CONFIGURATION (cont)

OPTIONS1: Options Configuration

DESCRIPTION	STATUS	DEFAULT	POINT
Cooler Fluid	1 = Water 2 = Med. Brine 3 = Low Brine	1	FLUIDTYP
Min. Load Valve Select	No/Yes	No	MLV_FLG
Head Press. Control Type	0 = None 1 = Air Cooled 2 = Water Cooled 3 = Common Condenser 4 = Independent Condenser	0	HEAD_TYP
Var Head Pressure Select	0 = None 1 = 4-20 mA 2 = 0-20 mA 3 = 20-0 mA	0	VHPTYPE
Pressure Transducers	No/Yes	Yes	PRESS_TY
Cooler Pump Control	Off/On	Off	CPC
Condenser Pump Interlock	Off/On	Off	CND_LOCK
Condenser Pump Control	0 = Not Controlled 1 = On when STATE is On 2 = On when compressors are On	0	CNPC
Condenser Fluid Sensors	No/Yes	No	CD_TEMP
Cnd HX Typ	0 = RTPF 1 = MCHX	0	COILTYPE
EMM Module Installed	No/Yes	No	EMM_BRD

OPTIONS2: Options Configuration

DESCRIPTION	STATUS	DEFAULT	UNITS	POINT
Control Method	0 = Switch 1 = 7 day sched. 2 = Occupancy 3 = CCN	0		CONTROL
Loading Sequence Select	1 = Equal loading 2 = Staged loading	1		SEQ_TYPE
Lead/Lag Sequence Select	1 = Automatic 2 = Circuit A leads 3 = Circuit B leads	1		LEAD_TYP
Compressor Sequence	1 = Automatic 2 = Compressor 1 Leads 3 = Compressor 2 Leads	1		COMP_SEQ
Cooling Setpoint Select	0 = Single 1 = Dual, remote switch controlled 2 = Dual, 7 day clock controlled 3 = Dual, CCN occupancy controlled 4 = 4-20 mA input	0		CLSP_TYP
Heating Setpoint Select	0 = Single 1 = Dual, remote switch controlled 2 = Dual, 7 day clock controlled 3 = Dual, CCN occupancy controlled 4 = 4-20 mA input	0		HTSP_TYP
Ramp Load Select	Enable/Disable	Enable		RAMP_EBL
Heat Cool Select	Cool	Cool		HEATCOOL
High LCW Alert Limit	2 to 60	60.0	ΔF	LCW_LMT
Minutes off time	0 to 15	0	min	DELAY
Deadband Multiplier	1.0 to 4.0	2.0		Z_GAIN
Close Control Select	Disable/Enable	Disable		CLS_CTRL
Ice Mode Enable	Disable/Enable	Disable		ICE_CNFG
Current Unbalance SetPnt	10 to 25	10	%	CUR_TRIP
Enable Noflow Detection	Disable/Enable	Enable		NOFLOWEN
Winterize Alert Config	Disable/Enable	Enable		WINTMSC
Alarm Relay Usage	0 = Alerts and Alarms 1 = Alarms Only 2 = Off	0		ALRMCNFG
Oil Filter Delta P Setpt	20 to 100	35	PSI	FP_SP

APPENDIX F — CCN CONFIGURATION (cont)

RESETCON: Options Configuration

DESCRIPTION	STATUS	DEFAULT	UNITS	POINT
COOLING RESET				
Cooling Reset Type	0 = No Reset 1 = 4 to 20 mA Input 2 = External Temp — OAT 3 = Return Fluid 4 = External Temp — SPT	0		CRST_TYP
4-20 MA RESET				
4-20 — Degrees Reset	-30 to +30	0	^F	C420_DEG
REMOTE RESET				
Remote — No Reset Temp	0 to 125	125	dF	CREM_NO
Remote — Full Reset Temp	0 to 125	0	dF	CREM_FUL
Remote — Degrees Reset	-30 to +30	0	^F	CREM_DEG
RETURN TEMPERATURE RESET				
Return — No Reset Temp	0 to 30	10	^F	CRTN_NO
Return — Full Reset Temp	0 to 10	0	^F	CRTN_FUL
Return — Degrees Reset	-30 to +30	0	^F	CRTN_DEG
HEATING RESET				
Heating Reset Type	0 = No Reset 1 = 4 to 20 mA Input 2 = External Temp — OAT 3 = Return Fluid 4 = External Temp — SPT	0		HRST_TYP
4-20 MA RESET				
4-20 — Degrees Reset	-30 to +30	0	^F	H420_DEG
REMOTE RESET				
Remote — No Reset Temp	0 to 125	50	dF	HREM_NO
Remote — Full Reset Temp	0 to 125	80	dF	HREM_FUL
Remote — Degrees Reset	-30 to +30	0	^F	HREM_DEG
RETURN TEMPERATURE RESET				
Return — No Reset Temp	0 to 10	10	^F	HRTN_NO
Return — Full Reset Temp	0 to 30	0	^F	HRTN_FUL
Return — Degrees Reset	-30 to +30	0	^F	HRTN_DEG
DEMAND LIMIT				
Demand Limit Select	0 = None 1 = External Switch Input 2 = 4 to 20 mA Input 3 = Loadshed	0		DMD_CTRL
Demand Limit at 20 mA	0 to 100	100	%	DMT20MA
Loadshed Group Number	0 to 99	0		SHED_NUM
Loadshed Demand Delta	0 to 60	0	%	SHED_DEL
Maximum Loadshed Time	0 to 120	60	min	SHED_TIM
Demand Limit Switch 1	0 to 100	80	%	DLSWSP1
Demand Limit Switch 2	0 to 100	50	%	DLSWSP2
LEAD/LAG				
Lead/Lag Chiller Enable	Disable/Enable	Disable		LL_ENA
Master/Slave Select	Slave/Master	Master		MS_SEL
Slave Address	0 to 239	2		SLV_ADDR
Lead/Lag Balance Select	0 = Master Leads 1 = Slave Leads 2 = Automatic	0		LL_BAL
Lead/Lag Balance Delta	40 to 400	168	hours	LL_BAL_D
Lag Start Delay	0 to 30	5	min	LL_DELAY
Parallel Configuration	Yes/No	No		PARALLEL

SCHEDOVR: Schedule and Timed Override Configuration

DESCRIPTION	STATUS	DEFAULT	UNITS	POINT
Schedule Number	0 - 99	0		SCHEDNUM
Override Time Limit	0 - 4	0	hours	OTL
Timed Override Hours	0 - 4	0	hours	OVR_EXT
Timed Override	Yes/No	No		TIMEOVER

APPENDIX F — CCN CONFIGURATION (cont)

SETPOINT: Configuration

DESCRIPTION	STATUS	DEFAULT	UNITS	POINT
COOLING				
Cool Setpoint 1	-20 to 70	44.0	°F	CSP1
Cool Setpoint 2	-20 to 70	44.0	°F	CSP2
Ice Setpoint	-20 to 32	32.0	°F	CSP3
HEATING				
Heat Setpoint 1	80 to 140	100.0	°F	HSP1
Heat Setpoint 2	80 to 140	100.0	°F	HSP2
RAMP LOADING				
Cooling Ramp Loading	0.2 to 2.0	1.0		CRAMP
Heating Ramp Loading	0.2 to 2.0	1.0		HRAMP
HEAD PRESSURE				
Head Pressure Setpoint A	80 to 140	113 (HXA) 85 (HXC)	°F	HSP_A
Head Pressure Setpoint B	80 to 140	113 (HXA) 85 (HXC)	°F	HSP_B
Approach Setpoint	0.1 to 20.0	3.0	°F	APRCH_SP

UNIT: Base Unit Configuration

DESCRIPTION	STATUS	DEFAULT	UNITS	POINT
Unit Type	1 = Air Cooled 2 = Water Cooled 3 = Split System 4 = Heat Machine 5 = Air Cooled Heat Reclaim	1		UNIT_TYP
Unit Size	76 to 350	76	TONS	SIZE
Circuit A % Capacity	0 to 100	50	%	CIRCACAP
Number Circ A Compressor	1 to 2	1		NUMCA
Number Circ B Compressor	0 to 2	1		NUMCB
Discharge Super. Setpoint	10 to 40	22.0	°F	DSH_SP
EXV Circ. A Min Position	0 to 100	8.0	%	EXVAMINP
EXV Circ. B Min Position	0 to 100	8.0	%	EXVBMINP
Fan Staging Select	0 to 8	0		FAN_TYPE
Compr. A1 Must Trip Amps	10 to 560	0*		CA1_MTA
Compr. A2 Must Trip Amps	10 to 560	0*		CA2_MTA
Compr. B1 Must Trip Amps	10 to 560	0*		CB1_MTA
Compr. B2 Must Trip Amps	10 to 560	0*		CB2_MTA
Economized?	No/Yes	Yes		ECON_SEL
Number of Evap. Passes	1 to 4	2		EVAPPASS
Circuit with LWT Sensor	A/B	A		LWTCKT

*See Appendix A.

SERVICE: Configuration

DESCRIPTION	STATUS	DEFAULT	UNITS	POINT
PID GAINS				
Head Pressure P Gain	-20.0 to +20.0	1.0		HD_PGAIN
Head Pressure I Gain	-20.0 to +20.0	0.1		HD_IGAIN
Head Pressure D Gain	-20.0 to +20.0	0.0		HD_DGAIN
Water Valve Minimum Pos.	0 to 100	20	%	HD_MIN
MISCELLANEOUS				
Motor Temp Setpoint	120.0 to 240.0	200.0	°F	MTR_T_SP
Brine Freeze Point	-20.0 to 34.0	34.0	°F	BRN_FRZ
Max. Cond. Temp Setpoint	100 to Default	*	°F	MCT_SP
EXVA Start Position	0 to 40	20	%	EXVSPOSA
EXVB Start Position	0 to 40	20	%	EXVSPOSB
COMPRESSOR ENABLE				
Enable Compressor A1	Enable/Dsable	Enable		ENABLEA1
Enable Compressor A2	Enable/Dsable	Enable		ENABLEA2
Enable Compressor B1	Enable/Dsable	Enable		ENABLEB1
Enable Compressor B2	Enable/Dsable	Enable		ENABLEB2

* HXA = 145 F, HXC = 118 F

APPENDIX F — CCN CONFIGURATION (cont)

ALARMS: Maintenance Display

DESCRIPTION	STATUS	POINT
Active Alarm #1	Axxx or Txxx	ALARM01C
Active Alarm #2	Axxx or Txxx	ALARM02C
Active Alarm #3	Axxx or Txxx	ALARM03C
Active Alarm #4	Axxx or Txxx	ALARM04C
Active Alarm #5	Axxx or Txxx	ALARM05C
Active Alarm #6	Axxx or Txxx	ALARM06C
Active Alarm #7	Axxx or Txxx	ALARM07C
Active Alarm #8	Axxx or Txxx	ALARM08C
Active Alarm #9	Axxx or Txxx	ALARM09C
Active Alarm #10	Axxx or Txxx	ALARM10C
Active Alarm #11	Axxx or Txxx	ALARM11C
Active Alarm #12	Axxx or Txxx	ALARM12C
Active Alarm #13	Axxx or Txxx	ALARM13C
Active Alarm #14	Axxx or Txxx	ALARM14C
Active Alarm #15	Axxx or Txxx	ALARM15C
Active Alarm #16	Axxx or Txxx	ALARM16C
Active Alarm #17	Axxx or Txxx	ALARM17C
Active Alarm #18	Axxx or Txxx	ALARM18C
Active Alarm #19	Axxx or Txxx	ALARM19C
Active Alarm #20	Axxx or Txxx	ALARM20C
Active Alarm #21	Axxx or Txxx	ALARM21C
Active Alarm #22	Axxx or Txxx	ALARM22C
Active Alarm #23	Axxx or Txxx	ALARM23C
Active Alarm #24	Axxx or Txxx	ALARM24C
Active Alarm #25	Axxx or Txxx	ALARM25C

CURRMODS: Maintenance Display

DESCRIPTION	STATUS	POINT
CSM controlling Chiller	ON/OFF	MODE_1
WSM controlling Chiller	ON/OFF	MODE_2
Master/Slave control	ON/OFF	MODE_3
Low Source Protection	ON/OFF	MODE_4
Ramp Load Limited	ON/OFF	MODE_5
Timed Override in effect	ON/OFF	MODE_6
Low Cooler Suction TempA	ON/OFF	MODE_7
Low Cooler Suction TempB	ON/OFF	MODE_8
Slow Change Override	ON/OFF	MODE_9
Minimum OFF time active	ON/OFF	MODE_10
Low Discharge Superheat A	ON/OFF	MODE_11
Low Discharge Superheat B	ON/OFF	MODE_12
Dual Setpoint	ON/OFF	MODE_13
Temperature Reset	ON/OFF	MODE_14
Demand Limit in effect	ON/OFF	MODE_15
Cooler Freeze Prevention	ON/OFF	MODE_16
Lo Tmp Cool/Hi Tmp Heat	ON/OFF	MODE_17
Hi Tmp Cool/Lo Tmp Heat	ON/OFF	MODE_18
Making ICE	ON/OFF	MODE_19
Storing ICE	ON/OFF	MODE_20
High SCT Circuit A	ON/OFF	MODE_21
High SCT Circuit B	ON/OFF	MODE_22
High Motor Current Cir. A	ON/OFF	MODE_23
High Motor Current Cir. B	ON/OFF	MODE_24
CKT A Off Ref Flow Delay	ON/OFF	MODE_25
CKT B Off Ref Flow Delay	ON/OFF	MODE_26
Circuit A — Pumping out	ON/OFF	MODE_27
Circuit B — Pumpout out	ON/OFF	MODE_28
Unit Off: No Water Flow	ON/OFF	MODE_29

APPENDIX F — CCN CONFIGURATION (cont)

DUALCHIL: Maintenance Display

DESCRIPTION	STATUS	UNITS	POINT
Dual Chiller Link Good?	Yes/No		DC_LINK
Master Chiller Role	STAND ALONE, Lead Chiller, Lag Chiller		MC_ROLE
Slave Chiller Role	STAND ALONE, Lead Chiller, Lag Chiller		SC_ROLE
Lead Chiller Ctrl Point	snnn.n	dF	LEAD_CP
Lag Chiller Ctrl Point	snnn.n	dF	LAG_CP
Control Point	snnn.n	dF	CTRL_PNT
Cool Entering Fluid-Slave	snnn.n	dF	COOLEWTS
Cool Leaving Fluid-Slave	snnn.n	dF	COOLLWTS
Cooler Entering Fluid	snnn.n	dF	COOL_EWT
Cooler Leaving Fluid	snnn.n	dF	COOL_LWT
Lead/Lag Leaving Fluid	snnn.n	dF	DUAL_LWT
Percent Avail.Capacity	0-100	%	CAP_A
Percent Avail.Cap.Slave	0-100	%	CAP_A_S
Lag Start Delay Time	hh:mm		LAGDELAY
Load/Unload Factor	snnn.n		SMZ
Load/Unload Factor-Slave	snnn.n		SMZSLAVE
Lead SMZ Clear Commanded	Yes/No		LEADSMZC
Lag- SMZ Clear Commanded	Yes/No		LAG_SMZC
Lag Commanded Off?	Yes/No		LAG_OFF
Dual Chill Lead CapLimit	0-100	%	DCLDCAPL
Dual Chill Lag CapLimit	0-100	%	DCLGCAPL
Dual Chiller Size	nnn	tons	SIZE_DPX
Dual Chiller Pct Total Cap	nnn	%	CAPT_DPX
Dual Chiller Tons Avail	nnn	tons	SIZEADPX
Dual Chiller Pct Avail Cap	nnn	%	CAPA_DPX

LOADFACT: Maintenance Display

DESCRIPTION	STATUS	UNITS	POINT
CAPACITY CONTROL			
Load/Unload Factor	snnn.n	%	SMZ
Control Point	snnn.n	°F	CTRL_PNT
Leaving Fluid Temp	snnn.n	°F	LWT
Calculated Z factor	n.n		Z_CALC
Capacity Trans. State	n		CAP_TRAN

MISCDATA: Maintenance Display

DESCRIPTION	STATUS	UNITS	POINT
MISCELLANEOUS			
Options Temp 1, EXV AN2	snnn.n	°F	OPT_TMP1
Options Temp 2, EXV AN1	snnn.n	°F	OPT_TMP2
Options Temp 3, SCB AN9	snnn.n	°F	OPT_TMP3
Options Temp 4, SCB AN10	snnn.n	°F	OPT_TMP4
Options Current 1	nn.n	ma	OPT_CUR1
Options Current 2	nn.n	ma	OPT_CUR2
Pumpout Failure Count, A	nnn	—	PFAIL_A
Pumpout Failure Count, B	nnn	—	PFAIL_B
HXC Brine Config Lock	No/Yes	—	BRN_LOCK

OCCDEFM: Occupancy Maintenance Display

DESCRIPTION	STATUS	POINT
Current Mode (1=Occup.)	0,1	MODE
Current Occup. Period #	0-8	PER-NO
Timed-Override in Effect	Yes/No	OVERLAST
Time-Override Duration	0-4 hours	OVR_HRS
Current Occupied Time	hh:mm	STRTTIME
Current Unoccupied Time	hh:mm	ENDTIME
Next Occupied Day		NXTOCDAY
Next Occupied Time	hh:mm	NXTOCTIM
Next Unoccupied Day		NXTUNDAY
Next Unoccupied Time	hh:mm	NXTUNTIM
Previous Unoccupied Day		PRVUNDAY
Previous Unoccupied Time	hh:mm	PRVUNTIM

APPENDIX F — CCN CONFIGURATION (cont)

OILPRESS: Maintenance Display

DESCRIPTION	STATUS	UNITS	POINT
A1 Oil Pressure	snnn.n	PSIG	OP_A1
A2 Oil Pressure	snnn.n	PSIG	OP_A2
B1 Oil Pressure	snnn.n	PSIG	OP_B1
B2 Oil Pressure	snnn.n	PSIG	OP_B2
A1 Oil Filter Diff. Press	nnn.n	PSI	FLTP_A1
A2 Oil Filter Diff. Press	nnn.n	PSI	FLTP_A2
B1 Oil Filter Diff. Press	nnn.n	PSI	FLTP_B1
B2 Oil Filter Diff. Press	nnn.n	PSI	FLTP_B2
OIL PRESSURE SETPOINTS			
Calculated Oil Press A1	nn.n	PSI	OIL_SPA1
Calculated Oil Press A2	nn.n	PSI	OIL_SPA2
Calculated Oil Press B1	nn.n	PSI	OIL_SPB1
Calculated Oil Press B2	nn.n	PSI	OIL_SPB2
MAX OPERATING PRESSURE			
Calculated MOP Circuit A	nn.n	°F	MOP_SPA
Calculated MOP Circuit B	nn.n	°F	MOP_SPB

STR TABS: Maintenance Display

DESCRIPTION	STATUS	UNITS	POINT
Machine Operating Hours	nnnnnn	hours	ABS_HRM
Machine Starts	nnnnnn		
Circuit A Run Hours	nnnnnn	hours	ABS_CYM
Compressor A1 Run Hours	nnnnnn	hours	ABS_HRA1
Compressor A2 Run Hours	nnnnnn	hours	ABS_HRA2
Circuit B Run Hours	nnnnnn	hours	ABS_HRB
Compressor B1 Run Hours	nnnnnn	hours	ABS_HRB1
Compressor B2 Run Hours	nnnnnn	hours	ABS_HRB2
Circuit A Starts	nnnnnn		ABS_CYA
Compressor A1 Starts	nnnnnn		ABS_CYA1
Compressor A2 Starts	nnnnnn		ABS_CYA2
Circuit B Starts	nnnnnn		ABS_CYB
Compressor B1 Starts	nnnnnn		ABS_CYB1
Compressor B2 Starts	nnnnnn		ABS_CYB2

STRTHOUR: Maintenance Display

DESCRIPTION	STATUS	UNITS	POINT
Machine Operating Hours	nnnnnn	hours	HR_MACH
Machine Starts	nnnnnn		CY_MACH
Circuit A Run Hours	nnnnnn	hours	HR_CIRA
Compressor A1 Run Hours	nnnnnn	hours	HR_A1
Compressor A2 Run Hours	nnnnnn	hours	HR_A2
Circuit B Run Hours	nnnnnn	hours	HR_CIRB
Compressor B1 Run Hours	nnnnnn	hours	HR_B1
Compressor B2 Run Hours	nnnnnn	hours	HR_B2
Circuit A Starts	nnnnnn		CY_CIRA
Compressor A1 Starts	nnnnnn		CY_A1
Compressor A2 Starts	nnnnnn		CY_A2
Circuit B Starts	nnnnnn		CY_CIRB
Compressor B1 Starts	nnnnnn		CY_B1
Compressor B2 Starts	nnnnnn		CY_B2

APPENDIX F — CCN CONFIGURATION (cont)

TESTMODE: Maintenance Display

DESCRIPTION	STATUS	UNITS	POINT
Service Test Mode	On/Off		MAN_CTRL
Manual Control Override	On/Off		FAC_CTRL
Compressor A1 Relay	On/Off		S_A1_RLY
Compressor A2 Relay	On/Off		S_A2_RLY
Compressor B1 Relay	On/Off		S_B1_RLY
Compressor B2 Relay	On/Off		S_B2_RLY
Loader A1 Relay	On/Off		S_LDR_A1
Loader A2 Relay	On/Off		S_LDR_A2
Loader B1 Relay	On/Off		S_LDR_B1
Loader B2 Relay	On/Off		S_LDR_B2
Oil Solenoid A1	On/Off		S_OSL_A1
Oil Solenoid A2	On/Off		S_OSL_A2
Oil Solenoid B1	On/Off		S_OSL_B1
Oil Solenoid B2	On/Off		S_OSL_B2
Motor Cooling A1 Solenoid	On/Off		S_MCS_A1
Motor Cooling A2 Solenoid	On/Off		S_MCS_A2
Motor Cooling B1 Solenoid	On/Off		S_MCS_B1
Motor Cooling B2 Solenoid	On/Off		S_MCS_B2
FAN 1 Relay	On/Off		S_FAN_1
FAN 2 Relay	On/Off		S_FAN_2
FAN 3 Relay	On/Off		S_FAN_3
FAN 4 Relay	On/Off		S_FAN_4
Oil Heater	On/Off		S_OHTR_A
Oil Heater	On/Off		S_OHTR_B
Oil Pump	On/Off		S_OPMP_A
Oil Pump	On/Off		S_OPMP_B
Cooler Pump Relay	On/Off		S_CL_PMP
Condenser Pump Relay	On/Off		S_CN_PMP
Minimum Load Valve	On/Off		S_MLV
Cooler Heater	On/Off		S_CHTR
Remote Alarm Relay	On/Off		S_ALRM
EXV % OPEN	0-100	%	S_EXV_A
EXV % OPEN	0-100	%	S_EXV_B
Var Head Press %	0-100	%	S_VHPA
Var Head Press %	0-100	%	S_VHPB
Liq. Line Solenoid Valve	Open/Close		S_LLSV

VERSIONS: Maintenance Display

DESCRIPTION	VERSION	STATUS
MBB	CESR131344-	nn-nn
EXV	CESR131172-	nn-nn
EMM	CESR131174-	nn-nn
SCB	CESR131226-	nn-nn
TI CCP 1	100233-1R3-	nn-nn
TI CCP 2	100233-1R3-	nn-nn
NAVIGATOR	CESR130227-	nn-nn

APPENDIX F — CCN CONFIGURATION (cont)

WINTLOG: Maintenance Display

DESCRIPTION	STATUS	POINT
Winterization Performed	No	WINTDONE
Date Winterized	00/00/00 00:00	WMSG00
Date Winterized	00/00/00 00:00	WMSG01
Date Winterized	00/00/00 00:00	WMSG02
Date Winterized	00/00/00 00:00	WMSG03
Date Winterized	00/00/00 00:00	WMSG04
Date Winterize Alerted	00/00/00 00:00	WALRT00
Date Winterize Alerted	00/00/00 00:00	WALRT01
Date Winterize Alerted	00/00/00 00:00	WALRT02
Date Winterize Alerted	00/00/00 00:00	WALRT03
Date Winterize Alerted	00/00/00 00:00	WALRT04
Date Winter Configured	00/00/00 00:00	WCONF00
Date Winter Unconfigured	00/00/00 00:00	WUCONF00
Date Winter Configured	00/00/00 00:00	WCONF01
Date Winter Unconfigured	00/00/00 00:00	WUCONF01
Date Winter Configured	00/00/00 00:00	WCONF02
Date Winter Unconfigured	00/00/00 00:00	WUCONF02

WSMDEFME: WSM Maintenance Display

DESCRIPTION	STATUS	POINT
WSM Active?	Yes/No	WSMSTAT
Chilled water temp	snn.n °F	CHWTEMP
Equipment status	On/Off	CHLRST
Commanded state	Enable/Disable/None	CHLRENA
CHW setpoint reset value	nn.n ^F	CHWRVAL
Current CHW setpoint	snn.n °F	CHWSTPT

APPENDIX G — MAINTENANCE SUMMARY AND LOG SHEETS
30HX Maintenance Interval Requirements

WEEKLY	
Compressor	Check Oil Level (30HXC).
Controls	Review Alarm/Alert History.
MONTHLY	
System	Check refrigerant charge levels.
QUARTERLY	
Cooler	Check refrigerant charge. Check all connections for leaks.
Controls	Perform an Automated Controls test. Run all Compressors and ensure proper operation.
Starter	Ensure operation of units flow switch.
ANNUALLY	
Compressor	Obtain and test an oil sample.
Cooler	Check all connections for leaks. Check approach on unit to determine if tubes need cleaning. Check for temperature drop across filter drier to determine if filter needs replacement.
Condenser	Check condenser approach to determine if tubes need to be cleaned (30HXC).
Starter	Inspect all electrical connections and tighten as needed. Measure current to each compressor and inspect contactors.
System	Verify proper operation of EXV's and TXV's

NOTE: Equipment failures caused by lack of adherence to the Maintenance Interval Requirements are not covered under warranty.

APPENDIX G — MAINTENANCE SUMMARY AND LOG SHEETS (cont)

30HX Maintenance Log

Month				1	2	3	4	5	6	7	8	9	10	11	12
Date				/ /	/ /	/ /	/ /	/ /	/ /	/ /	/ /	/ /	/ /	/ /	/ /
Operator															

UNIT SECTION	ACTION	UNIT	INTERVAL	ENTRY											
Compressor	Leak Test	ppm	Quarterly												
	Check Oil Level	yes/no	Quarterly												
	Change Oil Filter	yes/no	Year 1, then as necessary												
	Send Oil Sample Out for Analysis	yes/no	Annually												
Cooler	Check Flow Switch Operation	yes/no	Quarterly												
	Leak Test	yes/no	Quarterly												
	Inspect Relief Valves	yes/no	Quarterly												
	Record Water Pressure Differential	PSI	Quarterly												
	Inspect Water Pumps	yes/no	Quarterly												
	Clean Strainer	yes/no	Annually												
Condenser	Inspect and Clean Cooler Tubes	yes/no	Every 3 - 5 Years												
	Leak Test	ppm	Quarterly												
	Inspect Relief Valves	yes/no	Quarterly												
	Record Water Pressure Differential (30HXC)	PSI	Quarterly												
	Inspect Water Pumps and Cooling Tower (30HXC)	yes/no	Quarterly												
	Clean Strainer	yes/no	Annually												
Controls	Inspect and Clean Condenser Tubes (30HXC)	yes/no	Annually												
	General Cleaning and Tightening Connections	yes/no	Annually												
	Confirm Accuracy of Pressure Transducers	yes/no	Annually												
Starter	Confirm Accuracy of Thermistors	yes/no	Annually												
	General Tightening and Cleaning Connections	yes/no	Annually												
System	Inspect All Contactors	yes/no	Annually												
	Check Refrigerant Charge Level	yes/no	Quarterly												
	Verify Operation of EXVs and Record Position	0-100%	Annually												

NOTE: Equipment failures caused by lack of adherence to the Maintenance Interval Requirements are not covered under warranty.

APPENDIX G — MAINTENANCE SUMMARY AND LOG SHEETS (cont)

30HX Seasonal Shutdown Log

Month		1	2	3	4	5	6	7	8	9	10	11	12
Date		/ /	/ /	/ /	/ /	/ /	/ /	/ /	/ /	/ /	/ /	/ /	/ /
Operator													

UNIT SECTION	ACTION	ENTRY													
Cooler	Isolate and Drain Waterbox or Winterize														
Condenser (30HXC)	Isolate and Drain Waterbox														
Controls	Do Not Disconnect Control Power														

NOTE: Equipment failures caused by lack of adherence to the Maintenance Interval Requirements are not covered under warranty.

APPENDIX H — BACNET COMMUNICATION OPTION

The following section is used to configure the UPC Open controller which is used when the BACnet communication option is selected. The UPC Open controller is mounted in the main control box.

TO ADDRESS THE UPC OPEN CONTROLLER — The user must give the UPC Open controller an address that is unique on the BACnet* network. Perform the following procedure to assign an address:

1. If the UPC Open controller is powered, pull the screw terminal connector from the controller's power terminals labeled Gnd and HOT. The controller reads the address each time power is applied to it.
2. Using the rotary switches (see Fig. A and B), set the controller's address. Set the Tens (10's) switch to the tens digit of the address, and set the Ones (1's) switch to the ones digit.

As an example in Fig. B, if the controller's address is 25, point the arrow on the Tens (10's) switch to 2 and the arrow on the Ones (1's) switch to 5.

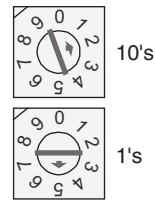

Fig. B — Address Rotary Switches

BACNET DEVICE INSTANCE ADDRESS — The UPC Open controller also has a BACnet Device Instance address. This Device Instance **MUST** be unique for the complete BACnet system in which the UPC Open controller is installed. The Device Instance is auto generated by default and is derived by adding the MAC address to the end of the Network Number. The Network Number of a new UPC Open controller is 16101, but it can be changed using i-Vu® Tools or BACView device. By default, a MAC address of 20 will result in a Device Instance of 16101 + 20 which would be a Device Instance of 1610120.

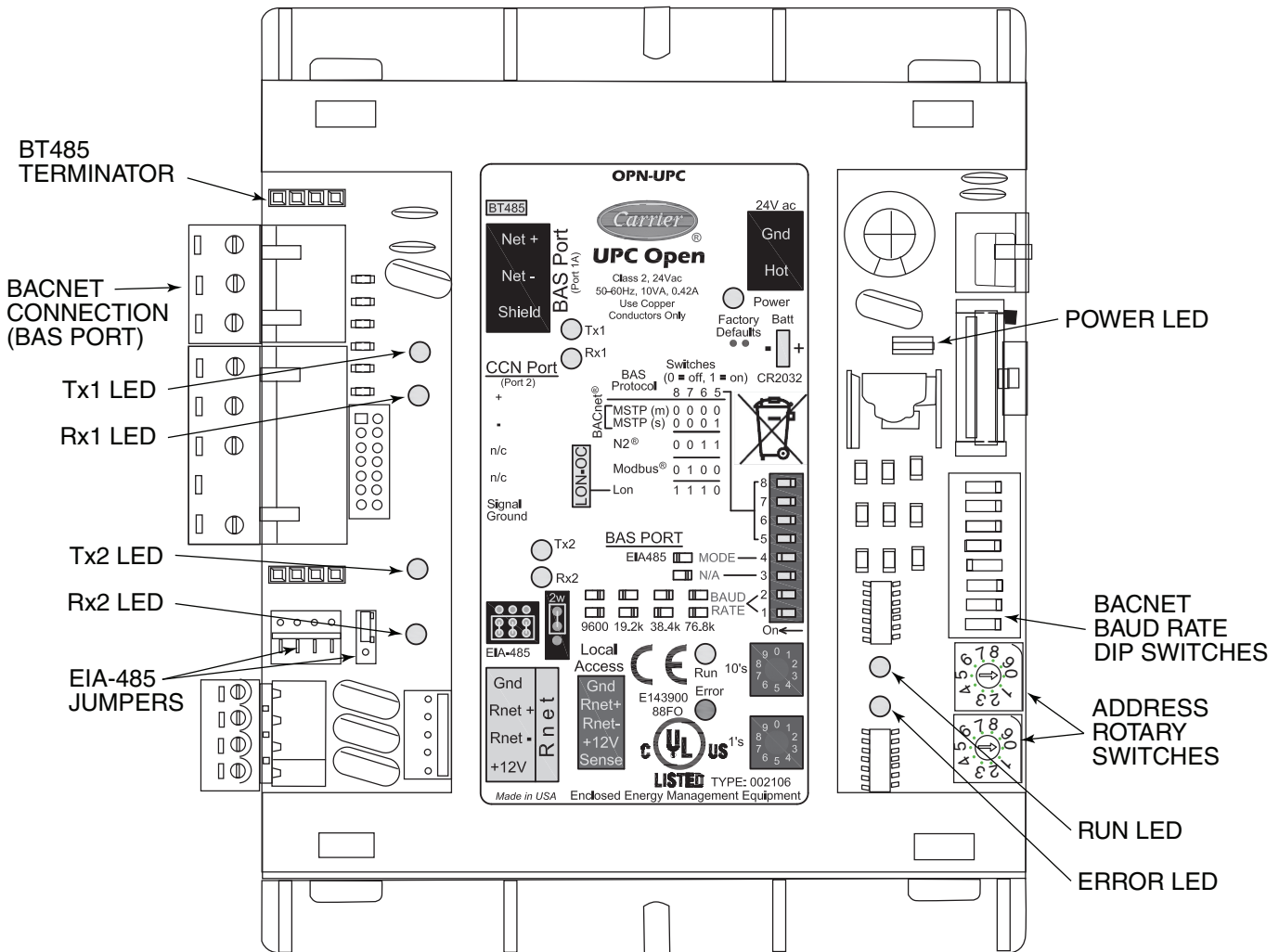

Fig. A — UPC Open Controller

* Sponsored by ASHRAE (American Society of Heating, Refrigerating, and Air Conditioning Engineers).

APPENDIX H — BACNET COMMUNICATION OPTION (cont)

CONFIGURING THE BAS PORT FOR BACNET MS/TP — Use the same baud rate and communication settings for all controllers on the network segment. The UPC Open controller is fixed at 8 data bits, No Parity, and 1 Stop bit for this protocol's communications.

If the UPC Open controller has been wired for power, pull the screw terminal connector from the controller's power terminals labeled Gnd and HOT. The controller reads the DIP Switches and jumpers each time power is applied to it.

Set the BAS Port DIP switch DS3 to “enable.” Set the BAS Port DIP switch DS4 to “E1-485.” Set the BMS Protocol DIP switches DS8 through DS5 to “MSTP.” See Table A.

Table A — SW3 Protocol Switch Settings for MS/TP

DS8	DS7	DS6	DS5	DS4	DS3
Off	Off	Off	Off	On	Off

Verify that the EIA-485 jumpers below the CCN Port are set to EIA-485 and 2W.

The example in Fig. C shows the BAS Port DIP Switches set for 76.8k (Carrier default) and MS/TP.

Set the BAS Port DIP Switches DS2 and DS1 for the appropriate communications speed of the MS/TP network (9600, 19.2k, 38.4k, or 76.8k bps). See Fig. C and Table B.

Table B — Baud Selection Table

BAUD RATE	DS2	DS1
9,600	Off	Off
19,200	On	Off
38,400	Off	On
76,800	On	On

WIRING THE UPC OPEN CONTROLLER TO THE MS/TP NETWORK — The UPC Open controller communicates using BACnet on an MS/TP network segment communications at 9600 bps, 19.2 kbps, 38.4 kbps, or 76.8 kbps.

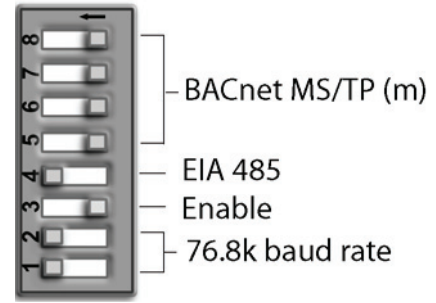

Fig. C — DIP Switches

Wire the controllers on an MS/TP network segment in a daisy-chain configuration. Wire specifications for the cable are 22 AWG (American Wire Gage) or 24 AWG, low-capacitance, twisted, stranded, shielded copper wire. The maximum length is 2000 ft.

Install a BT485 terminator on the first and last controller on a network segment to add bias and prevent signal distortions due to echoing. See Fig. A, D, and E.

To wire the UPC Open controller to the BAS network:

1. Pull the screw terminal connector from the controller's BAS Port.
2. Check the communications wiring for shorts and grounds.
3. Connect the communications wiring to the BAS port's screw terminals labeled Net +, Net -, and Shield.

NOTE: Use the same polarity throughout the network segment.

4. Insert the power screw terminal connector into the UPC Open controller's power terminals if they are not currently connected.
5. Verify communication with the network by viewing a module status report. To perform a module status report using the BACview keypad/display unit, press and hold the “FN” key then press the “.” Key.

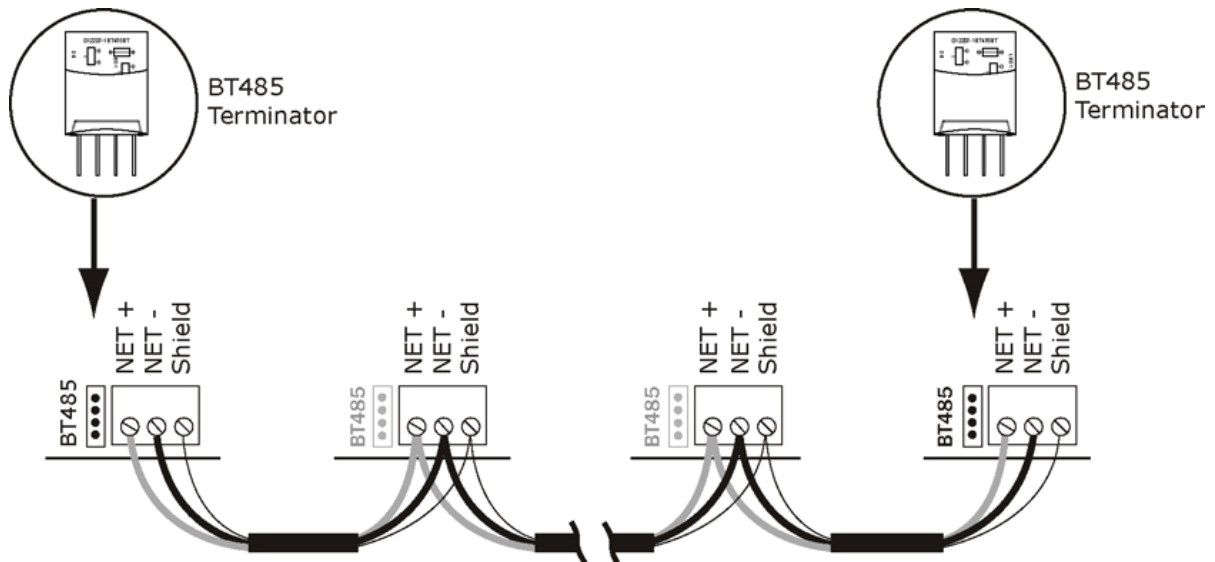

Fig. D — Network Wiring

APPENDIX H — BACNET COMMUNICATION OPTION (cont)

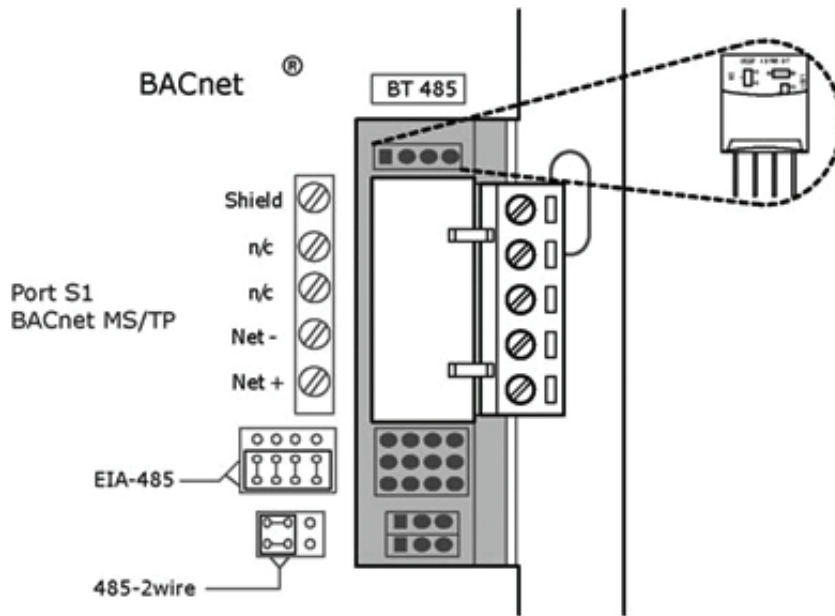

Fig. E — BT485 Terminator Installation

To install a BT485 terminator, push the BT485 terminator on to the BT485 connector located near the BACnet connector.
NOTE: The BT485 terminator has no polarity associated with it.

To order a BT485 terminator, consult Commercial Products i-Vu® Open Control System Master Prices.

MS/TP WIRING RECOMMENDATIONS — Recommendations are shown in Tables C and D. The wire jacket and UL

temperature rating specifications list two acceptable alternatives. The Halar specification has a higher temperature rating and a tougher outer jacket than the SmokeGard specification, and it is appropriate for use in applications where the user is concerned about abrasion. The Halar jacket is also less likely to crack in extremely low temperatures.

NOTE: Use the specified type of wire and cable for maximum signal integrity.

Table C — MS/TP Wiring Recommendations

SPECIFICATION	RECOMMENDATION
Cable	Single twisted pair, low capacitance, CL2P, 22 AWG (7x30), TC foam FEP, plenum rated cable
Conductor	22 or 24 AWG stranded copper (tin plated)
Insulation	Foamed FEP 0.015 in. (0.381 mm) wall 0.060 in. (1.524 mm) O.D.
Color Code	Black/White
Twist Lay	2 in. (50.8 mm) lay on pair 6 twists/foot (20 twists/meter) nominal
Shielding	Aluminum/Mylar shield with 24 AWG TC drain wire
Jacket	SmokeGard Jacket (SmokeGard PVC) 0.021 in. (0.5334 mm) wall 0.175 in. (4.445 mm) O.D. Halar Jacket (E-CTFE) 0.010 in. (0.254 mm) wall 0.144 in. (3.6576 mm) O.D.
DC Resistance	15.2 Ohms/1000 feet (50 Ohms/km) nominal
Capacitance	12.5 pF/ft (41 pF/meter) nominal conductor to conductor
Characteristic Impedance	100 Ohms nominal
Weight	12 lb/1000 feet (17.9 kg/km)
UL Temperature Rating	SmokeGard 167°F (75°C) Halar -40 to 302°F (-40 to 150°C)
Voltage	300 Vac, power limited
Listing	UL: NEC CL2P, or better

LEGEND

- AWG** — American Wire Gage
- CL2P** — Class 2 Plenum Cable
- DC** — Direct Current
- FEP** — Fluorinated Ethylene Polymer
- NEC** — National Electrical Code
- O.D.** — Outside Diameter
- TC** — Tinned Copper
- UL** — Underwriters Laboratories

APPENDIX H — BACNET COMMUNICATION OPTION (cont)

Table D — Open System Wiring Specifications and Recommended Vendors

WIRING SPECIFICATIONS		RECOMMENDED VENDORS AND PART NUMBERS			
Wire Type	Description	Connect Air International	Belden	RMCORP	Contractors Wire and Cable
MS/TP Network (RS-485)	22 AWG, single twisted shielded pair, low capacitance, CL2P, TC foam FEP, plenum rated. See MS/TP Installation Guide for specifications.	W221P-22227	—	25160PV	CLP0520LC
	24 AWG, single twisted shielded pair, low capacitance, CL2P, TC foam FEP, plenum rated. See MS/TP Installation Guide for specifications.	W241P-2000F	82841	25120-OR	—
Rnet	4 conductor, unshielded, CMP, 18 AWG, plenum rated.	W184C-2099BLB	6302UE	21450	CLP0442

LEGEND

- AWG** — American Wire Gage
- CL2P** — Class 2 Plenum Cable
- CMP** — Communications Plenum Rated
- FEP** — Fluorinated Ethylene Polymer
- TC** — Tinned Copper

LOCAL ACCESS TO THE UPC OPEN CONTROLLER — The user can use a BACview⁶ handheld keypad display unit or the Virtual BACview software as a local user interface to an Open controller. These items let the user access the controller network information. These are accessory items and do not come with the UPC Open controller.

The BACview⁶ unit connects to the local access port on the UPC Open controller. See Fig. F. The BACview software must be running on a laptop computer that is connected to the local access port on the UPC Open controller. The laptop will require an additional USB link cable for connection.

See the *BACview Installation and User Guide* for instructions on connecting and using the BACview⁶ device.

To order a BACview⁶ Handheld (BV6H), consult Commercial Products i-Vu Open Control System Master Prices.

CONFIGURING THE UPC OPEN CONTROLLER'S PROPERTIES — The UPC Open device and *ComfortLink* control must be set to the same CCN Address (Element) number and CCN Bus number. The factory default settings for CCN Element and CCN Bus number are 1 and 0 respectively.

If modifications to the default Element and Bus number are required, both the *ComfortLink* and UPC Open configurations must be changed.

The following configurations are used to set the CCN Address and Bus number in the *ComfortLink* control. These configurations can be changed using the scrolling marquee display or accessory Navigator handheld device.

Configuration → CCN → CCN.A (CCN Address)

Configuration → CCN → CCN.B (CCN Bus Number)

The following configurations are used to set the CCN Address and Bus Number in the UPC Open controller. These configurations can be changed using the accessory BACview⁶ display.

Navigation: BACview → CCN

Home: Element Comm Stat

Element: 1

Bus: 0

If the UPC Open controller is used with the chiller application of Lead/Lag/Standby, all chillers and UPC Open controller's CCN element numbers must be changed to a unique number in order to follow CCN specifications. In this application, there can only be a maximum of 3 UPC Open controllers on a CCN bus.

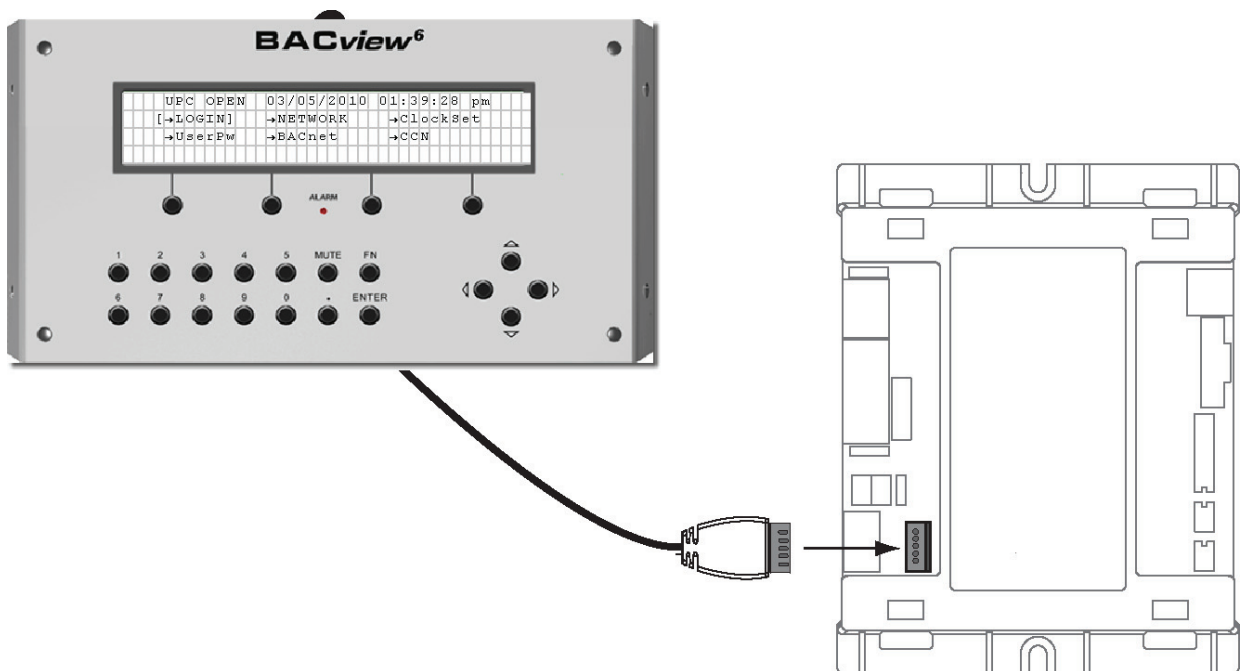

Fig. F — BACview⁶ Device Connection

APPENDIX H — BACNET COMMUNICATION OPTION (cont)

For the CCN Alarm Acknowledger configuration, the UPC Open controller defaults to CCN Acknowledger. If a Chiller Lead/Lag/Standby application is being used, then the Carrier technician must change the configuration to only one CCN Acknowledger on the CCN bus.

For the CCN Time Broadcaster configuration, the UPC Open controller defaults to CCN Time Broadcaster. If the Chiller Lead/Lag/Standby application is used, then the Carrier technician must change the configuration to only one CCN Time Broadcaster on the CCN bus.

TROUBLESHOOTING — If there are problems wiring or addressing the UPC Open controller, contact Carrier Technical Support.

COMMUNICATION LEDS — The LEDs indicate if the controller is communicating with the devices on the network. See Tables E and F. The LEDs should reflect communication traffic based on the baud rate set. The higher the baud rate the

more solid the LEDs become. See Fig. A for location of LEDs on UPC Open module.

REPLACING THE UPC OPEN BATTERY — The UPC Open controller's 10-year lithium CR2032 battery provides a minimum of 10,000 hours of data retention during power outages.

IMPORTANT: Power must be **ON** to the UPC Open controller when replacing the battery, or the date, time, and trend data will be lost.

Remove the battery from the controller, making note of the battery's polarity. Insert the new battery, matching the battery's polarity with the polarity indicated on the UPC Open controller.

NETWORK POINTS LIST — The points list for the controller is shown in Table G.

Table E — LED Status Indicators

LED	STATUS
Power	Lights when power is being supplied to the controller. The UPC Open controller is protected by internal solid-state polyswitches on the incoming power and network connections. These polyswitches are not replaceable and will reset themselves if the condition that caused the fault returns to normal.
Rx	Lights when the controller receives data from the network segment; there is an Rx LED for Ports 1 and 2.
Tx	Lights when the controller transmits data to the network segment; there is an Rx LED for Ports 1 and 2.
Run	Lights based on controller status. See Table F.
Error	Lights based on controller status. See Table F.

Table F — Run and Error LEDs Controller and Network Status Indication

RUN LED	ERROR LED	STATUS
2 flashes per second	Off	Normal
2 flashes per second	2 flashes, alternating with Run LED	Five minute auto-restart delay after system error
2 flashes per second	3 flashes, then off	Controller has just been formatted
2 flashes per second	1 flash per second	Controller is alone on the network
2 flashes per second	On	Exec halted after frequent system errors or control programs halted
5 flashes per second	On	Exec start-up aborted, Boot is running
5 flashes per second	Off	Firmware transfer in progress, Boot is running
7 flashes per second	7 flashes per second, alternating with Run LED	Ten second recovery period after brownout
14 flashes per second	14 flashes per second, alternating with Run LED	Brownout

APPENDIX H — BACNET COMMUNICATION OPTION (cont)

Table G — Network Points List

POINT DESCRIPTION	CCN POINT NAME	READ/WRITE	UNITS	DEFAULT VALUE	RANGE	BACNET OBJECT ID	BACNET OBJECT NAME
4-20 ma Cooling Setpoint	CSP_IN	R	mA		nn.n	AV:4	csp_in_1
4-20 ma Demand Signal	LMT_MA	R	mA		nn.n	AV:5	lmt_ma_1
4-20 ma Heating Setpoint	HSP_IN	R	mA		nn.n	AV:6	hsp_in_1
4-20 ma Reset Signal	RST_MA	R	mA		nn.n	AV:7	rst_ma_1
A1 Motor Temperature	TMTR_A1	R	°F		nnn.n	AV:8	tmtr_a1_1
A1 Oil Filter Diff.Press	FLTP_A1	R	PSI		nnn.n	AV:9	fltp_a1_1
A1 Oil Pressure	OP_A1	R	PSIG		nnn.n	AV:10	op_a1_1
A1 Oil Pressure Diff.	DOP_A1	R	PSI		nnn.n	AV:11	dop_a1_1
A2 Motor Temperature	TMTR_A2	R	°F		nnn.n	AV:12	tmtr_a2_1
A2 Oil Filter Diff.Press	FLTP_A2	R	PSI		nnn.n	AV:13	fltp_a2_1
A2 Oil Pressure	OP_A2	R	PSIG		nnn.n	AV:14	op_a2_1
A2 Oil Pressure Diff.	DOP_A2	R	PSI		nnn.n	AV:15	dop_a2_1
Active Demand Limit	DEM_LIM	R/W	%		0 to 100	AV:16	dem_lim_1
Active Setpoint	SP	R	°F		snnn.n	AV:17	sp_1
Alarm Relay Usage	ALRMCNFG	R		Alerts and Alarms	0=Alerts and Alarms 1=AlarmsOnly 2=Off	AV:18	alrmcnfg_1
Alarm State	ALM	R			0=Normal 1=Alert 2=Alarm	AV:19	alm_1
					1=Normal 2=Alert 3=Alarm	MSV:2	alm_msv_1
Approach Setpoint	APRCH_SP	R	°F	3.0	0.1 to 20.0	AV:20	aprch_sp_1
B1 Motor Temperature	TMTR_B1	R	°F		nnn.n	AV:21	tmtr_b1_1
B1 Oil Filter Diff.Press	FLTP_B1	R	PSI		nnn.n	AV:22	fltp_b1_1
B1 Oil Pressure	OP_B1	R	PSI		nnn.n	AV:23	op_b1_1
B1 Oil Pressure Diff.	DOP_B1	R	PSI		nnn.n	AV:24	dop_b1_1
B2 Motor Temperature	TMTR_B2	R	°F		nnn.n	AV:25	tmtr_b2_1
B2 Oil Filter Diff.Press	FLTP_B2	R	PSI		nnn.n	AV:26	fltp_b2_1
B2 Oil Pressure	OP_B2	R	PSI		nnn.n	AV:27	op_b2_1
B2 Oil Pressure Diff.	DOP_B2	R	PSI		nnn.n	AV:28	dop_b2_1
Calculated MOP Circuit A	MOP_SPA	R	°F		nn.n	AV:29	mop_spa_1
Calculated MOP Circuit B	MOP_SPB	R	°F		nn.n	AV:30	mop_spb_1
CCN Chiller	CHIL_S_S	R/W			Start/Stop	BV:3	chil_s_s_1
CCN Loadshed Signal	DL_STAT	R			0=Normal 1=Readline 2=Loadshed	AV:31	dl_stat_1
Circuit A - Pumping out	MODE_27	R			On/Off	BV:4	mode_27_1
Circuit A Run Hours	HR_CIRA	R	hr		nnnnnn	AV:32	hr_cira_1
Circuit A Starts	CY_CIRA	R	hr		nnnnnn	AV:33	cy_cira_1
Circuit B - Pumping out	MODE_28	R			On/Off	BV:5	mode_28_1
Circuit B Run Hours	HR_CIRB	R	hr		nnnnnn	AV:34	hr_cirb_1
Circuit B Starts	CY_CIRB	R	hr		nnnnnn	AV:35	cy_cirb_1
Circuit Running Current	A_CURR	R	A		0 to 1200	AV:36	a_curr_1
Circuit Running Current	B_CURR	R	A		0 to 1200	AV:37	b_curr_1
Ckt A Off Ref Flow Delay	MODE_25	R			On/Off	BV:6	mode_25_1
Ckt B Off Ref Flow Delay	MODE_26	R			On/Off	BV:7	mode_26_1
Close Control Select	CLS_CTRL	R		Disable	Disable/Enable	BV:8	cls_ctrl_1
Comp A1 % Must Trip Amps	A1_MTA	R	%		0 to 100	AV:38	a1_mta_1
Comp A1 Running Current	A1_CURR	R	A		0 to 600	AV:39	a1_curr_1
Comp A2 % Must Trip Amps	A2_MTA	R	%		0 to 100	AV:40	a2_mta_1
Comp A2 Running Current	A2_CURR	R	A		0 to 600	AV:41	a2_curr_1
Comp B1 % Must Trip Amps	B1_MTA	R	%		0 to 100	AV:42	b1_mta_1
Comp B1 Running Current	B1_CURR	R	A		0 to 600	AV:43	b1_curr_1
Comp B2 % Must Trip Amps	B2_MTA	R	%		0 to 100	AV:44	b2_mta_1
Comp B2 Running Current	B2_CURR	R	A		0 to 600	AV:45	b2_curr_1

LEGEND

R — Read
W — Write

APPENDIX H — BACNET COMMUNICATION OPTION (cont)

Table G — Network Points List (cont)

POINT DESCRIPTION	CCN POINT NAME	READ/ WRITE	UNITS	DEFAULT VALUE	RANGE	BACNET OBJECT ID	BACNET OBJECT NAME
Compressor A1 Feedback	K_A1_FBK	R			On/Off	BV:9	k_a1_fbk_1
Compressor A1 Relay	K_A1_RLY	R			On/Off	BV:10	k_a1_rly_1
Compressor A1 Run Hours	HR_A1	R	hr		nnnnnn	AV:46	hr_a1_1
Compressor A1 Starts	CY_A1	R			nnnnnn	AV:47	cy_a1_1
Compressor A2 Feedback	K_A2_FBK	R			On/Off	BV:11	k_a2_fbk_1
Compressor A2 Relay	K_A2_RLY	R			On/Off	BV:12	k_a2_rly_1
Compressor A2 Run Hours	HR_A2	R	hr		nnnnnn	AV:48	hr_a2_1
Compressor A2 Starts	CY_A2	R			nnnnnn	AV:49	cy_a2_1
Compressor B1 Feedback	K_B1_FBK	R			On/Off	BV:13	k_b1_fbk_1
Compressor B1 Relay	K_B1_RLY	R			On/Off	BV:14	k_b1_rly_1
Compressor B1 Run Hours	HR_B1	R	hr		nnnnnn	AV:50	hr_b1_1
Compressor B1 Starts	CY_B1	R			nnnnnn	AV:51	cy_b1_1
Compressor B2 Feedback	K_B2_FBK	R			On/Off	BV:15	k_b2_fbk_1
Compressor B2 Relay	K_B2_RLY	R			On/Off	BV:16	k_b2_rly_1
Compressor B2 Run Hours	HR_B2	R	hr		nnnnnn	AV:52	hr_b2_1
Compressor B2 Starts	CY_B2	R			nnnnnn	AV:53	cy_b2_1
Compressor Sequence	COMP_SEQ	R/W		Compressor 1 Leads	0=Automatic 1=Compressor 1 Leads 2=Compressor 2 Leads	AV:54	comp_seq_1
Condenser Entering Fluid	COND_EWT	R	°F		snnn.n	AV:55	cond_ewt_1
Condenser Flow Switch	CONDFLOW	R			On/Off	BV:17	condflow_1
Condenser Fluid Sensors	CD_TEMP	R		No	No/Yes	BV:18	cd_temp_1
Condenser Leaving Fluid	COND_LWT	R	°F		snnn.n	AV:56	cond_lwt_1
Condenser Pump Control	CNPC	R		Not Controlled	0=NotControlled 1=On when STATE is On 2=On when compressors are on	AV:57	cnpc_1
Condenser Pump Interlock	CND_LOCK	R		Off	Off/On	BV:19	cnd_lock_1
Condenser Pump Relay	COND_PMP	R			On/Off	BV:20	cond_pmp_1
Control Mode	STAT	R			0=Service Test 1=Off-Local 2=Off-CCN 3=Off-Clock 4=Off-Emergency 5=On-Local 6=On-CCN 7=On-Clock	AV:58	stat_1
					1=Service Test 2=Off-Local 3=Off-CCN 4=Off-Clock 5=Off-Emergency 6=On-Local 7=On-CCN 8=On-Clock	MSV:5	stat_msv_1
Control Point	CTRL_PNT	R/W	°F		snn.n	AV:59	ctrl_pnt_1
Cool Entering Fluid-Slave	COOLEWTS	R	°F		snnn.n	AV:60	coolewts_1
Cool Leaving Fluid-Slave	COOLLWTS	R	°F	44.0	-20 to 70	AV:66	coollwts_1
Cooler Entering Fluid	COOL_EWT	R	°F		snnn.n	AV:61	cool_ewt_1
Cooler Flow Switch	COOLFLOW	R			On/Off	BV:21	coolflow_1
Cooler Fluid	FLUIDTYP	R			1=Water 2=MediumBrine 3=Low Brine	MSV:6	fluidtyp_msv_1
Cooler Freeze Protection	MODE_16	R			On/Off	BV:22	mode_16_1
Cooler Heater	COOL_HTR	R			On/Off	BV:23	cool_htr_1
Cooler Leaving Fluid	COOL_LWT	R	°F		snnn.n	AV:62	cool_lwt_1
Cooler Pump Control	CPC	R		Off	Off/On	BV:24	cpc_1
Cooler Pump Relay	COOL_PMP	R			On/Off	BV:25	cool_pmp_1
Cooling Ramp Loading	CRAMP	R/W	°F		snnn.n	AV:63	cramp_1

LEGEND

R — Read
W — Write

APPENDIX H — BACNET COMMUNICATION OPTION (cont)

Table G — Network Points List (cont)

POINT DESCRIPTION	CCN POINT NAME	READ/ WRITE	UNITS	DEFAULT VALUE	RANGE	BACNET OBJECT ID	BACNET OBJECT NAME
Cooling Setpoint 1	CSP1	R/W		1.0	.02 to 2.0	AV:64	csp1_1
Cooling Setpoint 2	CSP2	R/W	°F	44.0	-20 to 70	AV:65	csp2_1
CSM Controlling Chiller	MODE_1	R			On/Off	BV:26	mode_1_1
Current Unbalance SetPnt	CUR_TRIP	R	%	10	10 to 25	AV:67	cur_trip_1
Deadband Multiplier	Z_GAIN	R		2.0	1.0 to 4.0	AV:68	z_gain_1
Demand Level 1		R	%		0 to 100	AV:1	dmv_lvl_1_perct_1
Demand Level 2		R	%		0 to 100	AV:2	dmv_lvl_2_perct_1
Demand Level 3		R	%		0 to 100	AV:3	dmv_lvl_3_perct_1
Demand Limit at 20 mA	DMT20MA	R	%	100	0 to 100	AV:69	dmt20ma_1
Demand Limit In Effect	MODE_15	R			On/Off	BV:27	mode_15_1
Demand Limit Switch 1	DMD_SW1	R			On/Off	BV:28	dmd_sw1_1
Demand Limit Switch 2	DMD_SW2	R			On/Off	BV:29	dmd_sw2_1
Discharge Gas Temp	DISTMP_A	R	°F		nnn.n	AV:70	distmp_a_1
Discharge Gas Temp	DISTMP_B	R	°F		nnn.n	AV:71	distmp_b_1
Discharge Gas Temp - A1	DISTMPA1	R	°F		nnn.n	AV:72	distmpa1_1
Discharge Gas Temp - A2	DISTMPA2	R	°F		nnn.n	AV:73	distmpa2_1
Discharge Gas Temp - B1	DISTMPB1	R	°F		nnn.n	AV:74	distmpb1_1
Discharge Gas Temp - B2	DISTMPB2	R	°F		nnn.n	AV:75	distmpb2_1
Discharge Pressure	DP_A	R	PSI		nnn.n	AV:76	dp_a_1
Discharge Pressure	DP_B	R	PSI		nnn.n	AV:77	dp_b_1
Discharge Superheat Temp	SH_A	R	°F		nnn.n	AV:78	sh_a_1
Discharge Superheat Temp	SH_B	R	°F		nnn.n	AV:79	sh_b_1
Dual Chill Lag CapLimit	DCLGCAPL	R	%		0 to 100	AV:82	dclgcapl_1
Dual Chill Lead Cap Limit	DCLDCAPL	R	%		0 to 100	AV:83	dcldcapl_1
Dual Chill Pct Avail Cap	CAPA_DPX	R	%		nnn	AV:84	capa_dpx_1
Dual Chill Pct Total Cap	CAPT_DPX	R	%		nnn	AV:85	capt_dpx_1
Dual Chiller Link Good ?	DC_LINK	R			Yes/No	BV:30	dc_link_1
Dual Chiller Size	SIZE_DPX	R	tons		0 to 100	AV:80	size_dpx_1
Dual Chiller Tons Avail	SIZEADPX	R	tons		0 to 100	AV:81	sizeadpx_1
Dual Setpoint	MODE_13	R			On/Off	BV:31	mode_13_1
Dual Setpoint Switch	DUAL_IN	R			On/Off	BV:32	dual_in_1
Economizer Pressure	ECNP_A	R	PSI		nnn.n	AV:86	ecnp_a_1
Economizer Pressure	ECNP_B	R	PSI		nnn.n	AV:87	ecnp_b_1
Element Comm Status		R			No Comm/Normal	BV:2999	element_stat_1
Element Communications Alarm		R			Comm Normal/ Comm Lost	BV:97	comm_lost_alm_1
Emergency Stop	EMSTOP	R			Enable/Emstop	BV:33	emstop_1
EMM Module installed	EMM_BRD	R		No	No/Yes	BV:34	emm_brd_1
Enable No Flow Detection	NOFLOWEN	R		Enable	Disable/Enable	BV:35	noflowen_1
Entering Fluid Temp	EWT	R	°F		snnn.n	AV:88	ewt_1
Equipment Alarm		R			Normal/Alarm	BV:118	element_alarm_1
EXV % Open	EXV_A	R	%		0 to 100	AV:89	exv_a_1
EXV % Open	EXV_B	R	%		0 to 100	AV:90	exv_b_1
Fan 1 Relay	FAN_1	R			On/Off	BV:36	fan_1_1
Fan 2 Relay	FAN_2	R			On/Off	BV:37	fan_2_1
Fan 3 Relay	FAN_3	R			On/Off	BV:38	fan_3_1
Fan 4 Relay	FAN_4	R			On/Off	BV:39	fan_4_1
Head Press. Control Type	HEAD_TYP	R		None	0=None 1=Air Cooled 2=Water Cooled 3=Common Condenser 4=Independent Condenser	AV:91	head_typ_1

LEGEND

R — Read
W — Write

APPENDIX H — BACNET COMMUNICATION OPTION (cont)

Table G — Network Points List (cont)

POINT DESCRIPTION	CCN POINT NAME	READ/ WRITE	UNITS	DEFAULT VALUE	RANGE	BACNET OBJECT ID	BACNET OBJECT NAME
Head Pressure Setpoint A	HSP_A	R/W	°F	113	80 to 140	AV:92	hsp_a_1
Head Pressure Setpoint B	HSP_B	R/W	°F	113	80 to 140	AV:93	hsp_b_1
Heat Cool Select	HEATCOOL	R			Heat/Cool	BV:40	heatcool_1
Heating Ramp Loading	HRAMP	R		1.0	.02 to 2.0	AV:94	hramp_1
Heating Setpoint 1	HSP1	R	°F	100	80 to 140	AV:95	hsp1_1
Heating Setpoint 2	HSP2	R	°F	100	80 to 140	AV:96	hsp2_1
Hi Tmp Cool/Lo Tmp Heat	MODE_18	R			On/Off	BV:45	mode_18_1
High Motor Current Cir.A	MODE_23	R			On/Off	BV:41	mode_23_1
High Motor Current Cir.B	MODE_24	R			On/Off	BV:42	mode_24_1
High SCT Circuit A	MODE_21	R			On/Off	BV:43	mode_21_1
High SCT Circuit B	MODE_22	R			On/Off	BV:44	mode_22_1
Ice Done	ICE	R			Yes/No	BV:46	ice_1
Ice Mode Enable	ICE_CNFG	R		Disable	Disable/Enable	BV:47	ice_cnfg_1
Ice Setpoint	CSP3	R/W	°F	32.0	-20 to 32	AV:97	csp3_1
Lag Chiller Ctrl Point	LAG_CP	R	°F		snnn.n	AV:98	lag_cp_1
Lag Commanded Off?	LAG_OFF	R			Yes/No	BV:48	lag_off_1
Lag- SMZ Clear Commanded	LAG_SMZC	R			Yes/No	BV:49	lag_smzc_1
Lag Start Delay	LL_DELAY	R	min	5	0 to 30	AV:99	ll_delay_1
Lead Chiller Ctrl Point	LEAD_CP	R		Circuit A leads	0=Automatic 1=Circuit A leads 2=Circuit B leads	AV:104	lead_cp_1
Lead SMZ Clear Commanded	LEADSMZC	R		Disable	Disable/Enable	BV:51	leadsmzc_1
Lead/Lag Balance Delta	LL_BAL_D	R	°F		snnn.n	AV:100	ll_bal_d_1
Lead/Lag Balance Select	LL_BAL	R	hrs	168	40 to 400	AV:101	ll_bal_1
Lead/Lag Chiller Enable	LL_ENA	R			Yes/No	BV:50	ll_ena_1
Lead/Lag Leaving Fluid	DUAL_LWT	R		Master Leads	0=MasterLeads 1=SlaveLeads 2=Automatic	AV:102	dual_lwt_1
Lead/Lag Sequence Select	LEAD_TYPE	R/W	°F		snnn.n	AV:103	lead_type_1
Leaving Fluid Temp - Prime Variable	LWT	R	°F		snnn.n	AV:105	lwt_1
Liq. Line Solenoid Valve	LLSV	R			Open/Close	BV:52	llsv_1
Lo Tmp Cool/Hi Tmp Heat	MODE_17	R			On/Off	BV:57	mode_17_1
Load/Unload Factor	SMZ	R			snnn.n	AV:106	smz_1
Load/Unload Factor-Slave	SMZSLAVE	R			snnn.n	AV:107	smzslave_1
Loader A1 Relay	LOADR_A1	R			On/Off	BV:53	loadr_a1_1
Loader A2 Relay	LOADR_A2	R			On/Off	BV:54	loadr_a2_1
Loader B1 Relay	LOADR_B1	R			On/Off	BV:55	loadr_b1_1
Loader B2 Relay	LOADR_B2	R			On/Off	BV:56	loadr_b2_1
Loading Sequence Select	SEQ_TYPE	R/W		Equal loading	1=Equalloading 2=Staged loading	AV:108	seq_type_1
Loadshed Demand Delta	SHED_DEL	R	%	0	0 to 60	AV:109	shed_del_1
Loadshed Group Number	SHED_NUM	R		0	0 to 99	AV:110	shed_num_1
Local Schedule		R			On/Off	BV:1	schedule_1
Low Cooler Suction Temp A	MODE_7	R			On/Off	BV:58	mode_7_1
Low Cooler Suction Temp B	MODE_8	R			On/Off	BV:59	mode_8_1
Low Dischrge Superheat A	MODE_11	R			On/Off	BV:60	mode_11_1
Low Dischrge Superheat B	MODE_12	R			On/Off	BV:61	mode_12_1
Low Source Protection	MODE_4	R			On/Off	BV:62	mode_4_1
Machine Operating Hours	HR_MACH	R	hr		nnnnnn	AV:111	hr_mach_1
Machine Starts	CY_MACH	R			nnnnnn	AV:112	cy_mach_1
Making ICE	MODE_19	R			On/Off	BV:63	mode_19_1
Master/Slave Control	MODE_3	R			On/Off	BV:64	mode_3_1
Master/Slave Select	MS_SEL	R		Master	Slave/Master	BV:65	ms_sel_1
Maximum Loadshed Time	SHED_TIM	R	min	60	0 to 120	AV:113	shed_tim_1
Min.Load Valve Select	MLV_FLG	R		No	No/Yes	BV:66	mlv_flg_1

LEGEND

R — Read
W — Write

APPENDIX H — BACNET COMMUNICATION OPTION (cont)

Table G — Network Points List (cont)

POINT DESCRIPTION	CCN POINT NAME	READ/ WRITE	UNITS	DEFAULT VALUE	RANGE	BACNET OBJECT ID	BACNET OBJECT NAME
Minimum Load Valve	MLV	R			On/Off	BV:67	mlva_1
Minimum Load Valve	MLV	R			On/Off	BV:68	mlvb_1
Minimum OFF Time Active	MODE_10	R			On/Off	BV:69	mode_10_1
Minutes Off Time	DELAY	R/W	min	0	0 to 15	AV:114	delay_1
Motor Cooling A1 Solenoid	MTRCL_A1	R			On/Off	BV:70	mtrcl_a1_1
Motor Cooling A2 Solenoid	MTRCL_A2	R			On/Off	BV:71	mtrcl_a2_1
Motor Cooling B1 Solenoid	MTRCL_B1	R			On/Off	BV:72	mtrcl_b1_1
Motor Cooling B2 Solenoid	MTRCL_B2	R			On/Off	BV:73	mtrcl_b2_1
Occupied	OCC	R			Yes/No	BV:74	occ_1
Oil Filter Delta P Setpt	FP_SP	R	PSI			AV:115	fp_sp_1
Oil Heater	OILA_HTR	R			On/Off	BV:75	oila_htr_1
Oil Heater	OILB_HTR	R			On/Off	BV:76	oilb_htr_1
Oil Level Switch	OILA_SW	R			Close/Open	BV:77	oila_sw_1
Oil Level Switch	OILB_SW	R			Close/Open	BV:78	oilb_sw_1
Oil Pump	OILPMP_A	R			On/Off	BV:79	oilpmp_a_1
Oil Pump	OILPMP_B	R			On/Off	BV:80	oilpmp_b_1
Oil Solenoid A1	OILSL_A1	R			On/Off	BV:81	oilsl_a1_1
Oil Solenoid A2	OILSL_A2	R			On/Off	BV:82	oilsl_a2_1
Oil Solenoid B1	OILSL_B1	R			On/Off	BV:83	oilsl_b1_1
Oil Solenoid B2	OILSL_B2	R			On/Off	BV:84	oilsl_b2_1
Outside Air Temperature	OAT	R/W	°F		snnn.n	AV:116	oat_1
Override Modes in Effect	MODE	R			Yes/No	BV:85	mode_1
Parallel Configuration	PARALLEL	R		No	Yes/No	BV:86	parallel_1
Percent Avail.Capacity	CAP_A	R	%		0 to 100	AV:117	cap_a_1
Percent Available Cap.	CAPA_A	R	%		0 to 100	AV:118	capa_a_1
Percent Available Cap.	CAPB_A	R	%		0 to 100	AV:119	capb_a_1
Percent Total Capacity	CAP_T	R	%		0 to 100	AV:120	cap_t_1
Percent Total Capacity	CAPA_T	R	%		0 to 100	AV:121	capa_t_1
Percent Total Capacity	CAPB_T	R	%		0 to 100	AV:122	capb_t_1
Pressure Transducers	PRESS_TY	R		Yes	No/Yes	BV:87	press_ty_1
Ramp Load Limited	MODE_5	R			On/Off	BV:88	mode_5_1
Ramp Load Select	RAMP_EBL	R/W		Enable	Disable/Enable	BV:89	ramp_ebl_1
Remote - Degrees Reset	HREM_DEG	R	^F	0	-30 to 30	AV:123	hrem_deg_1
Remote - Full Reset Temp	HREM_FUL	R	dF	80	0 to 125	AV:124	hrem_ful_1
Remote - No Reset Temp	HREM_NO	R	dF	50	0 to 10	AV:125	hrem_no_1
Return - Degrees Reset	HRTN_DEG	R	^F	0	-30 to 30	AV:126	hrtn_deg_1
Return - Full Reset Temp	HRTN_FUL	R	^F	0	0 to 30	AV:127	hrtn_ful_1
Return - No Reset Temp	HRTN_NO	R	^F	10	0 to 10	AV:128	hrtn_no_1
Saturated Condensing Tmp	TMP_SCTA	R	°F		snnn.n	AV:129	tmp_scta_1
Saturated Condensing Tmp	TMP_SCTB	R	°F		snnn.n	AV:130	tmp_sctb_1
Saturated Suction Temp	TMP_SSTA	R	°F		snnn.n	AV:131	tmp_ssta_1
Saturated Suction Temp	TMP_SSTB	R	°F		snnn.n	AV:132	tmp_sstb_1
Slave Address	SLV_ADDR	R		2	0 to 239	AV:133	slv_addr_1
Slow Change Override	MODE_9	R			On/Off	BV:90	mode_9_1
Space Temperature	SPT	R/W	°F		snnn.n	AV:134	spt_1
Storing ICE	MODE_20	R			On/Off	BV:91	mode_20_1
Suction Pressure	SP_A	R	PSI		nnn.n	AV:135	sp_a_1
Suction Pressure	SP_B	R	PSI		nnn.n	AV:136	sp_b_1
System Cooling Demand Level		R				AV:9006	cool_demand_level_1
System Demand Limiting		R			Inactive/Active	BV:2	dem_lmt_act_1
Temperature Reset	MODE_14	R			On/Off	BV:92	mode_14_1
Timed Override In Effect	MODE_6	R			On/Off	BV:93	mode_6_1
Unit Off: No Water Flow	MODE_29	R			On/Off	BV:94	mode_29_1

LEGEND

R — Read
W — Write

APPENDIX H — BACNET COMMUNICATION OPTION (cont)

Table G — Network Points List (cont)

POINT DESCRIPTION	CCN POINT NAME	READ/ WRITE	UNITS	DEFAULT VALUE	RANGE	BACNET OBJECT ID	BACNET OBJECT NAME
User Defined Analog 1		R				AV:2901	user_analog_1_1
User Defined Analog 2		R				AV:2902	user_analog_2_1
User Defined Analog 3		R				AV:2903	user_analog_3_1
User Defined Analog 4		R				AV:2904	user_analog_4_1
User Defined Analog 5		R				AV:2905	user_analog_5_1
User Defined Binary 1		R				BV:2911	user_binary_1_1
User Defined Binary 2		R				BV:2912	user_binary_2_1
User Defined Binary 3		R				BV:2913	user_binary_3_1
User Defined Binary 4		R				BV:2914	user_binary_4_1
User Defined Binary 5		R				BV:2915	user_binary_5_1
Var Head Pressure Select	VHPTYPE	R			0=None 1=4-20mA 2=0-20mA 3=20-0mA	AV:137	vhptype_1
Variable Head Press Pct.	VHPA	R	%		0 to 100	AV:138	vhpa_1
Variable Head Press Pct.	VHPB	R	%		0 to 100	AV:139	vhpb_1
Winterize Alert Config	WINTMSG	R		Enable	Disable/Enable	BV:95	wintmsg_1
WSM Controlling Chiller	MODE_2	R			On/Off	BV:96	mode_2_1

LEGEND

R — Read
W — Write

START-UP CHECKLIST FOR 30HX LIQUID CHILLER

I. Project Information

Job Name _____

Address _____

City _____ State _____ Zip _____

Installing Contractor _____

Sales Office _____

Equipment

Model _____ Serial _____

→ II. Preliminary Equipment Check (to be completed by installing contractor)

Is there any physical damage? Yes No

If yes, was it noted on the freight bill and
has a claim been filed with the shipper? Yes No

Will this prevent start-up? Yes No

Description _____

1. Unit is installed level as per the installation instructions. Yes No

2. Power supply agrees with the unit nameplate. Yes No

3. Correct control voltage _____ vac. Yes No

NOTE: Units with a power supply of 230 (60 Hz), 208/230, 460, or
575-3-60 require a separate 115-1-60 control circuit power supply.

4. Electrical power wiring is installed properly. (Branch circuit fused
or HACR breaker) Yes No

5. Unit is properly grounded. Yes No

6. Electrical circuit protection has been sized and installed properly. Yes No

7. Mechanical room maintained above 50 F (10 C). Yes No

8. Relief valve vent piping installed per local codes. Yes No

9. Wind baffles installed (09AZ, 09DK, 09DP). Yes No

NOTE: Required for unit operation where winds of 5 mph (2.2 m/s) or
greater are anticipated at outdoor ambient temperatures below 32 F (0° C).

Chilled Water System Check (to be completed by installing contractor)

- 1. All chilled water valves are open. Yes No
- 2. All piping is connected properly. Yes No
- 3. All air has been purged from the system. Yes No
- 4. Chilled water pump is operating with the correct rotation. Yes No
- 5. Chilled water pump starter interlocked with chiller. Yes No
- 6. Inlet piping to cooler includes a 20 mesh strainer. Yes No
- 7. Water loop volume greater than 3 gal/ton for air conditioning or 6 gal/ton for process cooling and low ambient operation. Yes No
- 8. Proper loop freeze protection provided to ____ °F (°C). Yes No

Antifreeze type _____ Concentration _____%.

(If antifreeze solution is not utilized on 30HXA machines and the minimum outdoor ambient is below 32 F (0° C) then item 10 must be completed to provide cooler freeze protection. Refer to Installation Instructions for proper cooler winterization procedure.)

- 9. Cooler heads and tube sheets are insulated. Yes No
- 10. Chilled water pump controlled by chiller. Yes No
If yes, have the pump interlocks been wired? Yes No
(Chilled water pump will start automatically to circulate water through cooler during potential freezing conditions.)
- 11. Are there any VFDs on the chilled water pumps? Yes No
Primary loop Yes No
Secondary loop Yes No

Condenser Water System Check (30HXC Only)

- 1. All condenser water valves are open. Yes No
- 2. All piping is connected properly. Yes No
- 3. All air has been purged from the system. Yes No
- 4. Condenser water pump is operating with the correct rotation. Yes No
- 5. Condenser water pump controlled by chiller. Yes No
- 6. Inlet piping to condenser includes a 20 mesh strainer. Yes No
- 7. Condenser water flow switch installed. (Required for 30HXC Brine.) Yes No
- 8. Condenser water flow switch configured and operational. Yes No
- 9. Condenser water control valve installed. Yes No
(Separate control power required.)

CUT ALONG DOTTED LINE

CUT ALONG DOTTED LINE

Remote Condenser System Check (30HXA Only)

- 1. All refrigerant piping is connected properly. Yes No
- 2. Equalizer line is installed from motor cooling line to back-pressure valve. Yes No
- 3. Liquid line filter driers installed. Yes No
- 4. Liquid line solenoid valves installed. Yes No
- 5. R-134a fan cycling pressure switches installed (09AZ, 09DK, 09DP). Yes No
- 6. Refrigerant piping and condenser have been leak checked and evacuated. Yes No

SIGNATURE REQUIRED

Preliminary start-up complete.

Installing/mechanical contractor _____ Date _____

→ **III. Unit Start-Up (Mandatory Factory [CCS] Start-Up Required!)**

- 1. All liquid line valves are open. Yes No
- 2. All discharge valves are open. Yes No
- 3. All suction service valves are open (if equipped). Yes No
- 4. All oil line valves are open. Yes No
- 5. Liquid line solenoid valves with manual lift stems have been checked for proper position. Yes No
- 6. Chilled water flow switch is operational. Yes No
- 7. Leak check unit. Locate, repair and report any refrigerant leaks. Yes No
- 8. Voltage is within unit nameplate range. Yes No
- 9. Check voltage imbalance: A-B _____ A-C _____ B-C _____
Average voltage = _____ (A-B + A-C + B-C)/3
Maximum deviation from average voltage = _____
Voltage imbalance = _____% (max. deviation/average voltage) x 100
Voltage imbalance less than 2%. Yes No
(DO NOT start chiller if voltage imbalance is greater than 2%.
Contact local Utility for assistance.)
- 10. All terminals are tight. Yes No
- 11. All plug assemblies are tight. Yes No
- 12. All cables and thermistors have been inspected for crossed wires. Yes No
- 13. All thermistors are fully inserted into wells. Yes No
- 14. Verify cooler flow rate (maximum and minimum) Yes No
 - Pressure entering cooler _____ psig (kpa)
 - Pressure leaving cooler _____ psig (kpa)
 - Cooler pressure drop _____ psig (kpa)
 - Psig x 2.31 ft/psi = _____ ft of water
 - Kpa x 0.334 m/psi = _____ m of water

III. Unit Start-Up (cont)

15. Verify condenser flow rate. Yes No
- Maximum cooler flow rate _____ gpm (l/s) (See Cooler Pressure Drop Curve)
- Minimum cooler flow rate _____ gpm (l/s) (See Cooler Pressure Drop Curve)
- Pressure entering condenser _____ psig (kpa)
- Pressure leaving condenser _____ psig (kpa)
- Condenser pressure drop _____ psig (kpa)
- Psig x 2.31 ft/psi = _____ ft of water
- Kpa x 0.334 m/psi = _____ m of water
- Condenser flow rate _____ gpm (l/s) (See Condenser Pressure Drop Curve)

Start and operate machine. Complete the following:

1. Complete component test. Yes No
2. Check refrigerant and oil charge. Record charge information. Yes No
3. Record compressor motor current. Yes No
4. Record two sets of operational log readings. Yes No
5. Provide operating instructions to owner's personnel. Instruction time _____ hrs.

IMPORTANT: For 30HXC,HXA units utilizing brine, the unit may require more refrigerant than what was supplied.

Refrigerant Charge Circuit A _____ Circuit B _____

Additional charge required _____ _____

Oil Charge

Additional charge required _____ _____

ALL UNITS:

Record the following information from the Pressures and Temperatures Modes when machine is in a stable operation condition.

COOLER ENTERING FLUID _____

COOLER LEAVING FLUID _____

OUTSIDE AIR TEMPERATURE _____

SPACE TEMPERATURE _____

CONDENSER ENTERING FLUID _____

CONDENSER LEAVING FLUID _____

LEAD/LAG LEAVING FLUID _____

	CIRCUIT A	CIRCUIT B
SATURATED CONDENSING TEMP	_____	_____
SATURATED SUCTION TEMP	_____	_____
DISCHARGE SUPERHEAT TEMP (Comp 1/Comp 2)	_____	_____
MOTOR TEMPERATURE (Comp 1/Comp 2)	_____	_____
DISCHARGE PRESSURE	_____	_____
SUCTION PRESSURE	_____	_____
ECONOMIZER PRESSURE	_____	_____
OIL PRESSURE (Comp 1/Comp 2)	_____	_____
OIL PRESSURE DIFF. (Comp 1/Comp 2)	_____	_____
OIL FILTER DIFF. (Comp 1/Comp 2)	_____	_____
CALCULATED OIL PRESS (Comp 1/Comp 2)	_____	_____

CUT ALONG DOTTED LINE

CUT ALONG DOTTED LINE

Record Software Versions
MODE — RUN STATUS

SUB-MODE	ITEM	DISPLAY	ITEM EXPANSION
VERS	MBB		CESR131344-__-__-__
	EXV		CESR131172-__-__-__
	EMM		CESR131174-__-__-__
	CP1		CESR131371-__-__-__
	CP2		CESR131371-__-__-__
	CP3		CESR131371-__-__-__
	AUX		CESR131333-__-__-__
	NAVI		CESR131227-__-__-__

(Press and simultaneously to obtain software versions)

Record Configuration Information
MODE — CONFIGURATION

SUB-MODE	ITEM	DISPLAY	ITEM EXPANSION	ENTRY
DISP	TEST	ON/OFF	TEST DISPLAY LED'S	
	METR	ON/OFF	METRIC DISPLAY	
	LANG	x	LANGUAGE SELECTION	
	PAS.E	ENBL/DSBL	PASSWORD ENABLE	
	PASS	xxxx	SERVICE PASSWORD	
UNIT	TYPE	x	UNIT TYPE	
	TONS	xxx	UNIT SIZE	
	CAPA	xxx%	CIRCUIT A% CAPACITY	
	CMP.A	x	NUMBER CIRC A COMPRESSOR	
	CMP.B	x	NUMBER CIRC B COMPRESSOR	
	TCPM	YES/NO	TCPMS INSTALLED?	
	DIS.S	xx.x	DISCHARGE SUPER SETPOINT	
	FAN.S	x	FAN STAGING SELECT	
	CM.A1	xxx AMPS	COMPR. A1 MUST TRIP AMPS	
	CR.A1	xxx AMPS	A1 MUST TRIP AMPS - READ	
	S1.A1	xxx	COMPR.A1 TCPM CONFIG SW1	
	SR.A1	xxx	A1 TCPM CONFIG SW1 READ	
	CM.A2	xxx AMPS	COMPR. A2 MUST TRIP AMPS	
	CR.A2	xxx AMPS	A2 MUST TRIP AMPS - READ	
	S1.A2	xxx	COMPR.A2 TCPM CONFIG SW1	
	SR.A2	xxx	A2 TCPM CONFIG SW1 READ	
	CM.B1	xxx AMPS	COMPR. B1 MUST TRIP AMPS	
	CR.B1	xxx AMPS	B1 MUST TRIP AMPS - READ	
	S1.B1	xxx	COMPR.B1 TCPM CONFIG SW1	
	SR.B1	xxx	B1 TCPM CONFIG SW1 READ	
	CM.B2	xxx AMPS	COMPR. B2 MUST TRIP AMPS	
	CR.B2	xxx AMPS	B2 MUST TRIP AMPS - READ	
	S1.B2	xxx	COMPR.B2 TCPM CONFIG SW1	
SR.B2	xxx	B2 TCPM CONFIG SW1 READ		

CUT ALONG DOTTED LINE

CUT ALONG DOTTED LINE

Record Configuration Information (cont)

MODE — CONFIGURATION (cont)

SUB-MODE	ITEM	DISPLAY	ITEM EXPANSION	ENTRY
OPT1	FLUD	x	COOLER FLUID	
	MLVS	YES/NO	MIN LOAD VALVE SELECT	
	HPCT	x	HEAD PRESSURE CONTROL TYPE	
	VHPT	x	VAR HEAD PRESSURE SELECT	
	PRTS	YES/NO	PRESSURE TRANSDUCERS	
	CPC	ON/OFF	COOLER PUMP CONTROL	
	CNP.I	ON/OFF	CONDENSER PUMP INTERLOCK	
	CNPC	x	CONDENSER PUMP CONTROL	
	CWT.S	YES/NO	CONDENSER FLUID SENSORS	
	EMM	YES/NO	EMM MODULE INSTALLED	
OPT2	CTRL	x	CONTROL METHOD	
	LOAD	x	LOADING SEQUENCE SELECT	
	LLCS	x	LEAD/LAG SEQUENCE SELECT	
	CP.SQ	x	COMPRESSOR SEQUENCE	
	LCWT	xx.x	HIGH LCW ALERT LIMIT	
	DELY	xx	MINUTES OFF TIME	
	CLS.C	ENBL/DSBL	CLOSE CONTROL SELECT	
	ICE.M	ENBL/DSBL	ICE MODE ENABLE	
	C.UNB	xx%	CURRENT UNBALANCE SETPOINT	
	NO.FL	ENBL/DSBL	NO REFRIGERANT FLOW ALRM ENABLE	
	W.MSG	ENBL/DSBL	WINTERIZE ALERT CONFIG	
	ALR.C	x	ALARM RELAY USAGE	
	RSET	CRST	x	COOLING RESET TYPE
CRT1		xxx.x	NO COOL RESET TEMP	
CRT2		xxx.x	FULL COOL RESET TEMP	
DGRC		xx.x	DEGREES COOL RESET	
HRST		x	HEATING RESET TYPE	
HRT1		xxx.x	NO HEAT RESET TEMP	
HRT2		xxx.x	FULL HEAT RESET TEMP	
DGRH		xx.x	DEGREES HEAT RESET	
DMDC		x	DEMAND LIMIT SELECT	
DM20		xxx%	DEMAND LIMIT AT 20 MA	
SHNM		xxx	LOADSHED GROUP NUMBER	
SHDL		xxx%	LOADSHED DEMAND DELTA	
SHTM		xxx	MAXIMUM LOADSHED TIME	
DLS1		xxx%	DEMAND LIMIT SWITCH 1	
DLS2		xxx%	DEMAND LIMIT SWITCH 2	
LLEN		ENBL/DSBL	LEAD/LAG CHILLER ENABLE	
MSSL		SLVE/MAST	MASTER/SLAVE SELECT	
SLVA		xxx	SLAVE ADDRESS	
LLBL		x	LEAD/LAG BALANCE SELECT	
LLBD		xxx	LEAD/LAG BALANCE DELTA	
LLDY		xxx	LAG START DELAY	
PARA		YES/NO	PARALLEL CONFIGURATION	

**Record Configuration Information
MODE — CONFIGURATION (cont)**

SUB-MODE	ITEM	DISPLAY	ITEM EXPANSION	ENTRY
SLCT	CLSP	x	COOLING SETPOINT SELECT	
	HTSP	x	HEATING SETPOINT SELECT	
	RL.S	ENBL/DSBL	RAMP LOAD SELECT	
	CRMP	x.x	COOLING RAMP LOADING	
	HRMP	x.x	HEATING RAMP LOADING	
	HCSW	COOL/HEAT	HEAT COOL SELECT	
	Z.GN	x.x	DEADBAND MULTIPLIER	
	BRN.L	YES/NO	HXC BRINE CONFIG LOCK	
	FP.SP	xxx PSI	OIL FILTER DELTA SETPT	
CCN	CCNA	xxx	CCN ADDRESS	
	CCNB	xxx	CCN BUS NUMBER	
	BAUD	x	CCN BAUD RATE	
SERV	H.PGN	xx.x	HEAD PRESSURE P GAIN	
	H.IGN	xx.x	HEAD PRESSURE I GAIN	
	H.DGN	xx.x	HEAD PRESSURE D GAIN	
	H.MIN	xxx.x	WATER VALVE MINIMUM POS	
	MT.SP	xxx.x	MOTOR TEMP SETPOINT	
	BR.FZ	xxx.x	BRINE FREEZE POINT	
	MC.SP	xxx.x	MAX. COND. TEMP SETPOINT	
	EX.S.A	xx.x	EXVA START POSITION	
	EX.S.B	xx.x	EXVB START POSITION	
	EN.A1	ENBL/DSBL	ENABLE COMPRESSOR A1	
	EN.A2	ENBL/DSBL	ENABLE COMPRESSOR A2	
	EN.B1	ENBL/DSBL	ENABLE COMPRESSOR B1	
	EN.B2	ENBL/DSBL	ENABLE COMPRESSOR B2	
	W.DNE	YES/NO	WINTERIZATION PERFORMED	
	ECON	YES/NO	ECONOMIZED	
	EVPS	x	NUMBER OF EVAP. PASSES	
	LWTC	A/B	CIRCUIT WITH LWT SENSOR	
	AP.SP	xxx.x	APPROACH SETPOINT	
	CND.T	RTPF/MCHX	CND HX TYP: 0 = RTPF 1 = MCHX	
BCST	TD.B.C	ON/OFF	CCN TIME/DATE BROADCAST	
	OAT.B	ON/OFF	CCN OAT BROADCAST	
	GS.B.C	ON/OFF	GLOBAL SCHEDULE BROADCAST	
	BC.AK	ON/OFF	BROADCAST ACKNOWLEDGER	

MODE — SETPOINT

SUB-MODE	ITEM	DISPLAY	ITEM EXPANSION	ENTRY
COOL	CSP.1	xxx.x	COOLING SETPOINT 1	
	CSP.2	xxx.x	COOLING SETPOINT 2	
	CSP.3	xxx.x	ICE SETPOINT	
HEAT	HSP.1	xxx.x	HEATING SETPOINT 1	
	HSP.2	xxx.x	HEATING SETPOINT 2	
HEAD	HD.P.A	xxx.x	HEAD PRESSURE SETPOINT A	
	HD.P.B	xxx.x	HEAD PRESSURE SETPOINT B	

CUT ALONG DOTTED LINE

Component Test — Complete the following tests to make sure all peripheral components are operational before the compressors are started.

MODE – SERVICE TEST

To Enable Service Test Mode, move Enable/Off/Remote Contact Switch to OFF. Configure TEST to ON. Move Switch to ENABLE.

SUB-MODE	ITEM	DISPLAY	ITEM EXPANSION	ENTRY
TEST		ON/OFF	SERVICE TEST MODE	COMPLETE
OUTS	EXV.A	xxx %	EXV % OPEN	
	VH.PA	xxx %	VAR HEAD PRESS %	
	OL.PA	ON/OFF	OIL PUMP	
	MC.A1	ON/OFF	MOTOR COOLING SOLENOID A1	
	MC.A2	ON/OFF	MOTOR COOLING SOLENOID A2	
	OS.A1	ON/OFF	OIL SOLENOID A1	
	OS.A2	ON/OFF	OIL SOLENOID A2	
	EXV.B	xxx %	EXV % OPEN	
	VH.PB	xxx %	VAR HEAD PRESS %	
	OL.PB	ON/OFF	OIL PUMP	
	MC.B1	ON/OFF	MOTOR COOLING SOLENOID B1	
	MC.B2	ON/OFF	MOTOR COOLING SOLENOID B2	
	OS.B1	ON/OFF	OIL SOLENOID B1	
	OS.B2	ON/OFF	OIL SOLENOID B2	
	FAN1	ON/OFF	FAN 1 RELAY	
	FAN2	ON/OFF	FAN 2 RELAY	
	FAN3	ON/OFF	FAN 3 RELAY	
	FAN4	ON/OFF	FAN 4 RELAY	
	CLR.P	ON/OFF	COOLER PUMP RELAY	
	CLR.H	ON/OFF	COOLER HEATER	
CND.P	ON/OFF	CONDENSER PUMP RELAY		
RMT.A	ON/OFF	REMOTE ALARM RELAY		
COMP	CC.A1	ON/OFF	COMPRESSOR A1 RELAY	
	CC.A2	ON/OFF	COMPRESSOR A2 RELAY	
	LD.A1	ON/OFF	LOADER A1 RELAY	
	LD.A2	ON/OFF	LOADER A2 RELAY	
	MLV	ON/OFF	MINIMUM LOAD VALVE	
	OL.H.A	ON/OFF	OIL HEATER	
	CC.B1	ON/OFF	COMPRESSOR B1 RELAY	
	CC.B2	ON/OFF	COMPRESSOR B2 RELAY	
	LD.B1	ON/OFF	LOADER B1 RELAY	
	LD.B2	ON/OFF	LOADER B2 RELAY	
OL.H.B	ON/OFF	OIL HEATER		

CUT ALONG DOTTED LINE

CUT ALONG DOTTED LINE