



Installation Instructions

CONTENTS

	Page
SAFETY CONSIDERATIONS	1
GENERAL	1-3
INSTALLATION	4-43
Location	4
Unit Mounting Requirements	21
Step 1 — Inspect Shipment	23
Step 2 — Position the Unit	23
Step 3 — Place the Unit	23
Step 4 — Check Compressor Mounting	23
Step 5 — Make Piping Connections	24
• UNITS WITHOUT MANIFOLD	
• 30MPA SYSTEM CONDENSER	
• 30MPW UNITS WITH NITROGEN CHARGE	
• EVACUATION AND DEHYDRATION	
• 30MPW CONDENSER DESCRIPTION	
• 30MPW CONDENSER	
• CONDENSER WATER CONTROL VALVE	
• EVAPORATOR DESCRIPTION	
• EVAPORATOR PIPING	
• FOR UNITS WITH WATER MANIFOLD	
• DUAL CHILLER CONTROL OPTION	
• MULTI - UNIT CHILLER CONTROLLER ACCESSORY	
• AIR SEPARATION	
Step 6 — Fill the Chilled Water Loop	37
• WATER SYSTEM CLEANING	
• FILLING THE SYSTEM	
Step 7 — Make Electrical Connections	38
• 30MPA, MPW CONTROL BOX	
• 30MPE DISTRIBUTION PANEL	
• UNBALANCED 3-PHASE SUPPLY VOLTAGE	

SAFETY CONSIDERATIONS

Installing, starting up, and servicing this equipment (Fig. 1-4) can be hazardous due to system pressures, electrical components, and equipment location (roofs, elevated structures, etc.).

Only trained, qualified installers and service technicians should install, start up, and service this equipment.

When working on the equipment, observe precautions in the literature and on tags, stickers, and labels attached to the equipment.

- Follow all safety codes.
- Wear safety glasses and work gloves.
- Use care in handling, rigging, and setting bulky equipment.

⚠ WARNING

DO NOT USE TORCH to remove any component. System contains oil and refrigerant under pressure.

To remove a component, wear protective gloves and goggles and proceed as follows:

- a. Shut off electrical power to unit.
- b. Recover refrigerant to relieve all pressure from system using both high-pressure and low pressure ports.
- c. Traces of vapor should be displaced with nitrogen and the work area should be well ventilated. Refrigerant in contact with an open flame produces toxic gases.
- d. Cut component connection tubing with tubing cutter and remove component from unit. Use a pan to catch any oil that may come out of the lines and as a gage for how much oil to add to the system.
- e. Carefully unsweat remaining tubing stubs when necessary. Oil can ignite when exposed to torch flame.

Failure to follow these procedures may result in personal injury or death.

⚠ WARNING

Electrical shock can cause personal injury and death. Shut off all power to this equipment during installation. There may be more than one disconnect switch. Tag all disconnect locations to alert others not to restore power until work is completed.

⚠ CAUTION

DO NOT re-use compressor oil or any oil that has been exposed to the atmosphere. Dispose of oil per local codes and regulations. DO NOT leave refrigerant system open to air any longer than the actual time required to service the equipment. Seal circuits being serviced and charge with dry nitrogen to prevent oil contamination when timely repairs cannot be completed. Failure to follow these procedures may result in damage to equipment.

GENERAL

These installation instructions cover the 30MPA, MPW units with *ComfortLink* controls. The 30MPA units are condenserless units and the 30MPW units are fluid cooled. See Fig. 1-4 for different unit configurations. See Fig. 5 for model number nomenclature and Fig. 6-19 for unit dimensional details and corner weights.

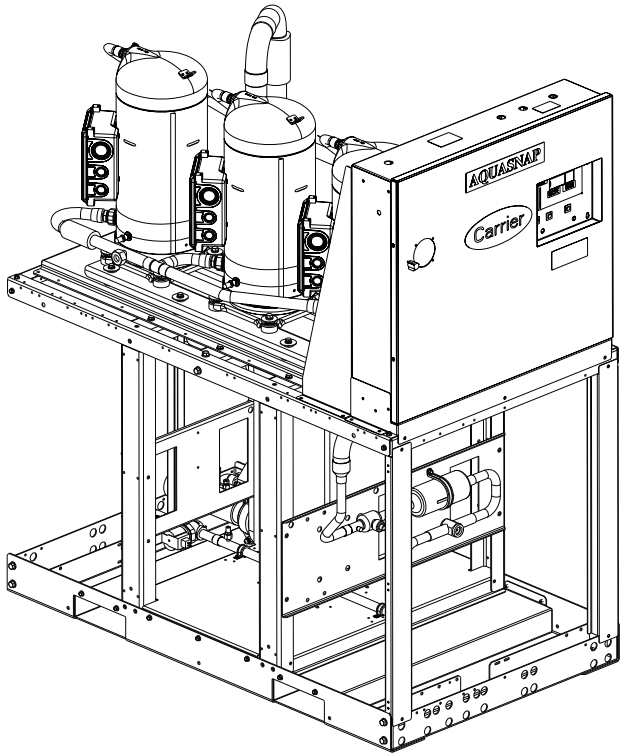

Fig. 1 — 30MPA Unit (Size 020-045)

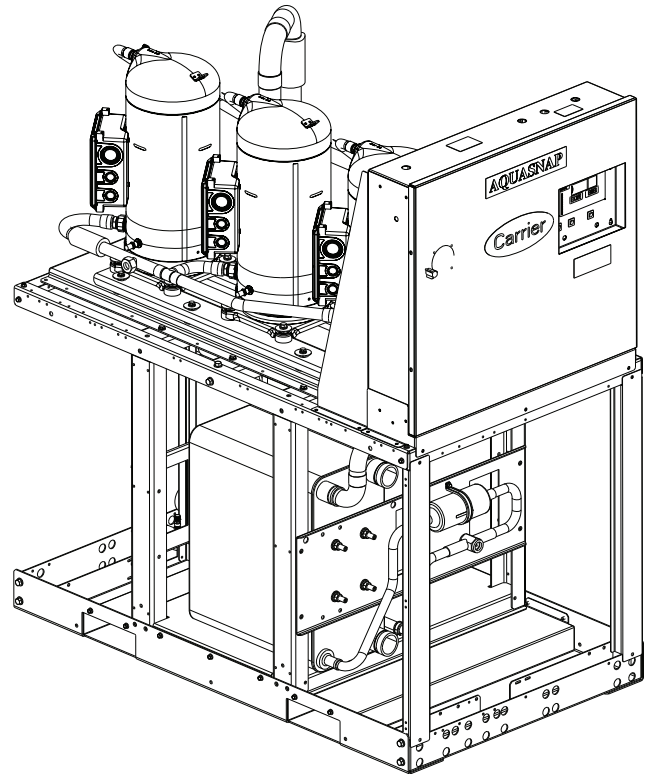

Fig. 3 — 30MPW Unit (Size 016-045)

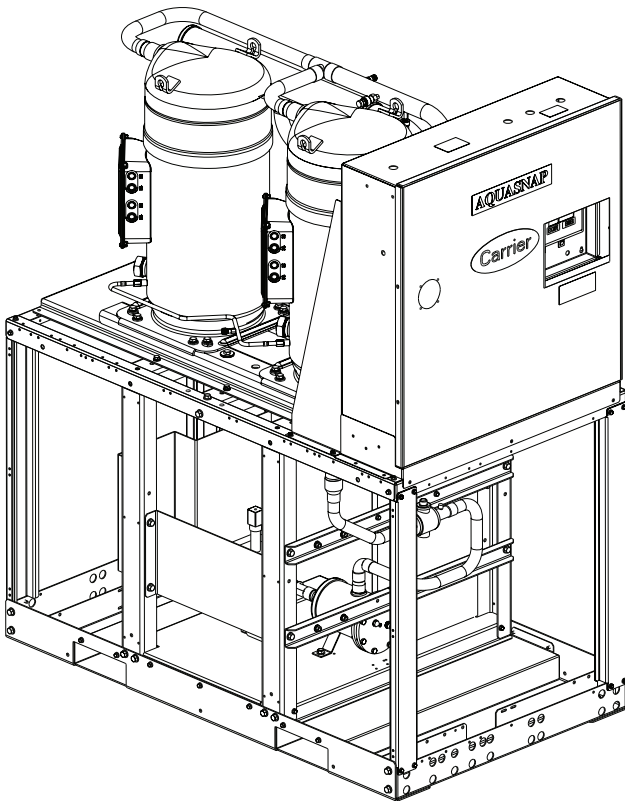

Fig. 2 — 30MPA Unit (Size 050-071)

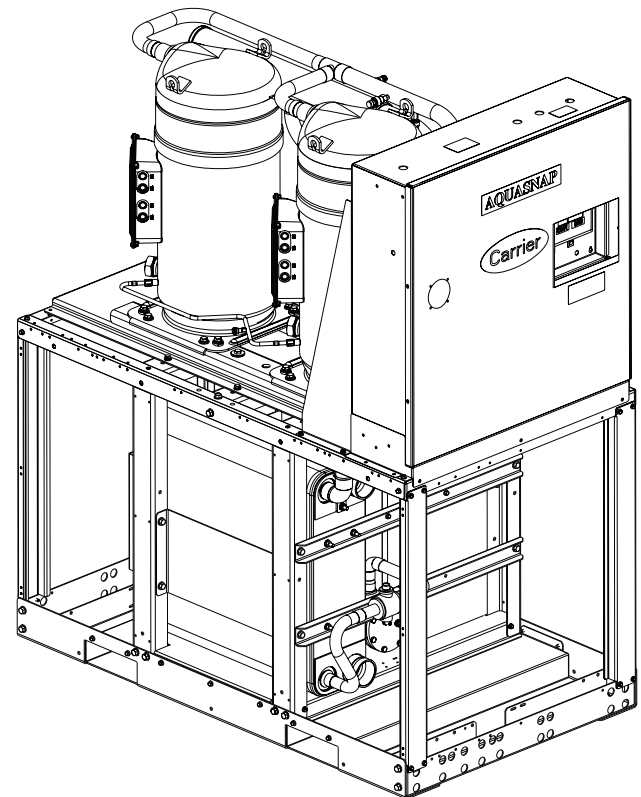

Fig. 4 — 30MPW Unit (Size 050-071)

30MP A 030 6 0 - 0 0 0 0 5

30MP – AquaSnap® Liquid Chiller with *ComfortLink* Controls

Condenser Option

- A – Chiller without Condenser (Air-Cooled)
- W – Chiller with Condenser (Water-Cooled)

Unit Size – Nominal Tons (kW)

- 016– 15 (53)** 050 – 50 (176)
- 020 – 20 (70) 055 – 55 (194)
- 030 – 30 (106) 060 – 60 (211)
- 032 – 30 (106)** 065 – 65 (229)
- 040 – 40 (141) 071 – 71 (250)
- 045 – 45 (158)

Voltage Options

- 1 – 575-3-60
- 2 – 380-3-60
- 5 – 208/230-3-60
- 6 – 460-3-60
- 9 – 380/415-3-50

Sound/Mounting Options

- 0 – None
- 1 – Sound Enclosure Panels
- 2 – Water Manifold Sound Enclosure Panels
- 3 – Height Adjustment Kit
- 4 – Height Adjustment Kit, Sound Enclosure Panels
- 5 – Height Adjustment Kit, Water Manifold Sound Enclosure Panels
- 9 – Mobility Kit (Wheels)
- B – Mobility Kit (Wheels), Sound Enclosure Panels
- D – Height Adjustment Kit, Mobility Kit (Wheels)
- F – Height Adjustment Kit, Mobility Kit (Wheels), Sound Enclosure Panels
- G – Height Adjustment Kit, Mobility Kit (Wheels), Water Manifold Sound Enclosure Panels
- L – Compressor Sound Blankets
- M – Compressor Sound Blankets, Mobility Kit (Wheels)
- N – Compressor Sound Blankets, Height Adjustment Kit
- P – Compressor Sound Blankets, Mobility Kit (Wheels), Height Adjustment Kit

Design Revision Level

- – Initial Release

Packaging Options

- 5 – Bag, No Compressor Insulation (Std)
- 7 – Bag, Compressor Insulation
- B – Export Crating, No Compressor Insulation
- D – Export Crating, Compressor Insulation

Controls/Interface Options

- 0 – Scrolling Marquee Display (Std)
- 1 – Scrolling Marquee Display with BACnet Communication Option
- 5 – Scrolling Marquee Display, EMM
- 6 – Scrolling Marquee Display with BACnet Communication Option and EMM

Disconnect Options

- 0 – Standard (Terminal Block)
- 1 – Non-Fused Disconnect Switch
- 2 – Fused Disconnect Switch (selected models)††

Capacity Control/High Interrupt Options

- 0 – Standard
- 1 – Hot Gas Bypass
- 2 – Digital Compressor*
- 3 – High Interrupt
- 4 – High Interrupt and Hot Gas Bypass
- 5 – High Interrupt and Digital Compressor
- 6 – High Condensing†
- 7 – High Condensing† and Hot Gas Bypass
- 8 – High Interrupt and High Condensing†
- 9 – High Interrupt, High Condensing†, and Hot Gas Bypass

Water Manifold/Brine Options

- 0 – Comfort Cooling Duty (32°-60°F) (0.0°-16.5°C) (Std)
- 1 – Water Manifold Piping (Includes Combination Valve)
- 2 – Water Manifold Piping and Evaporator Isolation (Includes Combination Valve)
- 3 – Water Manifold Piping and Head Pressure Control (Includes Combination Valve)
- 4 – Water Manifold Piping, Evaporator Isolation and Head Pressure Control (Includes Combination Valve)
- 5 – Water Manifold Piping and Evaporator Isolation (Includes Combination Valve) Medium Temperature Brine
- 6 – Water Manifold Piping and Head Pressure Control (Includes Combination Valve) Medium Temperature Brine
- 7 – Medium Temperature Brine (15°-32°F) (-9.4°-0.0°C)
- 8 – Water Manifold Piping (Includes Combination Valve), Medium Temperature Brine
- 9 – Water Manifold Piping, Evaporator Isolation and Head Pressure Control (Includes Combination Valve), Medium Temperature Brine
- B – Nitrogen Charge
- C – Water Manifold Piping (Includes Combination Valve), Nitrogen Charge
- D – Water Manifold Piping and Evaporator Isolation (Includes Combination Valve), Nitrogen Charge
- F – Water Manifold Piping and Head Pressure Control (Includes Combination Valve), Nitrogen Charge
- H – Medium Temperature Brine, Nitrogen Charge
- J – Water Manifold Piping and Evaporator Isolation (Includes Combination Valve), Medium Temperature Brine, Nitrogen Charge
- K – Water Manifold Piping and Head Pressure Control (Includes Combination Valve), Medium Temperature Brine, Nitrogen Charge
- L – Water Manifold Piping, Evaporator Isolation and Head Pressure Control (Includes Combination Valve), Medium Temperature Brine, Nitrogen Charge

LEGEND

EMM — Energy Management Module

- * Digital compressor available on models 016-045 only.
- † High condensing options available on models 050-071 only. High condensing option is standard on models 020, 030, 040, 045, High condensing option is not available on models 016 and 032.
- ** 016 and 032 are only available in 30MPW configurations. 30MPA configurations are not available for 016 and 032 units.
- †† Fused Disconnect is required for 016 and 032 units equipped with the High Interrupt Option. Fused Disconnect is NOT available for any other units.

→ Fig. 5 — 30MP Model Number Nomenclature

INSTALLATION

⚠ WARNING

If a 30MPE electrical distribution panel is purchased, it is crucial that each individual 30MP chiller be placed in the appropriate position relative to its corresponding 30MPE electrical distribution panel. Failure to do so could cause personal injury or death. Please consult the 30MPE Electrical Distribution Panel Installation Instructions for more details.

Location — Do not store units in an area exposed to weather because of sensitive control mechanisms and electronic devices. Locate unit indoors.

When considering location, consult National Electrical Code (NEC) and local code requirements. Allow sufficient space for wiring, piping, and service. Install the unit in an area where it will not be exposed to ambient temperatures below 50°F (10°C).

Allow 36 in. (914 mm) in front of the unit for the control box access door. Additional clearance may be required per local codes. Prior to installation determine which direction the compressor will be removed, and leave 3 to 4 ft (914 to 1219 mm) clearance for removal.

On all units leave 3 ft (0.9 m) of clearance opposite the control box end to make water/brine connections to the evaporator, accessing the TXV (thermostatic expansion valve) or EXV (electronic expansion valve), fluid thermistors, and proof of flow switch.

For units without water manifold option, leave 2 ft (610 mm) on the left facing control box side for making

refrigeration connections (30MPA) or leave 2 ft (610 mm) on one side for making fluid connections (30MPW) to condenser. See Fig. 6-17.

The floor must be strong enough to support the unit operating weight (see Tables 1-4, Fig. 6-14, and Fig. 18). If necessary, add a supporting structure (steel beams or reinforced concrete slabs) to the floor to transfer weight to the nearest beams.

Additional weight of factory-installed sound enclosure option is 75 lb (34 kg). Additional operating weight of 30MPA water manifold option is 218 lb (99 kg). Additional operating weight of 30MPW water manifold option is 436 lb (198 kg).

⚠ CAUTION

Be sure interconnecting piping and electrical conduits are suspended freely, and are not in contact with any adjacent walls. Be sure unit capillaries are not rubbing against anything. Damage to the unit or walls may result.

Multiple chiller applications using the Vibration Isolator Springs Accessory Kit should be set on a mounting frame, which should then be installed on the isolator springs. I-beam or square metal tubing are acceptable materials for the mounting frame. Each chiller **MUST** be supported in the center (under the heat exchangers) by the mounting frame, however isolators are only necessary at the four corners of each unit. Use Fig. 18, for the corner weights of each when supported in four locations.

For standalone units (chillers which are not connected via common water piping), 30MP 015-045 must be supported at the four corner locations shown in Fig. 18. 30MP 050-071 must be supported at the six locations shown in Fig. 19.

UNIT	OPERATING WEIGHT (lb)						DIMENSIONS (in.)					
	STANDARD UNIT						A	B	C	D	E	F
30MPA050	1398 (634 kg)	14.10 (358.1 mm)	27.38 (695.4 mm)	37.56 (954.0 mm)								
30MPA055	1413 (641 kg)	14.06 (357.1 mm)	27.39 (695.7 mm)	37.62 (955.5 mm)								
30MPA060	1437 (652 kg)	14.26 (362.2 mm)	27.37 (695.2 mm)	37.36 (948.9 mm)	6.43 (163.4 mm)	8.45 (214.6 mm)	20.43 (519.0 mm)					
30MPA065	1468 (666 kg)	14.17 (359.9 mm)	27.39 (695.7 mm)	37.48 (952.0 mm)								
30MPA071	1506 (683 kg)	14.31 (363.4 mm)	27.30 (693.4 mm)	38.08 (967.2 mm)								

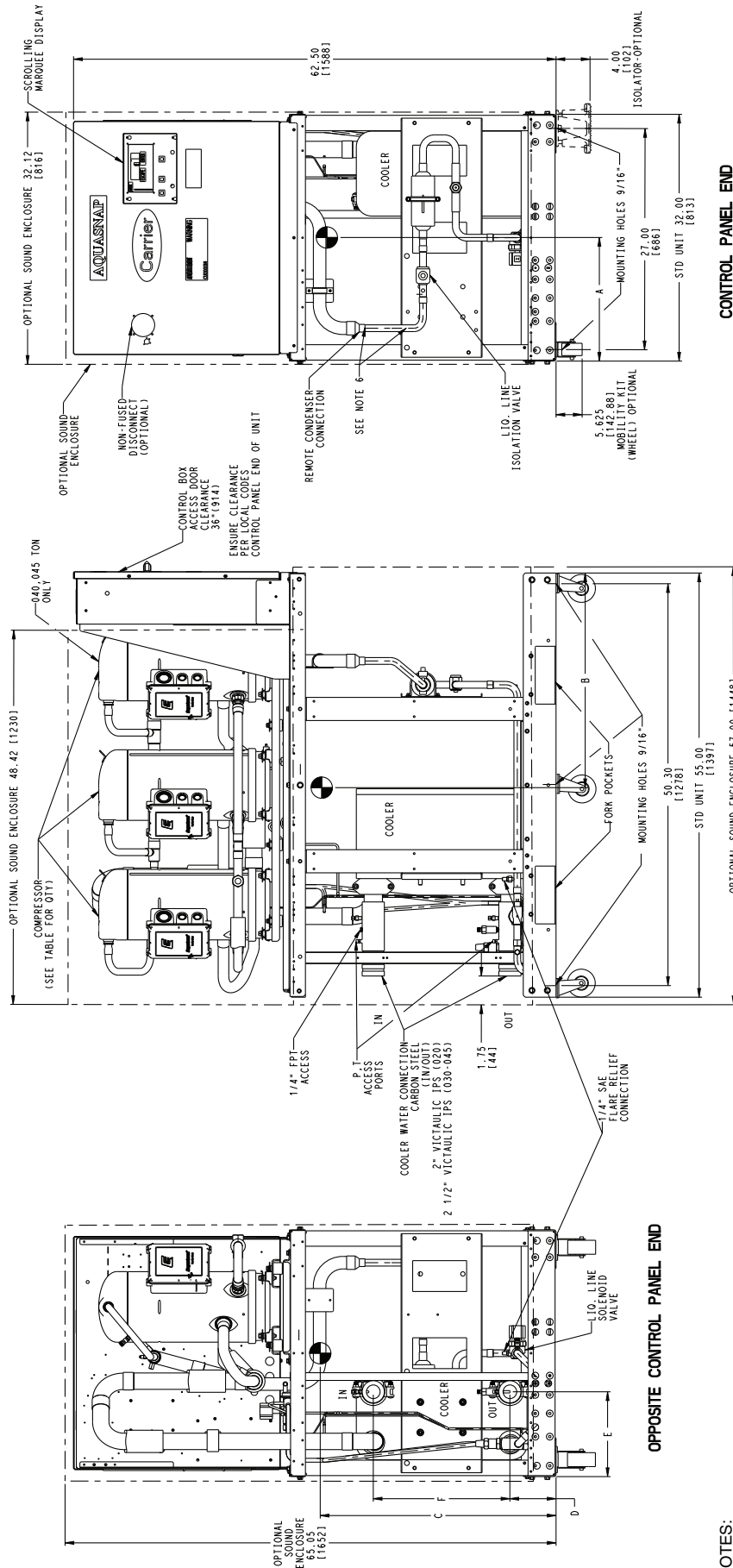

- NOTES:
1. Operating weight includes weight of water and refrigerant.
 2. Ⓞ Denotes center of gravity.
 3. Dimensions are shown in [] are in millimeters.
 4. Allow 36-in. (914 mm) clearance on control panel end, opposite control panel end and above the unit. All clearances must be in accordance with local codes.
 5. --- Denotes accessory or factory-installed option.
 6. Unit shipped with nitrogen holding charge. Field removal of tube and reducing coupling is required. Consult Installation Instructions for discharge and liquid pipe connection sizes.

Fig. 6 — Dimensions — 30MPA 020-045 (Air-Cooled Chillers) Standard Unit

UNIT	OPERATING WEIGHT (lb)		DIMENSIONS (in.)						NUMBER OF COMPRESSORS
	STANDARD UNIT	UNIT	A	B	C	D	E	F	
30MPA050	1398 (634 kg)		14.10 (358.1 mm)	27.38 (695.4 mm)	37.56 (954.0 mm)				
30MPA055	1413 (641 kg)		14.06 (357.1 mm)	27.39 (695.7 mm)	37.62 (955.5 mm)				
30MPA060	1437 (652 kg)		14.26 (362.2 mm)	27.37 (695.2 mm)	37.36 (948.9 mm)	6.43 (163.4 mm)	8.45 (214.6 mm)	20.43 (519.0 mm)	2
30MPA065	1468 (666 kg)		14.17 (359.9 mm)	27.39 (695.7 mm)	37.48 (952.0 mm)				
30MPA071	1506 (683 kg)		14.31 (363.4 mm)	27.30 (693.4 mm)	38.08 (967.2 mm)				

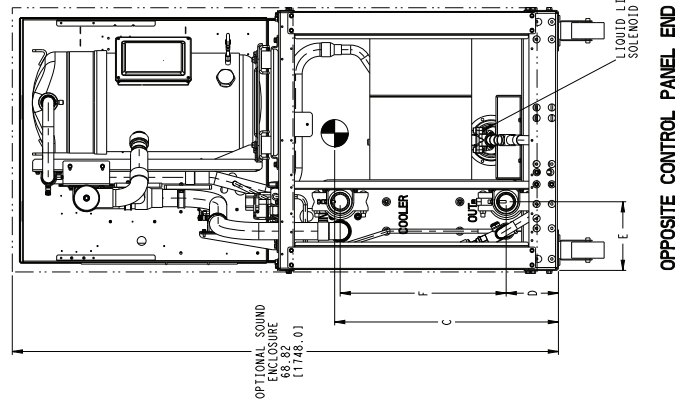

OPPOSITE CONTROL PANEL END

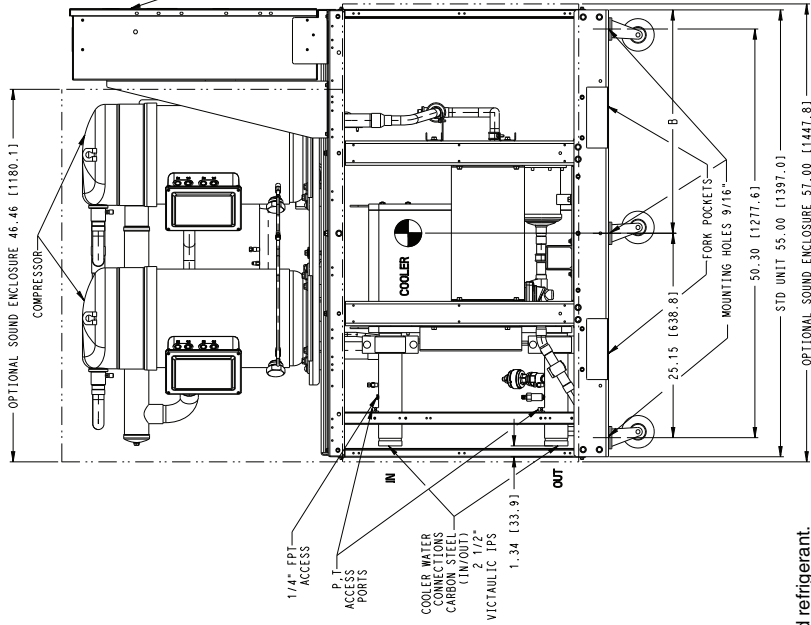

CONTROL PANEL END

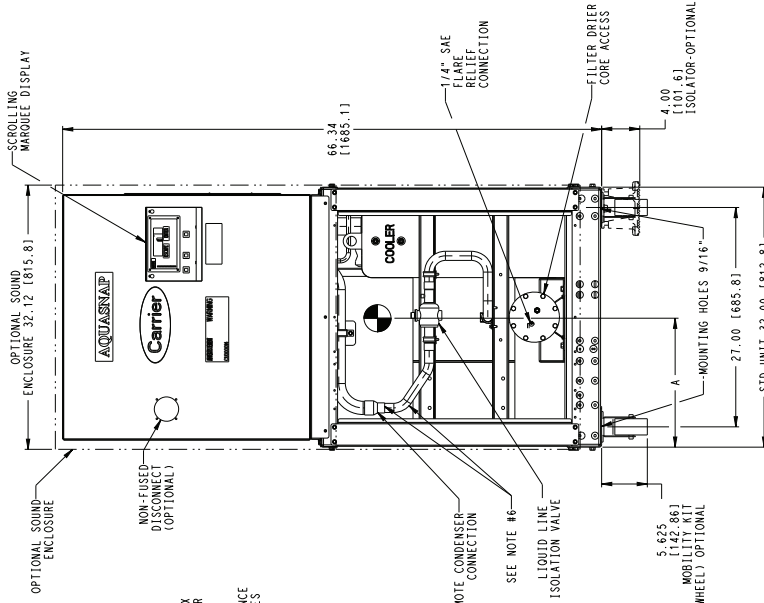
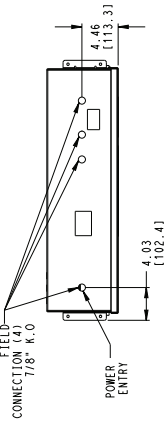

CONTROL PANEL END

- NOTES:**
- Operating weight includes weight of water and refrigerant.
 - Denotes center of gravity.
 - Dimensions are shown in inches. Dimensions in [] are in millimeters.
 - Allow 36-in. (914 mm) clearance on control panel end, opposite control panel end and above the unit. All clearances must be in accordance with local codes.
 - Denotes accessory or factory-installed option.
 - Unit shipped with nitrogen holding charge. Field removal of tube and reducing coupling is required. Consult installation instructions for discharge and liquid pipe connection sizes.

Fig. 7 — Dimensions — 30MPA 050-071 (Air-Cooled Chillers) Standard Unit (Non-Manifold Units)

UNIT	OPERATING WEIGHT (lb) MANIFOLD UNIT	DIMENSIONS (in.)			NUMBER OF COMPRESSORS
		A	B	C	
30MP A020	920 (418 kg)	14.03 (356 mm)	39.01 (991 mm)	41.09 (1044 mm)	2
30MP A030	973 (442 kg)	14.47 (368 mm)	38.29 (973 mm)	39.90 (1014)	
30MP A040	4416 (521 kg)	13.89 (353 mm)	36.58 (929 mm)	39.72 (1009 mm)	3
30MP A045	1196 (544 kg)	14.31 (363 mm)	36.21 (920 mm)	38.91 (988 mm)	

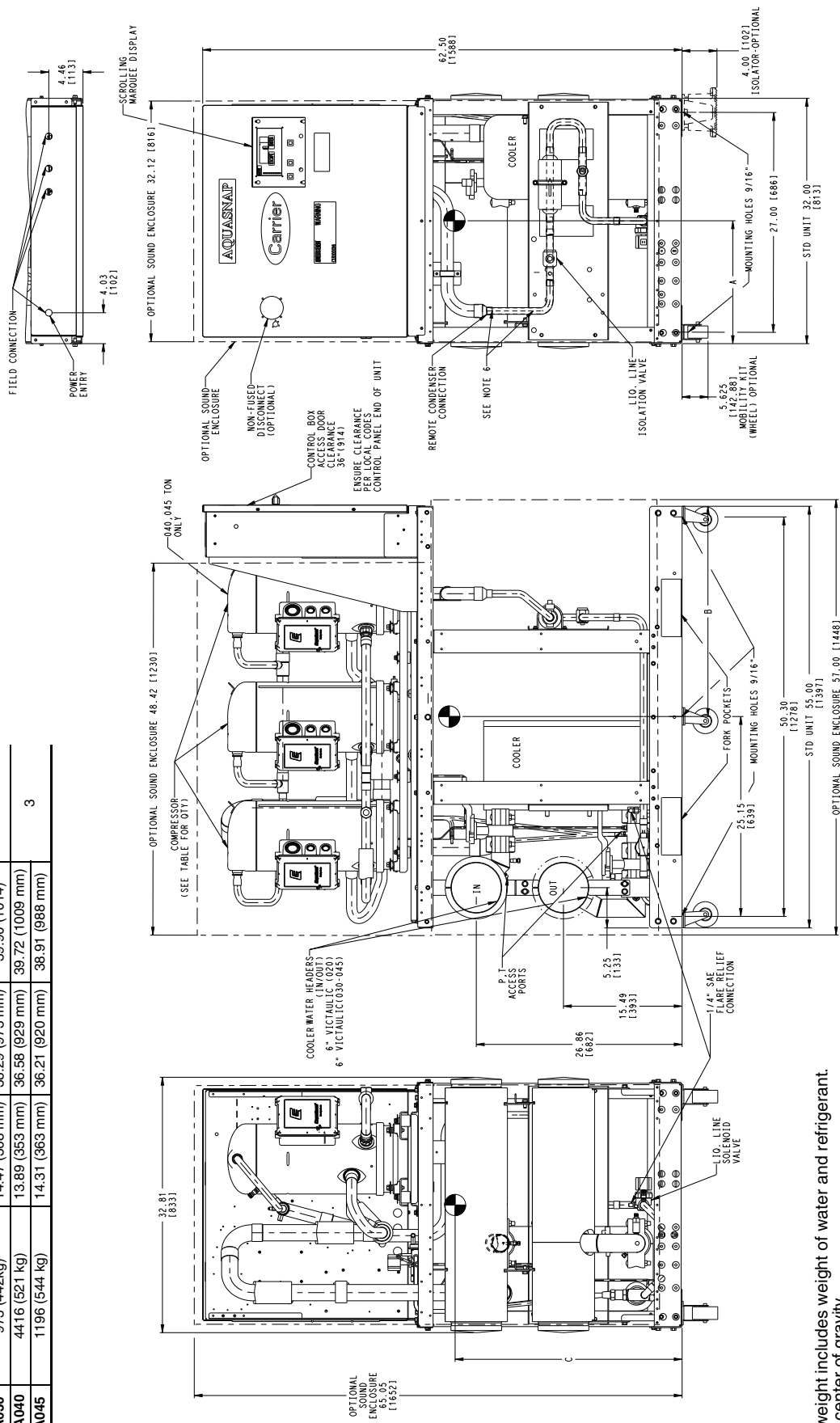

- NOTES:
1. Operating weight includes weight of water and refrigerant.
 2. Ⓢ Denotes center of gravity.
 3. Dimensions are shown in inches. Dimensions in [] are in millimeters.
 4. Allow 36-in. (914 mm) clearance on control panel end, opposite control panel end and above the unit. All clearances must be in accordance with local codes.
 5. --- Denotes accessory or factory-installed option.
 6. Unit shipped with nitrogen holding charge. Field removal of tube and reducing coupling is required. Consult Installation Instructions for discharge and liquid pipe connection sizes.

Fig. 8 — Dimensions — 30MPA 020-045 Manifold Unit (Air-Cooled Chillers)

UNIT	OPERATING WEIGHT (lb)	DIMENSIONS (in.)					
		A	B	C	D	E	F
30MPA050	1616 (733 kg)	14.36 (364.7 mm)	30.21 (767.3 mm)	34.36 (872.7 mm)			
30MPA055	1631 (740 kg)	14.32 (363.7 mm)	30.19 (766.8 mm)	34.44 (874.8 mm)			
30MPA060	1655 (750 kg)	14.49 (368.0 mm)	30.14 (765.5 mm)	34.26 (870.2 mm)	6.43 (163.4 mm)	8.45 (214.6 mm)	20.43 (519.0 mm)
30MPA065	1686 (765 kg)	14.41 (366.0 mm)	30.10 (764.5 mm)	34.42 (874.2 mm)			
30MPA071	1724 (782 kg)	14.52 (368.8 mm)	29.96 (760.9 mm)	35.01 (889.2 mm)			

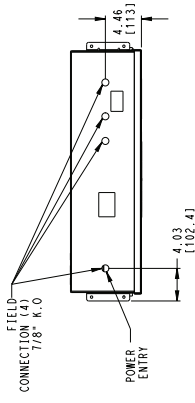
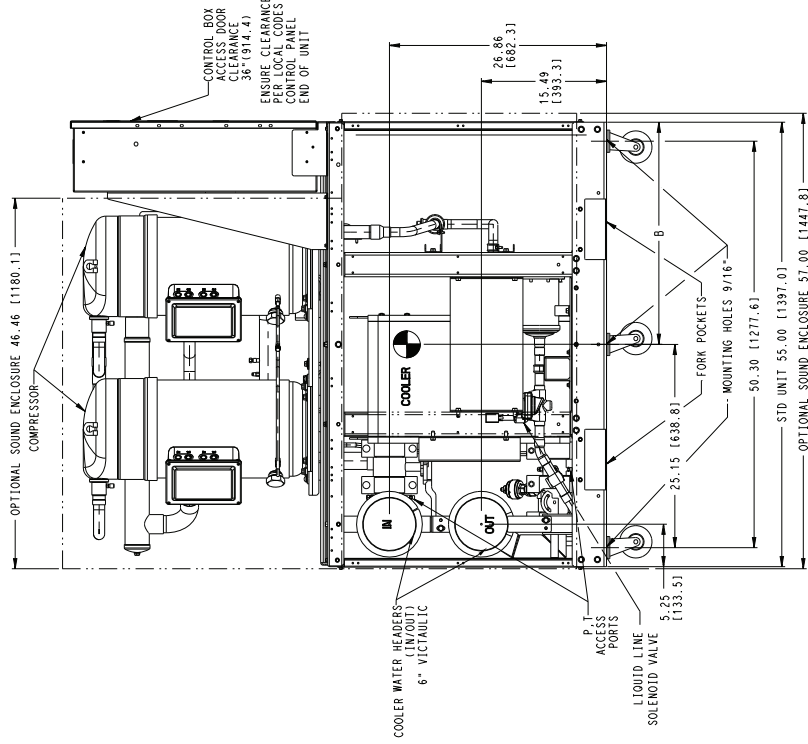
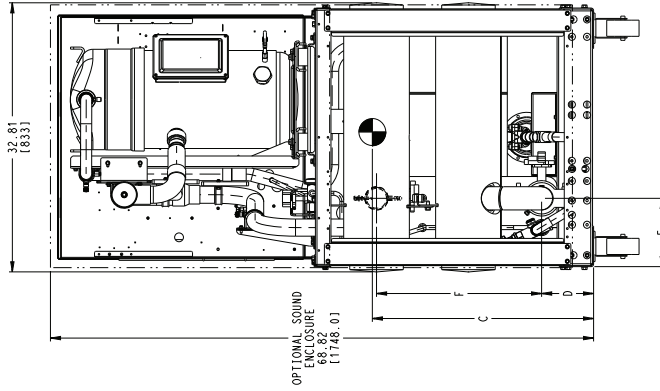

- NOTES:
1. Operating weight includes weight of water and refrigerant.
 2. \odot Denotes center of gravity.
 3. Dimensions in () are in millimeters, and weights in () are in kilograms.
 4. Allow 36-in. (914.4 mm) clearance on control panel end, opposite control panel end, and above the unit. All clearances must be in accordance with local codes.
 5. --- Denotes accessory or factory-installed option.
 6. Unit shipped with nitrogen holding charge. Field removal of tube and reducing coupling is required. Consult Installation Instructions for discharge and liquid pipe connection sizes.

Fig. 9 — Dimensions — 30MPA 050-071 Manifold Unit (Air-Cooled Chillers)

UNIT	OPERATING WEIGHT (lb)	DIMENSIONS (in.)										NUMBER OF COMPRESSORS
		A	B	C	D	E	F	G	H	J		
30MPW016	671 (305 kg)	12.71 (323 mm)	18.80 (477 mm)	36.62 (930 mm)	5.54 (141 mm)	6.44 (164 mm)	18.50 (470 mm)	5.54 (141 mm)	6.44 (164 mm)	18.50 (470 mm)	18.50 (470 mm)	2
30MPW020	790 (359 kg)	12.32 (313 mm)	19.83 (504 mm)	36.61 (930 mm)	5.85 (149 mm)	11.09 (282 mm)	17.95 (456 mm)	5.87 (149 mm)	11.12 (282 mm)	17.95 (456 mm)	17.95 (456 mm)	2
30MPW030	992 (451 kg)	11.79 (300 mm)	20.74 (527 mm)	33.08 (840 mm)	5.85 (149 mm)	11.09 (282 mm)	17.95 (456 mm)	5.87 (149 mm)	11.12 (282 mm)	17.95 (456 mm)	17.95 (456 mm)	2
30MPW032	See separate sheet											3
30MPW040	1214 (552 kg)	11.30 (287 mm)	21.50 (546 mm)	33.13 (841 mm)	5.85 (149 mm)	11.09 (282 mm)	17.95 (456 mm)	5.99 (152 mm)	11.00 (279 mm)	17.72 (450 mm)	17.72 (450 mm)	3
30MPW045	1298 (590 kg)	11.61 (295 mm)	21.70 (551 mm)	32.30 (818 mm)	5.85 (149 mm)	11.09 (282 mm)	17.95 (456 mm)	5.99 (152 mm)	11.00 (279 mm)	17.72 (450 mm)	17.72 (450 mm)	3

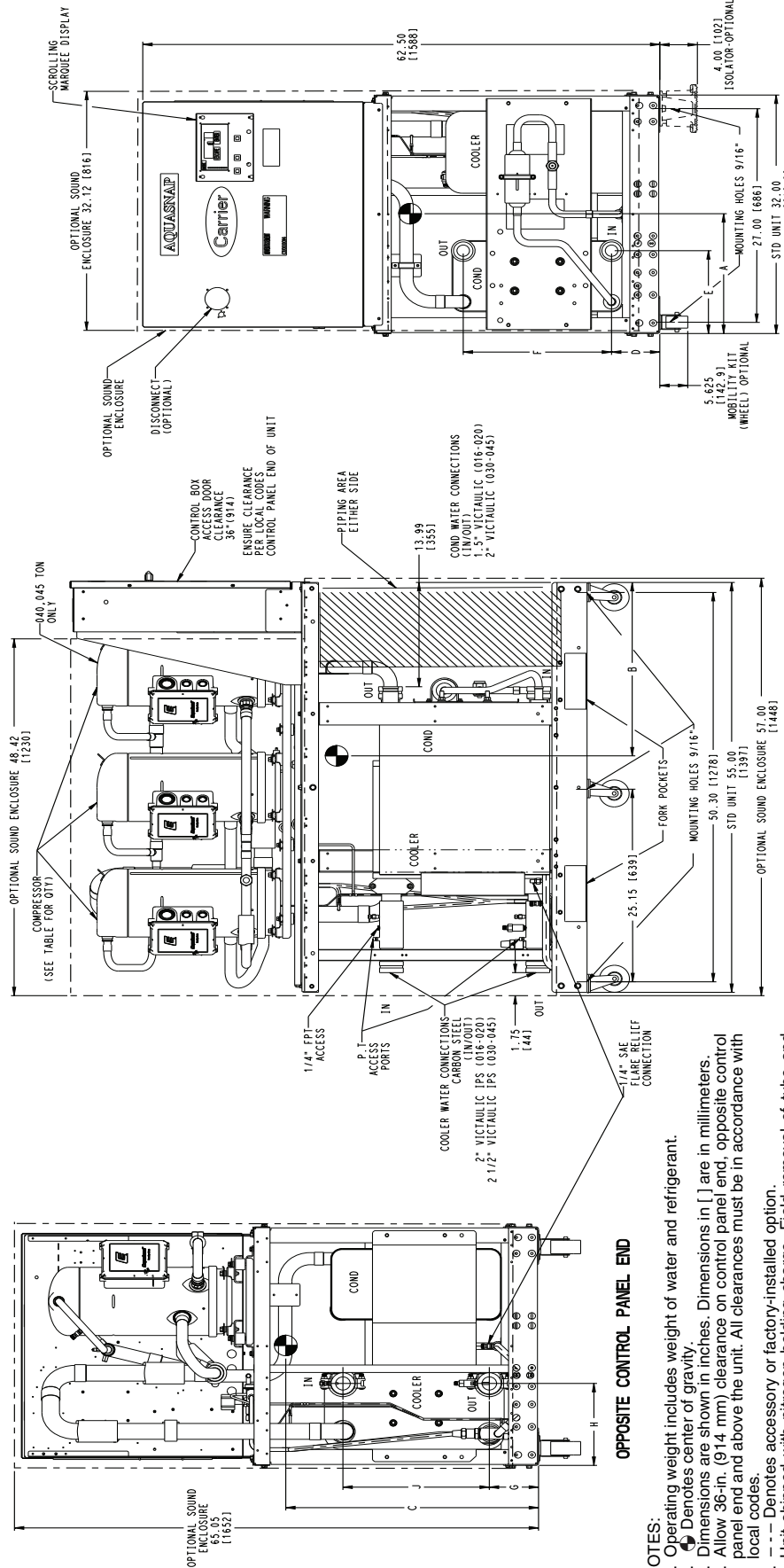
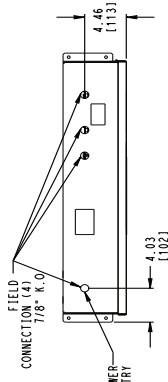

OPPOSITE CONTROL PANEL END

- NOTES:
- Operating weight includes weight of water and refrigerant.
 - Denotes center of gravity.
 - Dimensions are shown in inches. Dimensions in [] are in millimeters.
 - Allow 36-in. (914 mm) clearance on control panel end, opposite control panel end and above the unit. All clearances must be in accordance with local codes.
 - Denotes accessory or factory-installed option.
 - Unit shipped with nitrogen holding charge. Field removal of tube and reducing coupling is required. Consult installation instructions for discharge and liquid pipe connection sizes.

Fig. 10 — Dimensions — 30MPW 016-045 (Liquid-Cooled Chillers) Standard Unit Except 30MP032

CONTROL PANEL END

UNIT	DIMENSIONS (in.)									
	A	B	C	D	E	F	G	H	J	
30MPW050	12.65 (321.3 mm)	27.33 (694.2 mm)	35.58 (903.7 mm)							
30MPW055	12.61 (320.3 mm)	27.34 (694.4 mm)	35.65 (905.5 mm)							
30MPW060	12.65 (321.3)	27.76 (705.1 mm)	35.13 (892.3 mm)	6.43 (163.4 mm)	8.45 (214.6 mm)	20.43 (519.0 mm)	6.43 (163.4 mm)	8.45 (214.6 mm)	20.43 (519.0 mm)	
30MPW065	12.58 (319.5)	27.76 (705.1 mm)	35.27 (895.5 mm)							
30MPW071	12.79 (324.9)	27.67 (702.9 mm)	35.02 (889.5 mm)							

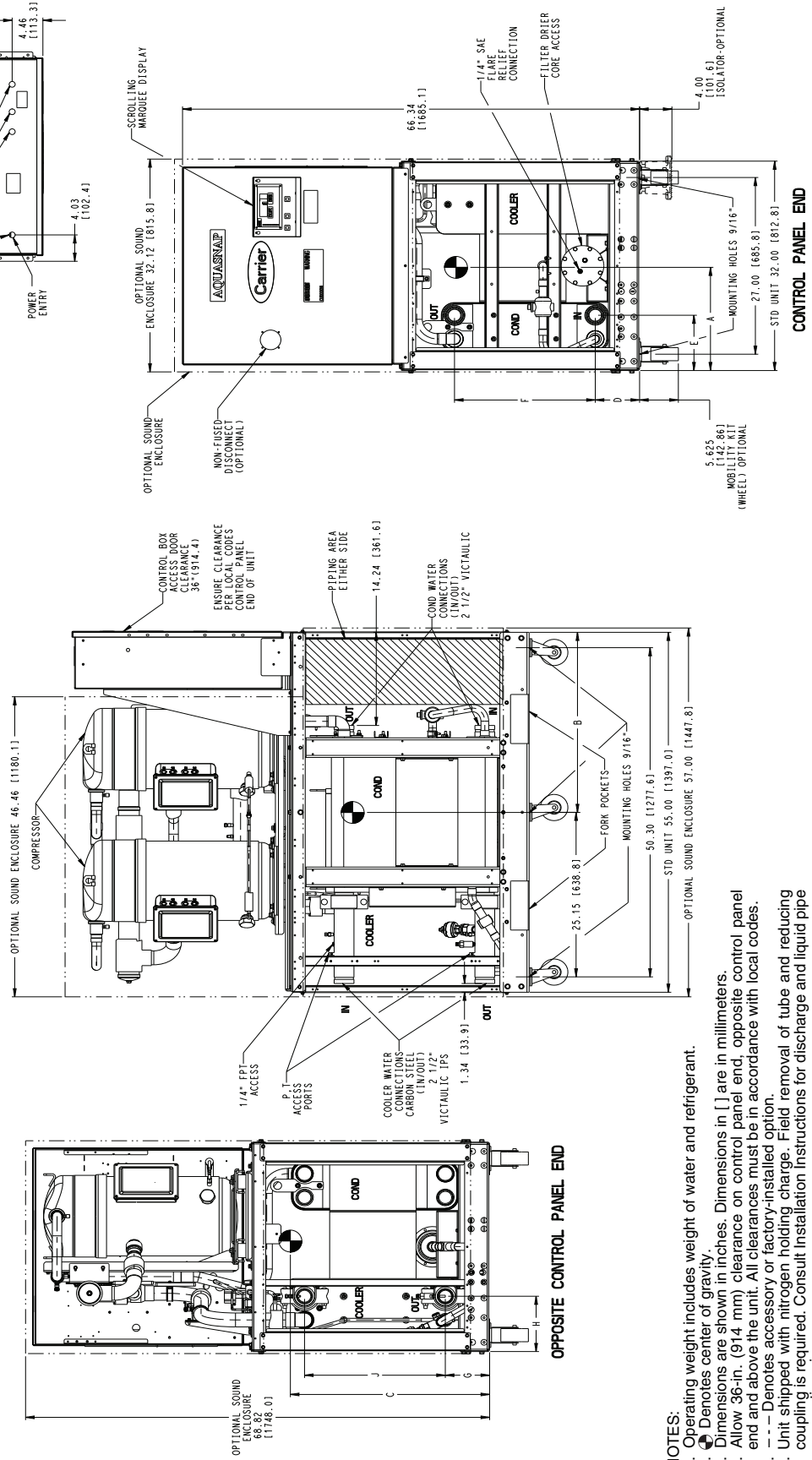

- NOTES:
- Operating weight includes weight of water and refrigerant.
 - Denotes center of gravity.
 - Dimensions are shown in inches. Dimensions in [] are in millimeters.
 - Allow 36-in. (914 mm) clearance on control panel end, opposite control panel end and above the unit. All clearances must be in accordance with local codes.
 - Denotes accessory or factory-installed option.
 - Unit shipped with nitrogen holding charge. Field removal of tube and reducing coupling is required. Consult installation instructions for discharge and liquid pipe connection sizes.

Fig. 12 — Dimensions — 30MPW 050-071 (Liquid-Cooled Chillers) Standard Unit

UNIT	OPERATING WEIGHT (lb)			DIMENSIONS (in.)		
	MANIFOLD UNIT			A	B	C
30MPW032	1404 (638 kg)	13.08 (332 mm)	30.46 (774 mm)	32.93 (837 mm)		

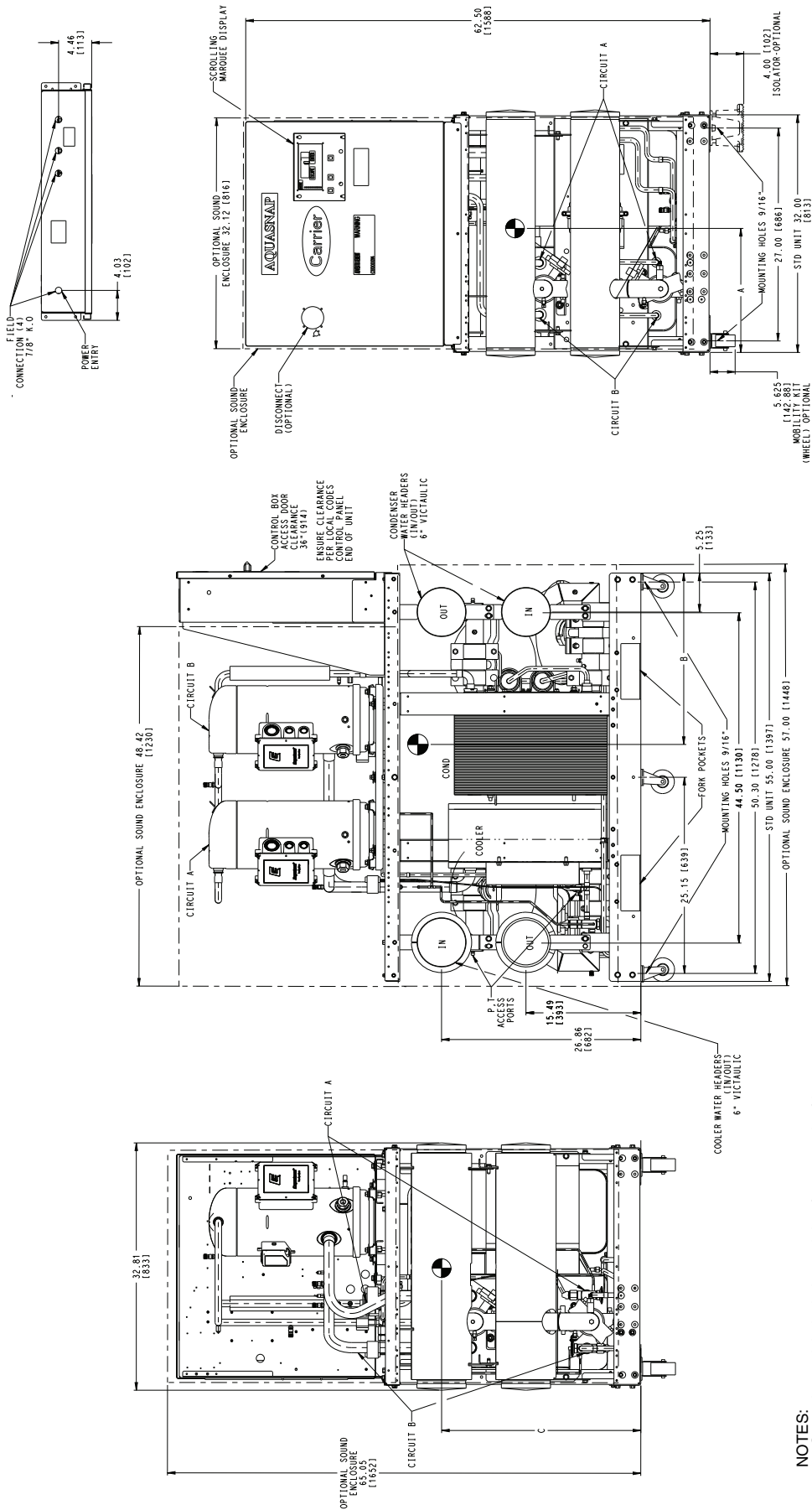

- NOTES:**
1. Operating weight includes weight of water and refrigerant.
 2. Ⓢ Denotes center of gravity.
 3. Dimensions are shown in inches. Dimensions in [] are in millimeters.
 4. Allow 36-in. (914 mm) clearance on control panel end, opposite control panel end and above the unit. All clearances must be in accordance with local codes.
 5. --- Denotes accessory or factory-installed option.
 6. Unit shipped with nitrogen holding charge. Field removal of tube and reducing coupling is required. Consult installation instructions for discharge and liquid pipe connection sizes.

Fig. 14 — Dimensions — 30MPW 032 (Liquid-Cooled Chillers) Manifold Unit

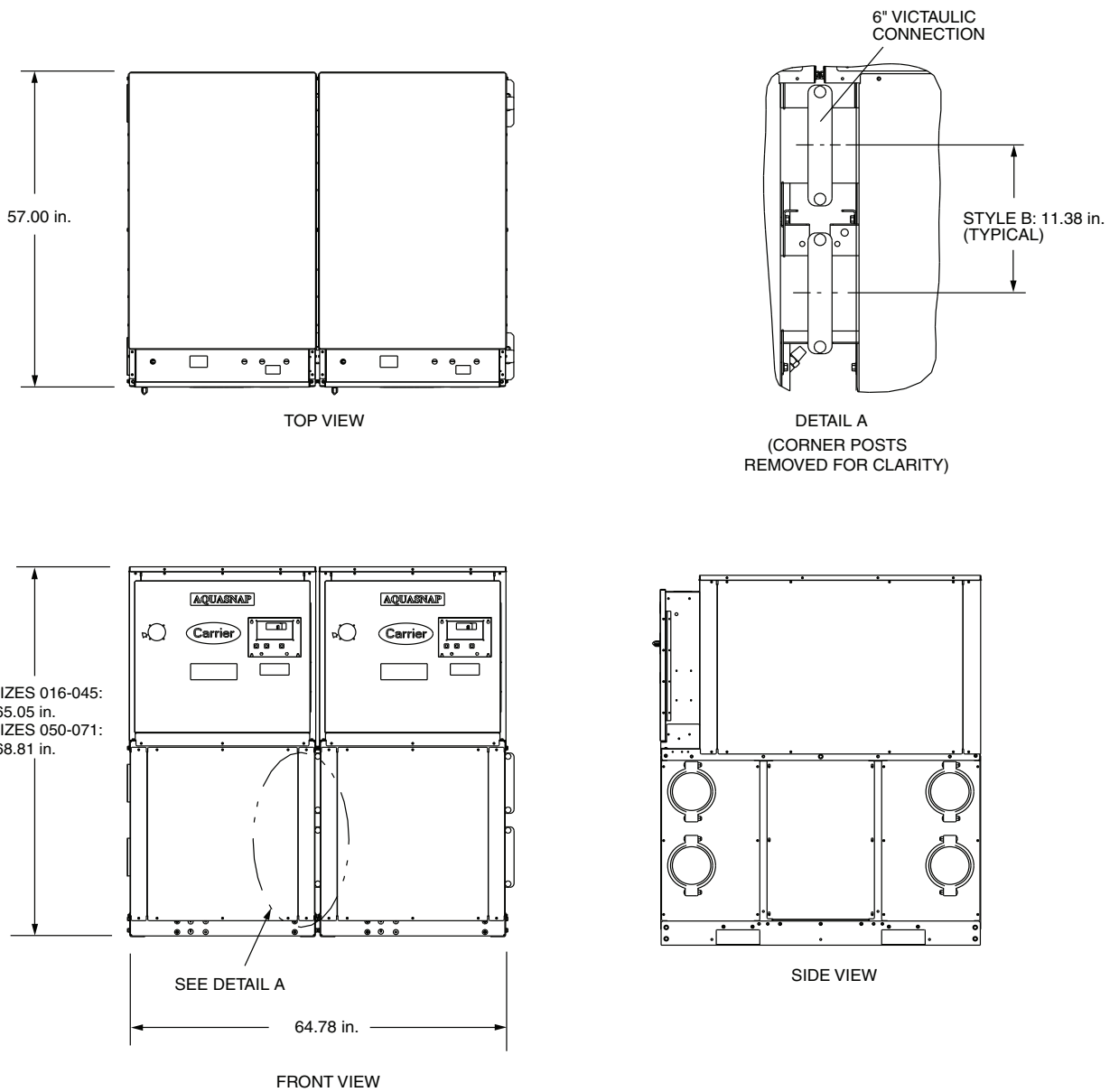

NOTE: Style B water manifold is used on 30MP050-071 units and 30MP016-045 units made starting February 2016 with a serial number beginning with 4515Q---- (example: Week 45, Year 2015, Q, sequence number).

Fig. 16 — Dimensions — 30MP Chiller Units Manifolder Together without Spacer Pipe (30MPW045 Shown)

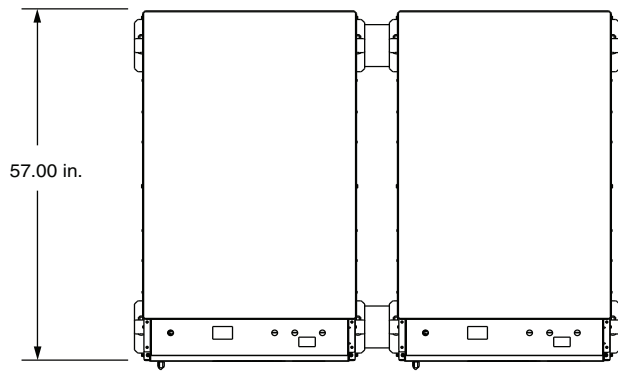

TOP VIEW

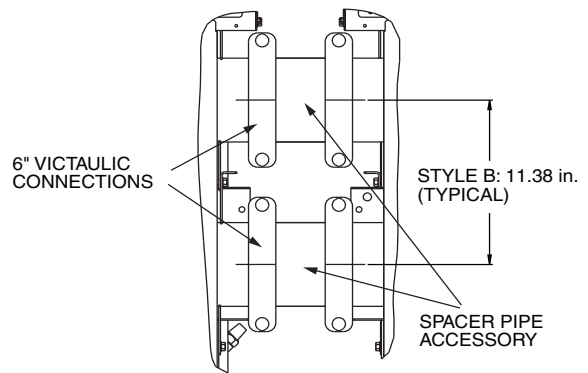

DETAIL A

(CORNER POSTS
REMOVED FOR CLARITY)

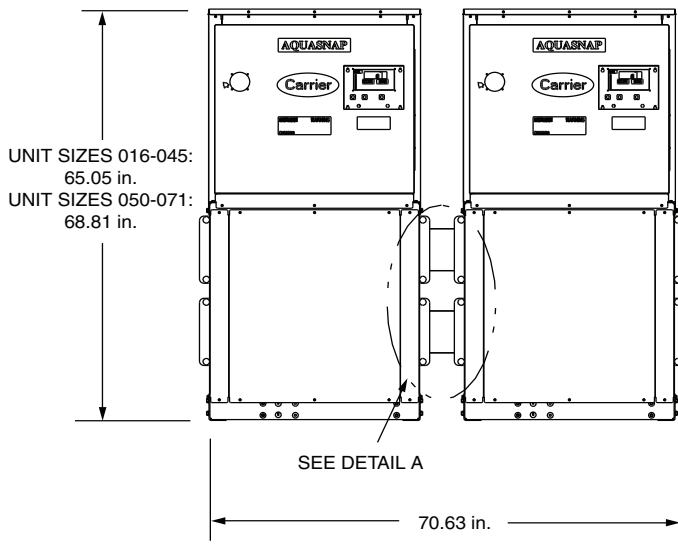

FRONT VIEW

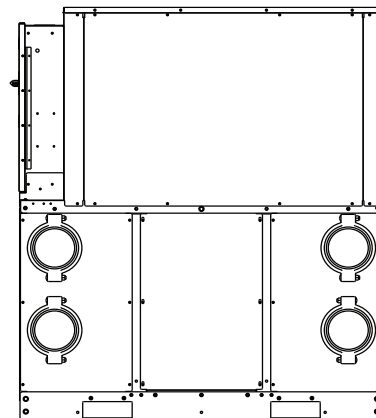

SIDE VIEW

NOTE: Style B water manifold is used on 30MP050-071 units and 30MP016-045 units made starting February 2016 with a serial number beginning with 4515Q---- (example: Week 45, Year 2015, Q, sequence number).

Fig. 17 — Dimensions — 30MP Chiller Units Manifolded Together with Accessory Spacer Pipe (30MPW045 Shown)

Table 1 — 30MPA Air-Cooled and 30MPW Liquid-Cooled 016-045 Units Physical Data — English

UNIT 30MPA,MPW	016**	020	030	032**	040	045
NOMINAL TONS	15	20	30	30	40	45
OPERATING WT (lb)						
MPA	—	702	755	—	928	978
MPA with Manifold	—	920	973	—	1146	1196
MPW	671	790	992	968	1214	1298
MPW with Manifold	1007	1226	1428	1404	1650	1734
REFRIGERANT (lb) CKT A / CKT B						
MPA*	—	10.7 / —	12.5 / —	—	14.7 / —	15.1 / —
MPW	11.0 / —	14.0 / —	29.0 / —	15.2 / 15.2	33.5 / —	41.5 / —
COMPRESSOR CKT A / CKT B						
				Scroll, Hermetic		
Quantity	2 / —	2	2	1/1	3	3
Speed (rpm, 60 Hz/50 Hz)	3500 / 2900	3500 / 2900	3500 / 2900	3500 / 2900	3500 / 2900	3500 / 2900
Compressor Nominal Tons (A1, A2/B1)	9.6 / —	10 / —	15 / —	15 / 15	13 / —	15 / —
Oil Charge (pt)	9.06 / —	13.8 / —	13.8 / —	6.9 / 6.9	20.6 / —	20.6 / —
Capacity Control — Standard						
No. of Steps	3	2	2	2	3	3
Minimum Step Capacity (%)	40	50	50	50	33	33
Capacity Control — Optional Hot Gas Bypass						
No. of Steps	4	3	3	3	4	4
Minimum Step Capacity (%)	20	25	34	34	21	22
Capacity Control — Optional Digital Compressor						
No. of Steps	22	22	22	22	33	33
Minimum Step Capacity (%)	8	15	15	15	10	10
EVAPORATOR						
Weight (lb, empty)	33	47	92	87	112	158
Net Fluid Volume (gal.)	1.1	1.2	2.8	2.4	3.1	4.7
Maximum Refrigerant Pressure (psig)	505	505	565	650	565	565
Maximum Fluid-Side Pressure (psig)	300	300	300	300	300	300
Evaporator Connections (in.)						
Inlet and Outlet (Victaulic IPS)	2	2	2 1/2	2 1/2	2 1/2	2 1/2
Drain (NPT)	1/2	1/2	1/2	1/2	1/2	1/2
Manifold Connections (in.)						
Inlet and Outlet (Victaulic IPS)	6	6	6	6	6	6
CONDENSER (30MPW Only)						
Weight (lb, empty)	53	53	185	163	216	241
Net Fluid Volume (gal.)	2.0	2.0	5.6	5.9	7.1	8.0
Maximum Refrigerant Pressure (psig)	650	650	650	650	650	650
Maximum Water-Side Pressure (psig)	300	300	300	300	300	300
Condenser Connections (in.)						
Inlet and Outlet (Victaulic IPS)	1 1/2	1 1/2	2	2	2	2
Manifold Connections (in.)						
Inlet and Outlet (Victaulic IPS)	6	6	6	6	6	6
CONDENSER REFRIGERANT CONNECTIONS (30MPA Only)						
Liquid Line (ODS) (in.)	—	1/2	5/8	—	5/8	5/8
Discharge Line (ODS) (in.)	—	1 3/8	1 3/8	—	1 5/8	1 5/8
CHASSIS DIMENSIONS (in.)						
Length	55	55	55	55	55	55
Width	32	32	32	32	32	32
Height	62.5	62.5	62.5	62.5	62.5	62.5
MINIMUM SYSTEM FLUID VOLUME (gal. per Ton)						
Normal Air Conditioning						
Standard	6	6	6	6	3	3
Optional Hot Gas Bypass	4	4	4	4	3	3
Optional Digital Compressor	3	3	3	3	3	3
Low Outdoor Ambient Cooling Operation (30MPA Units)						
Standard	10	10	10	10	6	6
Optional Hot Gas Bypass	10	10	10	10	6	6
Optional Digital Compressor	6	6	6	6	6	6
CAPACITY STEPS						
Step 1	100%	100%	100%	100%	100%	100%
Step 2	60%	50%	50%	50%	67%	67%
Step 3	40%	25%†	34%†	34%†	33%	33%
Step 4	20%†	—	—	—	21%†	22%†
MINIMUM FLOW RATES (gpm)						
Evaporator	22	28	43	43	55	64
Condenser	22	28	43	43	55	64
MAXIMUM FLOW RATES (gpm)						
Evaporator	74	97	148	148	188	220
Condenser	74	97	148	148	188	220

* 30MPA units (condenser-less) are shipped with nitrogen holding charge. Approximate cooler operating charge is shown.
 † With optional hot gas bypass.
 ** Models 016 and 032 are not available in an air-cooled version.

NOTES:
 1. Operating weight includes refrigerant operating charge and weight of fluid in the heat exchangers.
 2. Manifold option adds approximately 218 lb to the operating weight of 30MPA units and 436 lb to the operating weight of 30MPW units.
 3. 30MPW units are shipped with full operating charge.

Table 2 — 30MPA Air-Cooled and 30MPW Liquid-Cooled 050-071 Units Physical Data — English

UNIT 30MPA,MPW	050	055	060	065	071
NOMINAL TONS	50	55	60	65	71
OPERATING WT (lb)					
MPA	1398	1413	1437	1468	1506
MPA with Manifold	1616	1631	1655	1686	1724
MPW	1602	1617	1681	1712	1719
MPW with Manifold	2038	2053	2117	2148	2155
REFRIGERANT (lb)			R-410A		
MPA*	29.7	30.7	33.1	34.0	39.0
MPW	43.2	44.6	47.9	49.3	50.1
COMPRESSOR			Scroll, Hermetic		
Quantity	2	2	2	2	2
Speed (rpm, 60 Hz/50 Hz)	3500 / 2900	3500 / 2900	3500 / 2900	3500 / 2900	3500 / 2900
Compressor Nominal Tons (A1, A2)	25,25	25,32	25,35	25,40	32,40
Oil Charge (pt)	22.4	22.4	22.4	22.4	22.4
Capacity Control — Standard					
No. of Steps	2	2	2	2	2
Minimum Step Capacity (%)	50	44	42	38	44
Capacity Control — Optional Hot Gas Bypass					
No. of Steps	3	3	3	3	3
Minimum Step Capacity (%)	40	35	33	31	38
Capacity Control — Optional Digital Compressor					
No. of Steps	—	—	—	—	—
Minimum Step Capacity (%)	—	—	—	—	—
EVAPORATOR					
Weight (lb, empty)	143	143	167	167	190
Net Fluid Volume (gal.)	3.9	3.9	4.7	4.7	5.4
Maximum Refrigerant Pressure (psig)	650	650	650	650	650
Maximum Fluid-Side Pressure (psig)	300	300	300	300	300
Evaporator Connections (in.)					
Inlet and Outlet (Victaulic IPS)	2 ¹ / ₂	2 ¹ / ₂	2 ¹ / ₂	2 ¹ / ₂	2 ¹ / ₂
Drain (NPT)	1 ¹ / ₂	1 ¹ / ₂	1 ¹ / ₂	1 ¹ / ₂	1 ¹ / ₂
Manifold Connections (in.)					
Inlet and Outlet (Victaulic IPS)	6	6	6	6	6
CONDENSER (30MPW Only)					
Weight (lb, empty)	204	204	244	244	244
Net Fluid Volume (gal.)	5.2	5.2	6.3	6.3	6.3
Maximum Refrigerant Pressure (psig)	653	653	653	653	653
Maximum Water-Side Pressure (psig)	300	300	300	300	300
Condenser Connections (in.)					
Inlet and Outlet (Victaulic IPS)	2 ¹ / ₂	2 ¹ / ₂	2 ¹ / ₂	2 ¹ / ₂	2 ¹ / ₂
Drain (NPT)	—	—	—	—	—
Manifold Connections (in.)					
Inlet and Outlet (Victaulic IPS)	6	6	6	6	6
CONDENSER REFRIGERANT CONNECTIONS (30MPA Only)					
Liquid Line (ODS) (in.)	1 ¹ / ₈	1 ¹ / ₈	1 ¹ / ₈	1 ¹ / ₈	1 ¹ / ₈
Discharge Line (ODS) (in.)	1 ⁵ / ₈	1 ⁵ / ₈	1 ⁵ / ₈	1 ⁵ / ₈	1 ⁵ / ₈
CHASSIS DIMENSIONS (in.)					
Length	55.0	55.0	55.0	55.0	55.0
Width	32.0	32.0	32.0	32.0	32.0
Height	66.3	66.3	66.3	66.3	66.3
MINIMUM SYSTEM FLUID VOLUME (gal. per Ton)					
Normal Air Conditioning					
Standard	6	6	6	6	6
Optional Hot Gas Bypass	4	4	4	4	4
Optional Digital Compressor	—	—	—	—	—
Low Outdoor Ambient Cooling Operation					
Standard	10	10	10	10	10
Optional Hot Gas Bypass	10	10	10	10	10
Optional Digital Compressor	—	—	—	—	—
CAPACITY STEPS					
Step 1	100%	100%	100%	100%	100%
Step 2	50%	44%	42%	38%	44%
Step 3	40%†	35%†	33%†	31%†	38%†
Step 4	—	—	—	—	—
MINIMUM FLOW RATES (gpm)					
Evaporator	70	77	84	91	104
Condenser	70	77	84	91	104
MAXIMUM FLOW RATES (gpm)					
Evaporator	238	262	286	309	354
Condenser	238	262	286	309	354

* 30MPA units (condenser-less) are shipped with nitrogen holding charge.
Approximate cooler operating charge is shown.
† With optional hot gas bypass.

NOTES:
1. Operating weight includes refrigerant operating charge and weight of fluid in the heat exchangers.
2. Manifold option adds approximately 218 lb to the operating weight of 30MPA units and 436 lb to the operating weight of 30MPW units.
3. 30MPW units are shipped with full operating charge.

Table 3 — 30MPA Air-Cooled and 30MPW Liquid-Cooled 016-045 Units Physical Data — SI

UNIT 30MPA,MPW	016**	020	030	032**	040	045
NOMINAL kW	53	70	106	106	141	158
OPERATING WT (kg)						
MPA	—	316	340	—	418	440
MPA with Manifold	—	414	438	—	516	538
MPW	302	356	446	436	546	584
MPW with Manifold	498	552	643	632	743	780
REFRIGERANT (kg) CKT A / CKT B						
MPA*	—	4.9 / —	5.7 / —	—	6.7 / —	6.8 / —
MPW	5.0 / —	6.3 / —	13.1 / —	6.84 / 6.84	15.1 / —	18.7 / —
COMPRESSOR CKT A / CKT B						
Quantity	2	2	2	2	3	3
Speed (r/s, 60 Hz/50 Hz)	58 / 48	58 / 48	58 / 48	58 / 48	58 / 48	58 / 48
Compressor Nominal kW (A1, A2/B1)	31.5,21 / —	35 / —	53 / —	53 / 53	45 / —	53 / —
Oil Charge (L)	4.3 / —	6.5 / —	6.5 / —	3.24 / 3.24	9.8 / —	9.8 / —
Capacity Control — Standard						
No. of Steps	3	2	2	3	3	3
Minimum Step Capacity (%)	40	50	50	40	33	33
Capacity Control — Optional Hot Gas Bypass						
No. of Steps	4	3	3	4	4	4
Minimum Step Capacity (%)	20	25	34	20	21	22
Capacity Control — Optional Digital Compressor						
No. of Steps	22	22	22	22	33	33
Minimum Step Capacity (%)	8	15	15	8	10	10
EVAPORATOR						
Weight (kg, empty)	14.85	21.15	41.6	39.15	50.4	71.1
Net Fluid Volume (L)	4.1	4.7	10.5	8.9	11.8	17.9
Maximum Refrigerant Pressure (kPa)	3482	3482	3896	4479	3896	3896
Maximum Fluid-Side Pressure (kPa)	2068	2068	2068	2068	2068	2068
Evaporator Connections (in.)						
Inlet and Outlet (Victaulic IPS)	2	2	2 ¹ / ₂	2	2 ¹ / ₂	2 ¹ / ₂
Drain (NPT)	1/2	1/2	1/2	1/2	1/2	1/2
Manifold Connections (in.)						
Inlet and Outlet (Victaulic IPS)	6	6	6	6	6	6
CONDENSER (30MPW Only)						
Weight (kg, empty)	23.9	23.9	83.3	73.4	97.2	108.5
Net Fluid Volume (L)	7.5	7.5	21.3	22.4	26.85	30.2
Maximum Refrigerant Pressure (kPa)	4479	4481	4481	4479	4481	4481
Maximum Water-Side Pressure (kPa)	2067	2068	2068	2067	2068	2068
Condenser Connections (in.)						
Inlet and Outlet (Victaulic IPS)	1 ¹ / ₂	1 ¹ / ₂	2	2	2	2
Manifold Connections (in.)						
Inlet and Outlet (Victaulic IPS)	6	6	6	6	6	6
CONDENSER REFRIGERANT CONNECTIONS (30MPA Only)						
Liquid Line (ODS) (in.)	—	1/2	5/8	—	5/8	5/8
Discharge Line (ODS) (in.)	—	1 ³ / ₈	1 ³ / ₈	—	1 ⁵ / ₈	1 ⁵ / ₈
CHASSIS DIMENSIONS (mm)						
Length	1397	1397	1397	1397	1397	1397
Width	813	813	813	813	813	813
Height	1588	1588	1588	1588	1588	1588
MINIMUM SYSTEM FLUID VOLUME (L per kW)						
Normal Air Conditioning						
Standard	6.5	6.5	6.5	6.5	3.3	3.3
Optional Hot Gas Bypass	4.3	4.3	4.3	4.3	3.3	3.3
Optional Digital Compressor	3.3	3.3	3.3	3.3	3.3	3.3
Low Outdoor Ambient Cooling Operation (30MPA Units)						
Standard	10.8	10.8	10.8	10.8	6.5	6.5
Optional Hot Gas Bypass	10.8	10.8	10.8	10.8	6.5	6.5
Optional Digital Compressor	6.5	6.5	6.5	6.5	6.5	6.5
CAPACITY STEPS						
Step 1	100%	100%	100%	100%	100%	100%
Step 2	60%	50%	50%	50%	67%	67%
Step 3	40%	25%†	34%†	34%†	33%	33%
Step 4	20%†	—	—	—	21%†	22%†
MINIMUM FLOW RATES (L/s)						
Evaporator	1.4	1.8	2.7	2.7	3.5	4.0
Condenser	1.4	1.8	2.7	2.7	3.5	4.0
MAXIMUM FLOW RATES (L/s)						
Evaporator	4.7	6.1	9.3	9.3	11.9	13.9
Condenser	4.7	6.1	9.3	9.3	11.9	13.9

* 30MPA units (condenser-less) are shipped with nitrogen holding charge. Approximate cooler operating charge is shown.
† With optional hot gas bypass.
** Models 016 and 032 are not available in an air-cooled version.

NOTES:
1. Operating weight includes refrigerant operating charge and weight of fluid in the heat exchangers.
2. Manifold option adds approximately 99 kg to the operating weight of 30MPA units and 198 kg to the operating weight of 30MPW units.
3. 30MPW units are shipped with full operating charge.

Table 4 — 30MPA Air-Cooled and 30MPW Liquid-Cooled 050-071 Units Physical Data — SI

UNIT 30MPA,MPW	050	055	060	065	071
NOMINAL kW	177	194	212	229	250
OPERATING WT (kg)					
MPA	634	641	652	666	683
MPA with Manifold	733	740	750	765	782
MPW	727	733	762	777	780
MPW with Manifold	924	931	960	974	978
REFRIGERANT (kg)			R-410A		
MPA*	13.5	14.0	15.0	15.5	17.7
MPW	19.6	20.3	21.6	22.4	22.8
COMPRESSOR			Scroll, Hermetic		
Quantity	2	2	2	2	2
Speed (r/s, 60 Hz/50 Hz)	58/48	58/48	58/48	58/48	58/48
Compressor Nominal kW (A1, A2)	88,88	88,113	88,124	88,141	113,141
Oil Charge (L)	10.5	10.5	10.5	10.5	10.5
Capacity Control — Standard					
No. of Steps	2	2	2	2	2
Minimum Step Capacity (%)	50	44	42	38	44
Capacity Control — Optional Hot Gas Bypass					
No. of Steps	3	3	3	3	3
Minimum Step Capacity (%)	40	35	33	31	38
Capacity Control — Optional Digital Compressor					
No. of Steps	—	—	—	—	—
Minimum Step Capacity (%)	—	—	—	—	—
EVAPORATOR					
Weight (kg, empty)	64.4	64.4	75.2	75.2	85.5
Net Fluid Volume (L)	14.1	14.1	17.0	17.0	19.6
Maximum Refrigerant Pressure (kPa)	4481	4481	4481	4481	4481
Maximum Fluid-Side Pressure (kPa)	2070.0	2070.0	2070.0	2070.0	2070.0
Water Connections (in.)					
Inlet and Outlet (Victaulic IPS)	2½	2½	2½	2½	2½
Drain (NPT)	½	½	½	½	½
Manifold Connections (in.)					
Inlet and Outlet (Victaulic IPS)	6	6	6	6	6
CONDENSER (30MPW Only)					
Weight (kg, empty)	91.8	91.8	109.8	109.8	109.8
Net Fluid Volume (L)	18.9	18.9	22.8	22.8	22.8
Maximum Refrigerant Pressure (kPa)	4505.7	4505.7	4505.7	4505.7	4505.7
Maximum Water-Side Pressure (kPa)	2070.0	2070.0	2070.0	2070.0	2070.0
Water Connections (in.)					
Inlet and Outlet (Victaulic IPS)	2½	2½	2½	2½	2½
Drain (NPT)	—	—	—	—	—
Manifold Connections (in.)					
Inlet and Outlet (Victaulic IPS)	6	6	6	6	6
CONDENSER REFRIGERANT CONNECTIONS (30MPA Only)					
Liquid Line (ODS) (in.)	1⅛	1⅛	1⅛	1⅛	1⅛
Discharge Line (ODS) (in.)	1⅝	1⅝	1⅝	1⅝	1⅝
CHASSIS DIMENSIONS (mm)					
Length	1397	1397	1397	1397	1397
Width	813	813	813	813	813
Height	1685	1685	1685	1685	1685
MINIMUM SYSTEM FLUID VOLUME (L per kW)					
Normal Air Conditioning					
Standard	6.5	6.5	6.5	6.5	6.5
Optional Hot Gas Bypass	4.3	4.3	4.3	4.3	4.3
Optional Digital Compressor	—	—	—	—	—
Low Outdoor Ambient Cooling Operation					
Standard	10.8	10.8	10.8	10.8	10.8
Optional Hot Gas Bypass	10.8	10.8	10.8	10.8	10.8
Optional Digital Compressor	—	—	—	—	—
CAPACITY STEPS					
Step 1	100%	100%	100%	100%	100%
Step 2	50%	44%	42%	38%	44%
Step 3	40%†	35%†	33%†	31%†	38%†
Step 4	—	—	—	—	—
MINIMUM FLOW RATES (L/s)					
Evaporator	4.5	4.9	5.4	5.8	6.7
Condenser	4.5	4.9	5.4	5.8	6.7
MAXIMUM FLOW RATES (L/s)					
Evaporator	15.2	16.8	18.3	19.8	22.7
Condenser	15.2	16.8	18.3	19.8	22.7

* 30MPA units (condenser-less) are shipped with nitrogen holding charge.
 † Approximate cooler operating charge is shown.
 ‡ With optional hot gas bypass.

NOTES:
 1. Operating weight includes refrigerant operating charge and weight of fluid in the heat exchangers.
 2. Manifold option adds approximately 98.9 kg to the operating weight of 30MPA units and 197.7 kg to the operating weight of 30MPW units.
 3. 30MPW units are shipped with full operating charge.

Unit Mounting Requirements — The mounting hole weights from Fig. 18 should be used for calculating weights for units connected via common water manifold piping (multi-chiller applications) and using the Vibration Isolator Springs Accessory Kit.

Multiple chiller applications using the Vibration Isolator Springs Accessory Kit should be set on a mounting frame, which should then be installed on the isolator springs. I-beam or square metal tubing are acceptable materials for the

mounting frame. Each chiller **MUST** be supported in the center (under the heat exchangers) by the mounting frame; however, isolators are only necessary at the four corners of each unit. Use Fig. 18 for the corner weights of each when supported in four locations.

For standalone units (chillers which are not connected via common water piping), 30MP 016-045 must be supported at the four corner locations shown in Fig. 18. 30MP 050-071 must be supported at the six locations shown in Fig. 19.

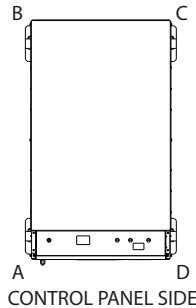

ESTIMATED WEIGHT DISTRIBUTION AT EACH MOUNTING HOLE — lb

UNIT 30MP	MOUNTING HOLE (lb)			
	A	B	C	D
A020	252	125	226	99
A030	258	139	239	119
A040	315	183	281	149
A045	320	196	293	169
A050	391	348	351	308
A055	396	352	355	310
A060	398	358	361	320
A065	409	365	369	325
A071	416	374	379	337
W016	202	115	221	133
W020	243	142	253	152
W030	313	187	309	183
W032	305	180	304	179
W040	393	237	370	214
W045	413	256	393	235
W050	484	398	403	317
W055	490	402	407	319
W060	508	424	416	332
W065	519	432	424	337
W071	516	432	427	344

ESTIMATED WEIGHT DISTRIBUTION AT EACH MOUNTING HOLE — kg

UNIT 30MP	MOUNTING HOLE (kg)			
	A	B	C	D
A020	114	57	102	45
A030	117	63	108	54
A040	143	83	127	67
A045	145	89	133	76
A050	177	158	159	140
A055	179	159	161	141
A060	180	162	163	145
A065	185	166	167	147
A071	189	169	172	153
W016	92	52	100	60
W020	110	65	114	69
W030	142	85	140	83
W032	138	82	138	81
W040	178	108	167	97
W045	187	116	178	107
W050	219	180	183	143
W055	222	182	184	144
W060	230	192	189	150
W065	235	196	192	152
W071	234	196	193	156

UNIT 30MP WITH MANIFOLD	MOUNTING HOLE (lb)			
	A	B	C	D
A020	258	326	134	202
A030	266	339	148	220
A040	324	381	192	249
A045	331	394	204	267
A050	445	444	364	363
A055	451	448	368	365
A060	453	453	374	375
A065	463	461	382	380
A071	471	470	392	391
W016	312	323	230	242
W020	353	351	262	260
W030	423	395	319	291
W032	415	389	313	287
W040	502	446	379	323
W045	523	464	402	344
W050	594	505	514	425
W055	599	509	517	427
W060	618	532	527	441
W065	629	539	535	445
W071	626	540	538	452

UNIT 30MP WITH MANIFOLD	MOUNTING HOLE (kg)			
	A	B	C	D
A020	117	148	61	91
A030	121	153	67	100
A040	147	173	87	113
A045	150	178	93	121
A050	202	201	165	164
A055	204	203	167	165
A060	205	205	169	170
A065	210	209	173	172
A071	213	213	178	177
W016	141	146	104	109
W020	160	159	119	118
W030	192	179	144	132
W032	188	176	142	130
W040	228	202	172	146
W045	237	210	182	156
W050	269	229	233	192
W055	272	231	234	193
W060	280	241	239	200
W065	285	244	242	202
W071	283	245	244	205

Fig. 18 — Mounting Hole Weight Distribution (At Four Locations)

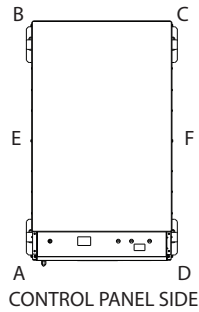

ESTIMATED WEIGHT DISTRIBUTION AT EACH MOUNTING HOLE — lb

ESTIMATED WEIGHT DISTRIBUTION AT EACH MOUNTING HOLE — kg

UNIT 30MP	MOUNTING HOLE (lb)					
	A	B	C	D	E	F
A020	159	126	75	108	142	92
A030	166	132	86	119	149	103
A040	199	166	111	143	182	127
A045	204	172	122	154	188	138
A050	247	246	219	220	247	219
A055	250	249	221	222	250	221
A060	253	252	226	227	253	226
A065	259	258	230	231	259	231
A071	265	263	237	239	264	238
W016	141	106	83	118	123	100
W020	165	128	98	135	147	117
W030	207	167	123	164	187	144
W032	203	162	120	161	182	140
W040	254	210	151	195	232	173
W045	269	223	164	209	246	187
W050	296	294	238	240	295	239
W055	299	297	240	242	298	241
W060	308	311	252	250	309	251
W065	314	317	256	253	316	255
W071	314	316	259	257	315	258

UNIT 30MP	MOUNTING HOLE (kg)					
	A	B	C	D	E	F
A020	72	57	34	49	65	41
A030	75	60	39	54	67	46
A040	90	75	50	65	83	58
A045	93	78	55	70	85	62
A050	112	112	99	100	112	99
A055	113	113	100	100	113	100
A060	115	114	102	103	114	103
A065	117	117	104	105	117	104
A071	120	119	107	108	120	108
W016	64	48	37	53	56	45
W020	75	58	44	61	66	53
W030	94	76	56	74	85	65
W032	92	73	54	73	83	64
W040	115	95	68	88	105	78
W045	122	101	74	95	111	85
W050	134	133	108	109	134	108
W055	135	135	109	110	135	109
W060	140	141	114	113	140	114
W065	142	144	116	115	143	115
W071	142	143	117	116	143	117

UNIT 30MP WITH MANIFOLD	MOUNTING HOLE (lb)					
	A	B	C	D	E	F
A020	131	195	176	112	163	144
A030	138	202	186	123	170	154
A040	172	235	210	147	204	178
A045	178	241	220	157	210	189
A050	270	296	269	242	283	256
A055	273	299	271	244	286	258
A060	276	302	276	250	289	263
A065	282	308	280	254	295	267
A071	288	313	287	261	301	274
W016	181	212	188	157	196	173
W020	205	234	204	174	220	189
W030	247	273	229	203	260	216
W032	243	268	225	200	255	213
W040	294	316	256	234	305	245
W045	308	329	269	249	319	259
W050	369	367	310	313	368	311
W055	372	370	312	315	371	313
W060	382	383	324	323	382	323
W065	388	389	328	327	389	327
W071	388	388	331	330	388	330

UNIT 30MP WITH MANIFOLD	MOUNTING HOLE (kg)					
	A	B	C	D	E	F
A020	59	88	80	51	74	65
A030	63	91	84	56	77	70
A040	78	107	95	67	92	81
A045	81	109	100	71	95	85
A050	122	134	122	110	128	116
A055	124	136	123	111	130	117
A060	125	137	125	113	131	119
A065	128	140	127	115	134	121
A071	130	142	130	118	136	124
W016	82	96	85	71	89	78
W020	93	106	92	79	100	86
W030	112	124	104	92	118	98
W032	110	121	102	91	116	96
W040	133	143	116	106	138	111
W045	140	149	122	113	144	117
W050	167	166	140	142	167	141
W055	169	167	141	143	168	142
W060	173	174	147	146	173	146
W065	176	176	149	148	176	148
W071	176	176	150	149	176	150

Fig. 19 — Mounting Hole Weight Distribution (At Six Locations)

Step 1 — Inspect Shipment — Inspect the unit for damage or missing parts. If damaged, or if shipment is incomplete, file a claim immediately with the shipping company.

CAUTION

Unit is top heavy. Unit may tip if handled without care. Damage to unit or injury may result.

Step 2 — Position the Unit — The unit may be moved by means of rollers under the rails or a forklift truck.

If accessory mobility kit is to be used, install this accessory after bringing the unit into the building and before moving the unit to its final location per installation instructions provided with the accessory. The factory-installed mobility kit option consists of 6 swivel-type wheels that are field-mounted to the legs of the unit. See Fig. 20.

NOTE: The wheels are equipped with a thumb-screw brake.

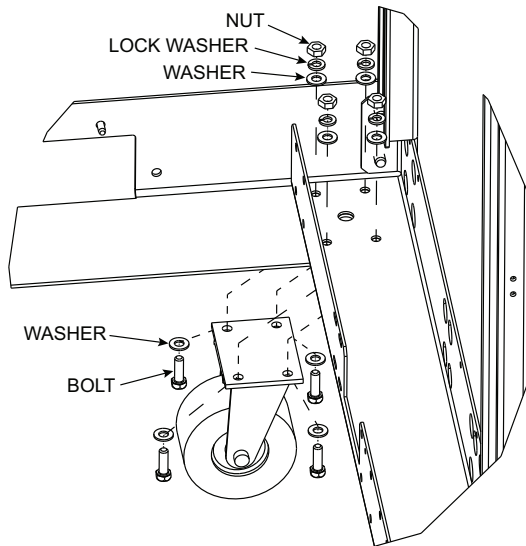

Fig. 20 — Mobility Kit

Step 3 — Place the Unit

NOTE: These units are not suitable for unprotected outdoor use.

Carrier recommends that these units be located in the basement or on the ground floor. However, if it is necessary to locate the unit on an upper floor, be sure the structure has been designed to support the unit weight. If necessary, add structural support to floor. Also, be sure the surface for installation is level. Refer to Fig. 6-18 for space requirements and weight distribution.

Only electrical power connections, controls, water connections for condenser, fluid connections for evaporator, and strainer installation are required for 30MPW installation. Installation of 30MPA units varies only in field piping required for the remote condenser instead of a water connection.

When the unit is in its final position, remove the packaging and remove the mobility kit wheels (if equipped). Remove the 3/8-in. wheel nuts to remove the wheels from the unit legs. Level the unit (using a level), and bolt the unit to the floor or pad.

If unit is to be mounted on unit external vibration isolators, follow the mounting instructions included with the accessory vibration isolator.

If the unit has accessory leveling kit installed, follow the instructions provided with the accessory to make sure the unit is level and in the correct position. The leveling kit is included with all manifold units.

Step 4 — Check Compressor Mounting

30MP016-030, 040-045 UNITS — As shipped, 30MP016-030 units with two compressors are held down with six bolts through rubber grommets. All 30MP040,045 units with three compressors are held down with eight bolts per pair through grommets.

After unit is installed, verify that mounting bolt torque is 7 to 10 ft-lb (9 to 14 Nm). See Fig. 21.

30MP032 UNITS — For 30MP032 units, eight RED shipping bolts must be removed from the compressor mounting rail. These RED bolts are for shipping purposes only, see Fig. 22.

30MP050-071 UNITS — For 30MP050-071 units, two RED shipping bolts from the compressor mounting rail must be removed. These RED bolts are for shipping purposes only. See Fig. 23.

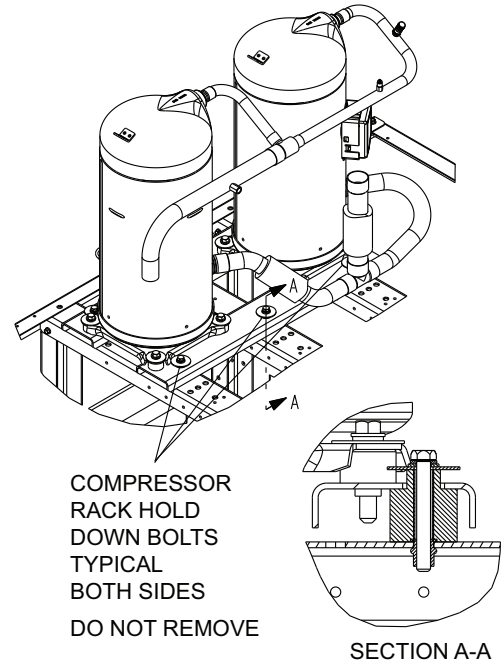

UNIT SIZES 016-030

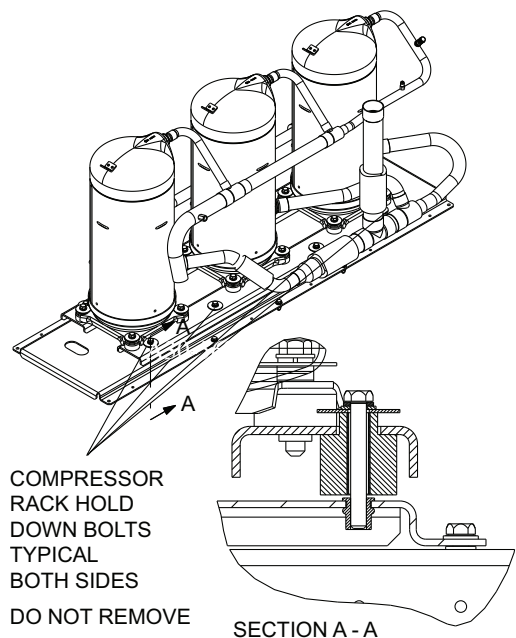

UNIT SIZES 040-045

Fig. 21 — Compressor Holddown Bolts (Sizes 016-030, 040-045)

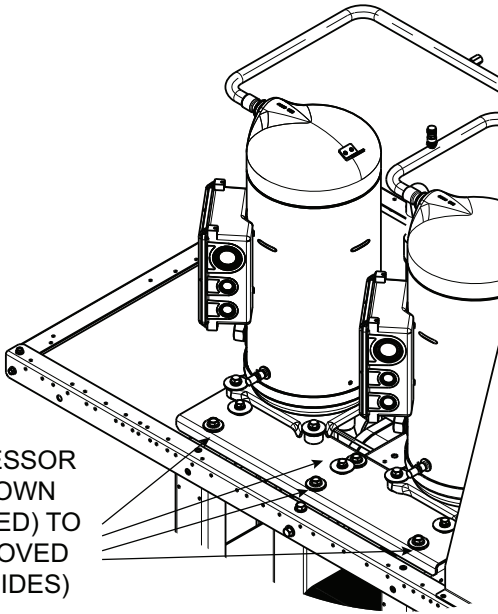

COMPRESSOR
HOLDDOWN
BOLTS (RED) TO
BE REMOVED
(BOTH SIDES)

NOTE: For 30MP032 units, remove eight RED shipping bolts from compressor mounting rail. These RED bolts are for shipping purposes only.

Fig. 22 — Compressor Shipping Bolts (Size 032 Only)

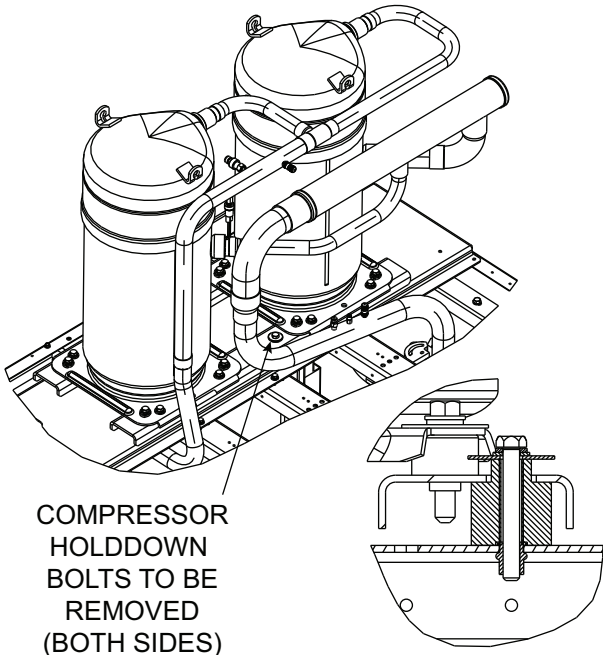

COMPRESSOR
HOLDDOWN
BOLTS TO BE
REMOVED
(BOTH SIDES)

NOTE: For 30MP050-071 units, RED bolts from the unit and the compressor mounting rail MUST BE REMOVED. These RED bolts are for shipping purposes only.

Fig. 23 — Compressor Shipping Bolts (Sizes 050-071 Only)

Step 5 — Make Piping Connections — See Fig. 24-27 for typical piping applications.

UNITS WITHOUT MANIFOLD — All sizes have Victaulic IPS (Iron Pipe Size) water connections as shown in Tables 1-4.

30MPA SYSTEM CONDENSER — For detailed condenser piping installation instructions for 30MPA systems, refer to separate instructions packaged with the remote condenser units.

Condenser refrigerant piping for 30MPA units should be sized to minimize the amount of refrigerant required. Consider the length of piping required between the condenser and indoor unit, the amount of liquid lift, and the compressor oil return. The maximum length of refrigerant piping is 200 ft (61m). Discharge and liquid lines should be sized in accordance with Table 5. Liquid line refrigerant chart is shown in Table 6. Double discharge risers may be required for proper oil return if condenser is located above the chiller and if hot gas bypass is installed, or if unit is used for medium temperature brine application. See Table 7 and Fig. 28.

IMPORTANT: Do NOT bury refrigerant piping underground. Failure to comply could result in equipment damage.

Table 5 — Single Circuit 30MPA Line Sizing Chart

30MPA UNIT	UNIT REFRIGERANT CONNECTIONS (CHILLER CONNECTION SIZE) ODS		TOTAL LINEAR LENGTH OF INTERCONNECTING PIPE FT (M)						
			0 - 50 (0 - 15.4) EQUIV. PIPE LENGTH = 75 FT		50 - 100 (15.4 - 30.5) EQUIV. PIPE LENGTH = 150 FT		100 - 200 (30.5 - 61.0) EQUIV. PIPE LENGTH = 300 FT		
	L (in.)	D (in.)	L (in.)	D (in.)	L (in.)	D (in.)	L (in.)	D (in.)	
020	1/2	1 3/8	5/8	1 3/8	5/8	1 3/8	7/8	1 3/8	1 3/8
030	5/8	1 3/8	7/8	1 3/8	7/8	1 3/8	7/8	1 3/8	1 3/8
040	5/8	1 5/8	7/8	1 5/8	7/8	1 5/8	1 1/8	1 5/8	1 5/8
045	5/8	1 5/8	7/8	1 5/8	7/8	1 5/8	1 1/8	1 5/8	1 5/8
050	1 1/8	1 5/8	1 1/8	1 5/8	1 1/8	2 1/8	1 3/8	2 1/8	2 1/8
055	1 1/8	1 5/8	1 1/8	1 5/8	1 1/8	2 1/8	1 3/8	2 1/8	2 1/8
060	1 1/8	1 5/8	1 1/8	2 1/8	1 1/8	2 1/8	1 3/8	2 5/8	2 5/8
065	1 1/8	1 5/8	1 1/8	2 1/8	1 1/8	2 1/8	1 3/8	2 5/8	2 5/8
071	1 1/8	1 5/8	1 1/8	2 1/8	1 1/8	2 1/8	1 3/8	2 5/8	2 5/8

LEGEND

- D** — Discharge Line Size (discharge line size is equal to the chiller connection size)
- L** — Liquid Line Size (liquid line size is equal to or greater than the chiller connection size)

NOTE: Shaded areas indicate double discharge riser required if unit is equipped with hot gas bypass or operation below 40°F LWT (Leaving Water Temperature). All units with digital compressors require double discharge riser.

Table 6 — Liquid Line Refrigerant Chart

PIPE DIAMETER (in.)	POUNDS PER 10 LINEAR FEET (KG PER 3 M)
1/2	0.6 (0.27)
5/8	1.0 (0.45)
7/8	2.0 (0.91)
1 1/8	3.5 (1.58)
1 3/8	5.1 (2.32)

Table 7 — Double Discharge Riser Data

30MPA UNIT	TOTAL LINEAR LENGTH OF INTERCONNECTING PIPE FT (M)		MINIMUM TONNAGE WITH DOUBLE RISER
	0 - 200 (0 - 61.0)		
	RISER A (in.)	RISER B (in.)	
020	7/8	1 1/8	1.86
030	7/8	1 1/8	1.86
040	7/8	1 3/8	1.86
045	7/8	1 3/8	1.86
050	1 5/8	1 5/8	3.16
055	1 5/8	1 5/8	3.16
060	1 5/8	2 1/8	3.16
065	1 5/8	2 1/8	3.16
071	1 5/8	2 1/8	3.16

NOTE: All pipe sizes are OD.

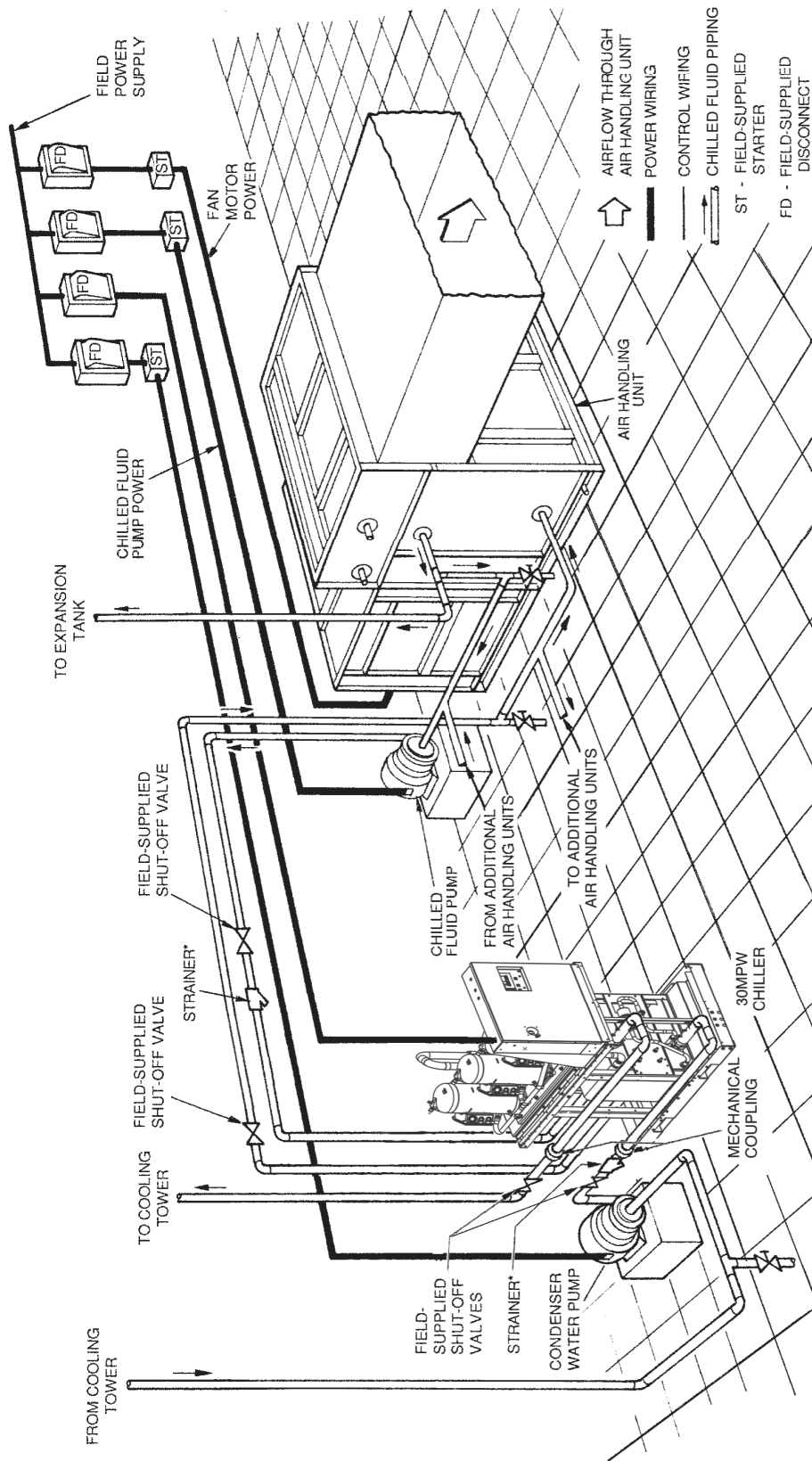

NOTES:

1. Chiller must be installed levelly to maintain proper compressor oil return.
2. Wiring and piping shown are general points-of-connection guides only and are not intended for a specific installation. Wiring and piping shown are for a quick overview of system and are not in accordance with recognized standards.
3. All wiring must comply with applicable local and national codes.
4. All piping must follow standard piping techniques. Refer to Carrier System Design Manual or appropriate ASHRAE (American Society of Heating, Refrigerating, and Air-Conditioning Engineers) handbook for details.
5. See product data for minimum system fluid volume. This system may require the addition of a holding tank to ensure adequate volume.
6. Operating environment — Chiller should be installed in an indoor environment where the ambient temperature is between 40 to 104°F (4 to 40°C) with a relative humidity (non-condensing) of 95% or less. To ensure that electrical components operate properly, do not locate the chiller in an area exposed to dust, dirt, corrosive fumes, or excessive heat and humidity.

Fig. 24 — Liquid-Cooled Typical Piping and Wiring, 30MPW Units Shown

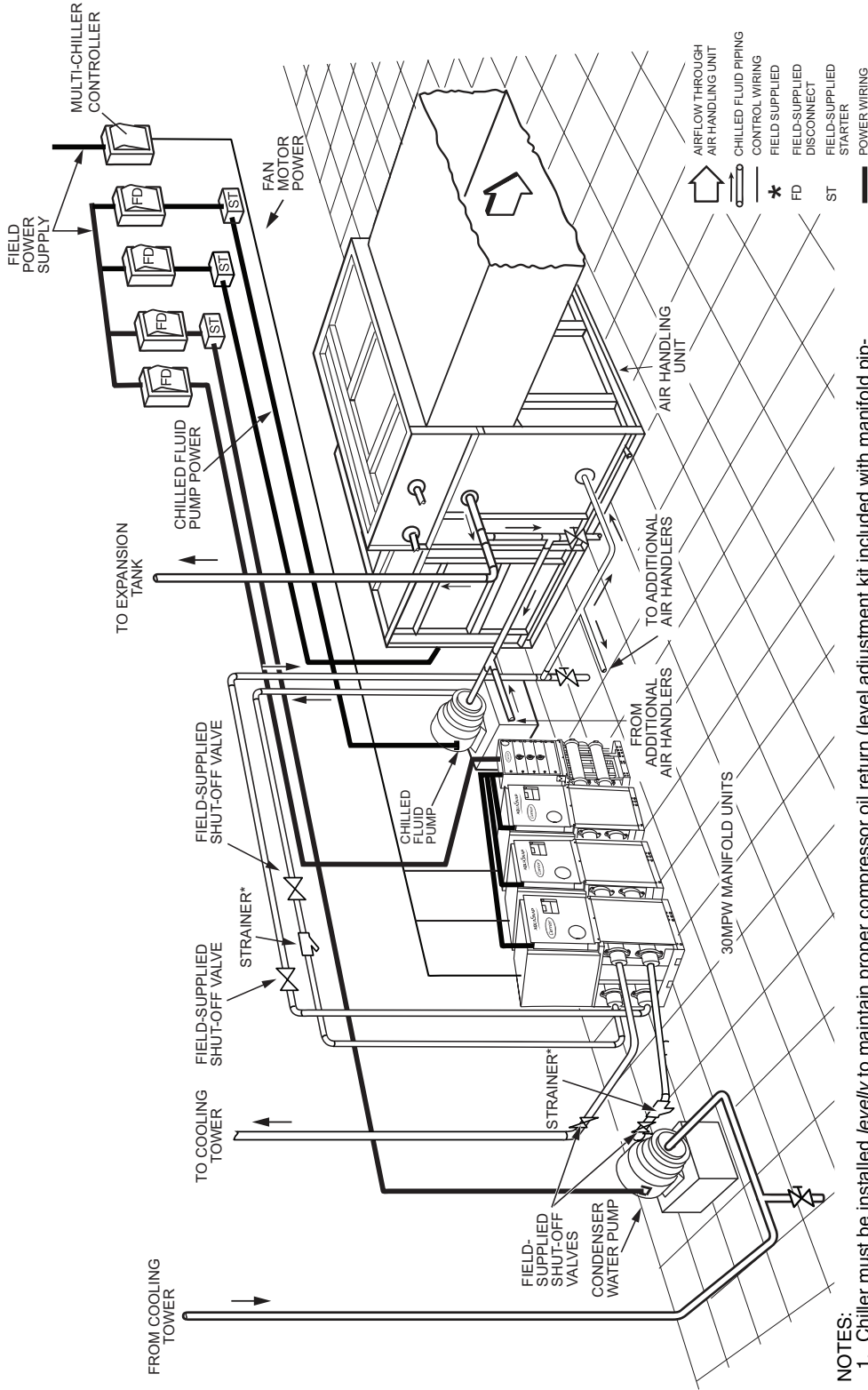

NOTES:

1. Chiller must be installed *levelly* to maintain proper compressor oil return (level adjustment kit included with manifold piping kit (option)).
2. Wiring and piping shown are general points-of-connection guides only and are not intended for a specific installation. Wiring and piping shown are for a quick overview of system and are not in accordance with recognized standards.
3. All wiring must comply with applicable local and national codes.
4. All piping must follow standard piping techniques. Refer to Carrier System Design Manual or appropriate ASHRAE (American Society of Heating, Refrigerating, and Air-Conditioning Engineers) handbook for details.
5. See product data for minimum system fluid volume. This system may require the addition of a holding tank to ensure adequate volume.
6. Operating environment — Chiller should be installed in an indoor environment where the ambient temperature is between 40 to 104°F (4 to 40°C) with a relative humidity (non-condensing) of 95% or less. To ensure that electrical components operate properly, do not locate the chiller in an area exposed to dust, dirt, corrosive fumes, or excessive heat and humidity.

Fig. 25 — Manifold Typical Piping and Wiring, 30MPW Units Shown

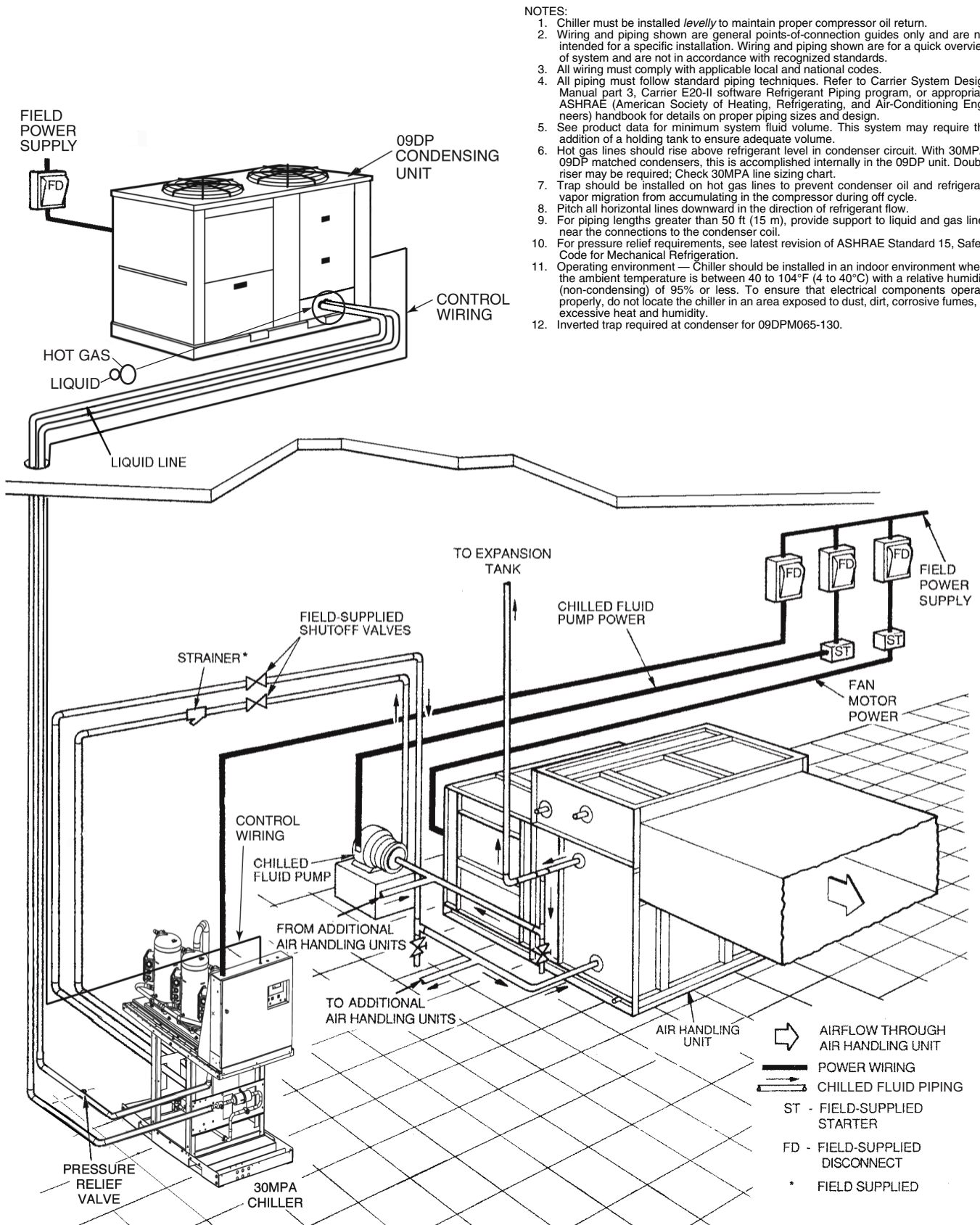

NOTES:

1. Chiller must be installed *levelly* to maintain proper compressor oil return.
2. Wiring and piping shown are general points-of-connection guides only and are not intended for a specific installation. Wiring and piping shown are for a quick overview of system and are not in accordance with recognized standards.
3. All wiring must comply with applicable local and national codes.
4. All piping must follow standard piping techniques. Refer to Carrier System Design Manual part 3, Carrier E20-II software Refrigerant Piping program, or appropriate ASHRAE (American Society of Heating, Refrigerating, and Air-Conditioning Engineers) handbook for details on proper piping sizes and design.
5. See product data for minimum system fluid volume. This system may require the addition of a holding tank to ensure adequate volume.
6. Hot gas lines should rise above refrigerant level in condenser circuit. With 30MPA/09DP matched condensers, this is accomplished internally in the 09DP unit. Double riser may be required; Check 30MPA line sizing chart.
7. Trap should be installed on hot gas lines to prevent condenser oil and refrigerant vapor migration from accumulating in the compressor during off cycle.
8. Pitch all horizontal lines downward in the direction of refrigerant flow.
9. For piping lengths greater than 50 ft (15 m), provide support to liquid and gas lines near the connections to the condenser coil.
10. For pressure relief requirements, see latest revision of ASHRAE Standard 15, Safety Code for Mechanical Refrigeration.
11. Operating environment — Chiller should be installed in an indoor environment where the ambient temperature is between 40 to 104°F (4 to 40°C) with a relative humidity (non-condensing) of 95% or less. To ensure that electrical components operate properly, do not locate the chiller in an area exposed to dust, dirt, corrosive fumes, or excessive heat and humidity.
12. Inverted trap required at condenser for 09DPM065-130.

Fig. 26 — Typical Piping and Wiring, 30MPA Unit with 09DP Remote Air-Cooled Condenser Shown

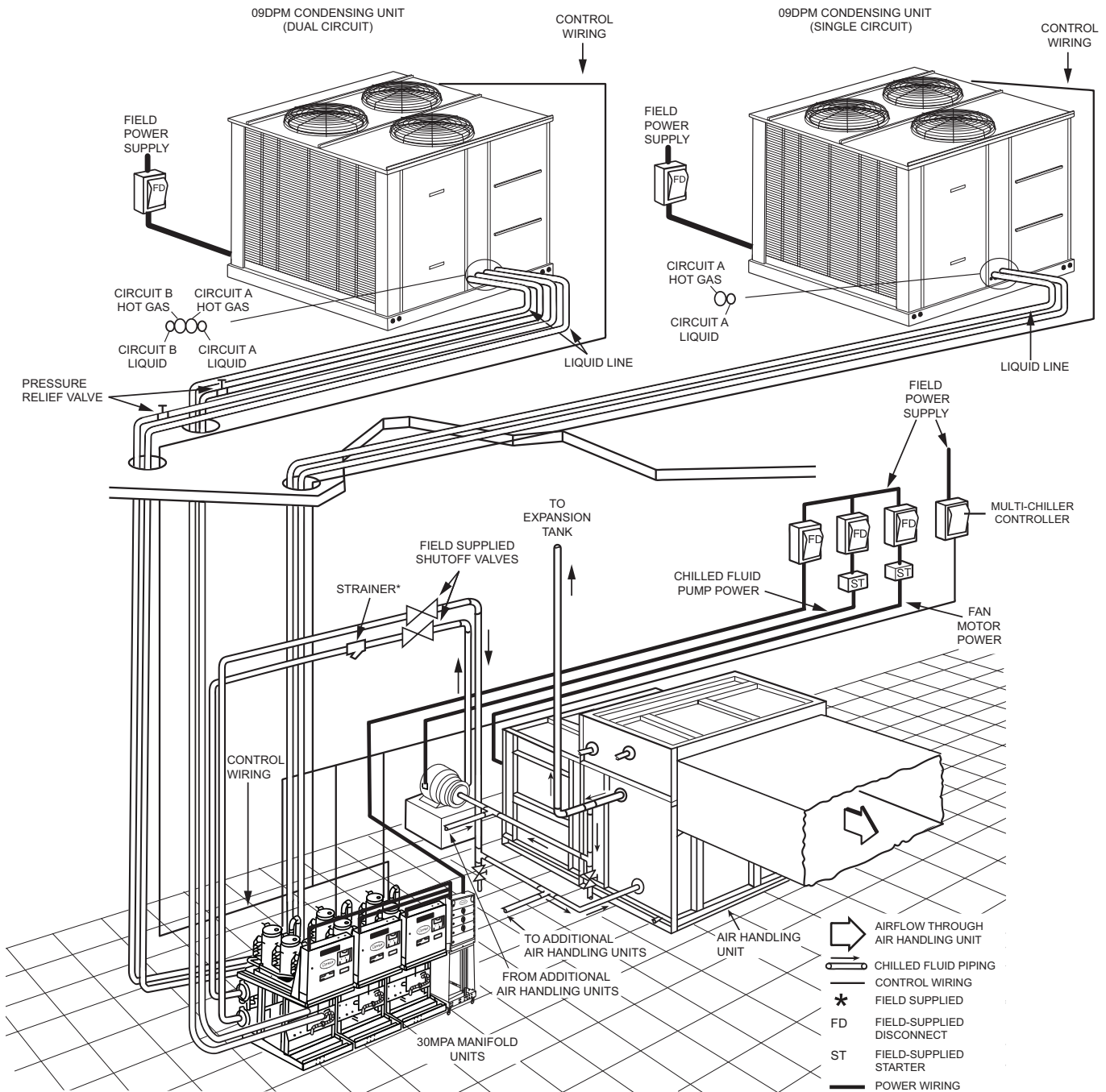

NOTES:

1. Chiller must be installed *levelly* to maintain proper compressor oil return (level adjustment kit included with manifold piping kit (option).
2. Wiring and piping shown are general points-of-connection guides only and are not intended for a specific installation. Wiring and piping shown are for a quick overview of system and are not in accordance with recognized standards.
3. All wiring must comply with applicable local and national codes.
4. All piping must follow standard piping techniques. Refer to Carrier System Design Manual part 3, Carrier E20-II software Refrigerant Piping program, or appropriate ASHRAE (American Society of Heating, Refrigerating, and Air-Conditioning Engineers) handbook for details on proper piping sizes and design.
5. See product data for minimum system fluid volume. This system may require the addition of a holding tank to ensure adequate volume.
6. Hot gas lines should rise above refrigerant level in condenser circuit. With 30MPA/09DP matched condensers, this is accomplished internally in the 09DP unit. Double riser may be required; Check 30MPA line sizing chart.
7. Trap should be installed on hot gas lines to prevent condenser oil and refrigerant vapor migration from accumulating in the compressor during off cycle.
8. Pitch all horizontal lines downward in the direction of refrigerant flow.
9. For piping lengths greater than 50 ft (15 m), provide support to liquid and gas lines near the connections to the condenser coil.
10. For pressure relief requirements, see latest revision of ASHRAE Standard 15, Safety Code for Mechanical Refrigeration.
11. Operating environment — Chiller should be installed in an indoor environment where the ambient temperature is between 40 to 104°F (4 to 40°C) with a relative humidity (non-condensing) of 95% or less. To ensure that electrical components operate properly, do not locate the chiller in an area exposed to dust, dirt, corrosive fumes, or excessive heat and humidity.
12. Inverted trap required at condenser for 09DPM065-130.

Fig. 27 —Typical Piping and Wiring, Manifold 30MPA Units with Dual Circuit 09DP Remote Air-Cooled Condenser Shown

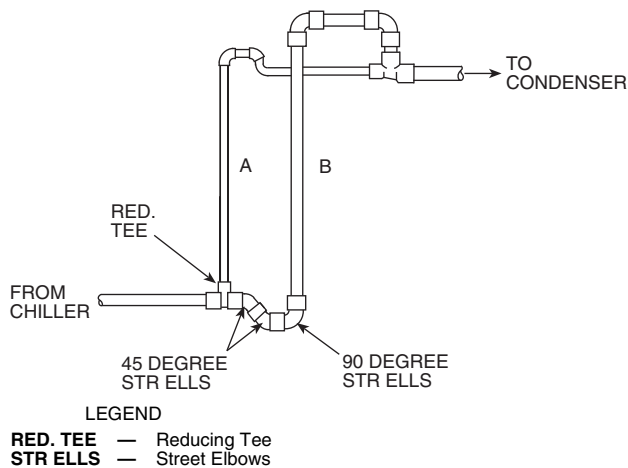

Fig. 28 — Double Discharge Riser Construction Detail

The 30MPA units that use air-cooled or evaporative condensers must have adequate means for head pressure control when operating below 65°F (18.3°C) ambient.

The 30MPA remote condenser requirements are as follows:

- If multiple units are connected to a single condenser, ensure each refrigerant circuit has its own head pressure control
- Condenser must provide 15°F (8.3°C) subcooling, maximum of 40°F (22.2°C) difference between saturated condensing temperature and outdoor ambient temperature (to prevent overload at high ambient temperatures), and a minimum of 20°F (11.1°C) difference (to ensure subcooling).
- Do not manifold multiple refrigerant circuits into a single condenser.
- If air-cooled condenser is located below chiller, refer to condenser manufacturer's performance data for available liquid lift.
- Refer to condenser installation instructions for location guidelines.

Carrier recommends that a field-supplied pressure relief device be installed in each discharge line of 30MPA units. Most local codes require the discharge line relief valve to be vented directly to the outdoors. The vent **must not** be smaller than the discharge line relief valve outlet.

The 30MPA units are shipped with a discharge line loop to facilitate factory testing. Relieve the pressure caused by the nitrogen holding charge. Cut the discharge line loop as close as possible to the elbow. This will leave approximately 2-in. (50 mm) of straight tubing for liquid line connection. Uncap the discharge line. Be sure to connect the discharge line to the larger line. Do not leave the reducing coupling in place.

- 30MPW UNITS WITH NITROGEN CHARGE — For 30MPW units with the factory nitrogen charge option, relieve the pressure caused by the nitrogen holding charge and proceed to the Evacuation and Dehydration section. It is best practice to minimize the amount of time the system is exposed to ambient air.

EVACUATION AND DEHYDRATION — Because the 30MP compressor oil can absorb moisture, it is important to minimize the amount of time that the system interior is

exposed to the atmosphere. Minimizing the exposure time of the oil to the atmosphere will minimize the amount of moisture that needs to be removed during evacuation.

Once all of the piping connections are complete, leak test the unit and then pull a deep dehydration vacuum. Connect the vacuum pump to the charging valve in the suction line and to the liquid line service valve. For best results, it is recommended that a vacuum of at least 500 microns (0.5 mm Hg) be obtained.

Afterwards, to ensure that no moisture is present in the system, perform a standing vacuum-rise test. With the unit in deep vacuum (500 microns or less), isolate the vacuum pump from the system. Observe the rate-of-rise of the vacuum in the system. If the vacuum rises by more than 50 microns in a 30-minute time period, continue the dehydration process. Maintain a vacuum on the system until the standing vacuum requirement is met. This will ensure a dry system.

By following these evacuation and dehydration procedures, the amount of moisture present in the system will be minimized.

30MPW CONDENSER DESCRIPTION — All 30MPW units use a brazed-plate heat-exchanger-type condenser. These heat exchangers are made of embossed plates of acid-resistant stainless steel. Every other plate is reversed so that the ridges of the herringbone pattern intersect one another on adjacent plates, forming a lattice of contact points. These plates are vacuum-brazed together to form a compact and pressure-resistant heat exchanger.

After brazing, the impressions in the plates form 2 separate systems of channels where the refrigerant and water flows are counterflow. The number of plates varies depending on unit capacity. The condensers provide approximately 10° to 12°F (6° to 8°C) liquid subcooling at the standard Air-Conditioning, Heating and Refrigeration Institute (AHRI) rating condition.

30MPW CONDENSER — When facing the unit control box, the condenser is the uninsulated heat exchanger located on the left-hand side. The water connections are on the right-hand side of the heat exchanger with the LIQUID-IN connection at the bottom, and the LIQUID-OUT connection at the top. For 30MPW units with water manifold option, refer to manifold Victaulic spacer fitting kit accessory installation instructions.

A strainer with a minimum of 40 mesh must be installed within 10 ft (3 m) of the chiller closest to the water header inlet to prevent debris from clogging or damaging the chiller's heat exchangers.

To install the Victaulic coupling (see Fig. 29):

1. Use Victaulic couplings designed for use on IPS dimensioned materials; for example, Style 75, Style 77, Quick Vic Style 107, or Style 177.
2. Lubricate the gasket lips and stretch the gasket over the end of the heat exchanger coupling. Avoid twisting the gasket when installing.
3. Bring the pipe and heat exchanger coupling ends together into alignment. Slide the gasket so that it is centered over the ends. Apply a light film of lubricant to the gasket, or to the outside diameter of the pipe. Avoid twisting the gasket during installation.
4. Install the inside coupling half over the gasket and then install the outer half. Connect with nuts and bolts. Tighten the nuts equally on both sides. Ensure there is no gap between the two halves of the coupling.

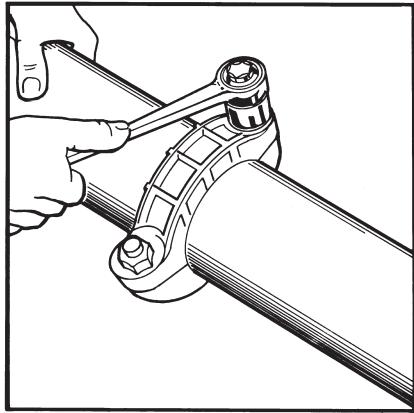

Fig. 29 — Install the Victaulic Coupling

- Alternately tighten the nuts with a wrench to draw the coupling halves together uniformly. The joint is now complete.

In order to minimize the water pressure drop in the system, use as few bends as possible in the field water piping, and run the lines as short as possible. Size the water lines according to the available pump pressure (not necessarily the connection size), especially on cooling tower applications. See Carrier System Design Manual, Part 3, Piping Design. See Fig. 30-33 for pressure drops.

CONDENSER WATER CONTROL VALVE — For installations where entering condenser water temperature could be below 65°F (18.3°C), a field-supplied control valve is required. Operation below 65°F (18.3°C) without a valve may result in nuisance low saturated suction alarms.

Set water regulating valve, if installed, to maintain design head pressure. Do not adjust to compensate for high head pressures caused by fouled condensers, excess refrigerant, or the presence of non-condensables. Due to changes in water temperature, it may be necessary to adjust the valve seasonally. After adjusting for design head pressure, shut unit down. The water regulating valve should shut off the flow of water in a few minutes. If it does not, raise head pressure setting. Make sure that the capillary tube from each water regulating valve is connected to the proper condenser access fitting.

Provide a means for draining the system in the winter (if not used) and for maintenance.

Water leaving the condenser is under pressure and should not be connected directly into sewer lines. Check local codes.

EVAPORATOR DESCRIPTION — All 30MP units use a brazed-plate heat-exchanger type evaporator. The heat exchanger is constructed essentially the same as the brazed-plate condenser used on 30MPW units. See 30MPW Condenser Description section on page 29 for more details. Similar to the condenser, the evaporator can only be chemically cleaned. See Fig. 30-33 for pressure drops.

EVAPORATOR PIPING — Plan evaporator fluid piping for minimum number of changes in elevation, and for the fewest number of bends possible. Install manual or automatic vent valve at high points in the line. Maintain system pressure by using a pressure tank or a combination of relief and reducing

valves. For units with water manifold option, refer to manifold Victaulic spacer fitting kit accessory installation instructions.

A strainer with a minimum of 40 mesh must be installed within 10 ft (3 m) of the chiller closest to the water header inlet to prevent debris from clogging or damaging the chiller's heat exchangers.

See Carrier System Design Manual, Part 3, Piping Design, for chilled fluid piping details.

The evaporator fluid inlet and outlet connections are Victaulic. The fluid enters at the top connection and leaves at the bottom connection. Procedures for making the connections are the same as for the 30MPW condensers. See 30MPW Condenser section on page 29 for more details.

Run the pump for 10 minutes, then clean the strainer before starting the unit.

An evaporator flow switch is standard on all units. This is a thermal dispersion type switch that is installed in evaporator fluid outlet. The switch is set to open when the evaporator fluid flow drops below the minimum set point.

For systems with glycol concentrations greater than 30%, it may be necessary to adjust the flow switch set point to avoid nuisance trips. Contact your Carrier representative for the method needed to adjust the switch.

See Table 8 for minimum flow rates. See Table 9 for minimum loop volume.

The thermistors used to sense entering and leaving fluid temperature are factory-installed in the evaporator entering and leaving fluid nozzles.

Table 8 — Minimum Evaporator and Condenser Flow Rates

UNIT SIZE	EVAPORATOR		CONDENSER	
	Gal./Min	L/s	Gal./Min	L/s
30MP016	22	1.4	22	1.4
30MP020	28	1.8	28	1.8
30MP030	43	2.7	43	2.7
30MP032	43	2.7	43	2.7
30MP040	55	3.5	55	3.5
30MP045	64	4.0	64	4.0
30MP050	70	4.5	70	4.5
30MP055	77	4.9	77	4.9
30MP060	84	5.4	84	5.4
30MP065	91	5.8	91	5.8
30MP071	104	6.7	104	6.7

Table 9 — Minimum Fluid Volume in Circulation

30MP UNIT SIZE	NORMAL AIR CONDITIONING APPLICATION gal/ton (L per kW)			PROCESS COOLING OR LOW AMBIENT OPERATION APPLICATION gal/ton (L per kW)		
	Std Unit	HGBP	Digital	Std Unit	HGBP	Digital
	016 020,030 032	6 (6.5)	4 (4.3)	3 (3.3)	10 (10.8)	10 (10.8)
040,045	3 (3.3)	3 (3.3)	3 (3.3)	6 (6.5)	6 (6.5)	6 (6.5)
050-071	6 (6.5)	4 (4.3)	—	10 (10.8)	10 (10.8)	—

LEGEND

HGBP — Hot Gas Bypass

ENGLISH

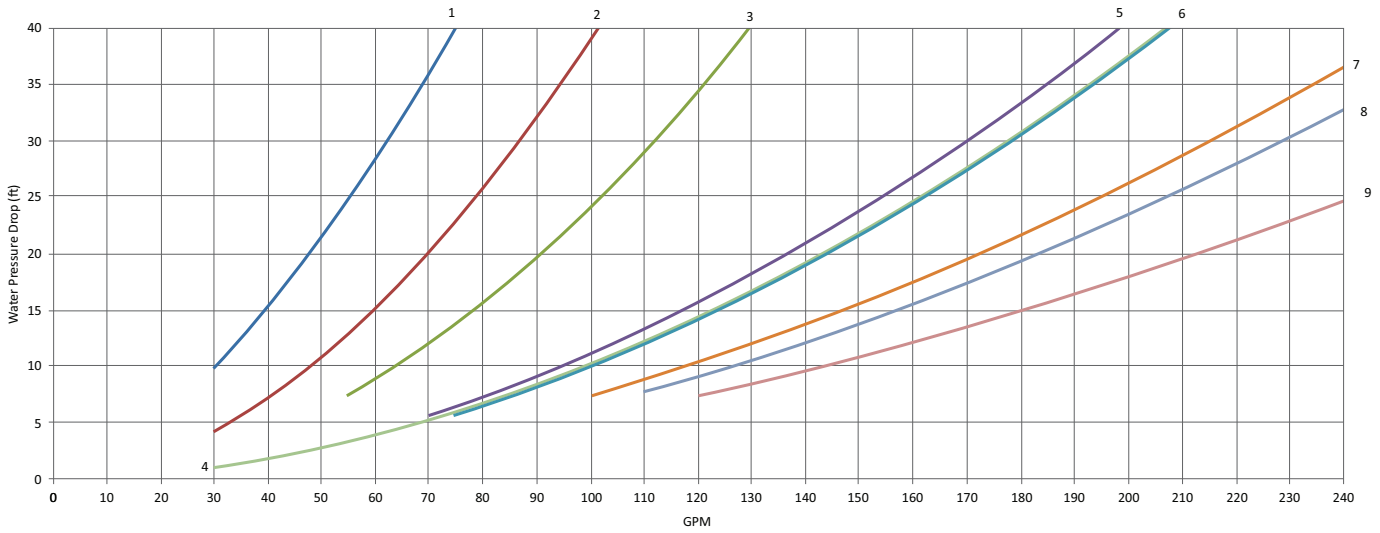

SI

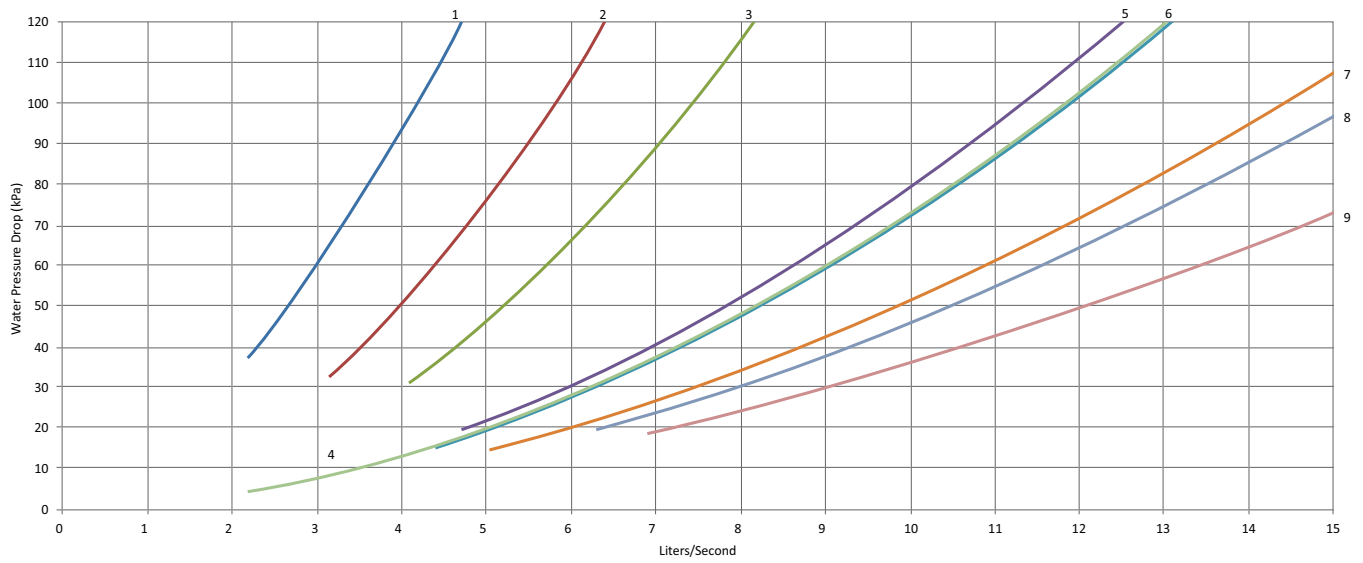

LEGEND

- | | |
|-------------|-----------------|
| 1 — 30MP016 | 6 — 30MP045 |
| 2 — 30MP020 | 7 — 30MP050,055 |
| 3 — 30MP030 | 8 — 30MP060,065 |
| 4 — 30MP032 | 9 — 30MP071 |
| 5 — 30MP040 | |

NOTE: Pressure drop curves assume water temperature of 68°F (20°C).

Fig. 30 — Evaporator Pressure Drop Curve, Standard Units

ENGLISH

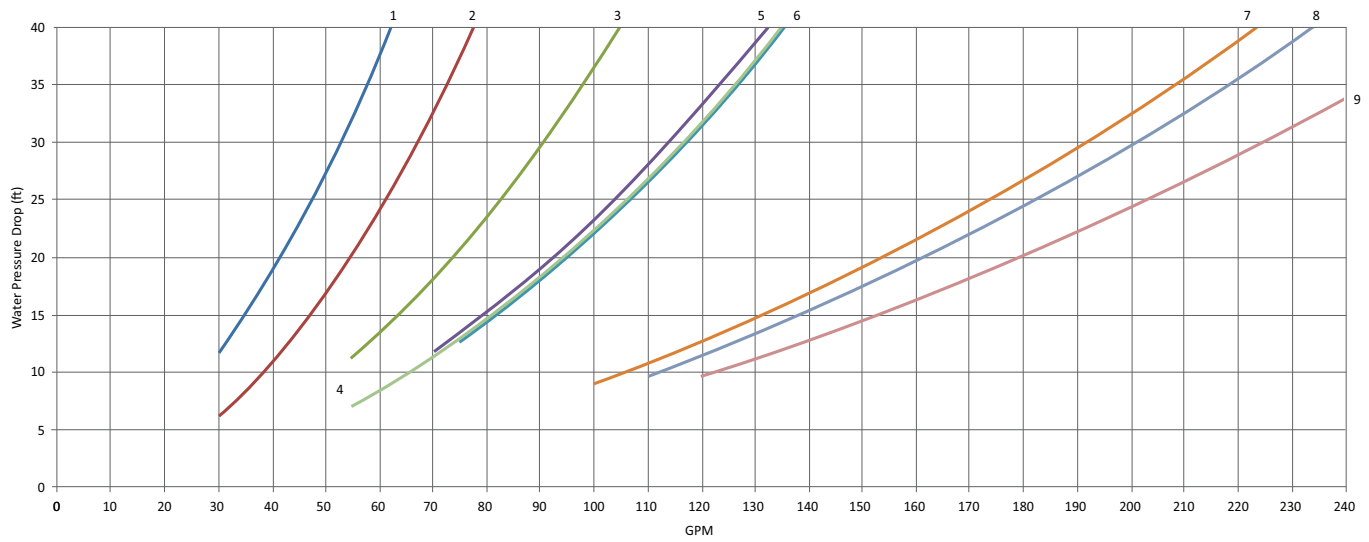

SI

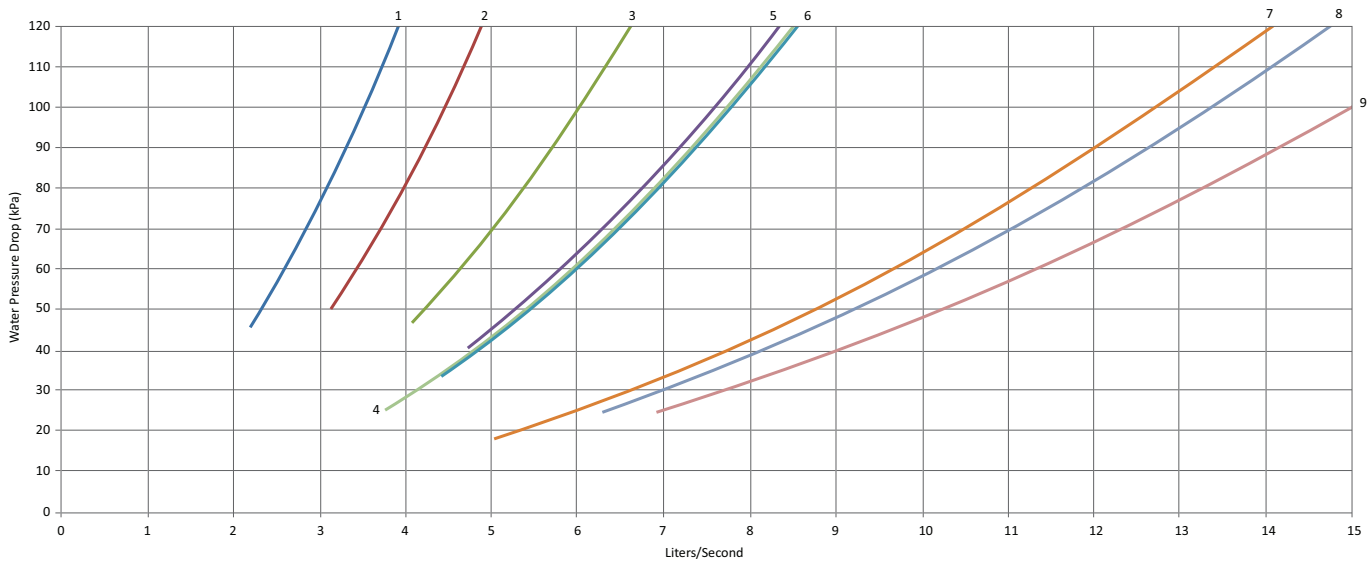

LEGEND

- | | |
|-------------|-----------------|
| 1 — 30MP016 | 6 — 30MP045 |
| 2 — 30MP020 | 7 — 30MP050,055 |
| 3 — 30MP030 | 8 — 30MP060,065 |
| 4 — 30MP032 | 9 — 30MP071 |
| 5 — 30MP040 | |

NOTE: Pressure drop curves assume water temperature of 68°F (20°C).

Fig. 31 — Evaporator Pressure Drop Curve, Style B* Manifold Units

ENGLISH

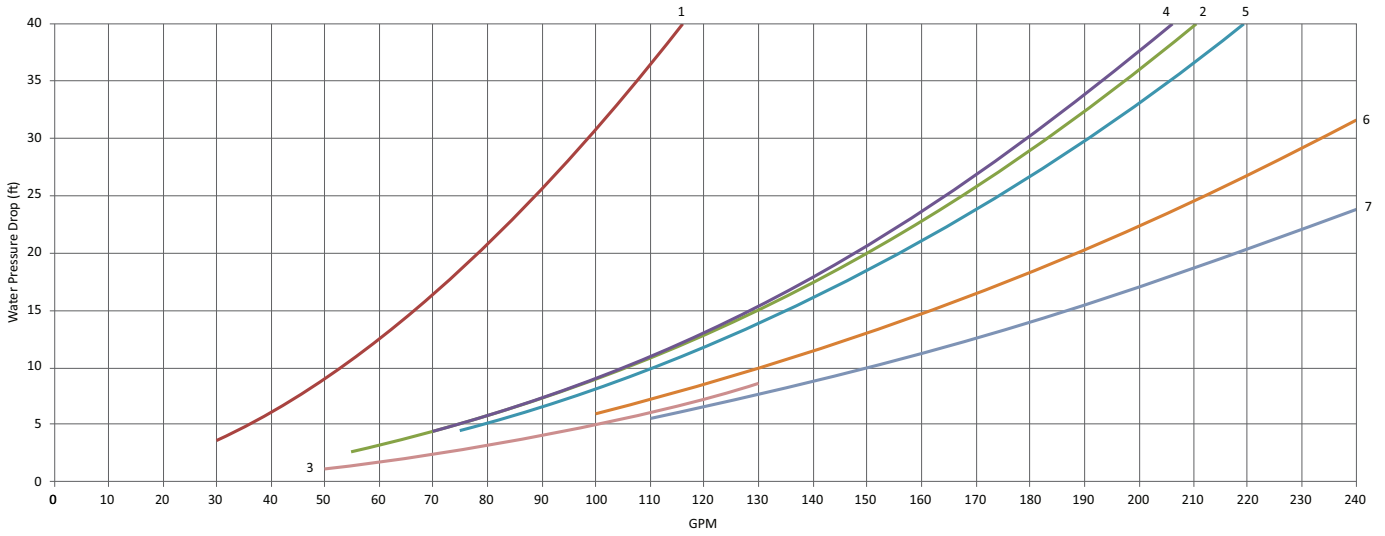

SI

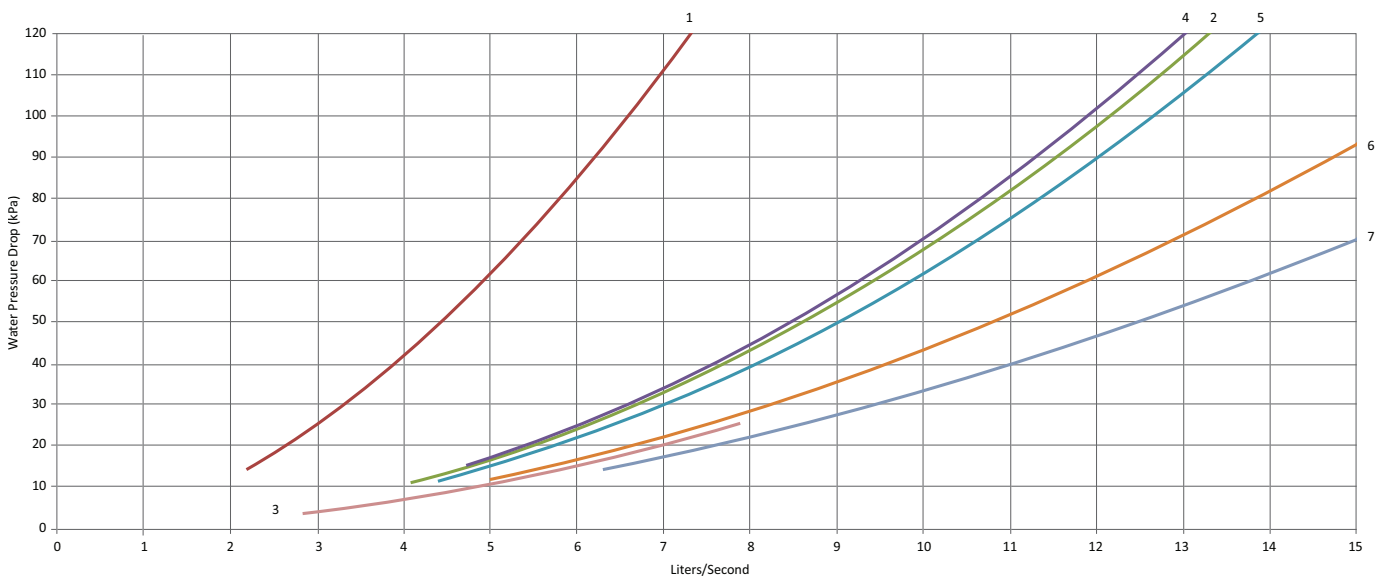

LEGEND

- | | |
|-----------------|-----------------------|
| 1 — 30MP016/020 | 5 — 30MP045 |
| 2 — 30MP030 | 6 — 30MP050, 55 |
| 3 — 30MP032 | 7 — 30MP060, 065, 071 |
| 4 — 30MP040 | |

NOTE: Pressure drop curves assume water temperature of 68°F (20°C).

Fig. 32 — Condenser Pressure Drop Curve, Standard Units

ENGLISH

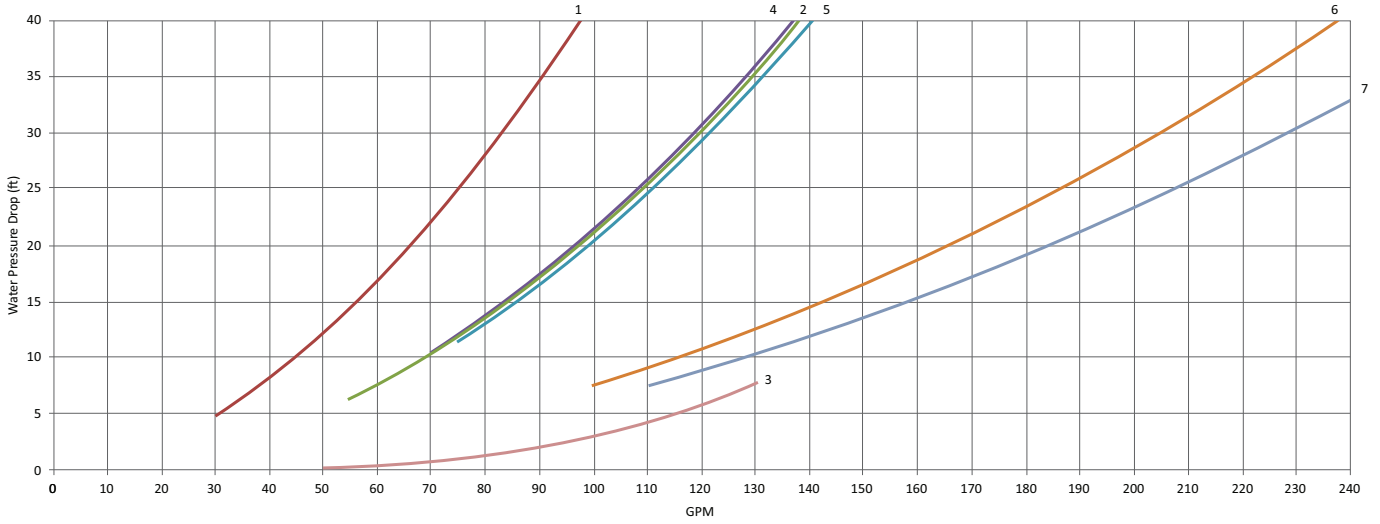

SI

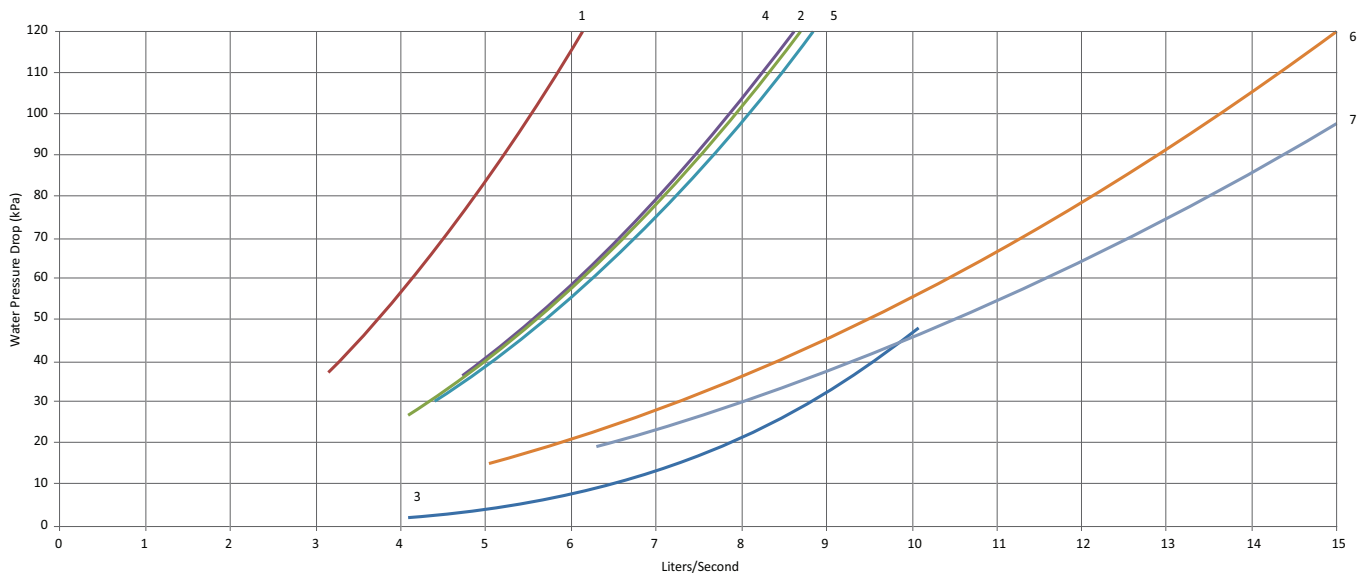

LEGEND

- | | |
|-----------------|-----------------------|
| 1 — 30MP016/020 | 5 — 30MP045 |
| 2 — 30MP030 | 6 — 30MP050, 55 |
| 3 — 30MP032 | 7 — 30MP060, 065, 071 |
| 4 — 30MP040 | |

NOTE: Pressure drop curves assume water temperature of 68°F (20°C).

Fig. 33 — Condenser Pressure Drop Curve, Style B* Manifold Units

FOR UNITS WITH WATER MANIFOLD — The water manifold is a factory-installed option, however the option comes with the leveling kit which must be field-installed. See leveling kit installation instructions.

For 30MP chillers, water valves are included on each water in and out line between the 6 in. manifold and the heat exchanger. These valves can be used for calibration or isolation for service.

⚠ WARNING

It is not recommended to use the water valves for dead end service. If the heat exchanger is removed, it is best to install a Victaulic fitting and end cap on the open end of the valve. Failure to follow these instructions could result in serious personal injury and property damage.

DUAL CHILLER CONTROL OPTION — If the dual chiller algorithm is used, the machines must be installed in parallel. An additional sensor (DUAL) must be installed in the common water line and connected to the master chiller. See Fig. 34 for typical piping. The units must also be connected via communications. See the Controls and Troubleshooting book for communication connection information.

MULTI-UNIT CHILLER CONTROL ACCESSORY — If the multi-unit chiller control accessory is used, the machines must be installed in parallel (see Fig. 35). The accessory kit contains the necessary chilled water temperature sensor, which must be installed in a common water line; and connected to the controller accessory. All chillers must be equipped with the BACnet¹ communication option and must be connected to the controller accessory on an MS/TP network segment in a daisy chain configuration. See the Multi-Unit Controller Accessory Installation Instruction for further information.

AIR SEPARATION — For proper system operation, it is essential that water loops be installed with proper means to

1. BACnet is a registered trademark of ASHRAE (American Society of Heating, Refrigerating, and Air-Conditioning Engineers).

manage air in the system. Free air in the system can cause noise, reduce terminal output, stop flow, or even cause pump failure due to pump cavitation. For closed systems, equipment should be provided to eliminate all air from the system.

The amount of air that water can hold in solution depends on the pressure and temperature of the water/air mixture. Air is less soluble at higher temperatures and at lower pressures. Therefore, separation can best be done at the point of highest water temperature and lowest pressure. Typically, this point would be on the suction side of the pump as the water is returning from the system or terminals. Generally speaking, this is the best place to install an air separator, if possible.

1. Install automatic air vents at all high points in the system. (If the 30MP unit is located at the high point of the system, a vent can be installed on the piping entering the heat exchanger on the 1/4-in. NPT female port.)
2. Install an air separator in the water loop, at the place where the water is at higher temperatures and lower pressures — usually in the chilled water return piping. On a primary-secondary system, the highest temperature water is normally in the secondary loop, close to the decoupler. Preference should be given to that point on the system (see Fig. 36). In-line or centrifugal air separators are readily available in the field.

It may not be possible to install air separators at the place of lowest pressure and highest temperature. In such cases, preference should be given to the points of highest temperature. It is important that pipe be sized correctly so that free air can be moved to the point of separation. Generally, a water velocity of at least 2 feet per second will keep free air entrained and prevent it from forming air pockets.

Automatic vents should be installed at all physically elevated points in the system so that air can be eliminated during system operation. Provision should also be made for manual venting during the water loop fill. It is important that the automatic vents be located in accessible locations for maintenance purposes, and that they be located where they can be prevented from freezing.

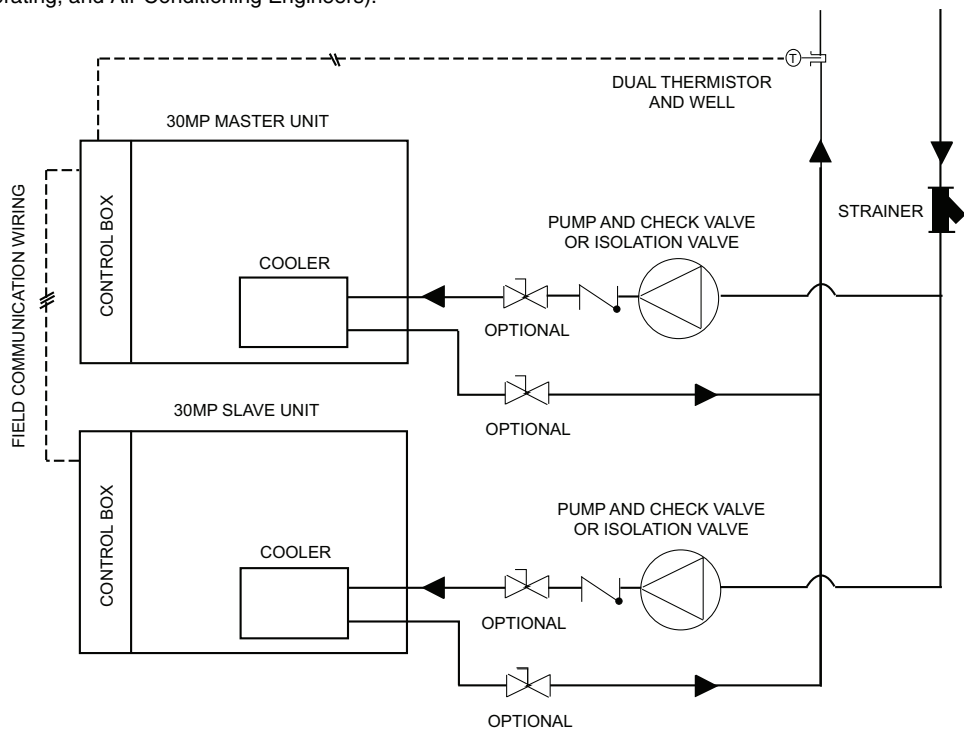

NOTE: This is a simplified piping diagram, not all hydronic specialties are shown.

Fig. 34 — Dual Chiller Control Option Typical Piping

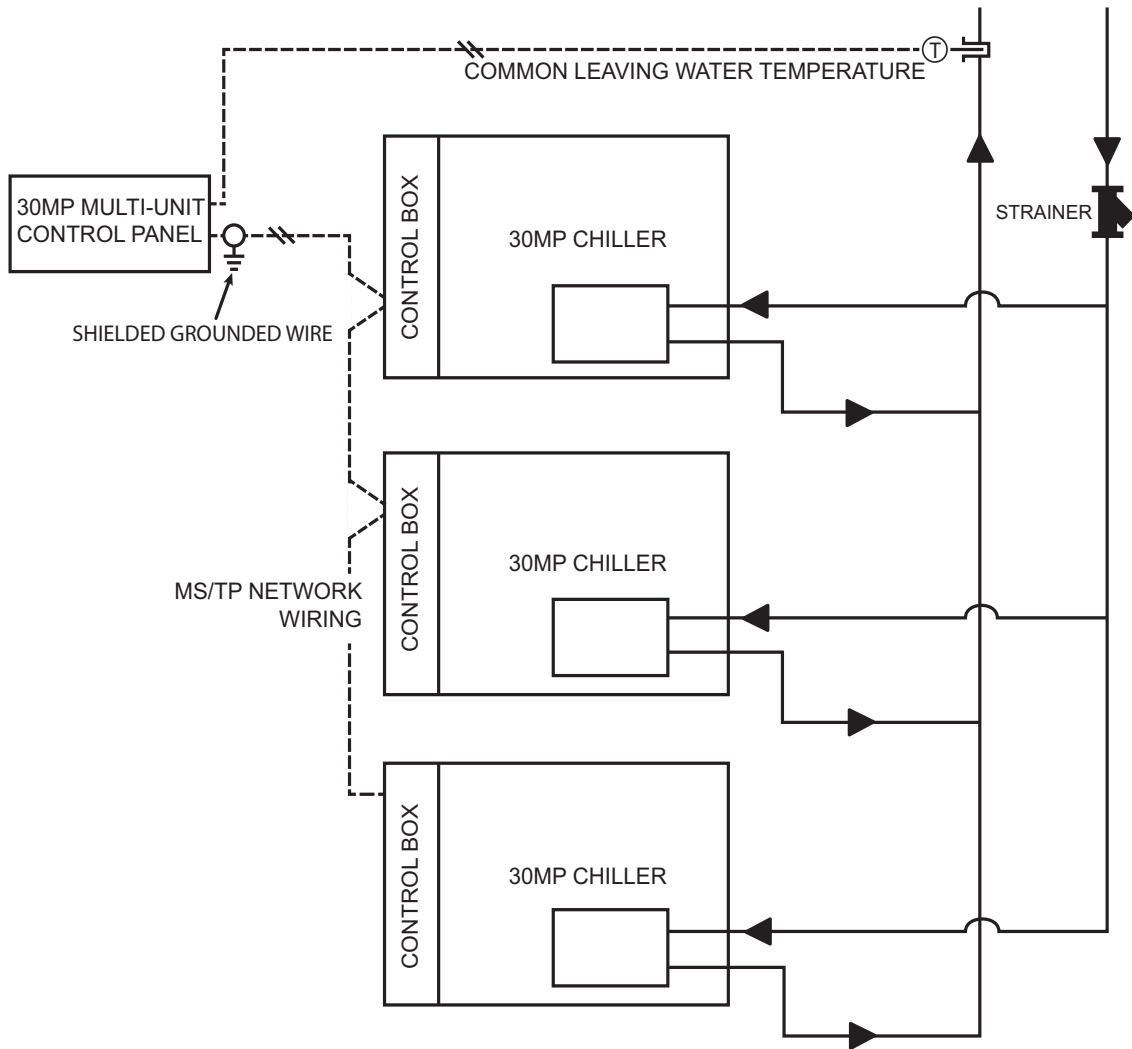

Fig. 35 — Multi-Unit Control Panel Option

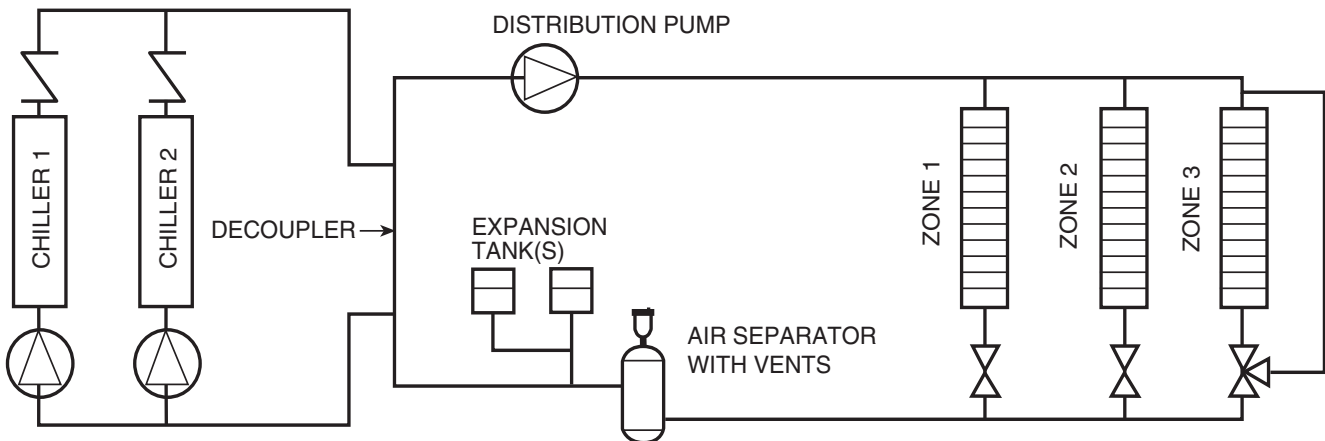

Fig. 36 — Typical Air Separator and Expansion Tank Location on Primary-Secondary Systems

Step 6 — Fill the Chilled Water Loop

WATER SYSTEM CLEANING — Proper water system cleaning is of vital importance. Excessive particulates in the water system can cause excessive pump seal wear, reduce or stop flow, and cause damage of other components. Water quality should be maintained within the limits indicated in Table 10. Failure to maintain proper water quality may result in heat exchanger failure.

⚠ CAUTION

Failure to properly clean all piping and components of the chilled water system before unit start-up may result in plugging of the heat exchanger, which can lead to poor performance, nuisance alarms and damage from freezing. Freezing damage caused by an improperly cleaned system represents abuse and may impair or otherwise negatively affect the Carrier product warranty.

Table 10 — Water Quality Characteristics and Limitations

WATER CHARACTERISTIC	QUALITY LIMITATION
Alkalinity (HCO ₃ ⁻)	70 – 300 ppm
Sulfate (SO ₄ ²⁻)	Less than 70 ppm
HCO ₃ ⁻ /SO ₄ ²⁻	Greater than 1.0
Electrical Conductivity	10 – 500 µS/cm
pH	7.5 – 9.0
Ammonia (NH ₃)	Less than 2 ppm
Chlorides (Cl ⁻)	Less than 300 ppm
Free chlorine (Cl ₂)	Less than 1 ppm
Hydrogen Sulfide (H ₂ S)*	Less than 0.05 ppm
Free (aggressive) Carbon Dioxide (CO ₂)†	Less than 5 ppm
Total Hardness (°dH)	4.0 – 8.5
Nitrate (NO ₃)	Less than 100 ppm
Iron (Fe)	Less than 0.2 ppm
Aluminum (Al)	Less than 0.2 ppm
Manganese (Mn)	Less than 0.1 ppm

*Sulfides in the water quickly oxidize when exposed to air, requiring that no agitation occur as the sample is taken. Unless tested immediately at the site, the sample will require stabilization with a few drops of one Molar zinc acetate solution, allowing accurate sulfide determination up to 24 hours after sampling. A low pH and high alkalinity cause system problems, even when both values are within the ranges shown. The term pH refers to the acidity, basicity, or neutrality of the water supply. Below 7.0, the water is considered to be acidic. Above 7.0, water is considered to be basic. Neutral water has a pH of 7.0.

†Dissolved carbon dioxide can either be calculated from the pH and total alkalinity values, shown below, or measured on the site using a test kit. Dissolved Carbon Dioxide, PPM = $TA \times 2^{(6.3-pH)/0.3}$ where TA = Total Alkalinity, PPM as CaCO₃.

To perform proper water system cleaning perform the following steps:

1. Install a temporary bypass around the chiller to avoid circulating dirty water and particulates into the pump package and chiller during the flush. Use a temporary circulating pump during the cleaning process. Also, be sure that there is capability to fully drain the system after cleaning (see Fig 37).
2. Be sure to use a cleaning agent that is compatible with all system materials. Be especially careful if the system contains any galvanized or aluminum components. Both detergent-dispersant and alkaline-dispersant cleaning agents are available.
3. It is a good idea to fill the system through a water meter. This provides a reference point for the future for loop volume readings, but it also establishes the correct quantity of cleaner needed in order to get the required concentration.
4. Use a feeder/transfer pump to mix the solution and fill the system. Circulate the cleaning system for the length of time recommended by the cleaning agent manufacturer.

- a. After cleaning, drain the cleaning fluid and flush the system with fresh water.
- b. A slight amount of cleaning residue in the system can help keep the desired, slightly alkaline, water pH of 8 to 9. Avoid a pH greater than 10, since this will adversely affect pump seal components.
- c. A side stream filter is recommended (see Fig. 38) during the cleaning process. Filter side flow rate should be enough to filter the entire water volume every 3 to 4 hours. Change filters as often as necessary during the cleaning process.
- d. Remove temporary bypass when cleaning is complete.

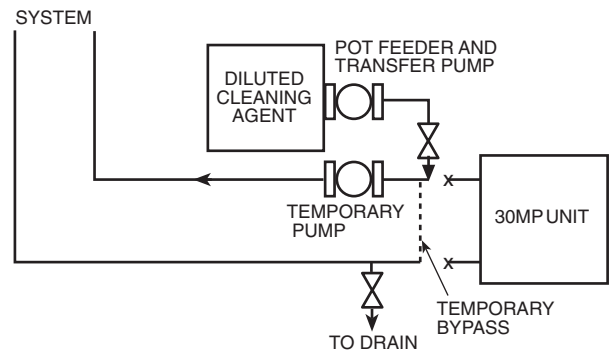

Fig. 37 — Typical Set Up for Cleaning Process

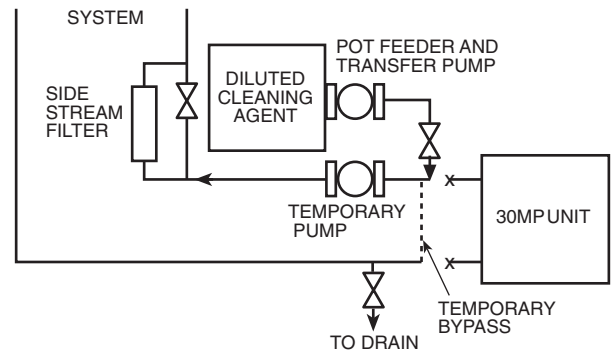

Fig. 38 — Cleaning Using a Side Stream Filter

FILLING THE SYSTEM — The initial fill of the chilled water system must accomplish three purposes:

1. The entire piping system must be filled with water.
2. The pressure at the top of the system must be high enough to vent air from the system (4 psig is usually adequate for most vents).
3. The pressure at all points in the system must be high enough to prevent flashing in the piping or cavitation in the pump.

The pressure created by an operating pump affects system pressure at all points except one, the connection of the compression tank to the system. This is the only location in the system where pump operation will not give erroneous pressure indications during the fill. Therefore, the best location to install the fill connection is close to the expansion tank. An air vent should be installed close by to help eliminate air that enters during the fill procedure.

Ensure the following when filling the system:

1. Remove temporary bypass piping and cleaning/flushing equipment.
2. Check to make sure all drain plugs are installed.
3. Open the blow-down valve to flush the strainer.

Normally, a closed system needs to be filled only once. The actual filling process is generally a fairly simple procedure. All air should be purged or vented from the system. Thorough venting at the high points and circulation at room temperature for several hours is recommended.

NOTE: Local codes concerning backflow devices and other protection of the city water system should be consulted and followed to prevent contamination of the public water supply. This is especially important when antifreeze is used in the system.

Set Water Flow Rate through the chiller once the system is cleaned, pressurized, and filled.

NOTE: Carrier recommends a differential pressure gage when measuring pressures across the pumps or balancing valves. This provides for greater accuracy and reduces error build-up that often occurs when subtracting pressures made by different gages.

On primary/secondary systems, it is advisable to set the 30MP balancing valve to maintain design flow plus 10% through the chiller.

A rough estimate of water flow can also be obtained from measuring the pressure drop across the 30MP heat exchanger. Figures 30-33 show the relationship between gpm (l/s) and heat exchanger pressure drop. It should be noted that these curves are for “clean” heat exchangers with fresh water; they do not apply to heat exchangers with fouling or glycol. Adjust the external balancing valve until the correct pressure drop is obtained for the required gpm.

Step 7 — Make Electrical Connections — All field wiring must comply with local code requirements. Electrical data for the complete unit and for the compressors is shown in Tables 11-13. See Fig. 39 for field wiring connections. A field-supplied branch circuit disconnect switch that can be locked in either OPEN or OFF position **must** be installed.

⚠ CAUTION

Failure to follow these instructions may result in unit damage. When wiring the 30MP chiller to its associated 30MPE distribution panel, it is important to connect each chiller to its corresponding circuit breaker in the panel.

Each circuit breaker has been sized for its particular chiller. Proper installation is critical to ensure appropriate wire sizing, hazard avoidance, and compliance with local code(s). Consult submittal information.

30MPA, MPW CONTROL BOX

30MPA, MPW Controls Section contains the following components:

- main base board (MBB)
- scrolling marquee display
- optional energy management module
- control-circuit breakers for 24-v circuits
- control-circuit ON-OFF switch
- unit Enable/Off/Remote contact switch
- unit Alarm/Alert indicator light

30MPA, MPW Control Wiring (Factory-Wired) circuit power is 24 v on all units. Factory-installed control transformer (TRAN 1) uses line voltage for all units. All control transformers are factory-installed and wired. For 208/230-3-60 units operating at 208-3-60 line voltage, TRAN1 primary connections

must be moved to terminals H3 and H4 for 30MP016-045 units, or terminals H1 and H2 for 30MP050-071 units.

Inside the control box are terminals for field power and ground (earth) wiring. A ground wire must be installed with each field power supply. Compressors are wired for across-the-line start. Refer to Tables 11-13 for electrical data.

30MPA, MPW, Control Wiring (Field-Wired) is found in the 30MPA, MPW control box which contains the low-voltage, field-wiring terminal strip (LVT). All low-voltage field-wiring connections are made to this terminal block, see Fig. 39. Three 7/8-in. (22 mm) knockouts are provided for field wiring in this section.

Connections for condenser flow switch, chilled fluid pump interlock, condenser pump interlock, remote alarm output, condenser output, and dual chiller thermistor accessory are made at these locations. Connections for the multi-unit controller accessory network are made to the BACnet communication module.

The unit has the capability to control field-supplied devices. They are: alarm signal, condenser pump or condenser fan output, and chilled water pump output. The unit provides 24-v power with a maximum 5 va rating per output allowed.

30MPA, MPW Power Section supplies power to the 30MPA, MPW unit. The electrical power supply is brought in through the top left-hand side of the control box. Pressure-lug connections on the terminal blocks are suitable for only for copper conductors.

The control box power section contains the following components:

- power terminal block
- optional disconnect switch
- compressor circuit breaker(s)
- compressor contactor(s)
- current sensor boards
- control transformer
- ground lug
- neutral terminal (380-3-60, 380/415-3-50 units only)
- crankcase heater relay (30MPA, all units, 30MPW030 - 071)
- fuses

Flow Switches are provided on all units to provide a cooler flow and are factory-installed and wired. A condenser flow switch is available as an accessory for all 30MPW units, and can be field-installed. The Carrier flow switch accessory (part no. 30MP-900--004) is available for this purpose. Flow switch wiring terminals are located in the field wiring compartment of the control box. The flow switch should be wired between terminals LVT-11 and LVT-17 for all units. Condenser water flow switch cannot be used if a condenser water regulating valve is installed.

30MPE DISTRIBUTION PANEL — Inside the panel are terminals for field power and ground (earth) wiring. A ground connection is available, and must be connected, in the 30MPE panel for each chiller.

30MPE Distribution Panel, Power Section provides power to the 30MPE distribution panel. The electrical power supply is brought in through the top of the 30MPE distribution panel. Pressure-lug connections on the terminal blocks or bus bar are suitable for copper conductors only. The distribution panel power section contains the following components:

- power terminal blocks or bus bar
- circuit breakers
- ground lugs

UNBALANCED 3-PHASE SUPPLY VOLTAGE —
 Use the following formula to determine the percent voltage imbalance:

% Voltage Imbalance =

$$100 \times \frac{\text{max voltage deviation from average voltage}}{\text{average voltage}}$$

EXAMPLE: Supply voltage is 240-3-60.

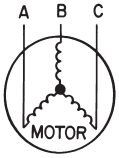

AB = 243 v

BC = 236 v

AC = 238 v

$$\begin{aligned} \text{Average Voltage} &= \frac{243 + 236 + 238}{3} \\ &= 239 \text{ v} \end{aligned}$$

Determine maximum deviation from average voltage:

(AB) $243 - 239 = 4 \text{ v}$

(BC) $239 - 236 = 3 \text{ v}$

(AC) $239 - 238 = 1 \text{ v}$

Maximum deviation is 4 v.

Determine percent voltage imbalance:

$$\begin{aligned} \% \text{ Voltage Imbalance} &= 100 \times \frac{4}{239} \\ &= 1.7\% \end{aligned}$$

This amount of phase imbalance is satisfactory as it is below the maximum allowable 2%.

IMPORTANT: If the supply voltage phase imbalance is more than 2%, contact your local utility company immediately.

Table 11 —30MPA,MPW016-045 UNITS

UNIT SIZE 30MPA, MPW	VOLTS NAMEPLATE	VOLTAGE		COMPRESSOR A1		COMPRESSOR A2		COMPRESSOR A3		UNIT			
		MIN	MAX	RLA (EA)	LRA (EA)	RLA (EA)	LRA (EA)	RLA (EA)	LRA (EA)	MCA	ICF	MOCP	REC FUSE
016	208/230-3-60	187	253	24.8	240.0	17.2	164	N/A	N/A	48.2	257.2	70	60
	380-3-60	342	418	16.0	134.0	12.2	73			32.2	146.2	45	40
	460-3-60	414	508	12.4	130.0	8.6	75			24.1	138.6	35	30
	575-3-60	518	632	10.0	93.7	7.0	54			19.5	100.7	25	25
	380/415-3-50	342	440	12.4	130.0	8.6	75			24.1	138.6	35	30
020	208/230-3-60	187	253	35.8	239.0	35.8	239	N/A	N/A	80.6	274.8	110	90
	380-3-60	342	418	23.7	145.0	23.7	145			53.4	168.7	70	60
	460-3-60	414	508	17.9	125.0	17.9	125			40.3	142.9	50	45
	575-3-60	518	632	14.3	80.0	14.3	80			32.2	94.3	45	40
	380/415-3-50	342	440	20.0	118.0	20.0	118			45.0	138.0	60	60
030	208/230-3-60	187	253	55.8	340.0	55.8	340	N/A	N/A	125.6	395.8	175	150
	380-3-60	342	418	34.0	196.0	34.0	196			76.5	230.0	110	90
	460-3-60	414	508	26.9	179.0	26.9	179			60.5	205.9	80	70
	575-3-60	518	632	23.7	132.0	23.7	132			53.3	155.7	70	60
	380/415-3-50	342	440	28.6	174.0	28.6	174			64.3	202.6	90	80
040	208/230-3-60	187	253	51.3	300.0	51.3	300	51.3	300	166.7	402.6	200	200
	380-3-60	342	418	26.9	139.0	26.9	139	26.9	139	87.4	192.8	110	100
	460-3-60	414	508	23.1	150.0	23.1	150	23.1	150	75.1	196.2	90	90
	575-3-60	518	632	19.9	109.0	19.9	109	19.9	109	64.7	148.8	80	70
	380/415-3-50	342	440	25.0	140.0	25.0	140	25.0	140	81.3	190.0	100	90
045	208/230-3-60	187	253	55.8	340.0	55.8	340	55.8	340	181.4	451.6	225	200
	380-3-60	342	418	34.0	196.0	34.0	196	34.0	196	110.5	264.0	125	125
	460-3-60	414	508	26.9	179.0	26.9	179	26.9	179	87.4	232.8	110	100
	575-3-60	518	632	23.7	132.0	23.7	132	23.7	132	77.0	179.4	100	90
	380/415-3-50	342	440	28.6	174.0	28.6	174	28.6	174	92.9	231.1	110	110
UNIT SIZE 30MPW	VOLTS NAMEPLATE	VOLTAGE		COMPRESSOR A1		COMPRESSOR B1		COMPRESSOR (A/B)2		UNIT			
		MIN	MAX	RLA (EA)	LRA (EA)	RLA (EA)	LRA (EA)	RLA (EA)	LRA (EA)	MCA	ICF	MOCP	REC FUSE
032	208/230-3-60	187	253	42.0	340	42.0	340	N/A	N/A	94.5	382.0	125	110
	460-3-60	414	508	21.0	179	21.0	179			47.3	200.0	60	60
	575-3-60	518	632	17.0	132	17.0	132			38.3	149.0	50	45

LEGEND

- AWG** — American Wire Gage
- ICF** — Maximum instantaneous current flow during starting
- kcmil** — Thousand circular mils
- LRA** — Locked Rotor Amps
- MCA** — Minimum Circuit Amps (for wire sizing). Complies with NEC, Section 430-24.
- MOCP** — Maximum Overcurrent Protection
- Rec Fuse** — Recommended dual element fuse amps (150% of compressor RLA). Size up to the next standard fuse size.
- RLA** — Rated Load Amps

*Supply Range — Units are suitable for use on electrical systems where voltage supplied to the unit terminals is not below or above the listed range limits.

NOTES:

1. All units have one field power terminal block.
2. Maximum incoming wire size is as follows:
For units with terminal block:
 350 kcmil for unit sizes 030-045;
 208/230-3-60 voltages.
 2/0 for unit sizes 016-045; all other voltages.
For units with optional non-fused disconnect:
 350 kcmil for unit sizes:
 030-045; 208/230-3-60 voltages.
 045; 380-3-60 voltage.
 3/0 AWG for unit sizes:
 016,020; 208/230-3-60 voltages.
 020-040; 380-3-60 voltage.
 030-045; 460-3-60, 380/415-3-50 and 575-3-60 voltages.
 2 AWG for unit sizes:
 016; 380-3-60 voltage.
 016,020; 460-3-60, 380/415-3-50 and 575-3-60 voltages.
For units with optional fused disconnect:
 6 AWG to 10 AWG for all voltages.
3. Additional control circuit power is not required.

4. Any field modification of factory wiring must be in compliance with all applicable codes. Field-installed power wires must be rated 75°C minimum.
5. Use copper conductors only.
6. Control circuit power supply is 24-v single phase. Control power is supplied by the factory-installed control transformer.
7. The MOCP of the electrical distribution panel is calculated as follows:

First, calculate the MOCP of each individual chiller. MOCP = 2.25 (Largest RLA) + Sum of the other RLAs. Sum the MOCPs of each individual chiller. This is the MOCP of the electrical distribution panel associated with this bank of chillers. Select the next size down fuse from this value.

The recommended fuse size in amps (RFA) is calculated as follows: RFA = 1.50* (largest RLA) + (Smallest RLA) for the given bank of chillers.

8. The MCA of the electrical distribution panel is calculated as follows:

First, calculate the MCA of each individual chiller. MCA = 1.25 (Largest RLA) + sum of the other RLAs. Sum the MCAs of each individual chiller. This is the MCA of the electrical distribution panel associated with this bank of chillers.



Intertek

Table 12 — Electrical Data — 30MPA,MPW050-071 Units with High Condensing Option

UNIT SIZE 30MPA, MPW	VOLTS NAMEPLATE	VOLTAGE*		COMPRESSOR A1		COMPRESSOR A2		UNIT			
		MIN	MAX	RLA	LRA	RLA	LRA	MCA	ICF	MOCP	REC FUSE
050	208/230-3-60	187	253	85.1	436	85.1	436	191.5	521.1	250	225
	380-3-60	342	418	49.3	252	49.3	252	110.9	301.3	150	125
	460-3-60	414	508	40.7	212	40.7	212	91.6	252.7	125	110
	575-3-60	518	632	32.6	168	32.6	168	73.4	200.6	100	90
	380/415-3-50	342	440	40.7	212	40.7	212	91.6	252.7	125	110
055	208/230-3-60	187	253	85.1	436	106.2	578	217.9	663.1	300	250
	380-3-60	342	418	49.3	252	64.3	355	129.7	404.3	175	150
	460-3-60	414	508	40.7	212	53.1	290	107.1	330.7	150	125
	575-3-60	518	632	32.6	168	42.5	255	85.7	287.6	125	100
	380/415-3-50	342	440	40.7	212	53.1	290	107.1	330.7	150	125
060	208/230-3-60	187	253	85.1	436	102.8	635	213.6	720.1	300	250
	380-3-60	342	418	49.3	252	62.2	355	127.1	404.3	175	150
	460-3-60	414	508	40.7	212	51.4	280	105.0	320.7	150	125
	575-3-60	518	632	32.6	168	41.1	225	84.0	257.6	125	100
	380/415-3-50	342	440	40.7	212	51.4	280	105.0	320.7	150	125
065	208/230-3-60	187	253	85.1	436	128.2	602	245.4	687.1	350	300
	380-3-60	342	418	49.3	252	77.6	367	146.3	416.3	200	175
	460-3-60	414	508	40.7	212	64.1	298	120.8	338.7	175	150
	575-3-60	518	632	32.6	168	51.3	229	96.7	261.6	125	110
	380/415-3-50	342	440	40.7	212	64.1	298	120.8	338.7	175	150
071	208/230-3-60	187	253	106.2	578	128.2	602	266.5	708.2	350	300
	380-3-60	342	418	64.3	355	77.6	367	161.3	431.3	225	200
	460-3-60	414	508	53.1	290	64.1	298	133.2	351.1	175	150
	575-3-60	518	632	42.5	255	51.3	229	106.6	297.5	150	125
	380/415-3-50	342	440	53.1	290	64.1	298	133.2	351.1	175	150

LEGEND

- AWG** — American Wire Gage
- ICF** — Maximum instantaneous current flow during starting.
- kcmil** — Thousand circular mils
- LRA** — Locked Rotor Amps
- MCA** — Minimum Circuit Amps (for wire sizing). Complies with NEC, Section 430-24.
- MOCP** — Maximum Overcurrent Protection
- Rec Fuse** — Recommended dual element fuse amps (150% of compressor RLA). Size up to the next standard fuse size.
- RLA** — Rated Load Amps

*Supply Range — Units are suitable for use on electrical systems where voltage supplied to the unit terminals is not below or above the listed range limits.

NOTES:

1. All units have one field power terminal block.
2. Maximum incoming wire size is as follows:
For units with terminal block:
500 kcmil for all unit sizes 050-071; all voltages
For units with optional non-fused disconnect:
350 kcmil for unit sizes 050-071, 208/230-3-60 voltages.
3/0 AWG for all other voltages.
3. Additional control circuit power is not required.

4. Any field modification of factory wiring must be in compliance with all applicable codes. Field-installed power wires must be rated 75 C minimum.
5. Use copper conductors only.
6. Control circuit power supply is 24-v single phase. Control power is supplied by the factory-installed control transformer.
7. The MOCP of the electrical distribution panel is calculated as follows:

First, calculate the MOCP of each individual chiller. MOCP = 2.25 (Largest RLA) + Sum of the other RLAs. Sum the MOCPs of each individual chiller. This is the MOCP of the electrical distribution panel associated with this bank of chillers. Select the next size down fuse from this value.

The recommended fuse size in amps (RFA) is calculated as follows: RFA = 1.50* (largest RLA) + (Smallest RLA) for the given bank of chillers.

8. The MCA of the electrical distribution panel is calculated as follows:

First, calculate the MCA of each individual chiller. MCA = 1.25 (Largest RLA) + sum of the other RLAs. Sum the MCAs of each individual chiller. This is the MCA of the electrical distribution panel associated with this bank of chillers.



Intertek

Table 13 — Electrical Data — 30MPW050-071 Units without High Condensing Option

UNIT SIZE 30MPW	VOLTS NAMEPLATE	VOLTAGE*		COMPRESSOR A1		COMPRESSOR A2		UNIT			
		MIN	MAX	RLA	LRA	RLA	LRA	MCA	ICF	MOCP	REC FUSE
050	208/230-3-60	187	253	79.4	418	79.4	418	178.7	497.1	250	200
	380-3-60	342	418	48.1	252	48.1	252	108.2	300.3	150	125
	460-3-60	414	508	39.7	212	39.7	212	89.3	251.9	125	100
	575-3-60	518	632	31.8	168	31.8	168	71.6	199.9	100	80
	380/415-3-50	342	440	39.7	212	39.7	212	89.3	251.9	125	100
055	208/230-3-60	187	253	79.4	418	98.4	477	202.4	556.7	300	250
	380-3-60	342	418	48.1	252	59.5	299	122.5	346.8	175	150
	460-3-60	414	508	39.7	212	49.2	241	101.2	280.4	150	125
	575-3-60	518	632	31.8	168	39.3	194	80.9	225.4	110	100
	380/415-3-50	342	440	39.7	212	49.2	241	101.2	280.4	150	125
060	208/230-3-60	187	253	79.4	418	106.7	582	212.8	661.7	300	250
	380-3-60	342	418	48.1	252	64.6	355	128.9	403.2	175	150
	460-3-60	414	508	39.7	212	53.4	280	106.5	320.1	150	125
	575-3-60	518	632	31.8	168	42.7	225	85.2	256.7	125	100
	380/415-3-50	342	440	39.7	212	53.4	280	106.5	320.1	150	125
065	208/230-3-60	187	253	79.4	418	112.5	578	220.0	657.8	300	250
	380-3-60	342	418	48.1	252	67.2	355	132.1	403.5	175	150
	460-3-60	414	508	39.7	212	55.5	290	109.1	329.9	150	125
	575-3-60	518	632	31.8	168	44.4	255	87.3	286.7	125	100
	380/415-3-50	342	440	39.7	212	55.5	290	109.1	329.9	150	125
071	208/230-3-60	187	253	98.4	477	112.5	578	239.0	676.8	350	300
	380-3-60	342	418	59.5	299	67.2	355	143.5	414.9	200	175
	460-3-60	414	508	49.2	241	55.5	290	118.6	339.4	150	150
	575-3-60	518	632	39.3	194	44.4	255	94.8	294.2	125	110
	380/415-3-50	342	440	49.2	241	55.5	290	118.6	339.4	150	150

LEGEND

- AWG** — American Wire Gage
- ICF** — Maximum instantaneous current flow during starting.
- kcmil** — Thousand circular mils
- LRA** — Locked Rotor Amps
- MCA** — Minimum Circuit Amps (for wire sizing). Complies with NEC, Section 430-24.
- MOCP** — Maximum Overcurrent Protection
- Rec Fuse** — Recommended dual element fuse amps (150% of compressor RLA). Size up to the next standard fuse size.
- RLA** — Rated Load Amps

4. Any field modification of factory wiring must be in compliance with all applicable codes. Field-installed power wires must be rated 75°C minimum.
5. Use copper conductors only.
6. Control circuit power supply is 24-v single phase. Control power is supplied by the factory-installed control transformer.
7. The MOCP of the electrical distribution panel is calculated as follows:

First, calculate the MOCP of each individual chiller. $MOCP = 2.25 \text{ (Largest RLA)} + \text{Sum of the other RLAs}$. Sum the MOCPs of each individual chiller. This is the MOCP of the electrical distribution panel associated with this bank of chillers. Select the next size down fuse from this value.

The recommended fuse size in amps (RFA) is calculated as follows: $RFA = 1.50 * \text{(largest RLA)} + \text{(Smallest RLA)}$ for the given bank of chillers.

8. The MCA of the electrical distribution panel is calculated as follows:

First, calculate the MCA of each individual chiller. $MCA = 1.25 \text{ (Largest RLA)} + \text{sum of the other RLAs}$. Sum the MCAs of each individual chiller. This is the MCA of the electrical distribution panel associated with this bank of chillers.

*Supply Range — Units are suitable for use on electrical systems where voltage supplied to the unit terminals is not below or above the listed range limits.

NOTES:

1. All units have one field power terminal block.
2. Maximum incoming wire size is as follows:
For units with terminal block:
500 kcmil for unit sizes 050-071; all voltages.
For units with optional non-fused disconnect:
350 kcmil for unit sizes 050-071, 208/230-3-60 voltages.
3/0 AWG for all other voltages.
3. Additional control circuit power is not required.



Intertek

NOTES:

1. Factory wiring is in accordance with UL 1995 standards. Field modifications or additions must be in compliance with all applicable codes.
2. All units or modules have single point primary power connection. Main power must be supplied from a field or factory supplied disconnect.
3. Wiring for main field supply must be rated 75°C. Use copper conductors only. For unit sizes 016-045:
 - a. Incoming wire size range for terminal block with MCA (minimum circuit amps) up to 120 amps is 14 AWG (American Wire Gauge) to 2/0.
 - b. Incoming wire size range for terminal block with MCA from 120.1 amps to 310 amps is 6 AWG to 350 kcmil.
 - c. Incoming wire size range for non-fused disconnect with MCA up to 50 amps is 10 AWG to 2 AWG.
 - d. Incoming wire size range for non-fused disconnect with MCA from 50.1 amps to 90 amps is 6 AWG to 3/0.
 - e. Incoming wire size range for non-fused disconnect with MCA from 90.1 amps to 250 amps is 4 AWG to 350 kcmil.
 - f. Incoming wire size range for fused disconnect is 6 AWG to 10 AWG.
4. For unit sizes 050-071:
 - a. Incoming wire size range for terminal block 4 AWG to 500 kcmil.
 - b. Incoming wire size range for non-fused disconnect with MCA up to 170 amps is 6 AWG to 3/0.
 - c. Incoming wire size range for non-fused disconnect with MCA above 170.1 amps is 4 AWG to 350 kcmil.
5. Refer to certified dimensional drawings for exact locations of the main power and control power entrance locations.
6. Terminal 24 of the LVT is for control of chilled water pump (CWP) starter. Terminal 20 of the LVT is for control of condenser pump (CNP) starter or condenser fan relay (CFR). The maximum load allowed for the relays is 5 VA sealed. 10 VA inrush at 24 VAC. Field power supply is not required.
7. Terminal 25 of LVT is for an alarm relay. The maximum load allowed for alarm relay is 5 VA sealed, 10 VA inrush at 24 VAC. Field power supply is not required.
8. Make appropriate connections to LVT as shown for energy management board options. The contacts for demand limit and ice done options must be rated for dry circuit application capable of handling 24 VAC load up to 50 mA. Installation of optional energy management board required.
9. Remove jumper between terminals 16 and 17 when field chilled water pump interlock (CWPI) is installed.
10. All discrete inputs are 24 VAC.

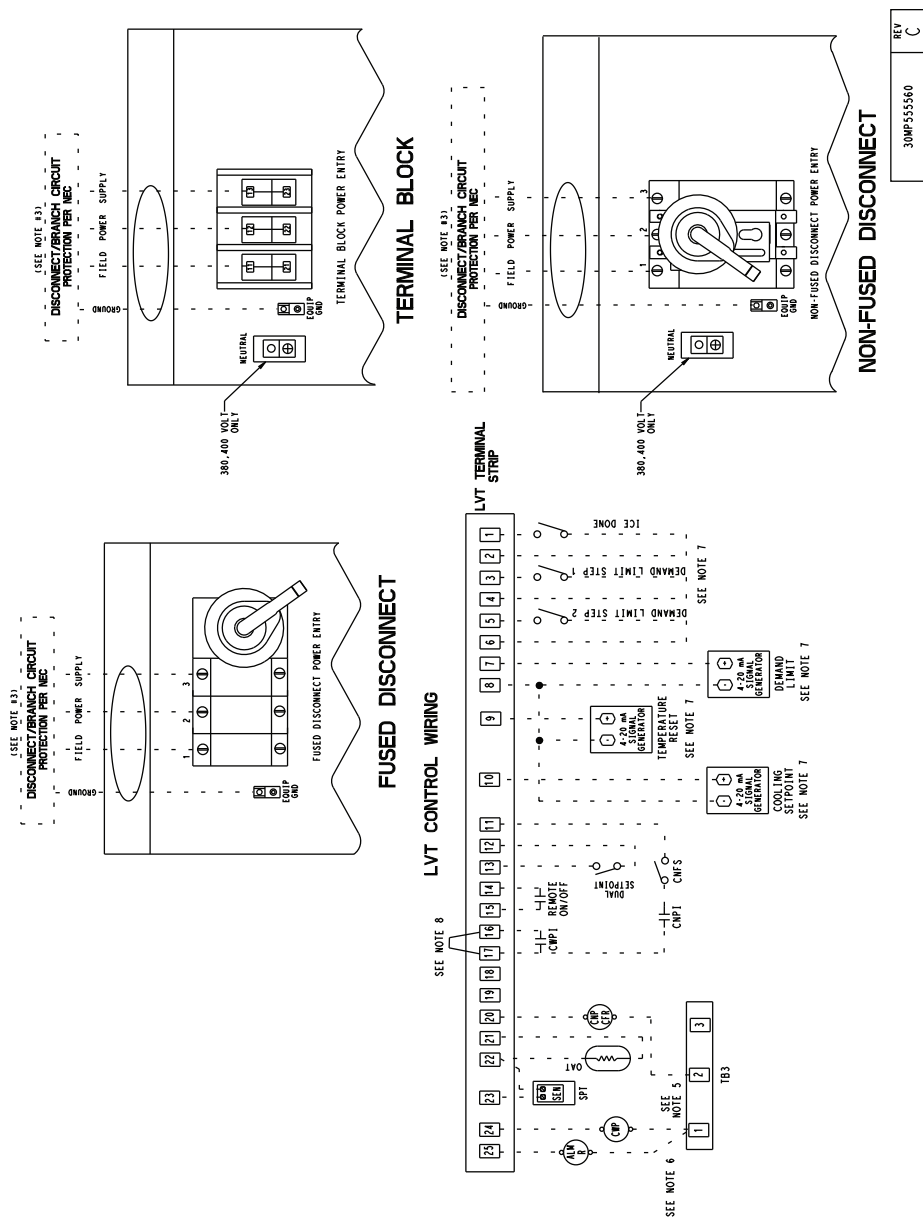

Fig. 39 — Typical Low Voltage Control Wiring

30MP555560
REV C

