



Product Data

AquaForce® Water-Cooled Liquid Screw Chillers

150 to 400 Nominal Tons (528 to 1407 kW)

AQUAFORCE®



30XW150-300



30XW325-400

30XW150-400
Water-Cooled Liquid Screw Chillers

Quality design and construction make the AquaForce® 30XW chillers an excellent choice for modern, efficient chilled water plants.

Carrier's AquaForce 30XW chillers provide a great combination of performance and compact footprint for cooling and heat recovery applications. These chillers provide excellent reliability and efficiency at true operating conditions without compromising the environment.

- Chlorine-free R-134a HFC refrigerant
- Positive displacement, twin screw compressors
- AHRI (Air-Conditioning, Heating, and Refrigeration Institute) certified efficiencies to 0.472 kW per ton IPLV (integrated part load value)
- Dual independent refrigerant circuits (sizes 325-400)
- Compact footprint, less than 48 in. (1219 mm) wide
- Easy to use controls

Small footprint

The 30XW chillers feature a compact footprint and are delivered as a single complete package less than 48 in. (1219 mm) wide for easy installation and minimal indoor space. The 30XW chiller footprints may be up to 30% smaller when compared to other chillers and may require less mechanical room floor space and smaller concrete pads.

Easy installation

The AquaForce® 30XW screw chillers are shipped with starter and unit mounted flow switch installed and can

be shipped with a full R-134a refrigerant charge to minimize installation time. The unit provides single point power connection (using optional control power transformer) and quick, easy piping connections (using Victaulic-type clamp on couplings). The 30XW 200-v, 230-v, 460-v, and 575-v units are designed in accordance with UL (Underwriters Laboratories) and UL Canada standards to minimize electrical inspection time.

Dual circuits (sizes 325-400)

Dual independent refrigerant circuits provide reliable, dependable cooling, excellent part load operation, and redundancy. Each circuit includes its own compressor, electronic expansion valve, filter drier, and sight glass to assure operation.

High efficiency

The Aquaforce 30XW screw chiller efficiency levels meet or exceed energy efficiency requirements of ASHRAE (American Society of Heating, Refrigerating and Air-Conditioning Engineers) 90.1 2010 and CSA (Canadian Standards Association) for both full load and part load operation. The chiller is certified to AHRI standards.

Per AHRI 550/590, chillers operate at design conditions less than one percent of the time. As a result, superior part load efficiency is required for today's chilled water applications. The 30XW chillers deliver integrated part load values (IPLV) as low as 0.472 kW per ton at AHRI conditions while offering the ability to operate in a broad range of applications and climates. This exceptional performance has a significant impact on energy savings and cost of ownership.

Heat recovery

The Aquaforce 30XW screw chillers provide up to 140°F (60°C) leaving condenser water (requires heat machine option) when applied in heat recovery applications. Further, the 30XW unit heat control mode can be used to maintain a constant leaving condenser water temperature. Low source controls provide evaporator suction protection to prevent nuisance trips when operating in heat recovery applications. This flexible capability allows a chiller to meet both cooling and heating requirements providing a high level of interchangeability within a chilled water plant.

Environmental leadership

Carrier has long been committed to the environment and its sustainability. The Aquaforce 30XW screw chiller provides customers with a high-efficiency, chlorine free, long-term solution unaffected by refrigerant phase outs.

Carrier's decision to use non-ozone depleting R-134a refrigerant provides customers with a safe and environmentally balanced choice without compromising efficiency. In addition, R-134a refrigerant was given an A1 safety rating by ASHRAE, meaning that it is among the safest refrigerants available.

Positive displacement screw compression

Positive displacement compression ensures stable operation under all load conditions without the possibility of compressor surge. High-efficiency rotary twin screw with slide valve allows the chillers to exactly match actual load conditions, delivering excellent part load performance.

Factory testing

A quick start-up is assured once installation is complete, since each 30XW unit is manufactured at an ISO (International Organization for Standardization) 9001 listed manufacturing facility to ensure quality. In addition, all 30XW units that are shipped with a full charge of R-134a refrigerant are tested under load at the factory to provide reliable start-up.

Low starting current (inrush)

Dual circuit units (sizes 325-400) stage the start-up of the compressors, thereby reducing the overall current draw by up to 40%.

Table of contents

	Page
Features/Benefits	2
Model Number Nomenclature	5
Capacity Ratings	6
Physical Data	7
Options and Accessories	11
Dimensions	15
Selection Procedure	30
Performance Data	31
Controls	41
Typical Control Wiring Schematic	43
Application Data	44
Typical Piping and Wiring	47
Electrical Data	49
Guide Specifications	54

Constant or variable evaporator flow

Aquaforce 30XW screw chillers are suitable for constant or variable evaporator flow.

Semi-hermetic motor

The Aquaforce 30XW chiller uses motors that are semi-hermetically sealed from the machine room. Refrigerant is used to cool the motor windings.

Carrier's semi-hermetic design eliminates:

- Compressor shaft seals that require maintenance and increase the likelihood of refrigerant leaks.
- Machine room cooling requirements associated with air-cooled motors, which dissipate heat to the mechanical room.
- High noise levels common with air-cooled motors, which radiate noise to the machine room and adjacent areas.
- Shaft alignment problems that occur with open-drive designs during start-up and operation, when equipment temperature variations cause thermal expansion.

Positive pressure design

Positive pressure designs eliminate the need for costly low pressure containment devices, reducing the initial cost of the system. The AquaForce® 30XW chiller's positive pressure design ensures that air, moisture and other performance degrading contaminants are not sucked inside the chiller. Purge units and their associated maintenance are no longer necessary.

Optional refrigerant isolation valves

The optional refrigerant isolation valves enable service personnel to store the refrigerant charge in the evaporator or condenser during servicing. During servicing, the in-chiller storage reduces refrigerant loss and eliminates time-consuming transfer procedures. As a self-contained unit, the AquaForce 30XW chiller does not require additional remote storage systems.

Optional suction service valve(s)

The optional suction service valve(s) allow for further isolation of the compressor from the evaporator vessel.

Marine container shipment

The compact design allows for container shipment to export destinations,

ensuring quality while reducing shipping cost.

Heat exchangers

The Aquaforce 30XW chillers use mechanically cleanable shell and tube evaporators and condensers available with a complete line of waterbox options to meet project specific requirements. One, two, and three pass arrangements are available to meet a wide variety of flow conditions. Nozzle-in-head and marine waterboxes are available to meet 150 psig (1034 kPa) and 300 psig (2068 kPa) piping requirements.

Heat exchanger features include:

ASME certified construction — An independent agency certifies the design, manufacture, and testing of all heat exchangers to American Society of Mechanical Engineers (ASME) standards, ensuring heat exchanger safety, reliability and long life. The ASME stamp is applied to the refrigerant side of the evaporator and condenser.

Electronic thermal-dispersion flow switch — An electronic thermal-dispersion flow switch is included with the evaporator. The switch is factory installed and tested and contains no moving parts for high reliability.

High performance tubing — Carrier's AquaForce chillers use advances in heat transfer technology providing compact, high-efficiency heat exchangers. Tubing with advanced internally and externally enhanced geometry improves chiller performance by reducing overall resistance to heat transfer while reducing fouling.

Evaporator tube expansion —

Evaporator tube expansion at center support sheets prevents unwanted tube movement and vibration, thereby reducing the possibility of premature tube failure. Tube wall thickness is greater at the expansion location, support sheets, and end tube sheets, to provide maximum strength and long tube life.

Closely spaced intermediate support sheets — Support sheets prevent tube sagging and vibration, thereby increasing heat exchanger life.

Refrigerant filter isolation valves — These valves allow filter replacement without pumping down the chiller, reducing service time and expense.

Microprocessor controls

The AquaForce 30XW screw chiller controls communicate in easy to understand English, making it as easy as possible to monitor and control each chiller while maintaining fluid temperatures. Controls are also available with French, Portuguese and Spanish as standard configuration options. These controls result in higher chiller reliability, simplified training and correspondingly lower operational and maintenance costs.

Two user interface options are available, the Touch Pilot™ display and the Navigator™ module.

The Touch Pilot display is an easy to use touch screen display that provides simple navigation for configuration and control of the 30XW units.

Carrier's exclusive handheld Navigator display provides convenience and powerful information in the palm of your hand. The Navigator display helps technicians to quickly diagnose problems and even prevent them from occurring.

All 30XW units are ready to be used with Carrier Comfort Network® (CCN) devices.

Controls features include:

Automatic capacity override —

This function unloads the compressor whenever key safety limits are approached, increasing unit life.

Chilled liquid reset — Reset can be accomplished manually or automatically from the building management system. For a given capacity, reset allows operation at reduced lift, saving energy when warmer chilled liquid can be used.

Demand limiting — This feature limits the power draw of the chiller during peak loading conditions. When incorporated into the CCN building automation system, a red line command holds chillers at their present capacity and prevents any other chillers from starting. If a load shed signal is received, the compressors are unloaded to avoid demand charges whenever possible.

Ramp loading — Ramp loading ensures smooth pulldown of liquid loop temperature and prevents a rapid increase in compressor power consumption during the pulldown period.

Automated controls test — The test can be executed prior to start-up to verify that the entire control system is functioning properly.

Features/Benefits (cont)



365-day real time clock — This feature allows the operator to program a yearly schedule for each week, week-ends, and holidays.

Occupancy schedules — Schedules can be programmed into the controller to ensure that the chiller operates when cooling is required and remains off when not needed by the tenants or process.

Extensive service menu — Access to the service menu can be password-protected to prevent unauthorized access. Built-in diagnostic capabilities assist in troubleshooting and recommend proper corrective action for pre-set alarms, resulting in greater up time.

Alarm file — This file maintains the last 50 time and date-stamped alarm and alert messages in memory. This

function reduces troubleshooting time and cost.

Configuration data backup — Non-volatile memory provides protection during power failures and eliminates time consuming control reconfiguration.



TOUCH PILOT™ DISPLAY

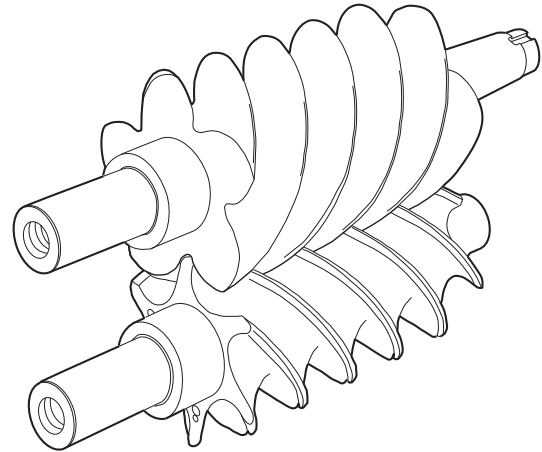

**SMOOTH ROTARY COMPRESSOR
TWIN-SCREW DESIGN**



OPTIONAL NAVIGATOR™ DISPLAY

Model number nomenclature

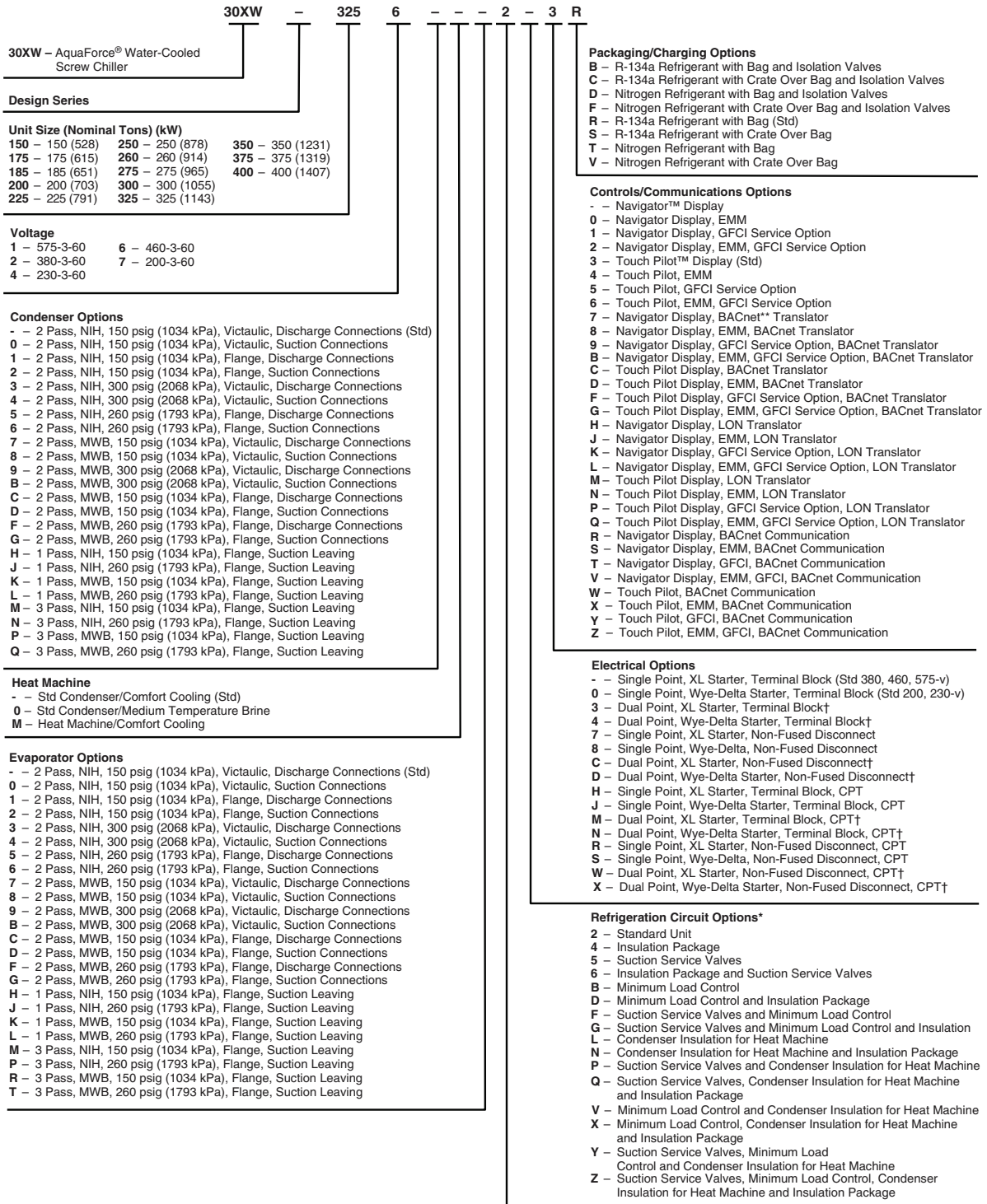

LEGEND

CPT — Control Power Transformer
EMM — Energy Management Module
GFCI — Ground Fault Circuit Interrupter
LON — Local Operating Network
MWB — Marine Waterbox
NIH — Nozzle-In-Head
XL — Across-the-Line Start

*Evaporator insulation is standard.
 †Available on unit sizes 325-400 only.

**BACnet is a registered trademark of ASHRAE (American Society of Heating, Refrigerating and Air-Conditioning Engineers).

Quality Assurance
 ISO 900: 2008-certified processed

Capacity ratings



30XW UNIT SIZE	CAPACITY		INPUT POWER (kW)	EVAPORATOR FLOW		EVAPORATOR PRESSURE DROP		CONDENSER FLOW		CONDENSER PRESSURE DROP		FULL LOAD EFFICIENCY (kW/Ton)	IPLV (kW/Ton)
	Tons	Output (kW)		gpm	L/s	Ft of Water	kPa	gpm	L/s	Ft of Water	kPa		
150	160.2	563.3	104.7	383.1	24.2	11.1	33.2	491.4	31.0	14.7	43.9	0.6537	0.5375
175	170.2	598.4	110.2	407.0	25.7	12.4	37.1	521.3	32.9	16.4	49.0	0.6477	0.5357
185	178.4	627.3	119.7	426.8	26.9	13.5	40.4	549.6	34.7	18.1	54.1	0.6710	0.5436
200	191.2	672.3	123.6	457.4	28.9	15.3	45.7	585.6	36.9	20.3	60.7	0.6462	0.5372
225	222.8	783.4	146.4	532.9	33.6	12.0	35.9	684.0	43.2	14.9	44.5	0.6570	0.5358
250	241.2	848.1	151.6	577.0	36.4	13.8	41.2	735.6	46.4	17.0	50.8	0.6284	0.5248
260	245.1	861.8	165.2	586.2	37.0	14.2	42.4	755.4	47.7	17.8	53.2	0.6739	0.5451
275	262.9	924.4	167.9	628.9	39.7	16.2	48.4	803.6	50.7	20.0	59.8	0.6384	0.5329
300	285.7	1004.5	183.9	683.2	43.1	18.8	56.2	874.3	55.2	23.3	69.6	0.6439	0.5383
325	322.5	1133.9	204.4	771.2	48.7	15.5	46.3	984.5	62.1	11.8	35.3	0.6338	0.4722
350	343.2	1206.7	216.3	820.9	51.8	17.3	51.7	1047.0	66.1	13.3	39.8	0.6303	0.4716
375	364.6	1281.9	236.0	872.0	55.0	19.4	58.0	1117.0	70.5	15.0	44.8	0.6473	0.4751
400	385.2	1354.4	242.4	921.4	58.1	21.4	64.0	1175.0	74.1	16.5	49.3	0.6293	0.4717

LEGEND

AHRI — Air-Conditioning, Heating and Refrigeration Institute
IPLV — Integrated Part Load Value

NOTES:

1. Certified (60 Hz unit) in accordance with AHRI Standard 550/590 at standard rating conditions.
2. Standard rating conditions are as follows:
 Evaporator Conditions:
 Leaving Water Temperature: 44°F (6.7°C)
 Entering Water Temperature: 54°F (12.22°C)
 Condenser Conditions:
 Entering Water Temperature: 85°F (29.4°C)
 Leaving Condenser Water Temperature: 94.3°F (34.6°C)
 Fouling Factor (Evaporator):
 0.00010 hr x sq ft x F per Btuh (0.000018 m² x K per W)
 Fouling Factor (Condenser):
 0.00025 hr x sq ft x F per Btuh (0.000044 m² x K per W)

3. IPLV is a single number part load efficiency value calculated from the system full load efficiency values and corrected for a typical building air-conditioning application.
4. All data in the above table was generated in Packaged Chiller Builder version 3.56. Please refer to the most current version of the Packaged Chiller Builder for the most up-to-date data.
5. Contact Carrier for custom ratings.



30XW150-400 UNIT PHYSICAL DATA — ENGLISH

30XW UNIT SIZE	150	175	185	200	225	250
NOMINAL CAPACITY (tons)	150	175	185	200	225	250
UNIT WEIGHT (lb) (Operating/Shipping)	7281/6826	7421/6966	7356/6901	7551/7096	9936/9217	10,010/9,291
Compressors	Semi-hermetic, twin screw					
Compressor Speed (rpm)	3500					
Compressor Model Number (qty)	06TU483 (1)	06TU483 (1)	06TU554 (1)	06TU554 (1)	06TV680 (1)	06TV680 (1)
Unloading Type	Slide Valve					
Minimum Step Capacity % (standard)	15%					
Minimum Step Capacity % (standard with optional minimum load control)	10%					
Minimum Step Capacity % (heat machine)	30%	30%	30%	30%	20%	20%
Minimum Step Capacity % (heat machine with optional minimum load control)	20%	20%	20%	20%	15%	15%
Economizer	No	Yes	No	Yes	No	Yes
Temperature Relief Valve Connection (in. SAE Flare) (2 per circuit)	—	3/8	—	3/8	—	3/8
REFRIGERANT	HFC, R-134a					
Charge (lb) Circuit A	290	300	290	300	420	430
Charge (lb) Circuit B	—	—	—	—	—	—
Oil	POE, SW-220					
Charge (gal.) Circuit A	6	6	6	6	8	8
Charge (gal.) Circuit B	—	—	—	—	—	—
Evaporator						
Net Fluid Volume (gal.)	33.2	33.2	33.2	33.2	46.3	46.3
Maximum Refrigerant Pressure (psig)	220					
Maximum Fluid Side Pressure (psig)						
Standard	150					
Optional	300 (260 for flange)					
Fluid Connections						
Inlet and Outlet (in.)						
1-Pass NIH or MWB Flange (optional)	6					
2-Pass NIH or MWB Flange (optional)	6					
2-Pass NIH Victaulic (standard)	6	6	6	6	8	8
2-Pass MWB Victaulic (optional)	6					
3-Pass NIH or MWB Flange (optional)	6					
Drain (in. NPT)	3/8					
Relief Valve Connection (in. NPTF)	3/4					
Quantity Per Circuit	1					
Relief Valve Setting (psig)	220					
Flow Rate (lb air/min)	31.7					
Condenser						
Net Fluid Volume (gal.)	33.5	33.5	33.5	33.5	52.0	52.0
Maximum Refrigerant Pressure (psig)	220					
Standard Condenser	220					
Heat Machine	300					
Maximum Fluid Side Pressure (psig)						
Standard	150					
Optional	300 (260 for flange)					
Heat Machine	300 (260 for flange)					
Fluid Connections						
Inlet and Outlet (in.)						
1-Pass NIH or MWB Flange (optional)	6					
2-Pass NIH or MWB Flange (optional)	6					
2-Pass NIH Victaulic (standard)	6	6	6	6	8	8
2-Pass MWB Victaulic (optional)	6					
3-Pass NIH Flange (optional)	4	4	4	4	6	6
3-Pass MWB Flange (optional)	6					
Drain (in. NPT)	3/8					
Relief Valve Connection (in. NPTF) (standard/heat machine)	3/4 / 3/4					
Quantity Per Circuit	2/2					
Relief Valve Setting (psig)	220/300					
Flow Rate (lb air/min)	31.7/46.6					
Temperature Relief Valve Connection (in. SAE Flare)	1/4					
Discharge Line (Qty per Circuit)	1					
Liquid Line (Qty per Circuit)	2	1	2	1	2	1
CHASSIS DIMENSIONS (ft.-in.)						
Length	10 - 7/8			10 - 10 ¹¹ /16		
Width	3 - 7 ³ /8			4 - 0		
Height	5 - 10 ⁷ /8			6 - 6 ¹³ /16		

LEGEND

HFC — Hydrofluorocarbon
MWB — Marine Waterbox
NIH — Nozzle-In-Head
NPTF — National Pipe Thread Female
POE — Polyolester
SAE — Society of Automotive Engineers

NOTE: Weights are shown for standard chiller (2-pass, nozzle-in-head, Victaulic waterboxes).

Physical data (cont)



30XW150-400 UNIT PHYSICAL DATA — ENGLISH (cont)

30XW UNIT SIZE	260	275	300	325	350	375	400
NOMINAL CAPACITY (tons)	260	275	300	325	350	375	400
UNIT WEIGHT (lb) (Operating/Shipping)	9,956/9,237	10,029/9,311	10,043/9,324	14,319/13,173	14,515/13,369	14,468/13,323	14,759/13,614
Compressors	Semi-hermetic, twin screw						
Compressor Speed (rpm)	3500						
Compressor Model Number (qty)	06TV753 (1)	06TV753 (1)	06TV819 (1)	06TU483 (2)	06TU483 (2)	06TU554 (2)	06TU554 (2)
Unloading Type	Slide Valve						
Minimum Step Capacity % (standard)	15%	15%	15%	8%	8%	8%	8%
Minimum Step Capacity % (standard with optional minimum load control)	10%	10%	10%	5.5%	5.5%	5.5%	5.5%
Minimum Step Capacity % (heat machine)	20%						
Minimum Step Capacity % (heat machine with optional minimum load control)	15%						
Economizer	No	Yes	Yes	No	Yes	No	Yes
Temperature Relief Valve Connection (in. SAE Flare) (2 per circuit)	—	3/8	3/8	—	3/8	—	3/8
REFRIGERANT	HFC, R-134a						
Charge (lb) Circuit A	420	430	430	260	270	260	270
Charge (lb) Circuit B	—	—	—	260	270	260	270
Oil	POE, SW-220						
Charge (gal.) Circuit A	8	8	8	6	6	6	6
Charge (gal.) Circuit B	—	—	—	6	6	6	6
Evaporator							
Net Fluid Volume (gal.)	46.3	46.3	46.3	76.0	76.0	76.0	76.0
Maximum Refrigerant Pressure (psig)	220						
Maximum Fluid Side Pressure (psig)							
Standard	150						
Optional	300 (260 for flange)						
Fluid Connections							
Inlet and Outlet (in.)							
1-Pass NIH or MWB Flange (optional)	6						
2-Pass NIH or MWB Flange (optional)	6						
2-Pass NIH Victaulic (standard)	8						
2-Pass MWB Victaulic (optional)	6						
3-Pass NIH or MWB Flange (optional)	6						
Drain (in. NPT)	3/8						
Relief Valve Connection (in. NPTF)	3/4						
Quantity Per Circuit	1						
Relief Valve Setting (psig)	220						
Flow Rate (lb air/min)	31.7						
Condenser							
Net Fluid Volume (gal.)	52.0	52.0	52.0	82.6	82.6	82.6	82.6
Maximum Refrigerant Pressure (psig)							
Standard Condenser	220						
Heat Machine	300						
Maximum Fluid Side Pressure (psig)							
Standard	150						
Optional	300 (260 for flange)						
Heat Machine	300 (260 for flange)						
Fluid Connections							
Inlet and Outlet (in.)							
1-Pass NIH or MWB Flange (optional)	6						
2-Pass NIH or MWB Flange (optional)	6						
2-Pass NIH Victaulic (standard)	8						
2-Pass MWB Victaulic (optional)	6						
3-Pass NIH Flange (optional)	6						
3-Pass MWB Flange (optional)	6						
Drain (in. NPT)	3/8						
Relief Valve Connection (in. NPTF) (standard/heat machine)	3/4 / 3/4						
Quantity Per Circuit	2/2						
Relief Valve Setting (psig)	220/300						
Flow Rate (lb air/min)	31.7/46.6						
Temperature Relief Valve Connection (in. SAE Flare)	1/4						
Discharge Line (Qty per Circuit)	1						
Liquid Line (Qty per Circuit)	2	1	1	2	1	2	1
CHASSIS DIMENSIONS (ft-in.)							
Length	10 - 10 ¹¹ / ₁₆			13 - 3 ³ / ₄			
Width	4 - 0			4 - 0			
Height	6 - 6 ¹³ / ₁₆			6 - 6 ¹ / ₁₆			

LEGEND

HFC — Hydrofluorocarbon
MWB — Marine Waterbox
NIH — Nozzle-In-Head
NPTF — National Pipe Thread Female
POE — Polyolester
SAE — Society of Automotive Engineers

NOTE: Weights are shown for standard chiller (2-pass, nozzle-in-head, Victaulic waterboxes).

30XW150-400 UNIT PHYSICAL DATA — SI

30XW UNIT SIZE	150	175	185	200	225	250
NOMINAL CAPACITY (kW)	528	615	651	703	791	878
UNIT WEIGHT (kg) (Operating/Shipping)	3303/3096	3366/3160	3337/3130	3425/3219	4507/4181	4540/4214
Compressors	Semi-hermetic, twin screw					
Compressor Speed (r/s)	58.3					
Compressor Model Number (qty)	06TU483 (1)	06TU483 (1)	06TU554 (1)	06TU554 (1)	06TV680 (1)	06TV680 (1)
Unloading Type	Slide Valve					
Minimum Step Capacity % (standard)	15%					
Minimum Step Capacity % (standard with optional minimum load control)	10%					
Minimum Step Capacity % (heat machine)	30%	30%	30%	30%	20%	20%
Minimum Step Capacity % (heat machine with optional minimum load control)	20%	20%	20%	20%	15%	15%
Economizer	No	Yes	No	Yes	No	Yes
Temperature Relief Valve Connection (in. SAE Flare) (2 per circuit)	—	3/8	—	3/8	—	3/8
REFRIGERANT	HFC, R-134a					
Charge (kg) Circuit A	131.5	136.1	131.5	136.1	190.5	195.0
Charge (kg) Circuit B	—	—	—	—	—	—
Oil	POE, 220					
Charge (L) Circuit A	22.7	22.7	22.7	22.7	30.3	30.3
Charge (L) Circuit B	—	—	—	—	—	—
Evaporator	1517					
Net Fluid Volume (L)	125.7	125.7	125.7	125.7	175.3	175.3
Maximum Refrigerant Pressure (kPa)	1517					
Maximum Fluid Side Pressure (kPa)	1034					
Standard	2068 (1793 for flange)					
Optional	2068 (1793 for flange)					
Fluid Connections	1034					
Inlet and Outlet (in.)	2068 (1793 for flange)					
1-Pass NIH or MWB Flange (optional)	6					
2-Pass NIH or MWB Flange (optional)	6					
2-Pass NIH Victaulic (standard)	6	6	6	6	8	8
2-Pass MWB Victaulic (optional)	6					
3-Pass NIH or MWB Flange (optional)	6					
Drain (in. NPT)	3/8					
Relief Valve Connection (in. NPTF)	3/4					
Quantity Per Circuit	1					
Relief Valve Setting (kPa)	1517					
Flow Rate (kg air/min)	14.38					
Condenser	1517					
Net Fluid Volume (L)	126.8	126.8	126.8	126.8	196.8	196.8
Maximum Refrigerant Pressure (kPa)	1517					
Standard Condenser	1517					
Heat Machine	2068					
Maximum Fluid Side Pressure (kPa)	1034					
Standard	2068 (1793 for flange)					
Optional	2068 (1793 for flange)					
Heat Machine	2068 (1793 for flange)					
Fluid Connections	1034					
Inlet and Outlet (in.)	2068 (1793 for flange)					
1-Pass NIH or MWB Flange (optional)	6					
2-Pass NIH or MWB Flange (optional)	6					
2-Pass NIH Victaulic (standard)	6	6	6	6	8	8
2-Pass MWB Victaulic (optional)	6					
3-Pass NIH Flange (optional)	4	4	4	4	6	6
3-Pass MWB Flange (optional)	6					
Drain (in. NPT)	3/8					
Relief Valve Connection (in. NPTF) (standard/heat machine)	3/4 / 3/4					
Quantity Per Circuit	2/2					
Relief Valve Setting (kPa)	1517/2068					
Flow Rate (kg air/min)	14.38/21.1					
Temperature Relief Valve Connection (in. SAE Flare)	1/4					
Discharge Line (Qty per Circuit)	1					
Liquid Line (Qty per Circuit)	2	1	2	1	2	1
CHASSIS DIMENSIONS (mm)	3070.2					
Length	1139.8					
Width	1806.6					
Height	3319.5			1219.2		
	2001.8			2001.8		

LEGEND

HFC — Hydrofluorocarbon **NPTF** — National Pipe Thread Female
MWB — Marine Waterbox **POE** — Polyolester
NIH — Nozzle-In-Head **SAE** — Society of Automotive Engineers

NOTE: Weights are shown for standard chiller (2-pass, nozzle-in-head, Victaulic waterboxes).

Physical data (cont)



30XW150-400 UNIT PHYSICAL DATA — SI (cont)

30XW UNIT SIZE	260	275	300	325	350	375	400
NOMINAL CAPACITY (kW)	914	965	1053	1143	1231	1319	1407
UNIT WEIGHT (kg) (Operating/Shipping)	4516/4190	4549/4223	4555/4229	6495/5975	6584/6064	6563/6043	6695/6175
Compressors	Semi-hermetic, twin screw						
Compressor Speed (r/s)	58.3						
Compressor Model Number (qty)	06TV753 (1)	06TV753 (1)	06TV819 (1)	06TU483 (2)	06TU483 (2)	06TU554 (2)	06TU554 (2)
Unloading Type	Slide Valve						
Minimum Step Capacity % (standard)	15%	15%	15%	8%	8%	8%	8%
Minimum Step Capacity % (standard with optional minimum load control)	10%	10%	10%	5.5%	5.5%	5.5%	5.5%
Minimum Step Capacity % (heat machine)				20%			
Minimum Step Capacity % (heat machine with optional minimum load control)				15%			
Economizer	No	Yes	Yes	No	Yes	No	Yes
Temperature Relief Valve Connection (in. SAE Flare) (2 per circuit)	—	3/8	3/8	—	3/8	—	3/8
REFRIGERANT	HFC, R-134a						
Charge (kg) Circuit A	190.5	195.0	195.0	117.9	122.5	117.9	122.5
Charge (kg) Circuit B	—	—	—	117.9	122.5	117.9	122.5
Oil	POE, SW-220						
Charge (L) Circuit A	30.3	30.3	30.3	22.7	22.7	22.7	22.7
Charge (L) Circuit B	—	—	—	22.7	22.7	22.7	22.7
Evaporator	175.3 175.3 175.3 287.7 287.7 287.7 287.7						
Net Fluid Volume (L)							
Maximum Refrigerant Pressure (kPa)	1517						
Maximum Fluid Side Pressure (kPa)							
Standard	1034						
Optional	2068 (1793 for flange)						
Fluid Connections							
Inlet and Outlet (in.)							
1-Pass NIH or MWB Flange (optional)	6						
2-Pass NIH or MWB Flange (optional)	6						
2-Pass NIH Victaulic (standard)	8						
2-Pass MWB Victaulic (optional)	6						
3-Pass NIH or MWB Flange (optional)	6						
Drain (in. NPT)	3/8						
Relief Valve Connection (in. NPTF)	3/4						
Quantity Per Circuit	1						
Relief Valve Setting (kPa)	1517						
Flow Rate (kg air/min)	14.38						
Condenser	196.8 196.8 196.8 312.7 312.7 312.7 312.7						
Net Fluid Volume (L)							
Maximum Refrigerant Pressure (kPa)	1517						
Standard Condenser							
Heat Machine	2068						
Maximum Fluid Side Pressure (kPa)							
Standard	1034						
Optional	2068 (1793 for flange)						
Heat Machine	2068 (1793 for flange)						
Fluid Connections							
Inlet and Outlet (in.)							
1-Pass NIH or MWB Flange (optional)	6						
2-Pass NIH or MWB Flange (optional)	6						
2-Pass NIH Victaulic (standard)	8						
2-Pass MWB Victaulic (optional)	6						
3-Pass NIH Flange (optional)	6						
3-Pass MWB Flange (optional)	6						
Drain (in. NPT)	3/8						
Relief Valve Connection (in. NPTF) (standard/heat machine)	3/4 / 3/4						
Quantity Per Circuit	2/2						
Relief Valve Setting (kPa)	1517/2068						
Flow Rate (kg air/min)	14.38/21.1						
Temperature Relief Valve Connection (in. SAE Flare)	1/4						
Discharge Line (Qty per Circuit)	1						
Liquid Line (Qty per Circuit)	2	1	1	2	1	2	1
CHASSIS DIMENSIONS (mm)							
Length	3319.5			4057.7			
Width	1219.5			1215.0			
Height	2001.8			1998.7			

LEGEND

HFC — Hydrofluorocarbon
MWB — Marine Waterbox
NIH — Nozzle-In-Head
NPTF — National Pipe Thread Female
POE — Polyolester
SAE — Society of Automotive Engineers

NOTE: Weights are shown for standard chiller (2-pass, nozzle-in-head, Victaulic waterboxes).

Options and accessories



ITEM	FACTORY-INSTALLED OPTION	FIELD-INSTALLED ACCESSORY
Controls Options		
Navigator Hand-Held Display	X	X
Remote Enhanced Display		X
BACnet Translator Control	X	X
BACnet Communications	X	
LON Translator Control	X	X
Energy Management Module	X	X
Evaporator Options		
Medium Temperature Brine*	X	
One-Pass Evaporator Head	X	
Three-Pass Evaporator Head	X	
Marine Waterboxes	X	
Flanged Connections	X	
Isolation Valves	X	
Suction Service Valve(s)	X	
Insulation Package	X	
300 psig (2068 kPa) Operating Pressure	X	
Condenser Options		
Heat Machine Condenser	X	
One-Pass Condenser Head	X	
Three-Pass Condenser Head	X	
Marine Waterboxes	X	
Flanged Connections	X	
300 psig (2068 kPa) Operating Pressure	X	
Starter Options		
Wye-Delta Starter	X	
Dual Point Power (sizes 325-400)	X	
Non-Fused Disconnect	X	
Control Transformer	X	
115-v GFCI Convenience Outlet	X	
Unit Options		
Minimum Load Control	X	
Temperature Reset Sensor		X
Nitrogen Charge	X	
Crate for Shipment	X	
Vibration Pads		X
Vibration Isolation Springs		X
Sound Attenuation Packages		X

*The following units are not available with the brine option: sizes 150, 185, 225, 260, 325 and 375.

Factory-installed options

Navigator™ module provides a portable, hand-held display for convenient access to unit status, operation, configuration and troubleshooting diagnostics capability. The four-line, 20-character LCD (liquid crystal display) display provides clear language information in English, French, Spanish, or Portuguese. The Navigator module features an industrial grade extension cord and magnets located on the back of the weatherproof enclosure to allow attachment to sheet metal components for hands free operation.

BACnet translator control provides an interface between the chiller and BACnet Local Area Network (LAN, i.e., MS/TP EIA 485). The BACnet translator control is also available as a field-installed accessory.

BACnet communications option provides factory-installed communication capability with a BACnet MS/TP network. Allows integration with i-Vu® open control system or a BACnet building automation system.

LON translator control provides an interface between the chiller and Local Operating Network (LON, i.e., LON-Works¹ FT-10A ANSI/EIA-709.1). The LON translator control is also available as a field-installed accessory.

Energy management module provides energy management capabilities to minimize chiller energy consumption. Several features are provided with this module including leaving fluid temperature reset, cooling set point reset or demand limit control from a 4 to 20 mA signal, 2-point demand limit control (from 0 to 100%) activated by a remote contact closure, and discrete input for "Ice Done" indication for ice stage system interface.

Medium temperature brine option allows for leaving chilled fluid temperatures to be set to below 40°F (4.4°C). The lowest available fluid temperature is a function of brine type, but may not be less than 14°F (-10°C). Refrigeration circuit components, such as the expansion device, are modified at the factory to correct for the lower refrigeration flow rates. Special installation requirements apply to brine units. See Brine Applications section on page 44. The optional insulation package is required when the medium temperature brine option is selected.

The 300 psig (2068 kPa) evaporator operating pressure option allows operation for water-side pressure up to 300 psig (2068 kPa).

The 300 psig (2068 kPa) condenser operating pressure option allows operation for water-side pressure up to 300 psig (2068 kPa).

Minimum load control allows additional capacity reduction for unit operation below the minimum step of unloading via hot gas bypass.

Marine waterboxes provide water piping connections extending from the side of the waterbox (as opposed to extending from the end of the waterbox). This option also includes a removable bolt on waterbox cover allowing access to the heat exchanger tubes without breaking the existing field piping. This option is available for both the evaporator and condenser.

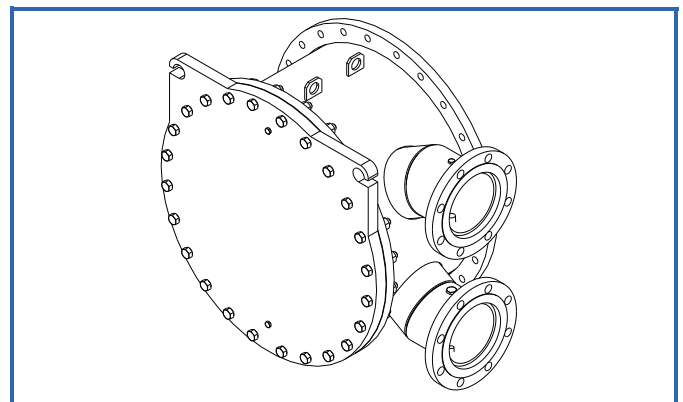

1. LonWorks is a registered trademark of Echelon Corporation.

Flanged connection option provides an ANSI (American National Standards Institute) flange on the end of the chiller water piping for connection to a customer-supplied mating flange in the field piping. This option is available for both the evaporator and condenser.

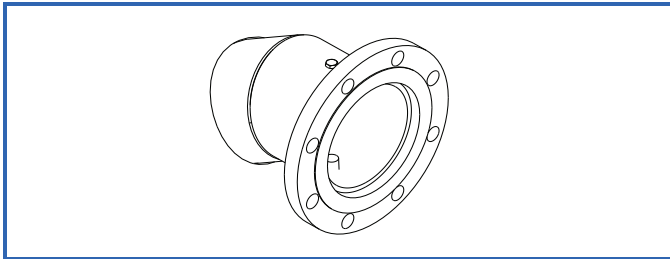

One-pass evaporator provides a lower pressure drop through the evaporator for applications with low delta T (temperature) or high flow or where the evaporators are piped in a series or side stream arrangement. One-pass evaporator is only available with flanged connections and with suction end leaving water connection.

Three-pass evaporator provides a greater efficiency for brine applications and in applications with a high delta T and low flow. Three-pass evaporator is only available with flanged connections and suction end leaving water connection.

Heat machine condenser allows operation with up to 140°F (60°C) leaving condenser water temperature on 30XW units (see E-CAT for selections). In addition, this option provides factory-installed thermal insulation on the condenser, condenser flow switch and leaving condenser water temperature sensor to facilitate operating in HEAT mode. Heat machine units require field-installed thermal insulation on the compressor, discharge piping, oil lines, and water boxes because of high temperature. The heat machine units require the 300 psig (2068 kPa) condenser option.

One-pass condenser provides a lower pressure drop through the condenser for applications with low delta T or high flow or where the condensers are piped in a series. The one-pass condenser option is only available with flanged connections and with a suction end leaving water connection.

Three-pass condenser provides a greater efficiency for heat machine applications with a high delta T and low flow. The three-pass condenser option is only available with flanged connections and suction end leaving water connection.

Wye-delta start is an alternate starting method which reduces the inrush current when starting the compressor. Wye delta start is standard on 208-v, and 230-v units, optional for 380-v, 460-v, and 575-v.

Dual point power provides a means for connecting two sources of power to dual compressor 30XW chillers (sizes 325-400 only). One source of power is wired to operate the compressor on the A circuit and one source of power is wired to operate the compressor on the B circuit of the chiller.

Non-fused disconnect provides a no load, lockable, through the door handle disconnect for unit power on the chiller. On dual compressor units, two disconnects are provided (one for each compressor). On dual point power units, one disconnect is provided for each of the two main power supplies. This disconnect does not remove the control circuit from power supply.

Control transformer is sized to supply the needs of the control circuit from the main power supply.

115-v GFCI convenience outlet includes 4 amp GFI (ground fault interrupt) receptacle. Convenience outlet is 115-v female receptacle. Not available with 380-v units.

Nitrogen charge provides a 15 psig (103.4 kPa) charge of nitrogen instead of a full factory charge of R-134a refrigerant to keep the chiller refrigerant circuit dry during shipment. This option is recommended for applications where the unit will be disassembled prior to installation. Units shipped with a nitrogen charge will receive an electrical continuity test at the factory prior to shipment.

Crate for shipment provides a wooden crate around the chiller. The chiller is bagged prior to being placed in the crate. This option is recommended for export orders.

Optional refrigerant isolation valves enable service personnel to store the refrigerant charge in the evaporator or condenser during servicing. During servicing, the in-chiller storage reduces refrigerant loss and eliminates time-consuming transfer procedures. As a self-contained unit, the AquaForce® 30XW chiller does not require additional remote storage systems.

Suction service valve(s) allow for further isolation of the compressor from the evaporator vessel.

Insulation package provides 3/4-in. thermal insulation on compressor suction housing, and 3/8-in. thermal insulation on suction line.

Field-installed accessories

Remote enhanced display is a remotely mounted indoor 40-character per line, 16-line display panel for unit monitoring and diagnostics.

BACnet translator control provides an interface between the chiller and BACnet Local Area Network (LAN, i.e., MS/TP EIA 485). The BACnet translator control is also available as a factory-installed option.

LON translator control provides an interface between the chiller and Local Operating Network (LON, i.e., LON-Works FT-10A ANSI/EIA-709.1). The LON translator control is also available as a factory-installed option.

Energy management module provides energy management capabilities to minimize chiller energy consumption. Several features are provided with this module including leaving fluid temperature reset, cooling set point reset or demand limit control from a 4 to 20 mA signal, 2-point demand limit control (from 0 to 100%) activated by a remote contact closure, and discrete input for "Ice Done" indication for ice stage system interface.

Temperature reset sensor provides temperature reset capability from either the occupied space or outdoor temperature sensor.

NOTE: Temperature reset capability using return temperature is standard.

Vibration isolation pads are neoprene pads for installation under the chiller feet at the jobsite.

Vibration springs provide a set of non-seismic spring isolators for installation at the jobsite.

IMPORTANT: For installations adjacent to areas that are sensitive to noise and/or vibration, use the services of a qualified consulting engineer or acoustics expert to determine whether or not these springs will provide adequate noise/vibration suppression.

Navigator™ module provides a portable, hand-held display for convenient access to unit status, operation, configuration and troubleshooting diagnostics capability. The four-line, 20-character LCD (liquid crystal display) display provides clear language information in English, French, Spanish, or Portuguese. The Navigator module features an industrial grade extension chord and magnets located on the back of the weatherproof enclosure to allow attachment to sheet metal components for hands free operation.

Field-supplied and field-installed insulation

Evaporator waterbox insulation must be field supplied and field installed. When insulating waterbox and tube sheets, allow for service access and removal of covers. To estimate waterbox and tube sheet cover areas, refer to the Field-Supplied and Field-Installed Insulation figure on the next page and certified drawings.

Insulation for discharge piping between the compressor and condenser must be field installed on heat machine units. Refer to the figure on the next page.

Condenser waterbox insulation must be field supplied and field installed on heat machine units. When insulating waterbox and tube sheets, allow for service access and removal of covers. To estimate waterbox and tube sheet cover areas, refer to certified drawings and the Field-Supplied and Field-Installed Insulation figure on the next page.

Additional compressor insulation may be required to prevent condensation if the unit is installed in an unconditioned mechanical space with high temperature and relative humidity. Field-Supplied and Field-Installed Insulation should be applied to the remainder of the compressor motor housing, as necessary. Refer to the figure on the next page for insulation details.

Factory insulation provides excellent protection against condensation under most operating conditions as indicated in the Condensation vs Relative Humidity table. If temperatures in the equipment area exceed the maximum design conditions, extra insulation is recommended.

CONDENSATION VS RELATIVE HUMIDITY*

AMOUNT OF CONDENSATION	ROOM DRY-BULB TEMP		
	80°F (27°C)	90°F (32°C)	100°F (38°C)
	% Relative Humidity		
None	80	76	70
Slight	87	84	77
Extensive	94	91	84

*These approximate figures are based on 35°F (1.7°C) saturated suction temperature. A 2°F (1.1°C) change in saturated suction temperature changes the relative humidity values by 1% in the same direction.

FIELD-SUPPLIED AND FIELD-INSTALLED INSULATION

30XW150-300 UNITS

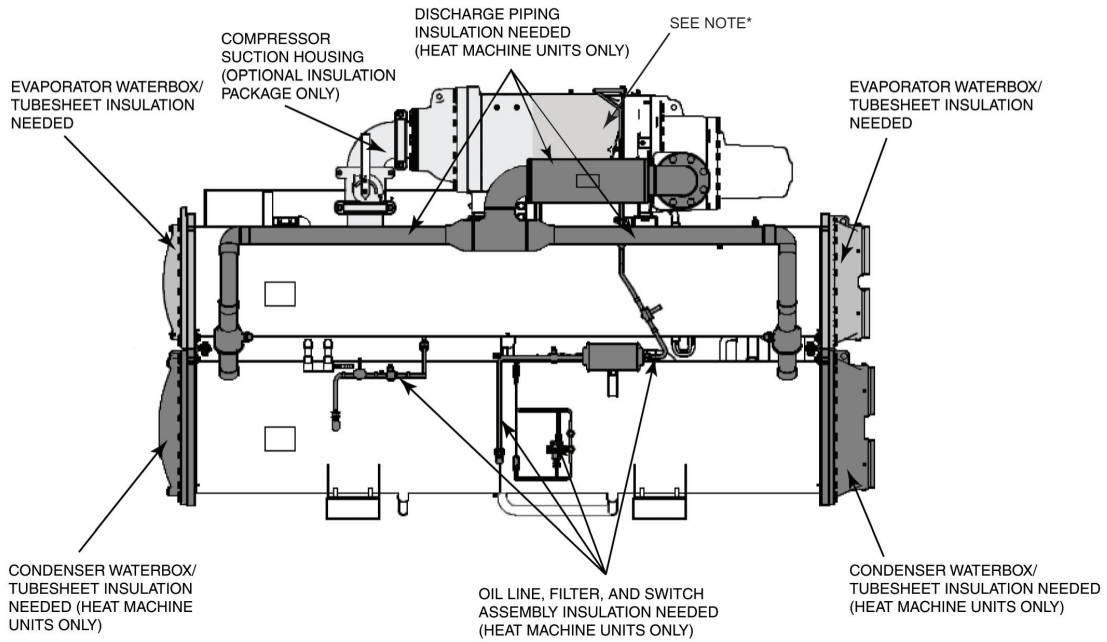

30XW325-400 UNITS

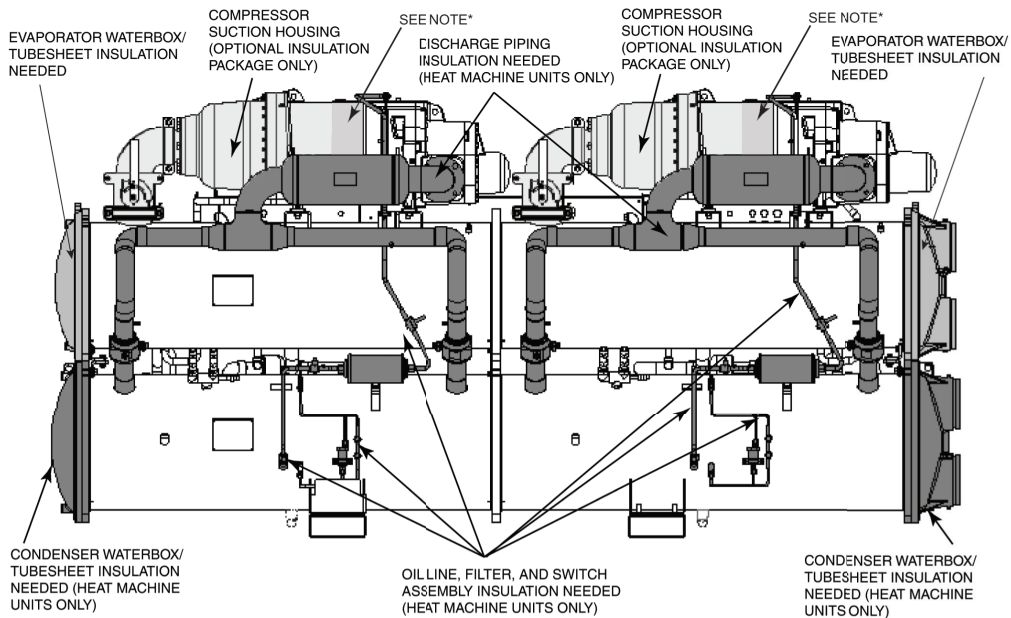

* Further field installed insulation may be required based on the Condensation vs. Relative Humidity Table shown on page 13.

NOTES:

1. Field-installed insulation for standard units shown in medium gray.
2. Field-installed insulation for heat machine units shown in dark gray.
3. Factory-installed insulation for optional insulation kit shown in light gray.
4. Back of the unit shown.
5. Discharge piping insulation or discharge line sound kit needed (heat machines only).

30XW150-200 UNIT DIMENSIONS

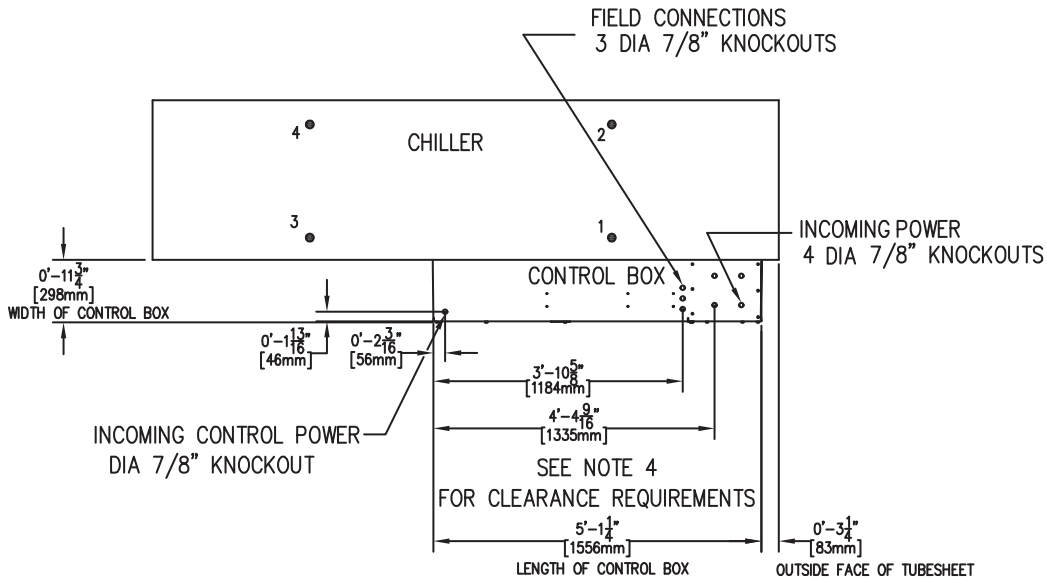

STANDARD 30XW150-200 UNIT DIMENSIONS

30XW UNIT SIZE	OPERATING WEIGHT		MOUNTING LOCATION WEIGHT							
			1		2		3		4	
	lb	kg	lb	kg	lb	kg	lb	kg	lb	kg
150	7281	3303	1312	595	1772	804	1785	810	2411	1094
175	7421	3366	1338	607	1806	819	1820	825	2457	1115
185	7356	3336	1326	601	1790	812	1804	818	2436	1105
200	7551	3425	1361	617	1838	834	1852	840	2500	1134

NOTE: Weights shown for standard chiller (2 pass with NIH, victaulic waterboxes).

30XW150-200 UNIT AND WATERBOX SPECIFICATIONS

A	Evaporator Heat Exchanger Length — 9'-1 1/16" [2770 mm]	C
B	Condenser Heat Exchanger Length — 9'-1 1/16" [2770 mm]	D

Overall Length = Larger of A or B + 9' - 1 1/16" [2770 mm] + larger of C or D, where:

A = evaporator discharge end waterbox length B = condenser discharge end waterbox length
 C = evaporator suction end waterbox length D = condenser suction end waterbox length

TYPE	WATERBOX ADDITIONAL LENGTH ADDERS				WATERBOX WEIGHT ADDERS			
	EVAP		COND		EVAP		COND	
	ft-in.	mm	ft-in.	mm	lb	kg	lb	kg
Return Cover	0-4 1/16	103	0-4 3/8	111	Std	Std	Std	Std
NIH 2 Pass Victaulic	0-7 1/8	181	0-7 7/16	189	Std	Std	Std	Std
NIH 2 Pass Flange	0-4 5/8	117	1-1 7/8	352	137	62.1	146	66.2
NIH 1 Pass Flange	1-0 5/8	321	1-1 7/8	352	188	85.3	244	110.7
NIH 3 Pass Flange	1-0 5/8	321	1-1 7/8	352	198	89.8	185	83.9
MWB 2 Pass Victaulic	1-4 5/16	414	1-4 5/16	414	232	105.2	274	124.3
MWB 2 Pass Flange	1-4 5/16	414	1-4 5/16	414	265	120.2	357	161.9
MWB 1 Pass Flange	1-4 5/16	414	1-4 5/16	414	508	230.4	598	271.3
MWB 3 Pass Flange	1-4 5/16	414	1-4 5/16	N/A	539	244.5	706	320.2

LEGEND

MWB — Marine Waterbox **NIH** — Nozzle-In-Head

NOTES:

1. Add the additional weight to the standard unit operating weight to find the total weight of the unit.
2. ☉ Denotes center of gravity.
3. Dimensions shown in ft-in. [mm] unless noted.
4. The recommended service clearance for the machine is 3 ft [914 mm] at the front and rear, 2 ft [610 mm] at the top, and the tube length at one end and 3 ft [914 mm] at the opposite end. Consult local electrical codes for minimum clearance requirements on control panel side.
5. Victaulic nozzles are standard on all units. A flow switch is factory-installed in evaporator inlet Victaulic nozzle.
6. Maximum fluid side pressure of condenser or evaporator is 150 psig [1034 kPa] (standard) or 300 psig [2068 kPa] (optional).
7. Operating weight includes weight of water, refrigerant, and oil.

30XW150-200 UNIT DIMENSIONS (cont)

FRONT VIEW — DISCHARGE END

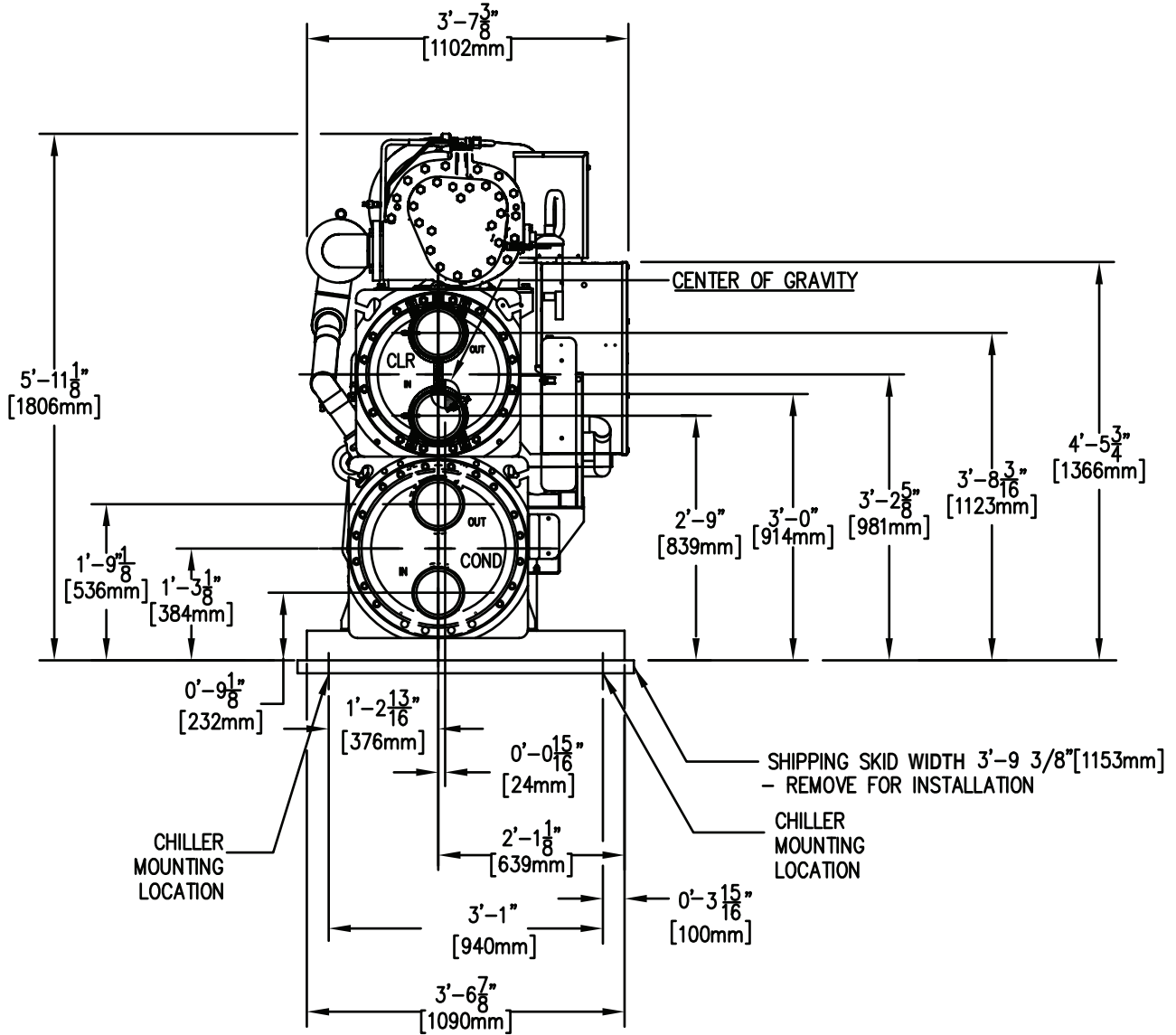

30XW150-200 UNIT DIMENSIONS (cont)

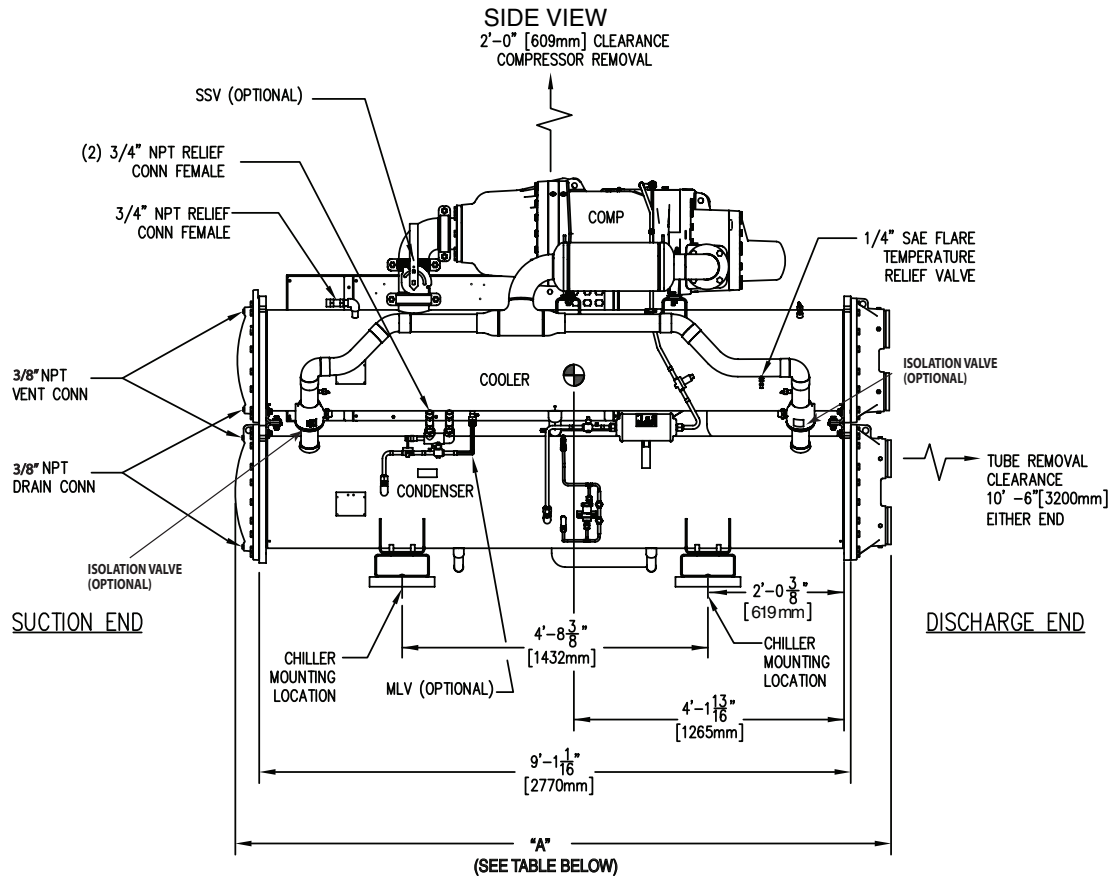

CHILLER DIMENSIONS

CONNECTION	PASSES COOLER /COND	WATER BOX COOLER/ COND	PRESSURE PSIG	NOZZLE TYPE	"A" ft-in. [mm]	ADDED WGT lb [kg]
STD ENDS	2P / 2P	NIH / NIH	150 or 300	VIC	10-0 7/8 [3071]	0
STD ENDS	2P / 2P	NIH / NIH	150 or 300	FLG	10-10 1/16 [3304]	283 [128]
STD ENDS	2P / 2P	NIH / MWB	150 or 300	VIC	10-9 13/16 [3297]	274 [124]
STD ENDS	2P / 2P	NIH / MWB	150 or 300	FLG	10-9 13/16 [3297]	357 [162]
STD ENDS	2P / 2P	MWB / NIH	150 or 300	VIC	10-9 13/16 [3297]	231 [105]
STD ENDS	2P / 2P	MWB / NIH	150 or 300	FLG	10-9 13/16 [3297]	265 [120]
STD ENDS	2P / 2P	MWB / MWB	150 or 300	VIC	10-9 13/16 [3297]	505 [209]
STD ENDS	2P / 2P	MWB / MWB	150 or 300	FLG	10-9 13/16 [3297]	621 [282]
STD ENDS	2P / 3P	NIH / NIH	150 or 300	FLG	11-4 5/8 [3469]	322 [146]
STD ENDS	2P / 3P	NIH / MWB	150 or 300	FLG	11-9 3/4 [3600]	843 [382]
OPP ENDS	1P / 1P	NIH / NIH	150 or 300	FLG	11-4 13/16 [3474]	432 [196]
OPP ENDS	1P / 1P	NIH / MWB	150 or 300	FLG	11-9 3/4 [3600]	787 [357]
OPP ENDS	1P / 1P	MWB / NIH	150 or 300	FLG	11-9 3/4 [3600]	751 [341]
OPP ENDS	1P / 1P	MWB / MWB	150 or 300	FLG	11-9 3/4 [3600]	1106 [502]
OPP ENDS	2P / 2P	NIH / NIH	150 or 300	VIC	10-0 7/8 [3071]	0
OPP ENDS	2P / 2P	NIH / NIH	150 or 300	FLG	10-10 1/16 [3304]	283 [128]
OPP ENDS	2P / 2P	NIH / MWB	150 or 300	VIC	10-9 13/16 [3297]	274 [124]
OPP ENDS	2P / 2P	NIH / MWB	150 or 300	FLG	10-9 13/16 [3297]	357 [162]
OPP ENDS	2P / 2P	MWB / NIH	150 or 300	VIC	10-9 13/16 [3297]	231 [105]
OPP ENDS	2P / 2P	MWB / NIH	150 or 300	FLG	10-9 13/16 [3297]	265 [120]
OPP ENDS	2P / 2P	MWB / MWB	150 or 300	VIC	10-9 13/16 [3297]	505 [229]
OPP ENDS	2P / 2P	MWB / MWB	150 or 300	FLG	10-9 13/16 [3297]	621 [282]
OPP ENDS	3P / 1P	NIH / NIH	150 or 300	FLG	11-4 13/16 [3474]	442 [200]
OPP ENDS	3P / 1P	NIH / MWB	150 or 300	FLG	11-9 3/4 [3600]	796 [361]
OPP ENDS	3P / 1P	MWB / NIH	150 or 300	FLG	11-9 3/4 [3600]	783 [355]
OPP ENDS	3P / 1P	MWB / MWB	150 or 300	FLG	11-9 3/4 [3600]	1138 [516]

LEGEND

- 1P — 1 Pass
- 2P — 2 Pass
- 3P — 3 Pass
- FLG — Flange
- MLV — Minimum Load Valve
- MWB — Marine Water Box
- NIH — Nozzle-In-Head
- OPP ENDS — Opposite Ends
- SAE — Society of Automotive Engineers
- SSV — Suction Service Valve
- STD ENDS — Standard Ends
- VIC — Victaulic

30XW150-200 UNIT DIMENSIONS (cont)

NIH EVAPORATOR

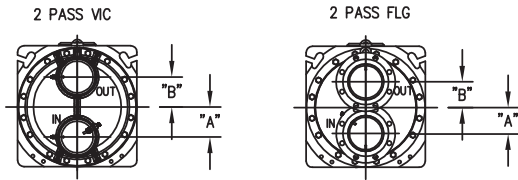

COMPRESSOR DISCHARGE END

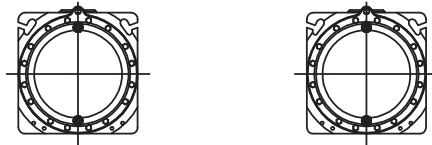

COMPRESSOR SUCTION END

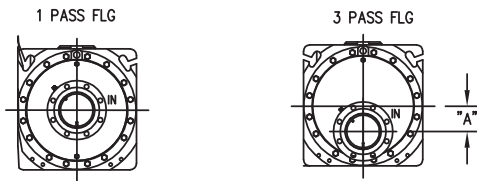

COMPRESSOR DISCHARGE END

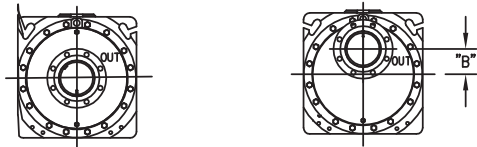

COMPRESSOR SUCTION END

WATERBOX FLANGE DETAIL

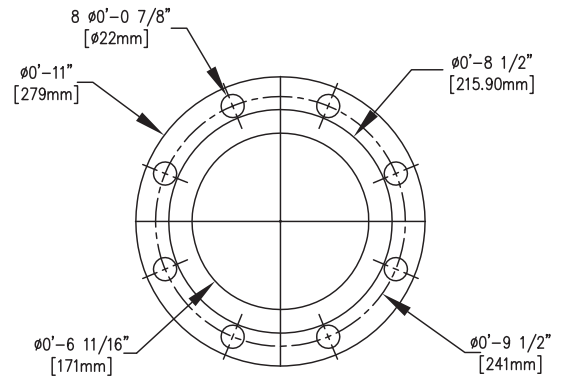

NIH EVAPORATOR

30XW UNIT SIZE	NUMBER OF PASSES	VICTAULIC		
		A in. (mm)	B in. (mm)	CONNECTION SIZE, in. (mm)
150-200	2	5 ⁹ / ₁₆ (142)	5 ⁹ / ₁₆ (142)	6 (152)
	1	—	—	—
	3	—	—	—

30XW UNIT SIZE	NUMBER OF PASSES	FLANGE		
		A in. (mm)	B in. (mm)	CONNECTION SIZE, in. (mm)
150-200	2	4 ¹³ / ₁₆ (122)	4 ¹³ / ₁₆ (122)	6 (152)
	1	0 (0)	0 (0)	6 (152)
	3	4 ¹¹ / ₁₆ (119)	4 ¹¹ / ₁₆ (119)	6 (152)

MARINE EVAPORATOR

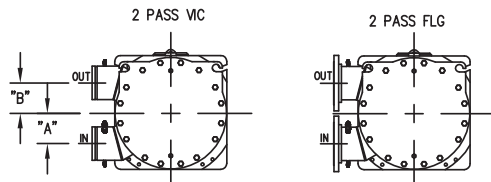

COMPRESSOR DISCHARGE END

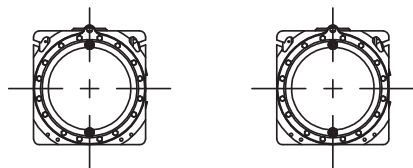

COMPRESSOR SUCTION END

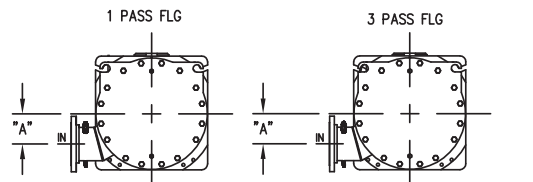

COMPRESSOR DISCHARGE END

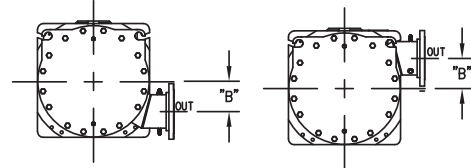

COMPRESSOR SUCTION END

MARINE EVAPORATOR

30XW UNIT SIZE	NUMBER OF PASSES	A in. (mm)	B in. (mm)	CONNECTION SIZE, in. (mm)
150-200	2	6 (152)	6 (152)	6 (152)
	1*	6 (152)	6 (152)	6 (152)
	3*	6 (152)	6 (152)	6 (152)

*Flange only. Not available on Victaulic.

30XW150-200 UNIT DIMENSIONS (cont)

NIH CONDENSER

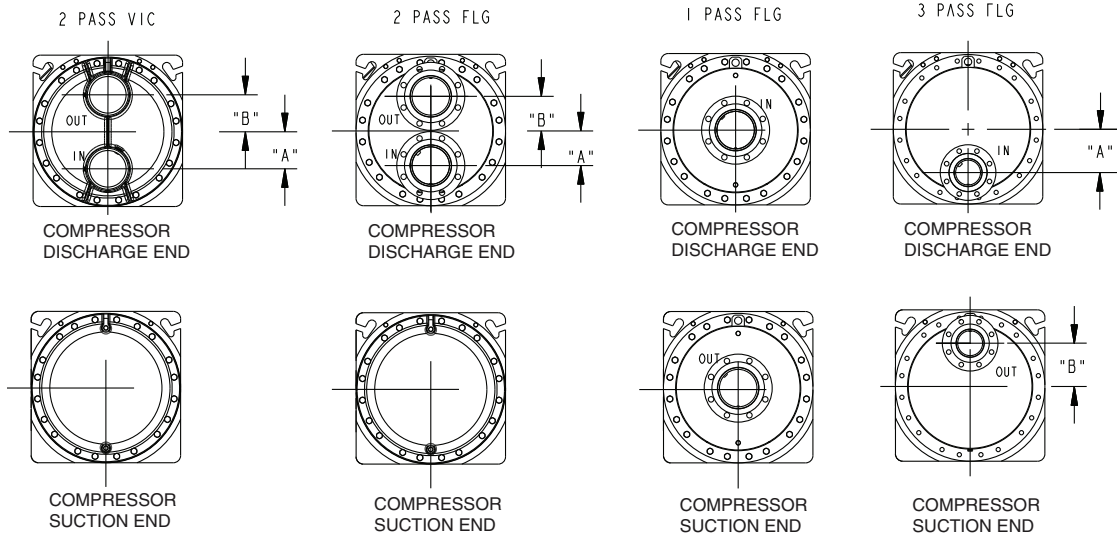

30XW UNIT SIZE	NUMBER OF PASSES	A in. (mm)	B in. (mm)	CONNECTION SIZE, in. (mm)
150-200	2	6 (152)	5 ⁵ / ₈ (142)	6 (152)
	1*	0 (0)	0 (0)	6 (152)
	3*	7 (178)	7 (178)	4 (102)

*Flange only. Not available on Victaulic.

MARINE CONDENSER

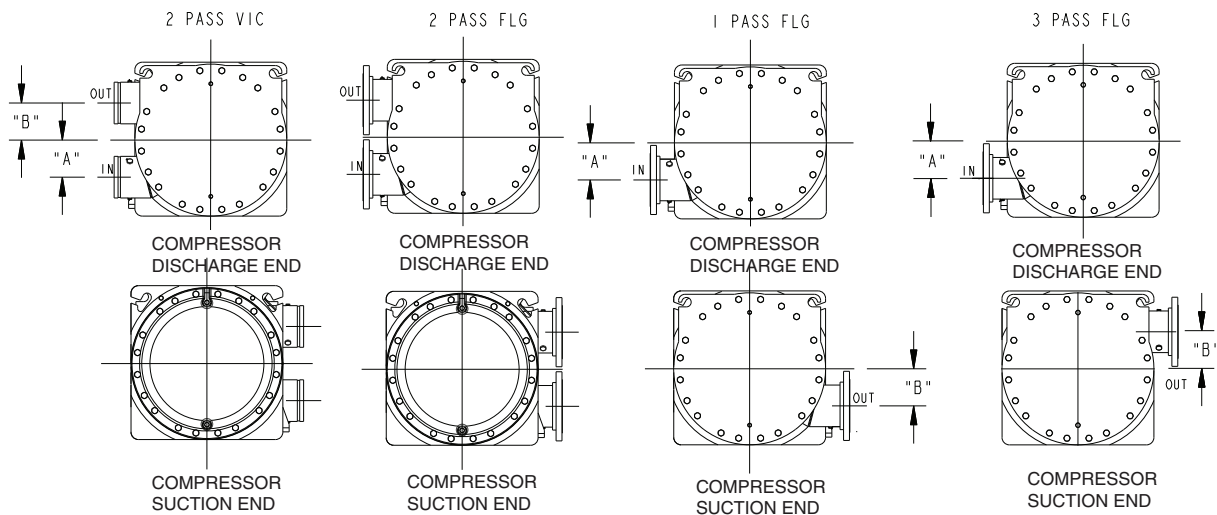

30XW UNIT SIZE	NUMBER OF PASSES	A in. (mm)	B in. (mm)	CONNECTION SIZE, in. (mm)
150-200	2	5 ⁷ / ₈ (149)	5 ⁷ / ₈ (149)	6 (152)
	1*	5 ⁷ / ₈ (149)	5 ⁷ / ₈ (149)	6 (152)
	3*	5 ⁷ / ₈ (149)	5 ⁷ / ₈ (149)	6 (152)

*Flange only. Not available on Victaulic.

30XW225-300 UNIT DIMENSIONS

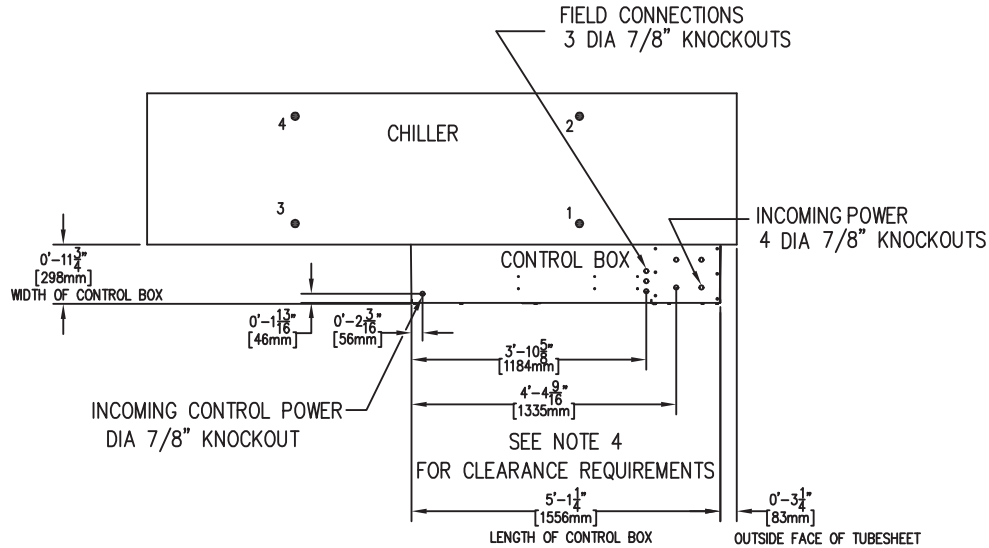

STANDARD 30XW225-300 UNIT DIMENSIONS

30XW UNIT SIZE	OPERATING WEIGHT		MOUNTING LOCATION WEIGHT							
			1		2		3		4	
	lb	kg	lb	kg	lb	kg	lb	kg	lb	kg
225	9,936	4506	1901	862	2390	1084	2501	1134	3144	1426
250	10,010	4541	1915	869	2408	1092	2520	1143	3168	1437
260	9,956	4516	1905	864	2395	1086	2506	1137	3151	1429
275	10,029	4549	1919	870	2412	1094	2524	1145	3174	1440
300	10,043	4557	1921	872	2416	1096	2528	1147	3178	1442

NOTE: Weights shown for standard chiller (2 pass with NIH, Victaulic waterboxes).

30XW225-300 UNIT AND WATERBOX SPECIFICATIONS

A	Evaporator Heat Exchanger Length — 9' - 8 15/16" [2970 mm]	C
B	Condenser Heat Exchanger Length — 9' - 8 15/16" [2970 mm]	D

Overall Length = Larger of A or B + 9' - 8 15/16" [2970] + larger of C or D, where:

A = evaporator discharge end waterbox length B = condenser discharge end waterbox length
 C = evaporator suction end waterbox length D = condenser suction end waterbox length

TYPE	WATERBOX ADDITIONAL LENGTH ADDERS				WATERBOX WEIGHT ADDERS			
	EVAP		COND		EVAP		COND	
	ft-in.	mm	ft-in.	mm	lb	kg	lb	kg
Return Cover	0-4 3/8	111	0-5 1/4	133	Std	Std	Std	Std
NIH 2 Pass Victaulic	0-7 7/16	189	0-8 1/2	216	Std	Std	Std	Std
NIH 2 Pass Flange	1-1 7/8	352	1-1 7/8	352	151	68.5	170	77.1
NIH 1 Pass Flange	1-1 7/8	352	1-1 7/8	352	224	101.6	268	121.6
NIH 3 Pass Flange	1-1 7/8	352	1-1 7/8	352	237	107.6	319	144.7
MWB 2 Pass Victaulic	1-4 5/16	414	1-4 5/16	414	278	126.1	285	129.3
MWB 2 Pass Flange	1-4 5/16	414	1-4 5/16	414	311	141.1	335	152.0
MWB 1 Pass Flange	1-4 5/16	414	1-4 5/16	414	600	272.2	607	275.3
MWB 3 Pass Flange	1-4 5/16	414	1-4 5/16	414	635	288.0	929	421.4

LEGEND

MWB — Marine Waterbox
NIH — Nozzle-In-Head

NOTES:

1. Add the additional weight to the standard unit operating weight to find the total weight of the unit.
2. ● Denotes center of gravity.
3. Dimensions shown in ft-in. [mm] unless noted.
4. The recommended service clearance for the machine is 3 ft [914 mm] at the front and rear, 2 ft [610 mm] at the top, and the tube length at one end and 3 ft [914 mm] at the opposite end. Consult local electrical codes for minimum clearance requirements on control panel side.
5. Victaulic nozzles are standard on all units. A flow switch is factory-installed in evaporator inlet Victaulic nozzle.
6. Maximum fluid side pressure of condenser or evaporator is 150 psig [1034 kPa] (standard) or 300 psig [2068 kPa] (optional).
7. Operating weight includes weight of water, refrigerant, and oil.

30XW225-300 UNIT DIMENSIONS (cont)

FRONT VIEW — DISCHARGE END

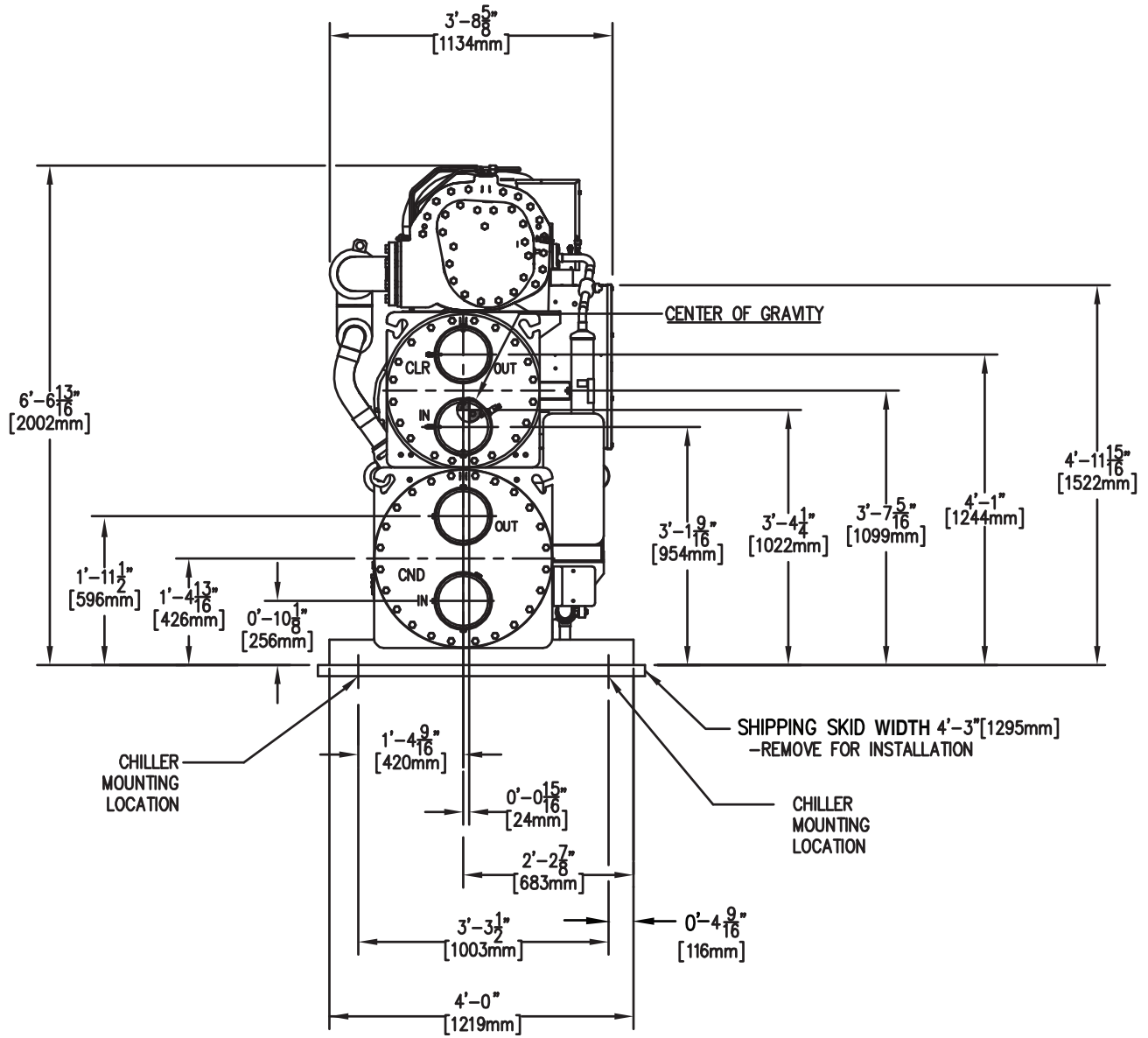

30XW225-300 UNIT DIMENSIONS (cont)

SIDE VIEW

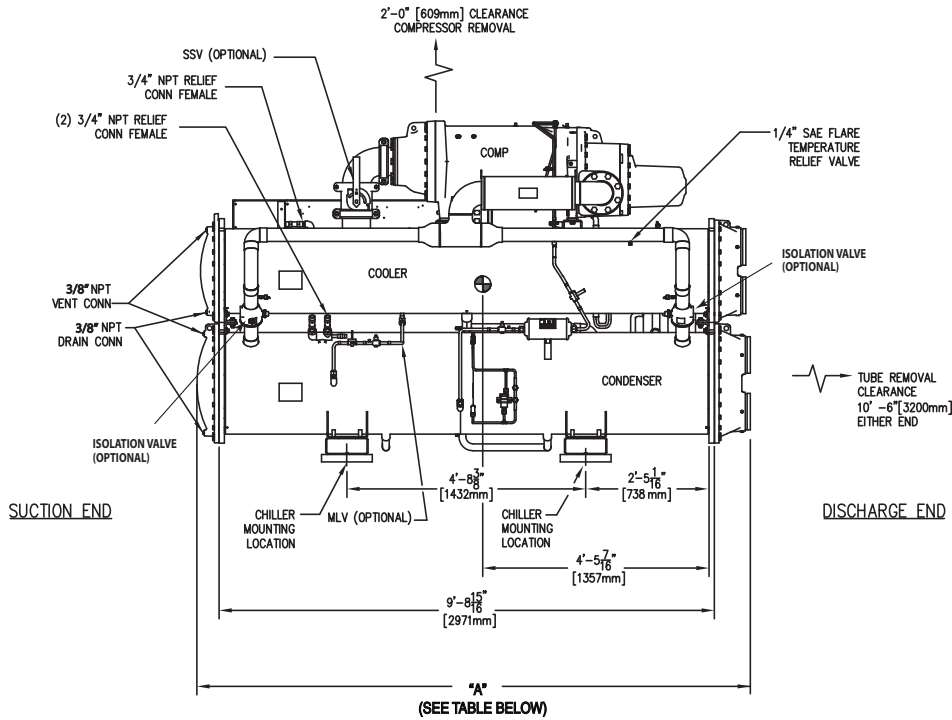

CHILLER DIMENSIONS

CONNECTION	PASSES COOLER / COND	WATER BOX COOLER/ COND	PRESSURE PSIG	NOZZLE TYPE	"A" ft-in. [mm]	ADDED WGT lb [kg]
STD ENDS	2P / 2P	NIH / NIH	150 or 300	VIC	10-10 11/16 [3320]	0
STD ENDS	2P / 2P	NIH / NIH	150 or 260	FLG	11-4 5/16 [3463]	320 [145]
STD ENDS	2P / 2P	NIH / MWB	150 or 300	VIC	11-6 9/16 [3519]	285 [129]
STD ENDS	2P / 2P	NIH / MWB	150 or 260	FLG	11-6 9/16 [3519]	335 [152]
STD ENDS	2P / 2P	MWB / NIH	150 or 300	VIC	11-6 9/16 [3519]	278 [126]
STD ENDS	2P / 2P	MWB / NIH	150 or 260	FLG	11-6 9/16 [3519]	311 [141]
STD ENDS	2P / 2P	MWB / MWB	150 or 300	VIC	11-6 9/16 [3519]	563 [255]
STD ENDS	2P / 2P	MWB / MWB	150 or 260	FLG	11-6 9/16 [3519]	646 [293]
STD ENDS	2P / 3P	NIH / NIH	150 or 260	FLG	12-0 1/2 [3670]	470 [213]
STD ENDS	2P / 3P	NIH / MWB	150 or 260	FLG	12-5 5/8 [3800]	1080 [490]
OPP ENDS	1P / 1P	NIH / NIH	150 or 260	FLG	12-0 11/16 [3676]	492 [223]
OPP ENDS	1P / 1P	NIH / MWB	150 or 260	FLG	12-5 5/8 [3800]	831 [377]
OPP ENDS	1P / 1P	MWB / NIH	150 or 260	FLG	12-5 5/8 [3800]	768 [394]
OPP ENDS	1P / 1P	MWB / MWB	150 or 260	FLG	12-5 5/8 [3800]	1207 [547]
OPP ENDS	2P / 2P	NIH / NIH	150 or 300	VIC	10-10 11/16 [3320]	0
OPP ENDS	2P / 2P	NIH / NIH	150 or 260	FLG	11-4 5/16 [3463]	320 [145]
OPP ENDS	2P / 2P	NIH / MWB	150 or 300	VIC	11-6 9/16 [3519]	285 [129]
OPP ENDS	2P / 2P	NIH / MWB	150 or 260	FLG	11-6 9/16 [3519]	335 [152]
OPP ENDS	2P / 2P	MWB / NIH	150 or 300	VIC	11-6 9/16 [3519]	278 [126]
OPP ENDS	2P / 2P	MWB / NIH	150 or 260	FLG	11-6 9/16 [3519]	311 [141]
OPP ENDS	2P / 2P	MWB / MWB	150 or 300	VIC	11-6 9/16 [3519]	563 [255]
OPP ENDS	2P / 2P	MWB / MWB	150 or 260	FLG	11-6 9/16 [3519]	646 [293]
OPP ENDS	3P / 1P	NIH / NIH	150 or 260	FLG	12-0 11/16 [3676]	505 [229]
OPP ENDS	3P / 1P	NIH / MWB	150 or 260	FLG	12-5 5/8 [3800]	844 [383]
OPP ENDS	3P / 1P	MWB / NIH	150 or 260	FLG	12-5 5/8 [3800]	903 [410]
OPP ENDS	3P / 1P	MWB / MWB	150 or 260	FLG	12-5 5/8 [3800]	1242 [470]

LEGEND

- 1P — 1 Pass
- 2P — 2 Pass
- 3P — 3 Pass
- MLV — Minimum Load Value
- NIH — Nozzle-In-Head
- OPP ENDS — Opposite Ends
- SAE — Society of Automotive Engineers
- SSV — Suction Service Valve
- STD ENDS — Standard Ends
- VIC — Victaulic

30XW225-300 UNIT DIMENSIONS (cont)

NIH EVAPORATOR

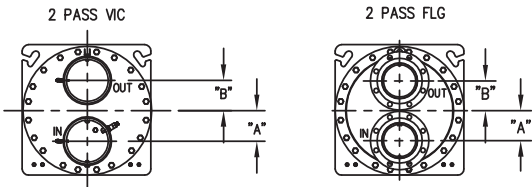

COMPRESSOR DISCHARGE END



COMPRESSOR SUCTION END

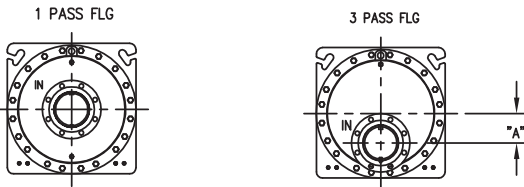

COMPRESSOR DISCHARGE END

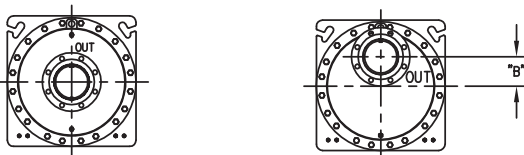

COMPRESSOR SUCTION END

WATERBOX FLANGE DETAIL

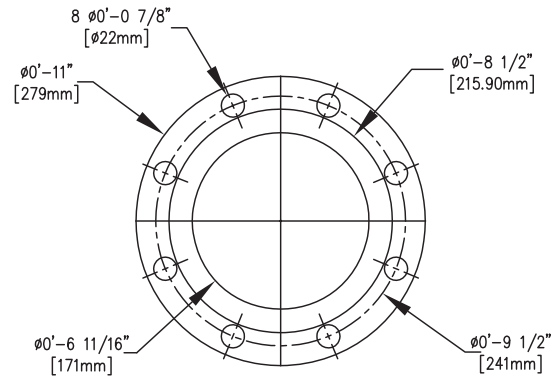

NIH EVAPORATOR

30XW UNIT SIZE	NUMBER OF PASSES	VICTAULIC		
		A in. (mm)	B in. (mm)	CONNECTION SIZE, in. (mm)
225-300	2	5 ¹¹ / ₁₆ (145)	5 ¹¹ / ₁₆ (145)	8 (203)
	1	—	—	—
	3	—	—	—

30XW UNIT SIZE	NUMBER OF PASSES	FLANGE		
		A in. (mm)	B in. (mm)	CONNECTION SIZE, in. (mm)
225-300	2	5 ⁵ / ₈ (142)	5 ⁵ / ₈ (142)	6 (152)
	1	0 (0)	0 (0)	6 (152)
	3	5 ¹ / ₂ (140)	5 ¹ / ₂ (140)	6 (152)

MARINE EVAPORATOR

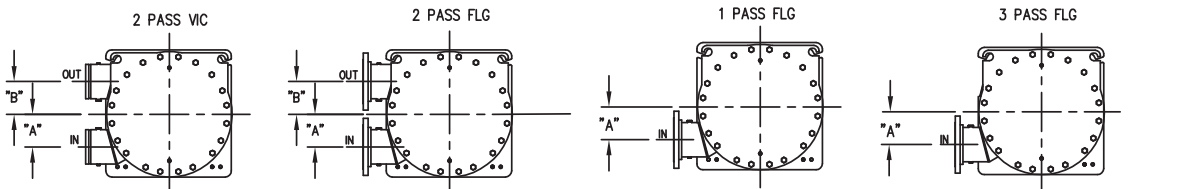

COMPRESSOR DISCHARGE END

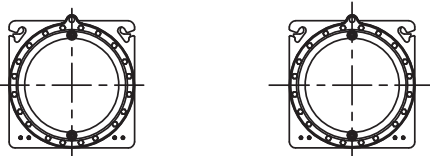

COMPRESSOR SUCTION END

COMPRESSOR DISCHARGE END

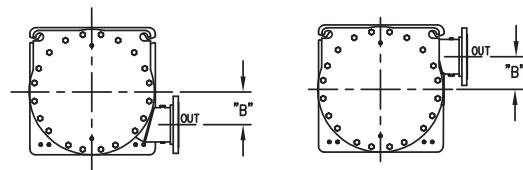

COMPRESSOR SUCTION END

MARINE EVAPORATOR

30XW UNIT SIZE	NUMBER OF PASSES	A in. (mm)	B in. (mm)	CONNECTION SIZE, in. (mm)
225-300	2	6 ⁵ / ₁₆ (160)	6 ⁵ / ₁₆ (160)	6 (152)
	1*	6 ⁵ / ₁₆ (160)	6 ⁵ / ₁₆ (160)	6 (152)
	3*	6 ⁵ / ₁₆ (160)	6 ⁵ / ₁₆ (160)	6 (152)

* Flange only. Not available on Victaulic.

30XW225-300 UNIT DIMENSIONS (cont)

NIH CONDENSER

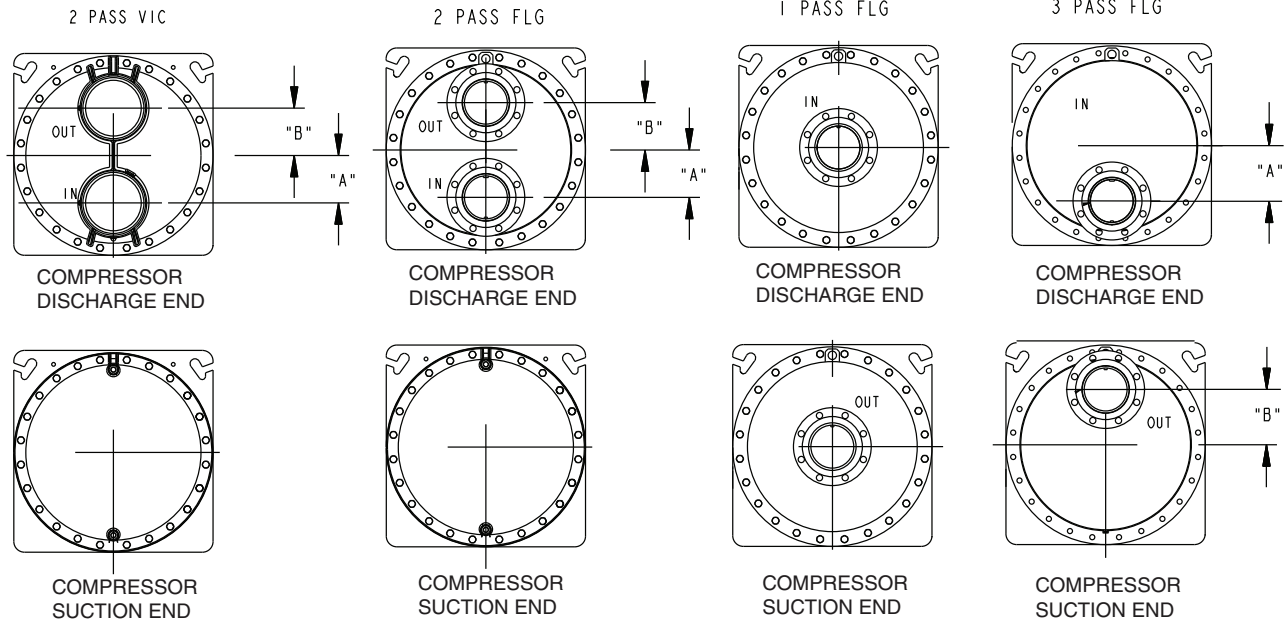

30XW UNIT SIZE	NUMBER OF PASSES	A in. (mm)	B in. (mm)	CONNECTION SIZE, in. (mm)	
				Flange	Victaulic
225-300	2	6 ¹¹ / ₁₆ (170)	6 ¹¹ / ₁₆ (170)	6 (152)	8 (203)
	1	0 (0)	0 (0)	6 (152)	—
	3	7 ³ / ₁₆ (198)	7 ³ / ₁₆ (198)	6 (152)	—

MARINE CONDENSER

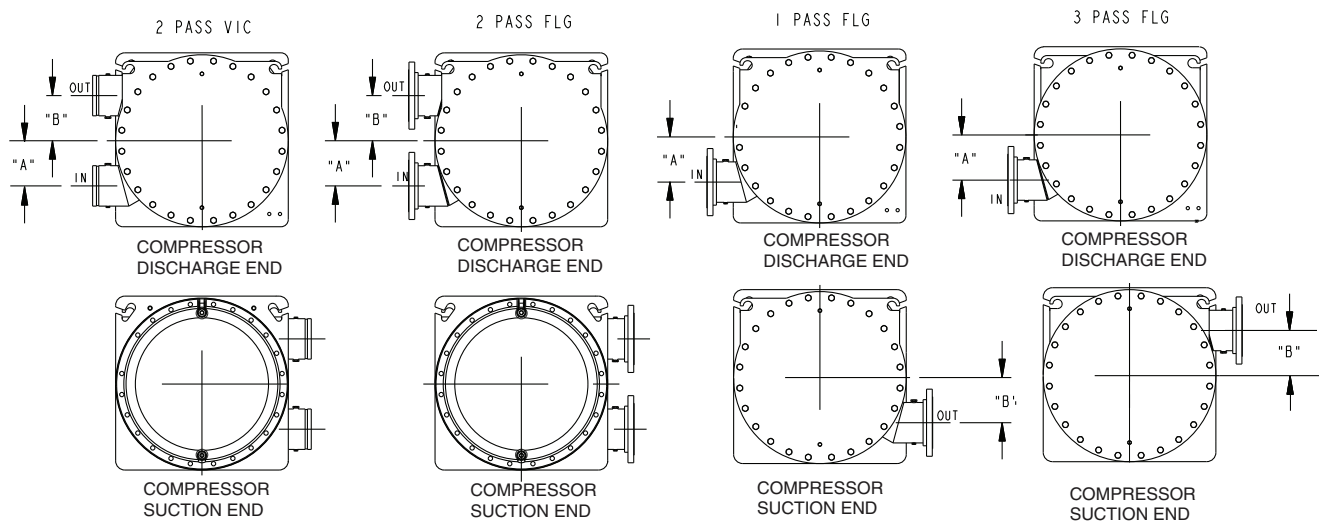

30XW UNIT SIZE	NUMBER OF PASSES	A in. (mm)	B in. (mm)	CONNECTION SIZE, in. (mm)
225-300	2	7 ³ / ₈ (188)	7 ³ / ₈ (188)	6 (152)
	1*	7 ³ / ₈ (188)	7 ³ / ₈ (188)	6 (152)
	3*	7 ³ / ₈ (188)	7 ³ / ₈ (188)	6 (152)

*Flange only. Not available on Victaulic.

30XW325-400 UNIT DIMENSIONS

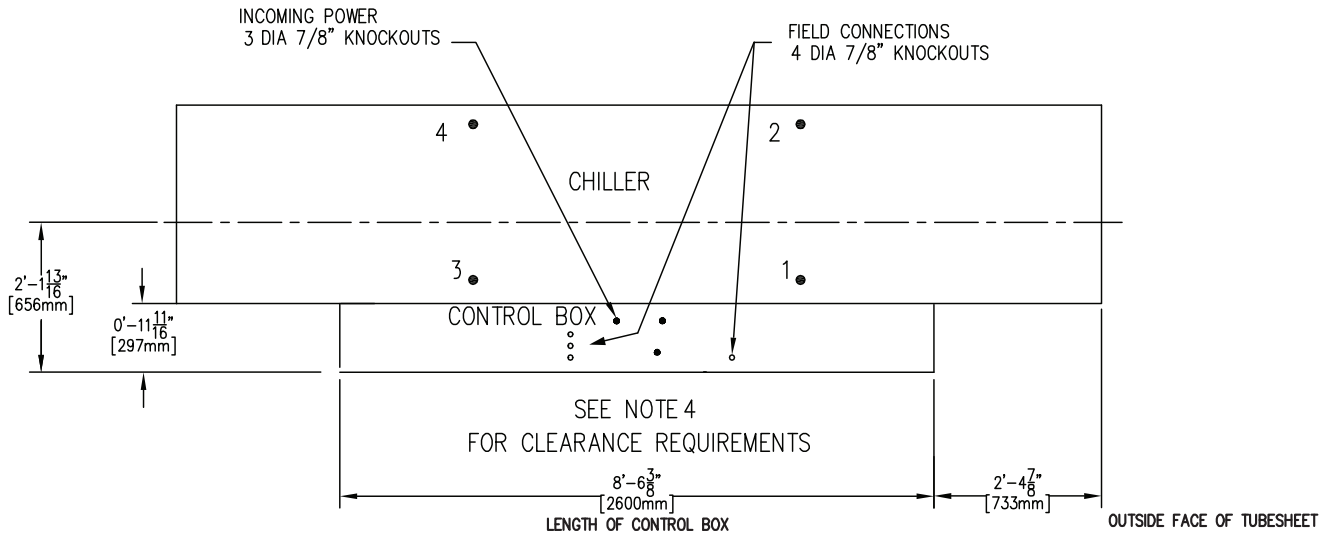

STANDARD 30XW325-400 UNIT DIMENSIONS

30XW UNIT SIZE	OPERATING WEIGHT		MOUNTING LOCATION WEIGHT							
			1		2		3		4	
	lb	kg	lb	kg	lb	kg	lb	kg	lb	kg
325	14,319	6495	3770	1710	3891	1765	3277	1486	3381	1534
350	14,515	6584	3822	1734	3944	1789	3322	1507	3428	1555
375	14,468	6563	3810	1728	3931	1783	3311	1502	3417	1550
400	14,759	6695	3886	1763	4010	1819	3378	1532	3485	1581

NOTE: Weights shown for standard chiller (2 pass with NIH, Victaulic waterboxes).

30XW325-400 UNIT AND WATERBOX SPECIFICATIONS

A	Evaporator Heat Exchanger Length — 12' - 2" [3708 mm]	C
B	Condenser Heat Exchanger Length — 12' - 2" [3708 mm]	D

Overall Length = Larger of A or B + 12' - 2" [3708] + larger of C or D, where:
 A = evaporator discharge end waterbox length B = condenser discharge end waterbox length
 C = evaporator suction end waterbox length D = condenser suction end waterbox length

TYPE	WATERBOX ADDITIONAL LENGTH ADDERS				WATERBOX WEIGHT ADDERS			
	EVAP		COND		EVAP		COND	
	ft-in.	mm	ft-in.	mm	lb	kg	lb	kg
Return Cover	0-4 7/8	124	0-5 1/4	133	Std	Std	Std	Std
NIH 2 Pass Victaulic	0-7 13/16	198	0-8 1/2	216	Std	Std	Std	Std
NIH 2 Pass Flange	1-0 5/8	321	1-1 7/8	352	158	71.7	174	78.9
NIH 1 Pass Flange	1-0 5/8	321	1-1 7/8	352	241	109.3	268	121.6
NIH 3 Pass Flange	1-0 5/8	321	1-1 7/8	N/A	253	114.8	318	144.2
MWB 2 Pass Victaulic	1-4 5/16	414	1-4 5/16	414	276	125.2	278	126.1
MWB 2 Pass Flange	1-4 5/16	414	1-4 5/16	414	355	161.0	362	164.2
MWB 1 Pass Flange	1-4 5/16	414	1-4 5/16	414	611	277.1	651	295.3
MWB 3 Pass Flange	1-4 5/16	414	1-4 5/16	414	657	298.0	928	420.9

LEGEND

MWB — Marine Waterbox
NIH — Nozzle-In-Head

NOTES:

- Add the additional weight to the standard unit operating weight to find the total weight of the unit.
- ⊙ Denotes center of gravity.
- Dimensions shown in ft-in. [mm] unless noted.
- The recommended service clearance for the machine is 3 ft [914 mm] at the front and rear, 2 ft [610 mm] at the top and the tube length at one end and 3 ft [914 mm] at the opposite end. Consult local electrical codes for minimum clearance requirements on control panel side.
- Victaulic nozzles are standard on all units. A flow switch is factory-installed in evaporator inlet Victaulic nozzle.
- Maximum fluid side pressure of condenser or evaporator is 150 psig [1034 kPa] (standard) or 300 psig [2068 kPa] (optional).
- Operating weight includes weight of water, refrigerant, and oil.

30XW325-400 UNIT DIMENSIONS (cont)

FRONT VIEW — DISCHARGE END

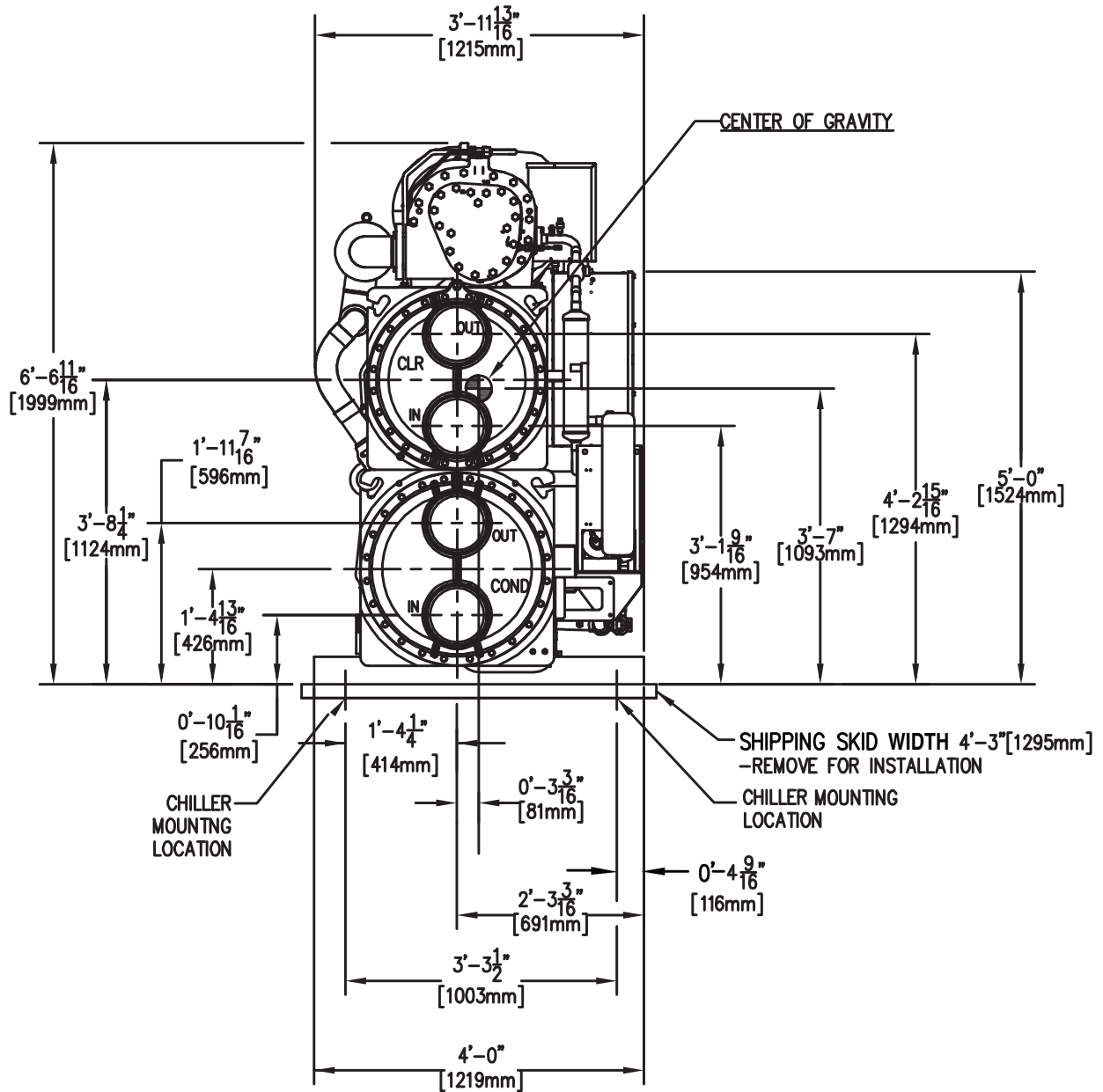

30XW325-400 UNIT DIMENSIONS (cont)

SIDE VIEW

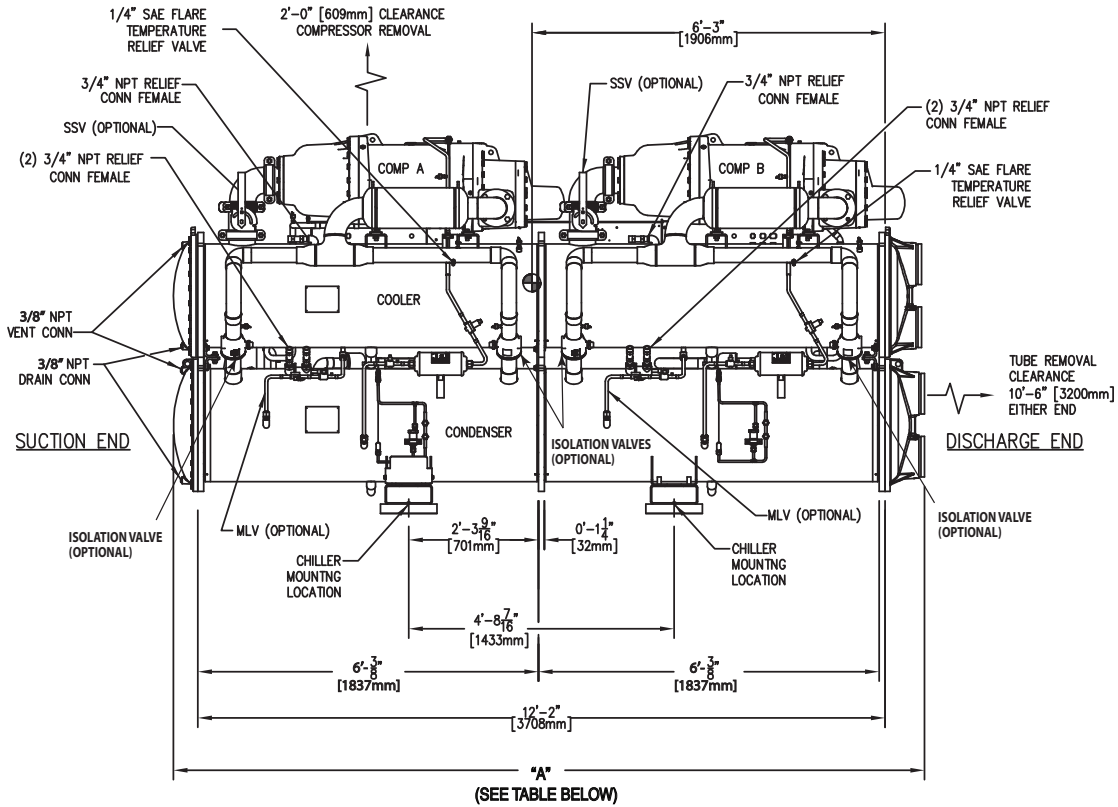

CHILLER DIMENSIONS

CONNECTION	PASSES COOLER/ COND	WATER BOX COOLER/ COND	PRESSURE PSIG	NOZZLE TYPE	"A" ft-in. [mm]	ADDED WGT lb [kg]
STD ENDS	2P / 2P	NIH / NIH	150 or 300	VIC	13-3 3/4 [4058]	0
STD ENDS	2P / 2P	NIH / NIH	150 or 260	FLG	13-9 1/16 [4193]	331 [150]
STD ENDS	2P / 2P	NIH / MWB	150 or 300	VIC	13-11 9/16 [4256]	278 [126]
STD ENDS	2P / 2P	NIH / MWB	150 or 260	FLG	13-11 9/16 [4256]	362 [164]
STD ENDS	2P / 2P	MWB / NIH	150 or 300	VIC	13-11 9/16 [4256]	276 [125]
STD ENDS	2P / 2P	MWB / NIH	150 or 260	FLG	13-11 9/16 [4256]	355 [161]
STD ENDS	2P / 2P	MWB / MWB	150 or 300	VIC	13-11 9/16 [4256]	555 [252]
STD ENDS	2P / 2P	MWB / MWB	150 or 260	FLG	13-11 9/16 [4256]	717 [325]
STD ENDS	2P / 3P	NIH / NIH	150 or 260	FLG	14-5 9/16 [4406]	476 [216]
STD ENDS	2P / 3P	NIH / MWB	150 or 260	FLG	14-10 9/16 [4535]	1086 [493]
OPP ENDS	1P / 1P	NIH / NIH	150 or 260	FLG	14-5 5/8 [4410]	509 [231]
OPP ENDS	1P / 1P	NIH / MWB	150 or 260	FLG	14-10 9/16 [4535]	892 [405]
OPP ENDS	1P / 1P	MWB / NIH	150 or 260	FLG	14-10 9/16 [4535]	880 [399]
OPP ENDS	1P / 1P	MWB / MWB	150 or 260	FLG	14-10 9/16 [4535]	1262 [572]
OPP ENDS	2P / 2P	NIH / NIH	150 or 300	VIC	13-3 3/4 [4058]	0
OPP ENDS	2P / 2P	NIH / NIH	150 or 260	FLG	13-9 1/16 [4193]	331 [150]
OPP ENDS	2P / 2P	NIH / MWB	150 or 300	VIC	13-11 9/16 [4256]	278 [126]
OPP ENDS	2P / 2P	NIH / MWB	150 or 260	FLG	13-11 9/16 [4256]	362 [164]
OPP ENDS	2P / 2P	MWB / NIH	150 or 300	VIC	13-11 9/16 [4256]	276 [125]
OPP ENDS	2P / 2P	MWB / NIH	150 or 260	FLG	13-11 9/16 [4256]	355 [161]
OPP ENDS	2P / 2P	MWB / MWB	150 or 300	VIC	13-11 9/16 [4256]	555 [252]
OPP ENDS	2P / 2P	MWB / MWB	150 or 260	FLG	13-11 9/16 [4256]	717 [325]
OPP ENDS	3P / 1P	NIH / NIH	150 or 260	FLG	14-5 5/8 [4410]	521 [236]
OPP ENDS	3P / 1P	NIH / MWB	150 or 260	FLG	14-10 9/16 [4535]	904 [410]
OPP ENDS	3P / 1P	MWB / NIH	150 or 260	FLG	14-10 9/16 [4535]	925 [420]
OPP ENDS	3P / 1P	MWB / MWB	150 or 260	FLG	14-10 9/16 [4535]	1308 [593]

LEGEND

- 1P — 1 Pass
- 2P — 2 Pass
- 3P — 3 Pass
- FLG — Flange
- MLV — Minimum Load Valve
- MWB — Marine Water Box
- NIH — Nozzle-In-Head
- OPP ENDS — Opposite Ends
- SAE — Society of Automotive Engineers
- SSV — Suction Service Valve
- STD ENDS — Standard Ends
- VIC — Victaulic

30XW325-400 UNIT DIMENSIONS (cont)

NIH EVAPORATOR

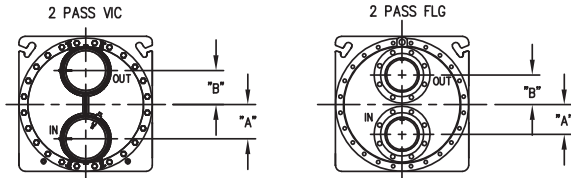

COMPRESSOR DISCHARGE END



COMPRESSOR SUCTION END

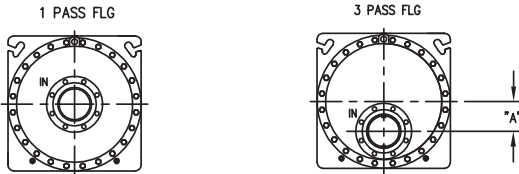

COMPRESSOR DISCHARGE END

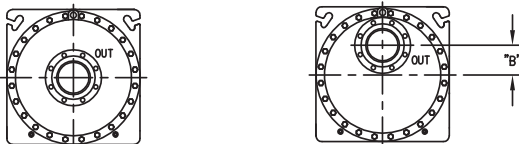

COMPRESSOR SUCTION END

WATERBOX FLANGE DETAIL

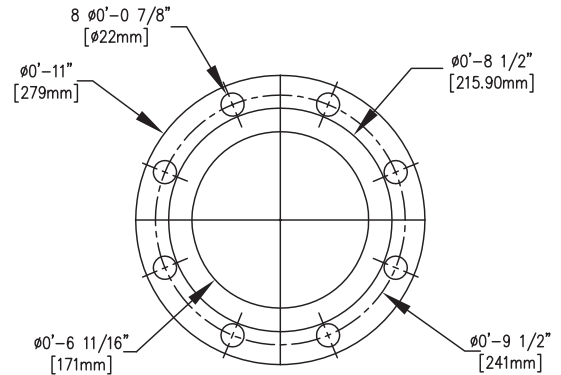

NIH EVAPORATOR

30XW UNIT SIZE	NUMBER OF PASSES	VICTAULIC		
		A in. (mm)	B in. (mm)	CONNECTION SIZE, in. (mm)
325-400	2	6 ¹¹ / ₁₆ (170)	6 ¹¹ / ₁₆ (170)	8 (203)
	1	—	—	—
	3	—	—	—

30XW UNIT SIZE	NUMBER OF PASSES	FLANGE		
		A in. (mm)	B in. (mm)	CONNECTION SIZE, in. (mm)
325-400	2	5 ¹³ / ₁₆ (148)	5 ¹³ / ₁₆ (148)	6 (152)
	1	0 (0)	0 (0)	6 (152)
	3	5 ¹³ / ₁₆ (148)	5 ¹³ / ₁₆ (148)	6 (152)

MARINE EVAPORATOR

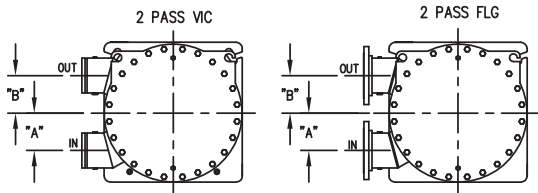

COMPRESSOR DISCHARGE END

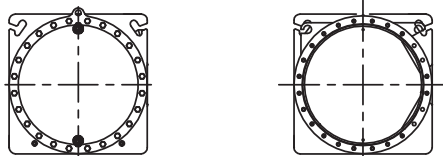

COMPRESSOR SUCTION END

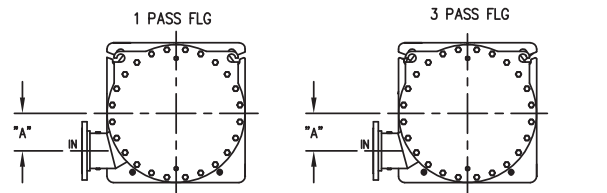

COMPRESSOR DISCHARGE END

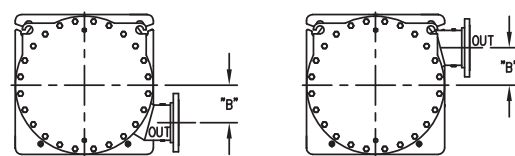

COMPRESSOR SUCTION END

MARINE EVAPORATOR

30XW UNIT SIZE	NUMBER OF PASSES	A in. (mm)	B in. (mm)	CONNECTION SIZE, in. (mm)
325-400	2	7 ¹ / ₈ (180)	7 ¹ / ₈ (180)	6 (152)
	1*	7 ¹ / ₈ (180)	7 ¹ / ₈ (180)	6 (152)
	3*	7 ¹ / ₈ (180)	7 ¹ / ₈ (180)	6 (152)

*Flange only. Not available on Victaulic.

30XW325-400 UNIT DIMENSIONS (cont)

NIH CONDENSER

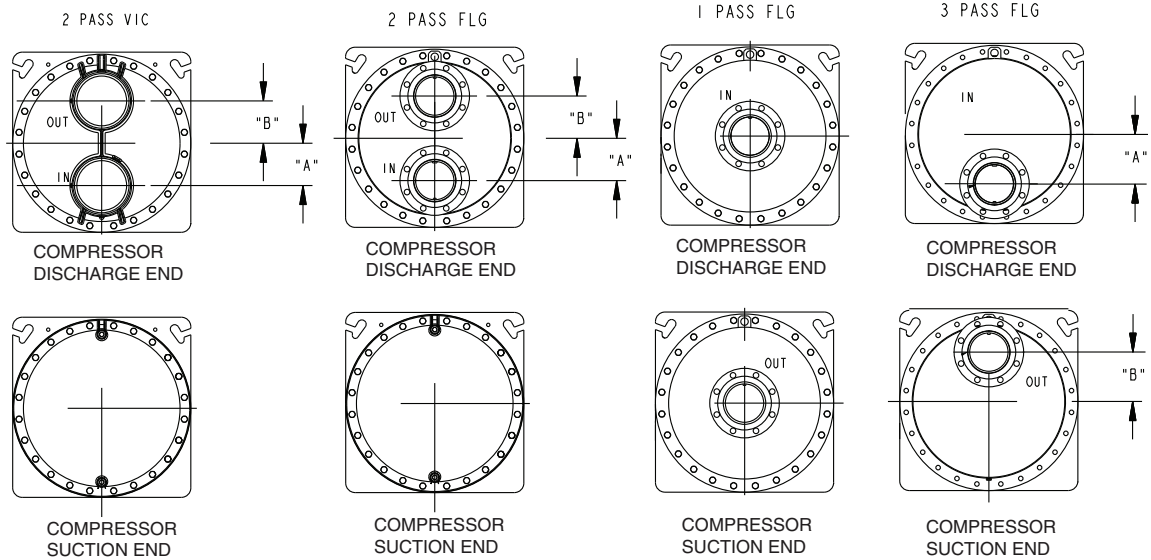

30XW UNIT SIZE	NUMBER OF PASSES	A in. (mm)	B in. (mm)	CONNECTION SIZE, in. (mm)	
				Flange	Victaulic
325-400	2	6 ¹ / ₁₆ (170)	6 ¹ / ₁₆ (170)	6 (152)	8 (203)
	1	0 (0)	0 (0)	6 (152)	—
	3	7 ³ / ₁₆ (198)	7 ³ / ₁₆ (198)	6 (152)	—

MARINE CONDENSER

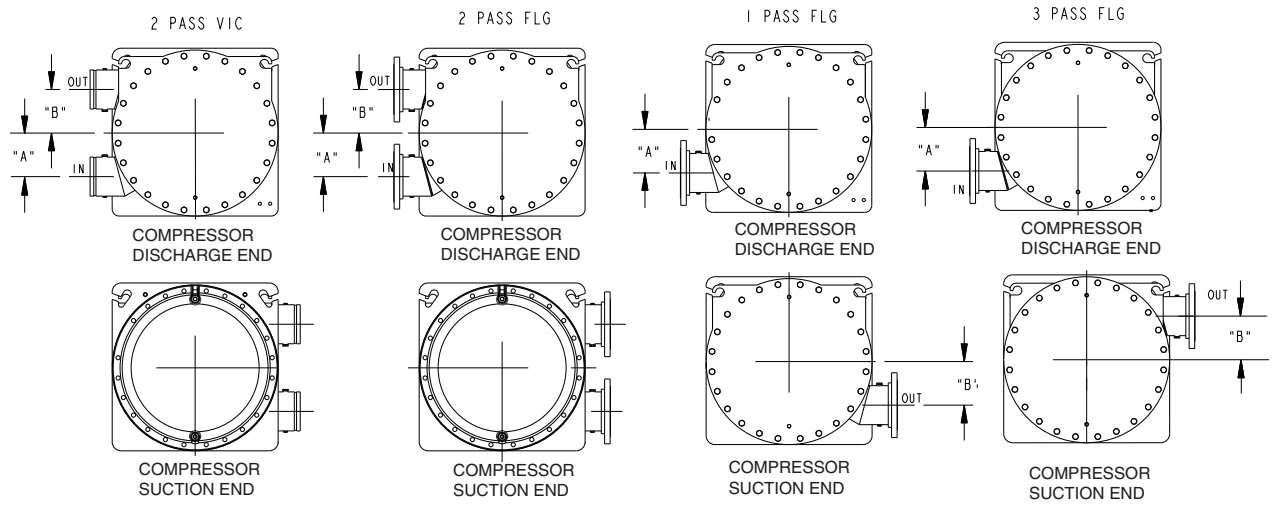

30XW UNIT SIZE	NUMBER OF PASSES	A in. (mm)	B in. (mm)	CONNECTION SIZE, in. (mm)
325-400	2	7 ³ / ₈ (188)	7 ³ / ₈ (188)	6 (152)
	1*	7 ³ / ₈ (188)	7 ³ / ₈ (188)	6 (152)
	3*	7 ³ / ₈ (188)	7 ³ / ₈ (188)	6 (152)

* Flange only. Not available on Victaulic.

Selection procedure



Carrier's packaged selection program provides a quick, easy selection of Carrier's water-cooled chillers. The program considers specific temperature, fluid and flow requirements among other factors such as fouling and altitude corrections.

Before selecting a chiller, consider the following points:

Leaving water (fluid) temperature (LWT)

- The LWT must be at least 40°F (4.4°C) or greater.
- If the LWT is less than 40°F (4.4°C), loop freeze protection to a minimum of 15°F (8.3°C) below the LWT set point is required. The medium temperature brine option is also required.
- If the LWT requirement is greater than 60°F (15.5°C), a mixing loop is required.

Entering water (fluid) temperature (EWT)

- If the EWT requirement is greater than 70°F (21.1°C), a mixing loop is required. The EWT should not exceed 70°F (21.1°C) for extended operation. Pulldown can be accomplished from 95°F (35°C).

Evaporator flow rate or evaporator delta-T:

- The evaporator delta-T (EWT – LWT) must fall between 5 and 20°F (2.8 and 11.1°C) while still meeting the maximum entering requirements.
- For larger or smaller delta-T applications, a mixing loop is required. If the evaporator flow is variable, the rate of change of flow should not exceed 10% per minute. The loop volume in circulation must equal or exceed 3 gallons per nominal ton (3.2 L per kW) of cooling for temperature stability and accuracy in normal air conditioning applications. In process cooling applications, there should be 6 to 10 gallons per ton (6.5 to 10.8 L per kW). To achieve this loop volume, it is often necessary to install a tank in the loop. The tank should be baffled to ensure there is no stratification, and that water (or brine) entering the tank is adequately mixed

with liquid in the tank. See Water Loop Volume in the Application Data section on page 45.

Evaporator pressure drop:

- A high evaporator pressure drop can be expected when the evaporator delta-T is low. A mixing loop can help to alleviate this situation.
- The three-pass evaporator option is recommended to increase performance when the evaporator delta T is high. This is particularly helpful with brine applications.

Condenser pressure drop:

- A high condenser pressure drop can be expected when the condenser delta-T is low. A one-pass condenser can help lower pressure drop.

Series chillers:

- One-pass heat exchangers can help lower pressure drop when heat exchangers are placed in series.

Water quality, fouling factor:

- Poor water quality can increase the required evaporator fouling factor.
- Higher than standard fouling factors lead to lower capacity and higher input kW from a given chiller size compared to running the same application with better water quality (and lower fouling factors).

Temperature reset:

- Return water (standard)
- Outside air temperature (accessory sensor required)
- Space temperature (accessory sensor required)
- 4 to 20 mA (requires an energy management module)

Demand limit:

- 2-step (requires an energy management module)
- 4 to 20 mA (requires an energy management module)
- CCN Loadshed

EVAPORATOR AND CONDENSER FLOW RATES

30XW UNIT		EVAPORATOR				CONDENSER				NOMINAL			
		Leaving Fluid/Entering Fluid				Leaving Fluid/Entering Fluid				Evaporator		Condenser	
		Minimum		Maximum		Minimum		Maximum*					
		40°F (4.4°C)/ 45°F (7.2°C)		60°F (15.6°C)/ 70°F (21.1°C)		70°F (21.1°C)/ 65°F (18.3°C)		118°F (47.8°C)/ 110°F (43.3°C)					
		Minimum Flow Rate		Maximum Flow Rate		Minimum Flow Rate		Maximum Flow Rate		Nominal Flow Rate		Nominal Flow Rate	
		GPM	L/s	GPM	L/s	GPM	L/s	GPM	L/s	GPM	L/s	GPM	L/s
150	Two pass	200	12.6	720	45.4	240	15.1	960	60.6	384	24.2	480	30.3
	One pass	384	24.2	1520	95.9	480	30.3	1600	100.9	384	24.2	480	30.3
	Three pass	120	7.6	480	30.3	160	10.1	528	33.3	384	24.2	480	30.3
175	Two pass	213	13.4	765	48.3	255	16.1	1021	64.4	408	25.8	510	32.2
	One pass	408	25.8	1616	102.0	510	32.2	1701	107.3	408	25.8	510	32.2
	Three pass	128	8.0	510	32.2	170	10.7	561	35.4	408	25.8	510	32.2
185	Two pass	223	14.1	802	50.6	267	16.9	1069	67.5	428	27.0	535	33.7
	One pass	428	27.0	1693	106.8	535	33.7	1782	112.4	428	27.0	535	33.7
	Three pass	134	8.4	535	33.7	178	11.2	588	37.1	428	27.0	535	33.7
200	Two pass	239	15.1	860	54.3	287	18.1	1147	72.3	459	28.9	573	36.2
	One pass	459	28.9	1815	114.5	573	36.2	1911	120.6	459	28.9	573	36.2
	Three pass	143	9.0	573	36.2	191	12.1	631	39.8	459	28.9	573	36.2
225	Two pass	278	17.5	1001	63.2	334	21.1	1335	84.2	534	33.7	668	42.1
	One pass	534	33.7	2114	133.4	668	42.1	2225	140.4	534	33.7	668	42.1
	Three pass	167	10.5	668	42.1	223	14.0	734	46.3	543	33.7	668	42.1
250	Two pass	301	19.0	1085	68.4	362	22.8	1447	91.3	579	36.5	723	45.6
	One pass	579	36.5	2290	144.5	723	45.6	2411	152.1	579	36.5	723	45.6
	Three pass	181	11.4	723	45.6	241	15.2	796	50.2	579	36.5	723	45.6
260	Two pass	306	19.3	1102	69.5	367	23.2	1469	92.7	588	37.1	734	46.3
	One pass	588	37.1	2326	146.7	734	46.3	2448	154.4	588	37.1	734	46.3
	Three pass	184	11.6	734	46.3	245	15.4	808	51.0	588	37.1	734	46.3
275	Two pass	329	20.7	1183	74.6	394	24.9	1577	99.5	631	39.8	788	49.7
	One pass	631	39.8	2497	157.5	788	49.7	2628	165.8	631	39.8	788	49.7
	Three pass	197	12.4	788	49.7	263	16.6	867	54.7	631	39.8	788	49.7
300	Two pass	357	22.5	1285	81.1	428	27.0	1713	108.1	685	43.2	857	54.0
	One pass	685	43.2	2712	171.1	857	54.0	2855	180.1	685	43.2	857	54.0
	Three pass	214	13.5	857	54.0	286	18.0	942	59.4	685	43.2	857	54.0
325	Two pass	403	25.4	1450	91.4	483	30.5	1933	122.0	773	48.8	967	61.0
	One pass	773	48.8	3061	193.0	967	61.0	3222	203.3	773	48.8	967	61.0
	Three pass	242	15.2	967	61.0	322	20.3	1063	67.1	773	48.8	967	61.0
350	Two pass	429	27.0	1544	97.4	515	32.5	2058	129.8	823	51.9	1029	64.9
	One pass	823	51.9	3259	205.6	1029	64.9	3430	216.4	823	51.9	1029	64.9
	Three pass	257	16.2	1029	64.9	343	21.6	1132	71.4	823	51.9	1029	64.9
375	Two pass	455	28.7	1639	103.4	546	34.5	2186	137.9	874	55.2	1093	69.0
	One pass	874	55.2	3461	218.3	1093	69.0	3643	229.8	874	55.2	1093	69.0
	Three pass	273	17.2	1093	69.0	364	23.0	1202	75.8	874	55.2	1093	69.0
400	Two pass	481	30.4	1733	109.3	578	36.4	2310	145.7	924	58.3	1155	72.9
	One pass	924	58.3	3658	230.8	1155	72.9	3850	242.9	924	58.3	1155	72.9
	Three pass	289	18.2	1155	72.9	385	24.3	1271	80.2	924	58.3	1155	72.9

*Maximum condenser fluid temperature shown for standard condensing option. High condensing or heat machine option may have leaving fluid temperatures up to 140°F (60°C) and entering up to 128°F (53.3°C).

30XW150-200 EVAPORATOR MARINE WATERBOX

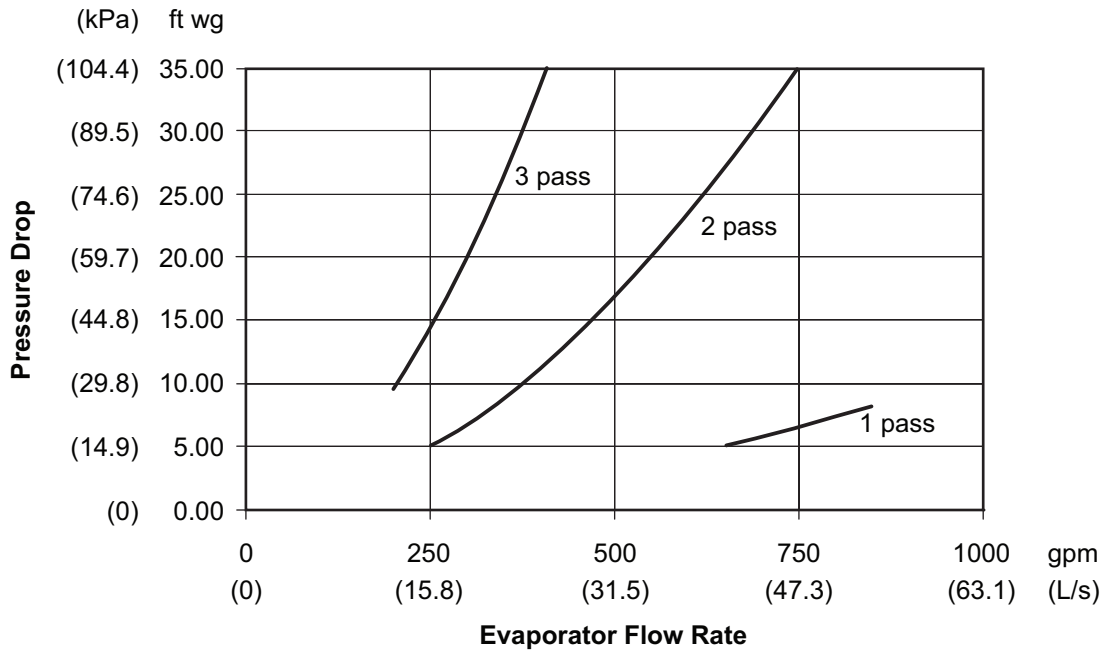

NOTE: The table above represents pressure drops only. The table does not imply that the chiller can be properly applied over the entire range of evaporator water flow rates represented. Pressure drop values are applicable to fresh water.

30XW225-300 EVAPORATOR MARINE WATERBOX

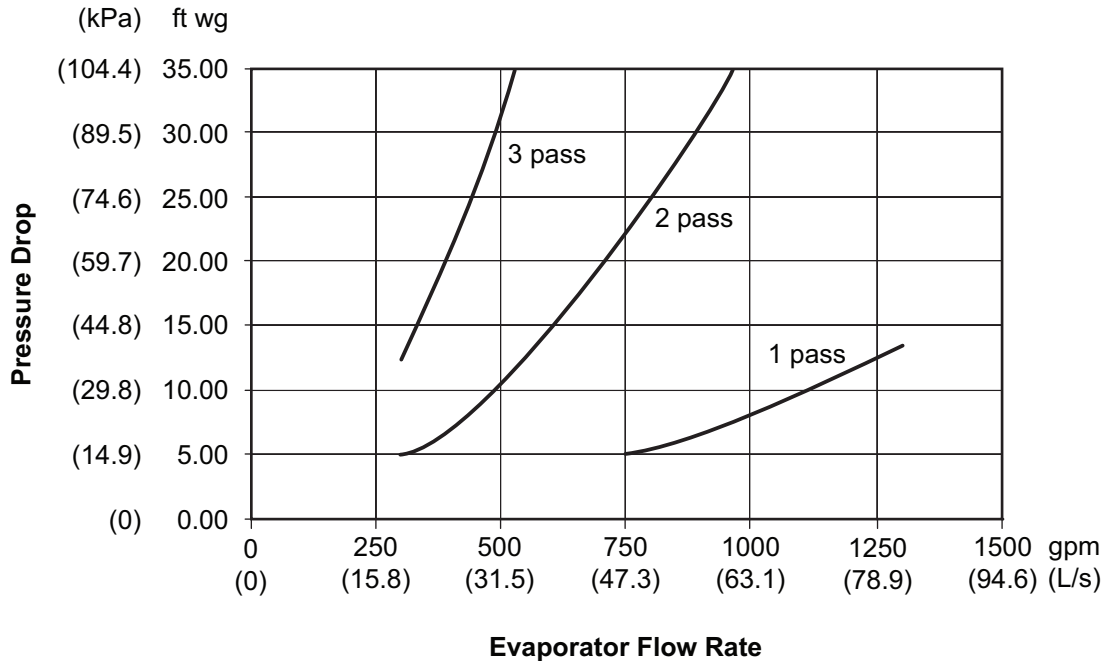

NOTE: The table above represents pressure drops only. The table does not imply that the chiller can be properly applied over the entire range of evaporator water flow rates represented. Pressure drop values are applicable to fresh water.

30XW325-400 EVAPORATOR MARINE WATERBOX

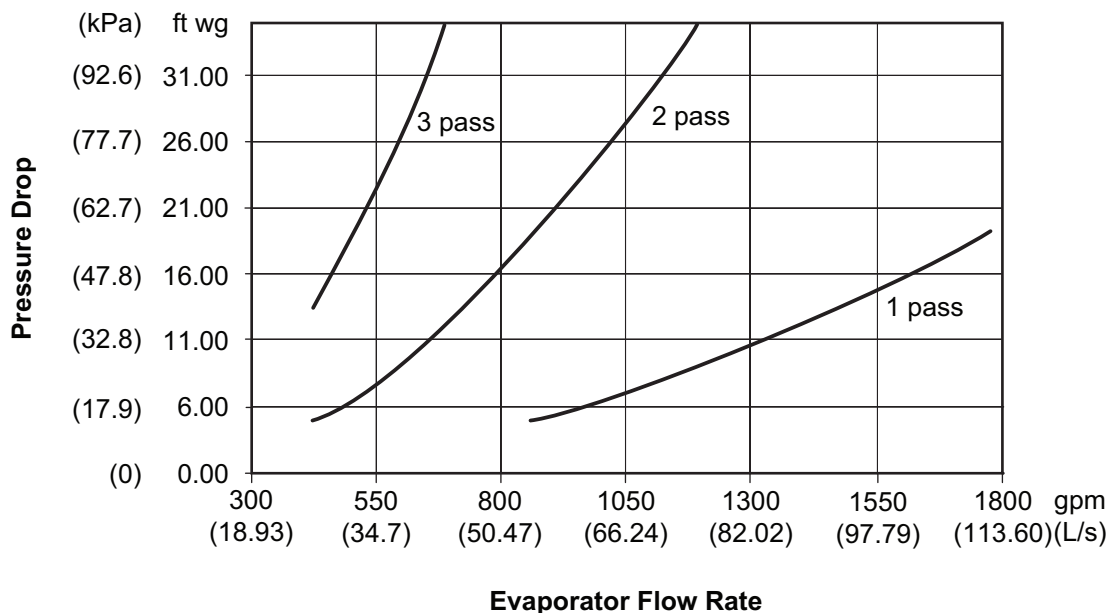

NOTE: The table above represents pressure drops only. The table does not imply that the chiller can be properly applied over the entire range of evaporator water flow rates represented. Pressure drop values are applicable to fresh water.

30XW150-200 EVAPORATOR NIH FLANGE

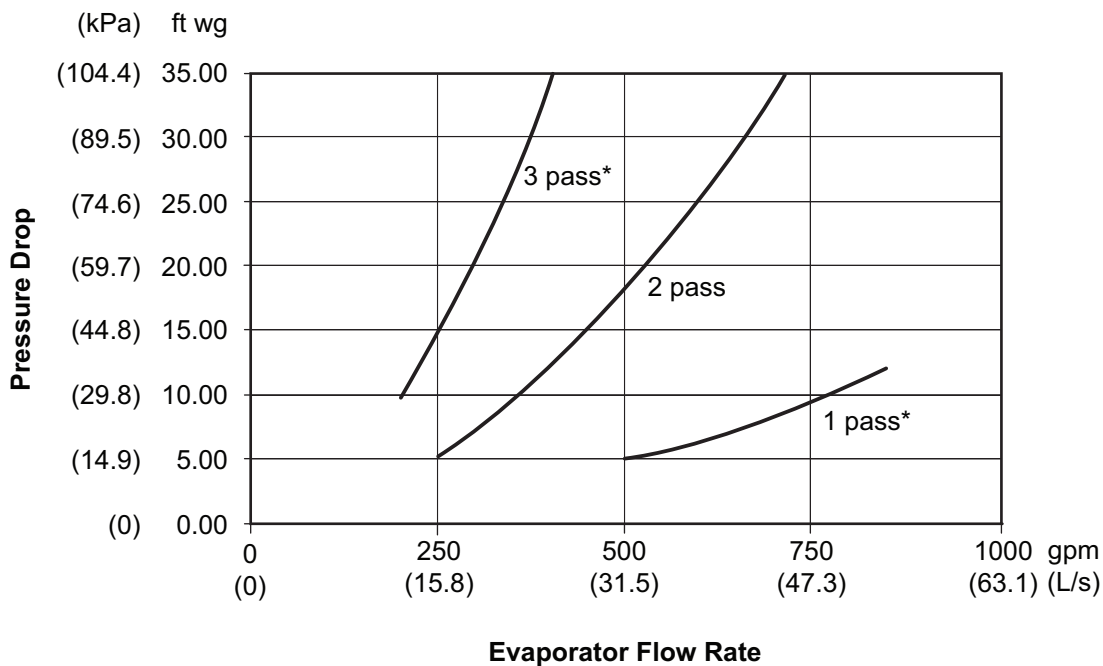

LEGEND

NIH — Nozzle-In-Head

* Applies to NIH flange only.

NOTE: The table above represents pressure drops only. The table does not imply that the chiller can be properly applied over the entire range of evaporator water flow rates represented. Pressure drop values are applicable to fresh water.

Performance data (cont)



30XW150-200 EVAPORATOR NIH VICTAULIC

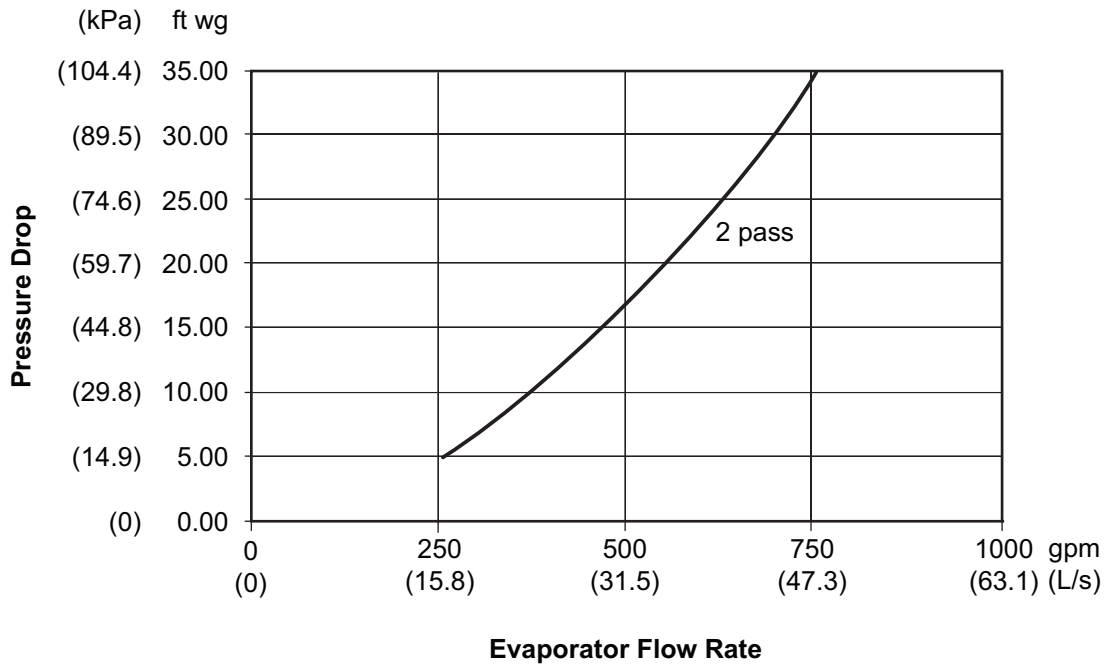

LEGEND

NIH — Nozzle-In-Head

NOTE: The table above represents pressure drops only. The table does not imply that the chiller can be properly applied over the entire range of evaporator water flow rates represented. Pressure drop values are applicable to fresh water.

30XW225-300 EVAPORATOR NIH VICTAULIC

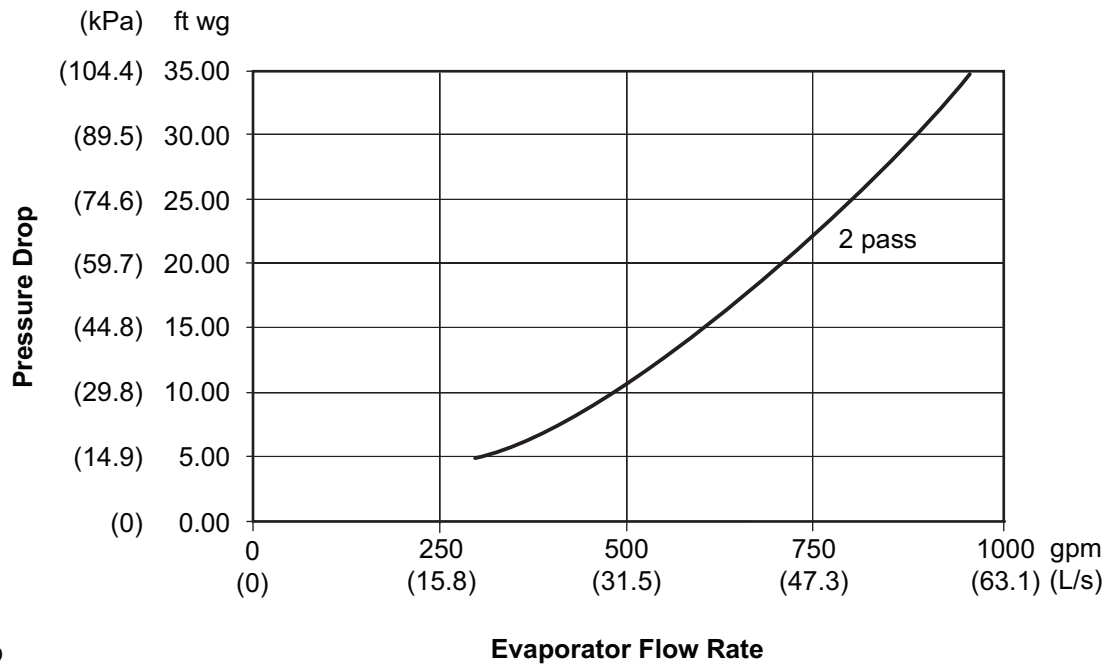

LEGEND

NIH — Nozzle-In-Head

NOTE: The table above represents pressure drops only. The table does not imply that the chiller can be properly applied over the entire range of evaporator water flow rates represented. Pressure drop values are applicable to fresh water.

30XW225-300 EVAPORATOR NIH FLANGE

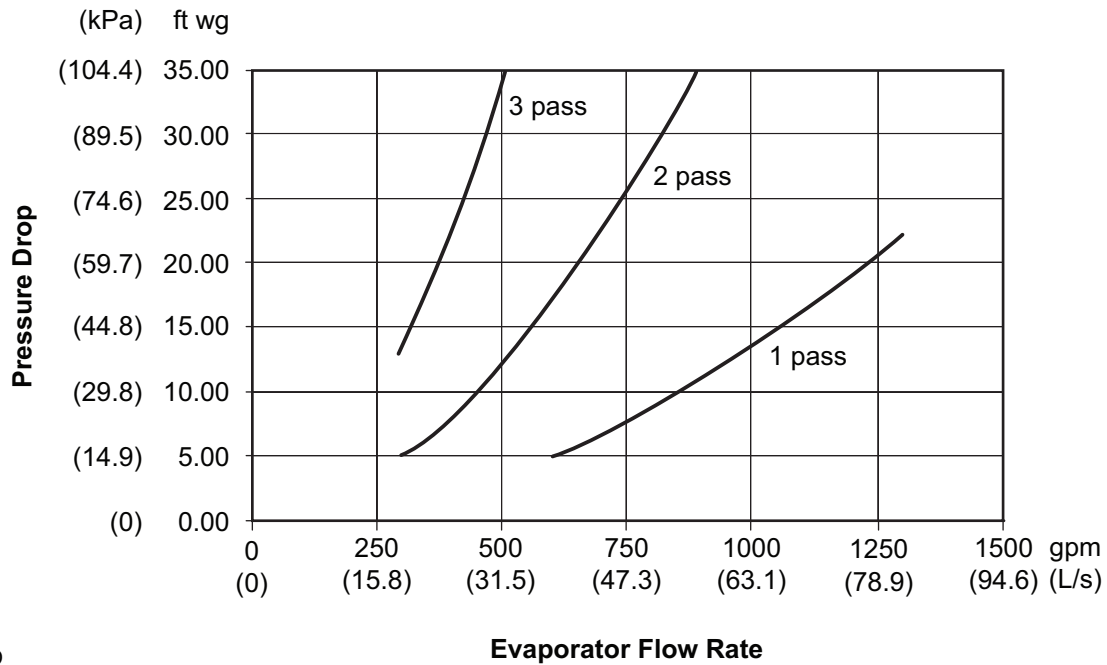

LEGEND

NIH — Nozzle-In-Head

NOTE: The table above represents pressure drops only. The table does not imply that the chiller can be properly applied over the entire range of evaporator water flow rates represented. Pressure drop values are applicable to fresh water.

30XW325-400 EVAPORATOR NIH FLANGE

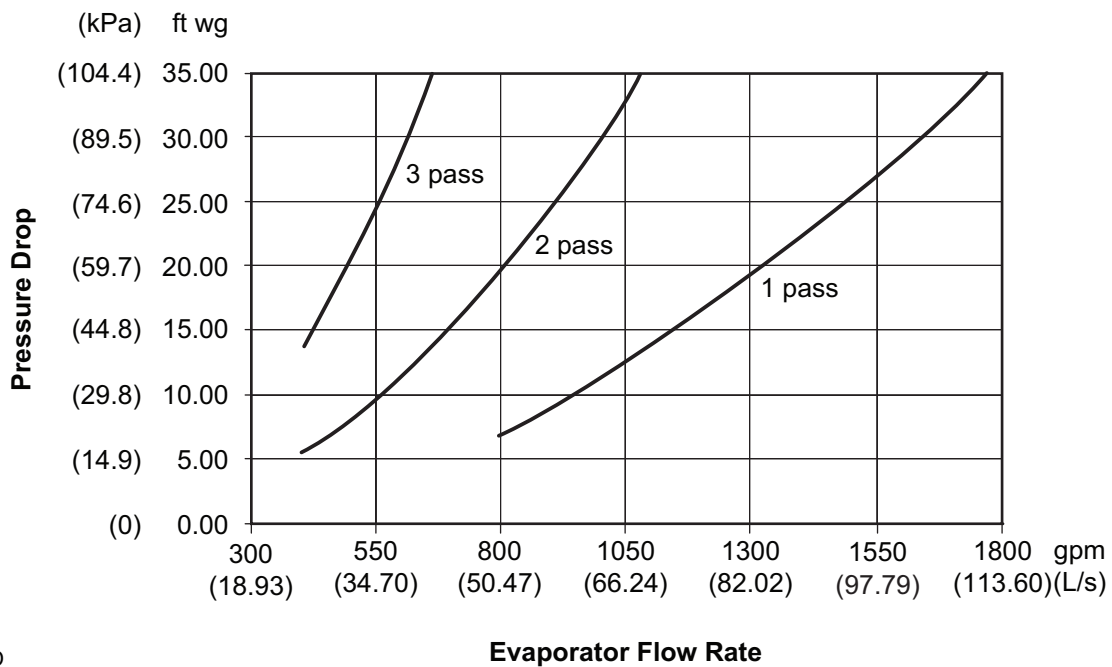

LEGEND

NIH — Nozzle-In-Head

NOTE: The table above represents pressure drops only. The table does not imply that the chiller can be properly applied over the entire range of evaporator water flow rates represented. Pressure drop values are applicable to fresh water.

Performance data (cont)



30XW325-400 EVAPORATOR NIH VICTAULIC

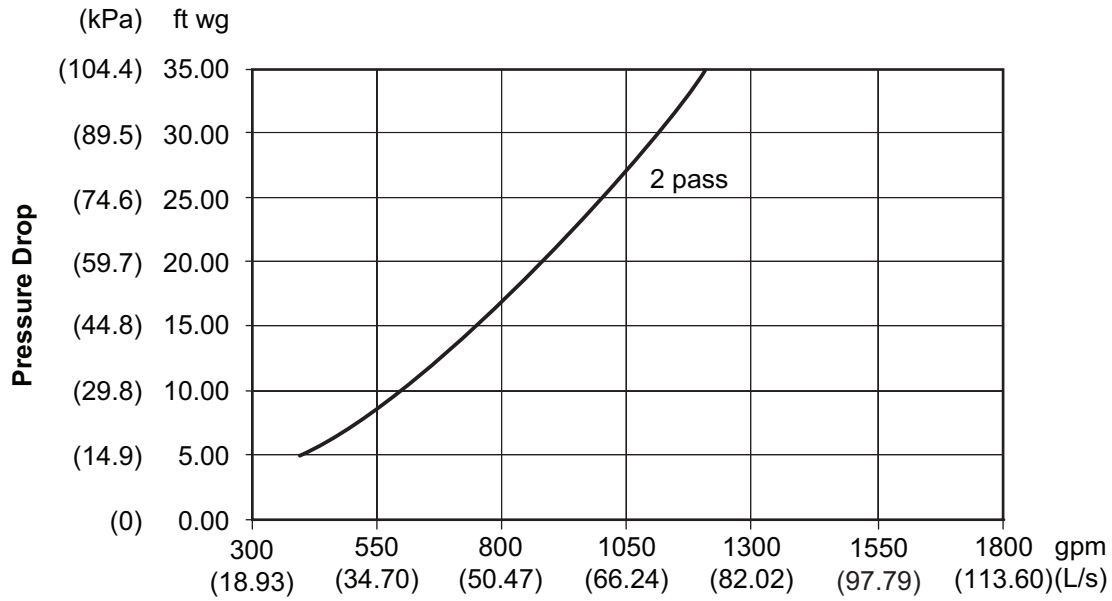

LEGEND

NIH — Nozzle-In-Head

Evaporator Flow Rate

NOTE: The table above represents pressure drops only. The table does not imply that the chiller can be properly applied over the entire range of evaporator water flow rates represented. Pressure drop values are applicable to fresh water.

30XW150-200 CONDENSER MARINE WATERBOX

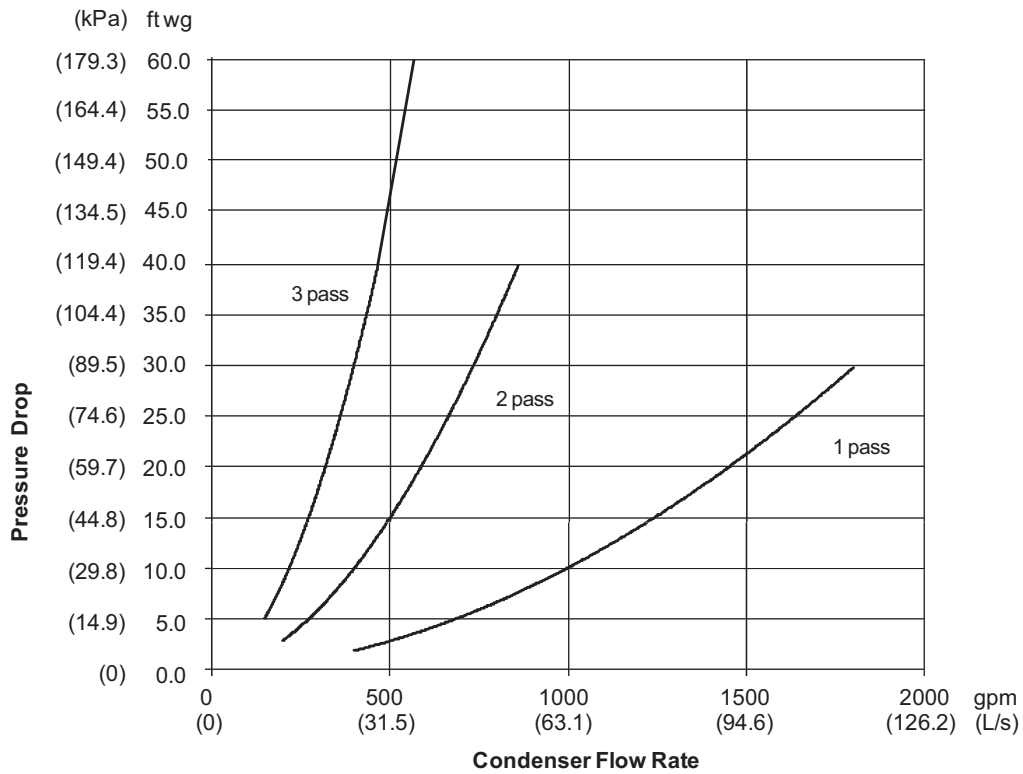

NOTE: The table above represents pressure drops only. The table does not imply that the chiller can be properly applied over the entire range of condenser water flow rates represented. Pressure drop values are applicable to fresh water.

30XW225-300 CONDENSER MARINE WATERBOX

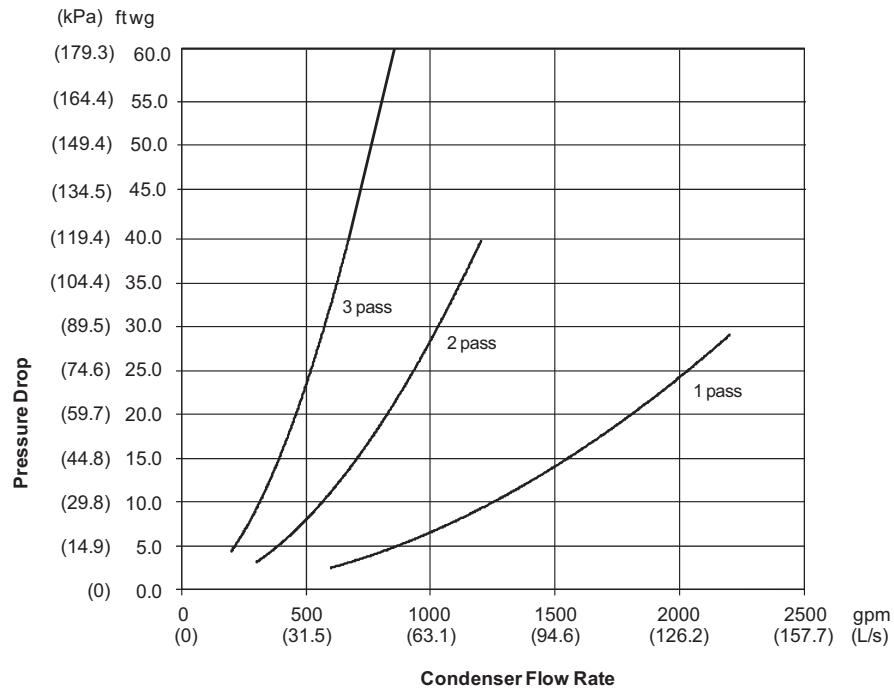

NOTE: The table above represents pressure drops only. The table does not imply that the chiller can be properly applied over the entire range of condenser water flow rates represented. Pressure drop values are applicable to fresh water.

30XW325-400 CONDENSER MARINE WATERBOX

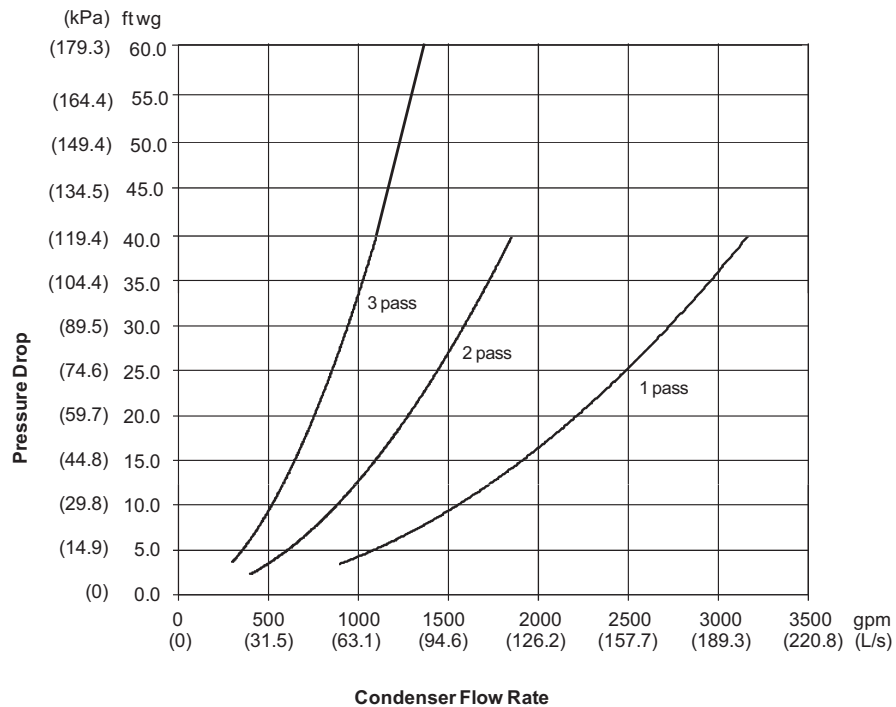

NOTE: The table above represents pressure drops only. The table does not imply that the chiller can be properly applied over the entire range of condenser water flow rates represented. Pressure drop values are applicable to fresh water.

Performance data (cont)



30XW150-200 CONDENSER NIH FLANGE

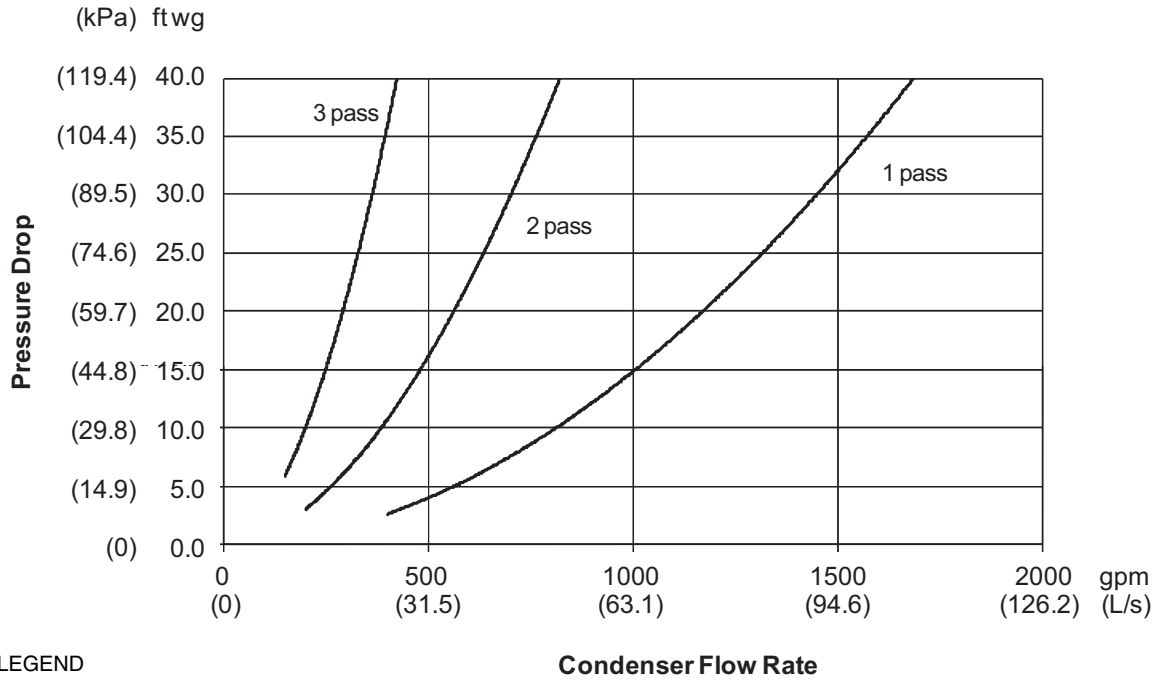

LEGEND

NIH — Nozzle-In-Head

NOTE: The table above represents pressure drops only. The table does not imply that the chiller can be properly applied over the entire range of evaporator water flow rates represented. Pressure drop values are applicable to fresh water.

30XW225-300 CONDENSER NIH FLANGE

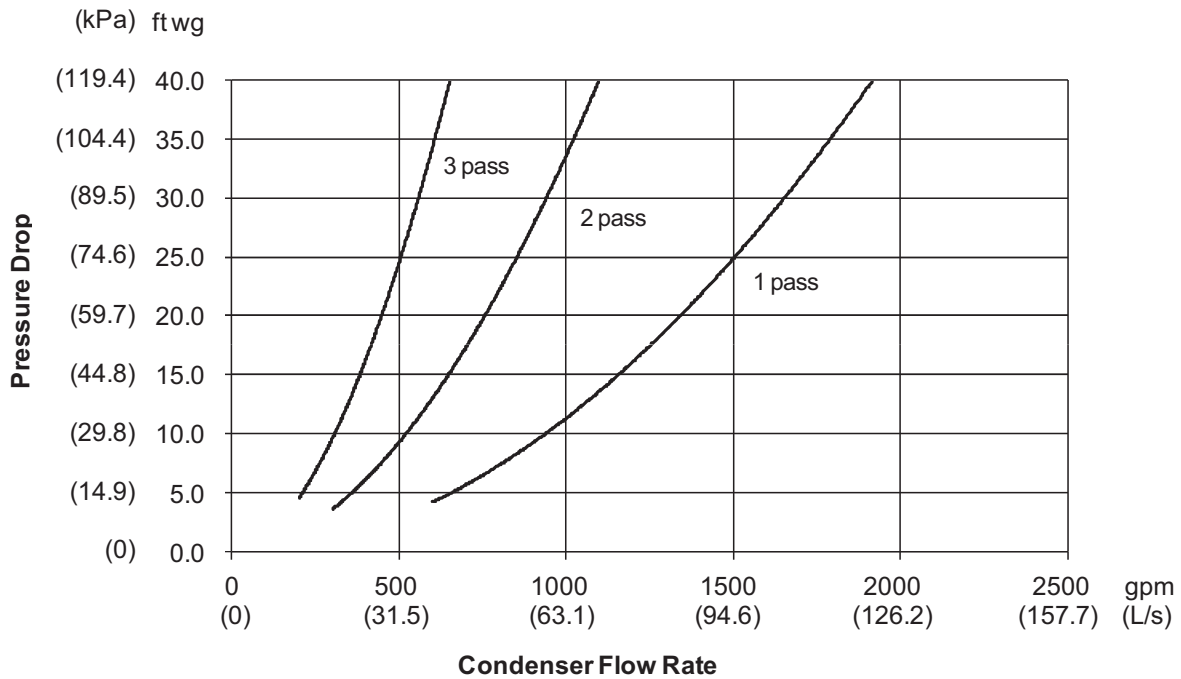

LEGEND

NIH — Nozzle-In-Head

NOTE: The table above represents pressure drops only. The table does not imply that the chiller can be properly applied over the entire range of evaporator water flow rates represented. Pressure drop values are applicable to fresh water.

30XW325-400 CONDENSER NIH FLANGE

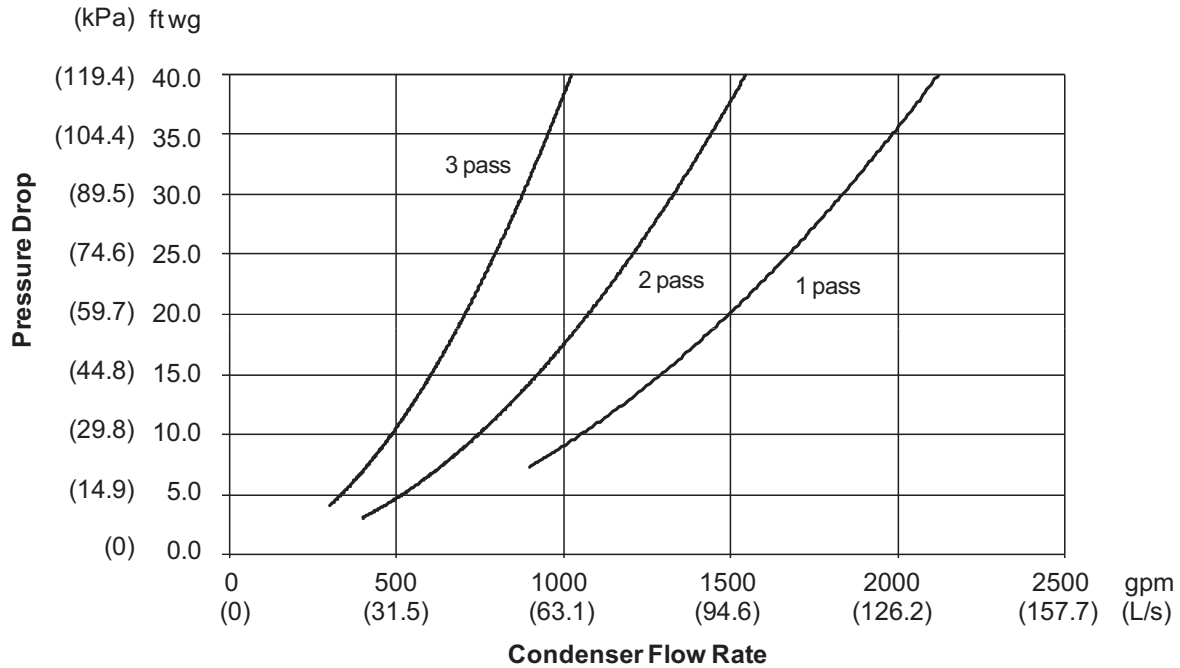

LEGEND

NIH — Nozzle-In-Head

NOTE: The table above represents pressure drops only. The table does not imply that the chiller can be properly applied over the entire range of evaporator water flow rates represented. Pressure drop values are applicable to fresh water.

30XW150-200 CONDENSER NIH VICTAULIC

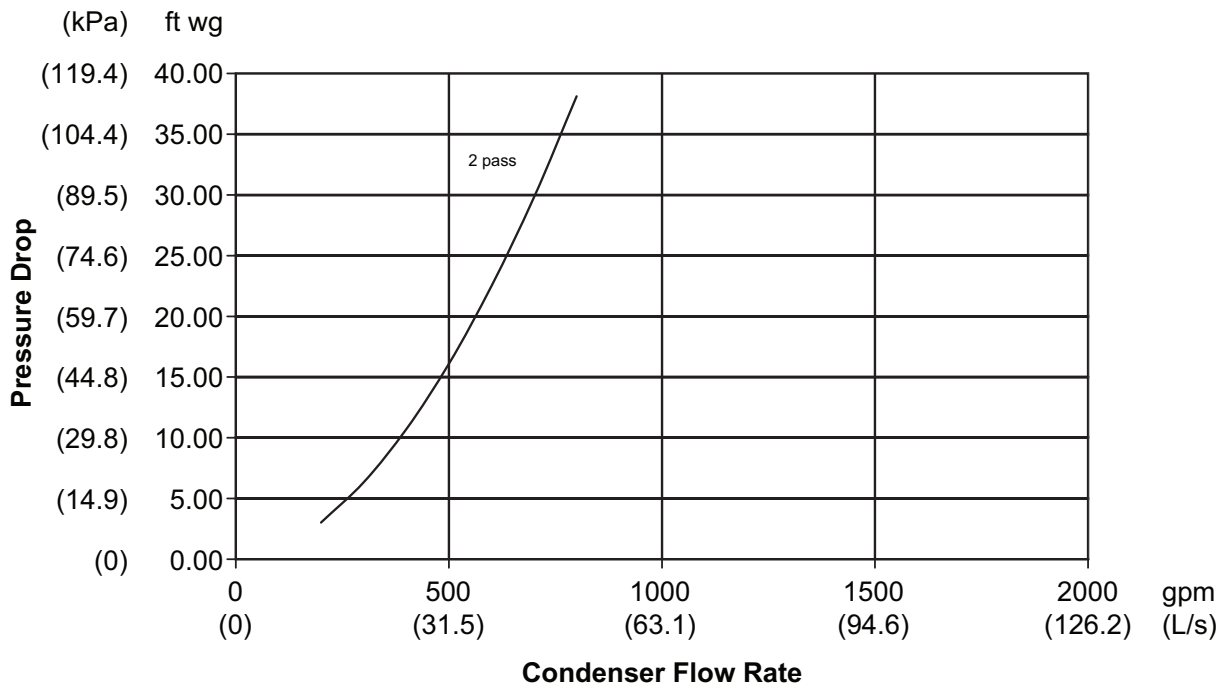

LEGEND

NIH — Nozzle-In-Head

NOTE: The table above represents pressure drops only. The table does not imply that the chiller can be properly applied over the entire range of evaporator water flow rates represented. Pressure drop values are applicable to fresh water.

Performance data (cont)



30XW225-300 CONDENSER NIH VICTAULIC

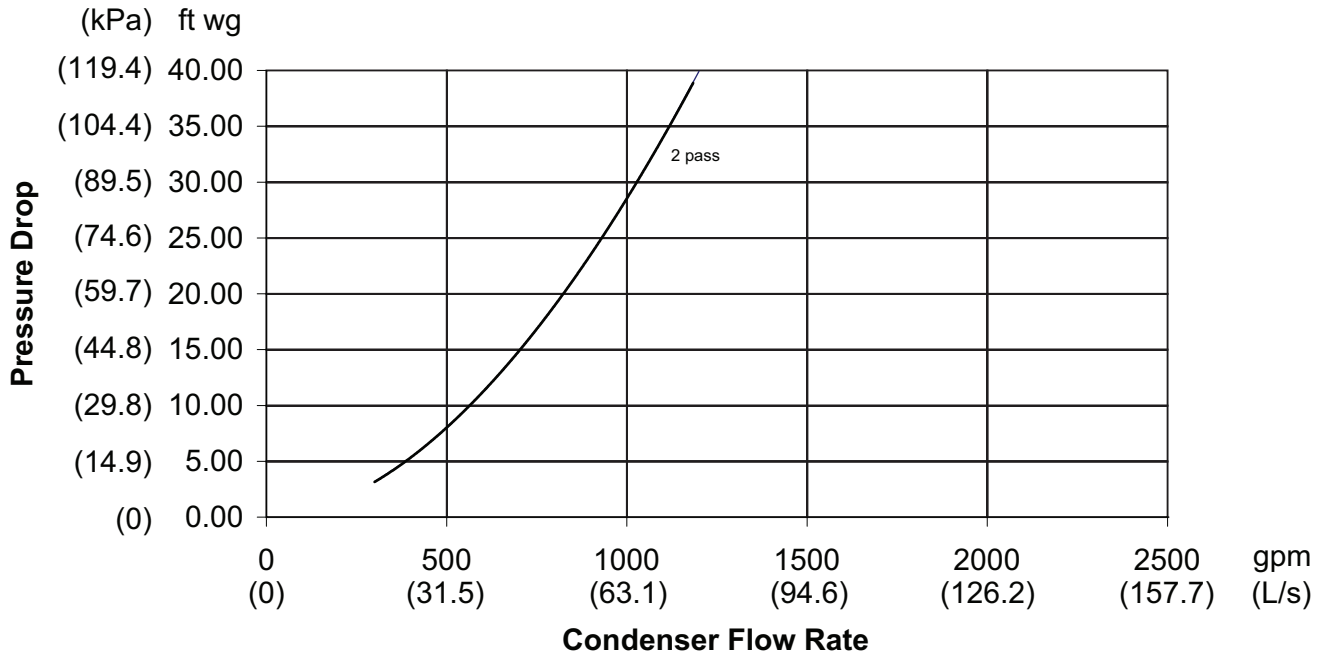

LEGEND

NIH — Nozzle-In-Head

NOTE: The table above represents pressure drops only. The table does not imply that the chiller can be properly applied over the entire range of evaporator water flow rates represented. Pressure drop values are applicable to fresh water.

30XW325-400 CONDENSER NIH VICTAULIC

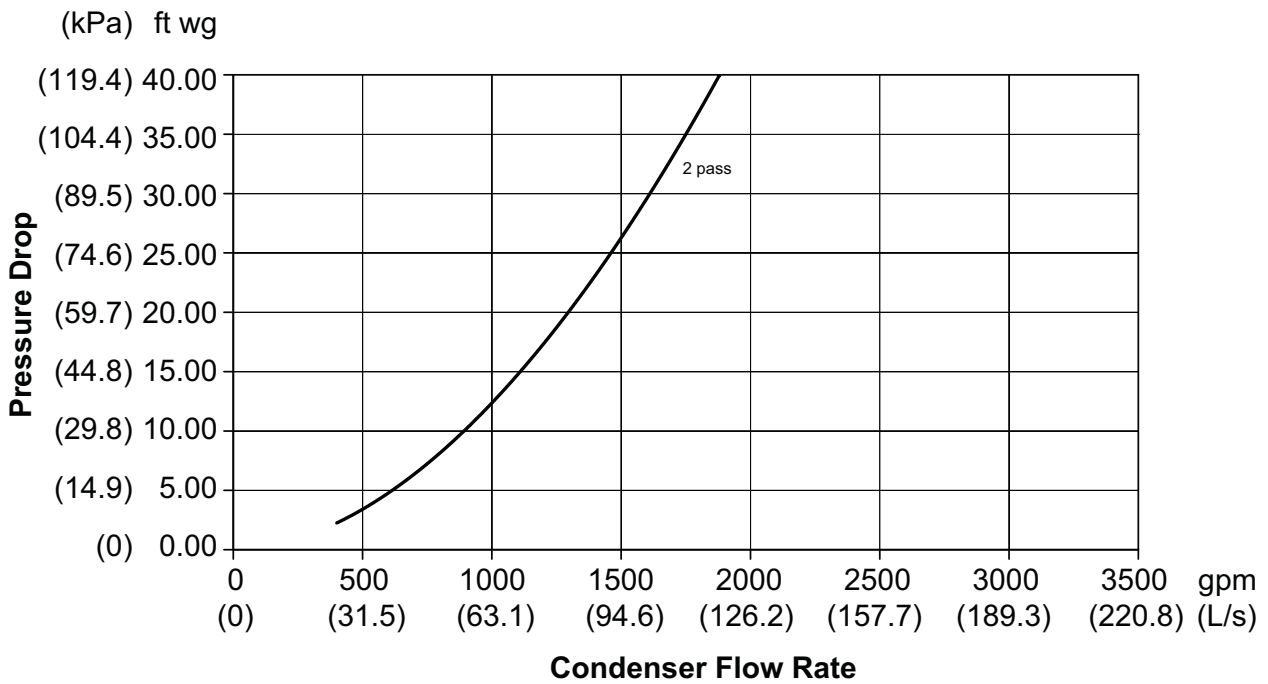

LEGEND

NIH — Nozzle-In-Head

NOTE: The table above represents pressure drops only. The table does not imply that the chiller can be properly applied over the entire range of evaporator water flow rates represented. Pressure drop values are applicable to fresh water.

Microprocessor

The chiller microprocessor controls overall unit operation and controls a number of processes simultaneously. These processes include internal timers, reading inputs, analog to digital conversions, display control, diagnostic control, output relay control, demand limit, capacity control, head pressure control, and temperature reset. Some processes are updated almost continuously, others every 2 to 3 seconds, and some every 30 seconds. The microprocessor routine is started by switching the emergency ON-OFF switch to the ON position.

Control sequence

Pre-start

After control switches on, the prestart takes place. The microprocessor checks itself, and if configured, energizes the evaporator and condenser pumps to the internal (or CCN) time schedule (or input occupied signal from an external system) and waits for temperature to stabilize.

Start-up

The chiller will receive a call for cooling when chilled fluid temperature increases above the set point plus a dead band, or if an override start command is received. If flow has been proven, the first compressor starts 1 to 3 minutes after the call for cooling. The controlled pulldown feature limits compressor loading on start up to reduce demand on start up and unnecessary compressor usage.

Capacity control

On the first call for cooling, the microprocessor starts the compressor on the lead circuit. The microprocessor maintains leaving fluid temperature set point through intelligent positioning of the slide valve. As the load increases above the compressor's capacity, the compressor on the lag circuit is started and both compressors are staged together.

Maintaining set point

The control monitors entering and leaving chilled water temperature to anticipate changes in cooling load. The speed at which capacity is added or reduced is controlled by temperature deviation from set point and rate of temperature change of the chilled fluid. The basic logic for determining when to add or remove capacity is a time band integration of deviation from set point plus rate of change of leaving fluid temperature. When leaving-fluid temperature is close to the set point and slowly moving closer, logic prevents additional capacity. Accuracy depends on loop volume, loop flow rate, load and condenser water temperatures.

Return fluid temperature compensation

No adjustment for cooling range or evaporator flow rate is required because the control automatically compensates for cooling range by measuring both return fluid temperature and leaving fluid temperature.

Low temperature override

This feature prevents LWT (leaving water temperature) from overshooting the set point to prevent nuisance low suction temperature trips.

High temperature override

This feature allows the chiller to add capacity quickly during rapid load variations.

Temperature reset (chilled water reset)

When latent loads in the conditioned space are reduced, it may be possible to reset the leaving chilled water temperature set point to a warmer temperature thereby reducing compressor power usage and saving energy. Three reset options are offered. With any chilled water reset application, humidity control should be considered since higher coil temperatures will reduce latent capacity. For details on applying a reset option, refer to the Controls, Start-Up, Operation, Service and Troubleshooting guide.

Return fluid temperature reset

This feature increases LWT set point as return (entering) fluid temperature decreases (indicating load decrease). This option may be used where return fluid temperature provides accurate load indication. No additional hardware is required.

Outdoor-air temperature reset

This feature increases LWT set point as outdoor ambient temperatures decreases (indicating load decrease). This reset should only be applied where outdoor ambient temperature is an indication of load. A field-installed thermistor is required.

Space temperature reset

This feature increases the LWT as space temperature decreases (indicating load decrease). This reset should only be applied where space temperature is an indication of load. A field-supplied thermistor is required.

Minimum load control

The main base board (MBB) responds to the supply chilled water temperature to match cooling load requirements and controls the minimum load control valve. The minimum load control valve allows hot gas to pass directly into the evaporator circuit permitting the unit to operate at lower loads with less compressor cycling. Minimum load control should be given consideration when operation is anticipated below the minimum unloading step.

Pull down control

If pulldown control has been selected (adjustable setting), no additional capacity is added as long as the difference between fluid temperature and the set point is greater than 4°F (2.2°C) and rate of change in leaving water temperature is greater than the 90 seconds since the last capacity change, compressors will continue to run unless a safety device trips. This prevents rapid cycling and also helps return oil during short operating periods.

Maximum operating pressure control

If the entering fluid temperature is 95°F (35°C) and the saturated suction temperature is 50°F (10°C) or higher, the maximum operating pressure (MOP) feature limits the suction to keep the chiller online. The control automatically starts the chiller in the unloaded state to eliminate the potential of compressor overload due to high head pressure or low suction pressure.

Equalized run time

The controller will equalize run time on each circuit through the lead/lag feature (sizes 325-400 only). If a circuit becomes disabled, the control will automatically set the active circuit to lead, keeping the chiller online at a reduced capacity.

Sensors

Thermistors are used to control temperature sensing inputs to the microprocessor. No additional sensors are required for leaving chilled water temperature or return water reset.

The following sensors can be used on 30XW units:

- Evaporator leaving fluid temperature (T1)
- Evaporator entering fluid temperature (T2)
- Suction gas temperature (T4-Circuit A, T7-Circuit B)
- Economizer gas temperature (T5-Circuit A, T11-Circuit B)
- Space temperature (T8)
- Discharge gas temperature (T9-Circuit A, T10-Circuit B)
- Condenser entering fluid temperature (T12)
- Condenser leaving fluid temperature (T13)
- Compressor motor temperature

Pressure

There are 3 (sizes 150, 185, 225, 260, 325, 375) or 4 (sizes 175, 200, 250, 275, 300, 350, 400) refrigerant pressure transducers used in each circuit for sensing suction, discharge, oil, and economizer (sizes 175, 200, 250, 275, 300, 350, 400) pressure. The microprocessor uses these inputs to control capacity. Evaporator suction and saturated condensing temperature are calculated from evaporator and condenser pressure.

Electronic expansion valve (EXV)

The EXV controls refrigerant flow to the evaporator for different operating conditions by varying an orifice size to increase or decrease the flow area through the valve based on microprocessor input. The orifice is positioned by a stepper motor through approximately 3,600 discrete steps and is monitored every 3 seconds.

Safeties

Abnormal conditions

All control safeties in the chiller operate through compressor protection board, control relays or the chiller microprocessor. Loss of feedback signal to the MBB (main base board) will cause the compressor(s) to shut down. For other safeties, the microprocessor makes appropriate decision to shut down a compressor due to a safety trip or bad sensor reading and displays the appropriate failure code on the display. Chiller holds in safety mode until reset; it then reverts to normal control when the unit is reset.

Low-pressure safety

This safety will shut down the chiller and display the appropriate alarm code if the system pressure drops below configured minimums.

High-pressure safety

This safety will shut down the chiller and display the appropriate alarm code if the compressor discharge pressure increases above configured maximums.

Compressor anti-cycling

This feature monitors compressor starts to limit compressor cycling during periods of low load.

Loss of flow protection

This feature will shut off the chiller if the detected flow is below the configured minimum flow rate. Thermal dispersion flow switches are installed in 30XW chillers to confirm evaporator flow.

Sensor failures

The microprocessor monitors temperature and pressure sensors to ensure readings are within the expected range. Loss of communication to a sensor or readings outside of the expected range will prompt corrective action.

Other safeties

Other safety features include electric overload, thermal overload protection, oil pressure, loss of refrigerant charge, loss of phase protection, reverse rotation protection (prevents compressor start), current imbalance, and ground current.

Demand limit function

This function can be used to limit the total power draw of the chiller to a user-defined set point. The optional energy management module is required and can provide either 2-step or 4 to 20 mA demand limit. This optional electronic board interfaces with the microprocessor to control the number of compressors operating and their operating capacity to limit power consumption to the user-specified value.

The microprocessor can control the number of compressors operating and their operating capacity to limit power consumption to the user-specified value.

Diagnostics

The microprocessor includes a service test feature that displays the condition of each sensor and switch in the chiller and allows the observer to check for proper operation of the compressors. Refer to the Controls, Start-Up, Operation, Service and Troubleshooting guide for further information.

Default settings

To facilitate quick start-ups, 30XW chillers are pre-configured with a default setting that assumes stand-alone operation with a 44°F (6.6°C) chilled water set point. Configuration settings will be based on any options or accessories included with the unit at the time of manufacturing. Date and time are set to U.S.A. Eastern Time zone and will need reconfiguring based on location and local time zone. If operation based on occupancy schedule is desired, the schedule must be set during installation.

Additional information

Detailed information on controls and operation is available in the Controls, Start-Up, Operation, Service and Troubleshooting guide included with each unit. Packaged Service Training programs are also available. Contact your local Carrier representative for more information.

Typical control wiring schematic

30XW UNIT CONTROL WIRING SCHEMATIC

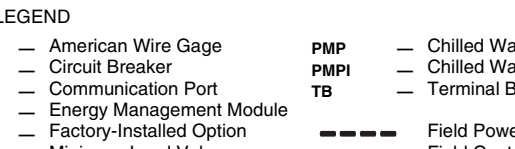
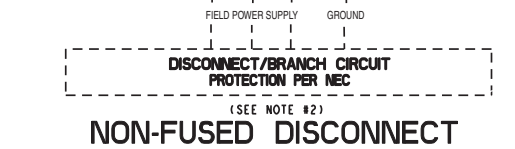
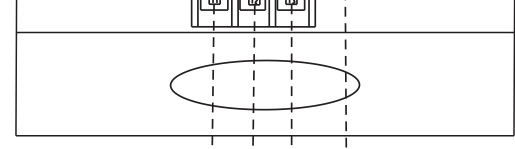
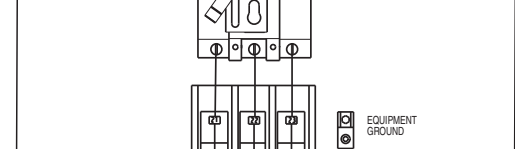
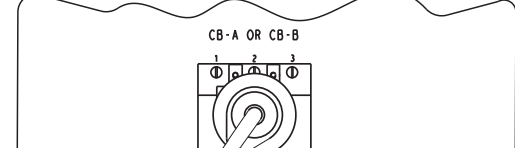
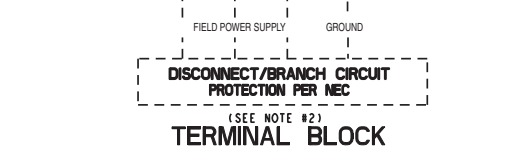
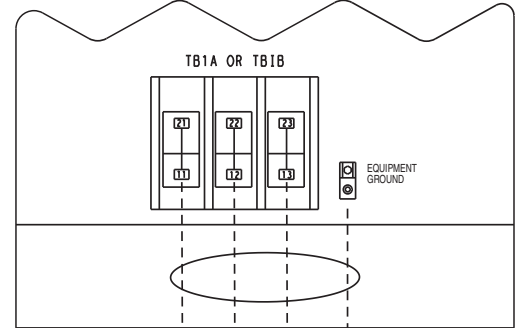
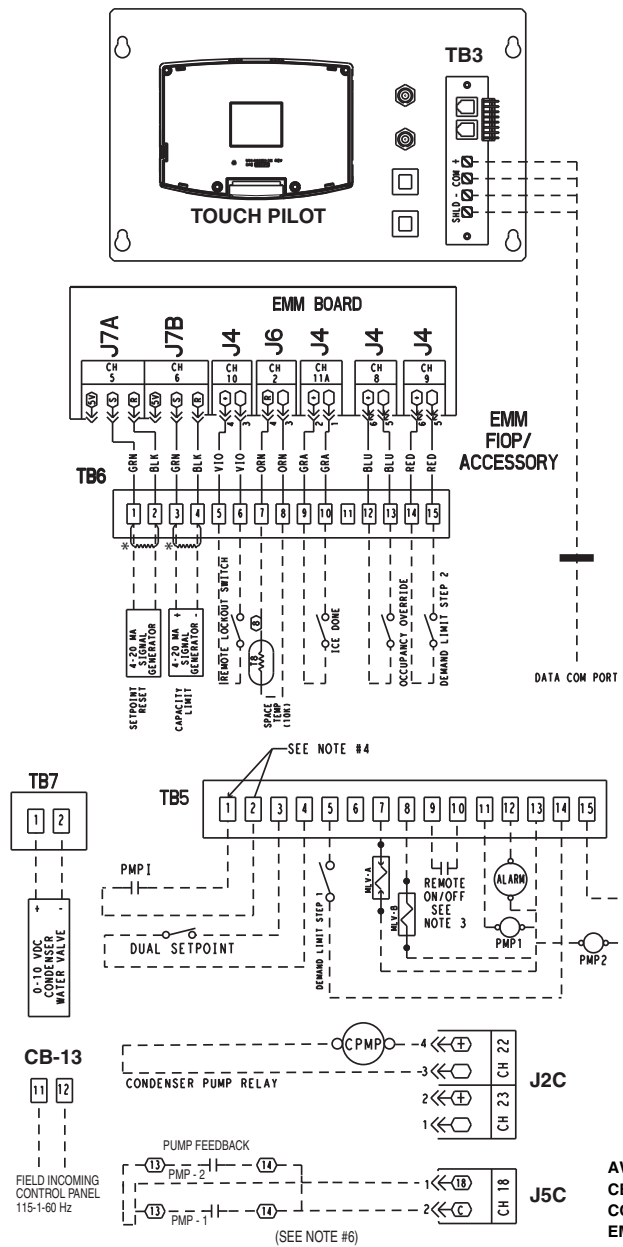

- LEGEND**
- | | | | |
|------|----------------------------|------|--------------------------------|
| AWG | — American Wire Gage | PMP | — Chilled Water Pump |
| CB | — Circuit Breaker | PMP1 | — Chilled Water Pump Interlock |
| COM | — Communication Port | TB | — Terminal Block |
| EMM | — Energy Management Module | ---- | Field Power Wiring |
| FIOP | — Factory-Installed Option | ---- | Field Control Wiring |
| MLV | — Minimum Load Valve | ---- | Factory-Installed Wiring |
| NEC | — National Electrical Code | | |

* Field supplied. 1/2 watt 250 ohm resistor required.

NOTES:

- Factory wiring is in accordance with UL 1995 standards. Field modifications or additions must be in compliance with all applicable codes.
- Wiring for main field supply must be rated 75C minimum. Use copper for all units. Incoming wire size range for the terminal block is #4 AWG to 500 kcmil for single point power (two conductors per phase). Incoming wire size range for the terminal blocks for dual point power option is #4 AWG to 500 kcmil for single point power (one conductor per phase). Incoming wire size range for 200 and 230-v models is 3/0 to 500 kcmil for single point power (one conductor per phase). Unit sizes 150-300 are available only with single point power connections.
- Terminals 9 and 10 of TB5 are for field external connections for remote on-off. The contacts must be rated for dry circuit application capable of handling a 24-vac load up to 50 mA.
- Terminals 1 and 2 of TB5 are for external connections of chilled water pump interlock. The contacts must be rated for dry circuit application capable of handling a 24-vac load up to 50 mA.
- Terminals 11 and 13 of TB5 are for control of chilled water pump 1 (PMP 1) starter. Terminals 15 and 13 of TB5 are for control of chilled water pump 2 (PMP 2) starter. Remove factory-installed jumper when using pump interlock. The maximum load allowed for the chilled water pump relay is 5-va sealed, 10-va inrush at 24-v. Field power supply is not required.
- For control of chilled water pumps, a set of normally open contacts rated for dry circuit application must be supplied from field-supplied pump starter relay. Connect contacts directly to connector at main base board J5C channel 18.
- Terminals 12 and 13 of TB5 are for an alarm relay. The maximum load allowed for the alarm relay is 10-va sealed, 25-va inrush at 24-v. Field power supply is not required.
- Make appropriate connections to TB6 as shown for energy management board options. The contacts for occupancy override, demand limit, and ice done options must be rated for dry circuit application capable for handling a 24-vac load up to 50 mA.
- Terminal blocks TB5 and TB6 are located in the display panel box for all units. Refer to certified dimensional drawing for each unit to get the exact locations.
- Refer to certified dimensional drawings for exact locations of the main power and control power entrance locations.
- For control of condenser pump, connect field-supplied relay (max 5-va sealed, 10-va inrush at 24-v) directly to terminals 3 and 4 (channel 22) of J2C on the main base board.
- Terminals 1 and 2 of TB7 provide 0 to 10-vdc signal for head pressure control. Refer to controls manual for configuration of field-supplied water regulating valve control parameters.

Unit storage

Store chiller and starter indoors, protected from construction dirt and moisture. Inspect under shipping tarps, bags, or crates to be sure water has not collected during transit. Keep protective shipping covers in place until machine is ready for installation. Assure that the inside of the protective cover meets the following criteria:

- Temperature is between 40°F (4.4°C) and 120°F (48.9°C)
- Relative humidity is between 10% and 80% (non-condensing)

Chiller location

Unit should be located indoors on a level surface in an area with temperatures between 50°F (10°C) and 104°F (40°C). Clearance should be provided around the unit for service and local code requirements. See dimensional drawings for specific unit clearance requirements. Consideration should be given to using rubber-in-shear pads. For applications other than ground to slab, it is recommended spring isolators are used to minimize structure borne transmission. Acoustic consideration should be given near sound sensitive areas.

Relief valve vent lines:

1. Vent per local code requirements.
2. Each chiller has one relief valve per circuit on the evaporator, 2 per circuit on the condenser, and one relief valve on each compressor discharge line.

Strainers

A screen strainer with minimum screen size of 20 mesh must be installed within 10 ft (3 m) of the inlet pipe connection to both the evaporator and condenser to prevent debris from damaging internal tubes of the evaporator. The pump strainer shall not be used to meet this requirement.

Oversizing chillers

Oversizing chillers by more than 15% at design conditions should be avoided as the system operating efficiency is adversely affected (resulting in greater or excessive electrical demand). When future expansion of equipment is anticipated, install a single chiller to meet present load requirements and add a second chiller to meet the additional load demand. It is also recommended that 2 smaller chillers be installed where operation at minimum load is critical. The operation of a smaller chiller loaded to a greater percentage over minimum is preferred to operating a larger chiller at or near its minimum recommended value. Operation at its minimum load should only be done intermittently, not for long periods of time. Minimum load control should not be used as a means to allow oversizing chillers.

Evaporator water temperature

Maximum leaving fluid temperature for the unit is 56°F (13.3°C). The unit can start and pull down with up to 95°F (35°C) entering fluid temperature. For sustained operation, it is recommended the fluid temperature not exceed 70°F (21.1°C). Water flowing through the evaporator should never exceed 100°F (37.8°C). Minimum leaving water temperature is 40°F (4.4°C).

Brine applications

When leaving chilled fluid temperatures are lower than 40°F (4.4°C), an appropriate antifreeze solution must be used in the evaporator. The 30XW chillers selected with the brine option are equipped with factory-installed evaporator and condenser water flow switches. In order to protect the chiller, the chiller must control the evaporator and condenser pumps. Evaporator and condenser flow may be required even after the chiller has shut down. In the event of a loss of condenser water flow, the flow of chilled fluid to the evaporator must be stopped or the isolation valve must be closed. This is necessary to reduce the possibility of condenser freeze-up. When applying head pressure control to brine units, the minimum condenser flow rate must be greater than the minimum condenser flow switch setting. This may require a re-circulating loop to ensure that both minimum condenser flow rate and adequate head pressure control are met simultaneously.

Evaporator flow range

For minimum and maximum evaporator flow rates please see the Evaporator and Condenser Flow Rates table on page 31. A high flow rate is generally limited by the maximum pressure drop that can be tolerated by the unit. The 30XW chillers are designed for a full load temperature rise of 5 to 20°F (2.8 to 11.1°C). See the Carrier selection program for pressure drop values and performance.

Minimum evaporator flow

When system design conditions require a lower flow (or higher temperature rise) than the minimum allowable evaporator flow rate, please follow the recommendations below.

- Multiple smaller chillers may be applied in series, each providing a portion of the design temperature rise.
- Try increasing the number of passes in the evaporator at design conditions (1, 2, or 3 passes available).
- Evaporator fluid may be recirculated to raise the flow rate to the chiller. The mixed temperature entering the evaporator must be maintained to a minimum of at least 5°F (2.8°C) above the leaving chilled fluid temperature and a maximum of no more than 20°F (11.1°C) above the leaving chilled fluid temperature.

NOTE: Recirculation flow is shown on the following page.

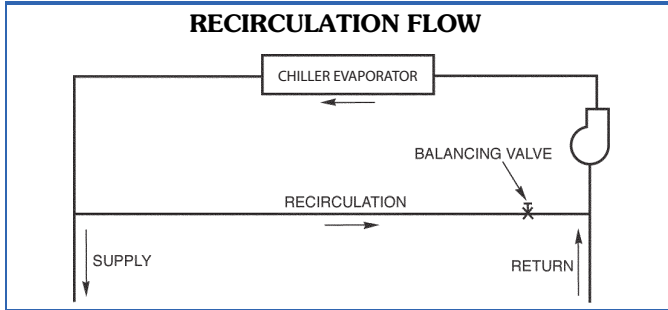

Maximum evaporator flow

The maximum evaporator flow (approximately 5°F (2.8°C) rise) results in a practical maximum pressure drop through the evaporator. Optional marine waterboxes may help reduce pressure drop by a small amount. If this is insufficient, a return fluid may bypass the evaporator to keep the pressure drop through the evaporator within acceptable limits. This permits a higher delta T with lower fluid flow through the evaporator and mixing after the evaporator.

NOTE: Bypass flow is shown below.

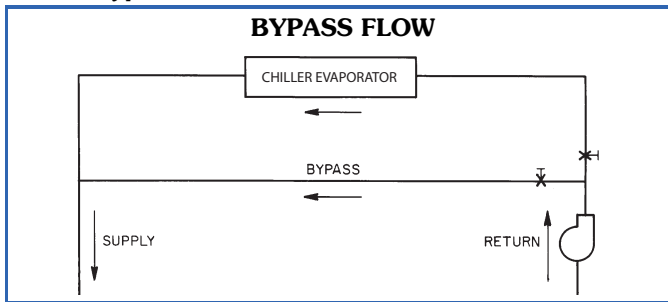

Variable evaporator flow rates

Variable flow rates may be applied to a standard chiller. The unit will, however, attempt to maintain a constant leaving fluid temperature. In such cases minimum flow at design conditions must be in excess of minimum flow given in the Evaporator and Condenser Flow Rates table, and minimum loop volume must be as defined below. Combined flow rate and change in load must not change by more than 10% per minute. Additional loop volume may be necessary to ensure fluid is not quickly recirculated back to the chiller before the chiller has adjusted to the previous change in flow rate and load condition. At part loads, evaporator flow rates as low as 67% of the minimum flow listed in the Evaporator and Condenser Flow Rates table on page 31 are acceptable.

Water loop volume

The loop volume in circulation must equal or exceed 3 gal. per nominal ton (3.2 L per kW) of cooling for temperature stability and accuracy in normal air-conditioning applications as well as heat machine applications. In process cooling applications, there should be 6 to 10 gallons per ton (6.5 to 10.8 L per kW). To achieve this loop volume, it is often necessary to install a tank in the loop. The tank should be baffled to ensure there is no stratification, and

that water (or brine) entering the tank is adequately mixed with liquid in the tank. See Tank Installation drawing.

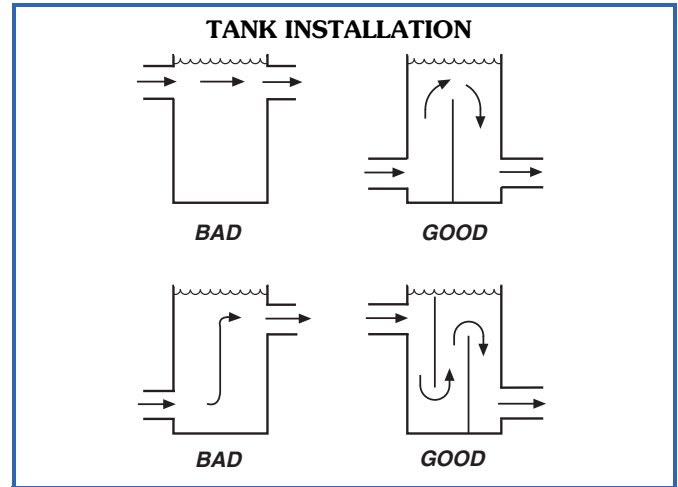

Evaporator fouling factor

The fouling factor used to calculate tabulated ratings is 0.0001 sq ft · hr °F/Btu (0.000018 sq m · °C/W). As fouling factor is increased, both unit capacity and EER (Energy Efficiency Ratio) decrease. The impact of the fouling factor on performance varies significantly with chiller size and application conditions. Ratings must be determined by the Carrier selection program.

Condenser minimum flow rate

The minimum condenser flow rate is shown in the Evaporator and Condenser Flow Rates table on page 31. If the condenser flow rate is below the minimum rate shown, try increasing the number of condenser passes (1, 2 or 3 pass available).

Evaporator and condenser freeze protection

The solution concentration must be sufficient to protect the chilled water loop to a freeze protection (first crystals) concentration of at least 15°F (8.3°C) below the leaving fluid temperature set point. If chiller fluid lines are in an area where ambient conditions fall below 34°F (1.1°C), it is recommended that an antifreeze solution be added to protect the unit and fluid piping to a temperature 15°F (8.3°C) below the lowest anticipated temperature. For corrections to performance, refer to the chiller selection program.

NOTE: Use only antifreeze solutions approved for heat exchanger duty. Use of automotive antifreeze is not recommended because of the fouling that can occur once their relatively short-lived inhibitors break down.

Multiple chillers

Where multiple chillers are required, or where standby capability is desired, chillers may be installed in parallel. Units may be of the same or different sizes. However, evaporator flow rates must be balanced according to the recommendations of each chiller to ensure proper flow.

Unit software is capable of controlling two units as a single plant. Refer to the Controls, Start-Up, Operation, Service and Troubleshooting guide for further details.

Dual chiller control

The chiller on board controller allows 2 chillers (piped in parallel or series) to operate as a single chilled water plant with standard control functions coordinated through the master chiller controller. This feature requires a communication link between the 2 chillers. There are several advantages to this type of control:

- Redundancy (multiple circuits)
- Better low load control (lower tonnage capability)
- Lower rigging lift weights (2 machines rather than one large machine)
- Chiller lead-lag operation (evens the wear between the two machines)

Condenser fluid temperature

Standard 30XW units will start at entering condenser fluid temperatures above 55°F (12.8°C). In general, however, continuous machine operation with entering condenser fluid temperatures below 65°F (18.3°C) is not recommended. When the entering condenser fluid temperature is expected to drop below 65°F (18.3°C), it is recommended that some form of condenser flow control be used to optimize performance. Tower pump, bypass valves, or flow regulating valves may be controlled by a 4 to 20 mA output from the 30XW controller (60-second open to close time recommended for actuator).

Parallel chiller operation

Parallel chiller operation is the recommended option for dual chiller control. In this case, each chiller must control its own dedicated pumps or isolation valves. Balancing valves are recommended to ensure the proper flow to each chiller. Two field-supplied and installed dual chiller leaving water temperature sensors are required (one for each module) for this function to operate properly.

Consider adding additional isolation valves to isolate each chiller to allow for service on the machine, and still allow for partial capacity from the other chiller.

Series chiller operation

Series chiller operation is an alternate control method supported by the chiller control system. Certain applications might require that two chillers be connected in series. For nominal 10°F (5.6°C) evaporator ranges, use the one-pass heat exchanger options to reduce fluid side pressure drop. Use the standard pass arrangement for low flow, high temperature rise applications. Two field-supplied and installed

dual chiller leaving water temperature sensors are required (one for each module) for this function to operate properly.

Consider adding additional piping and isolation valves to isolate each chiller to allow for service on the machine, and still allow for partial capacity from the other chiller.

Even if evaporators are piped in series, parallel condenser piping should be considered on constant speed chillers to maximize capacity and efficiency while minimizing condenser pressure drop and saturated condensing temperatures. If the condensers are piped in series, ensure that the leaving fluid temperature does not exceed 118°F (47.8°C) for standard units, or 140°F (60°C) for high condensing or heat machine condensers.

Electric utility interests

Energy management

Use of energy management practices can significantly reduce operating costs, especially during off-peak modes of operation. Demand limiting and temperature reset are two techniques for accomplishing efficient energy management. See Demand Limiting (also called load shedding) section below for further details.

Demand limiting (load shedding)

When a utility's demand for electricity exceeds a certain level, loads are shed to keep electricity demand below a prescribed maximum level. The energy management module (EMM) option can be added to accomplish this reduction. Demand may be limited on the unit by resetting water temperature, or by unloading the chiller to a given predetermined percentage of the load. Demand limit may also be driven by an external 4 to 20 mA signal. These features require a signal from an intelligent central control.

Duty cycling

Duty cycling will cycle an electrical load at regular intervals regardless of need. This reduces the electrical demand by “fooling” demand measuring devices. Duty cycling of the entire compressor is NOT recommended since motor windings and bearing life will suffer from constant cycling.

Remote on-off control

Remote on-off control may be applied by hard-wired connection (see the Controls, Start-Up, Operation, Service and Troubleshooting guide) or by connection to the Carrier Comfort Network® (CCN) system.

TYPICAL PIPING AND WIRING FOR 30XW150-300 EVAPORATOR AND CONDENSER

*Control power supply is not required for chillers ordered with the control power transformer option.

NOTES:

1. Wiring and piping shown are for general point-of-connection only and are not intended to show details for a specific installation. Certified field wiring and dimensional diagrams are available upon request. The 30XW units should be installed using certified drawings.
2. All wiring must comply with applicable codes.
3. Refer to Carrier System Design Manual for details regarding piping techniques.
4. Piping, wiring, switches, valves, vent gages, strainers, drain piping, drain, and vibration isolation are all field supplied.
5. Water connections are shown on left side (discharge end) of control box in this figure. Actual connections can be on either side according to chiller configuration ordered.
6. Operating environment — Chiller should be installed in an indoor environment where the ambient temperature is between 40 to 104°F (4 to 40°C) with a relative humidity (non-condensing) of 95% or less. To ensure that electrical components operate properly, do not locate the chiller in an area exposed to dust, dirt, corrosive fumes, or excessive heat and humidity.

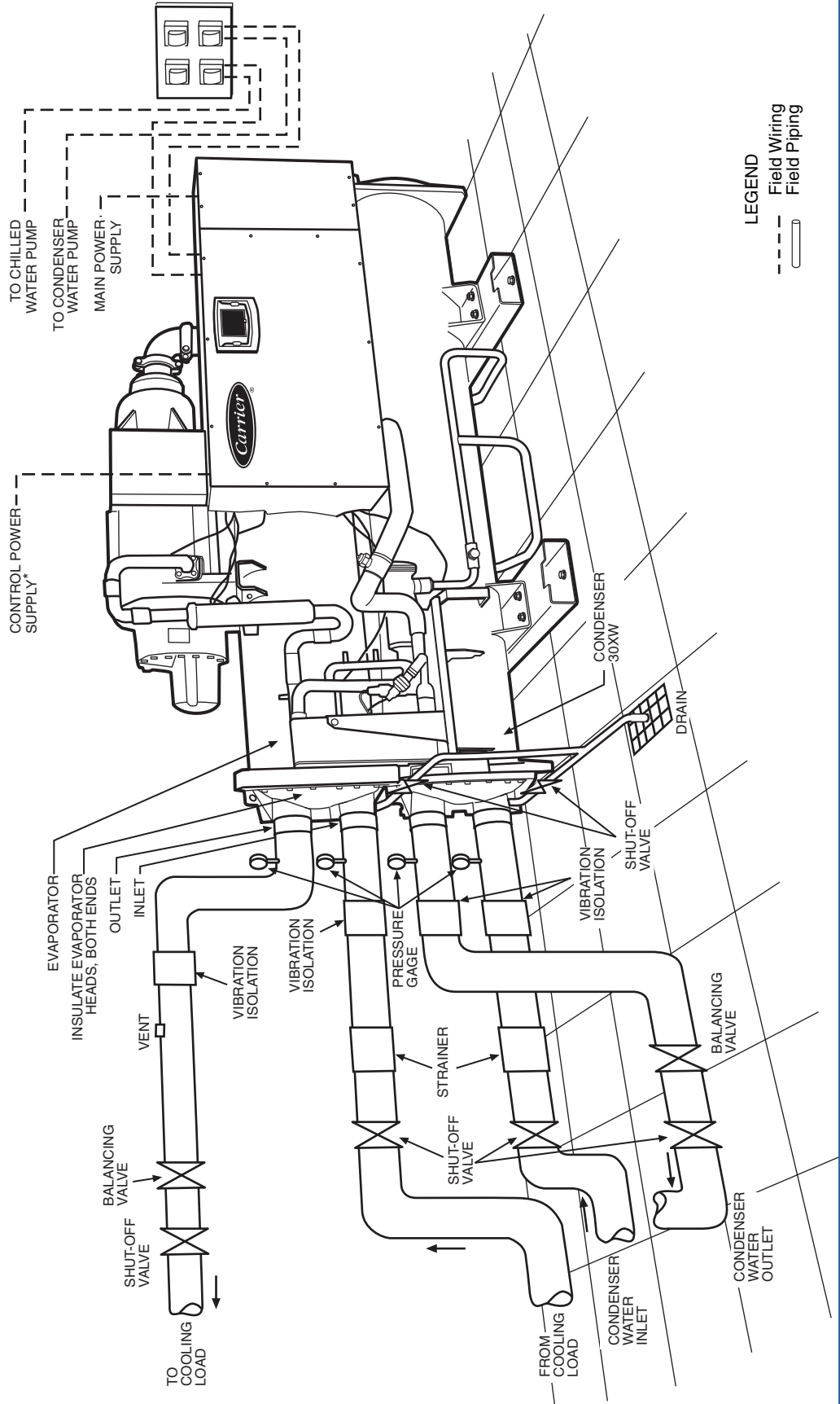

Typical piping and wiring (cont)

TYPICAL PIPING AND WIRING FOR 30XW325-400 EVAPORATOR AND CONDENSER

*Control power supply is not required for chillers ordered with the control power transformer option.

NOTES:

1. Wiring and piping shown are for general point-of-connection only and are not intended to show details for a specific installation. Certified field wiring and dimensional diagrams are available upon request. The 30XW units should be installed using certified drawings.
2. All wiring must comply with applicable codes.
3. Refer to Carrier System Design Manual for details regarding piping techniques.
4. Piping, wiring, switches, valves, vent gages, strainers, drain piping, drain, and vibration isolation are all field supplied.
5. Water connections are shown on left side (discharge end) of control box in this figure. Actual connections can be on either side according to chiller configuration ordered.
6. Operating environment — Chiller should be installed in an indoor environment where the ambient temperature is between 40 to 104°F (4 to 40°C) with a relative humidity (non-condensing) of 95% or less. To ensure that electrical components operate properly, do not locate the chiller in an area exposed to dust, dirt, corrosive fumes, or excessive heat and humidity.

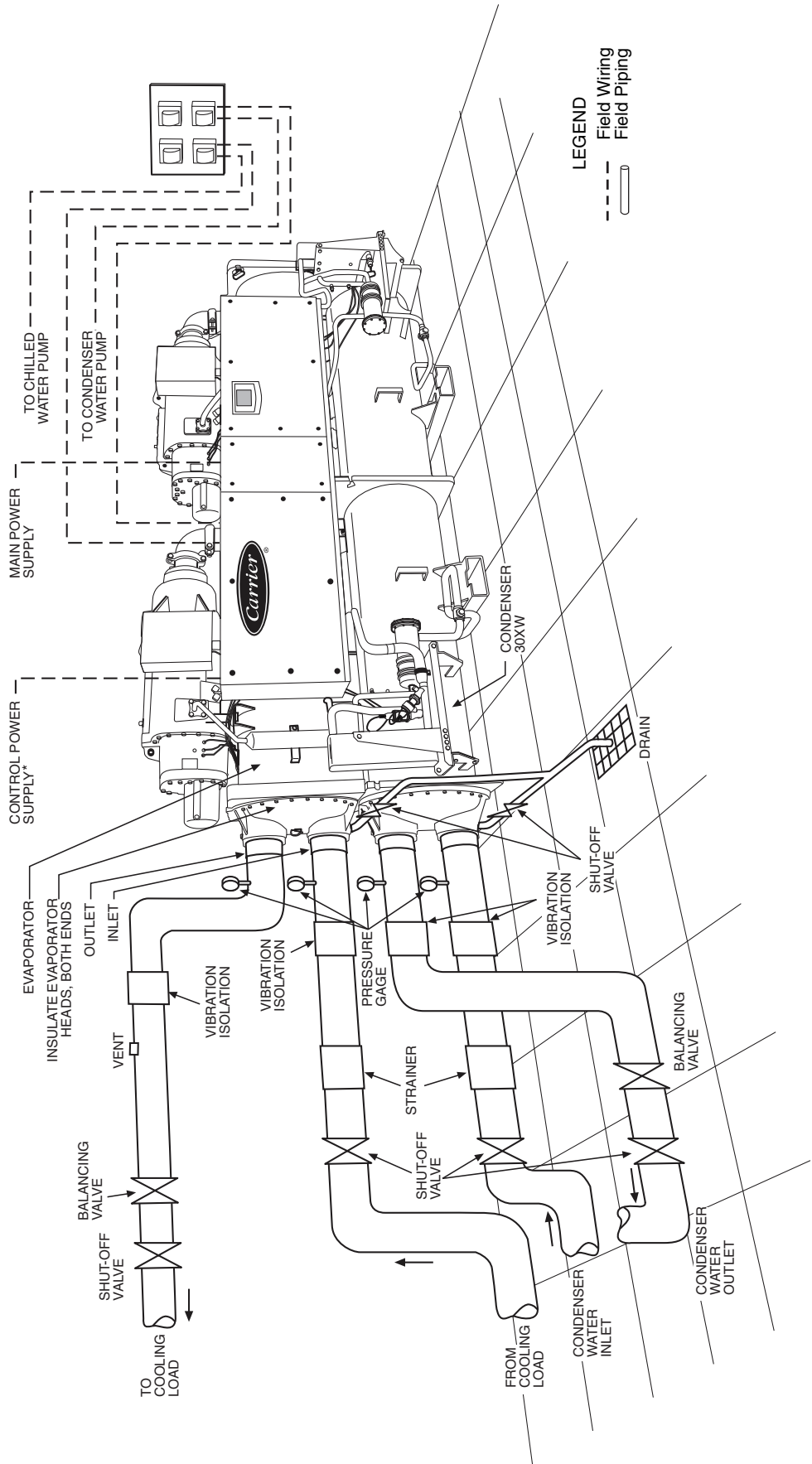

STANDARD SINGLE INPUT POWER CONFIGURATION

30XW UNIT SIZE	UNIT VOLTAGE			NO. POWER SUPPLY CONDUCTORS	MCA	MOCP	ICF		REC FUSE SIZE	CONTROL CIRCUIT	
	V-Ph-Hz	Supplied					WD	XL		VOLTAGE 1 PH, 60 Hz	MCA and MOCP
		Min	Max								
150	200-3-60	187	220	6	511.3	800	938.0	—	700	115	20
	230-3-60	207	253	6	443.9	700	816.0	—	600	115	20
	380-3-60	342	418	3	270.9	450	494.0	1537.0	350	115	20
	460-3-60	414	506	3	222.8	400	408.0	1270.0	300	115	20
	575-3-60	518	633	3	176.3	300	326.0	1016.0	225	115	20
150 HM	200-3-60	187	220	6	649.0	1000	1329.0	—	800	115	20
	230-3-60	207	253	6	565.8	1000	1156.0	—	700	115	20
	380-3-60	342	418	3	341.4	600	700.0	2179.0	450	115	20
	460-3-60	414	506	3	283.8	500	578.0	1800.0	350	115	20
	575-3-60	518	633	3	226.0	400	462.0	1440.0	300	115	20
175	200-3-60	187	220	6	511.3	800	938.0	—	700	115	20
	230-3-60	207	253	6	443.9	700	816.0	—	600	115	20
	380-3-60	342	418	3	270.9	450	494.0	1537.0	350	115	20
	460-3-60	414	506	3	222.8	400	408.0	1270.0	300	115	20
	575-3-60	518	633	3	176.3	300	326.0	1016.0	225	115	20
175 HM	200-3-60	187	220	6	649.0	1000	1329.0	—	800	115	20
	230-3-60	207	253	6	565.8	1000	1156.0	—	700	115	20
	380-3-60	342	418	3	341.4	600	700.0	2179.0	450	115	20
	460-3-60	414	506	3	283.8	500	578.0	1800.0	350	115	20
	575-3-60	518	633	3	226.0	400	462.0	1440.0	300	115	20
185	200-3-60	187	220	6	578.5	1000	938.0	—	700	115	20
	230-3-60	207	253	6	501.6	800	816.0	—	700	115	20
	380-3-60	342	418	3	302.9	500	494.0	1537.0	400	115	20
	460-3-60	414	506	3	251.6	450	408.0	1270.0	350	115	20
	575-3-60	518	633	3	203.5	350	326.0	1016.0	250	115	20
185 HM	200-3-60	187	220	6	738.8	1200	1329.0	—	1000	115	20
	230-3-60	207	253	6	642.6	1000	1156.0	—	800	115	20
	380-3-60	342	418	6	389.4	700	700.0	2179.0	500	115	20
	460-3-60	414	506	3	322.1	500	578.0	1800.0	400	115	20
	575-3-60	518	633	3	258.0	450	462.0	1440.0	350	115	20
200	200-3-60	187	220	6	578.5	1000	938.0	—	700	115	20
	230-3-60	207	253	6	501.6	800	816.0	—	700	115	20
	380-3-60	342	418	3	302.9	500	494.0	1537.0	400	115	20
	460-3-60	414	506	3	251.6	450	408.0	1270.0	350	115	20
	575-3-60	518	633	3	203.5	350	326.0	1016.0	250	115	20
200 HM	200-3-60	187	220	6	738.8	1200	1329.0	—	1000	115	20
	230-3-60	207	253	6	642.6	1000	1156.0	—	800	115	20
	380-3-60	342	418	6	389.4	700	700.0	2179.0	500	115	20
	460-3-60	414	506	3	322.1	500	578.0	1800.0	400	115	20
	575-3-60	518	633	3	258.0	450	462.0	1440.0	350	115	20
225	200-3-60	187	220	6	687.5	1200	1329.0	—	1000	115	20
	230-3-60	207	253	6	597.8	1000	1156.0	—	800	115	20
	380-3-60	342	418	3	360.6	600	700.0	2179.0	450	115	20
	460-3-60	414	506	3	299.6	500	578.0	1800.0	400	115	20
	575-3-60	518	633	3	238.8	400	462.0	1440.0	300	115	20
225 HM	200-3-60	187	220	—	—	—	—	—	—	—	—
	230-3-60	207	253	—	—	—	—	—	—	—	—
	380-3-60	342	418	3	472.8	800	758.0	—	600	115	20
	460-3-60	414	506	3	389.4	700	625.0	1906.0	500	115	20
	575-3-60	518	633	3	309.3	500	498.0	1521.0	400	115	20

LEGEND

- HM — Heat Machine Units
- ICF — Maximum Instantaneous Current Flow
- LRA — Locked Rotor Amps
- MCA — Minimum Circuit Ampacity (for wire sizing)
- MOCP — Maximum Overcurrent Protection
- RLA — Rated Load Amps
- WD — Wye-Delta Start
- XL — Across-the-Line Start

NOTES:

1. Each main power source must be supplied from a field-supplied fused electrical service with a (factory-installed or field-installed) disconnect located in sight from the unit.
2. Control circuit power must be supplied from a separate source through a field-supplied disconnect. An optional control transformer may be used to provide control circuit power from the main unit power supply.

3. Maximum instantaneous current flow (ICF) during start-up is the point in the starting sequence where the sum of the LRA for the start-up compressor, plus the total RLA for all running compressors is at a maximum.
4. Maximum incoming wire size for each terminal block is 500 kcmil.
5. Maximum allowable phase imbalance is: voltage, 2%; amps, 5%.
6. Use copper conductors only.
7. The MOCP is calculated as follows:
 $MOCP = (2.25) (\text{largest RLA}) + \text{the sum of the other RLAs}$. Size the fuse one size down from the result. The RLAs are listed on nameplate. The recommended fuse size in amps (RFA) is calculated as follows:
 $RFA = (1.50) (\text{largest RLA}) + \text{the sum of the other RLAs}$. Size the fuse one size up from the result. The RLAs are listed on the nameplate.



STANDARD SINGLE INPUT POWER CONFIGURATION (cont)

30XW UNIT SIZE	UNIT VOLTAGE			NO. POWER SUPPLY CONDUCTORS	MCA	MOCP	ICF		REC FUSE SIZE	CONTROL CIRCUIT	
	V-Ph-Hz	Supplied					WD	XL		VOLTAGE 1 PH, 60 Hz	MCA and MOCP
		Min	Max								
250	200-3-60	187	220	6	687.5	1200	1329.0	—	1000	115	20
	230-3-60	207	253	6	597.8	1000	1156.0	—	800	115	20
	380-3-60	342	418	3	360.6	600	700.0	2179.0	450	115	20
	460-3-60	414	506	3	299.6	500	578.0	1800.0	400	115	20
	575-3-60	518	633	3	238.8	400	462.0	1440.0	300	115	20
250 HM	200-3-60	187	220	—	—	—	—	—	—	—	—
	230-3-60	207	253	—	—	—	—	—	—	—	—
	380-3-60	342	418	3	472.8	800	758.0	—	600	115	20
	460-3-60	414	506	3	389.4	700	625.0	1906.0	500	115	20
	575-3-60	518	633	3	309.3	500	498.0	1521.0	400	115	20
260	200-3-60	187	220	9	761.3	1200	1329.0	—	1000	115	20
	230-3-60	207	253	6	661.9	1000	1156.0	—	800	115	20
	380-3-60	342	418	6	399.0	700	700.0	2179.0	500	115	20
	460-3-60	414	506	3	331.8	500	578.0	1800.0	400	115	20
	575-3-60	518	633	3	264.4	450	462.0	1440.0	350	115	20
260 HM	200-3-60	187	220	—	—	—	—	—	—	—	—
	230-3-60	207	253	—	—	—	—	—	—	—	—
	380-3-60	342	418	6	524.0	800	758.0	—	700	115	20
	460-3-60	414	506	3	431.1	700	625.0	1906.0	600	115	20
	575-3-60	518	633	3	344.5	600	498.0	1521.0	450	115	20
275	200-3-60	187	220	9	761.3	1200	1329.0	—	1000	115	20
	230-3-60	207	253	6	661.9	1000	1156.0	—	800	115	20
	380-3-60	342	418	6	399.0	700	700.0	2179.0	500	115	20
	460-3-60	414	506	3	331.8	500	578.0	1800.0	400	115	20
	575-3-60	518	633	3	264.4	450	462.0	1440.0	350	115	20
275 HM	200-3-60	187	220	—	—	—	—	—	—	—	—
	230-3-60	207	253	—	—	—	—	—	—	—	—
	380-3-60	342	418	6	524.0	800	758.0	—	700	115	20
	460-3-60	414	506	3	431.1	700	625.0	1906.0	600	115	20
	575-3-60	518	633	3	344.5	600	498.0	1521.0	450	115	20
300	200-3-60	187	220	9	812.5	1200	1329.0	—	1000	115	20
	230-3-60	207	253	6	706.8	1200	1156.0	—	1000	115	20
	380-3-60	342	418	6	427.9	700	700.0	2179.0	600	115	20
	460-3-60	414	506	3	354.1	600	578.0	1800.0	450	115	20
	575-3-60	518	633	3	280.5	500	462.0	1440.0	350	115	20
300 HM	200-3-60	187	220	—	—	—	—	—	—	—	—
	230-3-60	207	253	—	—	—	—	—	—	—	—
	380-3-60	342	418	6	556.1	1000	758.0	—	700	115	20
	460-3-60	414	506	3	459.9	800	625.0	1906.0	600	115	20
	575-3-60	518	633	3	367.0	600	498.0	1521.0	450	115	20
325	200-3-60	187	220	9	920.3	1200	1347.0	—	1200	115	20
	230-3-60	207	253	9	799.0	1000	1171.1	—	1000	115	20
	380-3-60	342	418	6	487.6	700	710.7	1753.7	600	115	20
	460-3-60	414	506	6	401.0	500	586.2	1448.2	450	115	20
	575-3-60	518	633	3	317.3	450	467.0	1157.0	400	115	20
325 HM	200-3-60	187	220	12	1168.2	1600	1848.2	—	1600	115	20
	230-3-60	207	253	9	1018.4	1200	1608.6	—	1200	115	20
	380-3-60	342	418	6	614.5	800	973.1	2452.1	700	115	20
	460-3-60	414	506	6	510.8	700	805.0	2027.0	600	115	20
	575-3-60	518	633	6	406.8	500	642.8	1620.8	500	115	20

LEGEND

- HM** — Heat Machine Units
- ICF** — Maximum Instantaneous Current Flow
- LRA** — Locked Rotor Amps
- MCA** — Minimum Circuit Ampacity (for wire sizing)
- MOCP** — Maximum Overcurrent Protection
- RLA** — Rated Load Amps
- WD** — Wye-Delta Start
- XL** — Across-the-Line Start

NOTES:

1. Each main power source must be supplied from a field-supplied fused electrical service with a (factory-installed or field-installed) disconnect located in sight from the unit.
2. Control circuit power must be supplied from a separate source through a field-supplied disconnect. An optional control transformer may be used to provide control circuit power from the main unit power supply.
3. Maximum instantaneous current flow (ICF) during start-up is the point in the starting sequence where the sum of the LRA for the

start-up compressor, plus the total RLA for all running compressors is at a maximum.

4. Maximum incoming wire size for each terminal block is 500 kcmil.
5. Maximum allowable phase imbalance is: voltage, 2%; amps, 5%.
6. Use copper conductors only.
7. The MOCP is calculated as follows:
 $MOCP = (2.25) (\text{largest RLA}) + \text{the sum of the other RLAs}$. Size the fuse one size down from the result. The RLAs are listed on nameplate. The recommended fuse size in amps (RFA) is calculated as follows:
 $RFA = (1.50) (\text{largest RLA}) + \text{the sum of the other RLAs}$. Size the fuse one size up from the result. The RLAs are listed on the nameplate.



STANDARD SINGLE INPUT POWER CONFIGURATION (cont)

30XW UNIT SIZE	UNIT VOLTAGE			NO. POWER SUPPLY CONDUCTORS	MCA	MOCP	ICF		REC FUSE SIZE	CONTROL CIRCUIT	
	V-Ph-Hz	Supplied					WD	XL		VOLTAGE 1 PH, 60 Hz	MCA and MOCP
		Min	Max								
350	200-3-60	187	220	9	920.3	1200	1347.0	—	1200	115	20
	230-3-60	207	253	9	799.0	1000	1171.1	—	1000	115	20
	380-3-60	342	418	6	487.6	700	710.7	1753.7	600	115	20
	460-3-60	414	506	6	401.0	500	586.2	1448.2	450	115	20
	575-3-60	518	633	3	317.3	450	467.0	1157.0	400	115	20
350 HM	200-3-60	187	220	12	1168.2	1600	1848.2	—	1600	115	20
	230-3-60	207	253	9	1018.4	1200	1608.6	—	1200	115	20
	380-3-60	342	418	6	614.5	800	973.1	2452.1	700	115	20
	460-3-60	414	506	6	510.8	700	805.0	2027.0	600	115	20
	575-3-60	518	633	6	406.8	500	642.8	1620.8	500	115	20
375	200-3-60	187	220	9	1041.3	1200	1400.8	—	1200	115	20
	230-3-60	207	253	9	902.9	1200	1217.3	—	1200	115	20
	380-3-60	342	418	6	545.2	700	736.3	1779.3	700	115	20
	460-3-60	414	506	6	452.9	600	609.3	1471.3	600	115	20
	575-3-60	518	633	3	366.3	500	488.8	1178.8	450	115	20
375 HM	200-3-60	187	220	12	1329.8	1600	1920.0	—	1600	115	20
	230-3-60	207	253	12	1156.7	1600	1670.1	—	1600	115	20
	380-3-60	342	418	6	700.9	1000	1011.5	2490.5	800	115	20
	460-3-60	414	506	6	579.8	800	835.7	2057.7	700	115	20
	575-3-60	518	633	6	464.4	600	668.4	1646.4	600	115	20
400	200-3-60	187	220	9	1041.3	1200	1400.8	—	1200	115	20
	230-3-60	207	253	9	902.9	1200	1217.3	—	1200	115	20
	380-3-60	342	418	6	545.2	700	736.3	1779.3	700	115	20
	460-3-60	414	506	6	452.9	600	609.3	1471.3	600	115	20
	575-3-60	518	633	3	366.3	500	488.8	1178.8	450	115	20
400 HM	200-3-60	187	220	12	1329.8	1600	1920.0	—	1600	115	20
	230-3-60	207	253	12	1156.7	1600	1670.1	—	1600	115	20
	380-3-60	342	418	6	700.9	1000	1011.5	2490.5	800	115	20
	460-3-60	414	506	6	579.8	800	835.7	2057.7	700	115	20
	575-3-60	518	633	6	464.4	600	668.4	1646.4	600	115	20

LEGEND

- HM** — Heat Machine Units
- ICF** — Maximum Instantaneous Current Flow
- LRA** — Locked Rotor Amps
- MCA** — Minimum Circuit Ampacity (for wire sizing)
- MOCP** — Maximum Overcurrent Protection
- RLA** — Rated Load Amps
- WD** — Wye-Delta Start
- XL** — Across-the-Line Start

NOTES:

1. Each main power source must be supplied from a field-supplied fused electrical service with a (factory-installed or field-installed) disconnect located in sight from the unit.
2. Control circuit power must be supplied from a separate source through a field-supplied disconnect. An optional control transformer may be used to provide control circuit power from the main unit power supply.
3. Maximum instantaneous current flow (ICF) during start-up is the point in the starting sequence where the sum of the LRA for the

start-up compressor, plus the total RLA for all running compressors is at a maximum.

4. Maximum incoming wire size for each terminal block is 500 kcmil.
5. Maximum allowable phase imbalance is: voltage, 2%; amps, 5%.
6. Use copper conductors only.
7. The MOCP is calculated as follows:

MOCP = (2.25) (largest RLA) + the sum of the other RLAs. Size the fuse one size down from the result. The RLAs are listed on nameplate. The recommended fuse size in amps (RFA) is calculated as follows:
 RFA = (1.50) (largest RLA) + the sum of the other RLAs. Size the fuse one size up from the result. The RLAs are listed on the nameplate.



OPTIONAL DUAL INPUT POWER CONFIGURATION

30XW UNIT SIZE	UNIT VOLTAGE			NO. POWER SUPPLY CONDUCTORS	MCA	MOCP	ICF		REC FUSE SIZE		CONTROL CIRCUIT	
	V-Ph-Hz	Supplied					WD	XL			V-Ph-Hz	MCA and MOCP
		Min	Max									
325	200-3-60	187	220	6/6	511.3/511.3	800/800	938/938	—	700	700	115-1-60	20
	230-3-60	207	253	6/6	443.9/443.9	700/700	816/816	—	600	600	115-1-60	20
	380-3-60	342	418	3/3	270.9/270.9	450/450	494/494	1537/1537	350	350	115-1-60	20
	460-3-60	414	506	3/3	222.8/222.8	400/400	408/408	1270/1270	300	300	115-1-60	20
	575-3-60	518	633	3/3	176.3/176.3	300/300	326/326	1016/1016	225	225	115-1-60	20
325 HM	200-3-60	187	220	6/6	649.0/649.0	1000/1000	1329/1329	—	800	800	115-1-60	20
	230-3-60	207	253	6/6	565.8/565.8	1000/1000	1156/1156	—	700	700	115-1-60	20
	380-3-60	342	418	3/3	341.4/341.4	600/600	700/700	2179/2179	450	450	115-1-60	20
	460-3-60	414	506	3/3	283.8/283.8	500/500	578/578	1800/1800	350	350	115-1-60	20
	575-3-60	518	633	3/3	226.0/226.0	400/400	462/462	1440/1440	300	300	115-1-60	20
350	200-3-60	187	220	6/6	511.3/511.3	800/800	938/938	—	700	700	115-1-60	20
	230-3-60	207	253	6/6	443.9/443.9	700/700	816/816	—	600	600	115-1-60	20
	380-3-60	342	418	3/3	270.9/270.9	450/450	494/494	1537/1537	350	350	115-1-60	20
	460-3-60	414	506	3/3	222.8/222.8	400/400	408/408	1270/1270	300	300	115-1-60	20
	575-3-60	518	633	3/3	176.3/176.3	300/300	326/326	1016/1016	225	225	115-1-60	20
350 HM	200-3-60	187	220	6/6	649.0/649.0	1000/1000	1329/1329	—	800	800	115-1-60	20
	230-3-60	207	253	6/6	565.8/565.8	1000/1000	1156/1156	—	700	700	115-1-60	20
	380-3-60	342	418	3/3	341.4/341.4	600/600	700/700	2179/2179	450	450	115-1-60	20
	460-3-60	414	506	3/3	283.8/283.8	500/500	578/578	1800/1800	350	350	115-1-60	20
	575-3-60	518	633	3/3	226.0/226.0	400/400	462/462	1440/1440	300	300	115-1-60	20
375	200-3-60	187	220	6/6	578.5/578.5	1000/1000	938/938	—	700	700	115-1-60	20
	230-3-60	207	253	6/6	501.6/501.6	800/800	816/816	—	700	700	115-1-60	20
	380-3-60	342	418	3/3	302.9/302.9	500/500	494/494	1537/1537	400	400	115-1-60	20
	460-3-60	414	506	3/3	251.6/251.6	450/450	408/408	1270/1270	350	350	115-1-60	20
	575-3-60	518	633	3/3	203.5/203.5	350/350	326/326	1016/1016	250	250	115-1-60	20
375 HM	200-3-60	187	220	6/6	738.8/738.8	1200/1200	1329/1329	—	1000	1000	115-1-60	20
	230-3-60	207	253	6/6	642.6/642.6	1000/1000	1156/1156	—	800	800	115-1-60	20
	380-3-60	342	418	6/6	389.4/389.4	600/600	700/700	2179/2179	500	500	115-1-60	20
	460-3-60	414	506	3/3	322.1/322.1	500/500	578/578	1800/1800	400	400	115-1-60	20
	575-3-60	518	633	3/3	258.0/258.0	450/450	462/462	1440/1440	350	350	115-1-60	20
400	200-3-60	187	220	6/6	578.5/578.5	1000/1000	938/938	—	700	700	115-1-60	20
	230-3-60	207	253	6/6	501.6/501.6	800/800	816/816	—	700	700	115-1-60	20
	380-3-60	342	418	3/3	302.9/302.9	500/500	494/494	1537/1537	400	400	115-1-60	20
	460-3-60	414	506	3/3	251.6/251.6	450/450	408/408	1270/1270	350	350	115-1-60	20
	575-3-60	518	633	3/3	203.5/203.5	350/350	326/326	1016/1016	250	250	115-1-60	20
400 HM	200-3-60	187	220	6/6	738.8/738.8	1200/1200	1329/1329	—	1000	1000	115-1-60	20
	230-3-60	207	253	6/6	642.6/642.6	1000/1000	1156/1156	—	800	800	115-1-60	20
	380-3-60	342	418	6/6	389.4/389.4	600/600	700/700	2179/2179	500	500	115-1-60	20
	460-3-60	414	506	3/3	322.1/322.1	500/500	578/578	1800/1800	400	400	115-1-60	20
	575-3-60	518	633	3/3	258.0/258.0	450/450	462/462	1440/1440	350	350	115-1-60	20

LEGEND

- HM — Heat Machine Units
- ICF — Maximum Instantaneous Current Flow
- LRA — Locked Rotor Amps
- MCA — Minimum Circuit Ampacity (for wire sizing)
- MOCP — Maximum Overcurrent Protection
- RLA — Rated Load Amps
- WD — Wye-Delta Start
- XL — Across-the-Line Start

4. Maximum incoming wire size for each terminal block is 500 kcmil.
5. Maximum allowable phase imbalance is: voltage, 2%; amps, 5%.
6. Use copper conductors only.
7. The MOCP is calculated as follows:
 $MOCP = (2.25) (\text{largest RLA}) + \text{the sum of the other RLAs}$. Size the fuse one size down from the result. The RLAs are listed on the nameplate.
 The recommended fuse size in amps (RFA) is calculated as follows:
 $RFA = (1.50) (\text{largest RLA}) + \text{the sum of the other RLAs}$. Size the fuse one size up from the result. The RLAs are listed on the nameplate.

NOTES:

1. Each main power source must be supplied from a field-supplied fused electrical service with a (factory-installed or field-installed) disconnect located in sight from the unit.
2. Control circuit power must be supplied from a separate source through a field-supplied disconnect. An optional control transformer may be used to provide control circuit power from the main unit power supply.
3. Maximum instantaneous current flow (ICF) during start-up is the point in the starting sequence where the sum of the LRA for the start-up compressor, plus the total RLA for all running compressors is at a maximum.



COMPRESSOR ELECTRICAL DATA

30XW UNIT SIZE	VOLTAGE V-Ph-Hz	COMPRESSOR	COMPRESSOR A			COMPRESSOR B (SIZES 325-400 ONLY)		
			RLA	LRA (WD)	LRA (XL)	RLA	LRA (WD)	LRA (XL)
150, 325	200-3-60	06TU483	409.0	938	—	409.0	938	—
	230-3-60	06TU483	355.1	816	—	355.1	816	—
	380-3-60	06TU483	216.7	494	1537	216.7	494	1537
	460-3-60	06TU483	178.2	408	1270	178.2	408	1270
	575-3-60	06TU483	141.0	326	1016	141.0	326	1016
150, 325 HM	200-3-60	06TU483	519.2	1329	—	519.2	1329	—
	230-3-60	06TU483	452.6	1156	—	452.6	1156	—
	380-3-60	06TU483	273.1	700	2179	273.1	700	2179
	460-3-60	06TU483	227.0	578	1800	227.0	578	1800
	575-3-60	06TU483	180.8	462	1440	180.8	462	1440
175, 350	200-3-60	06TU483	409.0	938	—	409.0	938	—
	230-3-60	06TU483	355.1	816	—	355.1	816	—
	380-3-60	06TU483	216.7	494	1537	216.7	494	1537
	460-3-60	06TU483	178.2	408	1270	178.2	408	1270
	575-3-60	06TU483	141.0	326	1016	141.0	326	1016
175, 350 HM	200-3-60	06TU483	519.2	1329	—	519.2	1329	—
	230-3-60	06TU483	452.6	1156	—	452.6	1156	—
	380-3-60	06TU483	273.1	700	2179	273.1	700	2179
	460-3-60	06TU483	227.0	578	1800	227.0	578	1800
	575-3-60	06TU483	180.8	462	1440	180.8	462	1440
185, 200, 375, 400	200-3-60	06TU554	462.8	938	—	462.8	938	—
	230-3-60	06TU554	401.3	816	—	401.3	816	—
	380-3-60	06TU554	242.3	494	1537	242.3	494	1537
	460-3-60	06TU554	201.3	408	1270	201.3	408	1270
	575-3-60	06TU554	162.8	326	1016	162.8	326	1016
185, 200, 375, 400 HM	200-3-60	06TU554	591.0	1329	—	588.5	1329	—
	230-3-60	06TU554	514.1	1156	—	512.8	1156	—
	380-3-60	06TU554	311.5	700	2179	309.0	700	2179
	460-3-60	06TU554	257.7	578	1800	256.4	578	1800
	575-3-60	06TU554	206.4	462	1440	203.8	462	1440
225, 250	200-3-60	06TV680	550.0	1329	—	—	—	—
	230-3-60	06TV680	478.2	1156	—	—	—	—
	380-3-60	06TV680	288.5	700	2179	—	—	—
	460-3-60	06TV680	239.7	578	1800	—	—	—
	575-3-60	06TV680	191.0	462	1440	—	—	—
225, 250 HM	200-3-60	06TV680	—	—	—	—	—	—
	230-3-60	06TV680	—	—	—	—	—	—
	380-3-60	06TV680	378.2	758	—	—	—	—
	460-3-60	06TV680	311.5	625	1906	—	—	—
	575-3-60	06TV680	247.4	498	1521	—	—	—
260, 275	200-3-60	06TV753	609.0	1329	—	—	—	—
	230-3-60	06TV753	529.5	1156	—	—	—	—
	380-3-60	06TV753	319.2	700	2179	—	—	—
	460-3-60	06TV753	265.4	578	1800	—	—	—
	575-3-60	06TV753	211.5	462	1440	—	—	—
260, 275 HM	200-3-60	06TV753	—	—	—	—	—	—
	230-3-60	06TV753	—	—	—	—	—	—
	380-3-60	06TV753	419.2	758	—	—	—	—
	460-3-60	06TV753	344.9	625	1906	—	—	—
	575-3-60	06TV753	275.6	498	1521	—	—	—
300	200-3-60	06TV819	650.0	1329	—	—	—	—
	230-3-60	06TV819	565.4	1156	—	—	—	—
	380-3-60	06TV819	342.3	700	2179	—	—	—
	460-3-60	06TV819	283.3	578	1800	—	—	—
	575-3-60	06TV819	224.4	462	1440	—	—	—
300 HM	200-3-60	06TV819	—	—	—	—	—	—
	230-3-60	06TV819	—	—	—	—	—	—
	380-3-60	06TV819	444.9	758	—	—	—	—
	460-3-60	06TV819	367.9	625	1906	—	—	—
	575-3-60	06TV819	293.6	498	1521	—	—	—

LEGEND
HM — Heat Machine Units **WD** — Wye-Delta Start
LRA — Locked Rotor Amps **XL** — Across-the-Line Start
RLA — Rated Load Amps

Water-Cooled Chiller

HVAC Guide Specifications

Size Range: **150 to 400 Nominal Tons**
(528 to 1407 kW)

Carrier Model Number: **30XW**

Part 1 — General

1.01 SYSTEM DESCRIPTION

Microprocessor controlled water-cooled liquid chiller utilizing screw compressor(s) and electronic expansion valves.

1.02 QUALITY ASSURANCE

- A. Unit shall be rated in accordance with AHRI (Air-Conditioning, Heating, and Refrigeration Institute) Standard 550/590 (U.S.A.), latest edition.
- B. Unit construction shall comply with ASHRAE (American Society of Heating, Refrigerating, and Air-Conditioning Engineers) 90.1 2010 15 Safety Code, NEC (National Electrical Code), and ASME (American Society of Mechanical Engineers) applicable codes (U.S.A. codes).
- C. Unit shall be manufactured in a facility registered to ISO (International Organization for Standardization) 9001 Manufacturing Quality Standard.
- D. 200-v, 230-v, 460-v, 575-v, 60 Hz units shall be constructed in accordance with UL (Underwriters Laboratories) or UL Canada standards and shall be tested and listed by ETL or ETL, Canada, as conforming to those standards. Units shall carry the ETL and ETL, Canada, labels.

1.03 DELIVERY, STORAGE, AND HANDLING

- A. Unit controls shall be capable of withstanding 150°F (65.5°C) storage temperatures in the control compartment.
- B. Chiller and starter should be stored indoors, protected from construction dirt and moisture. An inspection should be conducted under shipping tarps, bags, or crates to be sure water has not collected during transit. Protective shipping covers should be kept in place until machine is ready for installation. The inside of the protective cover should meet the following criteria:
 1. Temperature is between 40°F (4.4°C) and 120°F (48.9°C).
 2. Relative humidity is between 10% and 80% (non-condensing).

Part 2 — Products

2.01 EQUIPMENT

A. General:

Factory assembled, single-piece, water-cooled liquid chiller. Unit sizes 325-400 shall have dual (2) independent refrigerant circuits. Contained within the unit cabinet shall be all factory wiring, piping, controls, refrigerant charge (HFC-134a) and special features required prior to field start-up.

B. Compressor(s):

1. Semi-hermetic twin-screw compressor(s) with internal muffler and check valve.
2. Each compressor shall be equipped with a discharge shutoff valve.

C. Evaporator:

1. Shall be tested and stamped in accordance with ASME Code (U.S.A.) for a refrigerant working-side pressure of 220 psig (1408 kPa). Water-side pressure rating shall be 150 psig (1034 kPa). In Canada, maximum water-side pressure shall be 250 psig (1725 kPa), per the Canadian National Registry.
2. Shall be mechanically cleanable shell-and-tube type with removable heads.
3. Tubes shall be internally enhanced, seamless-copper type, and shall be rolled into tube sheets.
4. Shall be equipped with Victaulic fluid connections (2 pass) or flanged fluid connections (1, 2 or 3 pass).
5. Shell shall be insulated with $\frac{3}{4}$ -in. (19-mm) closed-cell, polyvinyl chloride foam with a maximum K factor of 0.28. Heads may require field insulation.
6. Shall have an evaporator drain and vent.
7. Design shall incorporate 2 independent refrigerant circuits (sizes 325-400 only).
8. Shall be equipped with factory-installed thermal dispersion chilled fluid flow switch.

D. Condenser:

1. Shall be tested and stamped in accordance with ASME code (U.S.A.) for a refrigerant working-side pressure of 220 psig (1408 kPa). Water-side pressure rating shall be 150 psig (1034 kPa). In Canada, maximum water-side pressure shall be 250 psig (1725 kPa), per the Canadian National Registry.
2. Shall be mechanically cleanable shell-and-tube type with removable heads.
3. Tubes shall be internally enhanced, seamless-copper type, and shall be rolled into tube sheets.
4. Shall be equipped with Victaulic water connections.
5. Unit sizes 325-400 shall have dual (2) independent refrigerant circuits.

E. Heat Machines:

1. Condenser shall be tested and stamped in accordance with ASME Code (U.S.A.) for a refrigerant working-side pressure of 300 psig (2068 kPa).
2. Unit sizes 325-400 shall have dual (2) independent refrigerant circuits.
3. Heat machine condensers shall include factory-installed thermal insulation on the condenser,

condenser flow switch and leaving water temperature sensor. Heat machine units require field-installed thermal insulation on the compressor discharge piping and waterbox heads because of high temperature.

F. Refrigeration Components:

Refrigerant circuit components shall include oil separator, high and low side pressure relief devices, liquid line shutoff valves, filter drier, moisture indicating sight glass, expansion valve, refrigerant economizer (unit sizes 175, 200, 250, 275, 300, 350, 400), and complete charge of compressor oil. The units shall have a complete operating charge of refrigerant HFC-134a.

G. Controls:

1. Unit controls shall include the following minimum components:
 - a. Microprocessor with non-volatile memory. Battery backup system shall not be accepted.
 - b. Separate terminal block for power and controls.
 - c. Separate 115-v power supply to serve all controllers, relays, and control components.
 - d. ON/OFF control switch.
 - e. Replaceable solid-state controllers.
 - f. Pressure sensors installed to measure suction, oil, economizer (unit sizes 175, 200, 250, 275, 300, 350, 400), and discharge pressure. Thermistors installed to measure evaporator entering and leaving fluid temperatures.
2. Unit controls shall include the following functions:
 - a. Automatic circuit lead/lag.
 - b. Capacity control based on leaving chilled fluid temperature and compensated by rate of change of return-fluid temperature with temperature set point accuracy to 0.1°F (0.05°C).
 - c. Limiting the chilled fluid temperature pulldown rate at start-up to an adjustable range of 0.2°F to 2°F (0.1 to 1.1°C) per minute to prevent excessive demand spikes at start-up.
 - d. Seven-day time schedule.
 - e. Leaving chilled fluid temperature reset from return fluid.
 - f. Chilled water and condenser water pump start/stop control.
 - g. Chiller control for parallel chiller applications without addition of hardware modules and control panels (requires thermistors).
 - h. Single step demand limit control activated by remote contact closure.

H. Safeties:

Unit shall be equipped with thermistors and all necessary components in conjunction with the control system to provide the unit with the following protections:

1. Loss of refrigerant charge.
2. Reverse rotation.
3. Low chilled fluid temperature.
4. Motor overtemperature.
5. High pressure.
6. Electrical overload.
7. Loss of phase.
8. Loss of chilled water flow.

I. Diagnostics:

1. The control panel shall include, as standard, a display:
 - a. Touch screen display consisting of ¼ VGA LCD (liquid crystal display) with adjustable contrast and backlighting.
 - b. Display shall allow a user to navigate through menus, select desired options and modify data.
2. Features of the display shall include:
 - a. Display shall be customizable and allow up to 72 data points.
 - b. Display shall support both local equipment or network made for remote mount.
 - c. Display shall allow access to configuration, maintenance, service, set point, time schedules, alarm history and status data.
 - d. Display shall have one button for chiller on/off.
 - e. Display shall include three levels of password protection against unauthorized access to configuration and maintenance information, and display set up parameters.
 - f. Display shall allow for easy connection of a portable hand held technician tool to access information and upload and/or download chiller settings.
 - g. Display shall be compatible with the Carrier Comfort Network® (CCN) system and provide network alarm acknowledgment or indication and provide capability to fully monitor and control chiller.
 - h. Display alarms and parameters shall be capable of being displayed in full text.
 - i. Display shall be capable of displaying the last 50 alarms and will store a snapshot of a minimum of 20 status data parameters for each alarm.
 - j. Compressor run hours.
 - k. Compressor number of starts.
 - l. Compressor current.

m. Time of day:

- 1) Display module, in conjunction with the microprocessor, must also be capable of displaying the output (results) of a service test. Service test shall verify operation of every switch, thermistor, and compressor before chiller is started.
- 2) Diagnostics shall include the ability to review a list of the 30 most recent alarms with clear language descriptions of the alarm event. Display of alarm codes without the ability for clear language descriptions shall be prohibited.
- 3) An alarm history buffer shall allow the user to store no less than 30 alarm events with clear language descriptions, time and date stamp event entry.
- 4) The chiller controller shall include multiple connection ports for communicating with the local equipment network and the Carrier Comfort Network® (CCN) system.
- 5) The control system shall allow software upgrade without the need for new hardware modules.

J. Operating Characteristics:

Unit shall be capable of starting up with 95°F (35°C) entering fluid temperature to the evaporator.

K. Electrical Requirements:

1. Unit primary electrical power supply shall enter the unit at a single location.
2. Unit shall operate on 3-phase power at the voltage shown in the equipment schedule.
3. Control voltage shall be 115-v (60 Hz), single-phase, separate power supply.

L. Special Features:

Certain standard features are not applicable when the features designated by * are specified. For assistance in amending the specifications, contact your local Carrier Sales office.

* 1. Wye-Delta Starter:

Unit shall have a factory-installed, wye-delta starter to minimize electrical inrush current.

2. Vibration Isolation:

Unit shall be supplied with rubber-in-shear vibration isolators for field installation.

3. Control Power Transformer:

Unit shall be supplied with a factory-installed controls transformer that will supply 115-v control circuit power from the main unit power supply.

4. Temperature Reset Sensor:

Unit shall reset leaving chilled fluid temperature based on outdoor ambient temperature or space temperature when this sensor is installed.

* 5. Minimum Load Control:

Unit shall be equipped with factory-installed, microprocessor-controlled, minimum load control that shall permit unit operation down to 10% of full capacity.

6. One-Pass Evaporator:

Factory-installed option shall reduce pressure drop for high flow applications.

7. Three-Pass Evaporator:

Factory-installed option shall enhance performance for low flow applications.

8. Energy Management Module:

A factory or field installed module shall provide the following energy management capabilities: 4 to 20 mA signals for leaving fluid temperature reset, cooling set point reset or demand limit control; 2-point demand limit control (from 0 to 100%) activated by a remote contact closure; and discrete input for "Ice Done" indication for ice storage system interface.

9. BACnet Translator Control:

Unit shall be supplied with factory or field-installed interface between the chiller and a BACnet Local Area Network (LAN, i.e., MS/TP EIA-485).

10. LON Translator Control:

Unit shall be supplied with factory or field-installed interface between the chiller and a Local Operating Network (LON, i.e., LonWorks FT-10A ANSI/EIA-709.1).

11. Navigator™ Hand Held Portable Display:

- a. Portable hand held display module with a minimum of 4 lines and 20 characters per line, or clear English, Spanish, Portuguese or French language.
- b. Display menus shall provide clear language descriptions of all menu items, operating modes, configuration points and alarm diagnostics. Reference to factory codes shall not be accepted.
- c. RJ-14 connection plug shall allow display module to be connected to factory-installed receptacle.
- d. Industrial grade coiled extension cord shall allow the display module to be moved around the chiller.
- e. Magnets shall hold the display module to any sheet metal panel to allow hands-free operation.
- f. Display module shall have NEMA 4x housing.
- g. Display shall have back light and contrast adjustment for easy viewing in bright sunlight or night conditions.
- h. Raised surface buttons with positive tactile response.

12. Compressor Suction Service Valve:
Optional refrigerant discharge isolation and liquid valves enable service personnel to store the refrigerant charge in the evaporator or condenser during servicing. This factory-installed option allows for further isolation of the compressor from the evaporator vessel.
13. Refrigerant Isolation Valves:
Valves shall enable service personnel to store the refrigerant charge in the evaporator or condenser during servicing. During servicing, the in-chiller storage shall reduce refrigerant loss and eliminate time-consuming transfer procedures. As a self-contained unit, the chiller shall not require additional remote storage systems.
14. GFCI Convenience Outlet:
Shall be factory or field-installed and mounted with easily accessible 115-v female receptacle. Shall include 4 amp GFI (ground fault interrupt) receptacle.
15. Medium Temperature Brine:
Unit shall be factory modified to start and operate at leaving chilled fluid temperatures below 40°F (4.4°C). Chiller shall be equipped with condenser water flow switch. The optional insulation package is required when the medium temperature brine option is selected.
16. 300 psig (2068 kPa) Evaporator Operating Pressure:
This option shall provide for water-side pressure operation up to 300 psig (2068 kPa).
17. 300 psig (2068 kPa) Condenser Operating Pressure:
This option shall provide for water-side pressure operation up to 300 psig (2068 kPa).
18. Marine Waterboxes:
Marine waterboxes shall provide water piping connections extending from the side of the waterbox (as opposed to extending from the end of the waterbox). This option also includes a removable bolt on waterbox cover allowing access to the heat exchanger tubes without breaking the existing field piping. This option is available for both the evaporator and condenser.
19. Flanged Connection:
The flanged connection option shall provide an ANSI flange on the end of the chiller water piping for connection to a customer supplied mating flange in the field piping. This option is available for both the evaporator and condenser.
20. One-Pass Condenser:
This option shall provide a lower pressure drop through the condenser for applications with low delta T (temperature) or high flow or where the condensers are piped in a series. The one-pass condenser option is only available with flanged connections and with a suction end leaving water connection.
21. Three-Pass Condenser:
This option shall provide a greater efficiency for heat machine applications with a high delta T and low flow. The three-pass condenser option is only available with flanged connections and suction end leaving water connection.
22. Insulation Package:
Package shall provide 3/4-in. (19-mm) thermal insulation on compressor suction housing, and suction line.
23. Dual Point Power:
The dual point power option shall provide a means for connecting two sources of power to dual compressor chillers (sizes 325-400 only). One source of power is wired to operate the compressor on the A circuit and one source of power is wired to operate the compressor on the B circuit of the chiller.
24. Non-Fused Disconnect:
This option shall provide a no load, lockable, through the door handle disconnect for unit power on the chiller. On dual compressor units, two disconnects are provided (one for each compressor). On units with dual point power, one disconnect is provided for each of the two main power supplies. This disconnect does not remove the control circuit from power supply.
25. Nitrogen Charge:
A nitrogen charge option is available to provide a 15 psig (103.4 kPa) charge of nitrogen instead of a full factory charge of R-134a refrigerant to keep the chiller refrigerant circuit dry during shipment. This option is recommended for applications where the unit will be disassembled prior to installation. Units shipped with a nitrogen charge will receive an electrical continuity test at the factory prior to shipment.
26. Crate for Shipment:
This option is recommended for export orders. The chiller will be bagged prior to being placed in a wooden crate.
27. Remote Enhanced Display:
This option is a remotely mounted indoor 40-character per line, 16-line display panel for unit monitoring and diagnostics.
28. Vibration Springs:
A set of non-seismic spring isolators can be provided for installation at the jobsite.
29. BACnet¹ Communication Option:
Shall provide factory-installed communication capability with a BACnet MS/TP network. Allows integration with i-Vu[®] Open control system or a BACnet building automation system.

¹BACnet is a registered trademark of ASHRAE (American Society of Heating, Refrigerating and Air-Conditioning Engineers).

