

53DS-900-117 (115 v)  
 53DS-900-118 (230 v)

**Accessory Condensate Pump  
 for Ductless Split System  
 Cooling Only and Heat Pump High Wall Units  
 (Size 009-036)**

# Installation Instructions

**NOTE:** Read and become familiar with these instructions before beginning installation.

## SAFETY CONSIDERATIONS

Improper installation, adjustment, alteration, service, maintenance, or use can cause explosion, fire, electrical shock, or other conditions which may cause death, personal injury, or property damage. Consult a qualified installer, service agency, or your distributor or branch for information or assistance. The qualified installer or agency must use factory-authorized kits or accessories when modifying this product. Refer to the individual instructions packaged with the kits or accessories when installing.

Follow all safety codes. Wear safety glasses, protective clothing, and work gloves. Use quenching cloth for brazing operations. Have fire extinguisher available. Read these instructions thoroughly and follow all warnings or cautions included in literature and attached to the unit. Consult local building codes and current editions of the National Electrical Code (NEC) NFPA 70. In Canada, refer to current editions of the Canadian electrical code CSA 22.1.

Recognize safety information. This is the safety-alert symbol . When you see this symbol on the unit and in instructions or manuals, be alert to the potential for personal injury. Understand these signal words; DANGER, WARNING, and CAUTION. These words are used with the safety-alert symbol. DANGER identifies the most serious hazards which **will** result in severe personal injury or death. WARNING signifies hazards which **could** result in personal injury or death. CAUTION is used to identify unsafe practices which **would** result in minor personal injury or product and property damage. NOTE is used to highlight suggestions which **will** result in enhanced installation, reliability, or operation.

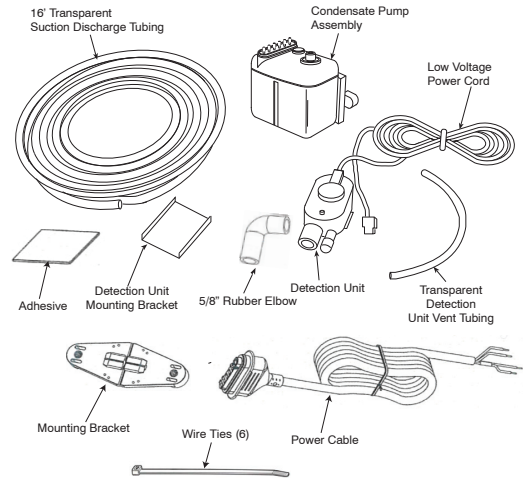

**Fig. 1 – Accessory Condensate Pump Kit**

A12227

**Table 1—Accessory Condensate Pump Kit Contents**

ITEM	QTY
<b>16-ft Transparent Suction/Discharge Tubing</b>	1
<b>Condensate Pump Assembly</b>	1
<b>Low-Voltage Power Cord</b>	1
<b>Transparent Detection Unit Vent Tubing</b>	1
<b>Power Cable</b>	1
<b>Wire Ties</b>	6
<b>Wall Mount Bracket</b>	1
<b>Adhesive</b>	1
<b>Detection Unit Mounting Bracket</b>	1
<b>5/8-in Rubber Elbow</b>	1
<b>Detection Unit</b>	1

## CAUTION

### UNIT OPERATION HAZARD

Failure to follow this caution may result in unit failure and/or damage.  
 Always follow instructions properly.

## WARNING

### ELECTRICAL SHOCK HAZARD

Failure to follow this warning could result in personal injury or death.

Before beginning any modification or installation of this kit, be sure the main electrical disconnect is in the OFF position. Ensure power is disconnected to the fan coil unit. On some systems both the fan coil and the outdoor unit may be on the same disconnect. Tag the disconnect switch with a suitable warning label. There may be more than one disconnect.

## GENERAL

Use the two-part accessory kit (condensate pump and detection unit) with high wall fan coils. The pump operates whenever the condensate level in the detection unit is high enough to cause the magnetic float switch to send a signal to start the pump.

The float switch in the detection unit also prevents overflow and can act as a safety device by shutting down the system. The detection unit comes with normally closed (NC) alarm contacts (user optional, but recommended). The normally closed alarm contact is a dry contact rated for 8 amps at 250 volts. In the event of a problem such as a clogged drain or pump discharge line, the alarm contact can be wired to shut down the entire system. The condensate pump provides 10 ft (3.0 m) maximum suction lift (A)-Fig. 2.

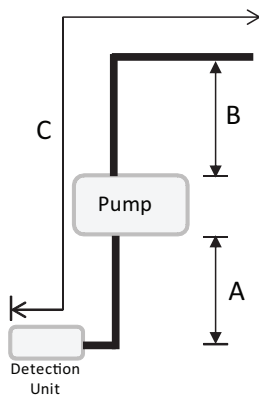

Fig. 2 – Maximum Lengths

A12134

Table 2—Accessory Package Usage

BASE UNIT	ACCESSORY MODEL NUMBER	
	53DS-900---117 (115-1-60)	53DS-900---118 (208/230-1-60)
	WIRING FIG. NO.	WIRING FIG. NO.
40GXC(Q)009---1	11	
40GXC(Q)012---1	11	
40GXC(Q)018---3	15	13
40GXC(Q)024---3	15	13
40GXM009---3	15	13
40GXM012---3	15	13
40GXM018---3	15	13
40MVC(Q)009---1	8	
40MVC(Q)012---1	8	
40MVC(Q)012---3	9 or 10	12
40MVC(Q)018---3	10	13
40MVC(Q)024---3	10	13
40QNC(Q)030---3		14
40QNC(Q)036---3		14
40QNC018024---3		14
40QNC018---3		14
40QNC024---3		14
PW3C(H)AM009	8	
PW3C(H)AM012	8	
PW3C(H)NM018	10	13
PW3C(H)NM024	10	13
RAS-09LKV-UL	15	16
RAS-12LKV-UL	15	16
RAS-15LKV-UL	15	16
RAS-17LKV-UL	15	16
RAS-22LKV-UL	15	16
RAV-SP180KRT-UL	15	16
RAV-SP240KRT-UL	15	16

## INSTALLATION

Refer to Fig. 1 and Table 1 for kit content.

**NOTE:** To make the installation easier, install the detection unit assembly before installing the fan coil unit.

- Unpack the contents of the condensate pump accessory package. Attach the 5/8-in. rubber elbow and transparent vent tubing to the detection unit (see Fig. 6). If straight connection is required, rubber elbow can be cut to size. Do not use a tube longer than the one supplied with the kit (2.95" / 75 mm). Slide the mounting bracket onto the bottom of the detection unit. Uncoil the low voltage power cord.
- Remove the fan coil mounting bracket from the back of the unit. Connect the detection unit with the 5/8-in. elbow, to the condensate drain line (see Fig. 6).
- Peel the adhesive cover on the back of the detection unit mounting bracket and attach it to the inside of the unit adjacent to the fan coil drain as shown in Fig. 6. **Make sure the detection is installed horizontally for proper operation of the float switch.**
- Attach one end of the transparent tubing to the detection unit. The tube can be connected to either the front or the rear as shown in Fig. 3. block the unused outlet with the plug supplied.

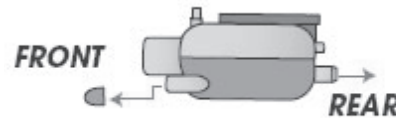

Fig. 3 – Detection Unit

A09398

- Connect one end of the low voltage power cord to the telephone jack socket in the detection unit and route the cord and transparent drain tubing through the knockout on the side of the unit enclosure (see Fig. 6).
- Determine the mounting location of the pump assembly. **The pump assembly must always be above the level of the detection unit.** For best operation, it is recommended that the pump assembly be mounted in a vertical position with the flow arrow on the pump pointing up (see Fig. 7). **Do not exceed 10 ft. (3.0 m) maximum suction lift.**

**NOTE:** in most applications, the pump will need to be mounted outside of the highwall unit for proper orientation ( i.e. above drop ceiling).

- Screw the bracket to the wall and attach the pump to the bracket as shown in Fig. 4 and Fig. 5.

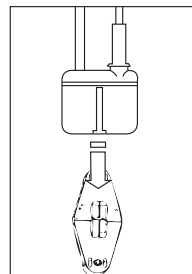

Fig. 4 – Pump Assembly Vertical

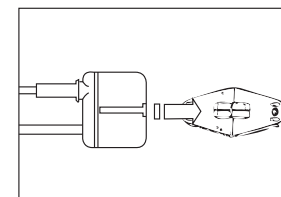

Fig. 5 – Pump Assembly Horizontal

A12228

If the pump is not mounted in the vertical position, make sure that plug on the pump is above the refrigerant tubing. This is required to avoid water leaking onto the pump causing a short circuit. **The pump cannot be splashed nor located in a damp environment.**

8. Connect the other end of the low voltage power cord from the detection unit to the telephone jack socket in the pump assembly.
9. Cut the suction, transparent drain tubing after determining where it will connect to the inlet side of the pump mounted on the wall. Remove the cap on the pump inlet and connect draining tubing.
10. Attach the remaining transparent tubing to the discharge side of the pump. Keep the pipe vertical for at least 4 or 5 inches and do not exceed the 33 ft (10 m) limit or the value shown in (B) of Table 3 and Table 4. **In order to avoid siphoning action and running the pump dry, always connect the discharge tube to the drain at a higher level than the pump itself (pump should be higher than detection unit).** Be sure the condensate is discharged to a safe location where the presence of water does not pose any safety or health hazards.
11. Install the transparent vent tube (provided) on top of the detection unit. Route tube so it will stay vertical (see Fig. 6).
12. Wire the pump and the alarm circuit using the appropriate wiring diagram listed in Table 2.
13. Prime the pump at start-up and after each maintenance operation. To ensure proper operation, the suction pipe and part of the discharge pipe must be slowly filled with water using a squeeze bottle.
14. Test the unit. When the unit is mounted in place, the condensate pump system must be tested.
  - a. Be sure the Hi-Wall unit is installed on a level plane. Remove the front cover of the unit.
  - b. Slowly fill the condensate drain pan with water. Observe the pump discharge tubing to be sure that the pump is operating. If condensate is not being discharged through the discharge tubing, check to be sure that the lines are not kinked or obstructed, and installation parameters have been followed. If the optional alarm contact is wired, continue to pour water until the alarm circuit triggers.

**Table 3—True Flow Rates (Gallons / Hr)**

53DS-900 -- 117, 118 Condensate Pump Flow Rates					
Refer to Fig. 2 for (A), (B), (C)		Total tube length, 1/4" flexible hose (C) ft			
Suction Head (A) ft	Discharge Head (B) ft	15	30	60	100
0	0	5.0	4.7	4.5	4.2
	6	4.2	3.9	3.7	3.5
	13	3.0	2.9	2.8	2.6
	20		2.5	2.0	1.7
	26		1.6	1.3	1.1
	33		1.1	0.9	0.7
3.3	0	3.7	3.4	3.2	2.9
	6	2.9	2.6	2.4	2.1
	13	0.5	1.8	1.6	1.3
	20		1.2	1.1	
6.6	0	2.9	2.6	2.4	2.1
	6	2.4	2.1	1.8	1.6
	13		1.5	1.3	1.2
10	0	2.6	2.4	2.1	1.8
	6	2.1	1.8	1.6	1.3
	13		1.3	1.1	

**Table 4—True Flow Rates (Liters / Hr)**

53DS-900 -- 117, 118 Condensate Pump Flow Rates					
Refer to Fig. 2 for (A), (B), (C)		Total tube length, 1/4" flexible hose (C) ft			
Suction Head (A) ft	Discharge Head (B) ft	15	30	60	100
0	0	18.9	17.8	17.0	15.9
	6	15.9	14.8	14.0	13.2
	13	11.4	11.0	10.6	9.8
	20		9.5	7.6	6.4
	26		6.1	4.9	4.2
	33		4.2	3.4	2.6
3.3	0	14.0	12.9	12.1	11.0
	6	11.0	9.8	9.1	7.9
	13	1.9	6.8	6.1	4.9
	20		4.5	4.2	
6.6	0	11.0	9.8	9.1	7.9
	6	9.1	7.9	6.8	6.1
	13	0.0	5.7	4.9	4.5
10	0	9.8	9.1	7.9	6.8
	6	7.9	6.8	6.1	4.9
	13		4.9	4.2	

**NOTE:** Maximum suction plus discharge head is 33 ft (10 m). Longer lengths indicate horizontal condition.

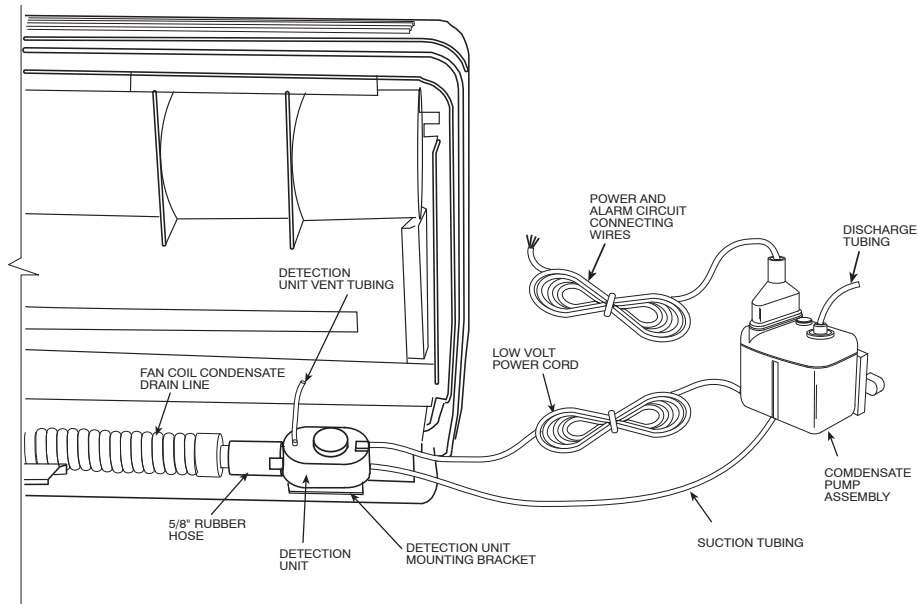

A12229

**Fig. 6 – Rear of High Wall Unit with Mounted Condensate Pump**

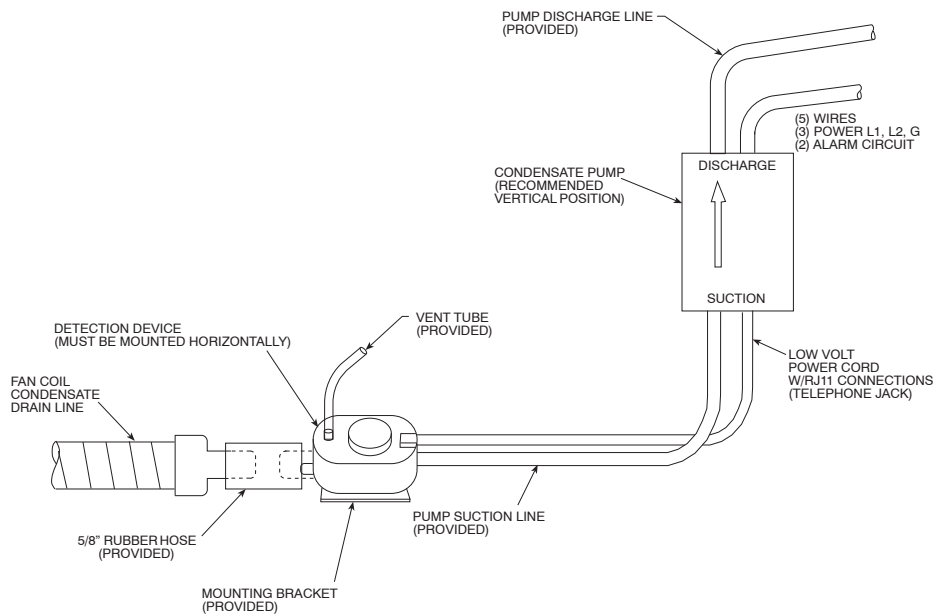

A12230

**Fig. 7 – Accessory Condensate Pump Connections**

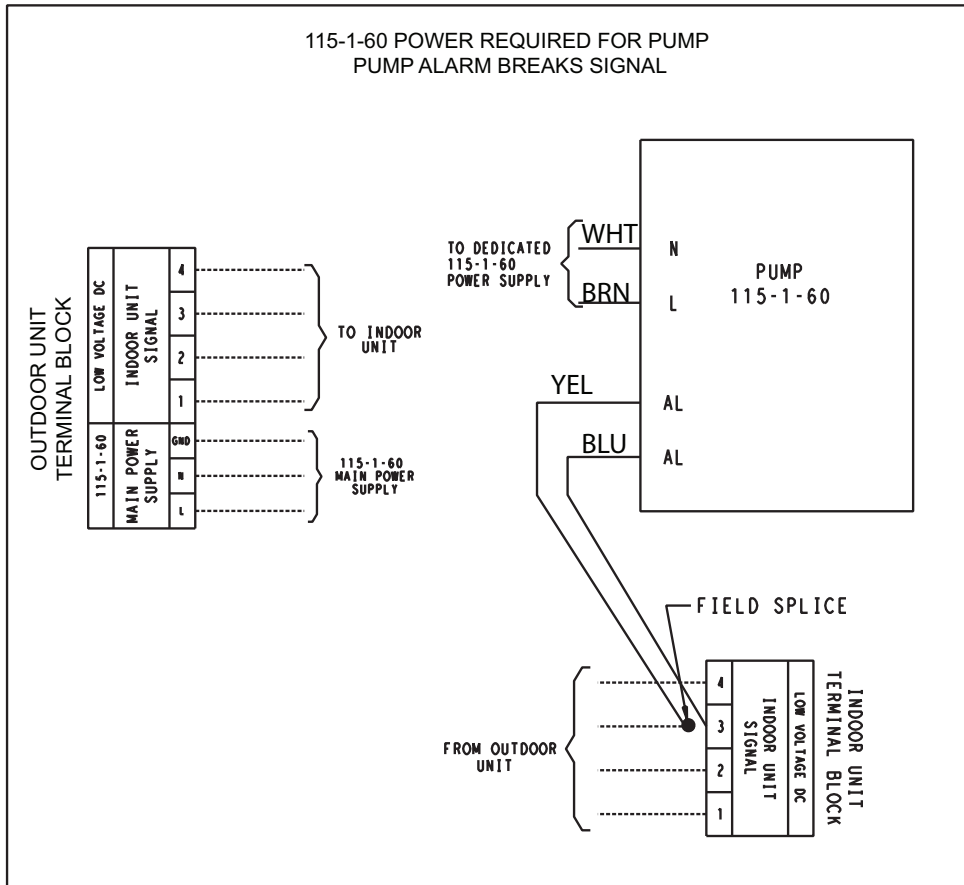

Fig. 8 – 009, 012 (115-1-60) WIRING SCHEMATIC

A12135

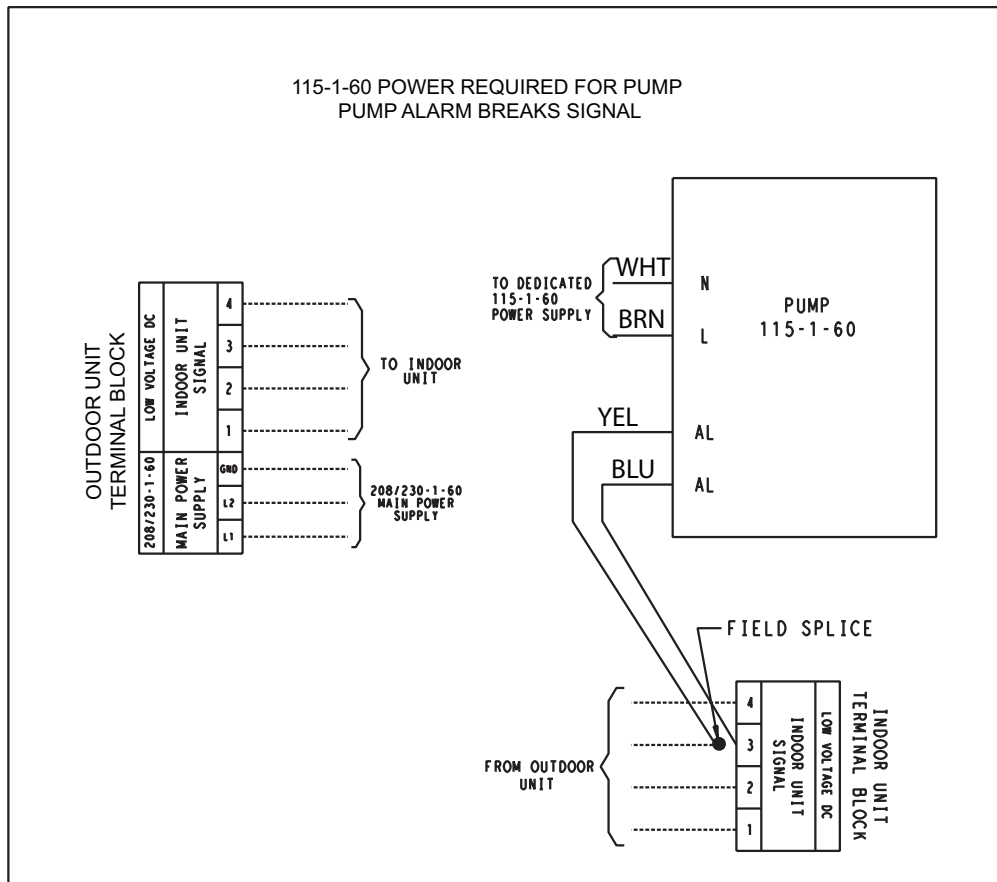
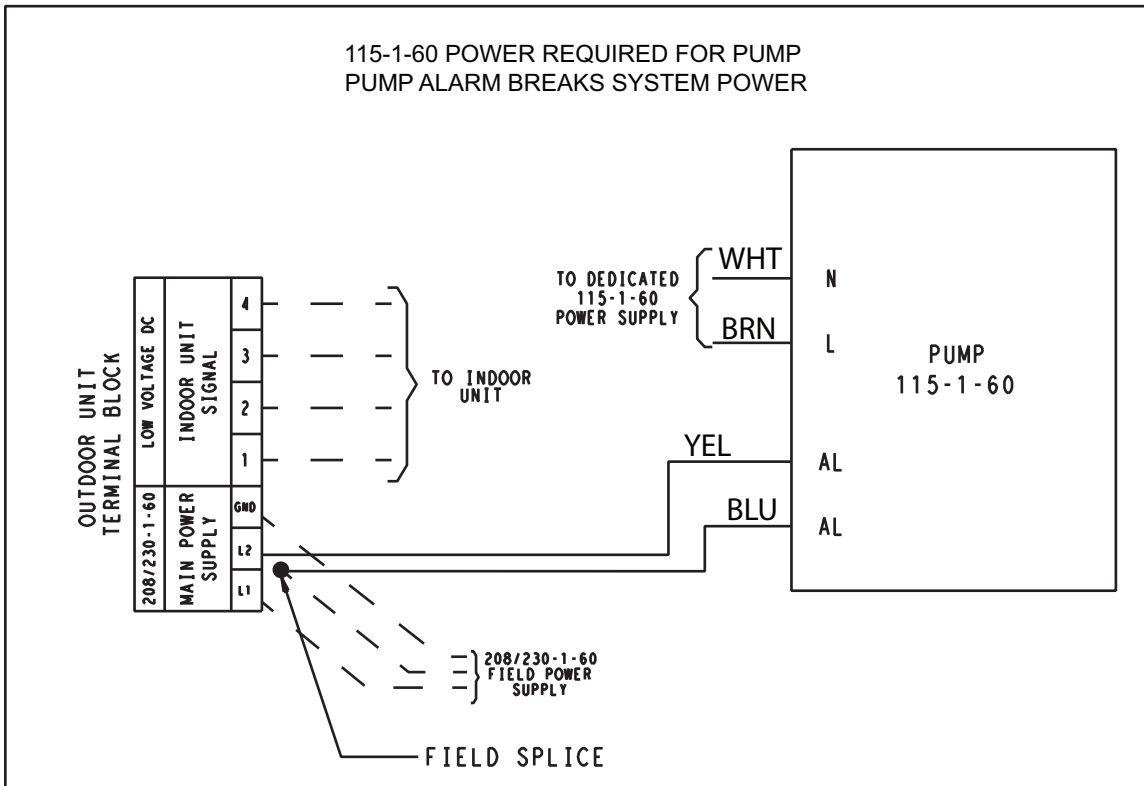

Fig. 9 – (208/230-1-60) WIRING SCHEMATIC

A12136



**Fig. 10 – (115-1-60) WIRING SCHEMATIC**

A12137

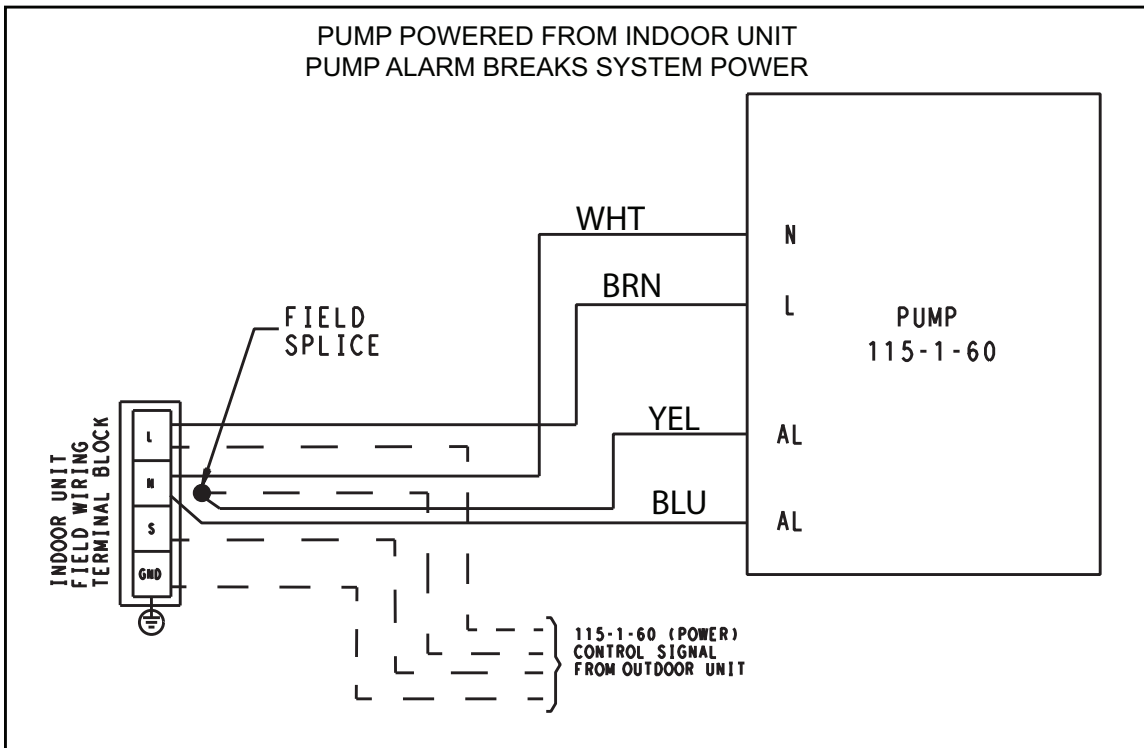

**Fig. 11 – (115-1-60) WIRING SCHEMATIC**

A12138

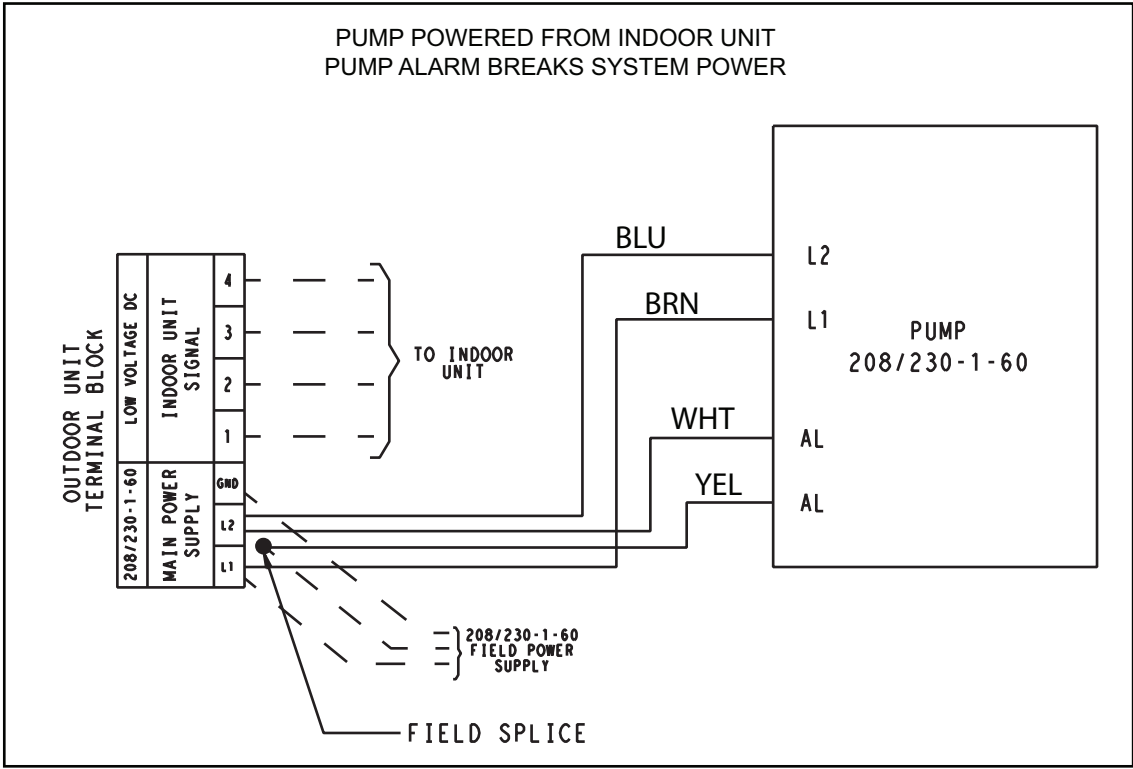

Fig. 12 - (208/230-1-60) WIRING SCHEMATIC

A12139

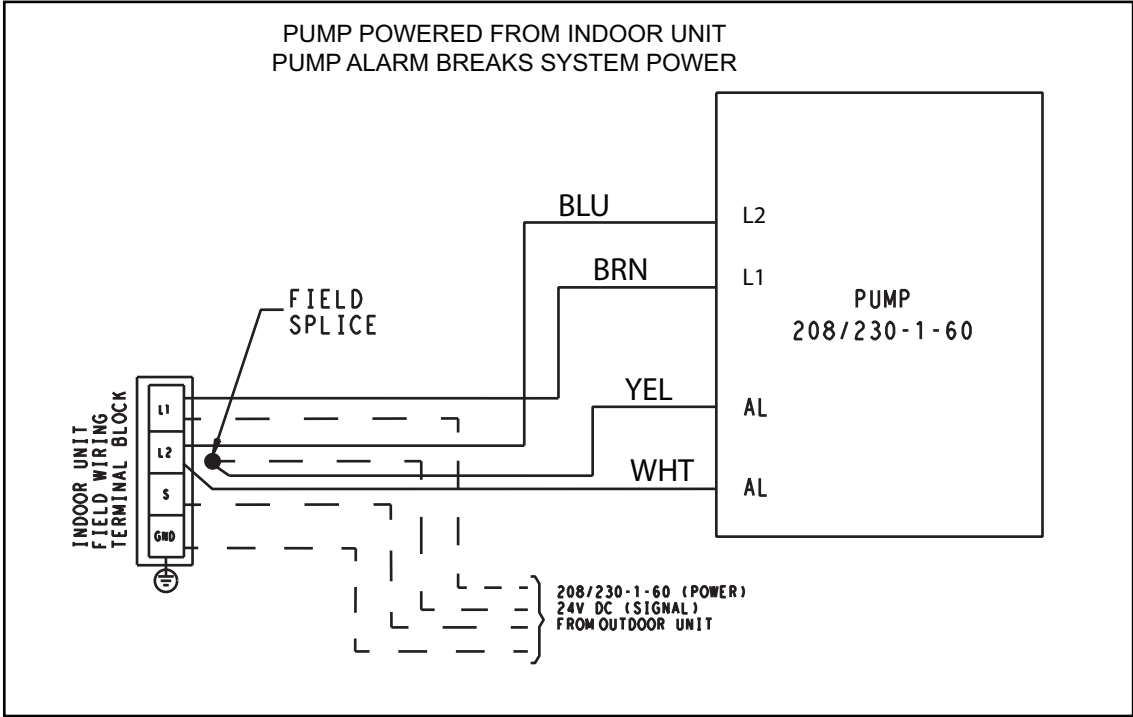
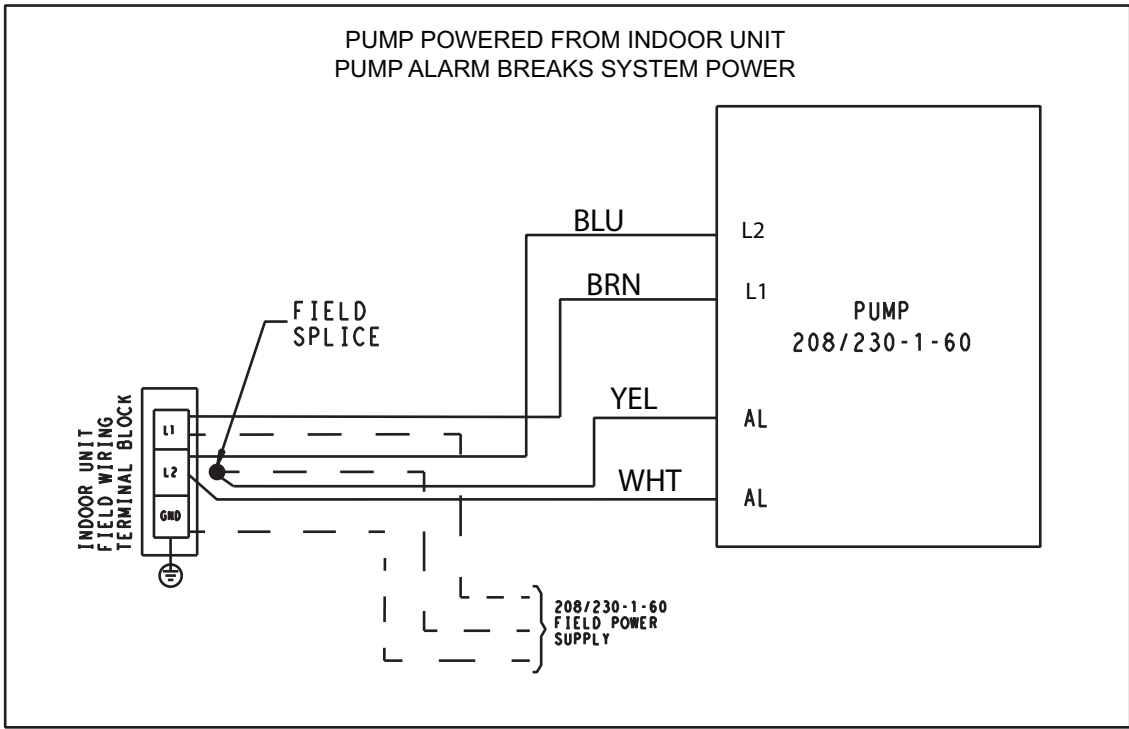

Fig. 13 - (208/230-1-60) WIRING SCHEMATIC

A12140



**Fig. 14 – (208/230-1-60) WIRING SCHEMATIC**

A12141

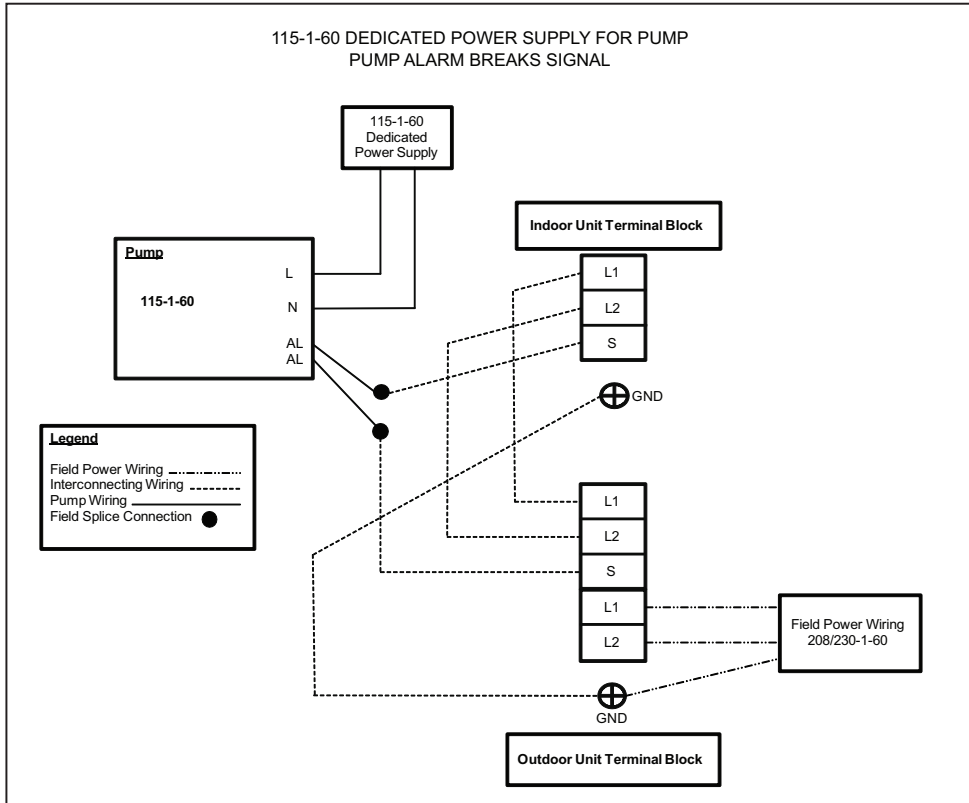

**Fig. 15 – (115-1-60) WIRING SCHEMATIC**

A12142



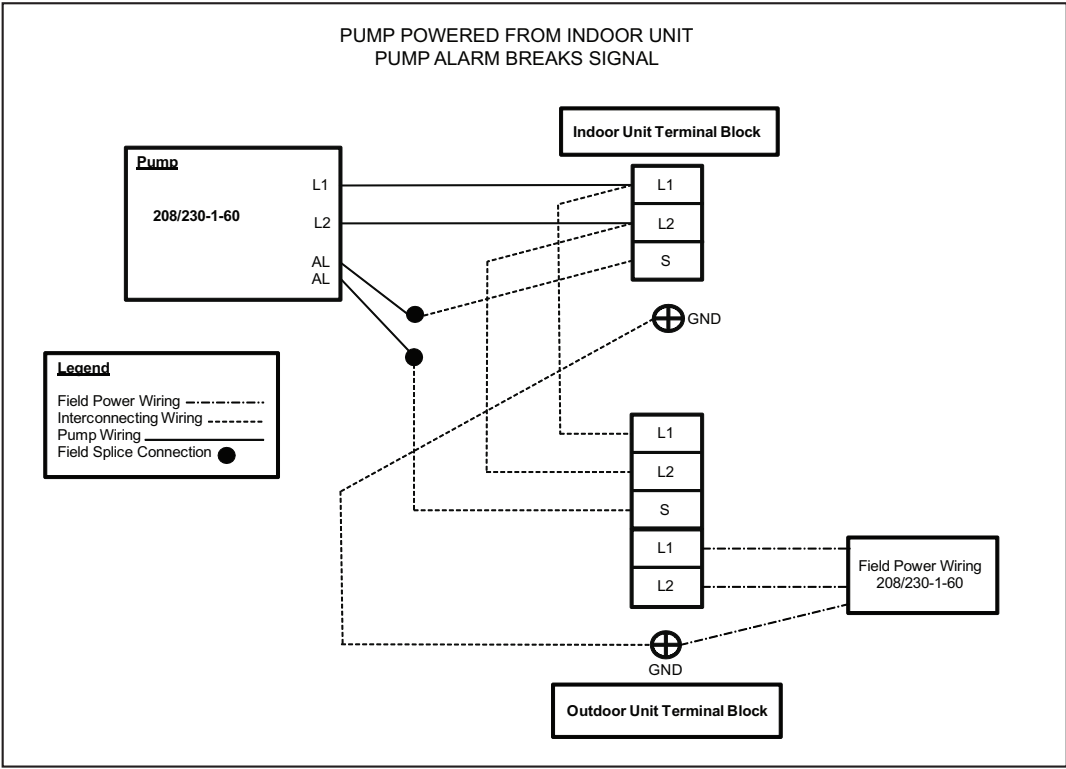

Fig. 16 – (208/230-1-60) WIRING SCHEMATIC

A12143

## CLEANING AND MAINTENANCE



### WARNING

#### ELECTRICAL SHOCK HAZARD

Failure to follow this warning could result in personal injury or death.

Disconnect all power to unit to avoid possible electrical shock during cleaning or maintenance. Set unit power switch to OFF position.

At the beginning of each season clean the detection unit.

1. Disconnect tubing and low voltage power cord from the detection unit and slide unit out of mounting bracket
2. Remove the top of the detection unit and take out the float.
3. Clean the detection unit and the float using a solution of water containing 5% bleach.
4. Replace the float in its original position with the magnet side facing up.
5. Snap cover back into place.
6. Perform an operational test (see item 13 under installation section).