

24AHA4
Performance™ Series Air Conditioner
with Puron® Refrigerant
1—1/2 to 5 Nominal Tons



Product Data



Performance
SERIES

Carrier air conditioners with Puron® refrigerant provide a collection of features unmatched by any other family of equipment. The 24AHA4 has been designed utilizing Carrier's Puron refrigerant. This environmentally sound refrigerant allows you to make a responsible decision in the protection of the earth's ozone layer.

NOTE: Ratings contained in this document are subject to change at any time. Always refer to the AHRI directory (www.ahridirectory.org) for the most up-to-date ratings information.

INDUSTRY LEADING FEATURES / BENEFITS

Energy Efficiency

- 14 SEER/11.7 – 12.2 EER
(Based on tested combinations)

Sound

- Levels as low as 66 dBA

Design Features

- Small footprint
- WeatherArmor™ cabinet
 - All steel cabinet construction
 - Mesh coil guard

Reliability, Quality and Toughness

- Scroll compressor
- Factory-supplied filter drier
- High pressure switch
- Line lengths up to 250' (76.2 m)
- Low ambient operation
(down to -20°F/-28.9°C with low ambient accessories)

MODEL NUMBER NOMENCLATURE

1	2	3	4	5	6	7	8	9	10	11	12	13
N	N	A	A	A/N	N	N	N	A/N	A/N	A/N	N	N
2	4	A	H	A	4	1	8	A	0	0	3	0
Product Series	Product Family	Product Type	Major Series	SEER	Cooling Capacity			Variations	Open	Open	Voltage	Minor Series
24=AC	A = AC	H = Horizontal Discharge		4 = 14 SEER				A= Standard	0= Not Defined	0= Not Defined	3=208/230-1 5=208/230-3 6=460/3	0, 1, 2...



Use of the AHRI Certified TM Mark indicates a manufacturer's participation in the program. For verification of certification for individual products, go to www.ahridirectory.org.



PHYSICAL DATA

UNIT SIZE – SERIES	18–30	24–30	30–30	36–30,50,60	48–30,50,60	60–30,50,60
COMPRESSOR TYPE	Scroll					
REFRIGERANT	Puron® (R-410A)					
Charge lb (kg)	6.40 (2.90)	6.50 (2.95)	8.60 (3.90)	8.90 (4.04)	9.00 (4.08)	10.60 (4.81)
COND FAN	Propeller Type, Direct Drive					
Air Discharge	Horizontal					
Air Qty (CFM)	1285	1285	1900	2615	2615	2785
Motor HP	1/12	1/12	1/10	1/4	1/4	1/4
Motor RPM	800	800	800	800	800	800
COND COIL						
Face Area (Sq ft)	7.3	7.3	12.1	12.1	12.1	14.1
Fins per In.	20	20	20	20	20	20
Rows	2	2	2	2	2	2
Circuits	3	3	3	3	3	4
VALVE CONNECT. (In. ID)						
Vapor	5/8	3/4	3/4	7/8	7/8	7/8
Liquid	3/8					
REFRIGERANT TUBES* (In. OD)						
Rated Vapor*	5/8	3/4	3/4	7/8	7/8	1 1/8
Max Liquid Line†	3/8					

* Units are rated with 25 ft (7.6 m) of lineset length. See Vapor Line Sizing and Cooling Capacity Loss table when using other sizes and lengths of lineset.
Note: See unit Installation Instruction for proper installation.

† See *Liquid Line Sizing For Cooling Only Systems with Puron Refrigerant* tables.

REFRIGERANT PIPING LENGTH LIMITATIONS

Liquid Line Sizing and Maximum Total Equivalent Lengths† for Cooling Only Systems with Puron® Refrigerant:

The maximum allowable length of a residential split system depends on the liquid line diameter and vertical separation between indoor and outdoor units.

See the table below for liquid line sizing and maximum lengths :

Maximum Total Equivalent Length Outdoor Unit BELOW Indoor Unit

Size	Liquid Line Connection	Liquid Line Diam. w/ TXV	AC with Puron Refrigerant Maximum Total Equivalent Length†: Outdoor unit BELOW Indoor Vertical Separation ft (m)								
			0-5 (0-1.5)	6-10 (1.8-3.0)	11-20 (3.4-6.1)	21-30 (6.4-9.1)	31-40 (9.4-12.2)	41-50 (12.5-15.2)	51-60 (15.5-18.3)	61-70 (18.6-21.3)	71-80 (21.6-24.4)
018 AC with Puron	3/8	1/4	150	150	125	100	100	75	---	---	---
		5/16	250*	250*	250*	250*	250*	250*	250*	225*	150
		3/8	250*	250*	250*	250*	250*	250*	250*	250*	250*
024 AC with Puron	3/8	1/4	75	75	75	50	50	---	---	---	---
		5/16	250*	250*	250*	250*	250*	225*	175	125	100
		3/8	250*	250*	250*	250*	250*	250*	250*	250*	250*
030 AC with Puron	3/8	1/4	30	---	---	---	---	---	---	---	---
		5/16	175	225*	200	175	125	100	75	---	---
		3/8	250*	250*	250*	250*	250*	250*	250*	250*	250*
036 AC with Puron	3/8	5/16	175	150	150	100	100	100	75	---	---
		3/8	250*	250*	250*	250*	250*	250*	250*	250*	250*
048 AC with Puron	3/8	3/8	250*	250*	250*	250*	250*	250*	230	160	---
060 AC with Puron	3/8	3/8	250*	250*	250*	225*	190	150	110	---	---

* Maximum actual length not to exceed 200 ft (61 m)

† Total equivalent length accounts for losses due to elbows or fitting. See the Long Line Guideline for details.

--- = outside acceptable range

Maximum Total Equivalent Length Outdoor Unit ABOVE Indoor Unit

Size	Liquid Line Connection	Liquid Line Diam. w/ TXV	AC with Puron Refrigerant Maximum Total Equivalent Length†: Outdoor unit ABOVE Indoor Vertical Separation ft (m)								
			25 (7.6)	26-50 (7.9-15.2)	51-75 (15.5-22.9)	76-100 (23.2-30.5)	101-125 (30.8-38.1)	126-150 (38.4-45.7)	151-175 (46.0-53.3)	176-200 (53.6-61.0)	
018 AC with Puron	3/8	1/4	175	250*	250*	250*	250*	250*	250*	250*	250*
		5/16	250*	250*	250*	250*	250*	250*	250*	250*	250*
		3/8	250*	250*	250*	250*	250*	250*	250*	250*	250*
024 AC with Puron	3/8	1/4	100	125	175	200	225*	250*	250*	250*	250*
		5/16	250*	250*	250*	250*	250*	250*	250*	250*	250*
		3/8	250*	250*	250*	250*	250*	250*	250*	250*	250*
030 AC with Puron	3/8	1/4	30	---	---	---	---	---	---	---	---
		5/16	250*	250*	250*	250*	250*	250*	250*	250*	250*
		3/8	250*	250*	250*	250*	250*	250*	250*	250*	250*
036 AC with Puron	3/8	5/16	225*	250*	250*	250*	250*	250*	250*	250*	250*
		3/8	250*	250*	250*	250*	250*	250*	250*	250*	250*
048 AC with Puron	3/8	3/8	250*	250*	250*	250*	250*	250*	250*	250*	250*
060 AC with Puron	3/8	3/8	250*	250*	250*	250*	250*	250*	250*	250*	250*

* Maximum actual length not to exceed 200 ft (61 m)

† Total equivalent length accounts for losses due to elbows or fitting. See the Long Line Guideline for details.

--- = outside acceptable range

REFRIGERANT CHARGE ADJUSTMENTS

Liquid Line Size	Puron Charge oz/ft (g/m)
3/8	0.60 (17.74) (Factory charge for lineset = 9 oz / 266.16 g)
5/16	0.40 (11.83)
1/4	0.27 (7.98)

Units are factory charged for 15 ft (4.6 m) of 3/8" liquid line. The factory charge for 3/8" lineset 9 oz (266.16 g). When using other length or diameter liquid lines, charge adjustments are required per the chart above.

Charging Formula:

$[(\text{Lineset oz/ft} \times \text{total length}) - (\text{factory charge for lineset})] = \text{charge adjustment}$

Example 1: System has 15 ft of line set using existing 1/4" liquid line. What charge adjustment is required?

Formula: $(.27 \text{ oz/ft} \times 15\text{ft}) - (9 \text{ oz}) = (-4.95) \text{ oz.}$

Net result is to remove 4.95 oz of refrigerant from the system

Example 2: System has 45 ft of existing 5/16" liquid line. What is the charge adjustment?

Formula: $(.40 \text{ oz/ft.} \times 45\text{ft}) - (9 \text{ oz.}) = 9 \text{ oz.}$

Net result is to add 9 oz of refrigerant to the system

LONG LINE APPLICATIONS

An application is considered Long Line, when the refrigerant level in the system requires the use of accessories to maintain acceptable refrigerant management for systems reliability. See Accessory Usage Guideline table for required accessories. Defining a system as long line depends on the liquid line diameter, actual length of the tubing, and vertical separation between the indoor and outdoor units.

For Air Conditioner systems, the chart below shows when an application is considered Long Line.

AC WITH PURON® REFRIGERANT LONG LINE DESCRIPTION ft (m) Beyond these lengths, long line accessories are required

Liquid Line Size	Units On Same Level	Outdoor Below Indoor	Outdoor Above Indoor
1/4	No accessories needed within allowed lengths	No accessories needed within allowed lengths	175 (53.3)
5/16	120 (36.6)	50 (15.2) vertical or 120 (36.6) total	120 (36.6)
3/8	80 (24.4)	35 (10.7) vertical or 80 (24.4) total	80 (24.4)

Note: See Long Line Guideline for details

VAPOR LINE SIZING AND COOLING CAPACITY LOSS

LONG LINE APPLICATION: An application is considered "Long line" when the total equivalent tubing length exceeds 80 ft. (24.38 m) or when there is more than 20 ft. (6.09 m) vertical separation between indoor and outdoor units. These applications require additional accessories and system modifications for reliable system operation. The maximum allowable total equivalent length is up to 250 ft. (76.2 m). The maximum

vertical separation is 200 ft. (60.96 m) when outdoor unit is above indoor unit, and up to 80 ft. (24.38 m) when the outdoor unit is below the indoor unit. Refer to Accessory Usage Guideline below for required accessories. See Longline Application Guideline for required piping and system modifications. Also, refer to the table below for the vapor tube diameters based on the total length to minimize the cooling capacity loss.

Vapor Line Sizing and Cooling Capacity Losses — Puron® Refrigerant 1-Stage Air Conditioner Applications

Unit Nominal Size (Btuh)	Maximum Liquid Line Diameters (In. OD)	Vapor Line Diameters (In. OD)	Cooling Capacity Loss (%)								
			Total Equivalent Line Length ft. (m)								
			26-50 (7.9-15.2)	51-80 (15.5-24.4)	81-100 (24.7-30.5)	101-125 (30.8-38.1)	126-150 (38.4-45.7)	151-175 (46.0-53.3)	176-200 (53.6-61.0)	201-225 (61.3-68.6)	226-250 (68.9-76.2)
018 1 Stage AC with Puron	3/8	1/2	1	2	3	5	6	7	8	9	11
		5/8	0	1	1	1	2	2	2	3	3
		3/4	0	0	0	0	1	1	1	1	1
024 1 Stage AC with Puron	3/8	5/8	0	1	2	2	3	3	4	5	5
		3/4	0	0	1	1	1	1	1	2	2
		7/8	0	0	0	0	0	1	1	1	1
030 1 Stage AC with Puron	3/8	5/8	1	2	3	3	4	5	6	7	8
		3/4	0	0	1	1	1	2	2	2	3
		7/8	0	0	0	0	1	1	1	1	1
036 1 Stage AC with Puron	3/8	5/8	1	2	4	5	6	8	9	10	12
		3/4	0	1	1	2	2	3	3	4	4
		7/8	0	0	0	1	1	1	1	2	2
048 1 Stage AC with Puron	3/8	3/4	0	1	2	3	4	5	5	6	7
		7/8	0	0	1	1	2	2	2	3	3
		1 1/8	0	0	0	0	0	0	0	1	1
060 1 Stage AC with Puron	3/8	3/4	1	2	4	5	6	7	9	10	11
		7/8	0	1	2	2	3	4	4	5	5
		1 1/8	0	0	0	1	1	1	1	1	1

Applications in this area may be long line and may have height restrictions. See the Residential Piping and Long Line Guideline.

ACCESSORIES

KIT NUMBER	KIT NAME	Unit Size (Voltage/Series)											
		018 (30)	024 (30)	030 (30)	036 (30)	036 (50)	036 (60)	048 (30)	048 (50)	048 (60)	060 (30)	060 (50)	060 (60)
KAACH1401AAA	Crankcase Heater	X	X	X	X	X							
KAACH1201AAA	Crankcase Heater							X	X		X	X	
KAACH1501AAA	Crankcase Heater						X						
KAACH1901AAA	Crankcase Heater									X			X
KSAFT0101AAA	Evaporator Freeze Stat	X	X	X	X	X	X	X	X	X	X	X	X
KAATD0101TDR	Time Delay Relay	X	X	X	X	X	X	X	X	X	X	X	X
KAAWS0101AAA	Winter Start Kit	X	X	X	X	X	X	X	X	X	X	X	X
KSALA0801AAA	MotorMaster® 230v	X	X	X	X	X		X	X		X	X	
KSALA0901AAA	MotorMaster® 460v						X			X			X
53DS-900-087	Wind Baffle	X	X										
53DS-900-071	Wind Baffle			X	X	X	X	X	X	X			
53DS-900-088	Wind Baffle										X	X	X
53DS-900-075	Stacking Kit	X	X										
53DS-900-076	Stacking Kit			X	X	X	X	X	X	X	X	X	X
53DS-900-077	Wall Mounting Kit	X	X										
53DS-900-078	Wall Mounting Kit			X	X	X	X	X	X	X	X	X	X
KAALP0401PUR	Low Pressure Switch Kit	X	X	X	X	X	X	X	X	X	X	X	X
KSASH2301COP	Sound Blanket Kit	X	X	X	X	X	X						
KSASH2401COP	Sound Blanket Kit							X	X	X	X	X	X
KAALS0201LLS	Solenoid Valve Kit	X	X	X	X	X	X	X	X	X	X	X	X
KSAS1501AAA	Capacitor Relay Start Assist	X	X	X	X			X			X		

X = Accessory

ACCESSORY THERMOSTATS

PART NUMBER	DESCRIPTION
TP-WEM01	Côr™ Thermostat
TP-PRH01-A	edge™ Programmable Relative Humidity Thermostat
TP-PAC01	edge™ Programmable Thermostat
TP-NRH01	edge™ Non-Programmable Relative Humidity Thermostat
TP-NAC01	edge™ Non-Programmable Thermostat
TC-WHS01	Wi-Fi® Thermostat
TC-PAC01	Programmable Thermostat
TC-NAC01	Non-Programmable Thermostat
TCSNAC01	Non-Programmable Standard Screen Thermostat

THERMOSTAT ACCESSORIES		
TP-EXP	edge™ EXP® Card	Programmable edge™ thermostats
TSTATCCSEN01-B	Outdoor Air Temperature Sensor	TP-Pxx, TP-Nxx
TSTATXXCNV10	Thermostat Conversion Kit (4 to 5 wire) - 10 pack	All Carrier® branded thermostats
TX-MBP01	Medium Decorative Backplate	TC-Nxx
TX-LBP01	Large Decorative Backplate	TP-Pxx, TP-Nxx, TC-Pxx

ACCESSORY USAGE GUIDELINES

Accessory	REQUIRED FOR LOW-AMBIENT COOLING APPLICATIONS (Below 55°F / 12.8°C)	REQUIRED FOR LONG LINE APPLICATIONS* (Over 80 ft. / 24.38 m)	REQUIRED FOR SEA COAST APPLICATIONS (Within 2 miles / 3.22 km)
Ball Bearing Fan Motor	Standard	Standard	Standard
Compressor Start Assist Capacitor and Relay	Yes	Yes	No
Crankcase Heater	Yes	Yes	No
Evaporator Freeze Thermostat	Yes	No	No
Liquid Line Solenoid Valve	No	See Long-Line Application Guideline	No
MotorMaster® Controller	Yes	No	No

* For tubing line sets between 80 and 200 ft. (24.38 and 60.96 m) and/or 20 ft. (6.09 m) vertical differential, refer to Residential Split-System Longline Application Guideline.

Accessory Description and Usage (Listed Alphabetically)

1. Ball-Bearing Fan Motor

A fan motor with ball bearings which permits speed reduction while maintaining bearing lubrication.

Usage Guideline:

Required on all units when using MotorMaster®

2. Compressor Start Assist – Capacitor and Relay

Start capacitor and relay gives a "hard" boost to compressor motor at each start up.

Usage Guideline:

Required for reciprocating compressors in the following applications:

Long line

Low ambient cooling

Hard shut off expansion valve on indoor coil

Liquid line solenoid on indoor coil

Required for single-phase scroll compressors in the following applications:

Long line

Low ambient cooling

Suggested for all compressors in areas with a history of low voltage problems.

3. Crankcase Heater

An electric resistance heater which mounts to the base of the compressor to keep the lubricant warm during off cycles. Improves compressor lubrication on restart and minimizes the chance of liquid slugging.

Usage Guideline:

Required in low ambient cooling applications.

Required in long line applications.

Suggested in all commercial applications.

4. Evaporator Freeze Thermostat

An SPST temperature-actuated switch that stops unit operation when evaporator reaches freeze-up conditions.

Usage Guideline:

Required when low ambient kit has been added.

5. Low Pressure Switch Kit

Optional added compressor protection against loss of refrigerant. It cuts out the system at 50 PSI and allows operation again at 95 PSI. Used for commercial or "harsh" environment applications for extra protection. Not required for Low-Ambient Cooling application.

6. MotorMaster Low-Ambient Controller

A fan-speed control device activated by a temperature sensor, designed to control condenser fan motor speed in response to the saturated condensing temperatures down to -20°F (-28.9°C), it maintains condensing temperature at 100°F +/- 10°F (37.8°C +/- 6°C).

Usage Guideline:

A MotorMaster Low-Ambient Controller must be used when the cooling operation is used at outdoor temperatures below 55°F (12.8°C).

Suggested for all commercial applications.

7. Winter Start Kit

The device is designed to alleviate nuisance opening of the low-pressure switch by bypassing it for the first 3 minutes of operation. A Winter Start control must be used where low evaporator temperatures, or nuisance tripping of low-pressure switch may be encountered. It is not required for low ambient cooling application unless a low-pressure switch KAALP0401PUR is added.

8. Time Delay Relay

Optional accessory for systems that do not have an integral blower time delay.

ELECTRICAL DATA

UNIT SIZE – voltage, series	V/PH	OPER VOLTS*		COMPR		FAN	MCA	MAX FUSE** or CKT BRK AMPS
		MAX	MIN	LRA	RLA	FLA		
18–30	208/230/1	253	197	56.3	9.0	0.50	11.8	20
24–30				62.9	10.9	0.50	14.1	25
30–30				73.0	14.1	0.70	18.3	30
36–30				77.0	14.1	1.20	18.8	30
48–30				124.0	18.5	1.20	24.3	40
60–30				152.5	23.7	1.45	31.1	50
36–50	208/230/3	253	197	71.0	9.0	1.20	12.5	20
48–50				83.1	13.7	1.20	18.3	30
60–50				110.0	15.9	1.45	21.4	35
36–60	460/3	506	414	38.0	5.6	0.60	7.6	15
48–60				41.0	6.2	0.70	8.5	15
60–60				52.0	7.1	0.80	9.7	15

LEGEND:

- FLA – Full Load Amps
 - HACR – Heating, Air Conditioning, Refrigeration
 - LRA – Locked Rotor Amps
 - NEC – National Electrical Code
 - RLA – Rated Load Amps (compressor)
- * Permissible limits of the voltage range at which the unit will operate satisfactorily
 ** Time-Delay fuse.
 Complies with 2007 requirements of ASHRAE Standards 90.1

A-WEIGHTED SOUND POWER (dBA)

Unit Size	Standard Rating (dBA)	Typical Octave Band Spectrum (dBA, without tone adjustment)						
		125	250	500	1000	2000	4000	8000
18	69	50.5	57.0	59.5	64.5	60.5	53.5	43.0
24	66	50.5	58.5	60.5	59.5	56.5	51.0	41.5
30	68	55.5	59.5	61.5	63.5	60.0	58.0	49.5
36	71	59.5	59.5	62.0	65.5	63.5	62.0	55.0
48	70	57.5	59.5	64.0	66.0	63.0	60.5	54.5
60	73	60.0	61.5	64.5	67.0	66.0	65.5	58.0

NOTE: Tested in accordance with AHRI Standard 270–08 (not listed in AHRI).

A-WEIGHTED SOUND POWER (dBA) WITH ACCESSORY SOUND SHEILD

Unit Size	Standard Rating (dBA)	Typical Octave Band Spectrum (dBA, without tone adjustment)						
		125	250	500	1000	2000	4000	8000
18	68	52.5	58.0	58.5	64.5	59.5	52.5	42.5
24	65	54.5	57.5	59.5	59.0	56.0	50.5	40.5
30	68	55.0	60.0	61.5	62.5	60.0	58.0	49.5
36	71	59.5	59.5	62.5	65.0	63.0	61.5	55.0
48	70	57.5	59.5	63.0	65.0	62.5	60.0	54.0
60	73	61.0	62.0	64.0	67.0	65.5	65.5	57.5

NOTES:

Tested in accordance with AHRI Standard 270–08 (not listed in AHRI).

CHARGING SUB-COOLING (TXV-TYPE EXPANSION DEVICE)

UNIT SIZE–SERIES	REQUIRED SUBCOOLING °F (°C)
18	12 (6.7)
24	12 (6.7)
30	12 (6.7)
36	8 (4.4)
48	12 (6.7)
60	10 (5.6)

DIMENSIONS – ENGLISH

UNIT	SERIES	ELECTRICAL CHARACTERISTICS				A	B	C	D	E	F	G	H	J	K	L	M	N	P	OPERATING WEIGHT (lbs)	SHIPPING WEIGHT (lbs)	SHIPPING DIMENSIONS (L x W x H)
24AHA418	0	X	0	0	0	31 1/8"	36 15/16"	14 9/16"	16"	23 7/16"	17 3/16"	23 1/8"	28 1/16"	13"	6 5/8"	11 1/4"	5/8"	2 7/8"	5 13/16"	146	166	42 15/16" X 18" X 34 1/8"
24AHA424	0	X	0	0	0	31 1/8"	36 15/16"	14 9/16"	16"	23 7/16"	17 3/16"	23 1/8"	28 1/16"	14"	6 3/4"	11 5/8"	3/4"	2 7/8"	5 13/16"	148	168	42 15/16" X 18" X 34 1/8"
24AHA430	0	X	0	0	0	37 1/8"	44 1/2"	17 1/16"	18 7/16"	30 1/2"	19 5/8"	29 1/8"	34 1/16"	13 11/16"	8 1/8"	15 7/8"	3/4"	3 3/8"	6 3/8"	183	213	50 1/2" X 20 1/2" X 40 1/8"
24AHA436	0	X	0	X	X	37 1/8"	44 1/2"	17 1/16"	18 7/16"	30 1/2"	19 5/8"	29 1/8"	34 1/16"	13 11/16"	8 1/8"	15 7/8"	7/8"	3 3/8"	6 3/8"	184	214	50 1/2" X 20 1/2" X 40 1/8"
24AHA448	0	X	0	X	X	37 1/8"	44 1/2"	17 1/16"	18 7/16"	30 1/2"	19 5/8"	29 1/8"	34 1/16"	14 1/2"	8 1/2"	18 7/8"	7/8"	3 3/8"	6 3/8"	213	243	50 1/2" X 20 1/2" X 40 1/8"
24AHA460	0	X	0	X	X	43 1/8"	44 1/2"	17 1/16"	18 7/16"	30 1/2"	19 5/8"	35 1/8"	40 1/16"	14 1/2"	8 1/2"	18 7/8"	7/8"	3 3/8"	6 3/8"	245	275	50 1/2" X 20 1/2" X 46 1/8"

208-230-160
230-160
208/230-3-60
460-3-60

X = YES
O = NO

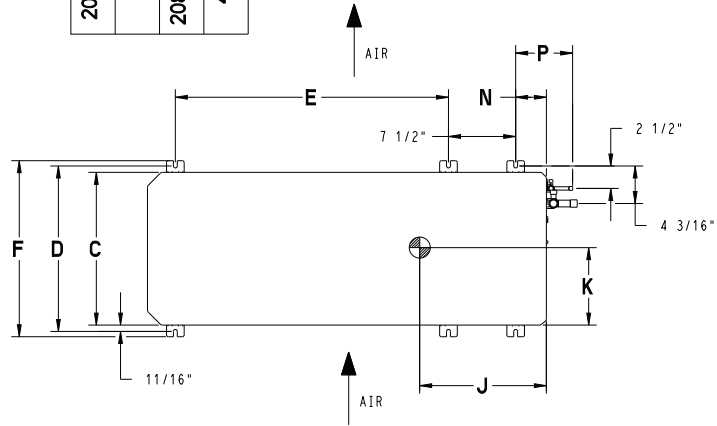

- CLEARANCE REQUIREMENTS: SINGLE UNIT APPLICATIONS: WITH COIL FACING WALL: ALLOW 6 IN. MINIMUM CLEARANCE ON COIL SIDE AND COIL END AND 20 IN. MINIMUM CLEARANCE ON FAN SIDE. WITH FAN FACING WALL: ALLOW 8 IN. MINIMUM CLEARANCE ON FAN SIDE AND 6 IN. ON COIL END AND 20 IN. MINIMUM CLEARANCE ON COIL SIDE. MULTI-UNIT APPLICATIONS: ALLOW 24 IN. MINIMUM CLEARANCE BETWEEN FAN AND COIL SIDES OF MULTIPLE UNITS. ARRANGE UNITS SO DISCHARGE OF ONE DOES NOT ENTER INLET OF ANOTHER. WHEN TWO UNITS ARE INSTALLED END TO END WITH THE COIL ENDS FACING EACH OTHER ALLOW 12 IN. MINIMUM CLEARANCE BETWEEN UNITS. COMPRESSOR END SERVICE CLEARANCE: ALLOW 24 IN. MINIMUM CLEARANCE ON COMPRESSOR END WHEN UNITS ARE STACKED OR THERE IS LESS THAN 40 IN. OF CLEARANCE ABOVE THE TOP OF THE UNIT. IF THERE IS 40 IN. CLEARANCE ABOVE UNIT AND THE TOP PANEL IS ACCESSIBLE FOR REMOVAL ALLOW 8 IN. MINIMUM CLEARANCE ON COMPRESSOR END FOR SERVICE.

IMPORTANT: WHEN INSTALLING SINGLE OR MULTIPLE UNITS IN AN ALCOVE, ROOF WELL, OR PARTIALLY ENCLOSED AREA, ENSURE THERE IS ADEQUATE VENTILATION TO PREVENT RECIRCULATION OF DISCHARGE AIR.

- MINIMUM OUTDOOR OPERATING AMBIENT IN COOLING MODE IS 55°F, MAX. 125°F.
- SERIES DESIGNATION IS THE 13TH POSITION OF THE UNIT MODEL NUMBER.
- CENTER OF GRAVITY
- ALL DIMENSIONS ARE IN "INCHES" UNLESS NOTED.

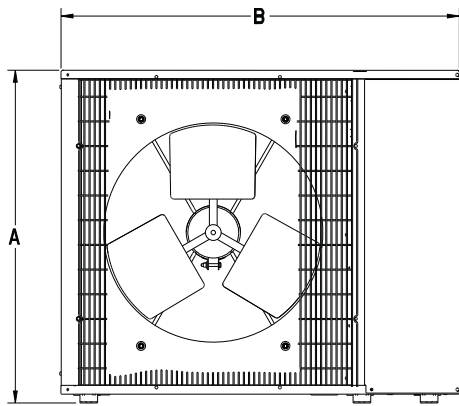

FIELD CONTROL SUPPLY WIRE ENTRY
7/8" HOLE W/GROMMET

M VAPOR LINE CONN.
FEMALE SWEAT CONN.

3/8" LIQUID LINE
FEMALE SWEAT CONN.

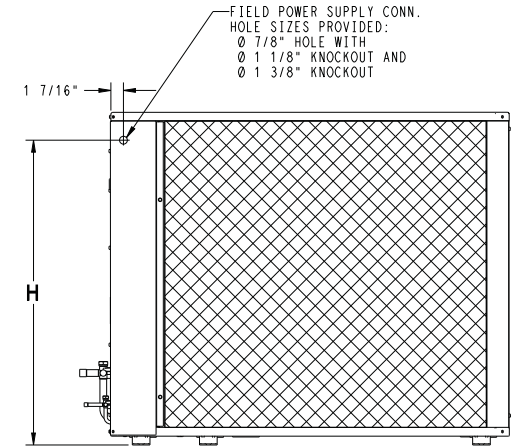
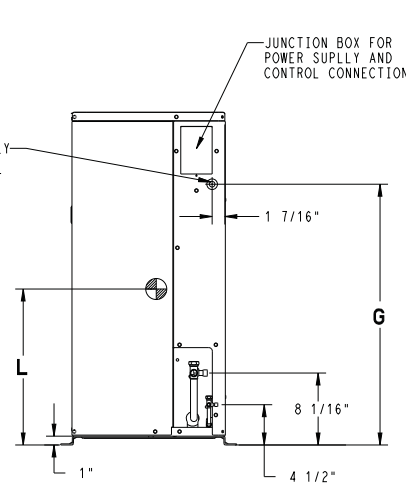

UNIT SIZE	MINIMUM MOUNTING PAD DIMENSIONS
18, 24	23" X 42"
30, 36, 48, 60	24" X 50"

DIMENSIONS – SI

UNIT	SERIES	ELECTRICAL CHARACTERISTICS				A	B	C	D	E	F	G	H	J	K	L	M	N	P	OPERATING WEIGHT(KG)	SHIPPING WEIGHT(KG)	SHIPPING DIMENSIONS (L x W x H)
24AHA418	0	X	0	0	0	790.4	938.0	370.0	406.0	595.5	436.0	587.6	712.2	330.2	168.3	285.8	15.9	73.0	148.2	66.2	75.3	1090.2 X 457.7 X 866.7
24AHA424	0	X	0	0	0	790.4	938.0	370.0	406.0	595.5	436.0	587.6	712.2	355.6	171.5	295.3	19.1	73.0	148.2	67.1	76.2	1090.2 X 457.7 X 866.7
24AHA430	0	X	0	0	0	942.8	1130.0	433.0	469.0	774.5	499.0	740.0	864.6	347.7	206.4	403.2	19.1	86.0	161.2	83.0	96.6	1282.7 X 520.7 X 1019.1
24AHA436	0	X	0	X	X	942.8	1130.0	433.0	469.0	774.5	499.0	740.0	864.6	347.7	206.4	403.2	22.2	86.0	161.2	83.5	97.1	1282.7 X 520.7 X 1019.1
24AHA448	0	X	0	X	X	942.8	1130.0	433.0	469.0	774.5	499.0	740.0	864.6	368.3	215.9	479.4	22.2	86.0	161.2	96.6	110.2	1282.7 X 520.7 X 1019.1
24AHA460	0	X	0	X	X	1095.2	1130.0	433.0	469.0	774.5	499.0	892.4	1017.0	368.3	215.9	479.4	22.2	86.0	161.2	111.1	124.7	1282.7 X 520.7 X 1171.5

208-230-160	230-160	208/230-3-60	460-3-60
-------------	---------	--------------	----------

X = YES
O = NO

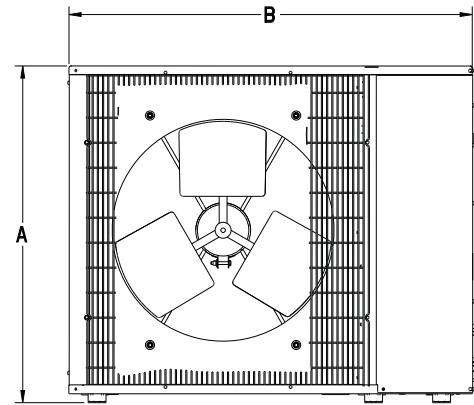
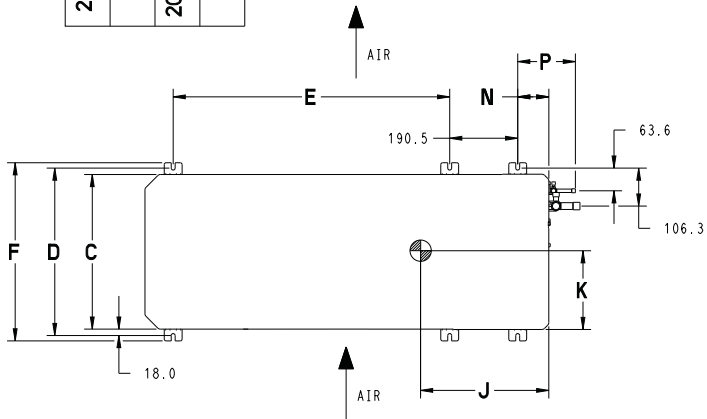

FIELD CONTROL SUPPLY WIRE ENTRY 22.22 HOLE W/GROMMET

Ø M VAPOR LINE CONN. FEMALE SWEAT CONN.

Ø 9.53 LIQUID LINE FEMALE SWEAT CONN.

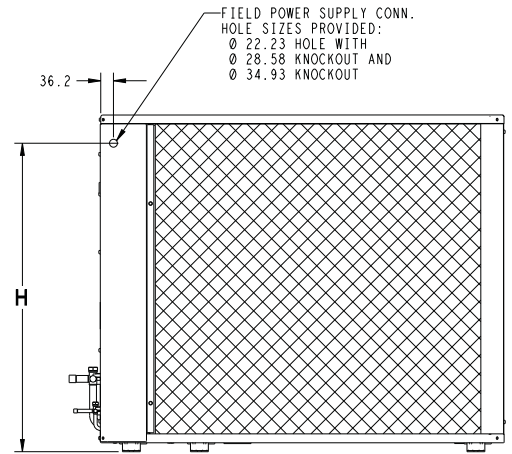
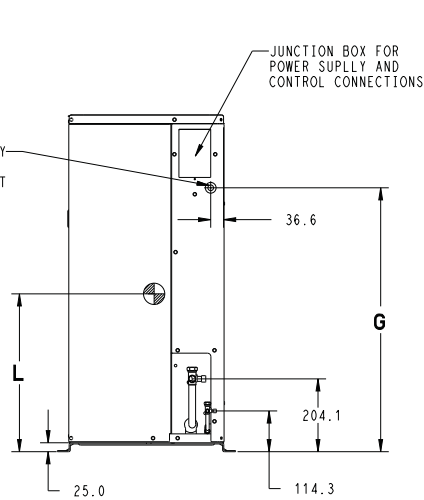

- CLEARANCE REQUIREMENTS: SINGLE UNIT APPLICATIONS: WITH COIL FACING WALL: ALLOW 152.4 mm MINIMUM CLEARANCE ON COIL SIDE AND COIL END AND 504 mm MINIMUM CLEARANCE ON FAN SIDE. WITH FAN FACING WALL: ALLOW 203.2 mm MINIMUM CLEARANCE ON FAN SIDE AND 152.4 mm ON COIL END AND 504.0 mm MINIMUM CLEARANCE ON COIL SIDE. MULTI-UNIT APPLICATIONS: ALLOW 609.6 mm MINIMUM CLEARANCE BETWEEN FAN AND COIL SIDES OF MULTIPLE UNITS. ARRANGE UNITS SO DISCHARGE OF ONE DOES NOT ENTER INLET OF ANOTHER. WHEN TWO UNITS ARE INSTALLED END TO END WITH THE COIL ENDS FACING EACH OTHER ALLOW 304.8 mm MINIMUM CLEARANCE BETWEEN UNITS. COMPRESSOR END SERVICE CLEARANCE: ALLOW 609.6 mm MINIMUM CLEARANCE ON COMPRESSOR END WHEN UNITS ARE STACKED OR THERE IS LESS THAN 1016 mm OF CLEARANCE ABOVE THE TOP OF THE UNIT. IF THERE IS 1016 mm CLEARANCE ABOVE UNIT AND THE TOP PANEL IS ACCESSIBLE FOR REMOVAL ALLOW 203.2 mm MINIMUM CLEARANCE ON COMPRESSOR END FOR SERVICE.

IMPORTANT: WHEN INSTALLING SINGLE OR MULTIPLE UNITS IN AN ALCOVE, ROOF WELL, OR PARTIALLY ENCLOSED AREA, ENSURE THERE IS ADEQUATE VENTILATION TO PREVENT RECIRCULATION OF DISCHARGE AIR.

- MINIMUM OUTDOOR OPERATING AMBIENT IN COOLING MODE IS 12.8°C, MAX. 51.7°C.
- SERIES DESIGNATION IS THE 14TH POSITION OF THE UNIT MODEL NUMBER.
- CENTER OF GRAVITY
- ALL DIMENSIONS ARE IN "MM" UNLESS NOTED.

UNIT SIZE	MINIMUM MOUNTING PAD DIMENSIONS
18, 24	584.2 X 1066.8
30, 36, 48, 60	609.6 X 1270.0

TESTED AHRI COMBINATION RATINGS*

NOTE: Ratings contained in this document are subject to change at any time.

For AHRI ratings certificates, please refer to the AHRI directory www.ahridirectory.org

Additional ratings and system combinations can be accessed via the Carrier database at: www.MyCarrierRatings.com

For performance data at specific application &/or design conditions with various indoor unit combinations, the equipment performance calculator can be accessed at : <http://rpmob.wrightsoft.com/>

Outdoor Model Number	Indoor Coil Model Number	Furnace Model Number	Capacity	EER	SEER
24AHA418A30	CNPV*3014AL*+TDR		18,000	12.2	14
24AHA424A30	CNPV*3117AL*+TDR		24,000	12.2	14
24AHA430A30	CNPV*3117AL*+TDR		29,600	12.2	14
24AHA436A30	CNPV*3717AL*+TDR		35,400	12.2	14
24AHA436A50	CNPV*3717AL*+TDR		35,400	12.2	14
24AHA436A60	CNPV*3717AL*+TDR		35,400	12.2	14
24AHA448A30	CNPV*6024AL*+TDR		45,000	11.7	14
24AHA448A50	CNPV*6024AL*+TDR		45,000	11.7	14
24AHA448A60	CNPV*6024AL*+TDR		45,000	11.7	14
24AHA460A30	CNPV*6124AL*+TDR		57,000	11.7	14
24AHA460A50	CNPV*6124AL*+TDR		57,000	11.7	14
24AHA460A60	CNPV*6124AL*+TDR		57,000	11.7	14

EER — Energy Efficiency Ratio

SEER — Seasonal Energy Efficiency Ratio

TXV — Thermostatic Expansion Valve

NOTES:

1. Ratings are net values reflecting the effects of circulating fan motor heat. Supplemental electric heat is not included.
2. Tested outdoor/indoor combinations have been tested in accordance with DOE test procedures for central air conditioners. Ratings for other combinations are determined under DOE computer simulation procedures.
3. Determine actual CFM values obtainable for your system by referring to fan performance data in fan coil or furnace coil literature.
4. Do not apply with capillary tube coils as performance and reliability are significantly affected.

DETAILED COOLING CAPACITIES

EVAPORATOR AIR		CONDENSER ENTERING AIR TEMPERATURES °F (°C)																	
CFM	EWB °F (°C)	75 (23.9)			85 (29.4)			95 (35)			105 (40.6)			115 (46.1)			125 (51.7)		
		Capacity MBtuh		Total Sys KW**	Capacity MBtuh		Total Sys KW**	Capacity MBtuh		Total Sys KW**	Capacity MBtuh		Total Sys KW**	Capacity MBtuh		Total Sys KW**	Capacity MBtuh		Total Sys KW**
		Total	Sens†		Total	Sens†		Total	Sens†		Total	Sens†		Total	Sens†		Total	Sens†	
24AHA418A30 Outdoor Section With CNPV*3014AL* Indoor Section																			
525	72 (22.2)	21.49	10.92	1.18	20.55	10.57	1.31	19.56	10.21	1.45	18.50	9.83	1.61	17.36	9.43	1.79	16.12	9.00	2.00
	67 (19.4)	19.43	13.31	1.18	18.58	12.96	1.31	17.67	12.60	1.45	16.71	12.22	1.61	15.68	11.82	1.79	14.57	11.39	2.00
	63 (17.2)	17.96	12.78	1.18	17.15	12.43	1.31	16.31	12.06	1.45	15.43	11.69	1.61	14.48	11.29	1.79	13.46	10.86	2.00
	62 (16.7)	17.68	15.68	1.18	16.91	15.33	1.31	16.11	14.96	1.45	15.28	14.56	1.61	14.48	14.48	1.79	13.65	13.65	2.00
600	72 (22.2)	21.93	11.50	1.21	20.94	11.14	1.34	19.90	10.77	1.48	18.79	10.38	1.64	17.61	9.97	1.82	16.32	9.53	2.03
	67 (19.4)	19.84	14.22	1.21	18.94	13.87	1.34	18.00	13.50	1.48	17.00	13.11	1.63	15.93	12.70	1.82	14.78	12.26	2.03
	63 (17.2)	18.34	13.63	1.21	17.51	13.27	1.33	16.63	12.90	1.47	15.70	12.51	1.63	14.72	12.10	1.82	13.65	11.66	2.03
	62 (16.7)	18.14	16.91	1.21	17.36	16.53	1.33	16.61	16.61	1.47	15.86	15.86	1.63	15.05	15.05	1.82	14.15	14.15	2.03
	57 (13.9)	17.95	17.95	1.21	17.29	17.29	1.33	16.59	16.59	1.47	15.84	15.84	1.63	15.02	15.02	1.82	14.13	14.13	2.03
675	72 (22.2)	22.25	12.05	1.24	21.22	11.69	1.36	20.15	11.31	1.50	19.00	10.91	1.66	17.78	10.50	1.85	16.46	10.05	2.06
	67 (19.4)	20.15	15.11	1.24	19.22	14.74	1.36	18.25	14.37	1.50	17.22	13.97	1.66	16.12	13.55	1.85	14.94	13.09	2.06
	63 (17.2)	18.64	14.45	1.24	17.77	14.08	1.36	16.86	13.70	1.50	15.91	13.30	1.66	14.90	12.88	1.84	13.81	12.42	2.06
	62 (16.7)	18.63	18.63	1.24	17.92	17.92	1.36	17.18	17.18	1.50	16.38	16.38	1.66	15.51	15.51	1.84	14.56	14.56	2.06
57 (13.9)	18.60	18.60	1.24	17.89	17.89	1.36	17.15	17.15	1.50	16.36	16.36	1.66	15.49	15.49	1.84	14.55	14.55	2.06	

EVAPORATOR AIR		CONDENSER ENTERING AIR TEMPERATURES °F (°C)																	
CFM	EWB °F (°C)	75 (23.9)			85 (29.4)			95 (35)			105 (40.6)			115 (46.1)			125 (51.7)		
		Capacity MBtuh		Total Sys KW**	Capacity MBtuh		Total Sys KW**	Capacity MBtuh		Total Sys KW**	Capacity MBtuh		Total Sys KW**	Capacity MBtuh		Total Sys KW**	Capacity MBtuh		Total Sys KW**
		Total	Sens†		Total	Sens†		Total	Sens†		Total	Sens†		Total	Sens†		Total	Sens†	
24AHA424A30 Outdoor Section With CNPV*3117AL* Indoor Section																			
700	72 (22.2)	28.62	14.23	1.58	27.33	13.77	1.75	25.95	13.30	1.94	24.48	12.80	2.15	22.90	12.26	2.40	21.21	11.70	2.67
	67 (19.4)	26.06	17.53	1.57	24.88	17.08	1.74	23.63	16.60	1.93	22.30	16.09	2.14	20.87	15.56	2.39	19.33	14.99	2.67
	63 (17.2)	24.20	16.87	1.57	23.11	16.41	1.74	21.96	15.94	1.92	20.73	15.44	2.14	19.41	14.91	2.38	17.99	14.34	2.66
	62 (16.7)	23.80	20.79	1.57	22.74	20.32	1.73	21.65	19.83	1.92	20.58	20.58	2.14	19.51	19.51	2.38	18.33	18.33	2.66
800	72 (22.2)	29.11	14.99	1.62	27.76	14.53	1.79	26.33	14.04	1.98	24.80	13.53	2.19	23.16	12.99	2.43	21.41	12.42	2.71
	67 (19.4)	26.53	18.75	1.61	25.30	18.29	1.78	24.00	17.80	1.97	22.61	17.28	2.18	21.13	16.74	2.43	19.54	16.16	2.70
	63 (17.2)	24.68	18.01	1.61	23.53	17.54	1.77	22.33	17.06	1.96	21.05	16.55	2.18	19.67	16.00	2.42	18.21	15.42	2.70
	62 (16.7)	24.39	22.42	1.61	23.40	23.40	1.77	22.42	22.42	1.96	21.36	21.36	2.18	20.20	20.20	2.42	18.94	18.94	2.70
	57 (13.9)	24.28	24.28	1.61	23.36	23.36	1.77	22.39	22.39	1.96	21.32	21.32	2.18	20.17	20.17	2.42	18.91	18.91	2.70
900	72 (22.2)	29.46	15.72	1.66	28.07	15.25	1.83	26.59	14.76	2.01	25.01	14.24	2.23	23.33	13.69	2.47	21.53	13.11	2.75
	67 (19.4)	26.88	19.93	1.65	25.61	19.46	1.82	24.27	18.96	2.01	22.84	18.43	2.22	21.32	17.87	2.46	19.70	17.27	2.74
	63 (17.2)	25.04	19.11	1.65	23.85	18.63	1.81	22.60	18.14	2.00	21.28	17.61	2.21	19.87	17.05	2.46	18.38	16.43	2.74
	62 (16.7)	25.15	25.15	1.65	24.16	24.16	1.81	23.11	23.11	2.00	21.98	21.98	2.22	20.75	20.75	2.46	19.42	19.42	2.74
57 (13.9)	25.11	25.11	1.65	24.13	24.13	1.81	23.08	23.08	2.00	21.95	21.95	2.22	20.73	20.73	2.46	19.39	19.39	2.74	

See notes on pg. 13

DETAILED COOLING CAPACITIES(CONT.)

Evaporator Air		CONDENSER ENTERING AIR TEMPERATURES °F (°C)																							
CFM	EWB °F (°C)	75 (23.9)				85 (29.4)				95 (35)				105 (40.6)				115 (46.1)				125 (51.7)			
		Capacity MBtu/h		Total System KW**	Total System KW**	Capacity MBtu/h		Total System KW**	Total System KW**	Capacity MBtu/h		Total System KW**	Total System KW**	Capacity MBtu/h		Total System KW**	Total System KW**	Capacity MBtu/h		Total System KW**	Total System KW**				
		Total	Sens†	Total		Sens†	Total	Sens†		Total	Sens†	Total		Sens†	Total	Sens†		Total	Sens†						
24AHA430A30 Outdoor Section With CNPV*3117AL* Indoor Section																									
875	72 (22.2)	35.20	16.84	1.95	33.62	16.29	2.18	31.97	15.73	2.43	30.18	15.13	2.70	28.24	14.48	3.02	26.13	13.79	3.38						
	67 (19.4)	31.99	20.62	1.92	30.56	20.08	2.15	29.06	19.51	2.40	27.44	18.91	2.68	25.67	18.26	3.00	23.75	17.57	3.36						
	63 (17.2)	29.66	19.84	1.90	28.34	19.30	2.13	26.95	18.74	2.37	25.45	18.13	2.66	23.80	17.48	2.98	22.02	16.78	3.35						
	62 (16.7)	29.18	24.36	1.90	27.92	23.82	2.12	26.58	23.24	2.37	25.18	24.97	2.65	23.81	23.81	2.98	22.34	22.34	3.35						
1000	57 (13.9)	28.38	28.38	1.89	27.37	27.37	2.12	26.28	26.28	2.37	25.09	25.09	2.65	23.77	23.77	2.98	22.31	22.31	3.35						
	72 (22.2)	35.90	17.73	1.98	34.26	17.17	2.21	32.52	16.59	2.46	30.66	15.98	2.74	28.65	15.32	3.05	26.46	14.62	3.41						
	67 (19.4)	32.65	22.03	1.95	31.17	21.48	2.18	29.60	20.90	2.43	27.91	20.28	2.71	26.08	19.62	3.03	24.10	18.91	3.39						
	63 (17.2)	30.30	21.15	1.93	28.93	20.60	2.16	27.48	20.02	2.40	25.91	19.41	2.69	24.21	18.74	3.01	22.36	18.02	3.37						
1125	62 (16.7)	29.94	26.26	1.93	28.66	25.66	2.15	27.43	27.43	2.41	26.15	26.15	2.69	24.73	24.73	3.01	23.17	23.17	3.38						
	57 (13.9)	29.65	29.65	1.93	28.56	28.56	2.15	27.39	27.39	2.40	26.11	26.11	2.69	24.70	24.70	3.01	23.14	23.14	3.38						
	72 (22.2)	36.44	18.57	2.01	34.73	18.00	2.24	32.94	17.41	2.49	31.02	16.79	2.77	28.94	16.12	3.08	26.71	15.41	3.43						
	67 (19.4)	33.18	23.38	1.98	31.64	22.82	2.21	30.01	22.23	2.46	28.28	21.60	2.74	26.40	20.92	3.05	24.38	20.18	3.41						
	63 (17.2)	30.81	22.41	1.96	29.38	21.85	2.19	27.89	21.26	2.43	26.28	20.63	2.72	24.53	19.94	3.04	22.65	19.20	3.40						
62 (16.7)	30.76	30.76	1.96	29.59	29.59	2.19	28.34	28.34	2.44	26.99	26.99	2.72	25.49	25.49	3.05	23.84	23.84	3.41							
57 (13.9)	30.72	30.72	1.96	29.55	29.55	2.19	28.31	28.31	2.44	26.95	26.95	2.72	25.45	25.45	3.04	23.81	23.81	3.41							

EVAPORATOR AIR		CONDENSER ENTERING AIR TEMPERATURES °F (°C)																							
CFM	EWB °F (°C)	75 (23.9)				85 (29.4)				95 (35)				105 (40.6)				115 (46.1)				125 (51.7)			
		Capacity MBtu/h		Total Sys KW**	Total Sys KW**	Capacity MBtu/h		Total Sys KW**	Total Sys KW**	Capacity MBtu/h		Total Sys KW**	Total Sys KW**	Capacity MBtu/h		Total Sys KW**	Total Sys KW**	Capacity MBtu/h		Total Sys KW**	Total Sys KW**				
		Total	Sens†	Total		Sens†	Total	Sens†		Total	Sens†	Total		Sens†	Total	Sens†		Total	Sens†						
24AHA436A30 Outdoor Section With CNPV*3717AL* Indoor Section																									
1050	72 (22.2)	42.58	22.26	2.36	40.51	21.51	2.60	38.30	20.71	2.87	35.94	19.87	3.16	33.37	18.97	3.50	30.62	18.01	3.88						
	67 (19.4)	38.73	27.46	2.34	36.87	26.71	2.58	34.88	25.92	2.84	32.74	25.08	3.14	30.43	24.18	3.48	27.97	23.23	3.86						
	63 (17.2)	35.96	26.41	2.32	34.24	25.67	2.56	32.40	24.88	2.82	30.43	24.04	3.12	28.31	23.15	3.46	26.03	22.20	3.85						
	62 (16.7)	35.38	32.60	2.32	33.73	31.84	2.56	32.01	31.81	2.82	30.38	30.38	3.12	28.63	28.63	3.46	26.73	26.73	3.85						
1200	57 (13.9)	34.71	34.71	2.31	33.37	33.37	2.55	31.92	31.92	2.82	30.34	30.34	3.12	28.59	28.59	3.46	26.70	26.70	3.85						
	72 (22.2)	43.29	23.46	2.42	41.13	22.69	2.66	38.84	21.88	2.93	36.37	21.02	3.22	33.71	20.10	3.56	30.85	19.13	3.94						
	67 (19.4)	39.43	29.38	2.40	37.47	28.61	2.64	35.40	27.80	2.90	33.18	26.94	3.20	30.79	26.02	3.53	28.26	25.05	3.92						
	63 (17.2)	36.64	28.20	2.38	34.83	27.43	2.62	32.92	26.62	2.88	30.87	25.77	3.18	28.67	24.85	3.52	26.33	23.88	3.91						
	62 (16.7)	36.27	36.05	2.38	34.77	34.77	2.62	33.20	33.20	2.89	31.50	31.50	3.19	29.61	29.61	3.53	27.57	27.57	3.92						
1350	57 (13.9)	36.17	36.17	2.38	34.71	34.71	2.62	33.15	33.15	2.89	31.45	31.45	3.19	29.57	29.57	3.53	27.54	27.54	3.91						
	72 (22.2)	43.81	24.60	2.48	41.58	23.82	2.72	39.20	23.00	2.99	36.66	22.13	3.28	33.92	21.20	3.62	31.04	20.23	4.00						
	67 (19.4)	39.93	31.22	2.46	37.92	30.44	2.70	35.78	29.61	2.96	33.50	28.73	3.26	31.06	27.78	3.59	28.49	26.76	3.98						
	63 (17.2)	37.14	29.91	2.44	35.28	29.13	2.68	33.30	28.30	2.94	31.20	27.42	3.24	28.94	26.47	3.58	26.58	25.43	3.97						
	62 (16.7)	37.43	37.43	2.44	35.87	35.87	2.68	34.21	34.21	2.95	32.39	32.39	3.25	30.39	30.39	3.59	28.23	28.23	3.98						
57 (13.9)	37.38	37.38	2.44	35.83	35.83	2.68	34.16	34.16	2.95	32.35	32.35	3.25	30.36	30.36	3.59	28.20	28.20	3.98							

See notes on pg. 13

DETAILED COOLING CAPACITIES (CONT.)

EVAPORATOR AIR		CONDENSER ENTERING AIR TEMPERATURES °F (°C)																	
CFM	EWB °F (°C)	75 (23.9)			85 (29.4)			95 (35)			105 (40.6)			115 (46.1)			125 (51.7)		
		Capacity MBtuh		Total Sys KW**	Capacity MBtuh		Total Sys KW**	Capacity MBtuh		Total Sys KW**	Capacity MBtuh		Total Sys KW**	Capacity MBtuh		Total Sys KW**	Capacity MBtuh		Total Sys KW**
		Total	Sens†		Total	Sens†		Total	Sens†		Total	Sens†		Total	Sens†		Total	Sens†	
24AHA448A30 Outdoor Section With CNPV*6024AL* Indoor Section																			
1400	72 (22.2)	54.32	28.47	3.22	51.89	27.57	3.53	49.29	26.62	3.88	46.43	25.59	4.29	43.30	24.47	4.76	39.89	23.27	5.30
	67 (19.4)	49.54	35.14	3.19	47.35	34.25	3.49	45.00	33.30	3.85	42.43	32.28	4.25	39.60	31.16	4.72	36.51	29.95	5.26
	63 (17.2)	46.06	33.82	3.16	44.05	32.94	3.47	41.89	32.00	3.82	39.52	30.98	4.22	36.90	29.87	4.69	34.04	28.66	5.23
	62 (16.7)	45.44	41.73	3.15	43.53	40.82	3.46	41.48	39.82	3.81	39.37	39.37	4.22	37.22	37.22	4.70	34.80	34.80	5.24
1600	72 (22.2)	55.17	29.90	3.30	52.64	28.99	3.61	49.92	28.01	3.96	46.96	26.96	4.37	43.72	25.83	4.84	40.19	24.61	5.38
	67 (19.4)	50.36	37.46	3.27	48.09	36.55	3.57	45.64	35.59	3.93	42.97	34.53	4.34	40.05	33.39	4.81	36.86	32.13	5.34
	63 (17.2)	46.86	35.98	3.24	44.77	35.09	3.55	42.51	34.12	3.90	40.05	33.08	4.31	37.35	31.93	4.77	34.40	30.67	5.31
	62 (16.7)	46.51	44.79	3.24	44.64	44.64	3.55	42.79	42.79	3.90	40.73	40.73	4.31	38.42	38.42	4.79	35.83	35.83	5.33
1800	72 (22.2)	55.79	31.25	3.38	53.16	30.32	3.69	50.36	29.34	4.04	47.31	28.27	4.45	43.97	27.12	4.92	40.37	25.89	5.46
	67 (19.4)	50.98	39.68	3.35	48.82	38.75	3.65	46.10	37.76	4.01	43.37	36.69	4.42	40.37	35.50	4.89	37.14	34.18	5.42
	63 (17.2)	47.47	38.04	3.32	45.30	37.12	3.63	42.98	36.13	3.98	40.45	35.06	4.39	37.69	33.87	4.86	34.70	32.54	5.39
	62 (16.7)	47.80	47.80	3.32	45.99	45.99	3.63	44.00	44.00	3.99	41.81	41.81	4.40	39.36	39.36	4.88	36.64	36.64	5.42
	57 (13.9)	47.74	47.74	3.32	45.93	45.93	3.63	43.95	43.95	3.99	41.76	41.76	4.40	39.32	39.32	4.87	36.60	36.60	5.41

EVAPORATOR AIR		CONDENSER ENTERING AIR TEMPERATURES °F (°C)																	
CFM	EWB °F (°C)	75 (23.9)			85 (29.4)			95 (35)			105 (40.6)			115 (46.1)			125 (51.7)		
		Capacity MBtuh		Total Sys KW**	Capacity MBtuh		Total Sys KW**	Capacity MBtuh		Total Sys KW**	Capacity MBtuh		Total Sys KW**	Capacity MBtuh		Total Sys KW**	Capacity MBtuh		Total Sys KW**
		Total	Sens†		Total	Sens†		Total	Sens†		Total	Sens†		Total	Sens†		Total	Sens†	
24AHA460A30 Outdoor Section With CNPV*6124AL* Indoor Section																			
1750	72 (22.2)	68.86	34.68	4.09	65.73	33.57	4.48	62.37	32.40	4.93	58.68	31.12	5.45	54.65	29.75	6.04	50.21	28.26	6.71
	67 (19.4)	62.81	42.85	4.03	60.01	41.76	4.42	57.00	40.60	4.87	53.69	39.34	5.39	50.05	37.96	5.98	46.03	36.46	6.65
	63 (17.2)	58.41	41.24	3.99	55.85	40.17	4.38	53.11	39.03	4.82	50.06	37.78	5.34	46.70	36.41	5.93	42.98	34.90	6.59
	62 (16.7)	57.61	50.93	3.98	55.17	49.82	4.37	52.58	48.59	4.82	49.93	49.93	5.34	47.15	47.15	5.94	44.00	44.00	6.61
2000	72 (22.2)	69.94	36.44	4.19	66.66	35.31	4.58	63.14	34.10	5.04	59.32	32.81	5.56	55.14	31.41	6.15	50.56	29.90	6.81
	67 (19.4)	63.84	45.70	4.14	60.93	44.59	4.53	57.78	43.40	4.98	54.34	42.10	5.49	50.59	40.69	6.08	46.45	39.14	6.75
	63 (17.2)	59.43	43.90	4.09	56.76	42.80	4.48	53.87	41.62	4.93	50.72	40.34	5.44	47.25	38.93	6.03	43.42	37.37	6.70
	62 (16.7)	58.98	54.67	4.09	56.66	56.66	4.48	54.28	54.28	4.94	51.61	51.61	5.46	48.63	48.63	6.06	45.27	45.27	6.73
2250	72 (22.2)	70.70	38.10	4.29	67.30	36.94	4.68	63.68	35.72	5.14	59.73	34.41	5.66	55.44	32.99	6.25	50.77	31.46	6.91
	67 (19.4)	64.61	48.42	4.24	61.59	47.28	4.63	58.35	46.06	5.08	54.82	44.74	5.59	50.98	43.27	6.18	46.79	41.64	6.85
	63 (17.2)	60.18	46.42	4.19	57.41	45.29	4.58	54.45	44.09	5.03	51.21	42.77	5.55	47.66	41.31	6.13	43.79	39.65	6.80
	62 (16.7)	60.66	60.66	4.20	58.34	58.34	4.59	55.79	55.79	5.05	52.96	52.96	5.57	49.81	49.81	6.17	46.25	46.25	6.84
	57 (13.9)	60.58	60.58	4.20	58.27	58.27	4.59	55.72	55.72	5.05	52.90	52.90	5.57	49.75	49.75	6.17	46.20	46.20	6.84

† Total and sensible capacities are net capacities. Blower motor heat has been subtracted.

‡ Sensible capacities shown are based on 80°F (27°C) entering air at the indoor coil. For sensible capacities at other than 80°F (27°C), deduct 835 Btuh (245 kW) per 1000 CFM (480 L/S) of indoor coil air for each degree below 80°F (27°C), or add 835 Btuh (245 kW) per 1000 CFM (480 L/S) of indoor coil air per degree above 80°F (27°C).

** System kw is total of indoor and outdoor unit kilowatts.

EWB — Entering Wet Bulb

NOTES:

- Detailed cooling capacities are based on indoor and outdoor unit at the same elevation per AHRI standard 210/240–2008. If additional tubing length and/or indoor unit is located above outdoor unit, a slight variation in capacity may occur.
- When the required data falls between the published data, interpolation may be performed. Extrapolation is not an acceptable practice.

CONDENSOR ONLY RATINGS

SST °F (°C)		CONDENSER ENTERING AIR TEMPERATURES °F (°C)							
		55 (12.78)	65 (18.33)	75 (23.89)	85 (29.44)	95 (35.0)	105 (40.56)	115 (46.11)	125 (51.67)
24AHA418A30									
30 (-1.11)	TCG	16.60	15.60	14.70	13.80	12.90	12.00	11.10	10.10
	SDT	68.50	78.00	87.50	97.00	106.50	116.00	125.40	134.70
	KW	0.76	0.87	0.99	1.11	1.25	1.40	1.59	1.80
35 (1.67)	TCG	18.30	17.20	16.30	15.30	14.30	13.30	12.30	11.20
	SDT	69.70	79.20	88.70	98.20	107.60	117.00	126.30	135.50
	KW	0.76	0.87	0.99	1.11	1.25	1.41	1.59	1.80
40 (4.44)	TCG	20.00	19.00	17.90	16.90	15.80	14.70	13.60	12.40
	SDT	71.10	80.50	89.90	99.40	108.70	118.00	127.20	136.30
	KW	0.77	0.88	0.99	1.11	1.25	1.41	1.59	1.80
45 (7.22)	TCG	22.00	20.80	19.70	18.50	17.40	16.20	14.90	13.60
	SDT	72.50	81.90	91.30	100.60	109.80	119.00	128.20	137.20
	KW	0.77	0.88	0.99	1.12	1.26	1.41	1.59	1.80
50 (10.0)	TCG	24.00	22.80	21.60	20.40	19.10	17.80	16.40	15.00
	SDT	74.00	83.40	92.60	101.90	111.00	120.10	129.20	138.20
	KW	0.77	0.88	0.99	1.12	1.26	1.41	1.59	1.80
55 (12.78)	TCG	26.30	25.00	23.60	22.30	20.90	19.50	18.00	16.40
	SDT	75.60	84.80	94.10	103.20	112.30	121.30	130.30	139.20
	KW	0.78	0.88	1.00	1.12	1.26	1.42	1.60	1.80
24AHA424A30									
30 (-1.11)	TCG	21.40	20.20	19.00	17.80	16.60	15.40	14.20	12.90
	SDT	71.90	81.30	90.70	100.00	109.30	118.50	127.70	136.80
	KW	1.01	1.15	1.30	1.46	1.64	1.85	2.09	2.36
35 (1.67)	TCG	23.50	22.20	20.90	19.60	18.30	17.00	15.60	14.20
	SDT	73.50	82.80	92.10	101.30	110.50	119.60	128.70	137.70
	KW	1.02	1.16	1.30	1.47	1.65	1.86	2.09	2.37
40 (4.44)	TCG	25.70	24.40	23.00	21.60	20.20	18.70	17.20	15.60
	SDT	75.10	84.30	93.50	102.60	111.80	120.80	129.80	138.80
	KW	1.02	1.16	1.31	1.47	1.66	1.86	2.10	2.38
45 (7.22)	TCG	28.20	26.70	25.20	23.70	22.10	20.50	18.90	17.10
	SDT	76.70	85.90	95.00	104.10	113.10	122.10	131.00	139.80
	KW	1.03	1.17	1.32	1.48	1.66	1.87	2.11	2.39
50 (10.0)	TCG	30.80	29.20	27.50	25.90	24.20	22.40	20.60	18.70
	SDT	78.50	87.50	96.60	105.60	114.60	123.40	132.20	140.90
	KW	1.04	1.18	1.32	1.49	1.67	1.88	2.12	2.39
55 (12.78)	TCG	33.60	31.80	30.10	28.30	26.40	24.50	22.40	20.30
	SDT	80.30	89.30	98.30	107.20	116.10	124.90	133.50	142.00
	KW	1.05	1.18	1.33	1.50	1.68	1.89	2.13	2.40
24AHA430A30									
30 (-1.11)	TCG	27.20	25.80	24.40	22.90	21.40	19.70	17.90	16.00
	SDT	69.90	79.20	88.60	98.00	107.30	116.60	125.80	134.80
	KW	1.22	1.39	1.57	1.77	2.00	2.27	2.58	2.94
35 (1.67)	TCG	30.10	28.50	27.00	25.40	23.70	21.90	20.00	17.90
	SDT	71.20	80.60	89.90	99.20	108.50	117.70	126.80	135.80
	KW	1.22	1.40	1.58	1.78	2.01	2.28	2.58	2.94
40 (4.44)	TCG	33.10	31.40	29.70	28.00	26.20	24.30	22.20	20.00
	SDT	72.70	82.00	91.20	100.50	109.70	118.90	127.90	136.90
	KW	1.23	1.41	1.59	1.80	2.03	2.29	2.59	2.94
45 (7.22)	TCG	36.50	34.50	32.70	30.80	28.80	26.80	24.50	22.10
	SDT	74.30	83.50	92.70	101.90	111.00	120.10	129.10	137.90
	KW	1.25	1.43	1.61	1.82	2.05	2.31	2.60	2.95
50 (10.0)	TCG	40.00	37.90	35.80	33.80	31.60	29.40	27.00	24.40
	SDT	76.00	85.10	94.20	103.40	112.40	121.40	130.30	139.00
	KW	1.27	1.45	1.64	1.84	2.07	2.33	2.62	2.95
55 (12.78)	TCG	43.80	41.40	39.20	36.90	34.60	32.10	29.50	26.70
	SDT	77.90	86.90	95.90	104.90	113.90	122.80	131.50	140.20
	KW	1.29	1.47	1.66	1.87	2.09	2.35	2.64	2.97

See notes on page 15

CONDENSER ONLY RATINGS (CONTINUED)

SST °F (°C)		CONDENSER ENTERING AIR TEMPERATURES °F (°C)							
		55 (12.78)	65 (18.33)	75 (23.89)	85 (29.44)	95 (35.0)	105 (40.56)	115 (46.11)	125 (51.67)
24AHA436A30									
30 (-1.11)	TCG	31.40	29.80	28.20	26.40	24.60	22.70	20.60	18.50
	SDT	68.70	78.10	87.50	96.80	106.20	115.50	124.70	134.00
	KW	1.48	1.69	1.91	2.14	2.40	2.69	3.04	3.44
35 (1.67)	TCG	34.70	32.90	31.10	29.20	27.20	25.10	22.80	20.50
	SDT	70.00	79.30	88.60	97.90	107.20	116.40	125.60	134.80
	KW	1.48	1.70	1.91	2.15	2.41	2.70	3.05	3.45
40 (4.44)	TCG	38.20	36.20	34.20	32.10	29.90	27.60	25.20	22.60
	SDT	71.30	80.50	89.80	99.10	108.30	117.40	126.50	135.60
	KW	1.49	1.70	1.92	2.16	2.42	2.72	3.06	3.45
45 (7.22)	TCG	42.00	39.80	37.60	35.30	32.90	30.30	27.70	24.80
	SDT	72.80	81.90	91.10	100.30	109.40	118.50	127.50	136.40
	KW	1.50	1.72	1.94	2.18	2.44	2.73	3.07	3.46
50 (10.0)	TCG	46.00	43.60	41.10	38.60	36.00	33.20	30.20	27.20
	SDT	74.40	83.40	92.50	101.60	110.60	119.60	128.50	137.30
	KW	1.52	1.74	1.96	2.20	2.46	2.75	3.08	3.47
55 (12.78)	TCG	50.20	47.60	44.90	42.10	39.20	36.20	32.90	29.60
	SDT	76.10	85.00	94.00	103.00	111.90	120.80	129.50	138.20
	KW	1.54	1.76	1.98	2.22	2.48	2.77	3.10	3.48
24AHA448A30									
30 (-1.11)	TCG	41.50	39.50	37.40	35.40	33.20	30.80	28.20	25.40
	SDT	73.40	82.60	91.90	101.20	110.40	119.50	128.60	137.50
	KW	2.05	2.30	2.57	2.87	3.21	3.60	4.05	4.56
35 (1.67)	TCG	45.70	43.40	41.20	38.90	36.50	33.90	31.10	28.10
	SDT	75.10	84.30	93.40	102.60	111.70	120.80	129.70	138.60
	KW	2.08	2.33	2.60	2.90	3.24	3.63	4.08	4.60
40 (4.44)	TCG	50.10	47.70	45.20	42.70	40.10	37.20	34.20	30.90
	SDT	77.00	86.00	95.10	104.10	113.20	122.10	131.00	139.70
	KW	2.12	2.36	2.63	2.93	3.27	3.67	4.12	4.64
45 (7.22)	TCG	54.80	52.20	49.50	46.70	43.80	40.70	37.40	33.80
	SDT	78.90	87.80	96.80	105.80	114.70	123.50	132.20	140.80
	KW	2.15	2.39	2.66	2.96	3.31	3.71	4.16	4.69
50 (10.0)	TCG	59.90	56.90	54.00	51.00	47.80	44.40	40.70	36.80
	SDT	80.90	89.80	98.60	107.50	116.30	125.00	133.60	142.00
	KW	2.19	2.43	2.70	3.00	3.34	3.74	4.20	4.72
55 (12.78)	TCG	65.20	62.00	58.80	55.40	51.90	48.20	44.20	39.90
	SDT	83.10	91.80	100.50	109.30	117.90	126.50	134.90	143.20
	KW	2.24	2.47	2.73	3.03	3.38	3.78	4.24	4.76
24AHA460A30									
30 (-1.11)	TCG	53.00	50.30	47.70	45.10	42.40	39.40	36.00	32.40
	SDT	76.00	85.10	94.30	103.50	112.70	121.70	130.60	139.40
	KW	2.59	2.90	3.23	3.61	4.03	4.52	5.08	5.71
35 (1.67)	TCG	58.30	55.30	52.50	49.70	46.60	43.30	39.70	35.70
	SDT	78.00	87.00	96.10	105.20	114.20	123.10	131.90	140.60
	KW	2.64	2.94	3.28	3.65	4.08	4.58	5.14	5.78
40 (4.44)	TCG	63.90	60.70	57.60	54.50	51.10	47.50	43.60	39.30
	SDT	80.00	88.90	97.90	106.90	115.80	124.70	133.30	141.90
	KW	2.69	2.99	3.32	3.70	4.14	4.63	5.20	5.84
45 (7.22)	TCG	70.00	66.50	63.10	59.60	55.90	51.90	47.60	42.90
	SDT	82.20	91.00	99.90	108.80	117.60	126.30	134.80	143.20
	KW	2.74	3.04	3.38	3.76	4.19	4.69	5.27	5.91
50 (10.0)	TCG	76.40	72.60	68.80	65.00	60.90	56.50	51.80	46.70
	SDT	84.60	93.30	102.00	110.70	119.40	127.90	136.30	144.50
	KW	2.80	3.10	3.43	3.81	4.25	4.76	5.33	5.97
55 (12.78)	TCG	83.30	79.10	74.90	70.60	66.10	61.30	56.10	50.60
	SDT	87.00	95.60	104.20	112.80	121.20	129.60	137.80	145.80
	KW	2.86	3.15	3.49	3.87	4.31	4.82	5.39	6.04

* AHRI listing applies only to systems shown in Combination Ratings table.

KW — Outdoor Unit Kilowatts Only.

SDT — Saturated Temperature Leaving Compressor (°F)

SST — Saturated Temperature Entering Compressor (°F/°C)

TCG — Gross Cooling Capacity (1000 Btuh)

GUIDE SPECIFICATIONS

GENERAL

System Description

Outdoor-mounted, air-cooled, split-system air conditioning unit suitable for ground or rooftop installation. Unit consists of a scroll-type hermetic compressor, an air-cooled coil, propeller-type condenser fan, and a control box. Unit will discharge supply air horizontally as shown on contract drawings. Unit will be used in a refrigeration circuit to match up to a packaged fan coil or furnace.

Quality Assurance

- Unit will be rated in accordance with the latest edition of AHRI Standard 210.
- Unit will be certified for capacity and efficiency, and listed in the latest AHRI directory.
- Unit construction will comply with latest edition of ANSI/ASHRAE and with NEC.
- Unit will be constructed in accordance with UL standards and will carry the UL label of approval. Unit will have c-UL approval.
- Unit cabinet will be capable of withstanding Federal Test Method Standard No. 141 (Method 6061) 500-hr salt spray test.
- Air-cooled condenser coils will be leak tested and pressure tested
- Unit constructed in ISO9001 approved facility.

Delivery, Storage, and Handling

- Unit will be shipped as single package only and is stored and handled per unit manufacturer's recommendations.

Warranty (for inclusion by specifying engineer)

- U.S. and Canada only.

PRODUCTS

Equipment

- Factory assembled, single piece, air-cooled air conditioning unit. Contained within the unit enclosure is all factory wiring, piping, controls, compressor, refrigerant charge Puron® (R-410A), and special features required prior to field start-up.

Unit Cabinet

- Unit cabinet will be constructed of galvanized steel and bonderized.

Fans

- Condenser fan will be direct-drive propeller type, discharging air horizontally.

AIR-COOLED, SPLIT-SYSTEM AIR CONDITIONER

24AHA4

1-1/2 TO 5 NOMINAL TONS

- Condenser fan motors will be totally enclosed, 1-phase type with class B insulation and permanently lubricated bearings. Shafts will be corrosion resistant.
- Fan blades will be statically and dynamically balanced.
- Condenser fan openings will be equipped with coated steel wire safety guards.

Compressor

- Compressor will be a scroll-type, hermetically sealed.
- Compressor will be mounted on rubber vibration isolators.

Condenser Coil

- Condenser coil will be air cooled.
- Coil will be constructed of aluminum fins mechanically bonded to copper tubes which are then cleaned, dehydrated, and sealed.

Refrigeration Components

- Refrigeration circuit components will include liquid-line front-seating shutoff valve with sweat connections, vapor-line front-seating shutoff valve with sweat connections, system charge of Puron® (R-410A) refrigerant, and compressor oil.
- Unit will be equipped with high-pressure switch and filter drier for Puron refrigerant.

Operating Characteristics

- The capacity of the unit will meet or exceed _____ Btuh at a suction temperature of _____ °F/°C. The power consumption at full load will not exceed _____ kW.
- Combination of the unit and the evaporator or fan coil unit will have a total net cooling capacity of _____ Btuh or greater at conditions of _____ CFM entering air temperature at the evaporator at _____ °F/°C wet bulb and _____ °F/°C dry bulb, and air entering the unit at _____ °F/°C.
- The system will have a SEER of _____ Btuh/watt or greater at DOE conditions.

Electrical Requirements

- Nominal unit electrical characteristics will be _____ v, single phase, 60 hz. The unit will be capable of satisfactory operation within voltage limits of _____ v to _____ v.
- Nominal unit electrical characteristics will be _____ v, three phase, 60 hz. The unit will be capable of satisfactory operation within voltage limits of _____ v to _____ v.
- Unit electrical power will be single point connection.
- Control circuit will be 24v.

Special Features

- Refer to section of this literature identifying accessories and descriptions for specific features and available enhancements.