



## Product Data

Indoor and Outdoor  
Air Handlers

Nominal 400 to 8,500 cfm



39SH,SV,SM,SR00-17

The 39S Series air handlers offer:

- Horizontal and vertical draw-thru arrangements for heating, cooling, ventilation, and VAV (variable air volume) applications
- Small footprint, which assures rigging ease and reduced space requirements

## Features/Benefits

**Delivering the air handler components for many stringent specification requirements, the 39S Series air handlers are compact and combine versatility with economical, dependable performance.**

### Dependable performance

**Galvanized steel panels reduce** the likelihood of corrosion to help maintain structural integrity under most operating conditions. Double-walled hinged access doors on outdoor units also enhance structural stability and provide fast, easy access.

**Optional stainless steel drain pan** controls condensate.

**Internally mounted motors and drives** are installed and aligned at the factory. Because they are contained in a cooled, filtered, dehumidified

airstream, motor bearings and belts have less wear and require less servicing than motors mounted externally. Internal mounting also reduces installation time, shipping damage, and vandalism.

**Precision-balanced fan wheels** limit vibration and reduce abnormal stress on bearings and other components.

**Motor start/stop station** is an available motor option that provides convenient motor control outside the unit cabinet.

**Direct drive plenum fan** option eliminates belts from the system and improves efficiency.

**Fan bearings are rated at** 200,000 hours average life.

**Mixing boxes and filter mixing boxes** have parallel blades to provide thorough, efficient air mixing. Dampers are sectioned to prevent excess blade warping and ensure tight closure.

**HEPA level filtration** is available as an option for applications that maintain high IAQ requirements.

### Economy

**Factory assembled, pre-aligned drives and fans** eliminate field installation expense, saving money.

Carrier 39S air handlers are rated in accordance with AHRI Standard 430, which is the industry standard for central station air-handling units. Certification by participating manufacturers of units within the scope of this program requires that the ratings and performance of any central station unit certified to AHRI be established in accordance with the AHRI Standard.

**Small envelope size** is easy to rig and ensures economical use of building space. Quicker, easier installation and set-up reduce start-up costs.

**Entirely vertical option** minimizes the unit footprint to maximize space in the mechanical room.

**Hinged access doors** on outdoor, double wall units ease service and access as compared to fixed panels, saving time and money.

### Coil flexibility

The 39S units offer a wide selection of coils for cooling, heating, preheat with cooling, or cooling with reheat application.

**Chilled water, DX (direct expansion), and steam coils** are available for most product lines in both standard and high capacities, while hot water coils are available in 1, 2, 4 and 6 rows for most product lines. The DX coils come equipped with factory-installed TXVs (thermostatic expansion valves) and nozzles.

- Biflow TXVs for units under 5 tons allow for use with heat pumps.
- Heat pump kits are available for units from 5 to 10 tons.

Single circuit and face splits are also available.

**Electric heaters** are available over a wide kilowatt range in a number of voltages.

The following items are not within the scope of the AHRI Central Station Air Handlers Certification program:

- sound ratings
- electric heating coil ratings

## AHRI certification

The Air-Conditioning, Heating and Refrigeration Institute (AHRI) is a voluntary, nonprofit organization comprised of the manufacturers of air conditioning, refrigeration, and heating products. More than 90% of the air conditioning and refrigeration machinery and components manufactured in the United States is produced by members of AHRI.



# Model number nomenclature



Due to the complexity of the 39S model number, use the “verify model number” function in the **AHUBuilder**® software for a detailed model explanation.

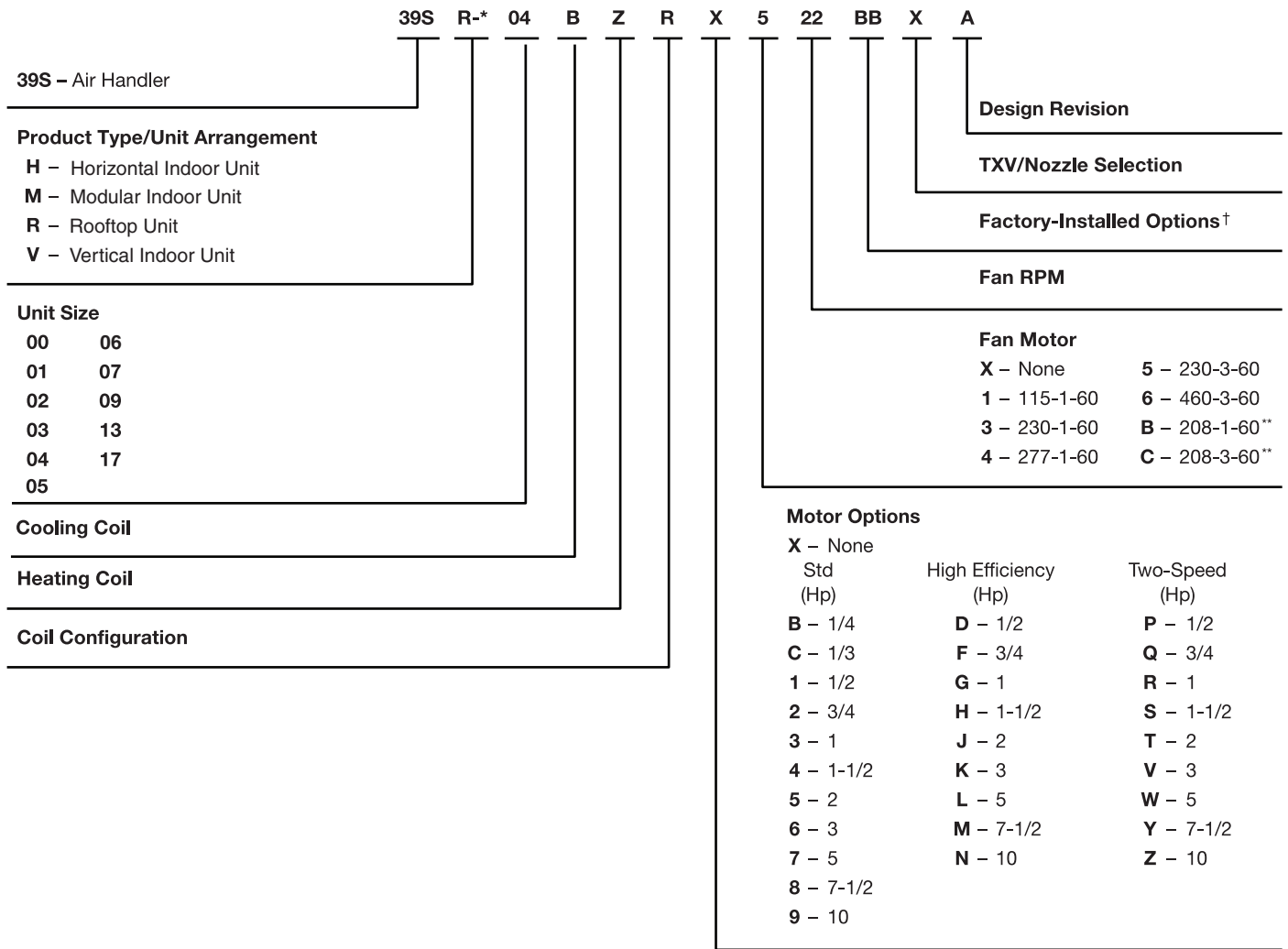

## LEGEND

**TXV** — Thermostatic Expansion Valve

\*Contact your local Carrier representative for a list of available unit arrangements.

†See page 4 for a list of factory-installed options.

\*\*Unit shall be factory wired. Field must switch transformer tap (if provided) to 208v.

## Table of contents

	Page
Features/Benefits . . . . .	2
AHRI Certification . . . . .	2
Model Number Nomenclature . . . . .	3
Factory-Installed Options . . . . .	4
Application Data . . . . .	5 - 14
Selection Procedure . . . . .	15, 16
Performance Data . . . . .	17 - 30
Dimensions . . . . .	31 - 50
Physical Data . . . . .	51 - 53
Guide Specifications . . . . .	54 - 58

# Factory-installed options



ITEM	39S UNIT TYPE					
	SHK	SV	SM	SR	SHC	SHF
MERV 8, 2 in. Pleated Filter	Std	Std	Std	Std	Std	Std
Indoor Air Quality (IAQ) Insulation	Std	Std	X	X	Std	Std
Closed Cell Insulation	X	X	X	X	—	—
Double Wall Insulation	X	X		X	Std	Std
Motor Start/Stop Station*	X	X	X	—	—	—
Plastic Drain Pan†	Std/—	Std/X	—	—	—	—
Stainless Steel Drain Pan**	Std/X	Std/X	X	X	Std	Std
Galvanized Steel Drain Pan	—	Std/X	Std	Std	—	—
4 in. Pleated Filter, MERV 13	—	—	—	—	Std	Std
Final 12 in. Filter, HEPA Type A, 99.975%	—	—	—	—	—	X
Final 12 in. Filter, MERV 14	—	—	—	—	—	X
VFD (Variable Frequency Drive)	—	—	—	—	Std	Std

## LEGEND

- Std — Standard Item
- X — Optional Item
- — Unavailable Item
- Std/— — Standard or Unavailable Item Depending on Unit Size
- Std/X — Standard or Optional Item Depending on Unit Size

\*Motor start/stop station is not available with electric heat on 39SHK units or on any unit with 2-speed motors.  
 †Plastic drain pan is standard on 39SHK,SV02-09 units and not available on 39SHK00,01,13,17 or 39SV13,17 units.  
 \*\*Stainless steel drain pan is not available on 39SV02-09 units.

## Factory-installed options

**Filters** — Two-inch MERV 8 throwaway filters are standard on all 39S units. The SHF model has increased filtration capabilities.

**Insulation** — The 39S unit has a minimum  $\frac{3}{4}$  in. insulation thickness. Several insulation options are available along with a double-wall finish in order to meet various job-site requirements.

### INSULATION OPTIONS

INSULATION TYPE	39S UNIT TYPE					
	SHK	SV	SM	SR	SHC	SHF
Tuf-Skin* II	—	—	$\frac{3}{4}$	1	—	—
Exact-O-Kote* IAQ	1	1	1	1	2	2
Closed Cell	$\frac{7}{8}$	$\frac{7}{8}$	$\frac{3}{4}$	$\frac{7}{8}$	—	—
Double Wall	1	1	—	1	2	2
Double Wall with Agion	—	—	—	—	2	2

\*Tuf-Skin and Exact-O-Kote are trademarks of Johns Manville, Inc.

NOTE: Dimensions are in inches and indicate insulation thickness.

**Electrical options** — Junction boxes are standard on all 39S air handlers. Motor start/stop stations are available on most units for unit fan motor control. Variable frequency drives are standard on 39SHC and 39SHF air handles.

**Drain pans** — The 39S air handler offers a wide array of drain pan finishes. Plastic and galvanized coatings are offered as low-cost options. Stainless steel is also available, providing an easy-to-clean, corrosion resistant surface.

## Central station air handler

The central station air handler is a heating, ventilating, or air-conditioning unit that is centrally located in, or on, a building or structure and from which air is distributed to desired areas through a system of ducts.

### The 39S factory packaged unit

Individual components, such as fans, coils, and filters, are assembled at the factory.

Packaged equipment is less costly than field-fabricated equipment and does not require assembly.

The basic air-handling unit consists of a fan section, coil section, and filter. Other components, such as air-mixing boxes and damper sections, may also be provided.

## Central station configurations

### Draw-thru units

#### Horizontal

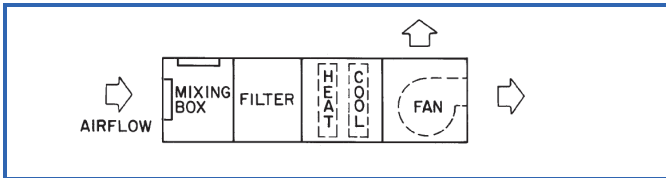

### Vertical (indoor unit only)

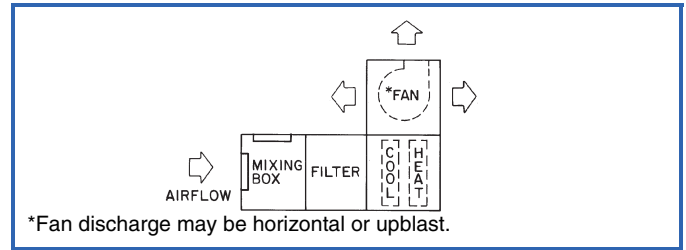

### Fans

The 39S central station air handlers use belt-driven centrifugal fans or direct drive plenum fans. A centrifugal fan is one in which the air flows radially through the impeller. Centrifugal fans are classified according to fan wheel and blade construction. Plenum fans are selected as single width, single inlet (SWSI) with airfoil blades.

### Laws of fan performance

Fan laws are used to predict fan performance under changing operating conditions or by fan size. They are applicable to all types of fans.

The fan laws are stated below. The symbols used in the formulas represent the following variables:

*CFM* — Volume rate of flow through the fan.

*RPM* — Rotational speed of the impeller.

*P* — Pressure developed by the fan.

*Hp* — Horsepower input to the fan.

*D* — Fan wheel diameter. The fan size number can be used if it is proportional to the wheel diameter.

*W* — Air density, varying directly as the barometric pressure and inversely as the absolute temperature.

Application of these laws is limited to cases where fans are geometrically similar.

## FAN LAWS

VARIABLE	CONSTANT	LAW	FORMULA
SPEED (RPM)	Air Density Fan Size Distribution System	Airflow varies directly with the Speed.	$\frac{CFM_1}{CFM_2} = \frac{RPM_1}{RPM_2}$
		Pressure varies as the square of the Speed.	$\frac{P_1}{P_2} = \left(\frac{RPM_1}{RPM_2}\right)^2$
		Horsepower varies as the cube of the Speed.	$\frac{Hp_1}{Hp_2} = \left(\frac{RPM_1}{RPM_2}\right)^3$
FAN SIZE (D)	Air Density Tip Speed	Capacity and Horsepower vary as the square of the Fan Size.	$\frac{CFM_1}{CFM_2} = \frac{Hp_1}{Hp_2} = \left(\frac{D_1}{D_2}\right)^2$
		Speed varies inversely as the Fan Size.	$\frac{RPM_1}{RPM_2} = \frac{D_2}{D_1}$
		Pressure remains constant.	$P_1 = P_2$
	Air Density Wheel Speed	Capacity varies as the cube of the Size.	$\frac{CFM_1}{CFM_2} = \left(\frac{D_1}{D_2}\right)^3$
		Pressure varies as the square of the Size.	$\frac{P_1}{P_2} = \left(\frac{D_1}{D_2}\right)^2$
		Horsepower varies as the fifth power of the Size.	$\frac{Hp_1}{Hp_2} = \left(\frac{D_1}{D_2}\right)^5$
AIR DENSITY (W)	Pressure Fan Size Distribution System	Speed, Capacity, and Horsepower vary inversely as the square root of Density.	$\frac{RPM_1}{RPM_2} = \frac{CFM_1}{CFM_2} = \frac{Hp_1}{Hp_2} = \left(\frac{W_2}{W_1}\right)^{1/2}$
		Pressure and Horsepower vary with Density.	$\frac{P_1}{P_2} = \frac{Hp_1}{Hp_2} = \frac{W_1}{W_2}$
	Airflow Fan Size Distribution System	Speed remains constant.	$RPM_1 = RPM_2$



# Application data (cont)



## Fan selection criteria

**System requirements** — The major factors that influence fan selection are airflow, external static pressure, fan speed, brake horsepower, and sound level. Additional system considerations include the fan control method, overloading, and non-standard air density. Fan selection for air-conditioning service usually involves choosing the smallest fan that provides an acceptable level of performance, efficiency, and quality.

**Pressure considerations** — The static pressure is the resistance of the combined system apart from the fan. Contributors to static pressure include other components in the air handler, ductwork, and terminals. The static pressure is dependent on the airflow through the system, which is determined by the air conditioning requirements. As shown in the second fan law in the table on the preceding page, the static pressure varies as the square of the airflow (cfm). This ratio between pressure and airflow determines the system curve for any air-handling system.

The static pressure used to select a fan should be the pressure calculated for the system at design airflow. If the static pressure is overestimated, the amount of increase in horsepower and air volume depends upon the steepness of the fan curves in the area of selection.

With forward-curved (FC) fans, if the actual static pressure of the system is less than the design static pressure, the fan has a tendency to deliver more air and draw correspondingly higher bhp (kW of energy). This higher current draw may overload the motor and trip circuit breakers. This is a common occurrence when FC centrifugal fans are operated before all the ductwork has been installed, or during the pull-down load on a VAV (variable air volume) system.

**Stability** — Fan operation is stable if it remains unchanged after a slight temporary disturbance, or if the fan operation point shifts to another location on the fan curve after a slight permanent disturbance. Fan operation is unstable if it fluctuates repeatedly or erratically. There are 2 main types of unstable fan operation:

*System surge* is a cycling increase and decrease in system static pressure.

*Fan stall* is the most common type of instability, and it occurs with any type of centrifugal fan when the fan is starved for air.

Normally, the rotation of the fan wheel forces the air through the blade passageway from the low pressure to the high pressure side of the fan. If the airflow is restricted too much, however, there is not enough air to fill the space between the blades and the air distribution between the blades becomes uneven and erratic. Air can flow backwards through the wheel and the noise level is substantially increased. If the fan runs in this condition for a long time, wheel failure is likely to occur.

For a given speed, the operating point where a fan stalls is a function of the wheel geometry and wheel speed. In general, the stall point is within the range of 15 to 25% of the airflow obtained at free delivery.

**Stability and VAV applications** — Special considerations must be made for VAV systems. While the initial fan

selection may be acceptable, its operating point could shift to a point of stall at minimum airflow and pressure conditions. The typical minimum airflow is half of the design cooling airflow, which is also often equal to the heating airflow. To determine and plot the minimum airflow versus static pressure, use the following equation. This equation solves for the static pressure at a specific airflow based on a minimum static pressure set point:

$$\left( \left( \frac{CFM_1}{CFM_{DESIGN}} \right)^2 \times (SP_{DESIGN} - SP_{MIN}) \right) + SP_{MIN} = SP_1$$

$$\left( \left( \frac{7,500}{15,000} \right)^2 \times (4 - 2) \right) + 2 = 2.50 \text{ in. wg}$$

**CFM** — Airflow in Cubic Feet Per Minute  
**SP** — Static Pressure

The table below illustrates a system with an airfoil fan wheel at a cooling design of 15,000 cfm and a system static pressure of 4 in. wg. The minimum airflow is 7,500 cfm with a minimum system static pressure set point of 2 in. wg. **The minimum static set point is based on zero airflow and does not coincide with the minimum design airflow.**

Example:

% AIRFLOW	CFM	SYSTEM AND FAN STATIC PRESSURE (in. wg)
100	15,000	4.00
90	13,500	3.62
80	12,000	3.28
70	10,500	2.98
60	9,000	2.72
50	7,500	2.50

As shown on the highlighted VAV curve, the minimum airflow and static pressure (MP) are both well within the acceptable operating conditions of the fan.

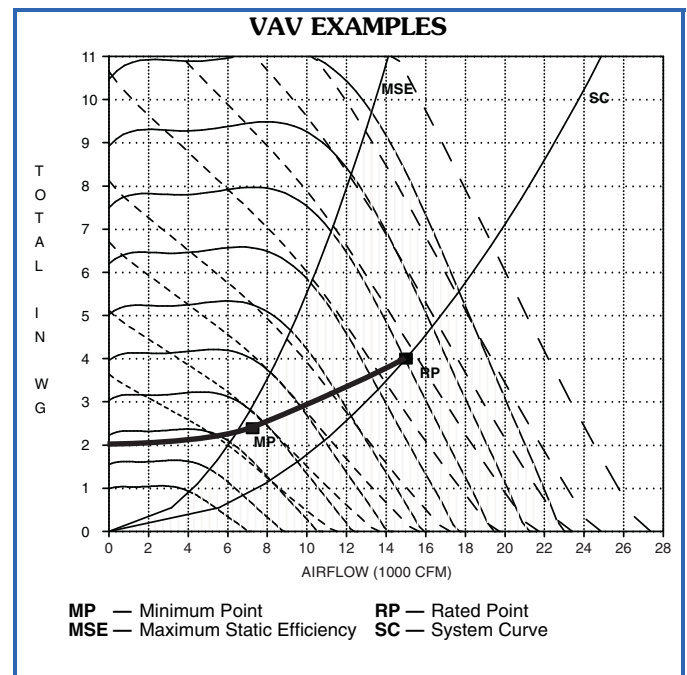

**Sound considerations** — The fan is one of the main sound sources in an air-conditioning system. Other sources of sound include the duct system and terminals, because they generate turbulence in the air flowing through them. Simply estimating fan sound does not give an accurate picture of total system sound, but because fan sound is a major component of system sound, fan sound should be minimized.

To minimize its sound generation, a fan must be correctly sized and should be selected to operate at or near peak efficiency. Oversized fans can generate much higher sound power levels than necessary, especially in VAV systems operating at low airflows. Undersized fans can also result in higher sound power levels because of increased fan speeds and the higher tip velocity of the air leaving the fan blades.

For VAV systems, the part load point at which the fan operates most of the time should be used to select a fan for lowest sound output.

Variable frequency drives (VFDs) are used to modulate fan volume. A VFD reduces the sound power level as the fan speed is reduced. At 50% load, the sound level is reduced approximately 15 dB compared to the sound level at 100% load. When using variable frequency drives, it is important to be sure that the static deflection of the vibration isolators is adequate. At very low fan speeds, the fan frequency may approach the natural frequency of the spring isolation. If this happens, the vibration levels can be amplified and resonant vibration conditions can occur.

When sound level is a major consideration, a blow-thru fan should be considered because of the reduced discharge sound level. This sound reduction is due to the sound absorption of the coil section downstream from the fan. Transition fittings and elbows can be reduced in size or eliminated, thereby eliminating a sound source.

To obtain projected sound data for a selected 39S unit, use the electronic catalog **AHUBuilder**<sup>®</sup> program.

**Dirty filtration considerations** — Consider selecting an air handler with dirty filters so that, in theory, the unit will have enough horsepower to deliver the same amount of air when the filters are dirty. On a constant volume unit, that would only work if the unit contained an airflow measuring station and could adjust the flow accordingly via a VFD. Otherwise, the point of operation moves along the RPM line as the static pressure in the system changes.

What happens when the fan with sheaves selected for dirty filters is ordered? Three things:

1. The air balancer forces the selection of a smaller sheave because the airflow is too high. When the filters load up, airflow is reduced.
2. If an air balance is not performed, the cooling coil may exhibit moisture carryover due to the considerable increase in airflow.
3. The fan motor trips out on overload with the forward-curved fan because of the increase in bhp.

Example:

Forward-curved fan, 6,100 cfm, 1333 rpm, 5.8 bhp, selected with 100% 2 in. pleated filters. Dirty filters result in a total static pressure (TSP) of 3.56 inches.

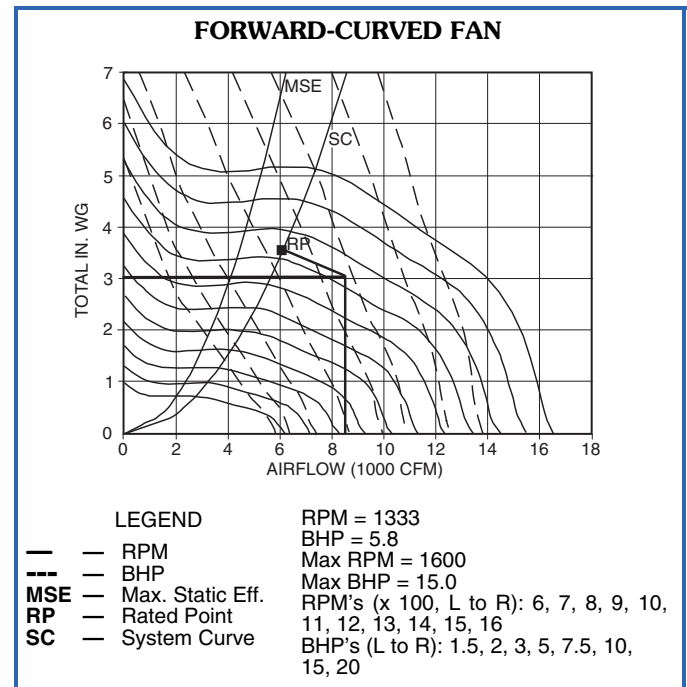

Clean filters result in a TSP of 3.06 in.

Follow the 1333 rpm line down to 3.06 in.

Clean filter cfm will be 8,500 cfm. Also note that the horsepower goes from 5.8 bhp to about 9 bhp because the FC fan is an overloading type fan.

So, if dirty filters need to be taken into consideration, do one of the following:

1. Make the final fan selection with the **clean** filter rpm but use the motor horsepower requirement for **dirty** filters.
2. Make the final fan selection with the **dirty** filter rpm and use the motor horsepower requirement for **dirty** filters — **only if** the engineer plans on using a VFD and airflow measurement station or if it is a VAV system.

**Fan, motor, and drive heat considerations** — The work output of a fan and its motor and drive contribute directly to the airflow and pressure exiting the air handler. Not all of the energy output of the fan generates airflow, however. Fan motors are not 100% efficient, and their efficiency loss translates directly into heat that must be factored in when calculating the temperature rise across a fan section. Fans also add a certain amount of heat to the airstream due to the effects of compression and bearing friction. Finally, belt drives do not transmit all of the energy generated by the motor. Some of the energy is lost in the form of heat due to belt tension and the type and number of belts. Belt drive bhp losses range from 2 to 6 percent; a 3% loss is typical.

Because the 39S Series air handlers all have their fans, motors, and drives located within the airstream, heat losses from these components affect the power requirements, cooling load, and heating load.

Power losses in the motor and drive should be allowed for when determining the motor output (bhp), so that the motor can be correctly sized and so that the additional heat output can be subtracted from cooling capacity or added to heating capacity. A typical example follows:

Given Fan Operating Point:

13,224 cfm  
9.6 Fan bhp  
3.0% estimated drive loss

Calculate the required fan motor output ( $H_p$ ) due to drive loss:

$H_p = (\text{Fan bhp}) \times (\text{Drive Loss})$   
 $H_p = 9.6 \times 1.03$   
 $H_p = 9.89 \text{ hp (select 10 Hp motor)}$

Calculate the total fan motor heat output (Q) according to motor efficiency:

$Q = (\text{Motor Output}) \div (\text{Motor Efficiency [Typical]})$   
 $Q = 9.89 \div 0.86$   
 $Q = 11.5 \text{ hp}$

Convert horsepower to Btu per hour.

$11.5 \text{ hp} \times 2545 = 29,268 \text{ Btuh}$

Calculate the increase in leaving-air temperature ( $\Delta T$ ) due to fan and motor heat and drive losses:

$Q = 1.1 \times \text{cfm} \times \Delta T$   
 $29,268 \text{ Btuh} = 1.1 \times 13,224 \times \Delta T$   
 $29,268 \text{ Btuh} = 14,546.4 \times \Delta T$   
 $\Delta T = 2.01 \text{ F (use to estimate coil requirements)}$

## Fan application

Certain fans are more efficient in low-static pressure systems, while others operate best in higher pressure systems. Some fan types are designed to handle very large air volumes while others are more efficient at lower volumes. The low cost 39S unit is designed for use with low-static pressure systems and is only available with forward-curved fans. For higher static applications, specify 39M or 39CC units.

**Forward-curved (FC) fans** are typically used for low to medium pressure applications (0 to 5 in. wg total static pressure [TSP]).

The FC fans are reasonably stable over a wide airflow (cfm) range at constant speed. Because of the relatively flat curve, FC fans tolerate modulation in airflow without large increases in static pressure. Most important, FC fans are lowest in first cost.

**Plenum fans** (sometimes called “plug” fans) are typically used in medium to high static pressure applications where ductwork requires discharge location flexibility. They can reduce the need for ductwork turns or diffusers, especially when equipment room space is limited.

Plenum fans are less efficient than double-width, double-inlet airfoil fans. General construction also differs from that of FC or AF fans. The fan does not have a scroll to enclose the fan wheel and direct airflow. Instead, the entire interior of the plenum fan section is pressurized by the fan.

Plenum fans have single-width, single-inlet (SWSI) construction. The fan shaft is parallel with the airflow, and the motor and bearings are located inside the plenum in the pressurized airstream. An optional inlet screen and wheel cage can be installed to help protect personnel during maintenance.

Plenum fans are generally used where there are space limitations, a need for discharge flexibility, a need for reduced discharge sound, or where duct configurations might change in the future. For example, in an application where there is not enough room in the building for a large main duct, several smaller duct runs may approach the mechanical equipment room from all sides. In such an application, several connections can be made to one or more sides of the plenum fan section. Installing contractors can cut outlets in the plenum box at the time of installation to suit the conditions at the jobsite.

Because the casing of a plenum fan section acts as a sound attenuator, plenum fans are also sometimes used when discharge sound levels need to be reduced.

Duct takeoffs from plenum fans can have relatively high pressure losses and can also create turbulence that causes a larger pressure drop across coil and filter sections. When selecting a plenum fan, the pressure drop for the duct takeoffs must be added to the external static pressure for the rest of the system.

**To calculate the pressure losses from plenum fan duct takeoffs, use the following formula and refer to the figure at right.**

$$P_l = P_p - P_d = (C_v) (V_p)$$

Where  $P_l$  is the pressure loss,  $P_p$  is the plenum pressure,  $P_d$  is the duct pressure,  $C_v$  is the pressure loss coefficient, and  $V_p$  is the velocity pressure in the duct. Note that for radial duct takeoffs,  $C_v$  is 1.5 in. wg, while for axial duct takeoffs,  $C_v$  is 2.0 in. wg. To calculate velocity pressure ( $V_p$ ) in the duct, use the following formula, where  $V$  is the air velocity in the duct:

$$V_p = [(V) \div (4005)]^2$$

Also note that with more than one duct takeoff and different duct velocities, the highest duct velocity and highest  $C_v$  value should be used in the formulas.

## Duct design considerations

The discharge ductwork immediately downstream from the fan is critical for successful applications. Poorly designed ductwork can degrade fan performance and contributes to excessive pressure drop and noise.

The 39S Series forward-curved fans are tested as part of a system with straight discharge ductwork, and the fan ratings are based on this duct design. When designing ductwork in the field, it is important to use a straight discharge duct of the correct dimensions to obtain maximum fan performance. The straight section of ductwork helps the airflow to develop a uniform velocity profile as it exits the fan and allows the velocity pressure to recover into static pressure. See the figure on the next page.

For 100% recovery of velocity pressure into static pressure, the straight portion of the discharge duct must be at least  $2^{1/2}$  times the discharge diameter in length for



velocities of 2500 fpm or less. For each additional 1000 fpm, add one duct diameter to the length of the straight portion of the ductwork.

As an example of how to size the straight portion of duct, assume the fan has a 34 x 34 in. discharge outlet (8.03 sq ft). The equivalent diameter is 39 in., so the straight duct length required would be 8 ft long.

Plenum fans do not require belts in the system. Therefore, users can expect improved efficiency.

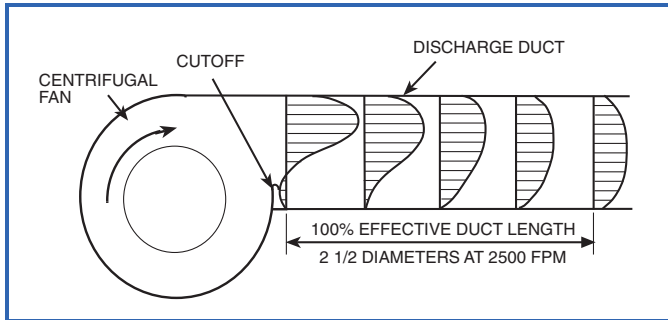

## Fan control on variable air volume systems

### Introduction

With their inherent characteristics of reducing airflow to meet demand, VAV systems can be a source of major energy savings, because fan brake horsepower (bhp) varies with the amount of air delivered.

The degree to which bhp savings are realized, however, is also affected by the type of fan volume control selected and the effectiveness of its application. Effective fan control assures proper duct pressure for the required control stability of the air terminals and provides quiet terminal unit operation when “riding the fan curve.”

Consider the following when selecting a fan volume control method:

1. System parameters
  - a. Airflow (cfm)
  - b. Static pressure
  - c. Percent volume reduction (turndown)
2. Fan type and selection point
  - a. Design point efficiency
  - b. Part load efficiency (especially the point where the fan will be operating most of the time)
  - c. Part load stability
3. Ease of control installation and use
4. Motor selection
  - a. Higher bhp inputs due to efficiency of VAV control method
  - b. Compatibility with VAV control
5. Sound levels
  - a. Fan-generated sound
  - b. Terminal sound
  - c. Control-generated sound
  - d. System sound (ducts, fittings)
6. Initial cost and operating cost
7. Reliability and ease of maintenance

## System parameters

Before a fan type or control is selected, the system must be analyzed at both the design point and part load. The fan is likely to be operating at part load for a large percentage of the time.

## Methods of fan air-volume control

- “Riding the fan curve” with terminal throttling (forward curved fans)
- Variable frequency drives (VFDs)

A short description of these control methods follows. A summary comparison table is provided at the end of the section.

**Forward-curved (FC) fans with terminal throttling (riding fan curve)** — This is the simplest, most reliable, and most economical first-cost method of air volume control on VAV systems, since no accessories are required. This type of VAV control can be used on forward-curved fans with flat pressure characteristics and in systems where static pressure changes at the terminals are moderate. Air volume reduction is produced solely by throttling of terminal units in response to load reduction. As the units throttle, system resistance changes.

The chart below, Forward-Curved Fan with Air Terminal Throttling, illustrates the reduction in bhp and airflow at constant speed. Point A is the peak airflow operating point. Note the required bhp at this airflow. As airflow is reduced by terminal throttling, move along the fan constant rpm curve to point B. Note the lower cfm and bhp values at B.

At reduced airflow conditions, the total system static pressure may undergo little or no change, although air pressure loss through the air-handling unit decreases. This means that duct pressure increases as pressure loss across the terminal unit increases. For low-static and medium-static pressure systems, this increase in duct pressure should not result in noticeable sound level changes. However, at higher design static pressures, sound levels and duct leakage may increase and the control method should be reviewed to determine if it is feasible.

## FAN TYPE AND APPLICATION

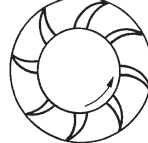
TYPE	CHARACTERISTICS	APPLICATION
<b>Forward-Curved (FC) Side View</b> 	<ul style="list-style-type: none"> <li>• Double-width, double-inlet (DWDI) construction.</li> <li>• Best at low or medium pressure (approximately 0 to 5 in. wg).</li> <li>• Horsepower increases continuously with increase in air quantity (overloads) as static pressure decreases.</li> <li>• Runs at relatively low speed, typically 400 to 1200 rpm.</li> <li>• Blades curve toward direction of rotation.</li> </ul>	For low to medium pressure air-handling applications.
<b>Plenum (PAF) End View</b> 	<ul style="list-style-type: none"> <li>• Single-width, single-inlet (SWSI) construction.</li> <li>• Characteristics similar to DWDI airfoil fan.</li> <li>• Blades have aerodynamic shape similar to airplane wing and are curved away from direction of rotation. Fewer blades and wider blade spacing than AF fans.</li> </ul>	Best in applications with limited space or multiple ducts.

### FORWARD-CURVED FAN WITH AIR TERMINAL THROTTLING VARIATIONS IN BHP AT CONSTANT RPM

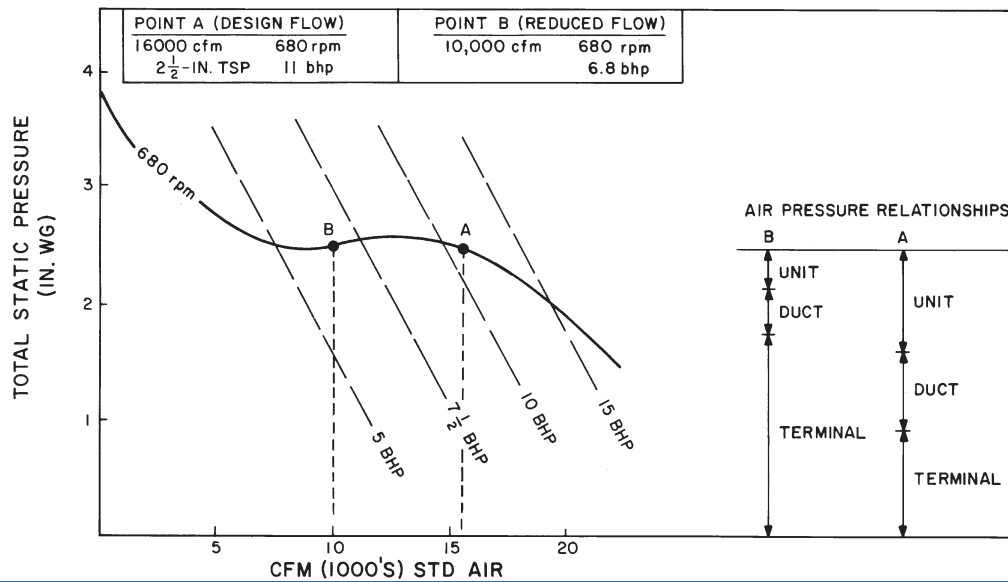

**Variable frequency drives** — Variable frequency drives (VFDs) are used to modulate the fan motor speed in response to air volume requirements. To vary the motor speed, a VFD changes the input frequency and line voltage into a wide range of frequency and voltage outputs, while maintaining a constant ratio of frequency to voltage.

Variable frequency drives convert input ac power to dc power and then convert the dc power to a different ac power output using an inverter. The inverter creates the ac output by rapidly switching the polarity of the voltage from positive to negative. Power output from the VFD is not a smooth sine wave, but has many “steps” in the wave form. This type of power output can cause a standard fan motor to exceed its rated temperature range. The stepped power output also results in motor efficiency losses that must be considered when calculating the energy savings offered by the VFD.

Because of the stepped power output generated by VFDs, fan motors rated for inverter duty are recommended. If a standard motor is used with a VFD, the motor should not be operated at the full service factor.

Variable frequency drives can be an effective way to control air volume and save energy. They can provide greater reduction in fan bhp than throttling with either fan discharge dampers or inlet guide vanes. At reduced load requirements, fan speed is reduced proportionately, with resulting lower airflow, lower static pressure, lower bhp requirements, and lower sound levels.

As the load decreases in a VAV system and the terminal units throttle, duct static pressure increases. A static pressure sensor in the duct system detects the pressure increase and initiates a fan speed change through the VFD. Fan speed is reduced until the duct sensor detects a satisfactory duct pressure.

The Variable Frequency Fan Speed Control chart illustrates the results of fan speed reduction as operation shifts from Point A to Point B. If duct pressure begins to fall due to terminal units opening, the duct sensor signals the VFD to increase fan speed.

This method of air volume control permits fan speed reduction down to as low as 10% of the design speed. With FC fans riding the fan curve at the lower rpm, airflow may be as low as 10% of peak design, **as long as motor rpm is not less than 1/6 of motor synchronous speed.**

The method may be applied to any size VAV system with any type of fan. It is particularly cost effective on systems with high turndown requirements where the full speed reduction capability can be used.

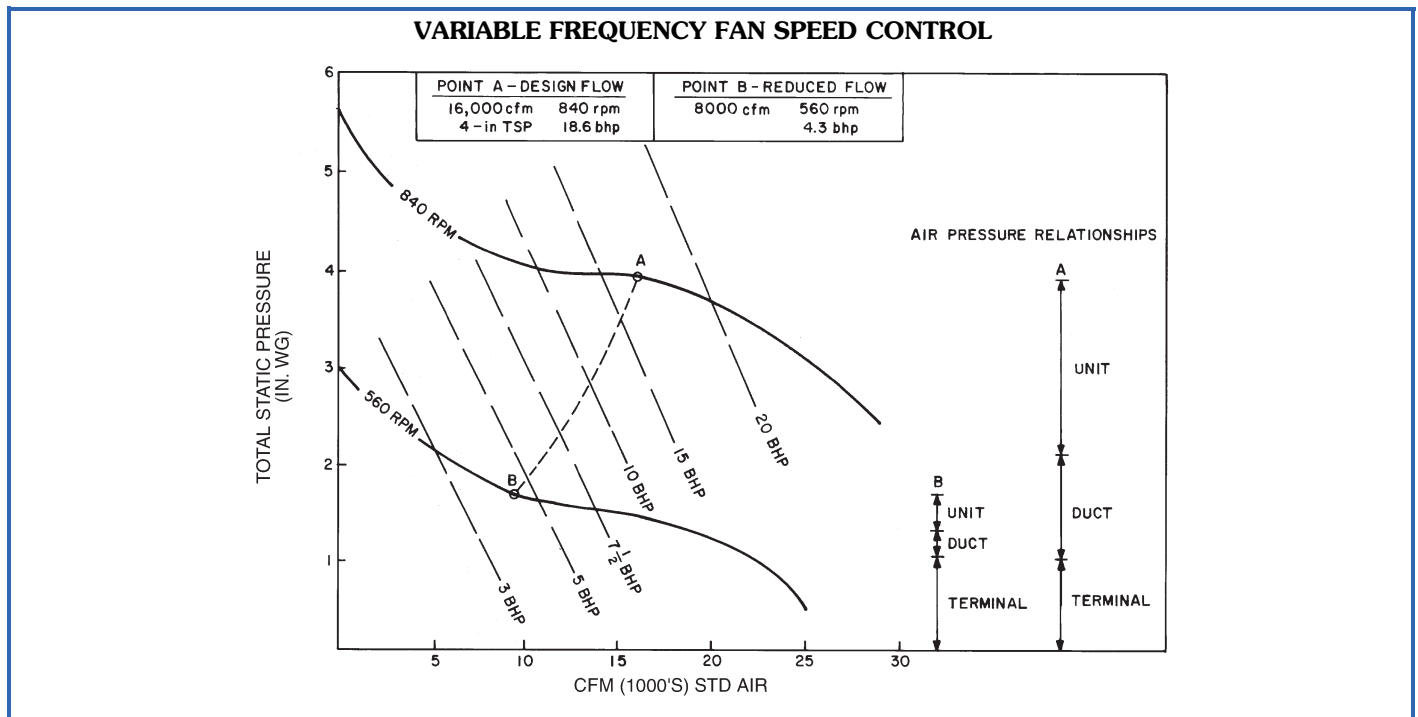

## FAN SUMMARY COMPARISON

TYPE OF CONTROL	FIRST-COST RANK	TURNDOWN RANGE (Normal)*	SOUND GENERATION RANK†	ENERGY-SAVINGS RANK	APPLICATION RANGE — NORMAL FOR AIR COND.	COMMENTS
FC Fan Terminal Throttling (Riding Fan Curve)	1 (Lowest Cost)	60-70%	3	3	TSP 0" to 4.5" Cfm 3,000 to 15,000	For moderate turndown systems with a flat fan curve and low to medium static pressure and cfm range.
FC Fan with 2-Speed Motor	3	(Not Applicable)	2	2	TSP 0" to 4.5" Cfm 3,000 to 15,000	For systems with predictable 2-load situations in low to medium static pressure range. Controls are more complicated. Starters are more costly.
FC Fan With Variable Frequency Drive	2	10-15%	1 (Quietest)	1 (Best)	TSP 0" to 4.5" Cfm 3,000 to 15,000	For high turndown, low to medium static pressure systems. Best energy savings. Fast payback. Fan generates least sound.

### LEGEND

FC — Forward Curved  
TSP — Total Static Pressure

\*Percentage of modulation of the design airflow.

†Including part load.

NOTE: Rank is based on a relative scale of 1 to 4. Some methods have comparable rating.

## Unit control arrangements with Direct Digital Controls

### Supply fan control

Supply fan control is used to match the supply fan delivery to the airflow required by the load in a variable air volume system. This is done by maintaining a constant static pressure in the supply duct at a point approximately  $\frac{2}{3}$  of the distance from the supply fan discharge.

The microprocessor uses a control loop to provide the capability. This processor measures the static pressure at the pick-up probe, compares it to the desired set point, and modulates the fan volume control device. See the Supply Fan Control figure. The volume control device can be a factory-installed or field-installed variable frequency drive (VFD).

Inlet guide vanes are not offered on 39S units. For supply fan control, it is recommended that a VFD be used. The VFD offers several advantages over inlet guide vanes. First, the VFD operates more efficiently in most applications, thus saving energy. The VFD also provides the ability to maintain control over a much larger airflow range (it has a higher turn-down ratio).

The following guideline should be used to ensure proper control:

Variable frequency drives should not be operated at below 10% of the maximum for which the fan was selected, regardless of the fan type.

For supply fan applications, the microprocessor option maintains the duct static pressure at a desired set point between 0.2 and 4.5 in. wg to within  $\pm 0.1$  in. wg throughout the fan control range. In applications where over 100 ft of pneumatic tubing is required, the transducer must be removed from the control box and remotely mounted near the static pressure pickup.

### Indoor air quality (IAQ) applications

The CO<sub>2</sub> demand-controlled ventilation override increases the minimum ventilation level in order to maintain the CO<sub>2</sub> level at or below the maximum level per person. Features include the ability to save energy by ventilating only to the actual rate required, rather than the maximum design occupancy rate. When combined with Product Integrated Controls, the feature automatically adapts and changes ventilation quantity without operator set point adjustments. The feature has user-selectable values for minimum mixed-air temperature override, maximum damper ventilation override position, and supply air tempering (when hot water/steam heat is used).

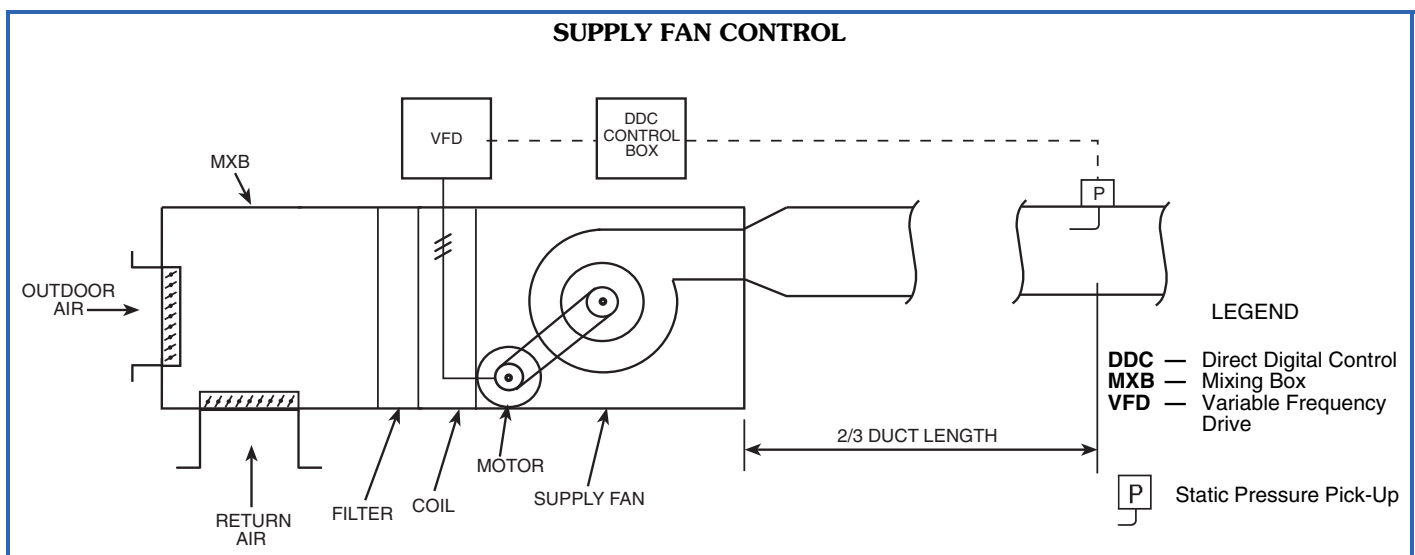

## Coils

### Coil definitions

A coil, as the term is used with air-handling equipment, is a heat exchange device. A heating or cooling medium passes through the coil, where it either rejects heat to or absorbs heat from the airstream passing over the coil, depending upon the relative temperatures of medium and airstream.

**Tube** — The tube is a small-diameter pipe through which the heating or cooling medium passes as it rejects or absorbs heat. Coil tubes are generally constructed of copper but may be made of other metals.

**Fin** — The coil fin is a thin metal plate attached to the tube to improve the heat transfer efficiency from medium to airstream. Typically, it is made of either aluminum or copper.

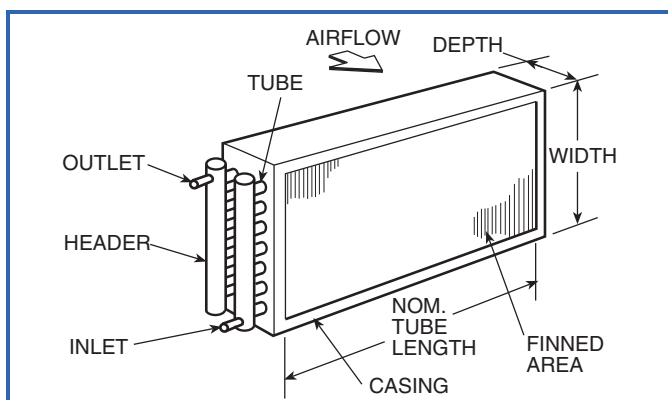

**Header** — The header is a pipe of large diameter to which several tubes are connected. It serves as a distributor of the heating or cooling medium to the tubes. Headers are typically of non-ferrous metal or steel.

**Casing** — The supporting metal structure for tubes and header is called a casing. It is usually made of galvanized steel but can be made of other materials (stainless steel).

**Inlet and outlet** — These are pipe stubs on the header where the heating or cooling medium enters and leaves the coil.

In water coils, the supply inlet is the pipe stub located on the side where the air leaves the coil. The outlet is the stub on the entering air side of the coil. Such an arrangement is known as counterflow.

In steam coils, the inlet is always the higher stub so that condensate will drain out of the lower stub.

**Finned area or face area** — The working area of the coil is defined as the width times length of the finned area through which air passes. This finned or face area does not include the extra dimensions for the casing.

**Face velocity** — This is the air velocity in fpm across the finned or face area of a coil. It is determined by dividing the air volume in cfm by the coil face area in square feet.

$$\text{Face Velocity (fpm)} = \frac{\text{Air Volume (cfm)}}{\text{Coil Face Area (sq ft)}}$$

The first step in selecting an air handler size is to determine the maximum allowable face velocity.

This maximum is determined by the specifier and is based primarily on the following criteria:

1. Avoidance of moisture carryover into the ductwork (applies to cooling coils only).
2. Air pressure drop across the coil.
3. Heat transfer efficiency.

The maximum safe air velocity without moisture carryover into the ductwork depends on the type and spacing of the finned surface, the amount of moisture on the coil, and the geometry between coil and fan inlet or ductwork. Since coil moisture conditions vary, and coil versus duct geometry varies (for example, between draw-thru, blow-thru, vertical, or horizontal units), the specified maximum face velocity should allow for these variations.

Fan horsepower is also affected by face velocity, since the air resistance across the coil varies roughly as the square of the face velocity.

For the above reasons, the maximum specified face velocity is normally a conservative figure (on the low side). Suggested design face velocities are as follows:

COIL TYPE	FACE VELOCITY RANGE
Cooling	400 to 525 fpm
Heating	400 to 800 fpm

In variable air volume (VAV) applications, the system generally operates below peak air volume for extended periods. In such cases, the design face velocity is commonly selected at the higher end of the suggested range.

**Tube face** — The number of tubes in any one coil row.

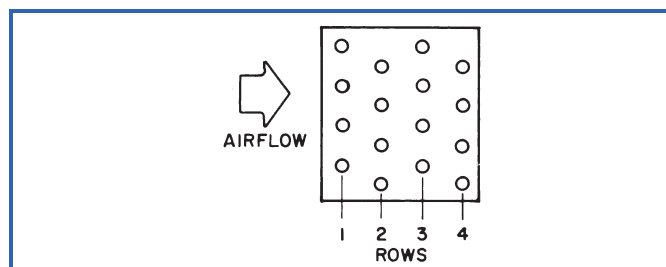

Above is a 4-row coil with a 4-tube face. Note that tubes are staggered in adjacent rows.

Cooling coils are typically available in 4 and 6-row configurations. Coils should be sized for the most efficient use of water. Water temperature differences of 12 to 16° F are typical and represent optimum selection points.

**Direct expansion (DX) coils** — Direct expansion coils can have two intertwined refrigerant circuits. In addition, quarter, half, full and double circuiting configurations are offered to allow optimum system performance and oil return at full and part load operation.

Circuiting selection should result in a circuit loading of 0.8 to 2.0 tons per circuit at design load. Circuit loading must be evaluated at minimum load to ensure that it does not drop below 0.6 tons per circuit. Solenoid valves may be used, if necessary, to shut off the refrigerant supply to individual expansion valves to maintain adequate coil circuit loading.



# Application data (cont)



Compressor minimum unloading and TXV quantity is necessary to determine minimum tonnage per circuit.

Minimum Unloading Equation:

$$\frac{(Tons/Circuit) \times (Minimum Unloading) \times (Total \# \text{ of TXVs})}{\# \text{ of TXVs Active}}$$

Example:

Condensing Unit: 38AUZ012  
Minimum Unloading: 33%  
Coil: 6 row, 11 FPI, Half Circuit  
Coil Tons/Circuit: 1.68  
Total TXVs: 2

In the first example we will determine the tons/circuit when both TXVs are active and the compressor is unloaded to its minimum of 33%.

$$= \frac{(1.68 \text{ Tons/Circuit}) \times (33\% \text{ Minimum Unloading}) \times (2 \text{ TXVs})}{2 \text{ TXVs Active}}$$

$$= \frac{(1.68) \times (.33) \times (2)}{2}$$

= .55 tons/circuit at minimum unloading: UNACCEPTABLE

If we install a liquid line solenoid valve before one of the TXVs and close it so that only one TXV is active when the compressor is unloaded to its minimum of 33 %, we see the following:

$$= \frac{(1.68 \text{ Tons/Circuit}) \times (33\% \text{ Minimum Unloading}) \times (2 \text{ TXVs})}{1 \text{ TXV Active}}$$

$$= \frac{(1.68) \times (.33) \times (2)}{1}$$

= 1.10 tons/circuit at minimum unloading: ACCEPTABLE

Thermostatic expansion valve (TXV) kits are available through **AHUBuilder**® software. If TXVs are purchased from an alternate vendor, be sure to specify a 5% minimum bleed port.

## Filters

Air is contaminated in varying degrees by soil, organic matter, spores, bacteria, smoke, dust, and fumes.

Air cleaning and filtration devices are required in order to create a clean work environment, reduce cleaning costs, and extend the life of machinery or equipment.

## Filter ratings (MERV)

Filters are rated according to efficiency and dust-holding capacity.

The most commonly accepted method of testing filter efficiency is per ASHRAE (American Society of Heating, Refrigerating and Air-Conditioning Engineers) Standard 52. An explanation of filter ratings can be found in Chapter 24 of the ASHRAE HVAC Systems and Equipment Handbook. ASHRAE standard 52.2 defines the minimum efficiency reporting value (MERV).

Filter dust-holding capacity is directly related to filter life. The filter is replaced when the amount of dirt and dust it contains builds up air resistance to an unacceptable level. Air resistance build-up is measured by a filter air-resistance gage.

# Selection procedure



## Size selection

This catalog has been designed to provide a quick and accurate means of selecting and specifying a central station air-handling unit. Start with the information you have, required airflow and preferred coil face velocity, to select a nominal unit size. Contact your Carrier sales representative for the **AHUBuilder**® program. Next, refer to the component descriptions on pages 31-50. After determining the unit size and unit configuration, use the worksheet on this page to record dimension and weight information for each section and to add the total unit weight and length.

NOTE: The **AHUBuilder** program provides coil and fan performance data designed to comply with AHRI 410 and 430 standards.

## Cost-efficient, computerized selection

The Products and Systems Electronic Catalog is a series of computer programs designed to run on a personal computer to select products and systems offered by Carrier.

### AHUBuilder program general features:

- Provides “true” selection for all air-handling units coils and fans. Required capacity and/or entering and leaving conditions may be specified with the program determining performance ratings for all applicable coil configurations. User-specified performance rating for a particular configuration or for specified performance criteria
- Minimized specifying input criteria — fixed or rarely changing parameters user specified as defaults and separated from main input screen
- Displayed output mode of coil performance ratings allow side-by-side comparison of user-defined performance ratings values (4 calculated values for each coil), or complete performance ratings of all coils in a spreadsheet format
- Detailed summary reports including cooling, heating, fan, and physical performance data can be generated in different formats. Fully featured on-line help system contained within the program
- Easier to use than previous generation systems

**AHUBuilder program special features** — The program allows the user to continually monitor and modify input/output and provides processing for special application such as altitude.

## SPECIFICATION WORKSHEET

JOB NAME \_\_\_\_\_

MARK FOR \_\_\_\_\_

CAPACITY \_\_\_\_\_ CFM \_\_\_\_\_

STATIC PRESSURE (in. wg)  
 Internal \_\_\_\_\_ External \_\_\_\_\_ Total \_\_\_\_\_

RPM \_\_\_\_\_ BHP \_\_\_\_\_ CYCLES \_\_\_\_\_

MTR TYPE \_\_\_\_\_

PIPE CONNECTION SIZES  
 COOLING COIL: SUPPLY \_\_\_\_\_ RETURN \_\_\_\_\_  
 HEATING COIL: SUPPLY \_\_\_\_\_ RETURN \_\_\_\_\_

FILTERS  
 SIZE \_\_\_\_\_ QTY \_\_\_\_\_  
 SIZE \_\_\_\_\_ QTY \_\_\_\_\_

COMPONENT SEQUENCE	LENGTH	WEIGHT
_____	+ _____	_____
_____	+ _____	_____
_____	+ _____	_____
_____	+ _____	_____
_____	+ _____	_____
_____	+ _____	_____
_____	+ _____	_____
_____	+ _____	_____
_____	+ _____	_____
_____	+ _____	_____
MOTOR _____	+ _____	_____
COIL _____	+ _____	_____
TOTAL	_____	_____

COMMENTS: \_\_\_\_\_  
 \_\_\_\_\_  
 \_\_\_\_\_

PREPARED BY: \_\_\_\_\_

DATE: \_\_\_\_\_

# Selection procedure (cont)



## Electric heat selection procedure

### I Determine electric heat requirements based on size of selected unit.

Given:

Air Quantity . . . . . 3,000 cfm  
Entering-Air Temperature . . . . . 54 F  
Leaving-Air Temperature . . . . . 77 F  
Maximum Air Velocity . . . . . 650 fpm  
Electric Service . . . . . 460-v, 3-ph, 60-Hz  
Unit Type . . . . . Horizontal Draw-Thru

### II Determine heating load.

$$\begin{aligned} \text{Heating Load} &= 1.1 \times \text{Cfm} \times \text{Air Temp Rise} \\ &= 1.1 \times 3,000 \times 23 \\ &= 75,900 \text{ Btuh (75.9 MBtuh)} \end{aligned}$$

### III Verify unit size.

Size of the electric heating coil face area is usually predetermined by the selection of the air-handling unit and the cooling coil. However, the heater size must be checked to assure that the minimum face velocity is provided for the heater.

$$\begin{aligned} \text{Minimum Face Area} &= \frac{3,000}{650 \text{ fpm}} \\ &= 4.6 \text{ sq ft} \end{aligned}$$

$$\begin{aligned} \text{Actual Face Velocity} &= \frac{3,000}{4.9 \text{ sq ft}} \quad (\text{Actual Coil Face Area}) \\ &= 615 \text{ fpm} \end{aligned}$$

### IV Determine kilowatt equivalent of heating load.

$$\begin{aligned} \text{kW Heating Load} &= \frac{75.9 \text{ MBtuh}}{3.413 \text{ MBtuh/kW}} \\ &= \frac{75.9}{3.413} \\ &= 22.2 \text{ kW} \end{aligned}$$

### V Determine unit electric heater size.

Select the heater which has a kW rating closest to but greater than the required kW and is available at the required voltage.

### VI Determine capacity of electric heater.

$$\begin{aligned} \text{Capacity} &= 23 \text{ kW} \times 3.413 \\ &= 78.5 \text{ MBtuh} \end{aligned}$$

### VII Calculate air temperature rise.

$$\begin{aligned} \text{Air Temp Rise} &= \frac{78,500 \text{ Btuh}}{1.1 \times 3,000 \text{ Cfm}} \\ &= 23.8 \text{ F} \end{aligned}$$

### VIII Calculate the actual leaving-air temperature.

$$\begin{aligned} \text{Leaving Air Temp} &= \text{Ent Air Temp} + \text{Air Temp Rise} \\ &= 54 + 23.8 \\ &= 77.8 \text{ F} \end{aligned}$$

### IX Voltage variations.

Variations from the rated voltage of the electric heating coils can significantly affect the coil's rated output. The effects of voltage variation can be determined by the following formula.

$$\text{kW}_a = \text{kW}_r \times \left( \frac{V_a}{V_r} \right)^2$$

$\text{kW}_a$  = Actual kW Output From Coil  
 $\text{kW}_r$  = Rated kW Output From Coil  
 $V_a$  = Actual Voltage at Coil  
 $V_r$  = Rated Voltage at Coil

### Air-handling selection guide

1. Unit size = Coil face area (ft<sup>2</sup>) = design cfm/max face velocity  
Example: 4,000 cfm/500 fpm = 8 → Size 09
2. Consider your system and choose the appropriate component sections.
3. Determine overall unit dimensions and weight. The height and width for any given unit size is the same for all component sections.
4. Finalize your selections using the latest version of the **AHUBuilder**® program. The **AHUBuilder** program is a comprehensive selection tool designed to help customers make the proper air handler choice quickly and efficiently.

# Performance data



Refer to the **AHUBuilder** program for 39S unit performance data.

## ELECTRIC HEATER DATA

### 39SHK SINGLE PHASE

39SHK UNIT SIZE	HEATER AREA (sq ft)	HEATER COIL (kW)	NOMINAL COIL FACE VELOCITY (fpm)	TEMP RISE (°F)	240-1-60 (V-Ph-Hz)					277-1-60 (V-Ph-Hz)					
					TOTAL FLA	MCA*	NO. SUB CKT	MOCP	NO. CONTROL STEPS	TOTAL FLA	MCA*	NO. SUB CKT	MOCP	NO. CONTROL STEPS	
00	0.63	0.8	700	6	3	4	1	15	1	—	—	—	—	—	
		1.0	700	7	4	5	1	15	1	4	5	1	15	1	
		1.5	700	11	6	6	8	1	15	1	—	—	—	—	—
		2.0	700	15	8	8	10	1	15	1	7	9	1	15	1
		2.3	700	17	10	12	1	15	1	—	—	—	—	—	—
		3.0	700	22	13	16	1	20	1	11	14	1	15	1	1
01	0.63	4.0	700	29	17	21	1	25	1	14	18	1	20	1	
		0.8	1000	4	3	4	1	15	1	—	—	—	—	—	
		1.0	1000	5	4	5	1	15	1	4	5	1	15	1	
		1.5	1000	8	6	8	1	15	1	—	—	—	—	—	
		2.0	1000	10	8	10	1	15	1	7	9	1	15	1	
		2.3	1000	12	10	12	1	15	1	—	—	—	—	—	
		3.0	1000	15	13	16	1	20	1	11	14	1	15	1	
		3.8	1000	19	16	20	1	20	1	—	—	—	—	—	
		4.0	1000	20	17	21	1	25	1	14	18	1	20	1	
02	0.61	4.5	1000	23	19	23	1	25	1	—	—	—	—	—	
		5.0	1000	25	21	26	1	30	1	18	23	1	25	1	
		6.0	1000	31	25	31	1	35	1	22	27	1	30	1	
		3.8	1400	14	16	20	1	20	1	—	—	—	—	—	
		4.5	1400	17	19	23	1	25	1	—	—	—	—	—	
		5.0	1400	19	21	26	1	30	1	18	23	1	25	1	
		5.3	1400	20	22	28	1	30	1	—	—	—	—	—	
		6.0	1400	22	25	31	1	35	1	22	27	1	30	1	
		6.8	1400	25	28	35	1	40	2	—	—	—	—	—	
		7.0	1400	26	29	36	1	40	2	25	32	1	35	2	
03	0.61	7.5	1400	28	31	39	1	40	2	—	—	—	—	—	
		8.0	1400	30	33	42	1	45	2	29	36	1	40	2	
		9.0	1400	33	38	47	1	50	2	32	41	1	45	2	
		10.0	1400	37	42	52	1	60	2	36	45	1	50	2	
		3.8	2000	10	16	20	1	20	1	—	—	—	—	—	
		4.5	2000	12	19	23	1	25	1	—	—	—	—	—	
		5.0	2000	13	21	26	1	30	1	18	23	1	25	1	
		5.3	2000	14	22	28	1	30	1	—	—	—	—	—	
		6.0	2000	16	25	31	1	35	1	22	27	1	30	1	
		6.8	2000	18	28	35	1	40	2	—	—	—	—	—	
7.0	2000	18	29	36	1	40	2	25	32	1	35	2			
7.5	2000	19	31	39	1	40	2	—	—	—	—	—			
8.0	2000	21	33	42	1	45	2	29	36	1	40	2			
9.0	2000	23	38	47	1	50	2	32	41	1	45	2			
10.0	2000	26	42	52	1	60	2	36	45	1	50	2			

#### LEGEND

- AHRI — Air-Conditioning, Heating and Refrigeration Institute
- CKT — Circuit
- FLA — Full Load Amps
- MCA — Maximum Circuit Amps
- MOCP — Maximum Overcurrent Protection

\*MCA = 1.25 x FLA. For proper wiring size, refer to Table 310-16 of the NEC (National Electrical Code).

#### NOTES:

1. Subcircuits are internal heater circuits of 48 amps or less.
2. Electric heat performance is not within the scope of AHRI standard 430 certification.
3. To avoid damage due to overheating, minimum face velocity cannot fall below 350 fpm.
4. Single phase heaters 6 kW and below have 1 control step; all others have 2 controls steps as standard.
5. Heater kW offering is controlled by the **AHUBuilder**® program. This table for reference only.
6. A 240-v rated heater with 230-v supply shall be derated 8%.
7. A 240-v rated heater with 208-v supply shall be derated 25%.

## ELECTRIC HEATER DATA (cont)

### 39SHK SINGLE PHASE (cont)

39SHK UNIT SIZE	HEATER AREA (sq ft)	HEATER COIL (kW)	NOMINAL COIL FACE VELOCITY (fpm)	TEMP RISE (°F)	240-1-60 (V-Ph-Hz)					277-1-60 (V-Ph-Hz)				
					TOTAL FLA	MCA*	NO. SUB CKT	MOCP	NO. CONTROL STEPS	TOTAL FLA	MCA*	NO. SUB CKT	MOCP	NO. CONTROL STEPS
04	0.87	3.8	1900	7	16	20	1	20	1	—	—	—	—	—
		4.5	1900	9	19	23	1	25	1	—	—	—	—	—
		5.0	1900	10	21	26	1	30	1	18	23	1	25	1
		5.3	1900	10	22	28	1	30	1	—	—	—	—	—
		6.0	1900	12	25	31	1	35	1	22	27	1	30	1
		6.8	1900	13	28	35	1	40	2	—	—	—	—	—
		7.0	1900	14	29	36	1	40	2	25	32	1	35	2
		7.5	1900	14	31	39	1	40	2	—	—	—	—	—
		8.0	1900	15	33	42	1	45	2	29	36	1	40	2
		8.3	1900	16	35	43	1	45	2	—	—	—	—	—
		9.0	1900	17	38	47	1	50	2	32	41	1	45	2
		9.8	1900	19	41	51	1	60	2	—	—	—	—	—
		10.0	1900	19	42	52	1	60	2	36	45	1	50	2
		10.5	1900	20	44	55	1	60	2	—	—	—	—	—
		11.0	1900	21	46	57	1	60	2	40	50	1	50	2
		11.3	1900	22	47	59	1	60	2	—	—	—	—	—
		12.0	1900	23	50	63	2	70	2	—	—	—	—	—
		12.8	1900	25	53	67	2	70	2	—	—	—	—	—
13.0	1900	25	54	68	2	70	2	—	—	—	—	—		
14.0	1900	27	58	73	2	80	2	—	—	—	—	—		
15.0	1900	29	63	78	2	80	2	—	—	—	—	—		
16.0	1900	31	67	83	2	90	2	—	—	—	—	—		
17.0	1900	33	71	89	2	90	2	—	—	—	—	—		
05	1.20	7.5	1700	12	31	39	1	40	2	—	—	—	—	—
		8.0	1700	13	—	—	—	—	—	—	—	—	—	—
		8.3	1700	13	35	43	1	45	2	—	—	—	—	—
		9.0	1700	14	38	47	1	50	2	—	—	—	—	—
		9.8	1700	15	41	51	1	60	2	—	—	—	—	—
		10.0	1700	16	42	52	1	60	2	36	45	1	50	2
		10.5	1700	16	44	55	1	60	2	—	—	—	—	—
		11.0	1700	17	46	57	1	60	2	40	50	1	50	2
		11.3	1700	18	47	59	1	60	2	—	—	—	—	—
		12.0	1700	19	50	63	2	70	2	—	—	—	—	—
		12.8	1700	20	53	67	2	70	2	—	—	—	—	—
		13.0	1700	20	54	68	2	70	2	—	—	—	—	—
		13.5	1700	21	56	70	2	80	2	—	—	—	—	—
		14.0	1700	22	58	73	2	80	2	—	—	—	—	—
		14.3	1700	22	60	74	2	80	2	—	—	—	—	—
15.0	1700	23	63	78	2	80	2	—	—	—	—	—		
16.0	1700	25	67	83	2	90	2	—	—	—	—	—		
17.0	1700	27	71	89	2	90	2	—	—	—	—	—		
18.0	1700	28	75	94	2	100	2	—	—	—	—	—		
19.0	1700	30	79	99	2	100	2	—	—	—	—	—		

#### LEGEND

- AHRI — Air-Conditioning, Heating and Refrigeration Institute
- CKT — Circuit
- FLA — Full Load Amps
- MCA — Maximum Circuit Amps
- MOCP — Maximum Overcurrent Protection

\*MCA = 1.25 x FLA. For proper wiring size, refer to Table 310-16 of the NEC (National Electrical Code).

#### NOTES:

1. Subcircuits are internal heater circuits of 48 amps or less.
2. Electric heat performance is not within the scope of AHRI standard 430 certification.
3. To avoid damage due to overheating, minimum face velocity cannot fall below 350 fpm.
4. Single phase heaters 6 kW and below have 1 control step; all others have 2 controls steps as standard.
5. Heater kW offering is controlled by the AHUBuilder® program. This table for reference only.
6. A 240-v rated heater with 230-v supply shall be derated 8%.
7. A 240-v rated heater with 208-v supply shall be derated 25%.



**ELECTRIC HEATER DATA (cont)**

**39SHK SINGLE PHASE (cont)**

39SHK UNIT SIZE	HEATER AREA (sq ft)	HEATER COIL (kW)	NOMINAL COIL FACE VELOCITY (fpm)	TEMP RISE (°F)	240-1-60 (V-Ph-Hz)					277-1-60 (V-Ph-Hz)				
					TOTAL FLA	MCA*	NO. SUB CKT	MOCP	NO. CONTROL STEPS	TOTAL FLA	MCA*	NO. SUB CKT	MOCP	NO. CONTROL STEPS
07	1.50	9.0	2000	10	38	47	1	50	2	—	—	—	—	—
		9.8	2000	10	41	51	1	60	2	—	—	—	—	—
		10.0	2000	11	—	—	—	—	—	—	—	—	—	—
		10.5	2000	11	44	55	1	60	2	—	—	—	—	—
		11.0	2000	12	—	—	—	—	—	—	—	—	—	—
		11.3	2000	12	47	59	1	60	2	—	—	—	—	—
		12.0	2000	13	50	63	2	70	2	—	—	—	—	—
		12.8	2000	14	53	67	2	70	2	—	—	—	—	—
		13.0	2000	14	54	68	2	70	2	—	—	—	—	—
		13.5	2000	14	56	70	2	80	2	—	—	—	—	—
		14.0	2000	15	58	73	2	80	2	—	—	—	—	—
		14.3	2000	15	60	74	2	80	2	—	—	—	—	—
		15.0	2000	16	63	78	2	80	2	—	—	—	—	—
		15.8	2000	17	66	82	2	90	2	—	—	—	—	—
		16.0	2000	17	67	83	2	90	2	—	—	—	—	—
		17.0	2000	18	71	89	2	90	2	—	—	—	—	—
18.0	2000	19	75	94	2	100	2	—	—	—	—	—		
19.0	2000	20	79	99	2	100	2	—	—	—	—	—		
20.0	2000	21	83	104	2	110	2	—	—	—	—	—		
21.0	2000	22	88	109	2	110	2	—	—	—	—	—		
09	1.50	10.0	2700	8	—	—	—	—	—	—	—	—	—	—
		11.0	2700	9	—	—	—	—	—	—	—	—	—	—
		12.0	2700	9	—	—	—	—	—	—	—	—	—	—
		12.8	2700	10	53	67	2	70	2	—	—	—	—	—
		13.0	2700	10	—	—	—	—	—	—	—	—	—	—
		13.5	2700	11	56	70	2	80	2	—	—	—	—	—
		14.0	2700	11	—	—	—	—	—	—	—	—	—	—
		14.3	2700	11	60	74	2	80	2	—	—	—	—	—
		15.0	2700	12	63	78	2	80	2	—	—	—	—	—
		15.8	2700	12	66	82	2	80	2	—	—	—	—	—
		16.0	2700	13	—	—	—	—	—	—	—	—	—	—
		17.0	2700	13	71	89	2	90	2	—	—	—	—	—
		18.0	2700	14	75	94	2	100	2	—	—	—	—	—
19.0	2700	15	79	99	2	100	2	—	—	—	—	—		
20.0	2700	16	83	104	2	110	2	—	—	—	—	—		
21.0	2700	17	88	109	2	110	2	—	—	—	—	—		

**LEGEND**

- AHRI** — Air-Conditioning, Heating and Refrigeration Institute
- CKT** — Circuit
- FLA** — Full Load Amps
- MCA** — Maximum Circuit Amps
- MOCP** — Maximum Overcurrent Protection

\*MCA = 1.25 x FLA. For proper wiring size, refer to Table 310-16 of the NEC (National Electrical Code).

**NOTES:**

1. Subcircuits are internal heater circuits of 48 amps or less.
2. Electric heat performance is not within the scope of AHRI standard 430 certification.
3. To avoid damage due to overheating, minimum face velocity cannot fall below 350 fpm.
4. Single phase heaters 6 kW and below have 1 control step; all others have 2 controls steps as standard.
5. Heater kW offering is controlled by the **AHUBuilder®** program. This table for reference only.
6. A 240-v rated heater with 230-v supply shall be derated 8%.
7. A 240-v rated heater with 208-v supply shall be derated 25%.

## ELECTRIC HEATER DATA (cont)

### 39SHK 3 PHASE

39SHK UNIT SIZE	HEATER AREA (sq ft)	HEATER COIL (kW)	NOMINAL COIL FACE VELOCITY (fpm)	TEMP RISE (°F)	240-3-60 (V-Ph-Hz)					480-3-60 (V-Ph-Hz)				
					TOTAL FLA	MCA*	NO. SUB CKT	MOCP	NO. CONTROL STEPS	TOTAL FLA	MCA*	NO. SUB CKT	MOCP	NO. CONTROL STEPS
00	0.63	0.8	700	6	2	2	1	15	2	—	—	—	—	—
		1.0	700	7	2	3	1	15	2	—	—	—	—	—
		1.5	700	11	4	5	1	15	2	—	—	—	—	—
		2.0	700	15	5	6	1	15	2	2	3	1	15	2
		2.3	700	17	6	7	1	15	2	—	—	—	—	—
		3.0	700	22	7	9	1	15	2	4	5	1	15	2
01	0.63	4.0	700	29	10	12	1	15	2	5	6	1	15	2
		0.8	1000	4	2	2	1	15	2	—	—	—	—	—
		1.0	1000	5	2	3	1	15	2	—	—	—	—	—
		1.5	1000	8	4	5	1	15	2	—	—	—	—	—
		2.0	1000	10	5	6	1	15	2	2	3	1	15	2
		2.3	1000	12	6	7	1	15	2	—	—	—	—	—
		3.0	1000	15	7	9	1	15	2	4	5	1	15	2
		3.8	1000	19	9	11	1	15	2	—	—	—	—	—
		4.0	1000	20	10	12	1	15	2	5	6	1	15	2
		4.5	1000	23	11	14	1	15	2	—	—	—	—	—
02	0.61	5.0	1000	25	12	15	1	20	2	6	8	1	15	2
		6.0	1000	31	14	18	1	20	2	7	9	1	15	2
		3.8	1400	14	9	11	1	15	2	—	—	—	—	—
		4.5	1400	17	11	14	1	15	2	—	—	—	—	—
		5.0	1400	19	12	15	1	20	2	6	8	1	15	2
		5.3	1400	20	13	16	1	20	2	—	—	—	—	—
		6.0	1400	22	14	18	1	20	2	7	9	1	15	2
		6.8	1400	25	16	20	1	25	2	—	—	—	—	—
		7.0	1400	26	17	21	1	25	2	8	11	1	15	2
		7.5	1400	28	18	23	1	25	2	—	—	—	—	—
03	0.61	8.0	1400	30	19	24	1	25	2	10	12	1	15	2
		9.0	1400	33	22	27	1	30	2	11	14	1	15	2
		10.0	1400	37	24	30	1	35	2	12	15	1	20	2
		3.8	2000	10	9	11	1	15	2	—	—	—	—	—
		4.5	2000	12	11	14	1	15	2	—	—	—	—	—
		5.0	2000	13	12	15	1	20	2	6	8	1	15	2
		5.3	2000	14	13	16	1	20	2	—	—	—	—	—
		6.0	2000	16	14	18	1	20	2	7	9	1	15	2
		6.8	2000	18	16	20	1	25	2	—	—	—	—	—
		7.0	2000	18	17	21	1	25	2	8	11	1	15	2
7.5	2000	19	18	23	1	25	2	—	—	—	—	—		
8.0	2000	21	19	24	1	25	2	10	12	1	15	2		
9.0	2000	23	22	27	1	30	2	11	14	1	15	2		
10.0	2000	26	24	30	1	35	2	12	15	1	20	2		

#### LEGEND

- AHRI — Air-Conditioning, Heating and Refrigeration Institute
- CKT — Circuit
- FLA — Full Load Amps
- MCA — Maximum Circuit Amps
- MOCP — Maximum Overcurrent Protection

\*MCA = 1.25 x FLA. For proper wiring size, refer to Table 310-16 of the NEC (National Electrical Code).

#### NOTES:

1. Subcircuits are internal heater circuits of 48 amps or less.
2. Electric heat performance is not within the scope of AHRI standard 430 certification.
3. To avoid damage due to overheating, minimum face velocity cannot fall below 350 fpm.
4. Single phase heaters 6 kW and below have 1 control step; all others have 2 controls steps as standard.
5. Heater kW offering is controlled by the AHUBuilder® program. This table for reference only.
6. A 240-v rated heater with 230-v supply shall be derated 8%.
7. A 240-v rated heater with 208-v supply shall be derated 25%.

### ELECTRIC HEATER DATA (cont)

#### 39SHK 3 PHASE (cont)

39SHK UNIT SIZE	HEATER AREA (sq ft)	HEATER COIL (kW)	NOMINAL COIL FACE VELOCITY (fpm)	TEMP RISE (°F)	240-3-60 (V-Ph-Hz)					480-3-60 (V-Ph-Hz)				
					TOTAL FLA	MCA*	NO. SUB CKT	MOCP	NO. CONTROL STEPS	TOTAL FLA	MCA*	NO. SUB CKT	MOCP	NO. CONTROL STEPS
04	0.87	3.8	1900	7	9	11	1	15	2	—	—	—	—	—
		4.5	1900	9	11	14	1	15	2	—	—	—	—	—
		5.0	1900	10	12	15	1	20	2	6	8	1	15	2
		5.3	1900	10	13	16	1	20	2	—	—	—	—	—
		6.0	1900	12	14	18	1	20	2	7	9	1	15	2
		6.8	1900	13	16	20	1	25	2	—	—	—	—	—
		7.0	1900	14	17	21	1	25	2	8	11	1	15	2
		7.5	1900	14	18	23	1	25	2	—	—	—	—	—
		8.0	1900	15	19	24	1	25	2	10	12	1	15	2
		8.3	1900	16	20	25	1	25	2	—	—	—	—	—
		9.0	1900	17	22	27	1	30	2	11	14	1	15	2
		9.8	1900	19	24	29	1	30	2	—	—	—	—	—
		10.0	1900	19	24	30	1	35	2	12	15	1	20	2
		10.5	1900	20	25	32	1	35	2	—	—	—	—	—
		11.0	1900	21	26	33	1	35	2	13	17	1	20	2
		11.3	1900	22	27	34	1	35	2	—	—	—	—	—
		12.0	1900	23	29	36	1	40	2	14	18	1	20	2
		12.8	1900	25	31	38	1	40	2	—	—	—	—	—
13.0	1900	25	31	39	1	40	2	16	20	1	20	2		
14.0	1900	27	34	42	1	45	2	17	21	1	25	2		
15.0	1900	29	36	45	1	50	2	18	23	1	25	2		
16.0	1900	31	38	48	1	50	2	19	24	1	25	2		
17.0	1900	33	41	51	1	60	2	20	26	1	30	2		
05	1.20	7.5	1700	12	18	23	1	25	2	—	—	—	—	—
		8.0	1700	13	—	—	—	—	—	—	—	—	—	—
		8.3	1700	13	20	25	1	25	2	—	—	—	—	—
		9.0	1700	14	22	27	1	30	2	—	—	—	—	—
		9.8	1700	15	24	29	1	30	2	—	—	—	—	—
		10.0	1700	16	24	30	1	35	2	12	15	1	20	2
		10.5	1700	16	25	32	1	35	2	—	—	—	—	—
		11.0	1700	17	26	33	1	35	2	13	17	1	20	2
		11.3	1700	18	27	34	1	35	2	—	—	—	—	—
		12.0	1700	19	29	36	1	40	2	14	18	1	20	2
		12.8	1700	20	31	38	1	40	2	—	—	—	—	—
		13.0	1700	20	31	39	1	40	2	16	20	1	20	2
		13.5	1700	21	32	41	1	45	2	—	—	—	—	—
		14.0	1700	22	34	42	1	45	2	17	21	1	25	2
		14.3	1700	22	34	43	1	45	2	—	—	—	—	—
15.0	1700	23	36	45	1	50	2	18	23	1	25	2		
16.0	1700	25	38	48	1	50	2	19	24	1	25	2		
17.0	1700	27	41	51	1	60	2	20	26	1	30	2		
18.0	1700	28	43	54	1	60	2	22	27	1	30	2		
19.0	1700	30	46	57	1	60	2	23	29	1	30	2		

**LEGEND**

- AHRI** — Air-Conditioning, Heating and Refrigeration Institute
- CKT** — Circuit
- FLA** — Full Load Amps
- MCA** — Maximum Circuit Amps
- MOCP** — Maximum Overcurrent Protection

\*MCA = 1.25 x FLA. For proper wiring size, refer to Table 310-16 of the NEC (National Electrical Code).

**NOTES:**

1. Subcircuits are internal heater circuits of 48 amps or less.
2. Electric heat performance is not within the scope of AHRI standard 430 certification.
3. To avoid damage due to overheating, minimum face velocity cannot fall below 350 fpm.
4. Single phase heaters 6 kW and below have 1 control step; all others have 2 controls steps as standard.
5. Heater kW offering is controlled by the **AHUBuilder®** program. This table for reference only.
6. A 240-v rated heater with 230-v supply shall be derated 8%.
7. A 240-v rated heater with 208-v supply shall be derated 25%.

## ELECTRIC HEATER DATA (cont)

### 39SHK 3 PHASE (cont)

39SHK UNIT SIZE	HEATER AREA (sq ft)	HEATER COIL (kW)	NOMINAL COIL FACE VELOCITY (fpm)	TEMP RISE (°F)	240-3-60 (V-Ph-Hz)					480-3-60 (V-Ph-Hz)					
					TOTAL FLA	MCA*	NO. SUB CKT	MOCP	NO. CONTROL STEPS	TOTAL FLA	MCA*	NO. SUB CKT	MOCP	NO. CONTROL STEPS	
07	1.50	9.0	2000	10	22	27	1	30	2	—	—	—	—	—	
		9.8	2000	10	24	29	1	30	2	—	—	—	—	—	
		10.0	2000	11	—	—	—	—	—	—	12	15	1	20	2
		10.5	2000	11	25	32	1	35	2	—	—	—	—	—	
		11.0	2000	12	—	—	—	—	—	—	13	17	1	20	2
		11.3	2000	12	27	34	1	35	2	—	—	—	—	—	
		12.0	2000	13	29	36	1	40	2	—	—	—	—	—	
		12.8	2000	14	31	38	1	40	2	—	—	—	—	—	
		13.0	2000	14	31	39	1	40	2	—	—	—	—	—	
		13.5	2000	14	32	41	1	45	2	—	—	—	—	—	
		14.0	2000	15	34	42	1	45	2	—	—	—	—	—	
		14.3	2000	15	34	43	1	45	2	—	—	—	—	—	
		15.0	2000	16	36	45	1	50	2	—	—	—	—	—	
		15.8	2000	17	38	48	1	50	2	—	—	—	—	—	
		16.0	2000	17	38	48	1	50	2	—	—	—	—	—	
		17.0	2000	18	41	51	1	60	2	—	—	—	—	—	
		18.0	2000	19	43	54	1	60	2	—	—	—	—	—	
19.0	2000	20	46	57	1	60	2	—	—	—	—	—			
20.0	2000	21	48	60	2	70	2	—	—	—	—	—			
21.0	2000	22	51	63	2	70	2	—	—	—	—	—			
09	1.50	10.0	2700	8	—	—	—	—	—	12	15	1	20	2	
		11.0	2700	9	—	—	—	—	—	13	17	1	20	2	
		12.0	2700	9	—	—	—	—	—	14	18	1	20	2	
		12.8	2700	10	31	38	1	40	2	—	—	—	—	—	
		13.0	2700	10	—	—	—	—	—	16	20	1	20	2	
		13.5	2700	11	32	41	1	45	2	—	—	—	—	—	
		14.0	2700	11	—	—	—	—	—	17	21	1	25	2	
		14.3	2700	11	34	43	1	45	2	—	—	—	—	—	
		15.0	2700	12	36	45	1	50	2	—	—	—	—	—	
		15.8	2700	12	38	48	1	50	2	—	—	—	—	—	
		16.0	2700	13	—	—	—	—	—	—	19	24	1	25	2
		17.0	2700	13	41	51	1	60	2	—	—	—	—	—	
		18.0	2700	14	43	54	1	60	2	—	—	—	—	—	
19.0	2700	15	46	57	1	60	2	—	—	—	—	—			
20.0	2700	16	48	60	2	70	2	—	—	—	—	—			
21.0	2700	17	51	63	2	70	2	—	—	—	—	—			

#### LEGEND

**AHRI** — Air-Conditioning, Heating and Refrigeration Institute  
**CKT** — Circuit  
**FLA** — Full Load Amps  
**MCA** — Maximum Circuit Amps  
**MOCP** — Maximum Overcurrent Protection

\*MCA = 1.25 x FLA. For proper wiring size, refer to Table 310-16 of the NEC (National Electrical Code).

#### NOTES:

- Subcircuits are internal heater circuits of 48 amps or less.
- Electric heat performance is not within the scope of AHRI standard 430 certification.
- To avoid damage due to overheating, minimum face velocity cannot fall below 350 fpm.
- Single phase heaters 6 kW and below have 1 control step; all others have 2 controls steps as standard.
- Heater kW offering is controlled by the **AHUBuilder®** program. This table for reference only.
- A 240-v rated heater with 230-v supply shall be derated 8%.
- A 240-v rated heater with 208-v supply shall be derated 25%.

## ELECTRIC HEATER DATA (cont)

### 39SM SINGLE PHASE

39SM UNIT SIZE	HEATER AREA (sq ft)	HEATER COIL (kW)	NOMINAL COIL FACE VELOCITY (fpm)	TEMP RISE (°F)	240-1-60 (V-Ph-Hz)					277-1-60 (V-Ph-Hz)				
					TOTAL FLA	MCA*	NO. SUB CKT	MOCP	NO. CONTROL STEPS	TOTAL FLA	MCA*	NO. SUB CKT	MOCP	NO. CONTROL STEPS
04	1.12	5	1500	10	21	26	1	30	1	18	23	1	25	1
		6	1500	12	25	31	1	35	1	22	27	1	30	1
		7	1500	14	29	36	1	40	2	25	32	1	35	2
		8	1500	16	33	42	1	45	2	29	36	1	40	2
		9	1500	18	38	47	1	50	2	32	41	1	45	2
		10	1500	20	42	52	1	60	2	26	45	1	50	2
		11	1500	22	46	57	1	60	2	40	50	1	50	2
05	1.12	12	1500	24	50	63	2	70	2	—	—	—	—	—
		5	1800	8	21	26	1	30	1	18	23	1	25	1
		6	1800	10	25	31	1	35	1	22	27	1	30	1
		7	1800	11	29	36	1	40	2	25	32	1	35	2
		8	1800	13	33	42	1	45	2	29	36	1	40	2
		9	1800	14	38	47	1	50	2	32	41	1	45	2
		10	1800	16	42	52	1	60	2	26	45	1	50	2
07	1.50	11	1800	18	46	57	1	60	2	40	50	1	50	2
		12	1800	19	50	63	2	70	2	—	—	—	—	—
		5	2000	5	21	26	1	30	1	18	23	1	25	1
		6	2000	6	25	31	1	35	1	22	27	1	30	1
		7	2000	7	29	36	1	40	2	25	32	1	35	2
		8	2000	9	33	42	1	45	2	29	36	1	40	2
		9	2000	10	38	47	1	50	2	32	41	1	45	2
		10	2000	11	42	52	1	60	2	36	45	1	50	2
		11	2000	12	46	57	2	60	2	40	50	1	50	2
		12	2000	13	50	63	2	70	2	—	—	—	—	—
		13	2000	14	54	68	2	70	2	—	—	—	—	—
		14	2000	15	58	73	2	80	2	—	—	—	—	—
		15	2000	16	63	78	2	80	2	—	—	—	—	—
		16	2000	17	67	83	2	90	2	—	—	—	—	—
		17	2000	18	71	89	2	90	2	—	—	—	—	—
		18	2000	19	75	94	2	100	2	—	—	—	—	—
		19	2000	20	79	99	2	100	2	—	—	—	—	—
		20	2000	21	83	104	2	110	2	—	—	—	—	—
		21	2000	22	88	109	2	110	2	—	—	—	—	—
		22	2000	23	92	115	2	125	2	—	—	—	—	—
		23	2000	24	96	120	2	125	2	—	—	—	—	—
24	2000	26	100	125	3	150	2	—	—	—	—	—		
25	2000	27	104	130	3	150	2	—	—	—	—	—		
26	2000	28	108	135	3	150	2	—	—	—	—	—		
27	2000	29	113	141	3	150	2	—	—	—	—	—		
28	2000	30	117	146	3	150	2	—	—	—	—	—		
29	2000	31	121	151	3	175	2	—	—	—	—	—		

**LEGEND**

**AHRI** — Air-Conditioning, Heating and Refrigeration Institute  
**CKT** — Circuit  
**FLA** — Full Load Amps  
**MCA** — Maximum Circuit Amps  
**MOCP** — Maximum Overcurrent Protection

\*MCA = 1.25 x FLA. For proper wiring size, refer to Table 310-16 of the NEC (National Electrical Code).

**NOTES:**

1. Subcircuits are internal heater circuits of 48 amps or less.
2. Electric heat performance is not within the scope of AHRI standard 430 certification.
3. To avoid damage due to overheating, minimum face velocity cannot fall below 350 fpm.
4. Single phase heaters 6 kW and below have 1 control step; all others have 2 controls steps as standard.
5. Heater kW offering is controlled by the **AHUBuilder®** program. This table for reference only.
6. A 240-v rated heater with 230-v supply shall be derated 8%.
7. A 240-v rated heater with 208-v supply shall be derated 25%.



## ELECTRIC HEATER DATA (cont)

### 39SM SINGLE PHASE (cont)

39SM UNIT SIZE	HEATER AREA (sq ft)	HEATER COIL (kW)	NOMINAL COIL FACE VELOCITY (fpm)	TEMP RISE (°F)	240-1-60 (V-Ph-Hz)					277-1-60 (V-Ph-Hz)				
					TOTAL FLA	MCA*	NO. SUB CKT	MOCP	NO. CONTROL STEPS	TOTAL FLA	MCA*	NO. SUB CKT	MOCP	NO. CONTROL STEPS
09	1.50	5	2700	4	21	26	1	30	1	18	23	1	25	1
		6	2700	5	25	31	1	35	1	22	27	1	30	1
		7	2700	6	29	36	1	40	2	25	32	1	35	2
		8	2700	6	33	42	1	45	2	29	36	1	40	2
		9	2700	7	38	47	1	50	2	32	41	1	45	2
		10	2700	8	42	52	1	60	2	36	45	1	50	2
		11	2700	9	46	57	2	60	2	40	50	1	50	2
		12	2700	10	50	63	2	70	2	—	—	—	—	—
		13	2700	10	54	68	2	70	2	—	—	—	—	—
		14	2700	11	58	73	2	80	2	—	—	—	—	—
		15	2700	12	63	78	2	80	2	—	—	—	—	—
		16	2700	13	67	83	2	90	2	—	—	—	—	—
		17	2700	14	71	89	2	90	2	—	—	—	—	—
		18	2700	14	75	94	2	100	2	—	—	—	—	—
		19	2700	15	79	99	2	100	2	—	—	—	—	—
		20	2700	16	83	104	2	110	2	—	—	—	—	—
		21	2700	17	88	109	2	110	2	—	—	—	—	—
		22	2700	18	92	115	2	125	2	—	—	—	—	—
		23	2700	18	96	120	2	125	2	—	—	—	—	—
		24	2700	19	100	125	3	150	2	—	—	—	—	—
25	2700	20	104	130	3	150	2	—	—	—	—	—		
26	2700	21	108	135	3	150	2	—	—	—	—	—		
27	2700	22	113	141	3	150	2	—	—	—	—	—		
28	2700	22	117	146	3	150	2	—	—	—	—	—		
29	2700	23	121	151	3	175	2	—	—	—	—	—		

#### LEGEND

- AHRI — Air-Conditioning, Heating and Refrigeration Institute
- CKT — Circuit
- FLA — Full Load Amps
- MCA — Maximum Circuit Amps
- MOCP — Maximum Overcurrent Protection

\*MCA = 1.25 x FLA. For proper wiring size, refer to Table 310-16 of the NEC (National Electrical Code).

#### NOTES:

1. Subcircuits are internal heater circuits of 48 amps or less.
2. Electric heat performance is not within the scope of AHRI standard 430 certification.
3. To avoid damage due to overheating, minimum face velocity cannot fall below 350 fpm.
4. Single phase heaters 6 kW and below have 1 control step; all others have 2 controls steps as standard.
5. Heater kW offering is controlled by the AHUBuilder® program. This table for reference only.
6. A 240-v rated heater with 230-v supply shall be derated 8%.
7. A 240-v rated heater with 208-v supply shall be derated 25%.

### ELECTRIC HEATER DATA (cont)

#### 39SM 3 PHASE

39SM UNIT SIZE	HEATER AREA (sq ft)	HEATER COIL (kW)	NOMINAL COIL FACE VELOCITY (fpm)	TEMP RISE (°F)	240-3-60 (V-Ph-Hz)					480-3-60 (V-Ph-Hz)				
					TOTAL FLA	MCA*	NO. SUB CKT	MOCP	NO. CONTROL STEPS	TOTAL FLA	MCA*	NO. SUB CKT	MOCP	NO. CONTROL STEPS
04	1.12	5	1500	10	12	15	1	20	2	6	8	1	15	2
		6	1500	12	14	18	1	20	2	7	9	1	15	2
		7	1500	14	17	21	1	25	2	8	11	1	15	2
		8	1500	16	19	24	1	25	2	10	12	1	15	2
		9	1500	18	22	27	1	30	2	11	14	1	15	2
		10	1500	20	24	30	1	35	2	12	15	1	20	2
		11	1500	22	26	33	1	35	2	13	17	1	20	2
		12	1500	24	29	36	1	40	2	14	18	1	20	2
05	1.12	5	1800	8	12	15	1	20	2	6	8	1	15	2
		6	1800	10	14	18	1	20	2	7	9	1	15	2
		7	1800	11	17	21	1	25	2	8	11	1	15	2
		8	1800	13	19	24	1	25	2	10	12	1	15	2
		9	1800	14	22	27	1	30	2	11	14	1	15	2
		10	1800	16	24	30	1	35	2	12	15	1	20	2
		11	1800	18	26	33	1	35	2	13	17	1	20	2
		12	1800	19	29	36	1	40	2	14	18	1	20	2
07	1.50	5	2000	5	12	15	1	20	2	6	8	1	15	2
		6	2000	6	14	18	1	20	2	7	9	1	15	2
		7	2000	7	17	21	1	25	2	8	11	1	15	2
		8	2000	9	19	24	1	25	2	10	12	1	15	2
		9	2000	10	22	27	1	30	2	11	14	1	15	2
		10	2000	11	24	30	1	35	2	12	15	1	20	2
		11	2000	12	26	33	1	35	2	13	17	1	20	2
		12	2000	13	29	36	1	40	2	14	18	1	20	2
		13	2000	14	31	39	1	40	2	16	20	1	20	2
		14	2000	15	34	42	1	45	2	17	21	1	25	2
		15	2000	16	36	45	1	50	2	18	23	1	25	2
		16	2000	17	38	48	1	50	2	19	24	1	25	2
		17	2000	18	41	51	1	60	2	20	26	1	30	2
		18	2000	19	43	54	1	60	2	22	27	1	30	2
		19	2000	20	46	57	1	60	2	23	29	1	30	2
		20	2000	21	48	60	2	70	2	24	30	1	35	2
		21	2000	22	51	63	2	70	2	25	32	1	35	2
		22	2000	23	53	66	2	70	2	—	—	—	—	—
		23	2000	24	55	69	2	70	2	—	—	—	—	—
		24	2000	26	58	72	2	80	2	—	—	—	—	—
		25	2000	27	60	75	2	80	2	—	—	—	—	—
26	2000	28	63	78	2	80	2	—	—	—	—	—		
27	2000	29	65	81	2	90	2	—	—	—	—	—		
28	2000	30	67	84	2	90	2	—	—	—	—	—		
29	2000	31	70	87	2	90	2	—	—	—	—	—		

**LEGEND**

- AHRI** — Air-Conditioning, Heating and Refrigeration Institute
- CKT** — Circuit
- FLA** — Full Load Amps
- MCA** — Maximum Circuit Amps
- MOCP** — Maximum Overcurrent Protection

\*MCA = 1.25 x FLA. For proper wiring size, refer to Table 310-16 of the NEC (National Electrical Code).

**NOTES:**

1. Subcircuits are internal heater circuits of 48 amps or less.
2. Electric heat performance is not within the scope of AHRI standard 430 certification.
3. To avoid damage due to overheating, minimum face velocity cannot fall below 350 fpm.
4. Single phase heaters 6 kW and below have 1 control step; all others have 2 controls steps as standard.
5. Heater kW offering is controlled by the **AHUBuilder®** program. This table for reference only.
6. A 240-v rated heater with 230-v supply shall be derated 8%.
7. A 240-v rated heater with 208-v supply shall be derated 25%.

# Performance data (cont)



## ELECTRIC HEATER DATA (cont)

### 39SM 3 PHASE (cont)

39SM UNIT SIZE	HEATER AREA (sq ft)	HEATER COIL (kW)	NOMINAL COIL FACE VELOCITY (fpm)	TEMP RISE (°F)	240-3-60 (V-Ph-Hz)					480-3-60 (V-Ph-Hz)				
					TOTAL FLA	MCA*	NO. SUB CKT	MOCP	NO. CONTROL STEPS	TOTAL FLA	MCA*	NO. SUB CKT	MOCP	NO. CONTROL STEPS
09	1.50	5	2700	4	12	15	1	20	2	6	8	1	15	2
		6	2700	5	14	18	1	20	2	7	9	1	15	2
		7	2700	6	17	21	1	25	2	8	11	1	15	2
		8	2700	6	19	24	1	25	2	10	12	1	15	2
		9	2700	7	22	27	1	30	2	11	14	1	15	2
		10	2700	8	24	30	1	35	2	12	15	1	20	2
		11	2700	9	26	33	1	35	2	13	17	1	20	2
		12	2700	10	29	36	1	40	2	14	18	1	20	2
		13	2700	10	31	39	1	40	2	16	20	1	20	2
		14	2700	11	34	42	1	45	2	17	21	1	25	2
		15	2700	12	36	45	1	50	2	18	23	1	25	2
		16	2700	13	38	48	1	50	2	19	24	1	25	2
		17	2700	14	41	51	1	60	2	20	26	1	30	2
		18	2700	14	43	54	1	60	2	22	27	1	30	2
		19	2700	15	46	57	1	60	2	23	29	1	30	2
		20	2700	16	48	60	2	70	2	24	30	1	35	2
		21	2700	17	51	63	2	70	2	25	32	1	35	2
		22	2700	18	53	66	2	70	2	—	—	—	—	—
		23	2700	18	55	69	2	70	2	—	—	—	—	—
		24	2700	19	58	72	2	80	2	—	—	—	—	—
25	2700	20	60	75	2	80	2	—	—	—	—	—		
26	2700	21	63	78	2	80	2	—	—	—	—	—		
27	2700	22	65	81	2	90	2	—	—	—	—	—		
28	2700	22	67	84	2	90	2	—	—	—	—	—		
29	2700	23	70	87	2	90	2	—	—	—	—	—		

**LEGEND**

- AHRI** — Air-Conditioning, Heating and Refrigeration Institute
- CKT** — Circuit
- FLA** — Full Load Amps
- MCA** — Maximum Circuit Amps
- MOCP** — Maximum Overcurrent Protection

\*MCA = 1.25 x FLA. For proper wiring size, refer to Table 310-16 of the NEC (National Electrical Code).

**NOTES:**

1. Subcircuits are internal heater circuits of 48 amps or less.
2. Electric heat performance is not within the scope of AHRI standard 430 certification.
3. To avoid damage due to overheating, minimum face velocity cannot fall below 350 fpm.
4. Single phase heaters 6 kW and below have 1 control step; all others have 2 controls steps as standard.
5. Heater kW offering is controlled by the **AHUBuilder®** program. This table for reference only.
6. A 240-v rated heater with 230-v supply shall be derated 8%.
7. A 240-v rated heater with 208-v supply shall be derated 25%.

### ELECTRIC HEATER DATA (cont)

#### 39SV SINGLE PHASE

39SV UNIT SIZE	HEATER AREA (sq ft)	HEATER COIL (kW)	NOMINAL COIL FACE VELOCITY (fpm)	TEMP RISE (°F)	240-1-60 (V-Ph-Hz)					277-1-60 (V-Ph-Hz)				
					TOTAL FLA	MCA*	NO. SUB CKT	MOCP	NO. CONTROL STEPS	TOTAL FLA	MCA*	NO. SUB CKT	MOCP	NO. CONTROL STEPS
02	0.70	1	1200	4	4	5	1	15	1	4	5	1	15	1
		2	1200	8	8	10	1	15	1	7	9	1	15	1
		3	1200	11	13	16	1	20	1	11	14	1	15	1
		4	1200	15	17	21	1	25	1	14	18	1	15	1
		5	1200	19	21	26	1	30	1	18	23	1	15	1
		6	1200	23	25	31	1	35	1	22	27	1	15	1
		7	1200	27	29	36	1	40	2	25	32	1	15	1
		8	1200	31	33	42	1	45	2	29	36	1	15	1
		9	1200	34	38	47	1	50	2	32	41	1	15	2
		10	1200	38	42	52	1	60	2	36	45	1	20	2
03	0.70	1	1800	3	4	5	1	15	1	4	5	1	15	1
		2	1800	5	8	10	1	15	1	7	9	1	15	1
		3	1800	8	13	16	1	20	1	11	14	1	15	1
		4	1800	10	17	21	1	25	1	14	18	1	15	1
		5	1800	13	21	26	1	30	1	18	23	1	15	1
		6	1800	15	25	31	1	35	1	22	27	1	15	1
		7	1800	18	29	36	1	40	2	25	32	1	15	1
		8	1800	20	33	42	1	45	2	29	36	1	15	1
		9	1800	23	38	47	1	50	2	32	41	1	15	2
		10	1800	25	42	52	1	60	2	36	45	1	20	2
04	0.87	1	1900	2	4	5	1	15	1	4	5	1	15	1
		2	1900	4	8	10	1	15	1	7	9	1	15	1
		3	1900	6	13	16	1	20	1	11	14	1	15	1
		4	1900	8	17	21	1	25	1	14	18	1	20	1
		5	1900	10	21	26	1	30	1	18	23	1	25	1
		6	1900	12	25	31	1	35	1	22	27	1	30	1
		7	1900	13	29	36	1	40	2	25	32	1	35	2
		8	1900	15	33	42	1	45	2	29	36	1	40	2
		9	1900	17	38	47	1	50	2	32	41	1	45	2
		10	1900	19	42	52	1	60	2	36	45	1	50	2
		11	1900	21	46	57	1	60	2	40	50	1	50	2
		12	1900	23	50	63	2	70	2	—	—	—	—	—
		13	1900	25	54	68	2	70	2	—	—	—	—	—
		14	1900	27	58	73	2	80	2	—	—	—	—	—
		15	1900	29	63	78	2	80	2	—	—	—	—	—
		16	1900	31	67	83	2	90	2	—	—	—	—	—
		17	1900	33	71	89	2	90	2	—	—	—	—	—

**LEGEND**

- AHRI** — Air-Conditioning, Heating and Refrigeration Institute
- CKT** — Circuit
- FLA** — Full Load Amps
- MCA** — Maximum Circuit Amps
- MOCP** — Maximum Overcurrent Protection

\*MCA = 1.25 x FLA. For proper wiring size, refer to Table 310-16 of the NEC (National Electrical Code).

**NOTES:**

1. Subcircuits are internal heater circuits of 48 amps or less.
2. Electric heat performance is not within the scope of AHRI standard 430 certification.
3. To avoid damage due to overheating, minimum face velocity cannot fall below 350 fpm.
4. Single phase heaters 6 kW and below have 1 control step; all others have 2 controls steps as standard.
5. Heater kW offering is controlled by the **AHUBuilder®** program. This table for reference only.
6. A 240-v rated heater with 230-v supply shall be derated 8%.
7. A 240-v rated heater with 208-v supply shall be derated 25%.

# Performance data (cont)



## ELECTRIC HEATER DATA (cont)

### 39SV SINGLE PHASE (cont)

39SV UNIT SIZE	HEATER AREA (sq ft)	HEATER COIL (kW)	NOMINAL COIL VELOCITY (fpm)	TEMP RISE (°F)	240-1-60 (V-Ph-Hz)					277-1-60 (V-Ph-Hz)				
					TOTAL FLA	MCA*	NO. SUB CKT	MOCP	NO. CONTROL STEPS	TOTAL FLA	MCA*	NO. SUB CKT	MOCP	NO. CONTROL STEPS
05	1.21	5	1700	8	21	26	1	30	1	18	23	1	25	1
		6	1700	9	25	31	1	35	1	22	27	1	30	1
		7	1700	11	29	36	1	40	2	25	32	1	35	2
		8	1700	12	33	42	1	45	2	29	36	1	40	2
		9	1700	14	38	47	1	50	2	32	41	1	45	2
		10	1700	16	42	52	1	60	2	36	45	1	50	2
		11	1700	17	46	57	1	60	2	—	—	—	—	—
		12	1700	19	50	63	2	70	2	—	—	—	—	—
		13	1700	20	54	68	2	70	2	—	—	—	—	—
		14	1700	22	58	73	2	80	2	—	—	—	—	—
		15	1700	23	63	78	2	80	2	—	—	—	—	—
		16	1700	25	67	83	2	90	2	—	—	—	—	—
		17	1700	26	71	89	2	90	2	—	—	—	—	—
07	1.50	5	2000	5	21	26	1	30	1	18	23	1	25	1
		6	2000	6	25	31	1	35	1	22	27	1	30	1
		7	2000	7	29	36	1	40	2	25	32	1	35	2
		8	2000	9	33	42	1	45	2	29	36	1	49	2
		9	2000	10	38	47	1	50	2	32	41	1	45	2
		10	2000	11	42	52	1	60	2	36	45	1	50	2
		11	2000	12	46	57	1	60	2	40	50	1	50	2
		12	2000	13	50	63	2	70	2	—	—	—	—	—
		13	2000	14	54	68	2	70	2	—	—	—	—	—
		14	2000	15	58	73	2	80	2	—	—	—	—	—
		15	2000	16	63	78	2	80	2	—	—	—	—	—
		16	2000	17	67	83	2	90	2	—	—	—	—	—
		17	2000	18	71	89	2	90	2	—	—	—	—	—
18	2000	19	75	94	2	100	2	—	—	—	—	—		
19	2000	20	79	99	2	100	2	—	—	—	—	—		
20	2000	21	83	104	2	110	2	—	—	—	—	—		
21	2000	22	88	109	2	110	2	—	—	—	—	—		
09	1.50	5	2700	4	21	26	1	30	1	18	23	1	25	1
		6	2700	5	25	31	1	35	1	22	27	1	30	1
		7	2700	6	29	36	1	40	2	25	32	1	35	2
		8	2700	6	33	42	1	45	2	29	36	1	49	2
		9	2700	7	38	47	1	50	2	32	41	1	45	2
		10	2700	8	42	52	1	60	2	36	45	1	50	2
		11	2700	9	46	57	1	60	2	40	50	1	50	2
		12	2700	9	50	63	2	70	2	—	—	—	—	—
		13	2700	10	54	68	2	70	2	—	—	—	—	—
		14	2700	11	58	73	2	80	2	—	—	—	—	—
		15	2700	12	63	78	2	80	2	—	—	—	—	—
		16	2700	13	67	83	2	90	2	—	—	—	—	—
		17	2700	13	71	89	2	90	2	—	—	—	—	—
18	2700	14	75	94	2	100	2	—	—	—	—	—		
19	2700	15	79	99	2	100	2	—	—	—	—	—		
20	2700	16	83	104	2	110	2	—	—	—	—	—		
21	2700	17	88	109	2	110	2	—	—	—	—	—		

#### LEGEND

- AHRI — Air-Conditioning, Heating and Refrigeration Institute
- CKT — Circuit
- FLA — Full Load Amps
- MCA — Maximum Circuit Amps
- MOCP — Maximum Overcurrent Protection

\*MCA = 1.25 x FLA. For proper wiring size, refer to Table 310-16 of the NEC (National Electrical Code).

#### NOTES:

1. Subcircuits are internal heater circuits of 48 amps or less.
2. Electric heat performance is not within the scope of AHRI standard 430 certification.
3. To avoid damage due to overheating, minimum face velocity cannot fall below 350 fpm.
4. Single phase heaters 6 kW and below have 1 control step; all others have 2 controls steps as standard.
5. Heater kW offering is controlled by the AHUBuilder® program. This table for reference only.
6. A 240-v rated heater with 230-v supply shall be derated 8%.
7. A 240-v rated heater with 208-v supply shall be derated 25%.

### ELECTRIC HEATER DATA (cont)

#### 39SV 3 PHASE

39SV UNIT SIZE	HEATER AREA (sq ft)	HEATER COIL (kW)	NOMINAL COIL FACE VELOCITY (fpm)	TEMP RISE (°F)	240-3-60 (V-Ph-Hz)					480-3-60 (V-Ph-Hz)				
					TOTAL FLA	MCA*	NO. SUB CKT	MOCP	NO. CONTROL STEPS	TOTAL FLA	MCA*	NO. SUB CKT	MOCP	NO. CONTROL STEPS
02	0.70	1	1200	4	2	3	1	15	2	1	2	1	15	2
		2	1200	8	5	6	1	15	2	2	3	1	15	2
		3	1200	11	7	9	1	15	2	4	5	1	15	2
		4	1200	15	10	12	1	15	2	5	6	1	15	2
		5	1200	19	12	15	1	20	2	6	8	1	15	2
		6	1200	23	14	18	1	20	2	7	9	1	15	2
		7	1200	27	17	21	1	25	2	8	11	1	15	2
		8	1200	31	19	24	1	25	2	10	12	1	15	2
		9	1200	34	22	27	1	30	2	11	14	1	15	2
		10	1200	38	24	30	1	35	2	12	15	1	20	2
03	0.70	1	1800	3	2	3	1	15	2	1	2	1	15	2
		2	1800	5	5	6	1	15	2	2	3	1	15	2
		3	1800	8	7	9	1	15	2	4	5	1	15	2
		4	1800	10	10	12	1	15	2	5	6	1	15	2
		5	1800	13	12	15	1	20	2	6	8	1	15	2
		6	1800	15	14	18	1	20	2	7	9	1	15	2
		7	1800	18	17	21	1	25	2	8	11	1	15	2
		8	1800	20	19	24	1	25	2	10	12	1	15	2
		9	1800	23	22	27	1	30	2	11	14	1	15	2
		10	1800	25	24	30	1	35	2	12	15	1	20	2
04	0.87	1	1900	2	4	5	1	15	1	—	—	—	—	—
		2	1900	4	8	10	1	15	1	—	—	—	—	—
		3	1900	6	13	16	1	20	1	4	5	1	15	2
		4	1900	8	17	21	1	25	1	5	6	1	15	2
		5	1900	10	21	26	1	30	1	6	8	1	15	2
		6	1900	12	25	31	1	35	1	7	9	1	15	2
		7	1900	13	29	36	1	40	2	8	11	1	15	2
		8	1900	15	33	42	1	45	2	10	12	1	15	2
		9	1900	17	38	47	1	50	2	11	14	1	15	2
		10	1900	19	42	52	1	60	2	12	15	1	20	2
		11	1900	21	46	57	1	60	2	13	17	1	20	2
		12	1900	23	50	63	2	70	2	14	18	1	20	2
		13	1900	25	54	68	2	70	2	16	20	1	20	2
		14	1900	27	58	73	2	80	2	17	21	1	25	2
		15	1900	29	63	78	2	80	2	18	23	1	25	2
		16	1900	31	67	83	2	90	2	19	24	1	25	2
		17	1900	33	71	89	2	90	2	20	26	1	30	2

**LEGEND**

- AHRI** — Air-Conditioning, Heating and Refrigeration Institute
- CKT** — Circuit
- FLA** — Full Load Amps
- MCA** — Maximum Circuit Amps
- MOCP** — Maximum Overcurrent Protection

\*MCA = 1.25 x FLA. For proper wiring size, refer to Table 310-16 of the NEC (National Electrical Code).

**NOTES:**

1. Subcircuits are internal heater circuits of 48 amps or less.
2. Electric heat performance is not within the scope of AHRI standard 430 certification.
3. To avoid damage due to overheating, minimum face velocity cannot fall below 350 fpm.
4. Single phase heaters 6 kW and below have 1 control step; all others have 2 controls steps as standard.
5. Heater kW offering is controlled by the **AHUBuilder®** program. This table for reference only.
6. A 240-v rated heater with 230-v supply shall be derated 8%.
7. A 240-v rated heater with 208-v supply shall be derated 25%.



## ELECTRIC HEATER DATA (cont)

### 39SV 3 PHASE (cont)

39SV UNIT SIZE	HEATER AREA (sq ft)	HEATER COIL (kW)	NOMINAL COIL FACE VELOCITY (fpm)	TEMP RISE (°F)	240-3-60 (V-Ph-Hz)					480-3-60 (V-Ph-Hz)				
					TOTAL FLA	MCA*	NO. SUB CKT	MOCP	NO. CONTROL STEPS	TOTAL FLA	MCA*	NO. SUB CKT	MOCP	NO. CONTROL STEPS
05	1.21	5	1700	8	12	15	1	20	2	6	8	1	15	2
		6	1700	9	14	18	1	20	2	7	9	1	15	2
		7	1700	11	17	21	1	25	2	8	11	1	15	2
		8	1700	12	19	24	1	25	2	10	12	1	15	2
		9	1700	14	22	27	1	30	2	11	14	1	15	2
		10	1700	16	24	30	1	35	2	12	15	1	20	2
		11	1700	17	26	33	1	35	2	13	17	1	20	2
		12	1700	19	29	36	1	40	2	14	18	1	20	2
		13	1700	20	31	39	1	40	2	16	20	1	20	2
		14	1700	22	34	42	1	45	2	17	21	1	25	2
		15	1700	23	36	45	1	50	2	18	23	1	25	2
		16	1700	25	38	48	1	50	2	19	24	1	25	2
		17	1700	26	41	51	1	60	2	20	26	1	30	2
18	1700	28	43	54	1	60	2	22	27	1	30	2		
19	1700	29	46	57	1	60	2	23	29	1	30	2		
07	1.50	5	2000	5	12	15	1	20	2	6	8	1	15	2
		6	2000	6	14	18	1	20	2	7	9	1	15	2
		7	2000	7	17	21	1	25	2	8	11	1	15	2
		8	2000	9	19	24	1	25	2	10	12	1	15	2
		9	2000	10	22	27	1	30	2	11	14	1	15	2
		10	2000	11	24	30	1	35	2	12	15	1	20	2
		11	2000	12	26	33	1	35	2	13	17	1	20	2
		12	2000	13	29	36	1	40	2	14	18	1	20	2
		13	2000	14	31	39	1	40	2	16	20	1	20	2
		14	2000	15	34	42	1	45	2	17	21	1	25	2
		15	2000	16	36	45	1	50	2	18	23	1	25	2
		16	2000	17	38	48	1	50	2	19	24	1	25	2
		17	2000	18	41	51	1	60	2	20	26	1	30	2
18	2000	19	43	54	1	60	2	22	27	1	30	2		
19	2000	20	46	57	1	60	2	23	29	1	30	2		
20	2000	21	48	60	2	70	2	24	30	1	35	2		
21	2000	22	51	63	2	70	2	25	32	1	35	2		
09	1.50	5	2700	4	12	15	1	20	2	6	8	1	15	2
		6	2700	5	14	18	1	20	2	7	9	1	15	2
		7	2700	6	17	21	1	25	2	8	11	1	15	2
		8	2700	6	19	24	1	25	2	10	12	1	15	2
		9	2700	7	22	27	1	30	2	11	14	1	15	2
		10	2700	8	24	30	1	35	2	12	15	1	20	2
		11	2700	9	26	33	1	35	2	13	17	1	20	2
		12	2700	9	29	36	1	40	2	14	18	1	20	2
		13	2700	10	31	39	1	40	2	16	20	1	20	2
		14	2700	11	34	42	1	45	2	17	21	1	25	2
		15	2700	12	36	45	1	50	2	18	23	1	25	2
		16	2700	13	38	48	1	50	2	19	24	1	25	2
		17	2700	13	41	51	1	60	2	20	26	1	30	2
18	2700	14	43	54	1	60	2	22	27	1	30	2		
19	2700	15	46	57	1	60	2	23	29	1	30	2		
20	2700	16	48	60	2	70	2	24	30	1	35	2		
21	2700	17	51	63	2	70	2	25	32	1	35	2		

**LEGEND**

- AHRI** — Air-Conditioning, Heating and Refrigeration Institute
- CKT** — Circuit
- FLA** — Full Load Amps
- MCA** — Maximum Circuit Amps
- MOCP** — Maximum Overcurrent Protection

4. Single phase heaters 6 kW and below have 1 control step; all others have 2 controls steps as standard.
5. Heater kW offering is controlled by the **AHUBuilder®** program. This table for reference only.
6. A 240-v rated heater with 230-v supply shall be derated 8%.
7. A 240-v rated heater with 208-v supply shall be derated 25%.

\*MCA = 1.25 x FLA. For proper wiring size, refer to Table 310-16 of the NEC (National Electrical Code).

**NOTES:**

1. Subcircuits are internal heater circuits of 48 amps or less.
2. Electric heat performance is not within the scope of AHRI standard 430 certification.
3. To avoid damage due to overheating, minimum face velocity cannot fall below 350 fpm.

## 39SHK UNIT

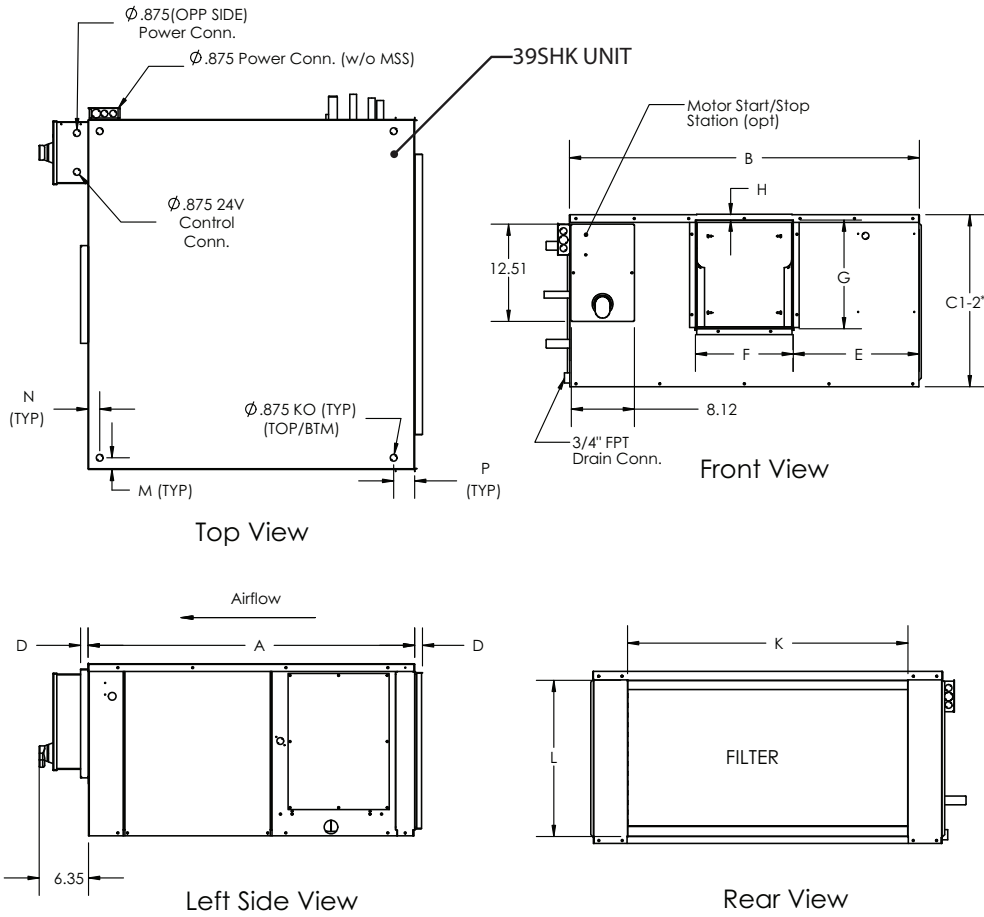

### DIMENSIONS (in.)

39SHK UNIT SIZE	UNIT OUTLINE					BLOWER OPENING OUTLET				RETURN DUCT CONNECTION				
	A	B	C1*	C2*	D	E	F	G	H	K	L	m	N	P
00,01	38.0	28.0	14.1	15.1	1.0	9.6	8.6	10.6	1.0	22.0	12.3	1.6	2.6	3.3
02,03	37.1	36.6	18.1	19.0	1.0	14.1	8.4	10.6	1.0	27.6	16.4	1.5	1.5	2.9
04	42.0	45.0	22.1	23.0	1.0	17.9	9.1	13.8	1.0	36.0	20.0	1.5	1.5	2.7
05	42.0	45.0	22.1	23.0	1.0	14.3	12.5	13.8	1.0	36.0	20.0	1.5	1.5	2.7
07,09	52.5	57.0	34.8	34.8	1.0	21.8	13.4	16.2	9.1	48.0	32.2	2.8	2.8	2.8
13	57.5	67.2	43.0	43.0	N/A	11.4†	16.4†(2)	16.4†(2)	8.0	57.9	40.4	3.7	3.7	3.7
17	57.5	72.3	48.0	48.0	N/A	14.0†	16.4†(2)	16.4†(2)	13.0	66.0	45.7	3.7	3.7	3.7

#### LEGEND

- BTM** — Bottom
- KO** — Knockout
- w/o MSS** — Without Motor Start/Stop Station

\* C1 dimension is for standard unit. C2 dimension is for double-wall units.

† Sizes 13 and 17 are twin blowers. Dimension E is to closest blower. Dimensions F and G are typical for both fan outlets.

#### NOTES:

1. Dimensions shown in inches.
2. Unit hand is determined by looking into the filters in same direction as airflow. Right hand unit shown for reference.

## 39SHK MIXING BOX

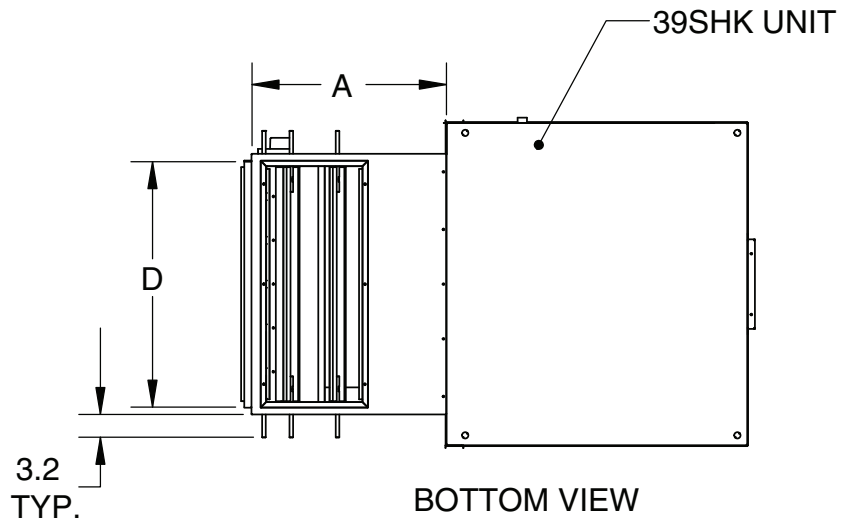
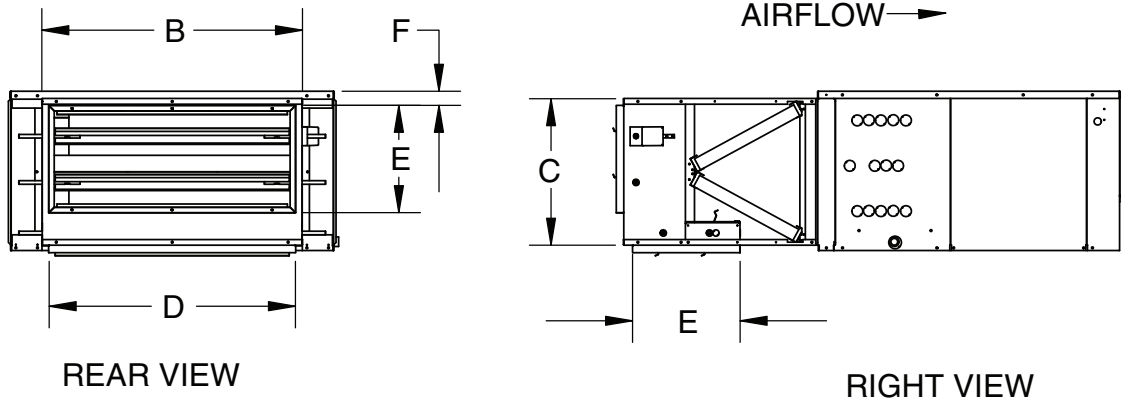

### DIMENSIONS (in.)

39SHK UNIT SIZE	LENGTH	WIDTH (CENTERED)	HEIGHT (CENTERED)	DUCT WIDTH	DUCT HEIGHT	TOP CLEARANCE	APPROX. SHIPPING WEIGHT lb	FILTERS	
	A	B	C	D	E	F		Size	Qty
00,01	22.1	22.1	12.3	20.4	7.6	2.0	40	14x20x2	2
02,03	27.0	27.7	16.4	25.9	11.6	2.0	90	16x25x2	2
04,05	27.0	36.2	20.4	34.3	15.0	2.0	140	16x32x2	2
07,09	32.0	48.2	32.4	46.3	15.0	9.7	200	20x24x2	4
13	36.0	58.0	40.3	56.0	16.0	13.2	260	20x25x2 16x25x2	4 2
17	40.0	66.2	45.0	64.3	16.0	15.5	320	30x20x2	6

**NOTES:**

1. 39SHK unit shown for reference.
2. Not all components shown for clarity.
3. Optional actuator shown for reference.
4. Dimensions shown in inches.

### 39SHC UNIT

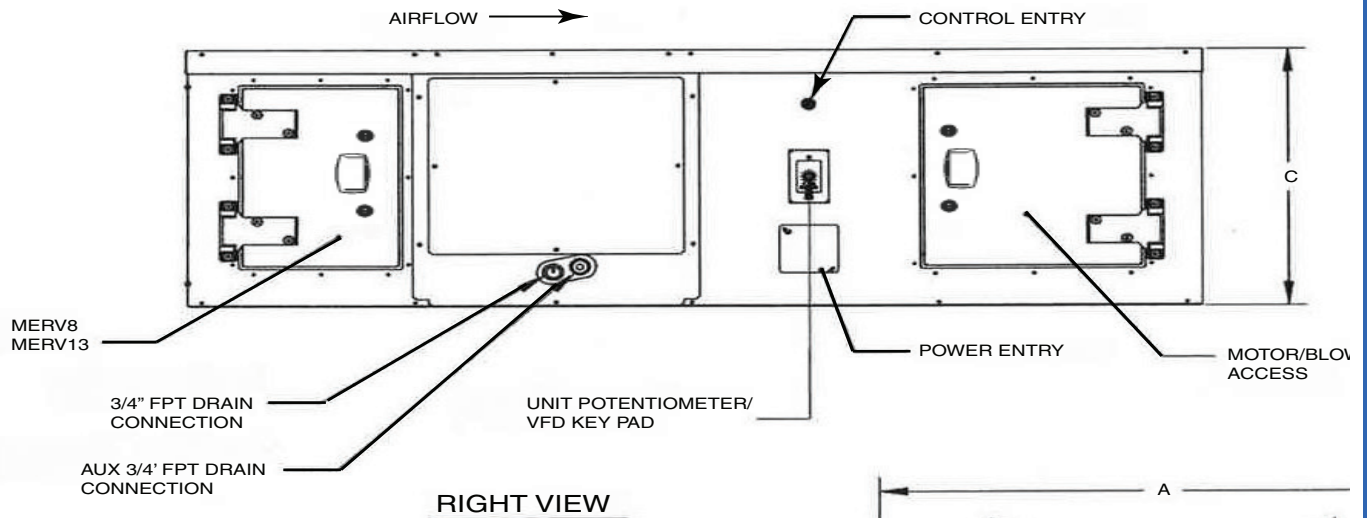
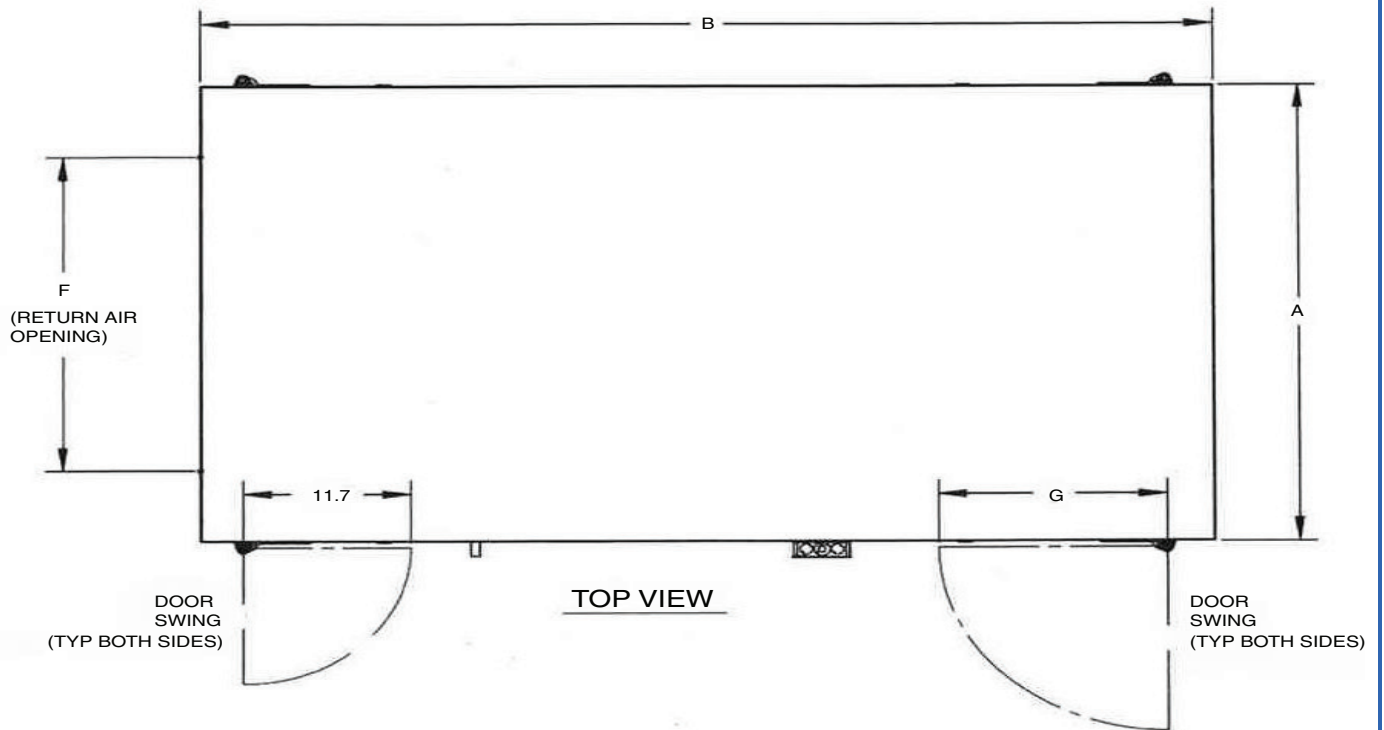

#### DIMENSIONS (in.)

39SHC UNIT SIZE	A	B	C	D	E	F	G
00, 01	33.2	70.4	22	17.8	18.1	21	15.8
02, 03	39.2	70.4	22	23.8	18.1	27	15.8
04, 05	48.2	74.4	28	32.8	24.1	36	19.8
06	48.2	74.4	28	32.8	24.1	36	19.8

**NOTES:**

1. Dimensions shown in inches.
2. Unit potentiometer may be relocated by others in field.
3. Coil connections shown for reference only.

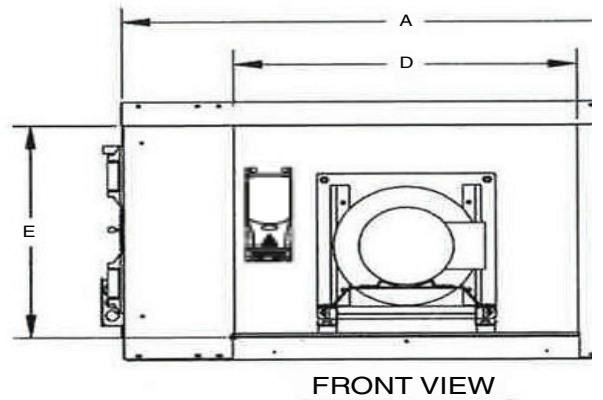

## 39SHF UNIT

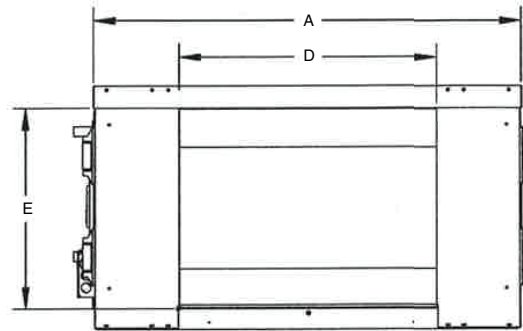
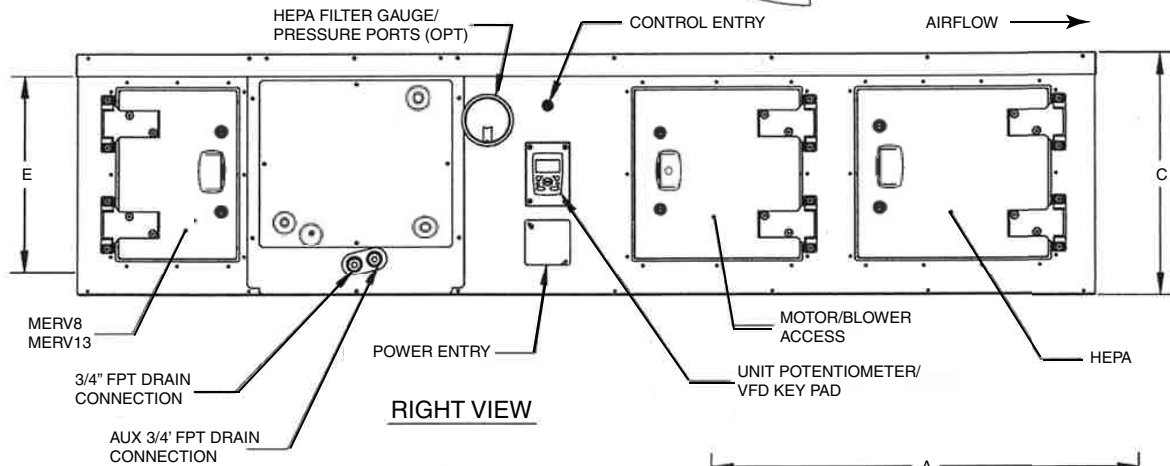
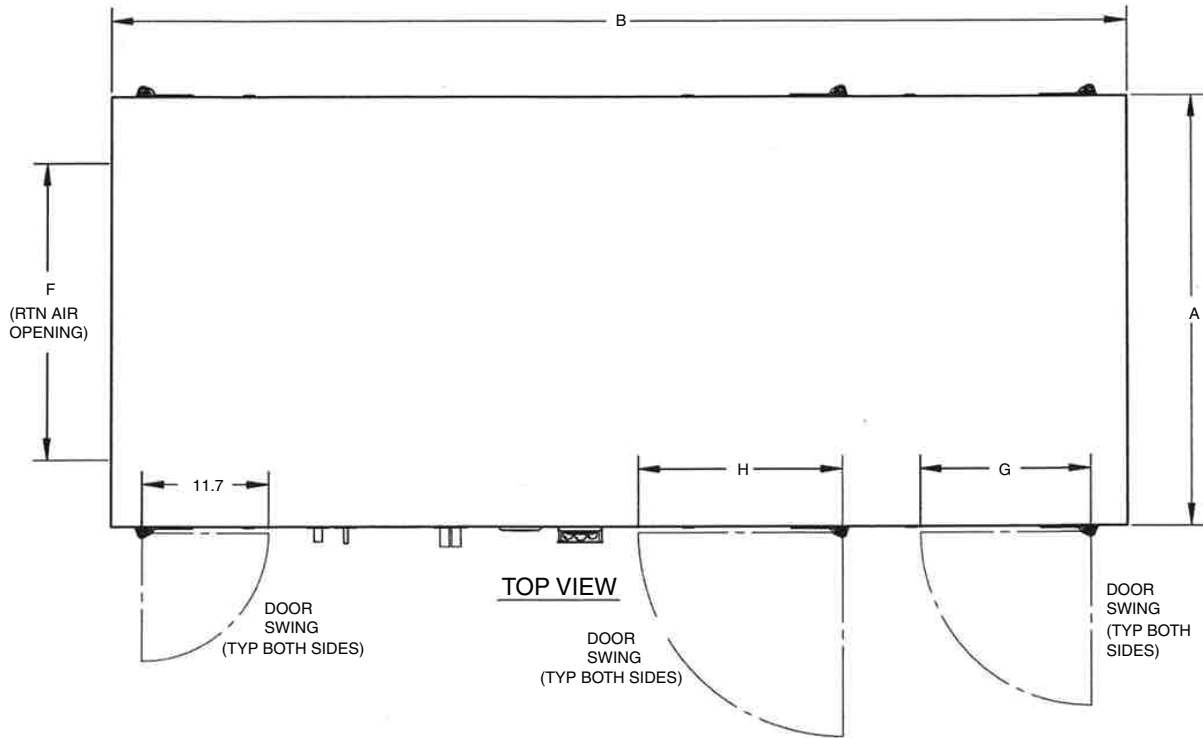

### DIMENSIONS (in.)

39SHF UNIT SIZE	A	B	C	D	E	F	G	H
00,01	33.2	93.4	22	17.8	18.1	21	15.8	18.5
02,03	39.2	93.4	22	23.8	18.1	27	15.8	18.5
04,05	48.2	97.5	28	32.8	24.1	36	19.8	18.6
06	48.2	97.5	28	32.8	24.1	36	19.8	18.6

**NOTES:**

1. Dimensions shown in inches.
2. Unit potentiometer may be relocated by others in field.
3. Coil connections shown for reference only.

### 39SHK ELECTRIC HEAT

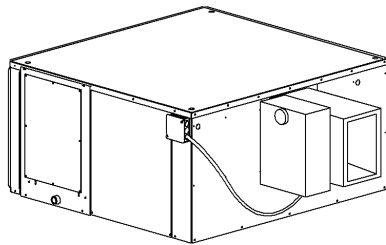

ISOMETRIC VIEW

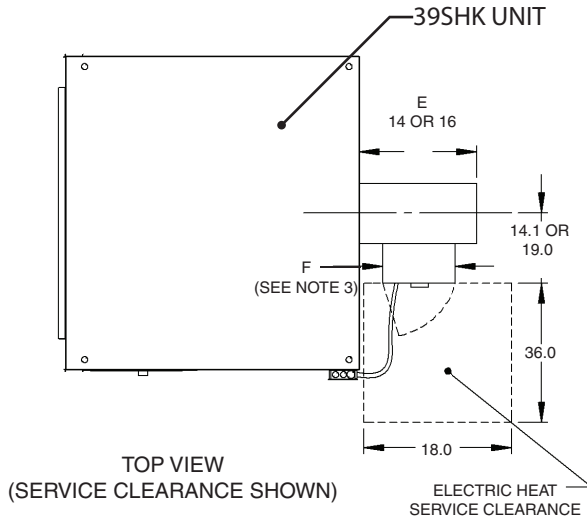

TOP VIEW  
(SERVICE CLEARANCE SHOWN)

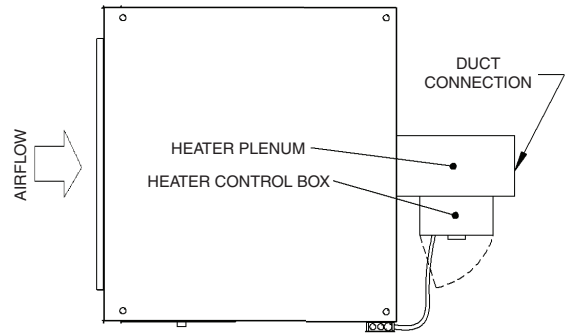

TOP VIEW

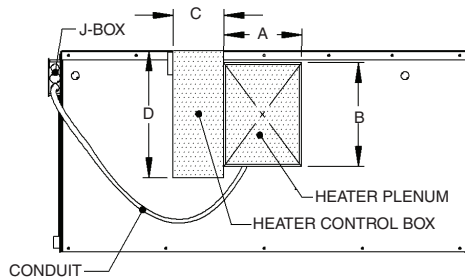

FRONT VIEW

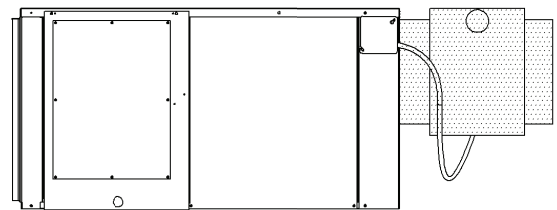

RIGHT VIEW

### DIMENSIONS (in.)

39SHK UNIT SIZE	HEATER PLENUM		HEATER CONTROL BOX	
	A	B	C	D
00,01	8.6	10.6	5.5	14.0
02,03	8.6	10.6	5.5	17.0
04	9.3	13.9	5.5	17.0
05	12.6	13.9	5.5	21.0
07,09	13.4	16.2	5.5	23.0

NOTES:

1. Dimensions shown in inches.
2. Unit with right-hand electric heat is shown for reference. Left hand unit is similar, but with control box on opposite side.
3. Dimension F will be 11.5 in. if dimension E is 14 in., or 14 in. if dimension E is 16 in.



## 39SV UNIT SIZES 02-05 — PRE-HEAT

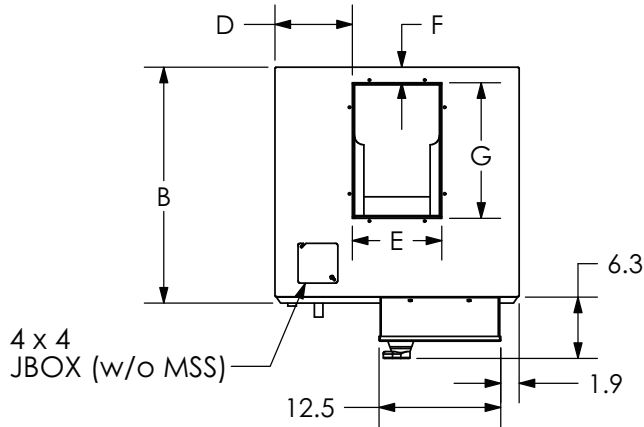

Top View

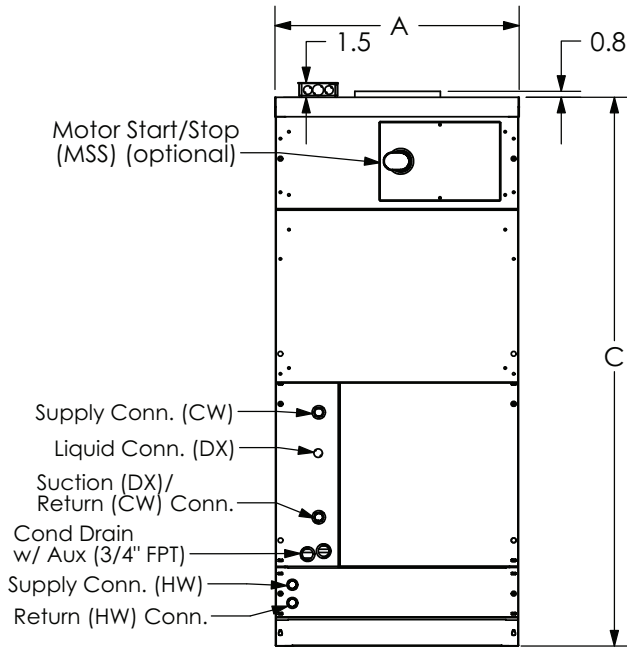

Front View

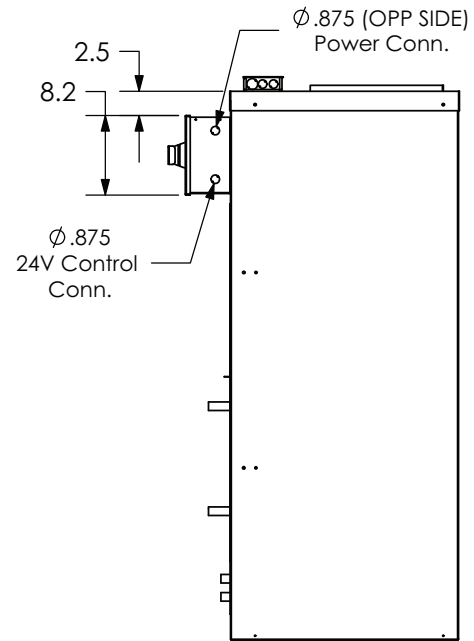

Right View

### DIMENSIONS (in.)

39SV UNIT SIZE	WIDTH	DEPTH	HEIGHT	SUPPLY DUCT				CONNECTION SIZES (OD)		
	A	B	C	D	E	F	G	CW Supply-Return	HW Supply-Return	DX Supply-Return
02	22.3	24.0	50.0	6.9	8.5	3.0	11.8	3/4 - 3/4	7/8 - 7/8	3/8 - 3/4
03	22.3	24.0	50.0	6.9	8.5	3.0	11.8	3/4 - 3/4	7/8 - 7/8	3/8 - 3/4
04	25.1	24.3	56.5	8.0	9.1	1.6	13.9	7/8 - 7/8	7/8 - 7/8	1/2 - 7/8
05	29.5	26.0	59.5	8.4	12.6	1.3	13.9	1 1/8 - 1 1/8	1 1/8 - 1 1/8	1/2 - 1 1/8

#### LEGEND

**CW** — Chilled Water      **MSS** — Motor Start/Stop Station  
**DX** — Direct Expansion      **w/o** — Without  
**HW** — Hot Water

NOTE: Dimensions shown in inches.

### 39SV UNIT SIZE 07 — PRE-HEAT

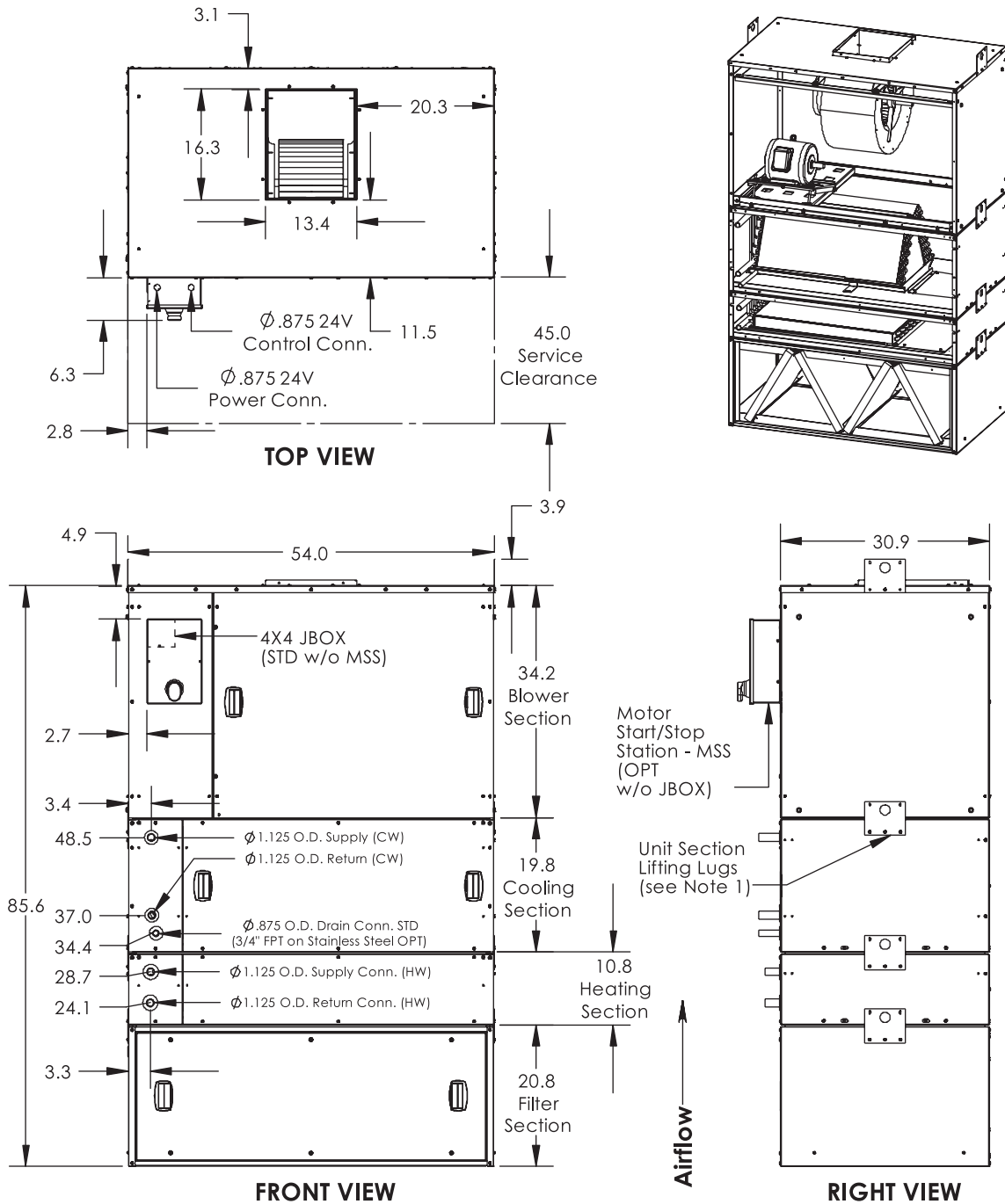

#### LEGEND

**CW** — Chilled Water      **JBOX** — Junction Box  
**HW** — Hot Water          **MSS** — Motor Start/Stop Station  
                                  **w/o** — Without

#### NOTES:

1. Unit section lifting lugs (shipped loose) for lifting sections only. Do not use lifting lugs for lifting unit assembly. Top lifting lugs may be removed after unit is secured at job site.
2. All sections shall be shipped loose and field installed by customer.
3. Dimensions shown in inches.

## 39SV UNIT SIZE 09 — PRE-HEAT

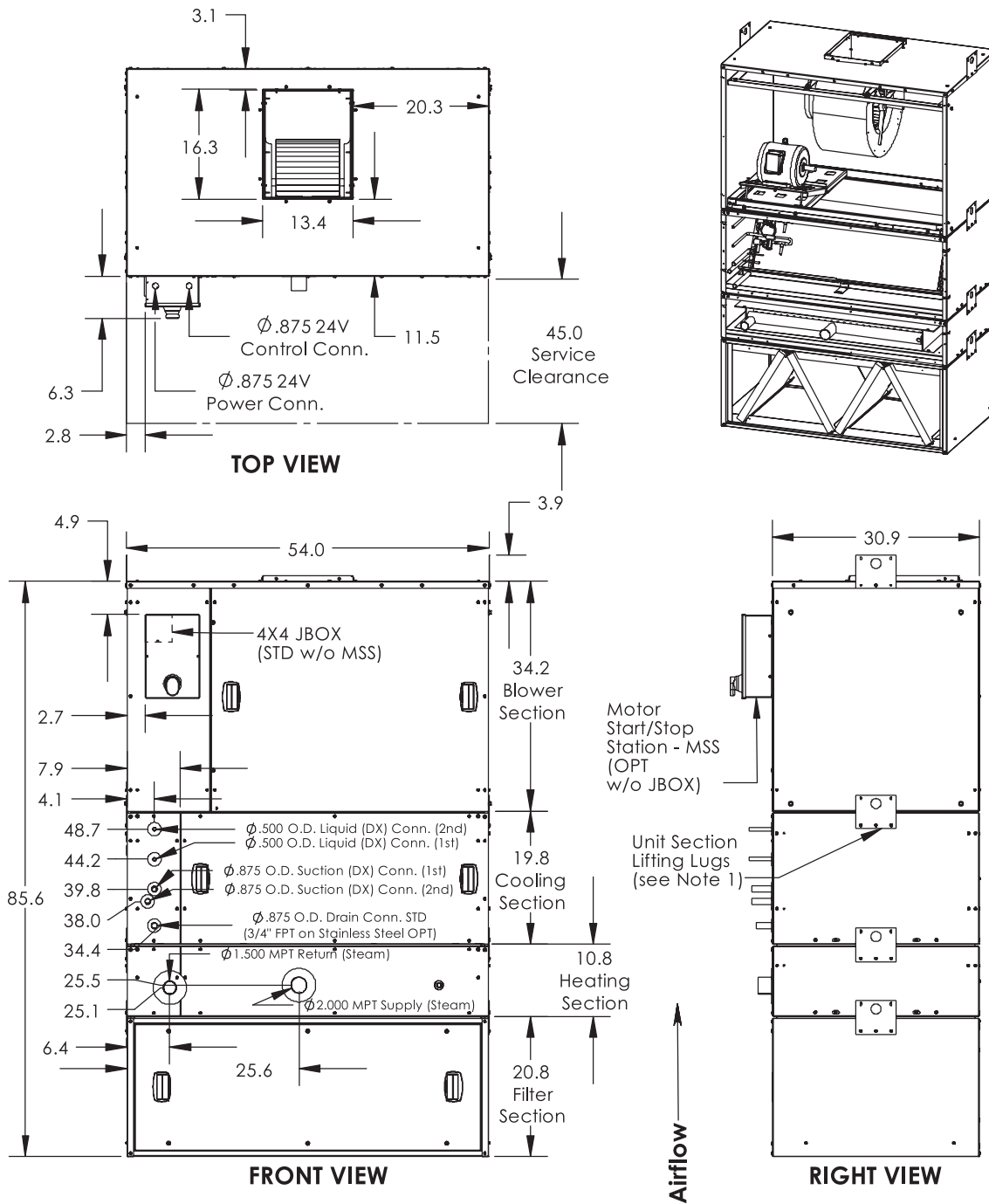

### LEGEND

- DX** — Direct Expansion
- JBOX** — Junction Box
- MSS** — Motor Start/Stop Station
- w/o** — Without

### NOTES:

1. Unit section lifting lugs (shipped loose) for lifting sections only. Do not use lifting lugs for lifting unit assembly. Top lifting lugs may be removed after unit is secured at job site.
2. All sections shall be shipped loose and field installed by customer.
3. Dimensions shown in inches.

### 39SV UNIT SIZE 07 — RE-HEAT

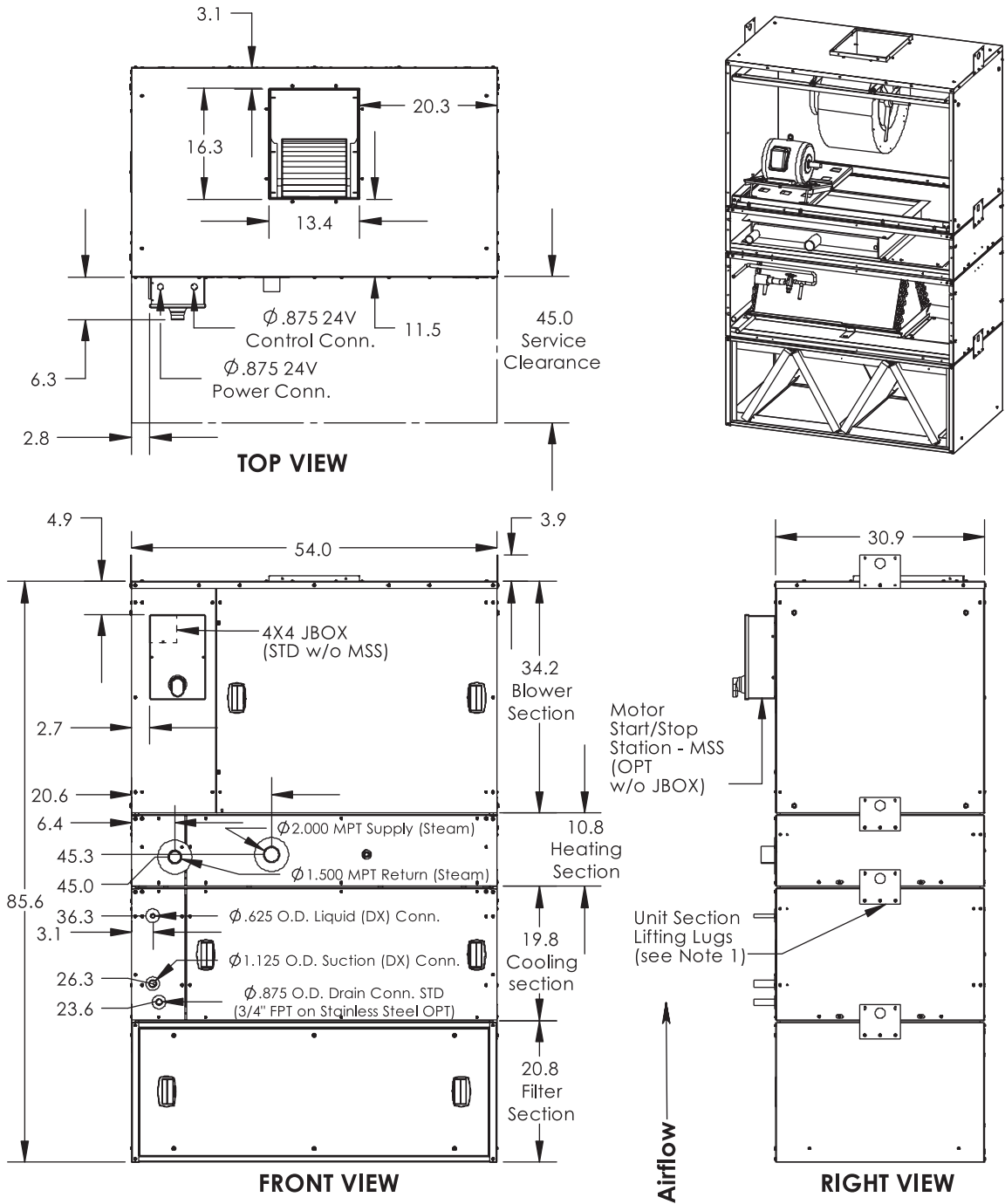

**LEGEND**

- DX** — Direct Expansion
- JBOX** — Junction Box
- MSS** — Motor Start/Stop Station
- w/o** — Without

**NOTES:**

1. Unit section lifting lugs (shipped loose) for lifting sections only. Do not use lifting lugs for lifting unit assembly. Top lifting lugs may be removed after unit is secured at job site.
2. All sections shall be shipped loose and field installed by customer.
3. Dimensions shown in inches.

## 39SV UNIT SIZE 09 — RE-HEAT

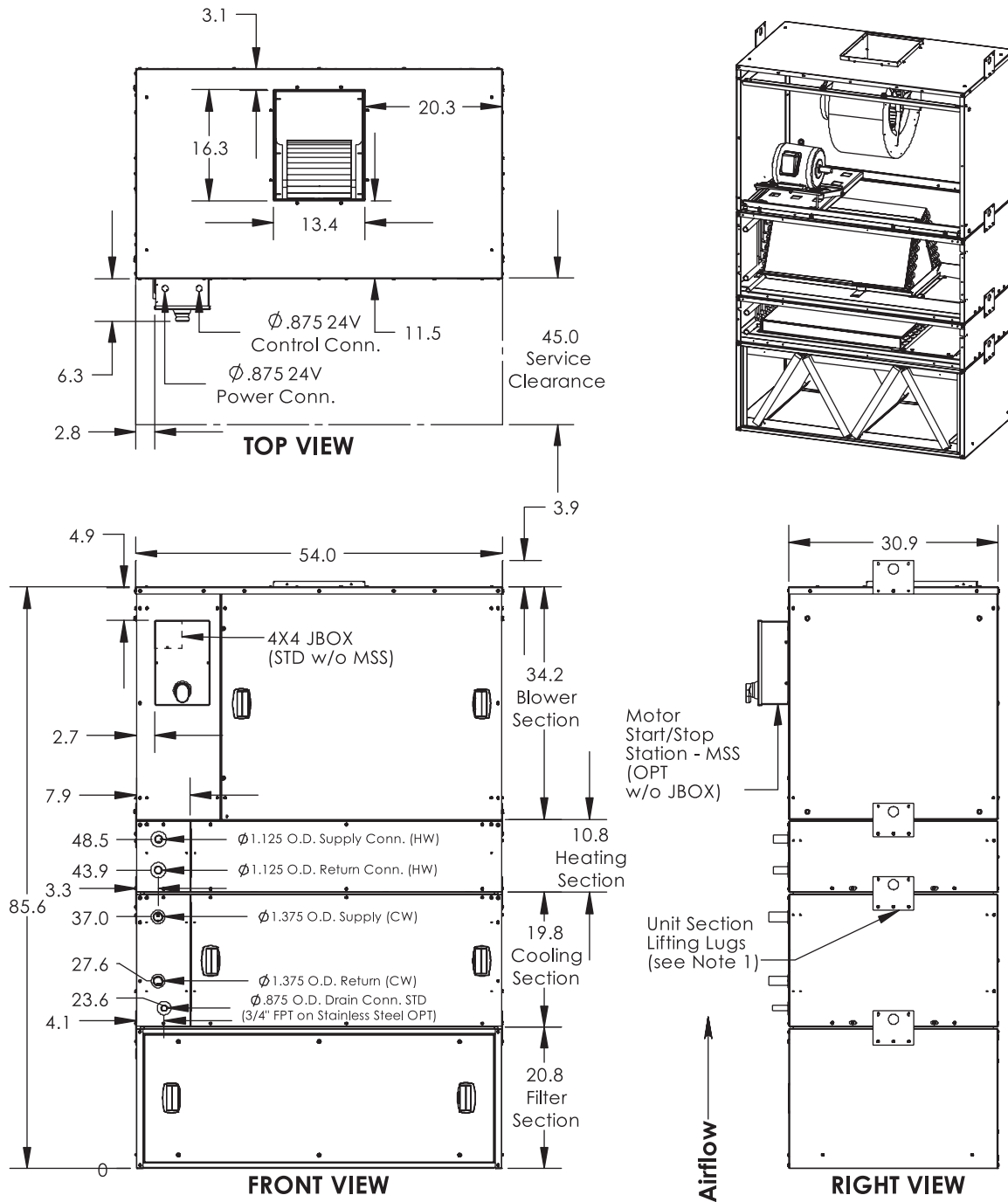

### LEGEND

**CW** — Chilled Water      **MSS** — Motor Start/Stop Station  
**HW** — Hot Water         **w/o** — Without

### NOTES:

1. Unit section lifting lugs (shipped loose) for lifting sections only. Do not use lifting lugs for lifting unit assembly. Top lifting lugs may be removed after unit is secured at job site.
2. All sections shall be shipped loose and field installed by customer.
3. Dimensions shown in inches.

### 39SV — FIELD INSTALLED ELECTRIC HEAT

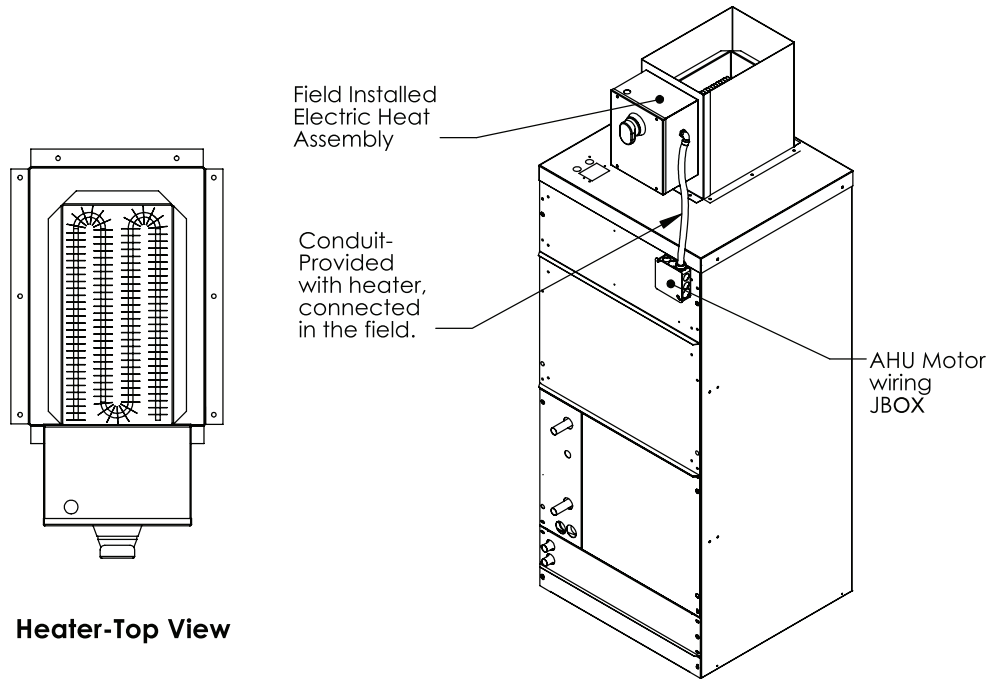

**Heater-Top View**

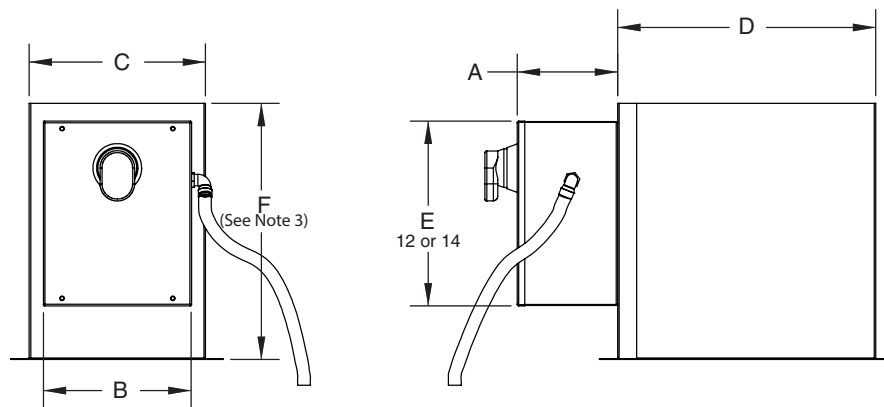

**Heater-Front View**

**Heater-Right View**

#### DIMENSIONS (in.)

39SV UNIT SIZE	HEATER CONTROL BOX		HEATER PLENUM	
	A	B	C	D
02,03	5.5	20.0	8.8	12.1
04	5.5	22.0	9.3	14.1
05	5.5	24.0	13.1	14.4
07,09	5.5	24.0	13.6	16.5

**NOTES:**

1. Dimensions shown in inches.
2. Heater footprint is totally contained within the 39SV unit footprint.
3. Dimension F will be 14 in. if dimension E is 12 in., or 16 in. if dimension E is 14 inches.



## 39SM UNIT — SIZES 04-17 (VERTICAL CONFIGURATION)

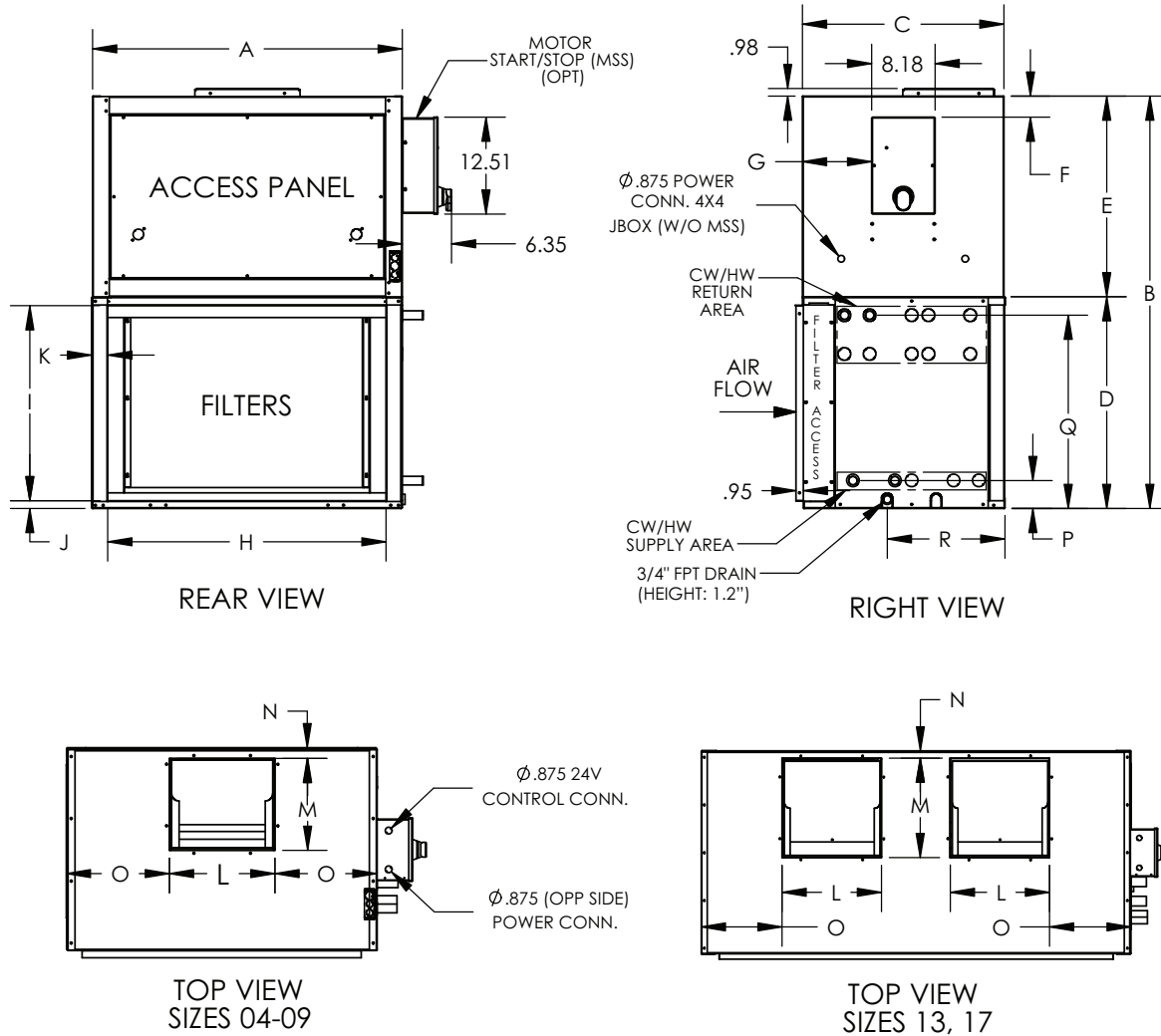

### DIMENSIONS (in.)

39SM UNIT SIZE	WIDTH	HEIGHT	DEPTH	COIL SECTION	BLOWER SECTION	MOTOR START/STOP (OPT.)		RETURN DUCT				SUPPLY DUCT (BLOWER OPENING)				SUPPLY CONN.	RETURN CONN.	DRAIN
	A	B	C	D	E	F	G	H	I	J	K	L	M	N	O	P	Q	R
04	40.0	53.5	26.0	27.5	26.0	2.8	9.0	36.0	25.5	1.0	2.0	13.6	11.9	1.1	13.1	3.6	20.0	15.2
05	40.0	53.5	26.0	27.5	26.0	2.8	9.0	36.0	25.5	1.0	2.0	13.6	11.9	1.1	13.1	3.6	25.0	15.2
07	50.0	68.5	34.0	34.5	34.0	6.8	13.0	48.0	32.0	1.0	1.0	13.4	16.2	1.2	18.3	3.6	25.0	22.5
09	50.0	68.5	34.0	34.5	34.0	6.8	13.0	48.0	32.0	1.0	1.0	13.4	16.2	1.2	18.3	3.6	30.0	22.5
13	72.0	81.5	34.0	47.5	34.0	6.7	13.0	66.0	45.0	2.0	6.0	16.4	16.4	1.1	14.0	3.6	30.0	23.0
17	72.0	81.5	34.0	47.5	34.0	6.7	13.0	66.0	45.0	2.0	6.0	16.4	16.4	1.1	14.0	3.6	42.6	23.0

#### LEGEND

**CW** — Chilled Water  
**HW** — Hot Water  
**w/o MSS** — Without Motor Start/Stop Station

#### NOTES:

- Dimensions shown in inches.
- Hand connections are defined by looking at the filters in the direction of airflow.
- Coil section and blower ship separately and are installed by others.
- Blower section may be rotated 180 degrees to relocate supply duct.

### 39SM UNIT — SIZES 04-17 (HORIZONTAL CONFIGURATION)

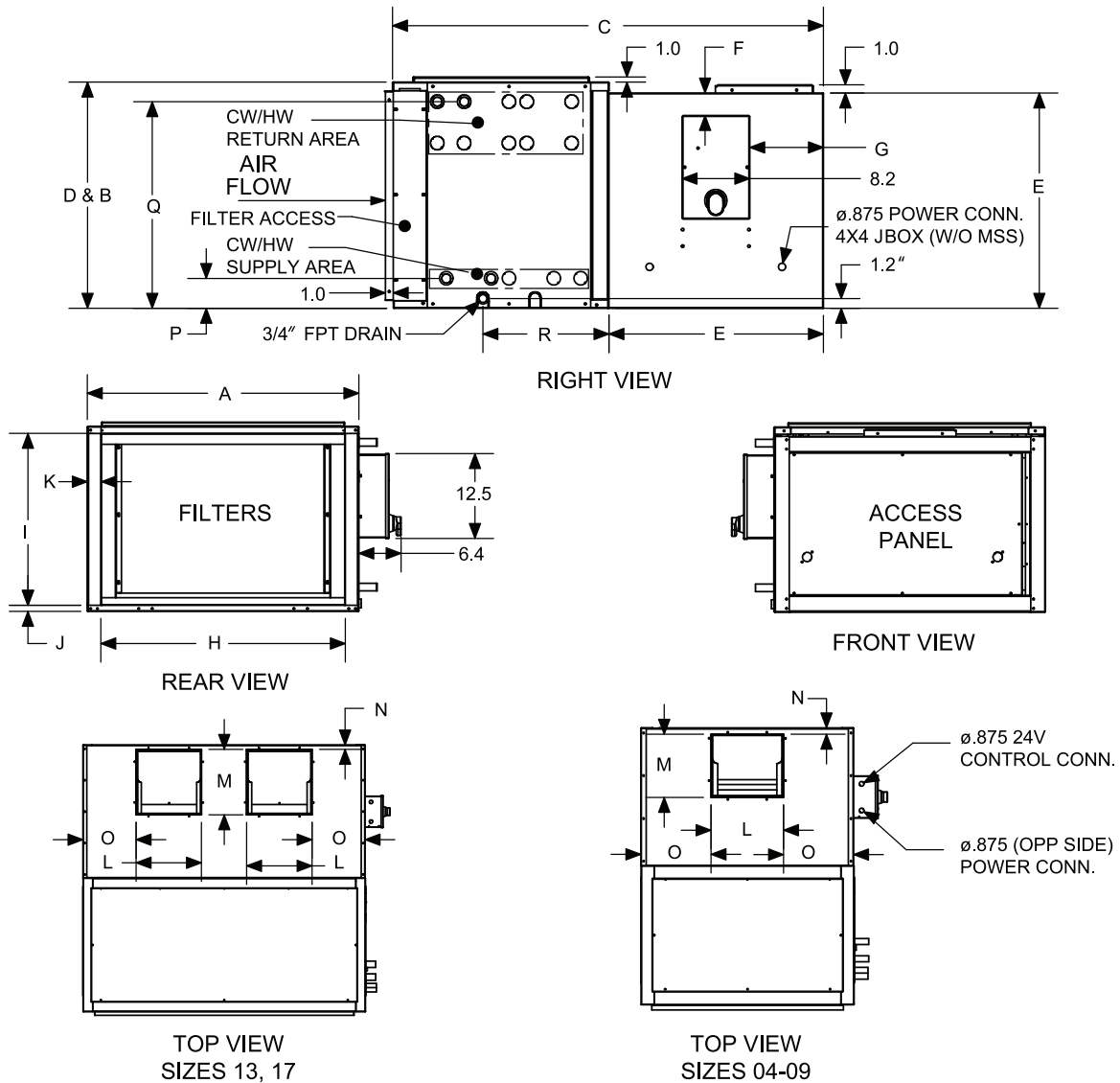

#### DIMENSIONS (in.)

39SM UNIT SIZE	WIDTH	HEIGHT	DEPTH	COIL SECTION	BLOWER SECTION	MOTOR START/STOP (OPT.)		RETURN DUCT				SUPPLY DUCT (BLOWER OPENING)				SUPPLY CONN.	RETURN CONN.	DRAIN
	A	B	C	D	E	F	G	H	I	J	K	L	M	N	O	P	Q	R
04	40.0	27.5	52.0	27.5	26.0	2.7	8.9	36.0	25.5	1.0	2.0	13.6	11.9	1.1	13.1	3.6	20.0	15.2
05	40.0	27.5	52.0	27.5	26.0	2.7	8.9	36.0	25.5	1.0	2.0	13.6	11.9	1.1	13.1	3.6	25.0	15.2
07	50.0	34.5	68.0	34.5	34.0	6.8	12.9	48.0	32.0	1.0	1.0	13.4	16.2	1.2	18.3	3.6	25.0	22.5
09	50.0	34.5	68.0	34.5	34.0	6.8	12.9	48.0	32.0	1.0	1.0	13.4	16.2	1.2	18.3	3.6	30.0	22.5
13	72.0	47.5	68.0	47.5	34.0	6.7	12.9	66.0	45.0	1.0	2.9	16.4	16.4	1.1	14.0	3.6	30.0	23.0
17	72.0	47.5	68.0	47.5	34.0	6.7	12.9	66.0	45.0	1.0	2.9	16.4	16.4	1.1	14.0	3.6	42.6	23.0

#### LEGEND

**CW** — Chilled Water  
**HW** — Hot Water  
**w/o MSS** — Without Motor Start/Stop Station

#### NOTES:

- Dimensions shown in inches.
- Hand connections are defined by looking at the filters in the direction of airflow.
- Coil section and blower ship separately and are installed by others.
- Blower section may be rotated 180 degrees to relocate supply duct.

## 39SM UNIT — MIXING BOX

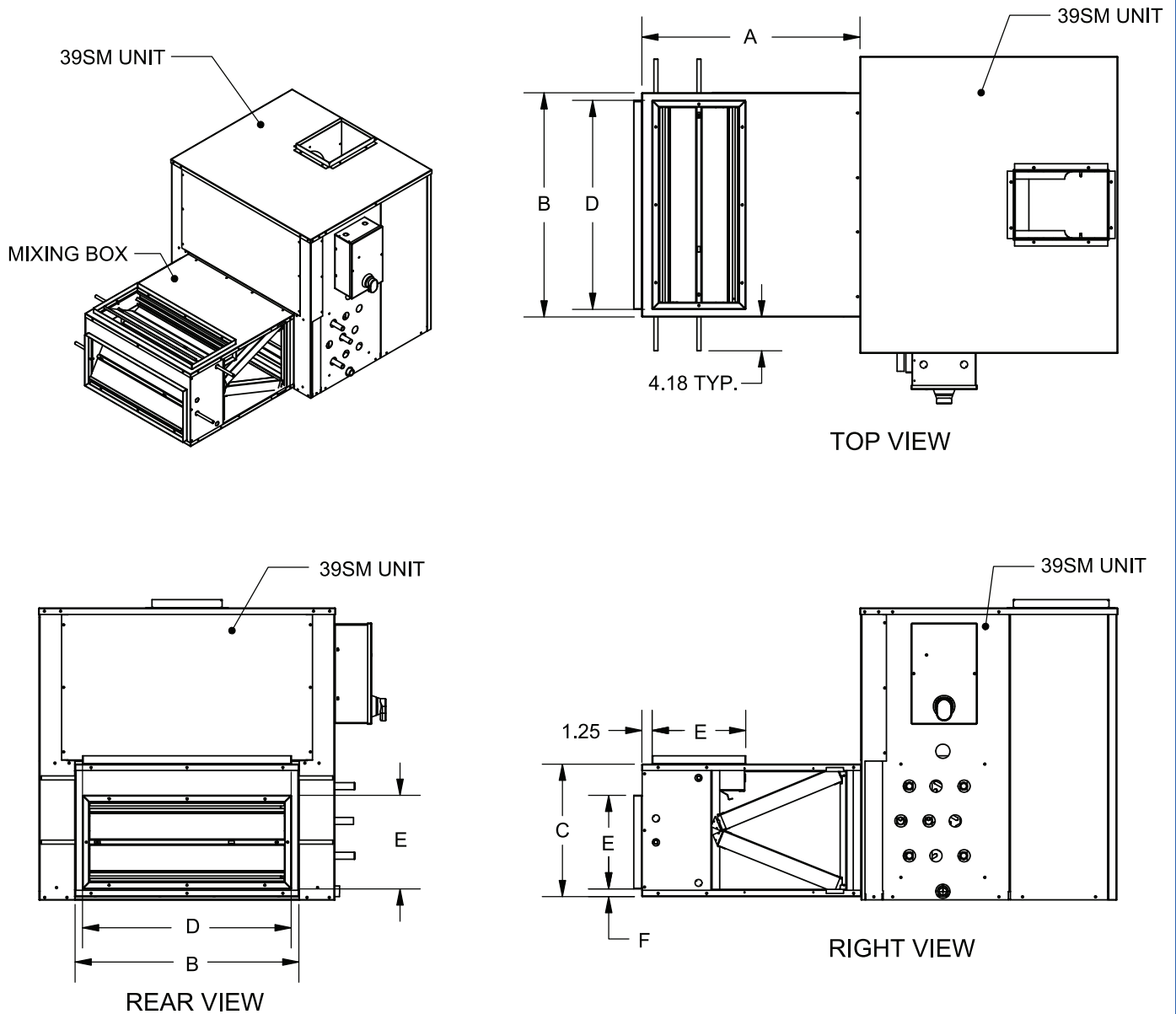

### DIMENSIONS (in.)

39SM UNIT SIZE	LENGTH	WIDTH	HEIGHT	DUCT WIDTH	DUCT HEIGHT	TOP CLEARANCE	FILTERS	
	A	B	C	D	E	F	SIZE	QTY
04,05	27.0	36.2	25.5	34.3	15.0	2.0	16 x 32 x 2	2
07,09	32.0	48.2	32.4	46.3	15.0	9.7	20 x 24 x 2	4
13,17	40.0	66.2	45.0	64.3	16.0	15.5	30 x 20 x 2	6

#### NOTES:

1. Dimensions shown in inches.
2. 39SM unit shown for reference only.
3. Not all components shown for clarity.
4. Optional actuator not shown.
5. Top and rear inlets shown. Bottom and rear inlets are also available.

### 39SR UNIT — SINGLE WALL

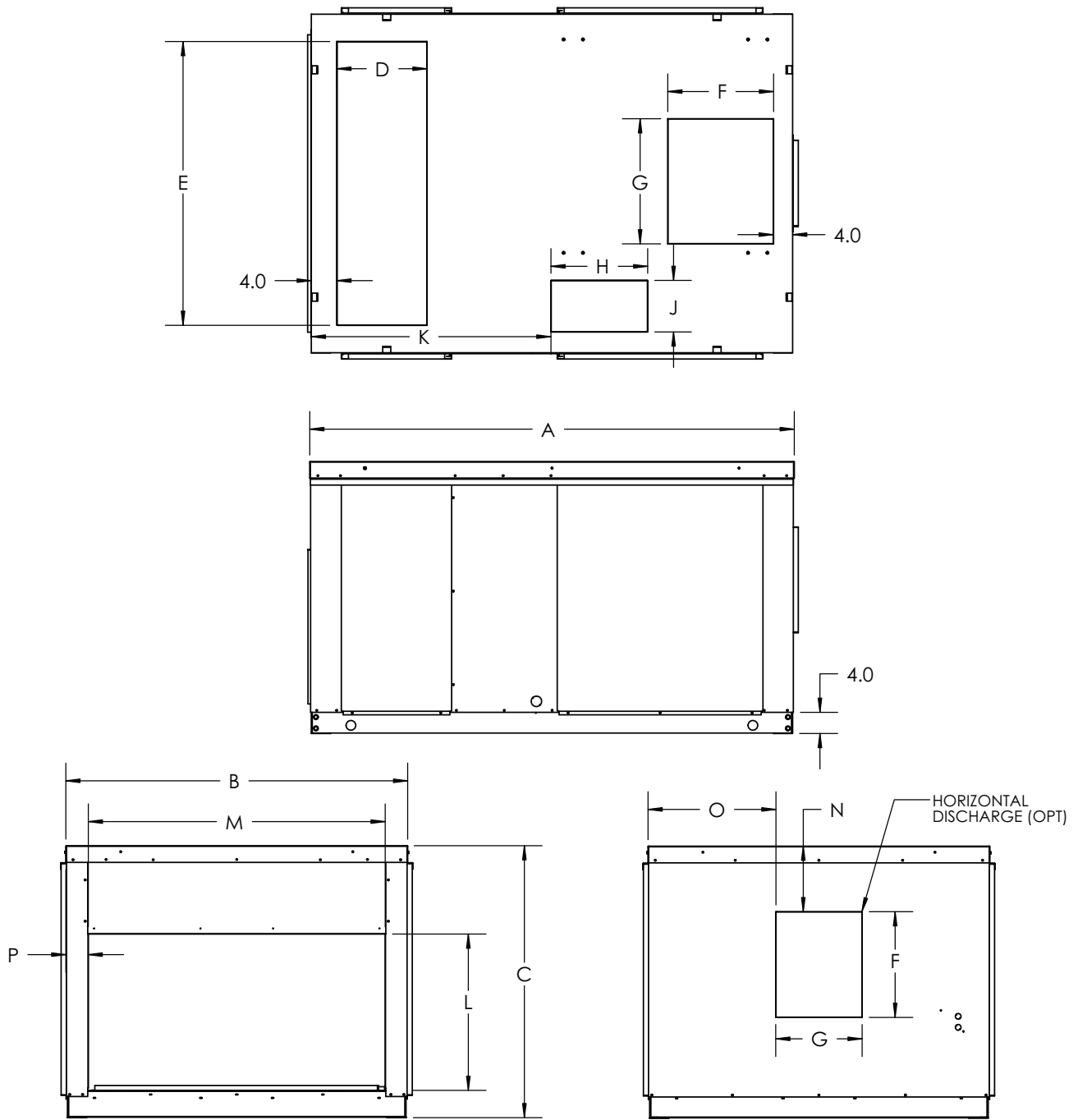

**DIMENSIONS (in.)**

39SR UNIT SIZE	A	B	C	D	E	F	G	H	J	K	L	M	N	O	P
02, 03	67.4	39.6	22.5	12.0	25.8	11.9	8.9	11.0	8.0	35.4	14.2	28.4	2.5	15.3	5.6
04, 05	72.1	48.1	28.5	12.0	34.0	14.1	13.1	11.0	8.0	35.6	18.2	35.8	5.1	17.5	6.2
07, 09	75.0	53.0	42.2	14.0	44.0	16.4	12.1	15.0	8.0	37.2	24.3	46.0	10.1	20.5	3.5
13	75.1	53.0	55.7	14.0	44.0	16.4	19.4	15.0	8.0	37.3	32.7	46.0	23.5	16.8	3.5
17	96.0	76.3	53.3	15.0	62.0	19.6	22.0	15.0	8.0	50.3	47.0	68.2	17.4	27.1	4.1

NOTE: Dimensions shown in inches.

## 39SR UNIT — DOUBLE WALL

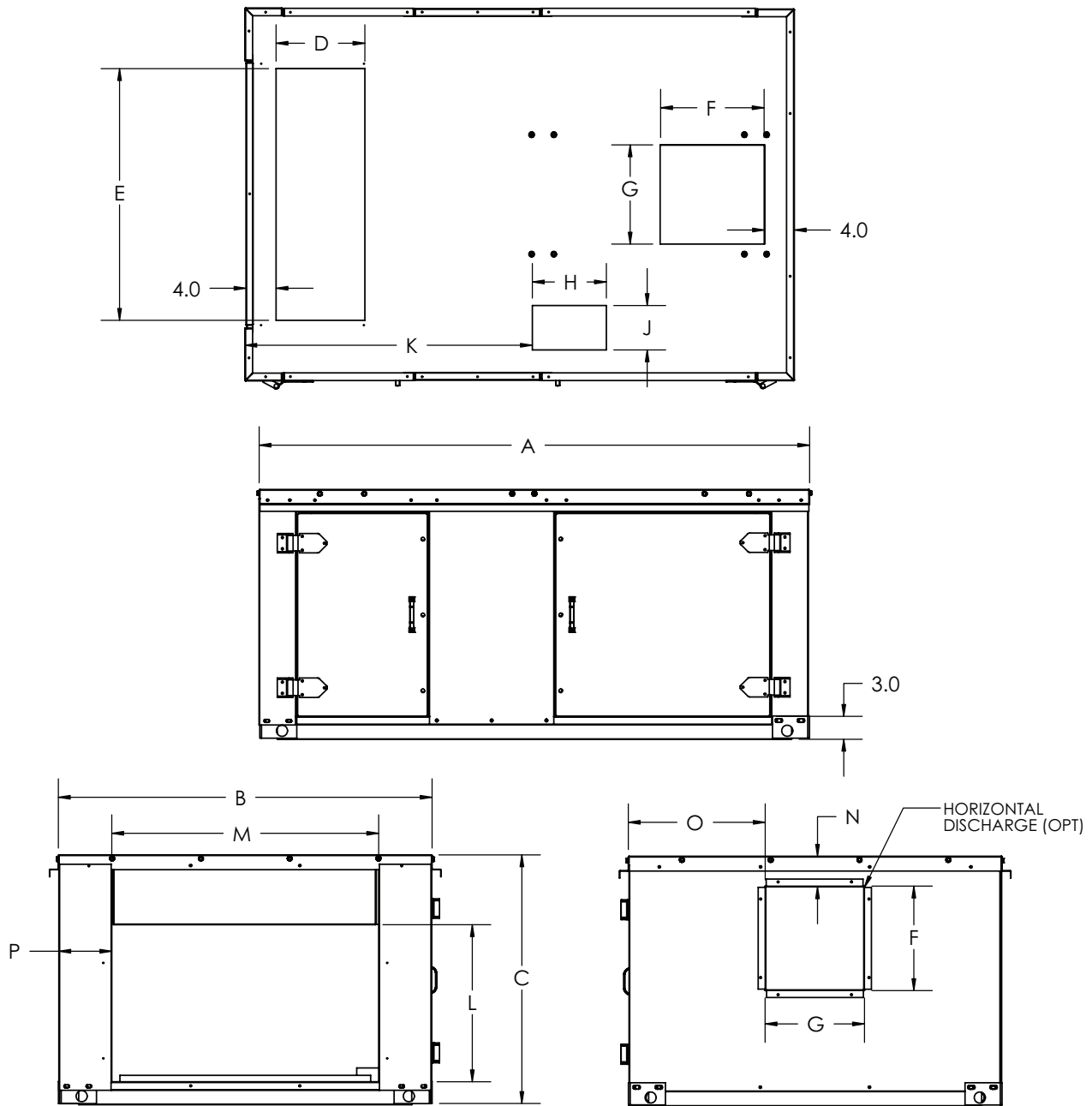

**DIMENSIONS (in.)**

39SR UNIT SIZE	A	B	C	D	E	F	G	H	J	K	L1	L2	M	N	O	P
02, 03	70.0	42.0	30.5	12.0	26.0	11.9	8.9	10.0	6.0	33.7	17.2	14.2	28.1	8.5	16.6	7.0
04, 05	70.4	50.5	33.6	12.0	34.0	14.1	13.4	10.0	6.0	38.9	21.2	18.2	36.1	4.2	18.6	7.2
07, 09	77.4	55.5	50.9	14.0	44.0	16.4	13.1	15.0	8.0	38.0	35.1	24.3	45.9	19.9	21.2	4.8
13	77.4	55.5	60.6	14.0	44.0	16.4	18.9	15.0	8.0	38.0	48.9	32.8	45.9	29.7	18.3	4.8
17	96.5	76.5	64.1	14.0	62.0	19.0	22.0	15.0	8.0	51.9	48.2	46.9	65.8	24.0	27.3	5.4

**NOTES:**

1. Dimensions shown in inches.
2. L1 dimension is for horizontal or bottom return economizer package option.
3. L2 dimension is for fixed air or manual outside air damper package option.

### 39SR UNIT — HORIZONTAL RETURN ECONOMIZER PACKAGE

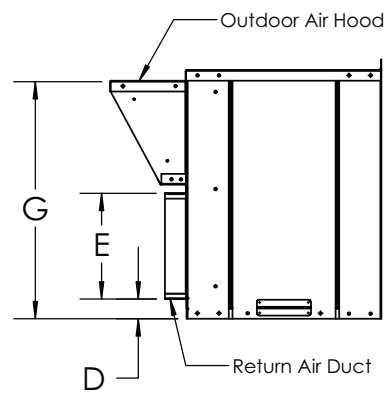
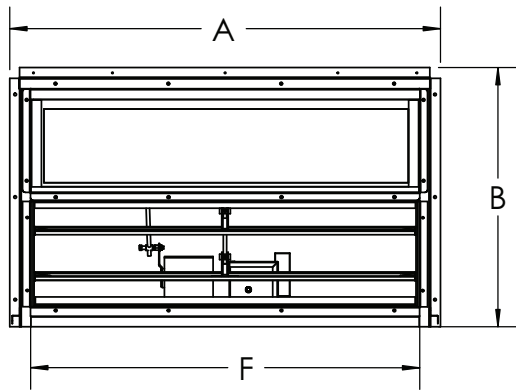
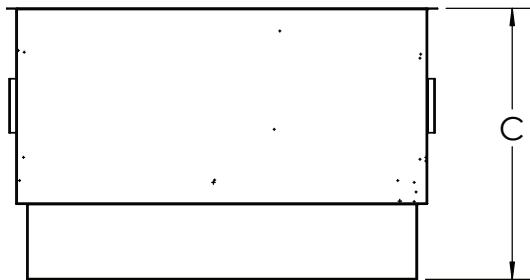
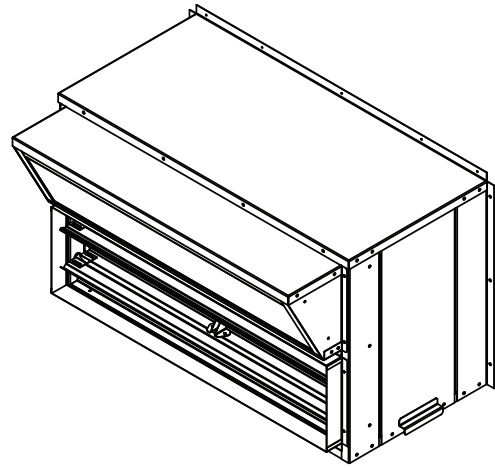

#### DIMENSIONS (in.)

39SR UNIT SIZE	A	B	C	D	E	F	G
02, 03	30.6	19.9	26.1	2.0	7.7	26.2	17.9
04, 05	39.9	18.0	25.0	1.8	9.9	35.9	22.1



## 39SR UNIT — BOTTOM RETURN ECONOMIZER PACKAGE

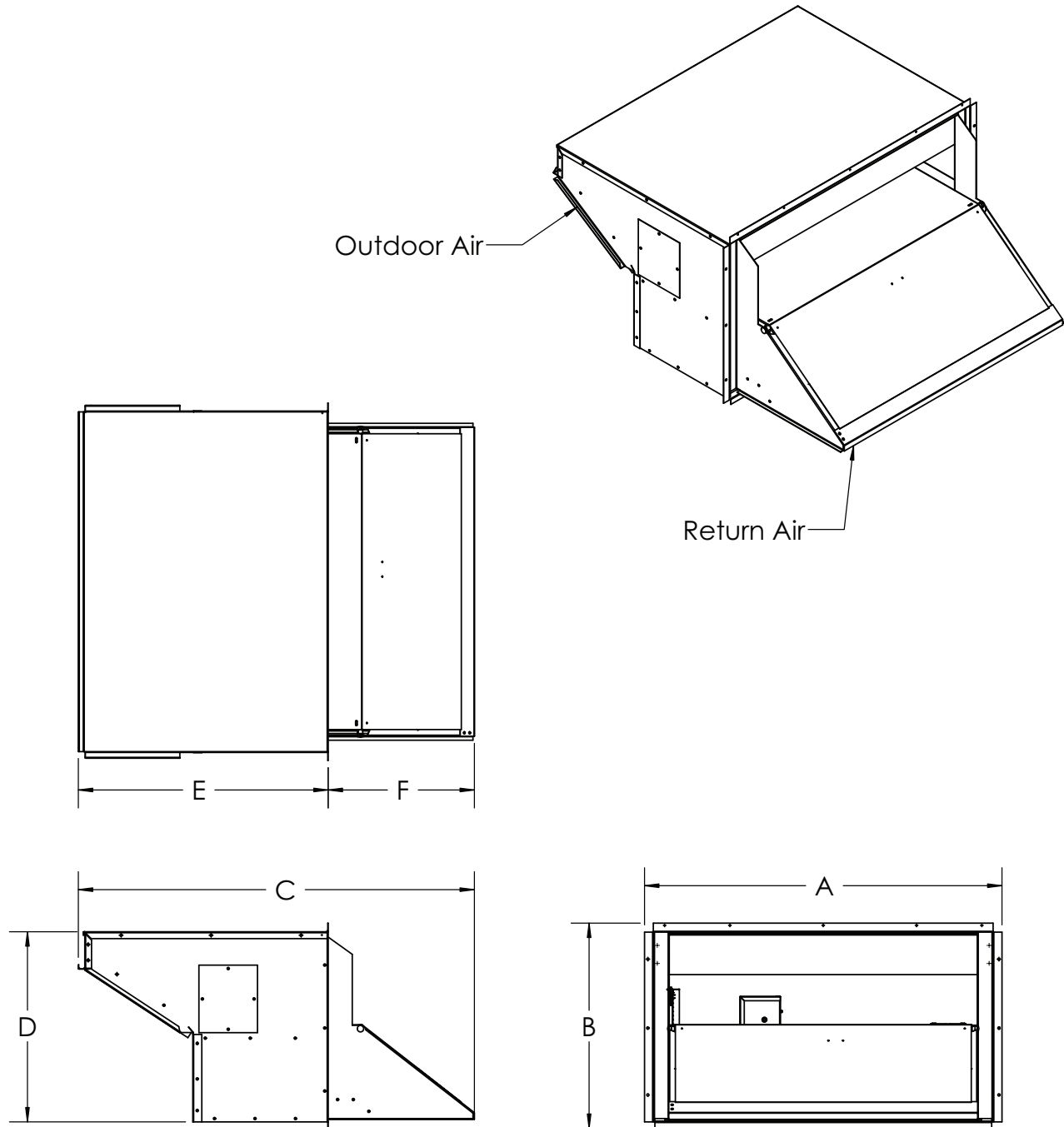

**DIMENSIONS (in.)**

39SR UNIT SIZE	A	B	C	D	E	F
02, 03	32.100	18.940	42.075	17.260	25.950	16.150
04, 05	39.725	22.825	44.025	21.125	27.750	16.250

**39SR UNIT — BOTTOM AND HORIZONTAL RETURN ECONOMIZER PACKAGE**

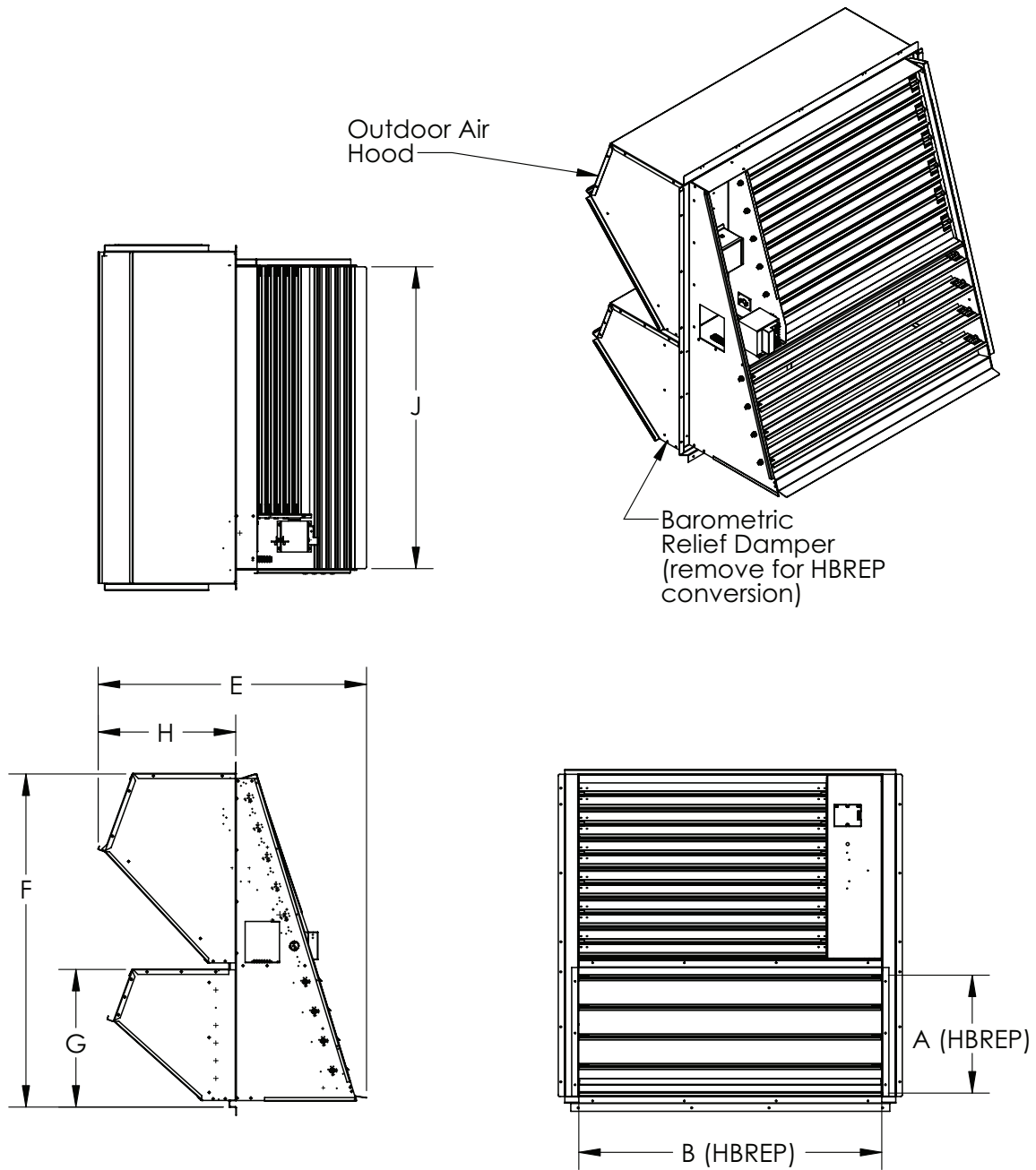

**DIMENSIONS (in.)**

39SR UNIT SIZE	A	B	E	F	G	H	J
07, 09	13.8	44.1	35.2	34.9	15.4	16.5	48.3
13	18.8	44.1	39.0	48.6	20.1	20.0	48.3
17	19.0	62.9	43.4	45.1	20.1	20.0	66.1

**LEGEND**

**HBREP**—Horizontal Return Economizer Package

## 39SR UNIT — FIXED AIR DAMPER/MOTORIZED OUTSIDE AIR DAMPER

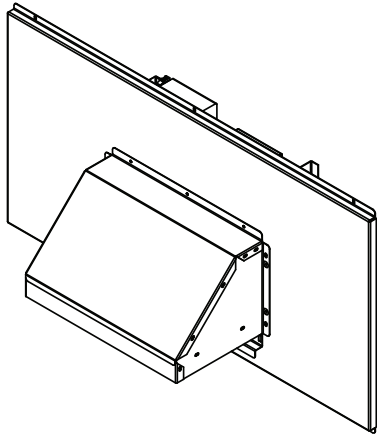

REAR ISOMETRIC VIEW

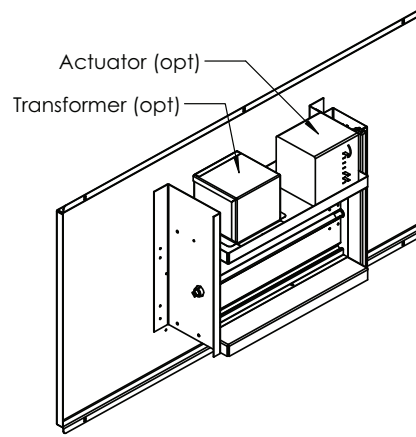

FRONT ISOMETRIC VIEW

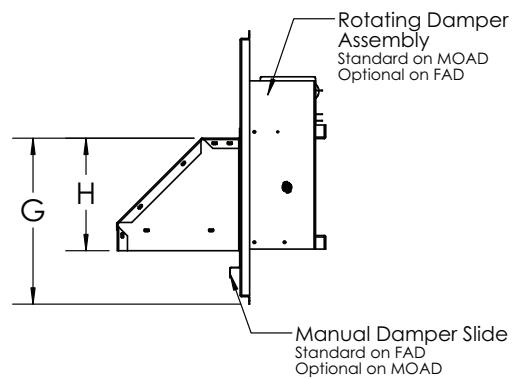
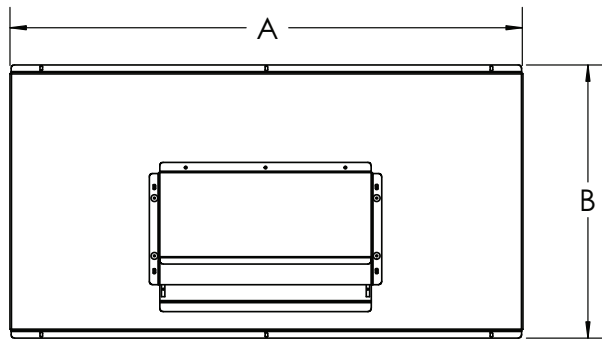
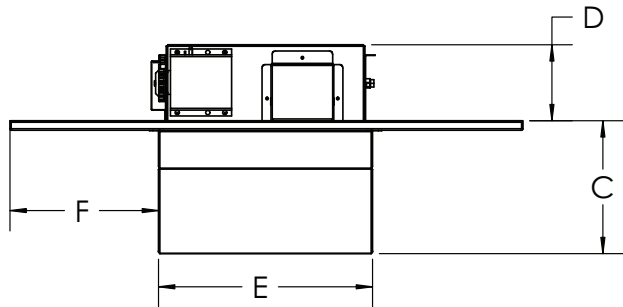

### FIXED AIR DAMPER DIMENSIONS (in.)

39SR UNIT SIZE	A	B	C	D	E	F	G	H
02, 03	28.8	16.1	10.7	5.6	10.3	9.3	12.9	10.1
04, 05	37.8	20.1	9.8	5.6	15.8	11.0	12.2	8.3
07, 09	48.8	26.9	14.5	5.6	25.3	11.8	17.6	14.1
13	48.8	34.9	19.4	5.6	21.8	13.5	23.2	19.8
17	30.3	46.8	18.8	5.6	25.3	2.5	32.9	19.8

### MOTORIZED OUTSIDE AIR DAMPER DIMENSIONS (in.)

39SR UNIT SIZE	A	B	C	D	E	F	G	H
02, 03	29.9	19.1	8.7	5.6	24.1	2.9	13.4	10.4
04, 05	37.8	23.5	14.6	5.6	25.3	6.3	17.3	13.8
07, 09	48.8	28.4	17.4	5.6	44.4	2.2	21.8	19.6
13	48.8	34.9	22.3	5.6	40.5	4.1	28.3	25.8
17	30.3	46.8	25.0	5.6	25.2	2.5	38.9	31.8

#### LEGEND

**FAD** — Fixed Air Damper  
**MOAD** — Motorized Outside Air Damper

## 39SHK, SHC, SHF COIL AND FILTER DATA

39SH UNIT SIZE	00	01	02	03	04	05	06†	07*	09*	13*	17*
<b>CHILLED WATER</b>											
Nominal Capacity at 400 fpm (cfm)	632	716	800	1224	1612	2000	2492	2916	3832	5500	7084
Face Area (sq ft)	1.58	1.79	2	3.06	4.03	5	6.23	7.29	9.58	13.75	17.71
Coil Connection Size (in. OD sweat)											
4 Row (Qty)	3/4	3/4	3/4	3/4	7/8	1 1/8	1 3/8	1 1/8	1 3/8	1 3/8	1 5/8 (2)
6 Row (Qty)	3/4	3/4	3/4	7/8	1 1/8	1 1/8	1 3/8	1 3/8	1 5/8	1 5/8	1 5/8 (2)
<b>HOT WATER</b>											
Nominal Capacity at 400 fpm (cfm)	632	716	624	956	1612	2000	2220	2688	3544	5348	6640
Face Area (sq ft)	1.58	1.79	1.56	2.39	4.03	5	5.55	6.72	8.86	13.37	16.6
Coil Connection Size (in. OD sweat)											
1 Row	5/8	5/8	5/8	5/8	7/8	7/8	1 1/8	N/A	N/A	N/A	N/A
2 Row (Qty)	7/8	7/8	7/8	7/8	7/8	1 1/8	1 1/8	1 1/8	1 3/8	1 3/8	1 5/8 (2)
4 Row** (Qty)	3/4	3/4	3/4	3/4	7/8	1 1/8	1 1/8	1 1/8	1 3/8	1 3/8	1 5/8 (2)
6 Row** (Qty)	3/4	3/4	3/4	7/8	1 1/8	1 1/8	1 1/8	1 3/8	1 5/8	1 5/8	1 5/8 (2)
<b>DIRECT EXPANSION</b>											
Nominal Capacity at 400 fpm (cfm)	476	716	800	1224	1612	2000	2432	2864	4088	5500	6640
Face Area (sq ft)	1.19	1.79	2.00	3.06	4.03	5	6.08	7.16	10.22	13.75	16.6
Connection Size (in. OD sweat) (Qty)											
Liquid Line	3/8	3/8	3/8	3/8	3/8	5/8	1/2	5/8††, 1/2*** (2)	5/8††, 1/2*** (2)	1/2*** (2)	5/8*** (2)
Suction Line	5/8	5/8	3/4	3/4	3/4	1 1/8	7/8	1 1/8††, 7/8*** (2)	1 3/8††, 7/8*** (2)	1 1/8*** (2)	1 3/8*** (2)
<b>STEAM</b>											
Nominal Capacity at 400 fpm (cfm)	632	716	752	1144	1452	1800	N/A	2688	3640	5512	7000
Face Area (sq ft)	1.58	1.79	1.88	2.86	3.63	4.5		6.72	9.1	13.78	17.5
<b>FILTER DATA</b>											
2-in. Pleated MERV 8 Size (in.) (Qty)	12x25*/12x29†	12x25*/12x29†	16x32*/12x35†	16x32*/12x35†	20x20 (2)*/18x44†	20x20 (2)*/18x44†	18x44	16x32 (2)/20x32 (1)	16x32 (2)/20x32 (1)	20x25 (2)/20x20 (4)	16x20 (2)/16x25 (2)/20x20 (2)/20x25 (2)
Nominal Face Area (sq ft)	2.08/2.42	2.08/2.43	3.56/2.92	3.56/2.93	5.56/ 5.50	5.56/ 5.50	5.50	11.56	11.56	18.06	22.5
4-in. Pleated MERV 13 Size (in.) (Qty)†	12x29	12x29	12x35	12x35	18x44	18x44	18x44	N/A	N/A	N/A	N/A
Nominal Face Area (sq ft)	2.42	2.42	2.92	2.92	5.50	5.50	5.50	N/A	N/A	N/A	N/A
12-in. HEPA Type A, 99.975%lb., 3µm Size (in.) (Qty)†	12.5x25x11.5	12.5x25x11.5	12.5x31x11.5	12.5x31x11.5	18x40x11.5	18x40x11.5	18x40x11.5	N/A	N/A	N/A	N/A
Nominal Face Area (sq ft)	2.17	2.17	2.69	2.69	5.14	5.14	5.14	N/A	N/A	N/A	N/A

\*Only 39SHK.

†Only 39SHC, SHF.

\*\*4 and 6 row hot water coils have the same face area as 4 and 6 row chilled water coils.

††Single circuited coil.

\*\*\*Dual circuited coil.

## 39SV COIL AND FILTER DATA

39SV UNIT SIZE	02	03	04	05	07	09
<b>CHILLED WATER</b>						
Nominal Capacity at 400 fpm (cfm)	1200	1200	1600	2000	2932	3668
Face Area (sq ft)	3	3	4	5	7.33	9.17
Coil Connection Size (in. OD sweat)	3/4	3/4	7/8	1 1/8	1 1/8	1 3/8
<b>HOT WATER</b>						
Nominal Capacity at 400 fpm (cfm)	804	804	964	1276	2292	3124
Face Area (sq ft)	2.01	2.01	2.41	3.19	5.73	7.81
Coil Connection Size (in. OD sweat)	7/8	7/8	7/8	1 1/8	1 1/8	1 1/8
<b>DIRECT EXPANSION</b>						
Nominal Capacity at 400 fpm (cfm)	1200	1200	1600	2000	2932	3668
Face Area (sq ft)	3	3	4	5	7.33	9.17
Connection Size (in. OD sweat) (Qty)						
Liquid Line	3/8	3/8	1/2	1/2	5/8	1/2 (2)
Suction Line	3/4	3/4	7/8	1 1/8	1 1/8	7/8 (2)
<b>STEAM</b>						
Nominal Capacity at 400 fpm (cfm)	624	624	688	1268	1750	2452
Face Area (sq ft)	1.56	1.56	1.72	3.17	4.375	6.13
<b>FILTER DATA</b>						
Size (in.) (Qty)	20x20	20x20	22.5x22.5	16x25 (2)	20x25 (4)	20x25 (4)
Nominal Face Area (sq ft)	2.78	2.78	3.52	5.56	13.89	13.89

## 39SM COIL AND FILTER DATA

39SM UNIT SIZE	04	05	07	09	13	17
<b>CHILLED WATER</b>						
Nominal Capacity at 400 fpm (cfm)	1668	2084	2776	3332	5000	7084
Face Area (sq ft)	4.17	5.21	6.94	8.33	12.5	17.71
Coil Connection Size (in. OD sweat)						
4 Row (Qty)	7/8	1 1/8	1 1/8	1 3/8	1 3/8	1 5/8 (2)
6 Row (Qty)	1 1/8	1 1/8	1 3/8	1 5/8	1 5/8	1 5/8 (2)
<b>HOT WATER</b>						
Nominal Capacity at 400 fpm (cfm)	1668	2084	2776	3332	5000	7084
Face Area (sq ft)	4.17	5.21	6.94	8.33	12.5	17.71
Coil Connection Size (in. OD sweat)						
2 Row (Qty)	7/8	1 1/8	1 1/8	1 1/8	1 1/8	1 1/8 (2)
4 Row* (Qty)	7/8	1 1/8	1 1/8	1 3/8	1 3/8	1 5/8 (2)
6 Row* (Qty)	1 1/8	1 1/8	1 3/8	1 5/8	1 5/8	1 5/8 (2)
<b>DIRECT EXPANSION</b>						
Nominal Capacity at 400 fpm (cfm)	1668	2000	2668	3332	5000	7000
Face Area (sq ft)	4.17	5	6.67	8.33	12.5	17.5
Connection Size (in. OD sweat)						
Liquid Line	1/2	1/2	5/8	5/8	5/8	5/8 (2)
Suction Line	7/8	1 1/8	1 1/8	1 3/8	1 3/8	1 5/8 (2)
<b>STEAM</b>						
Nominal Capacity at 400 fpm (cfm)	1492	1960	2472	3028	4752	6700
Face Area (sq ft)	3.73	4.9	6.18	7.57	11.88	16.75
<b>FILTER DATA</b>						
Size (in.) (Qty)	20x25 (2)	20x25 (2)	16x25 (4)	16x25 (4)	16x20 (2) 20x20 (2) 16x25 (2)	16x20 (2) 20x20 (2) 16x25 (2)
Nominal Face Area (sq ft)	6.94	6.94	11.11	11.11	22.5	22.5

\*4 and 6 row hot water coils have the same face area as 4 and 6 row chilled water coils.

### 39SR COIL AND FILTER DATA

39SR UNIT SIZE	02	03	04	05	07	09	13	17
<b>CHILLED WATER</b>								
Nominal Capacity at 400 fpm (cfm)	800	1224	1612	2000	3252	3792	5124	7000
Face Area (sq ft)	2	3.06	4.03	5	8.13	9.48	12.81	17.5
Coil Connection Size (in. OD sweat)								
4 Row	3/4	3/4	7/8	1 1/8	1 3/8	1 3/8	1 3/8	1 3/8
6 Row	3/4	7/8	1 1/8	1 1/8	1 5/8	1 5/8	1 5/8	1 5/8
<b>HOT WATER</b>								
Nominal Capacity at 400 fpm (cfm)	624	956	1612	2000	3252	3792	5124	7000
Face Area (sq ft)	1.56	2.39	4.03	5	8.13	9.48	12.81	17.5
Coil Connection Size (in. OD sweat)								
2 Row	5/8	7/8	7/8	1 1/8	1 1/8	1 1/8	1 3/8	1 1/8
4 Row*	3/4	3/4	7/8	1 1/8	1 3/8	1 3/8	1 3/8	1 3/8
6 Row*	3/4	7/8	1 1/8	1 1/8	1 5/8	1 5/8	1 5/8	1 5/8
<b>DIRECT EXPANSION</b>								
Nominal Capacity at 400 fpm (cfm)	800	1224	1612	2000	3252	3792	5124	7000
Face Area (sq ft)	2	3.06	4.03	5	8.13	9.48	12.81	17.5
Connection Size (in. OD sweat) (Qty)								
Liquid Line	3/8	3/8	1/2	1/2	5/8	5/8	7/8 (2)	7/8 (2)
Suction Line	3/4	3/4	7/8	1 1/8	1 1/8	1 3/8	1 3/8 (2)	1 5/8 (2)
<b>STEAM</b>								
Nominal Capacity at 400 fpm (cfm)	752	1144	1452	1800	3088	3576	4956	6768
Face Area (sq ft)	1.88	2.86	3.63	4.5	7.72	8.94	12.39	16.92
<b>FILTER DATA</b>								
Single Wall Unit, Throwaway Filter Size (in.) (Qty)	16x32	16x32	20x20 (2)	20x20 (2)	16x25 (4)	16x25 (4)	16x20 (3) 16x25 (3)	16x20 (4) 16x25 (4)
Nominal Face Area (sq ft)	3.56	3.56	5.56	5.56	11.11	11.11	15	20
Single Wall Unit, Pleated Filter Size (in.) (Qty)	16x32	16x32	20x24 (1) 16x20 (1)	20x24 (1) 16x20 (1)	16x25 (4)	16x25 (4)	16x20 (3) 16x25 (3)	16x20 (4) 16x25 (4)
Nominal Face Area (sq ft)	3.56	3.56	5.56	5.56	11.11	11.11	15	20
Double Wall Unit, Pleated and Throwaway Filters Size (in.) (Qty)	16x32 (1) 10x10 (3)	16x32 (1) 10x10 (3)	12x25 (1) 12x20 (1) 16x20 (1) 16x25 (1)	12x25 (1) 12x20 (1) 16x20 (1) 16x25 (1)	25x25 (2) 20x25 (2)	25x25 (2) 20x25 (2)	16x24 (3) 29x48 (1)	16x20 (4) 16x32 (4)
Nominal Face Area (sq ft)	5.64	5.64	8.75	8.75	15.63	15.63	17.67	23.11

\*4 and 6 row hot water coils have the same face area as 4 and 6 row chilled water coils.

## Indoor and Outdoor Air Handlers

### HVAC Guide Specifications

Size Range: **400 to 8,500 Nominal Cfm**

Carrier Model Numbers: **39SH,SV,SM,SR**

#### Part 1 — General

##### 1.01 SYSTEM DESCRIPTION

- A. Central station air handler designed to provide air to a conditioned space as required to meet specified performance requirements for ventilation, heating, cooling, filtration and distribution. Unit shall be assembled for draw-thru applications and blow-thru applications with HEPA filtration and shall be arranged to discharge conditioned air horizontally or vertically as shown on the contract drawings.
- B. Unit with a direct-expansion cooling coil shall have the capability to be used in a refrigerant circuit in conjunction with air-cooled condensing units.

##### 1.02 QUALITY ASSURANCE

- A. Unit performance shall be rated in accordance with AHRI (Air-Conditioning, Heating and Refrigeration Institute) Standard 430 for Central Station Air-Handling Units and subject to verification of rating accuracy by AHRI-sponsored, third party testing.
- B. Coils shall be designed to comply with AHRI Standard 410.
- C. Direct expansion coils shall be designed and tested in accordance with ANSI/ASHRAE (American National Standards Institute/American Society of Heating, Refrigerating, and Air-Conditioning Engineers) 15 Safety Code for Mechanical Refrigeration, latest edition.
- D. Unit shall be constructed in accordance with ETL and ETL, Canada, standards and shall carry the ETL and ETL, Canada, labels.

##### 1.03 DELIVERY, STORAGE AND HANDLING

Unit shall be stored and handled in accordance with the unit manufacturer's instructions.

#### Part 2 — Products

##### 2.01 EQUIPMENT

###### A. General:

Unit shall be a factory-assembled central station air handler. Unit may consist of a fan and coil section with factory-installed chilled water or direct expansion coil, preheat or reheat coil, heating coil section, filter section, and/or mixing box as indicated on the equipment schedules.

###### B. Unit Cabinet:

1. External panels shall have a minimum thickness of 20 gage galvanized steel and are to be covered with a polyurethane based powder coat. Internal parts are to be built from heavy gage galvanized steel.
2. Units shall pass 500-hour salt spray test as described in ASTM (American Society for Testing and Materials) B-117.

3. Large access panels shall be provided to permit full access to internal components. The structural integrity of the cabinets shall remain unaffected by the removal of any or all access panels. Double-walled hinged access doors shall be available on double-walled outdoor units.

4. 39SR, 39SHC, and 39SHF unit panels shall have 2 layers of insulation with 22-ga sheet metal liner.

5. Condensate drain pans shall be constructed of either plastic, galvanized steel or stainless steel.

6. Internal pipe chase for coil piping in 39SR units.

7. Optional anti-microbial powder coating, passing a 750-hour salt spray test, on 39SHC and 39SHF units.

###### C. Insulation:

Insulation shall have a minimum thickness of  $\frac{3}{4}$  inch.

1. 39SH and 39SV units with double-wall finish shall have Exact-O-Kote\* IAQ insulation between the inner and outer panels while double-wall 39SR panels shall contain Tuf-Skin\* insulation. Double-wall finish shall not be available on 39SM units.

2. Closed cell foam insulation shall be a flexible, polymer based, low density, closed cell, chemically inert foam sheet insulation. Density of closed cell foam insulation shall be 1.5 lb per cubic foot.

3. Indoor air quality (IAQ) insulation shall be fiberglass insulation with an acrylic coating. Coating is formulated with an immobilized EPA (Environmental Protection Agency) registered, anti-microbial agent to protect against microbial growth.

4. Tuf-Skin II insulation shall be dual density fiberglass insulation that has a high density skin and a low density core.

5. Insulation and adhesive shall meet NFPA (National Fire Protection Association) 90A requirements for flame spread and smoke generation.

###### D. Fan Section:

1. Fan housing shall be constructed of heavy gage steel with die-formed inlet cones.

2. Fans shall be double width, double inlet type, with forward-curved blades, centrifugal type.

3. The 39SHC and 39SHF units shall be equipped with direct drive plenum fans. Fans shall be backward curved, galvanized steel, painted, with fixed hub.

4. The 39SHC and 39SHF units are equipped with a rubberized canvas inlet collar assembly and rubber-in-shear vibration isolators.

5. Fans shall be statically and dynamically balanced.

\*Exact-O-Kote and Tuf-Skin are trademarks of Johns Manville, Inc.



6. The fan shaft shall be solid cold rolled steel designed such that its operating speed is below its first critical speed.
7. Fan bearings shall be rubber mounted, self aligning, sealed cartridge, permanently lubricated ball bearings and shall provide dependable fan operation for an average life of 200,000 hours.
8. Fans on 39SH, SV, and SR units shall be internally isolated with rubber grommets.
9. Fan motor shall be standard duty, single speed, 1750 rpm, single or 3-phase 60 Hz, suitable for continuous duty at 104 F (40 C) in 115, 208, 230, 277 v. Three-phase motors shall be available in 208, 230, or 460 v. 39SM and 39SR unit single-phase motors shall be provided with resilient mount. The 39SV unit motors shall be provided with resilient mount and automatic reset thermal overload protection. Fan motors have open drip-proof construction. Fan motors shall be bolted to an adjustable platform to facilitate belt tension and alignment. Motors shall be NEMA (National Electrical Manufacturers Association) B,T-frame design.
10. The 39SHC and 39SHF units shall be equipped with a direct drive plenum fan motor of open drip proof (ODF) construction. Motors shall be single speed, 60 Hz, 3600 rpm, suitable for continuous duty at 104 F. Single phase motor available in 115, 208, 230, or 277 volts. Three phase motors are available in 208, 230, or 460 volts. Motors are NEMA-premium and rated for use with VFD. Three phase motors in 575 volt (60 Hz), as available.
11. Units shall be provided with ETL listed motor start/stop station (MSS) with 24-v transformers, terminal strips, and interlocking on/off switch with lockout/tagout capability (39SM units) or disconnect switch (39SV units). Motors without thermal overload shall have motor starters with overload protection. The MSS is not available with 2-speed motors or 39SH units with electric heat.
12. Drive shall be of the V-belt type. Variable pitch motor sheaves are to be furnished for ease and accuracy in balancing the system and adjusting the required air volume. The blower sheave shall be cast iron single groove with split tapered bushing that is keyed to the blower shaft.
13. Variable frequency drive (VFD) is pre-programmed to protect motor from over-current and to allow field supplied fan speed control signal via 0 to 10 VDC input on VFD.

#### E. Coils:

1. Coils shall be of the staggered tube type constructed with seamless copper tubes and headers, and deep corrugated aluminum fins with

straight edges. Manufacturer shall supply full depth collars, drawn in the fin stock to provide accurate control of fin spacing and completely cover the copper tubes to lengthen coil life. The tubes are to be mechanically expanded into the fins for a permanent primary to secondary surface bond, assuring maximum heat transfer efficiency. Coils for 39SR, 39SV, and 39SH units shall be factory leak tested at 400 psig air pressure, and 39SM units shall be tested at 450 psig air pressure.

2. Steam coils shall be inner distributing tube (IDT) construction.
3. 39SM units shall allow a maximum of 10 total rows between heating and cooling coils. 39SR units shall have a maximum of 8 total rows. 39SHC and 39SHF units shall have a maximum of 12 total rows.
4. Hydronic coils shall be equipped with a mechanical air vent. Manual air vents are not provided with the 39SHC and 39SHF units. Air removal is the responsibility of the installer.
5. Heat pump conversion kit available for field mounting on 39SM, 39SR and 39SHK units.
6. 39SV units are standard left hand (looking at front of unit) to include chilled water coil stubouts and electrical and drain connections.

#### F. Electric Heaters:

1. Electric heaters shall have automatic resets for primary protection and manual resets for secondary protection.
2. There shall be circuit fusing on heaters over 48 amps per UL (Underwriters Laboratories) and NEC (National Electrical Code).
3. Electric heater plenum section shall be made of minimum 20 gauge steel.
4. Heater shall have a standard 24-vac NEMA (National Electrical Manufacturers Association) 1 control panel with hinges and automatic latch-on cover.
5. Heater shall have a standard 24-vac control circuit and class 2 transformer.
6. Air pressure switch frames shall be made of sturdy galvanized steel with rugged steatite insulators and double threaded stainless steel stud bolts.
7. Heating elements shall be openwound nickel/chrome alloy supported by ceramic insulators on plated steel brackets.
8. Heater internal wiring shall be made of stranded copper wire with insulation rated for 105 C.
9. The entire heater modulates on a 0 to 10 volt DC or 4 to 20 mA control signal.
10. 240-v heaters shall be derated 25% for use in 208-v applications. 240-v heaters shall be derated 8% for use in 230-v applications.

11. 39SH electric heaters shall be tied into the unit's main power connection so as to create a single point power connection for the unit and the heater. Single point power is not available on 39SV and 39SM units with electric heat. Electric heat is not available on 39SR, 39SHC, or 39SHF units.
- G. Filter Sections:
1. Disposable filters shall be included with the unit as standard. Optional MERV 8 filters shall be available. Filters shall be included in the units as an integral part of the cabinet with easy access provided by the manufacturer.
  2. The 39SHC and 39SHF units provide 2-in. pleated MERV 8 filters or 4-in. MERV 13 pleated filters. An optional 12-in., pleated MERV 16 final HEPA filter with metal frame or 12-in. MERV 14 filter is available on the 39SHF unit only.
- H. Damper Sections:
1. Mixing boxes shall include low leak damper assemblies constructed of welded steel channel frames with 18 gage galvanized steel blades, die formed stiffeners and full blade stop. Stainless steel side seals and vinyl blade seals to reduce leakage shall be standard. All hardware shall be zinc plated with brass pivot points and bronze oilite bearings. Shafts shall be corrosion resistant steel.
  2. Mixing box shall be fully insulated with  $\frac{3}{4}$ -in. Tuf-Skin II insulation.
  3. The 39SHC and 39SHF units have a closed cell foil face.
  4. Face and bypass sections shall have opposed-acting damper blades in the face damper and opposed bypass damper. All damper blades shall be galvanized steel, housed in a galvanized steel frame rotating in bronze oilite bearings. Dampers shall be sectionalized to limit blade length so as to minimize blade warpage.
- I. Economizer Packages:
1. Economizers shall include weather hood and low-leak damper assemblies constructed of steel channel frames with 18 gage galvanized steel blades, die-formed stiffeners and full blade stop. Stainless steel side seals and vinyl blade seals to reduce leakage shall be standard. All hardware shall be zinc plated with brass pivot points and bronze oilite bearings. Shafts shall be corrosion resistant steel. Includes motor, enthalpy control, mixed air sensor and transformer relay for 208/230/1 volt units. Economizers ship separate for field assembly to unit.
  2. Manual fixed outdoor-air dampers for 0 to 35% or 0 to 100% outdoor air.
  3. Motorized fixed outdoor-air damper for 0 to 100% outdoor air.
- J. Electrical Accessories:
1. Motor start/stop station shall include a terminal strip, 24-v Class 2 transformer (75-va), motor relay, contactor, or starter and interlocking disconnect.
  2. Variable Frequency Drives available on 39SHC and 39SHF units:
    - a. Referenced Standards and Guidelines:
      - 1) Institute on Electrical and Electronic Engineers (IEEE)
        - a. IEE 519-2014, Guide for Harmonic Content and Control.
      - 2) Underwriters Laboratories (as appropriate)
        - a. UL508
        - b. UL508A
        - c. UL508C
      - 3) National Electrical Manufacturer's Association (NEMA)
        - a. ICS 7.0, AC Adjustable Speed Drives
      - 4) International Electrotechnical Commission (IEC)
        - a. EN/IEC 61800-3
      - 5) National Electric Code (NEC)
        - a. NEC 430, 120, Adjustable-Speed Drive Systems
    - b. Qualifications:
      - 1) VFDs and options shall be UL listed for Canada and US.
      - 2) CE Mark – The base VFD shall conform to the European Union Electromagnetic Compatibility directive, a requirement for CE marking.
      - 3) RoHS compliance.
      - 4) UL type enclosures tested to meet NEMA specifications.
    - c. Factory-mounted variable frequency drives (VFDs) shall be wired to factory-supplied motors.
    - d. Factory-supplied VFDs are programmed and started up from the factory and qualify the VFD, through ABB, for a 24-month warranty from date of commissioning or 30 months from date of sale, whichever occurs first.
    - e. The VFD parameters are programmed into the controller and removable keypad. In the event that the VFD fails and needs replacement, the program can then be uploaded to the replacement VFD via the original keypad.
    - f. The VFD shall provide full rated output from a line of  $\pm 10\%$  of nominal voltage. The VFD shall continue to operate without faulting in a range from +30% to -35% of nominal voltage.

- g. VFDs shall be capable of continuous full load operation under the following environmental operating conditions:
- 1) 10 to 40 °C (14 to 104 °F) ambient temperature. Operation above this range shall be possible with derate.
  - 2) Altitude 0 to 3300 feet above sea level. Operation to 6600 feet shall be allowed with a 10% reduction from VFD full load current.
  - 3) Humidity less than 95%, non-condensing.
- h. All VFDs shall have the following standard features:
- 1) All circuit boards shall be coated to protect against corrosion.
  - 2) All VFDs shall have the same customer interface, including digital display, and keypad, regardless of horsepower rating. The keypad shall be removable, capable of remote mounting and allow for uploading and downloading of parameter settings as an aid for start-up of multiple VFDs.
  - 3) The keypad shall include Hand-Off-Auto selections and manual speed control. The drive shall incorporate “bump less transfer” of speed reference when switching between “Hand” and “Auto” modes. There shall be fault reset and “Help” buttons on the keypad. The Help button shall include “on-line” assistance for programming and troubleshooting.
  - 4) There shall be a built-in time clock in the VFD keypad. The clock shall have a battery backup with 10 years minimum life span.
  - 5) The VFDs shall utilize pre-programmed application macros to facilitate start-up.
  - 6) The VFD shall have cooling fans that are designed for easy replacement.
  - 7) The VFD shall be capable of starting into a coasting load (forward or reverse) up to full speed and accelerate or decelerate to set point without tripping or component damage (flying start).
  - 8) The VFD shall have the ability to automatically restart after an over-current, over-voltage, under-voltage, or loss of input signal protective trip. The number of restart attempts, trial time, and time between attempts shall be programmable.
  - 9) The overload rating of the drive shall be 110% of its normal duty current rating for 1 minute every 10 minutes.
  - 10) The VFD shall provide a loss-of-load output based on a User Defined Load Curve. The drive shall be programmable to signal the loss-of-load condition via a keypad warning, Form-C relay output, and/or over the serial communications bus. The loss-of-load condition sensing algorithm shall include a programmable time delay that will allow for motor acceleration from zero speed without signaling a false loss-of-load condition.
- 11) The VFD shall include PID algorithms that allow the VFD to control of the motor.
- 12) If the input reference is lost, the VFD shall give the user the option of; (1) stopping and displaying a fault, (2) running at a programmable preset speed, or (3) hold the VFD speed based on the last good reference received. The drive shall be programmable to signal this condition via a keypad warning, Form-C relay output and/or over the serial communication bus.
- 13) The VFD shall have programmable “Sleep” and “Wake up” functions to allow the drive to be started and stopped from the level of a process feedback signal.
- i. All VFDs to have the following features:
- 1) Three (3) programmable critical frequency lockout ranges to prevent the VFD from operating the load continuously at an unstable speed. The lockout range must be fully adjustable, from 0 to full speed.
  - 2) Two (2) PID controllers shall be standard in the drive, allowing pressure or flow signals to be connected to the VFD, using the microprocessor in the VFD for the closed-loop control. The PID set point shall be adjustable from the VFD keypad, analog inputs, or over the communications bus. There shall be two independent parameter sets for the PID controller and the capability to switch between the parameter sets via a digital input, serial communications or from the keypad. The independent parameter sets are typically used for night setback, switching between summer and winter set points, etc.
  - 3) There shall be an independent, second PID loop that can utilize the second analog input and modulate one of the analog outputs to maintain the set point of an independent process (i.e. valves, dampers, etc.). All set points, process variables, etc. to be accessible from the serial communication network.
  - 4) Two (2) programmable Analog Inputs shall accept current or voltage signals.
  - 5) One (1) programmable Analog Outputs (0 to 20 mA or 4 to 20 mA). The outputs may be programmed to output pro-

portional to Frequency, Motor Speed, Output Voltage, Output Current, Motor Torque, Motor Power (kW), DC Bus voltage, Active Reference, Active Feedback, and other data.

- 6) Five (5) programmable Digital Inputs for maximum flexibility in interfacing with external devices. All digital inputs shall be programmable to initiate upon an application or removal of 24VDC.
  - 7) One (1) programmable, digital Form-C Relay Output.
  - 8) One (1) programmable, Digital Output. Transistor output PNP. The relay shall be rated for a maximum switching current of 100 mA at 30VDC.
  - 9) Run permissive circuit - for damper, proof of flow path prior to drive operation.
  - 10) The VFD control shall include a programmable time delay for VFD start and a keypad indication that this time delay is active.
  - 11) Seven (7) programmable preset speeds.
  - 12) Two independently adjustable ACCEL and DECEL ramps with 1 to 1800 seconds adjustable time ramps.
  - 13) The VFD shall include a carrier frequency control circuit that reduces the carrier frequency based on actual VFD temperature.
  - 14) The VFD shall include password protection against parameter changes.
- j. The keypad shall include a backlit LCD display. The display shall be in complete English words for programming and fault diagnostics. All VFD faults shall be displayed in English words. The keypad shall include programming assistants.
- k. All applicable operating values shall be capable of being displayed in engineering (user) units. A minimum of three operating values from the list below shall be capable of being displayed at all times. The display shall be in complete English words (alpha-numeric codes are not acceptable):
- 1) Output Frequency
  - 2) Motor Speed
  - 3) Motor Current
  - 4) Motor Torque
  - 5) Motor Power (kW)
  - 6) DC Bus Voltage
  - 7) Output Voltage
- l. The VFD shall include a fireman's override input DI point. The VFD shall operate at a programmed predetermined fixed speed or in a specific fireman's override PID algorithm that automatically adjusts motor speed based on override set point and feedback. The mode shall override all other inputs

(analog/digital, serial communication, and all keypad commands), except customer defined safety run interlocks, and force the motor to run in one of the two modes above. "Override Mode" shall be displayed on the keypad. Upon removal of the override signal, the VFD shall resume normal operation, without the need to cycle the normal digital input run command.

m. Serial Communications

- 1) The VFD shall have an EIA-485 port as standard. The standard protocols shall be Modbus, Johnson Controls N2, Siemens Building Technologies FLN, and BACnet. Each individual drive shall have the protocol in the base VFD. The use of third party gateways and multiplexers is not acceptable.
  - 2) The BACnet connection shall be an EIA-485, MS/TP interface operating at 9.6, 19.2, 38.4, or 76.8 Kbps. The connection shall be tested by the BACnet Testing Labs (BTL) and be BTL Listed.
  - 3) Serial communication capabilities shall include, but not be limited to; run-stop controls, speed set adjustment, and lock and unlock the keypad. The drive shall have the capability of allowing the BAS to monitor drive operating data, such, as process variable feedback, output frequency, current (in amps), % torque, power (kW), kilowatt hours (resettable), operating hours (resettable), and drive temperature. The BAS shall also be capable of monitoring the VFD relay output status, digital input status, and all analog input and analog output values. All diagnostic warning and fault information shall be transmitted over the serial communications bus. Remote VFD fault reset shall be possible.
- n. EMI/RFI filters. All VFDs shall include EMI/RFI filters. The onboard filters shall allow the VFD assembly to be CE Marked and the VFD shall meet product standard EN 61800-3 for Second environment (Category C3, C4).



