

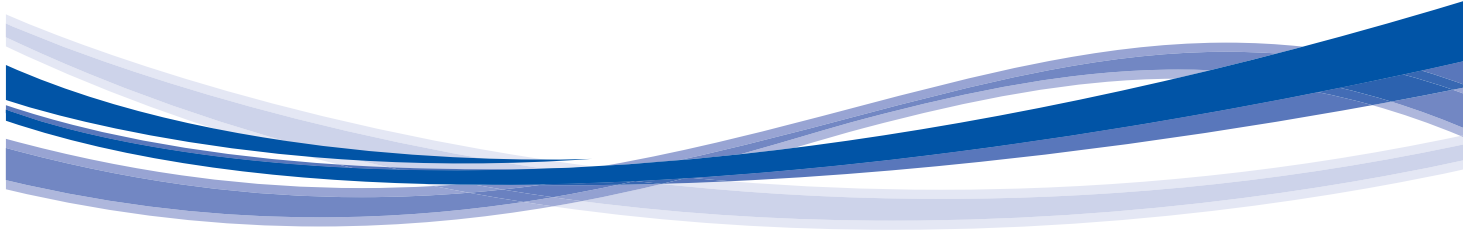

Product Data

Airstream™ Hydronic Ceiling Cassettes ¾ to 3 Nominal Tons



AIRSTREAM™

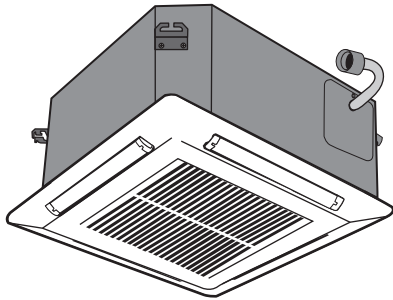

UNIT SIZES 08-12

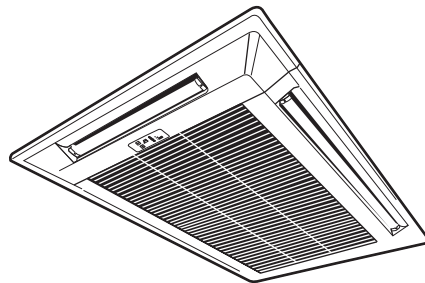

UNIT SIZES 18-36

42WKN08-36
Hydronic Ceiling Cassettes

Ceiling cassette units make each served area an independent controlled temperature zone to suit diverse requirements.

Hydronic ceiling cassette units offer:

- 6 chilled water cooling models to properly match job
- Optional electric heat or hot water coil
- Wall-mounted thermostat
- Installation cost savings through use of existing piping and/or wiring
- Low noise level construction
- Optional microprocessor based controller with infrared transmitter

Construction

Cases are constructed of lightweight galvanized sheet steel with integral fan mounting rails for added strength. Fire resistant foam insulation (rated to UL94 VO) is fitted internally to provide both thermal and acoustic insulation.

The pearl-gray fascia is constructed of high-impact polystyrene.

Chilled water coil

Units use large surface area coils positioned to optimize heat transfer and airflow. Each coil is manufactured from copper tubes with mechanically bonded aluminum fins and is circuited from headers to ensure low water pressure drops.

Fan

The backward-curved, centrifugal fans are statically and dynamically balanced for quiet operation. Fan impellers are made from either aluminum or fire-retardant plastic (UL94 VO) for lightweight and corrosion-resistant operation. Enclosed multi-speed external rotor fan motor allows good heat dissipation and increased motor efficiency. Fans come complete with thermal overload protection and sealed-for-life lubricated bearings.

Filtration

Reusable wire framed filters are fitted and may be vacuum cleaned.

Condensate pump

A condensate pump is fitted to carry water out of the unit. The pump is

fixed to a mounting bracket which can be withdrawn from the side of the chassis and incorporates an inspection hole to allow a visual check of the pump during operation. A float switch is fitted to stop the cooling action should the pump become blocked or fail.

Air vanes

Air outlet vanes are manufactured from aluminum and covered with nylon flock to prevent condensation from forming. Vanes are manually adjustable on unit sizes 08,12 and driven by an electric motor on unit sizes 18-36. Motorized air vanes can be set to auto sweep or can be stopped in a fixed position. Polystyrene blanking pieces are supplied with cassette packing so that up to two fascia discharge slots can be blanked off.

Alarm interlock relay

Alarm interlock relay includes a relay for unit failure notification. Normally open/normally closed contacts are available for field connection.

Table of contents

	Page
Features/Benefits	2
Model Number Nomenclature	3
Physical Data	4
Options and Accessories	5
Dimensions	7
Selection Procedure	10
Performance Data	11
Electrical Data	14
Typical Wiring Schematic	14
Controls	15
Guide Specifications	16

Model number nomenclature



42 SERIES HYDRONIC CEILING CASSETTES

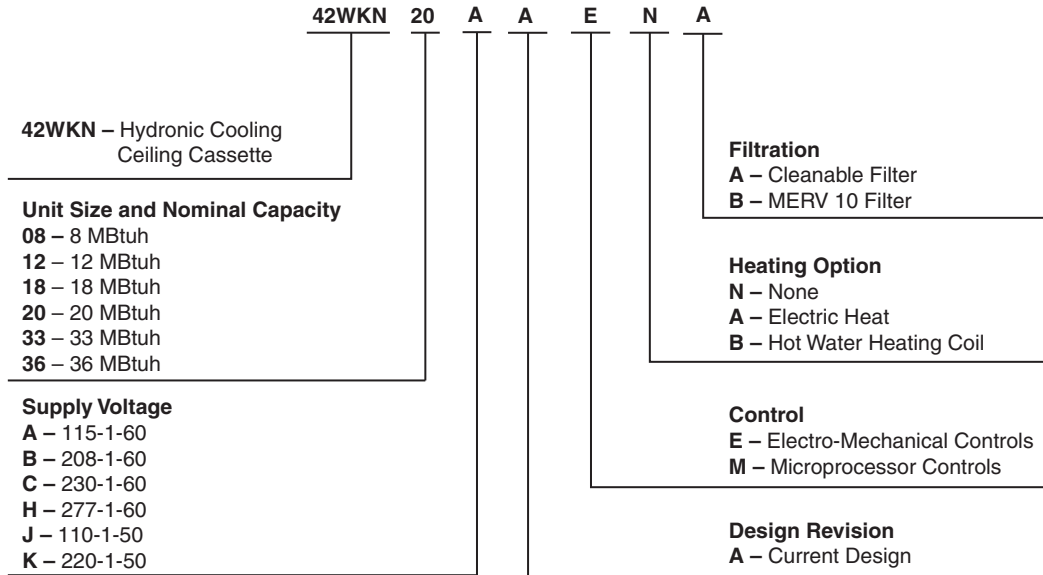

Physical data



42WKN UNIT SIZE	08	12	18	20	33	36
NOMINAL TONS	3/4	1	1 1/2	1 3/4	2 1/2	3
NOMINAL COOLING CAPACITY (Btuh)	7,800	11,200	18,200	18,600	31,100	34,300
Dimensions/Weights						
Height – Chassis/Fascia (in.) (not additive)	11 3/4 / 11 1/4	11 3/4 / 11 1/4	11 / 13 3/4	11 / 13 3/4	13 / 13 3/4	13 / 13 3/4
Width – Chassis/Fascia (in.)	22 1/2 / 25	22 1/2 / 25	32 3/8 / 37	32 3/8 / 37	45 1/2 / 49 1/4	45 1/2 / 49 1/4
Depth – Chassis/Fascia (in.)	22 1/2 / 25	22 1/2 / 25	32 3/8 / 37	32 3/8 / 37	32 3/8 / 37	32 3/8 / 37
Weight – Chassis/Fascia (lb)	40 / 5	40 / 5	64 / 18	64 / 18	97 / 21	97 / 21
Chilled Water Coil						
Type	Finned Tube					
Quantity	1	1	1	1	1	1
Face Area (sq ft)	1.8	1.8	2.8	2.8	5.2	5.2
Nominal Airflow (cfm)						
High	340	360	630	680	970	1030
Medium	300	340	550	630	850	1020
Low	260	300	490	540	740	890
Discharge	4-way	4-way	4-way	4-way	4-way	4-way
Unit Water Volume (gal)	0.29	0.29	0.45	0.45	0.79	0.79
Fan						
Type	Centrifugal					
Quantity	1	1	1	1	2	2
Diameter (in.)	12	12	15	15	14	14
Horsepower per fan (Hp)	1/8	1/8	1/6	1/6	1/6	1/6
Connections (Sweat)						
Chilled Water Inlet, OD (in.)	5/8	5/8	7/8	7/8	7/8	7/8
Chilled Water Outlet, OD (in.)	5/8	5/8	7/8	7/8	7/8	7/8
Condensate, ID (in.)	3/8	3/8	3/8	3/8	3/8	3/8
Filtration						
Type	Cleanable Wire Framed					
Quantity	1	1	2	2	3	3
Arrestance	80%	80%	80%	80%	80%	80%
Type	MERV 10 Throwaway					
Quantity	1	1	2	2	3	3
Size (in.)	12 x 12 x 1	12 x 12 x 1	12 x 24 x 1	12 x 24 x 1	12 x 24 x 1	12 x 24 x 1
Condensate Pump						
Maximum Head (in.)	30	30	30	30	30	30
Nominal Flow Rate (gpm)	0.1	0.1	0.1	0.1	0.1	0.1
Heating Option						
Electric Heating Capacity (kW)	1.5	1.5	3.0	3.0	5.0	5.0
Hot Water Heating Capacity (Btuh)	17,100	N/A	27,300	27,900	41,200	45,200
Hot Water Coil Connection, OD (in.) (Sweat)	5/8	N/A	5/8	5/8	5/8	5/8
Branch Duct Option						
Branch Duct Connections (quantity)	2	2	2	2	2	2
Branch Duct Diameter (in.)	5	5	5	5	6	6
Ducted Air Volume (cfm)	80	80	100	125	200	220
Fresh Air Option						
Fresh Air Connections (quantity)	1-2	1-2	1-3	1-3	1-3	1-3
Fresh Air Duct Diameter (in.)	3	3	3	3	3	3
Fresh Air Volume (cfm)	40	40	60	65	90	95

LEGEND

- ID** — Inside Diameter
- N/A** — Not Applicable
- OD** — Outside Diameter

NOTES:

1. Nominal cooling capacity based on 80°F/67°F DB/WB, water temperature of 45°F inlet/55°F outlet, 208V/1Ph/60Hz supply voltage, and standard filters.
2. Nominal heating capacity based on 70/60°F DB/WB, water temperature of 180°F inlet/160°F outlet, 208V/1Ph/60Hz supply voltage, and standard filters.
3. Ducted air volume based on maximum air volume available through one branch duct 6 ft long, with cassette fan(s) at high speed and corresponding fascia aperture closed.
4. Fresh air volume based on maximum fresh air through all knock-outs connected to one 10 ft long duct with fan at high speed.

Options and accessories



ITEM	FACTORY-INSTALLED OPTIONS	FIELD-INSTALLED ACCESSORIES
Electro-Mechanical Controls	X	
Microprocessor Controls	X	
Electric Heat	X	
Hot Water Coil	X	
Hot Water Coil Freeze Protection Sensor	X	
Disconnect Switch	X	
Chilled Water/Hot Water Control Valve		X
Fresh Air Intake Duct Collar		X
Branch Duct Collars		X
Spare Filters		X
Shroud		X
Thermostats		X
Aquastat		X

Factory-installed options

Electro-mechanical controls

Electro-mechanical controls include an electro-mechanical controller with a 24-v transformer. The controller requires a 24-v thermostat which can be supplied loose for onsite wall mounting. Thermostat options include cooling only or cooling and one stage auxiliary heat. Only single fan speed thermostats can be used with this option. Units are wired for medium speed. Wiring may be field modified if high or low fan speed is desired.

Microprocessor controls

Microprocessor controls include a custom designed microprocessor fitted to the cassette to enable room conditions to be maintained at a user-defined set point. Communication to the controller is by a handheld infrared transmitter or a wall-mounted thermostat.

The microprocessor allows five operating modes: fan only, dry cooling, cooling only, heating only, and heating/cooling with auto changeover for maximum versatility. A temperature set point between 58°F and 90°F can also be selected.

The microprocessor monitors indoor coil temperature and return-air temperature. The receiver contains a self diagnostic feature. When a low indoor coil temperature is detected, the cooling action is stopped. If a sensor fails then an alarm is displayed on the fascia-mounted receiver.

The microprocessor is controlled with either an infrared transmitter or wall-mounted thermostat, depending on the transmitter type selected at the time of order.

The infrared transmitter or wall-mounted thermostat is used to switch the unit on/off, change temperature settings, fan speed, operating mode, and to toggle the motorized air sweep (where fitted).

The microprocessor also has an built-in clock which can be activated to enable the unit to be programmed with up to two separate operating periods for the days of the week (Mon-Fri).

The clock provides ON/OFF unit operation and is not a night set back or occupied/unoccupied control function. Mon-Fri will operate as a 'block' of days and cannot be programmed independently of one another. Saturdays and Sundays can each be programmed with up to two separate operating periods and are programmed independently of the weekdays and each other.

A fascia-mounted receiver displays on/off, cool or heat, and timer/alarm status.

Electric heat (single stage)

Single stage electric heat includes fitted heating elements manufactured for maximum surface area and lower working temperature for improved reliability. Thermal cutout protection switches are fitted to the electric heat circuit to protect against overheating. The optional electric heating elements are available with the 208/220/230-v model units only.

Hot water heat

Hot water heat includes hot water heating coil factory fitted to the standard chilled water coil to provide heating. The coil is manufactured from copper tubes with mechanically bonded aluminum fins. The hot water heat option is not available on unit size 12.

Hot water coil freeze protection sensor

The sensor is mounted to prevent freezing of the hot water coil assembly. When the sensor detects a freeze up condition, it will force the flow control valve open and prevent the unit fan(s) from running.

Disconnect switch (non-fused)

The non-fused disconnect switch is factory installed on the control panel exterior and sized for the full load amperage of the unit to enable the unit to be disconnected from the power supply prior to any maintenance.

Field-installed accessories

Chilled water/hot water control valve

The chilled water/hot water control valve includes a three-way, three-port diverting type valve or a two-way, two-port control valve for control of chilled water or hot water flow. Valve is supplied loose. Actuation is via a 24-v signal from the unit's electrical panel.

On a four-pipe system where two-way valves are specified, the chilled water valve will be a normally closed type. The hot water valve will be a normally open type. Where three-way valves are specified, the same type valve will be supplied for both coils and should be installed normally closed to the coil in the case of the chilled water coil and normally open to the coil in the case of the hot water coil.

On a two-pipe changeover system where a two-way valve is specified, a normally open valve is supplied. Where a three-way valve is specified, this should be installed normally open to the coil. In both cases, a pipe mounted changeover thermostat can also be supplied to monitor water supply temperature and allow action of the valve.

Options and accessories (cont)



Fresh air intake

Fresh air intake can be achieved by removing any number of the two or three (size dependent) fresh air knockouts on the cassette chassis. Each individual knock-out accommodates 20 cfm of fresh air. A duct collar is available for fastening to the unit to allow connection of a 3 in. flexible duct.

Duct collars

Duct collars are available to allow connection of a 5 in. or 6 in. (depending on unit size) flexible duct to the cassette. Branch ducting can be achieved by removing the branch duct knockouts and connecting flexible ducting for circulating a limited amount of conditioned air. For unit sizes 08,12, a total of three knockouts are positioned on three of the unit sides (one per side). For unit sizes 18-36, a total of four knockouts are available and are arranged in pairs along two of the unit sides (two per side).

NOTE: On the 08,12 size units, it is recommended that only one of the three branch duct knockouts is utilized, due to the small capacity of the unit.

Spare filters

These accessories include either a cleanable wire mesh filter or a throwaway MERV 10 filter.

Shroud

The shroud is a sheet metal cover used to cover unit housing when the unit is not mounted in a drop or false ceiling. The shroud is painted Sky White with a hammertone finish.

Thermostats

Thermostats are available for use with both the electromechanical controller and microprocessor options. These thermostats operate with 24-v power and are for wall mounting. Several options are available depending upon system type.

Aquastat

An aquastat is available for use with a 2-pipe heating/cooling changeover system.

42WKN08 AND 42WKN12 UNIT

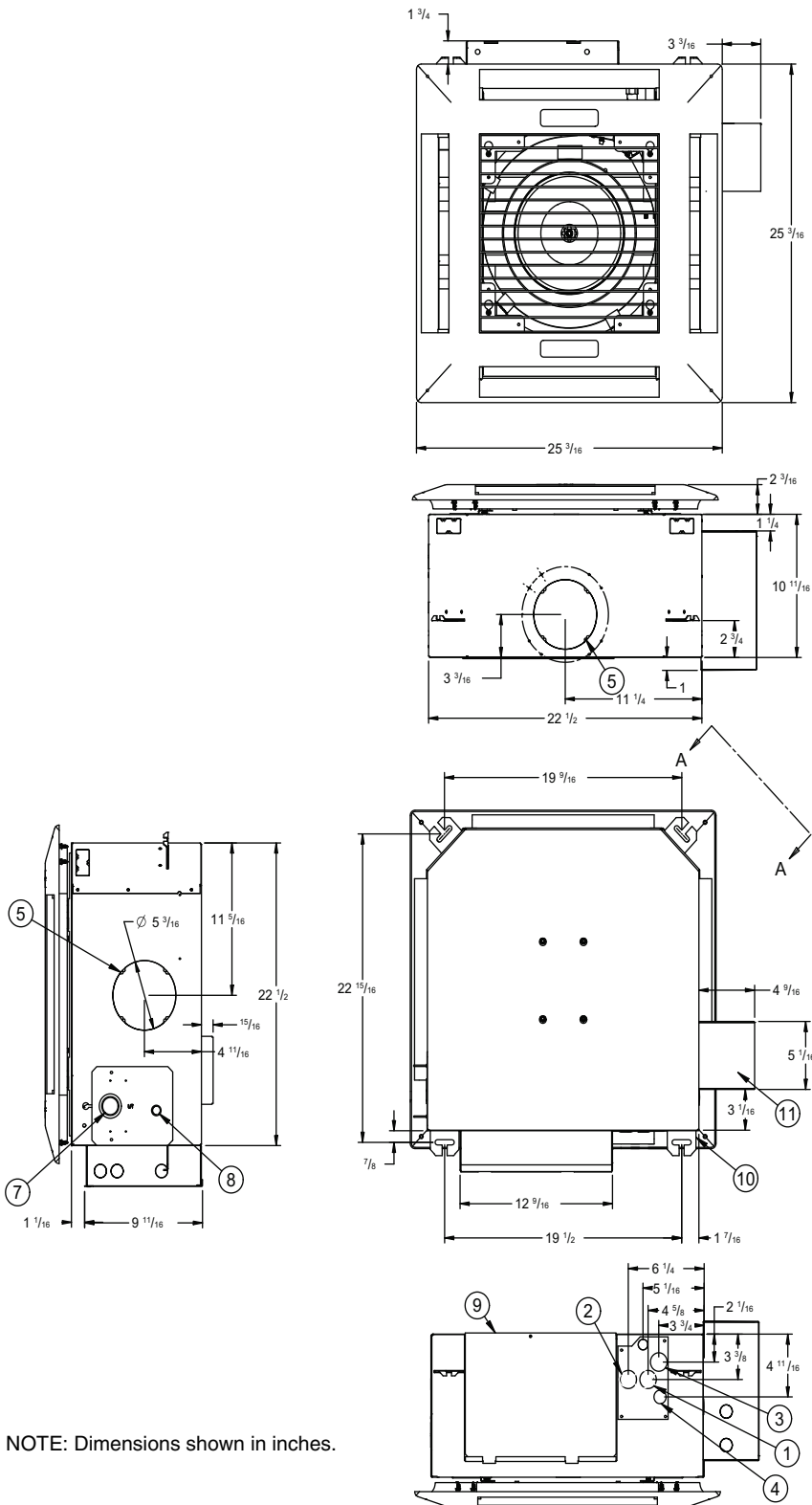

- 1 CW OUTLET
- 2 CW INLET
- 3 HW INLET (Optional)
- 4 HW OUTLET (Optional)
- 5 BRANCH DUCT OPENING (x3)
- 6 FRESH AIR INTAKE (x2)
- 7 PUMP INSPECTION PORT
- 8 CONDENSATE DRAIN
- 9 CONTROL PANEL
- 10 MOUNTING BRACKET
- 11 ELECTRIC HEAT FUSE BOX OR TRANSFORMER

VIEW A-A

NOTE: Dimensions shown in inches.

42WKN18 AND 42WKN20 UNIT

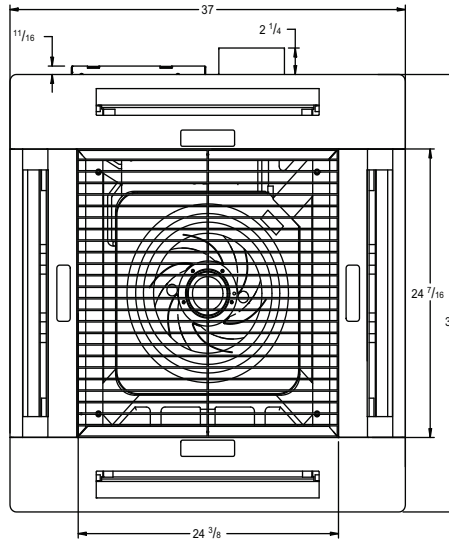

- 1 CW OUTLET
- 2 CW INLET
- 3 HW INLET (Optional)
- 4 HW OUTLET (Optional)
- 5 FRESH AIR INTAKE (x3)
- 6 BRANCH DUCT OPENING (x4)
- 7 PUMP INSPECTION PORT
- 8 CONDENSATE DRAIN
- 9 CONTROL PANEL
- 10 MOUNTING BRACKET
- 11 ELECTRIC HEAT FUSE BOX OR TRANSFORMER

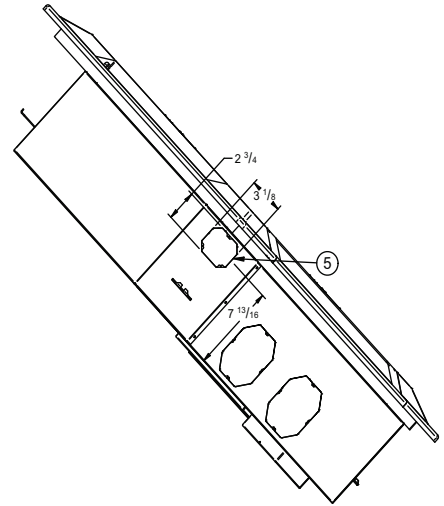
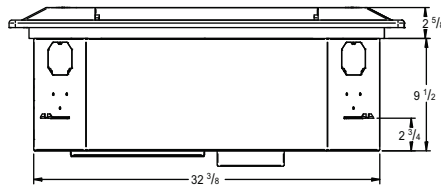

VIEW A-A

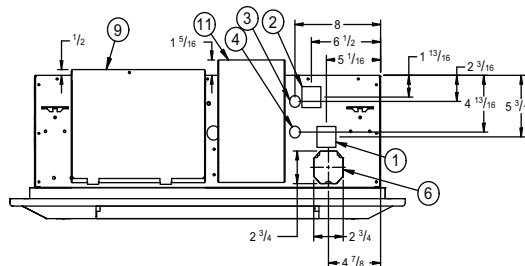
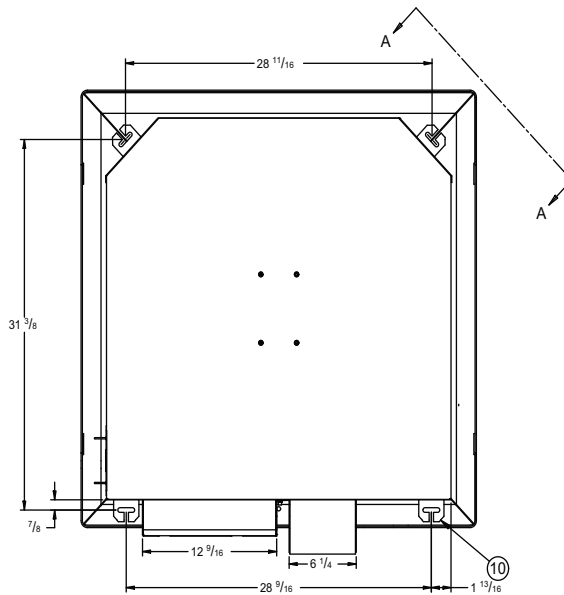
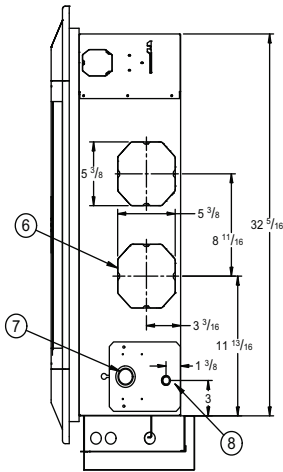

NOTE: Dimensions shown in inches.

42WKN33 AND 42WKN36 UNIT

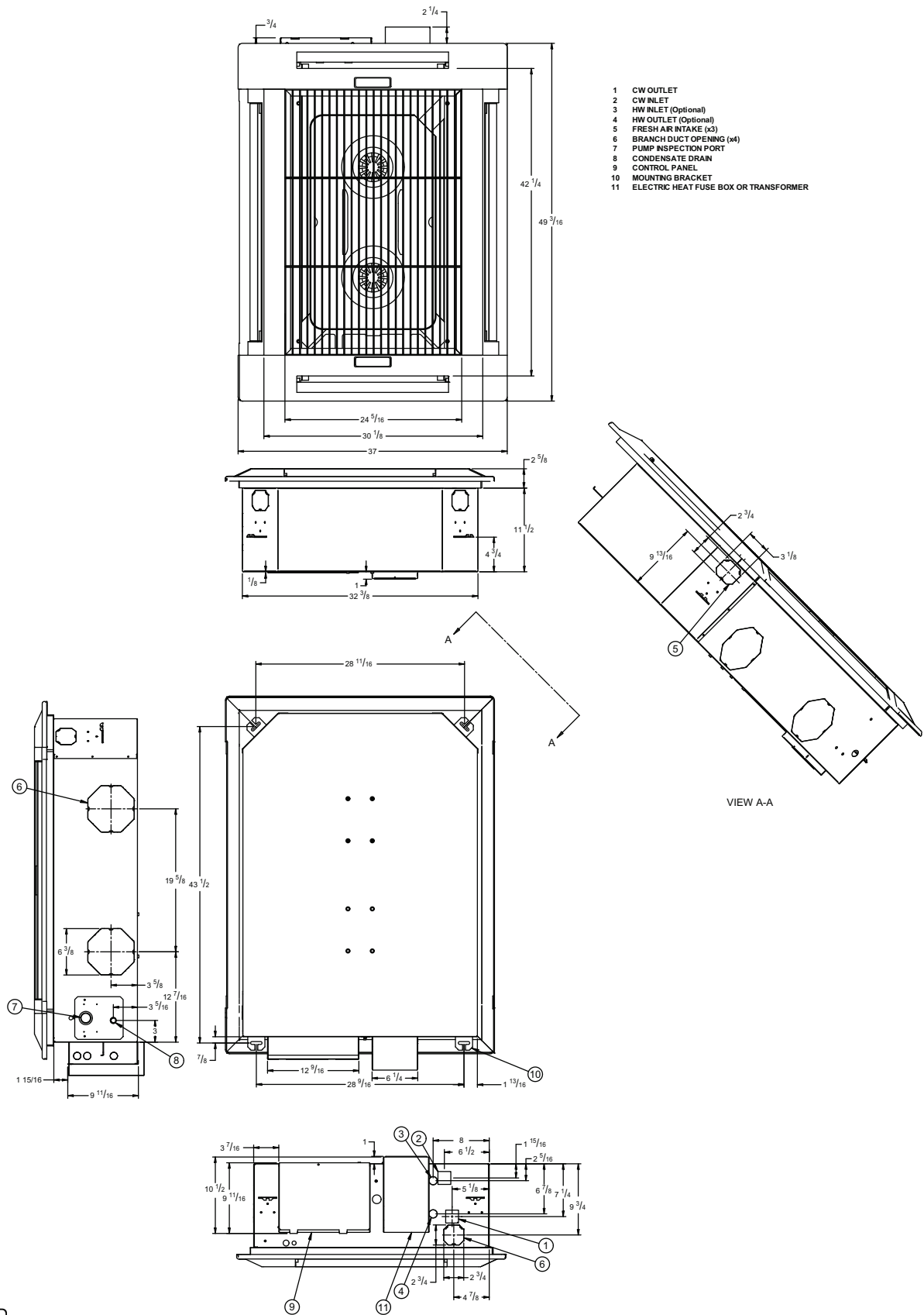

NOTE: DIMENSIONS SHOWN IN INCHES.

Selection procedure (42WKN unit example)



I Determine job requirements.

Given:

Room Sensible Cooling Load	8,200 Btuh
Room Total Cooling Load	11,000 Btuh
Entering-Air Temperature	80 F at 50% RH
Entering Water Temperature	45 F
Temperature Rise	10 F
Nominal Air Delivery	350 cfm

II Determine unit size and nominal cfm.

For an initial selection, choose a unit size that will provide the required airflow (cfm). Refer to the Physical Data table on page 4. At high speed, a 42WKN12 unit will provide 350 cfm.

III Determine total cooling capacity.

Refer to the cooling capacity table for 42WKN12 on page 11. Locate required entering dry bulb (edb) and relative humidity (RH) conditions. Locate the entering water temperature required. Under Total Cooling (TC) column, a 42WKN12 unit at an entering-air temperature of 80°F dry bulb at 50% RH, an entering water temperature of 45°F, and a water temperature rise of 10°F, will provide 11,200 Btuh.

IV Determine sensible cooling capacity.

In cooling capacity table for 42WKN12, locate the sensible cooling (SC) column and find that the 42WKN12 at the required conditions will provide 8,200 Btuh of sensible cooling at a water temperature rise of 10°F. The 42WKN12 will satisfy the job requirements.

If additional SC were required, a larger unit or a lower entering water temperature would be needed.

CHILLED WATER UNIT COOLING CAPACITIES

42WKN UNIT SIZE	FILTER	ENTERING DB AIR TEMPERA- TURE (F) at 50% RH	CHILLED WATER ENTERING/LEAVING TEMPERATURE							
			40/50°F				45/55°F			
			TC (Btuh)	SC (Btuh)	Flow (gpm)	Pressure Drop (psi)	TC (Btuh)	SC (Btuh)	Flow (gpm)	Pressure Drop (psi)
08	STD	72	5,900	4,900	1.2	2.9	4,100	3,900	0.8	1.5
		75	7,300	5,500	1.5	4.3	5,100	4,500	1.0	2.2
		80	9,900	6,500	2.0	7.4	7,800	5,500	1.6	4.8
	MERV 10	72	4,000	3,300	0.8	1.6	2,800	2,600	0.6	0.8
		75	5,000	3,700	1.0	2.3	3,500	3,100	0.7	1.2
		80	6,800	4,400	1.3	3.8	5,400	3,700	1.1	2.5
12	STD	72	8,800	7,100	1.7	1.7	6,100	5,700	1.2	0.9
		75	10,900	8,000	2.2	2.5	7,600	6,600	1.5	1.3
		80	14,600	9,400	2.9	4.2	11,200	8,000	2.2	2.6
	MERV 10	72	5,300	4,300	1.1	0.7	3,700	3,400	0.7	0.3
		75	6,600	4,800	1.3	1.1	4,600	3,900	0.9	0.5
		80	8,900	5,700	1.8	1.8	6,800	4,800	1.4	1.1
18	STD	72	14,200	11,700	2.8	1.5	10,000	9,500	2.0	0.8
		75	17,700	13,200	3.5	2.2	12,500	10,800	2.5	1.2
		80	23,900	15,600	4.8	3.7	18,200	13,200	3.6	2.3
	MERV 10	72	12,900	10,500	2.6	1.3	9,000	8,500	1.8	0.7
		75	16,000	11,900	3.2	1.8	11,300	9,800	2.3	1.0
		80	21,600	14,000	4.3	3.1	16,500	11,900	3.3	1.9
20	STD	72	14,500	12,000	2.9	1.6	10,200	9,700	2.0	0.8
		75	18,100	13,500	3.6	2.3	12,800	11,100	2.5	1.2
		80	24,500	15,900	4.9	3.9	18,600	13,500	3.7	2.4
	MERV 10	72	12,900	10,500	2.6	1.3	9,000	8,500	1.8	0.7
		75	16,000	11,900	3.2	1.8	11,300	9,800	2.3	1.0
		80	21,600	14,000	4.3	3.1	16,500	11,900	3.3	1.9
33	STD	72	24,400	19,400	4.9	3.1	17,200	15,800	3.4	1.6
		75	30,000	21,800	6.0	4.4	21,400	18,000	4.3	2.4
		80	40,300	25,800	8.0	7.4	31,100	21,900	6.2	4.6
	MERV 10	72	23,300	18,500	4.6	2.8	16,400	15,100	3.3	1.5
		75	28,700	20,800	5.7	4.1	20,500	17,100	4.1	2.2
		80	38,400	24,600	7.7	6.8	29,700	20,800	5.9	4.2
36	STD	72	26,800	21,500	5.3	3.6	18,900	17,500	3.8	1.9
		75	33,100	24,100	6.6	5.2	23,500	19,900	4.7	2.8
		80	44,600	28,600	8.9	8.8	34,300	24,200	6.9	5.5
	MERV 10	72	23,300	18,500	4.6	2.8	16,400	15,100	3.3	1.5
		75	28,700	20,800	5.7	4.1	20,500	17,100	4.1	2.2
		80	38,400	24,600	7.7	6.8	29,700	20,800	5.9	4.2

LEGEND

DB — Dry Bulb
RH — Relative Humidity
SC — Sensible Cooling Capacity
TC — Total Cooling Capacity

NOTES:

1. All duties based on 208V/1Ph/60Hz supply voltage and high fan speed except where stated otherwise.
2. Cooling capacities are gross. Do not include fan motor gains.
3. Pressure drops are coil only (excludes valves).
4. Hot water duties on chilled water units fitted with additional, optional hot water coil. See data on next page.

HEATING PERFORMANCE - CHILLED WATER UNITS WITH OPTIONAL HEATING COIL

42WKN UNIT SIZE	FILTER	HOT WATER 180°F INLET/160°F OUTLET								
		70°F Entering Air DB			60°F Entering Air DB			50°F Entering Air DB		
		Capacity (Btuh)	PD (psi)	Flow (gpm)	Capacity (Btuh)	PD (psi)	Flow (gpm)	Capacity (Btuh)	PD (psi)	Flow (gpm)
08	STD	17,100	2.8	1.7	18,900	3.3	1.9	20,600	3.8	2.0
	MERV 10	13,400	1.8	1.3	14,700	2.1	1.5	16,100	2.5	1.6
18	STD	27,300	1.1	2.7	30,000	1.3	3.0	32,800	1.5	3.3
	MERV 10	24,800	0.9	2.5	27,300	1.1	2.7	29,800	1.3	3.0
20	STD	27,900	1.1	2.8	30,700	1.4	3.1	33,500	1.6	3.3
	MERV 10	24,800	0.9	2.5	27,300	1.1	2.7	29,800	1.3	3.0
33	STD	41,200	1.4	4.1	45,300	1.7	4.5	49,400	2.0	4.9
	MERV 10	42,300	1.5	4.2	45,900	1.7	4.6	48,300	2.0	4.9
36	STD	45,200	1.7	4.5	49,800	2.0	5.0	54,300	2.3	5.4
	MERV 10	42,300	1.5	4.2	45,900	1.7	4.6	49,300	2.0	4.9

NOTES:

- All duties based on 208V/1Ph/60Hz supply voltage and high fan speed except where stated otherwise.
- Pressure drops are coil only, excluding valves.
- Hot water duties based on units fitted with additional, optional hot water coil.
- Hot water coil not available on size 42WKN12.

HEATING PERFORMANCE - CHILLED WATER UNITS WITH 2-PIPE CHANGEOVER

42WKN UNIT SIZE	FILTER	HOT WATER 180°F INLET/160°F OUTLET								
		70°F Entering Air DB			60°F Entering Air DB			50°F Entering Air DB		
		Capacity (Btuh)	PD (psi)	Flow (gpm)	Capacity (Btuh)	PD (psi)	Flow (gpm)	Capacity (Btuh)	PD (psi)	Flow (gpm)
08	STD	21,000	6.3	2.1	23,100	7.5	2.3	25,100	8.8	2.5
	MERV 10	14,200	3.1	1.4	15,600	3.7	1.6	17,000	4.3	1.7
12	STD	29,000	3.1	2.9	31,900	3.7	3.2	34,800	4.4	3.5
	MERV 10	17,400	1.2	1.7	19,100	1.5	1.9	20,800	1.7	2.1
18	STD	55,100	3.6	5.5	60,400	4.2	6.0	65,600	4.9	6.5
	MERV 10	49,200	2.9	4.9	53,900	3.4	5.4	58,600	4.0	5.8
20	STD	55,100	3.6	5.5	60,400	4.2	6.0	65,600	4.9	6.5
	MERV 10	49,200	2.9	4.9	53,900	3.4	5.4	58,600	4.0	5.8
33	STD	80,500	5.5	8.0	88,200	6.4	8.8	95,900	7.5	9.5
	MERV 10	76,500	5.0	7.6	83,900	5.9	8.4	91,200	6.8	9.1
36	STD	89,300	6.6	8.9	97,900	7.8	9.7	106,400	9.1	10.6
	MERV 10	76,500	5.0	7.6	83,900	5.9	8.4	91,200	6.8	9.1

LEGEND

- DB** — Dry Bulb
N/A — Not Applicable
RH — Relative Humidity

NOTES:

- All duties based on 208V/1Ph/60Hz supply voltage and high fan speed except where stated otherwise.
- Pressure drops are coil only, excluding valves.

SOUND DATA

42WKN UNIT SIZE	FAN SPEED	SPL dBA	SOUND PRESSURE FREQUENCY SPECTRUM, dB						
			125 Hz	250 Hz	500 Hz	1000 Hz	2000 Hz	4000 Hz	8000 Hz
08	High	29	37	37	33	29	21	14	10
	Med	26	34	34	30	24	15	12	10
	Low	22	31	29	25	17	8	10	8
12	High	35	42	41	38	35	28	21	12
	Med	32	38	39	36	32	24	16	10
	Low	29	37	37	33	29	21	14	10
18	High	43	41	45	38	40	33	25	17
	Med	39	39	41	35	36	27	19	16
	Low	38	38	40	34	34	25	18	16
20	High	46	43	47	40	43	37	29	19
	Med	43	41	45	38	40	33	25	17
	Low	39	39	41	35	36	27	19	16
33	High	48	51	49	46	42	34	22	19
	Med	44	50	46	43	38	28	18	17
	Low	42	49	44	41	36	25	17	16
36	High	52	54	54	50	46	41	27	24
	Med	48	51	49	46	42	34	22	19
	Low	45	50	47	44	39	31	19	18

LEGEND

SPL — Sound Pressure Level

NOTE: Overall SPL measured at a distance of 5 ft below the fascia in free field, dry coil conditions, referenced to 2×10^5 Pa.

Electrical data



42WKN SIZE AND NOMINAL CAPACITY (Digit 6,7)	SUPPLY VOLTAGE (Digit 8)	PERFORMANCE (WITH ELECTRIC HEAT)*			PERFORMANCE (NO ELECTRIC HEAT)		
		FLA	MCA	Recommended Fuse Size	FLA	MCA	Recommended Fuse Size
08 and 12 Small Chassis	A: 115-60-1	—	—	—	0.70	0.88	15
	J: 110-50-1						
	B: 208-60-1	6.25	7.81	15	0.35	0.44	15
	C: 230-60-1	6.87	8.59	15			
	K: 220-50-1	6.59	8.24	15			
	H: 277-60-1	—	—	—	0.29	0.36	15
18 and 20 Medium Chassis	A: 115-60-1	—	—	—	1.10	1.38	15
	J: 110-50-1						
	B: 208-60-1	12.35	15.44	20	0.55	0.69	15
	C: 230-60-1	13.59	16.99	20			
	K: 220-50-1	13.03	16.29	20			
	H: 277-60-1	—	—	—	0.46	0.58	15
33 and 36 Large Chassis	A: 115-60-1	—	—	—	1.92	2.40	15
	J: 110-50-1						
	B: 208-60-1	20.68	25.85	30	0.96	1.20	15
	C: 230-60-1	22.76	28.45	30			
	K: 220-50-1	21.81	27.26	30			
	H: 277-60-1	—	—	—	0.80	1.00	15

LEGEND

FLA — Full Load Amps
MCA — Minimum Circuit Amps

*Standard unit fitted with optional electric heating elements. Available with 208/220/230-v model units only.

Typical wiring schematic

NOTE: Refer to Installation and Operation manual for wiring schematic.

Sequence of operation

Electro-mechanical controls

A 24-v signal from the thermostat to terminal G supplies power to the blower motor(s), condensate pump and vane motor (if equipped). A toggle switch on the control box can be used to switch the oscillating vanes on or off. The condensate pump will run continuously, as long as the blower is energized. A call for heating, at terminal W, or cooling, at terminal Y, will energize the water valve actuator and allow water to flow through the cassette coil. When the call for heating or cooling is satisfied the valve will close.

If the temperature drops below the set point of the coil freeze stat, the water valve will automatically open to circulate water through the coil.

If the condensate float switch detects a high level of water in the condensate tray, the switch will open, activate the condensate pump and disable the heating/cooling signal until the water level drops down to normal.

Microprocessor controls

The PCB (printed circuit board) microprocessor control board relays control the operation of the indoor-fan motor, outdoor-fan motor, compressor and electric heater (if fitted), to maintain room conditions at a user-defined set point.

Temperature settings, fan speeds and other control functions can be changed by the infrared transmitter or wall-mounted thermostat. The controller PCB provides the following input/output facilities:

Inputs

T1 Return Air Temperature Sensor: 50k at 77°F.

T3 Indoor Coil Temperature Sensor: 50k at 77°F.

Outputs

Indoor fan motor: The controller will switch a combination of three, 10-amp, 230-vac (3 speed settings) resistive rated relays to deliver the selected indoor fan speed.

Condensate pump

Activated when unit is in cooling mode.

Vane motor

A 10-amp, 230-vac resistive rated relay switches the vane motor on when Air Sweep is selected (units sizes 18-36 only).

Electric heat

A 30-amp, 230-vac resistive rated relay switches the electric heater on when required.

Indoor fan operation

The indoor fan will run continuously at the most recently set speed or will alter the speed according to the room temperature conditions when set to Auto. The indoor fan will continue to run until the unit is turned off by the user or by a preset time setting. When the unit is turned off during heating, the indoor fan will continue to run for approximately 2 minutes, this helps to dissipate residual heat from the electric heaters.

Boost heat

The electric heat relay can be used to initiate either low watts density electric heating (optional) or low pressure hot water heating (optional). The boost heat will be activated when the room temperature falls to more than 8°F below set point. Hysteresis of 2°F will be applied to prevent "hunting." The boost heat facility is automatically enabled or disabled by selecting non heat pump (Jumper 2 open).

Temperature control

The controller will switch heating or cooling loads in order to maintain the temperature set point. The deadband is programmed to 4°F. Under normal operation, cooling or heating will be activated at the limits of the deadband and will continue to operate until set point is achieved.

The temperature set point can be adjusted between 58 and 90°F in 2°F increments.

Power failure

The controller will auto restart in its previous mode of operation after a power failure. When power is restored, the controller will revert to its last operating mode, e.g., if the controller was turned on before power fail, after power is restored the controller will automatically turn on. Alternatively, if the controller was turned off before power fail, the controller will remain off after power is restored.

Electric heater overheat protection

In the event of an auto reset overheat cutout, the electric heater will be switched off until the temperature drops sufficiently for the auto cutout to reset itself.

Commercial Hydronic Cassette Fan Coil

HVAC Guide Specifications

Size Range: $\frac{3}{4}$ to 3 Tons

7,800 to 34,300 Btuh,

Nominal Cooling

17,100 to 45,200 Btuh,

Nominal Heating

Carrier Model Number: **42WKN**

Part 1 — General

1.01 SYSTEM DESCRIPTION

Indoor, in-the-ceiling mounted, chilled or hot water coil, to be matched with a commercial chiller, water source heat pumps, or hot water boiler (180 F maximum).

1.02 QUALITY ASSURANCE

Base unit shall be certified by UL (Underwriters Laboratories). Each coil shall be factory tested for leakage at 325 psig air pressure with coil submerged in water. Insulation and adhesive shall meet NFPA-90A (National Fire Protection Association) requirements for flame spread and smoke generation. Insulation shall be rated to UL94 VO. All equipment wiring shall comply with NEC (National Electrical Code) requirements.

1.03 DELIVERY, STORAGE, AND HANDLING

Unit shall be stored and handled per manufacturer's instructions.

1.04 WARRANTY (One year on parts).

Part 2 — Products

2.01 EQUIPMENT

A. General:

Indoor, downward discharge 2 or 4-pipe low-profile in-ceiling fan coil. Units shall come complete with cooling coil or hot water coil (4-pipe systems only), fan, fan motor, piping connectors, electrical controls, condensate pump, and hanging brackets.

B. Unit Cabinet:

1. Cabinet shall be constructed of galvanized sheet steel. Cabinet shall have filter tracks and cleanable filters which shall be accessible from below. Adjacent room cooling to be provided by a simple knockout in the cabinet side panel, and cabinet shall have provisions to accommodate a limited amount of ductwork, if desired.
2. Fan shall be a centrifugal, direct-drive blower type with air intake in center of the unit and discharge on the perimeter. Air louvers shall be adjustable for 2, 3 or 4-way discharge. Air outlet vanes shall be fully insulated aluminum to prevent condensation from forming. Vanes shall be manually adjustable on unit sizes 08,12, but shall be driven by an electric motor for unit sizes 18-36.
3. Fascia shall be constructed of high impact polystyrene.

C. Coil:

1. Standard base unit shall be equipped with a cooling coil for installation in a 2-pipe system. Additional coil depth and circuiting shall be provided for installation in a 4-pipe system.
2. Heating coils are single row, independently circuited coils specifically designed for hot water application. Heating coil is located downstream from cooling coil.
3. Coils shall have $\frac{1}{2}$ -in. copper tubes, aluminum fins bonded to the tubes by mechanical expansion, and a working pressure of 325 psig.
4. Each coil shall have a manual air vent on upper connection, a drain port on the lower connection.

D. Motors:

Motor shall be enclosed and with thermal overload protection, sealed for life lubricated bearings, and external rotor allowing good heat dissipation. Fan motor shall be 3-speed.

E. Controls:

Controls shall be 24-v, and shall be easily operated by the user from a wall-mounted thermostat. A normally closed float control shall be in the condensate sump to shut unit down in case of pump malfunction.

F. Alarm Interlock Relay:

Alarm interlock relay shall include a relay for unit failure notification. Normally open/normally closed contacts are available for field connection.

G. Filters:

Unit shall have a filter track with factory-supplied cleanable filters or MERV 10 disposable filters.

H. Electrical Requirements:

Unit shall operate on a 115-v, 208-v, 230-v or 277-v 60 Hz power supply or on 110-v or 220-v 50 Hz power supply as specified on the equipment schedule.

I. Operating Characteristics:

A one-coil unit installed in a 2-pipe system shall be capable of providing cooling as specified by the operating mode of the central water supply system. A double-circuit coil unit installed in a 4-pipe system shall be capable of providing sequenced heating and cooling.

J. Special Features:

1. Fresh Air Intake Kit:

The fresh air intake kit shall include duct collars for connection to the unit.

2. Duct Collars:

Duct collars shall be available to allow connection of a 5 in. or 6 in. (depending on unit size) flexible duct to the cassette.

3. Thermostat:

The thermostat shall be commercial grade to control unit operation and shall provide single speed fan capability. Automatic changeover from cooling or heating shall be provided (4-pipe systems only).

4. Motorized Valve Accessory:

The motorized valve shall be a two-position, spring return two or three-way valve.

5. Microprocessor Control:

a. The microprocessor control shall include a custom designed microprocessor fitted to the cassette to enable room conditions to be maintained at a user defined set point.

b. Microprocessor controller shall allow automatic control of fan speed based on demand in space. The controller, either an infrared transmitter or wall-mounted thermostat, also allows programming of a weekly operating schedule.

6. Electric Heat:

Single-stage electric heat shall include fitted heating elements manufactured for maximum surface area and lower working temperature for improved reliability. Thermal cutout protection switches are fitted to the electric heat circuit to protect against overheating. The

optional electric heating elements are available with the 208/220/230-v model units only.

7. Hot Water Coil Freeze Protection Sensor:

The freeze protection sensor shall be available for mounting to prevent freezing of the hot water coil assembly. When the sensor detects a freeze up condition, it will force the flow control valve open and prevent the unit fan(s) from running.

8. Disconnect Switch:

The non-fused disconnect switch shall be factory mounted on the exterior of the control panel and sized for the full load amperage of the unit to enable the unit to be disconnected from the power supply prior to any maintenance.

9. Shroud:

A shroud shall be available as a sheet metal cover used to cover unit housing when the unit is not mounted in a drop or false ceiling. The shroud is painted Sky White with a hammer-tone finish.

10. Aquastat:

An aquastat shall be available for use with a 2-pipe heating/cooling changeover system.

