



Installation, Operation and Maintenance Instructions

TABLE OF CONTENTS

SAFETY CONSIDERATIONS	1	On/Off	54
INSPECTION	2	Fan Speeds	54
GENERAL	2	Modes	54
CONTROLS DESCRIPTION	7	Temperature Set Point	54
Microprocessor Control Board	7	Clock	54
Inputs	7	Timer	54
Outputs	7	Battery Replacement	54
External Connections	7	CONTROLS	55
Microprocessor PCB Battery	7	Setting Jumper Links	55
Controller	7	Main Control Functions	55
Infrared Receiver	7	• INDOOR FAN OPERATION	
Self Diagnostics	7	• TEMPERATURE CONTROL	
Receiver Indicators	7	• POWER FAILURE	
PRE-INSTALLATION	39	Alarms	55
Unpack Unit	39	MAINTENANCE	55
Blank Off Pieces	39	Maintenance Schedule	55
Positioning	39	• EVERY 3 MONTHS	
Ceiling Opening Sizes	39	• EVERY 6 MONTHS	
Positioning the Electro-Mechanical		• EVERY 12 MONTHS	
Thermostat	39	Filter Removal and Cleaning	55
INSTALLATION	39	Recommended Spares	55
Hanger Bolts	39	DISASSEMBLY PROCEDURE	56
Installation Guide	39	Fan Removal	56
• INSTALLATION GUIDE SETUP		Condensate Tray Removal	56
Condensate Piping	40	Condensate Pump Removal	56
Duct Collars	40	TROUBLESHOOTING	56
Piping Installation	40	REPLACEMENT PARTS	59
Piping Insulation	41		
Wiring	41		
Terminal Strip Connections	42		
Fascia Assembly	52		
PRE-START-UP	52		
Pre-Start Checks	52		
Control Circuit Checks	52		
Sequence of Operation	54		
• ELECTRO-MECHANICAL CONTROLS			
• MICROPROCESSOR CONTROLS			
OPERATION	54		

SAFETY CONSIDERATIONS

Installing and servicing air-conditioning equipment can be hazardous due to system pressure and electrical components. Only trained and qualified service personnel should install and service air-conditioning equipment. See Fig. 1 for Proposition 65 warning label.

Untrained personnel can perform basic maintenance such as cleaning and replacing filters. All other operations should be performed by trained service personnel. When working on air-conditioning equipment, observe safety precautions in literature and on tags and labels attached to the unit.

1. The equipment has been designed and manufactured to meet international safety standards but, like any mechanical/electrical equipment, care must be taken to obtain the best results.

2. Service and maintenance of this equipment should only be carried out by skilled personnel.
3. When working with any air-conditioning unit, ensure that the electrical disconnect supplying the unit is switched off prior to servicing or repair work and that there is no power to any part of the equipment.
4. Also ensure that there are no other power feeds to the unit such as fire alarm circuits, building management system (BMS) circuits, etc.
5. Electrical installation, start-up and maintenance work on this equipment should be undertaken by competent and trained personnel in accordance with local relevant standards and codes of practice.

⚠ DANGER

Appliances must not be installed where they may be exposed to potentially explosive or flammable atmosphere.

⚠ WARNING

Improper installation, adjustment, alteration, service or maintenance can cause property damage, injury or death. Read the installation, operating and maintenance instructions thoroughly before installing or servicing this equipment.

⚠ WARNING

Disconnect power supply before making wiring connections to prevent electrical shock and equipment damage. All appliances must be wired strictly in accordance with the wiring diagram furnished with the appliance. Any wiring different from the wiring diagram could result in a hazard to persons and property.

⚠ CAUTION

Any original factory wiring that requires replacement must be replaced with wiring material having a temperature rating of at least 105°C.

Ensure that the supply voltage to the appliance, as indicated on the serial plate, is not more than 5% over rated voltage or less than 5% under the rated voltage.

When servicing or repairing of this equipment, use only factory-approved service replacement parts. Refer to the rating plate on the appliance for complete appliance model number, serial number and company address. Any substitution of parts or controls not approved by the factory will be at the owner's risk.

Do not attempt to reuse any mechanical or electrical controllers which have been wet. Replace defective controller.

IMPORTANT: Make sure the ceiling grid is supported separately from the appliance. The ceiling must not be supported by any part of the appliance, fascia or any associated wiring or pipe work.

Start-up and adjustment procedures should be performed by a qualified service agency.



Fig. 1 — Proposition 65 Warning Label

INSPECTION

1. Inspect unit upon arrival. In case of damage, report immediately to transportation company and your local factory sales representative.
2. Check rating plate on unit to verify that the power supply meets available electric power at the point of installation.
3. Inspect unit received for conformance with description of product ordered (including specifications where applicable).

GENERAL

The 42WKN ceiling cassette units effectively make each area served an independently controlled temperature zone. Through thermostatic control of operations, conditions can be varied to suit diverse requirements or activities. Optional controls, plus outside and return-air connections, are available to provide for ventilation and recirculation of room air.

The 42WKN hydronic fan coil unit water connections are fixed to the unit body to avoid breaks when the pipes are connected. The upper coil connection is supplied with an air purge valve; the lower connection is supplied with a water purge valve. Minimum entering water temperature for the water circuit is 39°F; maximum is 180°F. If room temperature goes down to 32°F or lower, it is advisable to empty the water circuit to avoid the potential for ice breaks.

Refer to Table 1 for unit physical data and Fig. 2-4 for unit dimensional data.

Table 1 — 42WKN Physical Data

42WKN UNIT SIZE	08	12	18	20	33	36
Nominal TONS	¾	1	1½	1¾	2½	3
COOLING CAPACITY (Btuh)	7,800	11,200	18,200	18,600	31,100	34,300
Dimensions/Weights						
Height – Chassis/Fascia (in.) (not additive)	11¾ / 1¼	11¾ / 1¼	11 / 1¾	11 / 1¾	13 / 1¾	13 / 1¾
Width – Chassis/Fascia (in.)	22½ / 25	22½ / 25	32¾ / 37	32¾ / 37	45½ / 49¼	45½ / 49¼
Depth – Chassis/Fascia (in.)	22½ / 25	22½ / 25	32¾ / 37	32¾ / 37	32¾ / 37	32¾ / 37
Weight – Chassis/Fascia (lb)	40 / 5	40 / 5	64 / 18	64 / 18	97 / 21	97 / 21
Chilled Water Coil						
Type	Finned Tube					
Quantity	1	1	1	1	1	1
Face Area (sq ft)	1.8	1.8	2.8	2.8	5.2	5.2
Nominal Airflow (cfm)						
High	330	360	600	620	940	1080
Medium	300	330	540	600	850	940
Low	260	300	460	540	740	850
Discharge	4-way	4-way	4-way	4-way	4-way	4-way
Unit Water Volume (gal)	0.29	0.29	0.45	0.45	0.79	0.79
FAN						
Type	Centrifugal					
Quantity	1	1	1	1	2	2
Diameter (in.)	12	12	15	15	14	14
Horsepower per fan (Hp)	⅛	⅛	⅙	⅙	⅙	⅙
CONNECTIONS (Sweat)						
Chilled Water Inlet, OD (in.)	⅝	⅝	⅞	⅞	⅞	⅞
Chilled Water Outlet, OD (in.)	⅝	⅝	⅞	⅞	⅞	⅞
Condensate, ID (in.)	⅜	⅜	⅜	⅜	⅜	⅜
Filtration						
Type	Cleanable Wire Framed					
Quantity	1	1	2	2	3	3
Arrestance	80%	80%	80%	80%	80%	80%
Condensate Pump						
Maximum Head (in.)	30	30	30	30	30	30
Nominal Flow Rate (gpm)	0.1	0.1	0.1	0.1	0.1	0.1
HEATING OPTION						
Electric Heating Capacity (kW)	1.5	1.5	3.0	3.0	5.0	5.0
Hot Water Heating Capacity (Btuh)	17,100	N/A	27,300	27,900	41,200	45,200
Hot Water Coil Connection, OD (in.) (Sweat)	⅝	N/A	⅝	⅝	⅝	⅝
Branch Duct Option						
Branch Duct Connections (quantity)	2	2	2	2	2	2
Branch Duct Diameter (in.)	5	5	5	5	6	6
Ducted Air Volume (cfm)	80	80	100	125	200	220
Fresh Air option						
Fresh Air Connections (quantity)	1-2	1-2	1-3	1-3	1-3	1-3
Fresh Air Duct Diameter (in.)	3	3	3	3	3	3
Fresh Air Volume (cfm)	40	40	60	65	90	95

LEGEND

ID — Inside Diameter
OD — Outside Diameter

NOTES:

1. Nominal cooling capacity based on 80°F dry bulb / 67°F wet bulb indoor and a 45°F entering/ 55°F leaving chilled water temperature, 208-v/1Ph/60Hz supply voltage, and standard filters.
2. Nominal heating capacity based on water temperature of 180°F inlet /160°F outlet and an air temperature of 70°F dry bulb/60°F wet bulb, 208-v/1Ph/60Hz supply voltage, and standard filters.
3. Ducted air volume based on maximum air volume available through one branch duct 6 ft long, with cassette fan(s) at high speed and corresponding fascia aperture closed.
4. Fresh air volume based on maximum fresh air through all knock-outs connected to one 10 ft long duct with fan at high speed.

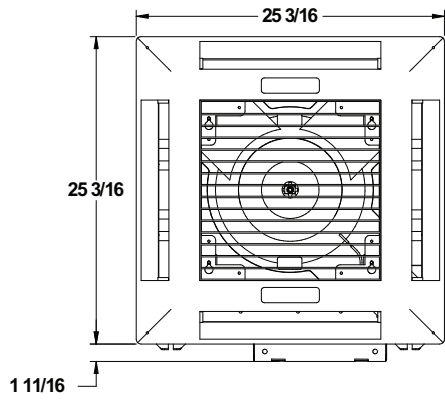

1. CW Inlet
2. CW Outlet
3. HW Coil Inlet (Optional)
4. HW Coil Outlet (Optional)
5. Branch Duct Opening (x3)
6. Fresh Air Intake (x2)
7. Pump Inspection Port
8. Condensate Drain
9. Control Panel
10. Mounting Bracket

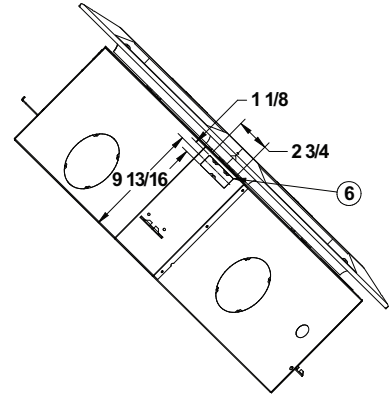
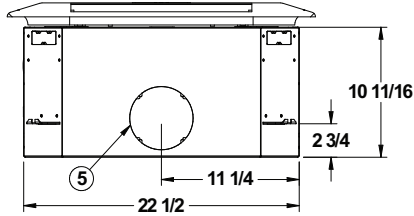

VIEW A-A

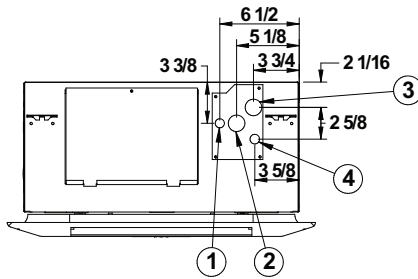
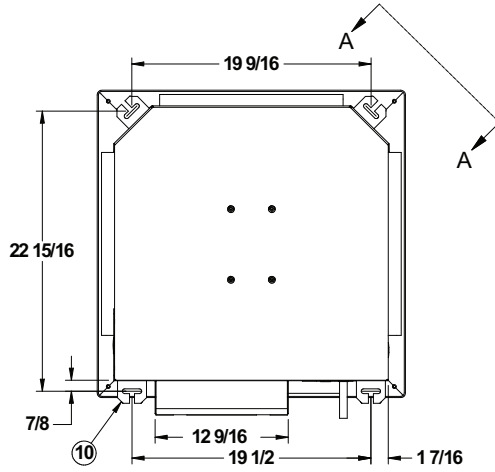
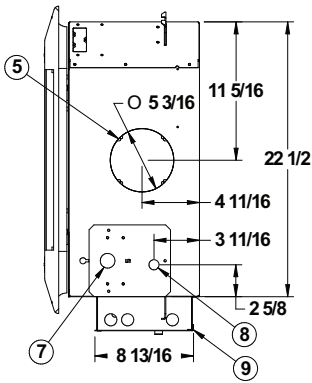

NOTE: Dimensions shown in inches.

Fig. 2 — 42WKN08,12 Dimensions

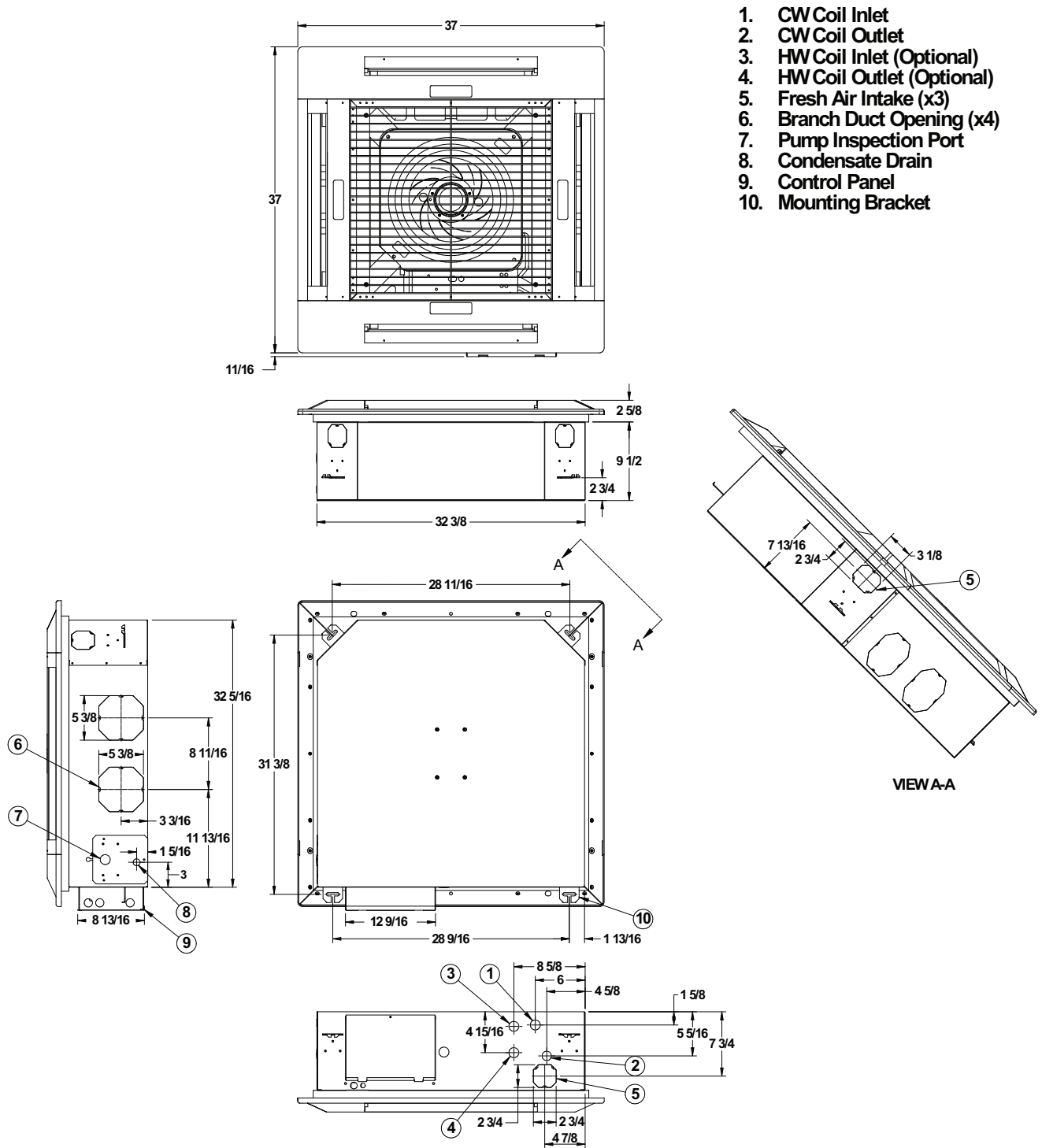

NOTE: Dimensions shown in inches.

Fig. 3 — 42WKN18,20 Dimensions

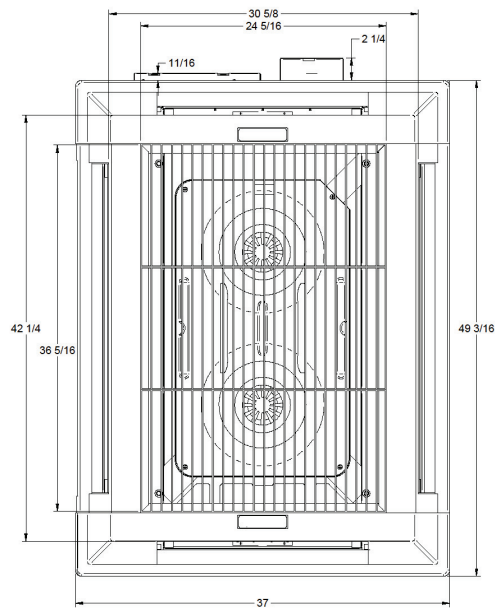

- 1 DX LIQUID LINE
- 2 DX SUCTION LINE
- 3 HW INLET (Optional)
- 4 HW OUTLET (Optional)
- 5 FRESH AIR INTAKE (x3)
- 6 BRANCH DUCT OPENING (x4)
- 7 PUMP INSPECTION PORT
- 8 CONDENSATE DRAIN
- 9 CONTROL PANEL
- 10 MOUNTING BRACKET
- 11 ELECTRIC HEAT FUSE BOX OR TRANSFORMER

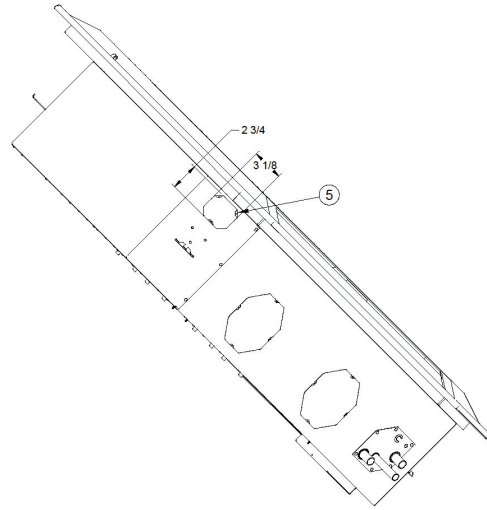
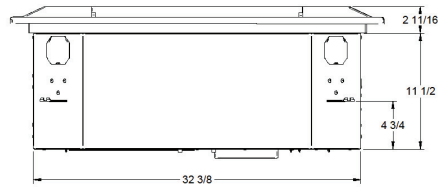

VIEW A-A

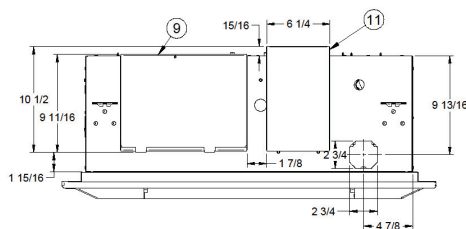
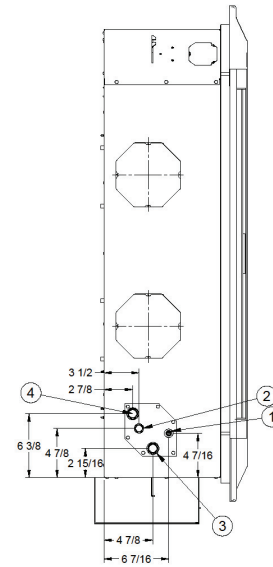
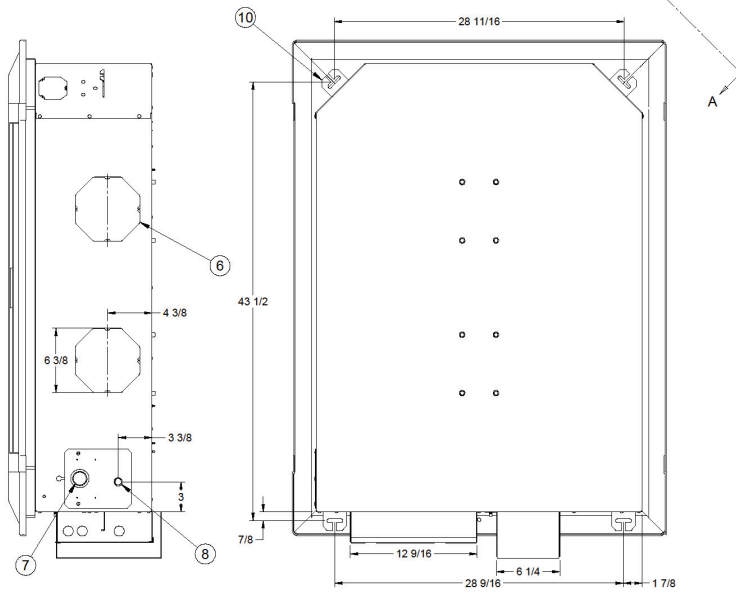

NOTE: Dimensions shown in inches.

Fig. 4 — 42WKN33,36 Dimensions

CONTROLS DESCRIPTION

Microprocessor Control Board

The PCB (printed circuit board) control board relays control the operation of the indoor-fan motor, outdoor-fan motor, compressor and electric heater (if fitted), to maintain room conditions at a user-defined set point. Temperature settings, fan speeds and other control functions can be changed by the infrared (IR) transmitter or optional pendant. The controller PCB provides the following input/output facilities:

Inputs

- T1 Return Air Temperature Sensor: 50K at 77°F
- T3 Indoor Coil Temperature Sensor: 50K at 77°F

Outputs

INDOOR FAN MOTOR

The controller will switch a combination of three 10 amp, 230-vac (3 speed settings) resistive rated relays to deliver the selected indoor fan speed.

CONDENSATE PUMP

The condensate pump will activate when unit is in cooling mode.

VANE MOTOR

A 10 amp, 230-vac resistive rated relay switches the vane motor on when Air Sweep is selected (unit sizes 18-36 only).

ELECTRIC HEAT

A 30 amp, 230-vac resistive rated relay switches the electric heater on when required.

External Connections

- Power input - Nominal 230-vac, 50/60 Hz
- Network connection - Twisted pair shielded cable

Refer to Fig. 5-34 for typical 42WKN unit wiring diagrams.

Microprocessor PCB Battery (P/N CR2032)

The microprocessor PCB is fitted with a battery backup system that maintains the CPU (central processing unit) memory and time clock settings during brief power outages. The battery is small, round and silver in appearance, similar to a wrist watch battery. When the unit is shipped, the battery is packed in a plastic bag and is placed inside the small rectangular box containing the infrared transmitter. The battery should be installed

into the PCB's battery holder approximately 5 minutes before main power is initially applied to the unit.

Controller

Before using the infrared transmitters, please read this handbook fully and ensure the batteries (supplied loose) are fitted into the IR transmitter.

A microprocessor mounted in a metal control box enclosure is used to control the entire unit operating functions with adjustments and settings being made from a hand-held IR transmitter or optional pendant.

The controls include the following basic components:

- PCB control board
- Infrared transmitter or optional pendant
- Infrared receiver (fascia)

See Fig. 35 for controller button and icon information.

Infrared Receiver

The IR receiver (see Fig. 36) is an extension of the control board and is located on the fascia of the unit, connected by a 7-pin plug and socket.

The green on/off indicator will be illuminated when the unit is running.

Yellow indicators show the present unit status, either "cool" or "heat."

When both yellow indicators flash, the PCB control board battery needs to be changed.

NOTE: Be careful not to damage the holder when changing the battery.

Self Diagnostics

The microprocessor controller has a built-in diagnostics feature so that in the event of an alarm, the nature of the fault can be determined. The red timer/alarm LED (light-emitting diode) flashes on the fascia in a pre-determined frequency depending on the fault as identified below:

1. Alarm LED flashes once every second: indoor coil sensor failure, low coil temperature or condensate high level trip.
2. Alarm LED flashes once every 5 seconds: return air sensor failure.

Receiver Indicators

See Fig. 36 on page 38 and "Operation" on page 54 for an explanation of receiver indicators.

230V LINE WIRING: USE COMPONENT LEADS OR 14 AWG BLACK UNLESS NOTED
 24V CONTROL WIRING: USE COMPONENT LEADS OR 18 AWG WHITE

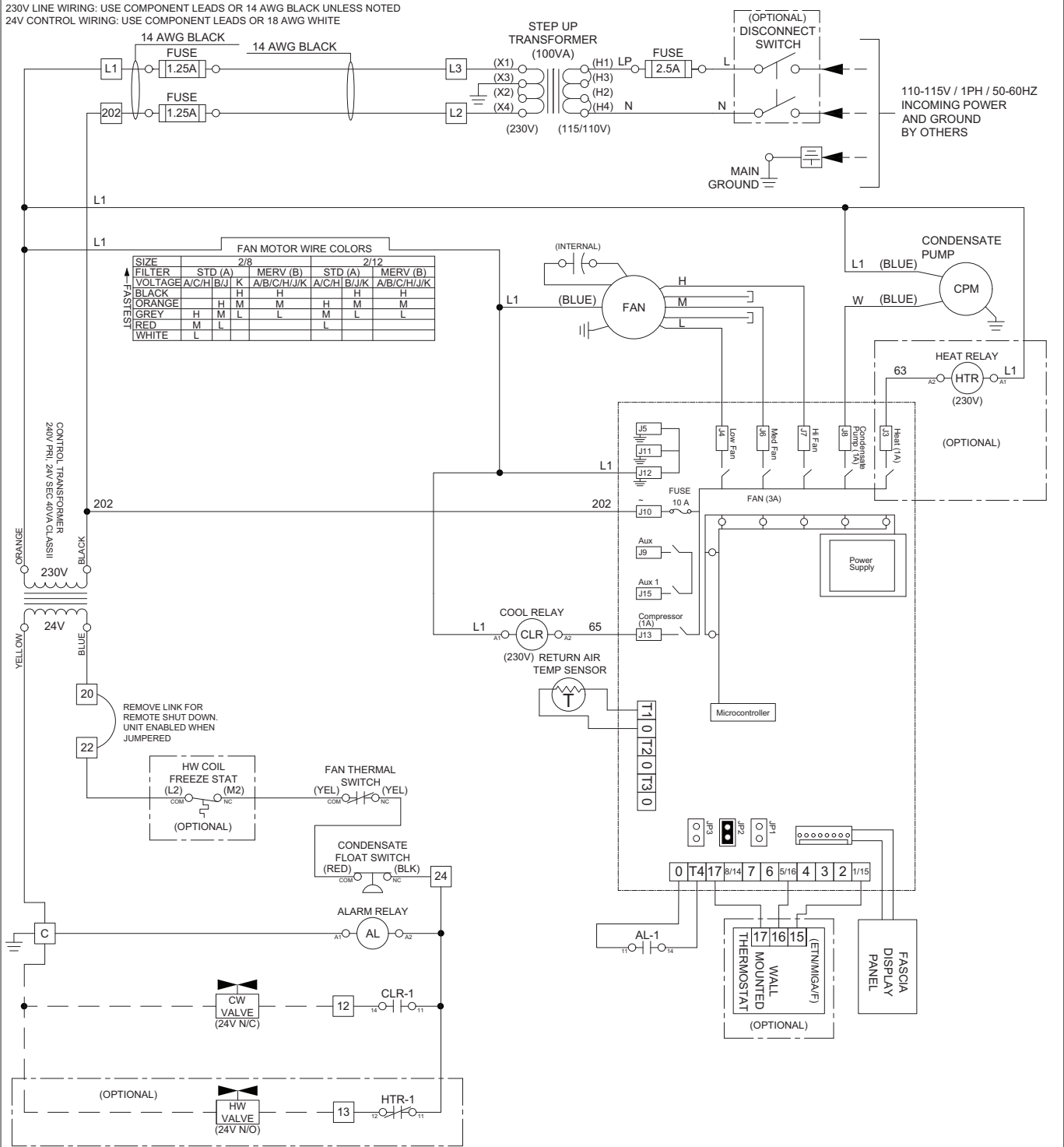

<p>WARNING</p> <p>1) DISCONNECT POWER SUPPLY BEFORE MAKING CONNECTIONS TO PREVENT ELECTRICAL SHOCK AND EQUIPMENT DAMAGE. 2) ALL UNITS MUST BE WIRED STRICTLY IN ACCORDANCE WITH WIRING DIAGRAM FURNISHED WITH THE UNIT. ANY WIRING DIFFERENT FROM THE WIRING DIAGRAM COULD RESULT IN A HAZARD TO PERSONS AND PROPERTY. 3) ANY ORIGINAL FACTORY WIRING THAT REQUIRES REPLACEMENT MUST BE REPLACED WITH WIRING MATERIAL HAVING A TEMPERATURE RATING OF AT LEAST 105°C.</p>	<p>IMPORTANT</p> <p>INSTALLATION OF WIRING MUST CONFORM WITH LOCAL BUILDING CODES OR IN THE ABSENCE OF LOCAL CODES, OF THE NATIONAL ELECTRICAL CODE ANSI/NFPA 70 - LATEST EDITION. UNIT MUST BE ELECTRICALLY GROUNDED IN CONFORMANCE TO THIS CODE. IN CANADA, WIRING MUST COMPLY WITH CSA C22.1, PART 1, ELECTRICAL CODE.</p>	<p>WIRING LEGEND</p> <p>FACTORY INSTALLED ———</p> <p>FIELD INSTALLED - - - - -</p> <p>TERMINAL BLOCK </p> <p>COMPONENT TERMINAL </p> <p>CONNECTED PATH </p> <p>OPTIONAL COMPONENT </p> <p>PLUG AND SOCKET </p>	<p>CHILLED WATER 2 POSITION SMALL CASSETTE MICROPROCESSOR CONTROLS WITH OPTIONAL HOT WATER</p>	
			<p>WIRING DIAGRAM</p> <p>5H104889-1201</p>	

Fig. 5 — 42WKN Unit 2-Pipe Cooling Only or 4-Pipe System with Microprocessor Control Wiring Diagram, 115v, Sizes 08 and 12

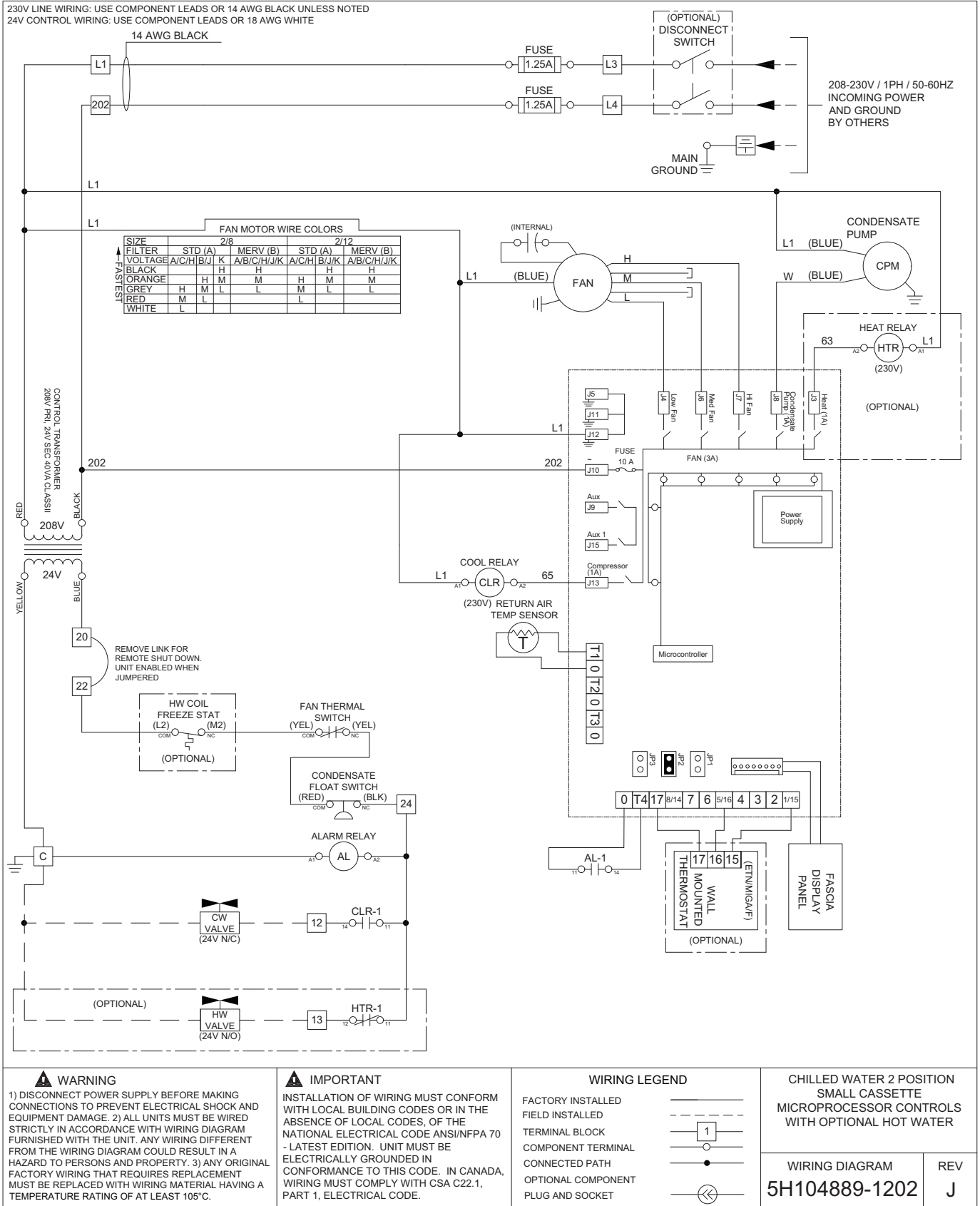
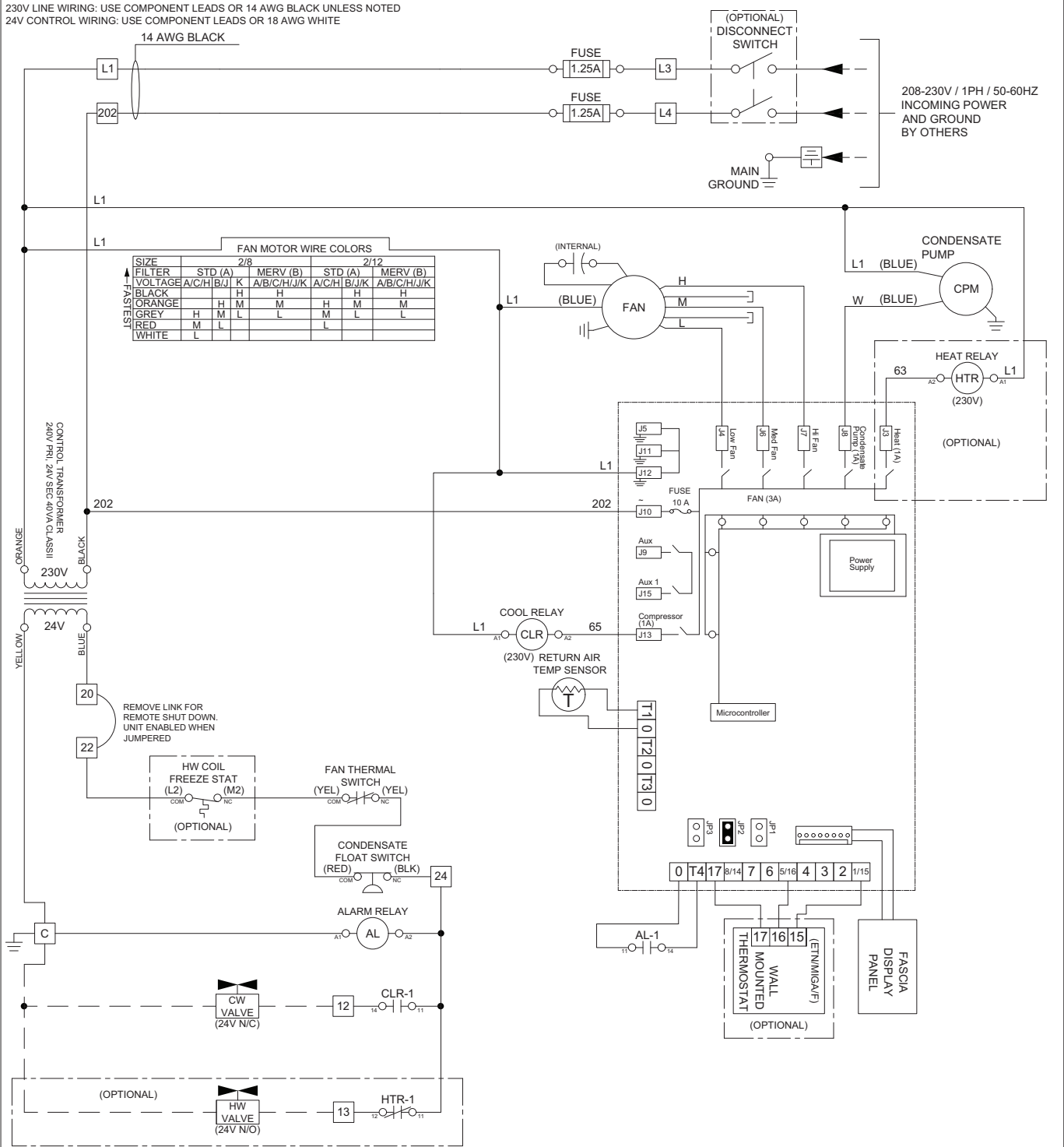

Fig. 6 — 42WKN Unit 2-Pipe Cooling Only or 4-Pipe System with Microprocessor Control Wiring Diagram, 208V, Sizes 08 and 12

230V LINE WIRING: USE COMPONENT LEADS OR 14 AWG BLACK UNLESS NOTED
 24V CONTROL WIRING: USE COMPONENT LEADS OR 18 AWG WHITE



FAN MOTOR WIRE COLORS

SIZE	2/8			2/12		
	STD (A)	MERV (B)		STD (A)	MERV (B)	
VOLTAGE	A/C/H/B/J	K		A/C/H/B/J/K	A/B/C/H/J/K	
BLACK		H	H		H	H
ORANGE	H	M	L	M	H	M
GREY	H	M	L	L	M	L
RED	M	L			L	
WHITE	L	L		L		

WARNING
 1) DISCONNECT POWER SUPPLY BEFORE MAKING CONNECTIONS TO PREVENT ELECTRICAL SHOCK AND EQUIPMENT DAMAGE. 2) ALL UNITS MUST BE WIRED STRICTLY IN ACCORDANCE WITH WIRING DIAGRAM FURNISHED WITH THE UNIT. ANY WIRING DIFFERENT FROM THE WIRING DIAGRAM COULD RESULT IN A HAZARD TO PERSONS AND PROPERTY. 3) ANY ORIGINAL FACTORY WIRING THAT REQUIRES REPLACEMENT MUST BE REPLACED WITH WIRING MATERIAL HAVING A TEMPERATURE RATING OF AT LEAST 105°C.

IMPORTANT
 INSTALLATION OF WIRING MUST CONFORM WITH LOCAL BUILDING CODES OR IN THE ABSENCE OF LOCAL CODES, OF THE NATIONAL ELECTRICAL CODE ANSI/NFPA 70 - LATEST EDITION. UNIT MUST BE ELECTRICALLY GROUNDED IN CONFORMANCE TO THIS CODE. IN CANADA, WIRING MUST COMPLY WITH CSA C22.1, PART 1, ELECTRICAL CODE.

WIRING LEGEND

- FACTORY INSTALLED
- FIELD INSTALLED
- TERMINAL BLOCK
- COMPONENT TERMINAL
- CONNECTED PATH
- OPTIONAL COMPONENT
- PLUG AND SOCKET

CHILLED WATER 2 POSITION SMALL CASSETTE MICROPROCESSOR CONTROLS WITH OPTIONAL HOT WATER

WIRING DIAGRAM
5H104889-1203

REV
J

Fig. 7 — 42WKN Unit 2-Pipe Cooling Only or 4-Pipe System with Microprocessor Control Wiring Diagram, 203v, Sizes 08 and 12

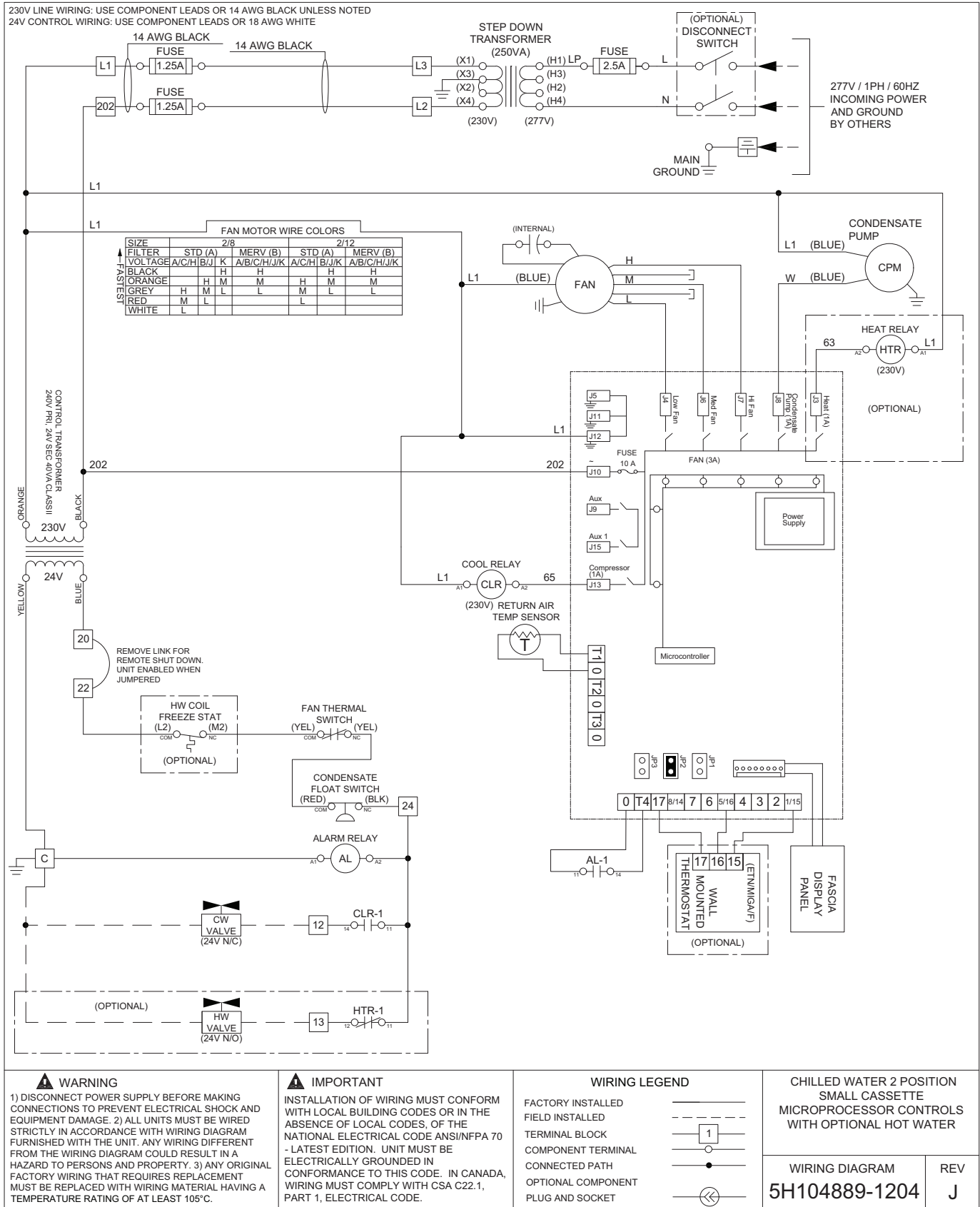
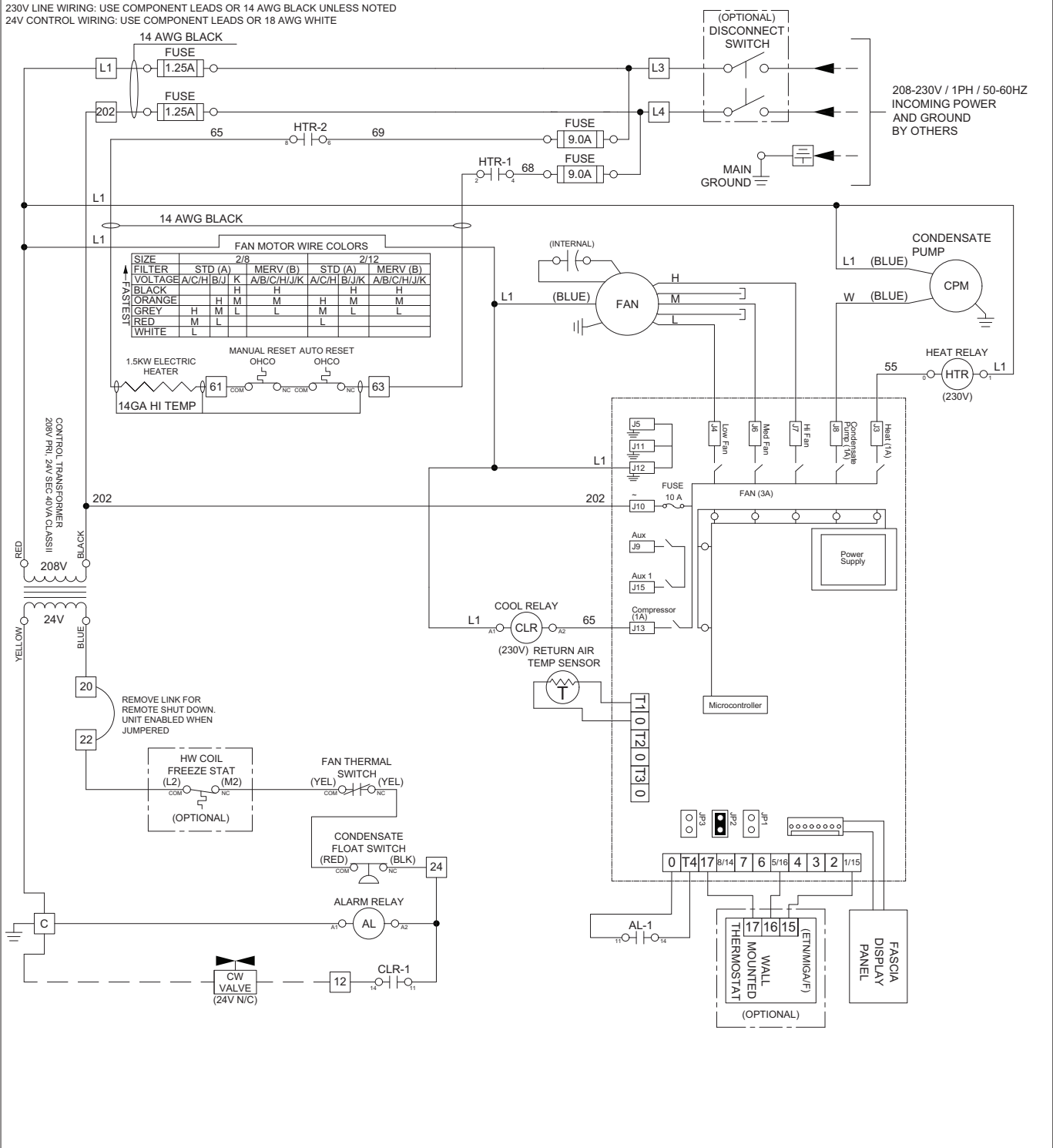

Fig. 8 — 42WKN Unit 2-Pipe Cooling Only or 4-Pipe System with Microprocessor Control Wiring Diagram, 277v, Sizes 08 and 12

230V LINE WIRING: USE COMPONENT LEADS OR 14 AWG BLACK UNLESS NOTED
 24V CONTROL WIRING: USE COMPONENT LEADS OR 18 AWG WHITE



<p>WARNING</p> <p>1) DISCONNECT POWER SUPPLY BEFORE MAKING CONNECTIONS TO PREVENT ELECTRICAL SHOCK AND EQUIPMENT DAMAGE. 2) ALL UNITS MUST BE WIRED STRICTLY IN ACCORDANCE WITH WIRING DIAGRAM FURNISHED WITH THE UNIT. ANY WIRING DIFFERENT FROM THE WIRING DIAGRAM COULD RESULT IN A HAZARD TO PERSONS AND PROPERTY. 3) ANY ORIGINAL FACTORY WIRING THAT REQUIRES REPLACEMENT MUST BE REPLACED WITH WIRING MATERIAL HAVING A TEMPERATURE RATING OF AT LEAST 105°C.</p>	<p>IMPORTANT</p> <p>INSTALLATION OF WIRING MUST CONFORM WITH LOCAL BUILDING CODES OR IN THE ABSENCE OF LOCAL CODES, OF THE NATIONAL ELECTRICAL CODE ANS/NFPA 70 - LATEST EDITION. UNIT MUST BE ELECTRICALLY GROUNDED IN CONFORMANCE TO THIS CODE. IN CANADA, WIRING MUST COMPLY WITH CSA C22.1, PART 1, ELECTRICAL CODE.</p>	<p>WIRING LEGEND</p> <p>FACTORY INSTALLED ———</p> <p>FIELD INSTALLED - - - - -</p> <p>TERMINAL BLOCK </p> <p>COMPONENT TERMINAL </p> <p>CONNECTED PATH </p> <p>OPTIONAL COMPONENT </p> <p>PLUG AND SOCKET </p>	<p>CHILLED WATER 2 POSITION SMALL CASSETTE MICROPROCESSOR CONTROLS WITH ELECTRIC HEAT</p> <table border="1"> <tr> <td>WIRING DIAGRAM</td> <td>REV</td> </tr> <tr> <td>5H104889-1212</td> <td>J</td> </tr> </table>	WIRING DIAGRAM	REV	5H104889-1212	J
WIRING DIAGRAM	REV						
5H104889-1212	J						

Fig. 9 — 42WKN Unit 2-Pipe Cooling with Electric Heat, Microprocessor Control Wiring Diagram, 208v, Sizes 08 and 12

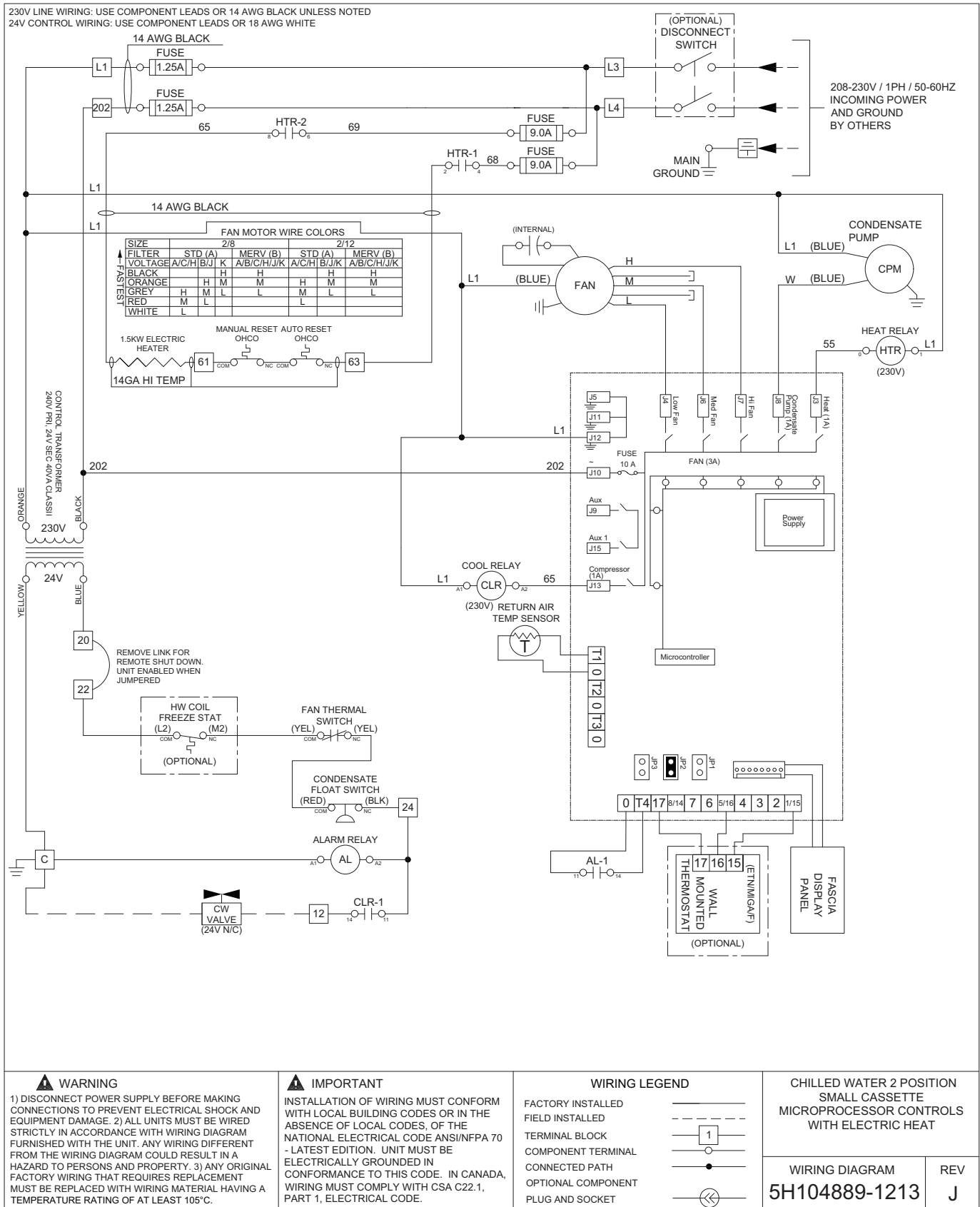
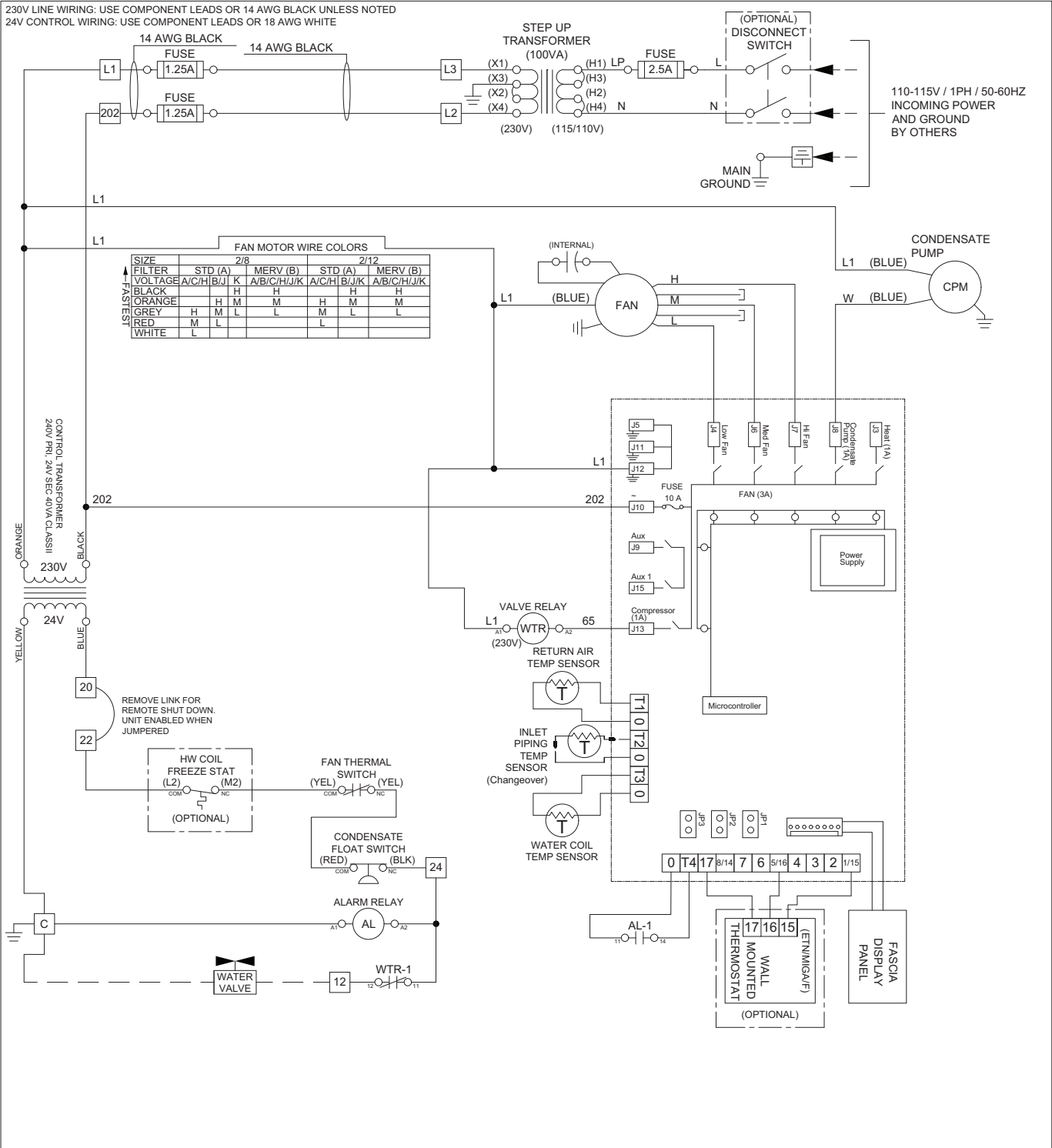

Fig. 10 — 42WKN Unit 2-Pipe Cooling with Electric Heat, Microprocessor Control Wiring Diagram, 230v, Sizes 08 and 12

230V LINE WIRING: USE COMPONENT LEADS OR 14 AWG BLACK UNLESS NOTED
 24V CONTROL WIRING: USE COMPONENT LEADS OR 18 AWG WHITE



<p>WARNING</p> <p>1) DISCONNECT POWER SUPPLY BEFORE MAKING CONNECTIONS TO PREVENT ELECTRICAL SHOCK AND EQUIPMENT DAMAGE. 2) ALL UNITS MUST BE WIRED STRICTLY IN ACCORDANCE WITH WIRING DIAGRAM FURNISHED WITH THE UNIT. ANY WIRING DIFFERENT FROM THE WIRING DIAGRAM COULD RESULT IN A HAZARD TO PERSONS AND PROPERTY. 3) ANY ORIGINAL FACTORY WIRING THAT REQUIRES REPLACEMENT MUST BE REPLACED WITH WIRING MATERIAL HAVING A TEMPERATURE RATING OF AT LEAST 105°C.</p>	<p>IMPORTANT</p> <p>INSTALLATION OF WIRING MUST CONFORM WITH LOCAL BUILDING CODES OR IN THE ABSENCE OF LOCAL CODES, OF THE NATIONAL ELECTRICAL CODE ANSI/NFPA 70 - LATEST EDITION. UNIT MUST BE ELECTRICALLY GROUNDED IN CONFORMANCE TO THIS CODE. IN CANADA, WIRING MUST COMPLY WITH CSA C22.1, PART 1, ELECTRICAL CODE.</p>	<p>WIRING LEGEND</p> <p>FACTORY INSTALLED ———</p> <p>FIELD INSTALLED - - - - -</p> <p>TERMINAL BLOCK </p> <p>COMPONENT TERMINAL </p> <p>CONNECTED PATH </p> <p>OPTIONAL COMPONENT </p> <p>PLUG AND SOCKET </p>	<p>CHILLED WATER 2 POSITION SMALL CASSETTE MICROPROCESSOR CONTROLS CHANGEOVER</p> <table border="1"> <tr> <td>WIRING DIAGRAM</td> <td>REV</td> </tr> <tr> <td>5H104889-1221</td> <td>J</td> </tr> </table>	WIRING DIAGRAM	REV	5H104889-1221	J
WIRING DIAGRAM	REV						
5H104889-1221	J						

Fig. 11 — 42WKN Unit 2-Pipe Heating/Cooling Changeover with Microprocessor Control Wiring Diagram, 115v, Sizes 08 and 12

230V LINE WIRING: USE COMPONENT LEADS OR 14 AWG BLACK UNLESS NOTED
 24V CONTROL WIRING: USE COMPONENT LEADS OR 18 AWG WHITE

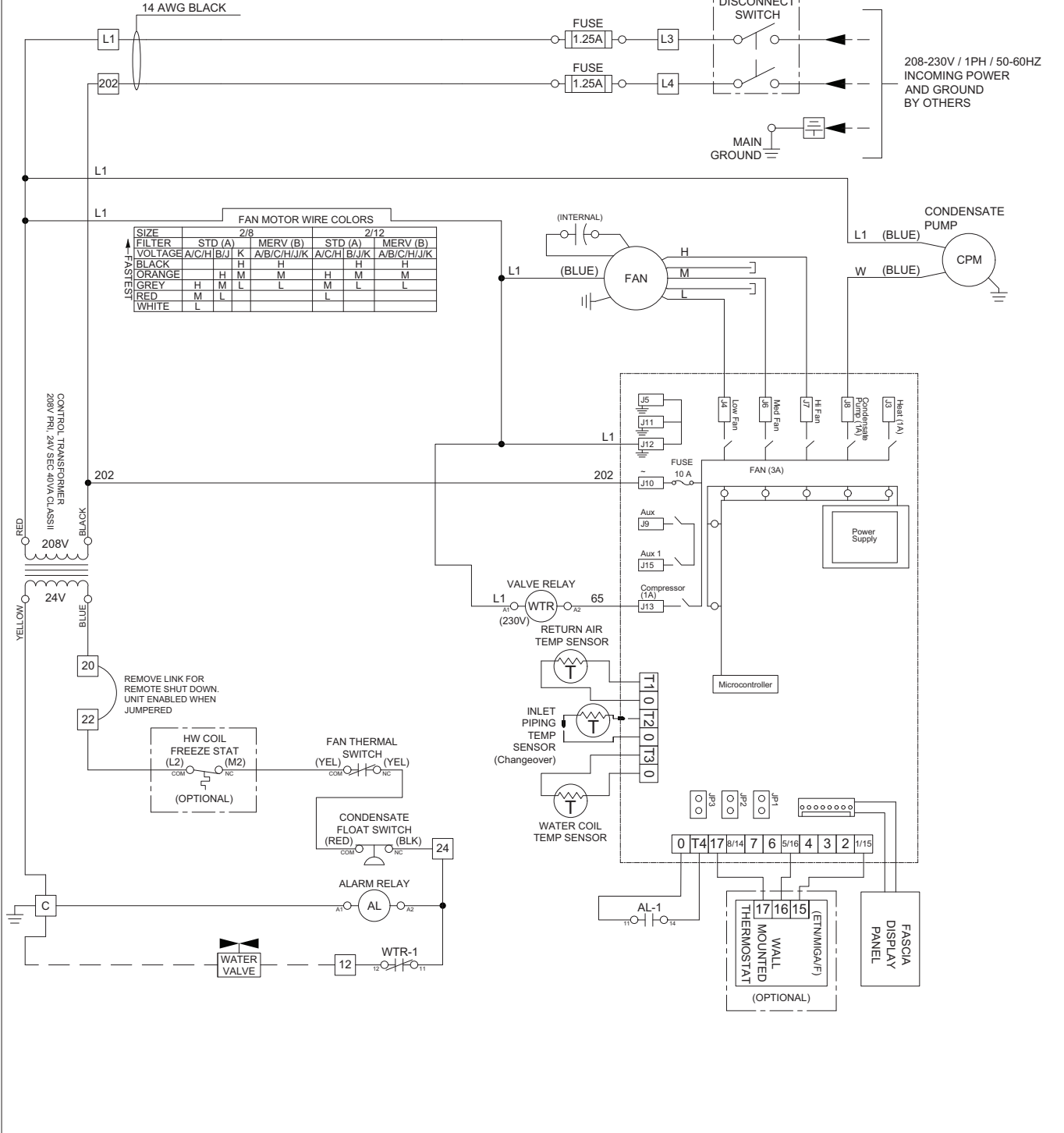

<p>WARNING</p> <p>1) DISCONNECT POWER SUPPLY BEFORE MAKING CONNECTIONS TO PREVENT ELECTRICAL SHOCK AND EQUIPMENT DAMAGE. 2) ALL UNITS MUST BE WIRED STRICTLY IN ACCORDANCE WITH WIRING DIAGRAM FURNISHED WITH THE UNIT. ANY WIRING DIFFERENT FROM THE WIRING DIAGRAM COULD RESULT IN A HAZARD TO PERSONS AND PROPERTY. 3) ANY ORIGINAL FACTORY WIRING THAT REQUIRES REPLACEMENT MUST BE REPLACED WITH WIRING MATERIAL HAVING A TEMPERATURE RATING OF AT LEAST 105°C.</p>	<p>IMPORTANT</p> <p>INSTALLATION OF WIRING MUST CONFORM WITH LOCAL BUILDING CODES OR IN THE ABSENCE OF LOCAL CODES, OF THE NATIONAL ELECTRICAL CODE ANSI/NFPA 70 - LATEST EDITION. UNIT MUST BE ELECTRICALLY GROUNDED IN CONFORMANCE TO THIS CODE. IN CANADA, WIRING MUST COMPLY WITH CSA C22.1, PART 1, ELECTRICAL CODE.</p>	<p>WIRING LEGEND</p> <p>FACTORY INSTALLED ———</p> <p>FIELD INSTALLED - - - - -</p> <p>TERMINAL BLOCK </p> <p>COMPONENT TERMINAL </p> <p>CONNECTED PATH </p> <p>OPTIONAL COMPONENT </p> <p>PLUG AND SOCKET </p>	<p>CHILLED WATER 2 POSITION SMALL CASSETTE MICROPROCESSOR CONTROLS CHANGEOVER</p> <table border="1"> <tr> <td>WIRING DIAGRAM</td> <td>REV</td> </tr> <tr> <td>5H104889-1222</td> <td>J</td> </tr> </table>	WIRING DIAGRAM	REV	5H104889-1222	J
WIRING DIAGRAM	REV						
5H104889-1222	J						

Fig. 12 — 42WKN Unit 2-Pipe Heating/Cooling Changeover with Microprocessor Control Wiring Diagram, 208v, Sizes 08 and 12

230V LINE WIRING: USE COMPONENT LEADS OR 14 AWG BLACK UNLESS NOTED
 24V CONTROL WIRING: USE COMPONENT LEADS OR 18 AWG WHITE

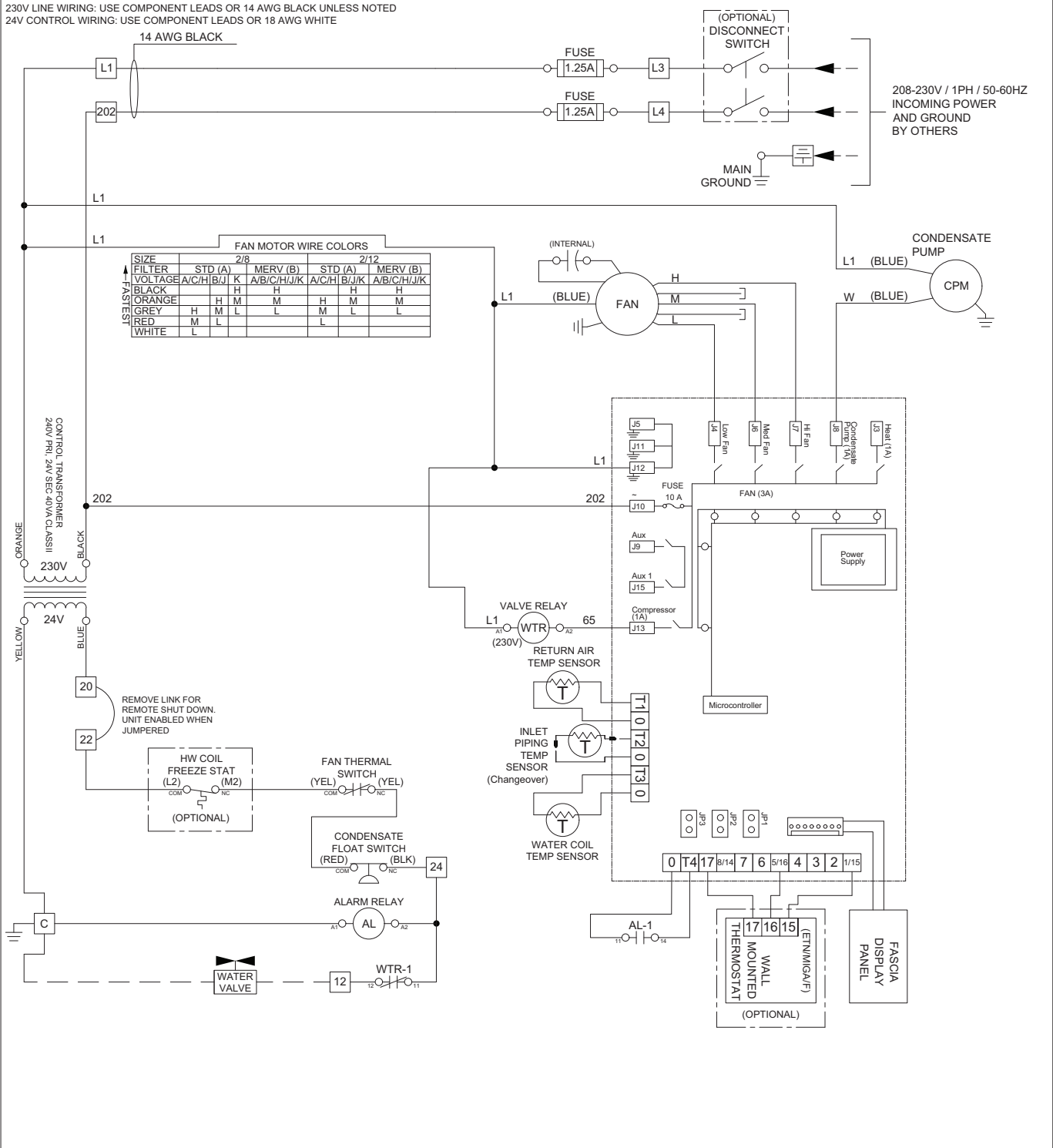

<p>WARNING</p> <p>1) DISCONNECT POWER SUPPLY BEFORE MAKING CONNECTIONS TO PREVENT ELECTRICAL SHOCK AND EQUIPMENT DAMAGE. 2) ALL UNITS MUST BE WIRED STRICTLY IN ACCORDANCE WITH WIRING DIAGRAM FURNISHED WITH THE UNIT. ANY WIRING DIFFERENT FROM THE WIRING DIAGRAM COULD RESULT IN A HAZARD TO PERSONS AND PROPERTY. 3) ANY ORIGINAL FACTORY WIRING THAT REQUIRES REPLACEMENT MUST BE REPLACED WITH WIRING MATERIAL HAVING A TEMPERATURE RATING OF AT LEAST 105°C.</p>	<p>IMPORTANT</p> <p>INSTALLATION OF WIRING MUST CONFORM WITH LOCAL BUILDING CODES OR IN THE ABSENCE OF LOCAL CODES, OF THE NATIONAL ELECTRICAL CODE ANSI/NFPA 70 - LATEST EDITION. UNIT MUST BE ELECTRICALLY GROUNDED IN CONFORMANCE TO THIS CODE. IN CANADA, WIRING MUST COMPLY WITH CSA C22.1, PART 1, ELECTRICAL CODE.</p>	<p>WIRING LEGEND</p> <p>FACTORY INSTALLED ———</p> <p>FIELD INSTALLED - - - - -</p> <p>TERMINAL BLOCK </p> <p>COMPONENT TERMINAL </p> <p>CONNECTED PATH </p> <p>OPTIONAL COMPONENT </p> <p>PLUG AND SOCKET </p>	<p>CHILLED WATER 2 POSITION SMALL CASSETTE MICROPROCESSOR CONTROLS CHANGEOVER</p> <table border="1"> <tr> <td>WIRING DIAGRAM</td> <td>REV</td> </tr> <tr> <td>5H104889-1223</td> <td>J</td> </tr> </table>	WIRING DIAGRAM	REV	5H104889-1223	J
WIRING DIAGRAM	REV						
5H104889-1223	J						

Fig. 13 — 42WKN Unit 2-Pipe Heating/Cooling Changeover with Microprocessor Control Wiring Diagram, 230v, Sizes 08 and 12

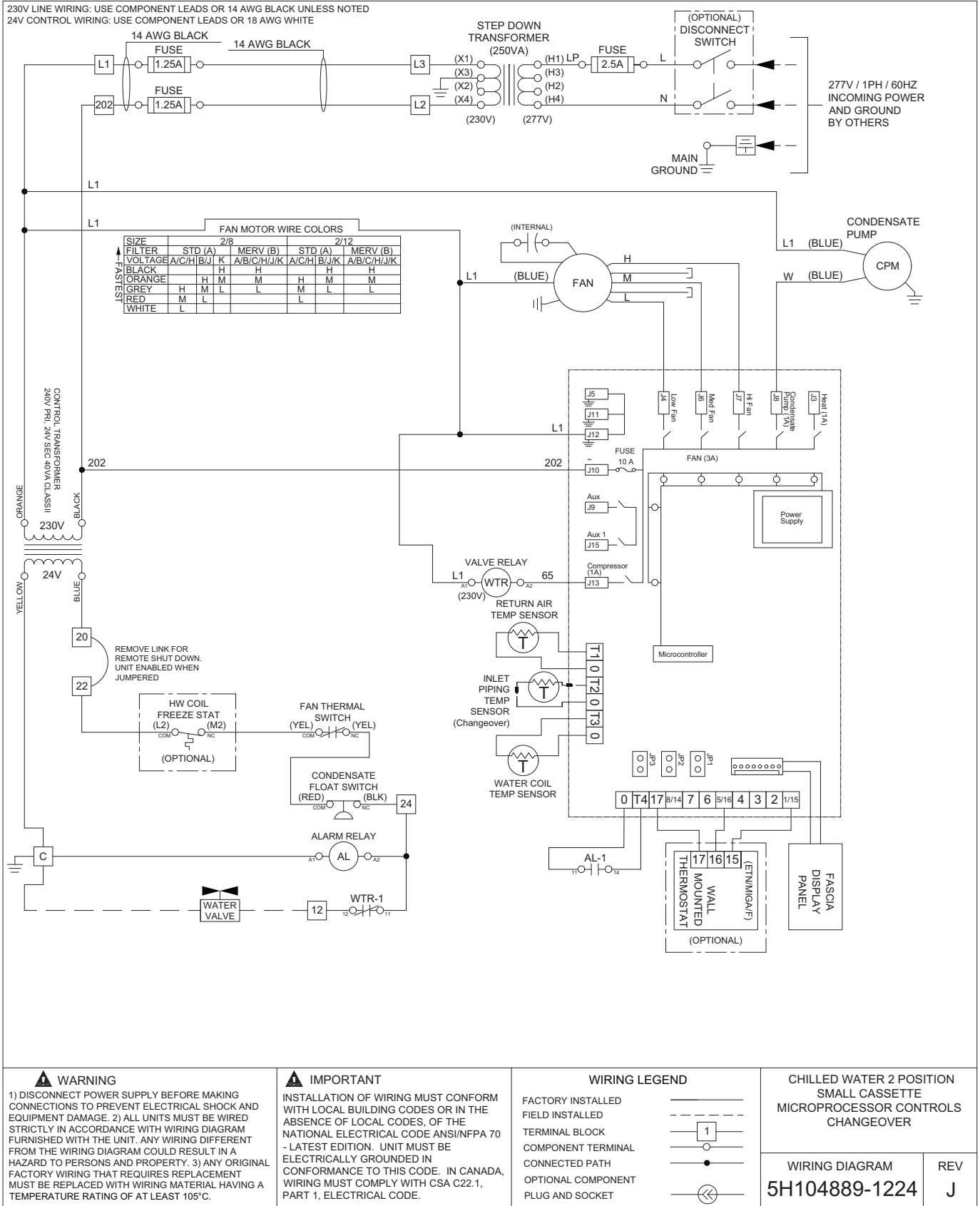

Fig. 14 — 42WKN Unit 2-Pipe Heating/Cooling Changeover with Microprocessor Control Wiring Diagram, 277v, Sizes 08 and 12

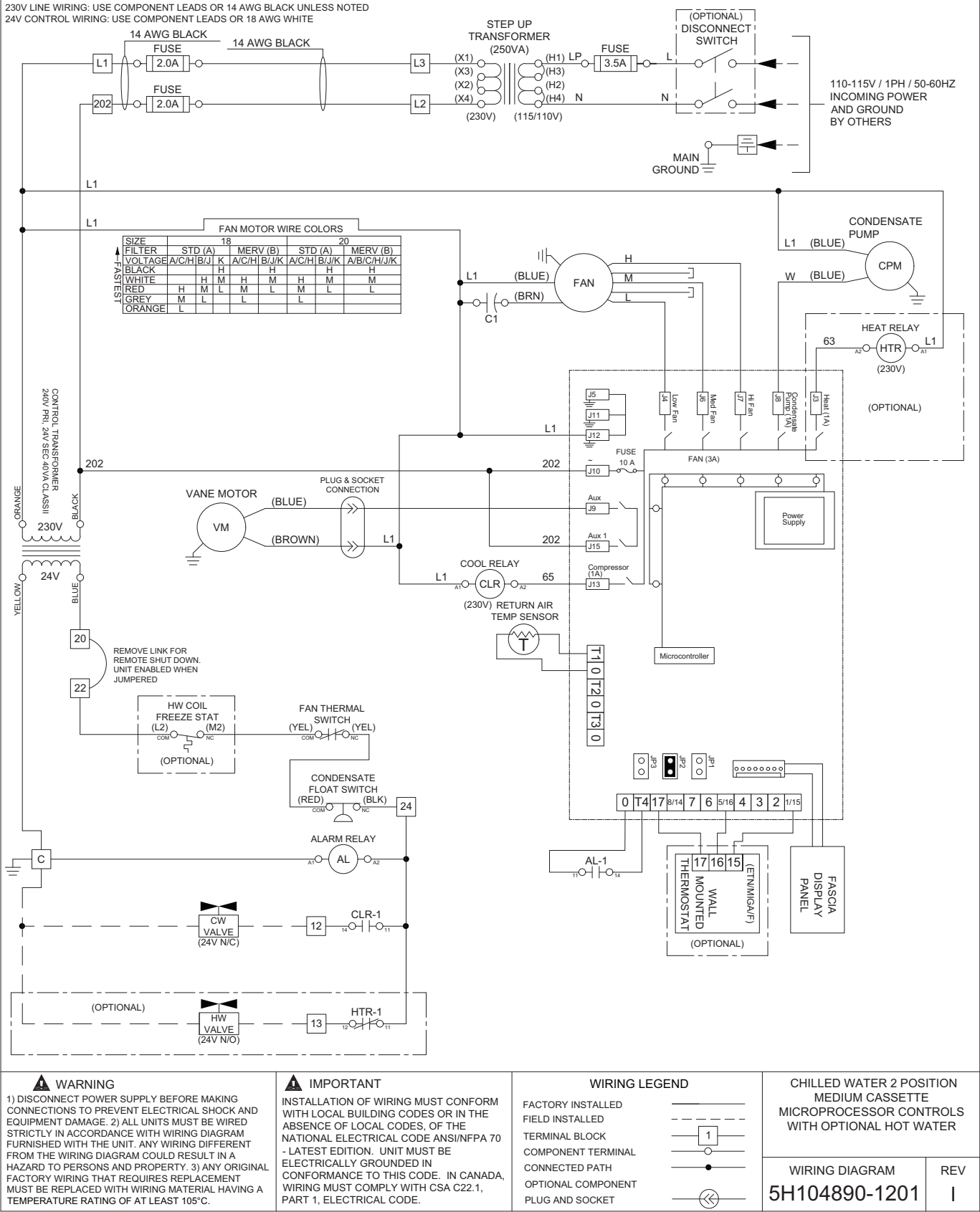

Fig. 15 — 42WKN Unit 2-Pipe Cooling Only or 4-Pipe System with Microprocessor Control Wiring Diagram, 115v, Sizes 18 and 20

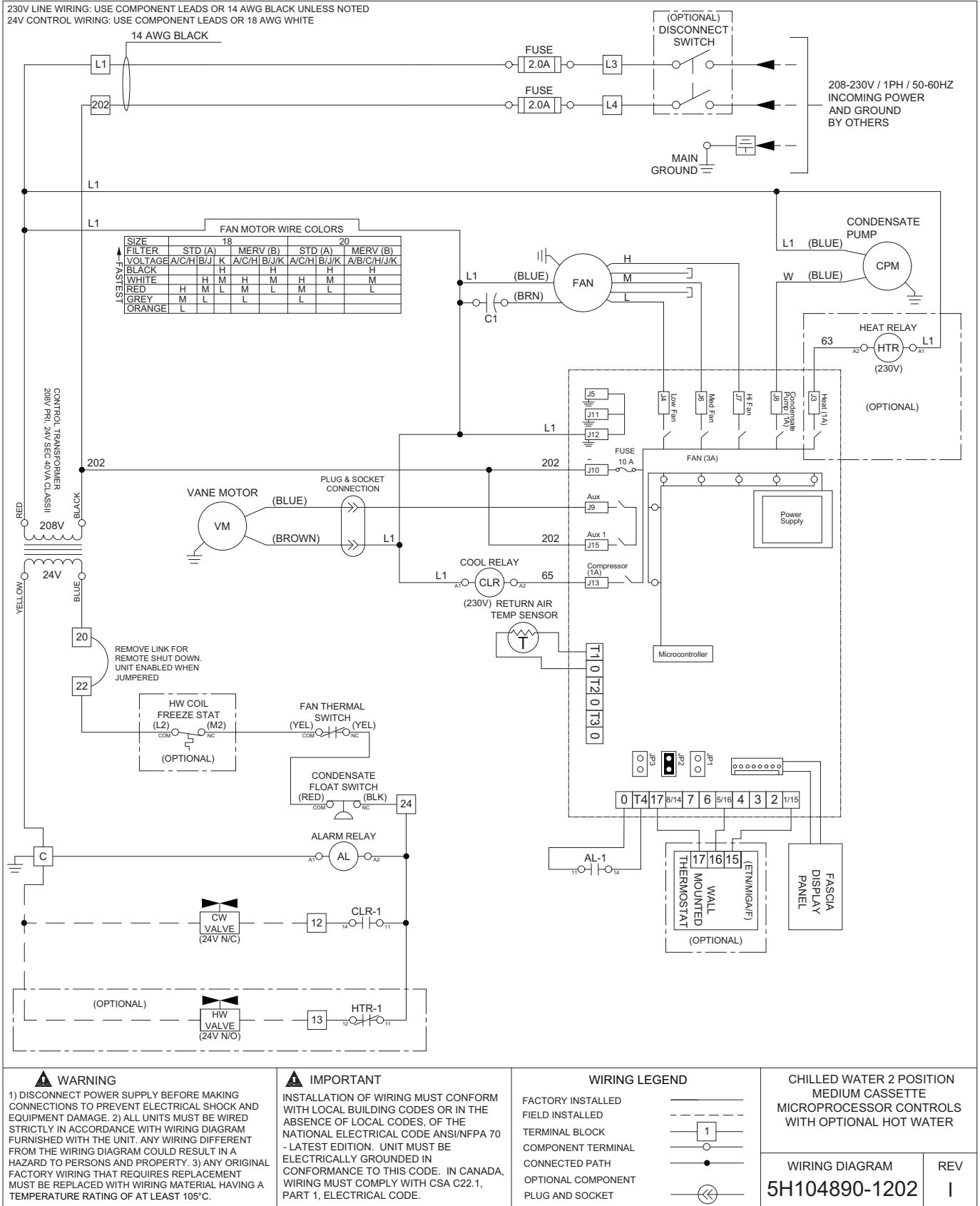
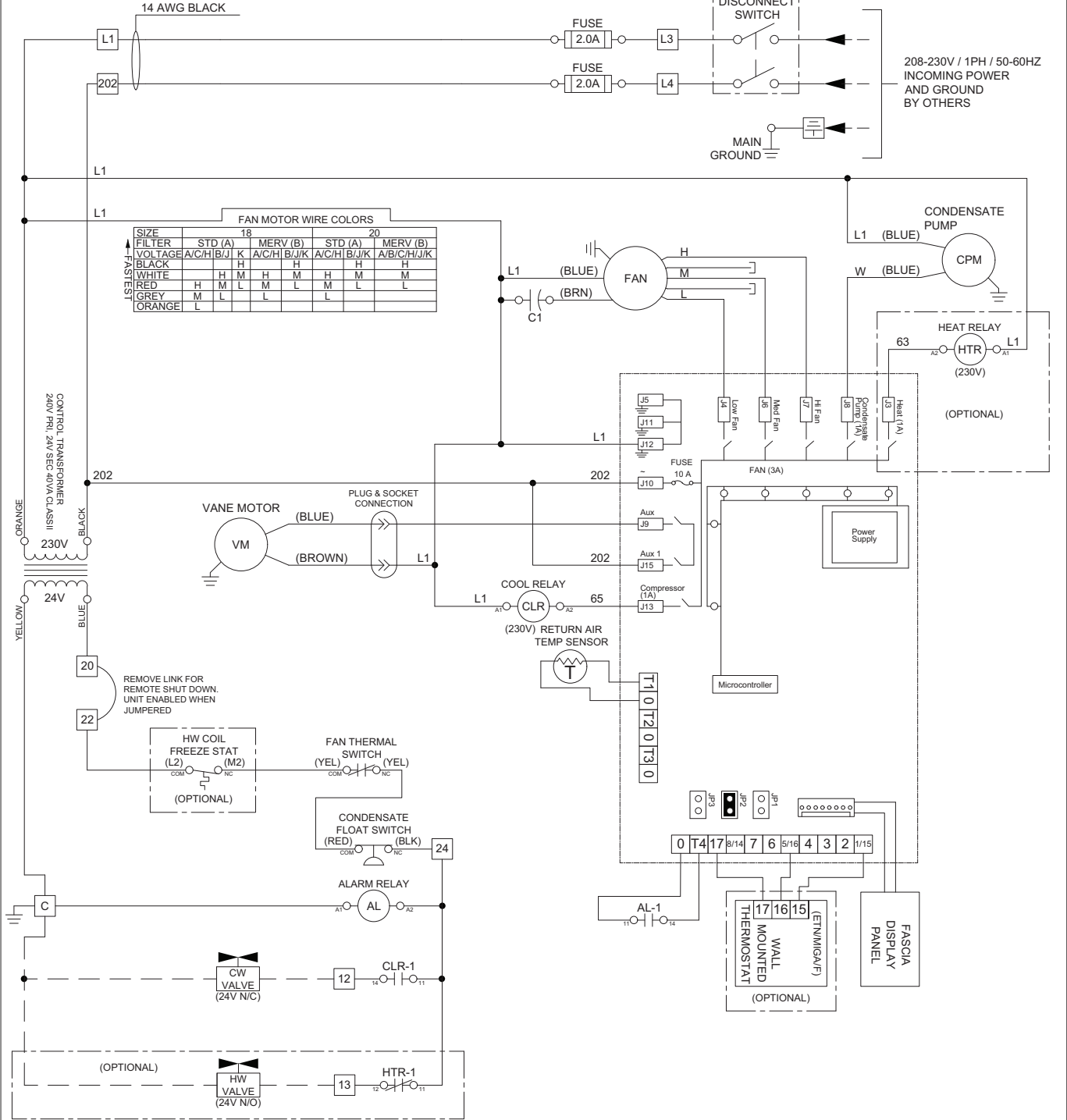

Fig. 16 — 42WKN Unit 2-Pipe Cooling Only or 4-Pipe System with Microprocessor Control Wiring Diagram, 208V, Sizes 18 and 20

230V LINE WIRING: USE COMPONENT LEADS OR 14 AWG BLACK UNLESS NOTED
 24V CONTROL WIRING: USE COMPONENT LEADS OR 18 AWG WHITE



<p>WARNING</p> <p>1) DISCONNECT POWER SUPPLY BEFORE MAKING CONNECTIONS TO PREVENT ELECTRICAL SHOCK AND EQUIPMENT DAMAGE. 2) ALL UNITS MUST BE WIRED STRICTLY IN ACCORDANCE WITH WIRING DIAGRAM FURNISHED WITH THE UNIT. ANY WIRING DIFFERENT FROM THE WIRING DIAGRAM COULD RESULT IN A HAZARD TO PERSONS AND PROPERTY. 3) ANY ORIGINAL FACTORY WIRING THAT REQUIRES REPLACEMENT MUST BE REPLACED WITH WIRING MATERIAL HAVING A TEMPERATURE RATING OF AT LEAST 105°C.</p>	<p>IMPORTANT</p> <p>INSTALLATION OF WIRING MUST CONFORM WITH LOCAL BUILDING CODES OR IN THE ABSENCE OF LOCAL CODES, OF THE NATIONAL ELECTRICAL CODE ANSI/NFPA 70 - LATEST EDITION. UNIT MUST BE ELECTRICALLY GROUNDED IN CONFORMANCE TO THIS CODE. IN CANADA, WIRING MUST COMPLY WITH CSA C22.1, PART 1, ELECTRICAL CODE.</p>	<p>WIRING LEGEND</p> <p>FACTORY INSTALLED ———</p> <p>FIELD INSTALLED - - - - -</p> <p>TERMINAL BLOCK </p> <p>COMPONENT TERMINAL </p> <p>CONNECTED PATH </p> <p>OPTIONAL COMPONENT </p> <p>PLUG AND SOCKET </p>	<p>CHILLED WATER 2 POSITION MEDIUM CASSETTE MICROPROCESSOR CONTROLS WITH OPTIONAL HOT WATER</p> <table border="1"> <tr> <td>WIRING DIAGRAM</td> <td>REV</td> </tr> <tr> <td>5H104890-1203</td> <td>I</td> </tr> </table>	WIRING DIAGRAM	REV	5H104890-1203	I
WIRING DIAGRAM	REV						
5H104890-1203	I						

Fig. 17 — 42WKN Unit 2-Pipe Cooling Only or 4-Pipe System with Microprocessor Control Wiring Diagram, 230V, Sizes 18 and 20

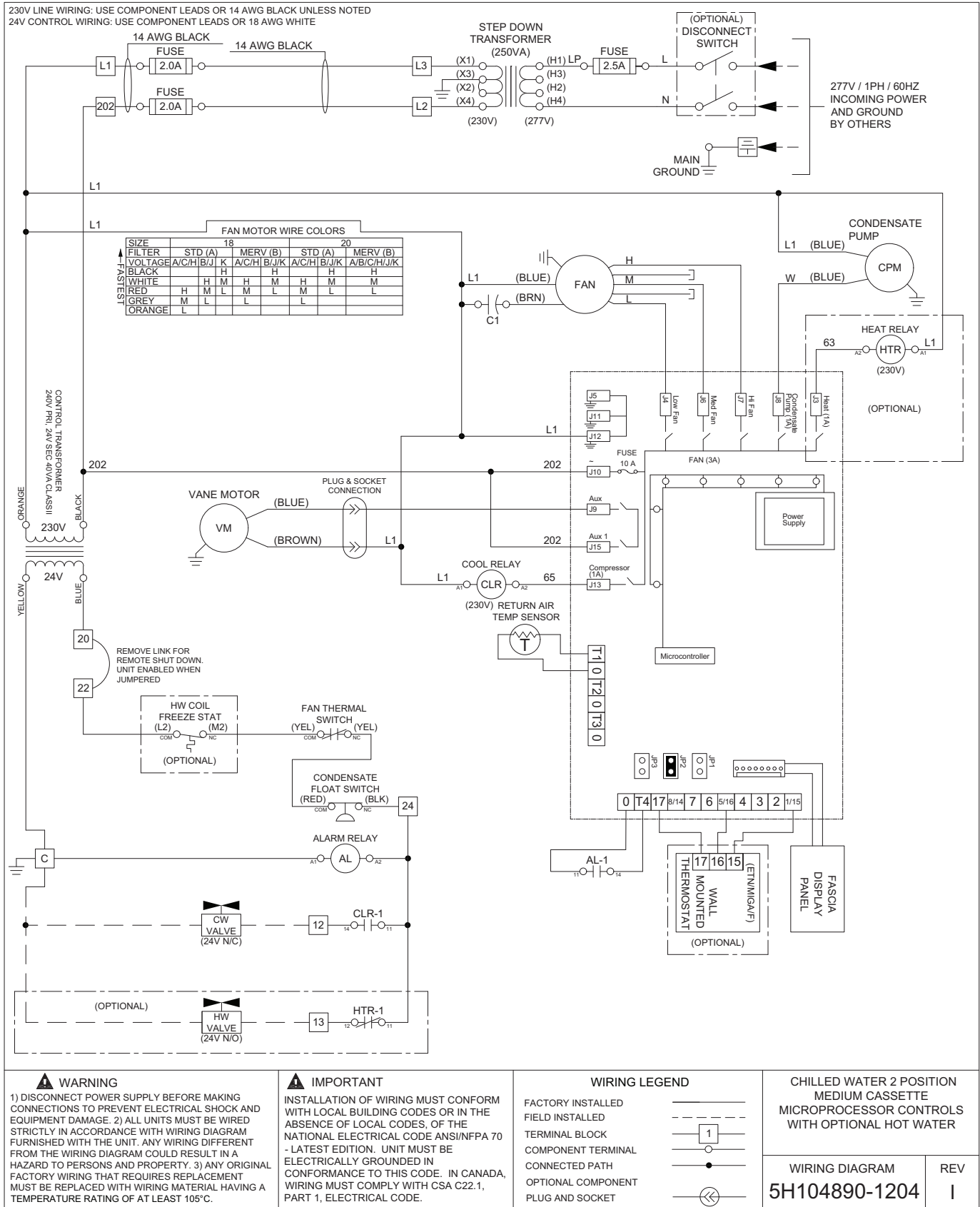
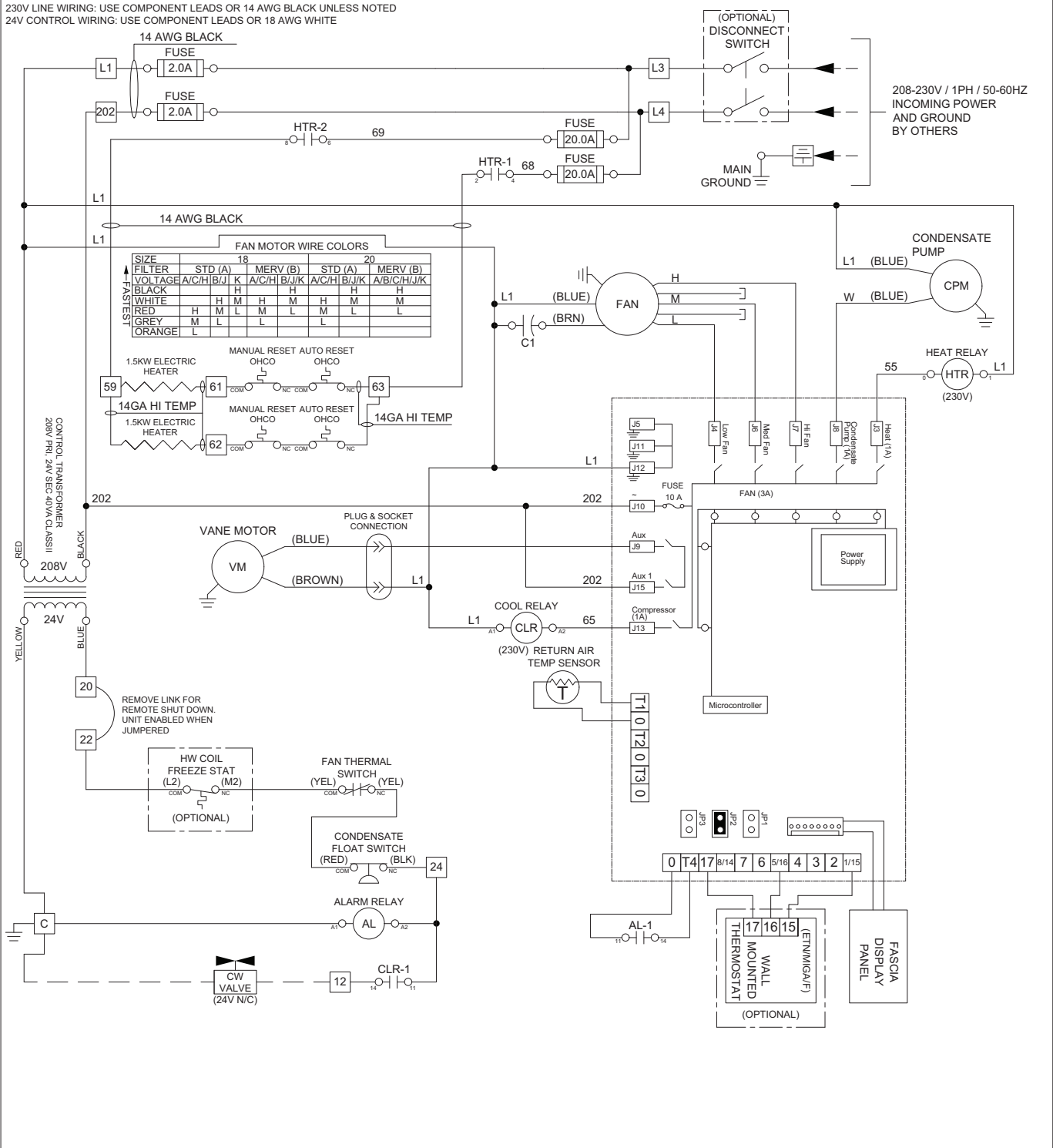

Fig. 18 — 42WKN Unit 2-Pipe Cooling Only or 4-Pipe System with Microprocessor Control Wiring Diagram, 277v, Sizes 18 and 20

230V LINE WIRING: USE COMPONENT LEADS OR 14 AWG BLACK UNLESS NOTED
 24V CONTROL WIRING: USE COMPONENT LEADS OR 18 AWG WHITE



<p>WARNING</p> <p>1) DISCONNECT POWER SUPPLY BEFORE MAKING CONNECTIONS TO PREVENT ELECTRICAL SHOCK AND EQUIPMENT DAMAGE. 2) ALL UNITS MUST BE WIRED STRICTLY IN ACCORDANCE WITH WIRING DIAGRAM FURNISHED WITH THE UNIT. ANY WIRING DIFFERENT FROM THE WIRING DIAGRAM COULD RESULT IN A HAZARD TO PERSONS AND PROPERTY. 3) ANY ORIGINAL FACTORY WIRING THAT REQUIRES REPLACEMENT MUST BE REPLACED WITH WIRING MATERIAL HAVING A TEMPERATURE RATING OF AT LEAST 105°C.</p>	<p>IMPORTANT</p> <p>INSTALLATION OF WIRING MUST CONFORM WITH LOCAL BUILDING CODES OR IN THE ABSENCE OF LOCAL CODES, OF THE NATIONAL ELECTRICAL CODE ANS/NFPA 70 - LATEST EDITION. UNIT MUST BE ELECTRICALLY GROUNDED IN CONFORMANCE TO THIS CODE. IN CANADA, WIRING MUST COMPLY WITH CSA C22.1, PART 1, ELECTRICAL CODE.</p>	<p>WIRING LEGEND</p> <p>FACTORY INSTALLED ———</p> <p>FIELD INSTALLED - - - - -</p> <p>TERMINAL BLOCK </p> <p>COMPONENT TERMINAL </p> <p>CONNECTED PATH </p> <p>OPTIONAL COMPONENT </p> <p>PLUG AND SOCKET </p>	<p>CHILLED WATER 2 POSITION MEDIUM CASSETTE MICROPROCESSOR CONTROLS WITH ELECTRIC HEAT</p>	
			<p>WIRING DIAGRAM</p> <p>5H104890-1212</p>	

Fig. 19 — 42WKN Unit 2-Pipe Cooling Only with Electric Heat, Microprocessor Control Wiring Diagram, 208V, Sizes 18 and 20

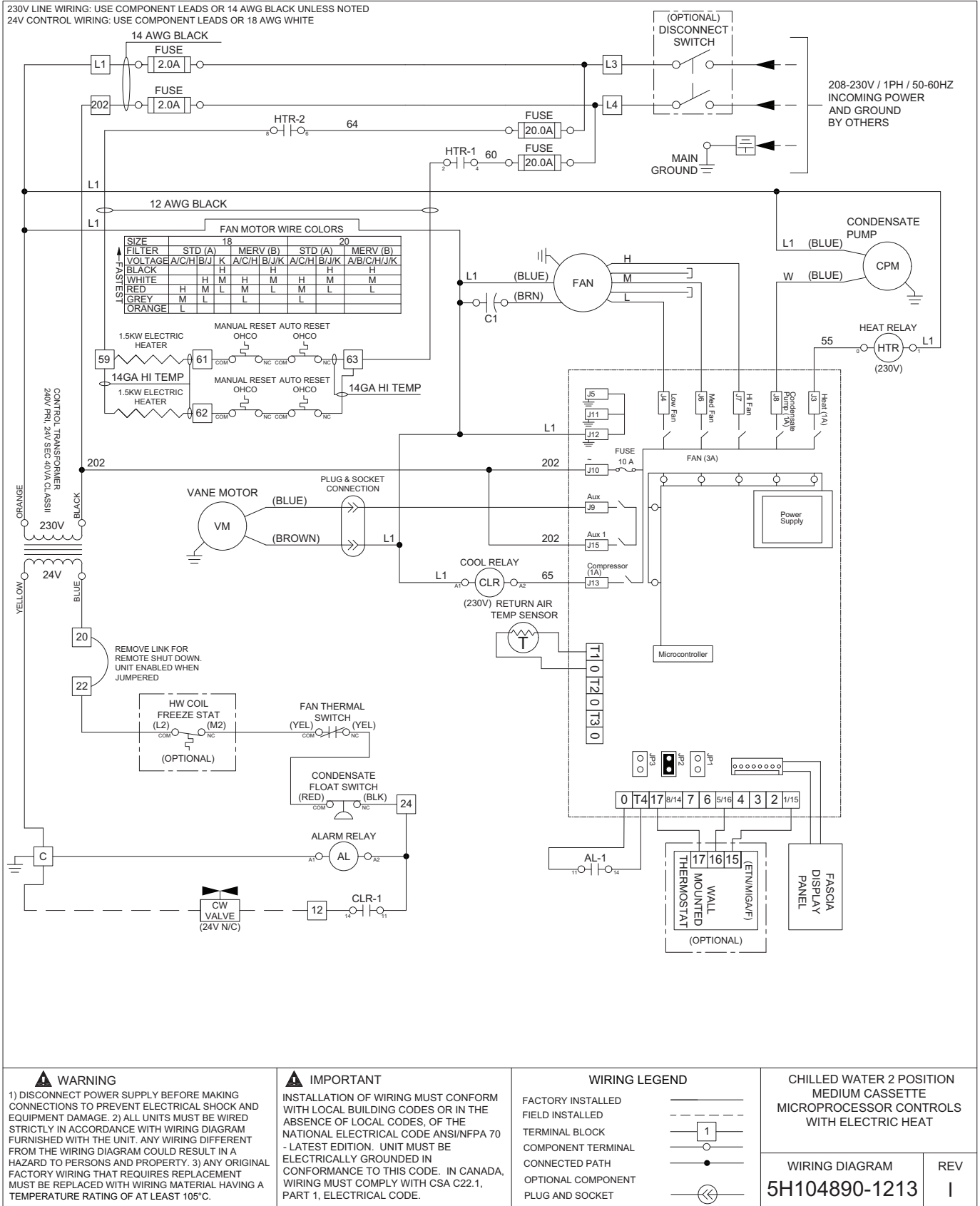
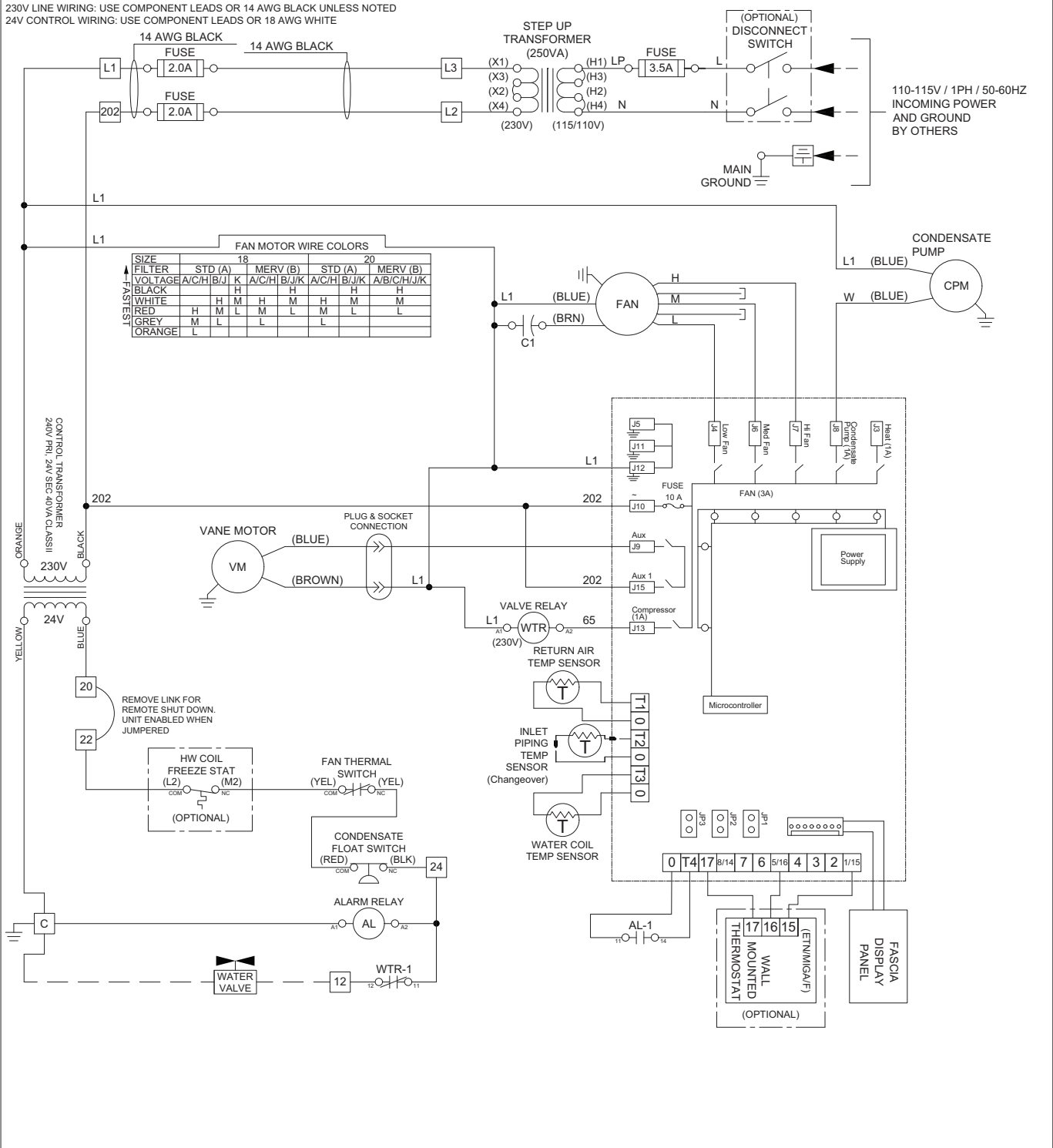

Fig. 20 — 42WKN Unit 2-Pipe Cooling Only with Electric Heat, Microprocessor Control Wiring Diagram, 230v, Sizes 18 and 20

230V LINE WIRING: USE COMPONENT LEADS OR 14 AWG BLACK UNLESS NOTED
 24V CONTROL WIRING: USE COMPONENT LEADS OR 18 AWG WHITE



<p>WARNING</p> <p>1) DISCONNECT POWER SUPPLY BEFORE MAKING CONNECTIONS TO PREVENT ELECTRICAL SHOCK AND EQUIPMENT DAMAGE. 2) ALL UNITS MUST BE WIRED STRICTLY IN ACCORDANCE WITH WIRING DIAGRAM FURNISHED WITH THE UNIT. ANY WIRING DIFFERENT FROM THE WIRING DIAGRAM COULD RESULT IN A HAZARD TO PERSONS AND PROPERTY. 3) ANY ORIGINAL FACTORY WIRING THAT REQUIRES REPLACEMENT MUST BE REPLACED WITH WIRING MATERIAL HAVING A TEMPERATURE RATING OF AT LEAST 105°C.</p>	<p>IMPORTANT</p> <p>INSTALLATION OF WIRING MUST CONFORM WITH LOCAL BUILDING CODES OR IN THE ABSENCE OF LOCAL CODES, OF THE NATIONAL ELECTRICAL CODE ANSI/NFPA 70 - LATEST EDITION. UNIT MUST BE ELECTRICALLY GROUNDED IN CONFORMANCE TO THIS CODE. IN CANADA, WIRING MUST COMPLY WITH CSA C22.1, PART 1, ELECTRICAL CODE.</p>	<p>WIRING LEGEND</p> <p>FACTORY INSTALLED ———</p> <p>FIELD INSTALLED - - - - -</p> <p>TERMINAL BLOCK </p> <p>COMPONENT TERMINAL </p> <p>CONNECTED PATH </p> <p>OPTIONAL COMPONENT </p> <p>PLUG AND SOCKET </p>	<p>CHILLED WATER 2 POSITION MEDIUM CASSETTE MICROPROCESSOR CONTROLS CHANGEOVER</p>	
			<p>WIRING DIAGRAM</p> <p>5H104890-1221</p>	

Fig. 21 — 42WKN Unit 2-Pipe Heating/Cooling Changeover with Microprocessor Control Wiring Diagram, 115v, Sizes 18 and 20

230V LINE WIRING: USE COMPONENT LEADS OR 14 AWG BLACK UNLESS NOTED
 24V CONTROL WIRING: USE COMPONENT LEADS OR 18 AWG WHITE

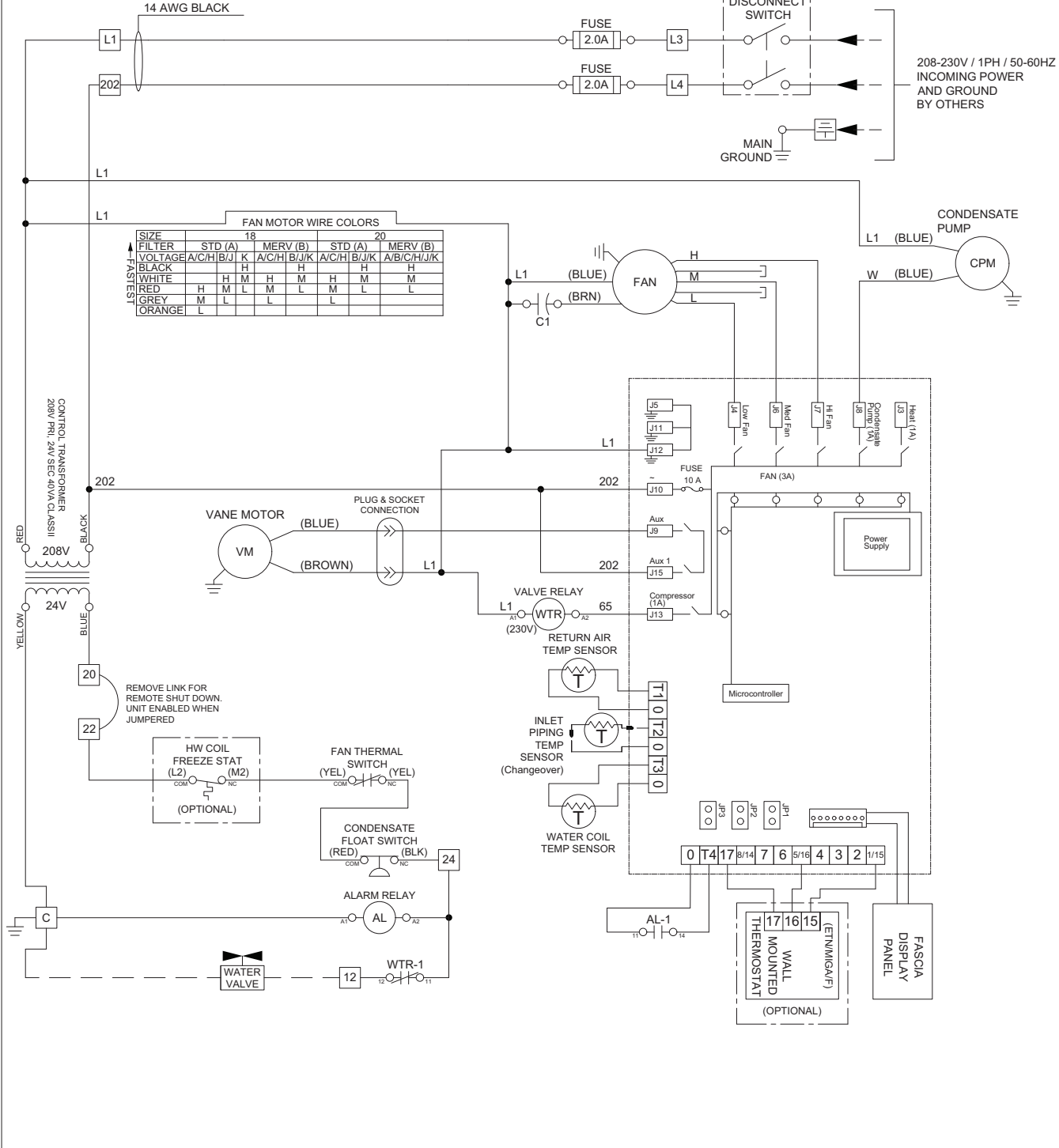

<p>WARNING</p> <p>1) DISCONNECT POWER SUPPLY BEFORE MAKING CONNECTIONS TO PREVENT ELECTRICAL SHOCK AND EQUIPMENT DAMAGE. 2) ALL UNITS MUST BE WIRED STRICTLY IN ACCORDANCE WITH WIRING DIAGRAM FURNISHED WITH THE UNIT. ANY WIRING DIFFERENT FROM THE WIRING DIAGRAM COULD RESULT IN A HAZARD TO PERSONS AND PROPERTY. 3) ANY ORIGINAL FACTORY WIRING THAT REQUIRES REPLACEMENT MUST BE REPLACED WITH WIRING MATERIAL HAVING A TEMPERATURE RATING OF AT LEAST 105°C.</p>	<p>IMPORTANT</p> <p>INSTALLATION OF WIRING MUST CONFORM WITH LOCAL BUILDING CODES OR IN THE ABSENCE OF LOCAL CODES, OF THE NATIONAL ELECTRICAL CODE ANSI/NFPA 70 - LATEST EDITION. UNIT MUST BE ELECTRICALLY GROUNDED IN CONFORMANCE TO THIS CODE. IN CANADA, WIRING MUST COMPLY WITH CSA C22.1, PART 1, ELECTRICAL CODE.</p>	<p>WIRING LEGEND</p> <p>FACTORY INSTALLED ———</p> <p>FIELD INSTALLED - - - - -</p> <p>TERMINAL BLOCK </p> <p>COMPONENT TERMINAL </p> <p>CONNECTED PATH </p> <p>OPTIONAL COMPONENT </p> <p>PLUG AND SOCKET </p>	<p>CHILLED WATER 2 POSITION MEDIUM CASSETTE MICROPROCESSOR CONTROLS CHANGEOVER</p> <table border="1"> <tr> <td>WIRING DIAGRAM</td> <td>REV</td> </tr> <tr> <td>5H104890-1222</td> <td>I</td> </tr> </table>	WIRING DIAGRAM	REV	5H104890-1222	I
WIRING DIAGRAM	REV						
5H104890-1222	I						

Fig. 22 — 42WKN Unit 2-Pipe Heating/Cooling Changeover with Microprocessor Control Wiring Diagram, 208v, Sizes 18 and 20

230V LINE WIRING: USE COMPONENT LEADS OR 14 AWG BLACK UNLESS NOTED
 24V CONTROL WIRING: USE COMPONENT LEADS OR 18 AWG WHITE

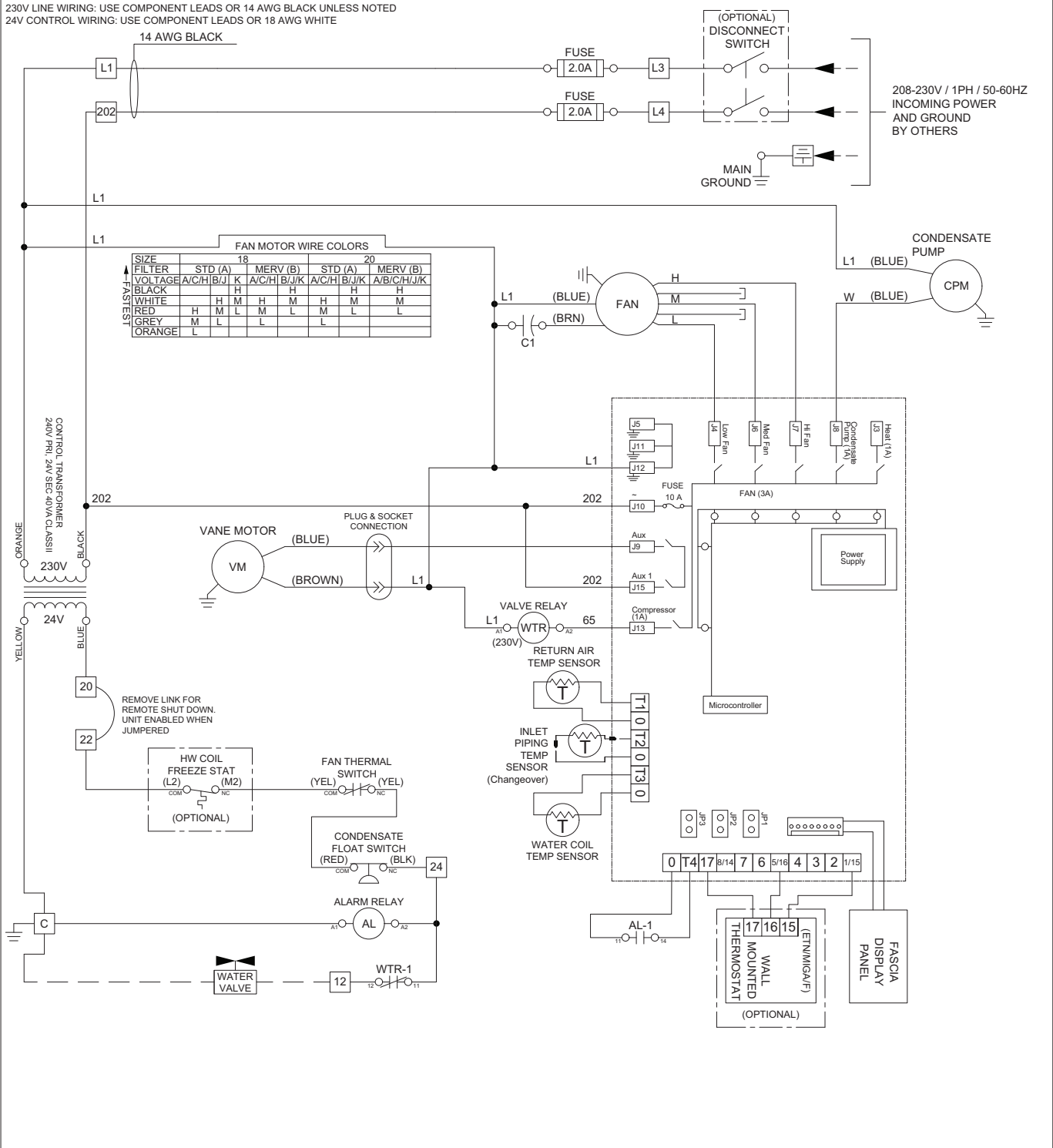

<p>WARNING</p> <p>1) DISCONNECT POWER SUPPLY BEFORE MAKING CONNECTIONS TO PREVENT ELECTRICAL SHOCK AND EQUIPMENT DAMAGE. 2) ALL UNITS MUST BE WIRED STRICTLY IN ACCORDANCE WITH WIRING DIAGRAM FURNISHED WITH THE UNIT. ANY WIRING DIFFERENT FROM THE WIRING DIAGRAM COULD RESULT IN A HAZARD TO PERSONS AND PROPERTY. 3) ANY ORIGINAL FACTORY WIRING THAT REQUIRES REPLACEMENT MUST BE REPLACED WITH WIRING MATERIAL HAVING A TEMPERATURE RATING OF AT LEAST 105°C.</p>	<p>IMPORTANT</p> <p>INSTALLATION OF WIRING MUST CONFORM WITH LOCAL BUILDING CODES OR IN THE ABSENCE OF LOCAL CODES, OF THE NATIONAL ELECTRICAL CODE ANSI/NFPA 70 - LATEST EDITION. UNIT MUST BE ELECTRICALLY GROUNDED IN CONFORMANCE TO THIS CODE. IN CANADA, WIRING MUST COMPLY WITH CSA C22.1, PART 1, ELECTRICAL CODE.</p>	<p>WIRING LEGEND</p> <p>FACTORY INSTALLED ———</p> <p>FIELD INSTALLED - - - - -</p> <p>TERMINAL BLOCK </p> <p>COMPONENT TERMINAL </p> <p>CONNECTED PATH </p> <p>OPTIONAL COMPONENT </p> <p>PLUG AND SOCKET </p>	<p>CHILLED WATER 2 POSITION MEDIUM CASSETTE MICROPROCESSOR CONTROLS CHANGEOVER</p>	
			<p>WIRING DIAGRAM</p> <p>5H104890-1223</p>	

Fig. 23 — 42WKN Unit 2-Pipe Heating/Cooling Changeover with Microprocessor Control Wiring Diagram, 230v, Sizes 18 and 20

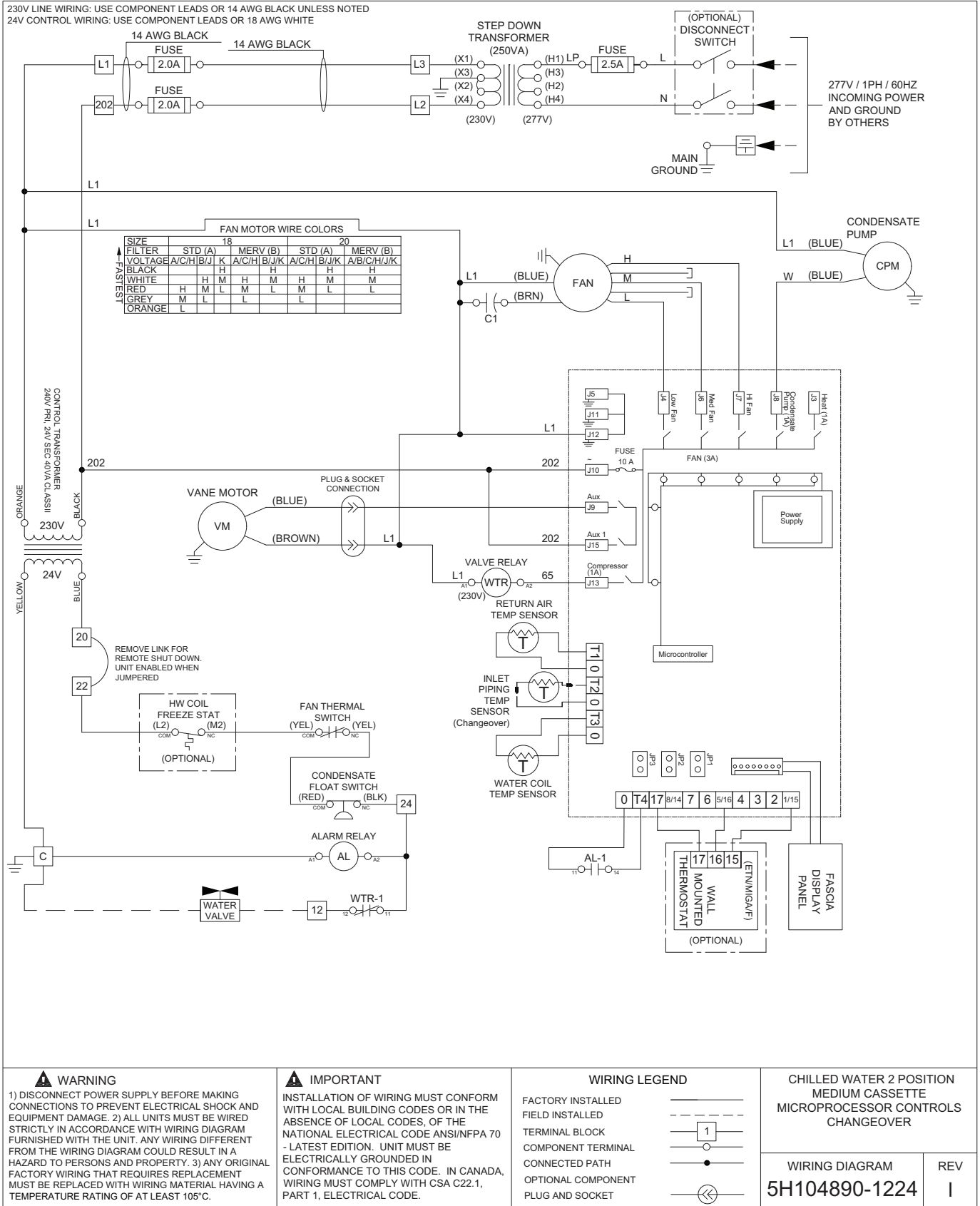
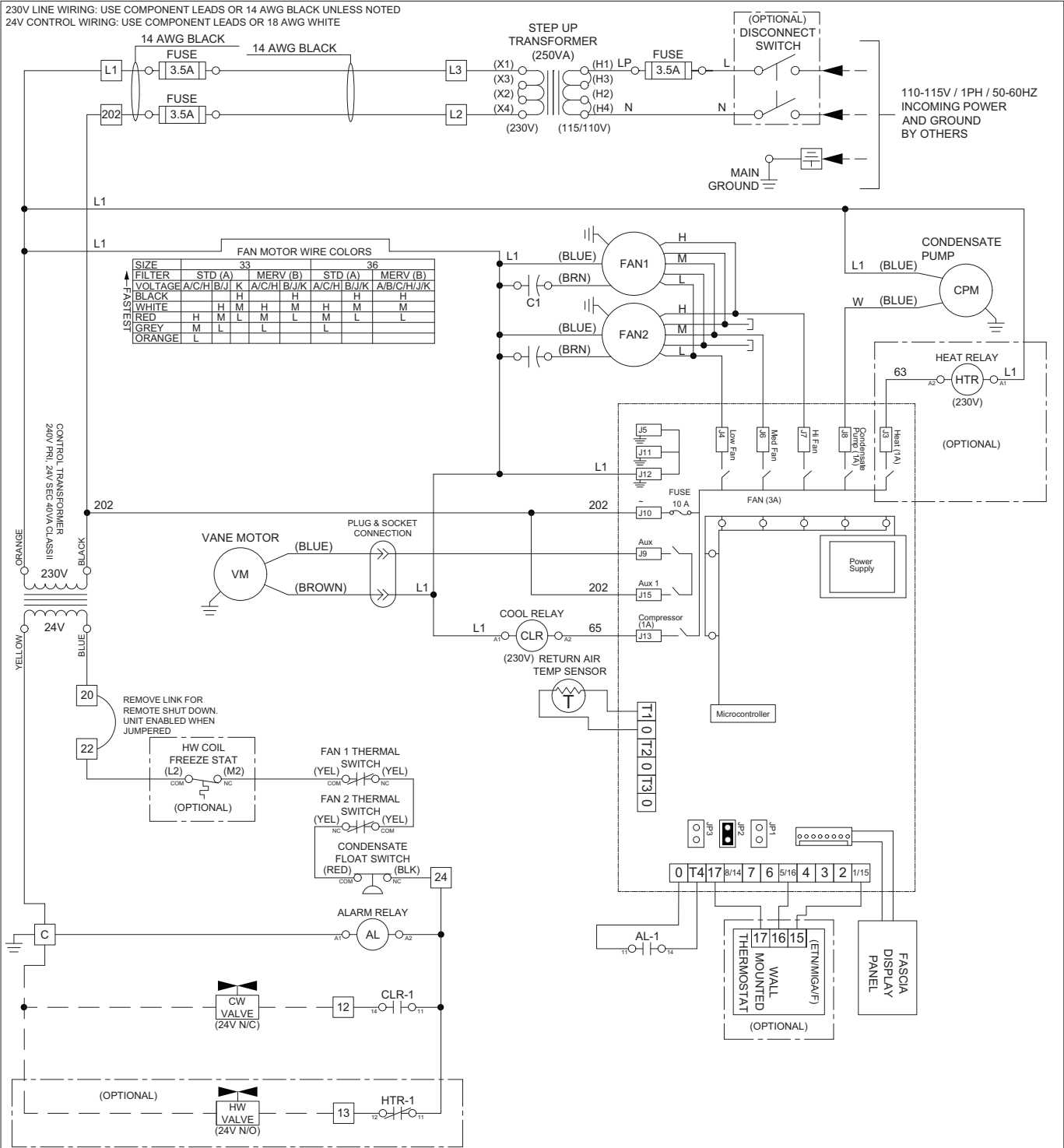

Fig. 24 — 42WKN Unit 2-Pipe Heating/Cooling Changeover with Microprocessor Control Wiring Diagram, 277v, Sizes 18 and 20

230V LINE WIRING: USE COMPONENT LEADS OR 14 AWG BLACK UNLESS NOTED
 24V CONTROL WIRING: USE COMPONENT LEADS OR 18 AWG WHITE



<p>WARNING</p> <p>1) DISCONNECT POWER SUPPLY BEFORE MAKING CONNECTIONS TO PREVENT ELECTRICAL SHOCK AND EQUIPMENT DAMAGE. 2) ALL UNITS MUST BE WIRED STRICTLY IN ACCORDANCE WITH WIRING DIAGRAM FURNISHED WITH THE UNIT. ANY WIRING DEVIATION FROM THE WIRING DIAGRAM COULD RESULT IN A HAZARD TO PERSONS AND PROPERTY. 3) ANY ORIGINAL FACTORY WIRING THAT REQUIRES REPLACEMENT MUST BE REPLACED WITH WIRING MATERIAL HAVING A TEMPERATURE RATING OF AT LEAST 105°C.</p>	<p>IMPORTANT</p> <p>INSTALLATION OF WIRING MUST CONFORM WITH LOCAL BUILDING CODES OR IN THE ABSENCE OF LOCAL CODES, OF THE NATIONAL ELECTRICAL CODE ANSI/NFPA 70 - LATEST EDITION. UNIT MUST BE ELECTRICALLY GROUNDED IN CONFORMANCE TO THIS CODE. IN CANADA, WIRING MUST COMPLY WITH CSA C22.1, PART 1, ELECTRICAL CODE.</p>	<p>WIRING LEGEND</p> <p>FACTORY INSTALLED ———</p> <p>FIELD INSTALLED - - - - -</p> <p>TERMINAL BLOCK </p> <p>COMPONENT TERMINAL </p> <p>CONNECTED PATH </p> <p>OPTIONAL COMPONENT </p> <p>PLUG AND SOCKET </p>	<p>CHILLED WATER 2 POSITION LARGE CASSETTE MICROPROCESSOR CONTROLS WITH OPTIONAL HOT WATER</p> <table border="1"> <tr> <td>WIRING DIAGRAM</td> <td>REV</td> </tr> <tr> <td>5H104891-1201</td> <td>I</td> </tr> </table>	WIRING DIAGRAM	REV	5H104891-1201	I
WIRING DIAGRAM	REV						
5H104891-1201	I						

Fig. 25 — 42WKN Unit 2-Pipe Cooling Only or 4-Pipe System with Microprocessor Control Wiring Diagram, 115v, Sizes 33 and 36

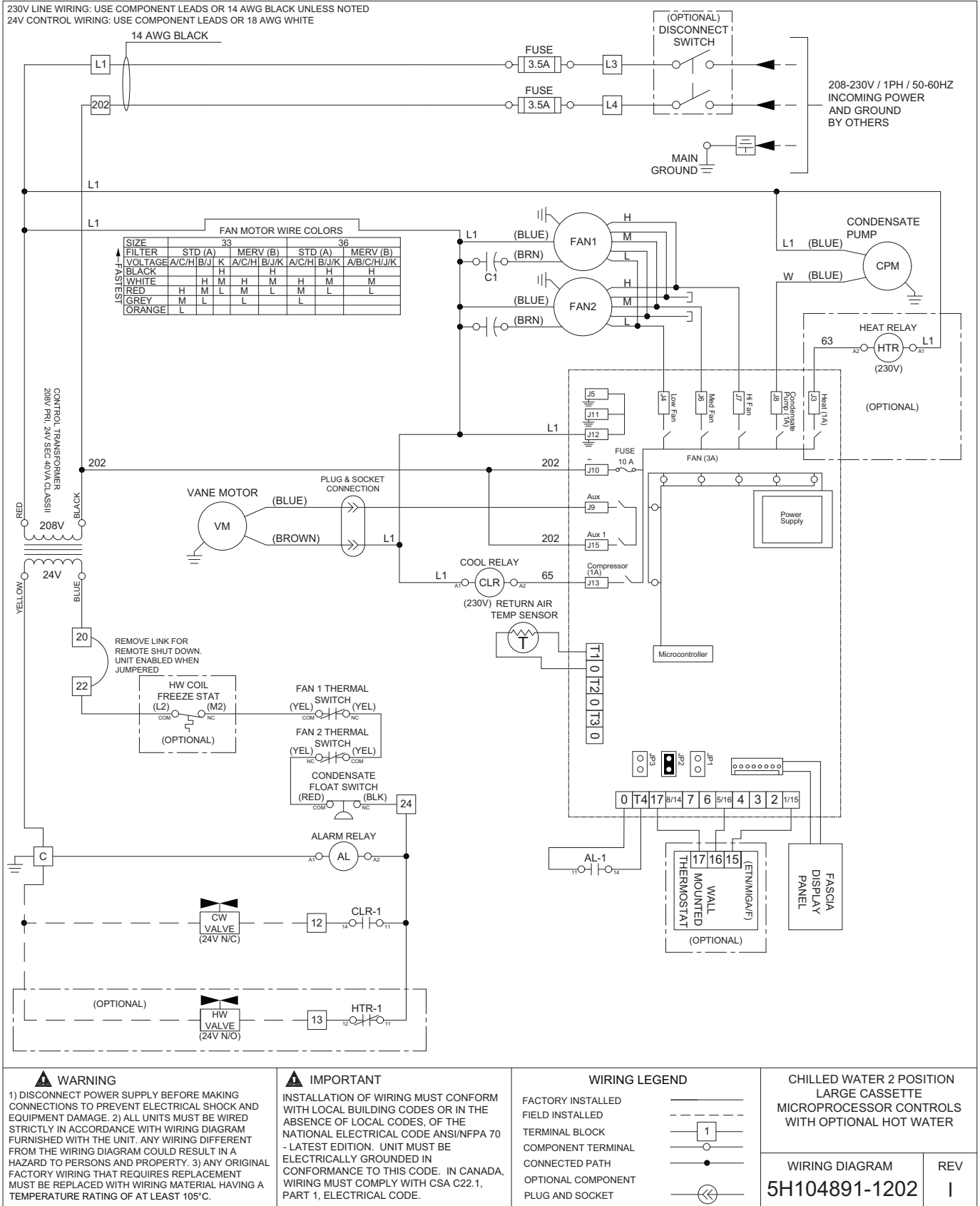
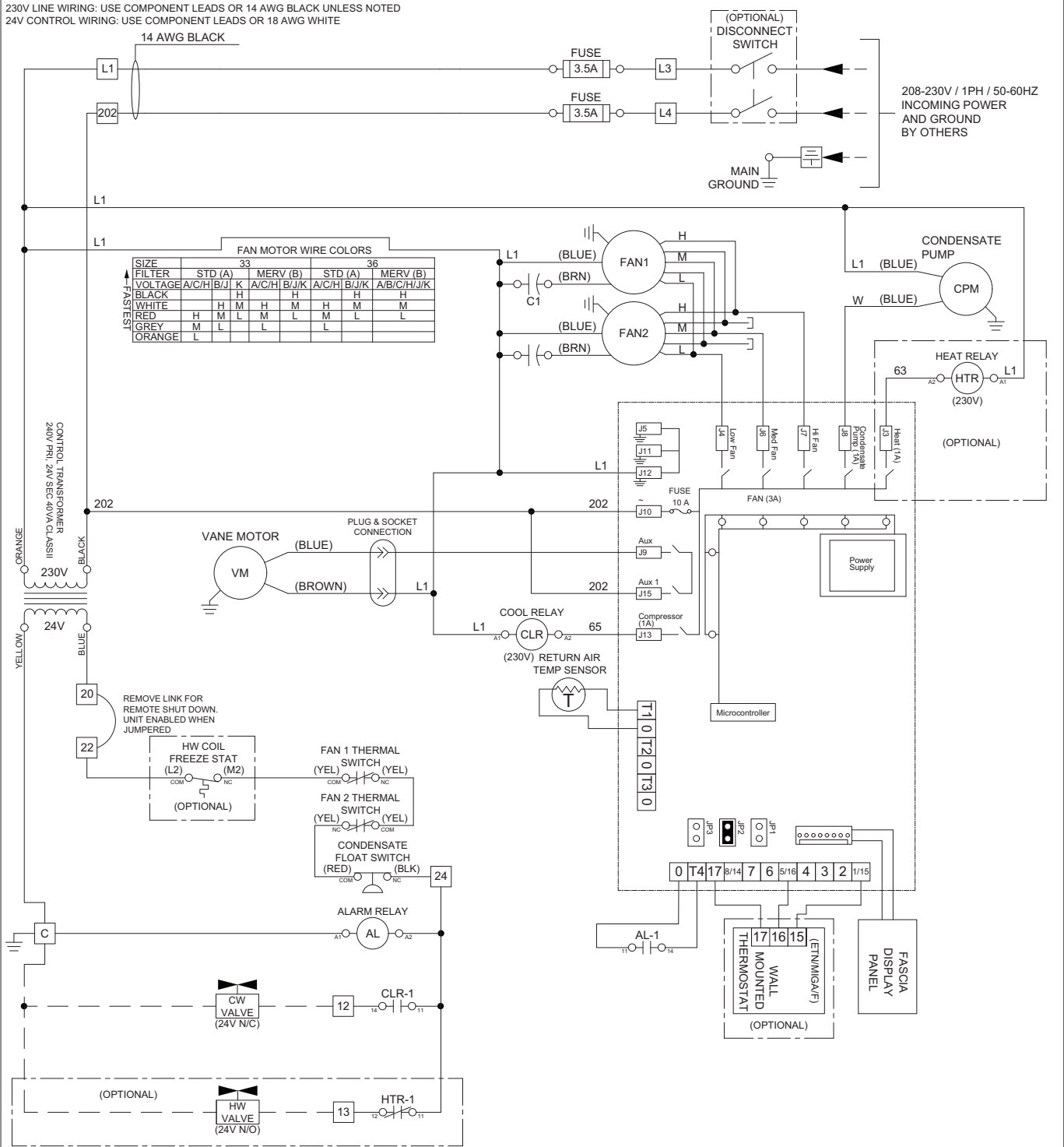

Fig. 26 — 42WKN Unit 2-Pipe Cooling Only or 4-Pipe System with Microprocessor Control Wiring Diagram, 208V, Sizes 33 and 36

230V LINE WIRING: USE COMPONENT LEADS OR 14 AWG BLACK UNLESS NOTED
 24V CONTROL WIRING: USE COMPONENT LEADS OR 18 AWG WHITE



<p>WARNING</p> <p>1) DISCONNECT POWER SUPPLY BEFORE MAKING CONNECTIONS TO PREVENT ELECTRICAL SHOCK AND EQUIPMENT DAMAGE. 2) ALL UNITS MUST BE WIRED STRICTLY IN ACCORDANCE WITH WIRING DIAGRAM FURNISHED WITH THE UNIT. ANY WIRING DIFFERENT FROM THE WIRING DIAGRAM COULD RESULT IN A HAZARD TO PERSONS AND PROPERTY. 3) ANY ORIGINAL FACTORY WIRING THAT REQUIRES REPLACEMENT MUST BE REPLACED WITH WIRING MATERIAL HAVING A TEMPERATURE RATING OF AT LEAST 105°C.</p>	<p>IMPORTANT</p> <p>INSTALLATION OF WIRING MUST CONFORM WITH LOCAL BUILDING CODES OR IN THE ABSENCE OF LOCAL CODES, OF THE NATIONAL ELECTRICAL CODE ANSI/NFPA 70 - LATEST EDITION. UNIT MUST BE ELECTRICALLY GROUNDED IN CONFORMANCE TO THIS CODE. IN CANADA, WIRING MUST COMPLY WITH CSA C22.1, PART 1, ELECTRICAL CODE.</p>	<p>WIRING LEGEND</p> <p>FACTORY INSTALLED ———</p> <p>FIELD INSTALLED - - - - -</p> <p>TERMINAL BLOCK </p> <p>COMPONENT TERMINAL </p> <p>CONNECTED PATH </p> <p>OPTIONAL COMPONENT </p> <p>PLUG AND SOCKET </p>	<p>CHILLED WATER 2 POSITION LARGE CASSETTE MICROPROCESSOR CONTROLS WITH OPTIONAL HOT WATER</p> <table border="1"> <tr> <td>WIRING DIAGRAM</td> <td>REV</td> </tr> <tr> <td>5H104891-1203</td> <td>I</td> </tr> </table>	WIRING DIAGRAM	REV	5H104891-1203	I
WIRING DIAGRAM	REV						
5H104891-1203	I						

Fig. 27 — 42WKN Unit 2-Pipe Cooling Only or 4-Pipe System with Microprocessor Control Wiring Diagram, 230V, Sizes 33 and 36

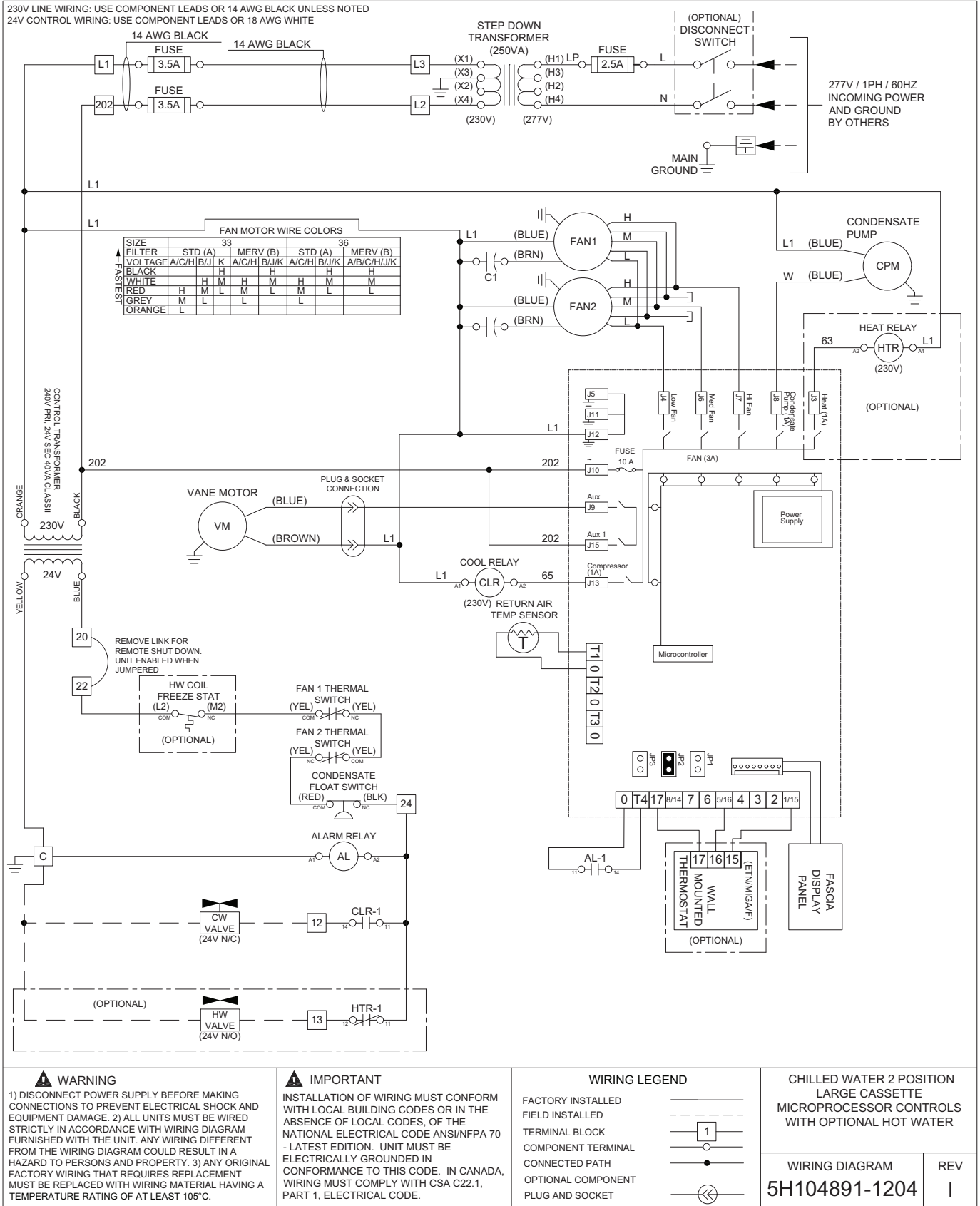
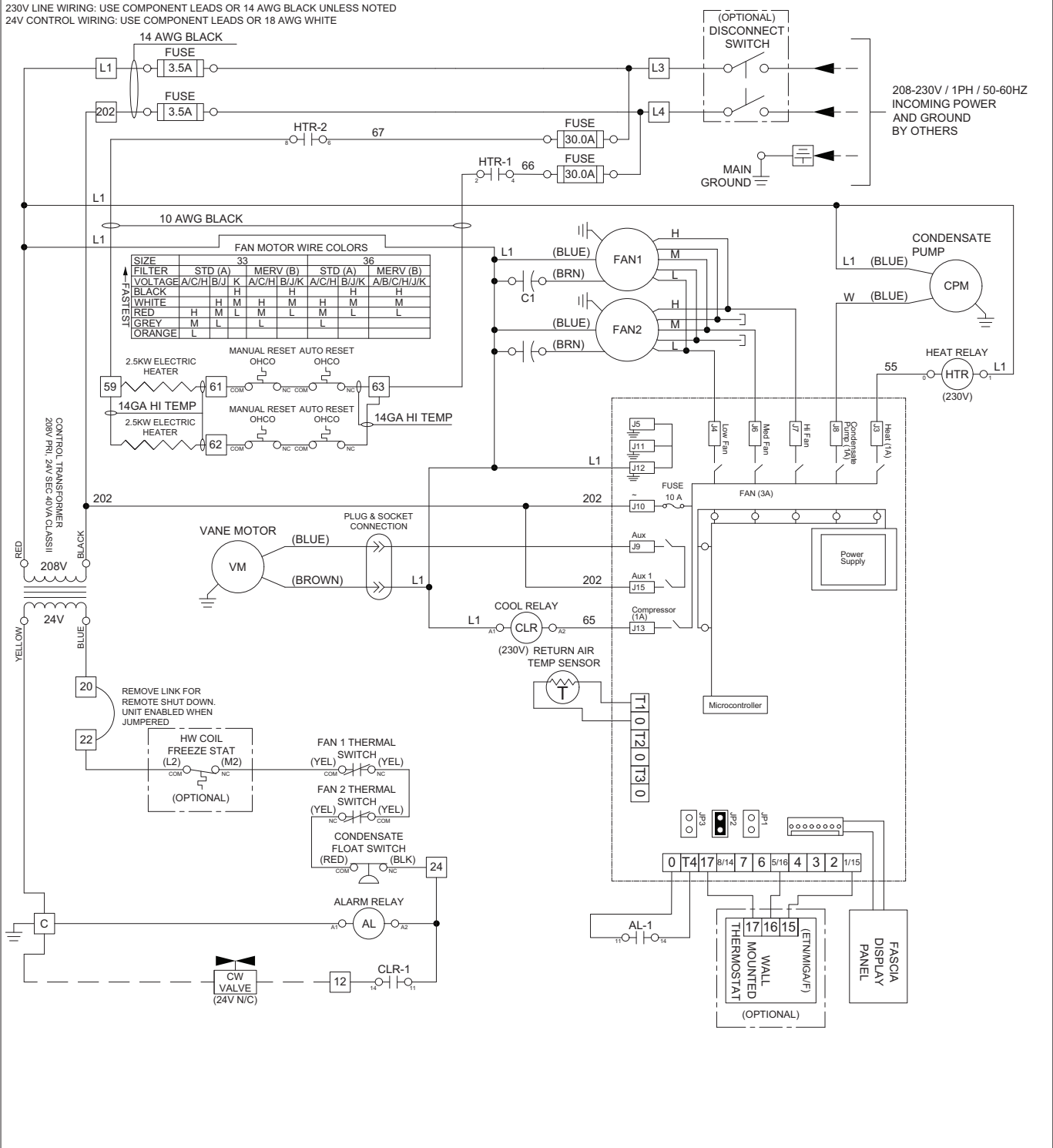

Fig. 28 — 42WKN Unit 2-Pipe Cooling Only or 4-Pipe System with Microprocessor Control Wiring Diagram, 277v, Sizes 33 and 36

230V LINE WIRING: USE COMPONENT LEADS OR 14 AWG BLACK UNLESS NOTED
 24V CONTROL WIRING: USE COMPONENT LEADS OR 18 AWG WHITE



<p>WARNING</p> <p>1) DISCONNECT POWER SUPPLY BEFORE MAKING CONNECTIONS TO PREVENT ELECTRICAL SHOCK AND EQUIPMENT DAMAGE. 2) ALL UNITS MUST BE WIRED STRICTLY IN ACCORDANCE WITH WIRING DIAGRAM FURNISHED WITH THE UNIT. ANY WIRING DIFFERENT FROM THE WIRING DIAGRAM COULD RESULT IN A HAZARD TO PERSONS AND PROPERTY. 3) ANY ORIGINAL FACTORY WIRING THAT REQUIRES REPLACEMENT MUST BE REPLACED WITH WIRING MATERIAL HAVING A TEMPERATURE RATING OF AT LEAST 105°C.</p>	<p>IMPORTANT</p> <p>INSTALLATION OF WIRING MUST CONFORM WITH LOCAL BUILDING CODES OR IN THE ABSENCE OF LOCAL CODES, OF THE NATIONAL ELECTRICAL CODE ANS/NFPA 70 - LATEST EDITION. UNIT MUST BE ELECTRICALLY GROUNDED IN CONFORMANCE TO THIS CODE. IN CANADA, WIRING MUST COMPLY WITH CSA C22.1, PART 1, ELECTRICAL CODE.</p>	<p>WIRING LEGEND</p> <p>FACTORY INSTALLED ———</p> <p>FIELD INSTALLED - - - - -</p> <p>TERMINAL BLOCK </p> <p>COMPONENT TERMINAL </p> <p>CONNECTED PATH </p> <p>OPTIONAL COMPONENT </p> <p>PLUG AND SOCKET </p>	<p>CHILLED WATER 2 POSITION LARGE CASSETTE MICROPROCESSOR CONTROLS WITH ELECTRIC HEAT</p> <table border="1"> <tr> <td>WIRING DIAGRAM</td> <td>REV</td> </tr> <tr> <td>5H104891-1212</td> <td>I</td> </tr> </table>	WIRING DIAGRAM	REV	5H104891-1212	I
WIRING DIAGRAM	REV						
5H104891-1212	I						

Fig. 29 — 42WKN Unit 2-Pipe Cooling Only with Electric Heat, Microprocessor Control Wiring Diagram, 208v, Sizes 33 and 36

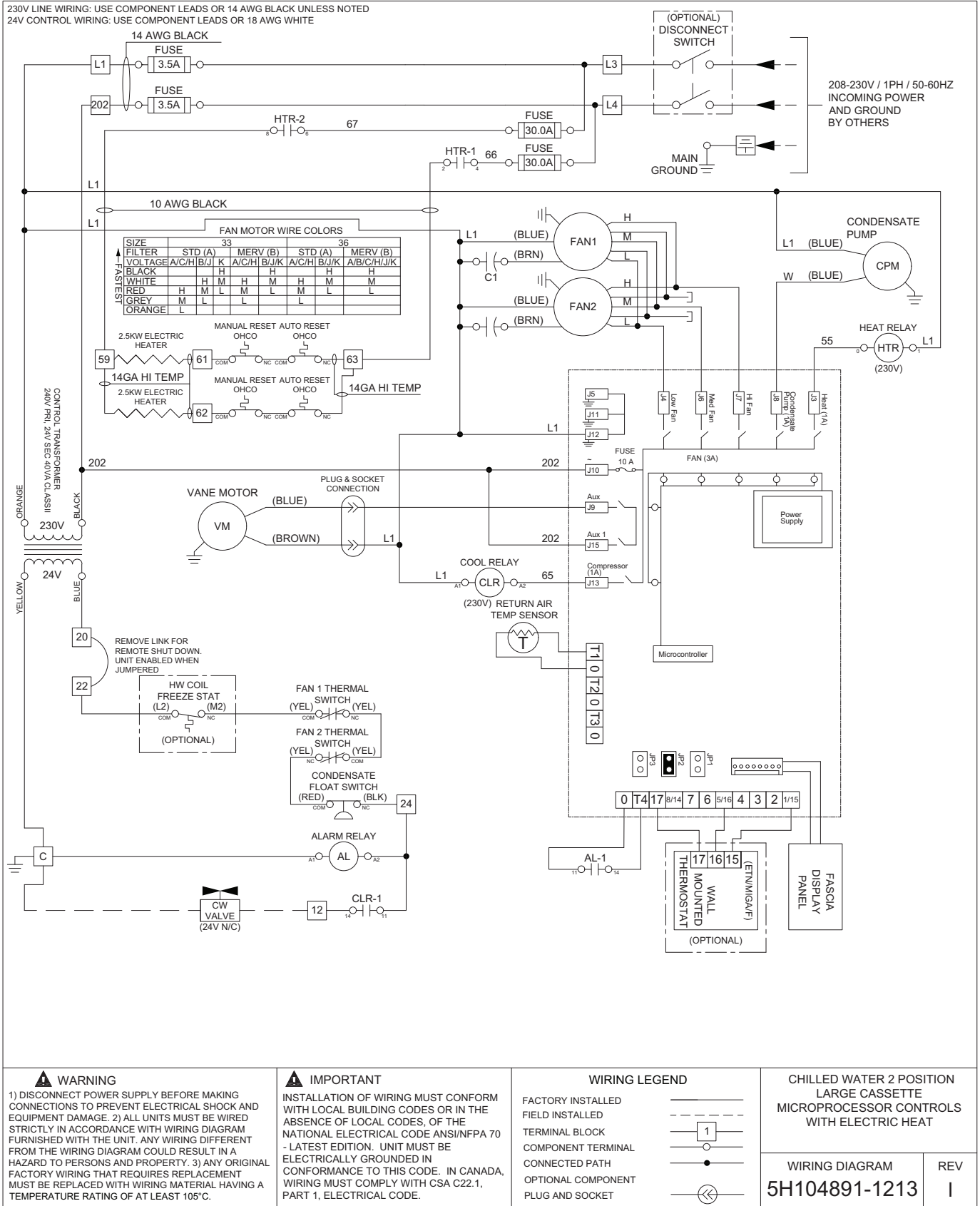
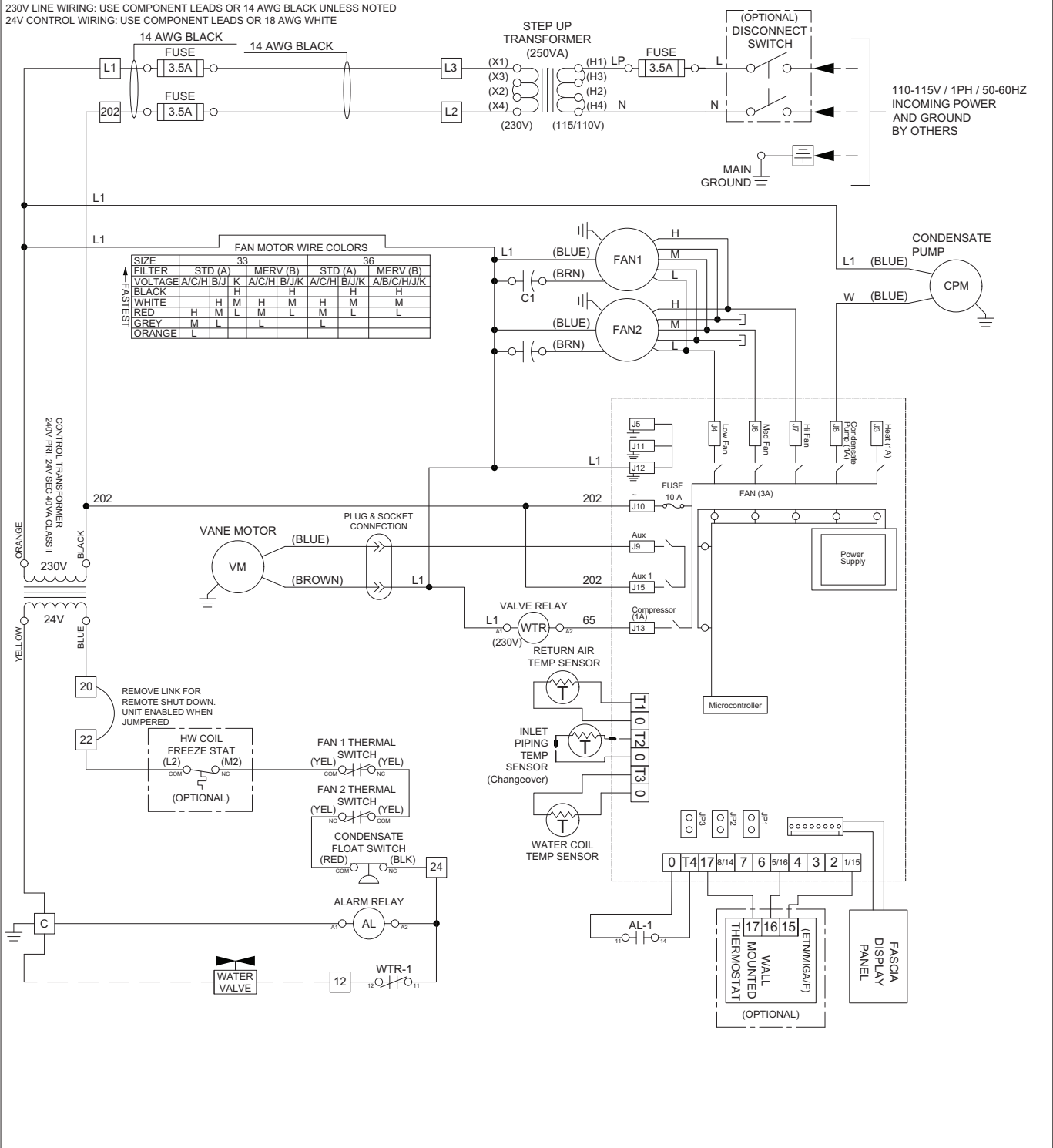

Fig. 30 — 42WKN Unit 2-Pipe Cooling Only with Electric Heat, Microprocessor Control Wiring Diagram, 230v, Sizes 33 and 36

230V LINE WIRING: USE COMPONENT LEADS OR 14 AWG BLACK UNLESS NOTED
 24V CONTROL WIRING: USE COMPONENT LEADS OR 18 AWG WHITE



<p>WARNING</p> <p>1) DISCONNECT POWER SUPPLY BEFORE MAKING CONNECTIONS TO PREVENT ELECTRICAL SHOCK AND EQUIPMENT DAMAGE. 2) ALL UNITS MUST BE WIRED STRICTLY IN ACCORDANCE WITH WIRING DIAGRAM FURNISHED WITH THE UNIT. ANY WIRING DIFFERENT FROM THE WIRING DIAGRAM COULD RESULT IN A HAZARD TO PERSONS AND PROPERTY. 3) ANY ORIGINAL FACTORY WIRING THAT REQUIRES REPLACEMENT MUST BE REPLACED WITH WIRING MATERIAL HAVING A TEMPERATURE RATING OF AT LEAST 105°C.</p>	<p>IMPORTANT</p> <p>INSTALLATION OF WIRING MUST CONFORM WITH LOCAL BUILDING CODES OR IN THE ABSENCE OF LOCAL CODES, OF THE NATIONAL ELECTRICAL CODE ANSI/NFPA 70 - LATEST EDITION. UNIT MUST BE ELECTRICALLY GROUNDED IN CONFORMANCE TO THIS CODE. IN CANADA, WIRING MUST COMPLY WITH CSA C22.1, PART 1, ELECTRICAL CODE.</p>	<p>WIRING LEGEND</p> <p>FACTORY INSTALLED ———</p> <p>FIELD INSTALLED - - - - -</p> <p>TERMINAL BLOCK </p> <p>COMPONENT TERMINAL </p> <p>CONNECTED PATH </p> <p>OPTIONAL COMPONENT </p> <p>PLUG AND SOCKET </p>	<p>CHILLED WATER 2 POSITION LARGE CASSETTE MICROPROCESSOR CONTROLS CHANGEOVER</p> <table border="1"> <tr> <td>WIRING DIAGRAM</td> <td>REV</td> </tr> <tr> <td>5H104891-1221</td> <td>I</td> </tr> </table>	WIRING DIAGRAM	REV	5H104891-1221	I
WIRING DIAGRAM	REV						
5H104891-1221	I						

Fig. 31 — 42WKN Unit 2-Pipe Heating/Cooling Changeover with Microprocessor Control Wiring Diagram, 115v, Sizes 33 and 36

230V LINE WIRING: USE COMPONENT LEADS OR 14 AWG BLACK UNLESS NOTED
 24V CONTROL WIRING: USE COMPONENT LEADS OR 18 AWG WHITE

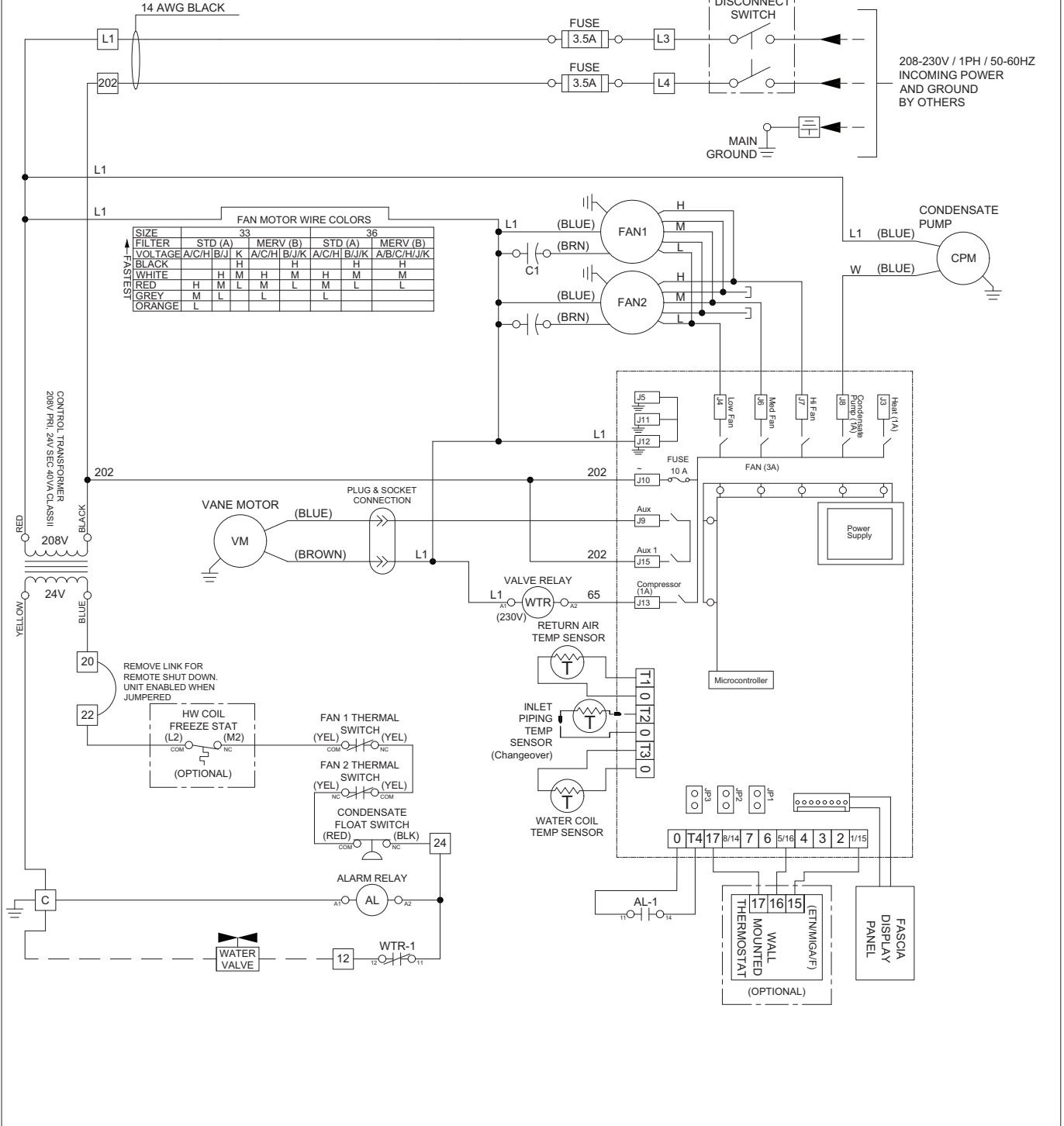

<p>WARNING</p> <p>1) DISCONNECT POWER SUPPLY BEFORE MAKING CONNECTIONS TO PREVENT ELECTRICAL SHOCK AND EQUIPMENT DAMAGE. 2) ALL UNITS MUST BE WIRED STRICTLY IN ACCORDANCE WITH WIRING DIAGRAM FURNISHED WITH THE UNIT. ANY WIRING DIFFERENT FROM THE WIRING DIAGRAM COULD RESULT IN A HAZARD TO PERSONS AND PROPERTY. 3) ANY ORIGINAL FACTORY WIRING THAT REQUIRES REPLACEMENT MUST BE REPLACED WITH WIRING MATERIAL HAVING A TEMPERATURE RATING OF AT LEAST 105°C.</p>	<p>IMPORTANT</p> <p>INSTALLATION OF WIRING MUST CONFORM WITH LOCAL BUILDING CODES OR IN THE ABSENCE OF LOCAL CODES, OF THE NATIONAL ELECTRICAL CODE ANSI/NFPA 70 - LATEST EDITION. UNIT MUST BE ELECTRICALLY GROUNDED IN CONFORMANCE TO THIS CODE. IN CANADA, WIRING MUST COMPLY WITH CSA C22.1, PART 1, ELECTRICAL CODE.</p>	<p>WIRING LEGEND</p> <p>FACTORY INSTALLED ———</p> <p>FIELD INSTALLED - - - - -</p> <p>TERMINAL BLOCK </p> <p>COMPONENT TERMINAL </p> <p>CONNECTED PATH </p> <p>OPTIONAL COMPONENT </p> <p>PLUG AND SOCKET </p>	<p>CHILLED WATER 2 POSITION LARGE CASSETTE MICROPROCESSOR CONTROLS CHANGEOVER</p> <table border="1"> <tr> <td>WIRING DIAGRAM</td> <td>REV</td> </tr> <tr> <td>5H104891-1222</td> <td>I</td> </tr> </table>	WIRING DIAGRAM	REV	5H104891-1222	I
WIRING DIAGRAM	REV						
5H104891-1222	I						

Fig. 32 — 42WKN Unit 2-Pipe Heating/Cooling Changeover with Microprocessor Control Wiring Diagram, 208v, Sizes 33 and 36

230V LINE WIRING: USE COMPONENT LEADS OR 14 AWG BLACK UNLESS NOTED
 24V CONTROL WIRING: USE COMPONENT LEADS OR 18 AWG WHITE

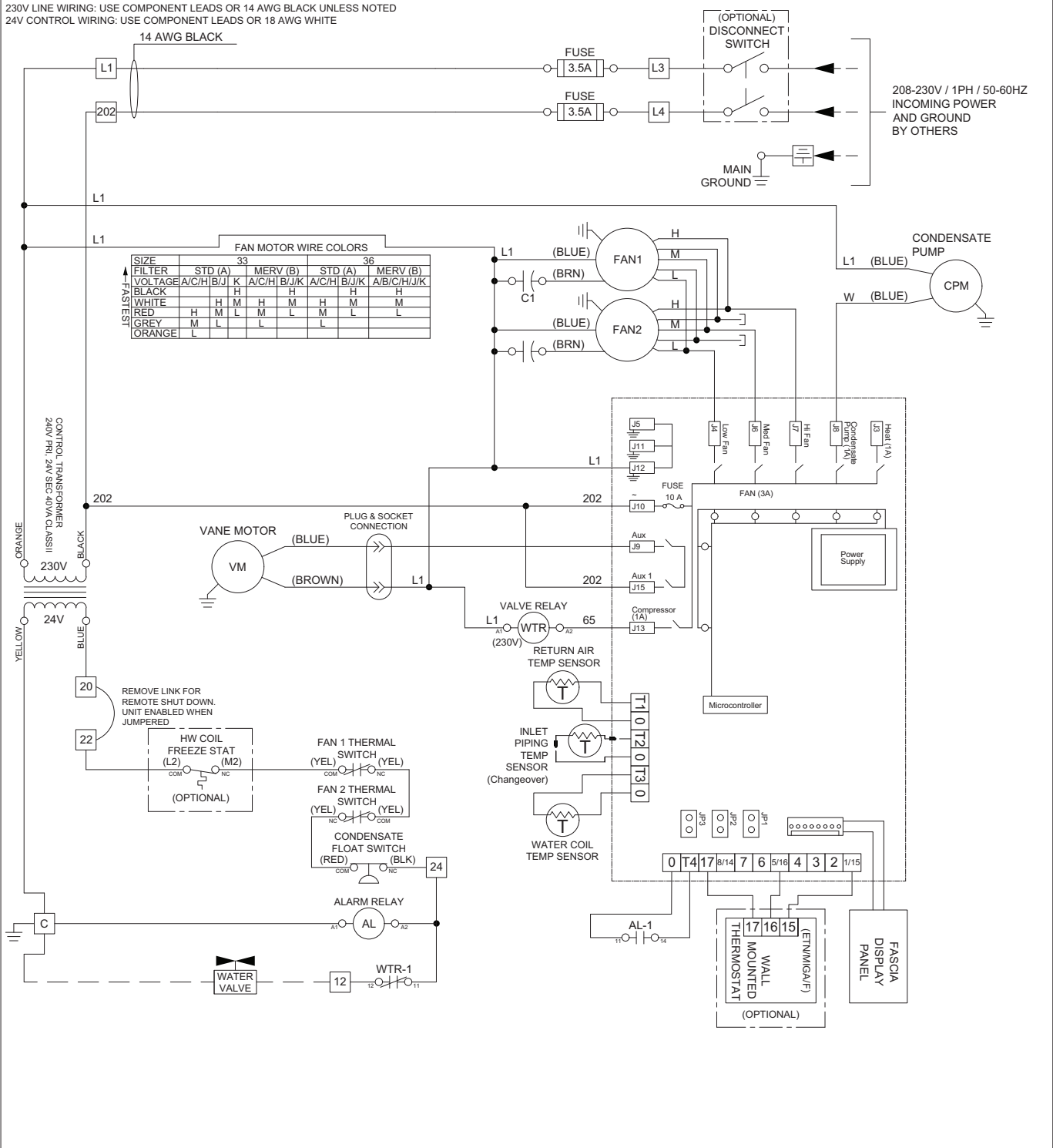

<p>WARNING</p> <p>1) DISCONNECT POWER SUPPLY BEFORE MAKING CONNECTIONS TO PREVENT ELECTRICAL SHOCK AND EQUIPMENT DAMAGE. 2) ALL UNITS MUST BE WIRED STRICTLY IN ACCORDANCE WITH WIRING DIAGRAM FURNISHED WITH THE UNIT. ANY WIRING DIFFERENT FROM THE WIRING DIAGRAM COULD RESULT IN A HAZARD TO PERSONS AND PROPERTY. 3) ANY ORIGINAL FACTORY WIRING THAT REQUIRES REPLACEMENT MUST BE REPLACED WITH WIRING MATERIAL HAVING A TEMPERATURE RATING OF AT LEAST 105°C.</p>	<p>IMPORTANT</p> <p>INSTALLATION OF WIRING MUST CONFORM WITH LOCAL BUILDING CODES OR IN THE ABSENCE OF LOCAL CODES, OF THE NATIONAL ELECTRICAL CODE ANSI/NFPA 70 - LATEST EDITION. UNIT MUST BE ELECTRICALLY GROUNDED IN CONFORMANCE TO THIS CODE. IN CANADA, WIRING MUST COMPLY WITH CSA C22.1, PART 1, ELECTRICAL CODE.</p>	<p>WIRING LEGEND</p> <p>FACTORY INSTALLED ———</p> <p>FIELD INSTALLED - - - - -</p> <p>TERMINAL BLOCK </p> <p>COMPONENT TERMINAL </p> <p>CONNECTED PATH </p> <p>OPTIONAL COMPONENT </p> <p>PLUG AND SOCKET </p>	<p>CHILLED WATER 2 POSITION LARGE CASSETTE MICROPROCESSOR CONTROLS CHANGEOVER</p> <table border="1"> <tr> <td>WIRING DIAGRAM</td> <td>REV</td> </tr> <tr> <td>5H104891-1223</td> <td>I</td> </tr> </table>	WIRING DIAGRAM	REV	5H104891-1223	I
WIRING DIAGRAM	REV						
5H104891-1223	I						

Fig. 33 — 42WKN Unit 2-Pipe Heating/Cooling Changeover with Microprocessor Control Wiring Diagram, 230v, Sizes 33 and 36

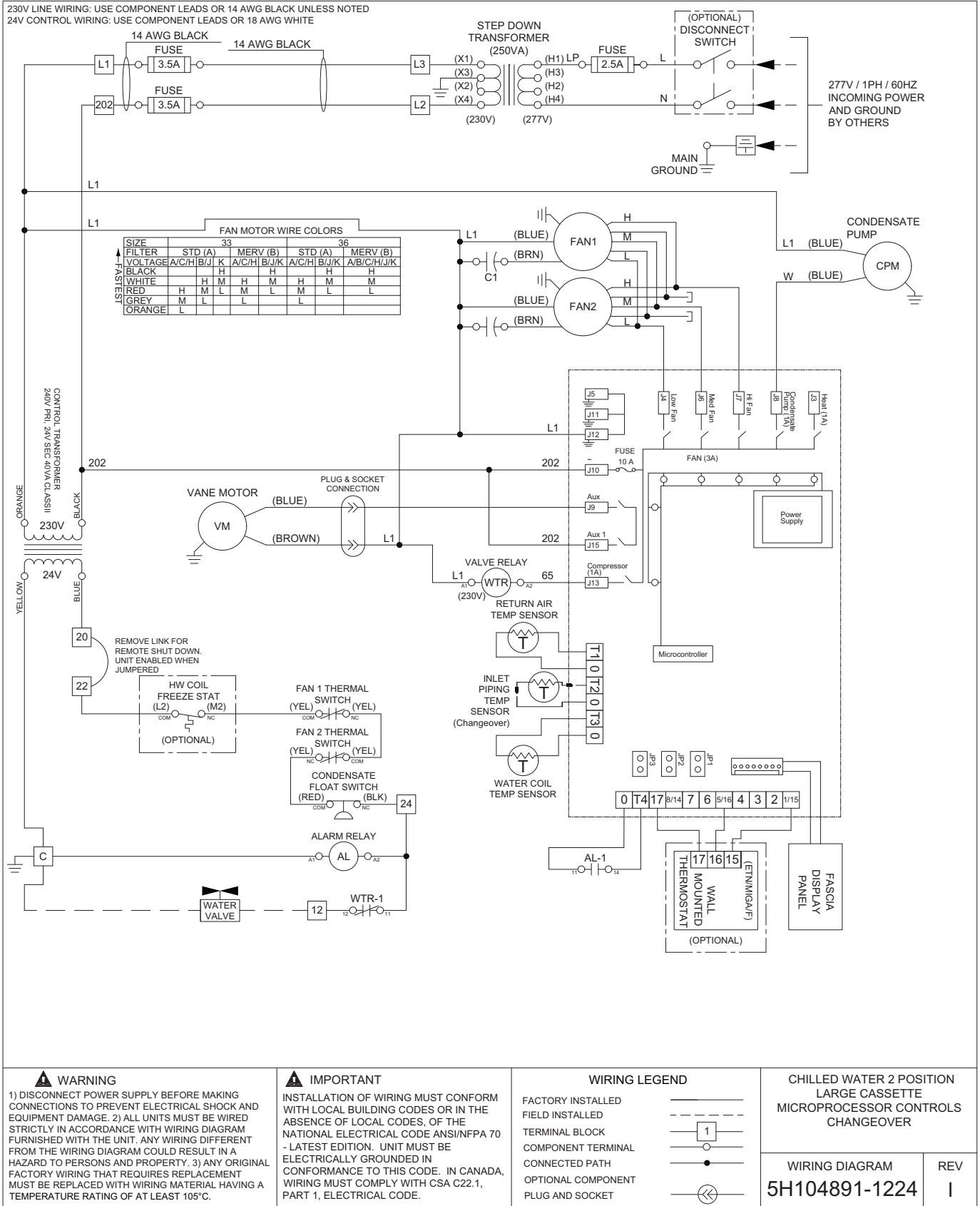
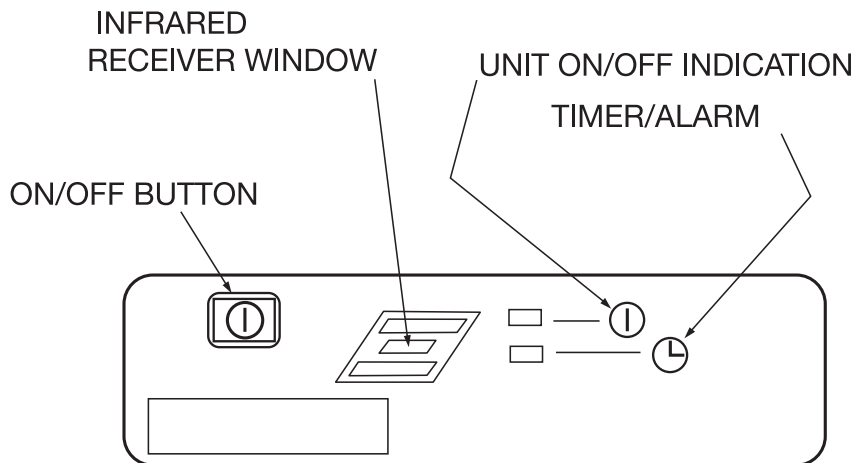

Fig. 34 — 42WKN Unit 2-Pipe Heating/Cooling Changeover with Microprocessor Control Wiring Diagram, 277v, Sizes 33 and 36



Fig. 35 — Infrared Transmitter



LED NAME	LED STATE	SYSTEM STATE
On	ON	ON
On	OFF	OFF
Timer	Blinking	<ul style="list-style-type: none"> • Timer ON • Power returned after break while Timer was active
Timer and On	Blinking synchronous	<ul style="list-style-type: none"> • Fault F1 indication — error with unit mounted return air sensor • Fault on T4,0 input (input was opened for more than 10 seconds) <ul style="list-style-type: none"> — Condensate high level — Freeze stat alarm

Fig. 36 — Infrared Receiver

PRE-INSTALLATION

Unpack Unit

Remove the banding straps and lift the cardboard lid. Remove the fascia, packed in bubble wrap, and polystyrene packing pieces to expose the unit.

When removing the unit chassis from the box, the four corner brackets should be utilized for lifting. In order to protect the fascia from dirt and damage, it should be returned to the box until it is ready to be installed.

Blank Off Pieces

When branch ducting is to be used, polystyrene pieces for blanking off fascia openings are included with the fascia packing. Up to two opposing sides may be blanked off. See "Duct Collars" in Installation section, page 40.

Positioning

⚠ DANGER

Appliances must not be installed where they may be exposed to potentially explosive or flammable atmosphere.

The unit installation position should be selected with the following points in mind:

1. The appliance must be installed on a structure that is suitable to support the total weight of the appliance, piping, and condensate.
2. Piping, electrical panel and condensate pump access panel should be readily accessible for maintenance purposes. A 2-ft clearance is recommended around the electrical panel and condensate pump access panel.
3. The unit should not be positioned less than 5 ft from a wall or similar obstruction, or in a position where the discharge air could blow directly on to the thermostat. A 5-ft clearance is required below the unit for service access.
4. The unit should not be positioned directly above any obstructions.
5. The unit must be installed square and level.
6. The condensate drain should have sufficient downward slope (1 inch in 100-in.) in any horizontal run between unit and drain. Maximum condensate pump lift is 30 inches.
7. There should be sufficient room above the false ceiling for installing the unit. Minimum distance as shown in Fig. 37.
8. In case of high humidity, clogged or damaged condensate piping, incorrect installation or faulty condensate pump, water may drip from the unit. Do not install the appliance where dripping water can cause damage.

Ceiling Opening Sizes

An opening in the false ceiling will then have to be cut to the size shown in Table 2.

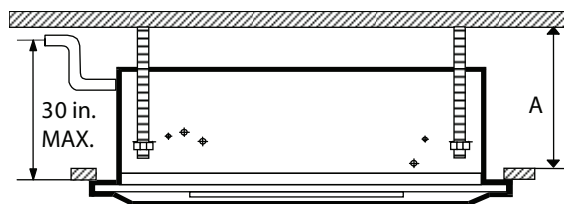

42WKN UNIT SIZE	DIMENSION A (in.)
08,12	12 ³ / ₄
18,20	11 ¹ / ₂
33,36	13 ¹ / ₂

Fig. 37 — Minimum Distance to Ceiling

Table 2 — Ceiling Opening Dimensions

42WKN UNIT SIZE	DIMENSIONS (in.)
08,12	23-in. x 23-in.
18,20	34-in. x 34-in.
33,36	46-in. x 34-in.

A cardboard template for ceiling cutout and rod positions is included with the unit.

Positioning the Electro-Mechanical Thermostat

In addition to positioning the unit correctly, it is very important to locate the wall-mounted thermostat in the optimum position to ensure good temperature control. Therefore, the installation should be selected with the following points in mind:

1. Position the thermostat approximately 48-in. above floor level.
2. Do not position thermostat where it can be directly affected by the unit's discharge airstream.
3. Avoid external walls and drafts from windows and doors.
4. Avoid positioning near shelves and curtains as these restrict air movement.
5. Avoid heat sources e.g., direct sunlight, heaters, dimmer switches and other electrical devices.

INSTALLATION

IMPORTANT: Make sure the ceiling grid is supported separately from the appliance. The ceiling must not be supported by any part of the appliance, fascia or any associated wiring or pipe work.

Hanger Bolts

The hanger bolts can now be installed at the centers shown in Fig. 38. Use ³/₈-in. all thread rod.

Check the strength of the unit mounting hanger bolts. Refer to Table 1 for unit weights.

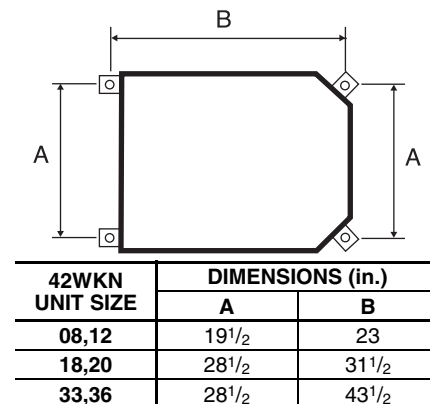

Fig. 38 — Hanger Bolt Mounting Dimensions

Installation Guide

An installation guide is included in the Carrier Owner Information packet provided with the unit. Prepare the installation guide by folding the flat metal piece, by hand, along the perforations as shown in Fig. 39.

INSTALLATION GUIDE SETUP

The unit can now be lifted onto the hanging rods and leveled at the correct distance from the ceiling with the aid of the installation guide.

1. Hold the tab on the installation guide against the bottom of the cassette case with the guide pointing away from the cassette. See Fig. 40. Adjust the height of the cassette until the guide is level with the bottom of the false ceiling.

- Secure the unit in position with locknuts and washers on both sides of the unit bracket. Ensure the threaded rod does not protrude more than 2-in. below the mounting bracket as shown in Fig. 41.

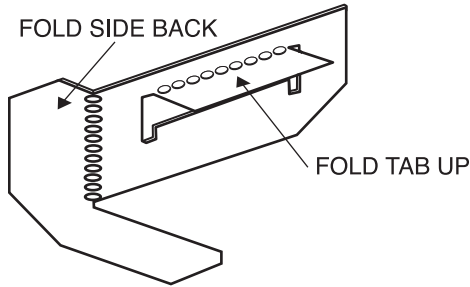

Fig. 39 — Setting Up Installation Guide

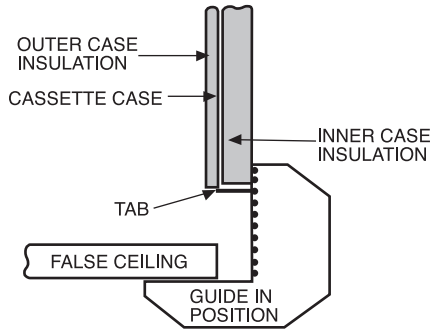

Fig. 40 — Positioning Installation Guide

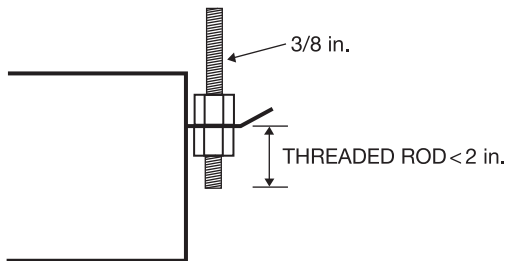

Fig. 41 — Threaded Rod Dimension

Condensate Piping

The unit is supplied with a 3/8-in. ID flexible hose for connection to copper or plastic drain piping.

When installing the unit, the following points should be remembered:

- Maximum pump lift is 30 inches.
- The highest point in the condensate piping should be as close to the unit as possible. See Fig. 42.
- Condensate piping should slope downwards in the direction of water flow with a minimum gradient of 1 inch in 100 inches. There must not be any uphill gradients other than in the first 30-in. of piping from the unit.
- When multiple units are connected to a common condensate drain, ensure the drain is large enough to cope with the volume of condensate from all units. It is also recommended to have an air vent in the condensate piping to prevent any air locks.
- Condensate piping must not be installed where it may be exposed to freezing temperatures.

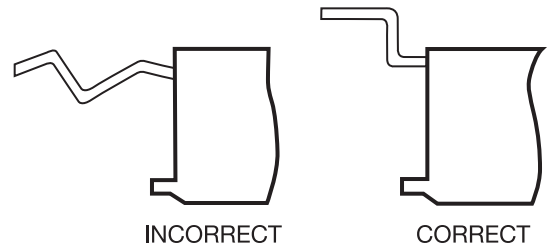

Fig. 42 — Condensate Piping

Duct Collars

Up to 2 branch ducts can be attached per unit. Branch duct and fresh air duct collars can be attached to the unit chassis by following the steps below:

- Refer to Fig. 2-4 to become familiarized with knockout hole locations.
- The insulation is pre-cut to aid location and removal of the relevant section. Rub hand across surface of insulation to reveal exact location of knockout.
- Remove the metal knockout from the chassis.
- Attach the duct collar to the chassis using self-tapping screws.
- Replace washable filter with the pleated filter provided with fresh air duct collar kit.

NOTE: See Fig. 2-4 for branch duct and fresh air duct locations and dimensions.

Piping Installation

- Branch piping to and from the unit should include swing joints to allow for expansion and contraction of the piping without placing a strain on the unit coil.
- Install pipe unions and shutoff valves in lines to and from each coil to allow maintenance or replacement of unit without shutting down and draining entire system. See Fig. 43.
- Include a circuit setter in return line for water flow regulation.
- A drain valve (hose bib) should also be provided for each coil line to allow removal of water from the coil if located in an area subject to freezing.
- It is advisable to use a pipe line strainer before each coil.
- Provide adequate pipe hangers, supports, or anchors to secure the piping system independently of the unit.
- On 2-pipe systems with microprocessor controls, install the factory-provided Changeover Sensor on the main supply water line upstream from the unit where water maintains flow. This ensures accurate readings of water temperature. Wire extension and a plug are included.

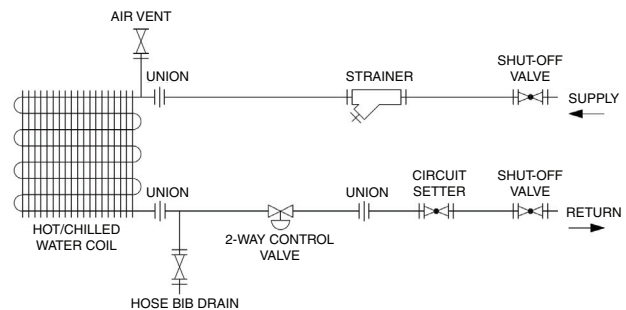

Fig. 43 — Installing Piping

Piping Insulation

Chilled water and condensate pipes should be insulated right up to the unit chassis to prevent condensation, which can damage the ceiling and objects located below the piping. Chilled water valves must also be insulated to prevent sweating.

Wiring

⚠ WARNING

Disconnect power supply before making wiring connections to prevent electrical shock and equipment damage. All appliances must be wired strictly in accordance with the wiring diagram furnished with the appliance. Any wiring different from the wiring diagram could result in a hazard to persons and property.

⚠ CAUTION

Any original factory wiring that requires replacement must be replaced with wiring material having a temperature rating of at least 105°C. Ensure supply voltage to the appliance, as indicated on the serial plate, is not more than 5% over rated voltage or less than 5% under the rated voltage. Failure to follow these recommendations may result in equipment damage.

Installation of wiring must conform with local building codes, or in the absence of local codes, with the National Electric Code ANSI/NFPA (American National Standards Institute/National Fire Protection Association) 70 - Latest Edition. Unit must be electrically grounded in conformance to this code. In Canada, wiring must comply with CSA (Canadian Standards Association) C22.1, Electrical Code.

Electric wiring must be sized to carry the full load amp draw of the motor, starter and any controls that are used with the unit. See Table 3 for electrical data.

This equipment in its standard form is designed for an electrical supply of 208/230-1-60. When connection to a 115-1-60 supply is necessary, a factory-mounted step-up transformer must be fitted to the unit. Any damage to or failure of units caused by incorrect wiring of the units is not covered by warranty.

Once the pipe work is complete, the electrical supply can be connected by routing the cable through the appropriate casing hole and connecting the supply and ground cables to the unit's power terminals.

NOTE: A plastic sleeve is provided inside the control panel. Low voltage control wiring must run through the plastic sleeve on the inside of the control panel.

Table 3 — Electric Data for All Voltages and for Units With or Without Electric Heat

42WKN NOMINAL CAPACITY (DIGIT 6, 7)	SUPPLY VOLTAGE (DIGIT 8)	PERFORMANCE (WITH ELECTRIC HEAT)			PERFORMANCE (NO ELECTRIC HEAT)		
		FLA	MCA	Recommended Fuse Size	FLA	MCA	Recommended Fuse Size
08 and 12 Small Chassis	A: 115/60/1	-	-	-	0.70	0.88	15
	J: 110/50/1						
	B: 208/60/1	6.25	7.81	15	0.35	0.44	15
	C: 230/60/1	6.87	8.59	15			
	K: 220/50/1	6.59	8.24	15			
H: 277/60/1	-	-	-	0.29	0.36	15	
18 and 20 Medium Chassis	A: 115/60/1	-	-	-	1.10	1.38	15
	J: 110/50/1						
	B: 208/60/1	12.35	15.44	20	0.55	0.69	15
	C: 230/60/1	13.59	16.99	20			
	K: 220/50/1	13.03	16.29	20			
H: 277/60/1	-	-	-	0.46	0.58	15	
30 and 36 Large Chassis	A: 115/60/1	-	-	-	1.92	2.40	15
	J: 110/50/1						
	B: 208/60/1	20.68	25.85	30	0.96	1.20	15
	C: 230/60/1	22.76	28.45	30			
	K: 220/50/1	21.81	27.26	30			
H: 277/60/1	-	-	-	0.80	1.00	15	

Terminal Strip Connections

The terminal strip connections are designed to clamp down on the incoming building power and thermostat wiring connections. To properly connect the wires to the terminal strip:

1. Push a small flat head screwdriver into the square hole on the terminal. Press firmly until the screwdriver hits the back stop and opens the terminal. See Fig. 44.
2. Remove approximately $\frac{3}{8}$ -in. of insulation from the end of the wire and push the stripped wire into the oval hole in the terminal.
3. Remove the screwdriver. Pull on the wire to make sure that it is securely clamped in the terminal.
4. Make sure that the terminal clamp is in contact with bare wire (insulation removed).



Fig. 44 — Terminal Strip

Refer to Fig. 45-53 for typical 42WKN unit wiring diagrams.

230V LINE WIRING: USE COMPONENT LEADS OR 18 AWG BROWN UNLESS NOTED
 24V CONTROL WIRING: USE COMPONENT LEADS OR 18 AWG WHITE

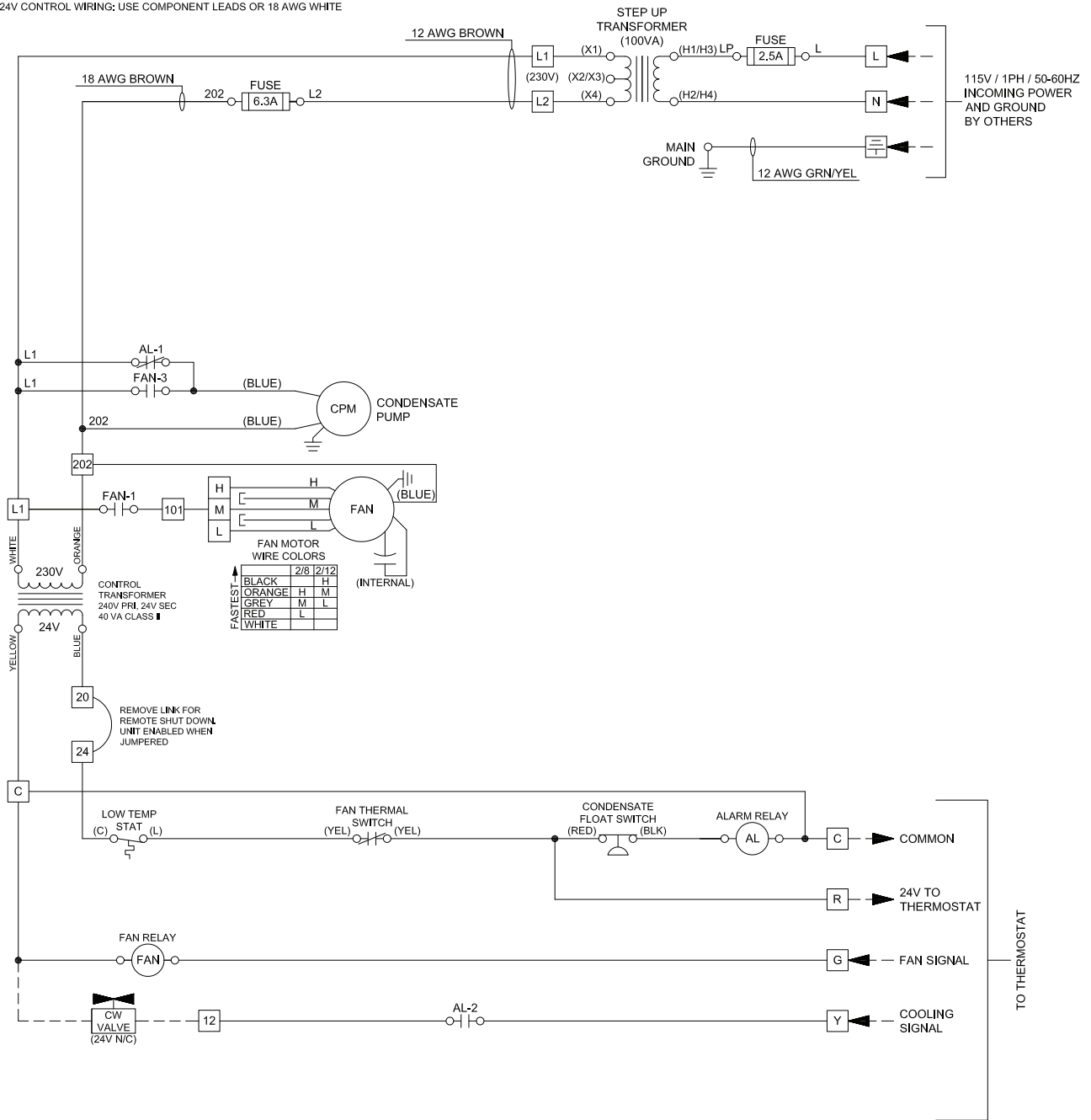

LEGEND

- AL** — Alarm Relay
- AWG** — American Wire Gage
- CPM** — Condensate Pump
- CW** — Chilled Water
- Factory-Installed
- - - Field-Installed
- 1** Terminal Block
- Component Terminal
- Connected Path

NOTE: Fan is wired to medium speed as a default. To change the default fan speed, adjust wiring in the field. Factory-provided electro-mechanical thermostats are for single speed fan operation only.

Fig. 45 — 42WKN Unit 2-Pipe Cooling or Heating Only with Electro-Mechanical Control Wiring Diagram, Sizes 08 and 12

230V LINE WIRING: USE COMPONENT LEADS OR 18 AWG BROWN UNLESS NOTED
 24V CONTROL WIRING: USE COMPONENT LEADS OR 18 AWG WHITE

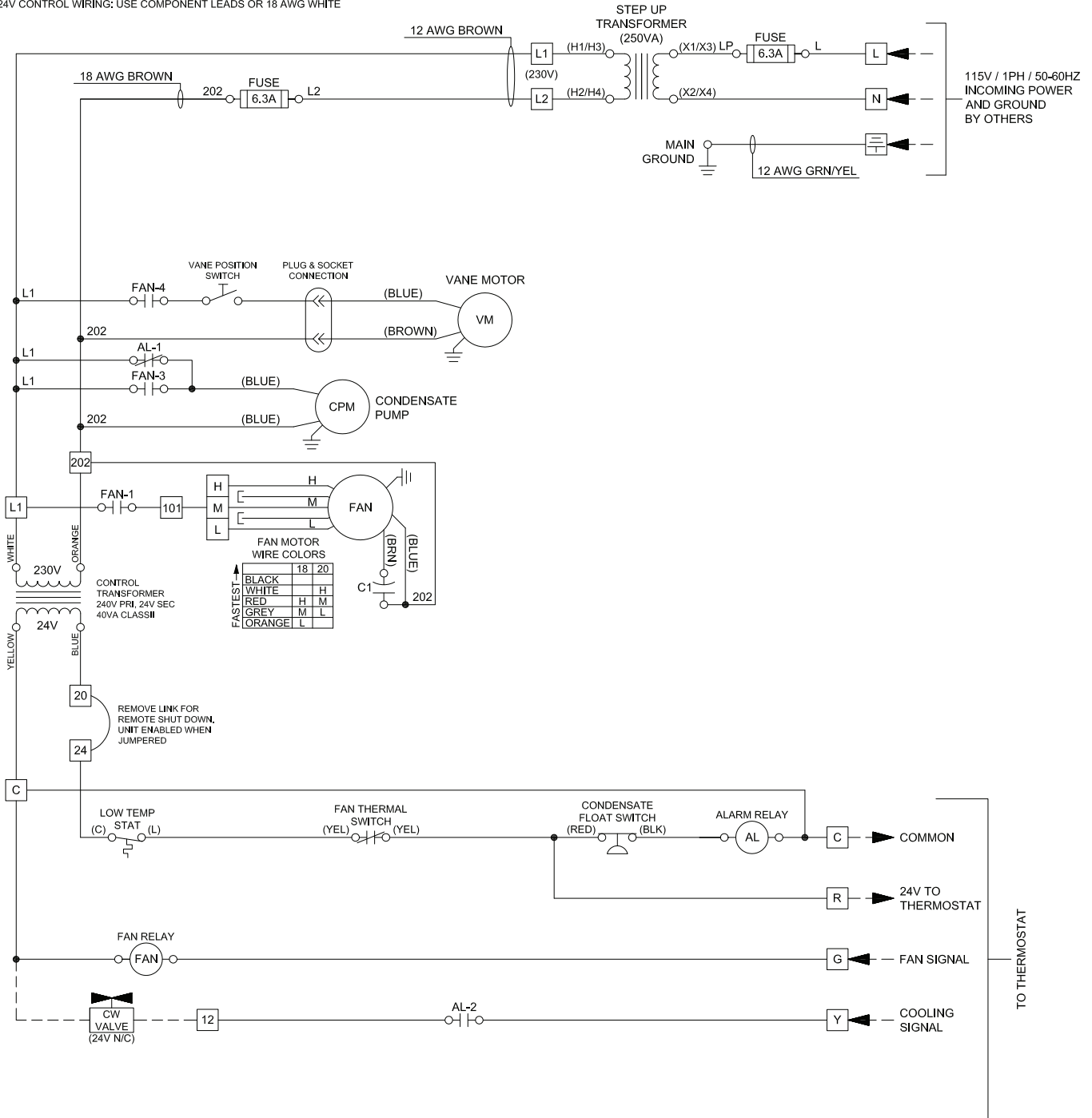

LEGEND

- AL** — Alarm Relay
- AWG** — American Wire Gage
- CPM** — Condensate Pump
- CW** — Chilled Water
- VM** — Vane Motor
- Factory-Installed
- - - - - Field-Installed
- [] Terminal Block
- Component Terminal
- Connected Path

NOTE: Fan is wired to medium speed as a default. To change the default fan speed, adjust wiring in the field. Factory-provided electro-mechanical thermostats are for single speed fan operation only.

Fig. 46 — 42WKN Unit 2-Pipe Cooling or Heating Only with Electro-Mechanical Control Wiring Diagram, Sizes 18 and 20

230V LINE WIRING: USE COMPONENT LEADS OR 18 AWG BROWN UNLESS NOTED
 24V CONTROL WIRING: USE COMPONENT LEADS OR 18 AWG WHITE

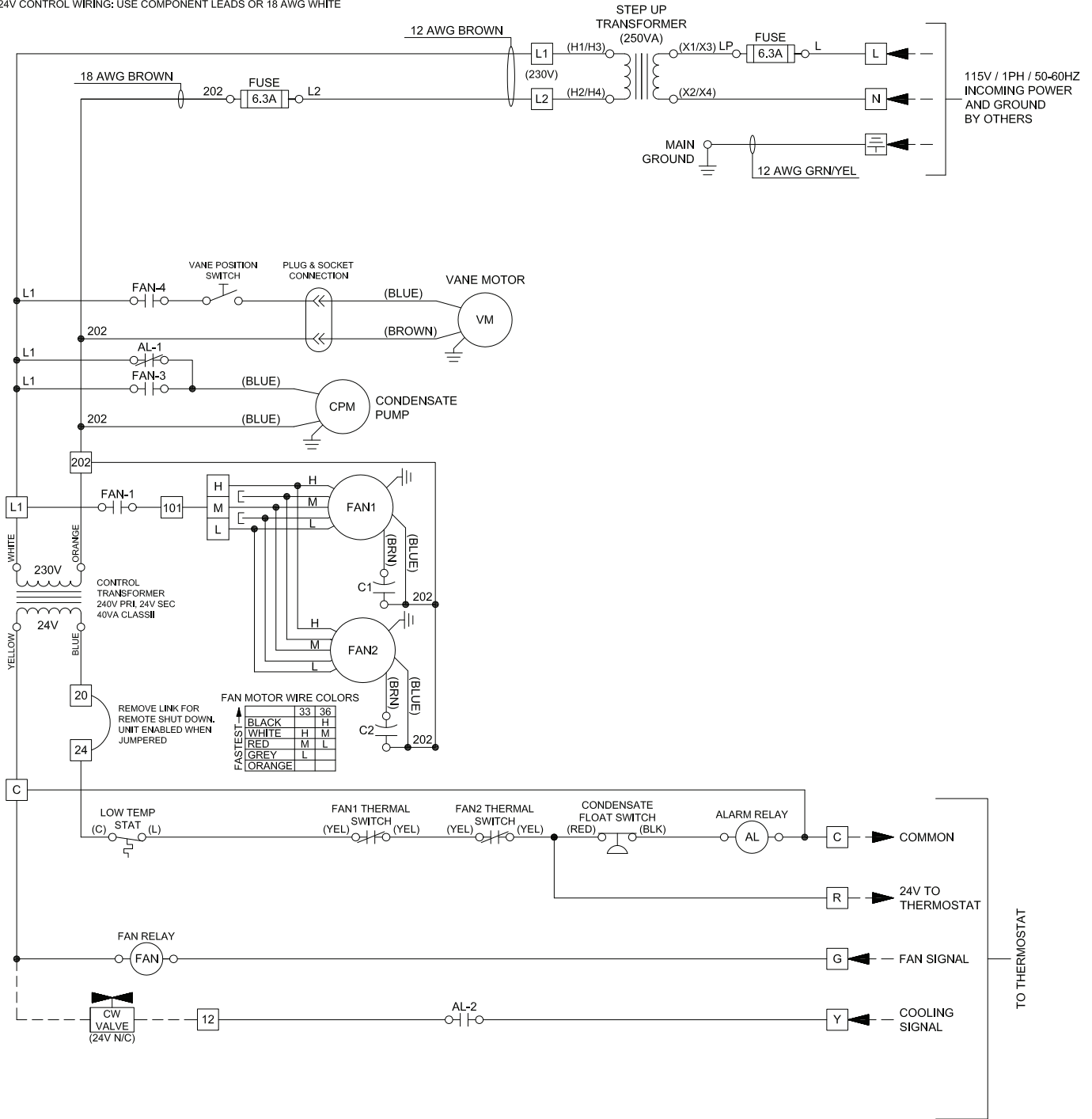

- LEGEND**
- AL** — Alarm Relay
 - AWG** — American Wire Gage
 - CPM** — Condensate Pump
 - CW** — Chilled Water
 - VM** — Vane Motor
 - Factory-Installed
 - - - - - Field-Installed
 - [] Terminal Block
 - Component Terminal
 - Connected Path

NOTE: Fan is wired to medium speed as a default. To change the default fan speed, adjust wiring in the field. Factory-provided electro-mechanical thermostats are for single speed fan operation only.

Fig. 47 — 42WKN Unit 2-Pipe Cooling or Heating Only with Electro-Mechanical Control Wiring Diagram, Sizes 33 and 36

230V LINE WIRING: USE COMPONENT LEADS OR 18 AWG BROWN UNLESS NOTED
 24V CONTROL WIRING: USE COMPONENT LEADS OR 18 AWG WHITE

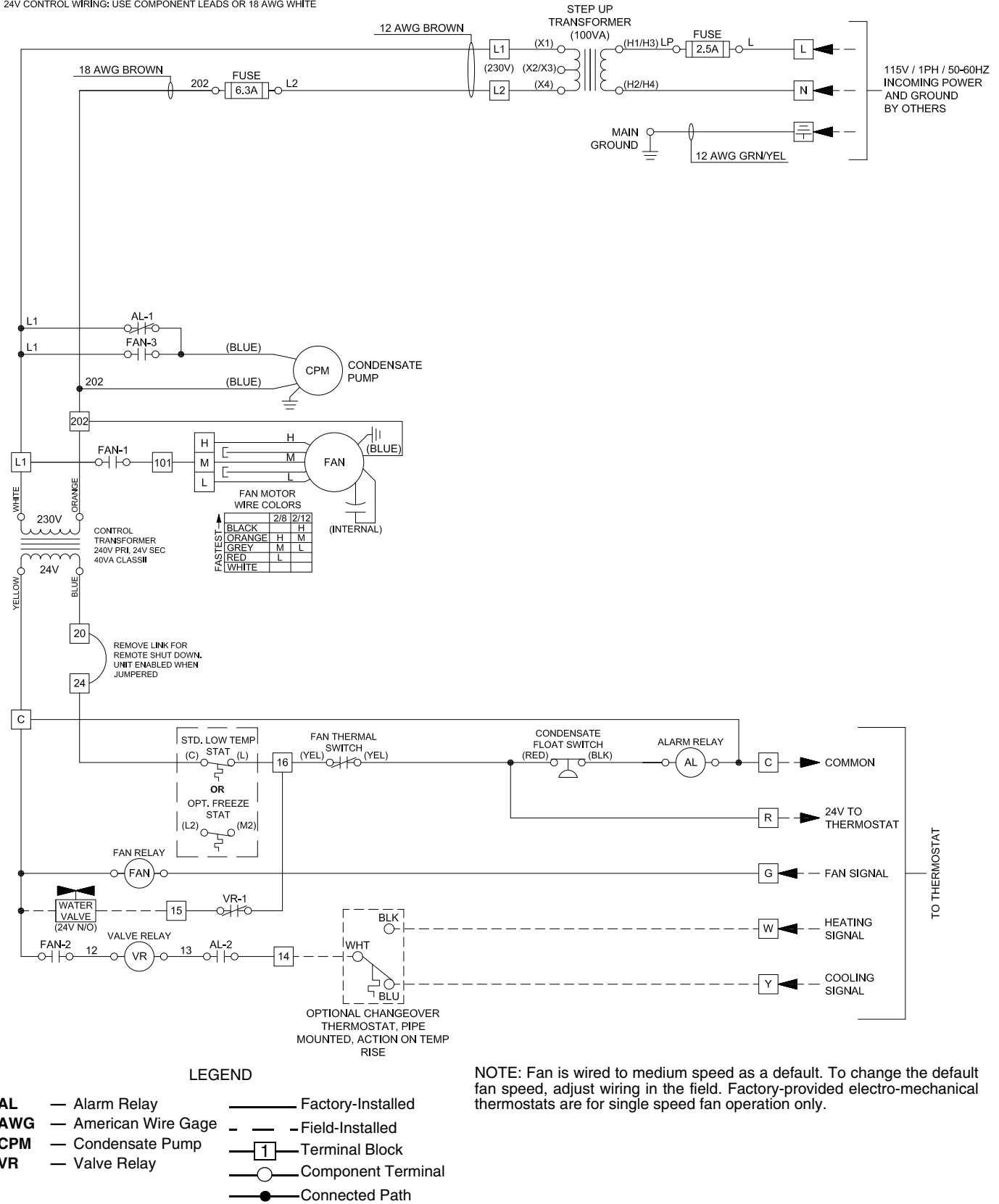

Fig. 48 — 42WKN Unit 2-Pipe System with Heating/Cooling Changeover, Aquastat, and Electro-Mechanical Control Wiring Diagram, Sizes 08 and 12

230V LINE WIRING: USE COMPONENT LEADS OR 18 AWG BROWN UNLESS NOTED
 24V CONTROL WIRING: USE COMPONENT LEADS OR 18 AWG WHITE

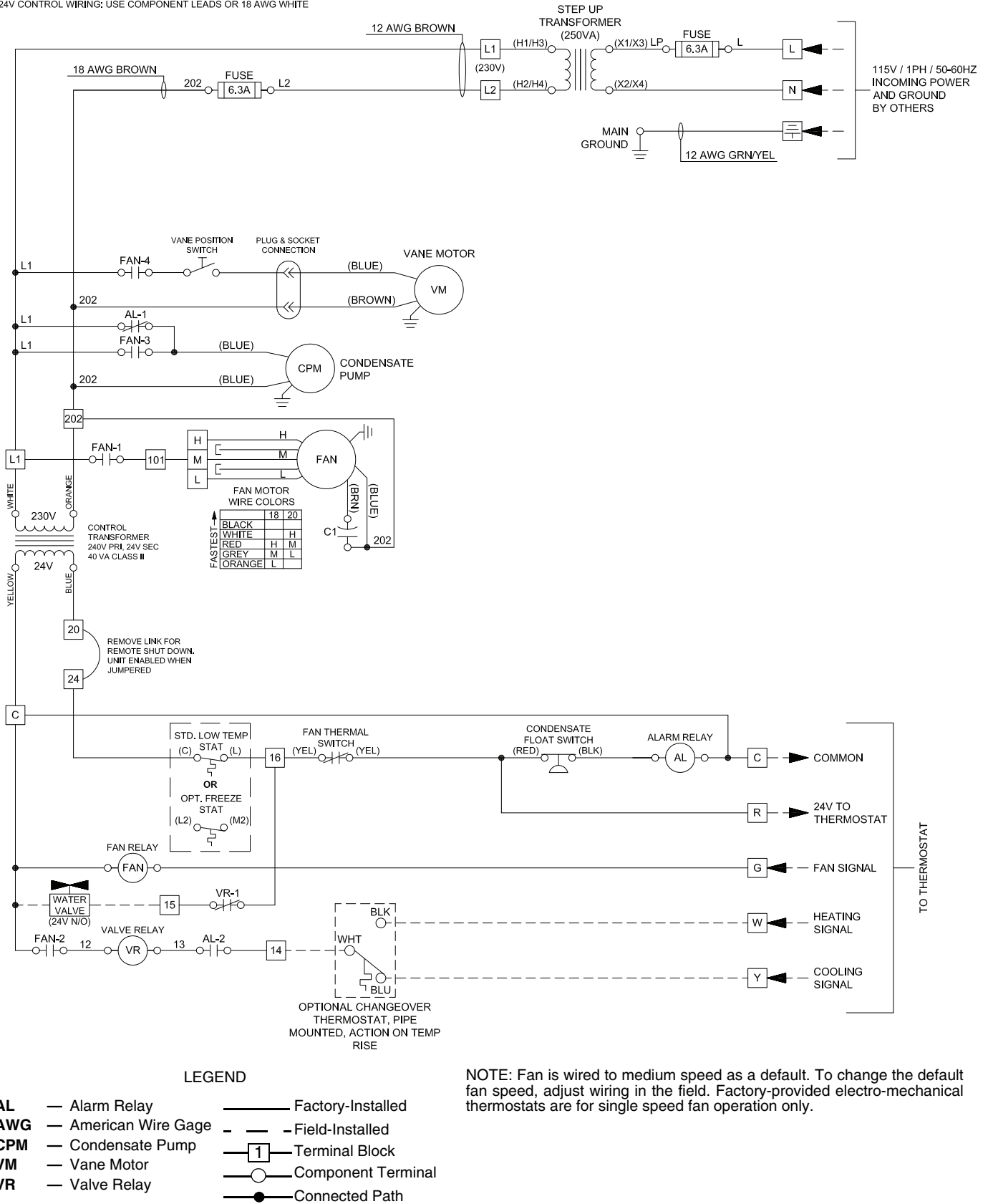
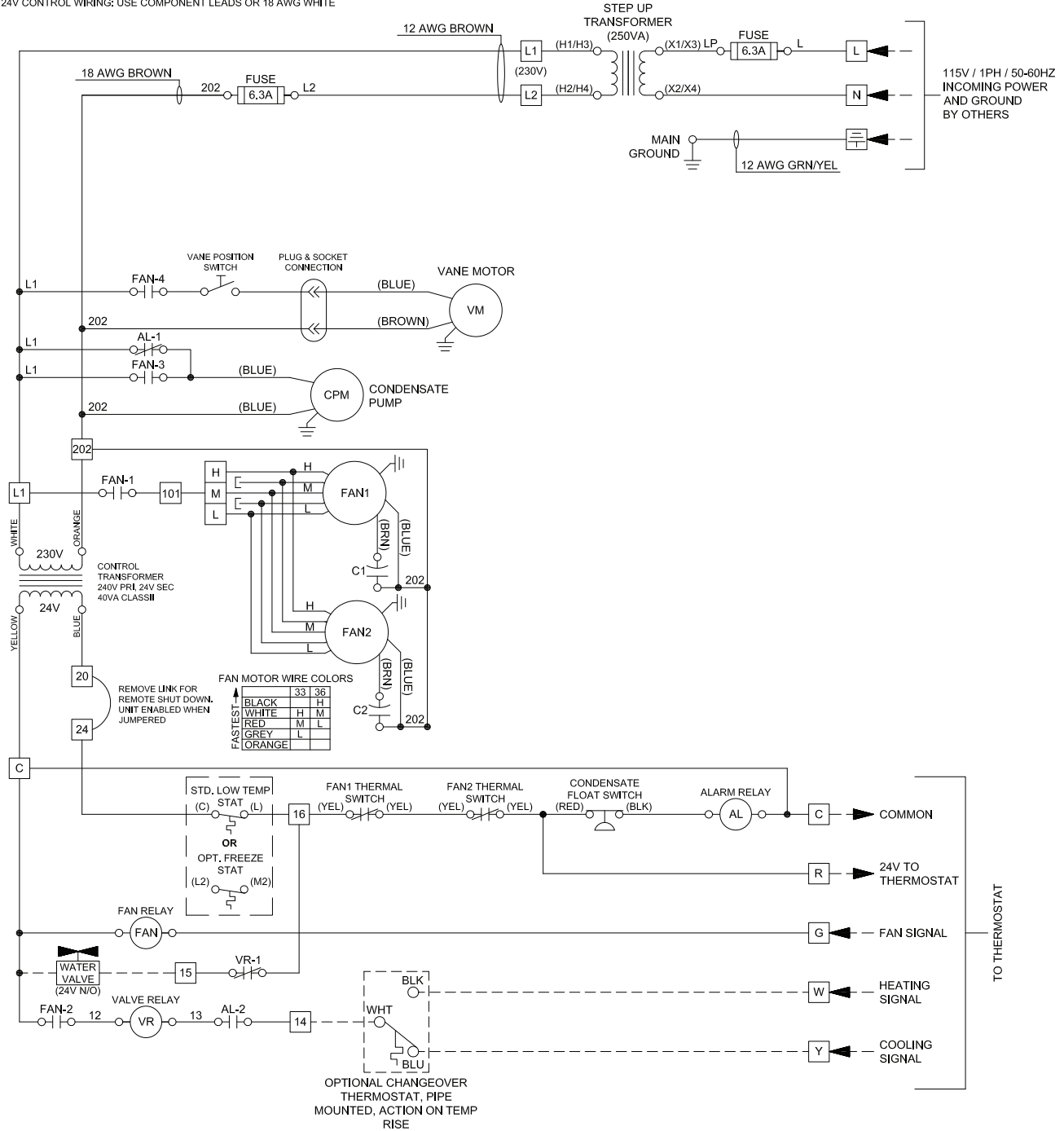

Fig. 49 — 42WKN Unit 2-Pipe System with Heating/Cooling Changeover, Aquastat, and Electro-Mechanical Control Wiring Diagram, Sizes 18 and 20

230V LINE WIRING: USE COMPONENT LEADS OR 18 AWG BROWN UNLESS NOTED
 24V CONTROL WIRING: USE COMPONENT LEADS OR 18 AWG WHITE



NOTE: Fan is wired to medium speed as a default. To change the default fan speed, adjust wiring in the field. Factory-provided electro-mechanical thermostats are for single speed fan operation only.

Fig. 50 — 42WKN Unit 2-Pipe System with Heating/Cooling Changeover, Aquastat, and Electro-Mechanical Control Wiring Diagram, Sizes 33 and 36

230V LINE WIRING: USE COMPONENT LEADS OR 18 AWG BROWN UNLESS NOTED
 24V CONTROL WIRING: USE COMPONENT LEADS OR 18 AWG WHITE

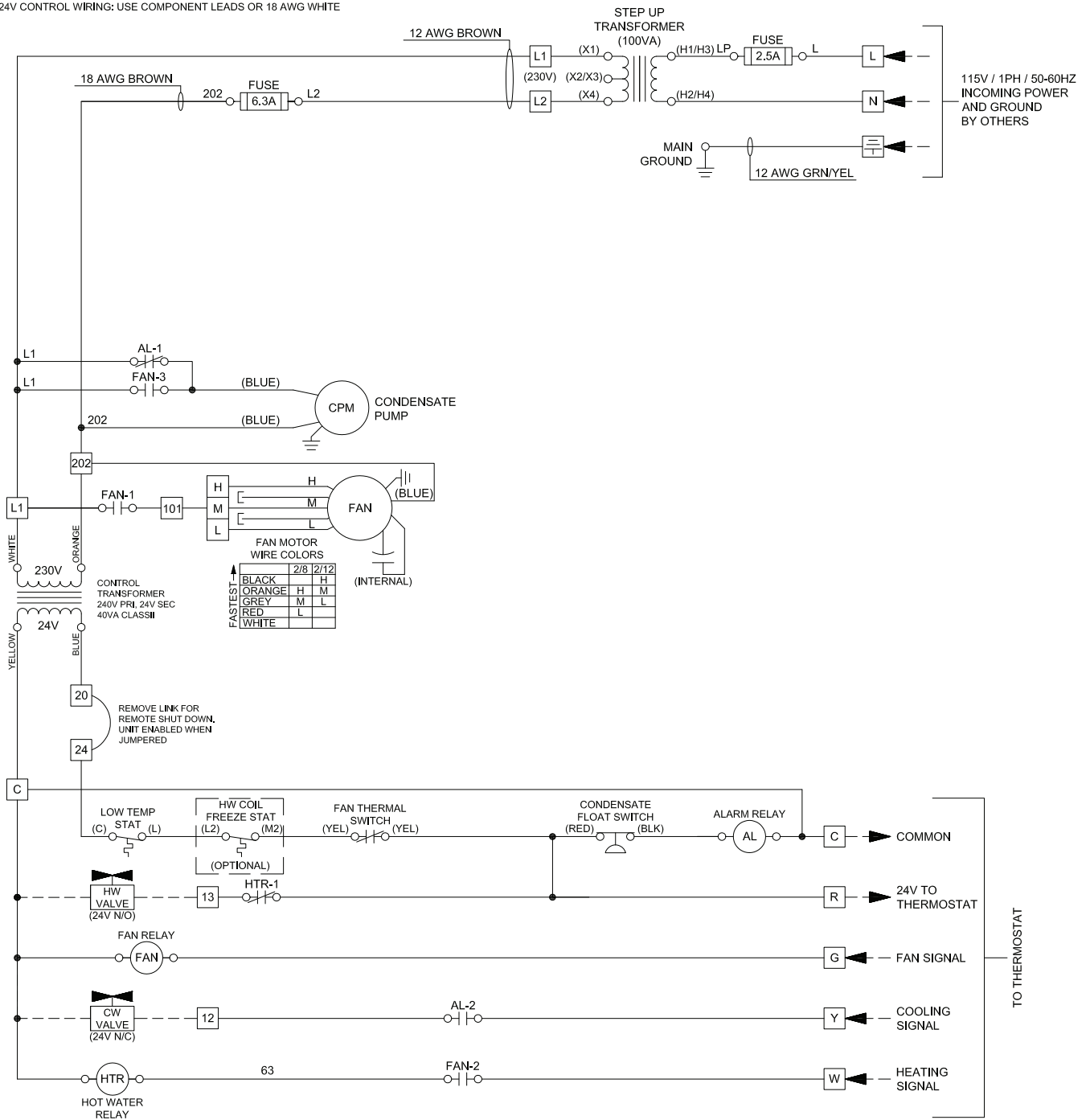

LEGEND

- AL** — Alarm Relay
- AWG** — American Wire Gage
- CPM** — Condensate Pump
- CW** — Chilled Water
- HTR** — Hot Water Relay
- HW** — Hot Water
- Factory-Installed
- - - - - Field-Installed
- [] Terminal Block
- Component Terminal
- Connected Path

NOTE: Fan is wired to medium speed as a default. To change the default fan speed, adjust wiring in the field. Factory-provided electro-mechanical thermostats are for single speed fan operation only.

Fig. 51 — 42WKN Unit 4-Pipe System with Hot Water Coil and Electro-Mechanical Control Wiring Diagram, Sizes 08 and 12

230V LINE WIRING: USE COMPONENT LEADS OR 18 AWG BROWN UNLESS NOTED
 24V CONTROL WIRING: USE COMPONENT LEADS OR 18 AWG WHITE

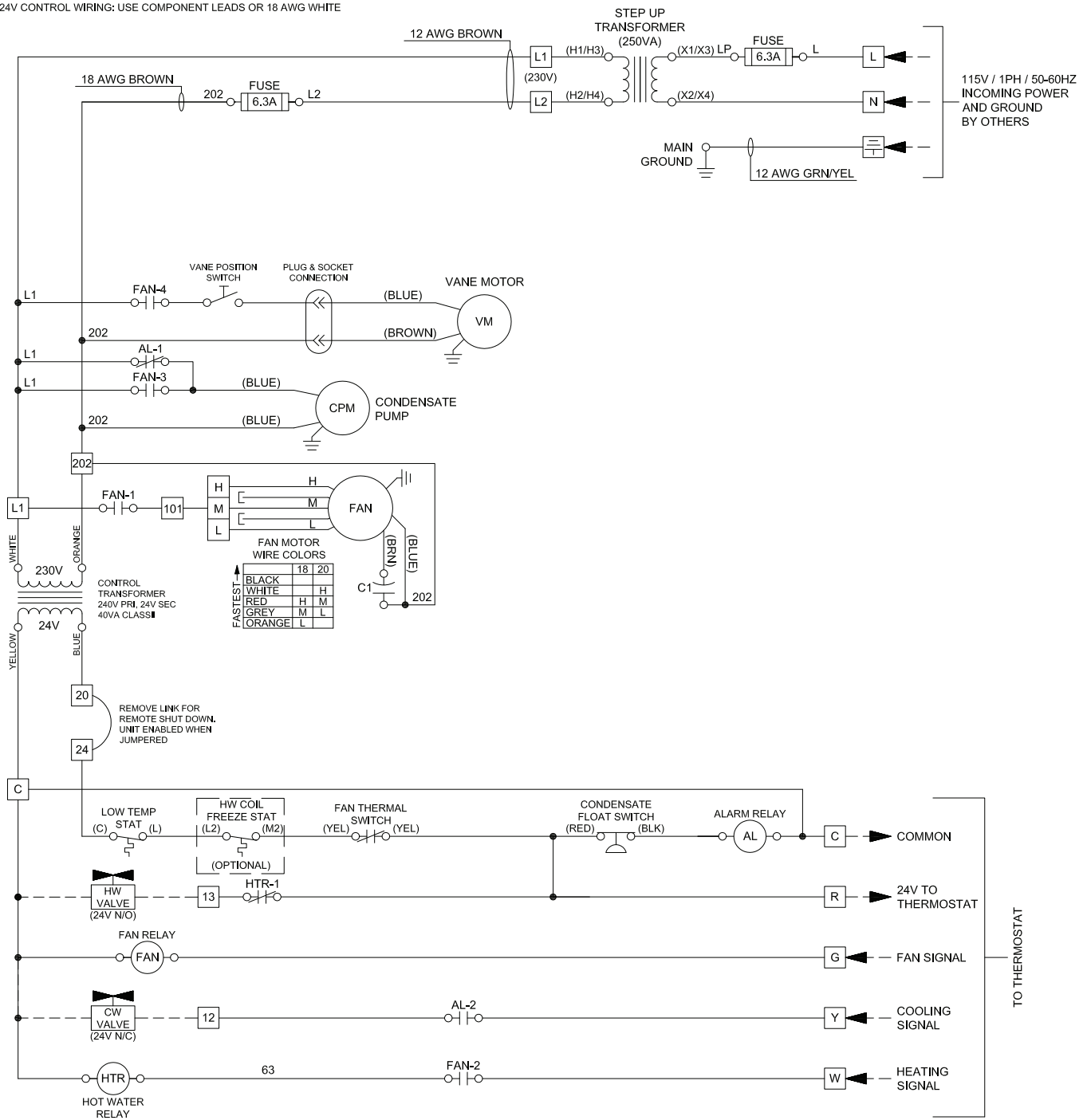

LEGEND

- AL** — Alarm Relay
- AWG** — American Wire Gage
- CPM** — Condensate Pump
- CW** — Chilled Water
- HTR** — Hot Water Relay
- HW** — Hot Water
- VM** — Vane Motor
- Factory-Installed
- - - - - Field-Installed
- 1 Terminal Block
- Component Terminal
- Connected Path

NOTE: Fan is wired to medium speed as a default. To change the default fan speed, adjust wiring in the field. Factory-provided electro-mechanical thermostats are for single speed fan operation only.

Fig. 52 — 42WKN Unit 4-Pipe System with Hot Water Coil and Electro-Mechanical Control Wiring Diagram, Sizes 18 and 20

230V LINE WIRING: USE COMPONENT LEADS OR 18 AWG BROWN UNLESS NOTED
 24V CONTROL WIRING: USE COMPONENT LEADS OR 18 AWG WHITE

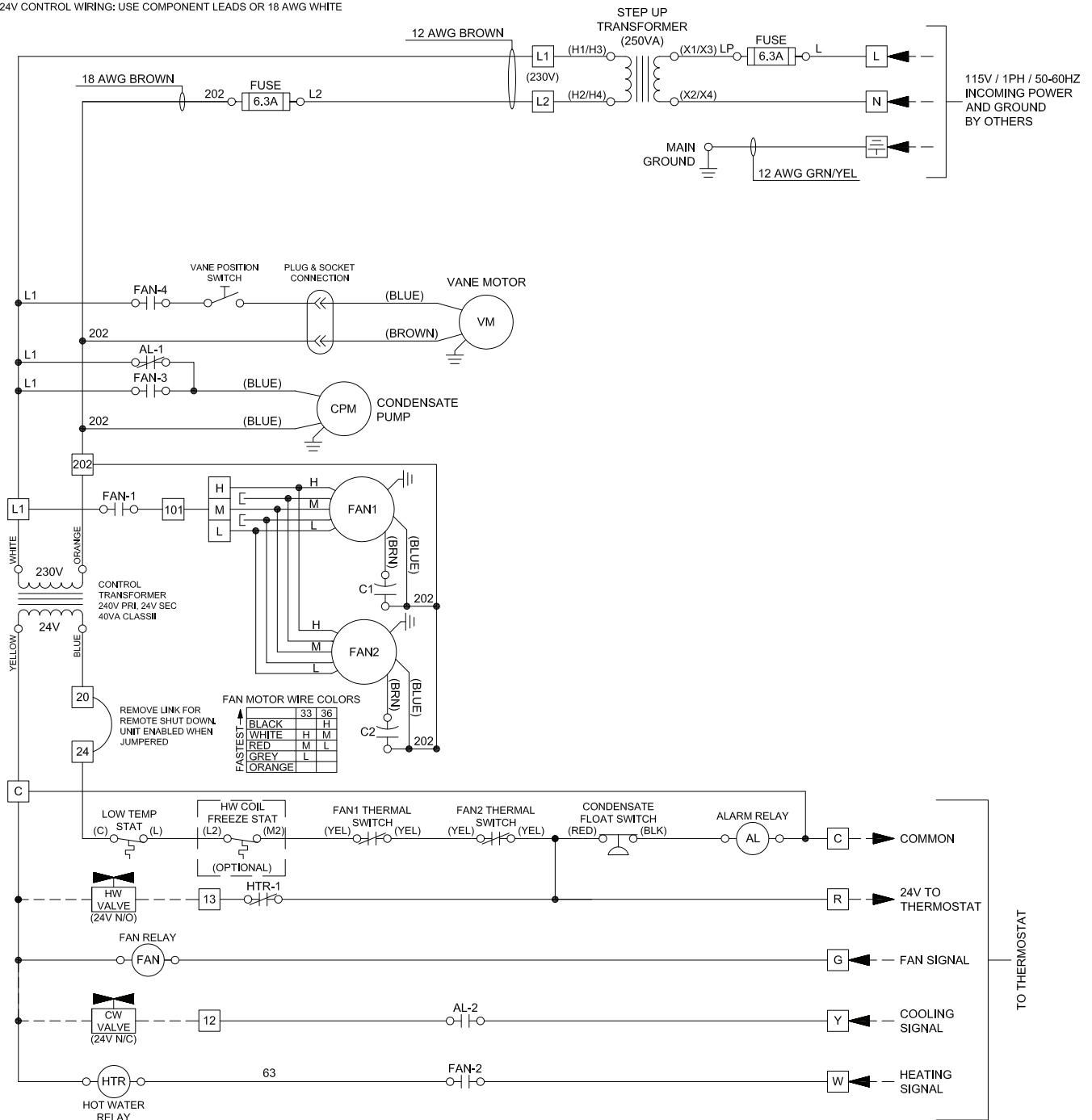

LEGEND

- AL** — Alarm Relay
- AWG** — American Wire Gage
- CPM** — Condensate Pump
- CW** — Chilled Water
- HTR** — Hot Water Relay
- HW** — Hot Water
- VM** — Vane Motor
- Factory-Installed
- - - - - Field-Installed
- [1] Terminal Block
- Component Terminal
- Connected Path

NOTE: Fan is wired to medium speed as a default. To change the default fan speed, adjust wiring in the field. Factory-provided electro-mechanical thermostats are for single speed fan operation only.

Fig. 53 — 42WKN Unit 4-Pipe System with Hot Water Coil and Electro-Mechanical Control Wiring Diagram, Sizes 33 and 36

Fascia Assembly

Once the piping and electrical services have been connected, the 4 fascia mounting bolts can be unscrewed approximately 1-in. from the condensate tray support channels.

The fascia can now be unpacked for fitting to the unit chassis. Ensure the black fir tree fasteners holding the fascia polystyrene are pushed in firmly in case of transit vibration. If using branch ducting, the fascia aperture side opposite the ducting must be blanked off. Take one of the polystyrene blanking pieces and push it into the recess in the polystyrene fascia insulation. See Fig. 54. Install the fascia by removing the inlet grilles and filters, locating the 4 fascia mounting bolts on the chassis through the 4 keyhole brackets on the fascia and then sliding the fascia sideways until it locks into position.

NOTE: Up to 2 non-adjacent sides can be blanked off.

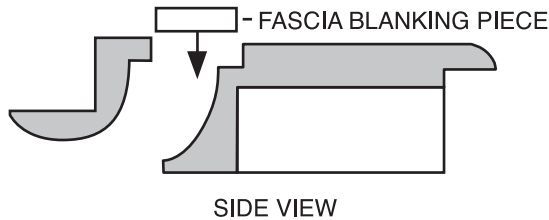

Fig. 54 — Blanking Off Fascia

NOTE: Make sure the foam insulating strip profile on the fascia matches the square and angled corners of the unit housing.

Before tightening the fascia to the unit, connect the 2 halves of the vane motor's plug and socket connection (unit sizes 18-36).

On microprocessor-controlled units, ensure that the display panel cable is routed to the electrical panel and securely fastened to its connector on the microprocessor circuit board. (Refer to the unit's electrical wiring schematic.) Take care to ensure that the connector is connected in the proper orientation and that the wires are not routed such that they may become trapped, cut, broken or chaffed.

The fascia can now be tightened up to the unit chassis until a good seal is obtained between fascia and chassis.

NOTE: Do not over tighten the bolts. To do so may cause damage to the fascia.

Reinstall filters in fascia. The inlet grilles can now be fitted to the fascia to complete the installation.

PRE-START-UP

IMPORTANT: Start-up and adjustment procedures should be performed by a qualified service agency.

See the start-up sheet example in Fig. 55. A start-up sheet is supplied with the unit.

Pre-Start Checks

Once installation is complete, it is important that the following pre-start checks are made:

1. All piping is complete and insulated where necessary.
2. All fans are able to rotate freely.
3. All electrical connections (both power and control) are properly terminated.

4. All condensate drains are installed correctly.
5. The power supply is of the correct voltage and frequency.
6. The units are properly grounded in accordance with current electrical codes.
7. For microprocessor-controlled units, check that the display panel cable is properly connected to the microprocessor main circuit board and that the jumper links are correctly set (refer to unit wiring schematic). If the links are set incorrectly, remove main power supply before making any changes.
8. For microprocessor-controlled units, check that the battery on the main circuit board is in place and properly connected. Check also that the batteries are installed in infrared/pendant transmitter. When a pendant transmitter is used, ensure it is properly located on to the wall mounting bracket.

Control Circuit Checks

A thorough pipe work check and pressure test should be performed before the unit controls are set up.

1. Isolate the unit from the chilled water supply. A system electrical check can now be carried out.
2. Switch on the indoor unit via the infrared/pendant transmitter or wall-mounted thermostat and check that the fan cycles correctly.

NOTE: In some models there is a 2-minute fan run on time to remove residual heat from the unit if the unit is switched off during the heating mode.

3. On models with microprocessor controls, check that the high, medium and low fan speeds are operating correctly by changing the fan speed via the transmitter.
4. On unit sizes 18-36, check that the motorized vane sweep functions correctly by toggling the function on or off, either via the transmitter (microprocessor-controlled units) or via the toggle switch on the side of the electrical panel lid (electro-mechanical units).
5. On microprocessor-controlled units, if required, check that the built-in timer function is programmed and operating correctly. When the timer is activated, the red LED on the fascia display panel should be lit.
6. Check the operation of the condensate pump by pouring 7 to 8 ounces of water down the pump outlet, switch the unit on, select cooling mode and the lowest possible temperature set point, then observe the water being pumped from the unit.
7. Check the operation of the chilled water valve by switching the system to the cooling mode and forcing a call for cooling.
8. Where fitted, check the operation of the hot water valve or the electrical heat elements by switching the system to the heating mode and forcing a call for heat.
9. Allow chilled water to enter the unit and vent air from the unit by opening the 1/4-in. air bleed. Re-tighten the bleed screw once all air has been removed.

The units are now ready for the system balance to be performed.

CASSETTE START UP SHEET

Date	<input type="text"/>	Job Reference	<input type="text"/>	Tag ID	<input type="text"/>
Serial #	<input type="text"/>	Unit Model	<input type="text"/>	Room ID	<input type="text"/>
Drawing #	<input type="text"/>	Installer	<input type="text"/>		
Sales Rep	<input type="text"/>				

Pre-Start up Checklist

Unit Satisfactory	Comments:	<input type="text"/>							
Dry Nitrogen Pressure Test	Initial Test Pressure	<input type="text"/>	<input type="text"/>	<input type="text"/>	Psig				
	Final Test Pressure	<input type="text"/>	<input type="text"/>	<input type="text"/>	Psig				
	Test Duration	<input type="text"/>	<input type="text"/>	<input type="text"/>	Mins				
PCB Jumpers links set.	<u>J1</u> On	Off	<u>J2</u> On	Off	<u>J3</u> On	Off	<input type="text"/>	<input type="text"/>	<input type="text"/>
All Electrical Connections Tight	(Indoor, Outdoor & Thermostat)				<input type="text"/>	<input type="text"/>	<input type="text"/>		

Indoor Unit Checklist

Supply Voltage	Primary	<input type="text"/>	Secondary	<input type="text"/>	Low Volt	<input type="text"/>
Unit Level						<input type="text"/>
Unit Cycled On / Off						<input type="text"/>
Fan Speeds Correct	(Microprocessor only)					<input type="text"/>
Vane Sweep Operates	(N/a on 2/ units, manually positioned vanes)					<input type="text"/>
High Water Level Safety Operates	(High water level in sump disables cooling signal)					<input type="text"/>
Internal Pump ejects test water	(10 fl oz)					<input type="text"/>
Drain Installed Correctly	(Maximum Pump Lift, 30 Inch)					<input type="text"/>
Timer Functions Set	(Microprocessor only, Infra Red & Pendant)					<input type="text"/>
Set Points	Mode	<input type="text"/>	Fan Speed	<input type="text"/>	Temp	<input type="text"/> °F

Technician's Notes

Customer Feedback: Please relay any comments about Quality or Service

NOTE: Any feedback may be submitted by fax to either the sale engineer or to the local Carrier office.

Fig. 55 — Start-Up Sheet Example

Sequence of Operation

ELECTRO-MECHANICAL CONTROLS

A 24-v signal from the thermostat to terminal G supplies power to the blower motor(s), condensate pump, and vane motor (if equipped). A toggle switch on the control box can be used to switch the oscillating vanes on or off. The condensate pump will run continuously, as long as the blower is energized. A call for heating, at terminal W, or cooling, at terminal Y, will energize the water valve actuator and allow water to flow through the cassette coil. When the call for heating or cooling is satisfied, the valve will close.

If the temperature drops below the set point of the coil freestat, the water valve will automatically open to circulate water through the coil.

If the condensate float switch detects a high level of water in the condensate tray, the switch will open, activate the condensate pump and disable the heating/cooling signal until the water level drops down to normal.

MICROPROCESSOR CONTROLS

The microprocessor monitors indoor coil temperature and return-air temperature. The receiver contains a self-diagnostic feature. When a low indoor coil temperature is detected, the cooling action is stopped. If a sensor fails, then an alarm is displayed on the fascia mounted receiver.

OPERATION

When using the IR transmitter (see Fig. 35), always point the transmitter head directly at the receiver. At the time of transmission, the transmit indicator symbol will display and an audible alarm will be heard if the signal has been received.

When the batteries are first installed, the transmitter or optional pendant default set point will be 64°F, low fan speed will be selected, and the system will be set to cool only mode.

When a parameter is changed in the Remote Control, it must be sent to the thermostat by pressing ON/SEND.





Refer to Fig. 35 for button locations.

On/Off

Press the ON/SEND button to activate the air conditioner / fan coil unit and/or update information.

Fan Speeds





Press the FAN button to switch between fan speeds:

- High Speed 
- Medium Speed 
- Low Speed 
- Auto Speed 

Press the ON/SEND button to send information to thermostat.

Modes

Press the MODE button to switch between unit modes:

- Cool 
- Heat 
- Auto change-over 
- Fan only 

Press the ON/SEND button to send information to thermostat.

Temperature Setpoint

Adjust the desired temperature using the (+) or (-) buttons. Press the ON/SEND button to send information to thermostat.

Clock

1. Press the SELECT button. CLOCK SET will flash.
2. Press the (+) or (-) buttons. The hours will flash.
3. Adjust the hours using the (+) or (-) buttons.
4. Press the SELECT button again. Minutes will flash.
5. Adjust the minutes using the (+) or (-) buttons.
6. Press the SELECT button again to return to normal display mode.
7. Press the ON/SEND button to send information to the thermostat.

Timer

IMPORTANT: While setting the timer, if no button is pressed for 10 seconds, the display will return to normal display mode.

Start Time

1. Press the SELECT button twice. PROGRAM and START (flashing) will appear on display.
2. Press the SELECT button. The hours will flash.
3. Adjust the hours using the (+) or (-) buttons.
4. Press the SELECT button. The minutes will flash.
5. Adjust the minutes using the (+) or (-) buttons.

Stop Time

1. Press the SELECT button. PROGRAM & STOP (flashing) will appear on display.
2. Press the SELECT button. The hours will flash.
3. Adjust the hours using the (+) or (-) buttons.
4. Press the SELECT button. The minutes will flash.
5. Adjust the minutes using the (+) or (-) buttons.
6. Press the SELECT button. The TIMER will blink.
7. Select TIMER ON (black timer icon) or OFF (white timer icon) using the (+) or (-) buttons.
8. Press the ON/SEND button to send the information to the thermostat.

NOTE: When the Timer is active, and there is power failure to the thermostat, the display will show "ON" flashing.

Battery Replacement

When the batteries are low, the remote control display will dim. If the batteries are not replaced, the display will turn off completely.

1. Pull the battery cover down to reveal the batteries.
2. Remove the old batteries.
3. Wait for 10 minutes before installing the new batteries.
4. Install 2 new AAA batteries. Pay attention to the polarity.
5. Replace the battery cover.

IMPORTANT: The remote control will not operate unless at least 10 minutes pass between removing the old batteries and installing the new ones.

CONTROLS

Setting Jumper Links

⚠ WARNING

Disconnect power supply before making wiring connections to prevent electrical shock and equipment damage. All appliances must be wired strictly in accordance with wiring diagram furnished with the appliance. Use of any other wiring diagram could result in a hazard to persons and property.

⚠ CAUTION

Any original factory wiring that requires replacement must be replaced with wiring material having a temperature rating of at least 105°C.

Ensure that the supply voltage to the appliance, as indicated on the serial plate, is not more than 5% over rated voltage. Failure to follow these recommendations may result in equipment damage.

Jumper links are located on the microprocessor controller PCB to offer different control features and their functionality is listed in Table 4:

Table 4 — Jumper Link Control Features

JUMPER LINKS	SHORT (ON)	OPEN (OFF)
JMP1	In heat or cool modes, fan operates in auto mode.	In cool mode, fan runs continuously. In heat mode, fan runs on demand.
JMP2	4-pipe configuration: Cool output connected to cooling device. Heat output connected to heating device.	2-pipe configuration: Cooling and heating signals sent from cool output.
JMP3	N/A	N/A

Jumper link settings must be made with the power turned off. Jumper link 1 will be factory set to SHORT, Jumper link 2 will be factory set to suit the type of unit, and Jumper link 3 will be factory set to OPEN.

Main Control Functions

INDOOR FAN OPERATION

The indoor fan will run continuously at the most recently set speed or will alter the speed according to the room temperature conditions when set to Auto mode. The indoor fan will continue to run until the unit is turned off by the user or via a pre-set time setting. When the unit is turned off during heating, the indoor fan will continue to run for approximately 2 minutes; this helps to dissipate residual heat from the electric heaters. In SLEEP mode the fan will cycle with a call for heating or cooling.

TEMPERATURE CONTROL

The controller will switch heating or cooling loads in order to maintain the temperature set point. The deadband is programmed to 4°F. Under normal operation, cooling or heating will be activated at the limits of the deadband and will continue to operate until set point is achieved.

The temperature set point can be adjusted between 58°F and 90°F in 2°F increments.

POWER FAILURE

The controller will auto restart in its previous mode of operation after a power failure, e.g., if the controller was turned on before power fail, after power is restored the controller will

automatically turn on. Alternatively, if the controller was turned off before power fail after power is restored, the controller will remain off.

Alarms

The controller monitors the following alarm conditions:

- Return-air sensor failure
- Indoor coil under temperature (if freeze stat is on unit)
- Condensate high level

MAINTENANCE

⚠ CAUTION

When servicing or repairing this equipment, use only factory-approved service replacement parts. Refer to the rating plate on the appliance for complete appliance model number, serial number and company address. Any substitution of parts or controls not approved by the factory will be at the owner's risk. Failure to follow these recommendations may result in equipment damage.

⚠ CAUTION

To prevent equipment damage, do not attempt to reuse any mechanical or electrical controllers which have been wet. Replace defective controller.

Maintenance Schedule

EVERY 3 MONTHS

Check the air filter condition. Clean if necessary (see Filter Removal and Cleaning below).

EVERY 6 MONTHS

1. Follow 3-month maintenance schedule in addition to below steps.
2. Clean condensate tray with biocide suitable for polystyrene.
3. Clean fascia.

EVERY 12 MONTHS

1. Follow 6-month maintenance schedule in addition to below steps.
2. Check all electrical connections for security.
3. Check condensate pump operation.
4. Check the heating and cooling action, to ensure proper operation.

Filter Removal and Cleaning

1. Disconnect power.
2. Unclip the catches along the edge of each grille and allow them to hang from the fascia by the molded plastic hinges located along the opposite edge.
3. If desired, the grilles can be removed from the fascia completely.
4. Slide the filter out of the small plastic retaining clips on the back of each grille.
5. Gently vacuum clean the filters on a medium vacuum power.
6. When cleaned, reverse Steps 2-4 to replace the filters.

Recommended Spares

It is recommended that one complete set of air filters be kept on hand for use as needed.

DISASSEMBLY PROCEDURE

WARNING

Disconnect power supply before disassembly to prevent electrical shock and injury from moving parts.

Fan Removal

1. Unclip the grille catches and remove the grille(s) from the fascia.
2. For unit sizes 08,12 only:
 - a. Remove the fascia by loosening the 4 fascia mounting bolts and then slide the fascia horizontally until it releases from the chassis.
 - b. Drain the condensate tray by removing the small black rubber drain plug, catching the condensate (if any) in a suitable container.
 - c. Remove the self-tapping screws securing the two insulated metal condensate tray support channels and pull the channels away from the condensate tray.
 - d. Pull the condensate tray downwards away from the chassis.

For unit sizes 18-36 only:

Remove the M6 screws from the black plastic inlet ring and pull the inlet ring downward from the condensate tray.

3. Remove the electrical panel lid and disconnect the fan connections from within the electrical panel.
4. Rotate the fan by hand until the 2 M6 nuts are visible through the fan mounting access holes. Remove the 2 nuts.
5. Rotate the fan 90 degrees until the remaining 2 nuts are visible and remove while supporting the fan to prevent it

from falling. The fan can now be dropped down from the unit.

Condensate Tray Removal

1. Unclip the grille catches and remove the grille(s) from the fascia.
2. Remove the fascia by loosening the fascia mounting bolts and then slide the fascia horizontally until it releases from the chassis. If the unit is microprocessor controlled, remove the display panel cable from within the electrical panel before removing the fascia.
3. Drain the condensate tray by removing the small black rubber drain plug, catching any condensate in a suitable container.
4. Remove the self-tapping screws securing the 2 insulated metal condensate tray support channels and pull the channels away from the condensate tray. Pull the condensate tray, complete with inlet ring (inlet ring on unit sizes 18-36 only) downward away from the chassis.

Condensate Pump Removal

1. Disconnect the condensate pump and float switch wires from inside the electrical panel.
2. Unscrew the 3 M4 screws holding the pump inspection plate in place and pull the pump and mounting bracket away from the chassis while feeding the pump wires between condensate tray and insulation.

TROUBLESHOOTING

See Table 5 for troubleshooting information.

Table 5 — Troubleshooting

PROBLEM	POSSIBLE CAUSE	POSSIBLE SOLUTION
Two LEDs Flashing (Microprocessor Units Only)	Faulty float switch (Connected to microprocessor terminals 'T4')	See Condensate High Level section in this table.
	Fan thermal trip (Connected to microprocessor terminals 'T4')	See Fans Will Not Run section in this table.
	Freeze stat alarm (Connected to microprocessor terminals 'T4')	See Coil Freeze section in this table.
	Return air sensor failure (Connected to microprocessor terminals 'T1')	After checking the above, use the unit wiring schematic to isolate the return air sensor and measure the resistance. Sensor is 50K at 72°F type. Check and replace if necessary.
Unit Will Not Operate	No power mains power	Check power supply to the unit. For microprocessor units, check power to the microprocessor and check the on-board microprocessor fuse.
	No 24-v control circuit power	Check the 24-v feed from the control transformer. If not present, check transformer windings and replace if necessary.
	Control circuit disabled by unit protection device	In some models, particularly electro-mechanical units, some protection devices (such as freezestats, fan trips, etc.) are wired in line with the 24-v control circuit feed to cause the unit to shut down in an alarm condition. Use the unit's wiring schematic to identify these devices and investigate accordingly.
	Infrared receiver failure (microprocessor units only)	If the green LED is lit or flashing, receiver is OK. If there are no lit LEDs and the unit will not respond to the transmitter, press the on/off button on the fascia display panel. If the unit responds to the on/off button receiver is OK. Check transmitter.
	Transmitter failure (microprocessor units only)	Try new batteries first. If no response, press on/off button on unit fascia. If the unit responds to the on/off button transmitter is faulty.
	Microprocessor failure (microprocessor units only)	The microprocessor is the least likely component to be at fault. Investigate all other possibilities in every section of this troubleshooting guide first. Replace the microprocessor only after all other avenues of investigation are exhausted.
Fans Will Not Run	Loose wire	Check all fan wire connections. Use unit's electrical schematic to verify that fan is wired correctly.
	Faulty fan capacitor	Check fan capacitors and replace if necessary.
	Faulty fan motor	Check fan motor protector for open circuit, and replace if necessary.
	Fan thermal trip	Motor temperature limits exceeded. Check fan motor protector for open circuit, and replace if necessary.
	Faulty PCB	On electro-mechanical units check for a signal at "G" terminal. On microprocessor units check for steady green light on display panel.
No Cooling	Incorrect MODE setting (microprocessor units only)	Check that the transmitter MODE is set to Cooling or Auto Mode.
	Set point too high	Check the set point on the transmitter or wall-mounted thermostat and adjust if necessary.
	Compressor protection delay (electro-mechanical DX units only)	Wait for 10 minutes, then re-check to determine if cooling is operating.
	Dirty or blocked air filter	See Coil Freeze section in this table.
	High condensate level trip	Drain the condensate tray and investigate. See Condensate High Level section.
	Indoor coil temperature too low	Check refrigerant charge by measuring operating pressures. Check filter condition. (See page 55 for filter removal and cleaning instructions.)
	Sensor failure (microprocessor units only)	If any of the sensors are faulty, the microprocessor will disable the cooling operation. (See the "Self Diagnostics" section on page 7.)
	Faulty valve actuator (chilled water units only)	Check cooling signal present at actuator. Check actuator by manually opening the valve. Replace actuator if necessary.
Condensate High Level (Microprocessor Units: LEDs Will Flash)	Maximum pump lift exceeded	Check that the condensate pump head is no greater than 30-in. (See page 39 of this manual for installation guide.)
	Blocked/kinked condensate pipe	See Water Leaking from Unit section in this table.
	Condensate pump blocked or failed	See Water Leaking from Unit section in this table.
	Coil freeze up	A coil freeze condition may have caused excessive condensate to collect in the drip tray. See Coil Freeze section in this table.

LEGEND

LED — Light-Emitting Diode
PCB — Printed Circuit Board

Table 5 — Troubleshooting (cont)

PROBLEM	POSSIBLE CAUSE	POSSIBLE SOLUTION
Coil Freeze	Cooling coil freeze protection thermostat tripped (Auto-reset when freeze cleared)	Freeze thermostat is normally closed, opens during freeze. Where fitted, the thermostat will disable the cooling action (sometimes the entire system) during coil freeze conditions. Use the unit's wiring schematic to investigate.
	Dirty or blocked air filter	Clean/replace filters as necessary. (See page 55 for filter removal and cleaning instructions.)
	System head pressure set too low.	Check condensing pressure. Low ambient kit installation may be required.
	Loss of refrigerant	Check system for refrigerant leaks and repair before recharging.
Water Leaking from Unit (also see Condensate High Level Section)	Condensate plug loose or missing	Check that the rubber condensate plug is securely fitted to the underside of the unit's polystyrene drip tray. On some models this is located underneath the fascia support rails on the pump side of the unit.
	Unit installed unevenly	With fascia removed, ensure that the unit chassis is level (at the face) both front to back and left to right, to ensure correct condensate flow.
	Condensate drain piping installed incorrectly	Check that the site installed condensate gravity drain slopes 'downhill' away from the unit. (See page 39 of this manual for installation guide.)
	Blocked/kinked condensate pipe	Check condensate piping for blocks/kinks, clear as necessary. Check for a water tight connection between the condensate outlet and the site installed condensate gravity drain.
	Condensate pump blocked or failed	Clear any blockages and ensure that power is being applied to the pump. If the pump still does not run, replace the pump.
	Float switch failure	Check that the float switch operates correctly and is properly positioned. Float switch is normally closed, opens on rise of water level.
No Heating (Hot Water)	Incorrect MODE setting (Microprocessor units only)	Check that the transmitter MODE is set to Heat or Auto Mode.
	Set point too low	Check the set point on the transmitter or wall mounted thermostat and adjust if necessary.
	Blocked or dirty filters causing low airflow	Check condition of filters. (See page 55 for filter removal and cleaning instructions.)
	No hot water/pumps failed	Check hot water source and supply to unit.
	Faulty valve/actuator	Check actuator by manually opening and closing valve, replace if faulty.
	Faulty heater relay	Check signals to relay and check action of relay contacts. Replace relay or PCB if necessary.
No Heating (Electric Heat)	Incorrect MODE setting (microprocessor units only)	Check that the transmitter MODE is set to Heat or Auto Mode.
	Set point too low	Check the set point on the transmitter or wall-mounted thermostat and adjust if necessary.
	Overheat cutout tripped (Also see Electric Overheat section)	Investigate cause of over heat condition. <ul style="list-style-type: none"> • Possible low airflow, check filter condition. (See page 55 for filter removal and cleaning instructions.) • Possible fan failure. Check fans. (See Fans Will Not Run section.) Remove power from unit and reset manual overheat cutout by rubbing. DO NOT PRESS. Consult Factory for instruction if necessary.
	Heater element failed	Investigate and replace if necessary.
	Faulty heater relay	Check signals to relay and check action of relay contacts. Replace relay or PCB if necessary.
Electric Overheat	Automatic or manual reset overheat cutout tripped	The electric heat circuit contains one automatic reset and one manual reset overheat cutout protection switch for each electric heat element fitted to the unit. The cutouts are wired in line with the main power flowing in each element and operate as described below. <ul style="list-style-type: none"> • Automatic cutout: If the auto cutout trips, the electric heat is temporarily disabled until the unit temperature falls and causes the overheat cutout to automatically reset. • Manual cutout: If the manual cutout trips, the electric heat is disabled until the unit temperature falls and the overheat cutout is manually reset. It will typically take five minutes for the unit temperature to fall sufficiently to allow the cutout to be reset. The cutout should only be reset by a qualified and competent electrician and with the main power switched off. Ensure the elements have cooled sufficiently.

LEGEND

LED — Light-Emitting Diode
PCB — Printed Circuit Board

REPLACEMENT PARTS

Please quote the unit type and unit serial number when ordering replacement parts or contacting the factory about the unit. This information can be found on the serial plate attached to the unit. See Fig. 56.

When a component part fails, contact your local Carrier representative to order a replacement part. See Fig. 57 and 58 for the 42WKN unit exploded views and parts lists. If the part is considered to be under warranty, the following details are required to process this requirement:

1. Full description of part required, including the unit's part number, if known.
2. The original equipment serial number.
3. An appropriate purchase order number.



1500 DeKoven Avenue
Racine, WI 53403-2552

CEILING CASSETTE UNIT

MADE IN U.S.A.

Unit Type: 42WKN18 EM	HOT WATER COIL: MAX TEMP PRESSURE 200 F 125 PSIG
Serial Number: 999999-0000500808-1001	DESIGN PRESSURE: 500 PSIG
Clearance to Combustibles: 0" Maximum Discharge Temp: 125 F	REFRIGERANT TYPE: n/a
Voltage Rating: 208-230V/1Ph/60Hz	FACTORY CHARGE: 0 LB.
Blower Motor: QTY 0.5 FLA, 1/8 HP, 1	FIELD CHARGE:
Wiring Diagram: 5H102770-2100	Electric Heat: n/a kW, n/a
UNIT ELECTRICAL RATINGS:	
FLA	MCA
0.9 A	1.1 A
	MOP
	10.0 A

REPLACEMENT PARTS:

Supply Fan: 5H100102	Filter: 5H100856-0001
Capacitor: 5H100098	Relay: 5H100011
Condensate Pump: 5H100105	Drain Pan: 5H100182
Evaporator Coil: 3H100759	Freeze Stat: 5H100036

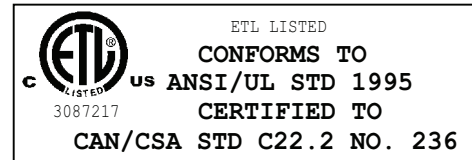

5H1015569, REV. C

Fig. 56 — Serial Plate Example

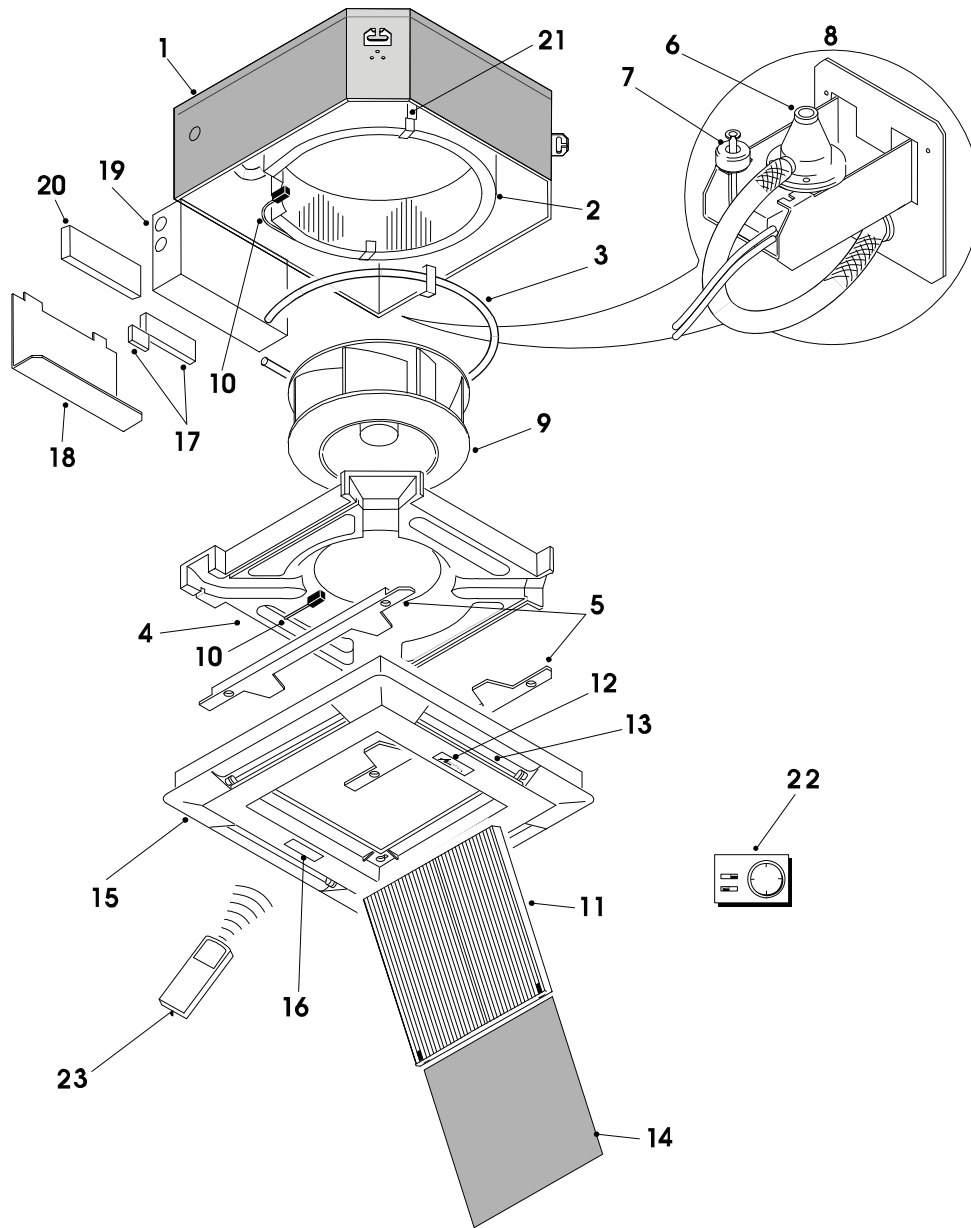

DESCRIPTION	
1	Cassette Chassis
2	Chilled Water Coil
3	Electric Heater Element Assembly
4	Condensate Tray
5	Condensate Tray Supports (2)
6	Condensate Pump
7	High Level Switch
8	Condensate Pump Assembly (Shown Inverted)
9	Fan/Motor Assembly
10	Coil/Return Air Sensors (Microprocessor Only)
11	Grille
12	Label

DESCRIPTION	
13	Air Deflector Vanes (4)
14	Filter
15	Fascia Assembly
16	Receiver (Microprocessor Only)
17	Terminal Rail, Relays and Timer
18	Control Box Lid
19	Control Box
20	PCB Controller (Microprocessor Only)
21	Coil Support Brackets
22	Wall Mounted Controller (Electro-Mechanical Only)
23	Remote Handset (Microprocessor Only)

Fig. 57 — 42WKN08, 12 Unit Exploded View and Parts List