

**40RUQ07-25**  
**Split System Heat Pump**  
**Indoor Unit (Air-Handling Unit)**  
**With Puron® Refrigerant**  
**60 Hz**



## Product Data



40RUQ 07 - 12

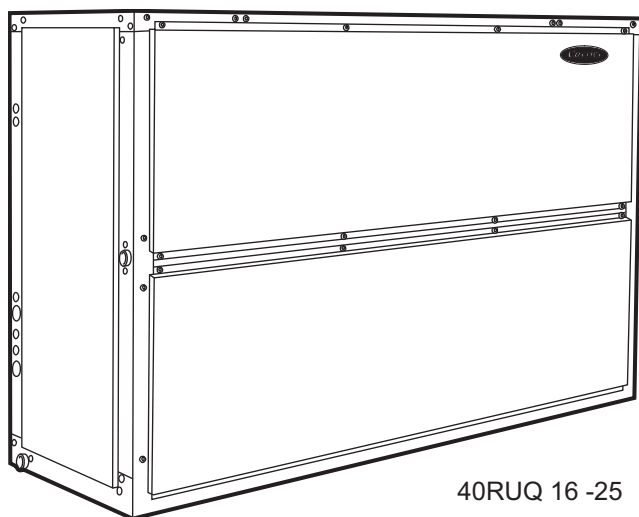

40RUQ 16 -25

C10887

Carrier's versatile packaged heat pump air-handling units satisfy design requirements with:

- Multi-position design for horizontal or vertical installation without modification.
- Standard sloped drain pans and cleanable insulation treated with Environmental Protection Agency (EPA) registered antimicrobial agent improve indoor air quality.
- High-static design meets a wider range of applications than competitive packaged air handler lines.
- Economizer accessory provides ventilation air and "free" cooling.
- Cooling coils with mechanically bonded fins provide peak heat transfer.
- Hot water coil, steam coil, and electric heat accessories are available.
- Standard factory-installed thermo-static expansion valves (TXV) with removable power element on 40RUQ units.
- Die-formed galvanized steel casings provide durability and structural integrity. Optional paint is available.

### FEATURES/BENEFITS

**Easy-to-install and economical 40RU units provide reliable service.**

The 40RUQ Series units with direct-expansion coils are the best choice for packaged heat pump air handlers. All models offer excellent fan performance, a unique combination of indoor air quality features, easy installation, and affordable prices. Their versatility and state-of-the-art features will provide economical performance now and in the future.

#### Indoor air quality features

The unique combination of features in the 40RUQ Series air handlers ensures that clean, fresh, conditioned air is delivered to the occupied space.

Cooling coils prevent the build-up of humidity in the room, even during part-load conditions.



## FEATURES/BENEFITS (cont.)

Two-inch (51-mm) disposable filters remove dust and airborne particles from the occupied space.

Thermal insulation contains an immobilized anti-microbial agent to inhibit the growth of bacteria and fungi. The anti-microbial agent is registered with the U.S. Environmental Protection Agency (EPA).

Pitched drain pan can be adjusted for a right-hand or left-hand connection to provide positive drainage and prevent standing condensate. Each unit contains two separate drain pans which are provided for either vertical or horizontal fan coil positions.

Accessory economizer can provide ventilation air to improve indoor air quality. When used with CO<sub>2</sub> sensors, the economizer admits fresh outdoor air to replace stale, recirculated indoor air.

### Economy

The 40RUQ Series packaged air handlers have low initial costs, and they continue to save money by providing reduced installation expense and energy-efficient performance.

Quick installation is ensured by the multi-position design. Units can be installed in either the horizontal or vertical (upflow) configuration without modifications. All units have drain-pan connections on both sides, and pans can be pitched for right-hand or left hand operation with a simple adjustment.

Fan motors and contactors are pre-wired and TXVs are factory-installed on 40RUQ models.

High-efficiency, precision balanced fans minimize air turbulence, surging, and unbalanced operation, thereby cutting operating expenses.

Economizer accessory precisely controls the blend of outdoor air and room air to achieve comfort levels. When the outside air enthalpy is suitable, outside air dampers can fully open to provide “free” cooling.

### Rugged dependability

Die-formed galvanized steel panels ensure structural integrity under all operating conditions. Mechanically bonded coil fins provide improved heat transfer. Galvanized steel fan housings are securely mounted to a die-formed galvanized steel deck.

### Coil flexibility

Model 40RUQ air handling units have galvanized steel casings; inlet and outlet connections are on the same end.

Direct expansion (DX) coils are designed for use with Puron® R-410A refrigerant and have copper tubes mechanically bonded to aluminum sine-wave fins.

Direct-expansion coils include matched, factory-installed thermostatic expansion valves (TXVs) with matching distributor nozzles.

### Easier installation and service

The multi-position design and component layout allow for quick unit installation and operation. The DX coils have factory-installed TXVs with matching distributor nozzles. Units can be converted from horizontal to vertical operation by simply repositioning the unit.

Drain pan connections are duplicated on both sides of the unit. The filters, motor, drive, TXVs, and coil connections are easily accessed by removing a single side panel.

## TABLE OF CONTENTS

	PAGE
FEATURES AND BENEFITS .....	1
MODEL NUMBER NOMENCLATURE .....	3
PHYSICAL DATA .....	4
OPTIONS AND ACCESSORIES .....	5
DIMENSIONS .....	6
PERFORMANCE DATA .....	15
ELECTRICAL DATA .....	20
TYPICAL PIPING AND WIRING .....	30
TYPICAL CONTROL WIRING SCHEMATIC .....	32
APPLICATION DATA .....	33
GUIDE SPECIFICATIONS .....	36

# MODEL NUMBER NOMENCLATURE

Position	1	2	3	4	5	6	7	8	9	10	11	12	13	14	15	16	17	18
Example	4	0	R	U	Q	A	1	2	A	1	A	6	-	0	A	0	A	0

## Model Type

40RU = Packaged Air Handling Unit with Puron® R-410A Refrigerant

## Type of Coil

Q = DX Coil for Heat Pump Duty

## Refrigerant Options

A = None

## Nominal Tonnage

07 = 6 Ton                      16 = 15 Ton  
 08 = 7.5 Ton                    25 = 20 Ton  
 12 = 10 Ton

## Fan Motor Speed Controller

A = None - Standard  
 T = 2 Speed Fan Controller (VFD) - Staged Air Volume (SAV™)

## Indoor Fan Motor Options - Belt Drive

**NOTE:** See the following two tables for Indoor Fan Motor Options for Single Speed and 2-Speed Motors. Available motors are indicated by a checkmark.

## Coil Options

A = Standard Aluminum Fin / Copper Tube

## Packaging

0 = Standard

## Future Use

A = Standard

## Cabinet Paint

0 = None  
 1 = Painted

## Future Use

A = Standard

## Future Use

0 = Standard

## Revision Number

- = Standard

## Voltage\*

1 = 575/3/60  
 3 = 208/230-1-60 (07 and 08 sizes only)  
 5 = 208/230/3/60  
 6 = 460/3/60

40RUQ

## Notes:

- \* All 40RUQ07 through 16 units with a "6" voltage designation are triple voltage; ie., 208/230/460-3-60. Size 40RUQ16 is also triple voltage in the "6" configuration unless the High Static (Alternate) motor option is used that is discrete 460-3-60. Units that require 2-Speed indoor fan motor must use dedicated voltage models listed. The VFD used is not multi voltage.

C160009

## Single Speed Motors

Position 10	Motor Description	Voltage	Unit Size				
			07	08	12	16	25
1	Std Static, Std Efficient Motor / Std Drive	All	✓	✓	✓	✓	-
4	Std Static, High Efficient Motor / Std Drive	All	-	-	-	-	✓
2	Std Static, Std Efficient Motor / Med Drive	All	✓	✓	✓	✓	-
5	Std Static, High Efficient Motor / Med Drive	All	-	-	-	-	✓
3	High (Alternate) Static, Std Efficient Motor / High Drive	575-3-60	✓	✓	✓	-	-
		208/230-1-60	✓	✓	-	-	-
		208/230-3-60	✓	✓	✓	-	-
		460-3-60	✓	✓	✓	-	-
6	High (Alternate) Static, High Efficient Motor / High Drive	575-3-60	-	-	-	✓	✓
		208/230-3-60	-	-	-	✓	✓
		460-3-60	-	-	-	✓	✓

## 2-Speed Motors

Position 10	Motor Description	Voltage	Unit Size				
			07	08	12	16	25
1	Std Static, Std Efficient Motor / Std Drive	All	✓	✓	✓	✓	-
	Std Static, High Efficient Motor / Std Drive	All	-	-	-	-	✓
2	Std Static, Std Efficient Motor / Med Drive	All	✓	✓	-	✓	-
		All	-	-	-	-	✓
	High (Alternate) Static, Std Efficient Motor / Med Drive	575-3-60	-	-	✓	-	-
		208/230-3-60	-	-	-	-	-
		460-3-60	-	-	-	-	-
		575-3-60	-	-	-	-	-
High (Alternate) Static, High Efficient Motor / Med Drive	208/230-3-60	-	-	✓	-	-	
	460-3-60	-	-	✓	-	-	
3	High (Alternate) Static, Std Efficient Motor / High Drive	575-3-60	✓	✓	✓	-	-
		208/230-3-60	✓	✓	-	-	-
	High (Alternate) Static, High Efficient Motor / High Drive	460-3-60	✓	✓	-	-	-
		575-3-60	-	-	-	✓	✓
		208/230-3-60	-	-	✓	-	-
		460-3-60	-	-	✓	-	-

# PHYSICAL DATA

40RUQ

UNIT 40RUQ*	07	07T	08	12	16	25
<b>NOMINAL CAPACITY (Tons)</b>	6	6	7 <sup>1</sup> / <sub>2</sub>	10	15	20
<b>OPERATING WEIGHT (lb)</b>						
Base Unit with TXV	381	381	385	427	713	720
Plenum	175	175	175	175	225	225
<b>FANS</b>						
Qty...Diam. (in.)	1...15	1...15	1...15	1...15	2...15	2...15
Nominal Airflow (cfm)	2400	2400	3000	4000	6000	8000
Airflow Range (cfm)	1800-3000	1800-3000	2250-3750	3000-5000	4500-7500	6000-10000
Nominal Motor Hp (Standard Motor)*						
208/230-1-60	1.3	1.3	2.4	—	—	—
208/230-3-60 and 460-3-60	2.4	2.4	2.4	2.4	3.7	5.0
575-3-60	1.0	1.0	2.0	2.0	3.0	5.0
Motor Speed (rpm)						
208/230-1-60	1725	1725	1725	—	—	—
208/230-3-60 and 460-3-60	1725	1725	1725	1725	1725	1760
575-3-60	1725	1725	1725	1725	1725	1745
<b>REFRIGERANT</b>	R-410A	R-410A	R-410A	R-410A	R-410A	R-410A
Operating charge (lb) (approx per circuit)†	3.0	3.0	3.0	2.0/2.0	3.0/3.0	3.5/3.5
<b>DIRECT-EXPANSION COIL</b>	Enhanced Copper Tubes, Aluminum Sine-Wave Fins					
Max Working Pressure (psig)	650	650	650	650	650	650
Face Area (sq ft)	8.33	8.33	8.33	10.0	16.56	19.9
No. of Splits	1	1	1	2	2	2
No. of Circuits per Split	15	12	12	9	10	10
Split Type...Percentage	—	—	—	Face...50/50	Face...50/50	Face...50/50
Rows...Fins/in.	3...15	4...15	4...15	4...15	4...15	4...15
<b>PIPING CONNECTIONS,</b>						
Quantity...Size (in.)						
DX Coil — Suction (ODF)	1...1 <sup>1</sup> / <sub>8</sub>	1...1 <sup>1</sup> / <sub>8</sub>	1...1 <sup>1</sup> / <sub>8</sub>	2...1 <sup>1</sup> / <sub>8</sub>	2...1 <sup>1</sup> / <sub>8</sub>	2...1 <sup>1</sup> / <sub>8</sub>
DX Coil — Liquid Refrigerant (ODF)	1...5 <sup>5</sup> / <sub>8</sub>	1...5 <sup>5</sup> / <sub>8</sub>	1...5 <sup>5</sup> / <sub>8</sub>	2...5 <sup>5</sup> / <sub>8</sub>	2...5 <sup>5</sup> / <sub>8</sub>	2...5 <sup>5</sup> / <sub>8</sub>
Steam Coil, In (MPT)	1...2 <sup>1</sup> / <sub>2</sub>	1...2 <sup>1</sup> / <sub>2</sub>	1...2 <sup>1</sup> / <sub>2</sub>	1...2 <sup>1</sup> / <sub>2</sub>	1...2 <sup>1</sup> / <sub>2</sub>	1...2 <sup>1</sup> / <sub>2</sub>
Steam Coil, Out (MPT)	1...1 <sup>1</sup> / <sub>2</sub>	1...1 <sup>1</sup> / <sub>2</sub>	1...1 <sup>1</sup> / <sub>2</sub>	1...1 <sup>1</sup> / <sub>2</sub>	1...1 <sup>1</sup> / <sub>2</sub>	1...1 <sup>1</sup> / <sub>2</sub>
Hot Water Coil, In (MPT)	1...1 <sup>1</sup> / <sub>2</sub>	1...1 <sup>1</sup> / <sub>2</sub>	1...1 <sup>1</sup> / <sub>2</sub>	1...1 <sup>1</sup> / <sub>2</sub>	1...2	1...2
Hot Water Coil, Out (MPT)	1...1 <sup>1</sup> / <sub>2</sub>	1...1 <sup>1</sup> / <sub>2</sub>	1...1 <sup>1</sup> / <sub>2</sub>	1...1 <sup>1</sup> / <sub>2</sub>	1...2	1...2
Condensate (PVC)	1...1 <sup>5</sup> / <sub>8</sub> ODM / 1 <sup>1</sup> / <sub>4</sub> IDF					
<b>FILTERS</b>	Throwaway — Factory Supplied					
Quantity...Size (in.)	4...16 x 24 x 2	4...16 x 24 x 2	4...16 x 24 x 2	4...16 x 24 x 2	4...16 x 20 x 2 4...16 x 24 x 2	4...16 x 20 x 2 4...16 x 24 x 2
Access Location	Either Side	Either Side	Either Side	Either Side	Either Side	Either Side
<b>STEAM COIL‡</b>						
Max Working Pressure (psig at 260° F)	20	20	20	20	20	20
Total Face Area (sq ft)	6.67	6.67	6.67	6.67	13.33	13.33
Rows...Fins/in.	1...9	1...9	1...9	1...9	1...10	1...10
<b>HOT WATER COIL‡</b>						
Max Working Pressure (psig)	150	150	150	150	150	150
Total Face Area (sq ft)	6.67	6.67	6.67	6.67	13.33	13.33
Rows...Fins/in.	2...8.5	2...8.5	2...8.5	2...8.5	2...8.5	2...8.5
Water Volume						
(gal)	8.3	8.3	8.3	8.3	13.9	13.9
(ft <sup>3</sup> )	1.1	1.1	1.1	1.1	1.85	1.85

**LEGEND**

- DX** — Direct Expansion
- TXV** — Thermostatic Expansion Valve
- † Units are shipped without refrigerant charge.
- ‡ Field installed accessory only.
- \* Refer to Alternate Fan Motor Data table for alternate motor data.

## OPTIONS AND ACCESSORIES

ITEM	OPTION*	ACCESSORY†
Alternate Fan Motors	X	
Alternate Drives	X	
Staged Air Volume System	X	
CO <sub>2</sub> Sensors		X
Condensate Drain Trap		X
Discharge Plenum		X
Economizer Ultra LOW LEAK--FDD		X
Economizer Standard Leak		X
Electric Heat		X
Hot Water Heating Coils		X
Overhead Suspension Package		X
Prepainted Units	X	
Programmable Thermostats		X
Return Air Grille		X
Steam Heating Coil		X
Subbase		X
Display Kit for SAV system with VFD		X

\* Factory-installed option.

† Field-installed accessory

### Factory-installed options

**Alternate fan motors and drives** are available to provide the widest possible range of performance.

**Prepainted steel units** are available from the factory for applications that require painted units. Units are painted with American Sterling Gray color.

**Staged Air Volume (SAV) system** saves energy and installation time by utilizing a Variable Frequency Drive (VFD) to automatically adjust the indoor fan motor speed in sequence with the units cooling operation. Per ASHRAE 90.1 2010 standard section 6.4.3.10.b, during the first stage of cooling operation the VFD will adjust the fan motor to provide 2/3rd of the total cfm established for the unit. When a call for the second stage of cooling is required, the VFD will allow the total cfm for the unit established (100%). During the heating mode the VFD will allow total design cfm (100%) operation and during the ventilation mode the VFD will allow operation to 2/3rd of total cfm.

Compared to single speed indoor fan motor systems, Carrier's SAV system can save substantial energy, 25%+\*, versus single speed indoor fan motor systems.

\*Data based on .10 (\$/kWh) in an office application utilizing Carrier's HAP 4.6 simulation software program.

The VFD used in Carrier's SAV system has soft start capabilities to slowly ramp up the speeds, thus eliminating any high inrush air volume during initial start-up. It also has internal over current protection for the fan motor and a field installed display kit that allows adjustment and in depth diagnostics of the VFD.

This SAV system is available on models with 2-stage cooling operation with electrical mechanical controls.

The SAV system is very flexible for initial fan performance set up and adjustment. The standard factory shipped VFD is pre-programmed to automatically stage the fan speed between the first and second stage of cooling. The unit fan performance static pressure and cfm can be easily adjusted using the traditional means of pulley adjustments. The other means to adjust the unit static and cfm performance is to utilize the field installed

Display Kit and adjust the frequency and voltage in the VFD to required performance requirements. In either case, once set up, the VFD will automatically adjust the speed between the cooling stage operations.

### Field-installed accessories

**CO<sub>2</sub> sensors** can be used in conjunction with the economizer accessory to help meet indoor air quality requirements. The sensor signals the economizer to open when the CO<sub>2</sub> level in the space exceeds the set point. A Carrier Comfort System programmable thermostat can be used to override the sensor if the outside-air temperature is too high or too low.

**Condensate drain trap** includes an overflow shutoff switch that can be wired to turn off the unit if the trap becomes plugged. Kit also includes a wire harness that can be connected to an alarm if desired. The transparent trap is designed for easy service and maintenance.

**Discharge plenum** directs the air discharge directly into the occupied space; integral horizontal and vertical louvers enable redirection of airflow. Accessory is available unpainted or painted. Field assembly is required (only applicable for vertical application).

### Economizers - temperature dry bulb controlled -

**Ultra LOW LEAK - EconoMi\$er X** with solid-state W7220 controller, gear-driven, modulating damper, spring return actuator. Supply and outdoor air sensors, and CO<sub>2</sub> sensor compatible, for use in electro mechanical controls only. Also includes return and outside air damper leakage that meets California Title 24 section 140.4 requirements. Controller meets California Title 24 Section 120.2 Fault Detection and Diagnostic (FDD) requirements.

**STANDARD - EconoMi\$er IV** - with gear driven damper blades and W7212 controller (Use --HH--57AC-078 for enthalpy control).

**Electric resistance heat coils** have an open-wire design and are mounted in a rigid frame. Safety cutouts for high temperature conditions are standard. Terminal block for single-point power connection is included.

**Two-row hot water coils** have copper tubes mechanically bonded to aluminum plate fins and non-ferrous headers.

**Overhead suspension package** includes necessary brackets to support units in horizontal ceiling installations.

**Return-air grille** provides a protective barrier over the return-air opening and gives a finished appearance to units installed in the occupied space. Accessory is available unpainted or painted.

**One-row steam coil** has copper tubes and aluminum fins. The Inner Distributing Tube (IDT) design provides uniform temperatures across the coil face. The steam coil has a broad operating pressure range; up to 20 psi (138 kPag) at 260°F (126°C). The IDT steam coils are especially suited to applications where sub-freezing air enters the unit.

**Subbase** provides a stable, raised platform and room for condensate drain trap connection for vertical floor-mounted units. Accessory is available unpainted or painted.

# 40RUQ

## DIMENSIONS

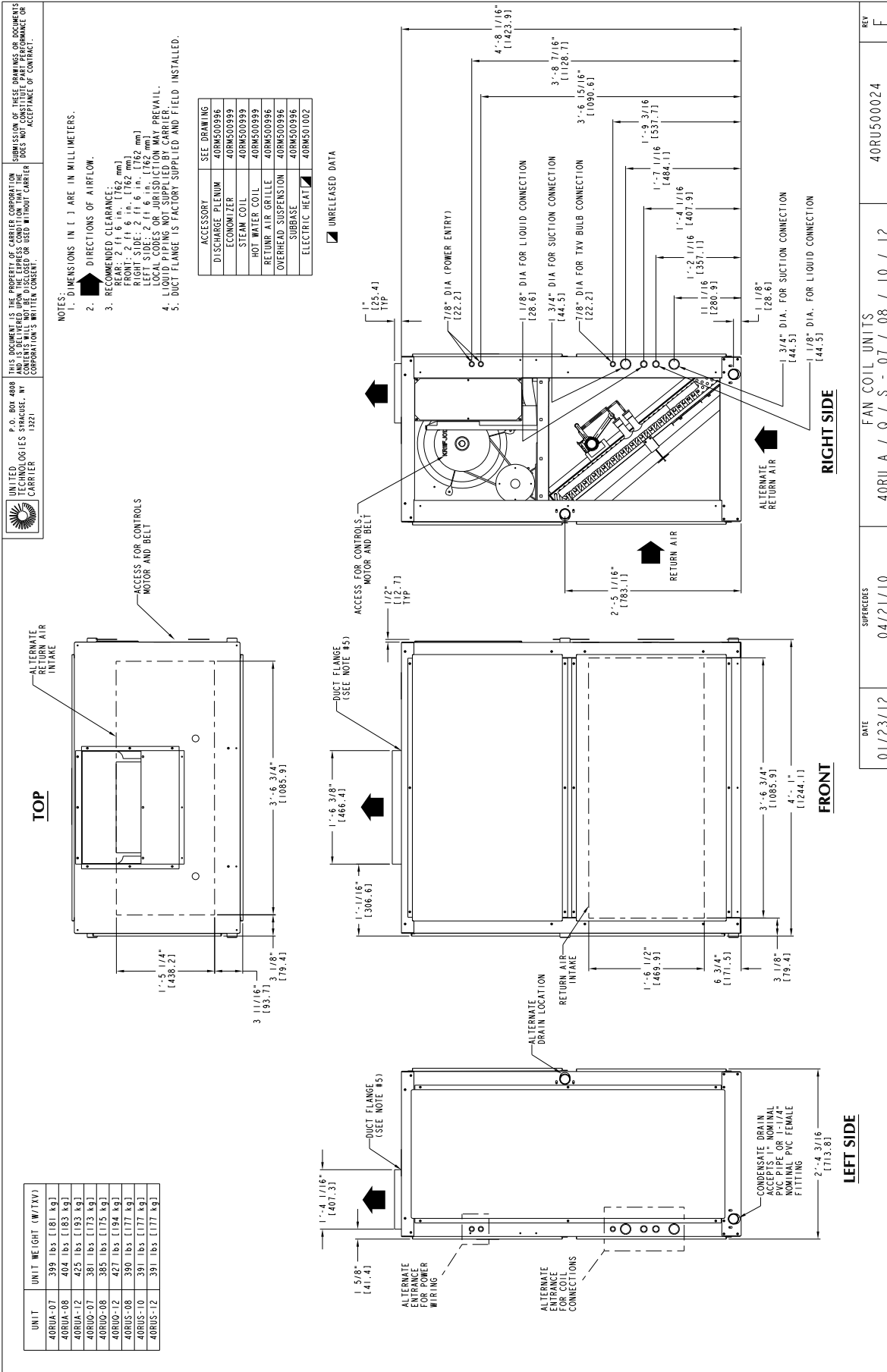

DATE	01/23/12	SUPERSEDES	40RU A / 0 / S - 07 / 08 / 10 / 12	REV	F
					40RU500024

# DIMENSIONS (cont.)

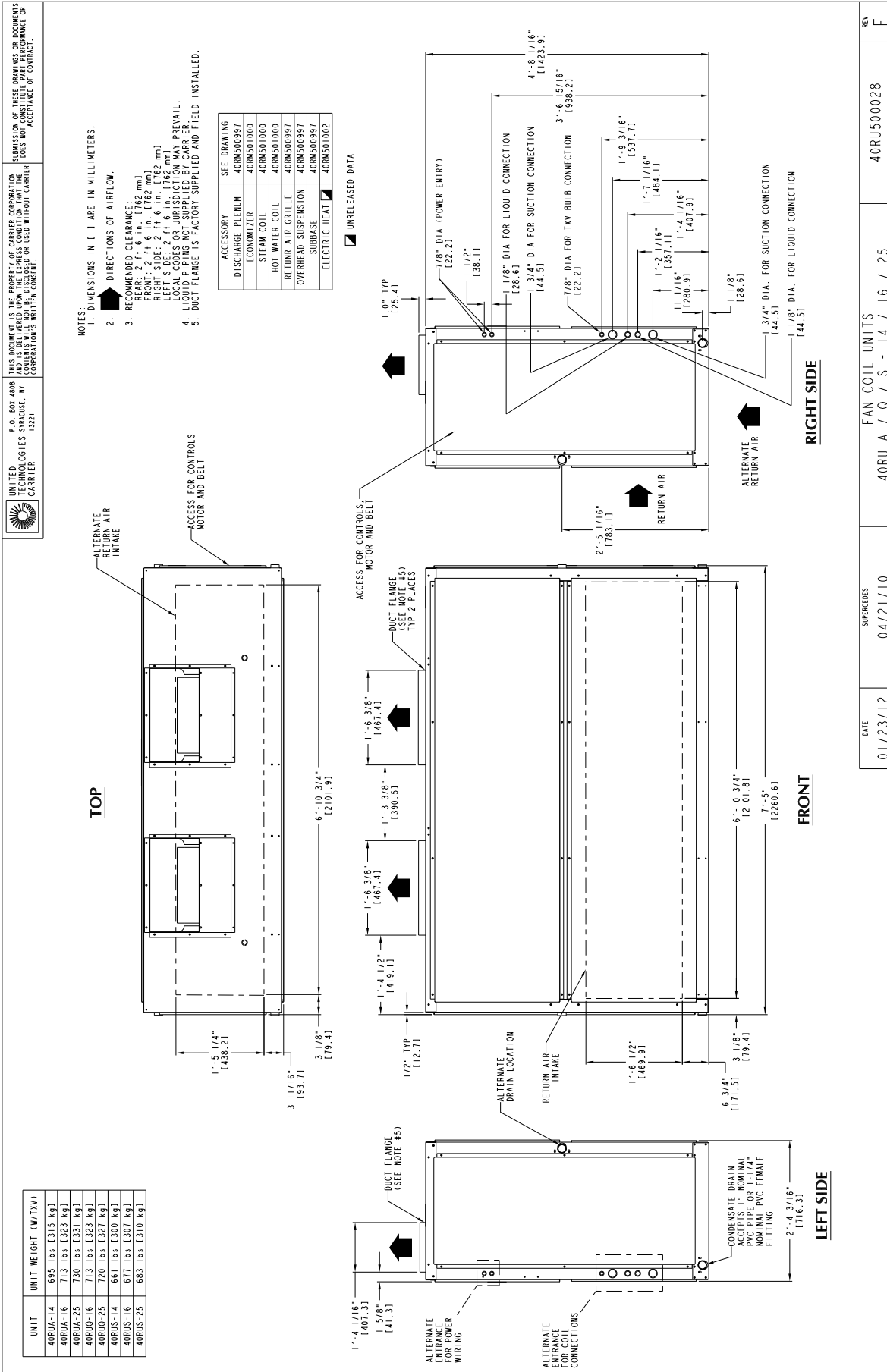

UNIT	DATE	SUPERSEDES	REV
40RUQ*16 & 25	01/23/12	04/21/10	F

**40RUQ**

## DIMENSIONS (cont.)

### CORNER WEIGHTS HORIZONTAL POSITION

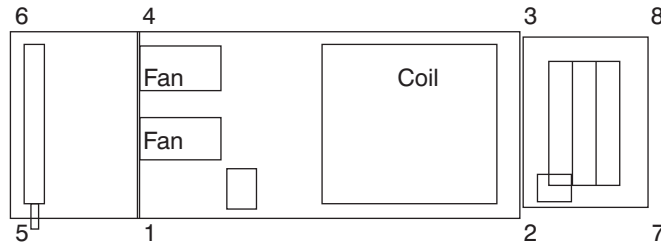

Steam Coil or  
Hot Water Coil

Base Unit Fan Coil

Economizer

C09039

40RUQ UNIT SIZE	UNIT OR ACCESSORY NAME		UNIT OR ACCESSORY WEIGHT lb (kg)	CORNER NUMBER (WEIGHT IN LB)							
				1	2	3	4	5	6	7	8
07, 08, 12	FAN COIL BASE UNIT		394 (178.7)	108.0	104.7	89.4	92.2	—	—	—	—
	STEAM COIL	ADD	137 (62.1)	25.6	0.0	0.0	25.9	42.4	43.0	0.0	0.0
	HOT WATER COIL	ADD	143 (64.9)	26.3	0.0	0.0	26.9	44.3	45.5	0.0	0.0
	ECONOMIZER	ADD	128 (58.5)	0.0	25.5	24.7	0.0	0.0	0.0	39.3	38.1
	ECO + STEAM COIL	ADD	264 (115.2)	25.6	25.5	24.7	25.9	42.4	43.0	39.3	38.1
16, 25	FAN COIL BASE UNIT		684 (310.3)	220.5	174.9	127.8	161.1	—	—	—	—
	STEAM COIL	ADD	239 (108.4)	43.2	0.0	0.0	43.6	75.8	76.5	0.0	0.0
	HOT WATER COIL	ADD	245 (111.1)	44.5	0.0	0.0	44.1	78.7	77.9	0.0	0.0
	ECONOMIZER	ADD	217 (98.4)	0.0	42.7	39.6	0.0	0.0	0.0	70.1	65.1
	ECO + STEAM COIL	ADD	456 (206.8)	43.2	42.7	39.6	43.6	75.8	76.5	70.1	65.1
	ECO + HW COIL	ADD	463 (210.0)	44.5	42.7	39.6	44.1	78.7	77.9	70.1	65.1

40RUQ



## DIMENSIONS (cont.)

### CORNER WEIGHTS VERTICAL POSITION

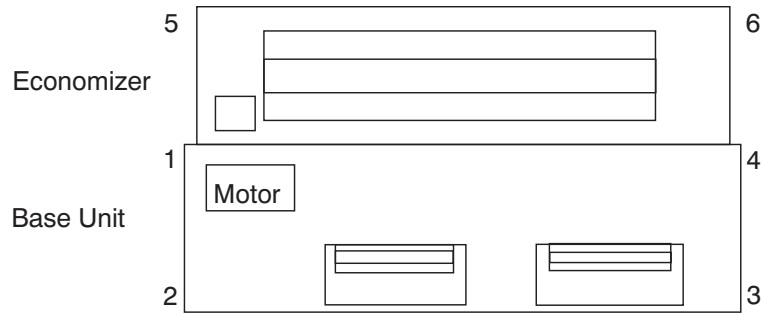

NOTE: Steam, Hot Water & Plenum on top of positions 1,2,3,4

C09040

40RUQ

40RUQ UNIT SIZE	UNIT OR ACCESSORY NAME		UNIT OR ACCESSORY WEIGHT lb (kg)	CORNER NUMBER (WEIGHT IN LB)					
				1	2	3	4	5	6
07, 08, 12	FAN COIL BASE UNIT		394 (178.7)	99.3	113.5	96.8	84.7	—	—
	STEAM COIL	ADD	137 (62.1)	34.5	34.5	34.0	34.0	0.0	0.0
	HOT WATER COIL	ADD	143 (64.9)	36.2	36.2	35.3	35.3	0.0	0.0
	PLENUM	ADD	175 (79.4)	50.8	36.7	36.7	50.8	0.0	0.0
	ECONOMIZER	ADD	128 (58.1)	25.5	0.0	0.0	24.7	39.3	38.1
	ECO + STEAM COIL	ADD	264 (119.7)	59.9	34.5	34.0	58.7	39.3	38.1
	ECO + HW COIL	ADD	271 (122.9)	61.7	36.2	35.3	60.0	39.3	38.1
16, 25	FAN COIL BASE UNIT		684 (310.3)	188.2	207.2	151.4	137.3	—	—
	STEAM COIL	ADD	239 (108.4)	60.0	60.0	59.5	59.5	0.0	0.0
	HOT WATER COIL	ADD	245 (111.1)	61.0	61.0	61.6	61.6	0.0	0.0
	PLENUM	ADD	225 (102.1)	72.5	40.0	40.0	72.5	0.0	0.0
	ECONOMIZER	ADD	217 (98.4)	42.7	0.0	0.0	39.6	70.1	65.1
	ECO + STEAM COIL	ADD	456 (206.8)	102.7	60.0	59.5	99.1	70.1	65.1
	ECO + HW COIL	ADD	463 (210.0)	103.7	61.0	61.6	101.2	70.1	65.1

# DIMENSIONS (cont.)

## OVERHEAD SUSPENSION ACCESSORY

UNIT SIZES 07-12  
(FRONT)

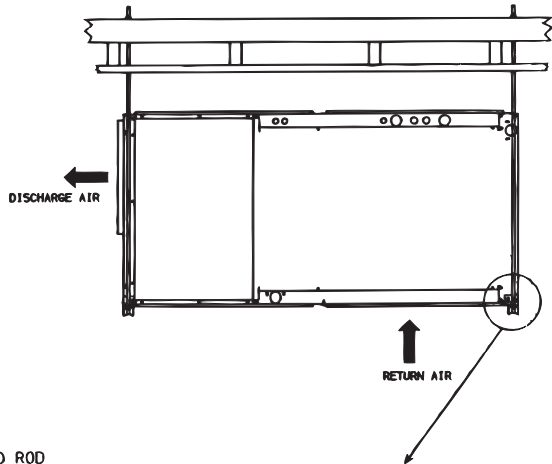
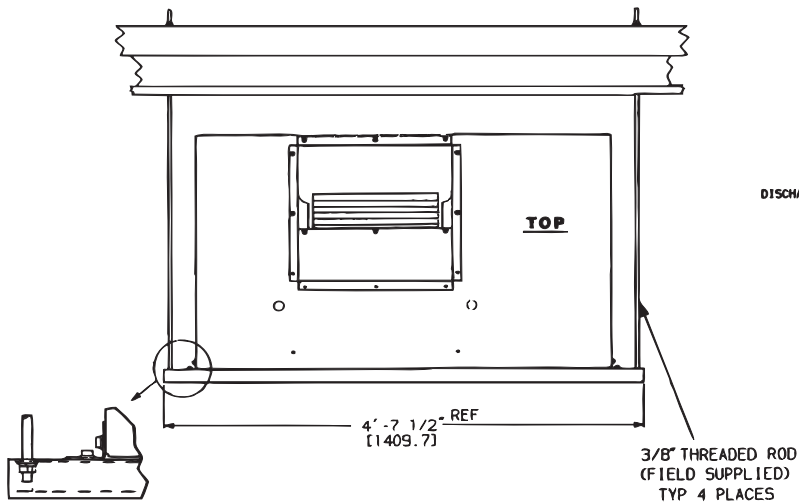

UNIT SIZES 16 & 25  
(FRONT)

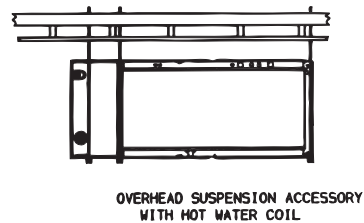
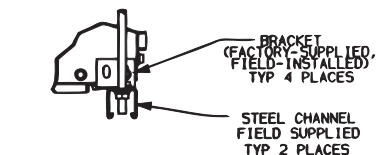
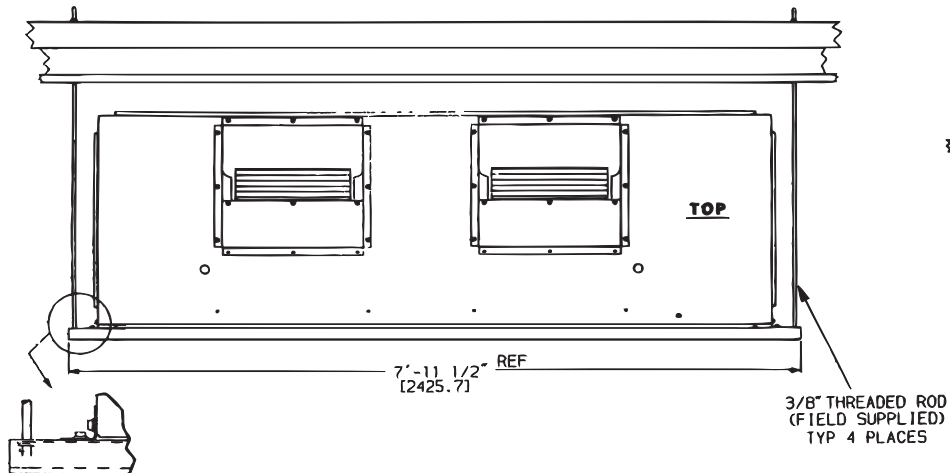

C10877

# DIMENSIONS (cont.)

## PLENUM, RETURN-AIR GRILLE, AND SUBBASE ACCESSORIES

UNIT SIZES 07-12

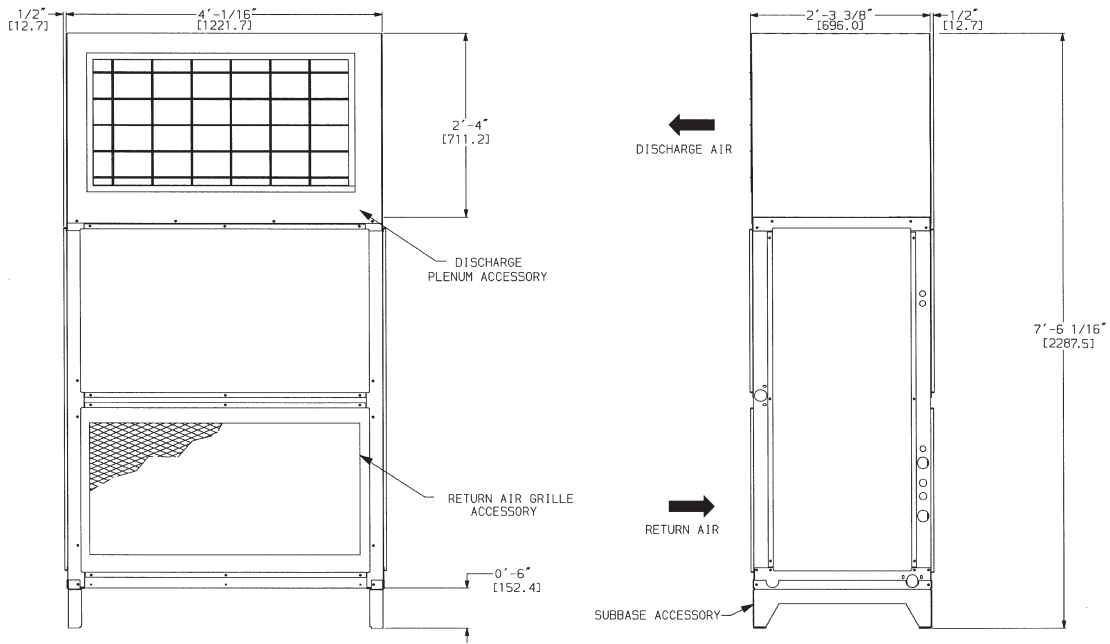

40RUQ

NOTE: Dimensions in [ ] are millimeters.

C10116

## UNIT SIZES 16 & 25 (FRONT)

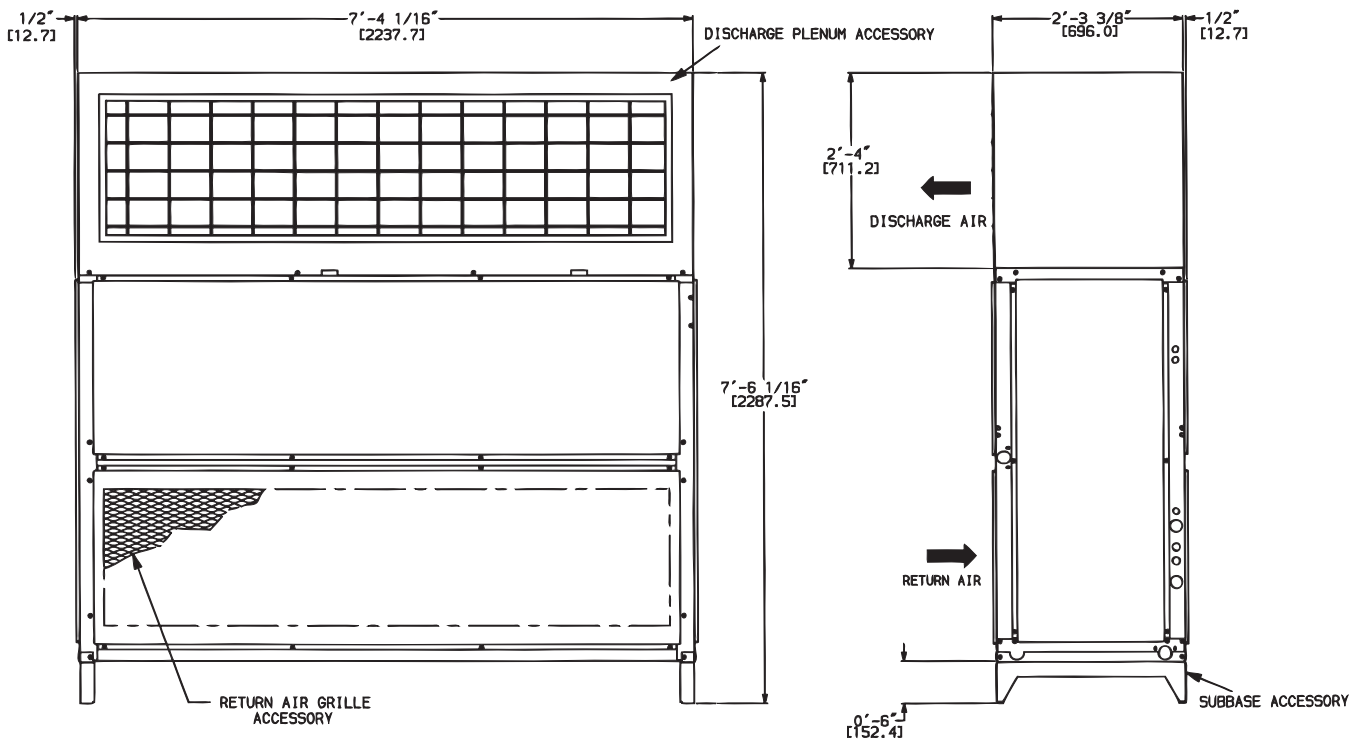

C10878

# DIMENSIONS (cont.)

## HOT WATER AND STEAM COIL ACCESSORIES

UNIT SIZES 07 - 12

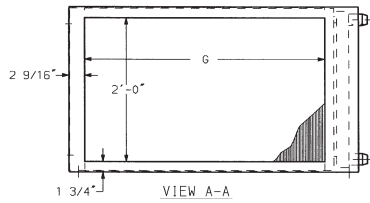
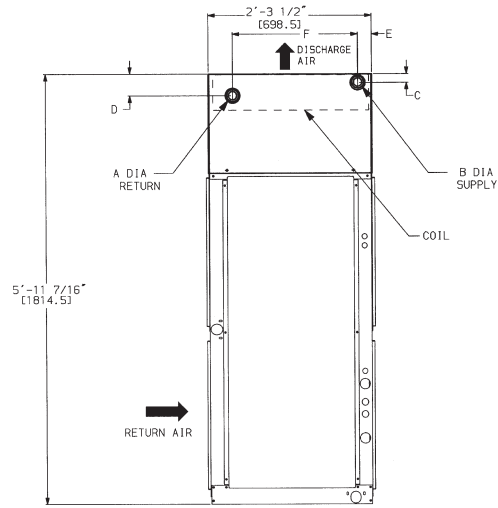
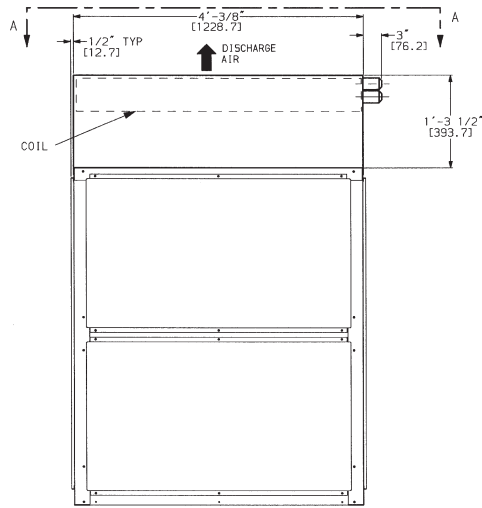

DIMENSION	HOT WATER COIL	STEAM COIL
A	1 1/2" MPT [38.1]	1 1/2" MPT [38.1]
B	1 1/2" MPT [38.1]	2 1/2" MPT [63.5]
C	2 3/8" [60.3]	3 1/8" [79.4]
D	4 7/8" [123.8]	3 1/8" [79.4]
E	2 1/8" [54.0]	4 9/16" [115.8]
F	1'-11 1/4" [590.6]	1'-9" [584.2]
G	3'-4" [1016.0]	3'-4" [1016.0]

NOTE: Dimensions in [ ] are millimeters.

UNIT SIZES 16 & 25

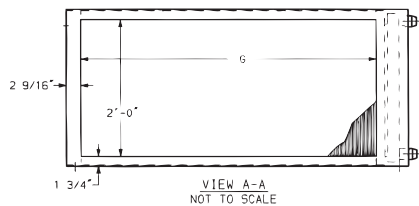
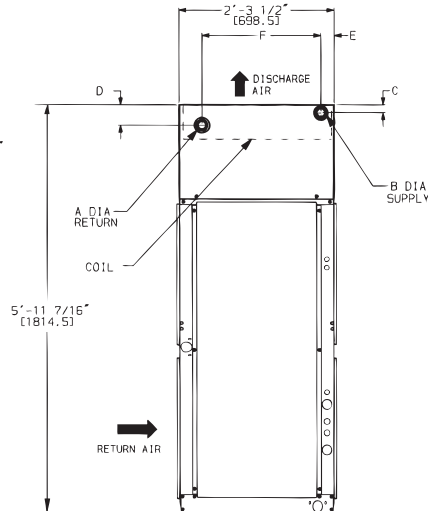
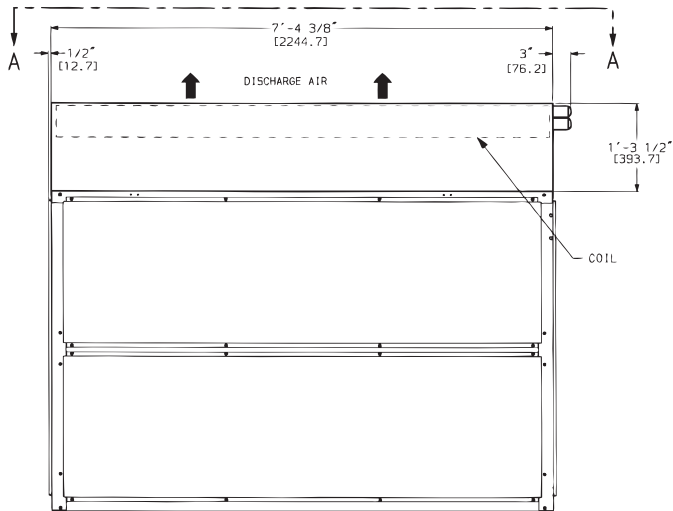

DIMENSION	HOT WATER COIL	STEAM COIL
A	2" MPT [50.8]	1 1/2" MPT [38.1]
B	2" MPT [50.8]	2 1/2" MPT [63.5]
C	2 3/8" [60.3]	3 1/8" [79.4]
D	4 7/8" [123.8]	3 1/8" [79.4]
E	2 1/8" [54.0]	4 9/16" [115.8]
F	1'-11 1/4" [590.6]	1'-9" [584.2]
G	6'-8" [2032.0]	6'-8" [2032.0]

C10117

C10879

40RUQ

# DIMENSIONS (cont.)

## ECONOMIZER ACCESSORY

UNIT SIZES 07-12

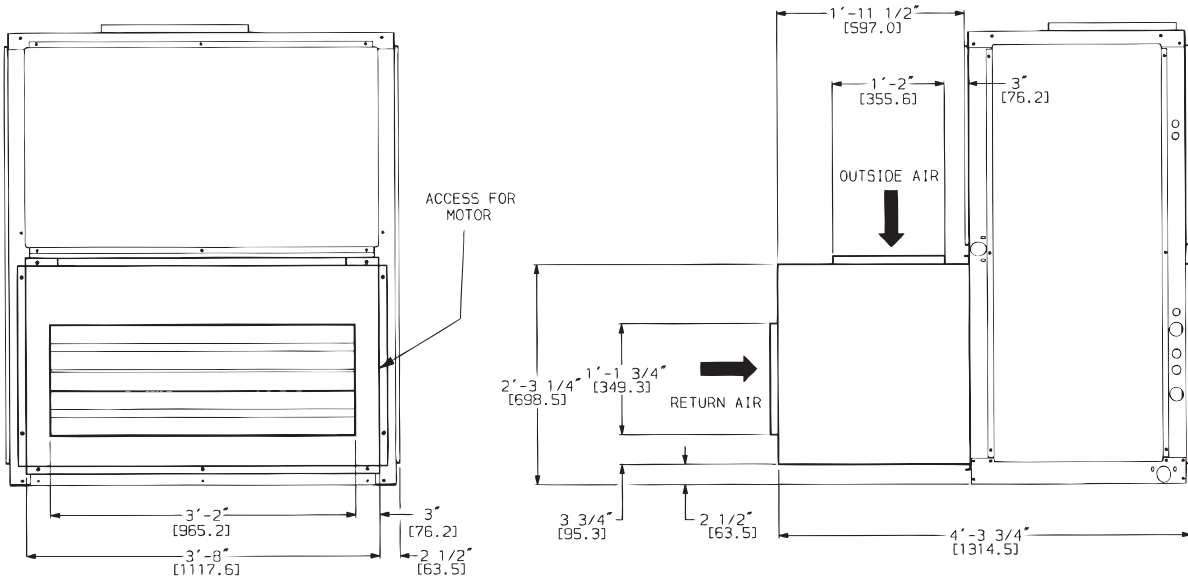

40RUQ

UNIT SIZES 16 & 25

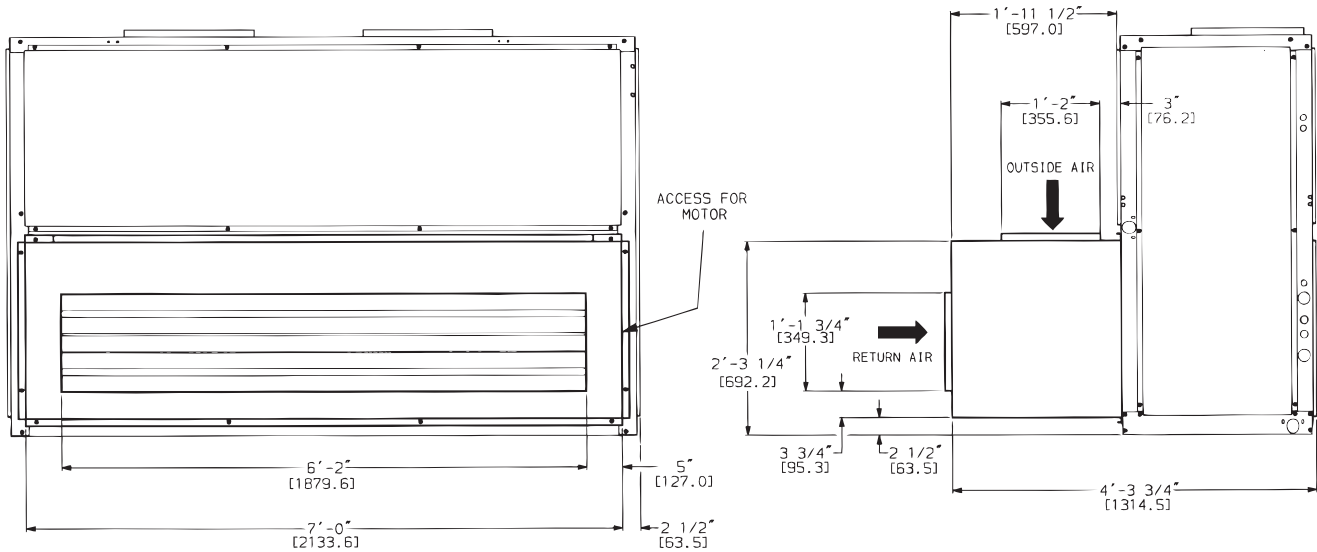

**NOTE:**

1. For horizontal unit applications, economizer can be attached to end of unit opposite duct connections.
2. Dimensions in [ ] are millimeters.

# DIMENSIONS (cont.)

## ELECTRIC HEAT ACCESSORY

### UNIT SIZES 07 - 12

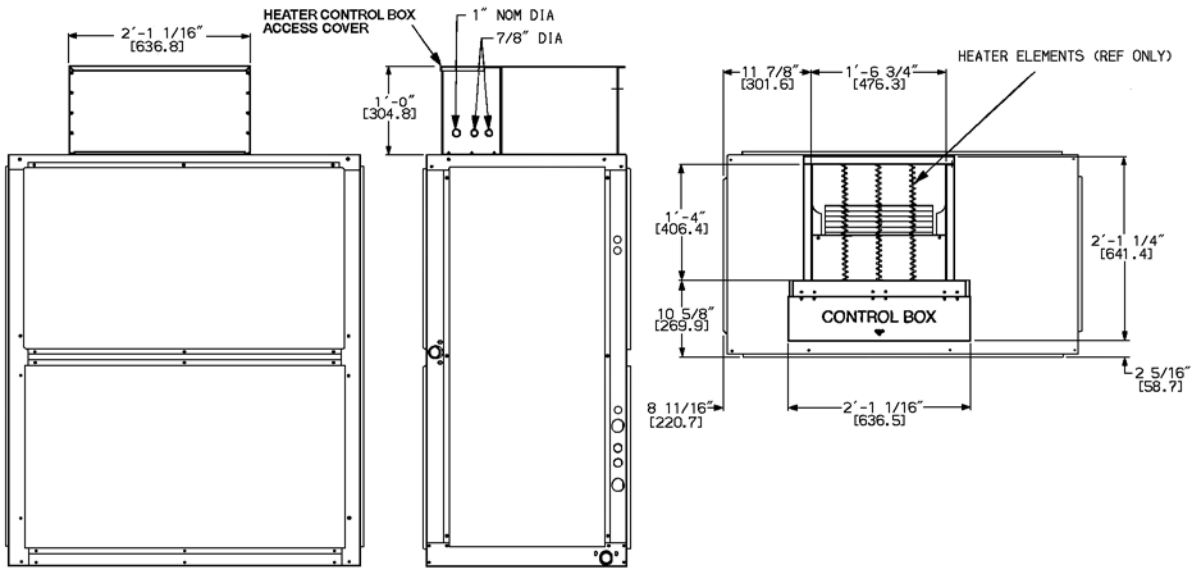

### UNIT SIZE 16 - 25

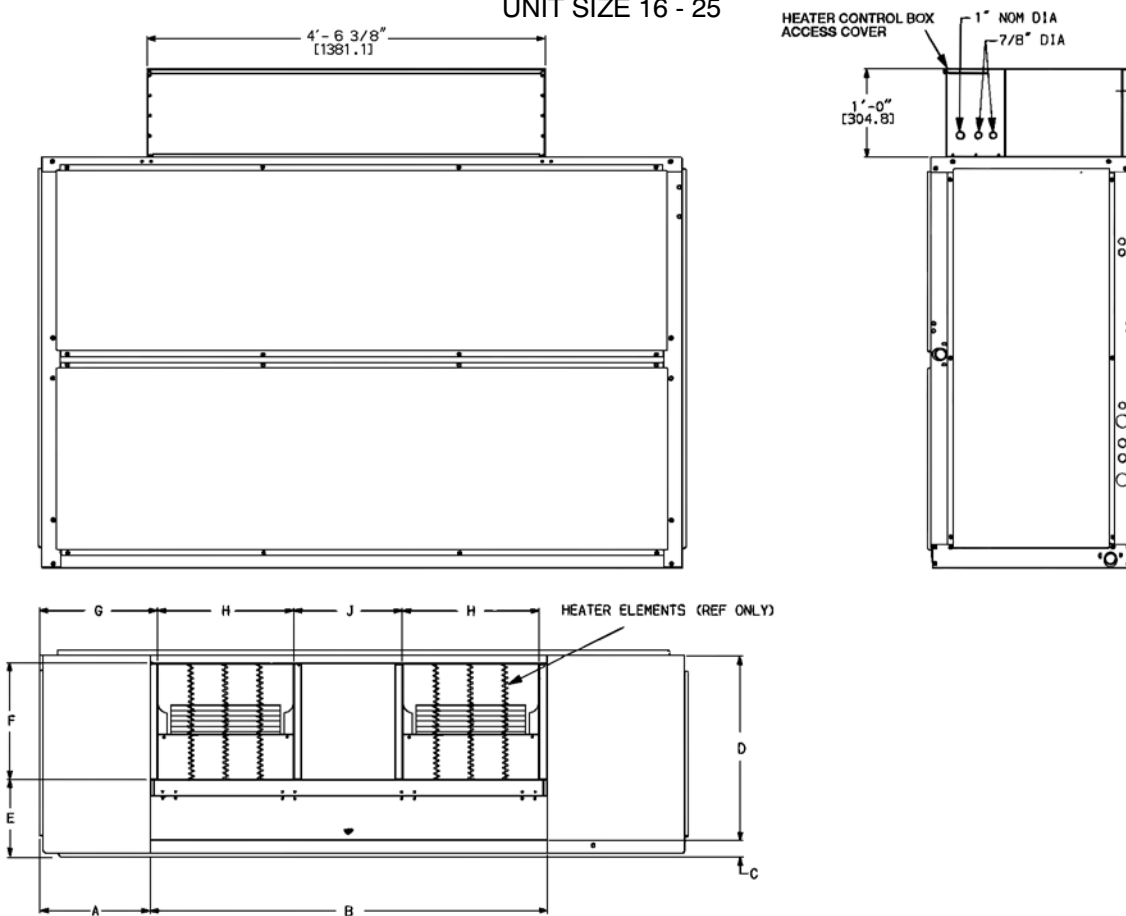

C160008

UNIT SIZE	A	B	C	D	E	F	G	H	J
16 - 25	$1'-3 \frac{1}{4}"$ [387.4]	$4'-6 \frac{3}{8}"$ [1381.1]	$2 \frac{5}{16}"$ [58.7]	$2'-1 \frac{1}{4}"$ [641.4]	$10 \frac{5}{8}"$ [269.9]	$1'-4"$ [406.4]	$1'-4 \frac{5}{16}"$ [414.3]	$1'-6 \frac{3}{4}"$ [476.3]	$1'-7 \frac{7}{8}"$ [327.0]

NOTE: Dimensions in [ ] are millimeters.

40RUQ

# PERFORMANCE DATA

## COOLING ONLY PERFORMANCE

UNIT 40RUQ	EVAPORATOR AIR		COIL REFRIGERANT TEMP °F (°C)									
	AIR FLOW (CFM)	EWB °F (°C)	30 (-1.1)		35 (1.7)		40 (4.4)		45 (7.2)		50 (10)	
			TC	SHC	TC	SHC	TC	SHC	TC	SHC	TC	SHC
07	1800	72 (22.2)	146.4	71.0	132.1	64.3	116.7	57.3	100.0	49.7	81.8	42.0
		67 (19.4)	121.8	74.0	107.6	66.4	92.4	58.9	76.0	51.2	58.3	43.6
		62 (16.7)	99.3	75.5	85.3	67.9	70.2	60.2	54.9	52.4	44.2	44.2
	2400	72 (22.2)	179.3	87.1	161.7	79.1	142.6	70.4	122.0	61.2	99.5	51.8
		67 (19.4)	149.5	91.5	132.2	82.4	113.3	73.2	93.0	63.8	71.0	54.4
		62 (16.7)	122.3	94.2	105.0	84.9	86.2	75.5	67.6	65.7	55.2	55.2
	3000	72 (22.2)	207.4	101.3	186.8	92.0	164.6	81.7	140.6	71.2	114.6	60.4
		67 (19.4)	173.3	106.7	153.1	96.4	131.2	85.8	107.5	75.1	81.9	64.3
		62 (16.7)	142.1	110.8	122.0	100.2	100.0	89.3	78.2	78.2	65.2	65.2
08	2250	72 (22.2)	182.6	88.6	165.5	132.0	146.7	95.2	126.3	64.2	104.0	104.0
		67 (19.4)	152.4	92.7	135.4	83.7	116.9	74.6	96.6	65.2	74.6	55.7
		62 (16.7)	124.9	95.2	107.8	86.0	89.3	76.6	70.2	67.0	56.7	56.7
	3000	72 (22.2)	221.4	107.7	200.6	98.2	177.7	87.8	152.8	76.8	125.7	65.6
		67 (19.4)	185.4	113.8	164.7	103.1	142.1	92.1	117.4	80.9	90.5	69.5
		62 (16.7)	152.4	118.1	131.6	107.2	109.0	95.8	86.2	83.9	70.9	70.9
	3750	72 (22.2)	253.9	124.2	229.9	113.3	203.8	101.4	175.1	89.0	143.9	76.3
		67 (19.4)	213.4	132.1	189.5	120.1	163.4	107.7	135.0	95.0	104.0	82.0
		62 (16.7)	175.8	138.6	151.9	126.1	125.8	113.1	99.4	99.4	83.3	83.3
12	3000	72 (22.2)	221.4	107.7	200.6	163.3	177.7	117.8	152.8	79.1	125.7	125.7
		67 (19.4)	185.4	113.8	164.7	103.1	142.1	92.1	117.4	80.9	90.5	69.5
		62 (16.7)	152.4	118.1	131.6	107.2	109.0	95.8	86.2	83.9	70.9	70.9
	4000	72 (22.2)	263.7	129.4	238.7	117.9	211.6	105.6	181.9	92.8	149.4	79.6
		67 (19.4)	221.7	137.8	197.0	125.4	169.9	112.6	140.3	99.4	108.1	85.9
		62 (16.7)	182.9	144.9	158.0	132.1	130.8	118.5	104.0	104.0	87.2	87.2
	5000	72 (22.2)	298.3	147.4	270.2	134.4	239.6	120.8	205.9	106.6	169.0	91.9
		67 (19.4)	251.7	158.5	223.7	144.8	193.0	130.6	159.4	115.9	122.9	100.7
		62 (16.7)	208.3	168.6	180.1	154.3	149.1	138.5	120.4	120.4	101.5	101.5
16	4500	72 (22.2)	360.1	174.8	326.2	260.8	289.1	187.9	248.7	126.7	204.7	204.7
		67 (19.4)	300.7	183.1	267.0	165.3	230.4	147.2	190.2	128.6	146.8	109.9
		62 (16.7)	246.5	188.2	212.7	170.0	176.0	151.4	138.3	132.3	111.9	111.9
	6000	72 (22.2)	435.7	212.1	394.7	193.6	349.4	172.9	300.3	151.3	246.8	129.2
		67 (19.4)	365.2	224.3	324.1	203.3	279.5	181.6	230.8	159.5	177.6	136.9
		62 (16.7)	300.2	233.1	259.1	211.5	214.3	189.0	169.6	165.5	139.7	139.7
	7500	72 (22.2)	499.1	244.5	451.7	222.9	400.1	199.4	343.7	175.1	282.2	150.0
		67 (19.4)	419.5	260.2	372.5	236.6	321.1	212.2	265.0	187.0	203.9	161.3
		62 (16.7)	345.9	273.1	298.6	248.6	247.0	222.8	195.7	195.7	164.0	164.0
25	6000	72 (22.2)	443.7	215.8	406.1	329.5	363.8	240.8	317.1	164.0	265.2	265.2
		67 (19.4)	374.1	229.7	335.9	210.2	293.5	189.7	246.5	168.3	194.4	146.0
		62 (16.7)	309.8	240.3	271.0	219.9	227.9	198.4	182.4	175.5	149.2	149.2
	8000	72 (22.2)	523.5	257.1	479.7	236.8	430.7	214.8	375.8	191.3	314.5	166.4
		67 (19.4)	443.7	276.5	399.2	254.6	349.3	231.1	293.7	206.4	232.0	180.5
		62 (16.7)	369.1	293.6	323.5	270.3	272.6	245.2	220.6	217.2	184.8	184.8
	10000	72 (22.2)	586.4	289.8	538.6	268.1	484.6	244.5	423.1	218.9	354.4	191.6
		67 (19.4)	499.5	316.4	450.2	292.8	394.6	267.3	332.3	240.1	262.8	211.4
		62 (16.7)	417.2	340.3	366.3	314.9	309.4	286.4	253.1	253.1	215.4	215.4

**40RUQ**

**LEGEND**

- db** — Dry–Bulb Temp (°F)
- Ewb** — Entering Wet–Bulb Temp (°F)
- lwb** — Leaving Wet–Bulb Temp (°F)
- SHC** — Sensible Heat Capacity (1000 Btuh)
- TC** — Total Capacity (1000 Btuh)

**NOTES:**

1. Ratings based on approximately 15°F superheat leaving coil.
2. Direct interpolation is permissible. Do not extrapolate.
3. Dashes indicate coil loading limits are exceeded.
4. Evaporator fan heat not deducted from ratings.

5. Formulas:

$$\text{Leaving db} = \text{entering db} - \frac{\text{sensible heat capacity (Btuh)}}{1.1 \times \text{cfm}}$$

$$\text{Leaving wb} = \text{wet–bulb temperature corresponding to enthalpy of air leaving coil (h}_{lwb}\text{)}$$

$$h_{lwb} = h_{ewb} - \frac{\text{total capacity (Btuh)}}{4.5 \times \text{cfm}}$$

where  $h_{lwb}$  = enthalpy of air entering coil

6. SHC is based on 80°F db temperature of air entering evaporator coil.

# PERFORMANCE DATA (cont.)

## HYDRONIC HEATING CAPACITIES

UNIT	AIRFLOW (Cfm)	1-ROW STEAM*		2-ROW HOT WATER COIL†			
		Cap.	Ldb	Cap.	Ldb	Water Flow (Gpm)	PD
40RUQ07	1,800	146	134	156.0	140	15.6	3.4
	2,400	173	126	183.0	131	18.3	4.3
	3,000	209	123	206.0	124	20.6	5.2
40RUQ08	2,250	168	129	174.0	133	17.4	4.0
	3,000	209	123	206.0	124	20.6	5.2
	3,750	240	117	238.0	118	23.8	6.5
40RUQ12	3,000	209	123	299.0	152	29.9	5.0
	4,000	243	115	275.0	124	27.5	6.6
	5,000	279	111	316.0	119	31.6	8.2
40RUQ16	4,500	402	141	412.0	145	41.2	4.5
	6,000	458	129	471.0	133	47.1	5.5
	7,500	479	118	529.0	125	52.9	6.6
40RUQ25	6,000	458	129	506.0	138	50.6	5.1
	8,000	487	115	584.0	128	58.4	6.3
	10,000	499	105	652.0	120	65.2	7.5

**LEGEND:**

Cap. – Capacity (Btuh in thousands)

Ldb – Leaving Air Dry Bulb Temp (°F)

PD – Pressure Drop (ft water)

\* Based on 5 psig steam, 60° F entering-air temperature. All steam coils are non-freeze type.

† Based on 200° F entering water, 20° F water temperature drop, 60° F entering-air temperature.

**NOTES:**

- Maximum operating limits for heating coils: 20 psig at 260°F.
- Leaving db = ent db (°F) +  $\frac{\text{Capacity (Btuh)}}{1.1 \times \text{cfm}}$
- See Heating Correction Factors table.

## HEATING CORRECTION FACTORS

HOT WATER COIL						
Water Temp Drop °F (°C)	Ent Water Temp °F (°C)	Entering-Air Temp °F (°C)				
		40 (4.4)	50 (10)	60 (15.6)	70 (21.1)	80 (26.7)
10 (-12.2)	140 (60)	0.72	0.64	0.57	0.49	0.41
	160 (71)	0.89	0.81	0.74	0.66	0.58
	180 (82)	1.06	0.98	0.90	0.83	0.75
	200 (93)	1.22	1.15	1.07	1.00	0.92
	220 (104)	1.39	1.32	1.24	1.17	1.09
20 (-6.7)	140 (60)	0.64	0.57	0.49	0.41	0.33
	160 (71)	0.81	0.74	0.66	0.58	0.51
	180 (82)	0.98	0.91	0.83	0.75	0.68
	200 (93)	1.15	1.08	1.00	0.93	0.85
	220 (104)	1.32	1.25	1.17	1.10	1.02
30 (-1.1)	140 (60)	0.56	0.49	0.41	0.33	0.24
	160 (71)	0.74	0.66	0.58	0.51	0.43
	180 (82)	0.91	0.83	0.76	0.68	0.60
	200 (93)	1.08	1.00	0.93	0.85	0.78
	220 (104)	1.25	1.18	1.10	1.03	0.95

STEAM COIL					
Steam Pressure (psig)	Entering-Air Temp °F (°C)				
	40 (4.4)	50 (10)	60 (15.6)	70 (21.1)	80 (26.7)
0	1.06	0.98	0.91	0.85	0.78
2	1.09	1.02	0.95	0.89	0.82
5	1.13	1.06	1.00	0.93	0.87

**NOTE:** Multiply capacity given in the Hydronic Heating Capacities table by the correction factor for conditions at which unit is actually operating. Correct leaving-air temperature using formula in Note 2 of Hydronic Heating Capacities table.



## PERFORMANCE DATA (cont.)

### FAN PERFORMANCE DATA — 40RUQ 0.0-1.2 in. wg ESP — 60 Hz

UNIT	AIRFLOW (Cfm)	EXTERNAL STATIC PRESSURE (in. wg)													
		0.0		0.2		0.4		0.6		0.8		1.0		1.2	
		Rpm	Bhp	Rpm	Bhp	Rpm	Bhp	Rpm	Bhp	Rpm	Bhp	Rpm	Bhp	Rpm	Bhp
40RUQ*07	1,800	<b>419</b>	<b>0.21</b>	471	0.26	564	0.37	649	0.49	<u>727</u>	<u>0.63</u>	<u>797</u>	<u>0.77</u>	<u>862</u>	<u>0.92</u>
	2,100	471	0.31	519	0.37	602	0.49	<u>679</u>	<u>0.62</u>	<u>751</u>	<u>0.77</u>	<u>819</u>	<u>0.92</u>	<u>882</u>	<u>1.09</u>
	2,400	524	0.44	568	0.51	645	0.64	<u>715</u>	<u>0.79</u>	<u>781</u>	<u>0.94</u>	<u>844</u>	<u>1.11</u>	<u>905</u>	<u>1.28</u>
	2,700	578	0.61	619	0.69	<u>690</u>	<u>0.84</u>	<u>755</u>	<u>0.99</u>	<u>816</u>	<u>1.15</u>	<u>875</u>	<u>1.33</u>	<u>932</u>	<u>1.51</u>
	3,000	633	0.81	<u>671</u>	<u>0.90</u>	<u>738</u>	<u>1.07</u>	<u>799</u>	<u>1.24</u>	<u>856</u>	<u>1.41</u>	<u>910</u>	<u>1.60</u>	<u>963</u>	<u>1.79</u>
40RUQ*08	2,250	<b>290</b>	<b>0.10</b>	<b>510</b>	<b>0.39</b>	594	0.51	669	0.65	739	0.79	<u>806</u>	<u>0.95</u>	<u>870</u>	<u>1.12</u>
	2,600	<b>349</b>	<b>0.19</b>	561	0.55	640	0.70	709	0.84	<u>773</u>	<u>1.00</u>	<u>834</u>	<u>1.16</u>	<u>893</u>	<u>1.34</u>
	3,000	579	0.70	621	0.79	695	0.96	<u>759</u>	<u>1.12</u>	<u>818</u>	<u>1.30</u>	<u>874</u>	<u>1.47</u>	<u>928</u>	<u>1.66</u>
	3,400	646	0.99	683	1.09	<u>752</u>	<u>1.29</u>	<u>813</u>	<u>1.48</u>	<u>869</u>	<u>1.67</u>	<u>920</u>	<u>1.86</u>	<u>970</u>	<u>2.06</u>
	3,750	705	1.31	739	1.42	<u>804</u>	<u>1.63</u>	<u>862</u>	<u>1.85</u>	<u>915</u>	<u>2.05</u>	<u>964</u>	<u>2.26</u>	<u>1011</u>	<u>2.48</u>
40RUQ*12	3,000	<b>421</b>	<b>0.35</b>	<b>592</b>	<b>0.73</b>	670	0.90	737	1.06	<u>797</u>	<u>1.23</u>	<u>854</u>	<u>1.41</u>	<u>908</u>	<u>1.59</u>
	3,500	<b>626</b>	<b>0.98</b>	<b>664</b>	<b>1.08</b>	735	1.28	798	1.48	<u>855</u>	<u>1.67</u>	<u>908</u>	<u>1.87</u>	<u>958</u>	<u>2.07</u>
	4,000	706	1.42	738	1.54	803	1.77 <sup>†</sup>	862	2.00 <sup>†</sup>	<u>917</u>	<u>2.23</u>	<u>967</u>	<u>2.45</u>	<u>1014</u>	<u>2.67</u>
	4,500	786	1.99 <sup>†</sup>	815	2.12 <sup>†</sup>	<u>873</u>	<u>2.39</u>	<u>929</u>	<u>2.65</u>	<u>980</u>	<u>2.90</u>	<u>1028</u>	<u>3.16</u>	<u>1073</u>	<u>3.41</u>
	5,000	<u>867</u>	<u>2.70</u>	<u>893</u>	<u>2.84</u>	<u>946</u>	<u>3.14</u>	<u>997</u>	<u>3.43</u>	<u>1046</u>	<u>3.72</u>	<u>1092</u>	<u>4.00</u>	<u>1135</u>	<u>4.28</u>
40RUQ*16	4,500	<b>437</b>	<b>0.61</b>	<b>483</b>	<b>0.72</b>	576	1.01	660	1.35	<u>732</u>	<u>1.69</u>	<u>797</u>	<u>2.03</u>	<u>856</u>	<u>2.38</u>
	5,300	<b>499</b>	<b>0.95</b>	538	1.07	617	1.37	696	1.74	<u>767</u>	<u>2.13</u>	<u>830</u>	<u>2.53</u>	<u>888</u>	<u>2.94</u>
	6,000	<b>555</b>	<b>1.34</b>	590	1.48	659	1.79	<u>730</u>	<u>2.17</u>	<u>798</u>	<u>2.59</u>	<u>860</u>	<u>3.04</u>	<u>918</u>	<u>3.49</u>
	6,800	620	1.91	651	2.06	712	2.39	<u>774</u>	<u>2.78</u>	<u>836</u>	<u>3.22</u>	<u>896</u>	<u>3.71</u>	<u>952</u>	<u>4.21</u>
	7,500	677	2.52	706	2.69	<u>761</u>	<u>3.04</u>	<u>817</u>	<u>3.44</u>	<u>873</u>	<u>3.89</u>	<u>929</u>	<u>4.39</u>	<u>984</u>	<u>4.93</u>
40RUQ*25	6,000	<b>542</b>	<b>1.29</b>	<b>577</b>	<b>1.42</b>	<b>646</b>	<b>1.72</b>	716	2.09	785	2.51	849	2.95	<u>907</u>	<u>3.40</u>
	7,000	<b>620</b>	<b>1.99</b>	<b>652</b>	<b>2.15</b>	711	2.48	771	2.85	831	3.28	<u>890</u>	<u>3.76</u>	<u>947</u>	<u>4.27</u>
	8,000	700	2.92	728	3.10	781	3.46	833	3.85	<u>885</u>	<u>4.29</u>	<u>938</u>	<u>4.78</u>	<u>990</u>	<u>5.32</u>
	9,000	781	4.10	806	4.30	854	4.71	<u>900</u>	<u>5.13</u>	<u>946</u>	<u>5.58</u>	<u>993</u>	<u>6.08</u>	<u>1039</u>	<u>6.62</u>
	10,000	862	5.56	<u>885</u>	<u>5.79</u>	<u>929</u>	<u>6.24</u>	<u>971</u>	<u>6.70</u>	<u>1012</u>	<u>7.18</u>	<u>1054</u>	<u>7.69</u>	<u>1096</u>	<u>8.24</u>

40RUQ

**LEGEND**

Bhp — Brake Horsepower Input to Fan

ESP — External Static Pressure

**Bold** indicates field-supplied drive is required.

Plain type indicates standard motor and standard drive.

Underline indicates a different motor and drive combination other than the standard motor and standard drive combination is required.

Refer to fan motor and drive tables to complete selection.

<sup>†</sup> — With two speed fan, these operating points require different motor and drive combination.

# PERFORMANCE DATA (cont.)

## FAN PERFORMANCE DATA — 40RUQ 1.4-2.4 in. wg ESP — 60 Hz

**40RUQ**

UNIT	AIRFLOW (Cfm)	EXTERNAL STATIC PRESSURE (in. wg)											
		1.4		1.6		1.8		2.0		2.2		2.4	
		Rpm	Bhp	Rpm	Bhp	Rpm	Bhp	Rpm	Bhp	Rpm	Bhp	Rpm	Bhp
<b>40RUQ*07</b>	<b>1,800</b>	<u>921</u>	<u>1.07</u>	<u>975</u>	<u>1.23</u>	<u>1026</u>	<u>1.39</u>	<u>1074</u>	<u>1.55</u>	<b>1120</b>	<b>1.72</b>	<b>1164</b>	<b>1.90</b>
	<b>2,100</b>	<u>942</u>	<u>1.26</u>	<u>997</u>	<u>1.43</u>	<u>1048</u>	<u>1.61</u>	<b>1097</b>	<b>1.79</b>	<b>1143</b>	<b>1.97</b>	<b>1186</b>	<b>2.16</b>
	<b>2,400</b>	<u>963</u>	<u>1.47</u>	<u>1017</u>	<u>1.66</u>	<u>1069</u>	<u>1.85</u>	<b>1118</b>	<b>2.05</b>	<b>1164</b>	<b>2.25</b>	—	—
	<b>2,700</b>	<u>987</u>	<u>1.71</u>	<u>1039</u>	<u>1.91</u>	<b>1090</b>	<b>2.12</b>	<b>1138</b>	<b>2.33</b>	<b>1185</b>	<b>2.55</b>	—	—
	<b>3,000</b>	<u>1015</u>	<u>1.99</u>	<u>1065</u>	<u>2.20</u>	<b>1113</b>	<b>2.42</b>	<b>1161</b>	<b>2.65</b>	—	—	—	—
<b>40RUQ*08</b>	<b>2,250</b>	<u>930</u>	<u>1.29</u>	<u>986</u>	<u>1.47</u>	<u>1039</u>	<u>1.65</u>	<u>1089</u>	<u>1.84</u>	<u>1136</u>	<u>2.03</u>	<u>1181</u>	<u>2.22</u>
	<b>2,600</b>	<u>950</u>	<u>1.53</u>	<u>1005</u>	<u>1.72</u>	<u>1057</u>	<u>1.92</u>	<u>1107</u>	<u>2.13</u>	<u>1154</u>	<u>2.33</u>	—	—
	<b>3,000</b>	<u>980</u>	<u>1.86</u>	<u>1031</u>	<u>2.06</u>	<u>1081</u>	<u>2.27</u>	<u>1129</u>	<u>2.49</u>	<u>1175</u>	<u>2.72</u>	—	—
	<b>3,400</b>	<u>1018</u>	<u>2.26</u>	<u>1065</u>	<u>2.48</u>	<u>1111</u>	<u>2.70</u>	<u>1156</u>	<u>2.93</u>	—	—	—	—
	<b>3,750</b>	<u>1057</u>	<u>2.69</u>	<u>1101</u>	<u>2.92</u>	<u>1144</u>	<u>3.15</u>	<u>1186</u>	<u>3.39</u>	—	—	—	—
<b>40RUQ*12</b>	<b>3,000</b>	<u>961</u>	<u>1.78</u>	<u>1012</u>	<u>1.98</u>	<u>1062</u>	<u>2.19</u>	<u>1111</u>	<u>2.41</u>	<u>1158</u>	<u>2.64</u>	—	—
	<b>3,500</b>	<u>1005</u>	<u>2.27</u>	<u>1052</u>	<u>2.49</u>	<u>1098</u>	<u>2.71</u>	<u>1142</u>	<u>2.94</u>	<u>1186</u>	<u>3.18</u>	—	—
	<b>4,000</b>	<u>1058</u>	<u>2.90</u>	<u>1101</u>	<u>3.13</u>	<u>1143</u>	<u>3.36</u>	<u>1184</u>	<u>3.60</u>	—	—	—	—
	<b>4,500</b>	<u>1116</u>	<u>3.66</u>	<u>1157</u>	<u>3.91</u>	<u>1196</u>	<u>4.16</u>	—	—	—	—	—	—
	<b>5,000</b>	<u>1176</u>	<u>4.56</u>	—	—	—	—	—	—	—	—	—	—
<b>40RUQ*16</b>	<b>4,500</b>	<u>912</u>	<u>2.75</u>	<u>967</u>	<u>3.12</u>	<u>1019</u>	<u>3.52</u>	<u>1070</u>	<u>3.92</u>	<u>1120</u>	<u>4.35</u>	<u>1168</u>	<u>4.79</u>
	<b>5,300</b>	<u>942</u>	<u>3.34</u>	<u>992</u>	<u>3.76</u>	<u>1041</u>	<u>4.18</u>	<u>1088</u>	<u>4.61</u>	<u>1134</u>	<u>5.06</u>	<u>1179</u>	<u>5.52</u>
	<b>6,000</b>	<u>971</u>	<u>3.95</u>	<u>1020</u>	<u>4.40</u>	<u>1067</u>	<u>4.86</u>	<u>1112</u>	<u>5.33</u>	<u>1156</u>	<u>5.81</u>	<u>1198</u>	<u>6.29</u>
	<b>6,800</b>	<u>1005</u>	<u>4.72</u>	<u>1054</u>	<u>5.23</u>	<u>1101</u>	<u>5.75</u>	<u>1145</u>	<u>6.27</u>	<u>1187</u>	<u>6.79</u>	—	—
	<b>7,500</b>	<u>1036</u>	<u>5.48</u>	<u>1084</u>	<u>6.04</u>	<u>1131</u>	<u>6.61</u>	<u>1174</u>	<u>7.17</u>	—	—	—	—
<b>40RUQ*25</b>	<b>6,000</b>	<u>961</u>	<u>3.86</u>	<u>1011</u>	<u>4.31</u>	<u>1058</u>	<u>4.77</u>	<u>1104</u>	<u>5.24</u>	<u>1147</u>	<u>5.71</u>	—	—
	<b>7,000</b>	<u>1000</u>	<u>4.79</u>	<u>1050</u>	<u>5.32</u>	<u>1097</u>	<u>5.85</u>	<u>1142</u>	<u>6.38</u>	<u>1184</u>	<u>6.91</u>	—	—
	<b>8,000</b>	<u>1041</u>	<u>5.88</u>	<u>1090</u>	<u>6.47</u>	<u>1137</u>	<u>7.07</u>	<u>1181</u>	<u>7.67</u>	—	—	—	—
	<b>9,000</b>	<u>1086</u>	<u>7.21</u>	<u>1133</u>	<u>7.82</u>	<u>1178</u>	<u>8.47</u>	—	—	—	—	—	—
	<b>10,000</b>	<u>1138</u>	<u>8.83</u>	<u>1180</u>	<u>9.46</u>	—	—	—	—	—	—	—	—

**LEGEND**

Bhp — Brake Horsepower Input to Fan

ESP — External Static Pressure

**Bold** indicates field-supplied drive is required.

Plain type indicates standard motor and standard drive.

Underline indicates a different motor and drive combination other than the standard motor and standard drive combination is required. Refer to fan motor and drive tables to complete selection.

### DUCT SOUND POWER LEVELS (Lw)

MODEL	SIZE	CFM	dB(A)	OCTAVE BAND CENTER FREQUENCY (Hz)						
				63	125	250	500	1000	2000	4000
40RUQ	07	2,400	86.3	93.2	89.2	85.2	84.2	80.2	78.2	74.2
	08	3,000	88.3	95.3	91.3	87.3	86.3	82.3	80.3	76.3
	12	4,000	92.0	99.0	95.0	91.0	90.0	86.0	84.0	80.0
	16	6,000	92.9	99.2	95.2	91.2	92.2	86.2	84.2	80.2
	25	8,000	96.4	102.6	98.6	94.6	95.6	89.2	87.6	839.6

**LEGEND:**

ASHRAE — American Society of Heating, Refrigerating and Air Conditioning, Inc.

HVAC — Heating, Ventilation and Air Conditioning

**NOTES:**

- The above estimated sound power levels are based upon the ASHRAE calculation approach from the ASHRAE HVAC Systems and Applications handbook.
- Since this data is calculated, these sound power levels may be different than the actual sound power levels.
- The acoustic center of the unit is located at the geometric center of the unit.

## PERFORMANCE DATA (cont.)

### FACTORY-SUPPLIED FILTER PRESSURE DROP

SIZE	UNIT	AIRFLOW (Cfm)	PRESSURE DROP (in. wg)
07	40RUQ	1,800	0.05
		2,400	0.08
		3,000	0.11
08	40RUQ	2,250	0.07
		3,000	0.11
		3,750	0.15
12	40RUQ	3,000	0.11
		4,000	0.17
		5,000	0.23
16	40RUQ	4,500	0.08
		6,000	0.12
		7,500	0.17
25	40RUQ	6,000	0.12
		8,000	0.19
		10,000	0.26

40RUQ

### ACCESSORY PLENUM AIR THROW DATA (Ft)

UNIT	AIRFLOW (Cfm)	VANE DEFLECTION		
		Straight	21 <sup>1</sup> / <sub>2</sub> °	45°
40RUQ07	2,400	39	33	24
40RUQ08	3,000	45	38	28
40RUQ12	4,000	55	46	33
40RUQ16	6,000	50	43	31
40RUQ25	8,000	60	51	37

**NOTE:** Throw distances shown are for 75 fpm terminal velocity. Use the following multipliers to determine throw values for other terminal velocities.

TERMINAL VELOCITY (Fpm)	THROW FACTOR
50	X 1.50
100	X 0.75
150	X 0.50

### ACCESSORY PRESSURE DROP (in. wg)

UNIT	AIRFLOW (Cfm)	DISCHARGE PLENUM	RETURN AIR GRILLE	Hot Water	Steam	Electric	ECONOMIZER
40RUQ07	1,800	0.06	0.01	0.10	0.10	0.04	0.05
	2,400	0.10	0.01	0.16	0.16	0.06	0.07
	3,000	0.14	0.02	0.23	0.23	0.10	0.09
40RUQ08	2,250	0.09	0.01	0.15	0.15	0.06	0.06
	3,000	0.14	0.02	0.23	0.23	0.10	0.09
	3,750	0.21	0.03	0.35	0.35	0.15	0.15
40RUQ12	3,000	0.14	0.02	0.23	0.23	0.10	0.09
	4,000	0.22	0.04	0.37	0.37	0.17	0.17
	5,000	0.32	0.06	0.53	0.53	0.26	0.28
40RUQ16	4,500	0.10	0.01	0.15	0.15	0.06	0.06
	6,000	0.16	0.02	0.23	0.23	0.10	0.09
	7,500	0.23	0.03	0.33	0.33	0.15	0.15
40RUQ25	6,000	0.16	0.02	0.23	0.23	0.10	0.09
	8,000	0.26	0.04	0.37	0.37	0.17	0.17
	10,000	0.37	0.06	0.53	0.53	0.26	0.28

# ELECTRICAL DATA

**Table 1 – Electrical Data, Standard Motors with Factory-Installed Single Speed Fan Option**

UNIT	V-PH-Hz†	VOLTAGE LIMITS	FAN MOTOR		POWER SUPPLY	
			Hp (kW)	FLA	Minimum Circuit Amps	MAX FUSE or HACR BRKR
40RUQ*07	208/230-1-60	187-253	1.3 (0.97)	6.60	9.00	15
	208/230-3-60	187-253	2.4 (1.79)	5.2	7.0	15
	460-3-60	414-506	2.4 (1.79)	2.6	4.0	15
	575-3-60	518-632	1.0 (0.75)	1.40	2.0	15
40RUQ*08	208/230-1-60	187-253	2.4 (1.79)	11.00	13.80	20
	208/230-3-60	187-253	2.4 (1.79)	5.2	7.0	15
	460-3-60	414-506	2.4 (1.79)	2.6	4.0	15
	575-3-60	518-632	2.0 (1.49)	2.40	3.0	15
40RUQ*12	208/230-3-60	187-253	2.4 (1.79)	5.2	7.0	15
	460-3-60	414-506	2.4 (1.79)	2.6	4.0	15
	575-3-60	518-632	2.0 (1.49)	2.40	3.0	15
40RUQ*16	208/230-3-60	187-253	3.7 (2.76)	10.2	13.0	20
	460-3-60	414-506	3.7 (2.76)	4.8	6.0	15
	575-3-60	518-632	3.0 (2.24)	3.80	5.0	15
40RUQ*25	208/230-3-60	187-253	5.0 (3.73)	18.0	23.0	40
	460-3-60	414-506	5.0 (3.73)	9.1	12.0	20
	575-3-60	518-632	5.0 (3.73)	8.0	10.0	15

See: "Legend and Notes for Tables 1 – 4" on page 22.

**Table 2 – Electrical Data, Alternate Motors with Factory-Installed Single Speed Fan Option**

UNIT	V-PH-Hz†	VOLTAGE LIMITS	FAN MOTOR		POWER SUPPLY	
			Hp (kW)	FLA	Minimum Circuit Amps	MAX FUSE or HACR BRKR
40RUQ*07	208/230-1-60	187-253	2.4 (1.79)	11.00	13.80	20
	208/230-3-60	187-253	2.9 (2.16)	7.5	10.0	15
	460-36-0	414-506	2.9 (2.16)	3.4	5.0	15
	575-3-60	518-632	2.0 (1.49)	2.40	3.0	15
40RUQ*08	208/230-1-60	187-253	2.4 (1.79)	11.00	13.80	15
	208/230-3-60	187-253	2.9 (2.16)	7.5	10.0	15
	460-3-60	414-506	2.9 (2.16)	3.4	5.0	15
	575-3-60	518-632	3.0 (2.24)	3.80	5.0	15
40RUQ*12	208/230-3-60	187-253	3.7 (2.76)	10.2	13.0	20
	460-3-60	414-506	3.7 (2.76)	4.8	6.0	15
	575-3-60	518-632	3.0 (2.24)	3.80	5.0	15
40RUQ*16	208/230-3-60	187-253	5.0 (3.73)	18.0	23.0	40
	460-3-60	414-506	5.0 (3.73)	9.1	12.0	20
	575-3-60	518-632	5.0 (3.73)	8.0	10.0	15
40RUQ*25	208/230-3-60	187-253	7.5 (5.59)	23.5	30.0	50
	460-3-60	414-506	7.5 (5.59)	15.0	19.0	30
	575-3-60	518-632	7.5 (5.59)	10.0	13.0	20

See: "Legend and Notes for Tables 1 – 4" on page 22.

**40RUQ**

## ELECTRICAL DATA (cont.)

**Table 3 – Electrical Data, Standard Motors with Factory-Installed 2-Speed Fan Option**

UNIT	V-PH-Hz†	VOLTAGE LIMITS	FAN MOTOR		POWER SUPPLY	
			Hp (kW)	FLA	Minimum Circuit Amps	MAX FUSE or HACR BRKR
40RUQ*07	208/230-3-60	187-253	2.4 (1.79)	7.1	9.0	15
	460-3-60	414-506	2.4 (1.79)	3.8	5.0	15
	575-3-60	518-632	2.4 (1.79)	3.5	5.0	15
40RUQ*08	208/230-3-60	187-253	2.4 (1.79)	7.1	9.0	15
	460-3-60	414-506	2.4 (1.79)	3.8	5.0	15
	575-3-60	518-632	2.4 (1.79)	3.5	5.0	15
40RUQ*12 Units Produced On or Prior to 02/28/2016	208/230-3-60	187-253	2.4 (1.79)	7.1	9.0	15
	460-3-60	414-506	2.4 (1.79)	3.8	5.0	15
	575-3-60	518-632	2.4 (1.79)	3.5	5.0	15
40RUQ*12 Units Produced On or After 02/29/2016	208/230-3-60	187-253	1.7 (1.27)	5.8	8.0	15
	460-3-60	414-506	1.7 (1.27)	2.9	4.0	15
	575-3-60	518-632	1.7 (1.27)	2.8	4.0	15
40RUQ*16	208/230-3-60	187-253	3.7 (2.76)	10.8	14.0	20
	460-3-60	414-506	3.7 (2.76)	4.9	7.0	15
	575-3-60	518-632	3.7 (2.76)	4.5	6.0	15
40RUQ*25	208/230-3-60	187-253	5.0 (3.73)	18.0	23.0	40
	460-3-60	414-506	5.0 (3.73)	9.1	12.0	20
	575-3-60	518-632	5.0 (3.73)	8.0	10.0	15

See: "Legend and Notes for Tables 1 – 4" on page 22.

40RUQ

**Table 4 – Electrical Data, Alternate Motors with Factory-Installed 2-Speed Fan Option**

UNIT	V-PH-Hz†	VOLTAGE LIMITS	FAN MOTOR		POWER SUPPLY	
			Hp (kW)	FLA	Minimum Circuit Amps	MAX FUSE or HACR BRKR
40RUQ*07	208/230-3-60	187-253	3.7 (2.76)	10.8	14.0	20
	460-36-0	414-506	3.7 (2.76)	4.9	7.0	15
	575-3-60	518-632	3.7 (2.76)	4.5	6.0	15
40RUQ*08	208/230-3-60	187-253	3.7 (2.76)	10.8	14.0	20
	460-3-60	414-506	3.7 (2.76)	4.9	7.0	15
	575-3-60	518-632	3.7 (2.76)	4.5	6.0	15
40RUQ*12 Units Produced On or Prior to 02/28/2016	208/230-3-60	187-253	3.7 (2.76)	10.8	14.0	20
	460-3-60	414-506	3.7 (2.76)	4.9	7.0	15
	575-3-60	518-632	3.7 (2.76)	4.5	6.0	15
40RUQ*12 Units Produced On or After 02/29/2016	208/230-3-60	187-253	3.7 (2.76)	10.6	14.0	20
	460-3-60	414-506	3.7 (2.76)	5.3	7.0	15
	575-3-60	518-632	3.7 (2.76)	4.5	6.0	15
40RUQ*16	208/230-3-60	187-253	5.0 (3.73)	18.0	23.0	40
	460-3-60	414-506	5.0 (3.73)	9.1	12.0	20
	575-3-60	518-632	5.0 (3.73)	8.0	10.0	15
40RUQ*25	208/230-3-60	187-253	7.5 (5.59)	23.5	30.0	50
	460-3-60	414-506	7.5 (5.59)	15.0	19.0	30
	575-3-60	518-632	7.5 (5.59)	10.0	13.0	20

See: "Legend and Notes for Tables 1 – 4" on page 22.

# ELECTRICAL DATA (cont.)

## Legend and Notes for Tables 1 – 41

### LEGEND:

FLA – Full Load Amps

MOCP – MAX FUSE or HACR BRKR

† Motors are designed for satisfactory operation within 10% of normal voltage shown. Voltages should not exceed the limits shown in the Voltage Limits column.

### NOTES:

4. Minimum circuit amps (MCA) and fuse or HACR breaker values are calculated in accordance with The NEC, Article 440.
5. Motor FLA values are established in accordance with Underwriters' Laboratories (UL), Standard 1995.
6. **Unbalanced 3-Phase Supply Voltage**  
Never operate a motor where a phase imbalance in supply voltage is greater than 2%. Use the formula in the example (see column to the right) to determine the percentage of voltage imbalance.
7. **Installation with Accessory Electric Heaters**  
Size the Field Power Wiring between the heater TB1 and the 40RUQ indoor fan motor per NEC Article 430-28 (1) or (2) (depends on length of conduit between heater enclosure and 40RUQ power entry location). Install wires in field-installed conduit.



Example: Supply voltage is 230-3-60

$$\% \text{ Voltage Imbalance} = 100 \times \frac{\text{max voltage deviation from average voltage}}{\text{average voltage}}$$



AB = 393 v

BC = 403 v

AC = 396 v

$$\begin{aligned} \text{Average Voltage} &= \frac{(393 + 403 + 396)}{3} = \frac{1192}{3} \\ &= 397 \end{aligned}$$

Determine maximum deviation from average voltage.

(AB) 397 – 393 = 4 v

(BC) 403 – 397 = 6 v

(AC) 397 – 396 = 1 v

Maximum deviation is 4 v.

Determine percent of voltage imbalance.

$$\begin{aligned} \% \text{ Voltage Imbalance} &= 100 \times \frac{6}{397} \\ &= 1.5\% \end{aligned}$$

This amount of phase imbalance is satisfactory as it is below the maximum allowable 2%.

**IMPORTANT:** If the supply voltage phase imbalance is more than 2%, contact your local electric utility company immediately.

# ELECTRICAL DATA (cont.)

**Table 5 – Electric Heater Data - Single Speed Motor**

HEATER PART NO. CAELHEAT	SIZE	V-PH-Hz	FAN MOTOR			ELECTRIC HEATER(S)					MCA*	MOCP*
						Nom. Cap. (kW)	Actual Capacity (kW)			FLA		
			Hp	kW	FLA		Stage 1	Stage 2	Total			
001A00	40RUQ 07-12	208-3-60	1.3†	0.97	6.6	5.0	3.8	-	3.76	10.4	21.3	25
			2.4†	1.79	11.0	5.0	3.8	-	3.76	10.4	26.8	35
			2.4	1.79	5.2	5.0	3.8	-	3.76	10.4	19.5	20
			2.9	2.16	7.5	5.0	3.8	-	3.76	10.4	22.4	25
		240-3-60	1.3†	0.97	6.6	5.0	5.0	-	5.0	12.0	23.3	25
			2.4†	1.79	11.0	5.0	5.0	-	5.0	12.0	28.8	35
			2.4	1.79	5.2	5.0	5.0	-	5.0	12.0	21.5	25
			2.9	2.16	7.5	5.0	5.0	-	5.0	12.0	24.4	25
002A00	480-3-60	2.4	1.79	2.6	5.0	5.0	-	5.0	6.0	10.8	15	
		2.9	2.16	3.4	5.0	5.0	-	5.0	6.0	11.8	15	
		3.7	2.76	4.8	5.0	5.0	-	5.0	6.0	13.5	15	
003A00	575-3-60	1.0	0.75	1.4	5.0	5.0	-	5.0	5.0	8.0	15	
		2.0	1.49	2.4	5.0	5.0	-	5.0	5.0	9.3	15	
		3.0	2.24	3.8	5.0	5.0	-	5.0	5.0	11.0	15	
004A00	40RUQ 07-12	208-3-60	1.3†	0.97	6.6	10.0	7.5	-	7.51	20.8	34.3	35
			2.4†	1.79	11.0	10.0	7.5	-	7.51	20.8	39.8	40
			2.4	1.79	5.2	10.0	7.5	-	7.51	20.8	32.6	35
			2.9	2.16	7.5	10.0	7.5	-	7.51	20.8	35.4	40
		240-3-60	1.3†	0.97	6.6	10.0	10.0	-	10.0	24.1	38.3	40
			2.4†	1.79	11.0	10.0	10.0	-	10.0	24.1	43.8	50
			2.4	1.79	5.2	10.0	10.0	-	10.0	24.1	36.6	40
			2.9	2.16	7.5	10.0	10.0	-	10.0	24.1	39.4	40
005A00	480-3-60	2.4	1.79	2.6	10.0	10.0	-	10.0	12.0	18.3	20	
		2.9	2.16	3.4	10.0	10.0	-	10.0	12.0	19.3	20	
		3.7	2.76	4.8	10.0	10.0	-	10.0	12.0	21.0	25	
006A00	575-3-60	1.0	0.75	1.4	10.0	10.0	-	10.0	10.0	14.3	15	
		2.0	1.49	2.4	10.0	10.0	-	10.0	10.0	15.6	20	
		3.0	2.24	3.8	10.0	10.0	-	10.0	10.0	17.3	20	
007A00	40RUQ 07-12	208-3-60	1.3†	0.97	6.6	15.0	11.3	-	11.27	31.3	47.4	50
			2.4†	1.79	11.0	15.0	11.3	-	11.27	31.3	52.9	60
			2.4	1.79	5.2	15.0	11.3	-	11.27	31.3	45.6	50
			2.9	2.16	7.5	15.0	11.3	-	11.27	31.3	48.5	50
		240-3-60	1.3†	0.97	6.6	15.0	15.0	-	15.0	36.1	53.4	60
			2.4†	1.79	11.0	15.0	15.0	-	15.0	36.1	58.9	60
			2.4	1.79	5.2	15.0	15.0	-	15.0	36.1	51.6	60
			2.9	2.16	7.5	15.0	15.0	-	15.0	36.1	54.5	60
			3.7	2.76	10.2	15.0	15.0	-	15.0	36.1	57.9	60

**40RUQ**

See: "Legend and Notes for Tables 5 and 6" on page 29.

# ELECTRICAL DATA (cont.)

**Table 5 - Electric Heater Data - Single Speed Motor (cont)**

**40RUQ**

HEATER PART NO. CAELHEAT	SIZE	V-PH-Hz	FAN MOTOR			ELECTRIC HEATER(S)					MCA*	MOCP*	
						Nom. Cap. (kW)	Actual Capacity (kW)			FLA			
			Hp	kW	FLA		Stage 1	Stage 2	Total				
008A00	40RUQ 07-12	480-3-60	2.4	1.79	2.6	15.0	15.0	-	15.0	18.0	25.8	30	
			2.9	2.16	3.4	15.0	15.0	-	15.0	18.0	26.8	30	
			3.7	2.76	4.8	15.0	15.0	-	15.0	18.0	28.6	30	
009A00		575-3-60	1.0	0.75	1.4	15.0	15.0	-	15.0	15.1	20.6	25	
			2.0	1.49	2.4	15.0	15.0	-	15.0	15.1	21.8	25	
			3.0	2.24	3.8	15.0	15.0	-	15.0	15.1	23.6	25	
010A00		40RUQ 07-12	208-3-60	1.3†	0.97	6.6	25.0	11.3	7.5	18.8	52.1	73.4	80
				2.4†	1.79	11.0	25.0	11.3	7.5	18.8	52.1	78.9	80
				2.4	1.79	5.2	25.0	11.3	7.5	18.8	52.1	71.7	80
	2.9			2.16	7.5	25.0	11.3	7.5	18.8	52.1	74.5	80	
	240-3-60		3.7	2.76	10.2	25.0	11.3	7.5	18.8	52.1	77.9	80	
			1.3†	0.97	6.6	25.0	15.0	10.0	25.0	60.1	83.4	90	
			2.4†	1.79	11.0	25.0	15.0	10.0	25.0	60.1	88.9	90	
			2.4	1.79	5.2	25.0	15.0	10.0	25.0	60.1	81.7	90	
	480-3-60		2.9	2.16	7.5	25.0	15.0	10.0	25.0	60.1	84.6	90	
			3.7	2.76	10.2	25.0	15.0	10.0	25.0	60.1	87.9	90	
			2.4	1.79	2.6	25.0	15.0	10.0	25.0	30.1	40.8	50	
			2.9	2.16	3.4	25.0	15.0	10.0	25.0	30.1	41.8	50	
011A00	480-3-60	3.7	2.76	4.8	25.0	15.0	10.0	25.0	30.1	43.6	50		
		012A00	575-3-60	1.0	0.75	1.4	25.0	15.0	10.0	25.0	25.1	33.1	35
				2.0	1.49	2.4	25.0	15.0	10.0	25.0	25.1	34.4	35
3.0	2.24			3.8	25.0	15.0	10.0	25.0	25.1	36.1	40		
013A00	40RUQ 08, 12	208-3-60	2.4†	1.79	11.0	35.0	15.0	11.3	26.3	73.0	105.0	110	
			2.4	1.79	5.2	35.0	15.0	11.3	26.3	73.0	97.7	100	
			2.9	2.16	7.5	35.0	15.0	11.3	26.3	73.0	100.6	110	
			3.7	2.76	10.2	35.0	15.0	11.3	26.3	73.0	104.0	110	
		240-3-60	2.4†	1.79	11.0	35.0	20.0	15.0	35.0	84.2	119.0	125	
			2.4	1.79	5.2	35.0	20.0	15.0	35.0	84.2	111.7	125	
			2.9	2.16	7.5	35.0	20.0	15.0	35.0	84.2	114.6	125	
480-3-60	3.7	2.76	10.2	35.0	20.0	15.0	35.0	84.2	118.0	125			
	014A00	480-3-60	2.4	1.79	2.6	35.0	20.0	15.0	35.0	42.1	55.9	60	
			2.9	2.16	3.4	35.0	20.0	15.0	35.0	42.1	56.9	60	
3.7			2.76	4.8	35.0	20.0	15.0	35.0	42.1	58.6	60		
015A00	575-3-60	2.0	1.49	2.4	35.0	20.0	15.0	35.0	35.1	46.9	50		
		3.0	2.24	3.8	35.0	20.0	15.0	35.0	35.1	48.7	50		

See: "Legend and Notes for Tables 5 and 6" on page 29.



# ELECTRICAL DATA (cont.)

**Table 5 - Electric Heater Data - Single Speed Motor (cont)**

HEATER PART NO. CAELHEAT	SIZE	V-PH-Hz	FAN MOTOR			ELECTRIC HEATER(S)					MCA*	MOCP*	
						Nom. Cap. (kW)	Actual Capacity (kW)			FLA			
			Hp	kW	FLA		Stage 1	Stage 2	Total				
016A00	40RUQ	16, 25	208-3-60	2.9	2.16	7.5	10.0	7.5	-	7.5	20.8	35.4	40
				3.7	2.76	10.2	10.0	7.5	-	7.5	20.8	38.8	40
				5.0	3.73	18.0	10.0	7.5	-	7.5	20.8	48.6	60
			7.5	5.59	23.5	10.0	7.5	-	7.5	20.8	55.4	70	
			240-3-60	2.9	2.16	7.5	10.0	10.0	-	10.0	24.1	39.4	40
				3.7	2.76	10.2	10.0	10.0	-	10.0	24.1	42.8	50
5.0	3.73	18.0		10.0	10.0	-	10.0	24.1	52.6	60			
7.5	5.59	23.5	10.0	10.0	-	10.0	24.1	59.4	70				
017A00	480-3-60	2.9	2.16	3.4	10.0	10.0	-	10.0	12.0	19.3	20		
		3.7	2.76	4.8	10.0	10.0	-	10.0	12.0	21.0	25		
		5.0	3.73	9.1	10.0	10.0	-	10.0	12.0	26.4	30		
7.5	5.59	15.0	10.0	10.0	-	10.0	12.0	33.8	40				
018A00	575-3-60	3.0	2.24	3.8	10.0	10.0	-	10.0	10.0	17.3	20		
		5.0	3.73	8.0	10.0	10.0	-	10.0	10.0	22.6	25		
		7.5	5.59	10.0	10.0	10.0	-	10.0	10.0	25.1	30		
019A00	40RUQ	16, 25	208-3-60	2.9	2.16	7.5	20.0	14.9	-	15.0	41.7	61.5	70
				3.7	2.76	10.2	20.0	14.9	-	15.0	41.7	64.9	70
				5.0	3.73	18.0	20.0	14.9	-	15.0	41.7	74.6	80
			7.5	5.59	23.5	20.0	14.9	-	15.0	41.7	81.5	90	
			240-3-60	2.9	2.16	7.5	20.0	19.9	-	20.0	48.1	69.5	70
				3.7	2.76	10.2	20.0	19.9	-	20.0	48.1	72.9	80
5.0	3.73	18.0		20.0	19.9	-	20.0	48.1	82.6	90			
7.5	5.59	23.5	20.0	19.9	-	20.0	48.1	89.5	100				
020A00	480-3-60	2.9	2.16	3.4	20.0	20.0	-	20.0	24.1	34.3	35		
		3.7	2.76	4.8	20.0	20.0	-	20.0	24.1	36.1	40		
		5.0	3.73	9.1	20.0	20.0	-	20.0	24.1	41.4	50		
		7.5	5.59	15.0	20.0	20.0	-	20.0	24.1	48.8	50		
021A00	575-3-60	3.0	2.24	3.8	20.0	20.0	-	20.0	20.1	29.9	30		
		5.0	3.73	8.0	20.0	20.0	-	20.0	20.1	35.1	40		
		7.5	5.59	10.0	20.0	20.0	-	20.0	20.1	37.6	40		
022A00	40RUQ	16, 25	208-3-60	2.9	2.16	7.5	30.0	15.0	7.5	22.5	62.5	87.5	90
				3.7	2.76	10.2	30.0	15.0	7.5	22.5	62.5	90.9	100
				5.0	3.73	18.0	30.0	15.0	7.5	22.5	62.5	100.7	110
			7.5	5.59	23.5	30.0	15.0	7.5	22.5	62.5	107.5	110	
			240-3-60	2.9	2.16	7.5	30.0	20.0	10.0	30.0	72.2	99.6	100
				3.7	2.76	10.2	30.0	20.0	10.0	30.0	72.2	103.0	110
5.0	3.73	18.0		30.0	20.0	10.0	30.0	72.2	112.7	125			
7.5	5.59	23.5	30.0	20.0	10.0	30.0	72.2	119.6	125				
023A00	480-3-60	2.9	2.16	3.4	30.0	20.0	10.0	30.0	36.1	49.4	50		
		3.7	2.76	4.8	30.0	20.0	10.0	30.0	36.1	51.1	60		
		5.0	3.73	9.1	30.0	20.0	10.0	30.0	36.1	56.5	60		
		7.5	5.59	15.0	30.0	20.0	10.0	30.0	36.1	63.9	70		
024A00	575-3-60	3.0	2.24	3.8	30.0	20.0	10.0	30.0	30.1	42.4	50		
		5.0	3.73	8.0	30.0	20.0	10.0	30.0	30.1	47.7	50		
		7.5	5.59	10.0	30.0	20.0	10.0	30.0	30.1	50.2	60		
025A00	40RUQ	16, 25	208-3-60	3.7	2.76	10.2	50.0	22.6	15.0	37.6	104.3	143.1	150
				5.0	3.73	18.0	50.0	22.6	15.0	37.6	104.3	152.8	175
				7.5	5.59	23.5	50.0	22.6	15.0	37.6	104.3	159.7	175
			240-3-60	3.7	2.76	10.2	50.0	30.0	20.0	50.0	120.3	163.1	175
				5.0	3.73	18.0	50.0	30.0	20.0	50.0	120.3	172.9	175
				7.5	5.59	23.5	50.0	30.0	20.0	50.0	120.3	179.7	200
026A00	480-3-60	3.7	2.76	4.8	50.0	30.0	20.0	50.0	60.1	81.2	90		
		5.0	3.73	9.1	50.0	30.0	20.0	50.0	60.1	86.6	90		
		7.5	5.59	15.0	50.0	30.0	20.0	50.0	60.1	93.9	100		
027A00	575-3-60	3.0	2.24	3.8	50.0	30.0	20.0	50.0	50.2	67.5	70		
		5.0	3.73	8.0	50.0	30.0	20.0	50.0	50.2	72.8	80		
		7.5	5.59	10.0	50.0	30.0	20.0	50.0	50.2	75.3	80		

**40RUQ**

See: "Legend and Notes for Tables 5 and 6" on page 29.

# ELECTRICAL DATA (cont.)

Table 6 – Electric Heater Data - 2-Speed Motor

**40RUQ**

HEATER-PART NO.-CAELHEAT	SIZE	V-Ph-Hz	FAN MOTOR			ELECTRIC HEATER(S)					MCA*	MOCPS*
						Nom. Cap. (kW)	Actual Capacity			FLA		
			HP	kW	FLA		Stage 1	Stage 2	Total			
001A00	40RUQ 07-12	208-3-60	1.7	1.27	5.8	5.0	3.8	-	3.8	10.4	20.3	25
			2.4	1.79	7.1	5.0	3.8	-	3.8	10.4	21.9	25
			3.7	2.76	10.8	5.0	3.8	-	3.8	10.4	26.5	30
			3.7**	2.76	10.6	5.0	3.8	-	3.8	10.4	26.3	30
		240-3-60	1.7	1.27	5.6	5.0	5.0	-	5.0	12.0	22.0	25
			2.4	1.79	7.1	5.0	5.0	-	5.0	12.0	23.9	25
			3.7	2.76	10.8	5.0	5.0	-	5.0	12.0	28.5	35
			3.7**	2.76	10.6	5.0	5.0	-	5.0	12.0	28.3	35
002A00	480-3-60	1.7	1.27	2.9	5.0	5.0	-	5.0	6.0	11.1	15	
		2.4	1.79	3.8	5.0	5.0	-	5.0	6.0	12.3	15	
		3.7	2.76	4.9	5.0	5.0	-	5.0	6.0	13.6	15	
		3.7**	2.76	5.3	5.0	5.0	-	5.0	6.0	14.1	15	
003A00	575-3-60	1.7	1.27	2.8	5.0	5.0	-	5.0	5.0	9.8	15	
		2.4	1.79	3.5	5.0	5.0	-	5.0	5.0	10.7	15	
		3.7	2.76	4.5	5.0	5.0	-	5.0	5.0	11.9	15	
004A00	208-3-60	1.7	1.27	5.8	10.0	7.5	-	7.5	20.8	33.3	35	
		2.4	1.79	7.1	10.0	7.5	-	7.5	20.8	34.9	35	
		3.7	2.76	10.8	10.0	7.5	-	7.5	20.8	39.6	40	
		3.7**	2.76	10.6	10.0	7.5	-	7.5	20.8	39.3	40	
	240-3-60	1.7	1.27	5.6	10.0	10.0	-	10.0	24.1	37.1	40	
		2.4	1.79	7.1	10.0	10.0	-	10.0	24.1	38.9	40	
		3.7	2.76	10.8	10.0	10.0	-	10.0	24.1	43.6	50	
		3.7**	2.76	10.6	10.0	10.0	-	10.0	24.1	43.3	50	
005A00	480-3-60	1.7	1.27	2.9	10.0	10.0	-	10.0	12.0	18.7	20	
		2.4	1.79	3.8	10.0	10.0	-	10.0	12.0	19.8	20	
		3.7	2.76	4.9	10.0	10.0	-	10.0	12.0	21.2	25	
		3.7**	2.76	5.3	10.0	10.0	-	10.0	12.0	21.7	25	
006A00	575-3-60	1.7	1.27	2.8	10.0	10.0	-	10.0	10.0	16.1	20	
		2.4	1.79	3.5	10.0	10.0	-	10.0	10.0	16.9	20	
		3.7	2.76	4.5	10.0	10.0	-	10.0	10.0	18.2	20	
007A00	208-3-60	1.7	1.27	5.8	15.0	11.3	-	11.3	31.3	46.4	50	
		2.4	1.79	7.1	15.0	11.3	-	11.3	31.3	48.0	50	
		3.7	2.76	10.8	15.0	11.3	-	11.3	31.3	52.6	60	
		3.7**	2.76	10.6	15.0	11.3	-	11.3	31.3	52.4	60	
	240-3-60	1.7	1.27	5.6	15.0	15.0	-	15.0	36.1	52.1	60	
		2.4	1.79	7.1	15.0	15.0	-	15.0	36.1	54.0	60	
		3.7	2.76	10.8	15.0	15.0	-	15.0	36.1	58.6	60	
		3.7**	2.76	10.6	15.0	15.0	-	15.0	36.1	58.4	60	
008A00	480-3-60	1.7	1.27	2.9	15.0	15.0	-	15.0	18.0	26.2	30	
		2.4	1.79	3.8	15.0	15.0	-	15.0	18.0	27.3	30	
		3.7	2.76	4.9	15.0	15.0	-	15.0	18.0	28.7	30	
		3.7**	2.76	5.3	15.0	15.0	-	15.0	18.0	29.2	30	
009A00	575-3-60	1.7	1.27	2.8	15.0	15.0	-	15.0	15.1	22.3	25	
		2.4	1.79	3.5	15.0	15.0	-	15.0	15.1	23.2	25	
		3.7	2.76	4.5	15.0	15.0	-	15.0	15.1	24.5	25	
010A00	208-3-60	1.7	1.27	5.8	25.0	11.3	7.5	18.8	52.1	72.4	80	
		2.4	1.79	7.1	25.0	11.3	7.5	18.8	52.1	74.0	80	
		3.7	2.76	10.8	25.0	11.3	7.5	18.8	52.1	78.7	80	
		3.7**	2.76	10.6	25.0	11.3	7.5	18.8	52.1	78.4	80	
	240-3-60	1.7	1.27	5.6	25.0	15.0	10.0	25.0	60.1	82.2	90	
		2.4	1.79	7.1	25.0	15.0	10.0	25.0	60.1	84.1	90	
		3.7	2.76	10.8	25.0	15.0	10.0	25.0	60.1	88.7	90	
		3.7**	2.76	10.6	25.0	15.0	10.0	25.0	60.1	88.4	90	

See: "Legend and Notes for Tables 5 and 6" on page 29.

# ELECTRICAL DATA (cont.)

**Table 6 - Electric Heater Data - 2-Speed Motor (cont)**

HEATER-PART NO.-CAELHEAT	SIZE	V-Ph-Hz	FAN MOTOR			ELECTRIC HEATER(S)					MCA*	MOCP*
						Nom. Cap. (kW)	Actual Capacity			FLA		
			HP	kW	FLA		Stage 1	Stage 2	Total			
011A00	40RUQ 07-12	480-3-60	1.7	1.27	2.9	25.0	15.0	10.0	25.0	30.1	41.2	50
			2.4	1.79	3.8	25.0	15.0	10.0	25.0	30.1	42.3	50
			3.7	2.76	4.9	25.0	15.0	10.0	25.0	30.1	43.7	50
			3.7**	2.76	5.3	25.0	15.0	10.0	25.0	30.1	44.2	50
012A00		575-3-60	1.7	1.27	2.8	25.0	15.0	10.0	25.0	25.1	34.9	35
			2.4	1.79	3.5	25.0	15.0	10.0	25.0	25.1	35.8	40
			3.7	2.76	4.5	25.0	15.0	10.0	25.0	25.1	37.0	40
013A00		208-3-60	1.7	1.27	5.8	35.0	15.0	11.3	26.3	73.0	98.5	100
			2.4	1.79	7.1	35.0	15.0	11.3	26.3	73.0	100.1	110
			3.7	2.76	10.8	35.0	15.0	11.3	26.3	73.0	104.7	110
			3.7**	2.76	10.6	35.0	15.0	11.3	26.3	73.0	104.5	110
		240-3-60	1.7	1.27	5.6	35.0	20.0	15.0	35.0	84.2	112.2	125
	2.4		1.79	7.1	35.0	20.0	15.0	35.0	84.2	114.1	125	
	3.7		2.76	10.8	35.0	20.0	15.0	35.0	84.2	118.7	125	
	3.7**		2.76	10.6	35.0	20.0	15.0	35.0	84.2	118.5	125	
014A00	480-3-60	1.7	1.27	2.9	35.0	20.0	15.0	35.0	42.1	56.2	60	
		2.4	1.79	3.8	35.0	20.0	15.0	35.0	42.1	57.4	60	
		3.7	2.76	4.9	35.0	20.0	15.0	35.0	42.1	58.7	60	
		3.7**	2.76	5.3	35.0	20.0	15.0	35.0	42.1	59.2	60	
015A00	575-3-60	1.7	1.27	2.8	35.0	20.0	15.0	35.0	35.1	47.4	50	
		2.4	1.79	3.5	35.0	20.0	15.0	35.0	35.1	48.3	50	
		3.7	2.76	4.5	35.0	20.0	15.0	35.0	35.1	49.6	50	
016A00	40RUQ 16	208-3-60	3.7	2.76	10.8	10.0	7.5	-	7.5	20.8	39.6	40
			5.0	3.73	18.0	10.0	7.5	-	7.5	20.8	48.6	60
	40RUQ 25	208-3-60	5.0	3.73	18.0	10.0	7.5	-	7.5	20.8	48.6	60
			7.5	5.59	23.5	10.0	7.5	-	7.5	20.8	55.4	70
	40RUQ 16	240-3-60	3.7	2.76	10.8	10.0	10.0	-	10.0	24.1	43.6	50
			5.0	3.73	18.0	10.0	10.0	-	10.0	24.1	52.6	60
40RUQ 25	240-3-60	5.0	3.73	18.0	10.0	10.0	-	10.0	24.1	52.6	60	
		7.5	5.59	23.5	10.0	10.0	-	10.0	24.1	59.4	70	
017A00	40RUQ 16	480-3-60	3.7	2.76	4.9	10.0	10.0	-	10.0	12.0	21.2	25
			5.0	3.73	9.1	10.0	10.0	-	10.0	12.0	26.4	30
	40RUQ 25	480-3-60	5.0	3.73	9.1	10.0	10.0	-	10.0	12.0	26.4	30
7.5	5.59		15.0	10.0	10.0	-	10.0	12.0	33.8	40		
018A00	40RUQ 16	575-3-60	3.7	2.76	4.5	10.0	10.0	-	10.0	10.0	18.2	20
			5.0	3.73	8.0	10.0	10.0	-	10.0	10.0	22.6	25
	40RUQ 25	575-3-60	5.0	3.73	8.0	10.0	10.0	-	10.0	10.0	22.6	25
			7.5	5.59	10.0	10.0	10.0	-	10.0	10.0	25.1	30
019A00	40RUQ 16	208-3-60	3.7	2.76	10.8	20.0	15.0	-	15.0	41.7	65.6	70
			5.0	3.73	18.0	20.0	15.0	-	15.0	41.7	74.6	80
	40RUQ 25	208-3-60	5.0	3.73	18.0	20.0	15.0	-	15.0	41.7	74.6	80
			7.5	5.59	23.5	20.0	15.0	-	15.0	41.7	81.5	90
	40RUQ 16	240-3-60	3.7	2.76	10.8	20.0	20.0	-	20.0	48.1	73.6	80
			5.0	3.73	18.0	20.0	20.0	-	20.0	48.1	82.6	90
40RUQ 25	240-3-60	5.0	3.73	18.0	20.0	20.0	-	20.0	48.1	82.6	90	
		7.5	5.59	23.5	20.0	20.0	-	20.0	48.1	89.5	100	
020A00	40RUQ 16	480-3-60	3.7	2.76	4.9	20.0	19.9	-	20.0	24.1	36.2	40
			5.0	3.73	9.1	20.0	19.9	-	20.0	24.1	41.4	50
	40RUQ 25	480-3-60	5.0	3.73	9.1	20.0	19.9	-	20.0	24.1	41.4	50
			7.5	5.59	15.0	20.0	19.9	-	20.0	24.1	48.8	50

**40RUQ**

See: "Legend and Notes for Tables 5 and 6" on page 29.

# ELECTRICAL DATA (cont.)

**Table 6 - Electric Heater Data - 2-Speed Motor (cont)**

**40RUQ**

HEATER PART NO. CAELHEAT	SIZE	V-PH-Hz	FAN MOTOR			ELECTRIC HEATER(S)					MCA*	MOCP*	
						Nom. Cap. (kW)	Actual Capacity (kW)			FLA			
			Hp	kW	FLA		Stage 1	Stage 2	Total				
021A00	40RUQ 16	575-3-60	3.7	2.76	4.5	20.0	20.0	-	20.0	20.1	30.7	35	
			5.0	3.73	8.0	20.0	20.0	-	20.0	20.1	35.1	40	
	40RUQ 25	575-3-60	5.0	3.73	8.0	20.0	20.0	-	20.0	20.1	35.1	40	
			7.5	5.59	10.0	20.0	20.0	-	20.0	20.1	37.6	40	
022A00	40RUQ 16	208-3-60	3.7	2.76	10.8	30.0	15.0	7.5	22.5	62.5	91.7	100	
			5.0	3.73	18.0	30.0	15.0	7.5	22.5	62.5	100.7	110	
	40RUQ 25	208-3-60	5.0	3.73	18.0	30.0	15.0	7.5	22.5	62.5	100.7	110	
			7.5	5.59	23.5	30.0	15.0	7.5	22.5	62.5	107.5	110	
	40RUQ 16	240-3-60	3.7	2.76	10.8	30.0	20.0	10.0	30.0	72.2	103.7	110	
			5.0	3.73	18.0	30.0	20.0	10.0	30.0	72.2	112.7	125	
		40RUQ 25	240-3-60	5.0	3.73	18.0	30.0	20.0	10.0	30.0	72.2	112.7	125
				7.5	5.59	23.5	30.0	20.0	10.0	30.0	72.2	119.6	125
023A00	40RUQ 16	480-3-60	3.7	2.76	4.9	30.0	20.0	10.0	30.0	36.1	51.2	60	
			5.0	3.73	9.1	30.0	20.0	10.0	30.0	36.1	56.5	60	
	40RUQ 25	480-3-60	5.0	3.73	9.1	30.0	20.0	10.0	30.0	36.1	56.5	60	
			7.5	5.59	15.0	30.0	20.0	10.0	30.0	36.1	63.9	70	
024A00	40RUQ 16	575-3-60	3.7	2.76	4.5	30.0	20.0	10.0	30.0	30.1	43.3	50	
			5.0	3.73	8.0	30.0	20.0	10.0	30.0	30.1	47.7	50	
	40RUQ 25	575-3-60	5.0	3.73	8.0	30.0	20.0	10.0	30.0	30.1	47.7	50	
			7.5	5.59	10.0	30.0	20.0	10.0	30.0	30.1	50.2	60	
025A00	40RUQ 16	208-3-60	3.7	2.76	10.8	50.0	22.6	15.0	37.5	104.3	143.8	150	
			5.0	3.73	18.0	50.0	22.6	15.0	37.6	104.3	152.8	175	
	40RUQ 25	208-3-60	5.0	3.73	18.0	50.0	22.6	15.0	37.6	104.3	152.8	175	
			7.5	5.59	23.5	50.0	22.6	15.0	37.6	104.3	159.7	175	
	40RUQ 16	240-3-60	3.7	2.76	10.8	50.0	30.0	20.0	50.0	120.3	163.9	175	
			5.0	3.73	18.0	50.0	30.0	20.0	50.0	120.3	172.9	175	
40RUQ 25	240-3-60	5.0	3.73	18.0	50.0	30.0	20.0	50.0	120.3	172.9	175		
		7.5	5.59	23.5	50.0	30.0	20.0	50.0	120.3	172.9	200		
026A00	40RUQ 16	480-3-60	3.7	2.76	4.9	50.0	30.0	20.0	50.0	60.1	81.3	90	
			5.0	3.73	9.1	50.0	30.0	20.0	50.0	60.1	86.6	90	
	40RUQ 25	480-3-60	5.0	3.73	9.1	50.0	30.0	20.0	50.0	60.1	86.6	90	
			7.5	5.59	15.0	50.0	30.0	20.0	50.0	60.1	93.9	100	
027A00	40RUQ 16	575-3-60	3.7	2.76	4.5	50.0	30.0	20.0	50.0	50.2	68.4	70	
			5.0	3.73	8.0	50.0	30.0	20.0	50.0	50.2	72.8	80	
	40RUQ 25	575-3-60	5.0	3.73	8.0	50.0	30.0	20.0	50.0	50.2	72.8	80	
			7.5	5.59	10.0	50.0	30.0	20.0	50.0	50.2	75.3	80	

See: "Legend and Notes for Tables 5 and 6" on page 29.

# ELECTRICAL DATA (cont.)

## Legend and Notes for Tables 5 and 6

### LEGEND

- FLA** — Full Load Amps
- Hp** — Horsepower
- MCA** — Minimum Circuit Amps
- MOCP** — Maximum Overcurrent Protection (Amps)

\* Values shown are for single-point connection of electric heat accessory and air handler.

\*\* High Efficiency Motor

† Single-phase motors. All other motors are 3-phase.

### NOTES:

1. Electrical resistance heaters are rated at 240 v, 480 v, or 575 v. To determine heater capacity (kW) at unit nameplate multiply the 240-v, 480-v, or 575-v capacity (kW) by the factor shown in the table below for the unit voltage.

HEATER RATING VOLTAGE	ACTUAL HEATER VOLTAGE										
	200	208	230	240	400	440	460	480	550	575	600
240	0.694	0.751	0.918	1	—	—	—	—	—	—	—
480	—	—	—	—	0.694	0.84	0.918	1	—	—	—
575	—	—	—	—	—	—	—	—	0.915	1	1.089

2. The following equation converts kW of heat energy to Btuh:  $kW \times 3,412 = Btuh$ .
3. Heater contactor coils are 24 v and require 8 va holding current.
4. Electric heaters are tested and ETL approved at maximum total external static pressure of 1.9 in. wg.
5. MCA and MOCP values apply to both standard and alternate factory-supplied motors.
6. Approximate shipping weight for CAELHEAT001A00-015A00 is 55 lb (25 kg) each. Approximate shipping weight for CAELHEAT016A00-027A00 is 60 lb (27 kg) each, and CAELHEAT028A00-039A00 is 75 lb (34 kg) each.



40RUQ

# TYPICAL PIPING AND WIRING

## HORIZONTAL INSTALLATION

40RUQ

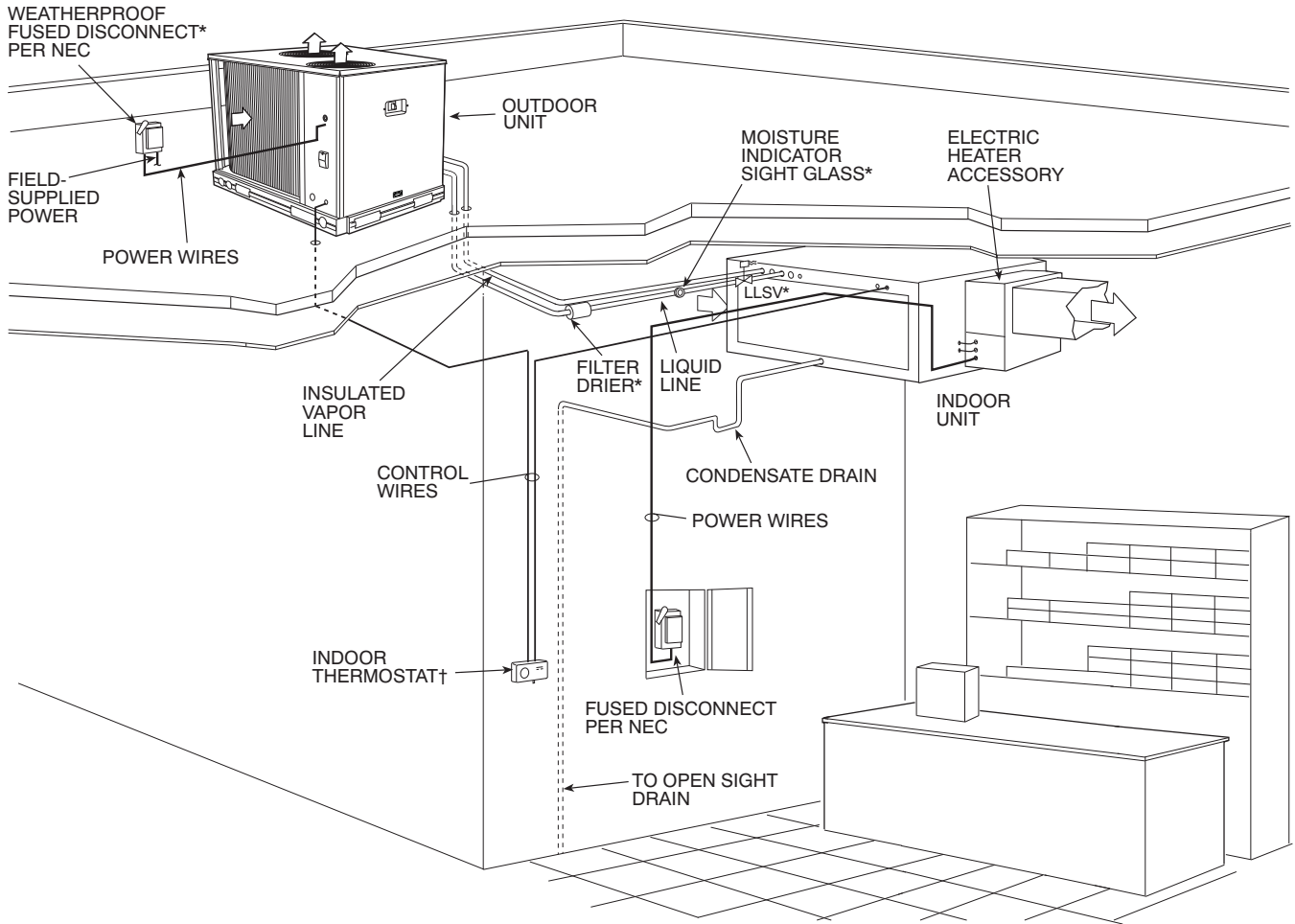

C09054

# TYPICAL PIPING AND WIRING (cont.)

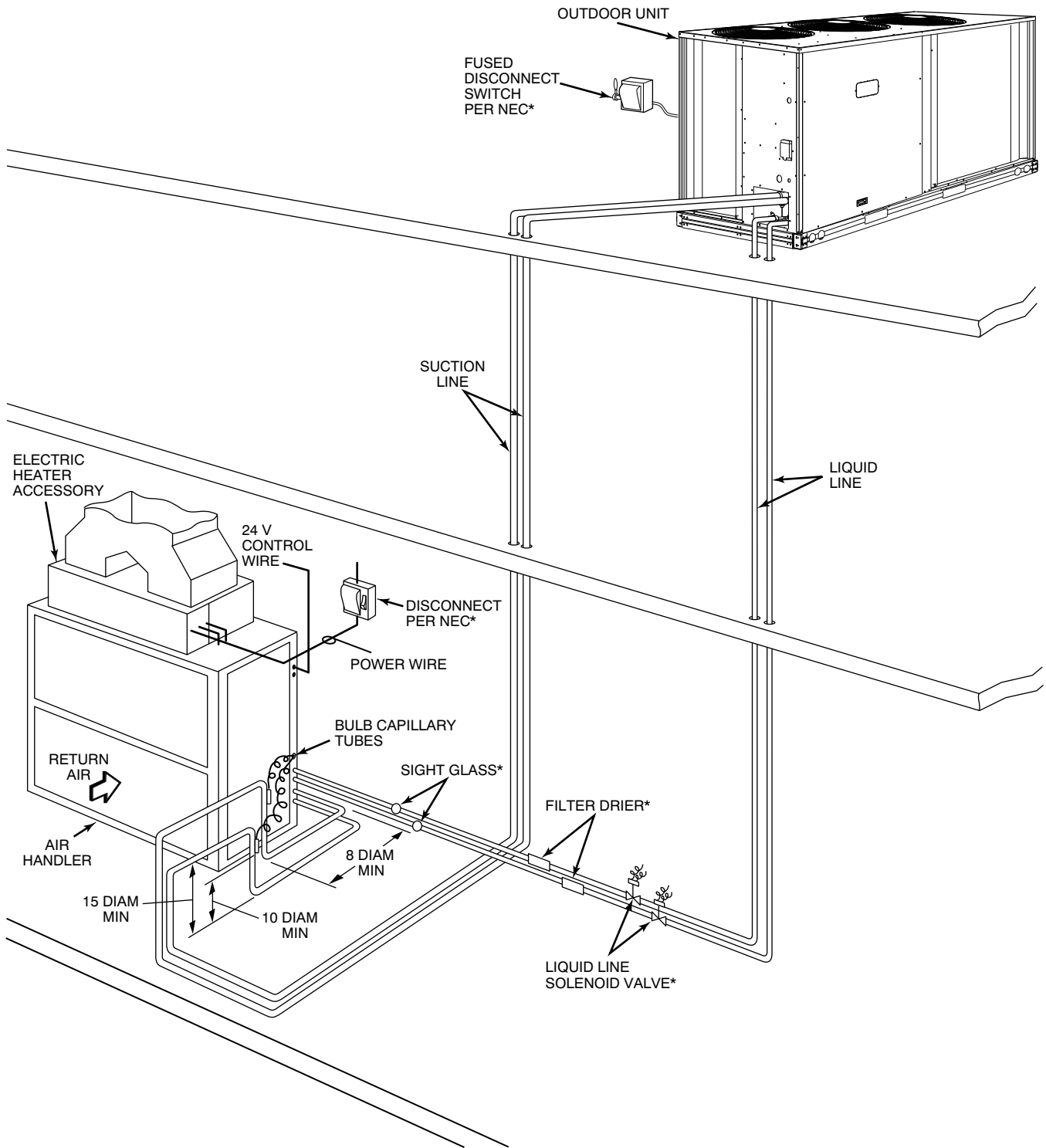

40RUQ

### LEGEND

- DIAM** — Diameter
- NEC** — National Electrical Code
- TXV** — Thermostatic Expansion Valve
- Piping

\*Field supplied

### NOTES:

1. All piping must follow standard refrigerant piping techniques. Refer to System Design Manual for details.
2. All wiring must comply with applicable local and national codes.
3. Wiring and piping shown are general points-of-connection guides only and are not intended for, or to include all details for, a specific installation.
4. Filter driers must be bi-flow type suited for heat pump duty.
5. Liquid line solenoid valve (solenoid drop control) is recommended to prevent refrigerant migration to the compressor on line links above 75 feet.
6. Internal factory-supplied TXVs and check valves not shown.

C150436

# TYPICAL CONTROL WIRING SCHEMATIC

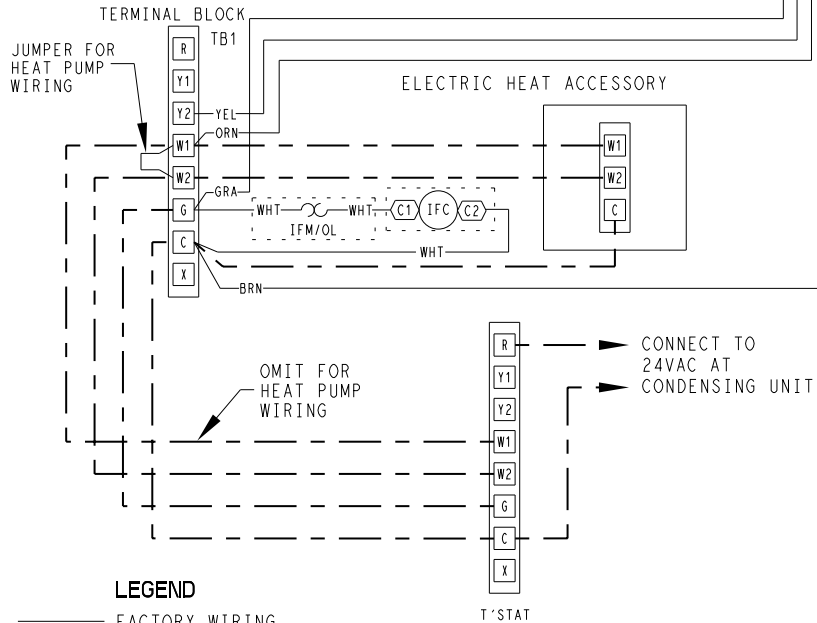
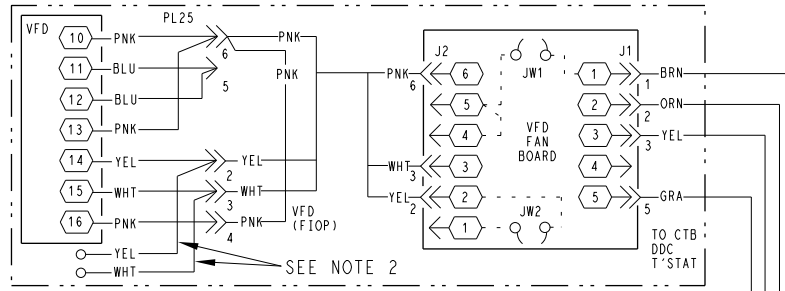
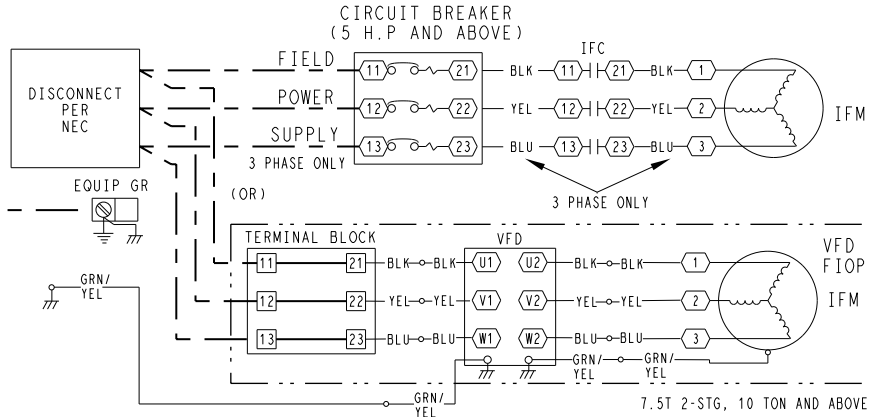

## LEGEND

- FACTORY WIRING
- - - - FIELD CONTROL WIRING
- CB CIRCUIT BREAKER
- IFC INDOOR FAN CONTACTOR
- IFM INDOOR FAN MOTOR
- TB TERMINAL BLOCK
- T' STAT THERMOSTAT
- VFD VARIABLE FREQUENCY DRIVE

## NOTES:

1. USE COPPER CONDUCTORS ONLY.
2. FOR HIGH SPEED BLOWER TESTING, CONNECT YELLOW AND WHITE WIRES. DISCONNECT FOR NORMAL OPERATION.

40RM501370 H

40RUQ



## APPLICATION DATA

### General

**IMPORTANT:** Do not bury refrigerant piping underground.

Select equipment to match or to be slightly less than peak load. This provides better humidity control, less unit cycling, and less part-load operation. Equipment should be selected to perform at no less than 300 cfm/ton (40 L/s per kW).

The air handler fan must always be operating when the condensing unit is operating.

Ductwork should be sized according to unit size, not building load. For larger units with two fans, a split duct transition is recommended at the fan outlets, but a plenum can be used with slight reduction in external static pressure capability.

### FAN MOTOR DATA STANDARD MOTOR – Single Speed

UNIT	40RUQ*07	40RUQ*08	40RUQ*12	40RUQ*16	40RUQ*25
<b>208/230-1-60</b>					
Speed (rpm)	1725	1725	—	—	—
Hp	1.3	2.4	—	—	—
Frame (NEMA)	56Y	56Y	—	—	—
Shaft Dia (in.)	5/8	5/8	—	—	—
<b>230-3-60 and 460-3-60</b>					
Speed (rpm)	1750	1750	1750	1750	1755
Hp	2.4	2.4	2.4	3.7	5.0
Frame (NEMA)	56Y	56Y	56Y	56HZ	184T
Shaft Dia (in.)	5/8	5/8	5/8	7/8	1 1/8
<b>575-3-60</b>					
Speed (rpm)	1725	1725	1725	1725	1755
Hp	1.0	2.0	2.0	3.0	5.0
Frame (NEMA)	56	56HZ	56HZ	56HZ	184T
Shaft Dia (in.)	5/8	7/8	7/8	7/8	1 1/8

**LEGEND:**

**NEMA** — National Electrical Manufacturers Association (U.S.A.)

### FAN MOTOR DATA ALTERNATE MOTOR – Single Speed

UNIT	40RUQ*07	40RUQ*08	40RUQ*12	40RUQ*16	40RUQ*25
<b>208/230-1-60</b>					
Speed (rpm)	1725	1725	—	—	—
Hp	2.4	2.4	—	—	—
Frame (NEMA)	56Y	56Y	—	—	—
Shaft Dia (in.)	5/8	5/8	—	—	—
<b>230-3-60 and 460-3-60</b>					
Speed (rpm)	1750	1750	1750	1755	1760
Hp	2.9	2.9	3.7	5.0	7.5
Frame (NEMA)	56Y	56Y	56HZ	184T	S213T
Shaft Dia (in.)	7/8	7/8	7/8	1 1/8	1 3/8
<b>575-3-60</b>					
Speed (rpm)	1725	1725	1725	1755	1760
Hp	2.0	3.0	3.0	5.0	7.5
Frame (NEMA)	56HZ	56HZ	56HZ	184T	S213T
Shaft Dia (in.)	7/8	7/8	7/8	1 1/8	1 3/8

**LEGEND:**

**NEMA** — National Electrical Manufacturers Association (U.S.A.)

### MOTOR EFFICIENCY – Single Speed Motor

MOTOR HP	EPACT MINIMUM	MOTOR EFFICIENCY
1.3*	—	70.0%
2.4	—	76.8%
2.9	—	77.1%
3.7	—	81.5%
5.0	89.5%	89.5%
7.5	91.7%	91.7%
10.0	91.7%	91.7%

**LEGEND:**

**EPACT** — Energy Policy and Conservation Act of 1992

\* Single-phase only.

**40RUQ**

## APPLICATION DATA (cont.)

### FAN MOTOR DATA STANDARD MOTOR – Two Speed

UNIT	40RUQ*07	40RUQ*08	40RUQ*12	40RUQ*16	40RUQ*25
<b>230-3-60 and 460-3-60</b>					
Speed (rpm)	1680	1680	1690	1750	1755
Hp	2.4	2.4	1.7	3.7	5.0
Frame (NEMA)	56HY	56HY	56HY	56HY	184T
Shaft Dia (in.)	$\frac{5}{8}$	$\frac{5}{8}$	$\frac{5}{8}$	$\frac{7}{8}$	$1\frac{1}{8}$
<b>575-3-60</b>					
Speed (rpm)	1680	1680	1665	1710	1755
Hp	2.4	2.4	1.7	3.7	5.0
Frame (NEMA)	56HY	56HY	56HY	56HY	184T
Shaft Dia (in.)	$\frac{5}{8}$	$\frac{5}{8}$	$\frac{5}{8}$	$\frac{7}{8}$	$1\frac{1}{8}$

**LEGEND:**

**NEMA** — National Electrical Manufacturers Association (U.S.A.)

### FAN MOTOR DATA ALTERNATE MOTOR – Two Speed

UNIT	40RUQ*07	40RUQ*08	40RUQ*12	40RUQ*16	40RUQ*25
<b>230-3-60 and 460-3-60</b>					
Speed (rpm)	1750	1750	1725	1755	1760
Hp	3.7	3.7	3.7 <sup>†</sup>	5.0	7.5
Frame (NEMA)	56HY	56HY	56HY	184T	S213T
Shaft Dia (in.)	$\frac{7}{8}$	$\frac{7}{8}$	$\frac{7}{8}$	$1\frac{1}{8}$	$1\frac{3}{8}$
<b>575-3-60</b>					
Speed (rpm)	1710	1710	1710	1755	1750
Hp	3.7	3.7	3.7	5.0	7.5
Frame (NEMA)	56HY	56HY	56HY	184T	S213T
Shaft Dia (in.)	$\frac{7}{8}$	$\frac{7}{8}$	$\frac{7}{8}$	$1\frac{1}{8}$	$1\frac{3}{8}$

**LEGEND:**

**NEMA** — National Electrical Manufacturers Association (U.S.A.)

<sup>†</sup> High Efficiency Motor.

### MOTOR EFFICIENCY – Two Speed Motor

MOTOR HP	EPACT MINIMUM	MOTOR EFFICIENCY
1.7	—	82.0%
2.4	—	80.0%
2.9	—	86.5%
3.7	—	83.6%
3.7*	—	87.9%
5.0	89.5%	89.5%
7.5	91.7%	91.7%
10.0	91.7%	91.7%

**LEGEND:**

**EPACT** — Energy Policy and Conservation Act of 1992

\* High Efficiency Motor.

# APPLICATION DATA (cont.)

## STANDARD DRIVE DATA

UNIT	40RUQ07	40RUQ08	40RUQ12	40RUQ16	40RUQ25
<b>MOTOR DRIVE</b>					
Motor Pulley Pitch Dia (in.)	2.4-3.4	2.8-3.8	3.4-4.4	2.8-3.8	3.7-4.7
Pulley Factory Setting Full Turns Open	2.5	2.5	2.5	2.5	3.0
<b>FAN DRIVE</b>					
Pulley Pitch Dia (in.)	8.8	8.8	8.8	9.0	9.4
Pulley Bore (in.)	1	1	1	1 <sup>7</sup> / <sub>16</sub>	1 <sup>7</sup> / <sub>16</sub>
Belt No. — Section	1—A	1—A	1—A	1—A	1—B
Belt Pitch (in.)	40.3	41.3	42.3	42.3	41.8
<b>FAN SPEEDS (rpm)</b>					
Factory Settings	568	647	764	632	771
Range	470-666	549-745	666-863	537-728	679-863
Max Allowable Speed (rpm)	1200	1200	1200	1200	1200
Change per 1/2 turn of Moveable Motor Pulley Flange	19.6	19.6	19.7	19.1	15.3
<b>MAX FULL TURNS FROM CLOSED POSITION</b>					
	5	5	5	5	6
<b>SHAFTS CENTER DISTANCE (in.)</b>					
	10.44 - 12.32	10.44 - 12.32	10.44 - 12.32	10.44 - 12.32	9.12 - 10.99

40RUQ

## MEDIUM-STATIC DRIVE DATA

UNIT	40RUQ07	40RUQ08	40RUQ12	40RUQ16	40RUQ25
<b>MOTOR DRIVE</b>					
Motor Pulley Pitch Dia (in.)	3.4-4.4	3.4-4.4	3.4-4.4	3.7-4.7	4.3-5.3
Pulley Factory Setting Full Turns Open	2.5	2.5	2.5	3.0	3.0
<b>FAN DRIVE</b>					
Pulley Pitch Dia (in.)	8.8	8.0	8.0	8.6	9.4
Pulley Bore (in.)	1	1	1	1 <sup>7</sup> / <sub>16</sub>	1 <sup>7</sup> / <sub>16</sub>
Belt No. — Section	1—A	1—A	1—A	1—B	1—B
Belt Pitch (in.)	42.3	40.3	40.3	41.8	41.8
<b>FAN SPEEDS (rpm)</b>					
Factory Setting	764	841	841	842	881
Range	666 - 863	733 - 949	733 - 949	742 - 943	798 - 984
Max Allowable Speed (rpm)	1200	1200	1200	1200	1200
Change per 1/2 Turn of Moveable Motor Pulley Flange	19.7	21.6	21.6	16.7	15.3
<b>MAX FULL TURNS FROM CLOSED POSITION</b>					
	5	5	5	6	6
<b>SHAFTS CENTER DISTANCE (in.)</b>					
	10.44 - 12.32	10.44 - 12.32	10.44 - 12.32	10.44 - 12.32	9.16 - 10.99

## HIGH-STATIC DRIVE DATA

UNIT	40RUQ07	40RUQ08	40RUQ12	40RUQ16	40RUQ25
<b>MOTOR DRIVE</b>					
Motor Pulley Pitch Dia (in.)	3.4-4.4	3.4-4.4	3.4-4.4	4.3-5.3	4.3-5.3
Pulley Factory Setting Full Turns Open	2.5	2.5	2.5	3.0	3.0
<b>FAN DRIVE</b>					
Pulley Pitch Dia (in.)	7.0	6.0*	6.0	7.9	7.4
Pulley Bore (in.)	1	1	1	1 <sup>7</sup> / <sub>16</sub>	1 <sup>7</sup> / <sub>16</sub>
Belt No. — Section	1—A	1—A	1—A	1—B	2—B
Belt Pitch (in.)	41.3	37.3	37.3	39.8	36.8
<b>FAN SPEEDS (rpm)</b>					
Factory Setting	961	1121	1121	1060	1118
Range	838 - 1084	978 - 1200*†	978 - 1200†	950 - 1171	1014 - 1200†
Max Allowable Speed (rpm)	1200	1200	1200	1200	1200
Change per 1/2 Turn of Moveable Motor Pulley Flange	24.6	28.7	28.7	18.4	19.4
<b>MAX FULL TURNS FROM CLOSED POSITION</b>					
	5	5	5	6	6
<b>SHAFTS CENTER DISTANCE (in.)</b>					
	10.44 - 12.32	10.44 - 12.32	10.44 - 12.32	9.16 - 10.99	8.16 - 10.02

\* Values for 3-phase motor shown. For single-phase motor, pulley pitch diameter is 7 in. and resulting fan speed is 837-1096 rpm.

† It is possible to adjust drive so that fan speed exceeds maximum allowable. DO NOT exceed 1200 rpm.

# GUIDE SPECIFICATIONS — 40RUQ 07-25

## Split System Heat Pump Indoor Unit (Air-Handling Unit) with PURON® Refrigerant

### HVAC Guide Specifications — Section 15859

Size Range: **2,400 to 8,000 Cfm, Nominal Airflow**  
**6 to 20 Tons, Nominal Cooling**

Carrier Model Numbers: **40RUQ\*07-25**

#### Part 1 — General

##### 1.01 SYSTEM DESCRIPTION

- A. Indoor, packaged air-handling unit for use in commercial heat pump split systems. Unit shall have a multi-position design and shall be capable of horizontal or vertical installation on a floor or in a ceiling, with or without ductwork. (Only vertical units are to be applied without ductwork.) Unit shall function as the indoor component of an air-to-air electric heat pump system.
- B. Unit must be designed with a Puron® (R-410A) refrigerant circuit with a matching air-cooled condensing unit 38AUQ, for matched systems approved by the manufacturer.

##### 1.02 QUALITY ASSURANCE

- A. All coils shall be designed and tested in accordance with ASHRAE 15 Safety Code for Mechanical Refrigeration, latest edition.
- B. Unit shall be constructed in accordance with ETL and ETL, Canada, standards and shall carry the ETL and ETL, Canada, labels.
- C. Unit insulation and adhesive shall comply with NFPA-90A requirements for flame spread and smoke generation. Insulation shall contain an EPA-registered immobilized antimicrobial agent to effectively resist the growth of bacteria and fungi as proven by tests in accordance with ASTM standards G21 and 22.
- D. Unit shall be manufactured in a facility registered to the ISO 9001 manufacturing quality standard.
- E. Direct-expansion coils shall be leak tested at 150 psig and pressure tested at 650 psig and qualified to UL burst test at 1980 psig.

##### 1.03 DELIVERY AND STORAGE

Units shall be stored and handled per manufacturer's recommendations.

#### Part 2 — Products

##### 2.01 EQUIPMENT

Indoor mounted, draw-thru, packaged air-handling unit that can be used with or without ductwork in a suspended horizontal configuration or free-standing vertical configuration. Unit shall be indoor component of a heat pump system. Unit shall consist of forward-curved belt-driven centrifugal fan(s), motor and drive assembly, prewired fan motor contactor, factory-installed refrigerant metering devices, bypass check valves, cooling coil, 2-in. disposable air filters, and condensate drain pans for vertical or horizontal configurations.

###### A. Base Unit:

- 1. Cabinet shall be constructed of mill-galvanized steel.
- 2. Cabinet panels shall be fully insulated with 1/2-in. fire-retardant material. Insulation shall contain an EPA-registered immobilized antimicrobial agent to effectively resist the growth of bacteria and fungi as proven by tests in accordance with ASTM standards G21 and 22.
- 3. Unit shall contain corrosion-free condensate drain pans for both vertical and horizontal applications. Drain pans shall have connections on right and left sides of unit to facilitate field connection. Drain pans shall have the ability to be sloped toward the right or left side of the unit to prevent standing water from accumulating in pans.
- 4. Unit shall have factory-supplied 2-in. throwaway-type filters installed upstream from the cooling coil. Filter access shall be from either the right or left side of the unit.

###### B. Coils:

- 1. Coils shall consist of 3 rows (40RUQ\*07) or 4 rows (40RUQ\*08 - 25) of copper tubes with sine-wave aluminum fins bonded to the tubes by mechanical expansion. Coil tubing shall be internally rifled to maximize heat transfer. Refrigerant line connections shall be made on the same side of the coil.
- 2. Coils shall feature factory-installed thermostatic expansion valves (TXVs) for refrigerant control. The TXVs shall be capable of external adjustment.

3. Coils shall have a factory-installed bypass line and check valve assembly around the TXVs to allow liquid flow from the coil to the outdoor unit during Heating mode.
- C. Operating Characteristics:
1. When combined with the matching 38AUQ condensing unit the system shall be capable of starting and running up to 125°F (52°C) and down to 35°F (2°C) ambient outdoor temperature.
  2. Unit shall operate at +/- 10% from rated voltage
- D. Motor:
1. Fan motor of the size and electrical characteristics specified on the equipment schedule shall be factory-supplied and factory-installed.
  2. Indoor-fan motor shall have permanently lubricated, sealed bearings and inherent automatic-reset thermal overload protection (motors smaller than 5 hp) or manual reset calibrated circuit breakers (motors equal or larger than 5 hp). Indoor motors are designed specifically for Carrier and do not have conventional horsepower (hp) ratings listed on the motor nameplate. Motors are designed and qualified in the “air-over” location downstream of the cooling coil and carry a maximum continuous bhp rating that is the maximum application bhp rating for the motors; no “safety factors” above that rating may be applied.
  3. All indoor fan motors 5 hp and larger shall meet the minimum efficiency requirements as established by the Energy Policy Act of 1992 (EPA), effective October 24, 1997.
  4. High efficient motors listed shall meet section 313 of the Energy Independence and Security Act of 2007 (EISA 2007).
- E. Special Features:
1. Alternate Motor and Drive:  
An alternate motor and medium or high-static drive shall be available to meet the airflow and external static pressure requirements specified on the equipment schedule.
  2. External Paint Cabinet:  
Where conditions require, units shall be painted with an American Sterling Gray finish.
  3. Hot Water Coil:  
Coil shall be 2-row, U-bend coil with copper tubes and aluminum plate fins bonded to the tubes by mechanical expansion. Coil shall be mounted in a galvanized steel housing that shall be fastened to the unit’s fan deck for blow-thru heating operation. Coil shall have maximum working pressure of 150 psig.
  4. Steam Distributing Coil:  
Coil shall consist of one row of copper tubes with aluminum plate fins, and shall have inner steam distributing tubes. Coil shall be mounted in a galvanized steel housing and shall be fastened to the unit’s fan deck for blow-thru heating operation. Coil shall have maximum working pressure of 20 psig at 260°F.
  5. Electric Heaters:  
Heaters for nominal 240, 480, or 575-volt, 3-phase, 60 Hz power supply shall be factory-supplied for field installation as shown on the equipment drawings. Electric heat assembly shall be ETL and ETL, Canada; agency approved, and shall have single-point power wiring. Heater assembly shall include contactors with 24-v coils, power wiring, 24-v control wiring terminal blocks, and a hinged access panel.
  6. Air Discharge Plenum:  
Plenum shall be factory-supplied to provide free-blow air distribution for vertical floor-mounted units. A grille with moveable vanes for horizontal or vertical airflow adjustment shall be included. Plenum housing shall be field-installed on the unit’s fan deck for blow-thru air distribution.
  7. Return Air Grille:  
Grille shall be factory-supplied for field installation on the unit’s return air opening.
  8. Unit Subbase:  
Subbase assembly shall be factory-supplied for field installation. Subbase shall elevate floor-mounted vertical units to provide access for correct condensate drain connection.
  9. Economizers:
    - a. Accessory **Ultra LOW LEAK** EconoMi\$er X. (Field installed)  
Economizer for ventilation or “free” cooling shall be factory provided for field installation on either return air opening of air handler.
      - (1.) Integrated, gear driven opposing modulating blade design type capable of simultaneous economizer and compressor operation.
      - (2.) Damper blades shall be galvanized steel with composite gears. Plastic or composite blades on intake or return shall not be acceptable.
      - (3.) Shall include all hardware, actuator and controls to provide free cooling with outdoor air when temperature and/or humidity are below setpoints.

- (4.) Shall be equipped with gear driven dampers for both the outdoor ventilation air and the return air for positive air stream control
  - (5.) Ultra LOW LEAK design meets California Title 24 section 140.4 and ASHRAE90.1 requirements for 4 cfm per sq. ft. on the outside air dampers and 10 cfm per sq. ft. on the return dampers.
  - (6.) Economizer controller on EconoMi\$er X models shall be the Honeywell W7220 that provides:
    - i. 2-line LCD interface screen for setup, configuration and troubleshooting
    - ii. On-board Fault Detection and Diagnostics (FDD) that senses and alerts when the economizer is not operating properly, per California Title 24.
    - iii. Sensor failure loss of communication identification
    - iv. Automatic sensor detection
    - v. Capabilities for use with multiple-speed indoor fan systems
    - vi. Utilizing digital sensors: Dry bulb and Enthalpy. Accessory comes standard with dry bulb sensing.
    - vii. Field installing enthalpy sensor required.
- b. Accessory Standard Leak EconoMi\$er IV (Field installed)
- Economizer for ventilation or “free” cooling shall be factory provided for field installation on either return air opening of air handler.
- (1.) Integrated, gear driven opposing modulating blade design type capable of simultaneous economizer and compressor operation.
  - (2.) Damper blades shall be galvanized steel with composite gears. Plastic or composite blades on intake or return shall not be acceptable.
  - (3.) Shall include all hardware, actuator and controls to provide free cooling with outdoor air when temperature and/or humidity are below setpoints.
  - (4.) Shall be equipped with gear driven dampers for both the outdoor ventilation air and the return air for positive air stream control
  - (5.) Standard leak rate shall be equipped with dampers not to exceed 2% leakage at 1 in. wg pressure differential.
  - (6.) Economizer controller on EconoMi\$er IV models shall be Honeywell W7212 that provides:
    - i. Combined minimum and DCV maximum damper position potentiometers with compressor staging relay.
    - ii. Functions with solid state analog enthalpy or dry bulb changeover control sensing.
    - iii. Contains LED indicates for:
      - when free cooling is available, when module is in DCV mode, when exhaust fan is closed.
10. Overhead Suspension Package:  
Package shall include necessary brackets to support units in a horizontal ceiling installation.
11. CO2 Sensor:  
Sensor shall provide the ability to signal the economizer to open when the space CO2 level exceeds the predetermined set point. Sensor shall have the capability of being connected to Comfort System relay pack or to economizer using field-supplied and field-installed Honeywell dc adapter no. Q769C1004.
12. Condensate Drain Trap:  
Trap shall have transparent, serviceable design for easy cleaning. Kit shall also include overflow shutoff switch and wiring harness for connection to alarm if desired.
13. Staged Air Volume System (SAV) for 2-stage cooling models only:
- a. Evaporator fan motor:
    - (1.) Shall have permanently lubricated bearings.
    - (2.) Shall have a maximum continuous bhp rating for continuous duty operation; no safety factors above that rating.
    - (3.) Shall be Variable Frequency duty and 2-speed control.
    - (4.) Shall contain motor shaft grounding ring to prevent electrical bearing fluting damage by safely diverting harmful shaft voltages and bearing currents to ground.
14. Variable Frequency Drive (VFD). Only available on 2-speed indoor fan motor option Staged Air Volume System (SAV™):
- (1.) Shall be installed inside the unit cabinet, mounted, wired and tested.
  - (2.) Shall contain Electromagnetic Interference (EMI) frequency protection.
  - (3.) Insulated Gate Bi-Polar Transistors (IGBT) used to produce the output pulse width modulated (PWM) waveform, allowing for quiet motor operation.

- (4.) Self diagnostics with fault and power code LED indicator. Field accessory Display kit available for further diagnostics and special setup applications.
- (5.) RS485 capability standard
- (6.) Electronic thermal overload protection
- (7.) 5% swinging chokes for harmonic reduction and improved power factor
- (8.) All printed circuit boards shall be conformal coated.

15. Display Kit for Variable Frequency Drive

- a. Kit allows the ability to access the VFD controller programs to provide special setup capabilities and diagnostics.
- b. Kit contains display module and communications cable.
- c. Display Kit can be permanently installed in the unit or used on any SAV system VFD controller as needed.

