

Installation Instructions



Fig. 1 – Sizes 09–48



Fig. 2 – Size 58

NOTES:

Read the entire instruction manual before starting the installation.

Images are for illustration purposes only. Actual models may differ slightly.

TABLE OF CONTENTS

	PAGE
SAFETY CONSIDERATIONS	2
PARTS LIST	3
SYSTEM REQUIREMENTS	4
WIRING	4
DIMENSIONS	5
INSTALLATION CLEARANCES	7
MAINTENANCE CLEARANCES	7
INSTALLATION LOCATION REQUIREMENTS	8
INDOOR UNIT INSTALLATION	8
EXTERNAL STATIC PRESSURE	12
FAN PERFORMANCES AT VARYING STATIC PRESSURES	13
ELECTRICAL DATA	21
CONNECTION DIAGRAMS	21
START-UP	24
TROUBLESHOOTING	25

SAFETY CONSIDERATIONS

Installing, starting up, and servicing air-conditioning equipment can be hazardous due to system pressures, electrical components, and equipment location (roofs, elevated structures, etc.).

Only trained, qualified installers and service mechanics should install, start-up, and service this equipment.

Untrained personnel can perform basic maintenance functions such as cleaning coils. All other operations should be performed by trained service personnel.

When working on the equipment, observe precautions in the literature and on tags, stickers, and labels attached to the equipment.

Follow all safety codes. Wear safety glasses and work gloves. Keep quenching cloth and fire extinguisher nearby when brazing. Use care in handling, rigging, and setting bulky equipment.

Read these instructions thoroughly and follow all warnings or cautions included in literature and attached to the unit. Consult local building codes and National Electrical Code (NEC) for special requirements. Recognize safety information.

This is the safety-alert symbol. When you see this symbol on the unit and in instructions or manuals, be alert to the potential for personal injury. Understand these signal words: **DANGER**, **WARNING**, and **CAUTION**. These words are used with the safety-alert symbol. **DANGER** identifies the most serious hazards which **will** result in severe personal injury or death. **WARNING** signifies hazards which **could** result in personal injury or death. **CAUTION** is used to identify unsafe practices which **may** result in minor personal injury or product and property damage. **NOTE** is used to highlight suggestions which **will** result in enhanced installation, reliability, or operation.

WARNING

The 9 and 12K units are for single room application **only**.



WARNING

ELECTRICAL SHOCK HAZARD

Failure to follow this warning could result in personal injury or death.

Before installing, modifying, or servicing system, main electrical disconnect switch must be in the OFF position. There may be more than 1 disconnect switch. Lock out and tag switch with a suitable warning label.



WARNING



EXPLOSION HAZARD

Failure to follow this warning could result in death, serious personal injury, and/or property damage.

Never use air or gases containing oxygen for leak testing or operating refrigerant compressors. Pressurized mixtures of air or gases containing oxygen can lead to an explosion.



CAUTION

EQUIPMENT DAMAGE HAZARD

Failure to follow this caution may result in equipment damage or improper operation.

Do not bury more than 36 in. (914 mm) of refrigerant pipe in the ground. If any section of pipe is buried, there must be a 6 in. (152 mm) vertical rise to the valve connections on the outdoor units. If more than the recommended length is buried, refrigerant may migrate to the cooler buried section during extended periods of system shutdown. This causes refrigerant slugging and could possibly damage the compressor at start-up.

PARTS LIST

Table 1 – Parts List

PART NAME
INDOOR UNIT
DRAIN ADAPTER
AIR FILTER
WIRED CONTROLLER
WIRELESS REMOTE
LITERATURE PACKAGE INCLUDING INSTALLATION INSTRUCTIONS AND WARRANTY
CONDENSATE LIFT PUMP (EXTERNAL SIZES 09–18, INTERNAL SIZES 24–58)

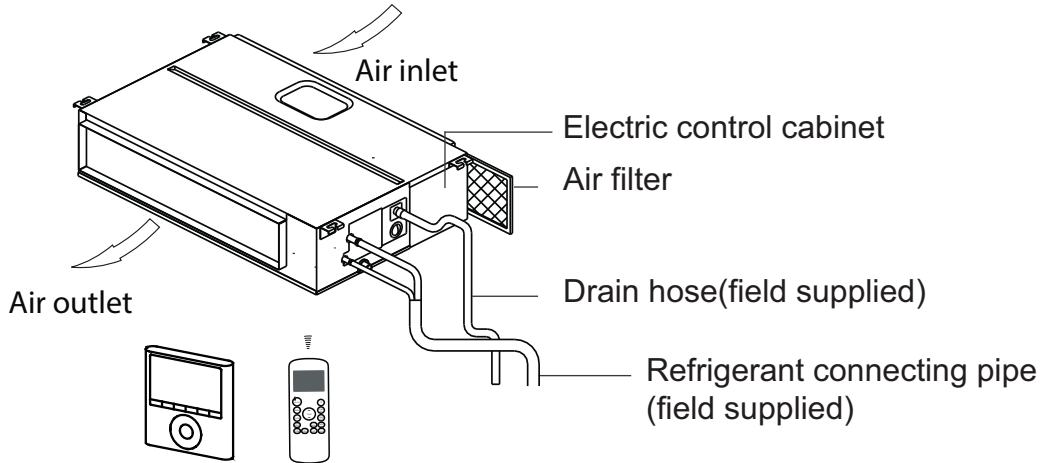

Fig. 3 – Parts List

NOTE: Images are for illustration purposes only.

Notes:

- If the outdoor unit is higher than the indoor unit, prevent rain from flowing into the indoor unit along the connection pipe by creating a downward arc in the connection pipe before it enters the wall to the indoor unit. This ensures that rain drips from the connection pipe before it enters the wall.
- Piping and the interconnecting wiring are field supplied.
- The illustration above is only a sketch. Different models may be slightly different.
- Filter Standard on units produced after serial number 2815V10001

Table 2 lists the units covered in these installation instructions.

Table 2 – Indoor Units

kBTUh	V–Ph–Hz	ID Model No.
9	208/230–1–60	40MBDQ09---3
12		40MBDQ12---3
18		40MBDQ18---3
24		40MBDQ24---3
36		40MBDQ36---3
48		40MBDQ48---3
58		40MBDQ58---3

SYSTEM REQUIREMENTS

Allow sufficient space for airflow and servicing unit. See Fig. 6 for minimum required distances between the unit and the walls or ceilings.

Piping

IMPORTANT: Both refrigerant lines must be insulated separately.

- Minimum refrigerant line length between the indoor and outdoor units is 10 ft. (3 m).
- Table 3 lists the pipe sizes for the indoor unit. Refer to the outdoor unit installation instructions for other allowed piping lengths and refrigerant information.

Table 3 – Piping Lengths

		9K	12K	18K	24K	36K	48K	58K
Gas Pipe (size—connection type)	In. (mm)	3/8 (9.52)	1/2 (12.7)	1/2 (12.7)	5/8 (16)	5/8 (16)	5/8 (16)	3/4 (19)
Liquid Pipe (size—connection type)	In. (mm)	1/4 (6.35)	1/4 (6.35)	1/4 (6.35)	3/8 (9.52)	3/8 (9.52)	3/8 (9.52)	3/8 (9.52)

WIRING

All wires must be sized per NEC (National Electrical Code) or CEC (Canadian Electrical Code) and local codes. Use Electrical Data table MCA (minimum circuit amps) and MOCP (maximum over current protection) to correctly size the wires and the disconnect fuse or breakers respectively.

Sizes 09–24 Recommended Connection Method for Power and Communication Wiring

Power and Communication Wiring:

The main power is supplied to the outdoor unit. The field supplied 14/3 power/communication wiring from the outdoor unit to the indoor unit consists of four (4) wires and provides the power for the indoor unit. Two wires are high voltage AC power, one is communication wiring and the other is a ground wire.

To minimize communication interference: If installed in a high Electromagnetic field (EMF) area and communication issues exist, a 14/2 stranded shielded wire can be used to replace L2 and (S) between outdoor unit and indoor unit – landing the shield onto ground in the outdoor unit only.

Sizes 36–58 Recommended Connection Method for Power and Communication Wiring

Power and Communication Wiring:

The main power is supplied to the outdoor unit. The field supplied power wiring from the outdoor unit to the indoor unit consists of three (3) wires and provides the power for the indoor unit. Two wires are high voltage AC power and one is a ground wire. To minimize voltage drop, the factory recommended wire size is 14/2 stranded with a ground.

Communication Wiring:

A separate shielded stranded copper conductor only, with a 600 volt rating and double insulated copper wire, must be used as the communication wire from the outdoor unit to the indoor unit. Please use a separate shielded 16GA stranded control wire.

CAUTION

EQUIPMENT DAMAGE HAZARD

Failure to follow this caution may result in equipment damage or improper operation.

Wires should be sized based on NEC and local codes.

CAUTION

EQUIPMENT DAMAGE HAZARD

Failure to follow this caution may result in equipment damage or improper operation.

Be sure to comply with local codes while running wire from the indoor unit to the outdoor unit.

Every wire must be connected firmly. Loose wiring may cause the terminal to overheat or result in unit malfunction. A fire hazard may also exist. Ensure all wiring is tightly connected.

No wire should touch the refrigerant tubing, compressor or any moving parts.

Disconnecting means must be provided and shall be located within sight and readily accessible from the air conditioner.

Connecting cable with conduit shall be routed through the hole in the conduit panel.

DIMENSIONS

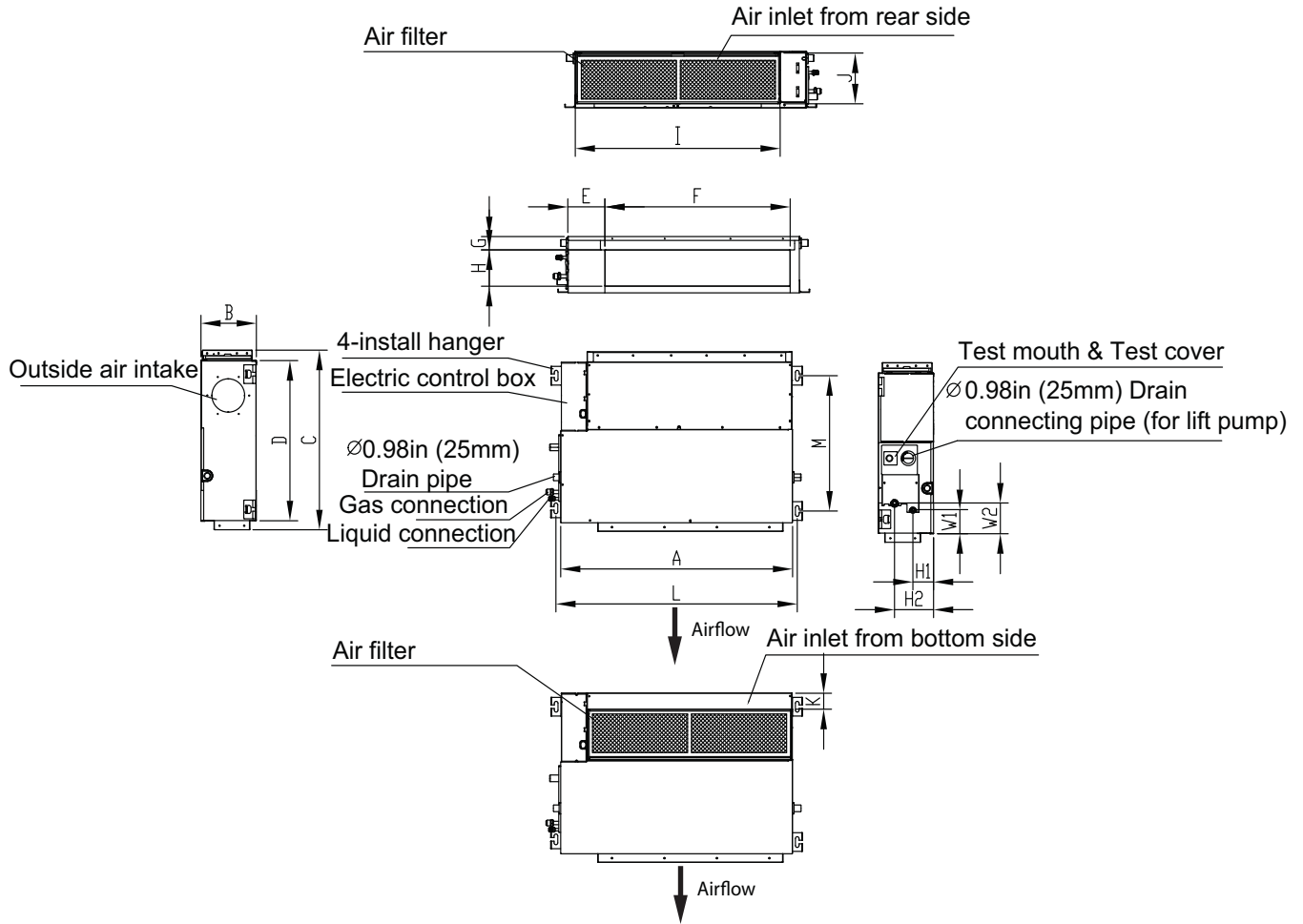

Fig. 4 – Indoor Unit Sizes 09K–48K

Table 4 – Indoor Unit

Size	Unit	OUTLINE DIMENSIONS				AIR OUTLET OPENING SIZE				AIR RETURN OPENING SIZE			HANGER BRACKERS		REFRIGERANT PIPE LOCATIONS				OPERATING WEIGHT lb (kg)
		A	B	C	D	E	F	G	H	I	J	K	L	M	H1	H2	W1	W2	
9	In.	27.6	7.9	19.9	17.7	5.4	21.1	1.2	6	23.6	7.3	2	29.2	14.2	3.3	5.5	3.3	3.3	40
	mm	700	200	506	450	137	537	30	152	599	186	50	741	360	84	140	84	84	18.1
12	In.	27.6	7.9	19.9	17.7	5.4	21.1	1.2	6	23.6	7.3	2	29.2	14.2	3.3	5.5	3.3	3.3	40
	mm	700	200	506	450	137	537	30	152	599	186	50	741	360	84	140	84	84	18.1
18	In.	34.65	8.27	26.54	23.62	5.51	27.80	1.97	5.35	30.79	7.48	1.57	36.22	20	3.07	5.83	3.46	4.41	54
	mm	880	210	674	600	140	706	50	136	782	190	40	920	508	78	148	88	112	24.5
24	In.	43.31	9.8	30.47	27.56	5.51	36.46	1.97	6.89	39.41	8.98	0.2	44.88	23.54	3.15	5.91	5.12	6.1	87
	mm	1100	249	774	700	140	926	50	175	1001	228	5	1140	598	80	150	130	155	39.4
36	In.	53.54	9.8	30.47	27.56	5.51	46.69	1.97	6.89	49.65	8.98	0.2	55.12	23.54	3.15	5.91	5.12	6.1	106
	mm	1360	249	774	700	140	1186	50	175	1261	228	5	1400	598	80	150	130	155	48.3
48	In.	47.24	11.81	34.41	31.5	4.84	41.1	1.97	8.94	43.35	11.02	0.2	48.82	27.44	3.15	5.91	7.28	8.27	120
	mm	1200	300	874	800	123	1044	50	227	1101	280	5	1240	697	80	150	185	210	54.3
58	In.	55.12	17.32	33.78	30.31	4.17	46.81	1.1	15.16	46.54	11.02	1.57	56.57	27.56	8.15	10.75	5.67	5.67	163
	mm	1400	440	858	770	106	1189	28	385	1182	280	40	1437	700	207	273	144	144	74

DIMENSIONS – (CONT)

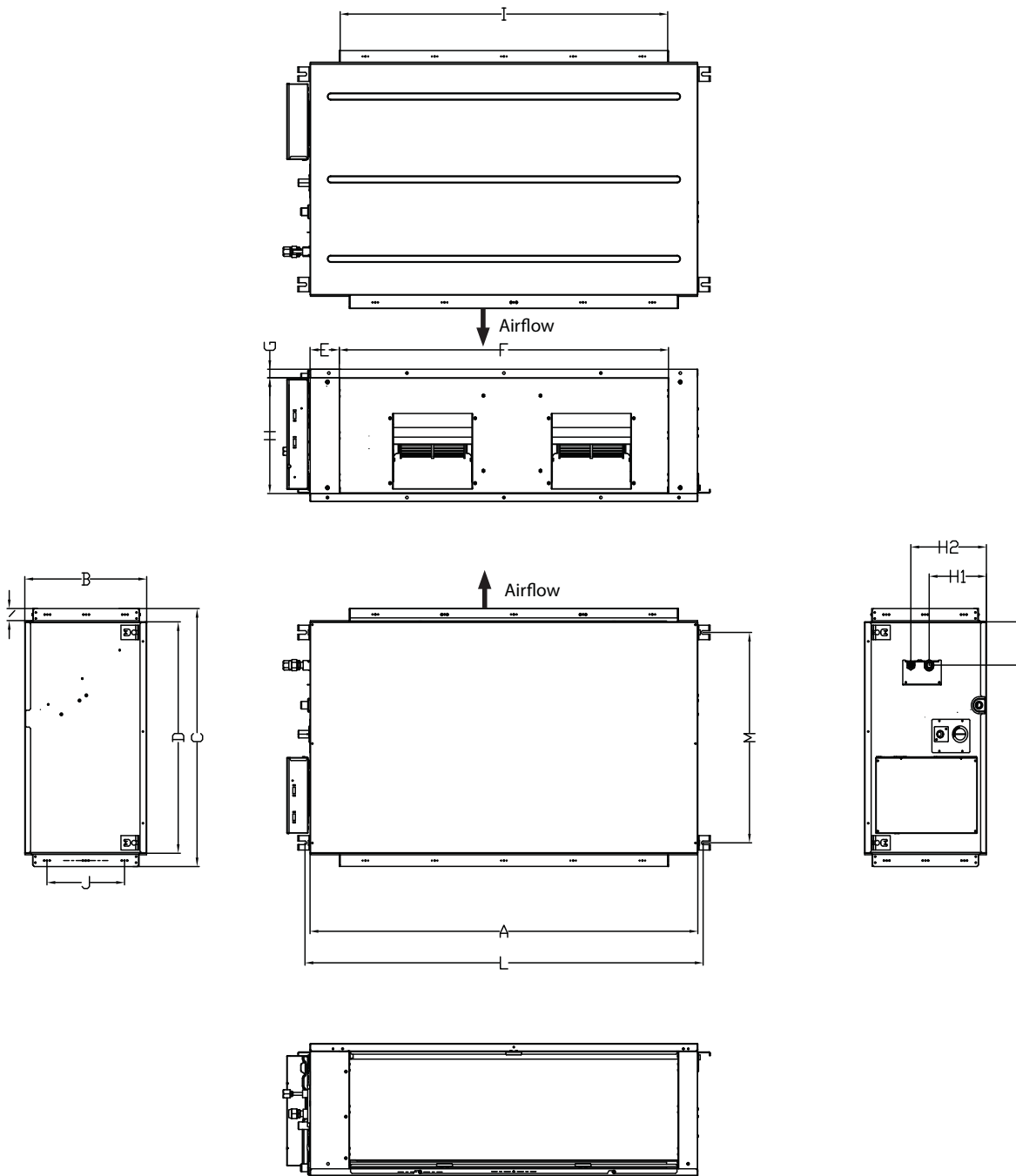

Fig. 5 – Indoor Unit Sizes 58K

INSTALLATION CLEARANCES

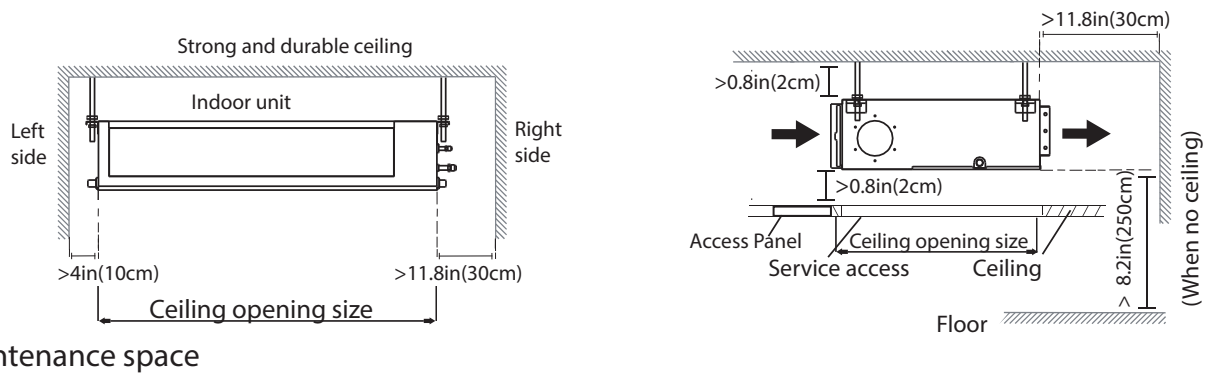

Fig. 6 – Installation Clearances

MAINTENANCE CLEARANCES

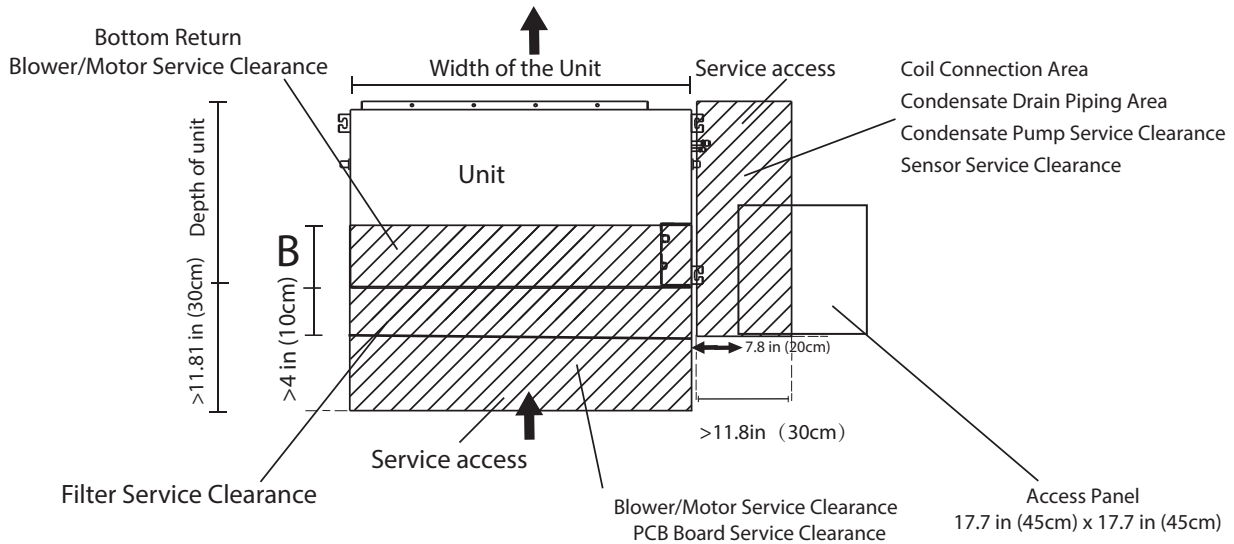

Fig. 7 – Maintenance Clearances

Table 5 – Maintenance Clearances

Capacity (Kbtu)	B
9K	11.81in.(30cm)
12K	11.81in.(30cm)
18K	11.81in.(30cm)
24K	11.81in.(30cm)
36K	11.81in.(30cm)
48K	15.75in.(40cm)
58K	15.75in.(40cm)

NOTE: If installed above a hard lid ceiling, utilize a ceiling access panel the length and width of the unit, otherwise the blower components and/or entire unit cannot be removed.

If a single access panel is desired, the minimum dimensions should be:

- Width: The width of the unit plus 2–inches on both sides
- Length: The length of the unit plus 18–inches on the connection end and 2–inches on the opposite end

INSTALLATION LOCATION REQUIREMENTS

Indoor Unit

- Confirm that the ceiling is able to support the weight of the unit.
- There should be enough room within the false ceiling for installation and maintenance.
- The false ceiling should be horizontal and leveled.
- Install the unit in a location within the room that allows uniform air flow in all directions.
- Do not install the indoor units near a direct source of heat such as direct sunlight or a heating appliance.
- A location which provides appropriate clearances.
- Ensure the hanger is strong enough to withstand the unit's weight.

Indoor and Outdoor Units (General)

- Ensure space is left for access for maintenance.
- Location should be far away from where there is a heat source, leakage of any inflammable, explosive substances, or smog.
- All wiring and refrigerant lines must be at least 3 ft. (1m) away from sources of electromagnetic interference (televisions, radios, etc.). Interference is still possible even if this distance is maintained.
- Do not install the indoor or outdoor units in a location with special environmental conditions. For those applications, contact your Ductless representative.

INDOOR UNIT INSTALLATION

INDOOR DUCTED UNIT INSTALLATION



CAUTION

Be sure that the ceiling grid is supported separately from the unit.

The ceiling grid must not be supported by any part of the unit or any associated wiring or piping work.

MOUNTING THE UNIT

1. **INSTALLING HANGER BOLTS** – Install the hanger bolts at the locations (see Fig. 8, top view). Use a $\varnothing 0.39$ in. / (10mm) all-threaded rod.

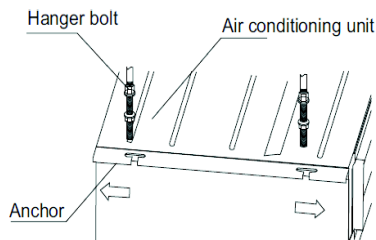

Fig. 8 – Install the Hanger Bolts

2. The unit can now be lifted on to the hanging rods for mounting.
3. Use rods and fasteners to suspend the unit at the factory provided mounting holes.
4. Adjust the unit's height until the bottom is level with the false ceiling, with adequate space to provide enough pitch for the drain.

5. Secure the unit in position with lock nuts and washers on both sides of the mounting bracket. Ensure the threaded rod does not extend more than 2 in. below the mounting brackets (see Fig. 9).

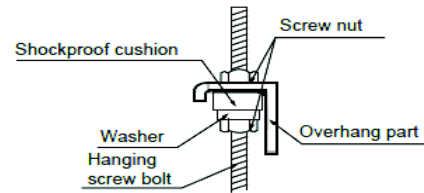

Fig. 9 – Secure the Unit

A150665

RETURN AIR ARRANGEMENT (ONLY SIZES 09–48)

Based on the return air arrangement requirement in the field, the unit can be modified from the rear return to the bottom return.

1. Remove the return Air Return Flange/filter rack and plenum bottom panel.

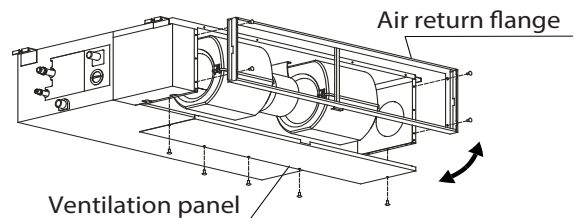

Fig. 10 – Remove the Return Air Return Flange

2. Install the Seal Sponge on the bottom inlet.
3. Swap the position to change the rear return to bottom return arrangement installing the Air Return flange and the filters.

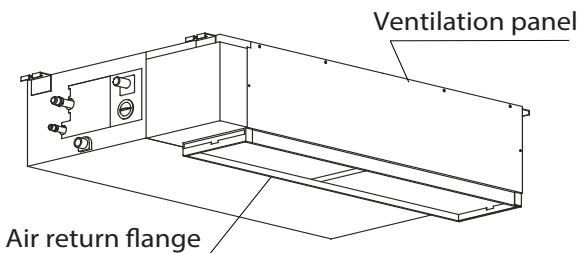

Fig. 11 – Change the Rear Return

4. Install the filter brackets to lock the filter in place.

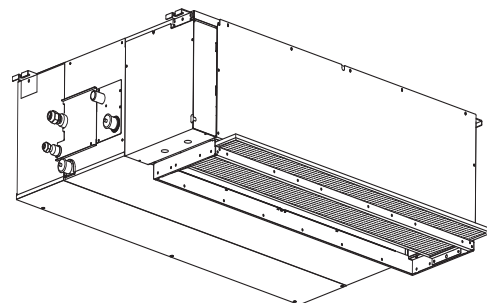
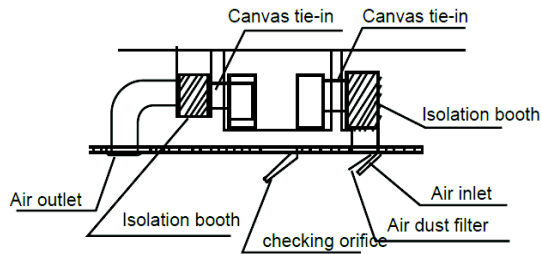

Fig. 12 – Install the Filter Brackets

INSTALLING DUCTWORK

Connect the return and supply ducts to the duct collars provided on the unit. Adequate distance between the return and supply diffusers should be maintained to avoid short circulation of air within the space.

The filter is located on the return side of the unit, on the rear or bottom depending on the return air inlet arrangement.



A150671

Fig. 13 – Installing Duct

OUTSIDE AIR CONNECTION

If necessary, an outside air connection knockout is located on the side of the unit downstream of the air filter. It is recommended to field supply and field install a booster fan on the duct work used for outside air. A booster fan may be powered by the connection on the PCB board CN43. The maximum input for the motor is 200W. The output of the NEW FAN will be active while the indoor fan is active.

NOTE: The amount of outside air is dependent on different factors as the booster fan, outside air duct work type and length, static pressure, conditions, etc..

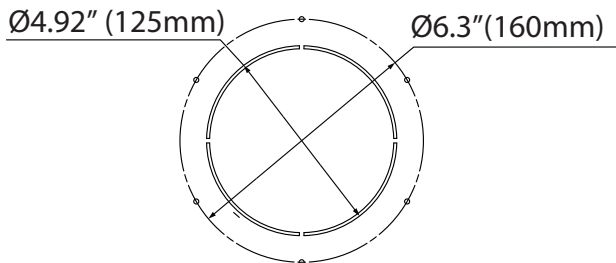
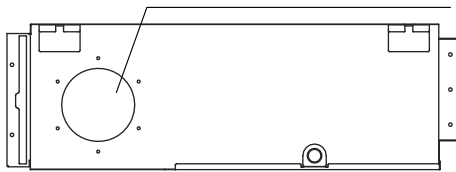

Fig. 14 – Outside Air Connection

CONDENSATE PIPE INSTALLATION

The unit is supplied with a 1 1/4-in. OD drain connection to connect copper or PVC drain piping. When installing condensate piping, follow these recommendations:

- Install drains to meet local sanitation codes.
- The Ducted Style Indoor unit is supplied with a condensate lift pump that is capable of lifting water 29.5in. (750mm).
- The highest point in the condensate piping should be as close to the unit as possible (see Fig. 17).
- Condensate piping should slope downward in the direction of condensate flow, with a minimum gradient of 1/100.
- When multiple units are connected to a common condensate drain, ensure the drain is large enough to accommodate the volume of condensate from all units. It is also recommended to have an air vent in the condensate piping to prevent air lock.

- Condensate piping must not be installed where it may be exposed to freezing temperatures.
- To prevent the pipe from sagging, space hanging wires every 39–59in. (1–1.5m).
- If the outlet of the drainpipe is higher than the body's pump joint, provide a lift pipe for the exhaust outlet of the indoor unit. The lift pipe must be installed no higher than 21.7in. (55cm) from the ceiling board. The distance between the unit and the lift pipe must be less than 7.9in (20cm). Incorrect installation could cause water to flow back into the unit and flood.
- To prevent air bubbles, keep the drain hose level or slightly tiled up <3in. (75mm).
 1. Cover the drain hose with heat insulation to prevent condensation and leakage.
 2. Attach the mouth of the drain hose to the unit's outlet pipe. Sheath the mouth of the hose and clip it firmly with a pipe clasp (see Fig. 15).

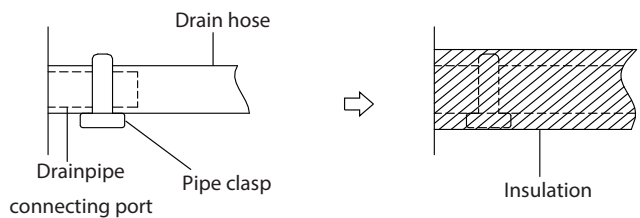

Fig. 15 – Indoor Drainpipe Installation

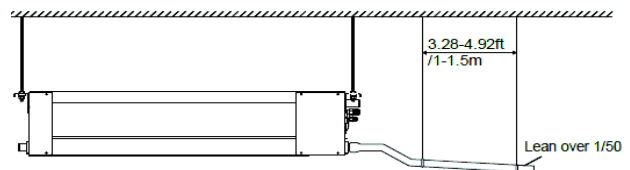

Fig. 16 – Condensate piping without a pump

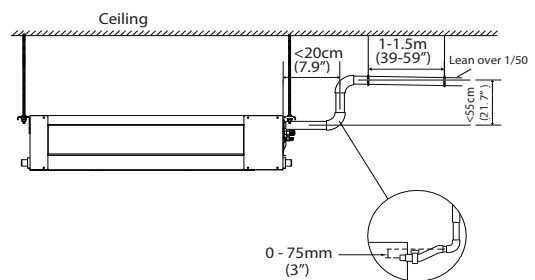

Fig. 17 – Condensate piping with a pump

When connecting multiple drainpipes, install the pipes as illustrated on Fig. 18.

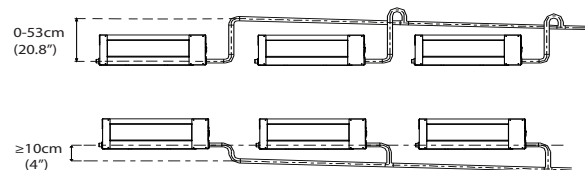

Fig. 18 – Connecting Multiple Drain Pipes

CONDENSATE DRAIN AND CONDENSATE LIFT PUMP INSTALLATION (HORIZONTAL INSTALLATION)

For sizes 9, 12 and 18, the condensate lift pump has been provided in a separate box. Use the following steps to install the External Condensate Lift pump for a Horizontal Installation of the indoor unit.

NOTE: Drain connections A, B and C are covered with caps.

- (1.) For sizes 09 and 12
 - a. Remove the cap on the drainage outlet.
 - b. Cut both ends of the rubber tubing provided into a straight one.
 - c. Connect the drainage outlet and condensate lift pump using the rubber tubing and secure it with clamps on both ends, as shown on Figure 19.
 - d. Plug the power cable of the external pump to CN13 / "PUMP" pin and plug the water level sensor cable to the CN5 / "WATER" to enable the pump (see Fig. 23).
- (2.) For size 18
 - a. Remove the cap on drain connector B.
 - b. Connect the drain connector B and the condensate lift pump using the L rubber hose and secure it with clamps on both ends.
 - c. Connect the drainpipe to the connector D (see Fig. 20).
 - d. Plug the power cable of the external pump to CN13 / "PUMP" pin and plug the water level sensor cable to the CN5 / "WATER" to enable the pump (see Fig. 23).

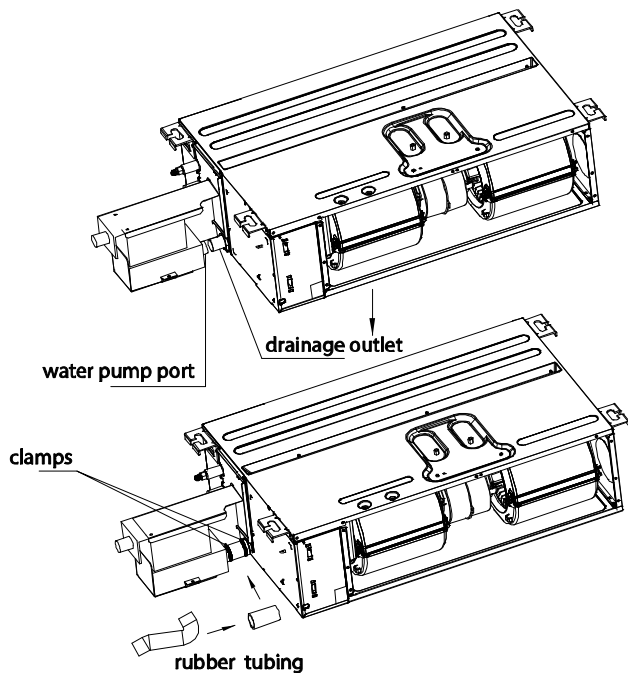

Fig. 19 – Condensate lift pump installation sizes 09–12

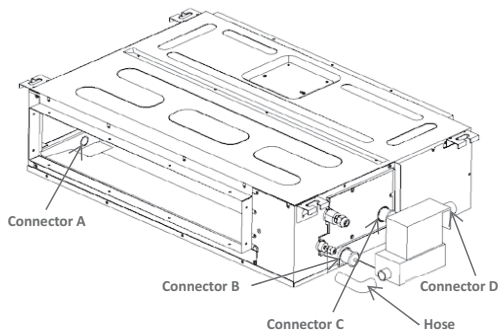

Fig. 20 – Condensate lift pump installation size 18

- (3.) Sizes 24, 36, 48 and 58 have a built-in condensate lift pump. The drain connections (A, B and C) are covered with caps.
 - a. Connect the drainpipe to connector D (see Fig. 21).

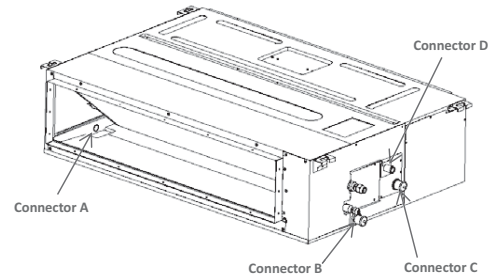

Fig. 21 – Connection of drain pipe to condensate lift pump sizes 24–58

VERTICAL INSTALLATION

Disable the Condensate Lift Pump

The pump must be disabled while the unit is installed vertically (up flow) or the lift pump assembly is removed from its original position:

- Open the cover of the E-Parts Box assembly, unplug the "PUMP" pin to disable the pump function, and short connect the "CN5" plug to disable the water level sensor (see Fig. 22 and Fig. 23).

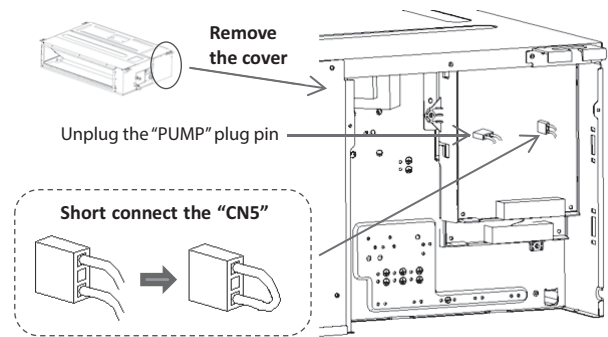

Fig. 22 – Unplug the PUMP Pin



Fig. 23 – Condensate Lift Pump Connectors

Remove the cap from connector C and connect the condensate drain pipe to drain connector C. (see Fig. 25).

NOTE: For size 18, the External Condensate lift pump should be removed (see Fig. 24).

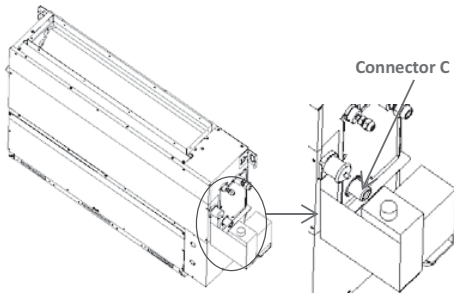

Fig. 24 – Sizes 9, 12, 18 with External Condensate Lift Pump

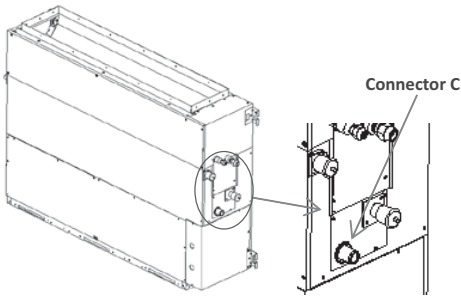

Fig. 25 – Sizes 24 to 48 with Built-in Condensate Lift Pump

DRAINAGE TEST FOR UNITS WITHOUT A CONDENSATE LIFT PUMP

Check that the drainpipe is unhindered. Fill the drain pan with 0.5 gallons (2 liter) of water.

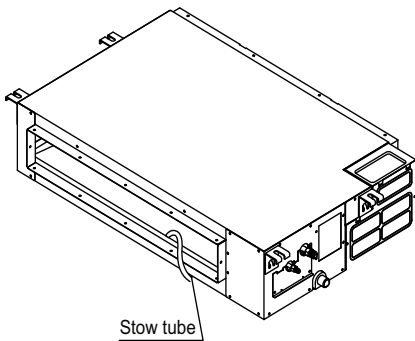
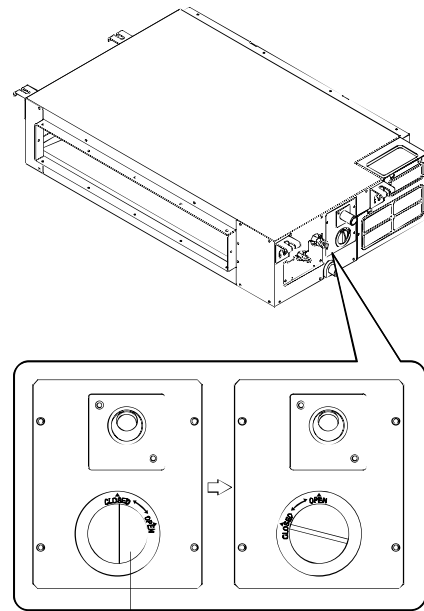

Fig. 26 – Units without a Pipe

CONDENSATE LIFT PUMP AND DRAINAGE TEST

Follow these steps to perform the test:

1. Remove the test cover by rotating it counter-clockwise as shown in Fig. 27.
2. Using a piece of tubing or pipe, fill the condensate lift pump reservoir with 70 oz. of water (see Fig. 28).
3. Turn the unit **ON** in cooling mode. The condensate lift pump comes on. Watch the end of the drain pipe for any water. It may take some time for the water to travel, depending on the length of the drain pipe.
4. During this test, check all bends or joints for leakage.



TEST COVER
Fig. 27 – Check the Bends and Joints for Leakage

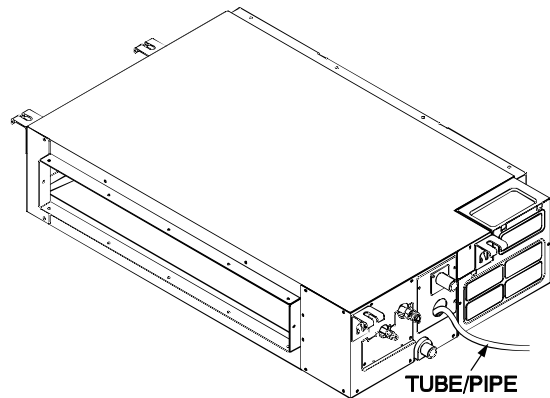

Fig. 28 – Tube/Pipe Insert

A150675

Condensate Lift Pump Maintenance

1. Remove the four screws from the drain pump (sizes 24 to 48).
2. Unplug the pump power supply and water level switch cable.
3. Detach the pump.

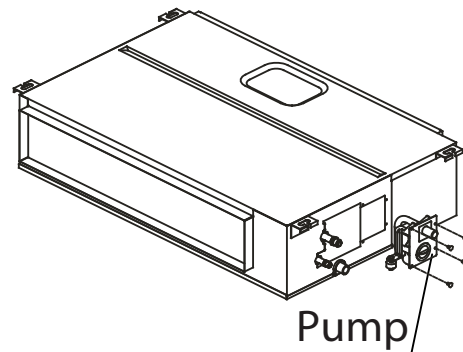

Fig. 29 – Detach the Pump

EXTERNAL STATIC PRESSURE

Using the KSACN0501AAA Wired Controller, the external static pressure can:

- Be manually changed to the fan curves SP2, SP3, SP4.
- Choose the Automatic Airflow “AF” adjustment function which will automatically identify the static pressure and regulate the amount of airflow.

Follow instructions to configure:

1. Make sure the test run is done with a dry coil. If the coil is not dry, run the unit for 2 hours in **FAN ONLY** mode to dry the coil.
2. Check that both the power supply wiring and the duct installation have been completed. Check that any closing dampers are open. Check that the air filter is properly attached to the air return side passage of the unit.
3. If there is more than one air inlet and/or outlet, adjust the dampers so that the airflow rate of each air inlet and outlet conforms with the designed airflow rate. Ensure the unit is in **FAN ONLY** mode. Press and set the airflow adjustment button on the remote control to change the airflow rate from H or L. Turn the indoor unit **OFF**.
4. Set the parameters for airflow adjustment. When the system is **OFF**, perform the following steps.
 - a. Press and hold **COPY** for approximately 4 seconds.
 - b. Press “+” or “-” to scroll through the menu and make a selection, either SP or AF.

NOTE: T1, T2, T26, T3, T4 are sub-menus for thermistors. Do not select for setting external static pressure.

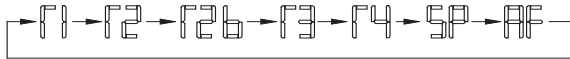

Fig. 30 – Wired Controller Menu Selection

- (1.) If setting the external static pressure manually, select **SP** and press **CONFIRM**. Select the SP number (SP1, SP2, SP3, SP4 – see static pressure Table 6 and curves (Figs. 32 through 38)). Power down the unit to lock in the selection.
- (2.) If choosing the automatic airflow adjustment function, select **AF** and press **CONFIRM**. The system will start the fan for airflow automatic adjustment. **ON** will flash when the fan is running during the Automatic Airflow adjustment. After 3 to 6 minutes the system stops operating once the automatic airflow adjustment has finished.

ON will flash when the fan is running during the automatic airflow adjustment.

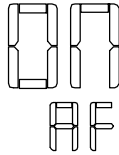

Fig. 31 – Automatic Airflow ON signal



CAUTION

DAMPERS

DO NOT adjust the dampers when the automatic airflow adjustment is active.



CAUTION

AIRFLOW ADJUSTMENT

- If there is no charge after the airflow adjustment in the ventilation paths, be sure to reset the automatic airflow adjustment.
- If there is no charge to the ventilation paths after the airflow adjustment, contact your dealer, especially if this occurs after testing the outdoor unit or if the unit has been moved to a different location.
- Do not use the automatic airflow adjustment with the remote control, if you are using booster fans, outdoor air processing unit, or a HRV via duct.
- If the ventilation paths have been changes, reset airflow automatic adjustment as described from step 3 onwards.

FAN PERFORMANCES AT VARYING STATIC PRESSURES

Table 6 – Static Pressure at the Rated Point and Static Pressure Range

Size	Units	Static Pressure at Rated Point				Static Pressure Range
		SP1	SP2	SP3	SP4	
9	In. WG	0.068	0.104	0.128	0.176	0~0.20
	Pa	17	26	32	44	(0~50)
12	In. WG	0.064	0.10	0.136	0.20	0~0.20
	Pa	16	25	34	50	(0~50)
18	In. WG	0.096	0.168	0.288	0.392	0~0.40
	Pa	24	42	72	98	(0~100)
24	In. WG	0.10	0.216	0.336	0.528	0~0.64
	Pa	25	54	84	132	(0~160)
36	In. WG	0.168	0.312	0.48	0.62	0~0.64
	Pa	42	78	120	155	(0~160)
48	In. WG	0.18	0.404	0.616	0.64	0~0.64
	Pa	45	101	154	160	(0~160)
58	In. WG	.296	0.416	.584	0.8	0~0.80
	Pa	74	104	146	200	(0~200)
Factory Setting		√				

Table 7 – Airflow at Rated Point

System Size		Airflow at Rated Point						
		9	12	18	24	36	48	58
High	CFM	353	353	529	776	1,082	1,229	2,157
	CMH	600	600	900	1,320	1,840	2,090	3,665
Medium	CFM	282	282	450	694	912	1,032	1,710
	CMH	480	480	765	1,180	1,550	1,755	2,906
Low	CFM	176	176	370	435	703	715	1,262
	CMH	300	300	630	740	1,195	1,215	2,145

FAN PERFORMANCES AT VARYING STATIC PRESSURES (CONT)

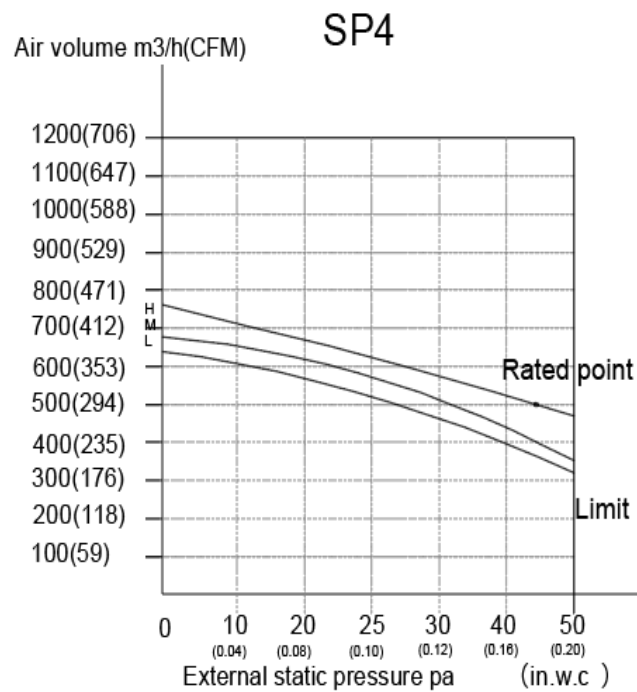
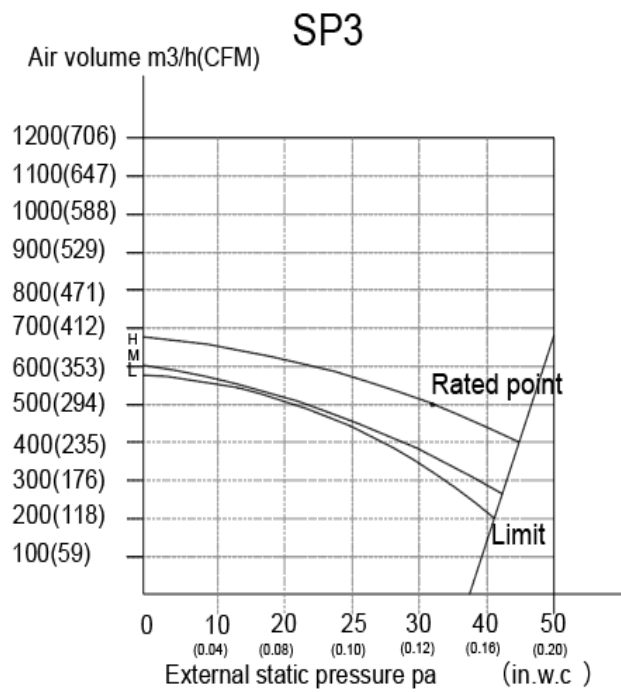
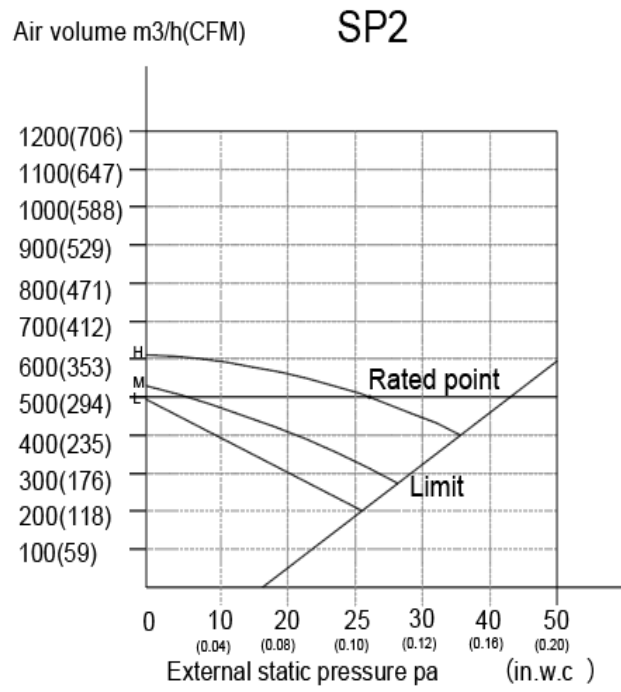
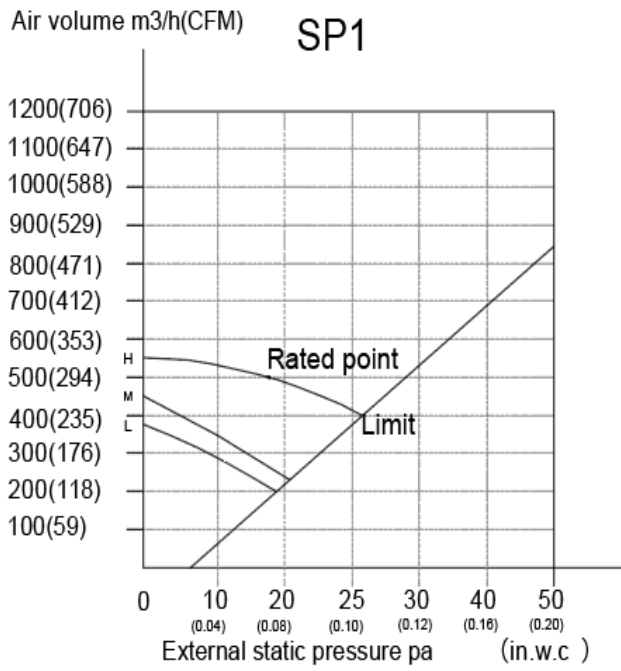
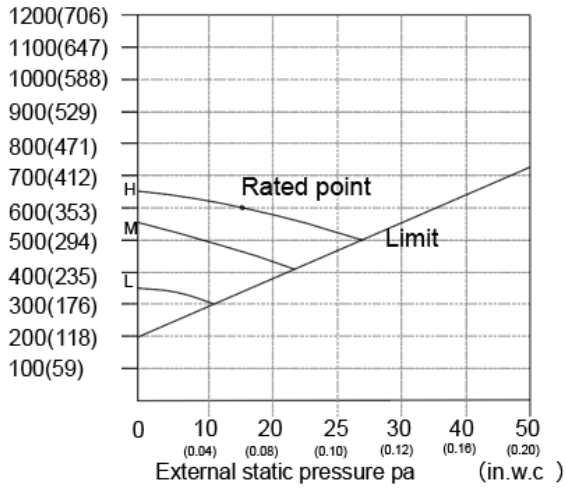

Fig. 32 – Fan Performance – 40MBDQ09

FAN PERFORMANCES AT VARYING STATIC PRESSURES (CONT)

Air volume m3/h(CFM)

SP1



Air volume m3/h(CFM)

SP2

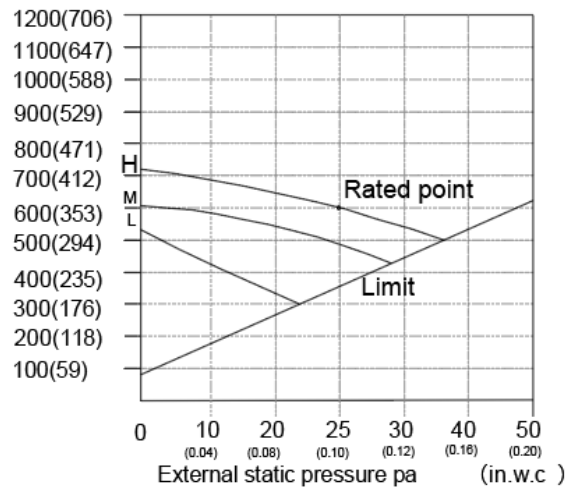

Air volume m3/h(CFM)

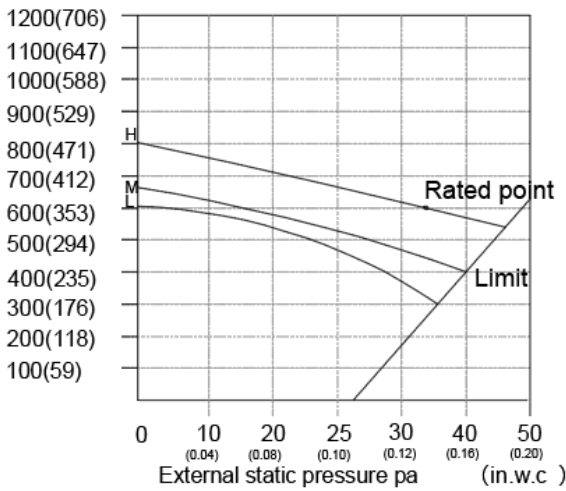

Air volume m3/h(CFM)

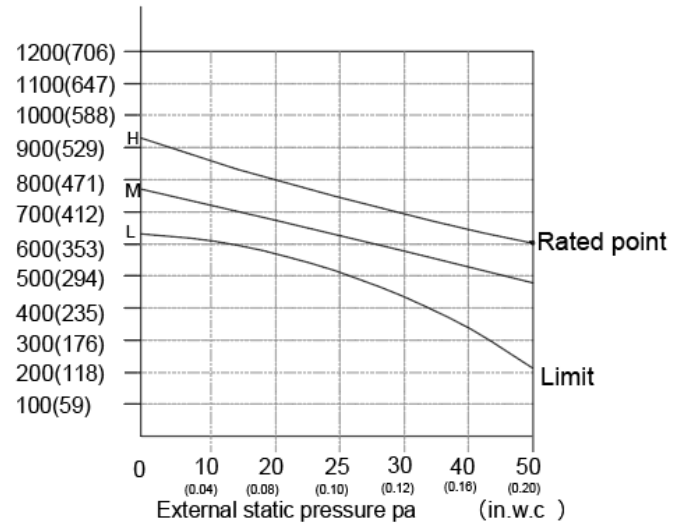

Fig. 33 – Fan Performance – 40MBDQ12

FAN PERFORMANCES AT VARYING STATIC PRESSURES (CONT)

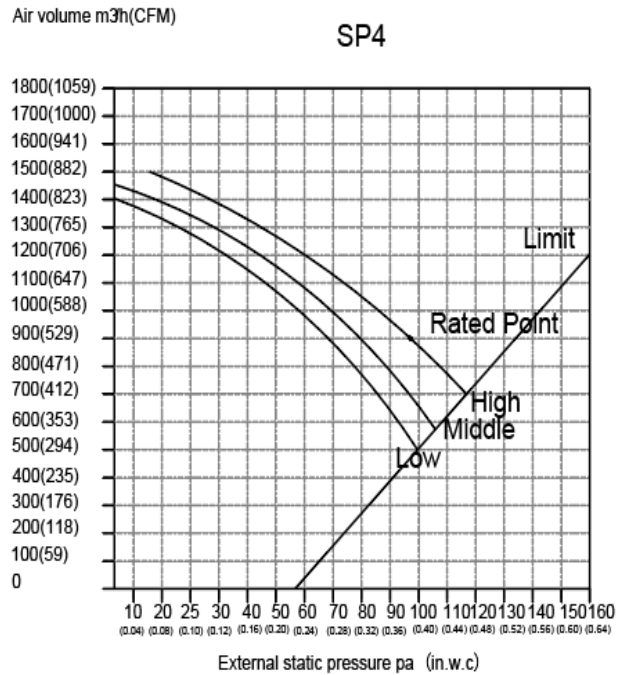
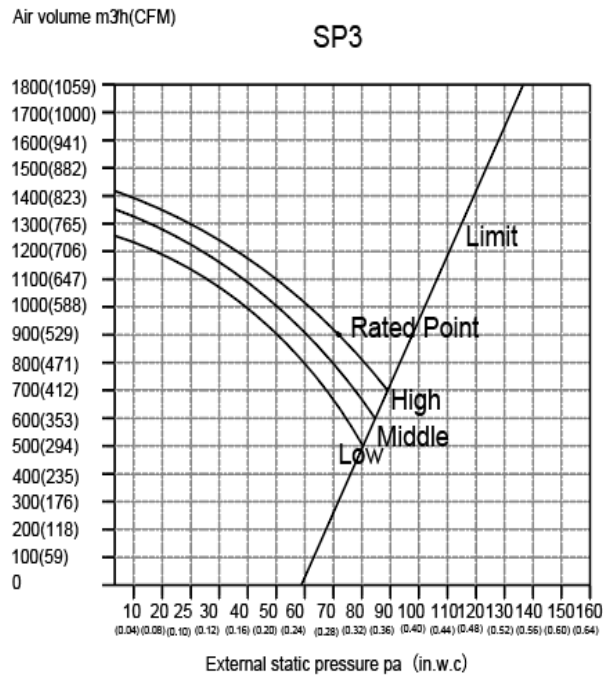
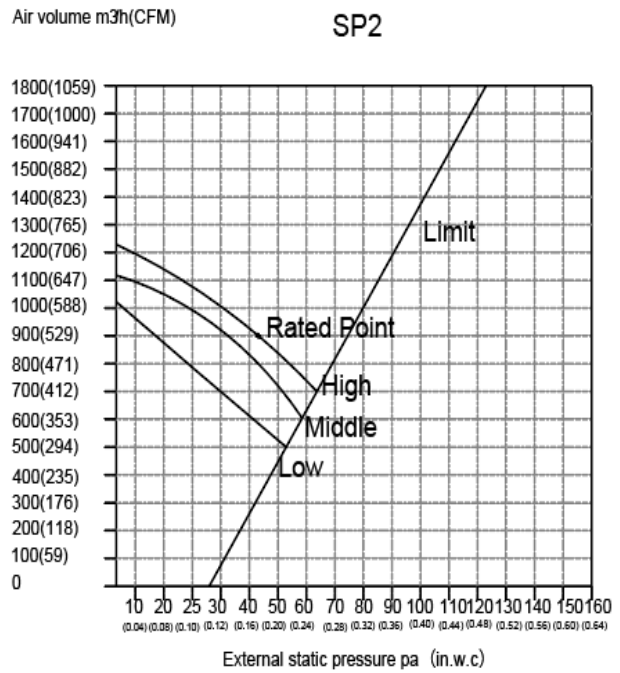
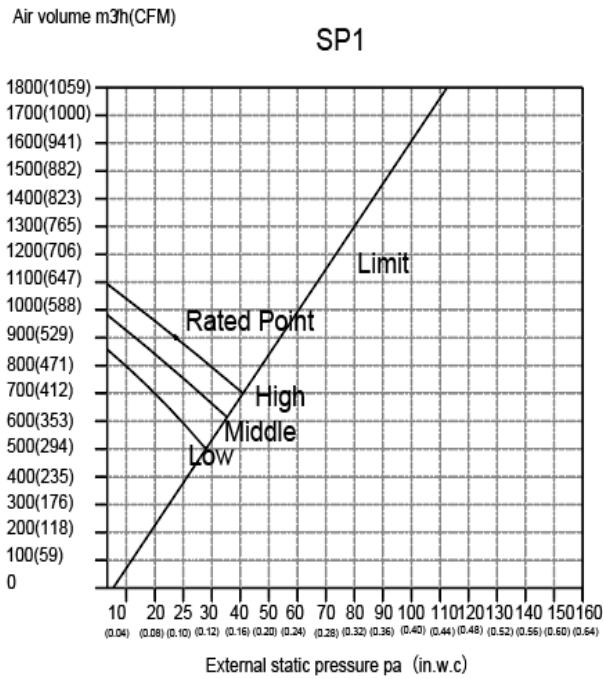

Fig. 34 – Fan Performance – 40MBDQ18

FAN PERFORMANCES AT VARYING STATIC PRESSURES (CONT)

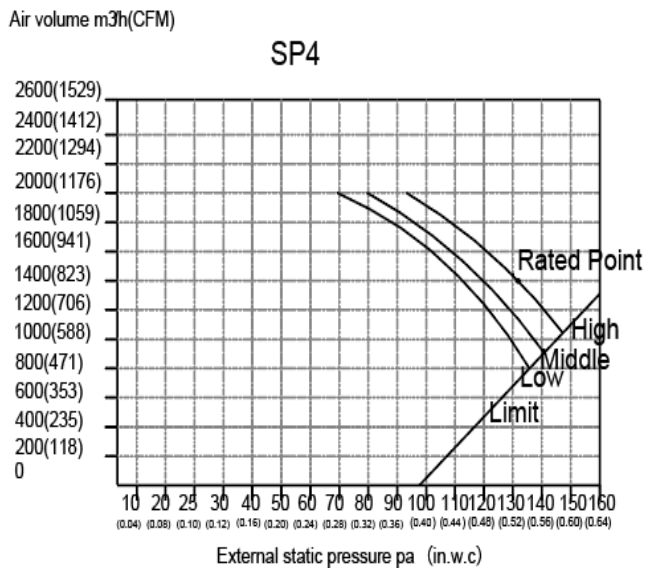
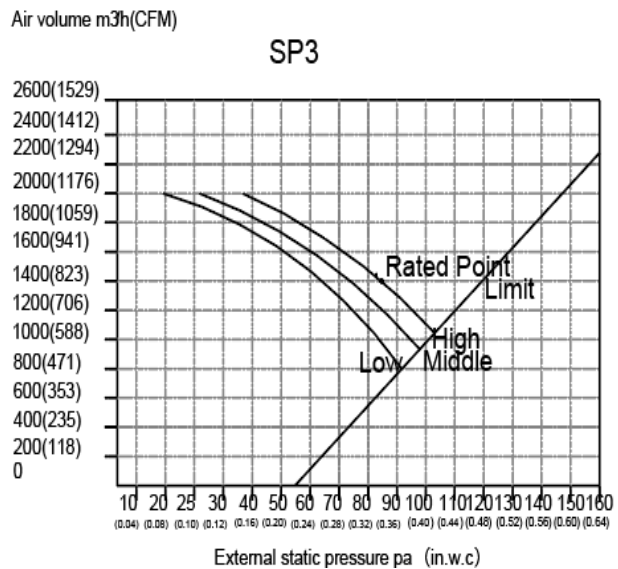
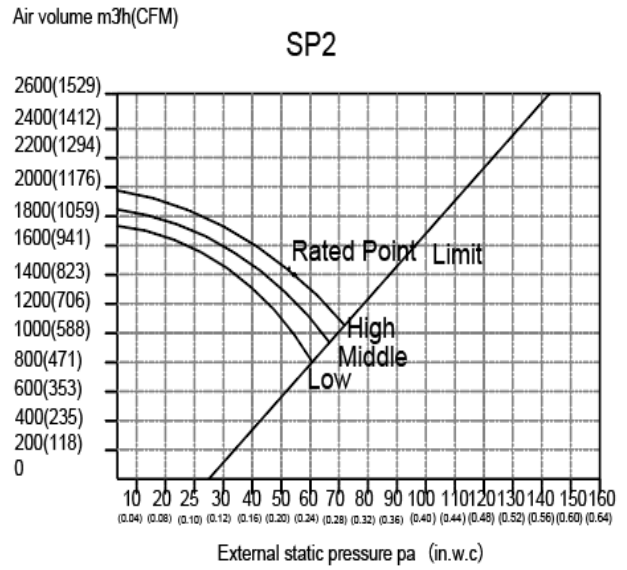
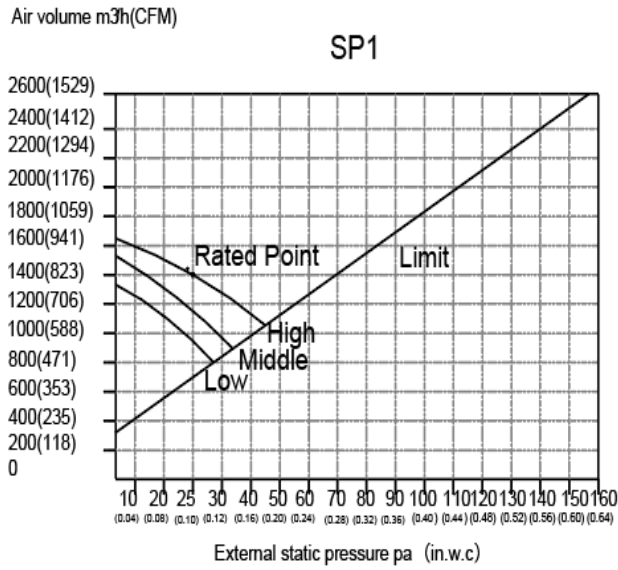

Fig. 35 – Fan Performance – 40MBDQ24

FAN PERFORMANCES AT VARYING STATIC PRESSURES (CONT)

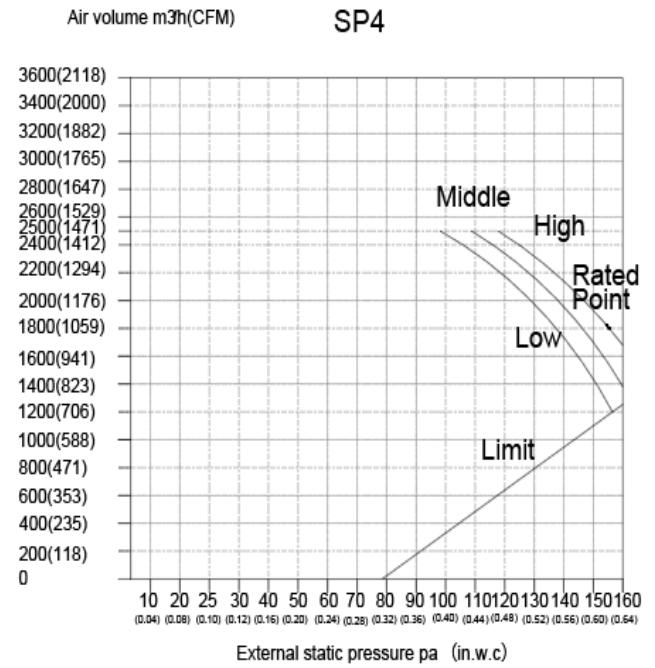
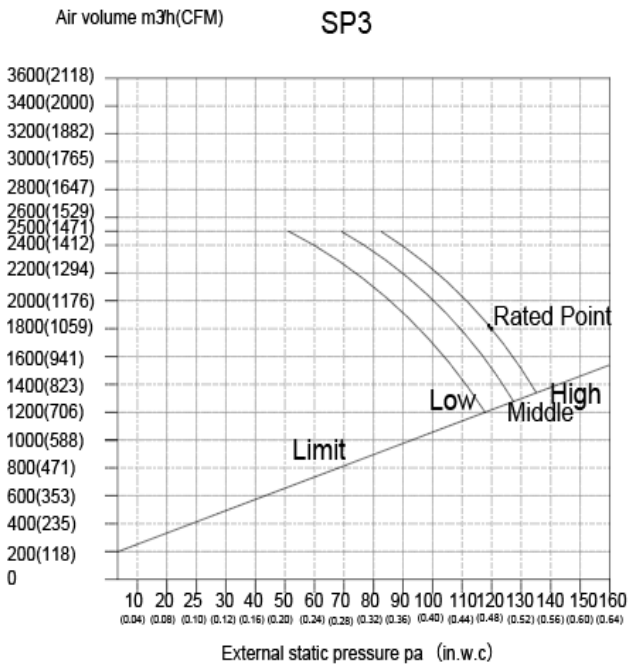
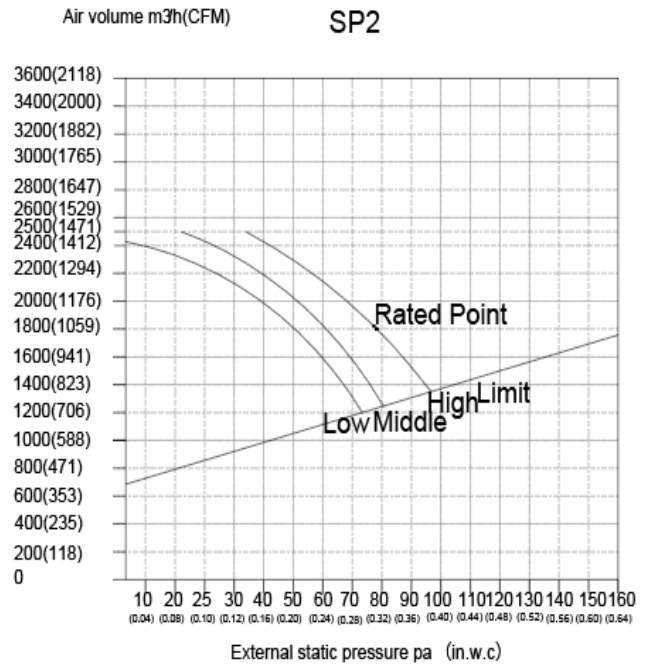
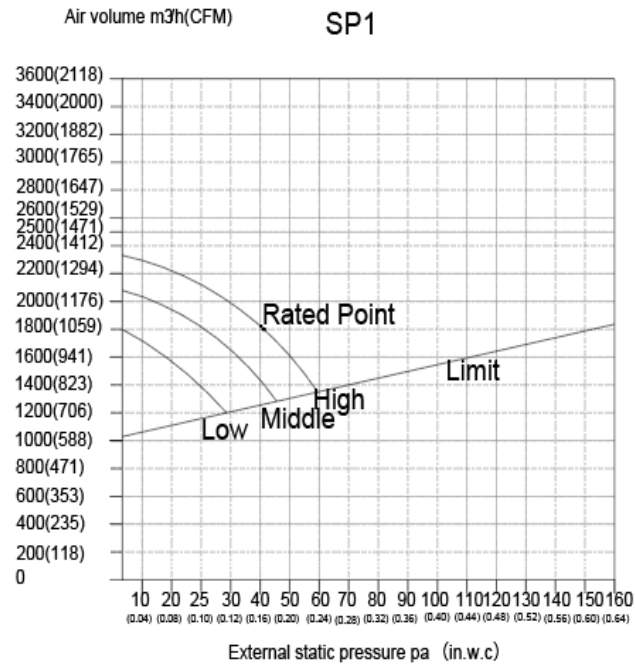

Fig. 36 – Fan Performance – 40MBDQ36

FAN PERFORMANCES AT VARYING STATIC PRESSURES (CONT)

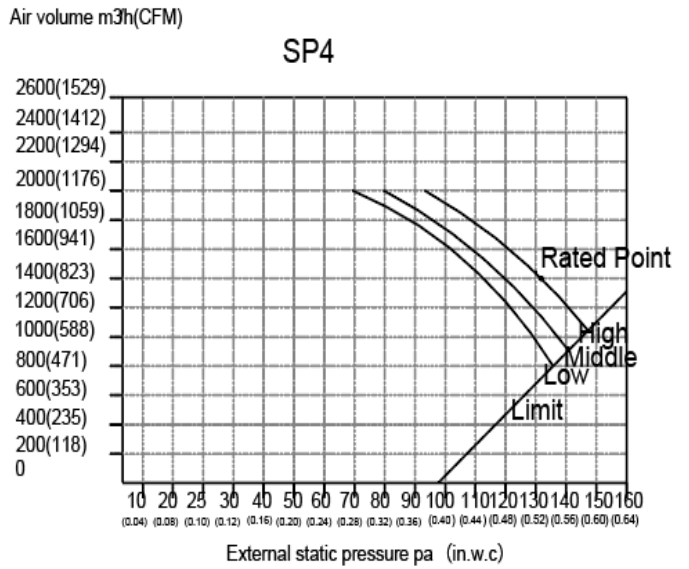
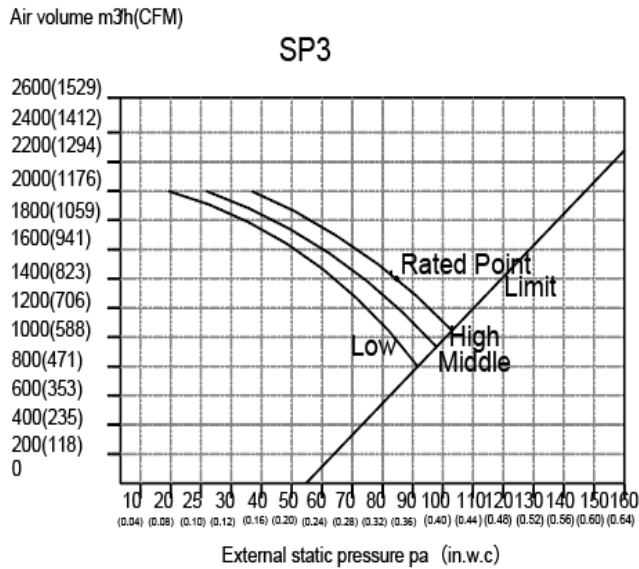
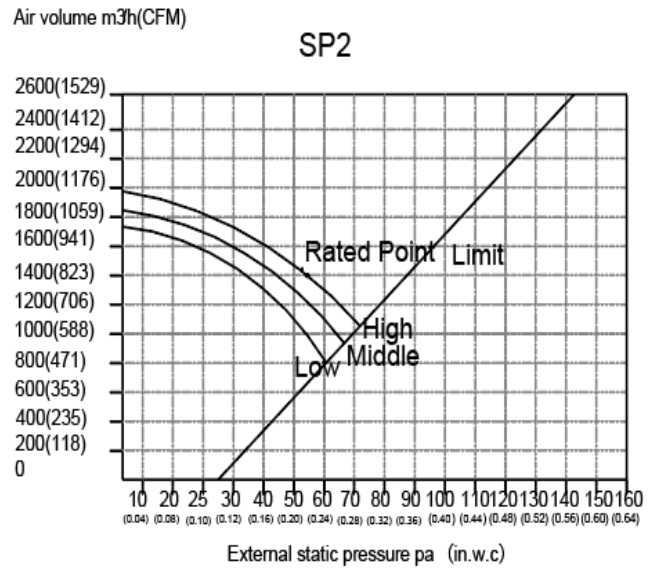
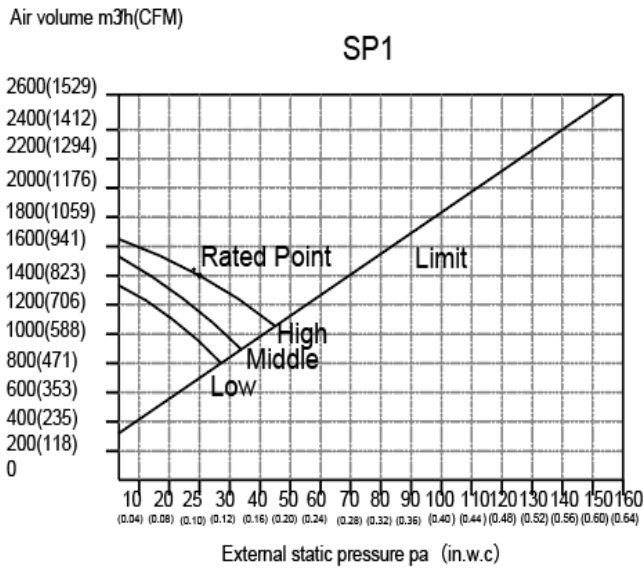

Fig. 37 – Fan Performance – 40MBDQ48

FAN PERFORMANCES AT VARYING STATIC PRESSURES (CONT)

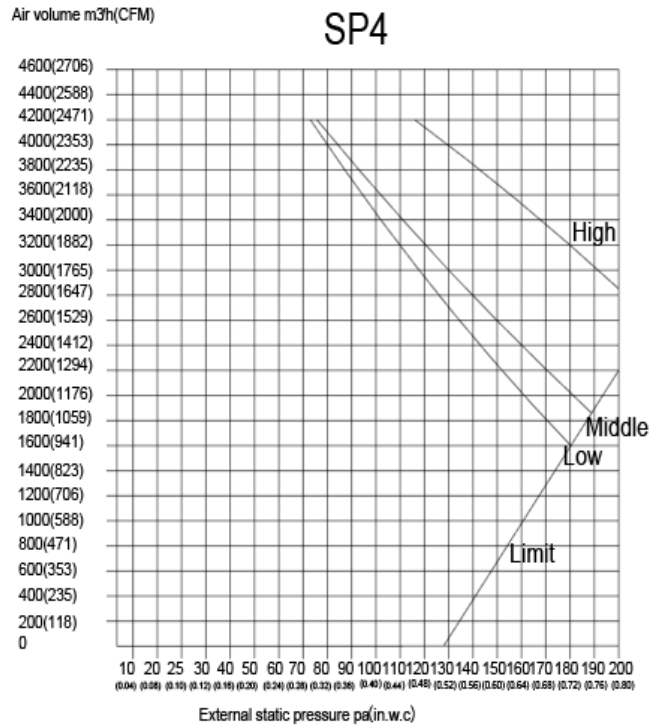
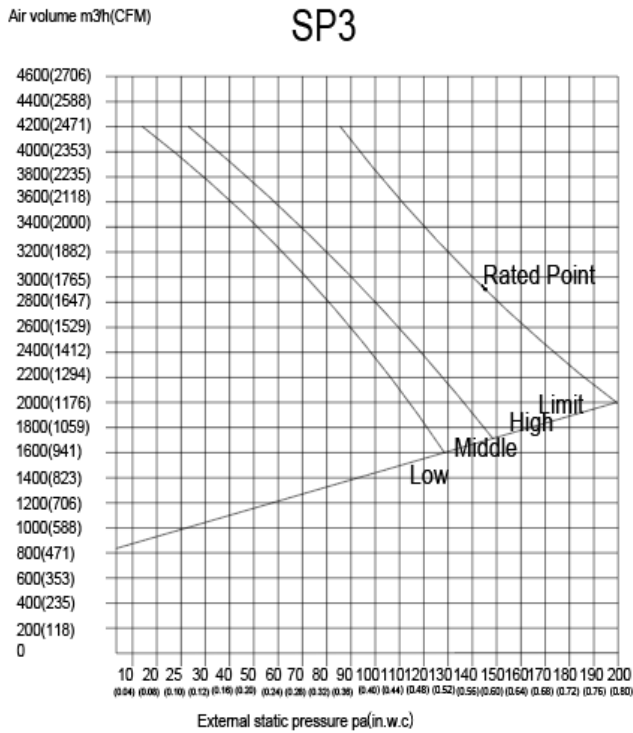
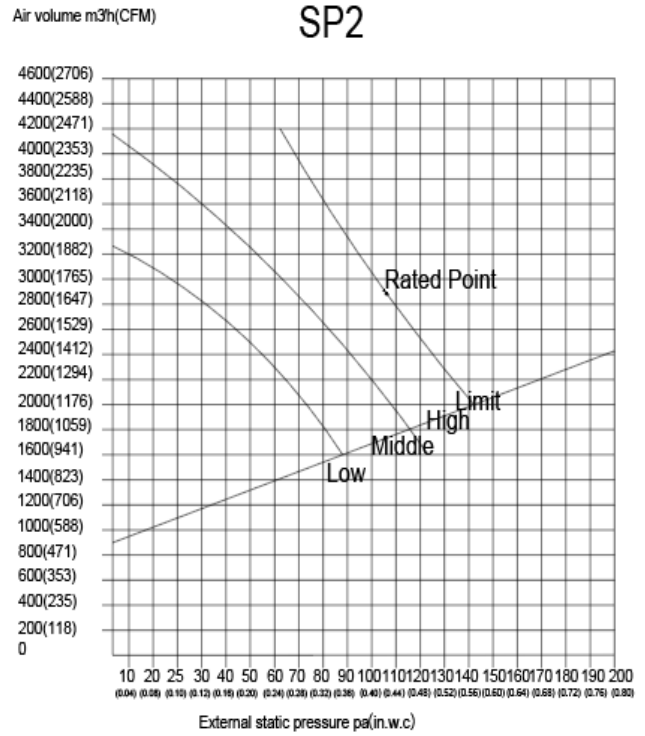
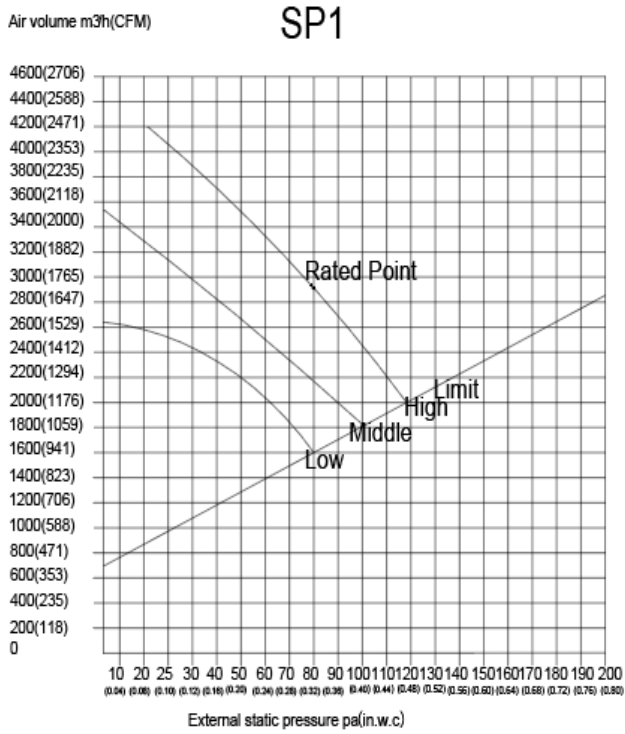

Fig. 38 – Fan Performance – 40MBDQ58

ELECTRICAL DATA

Table 8 – Electrical Data

UNIT SIZE	INDOOR FAN				MAX FUSE CB AMP
	V-PH-HZ	FLA	HP	W	
09	208-230/1/60	1.11	0.18	130	Refer to outdoor unit installation instructions – Indoor unit powered by the outdoor unit
12		1.11	0.18	130	
18		1.2	0.27	200	
24		1.2	0.27	200	
36		2.45	0.56	420	
48		3.2	0.75	560	
58		3.65	0.952	1000	

LEGEND

FLA – Full Load Amps

CONNECTION DIAGRAMS

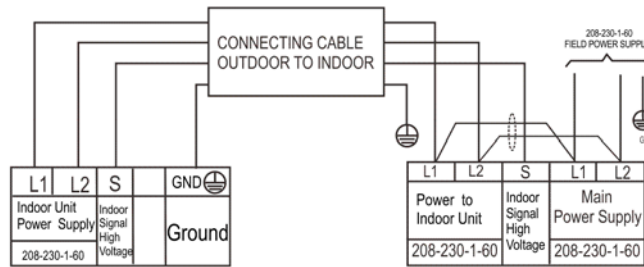

Fig. 39 – Connection Diagrams (sizes 09 to 24)

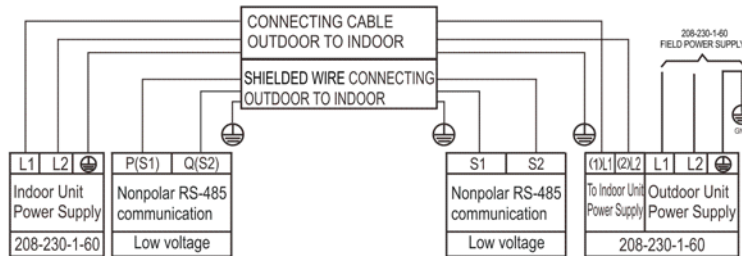

Fig. 40 – Connection Diagrams (sizes 36 and 58)

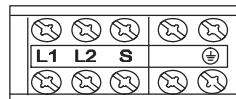

Fig. 41 – Control and Power Wiring on Indoor Unit (sizes 09 to 24)

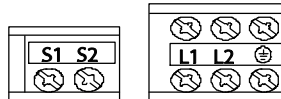

Fig. 42 – Control and Power Wiring on Indoor Unit (sizes 36 to 58)

Notes:

1. Do not use thermostat wire for any connection between indoor and outdoor units.
2. All connections between indoor and outdoor units must be as shown. The connections are sensitive to polarity and will result in a fault code.

INSTALL ALL POWER, INTERCONNECTING WIRING, AND PIPING TO INDOOR UNIT

1. Run interconnecting piping and wiring from the outdoor unit to the indoor unit.
2. Connect wiring from outdoor unit per the connection diagram (see Fig. 39 and Fig. 40).
3. Replace field wiring cover of the indoor unit.

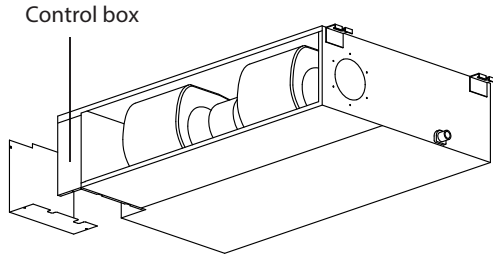

Fig. 43 – Control Box

4. Connect refrigerant piping and drain line outside of indoor unit. Complete pipe insulation at flare connection then fasten the piping and wiring to the wall as required. Completely seal the hole in the wall.
5. Piping:
 - c. Cut the pipe, with a pipe cutter, at 90 degrees (see Fig. 44).
 - d. Remove the service connection, if provided with the unit.

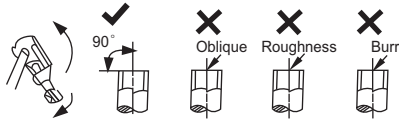

Fig. 44 – Pipe Cutting

- e. Remove all the burrs from the cut cross section of the pipe avoiding any burrs inside the tubes.
- f. Remove the flare nuts attached to the indoor and outdoor units.
- g. Install the correct size flare nut onto the tubing and make the flare connection. Refer to Table 9 for the flare nut spaces.

Table 9 – Flare Nut Spacing

OUTER DIAM. (mm)	A (mm)	
	Max.	Min.
Ø 1/4" (6.35)	0.05 (1.3)	0.03 (0.7)
Ø 3/8" (9.52)	0.06 (1.6)	0.04 (1.0)
Ø 1/2" (12.7)	0.07 (1.8)	0.04 (1.0)
Ø 5/8" (15.88)	0.09 (2.2)	0.08 (2.0)

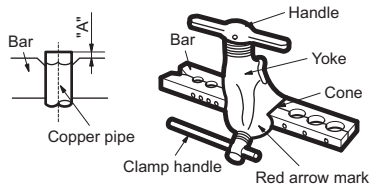

Fig. 45 – Flare Nut Spacing

A150768

- h. Apply a small amount of refrigerant oil to the flare connection on the tubing.
- i. Align center of the pipes and/or service valve.

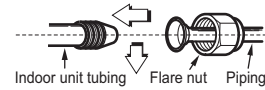

Fig. 46 – Align Pipe Center

A150769

- j. Connect both the liquid and gas piping to the indoor unit.
- k. Tighten the flare nut using a torque wrench as specified in Table 10.

Table 10 – Tightening Torque

PIPE DIAMETER INCH (mm)	TIGHTENING TORQUE	
	Ft-lb	N-m
Ø1/4" (6.35)	10 to 13	13.6 to 17.6
Ø3/8" (9.52)	24 to 31	32.5 to 42.0
Ø1/2" (12.7)	37 to 46	50.1 to 62.3
Ø5/8" (15.88)	50 to 60	67.7 to 81.3

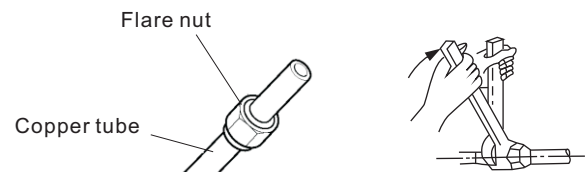

Fig. 47 – Tighten the Flare Nut

A150770

6. Connect the drain line. The drain line must not have a trap anywhere in its length, must pitch downwards, and must be insulated up to the outside wall.

NOTE: For applications where gravity cannot be used for drainage, a condensate pump accessory is available. Consult the condensate pump Installation Instructions for more information.

WIRELESS REMOTE CONTROL INSTALLATION

Mounting Bracket (if installed on the wall)

1. Use the two screws supplied with control to attach the mounting bracket to the wall in a location selected by customer and within operating range.
2. Install batteries in the remote control.
3. Place the remote control into the remote control mounting bracket.
4. For remote control operation, refer to the unit owner's manual.

NOTE: If a wireless remote controller is used, relocate the IR receiver within line of sight of remote location using the 6 ft. cable included. The factory location of the IR receiver is inside the control box (see Fig. 48).

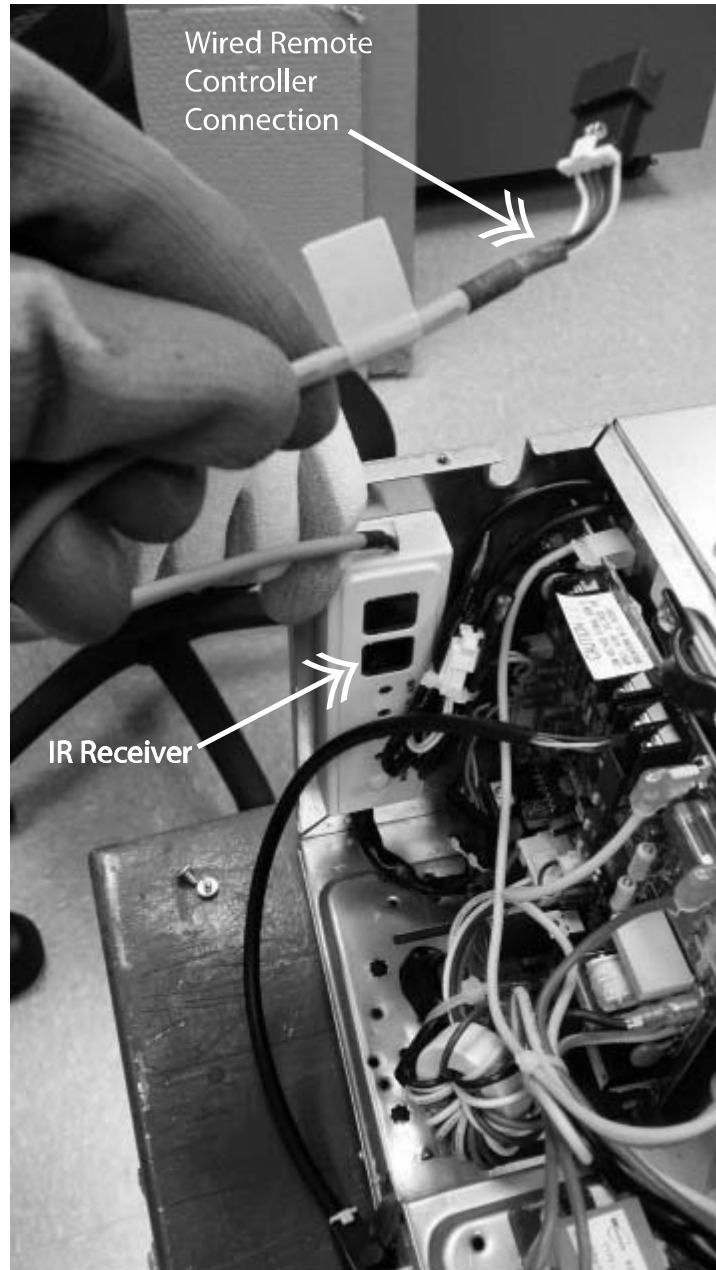

Fig. 48 – Control Box

A150642

WIRED REMOTE CONTROLLER INSTALLATION

To connect the wired remote controller (7 Day Programmable KSACN0501AAA) to the indoor unit, use 4-pin connector CN40 located on the control board.

To connect the wired remote controller (Timer Function KSACN0101AAA) to the indoor unit, use 5-core shielded cable and 5-pin connector from IR receiver located in the control box (see Fig 48).

For setup instructions, refer to the controller installation manual.

⚠ CAUTION

UNIT DAMAGE HAZARD

Failure to follow this caution may result in equipment damage or improper operation.

Never use the system compressor as a vacuum pump.

Refrigerant tubes and indoor coil should be evacuated using the recommended deep vacuum method of 500 microns. The alternate triple evacuation method may be used if the procedure outlined below is followed. Always break a vacuum with dry nitrogen.

Final Tubing Check

IMPORTANT: Check to be certain factory tubing on both indoor and outdoor unit has not shifted during shipment. Ensure tubes are not rubbing against each other or any sheet metal. Pay close attention to feeder tubes, making sure wire ties on feeder tubes are secure and tight.

START-UP

Test Operation

Perform test operation after completing gas leak and electrical safety check (see Fig. 49).

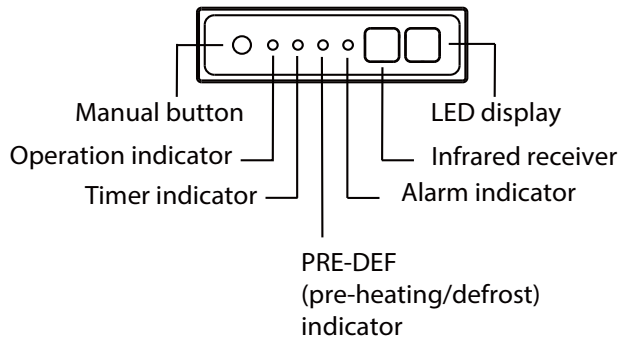

Fig. 49 – IR Receiver Display Panel

1. Press **MANUAL** on the IR receiver located in the control box to begin testing.

NOTE: A protection feature prevents air conditioner from being activated for approximately 3 to 4 minutes.

2. Push **MODE**, select **COOLING, HEATING, FAN** mode to check if all functions work correctly.
3. To run the test using the **MANUAL** button in the indoor unit:

- (3.) Open front panel of the indoor unit;
- (4.) Push the manual switch once to energize the unit.

The set conditions of manual operation are as follows:

- Preset set point: 76°F (24°C)
- Fan speed: **AUTO**
- Discharge air direction: Pre-set position based on operation in “Cool” or “Heat” mode.

4. Be sure to set the manual switch to **OFF** (by pushing it twice again) after finishing the test operation.

SYSTEM CHECKS

1. Conceal the tubing where possible.
2. Ensure the drain tube slopes downward along its entire length.
3. Ensure all tubing and connections are properly insulated.
4. Fasten tubes to the outside wall, when possible.
5. Seal the hole through which the cables and tubing pass.

INDOOR UNIT

1. Do all remote control buttons function properly?
2. Do the display panel lights work properly?
3. Does the air deflection louver function properly?
4. Does the drain work?

Explain Following Items To Customer (with the aid of the Owner’s Manual):

1. How to turn air conditioner on and off; selecting **COOLING, HEATING** and other operating modes; setting a desired temperature; setting the timer to automatically start and stop air conditioner operation; and all other features of the remote control and display panel.
2. How to remove and clean the air filter.
3. How to set air deflection louver.
4. Explain care and maintenance.
5. Present the owner’s manual and installation instructions to customer.

FAN MOTOR MAINTENANCE

The rear ventilated panel is used as an example.

Motor Maintain:

1. Take off the ventilated panel.
2. Take off the blower housing.
3. Take off the motor.

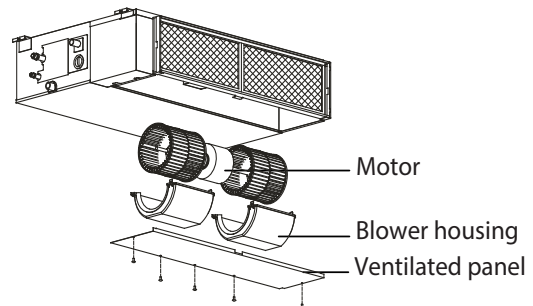

Fig. 50 – Maintain the Motor

TROUBLESHOOTING

For ease of service, the systems are equipped with diagnostic code display LEDs on both the indoor and outdoor units. The outdoor diagnostic display consists of two LEDs (Red and Green) on the outdoor unit board and is limited to a few errors.

The indoor diagnostic display is a combination of flashing LEDs on the display panel or the front of the unit. If possible, always check the diagnostic codes displayed on the indoor unit first.

The diagnostic codes displayed in the indoor and outdoor units are listed in Table 11.

INDOOR UNIT DIAGNOSTIC GUIDES

Table 11 – Indoor Unit Diagnostic Guides

OPERATION LAMP	TIMER LAMP	DISPLAY	LED STATUS
★ 1 time	X	E0	Indoor unit EEPROM parameter error
★ 2 times	X	E1	Indoor / outdoor units communication error
★ 8 times	X	EE	Water level alarm malfunction
★ 9 times	X	E8	Dual indoor unit (twin model only) communication malfunction
★ 10 times	X	E9	Other twin model malfunction
★ 1 time	O	F0	Overload Protection
★ 7 times	O	F6	Compressor low—pressure protection
★ 4 times	X	E3	Indoor fan speed has been out of control
★ 5 times	X	E4	Indoor room temperature sensor T1 open circuit or short circuit
★ 6 times	X	E5	Evaporator coil temperature sensor T2 open circuit or short circuit
★ 7 times	X	EC	Refrigerant leakage detection
★ 11 times	O	Fa	Indoor unit communication malfunction
★ 2 times	O	F1	Outdoor ambient temperature sensor T4 open circuit or short circuit
★ 3 times	O	F2	Condenser coil temperature sensor T3 open circuit or short circuit
★ 4 times	O	F3	Compressor discharge temperature sensor T5 open circuit or short circuit
★ 5 times	O	F4	Outdoor unit EEPROM parameter error
★ 6 times	O	F5	Outdoor fan speed has been out of control
★ 1 time	★	P0	IPM malfunction or IGBT over—strong current protection
★ 2 times	★	P1	Over voltage or over low voltage protection
★ 3 times	★	P2	High temperature protection of compressor top diagnosis and solution (9k,12k models only)
★ 4 times	★	P3	Outdoor low temperature protection
★ 5 times	★	P4	Inverter compressor drive error
★ 7 times	★	P6	Compressor low—pressure protection
★ 8 times	★	P7	Outdoor IGBT sensor error

O(light) X(off) ★(flash)

For additional diagnostic information, refer to the Service Manual.

