



Visit www.carrier.com

Installation and Start-Up Instructions

TABLE OF CONTENTS

	Page
SAFETY CONSIDERATIONS	1
INSTALLATION CONSIDERATIONS	1
INTRODUCTION	1
INSTALLATION	1-4
• Check Equipment And Job Site.....	1-2
• Component Location And Wiring Considerations.....	2
• Install Components.....	2
• Install Zone Dampers.....	2-4
• Install Barometric Bypass Damper.....	4
• Install Leaving Air Temperature (LAT) Sensor.....	4
• Install Heat Pump Temperature (HPT) Sensor.....	4
SYSTEM WIRING	4-5
• Wire Thermostats.....	4
• Wire Equipment.....	4
• Wire Dampers.....	5
• Wire Remainder.....	5
UNDERSTANDING SYSTEM OPERATION	6-7
SYSTEM SETUP	7-10

NOTE: Read the entire instruction manual before starting the installation.

SAFETY CONSIDERATIONS

Improper installation, adjustment, alteration, service, maintenance, or use can cause fire, electrical shock, or other conditions which may cause personal injury or property damage. Consult a qualified installer, service agency or your distributor or branch for information or assistance. The qualified installer or agency must use factory-authorized kits or accessories when modifying this product. Refer to the individual instructions packaged with the kits or accessories when installing.

Follow all safety codes and wear safety glasses. Have fire extinguisher available. Read these instructions thoroughly and follow all warnings or cautions attached to the unit. Consult local and state building codes and Sheet Metal and Air Conditioning National Association (SMACNA) for special installation requirements.

Recognize safety information. This is the safety-alert symbol . When you see this symbol on the unit or in instructions and manuals, be alert to the potential for personal injury.

Understand the signal words DANGER, WARNING, and CAUTION. These words are used with the safety-alert symbol. DANGER identifies the most serious hazards which **will** result in severe personal injury or death. WARNING signifies hazards which **could** result in personal injury or death. CAUTION is used to identify unsafe practices which **would** result in minor personal injury or product and property damage. NOTE is used to highlight suggestions which will result in enhanced installation, reliability, or operation.

INSTALLATION CONSIDERATIONS

Before the actual installation of a zoning system can begin, decisions need to be made to determine the number and location of zones. This affects duct and damper selections.

This instruction covers the physical installation and start up of the Carrier 3-Zone system. Use this instruction to guide the actual installation process after all the air side decisions have been made.

1. Install in non-condensing areas with ambients between 32°F and 158°F.
2. A TXV is required on the indoor coil when used with all residential split system equipment.
3. A separate transformer is not needed to power the 3-Zone system. Up to five dampers may be used in each zone by electrically connecting them in parallel.
4. Load calculations must be performed for each zone's peak demand. Size each zone duct for at least its peak demand plus 25%. Size equipment for the building block load, not the sum of zone peak demands. It is important that the equipment not be oversized.
5. When only two zone operation is needed, any two of the three zone connections may be used. There is no inherent priority dependent on zone number.

CAUTION

UNIT DAMAGE HAZARD

Failure to follow this caution may result in unit damage. TXV on indoor coil is required with all residential split system equipment.

INTRODUCTION

The Carrier 3-Zone system allows the air conditioning and heating equipment to control temperatures in 3 distinct spaces or zones within a building. Each zone has independent temperature settings controlled by a conventional thermostat.

There are two distinct controllers:

- ZONECC3ZAC01 - Single Stage Heat / Single Stage Cool using conventional single stage thermostats.
- ZONECC3ZHP01 - Three Stage Heat / Two Stage Cool compatible for HP and multi-stage application thermostats and equipment.

Each system controller is comprised of a three-zone controller and a duct temperature sensor.

NOTE: Thermostats are purchased separately.

The comfort temperature settings can change automatically through the use of schedules if programmable thermostats are selected. This allows the Carrier 3-Zone to change the temperature settings in zones to reflect occupancy or usage. The Carrier 3-Zone system uses motorized air volume control dampers (also called zone dampers) to regulate the flow of conditioned air into the zones.

INSTALLATION

Step 1—Check Equipment and Job Site

INSPECT EQUIPMENT — File claim with shipping company, prior to installation, if shipment is damaged or incomplete.

Manufacturer reserves the right to discontinue, or change at any time, specifications or designs without notice and without incurring obligations.

Step 2—Component Location and Wiring Considerations

⚠ WARNING

ELECTRICAL SHOCK HAZARD

Failure to follow this warning could result in personal injury or death.

Turn off unit before routing control wiring or any service operation. Remember, there may be more than one power supply to unit.

All wiring must comply with national, local, and state codes.

LOCATING CARRIER 3-ZONE SYSTEM — All wiring is run back to the Carrier 3-Zone System. Select a location near the furnace or fan coil where wiring from each thermostat, each damper actuator, and the equipment itself can come together easily.

The Carrier 3-Zone System is approved for indoor use only and should never be installed with any of its components exposed to the elements. It may be installed in any area where the temperature remains between 32° and 158°F, and there is no condensation. The cover must be installed to prevent damage from other sources. Do not locate where it will be accessible to children. It may be mounted in either vertical or horizontal position. Remember that wiring access is likely the most important consideration.

⚠ CAUTION

EQUIPMENT DAMAGE HAZARD

Failure to follow this caution may result in equipment damage.

To prevent possible damage to Carrier 3-Zone System, do not mount control on plenum, duct work, or flush against furnace.

LOCATING THERMOSTATS — For proper operation, each thermostat must accurately measure the temperature within its zone.

For accurate temperature measurement, the following guidelines should be followed:

Thermostat should be mounted:

- Approximately 5 ft. (1.5m) from floor.
- Close to the center of its zone, preferably on an inside wall.
- On a section of wall without pipes or duct work.

Thermostat should NOT be mounted:

- Close to a window, on an outside wall, or next to a door leading to the outside.
- Where it will be exposed to direct light and heat from a lamp, sun, fireplace, or other temperature radiating object which may cause a false reading.
- Close to or in direct airflow from supply registers and return-air grilles.
- In areas with poor air circulation, such as behind a door or in an alcove.

WIRING CONSIDERATIONS — All wiring in the Carrier Three-Zone system may be unshielded. Ordinary thermostat wire is ideal. Use 22 gage or larger for normal wiring. Lengths over 100 ft. should use 20 gage or larger wire.

Each damper actuator requires 3 conductors. The connection to thermostats and equipment (furnace or fan coil) could require as many as 8 conductors for a multi-stage installation. The leaving air temperature (LAT) and heat pump temperature (HPT)—(used with *heat pumps only*) sensors require 2 conductors each.

Cables with excess conductors are acceptable. Cut off or fold back and tape any unneeded conductors.

Plan the routing of wiring early to avoid possible problems later on.

Remember all wires converge at the Carrier 3-Zone system, so its location is important.

Step 3—Install Components

INSTALL CARRIER 3-ZONE SYSTEM

The Carrier 3-Zone System is designed so that wires can enter it from behind, above, or below. Plan wire routing before mounting.

1. Open door to access eight mounting screw slots
2. Mount to wall using four screws and wall anchors provided.
3. Level and tighten screws.

INSTALL THERMOSTATS

1. Follow manufacturer's supplied instructions for installing thermostats.

⚠ CAUTION

EQUIPMENT DAMAGE HAZARD

Failure to follow this caution may result in equipment damage.

Improper wiring or installation may damage the thermostats. Check to make sure wiring is correct before proceeding with installation or turning on unit.

Step 4—Install Zone Dampers

Proper selection and sizing of dampers is important for proper system operation. Selection and sizing information is not provided in this installation instruction.

If duct work requires multiple dampers for a single zone, up to 5 dampers may be wired in parallel.

Zone dampers may be installed in any position.

Install dampers so that actuator is visible for inspection and accessible in the event it would ever need to be serviced. The black mark on the end of damper shaft represents position of damper blade.

The 45 degree actuators on round ducts have their mechanical stops set at 45 degrees. **DO NOT CHANGE THIS SETTING.** Doing so will allow the actuator to close when it is trying to open. If an actuator is removed, it must be properly aligned when it is reinstalled. Do this by rotating the actuator and the blade to their closed positions and then tightening the actuator to the shaft. This assures alignment at the closed position. (Pressing the blade release button releases the motor and allows the actuator to be manually turned.)

⚠ CAUTION

EQUIPMENT DAMAGE HAZARD

Failure to follow this caution may result in equipment damage.

When dampers are located in an unconditioned space, condensation is likely to occur in cooling. Regular and severe condensation will damage the actuator. To prevent condensation and losses, all dampers and ductwork in unconditioned space must be insulated or otherwise protected.

Whenever condensation might occur, it is recommended that plastic actuator covers (Part# DAMPACTXXCOV) be used over the actuator. These covers can help prevent condensation on actuators by locking out ambient humidity. Insulation may be applied over the cover to minimize heat transfer.

To install, place the cover over actuator and seal in place over the surrounding insulation with duct tape on all four sides. Sealing

need not be perfect because there will be positive pressure inside the cover. Do not mount the dampers with their actuators hanging directly beneath the ductwork. It is best to mount the actuator facing in either the three or nine o'clock position.

For specific duct types, follow instructions below:

ROUND METAL DUCT WORK

1. Crimp end of branch duct.
2. Slip end of zone damper over end of duct work. Use self-tapping sheet metal screw to secure. (See Fig. 2.)
3. Properly seal joint using duct tape, mastic, or other approved method. Do not allow mastic to come in contact with actuator.
4. Insulate damper using 1-1/2 in. to 2-in. insulation. (Check your local codes.)

NOTE: All zone dampers and duct work must be properly supported according to local codes or SMACNA standards.

RECTANGULAR METAL DUCT WORK

1. Make connections using S-lock and drives. (See Fig. 2.)
2. Properly seal joint using duct tape, mastic, or other approved method. Do not allow mastic to come in contact with actuator.

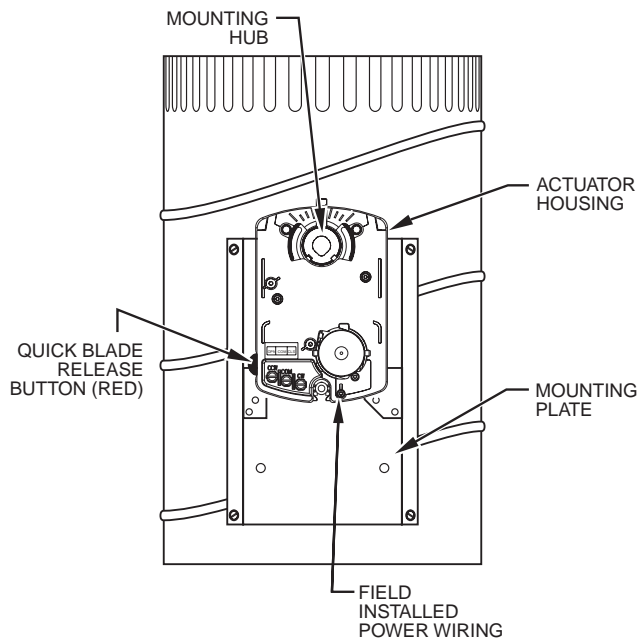

Fig. 1—Damper 24-vac Connections

C02083

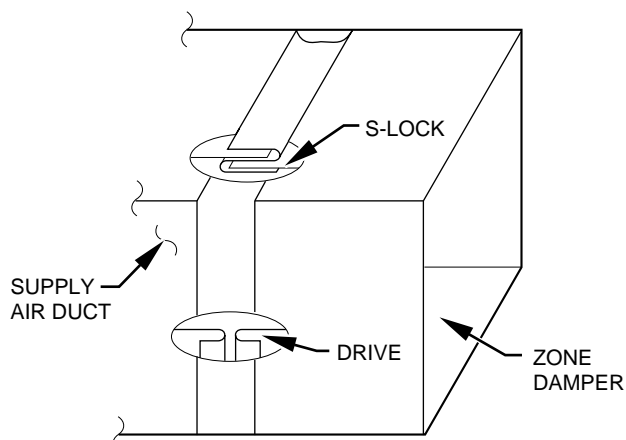
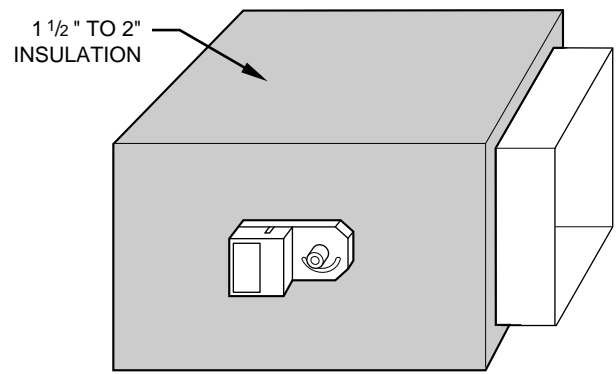

Fig. 2—Rectangular Metal Duct Work

A92478

3. Insulate damper using 1-1/2 in. to 2-in. insulation. (Check your local codes.) (See Fig. 3.)



A95131

Fig. 3—Insulated Rectangular Metal Duct Work

ROUND FLEXIBLE DUCT WORK

1. Slip 1 end of flexible duct work over 1 end of zone damper. (See Fig. 4.)

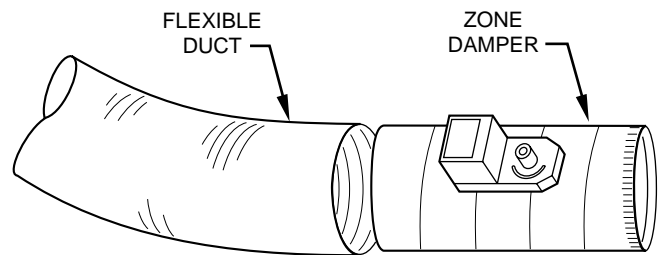

A95132

Fig 4—Round Flexible Duct Work

2. Secure flexible duct to zone damper using SMACNA or other approved method.
3. Properly seal joint using duct tape, mastic, or other approved method. Do not allow mastic to come in contact with actuator.
4. Insulate damper using 1-1/2 in. to 2-in. insulation. (Check your local codes.) (See Fig. 5.)

NOTE: All zone dampers and duct work must be properly supported according to local codes or SMACNA standards.

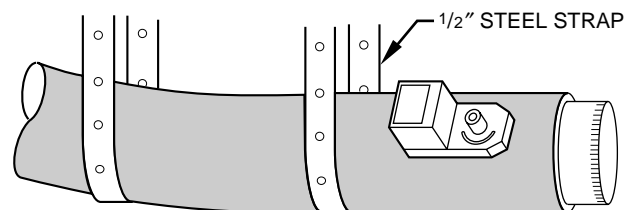

A95133

Fig. 5—Insulated Round Duct Work

RECTANGULAR FIBROUS GLASS DUCT WORK

1. Insert 1 end of zone damper into 1 end of fibrous glass duct work approximately 2 to 3 in. (See Fig. 6.)
2. Screw field-supplied screws and tabs into zone damper.
3. Properly seal joint using duct tape, mastic, or other approved method. Do not allow mastic to come in contact with actuator.
4. Insulate damper using 1-1/2 in. to 2-in. insulation. (Check your local codes.) (See Fig. 7.)

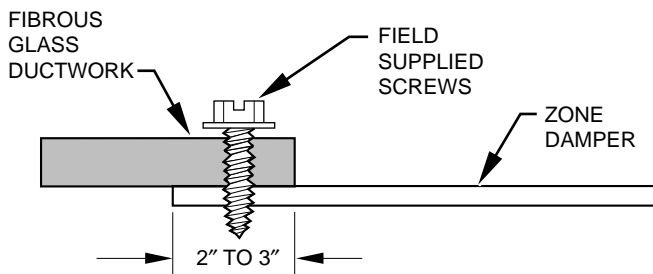

A92480

Fig. 6—Rectangular Fibrous Glass Duct Work

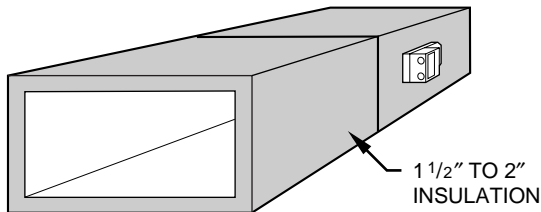

A95134

Fig. 7—Insulated Rectangular Fibrous Glass Duct Work

Step 5—Install Barometric Bypass Damper

NOTE: The barometric bypass damper is a critical part of Carrier 3-Zone System for controlling noise at minimum airflow. A barometric bypass should be installed unless the duct work and indoor unit have been sized for use without a bypass.

The bypass should be installed according to local codes and SMACNA standards. Be sure bypass is properly supported.

For proper installation, refer to Installation Instructions packaged with barometric bypass.

Step 6—Install Leaving Air Temperature (LAT) Sensor

NOTE: The supplied LAT sensor must be installed for normal operation. Heat pump systems may use an optional HPT (heat pump temperature) sensor for added protection. These sensors protect the equipment when leaving air temperatures approach excessive levels.

Locate LAT sensor in main supply trunk after heating and cooling coil and before bypass damper and first branch. The LAT sensor is radiant shielded to prevent heat from affecting correct air temperature.

1. Drill a 1/4-in. hole at location in supply trunk where sensor will be installed.
2. Insert sensor in hole and use as a template to mark the 2 mounting holes.
3. Drill two 1/16-in. holes to accept No. 6 screws through pre-drilled holes in duct temperature sensor back plate.
4. Use 2 No. 6 sheet metal screws to mount duct temperature sensor to unit.
5. Connect sensor to 2-conductor wire using provided wire nuts. (See Fig. 9, 10, or 11 for connection to Carrier 3-Zone System.)

Step 7—Install Heat Pump Temperature (HPT) Sensor

The optional HPT sensor is recommended in all heat pump/fan coil installations. If an optional HPT sensor is not used, the 10K ohm resistor attached to the two HPT terminals on the board must be left in place. The HPT sensor measures the temperature of the air leaving the indoor coil. The sensor is to be installed downstream of the indoor coil but before the electric heaters. It can be installed

through the wall of the fan coil or may be located entirely inside the fan coil near the blower inlet. Anchor firmly in place with cable ties so that it cannot interfere with the blower wheel.

SYSTEM WIRING

Wiring the system is best done in four steps. Thermostats, Equipment, Dampers, and Remainder. The descriptions below and Table 1 will help you choose the correct wiring diagram for your system. Table 1 also shows the proper setting of dipswitches 9 and 10 for each diagram. Based on the equipment, 3-zone control, and thermostat type, select the appropriate wiring diagram. Terminal designations on all the thermostats are those of Carrier thermostats. Other brands may vary somewhat. Wiring diagrams and 3-Zone Control board layouts are located at the end of this Installation Instruction.

Table 1—Wiring Diagram Selection Chart

WIRING DIAGRAM	EQUIPMENT	3-ZONE TYPE	STAT TYPE	SWITCH 9	SWITCH 10
Fig. 10	1-spd. AC, 1-Stg. heat	AC	AC	not present	not present
Fig. 11	1-spd. AC, 1 or 2-stg. heat	HP/2S	AC	ON	ON
Fig. 12	1-spd. HP, 1-stg. aux heat	HP/2S	HP	OFF	OFF
Fig. 13	1-spd. HP, 1-stg. aux heat	HP/2S	AC (2 ht)	OFF	ON
Fig. 14	2-spd. AC, 1 or 2-stg. heat	HP/2S	2S (AC)	ON	ON
Fig. 15	2-spd. HP, 1-stg. aux heat	HP/2S	2S (HP)	OFF	OFF

Fig. 8 - Shows the board layout for the AC Control.

Fig. 9 - Shows the board layout for the HP/2S Control.

Fig. 10 - Shows the 3-Zone AC Control wiring. It supports only 1 stage cooling and 1 stage heating.

Fig. 11 - Shows that the 3-Zone HP/2S Control may be used in 1 stage cooling and 1 or 2 stage heating applications. For 2 stage heating, the stat may be a 2 stage heat AC stat or a HP stat converted to AC. (Carrier HP stats can be field converted to 2 stage heat AC stats.)

Fig. 12 - Shows the conventional HP system, using a HP stat. Only single stage auxiliary heat is supported for heat pump systems. Using the HP stat allows control of emergency heat directly from the stat.

Fig. 13 - Is also a HP system, but uses an AC stat with 2 stage heating instead of a HP stat. (Carrier HP stats can be field converted to 2 stage heat AC stats.) Here, emergency heat can only be selected by a switch on the 3-Zone Control.

Fig. 14 - Is a 2 speed AC system and may have 1 or 2 stages of heat. An HP/2S Control and a 2S stat set for AC operation must be used.

Fig. 15 - Is for a 2 speed HP. It requires an HP/2S Control and a 2S stat set for HP operation. Only single stage auxiliary heat is supported for heat pump systems.

Step 1—Wire Thermostats

All zone thermostats are wired identically, so only the Zone 1 thermostat is shown on the wiring diagrams. For physical location of connections on 3-Zone Control refer to Fig. 8 (AC Control) or 9 (HP Control).

Battery or power stealing thermostats may not require the C connection. Refer to thermostat Installation Instructions. Be careful not to cross zone numbers.

Step 2—Wire Equipment

Again, from the selected Fig. 10 through 13, make each connection as shown at the indoor and outdoor units and the 3-zone Control.

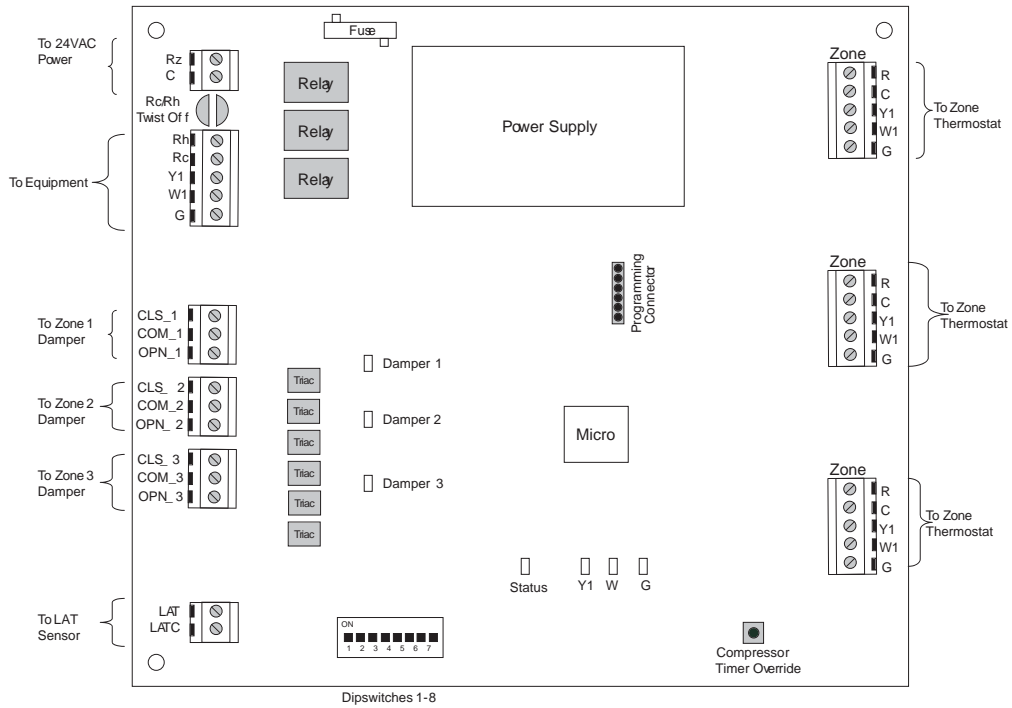

Fig. 8—AC or 1-Stage System Wiring Diagram

A04192

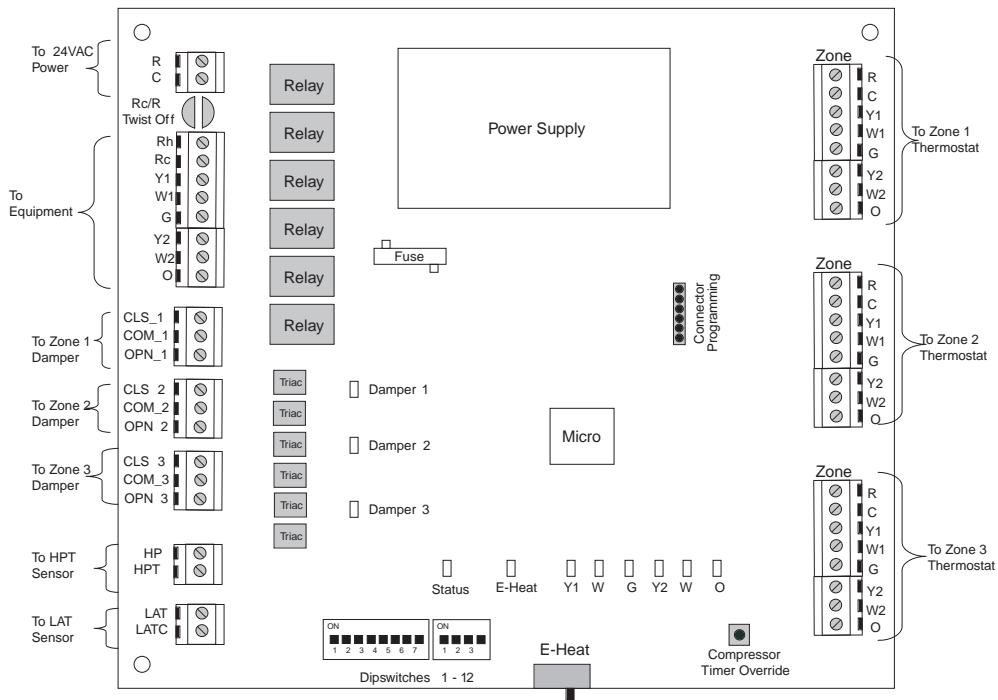

Fig. 9—HP or 2-Stage System Wiring Diagram

A04191

Connect the equipment R to both Rz and either Rh or Rc. A jumper will be needed. Rc and Rh are internally connected but may be separated by breaking a twist-off (see step 4 below).

Step 3—Wire Dampers

Each damper has three connections: Close, Open, and Common. Find the connection points along the lower left side of the 3-Zone Control. Suggested colors are Close = red; Open = green; Common = white. Field label and make the connections at the dampers and at the 3-Zone Control. Be careful not to cross zone numbers.

Step 4—Wire Remainder

Connect the LAT sensor to the LAT and LATC terminals. Polarity does not matter. If used, connect the HPT sensor to the HPT and HPTC terminals. If the HPT sensor is not used, you **must** leave the 10K ohm resistor connected in its place.

If the cooling and heating systems have separate transformers, twist off the Rc/Rh jumper using a pair of long nosed pliers. Then connect the R of the cooling transformer to Rc, the R of the heating transformer to Rh and the common of both transformers to C. Connect a jumper wire between Rz and Rc. Rc powers G, Y, and O outputs. Rh powers W outputs.

UNDERSTANDING SYSTEM OPERATION (READ BEFORE STARTING SYSTEM)

Mode and Damper Positions

The thermostats determine the system heating or cooling mode. The first call in any zone sets the mode to satisfy that call. It will remain in that mode until all calls in that mode are satisfied and the equipment has been off for the time set by the auto changeover time dipperswitches. (See Timers section.)

In normal heating or cooling, the damper of any zone with a call in the current mode will be open and all other zones will be closed. When there is no call, any zone with its fan set to ON will be open, and any zone with its fan set to AUTO will be closed. If any zone fan is set to ON, the blower will be energized.

If all fan settings are AUTO, the dampers will remain in their last position before the equipment turned off and the blower will be off. (This normally means one damper open and all others closed.)

When dampers are to move, all opening is done first, followed by all closing.

Stages

In multi-stage systems, the equipment stage is set by the greatest thermostat call, but may be delayed by the control's cycle and staging timers. (See timers explanation below.) The AC Control supports only single stage heat and cool. The HP control supports two stage cooling, two stage furnace heating, and three stage HP heating (lo HP, hi HP, hi HP + aux heat.)

Emergency Heat

Emergency heat (aux heat without compressor heat) can be selected for a HP system by either of two ways: First, by selecting Eheat using the Eheat override switch on the HP Control, or second, selection of Eheat on each of the thermostats, provided they have the Eheat function. When either of these Eheat selections is made, a heating demand provides a W signal without a Y signal to the equipment.

NOTE: The second Eheat method requires HP thermostats and that they all must be set to Eheat.

Indicator LEDs

There are 7 indicator LEDs on the AC Control and an additional 3 on the HP/2S Control. Their locations are shown on Fig. 8 and 9. Each damper has its own green LED which is ON when the damper opens due to a calling condition or partially open due to an LAT or HPT limit condition.

Each equipment output has its own LED which is on when that output is energized. Y and O outputs are yellow, W outputs are red and the G output is green.

In addition, there is a status LED whose operation is described under the section **Error Codes**.

Timers

To control excessive equipment cycling or rapid staging up, the control has two timers. The cycle timer prevents the same stage from turning on within 10 minutes of the last time it turned on. This allows a stage to turn on for as short or as long as the thermostats request, but will not allow more than six cycles per hour.

The staging timer prevents a higher stage from turning on until the next stage below it has been on for 15 minutes. This minimizes use of electric heat with heat HP systems.

There is also a timeguard timer which will not allow the compressor to be turned on until it has been off for five minutes.

A changeover timer, which can be set from 0 to 30 minutes, limits the control's ability to switch between heating and cooling. The opposite mode is prevented from coming on until the first mode has been satisfied for the selected time.

Timer Override

A momentary switch is located near the bottom of the control circuit board. Pressing it momentarily overrides all of the system timers, allowing the control to immediately jump to the highest calling stage.

Temperature Limits and Sensors

Both the AC and HP controls have a LAT (leaving air temperature) sensor which is to be placed in the downstream air path of the heating /cooling equipment. It is used in both heating and cooling to limit LAT to a safe value. It must be connected. The system will not operate without it. Its setting is fixed for cooling and is adjustable in four settings for heating. Selection of best setting is discussed under **LAT Limit Selection**.

The HP control also has an optional HPT Sensor (heat pump temperature) which is to be placed downstream of the coil but ahead of the electric heater. This sensor measures the temperature of the air leaving the coil during HP heating. It is not included with the control, but may be ordered separately as part number TSATXXSEN01-B. A 10K ohm resistor is factory installed in its place when the actual sensor is not used. In the HP control only, dipswitch 11 allows the installer to temporarily disable both the LAT and the HPT sensors. Disabling of these sensors is only to be done on a temporary basis.

⚠ CAUTION

UNIT DAMAGE HAZARD

Failure to follow this caution may result in unit damage.

Operating equipment with sensors disabled can cause permanent damage to HVAC equipment.

Bypass

The purpose of a bypass is to limit noise in the duct system when the dampers are excessively restricting it. When a direct bypass (outlet air fed back directly into the return) is used, bypassing decreases entering air temperature in cooling and increases it in heating. Excessive bypassing will lead to limit trips, either through the LAT /HPT sensors or the equipment internal limits.

Setting the Bypass

Setting the bypass is a balance between too much noise (bypass trip pressure set too high) and excessive bypassing which will cause limit trips, diminishing performance. As a general rule, the bypass should remain closed as much as possible. It should never open when all the dampers are open and only open as much as needed to bring noise to an acceptable level when only one damper is open. (See **System Setup** for details.)

LAT Limit Selection

Cycling on internal equipment limits is to be avoided because it overstresses and can shorten the life of the equipment. Therefore, the LAT limit setting should be selected to trip below the equipment limit. See **System Setup** for details on how to choose one of four available LAT limits.

Limit Levels and Actions

The response of the system to the LAT/HPT sensors are shown in Table 2. Cooling and HP limits are not adjustable. Looking at Table 2, there are eight limit level index numbers, 0 through 7. These represent the closeness of the actual LAT/HPT temperatures to the final shutdown limit. 0 represents no limit challenge while 7 indicates a final shutdown of the equipment. Note that progressive actions are taken by the control as the LAT/HPT limit is approached. Each action progressively reduces the limit challenge by increasing airflow. Normally, the system will stabilize at limit level 1 or 2 because opening all closed dampers 2 or 4 positions (out of 15) will reduce LAT to a level below its limit.

Table 2—Limit Temperature Levels and Actions

LIMIT LEVEL	0	1	2	3	4	5	6	7
Cooling Limit (40 deg) above	47	46	45	44	43	42	41	40
HP limit (115 deg) below	107	108	109	110	111	112	113	115
Heat Limit (130 deg) below	119	121	122	124	125	127	128	130
Heat Limit (145 deg) below	131	133	135	137	139	141	143	145
Heat Limit (160 deg) below	143	145	148	150	153	155	158	160
Heat Limit (175 deg) below	155	158	161	164	166	169	172	175
LIMIT ACTIONS								
"Closed" Damper Positions	0	2	4	6	8	10	12	14
Allowed stages (1 stg)	1	1	1	1	1	1	1	0
Allowed Stages (2 stg)	2	2	2	1	1	1	1	0
Allowed stages (3 stg)	3	3	3	2	2	1	1	0

Using Limit Level Indicator

The final setting of the bypass for best performance has always been something of a black art. The 3-Zone System has a new feature to simplify this adjustment. While the system is operating, these limit level numbers, if greater than zero, are flashed on the status LED.

Once the proper LAT limit choice is made based on equipment maximum rise, the limit level indicator assists in setting the bypass pressure adjustment. See **System Setup** for details.

Installer Test Mode

Dipswitch 4 selects a special Installer Test Mode, designed to assist the installer (or service person) to commission the system. It verifies damper movement in proper zone and that the heating and cooling equipment operates properly at each stage. When this mode is selected, by moving dipswitch 4 to ON, the following sequence will be executed once:

Step 1 — Two minutes, one flash of status LED. The blower is energized with G, damper 1 opens, and other dampers are closed.

Step 2 — Two minutes, two flashes of LED: With the blower on, damper 1 closes and damper 2 opens.

Step 3 — Two minutes, three flashes of LED: With the blower ON, damper 3 opens and damper 2 closes.

Step 4 — Two minutes, four flashes of LED: All dampers open, first stage of heat turns on. For HP control only, this is followed by the second stage of heat (HP plus aux heat, hi HP, or hi furnace) for two more minutes. For HP control with two stage compressor, the third stage of heat (hi HP plus aux heat) comes on for a third 2 minute period.

Step 5 — Two minutes, five flashes of LED: All dampers are open and first stage of cooling turns on for 2 minutes. For HP board only, second stage of cooling comes on for an additional 2 minutes.

At the end of Step 5, the control returns to normal operation. To restart the test sequence, the switch must be moved to OFF and then back to ON.

If zoning is disabled (Switch 5 = ON), the procedure above will be followed, except all the dampers will remain open throughout the sequence.

SYSTEM SETUP

Thermostats

Read the thermostat Installation Instructions and be sure to complete the required setup of these devices before using them to bring on the equipment. If the thermostats have a "zoning" selection, be sure to turn it on. This will eliminate the timers within the thermostat and allow the 3-Zone control's timers to do their job.

There are 8 dipswitch settings on the AC zone control and an additional 4 on the HP board. Below is a table summarizing their function. Below the table is a more detailed description of what each does and how to set it properly for your application.

Table 3—Dipswitch Settings

DIPSWITCH 1 POSITION	ACTION (OFF)	ACTION (ON)
1	Auto changeover Timer Active	Defeat Auto Changeover Timer
2	Auto Changeover 20 Minutes	Auto Changeover 30 Minutes
3	Auto Changeover Timer X 1	Auto Changeover Timer X .5
4	Normal Operation	Installer Test
5	Zoning Enabled	Zoning Disabled
6	Fan With W Disabled	Fan With W Enabled
7	LAT Setting	LAT Setting
8	LAT Setting	LAT Setting

Table 4—Dipswitch Settings for HP Control Only

DIPSWITCH 2 POSITION	ACTION (OFF)	ACTION (ON)
9	HP Operation	AC Operation
10	HP Thermostat	AC Thermostat
11	LAT and HPT Safeties Enabled	LAT and HPT Safeties Disabled
12	Reversing Valve Energized in Cooling (O)	Reversing Valve Energized in Heating (B)

Dipswitches

Dipswitch 1 - This determines whether or not a minimum time must pass before the control is allowed to transition between heating and cooling or vice versa. If it is set to ON, there is no time requirement. Default is OFF.

Dipswitch 2 - This switch, together with dipswitch 3, determines the changeover time, effective if switch 1 is OFF. ON sets 30 minutes. OFF sets 20 minutes. Default is OFF.

Dipswitch 3 - This is a multiplier, modifying the time set on switch 2. ON multiplies the set time by 0.5. OFF multiplies the set time by 1.0. Default is OFF.

Dipswitch 4 - This selects the Installer Test Mode, used to check system operation. Details are provided in section **Installer Test**. ON selects Installer Test. OFF selects normal operation. Default is OFF.

Dipswitch 5 - Enables and disables zoning. ON disables zoning, with all dampers open and zone 1 thermostat controlling. OFF selects normal zoning operation. Default is OFF.

Dipswitch 6 - Selects G ON or OFF with W. Selecting ON causes G to be energized whenever W is energized. Selecting OFF does

not bring on G with W. Default is OFF.

Dipswitch 7 and 8 - Sets LAT limit temperature. See **LAT Limit Selection** for proper setting. Default is OFF = 145° limit.

The following dipswitches are on the HP/2S control only:

Dipswitch 9 - Informs the control whether it is connected to a heat pump or an air conditioner. OFF selects HP. ON selects AC. Default is OFF (HP).

Dipswitch 10 - Informs the control of the type of thermostat being used. OFF selects HP thermostat. ON selects AC thermostat. A HP thermostat may **not** be selected if the system selection is AC. A 2-stage heat AC thermostat or a HP thermostat may be used with a single stage HP. Default is OFF.

Dipswitch 11 - Disables LAT and HPT safeties when ON. ON is intended only for emergencies. When ON is selected, there is no over/under temperature protection for the equipment. Default is OFF.

Dipswitch 12 - Informs the control whether the reversing valve is energized in cooling (O function) or heating (B function). ON selects B function. OFF selects O function. Default is OFF.

LAT Limit Selection

To accommodate varying heat rises in furnaces and fan coils, the LAT limit adjustment has four selections: 130, 145, 160 and 175 degrees. In addition to these, the HPT limit is fixed at 115 degrees and the cooling limit (also sensed by LAT sensor) is 40 degrees. To select the proper limit, check or calculate the rated maximum rise of the equipment. Add 75 degrees to this value. Pick the closest LAT limit choice below this value and use dipswitches 7 and 8 to enter this value using:

Table 5—LAT Limit

TEMPERATURE	SWITCH 7	SWITCH 8
130	OFF	ON
145 (default)	OFF	OFF
160	ON	OFF
175	ON	ON

Take a minute to study the LAT Limit table. Note that the limits are the final shutdown temperatures, but actions begin earlier. First, at levels 1 and 2, closed dampers begin to open gradually, followed at level 3 by staging down of multi stage equipment, if it exists. Under most limit challenges, the system will stabilize between 1 and 3 due to opening of closed dampers.

⚠ CAUTION
UNIT DAMAGE HAZARD
Failure to follow this caution may result in unit damage. Setting LAT limit too high can shorten the life of the HVAC equipment.

Automatic Checkout

An automatic checkout procedure is provided which will exercise dampers, heating, and cooling in that order. It is described under the **Understanding System Operation** section in **Installer Test Mode**. This may be used or the system may be checked out manually by creating thermostat calls. When using thermostats, remember that only the calling zoning dampers will be open. This provides the means to select which dampers are open for any heating or cooling call. It is advisable that the initial checkout be made with all dampers open before the bypass is set. This can be done by temporarily setting Switch 5 to ON (disable zoning) and controlling the equipment from the Zone 1 thermostat. When the equipment is operating satisfactorily, return Switch 5 to OFF and proceed to the next section.

Bypass Adjustment

The bypass should be set to the highest possible pressure setting consistent with an acceptable air noise level. To set, operate the system with a call from the smallest zone at its highest airflow (highest may be either heating or cooling). This condition forces the largest amount of air through the smallest duct, creating the highest static pressure at the bypass. Adjust the bypass pressure setting so that the bypass stays closed. Then check to determine if the level of noise and "blow" in that zone is acceptable. If it is unacceptable, reduce the bypass pressure setting (see bypass instructions for how to adjust) until it just begins to crack open. Check again, continuing the process until an acceptable noise and "blow" level is reached.

If, under this condition, the LAT approaches its limit, the system will open the other closed dampers until the LAT reaches an acceptable level. This operation is acceptable. The system will automatically open dampers enough to keep the LAT at a safe value, and will do it only when the zone demands require it. You may observe the limit level on the status LED (if it is above zero). If it stabilizes at a value of higher than 2, an overly small duct system is indicated and it would be desirable to raise the bypass pressure setting, if possible.

Error Codes

The status LED indicates normal operation, problems, and LAT/HPT limit status according to a two digit code. The first digit flashes its number, followed by a 2 second pause, followed by the second digit, followed by a 4 second pause. The cycle repeats. The codes are:

Table 6—Error Codes

ON CONTINUOUSLY	NO PROBLEMS
11 - 17	LAT limit level 1 - 7
21 - 27	HPT limit level 1 - 7
31	LAT shorted
32	LAT open
33	HPT open
34	HPT shorted
41	Invalid: Sw 9=ON; Sw 10=OFF

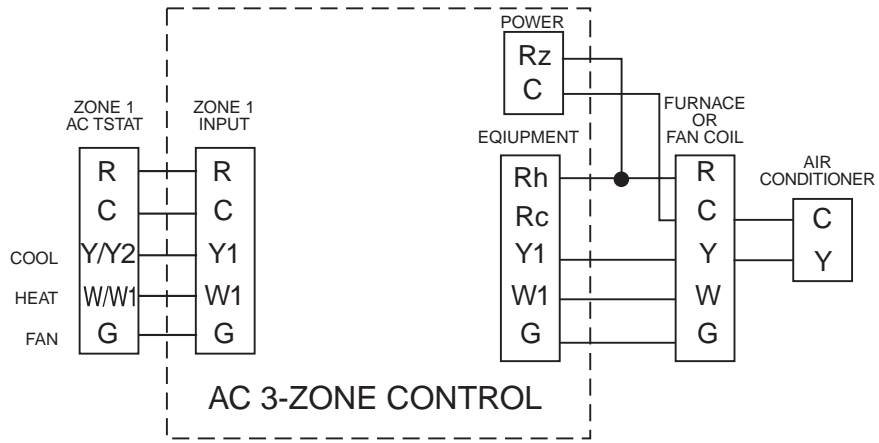

Fig. 10 — AC 3-Zone Control, AC STAT, 1-Stg. AC with 1-Stg. Heat

A04196

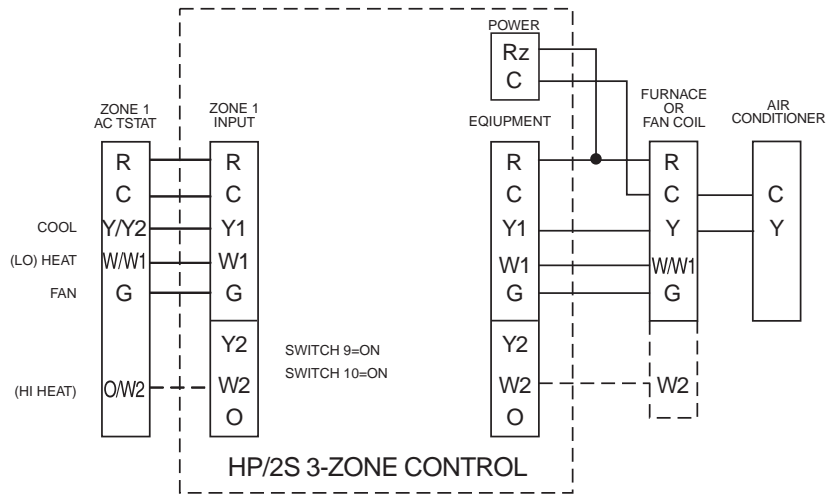

Fig. 11 — HP/2S 3-Zone Control, AC Stat, 1-Stg. AC with 1 or 2-Stg. Heat

A04197

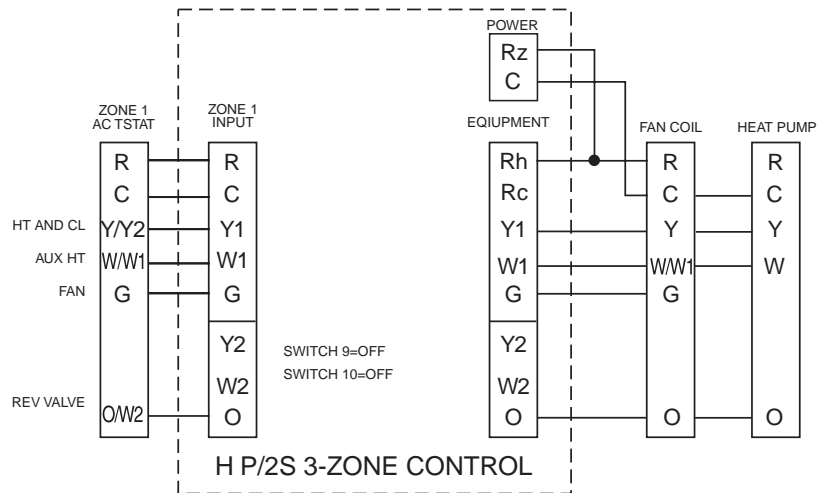

Fig. 12 — HP/2S 3-Zone Control, HP Stat, 1-Stg. HP with 1-Stg. Aux. Heat

A04198

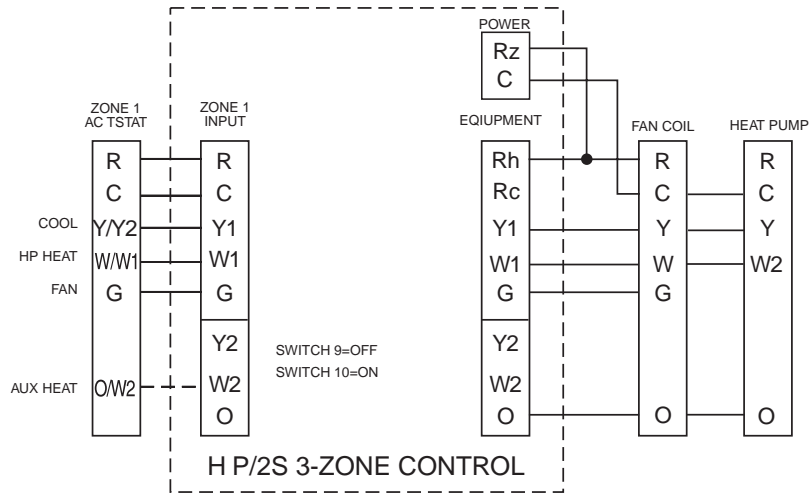

Fig. 13 — HP/2S 3-Zone Control, AC Stat, 1-Stg. HP with 1-Stg. Aux. Heat

A04199

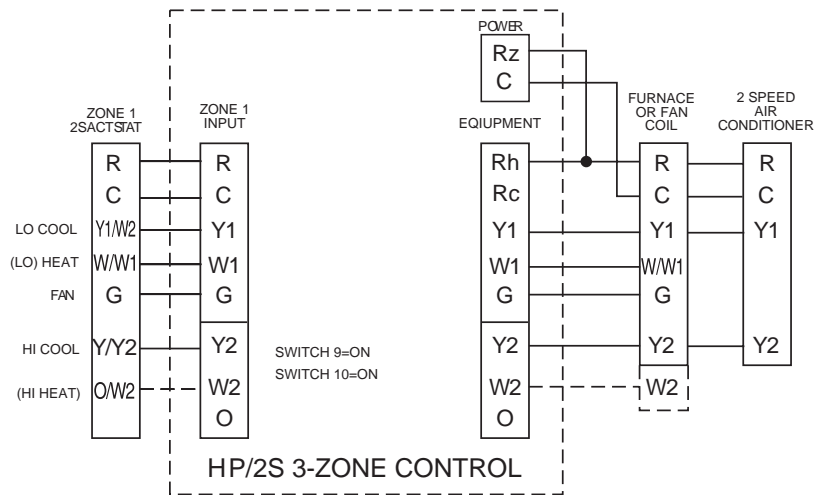

Fig. 14 — HP/2S 3-Zone Control, AC Stat, 2-Spd AC with 1 or 2-Stg. Heat

A04200

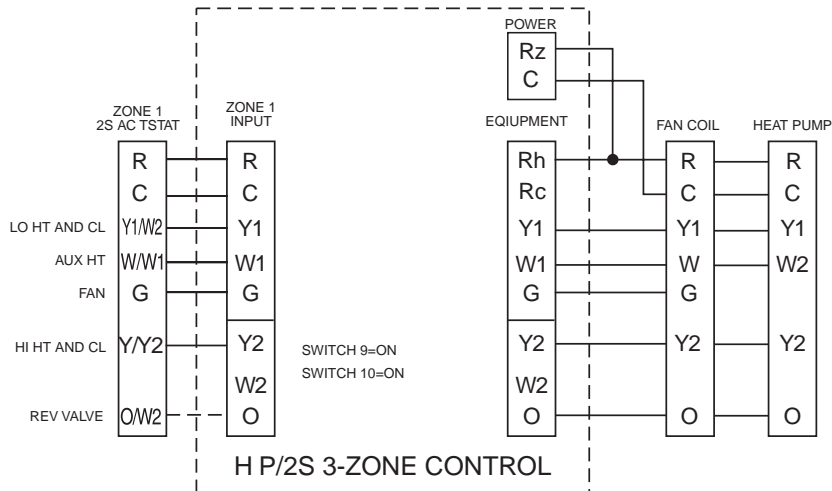

Fig. 15 — HP/2S 3-Zone Control, HP Stat, 2-Spd HP with 1-Stg. Aux. Heat

A04201

SERVICE TRAINING

Packaged Service Training programs are an excellent way to increase your knowledge of the equipment discussed in this manual, including:

- Unit Familiarization • Maintenance
- Installation Overview • Operating Sequence

A large selection of product, theory, and skills programs is available, using popular video-based formats and materials. All include video and/or slides, plus companion book.

Classroom Service Training plus "hands-on" the products in our labs can mean increased confidence that really pays dividends in faster troubleshooting, fewer callbacks. Course descriptions and schedules are in our catalog.

CALL FOR FREE CATALOG 1-800-644-5544

[] Packaged Service Training [] Classroom Service Training

A94328