



United Technologies

Product Data

AquaForce® Fixed Speed Air-Cooled Liquid Chillers

80 to 500 Nominal Tons
(265 to 1740 Nominal kW)



30XA080-501
Fixed Speed Air-Cooled Liquid Chillers
with Optional Integrated Hydronic Pump Package

AquaForce® chillers were designed from the ground up to meet the efficiency demands of today and the future by providing premium air-cooled chiller packages for contractors, consulting engineers and building owners.

- Rotary screw compression
- R-134a HFC refrigerant
- Quiet AeroAcoustic™ fan system
- Novation® heat exchanger technology with microchannel coil
- Easy to use *ComfortLink* controls
- Optional integrated hydronic pump package, available with variable frequency drive (VFD)

AquaForce chillers' quiet operation make them ideal for sound sensitive applications

Great performance is delivered in a low sound unit that will be quiet enough for any application including hospitals, schools and other sites located in residential neighborhoods. In part load operation, such as cooler weather or night time duty, fewer fans operate. This results in even quieter operation.

Built in reliability

AquaForce chillers were developed under one of the most exacting qualification programs ever used for commercial chiller products. The compressors are virtually maintenance-free and protected by an auto-adaptive control that minimizes compressor wear. Operate AquaForce chillers year-round from -20°F (-29°C) to 125.6°F (52°C), with a combination of options and control methods. The following features are also provided to help ensure reliable performance:

Multiple independent circuits provide redundancy and greater reliability.

Electronic expansion valve (EXV) allows for precise control through all operating ranges.

Highly efficient, reliable chilled water circuit

AquaForce chillers provide a comprehensive chilled water circuit utilizing a high-efficiency shell-in-tube flooded cooler or an optional shell-in-tube DX (direct expansion) cooler. Units are equipped with a drainable cooler.

Electronic thermal-dispersion flow switch is included with the cooler. The switch is factory installed and tested and contains no moving parts for high reliability.

Optional integrated hydronic package is more than just a pump; it is an entire chilled water system, including:

- Single/dual pumps up to 15 hp and 140 ft head
- Available in constant speed or VFD configuration
- Strainer
- Start-up strainer (to be removed within 24 hours after chiller start-up)
- Flow regulator
- Freeze protection to -20°F (-29°C) (with freeze protection option)
- Heaters
- Required piping
- Pressure/temperature taps
- Isolation check valves for dual pump systems

The factory-installed and tested hydronic package provides faster, simpler and less expensive installation.

Environmentally balanced

Refrigerant R-134a enables the user to make a responsible choice in helping to preserve the environment. Refrigerant R-134a is an HFC refrigerant that does not contain ozone-layer damaging chlorine. This refrigerant is unaffected by the Montreal Protocol. It is a safe, non-toxic¹, efficient and environmentally balanced refrigerant.

Easy installation

A single chassis design (with the exception of the 30XA-501) provides a one-piece unit from 80 to 500 tons. The base rail is industrial-quality 7 ga for maximum structural integrity. The zinc-dipped galvanized frame (with Magni-coated screws) provides the best protection on the market for corrosion resistance. With such a structurally sound base, no perimeter base rail is needed.

ComfortLink controls for ease of use

The *ComfortLink* controls communicate in easy to understand English, making it as easy as possible to monitor and control each AquaForce chiller while accurately maintaining fluid temperatures. *ComfortLink* controls are available with French, Portuguese and Spanish as a standard configuration option.

Carrier's 30 Series chillers' *ComfortLink* controls provide features such as chilled water temperature reset, demand limiting, compressor wear minimization and protection, temperature and pressure displays and diagnostic functions. These controls result in higher chiller reliability, simplified training and more productive service calls with correspondingly lower operational and maintenance costs.

Two user interface options are available, the Touch Pilot™ display and the Navigator™ module. The Touch Pilot display is an easy to use touch screen display that provides simple navigation for configuration and control of AquaForce units.

Carrier's exclusive hand-held Navigator display provides convenience and powerful information in the palm of your hand. The Navigator display helps technicians to quickly diagnose problems and even prevent them from occurring. All AquaForce units are ready to be used with Carrier Comfort Network® (CCN) devices.

Table of contents

	Page
Features/Benefits	2
Model Number Nomenclature	4
Physical Data	6
Options and Accessories	24
Dimensions	27
Selection Procedure	88
Performance Data	90
Typical Piping and Wiring	94
Electrical Data	100
Controls	112
Control and Power Wiring Schematic	115
Application Data	119
Guide Specifications	128

1. Under ASHRAE Standard 34-1992, R-134a is classified as an A1 refrigerant.

A BACnet¹ communication option is also available for the i-Vu[®] Open control system or a third-party BACnet building automation system.

Seismic certification

A seismic kit is available which will result in a unit SDS (seismic design acceleration parameter) level of 2.4.

Novation[®] heat exchanger technology

The Novation heat exchanger design with microchannel (MCHX) condenser coil is a robust, cost effective alternative

to traditional coil design. These coils are offered coated or uncoated to match coil protection to site conditions. The e-coated version of this coil can withstand an 8000-hour salt spray test in accordance with ASTM (American Society for Testing and Materials) B-117 standard. The Carrier Electronic Catalog (E-CAT) can be used to determine whether corrosion protection is recommended for particular applications in coastal/marine environments.

Following the input of requested data, the E-CAT program output will advise the appropriate coil to be used. Other factors described in “Selection Guide: Environmental Corrosion Protection”

catalog number 04-581061-01 must also be considered to determine if corrosion protection is required.

Microchannel coils are sturdier than other coil types, making them easier to clean without damage to the coil.

Due to the compact all-aluminum design, microchannel coils will reduce overall unit operating weight by 6 to 7%. The streamlined MCHX coil design reduces refrigerant charge by up to 30%.

The coil is designed with rubber isolation around the powder painted coil frame to eliminate galvanic couples, which can cause corrosion due to dissimilar metals.

1. BACnet is a registered trademark of ASHRAE (American Society of Heating, Refrigerating, and Air-Conditioning Engineers).



TOUCH PILOT™ DISPLAY

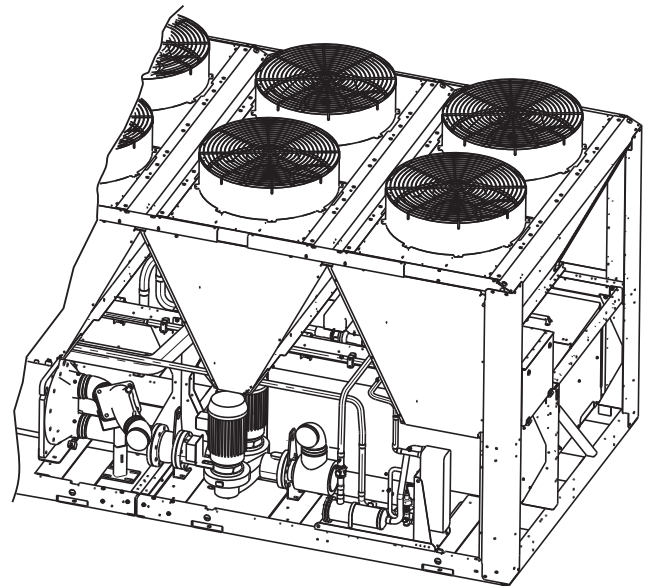

OPTIONAL PUMP PACKAGE (FLOODED COOLER SHOWN)

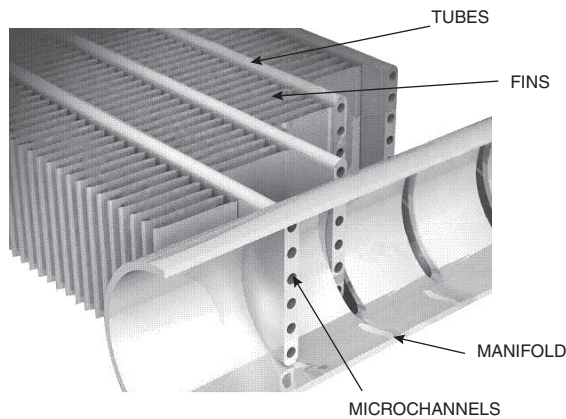

NOVATION[®] HEAT EXCHANGER TECHNOLOGY WITH MICROCHANNEL CONDENSER COILS

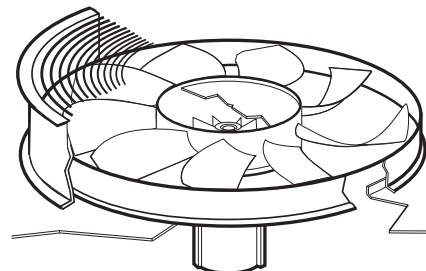

LOW-NOISE AEROACOUSTIC FAN

Model number nomenclature



30XA 3 200 6 F - 0 - - - L

30XA – AquaForce® Air-Cooled Chiller

Design Series

Unit Sizes*

080	102	140	182	240	282	350	501
082	110	142	200	242	300	352	
090	112	160	202	260	302	401	
092	120	162	220	262	325	451	
100	122	180	222	280	327	476	

Voltage

- 1 – 575-3-60 6 – 460-3-60
- 2 – 380-3-60 7 – 200-3-60
- 4 – 230-3-60

Condenser Coil/Ambient/Low Sound Options

- – Aluminum Fin/Copper Tube, High Ambient Temperature
- 0 – Copper Fin/Copper Tube, High Ambient Temperature
- 1 – Aluminum Pre-Coat Fin/Copper Tube, High Ambient Temperature
- 2 – Aluminum E-Coat Fin/Copper Tube, High Ambient Temperature
- 3 – Copper E-Coat Fin/Copper Tube, High Ambient Temperature
- 4 – Novation® Heat Exchanger (MCHX), High Ambient Temperature
- 5 – MCHX E-Coat, High Ambient Temperature
- 6 – Aluminum Fin/Copper Tube, High Ambient Temperature, Low Sound
- 7 – Copper Fin/Copper Tube, High Ambient Temperature, Low Sound
- 8 – Aluminum Pre-Coat Fin/Copper Tube, High Ambient Temperature, Low Sound
- 9 – Aluminum E-Coat Fin/Copper Tube, High Ambient Temperature, Low Sound
- B – Copper E-Coat Fin/Copper Tube, High Ambient Temperature, Low Sound
- C – MCHX, High Ambient Temperature, Low Sound
- D – MCHX E-Coat, High Ambient Temperature, Low Sound
- F – Aluminum Fin/Copper Tube, Standard Ambient Temperature, Low Sound
- G – Copper Fin/Copper Tube, Standard Ambient Temperature, Low Sound
- H – Aluminum Pre-Coat Fin/Copper Tube, Standard Ambient Temperature, Low Sound
- J – Aluminum E-Coated Fin/Copper Tube, Standard Ambient Temperature, Low Sound
- K – Copper E-Coat Fin/Copper Tube, Standard Ambient Temperature, Low Sound
- L – MCHX, Standard Ambient Temperature, Low Sound
- M – MCHX E-Coat, Standard Ambient Temperature, Low Sound
- N – Aluminum Fin/Copper Tube, Standard Ambient Temperature
- P – Copper Fin/Copper Tube, Standard Ambient Temperature
- Q – Aluminum Pre-Coat Fin/Copper Tube, Standard Ambient Temperature
- R – Aluminum E-Coat Fin/Copper Tube, Standard Ambient Temperature
- S – Copper E-Coat Fin/Copper Tube, Standard Ambient Temperature
- T – MCHX, Standard Ambient Temperature
- V – MCHX E-Coat, Standard Ambient Temperature

LEGEND

- CFSP – Coil Face Shipping Protection
- DX – Direct Expansion
- EMM – Energy Management Module
- LON – Local Operating Network
- SCCR – Short Circuit Current Rating
- VFD – Variable Frequency Drive
- XL – Across-the-Line Starter

* xx0, xx1, xx5, and xx6 size units contain flooded style evaporators. xx2 and xx7 size units contain direct expansion (DX) style evaporators.
 † Both flooded and DX cooler.
 ** Available in Middle East only.

**SEE NEXT PAGE
FOR REMAINDER
OF MODEL NUMBER
NOMENCLATURE**

Cooler Options

- – Cooler without Heater
- 0 – Cooler with Heater†
- 1 – DX Cooler with Heater, Hydronic Package
- 3 – Flooded Cooler with Heater, Minus One Pass
- 5 – Flooded Cooler with Heater, Plus One Pass
- 6 – DX Cooler without Heater, Hydronic Package
- 7 – Cooler with Heater, Full End Screen, Coil Trim Panels, Grilles†
- 8 – DX Cooler with Heater, Hydronic Package, Full End Screen, Coil Trim Panels, Grilles
- F – DX Cooler without Heater, Hydronic Package, Full End Screen, Coil Trim Panels, Grilles
- G – DX Cooler without Heater, Full End Screen, Coil Trim Panels, Grilles
- K – Flooded Cooler with Heater, Minus One Pass, Full End Screen, Coil Trim Panels, Grilles
- M – Flooded Cooler with Heater, Plus One Pass, Full End Screen, Coil Trim Panels, Grilles

Hydronic Pump Package Options

- – None
- 1 – Single Pump, 5 HP
- 2 – Single Pump, 7.5 HP
- 3 – Single Pump, 10 HP
- 4 – Single Pump, 15 HP
- 7 – Dual Pump, 5 HP
- 8 – Dual Pump, 7.5 HP
- B – Dual Pump, 10 HP
- C – Dual Pump, 15 HP
- G – Single Pump, 5 HP with VFD
- H – Single Pump, 7.5 HP with VFD
- J – Single Pump, 10 HP with VFD
- K – Single Pump, 15 HP with VFD
- N – Dual Pump, 5 HP with VFD
- P – Dual Pump, 7.5 HP with VFD
- Q – Dual Pump, 10 HP with VFD
- R – Dual Pump, 15 HP with VFD



Well exceeds ASHRAE 90.1 Standards.



DEALER DESIGN AWARDS



SEISMICOMPLIANT*

* Meets IBC 2006, ASCE-7-05, CBC 2007, and OSHPD seismic requirements.

Quality Assurance

ISO 9001:2008 certified processes

30XA 3 200 6 F - 0 - - - L

**SEE PREVIOUS PAGE
FOR REMAINDER
OF MODEL NUMBER
NOMENCLATURE**

Refrigeration Circuit Options

- - None
- 0 - Suction Line Insulation
- 1 - Isolation Valves
- 2 - Low Ambient Head Pressure Control
- 3 - Suction Line Insulation, Isolation Valves
- 4 - Suction Line Insulation, Low Ambient Head Pressure Control
- 5 - Isolation Valves, Low Ambient Head Pressure Control
- 6 - Suction Line Insulation, Isolation Valves, Head Pressure Control
- 7 - Minimum Load Control
- 8 - Suction Line Insulation, Minimum Load Control
- 9 - Isolation Valves, Minimum Load Control
- B - Low Ambient Head Pressure Control Operation, Minimum Load Control
- C - Suction Line Insulation, Isolation Valves, Minimum Load Control
- D - Suction Line Insulation, Head Pressure Control, Minimum Load Control
- F - Isolation Valves, Head Pressure Control, Minimum Load Control
- G - Suction Line Insulation, Isolation Valves, Head Pressure Control, Minimum Load Control
- H - None (High Ambient)**
- J - Suction Line Insulation (High Ambient)**
- K - Isolation Valve (High Ambient)**
- M - Suction Line Insulation (High Ambient), Isolation Valve (High Ambient)**
- R - Minimum Load Control (High Ambient)**
- S - Suction Line Insulation (High Ambient), Minimum Load Control (High Ambient)**
- T - Isolation Valve (High Ambient), Minimum Load Control (High Ambient)**
- W - Suction Line Insulation (High Ambient), Minimum Load Control (High Ambient), Isolation Valve (High Ambient)**

Electrical Options

- - Single Point Power, XL, Terminal Block, No Control Transformer
- 0 - Single Point Power, Wye-Delta, Terminal Block, No Control Transformer
- 3 - Dual Point Power, XL, Terminal Block, No Control Transformer
- 4 - Dual Point Power, Wye-Delta, Terminal Block, No Control Transformer
- 7 - Single Point Power, XL, Disconnect, No Control Transformer
- 8 - Single Point Power, Wye-Delta, Disconnect, No Control Transformer
- C - Dual Point Power, XL, Disconnect, No Control Transformer
- D - Dual Point Power, Wye-Delta, Disconnect, No Control Transformer
- H - Single Point Power, XL, Terminal Block, Control Transformer
- J - Single Point Power, Wye-Delta, Terminal Block, Control Transformer
- M - Dual Point Power, XL, Terminal Block, Control Transformer
- N - Dual Point Power, Wye-Delta, Terminal Block, Control Transformer
- R - Single Point Power, XL, Disconnect, Control Transformer
- S - Single Point Power, Wye-Delta, Disconnect, Control Transformer
- W - Dual Point Power, XL, Disconnect, Control Transformer
- X - Dual Point Power, Wye-Delta, Disconnect, Control Transformer

Packaging/Security/High SCCR Options

- 0 - Coil Face Shipping Protection (CFSP), Skid
- 1 - CFSP, Skid, Top Crate, Bag
- 3 - CFSP, Coil Trim Panels
- 4 - CFSP, Skid, Coil Trim Panels
- 5 - CFSP, Skid, Top Crate, Bag, Coil Trim Panels
- 7 - CFSP, Coil Trim Panels, Upper and Lower Grilles
- 8 - CFSP, Skid, Coil Trim Panels, Upper and Lower Grilles
- 9 - CFSP, Skid, Top Crate, Bag, Coil Trim Panels, Upper and Lower Grilles
- C - CFSP, Coil Trim Panels, Upper and Lower Grilles, Upper Hail Guards
- D - CFSP, Skid, Coil Trim Panels, Upper and Lower Grilles, Upper Hail Guards
- F - CFSP, Skid, Top Crate, Bag, Coil Trim Panels, Upper and Lower Grilles, Upper Hail Guards
- H - CFSP, Skid, High SCCR
- J - CFSP, Skid, Top Crate, Bag, High SCCR
- K - CFSP, High SCCR
- L - CFSP
- M - CFSP, Coil Trim Panels, High SCCR
- N - CFSP, Skid, Coil Trim Panels, High SCCR
- P - CFSP, Skid, Top Crate, Bag, Coil Trim Panels, High SCCR
- R - CFSP, Coil Trim Panels, Upper and Lower Grilles, High SCCR
- S - CFSP, Skid, Coil Trim Panels, Upper and Lower Grilles, High SCCR
- T - CFSP, Skid, Top Crate, Bag, Coil Trim Panels, Upper and Lower Grilles, High SCCR
- W - CFSP, Coil Trim Panels, Upper and Lower Grilles, Upper Hail Guards, High SCCR
- X - CFSP, Skid, Coil Trim Panels, Upper and Lower Grilles, Upper Hail Guards, High SCCR
- Y - CFSP, Skid, Top Crate, Bag, Coil Trim Panels, Upper and Lower Grilles, Upper Hail Guards, High SCCR

Controls/Communication Options

- - Navigator™ Display
- 0 - Navigator Display, EMM
- 1 - Navigator Display, Service Option
- 2 - Navigator Display, EMM, Service Option
- 3 - Touch Pilot™ Display
- 4 - Touch Pilot Display, EMM
- 5 - Touch Pilot Display, Service Option
- 6 - Touch Pilot Display, EMM, Service Option
- 7 - Navigator Display, BACnet/Modbus Translator
- 8 - Navigator Display, BACnet/Modbus Translator, EMM
- 9 - Navigator Display, BACnet/Modbus Translator, Service Option
- B - Navigator Display, BACnet/Modbus Translator, EMM, Service Option
- C - Touch Pilot Display, BACnet/Modbus Translator
- D - Touch Pilot Display, BACnet/Modbus Translator, EMM
- F - Touch Pilot Display, BACnet/Modbus Translator, Service Option
- G - Touch Pilot Display, BACnet/Modbus Translator, EMM, Service Option
- H - Navigator Display, LON Translator
- J - Navigator Display, LON Translator, EMM
- K - Navigator Display, LON Translator, Service Option
- L - Navigator Display, LON Translator, EMM, Service Option
- M - Touch Pilot Display, LON Translator
- N - Touch Pilot Display, LON Translator, EMM
- P - Touch Pilot Display, LON Translator, Service Option
- Q - Touch Pilot Display, LON Translator, EMM, Service Option
- R - Navigator Display, BACnet Communication
- S - Navigator Display, BACnet Communication, EMM
- V - Navigator Display, BACnet Communication, Service Option
- T - Navigator Display, BACnet Communication, EMM, Service Option
- W - Touch Pilot Display, BACnet Communication
- X - Touch Pilot Display, BACnet Communication, EMM
- Y - Touch Pilot Display, BACnet Communication, Service Option
- Z - Touch Pilot Display, BACnet Communication, EMM, Service Option

30XA080-122 — ENGLISH

Table with 10 columns (UNIT 30XA, 080, 082, 090, 092, 100, 102, 110, 112, 120, 122) and multiple rows detailing operating weight, refrigerant type, compressors, cooler, water connections, condenser fans, condenser coils, hydronic module, and chassis dimensions.

30XA140-220 — ENGLISH

Table with 10 columns (UNIT 30XA, 140, 142, 160, 162, 180, 182, 200, 202, 220) and multiple rows detailing operating weight, refrigerant type, compressors, cooler, water connections, condenser fans, condenser coils, hydronic module, and chassis dimensions.

LEGEND table listing symbols for Cu (Copper), Al (Aluminum), EXV (Electronic Expansion Valve), MCHX (Microchannel Heat Exchanger), and N/A (Not Applicable).

* Operating weight includes 2 pumps on models 30XA090-162. No pumps are available on 30XA080, 30XA082, or 30XA180-501. All weights include coil trim panels. See pages 10-23 for mounting weights for units without pumps and units with single pump packages.
† 30XA080,082 units do not have an economizer.
‡ The standard ambient temperature option is not available on 30XA401, 451, 476, and 501 units. The high ambient temperature option is not available on 30XA080-122 units.



30XA222-325 — ENGLISH

UNIT 30XA	222	240	242	260	262	280	282	300	302	325	
OPERATING WEIGHT (lb)*											
Al-Cu Condenser Coils	15,071	14,887	15,231	16,853	17,055	17,022	17,224	17,362	17,834	18,834	
Cu-Cu Condenser Coils	16,639	16,455	16,799	18,662	18,864	18,831	19,033	19,292	19,764	21,005	
MCHX Condenser Coils	14,092	13,897	14,241	15,720	15,922	15,878	16,080	16,141	16,613	17,467	
REFRIGERANT TYPE											
Refrigerant Charge (lb) Ckt A/Ckt B/Ckt C (RTPF)	246/198/—	270/270/—	246/246/—	375/220/—	R-134a, EXV Controlled System			330/256/—	415/270/—	386/261/—	375/375/—
Refrigerant Charge (lb) Ckt A/Ckt B/Ckt C (MCHX)	135/125/—	159.5/159/—	135/135/—	233.5/156/—	330/206/—	188/142/—	226.5/159.5/—	181/145/—	230/161/—	201/152/—	226.5/226.5/—
COMPRESSORS											
Quantity	2	2	2	2	2	2	2	2	2	2	
Speed (rpm)	3500				3500						
(Qty) Compressor Model Number Ckt A	(1) 06TT-356	(1) 06TT-356	(1) 06TT-356	(1) 06TU-483	(1) 06TU-483	(1) 06TU-483	(1) 06TU-483	(1) 06TU-483	(1) 06TU-554	(1) 06TU-554	(1) 06TU-483
(Qty) Compressor Model Number Ckt B	(1) 06TT-301	(1) 06TT-356	(1) 06TT-356	(1) 06TT-301	(1) 06TT-301	(1) 06TT-301	(1) 06TT-356	(1) 06TT-356	(1) 06TT-356	(1) 06TT-356	(1) 06TU-483
(Qty) Compressor Model Number Ckt C	N/A	N/A	N/A	N/A	N/A	N/A	N/A	N/A	N/A	N/A	N/A
Oil Charge (gal), Ckt A/Ckt B/Ckt C	6.75/6.25/—	6.75/6.75/—	6.75/6.75/—	7.5/6.75/—	7.5/6.75/—	7.5/6.75/—	7.5/6.75/—	7.5/6.75/—	7.5/6.75/—	7.5/6.75/—	7.5/7.5/—
Minimum Capacity Step (%)	14	15	15	11	11	13	13	12	12	15	
Standard	10	10	10	8	8	9	9	7	7	10	
Optional											
COOLER											
Net Fluid Volume (gal.)	71.0	39.0	71.0	42.0	82.8	44.0	82.8	48.5	108.0	50.5	
Maximum Refrigerant Pressure (psig)	220	220	220	220	220	220	220	220	220	220	
Maximum Water-Side Pressure without Pumps (psig)	300	300	300	300	300	300	300	300	300	300	
Maximum Water-Side Pressure with Pumps (psig)	—	—	—	—	—	—	—	—	—	—	
WATER CONNECTIONS											
Drain (NPT, in.)	3/4	3/8	3/4	3/8	3/4	3/8	3/4	3/8	3/4	3/8	
Standard, Inlet and Outlet, Victaulic (in.)	6	6	6	8	6	8	6	8	6	8	
Number of Passes	—	2	—	2	—	2	—	2	—	2	
Minus 1 Pass, Inlet and Outlet, Victaulic (in.)	—	8	—	8	—	8	—	8	—	8	
Number of Passes	—	1	—	1	—	1	—	1	—	1	
Plus 1 Pass, Inlet and Outlet, Victaulic (in.)	—	6	—	8	—	8	—	8	—	8	
Number of Passes	—	3	—	3	—	3	—	3	—	3	
CONDENSER FANS											
Fan Speed (rpm) Standard/High Ambient**	850/1140	850/1140	850/1140	850/1140	Shrouded Axial Type, Vertical Discharge			850/1140	850/1140	850/1140	
No. Blades...Diameter (in.)	9...30	9...30	9...30	9...30	850/1140	850/1140	850/1140	850/1140	850/1140	850/1140	
No. Fans (Ckt A/Ckt B/Ckt C)	7/6/—	7/6/—	7/6/—	9/6/—	9/6/—	9/6/—	9/7/—	10/6/—	10/6/—	9/9/—	
Total Airflow (cfm) 850 rpm	120,900	120,900	120,900	139,500	139,500	148,800	148,800	148,800	148,800	167,400	
Total Airflow (cfm) 1140 rpm	161,200	161,200	161,200	186,000	186,000	198,400	198,400	198,400	198,400	223,200	
CONDENSER COILS											
No. Coils (Ckt A/Ckt B/Ckt C)	7/6/—	7/6/—	7/6/—	9/6/—	9/6/—	9/7/—	9/7/—	10/6/—	10/6/—	9/9/—	
Total Face Area (sq ft)	305	305	305	352	352	375	375	375	375	422	
HYDRONIC MODULE (Optional) Pump											
	N/A										
CHASSIS DIMENSIONS (ft.-in.)											
Length	27-6						31-5			35-4	
Width											
Height											

30XA327-501 — ENGLISH

UNIT 30XA	327	350	352	401	451	476	501
OPERATING WEIGHT (lb)*							
Al-Cu Condenser Coils	19,306	19,040	19,512	22,688	23,423	27,518	29,882
Cu-Cu Condenser Coils	21,477	21,211	21,683	25,100	26,074	30,175	33,020
MCHX Condenser Coils	17,939	17,659	18,131	20,785	21,737	25,362	27,403
REFRIGERANT TYPE							
Refrigerant Charge (lb) Ckt A/Ckt B/Ckt C (RTPF)	344/344/—	415/375/—	384/344/—	460/385/—	530/385/—	475/465/—	560/495/—
Refrigerant Charge (lb) Ckt A/Ckt B/Ckt C (MCHX)	195/195/—	231.5/226.5/—	200/195/—	275/225/—	290/225/—	285/280/—	300/290/—
COMPRESSORS							
Quantity	2	2	2	2	2	2	2
Speed (rpm)	3500						
(Qty) Compressor Model Number Ckt A	(1) 06TU-483	(1) 06TU-554	(1) 06TU-554	(1) 06TV-680	(1) 06TV-819	(1) 06TV-753	(1) 06TV-819
(Qty) Compressor Model Number Ckt B	(1) 06TU-483	(1) 06TU-483	(1) 06TU-483	(1) 06TU-554	(1) 06TU-554	(1) 06TV-680	(1) 06TV-753
(Qty) Compressor Model Number Ckt C	N/A	N/A	N/A	N/A	N/A	N/A	N/A
Oil Charge (gal), Ckt A/Ckt B/Ckt C	7.5/7.5/—	7.5/7.5/—	7.5/7.5/—	7.5/7.5/—	7.5/7.5/—	7.5/7.5/—	7.5/7.5/—
Minimum Capacity Step (%)	15	15	15	15	12	15	15
Standard	10	10	10	10	8	11	11
Optional							
COOLER							
Net Fluid Volume (gal.)	108.0	53.4	108.0	64.5	64.5	81.8	81.8
Maximum Refrigerant Pressure (psig)	220	220	220	220	220	220	220
Maximum Water-Side Pressure without Pumps (psig)	300	300	300	300	300	300	300
Maximum Water-Side Pressure with Pumps (psig)	—	—	—	—	—	—	—
WATER CONNECTIONS							
Drain (NPT, in.)	3/4	3/8	3/4	3/8	3/8	3/8	3/8
Standard, Inlet and Outlet, Victaulic (in.)	6	8	6	8	8	8	8
Number of Passes	—	2	—	2	2	2	2
Minus 1 Pass, Inlet and Outlet, Victaulic (in.)	—	8	—	8	8	8	8
Number of Passes	—	1	—	1	1	1	1
Plus 1 Pass, Inlet and Outlet, Victaulic (in.)	—	8	—	—	—	—	—
Number of Passes	—	3	—	—	—	—	—
CONDENSER FANS							
Fan Speed (rpm) Standard/High Ambient**	850/1140	850/1140	850/1140	—/1140	—/1140	—/1140	—/1140
No. Blades...Diameter (in.)	9...30	9...30	9...30	9...30	9...30	9...30	9...30
No. Fans (Ckt A/Ckt B/Ckt C)	9/9/—	9/9/—	9/9/—	11/9/—	13/9/—	11/11/—	14/12/—
Total Airflow (cfm) 850 rpm	167,400	167,400	167,400	248,000	272,800	272,800	322,400
Total Airflow (cfm) 1140 rpm	223,200	223,200	223,200	248,000	272,800	272,800	322,400
CONDENSER COILS							
No. Coils (Ckt A/Ckt B/Ckt C)	9/9/—	9/9/—	9/9/—	11/9/—	13/9/—	11/11/—	14/12/—
Total Face Area (sq ft)	422	422	422	469	516	516	608
HYDRONIC MODULE (Optional) Pump							
	N/A						
CHASSIS DIMENSIONS (ft.-in.)							
Length	35-4		39-3		43-2		51-3
Width							
Height							

LEGEND

- Cu — Copper
- Al — Aluminum
- EXV — Electronic Expansion Valve
- MCHX — Microchannel Heat Exchanger
- N/A — Not Applicable

* Operating weight includes 2 pumps on models 30XA090-162. No pumps are available on 30XA080, 30XA082, or 30XA180-501. All weights include coil trim panels. See pages 10-23 for mounting weights for units without pumps and units with single pump packages.

† 30XA080,082 units do not have an economizer.

** The standard ambient temperature option is not available on 30XA401, 451, 476, and 501 units. The high ambient temperature option is not available on 30XA080-122 units.

UNIT MOUNTING WEIGHTS UNITS WITHOUT PUMPS AND WITH MCHX CONDENSER COILS — ENGLISH

30XA UNIT SIZE	MOUNTING WEIGHT (lb) MCHX CONDENSER COILS				
	A	B	C	D	Total
080	1947	1673	1670	1943	7234
082	1989	1709	1706	1985	7391

30XA UNIT SIZE	MOUNTING WEIGHT (lb) MCHX CONDENSER COILS						
	A	B	C	D	E	F	Total
090	1201	2043	750	951	1983	1199	8127
092	1219	2074	761	965	2013	1217	8251
100	1226	2098	780	981	2038	1224	8348
102	1244	2129	792	996	2068	1242	8472
110	1239	2136	798	1006	2075	1229	8483
112	1274	2196	820	1034	2133	1263	8720
120	1272	2174	800	1007	2106	1263	8622
122	1303	2227	819	1032	2157	1294	8832

30XA UNIT SIZE	MOUNTING WEIGHT (lb) MCHX CONDENSER COILS								
	A	B	C	D	E	F	G	H	Total
140	1897	1444	864	1181	1217	883	1584	1699	10,768
142	1977	1505	901	1231	1269	920	1651	1771	11,225
160	1949	1469	878	1206	1246	899	1603	1750	11,000
162	2024	1526	912	1253	1294	934	1665	1818	11,426

30XA UNIT SIZE	MOUNTING WEIGHT (lb) MCHX CONDENSER COILS										
	A	B	C	D	E	F	G	H	I	J	Total
180	905	1484	1164	1849	1187	1224	1868	840	1289	888	12,699
182	930	1524	1196	1899	1219	1257	1919	863	1324	912	13,044
200	909	1499	1188	1870	1192	1232	1879	848	1299	893	12,810
202	930	1534	1216	1914	1220	1261	1923	868	1330	914	13,112

30XA UNIT SIZE	MOUNTING WEIGHT (lb) MCHX CONDENSER COILS												
	A	B	C	D	E	F	G	H	I	J	K	L	Total
220	813	1196	1592	1498	828	1216	1259	848	1363	1064	1237	832	13,748
222	833	1226	1632	1535	849	1246	1290	869	1397	1091	1268	853	14,092
240	829	1218	1617	1520	830	1218	1261	850	1371	1073	1260	849	13,897
242	849	1248	1657	1558	851	1248	1292	871	1405	1100	1291	870	14,241
260	495	1431	1630	763	2465	1013	1528	2380	800	1333	1386	495	15,720
262	501	1449	1651	773	2497	1026	1548	2411	810	1350	1404	501	15,922
280	497	1451	1663	771	2497	1015	1530	2390	803	1358	1406	497	15,878
282	503	1469	1684	781	2529	1028	1549	2420	813	1375	1424	503	16,080
300	502	1465	1686	786	2568	1027	1557	2454	811	1367	1417	502	16,141
302	517	1508	1735	809	2643	1057	1602	2526	835	1407	1458	517	16,613

30XA UNIT SIZE	MOUNTING WEIGHT (lb) MCHX CONDENSER COILS														
	A	B	C	D	E	F	G	H	I	J	K	L	M	N	Total
325	742	742	978	1531	783	2546	1067	1563	2334	804	1646	1247	742	742	17,467
327	762	762	1004	1572	804	2615	1096	1605	2397	826	1690	1281	762	762	17,939
350	745	745	982	1546	792	2598	1077	1589	2386	808	1651	1249	745	745	17,659
352	765	765	1008	1587	813	2667	1106	1631	2450	830	1695	1282	765	765	18,131

30XA UNIT SIZE	MOUNTING WEIGHT (lb) MCHX CONDENSER COILS																
	A	B	C	D	E	F	G	H	I	J	K	L	M	N	O	P	Total
401	1471	1827	1921	2057	2134	1154	579	579	579	579	1950	1902	971	971	1147	964	20,785
451	524	683	3121	3060	2130	858	978	1085	1705	1974	762	1017	1193	1281	842	524	21,737
476	725	1000	3556	4035	2626	913	998	1105	1720	1988	784	1127	1339	1446	1214	786	25,362
501A	1639	2120	2616	2829	2616	1237	826	610	610	610	785	2070	2340	1126	1448	915	24,397
501B	631	812	631	—	—	—	—	—	—	—	—	—	—	—	—	—	3,006

LEGEND

MCHX — Microchannel Heat Exchanger

NOTE: Size 501 ships as two modules. The 501A and 501B modules are installed as one chiller.

UNIT MOUNTING WEIGHTS (cont)
UNITS WITHOUT PUMPS AND WITH MCHX CONDENSER COILS — SI

30XA UNIT SIZE	MOUNTING WEIGHT (kg) MCHX CONDENSER COILS																
	A	B	C	D	Total												
080	883	759	758	882	3281												
082	902	775	774	900	3353												
30XA UNIT SIZE	MOUNTING WEIGHT (kg) MCHX CONDENSER COILS																
	A	B	C	D	E	F	Total										
090	545	927	340	431	899	544	3686										
092	553	941	345	438	913	552	3742										
100	556	952	354	445	924	555	3786										
102	564	966	359	452	938	563	3843										
110	562	969	362	456	941	558	3848										
112	578	996	372	469	968	573	3955										
120	577	986	363	457	955	573	3911										
122	591	1010	372	468	979	587	4006										
30XA UNIT SIZE	MOUNTING WEIGHT (kg) MCHX CONDENSER COILS																
	A	B	C	D	E	F	G	H	Total								
140	860	655	392	536	552	401	719	771	4884								
142	897	683	409	558	575	418	749	803	5091								
160	884	666	398	547	565	408	727	794	4990								
162	918	692	414	568	587	424	755	825	5183								
30XA UNIT SIZE	MOUNTING WEIGHT (kg) MCHX CONDENSER COILS																
	A	B	C	D	E	F	G	H	I	J	Total						
180	410	673	528	839	538	555	847	381	584	403	5760						
182	422	691	542	861	553	570	870	391	601	414	5917						
200	412	680	539	848	541	559	852	385	589	405	5811						
202	422	696	552	868	553	572	872	394	603	415	5948						
30XA UNIT SIZE	MOUNTING WEIGHT (kg) MCHX CONDENSER COILS																
	A	B	C	D	E	F	G	H	I	J	K	L	Total				
220	369	542	722	680	376	552	571	385	618	483	561	378	6236				
222	378	556	740	696	385	565	585	394	634	495	575	387	6392				
240	376	552	734	690	377	553	572	386	622	487	572	385	6304				
242	385	566	752	707	386	566	586	395	637	499	586	395	6460				
260	225	649	740	346	1118	460	693	1079	363	605	629	225	7130				
262	227	657	749	351	1132	465	702	1093	368	612	637	227	7222				
280	225	658	754	350	1133	461	694	1084	364	616	638	225	7202				
282	228	667	764	354	1147	466	703	1098	369	624	646	228	7294				
300	228	664	765	357	1165	466	706	1113	368	620	643	228	7322				
302	234	684	787	367	1199	479	727	1146	379	638	662	234	7535				
30XA UNIT SIZE	MOUNTING WEIGHT (kg) MCHX CONDENSER COILS																
	A	B	C	D	E	F	G	H	I	J	K	L	M	N	Total		
325	337	337	444	695	355	1155	484	709	1058	365	746	565	337	337	7923		
327	346	346	456	713	365	1186	497	728	1087	375	767	581	346	346	8137		
350	338	338	446	701	359	1179	488	721	1082	367	749	567	338	338	8010		
352	347	347	457	720	369	1210	502	740	1111	376	769	582	347	347	8224		
30XA UNIT SIZE	MOUNTING WEIGHT (kg) MCHX CONDENSER COILS																
	A	B	C	D	E	F	G	H	I	J	K	L	M	N	O	P	Total
401	667	829	871	933	968	523	262	262	262	262	885	863	440	440	520	437	9 424
451	238	310	1416	1388	966	389	443	492	773	895	346	461	541	581	382	238	9 859
476	329	418	1488	1689	1099	382	418	463	720	832	328	472	561	605	508	329	10 641
501A	683	884	1091	1180	1091	516	345	255	255	255	328	863	976	470	604	381	10 177
501B	286	368	423	286	—	—	—	—	—	—	—	—	—	—	—	—	1 364

LEGEND

MCHX — Microchannel Heat Exchanger

NOTE: Size 501 ships as two modules. The 501A and 501B modules are installed as one chiller.

UNIT MOUNTING WEIGHTS (cont) UNITS WITHOUT PUMPS AND WITH MCHX CONDENSER COILS

30XA080, 082

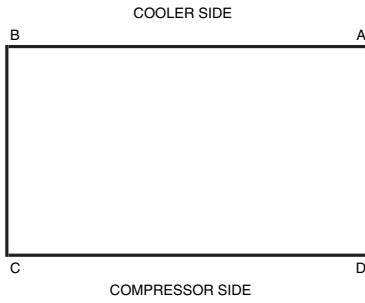

30XA220-302

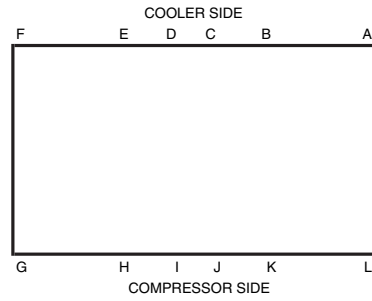

30XA090-122

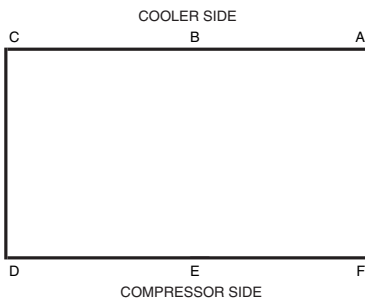

30XA325-352

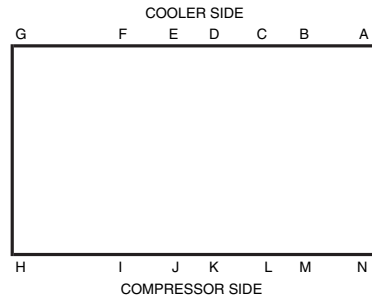

30XA140-162

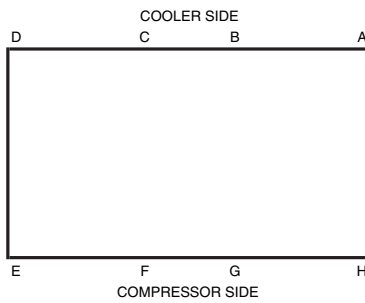

30XA401-501A

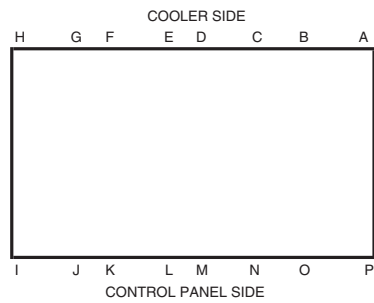

30XA180-202

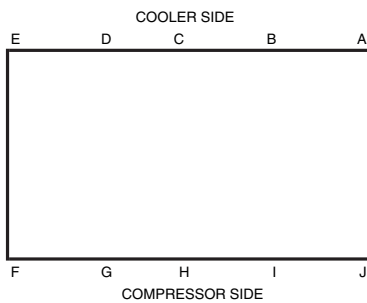

30XA501B

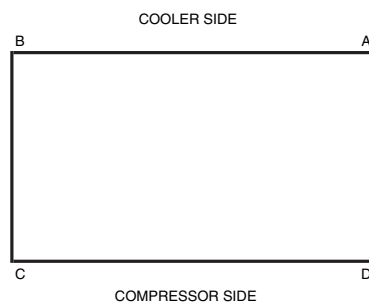

LEGEND

MCHX — Microchannel Heat Exchanger

NOTE: Size 501 ships as two modules. The 501A and 501B modules are installed as one chiller.

**UNIT MOUNTING WEIGHTS (cont)
DUAL PUMP UNITS WITH MCHX CONDENSER COILS — ENGLISH**

30XA UNIT SIZE	MOUNTING WEIGHT (lb) MCHX CONDENSER COILS						
	A	B	C	D	E	F	Total
090	1201	2962	1176	900	1944	1199	9,382
092	1217	3001	1192	912	1970	1215	9,506
100	1226	3022	1212	924	1995	1224	9,603
102	1242	3061	1228	936	2021	1240	9,727
110	1239	3064	1234	945	2027	1229	9,738
112	1269	3139	1264	968	2076	1259	9,975
120	1272	3101	1236	947	2059	1263	9,877
122	1299	3167	1262	967	2103	1290	10,087

30XA UNIT SIZE	MOUNTING WEIGHT (lb) MCHX CONDENSER COILS								
	A	B	C	D	E	F	G	H	Total
140	1897	1444	1818	1694	1078	810	1584	1699	12,023
142	1969	1499	1887	1758	1119	841	1644	1764	12,480
160	1949	1469	1834	1724	1103	824	1603	1750	12,255
162	2017	1520	1898	1784	1141	853	1659	1811	12,681

DUAL PUMP UNITS WITH MCHX CONDENSER COILS — SI

30XA UNIT SIZE	MOUNTING WEIGHT (kg) MCHX CONDENSER COILS						
	A	B	C	D	E	F	Total
090	545	1343	533	408	882	544	4255
092	552	1361	540	414	893	551	4312
100	556	1371	550	419	905	555	4356
102	563	1388	557	425	917	562	4412
110	562	1390	560	429	920	558	4417
112	576	1424	573	439	942	571	4525
120	577	1407	560	430	934	573	4480
122	589	1436	573	439	954	585	4575

30XA UNIT SIZE	MOUNTING WEIGHT (kg) MCHX CONDENSER COILS								
	A	B	C	D	E	F	G	H	Total
140	860	655	825	769	489	367	719	771	5454
142	893	680	856	798	508	381	746	800	5661
160	884	666	832	782	500	374	727	794	5559
162	915	689	861	809	518	387	752	821	5752

30XA090-122

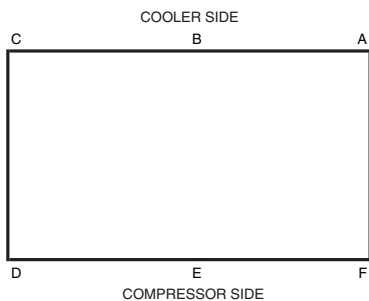

30XA140-162

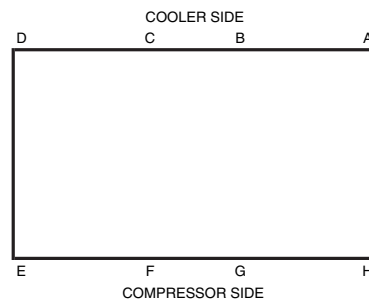

LEGEND

MCHX — Microchannel Heat Exchanger

UNIT MOUNTING WEIGHTS (cont) UNITS WITHOUT PUMPS AND WITH Al/Cu CONDENSER COILS — ENGLISH

30XA UNIT SIZE	MOUNTING WEIGHT (lb) — Al/Cu*																
	A	B	C	D	Total												
080	2059	1785	1778	2051	7674												
082	2101	1822	1814	2093	7831												
30XA UNIT SIZE	MOUNTING WEIGHT (lb) — Al/Cu*																
	A	B	C	D	E	F	Total										
090	1273	2188	822	1023	2127	1271	8704										
092	1291	2219	834	1038	2157	1289	8828										
100	1299	2244	853	1054	2184	1297	8931										
102	1317	2275	865	1069	2214	1315	9055										
110	1312	2284	872	1079	2222	1303	9071										
112	1346	2344	895	1107	2280	1337	9308										
120	1346	2322	874	1082	2255	1337	9216										
122	1377	2375	894	1107	2306	1367	9426										
30XA UNIT SIZE	MOUNTING WEIGHT (lb) — Al/Cu*																
	A	B	C	D	E	F	G	H	Total								
140	2007	1554	938	1254	1291	957	1695	1809	11,505								
142	2087	1616	975	1304	1342	995	1762	1881	11,962								
160	2061	1581	953	1281	1321	974	1715	1862	11,748								
162	2136	1638	988	1327	1369	1009	1777	1930	12,174								
30XA UNIT SIZE	MOUNTING WEIGHT (lb) — Al/Cu*																
	A	B	C	D	E	F	G	H	I	J	Total						
180	979	1558	1239	1998	1261	1298	2016	915	1363	962	13,590						
182	1004	1598	1270	2049	1293	1331	2067	938	1398	986	13,935						
200	984	1574	1263	2020	1267	1308	2029	923	1375	968	13,712						
202	106	1609	1291	2065	1295	1337	2074	943	1405	989	14,014						
30XA UNIT SIZE	MOUNTING WEIGHT (lb) — Al/Cu*																
	A	B	C	D	E	F	G	H	I	J	K	L	Total				
220	883	1266	1697	1603	898	1286	1329	918	1468	1169	1307	902	14,727				
222	904	1296	1737	1640	919	1316	1360	939	1502	1196	1337	923	15,071				
240	900	1288	1723	1626	901	1289	1331	921	1477	1179	1331	920	14,887				
242	921	1318	1763	1664	922	1319	1362	942	1511	1206	1362	941	15,231				
260	566	1572	1701	834	2607	1084	1599	2521	871	1404	1528	566	16,853				
262	573	1591	1721	844	2638	1097	1618	2551	881	1421	1546	573	17,055				
280	569	1594	1734	843	2640	1087	1601	2533	875	1429	1549	569	17,022				
282	576	1613	1755	853	2671	1100	1620	2563	885	1446	1567	576	17,224				
300	578	1617	1762	862	2720	1103	1633	2607	887	1444	1570	578	17,362				
302	594	1661	1810	885	2794	1133	1677	2678	911	1483	1613	594	17,834				
30XA UNIT SIZE	MOUNTING WEIGHT (lb) — Al/Cu*																
	A	B	C	D	E	F	G	H	I	J	K	L	M	N	Total		
325	856	856	1054	1607	859	2697	1143	1639	2485	880	1722	1322	856	856	18,834		
327	877	877	1080	1647	881	2765	1172	1680	2547	902	1765	1355	877	877	19,306		
350	860	860	1059	1623	869	2752	1153	1666	2539	885	1727	1326	860	860	19,040		
352	881	881	1085	1663	891	2820	1182	1707	2602	907	1770	1359	881	881	19,512		
30XA UNIT SIZE	MOUNTING WEIGHT (lb) — Al/Cu*																
	A	B	C	D	E	F	G	H	I	J	K	L	M	N	O	P	Total
401	1599	1960	2056	2194	2272	1278	667	667	667	667	2085	2036	1092	1092	1271	1085	22,688
451	597	758	3260	3198	2254	962	1084	1193	1822	2095	865	1124	1303	1392	919	597	23,423
476	916	1133	3709	4195	2767	1032	1118	1227	1850	2121	901	1248	1464	1571	1350	916	27,518
501A	1767	2255	2757	2973	2757	1360	917	699	699	699	903	2204	2478	1248	1574	1034	26,324
501B	747	961	1103	747	—	—	—	—	—	—	—	—	—	—	—	—	3,558

*Condenser Coil: Aluminum Fins/Copper Tubing.

NOTE: Size 501 ships as two modules. The 501A and 501B modules are installed as one chiller.

UNIT MOUNTING WEIGHTS (cont)
UNITS WITHOUT PUMPS AND WITH Al/Cu CONDENSER COILS — SI

30XA UNIT SIZE	MOUNTING WEIGHT (kg) — Al/Cu*																
	A	B	C	D	Total												
080	934	810	807	930	3481												
082	953	826	823	949	3552												
30XA UNIT SIZE	MOUNTING WEIGHT (kg) — Al/Cu*																
	A	B	C	D	E	F	Total										
090	578	992	373	464	965	576	3948										
092	586	1007	378	471	979	585	4004										
100	589	1018	387	478	991	588	4051										
102	597	1032	392	485	1004	596	4107										
110	595	1036	396	489	1008	591	4115										
112	611	1063	406	502	1034	606	4222										
120	611	1053	397	491	1023	607	4181										
122	624	1077	405	502	1046	620	4276										
30XA UNIT SIZE	MOUNTING WEIGHT (kg) — Al/Cu*																
	A	B	C	D	E	F	G	H	Total								
140	910	705	425	569	585	434	769	821	5219								
142	946	733	442	591	609	451	799	853	5426								
160	935	717	432	581	599	442	778	845	5329								
162	969	743	448	602	621	458	806	875	5522								
30XA UNIT SIZE	MOUNTING WEIGHT (kg) — Al/Cu*																
	A	B	C	D	E	F	G	H	I	J	Total						
180	444	707	562	906	572	589	915	415	618	436	6164						
182	455	725	576	929	586	604	938	426	634	447	6321						
200	446	714	573	916	575	593	920	419	624	439	6220						
202	456	730	586	936	587	606	941	428	637	449	6357						
30XA UNIT SIZE	MOUNTING WEIGHT (kg) — Al/Cu*																
	A	B	C	D	E	F	G	H	I	J	K	L	Total				
220	401	574	770	727	407	583	603	416	666	530	593	409	6680				
222	410	588	788	744	417	597	617	426	681	543	607	419	6836				
240	408	584	782	738	409	585	604	418	670	535	604	417	6753				
242	418	598	800	755	418	598	618	427	685	547	618	427	6909				
260	257	713	772	378	1182	492	725	1144	395	637	693	257	7644				
262	260	722	781	383	1197	498	734	1157	400	644	701	260	7736				
280	258	723	787	382	1197	493	726	1149	397	648	703	258	7721				
282	261	732	796	387	1212	499	735	1163	402	656	711	261	7813				
300	262	734	799	391	1234	501	741	1182	402	655	712	262	7876				
302	269	753	821	402	1267	514	761	1215	413	673	731	269	8089				
30XA UNIT SIZE	MOUNTING WEIGHT (kg) — Al/Cu*																
	A	B	C	D	E	F	G	H	I	J	K	L	M	N	Total		
325	388	388	478	729	390	1224	518	744	1127	399	781	600	388	388	8543		
327	398	398	490	747	399	1254	531	762	1155	409	801	615	398	398	8757		
350	390	390	480	736	394	1248	523	756	1152	401	784	601	390	390	8636		
352	400	400	492	754	404	1279	536	774	1180	411	803	616	400	400	8850		
30XA UNIT SIZE	MOUNTING WEIGHT (kg) — Al/Cu*																
	A	B	C	D	E	F	G	H	I	J	K	L	M	N	O	P	Total
401	725	889	933	995	1030	580	303	303	303	303	946	924	495	495	576	492	10 292
451	271	344	1479	1450	1022	436	492	541	826	950	393	510	591	631	417	271	10 624
476	416	514	1682	1903	1255	468	507	556	839	962	409	566	664	713	612	416	12 482
501A	802	1023	1251	1349	1251	617	416	317	317	317	410	1000	1124	566	714	469	11 943
501B	339	436	500	339	—	—	—	—	—	—	—	—	—	—	—	—	1 614

*Condenser Coil: Aluminum Fins/Copper Tubing.

NOTE: Size 501 ships as two modules. The 501A and 501B modules are installed as one chiller.

UNIT MOUNTING WEIGHTS (cont) UNITS WITHOUT PUMPS AND WITH Al/Cu CONDENSER COILS

30XA080, 082

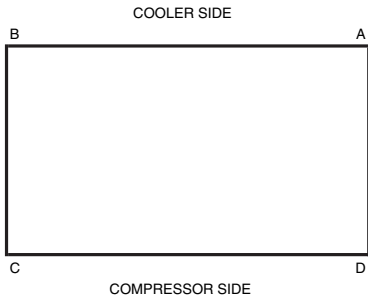

30XA220-302

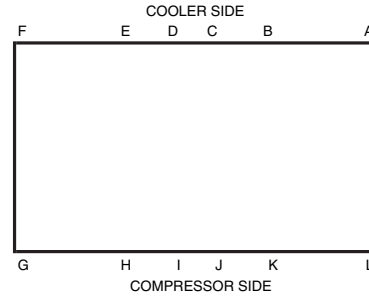

30XA090-122

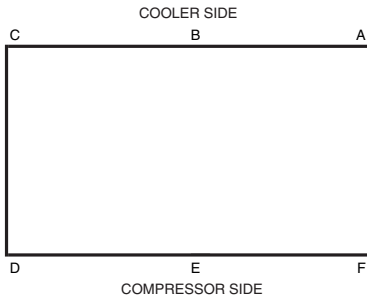

30XA325-352

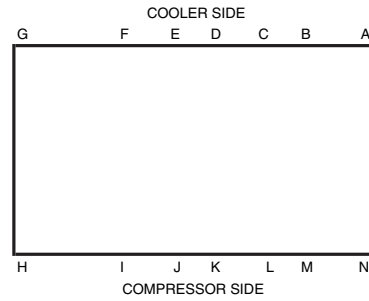

30XA140-162

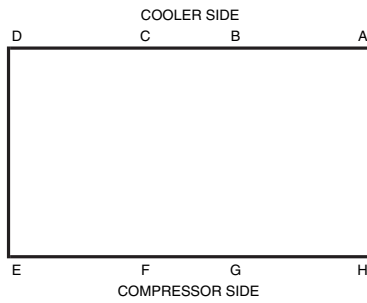

30XA401-501A

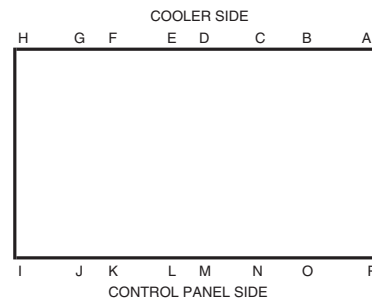

30XA180-202

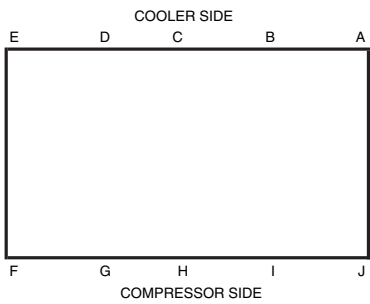

30XA501B

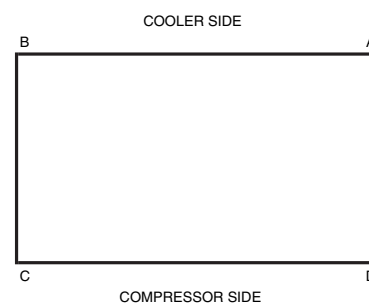

NOTE: Size 501 ships as two modules. The 501A and 501B modules are installed as one chiller.

**UNIT MOUNTING WEIGHTS (cont)
SINGLE PUMP UNITS WITH Al/Cu CONDENSER COILS — ENGLISH**

30XA UNIT SIZE	MOUNTING WEIGHT (lb) — Al/Cu*						
	A	B	C	D	E	F	Total
090	1273	2898	1160	972	2089	1271	9,662
092	1289	2935	1175	984	2116	1287	9,786
100	1299	2959	1196	997	2140	1297	9,889
102	1315	2996	1211	1009	2167	1313	10,013
110	1312	3002	1219	1019	2175	1303	10,029
112	1343	3073	1248	1043	2226	1334	10,266
120	1346	3041	1221	1021	2208	1337	10,174
122	1374	3104	1246	1042	2254	1365	10,384

30XA UNIT SIZE	MOUNTING WEIGHT (lb) — Al/Cu*								
	A	B	C	D	E	F	G	H	Total
140	2007	1554	1683	1679	1152	883	1695	1809	12,463
142	2081	1611	1745	1740	1194	915	1757	1875	12,920
160	2061	1581	1701	1710	1178	898	1715	1862	12,706
162	2130	1634	1758	1767	1218	928	1773	1924	13,132

SINGLE PUMP UNITS WITH Al/Cu CONDENSER COILS — SI

30XA UNIT SIZE	MOUNTING WEIGHT (kg) — Al/Cu*						
	A	B	C	D	E	F	Total
090	578	1314	526	441	947	576	4383
092	585	1331	533	447	960	584	4439
100	589	1342	543	452	971	588	4485
102	597	1359	549	458	983	596	4542
110	595	1362	553	462	986	591	4549
112	609	1394	566	473	1010	605	4657
120	611	1379	554	463	1001	607	4615
122	623	1408	565	473	1022	619	4710

30XA UNIT SIZE	MOUNTING WEIGHT (kg) — Al/Cu*								
	A	B	C	D	E	F	G	H	Total
140	910	705	763	762	523	401	769	821	5653
142	944	731	791	789	542	415	797	851	5860
160	935	717	771	776	534	408	778	845	5763
162	966	741	797	802	552	421	804	873	5957

*Condenser Coil: Aluminum Fins/Copper Tubing.

30XA090-122

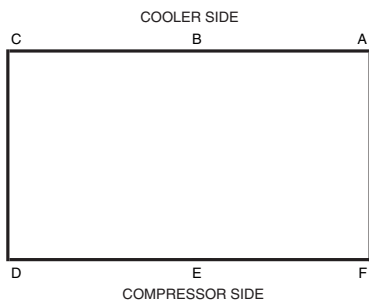

30XA140-162

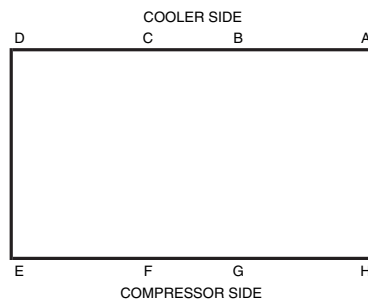

UNIT MOUNTING WEIGHTS (cont) DUAL PUMP UNITS WITH Al/Cu CONDENSER COILS — ENGLISH

30XA UNIT SIZE	MOUNTING WEIGHT (lb) — Al/Cu*						
	A	B	C	D	E	F	Total
090	1273	3106	1248	972	2089	1271	9,959
092	1289	3145	1264	984	2115	1287	10,083
100	1299	3168	1285	997	2140	1297	10,186
102	1315	3206	1301	1009	2166	1313	10,310
110	1312	3211	1307	1019	2175	1303	10,326
112	1342	3285	1337	1042	2225	1333	10,563
120	1346	3249	1310	1021	2208	1337	10,471
122	1373	3314	1336	1041	2252	1364	10,681

30XA UNIT SIZE	MOUNTING WEIGHT (lb) — Al/Cu*								
	A	B	C	D	E	F	G	H	Total
140	2007	1554	1891	1768	1152	883	1695	1809	12,760
142	2079	1610	1959	1831	1193	915	1756	1874	13,217
160	2061	1581	1909	1799	1178	898	1715	1862	13,003
162	2129	1633	1972	1858	1217	927	1771	1923	13,429

DUAL PUMP UNITS WITH Al/Cu CONDENSER COILS — SI

30XA UNIT SIZE	MOUNTING WEIGHT (kg) — Al/Cu*						
	A	B	C	D	E	F	Total
090	578	1409	566	441	947	576	4517
092	585	1426	573	446	959	584	4573
100	589	1437	583	452	971	588	4620
102	596	1454	590	458	982	595	4676
110	595	1456	593	462	986	591	4684
112	609	1490	606	473	1009	605	4791
120	611	1474	594	463	1001	607	4750
122	623	1503	606	472	1022	619	4845

30XA UNIT SIZE	MOUNTING WEIGHT (kg) — Al/Cu*								
	A	B	C	D	E	F	G	H	Total
140	910	705	858	802	523	401	769	821	5788
142	943	730	888	831	541	415	796	850	5995
160	935	717	866	816	534	408	778	845	5898
162	965	741	894	843	552	421	803	872	6091

*Condenser Coil: Aluminum Fins/Copper Tubing.

30XA090-122

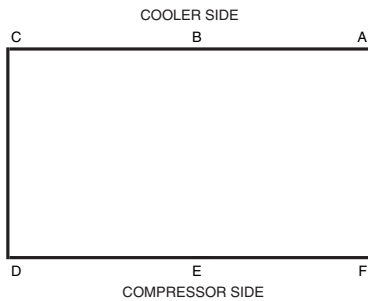

30XA140-162

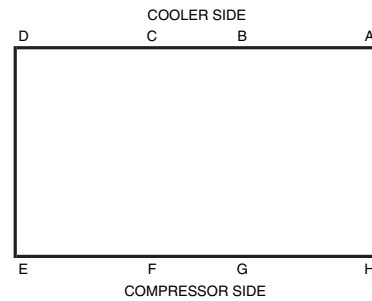

UNIT MOUNTING WEIGHTS (cont)
UNITS WITHOUT PUMPS AND WITH Cu/Cu CONDENSER COILS — ENGLISH

30XA UNIT SIZE	MOUNTING WEIGHT (lb) — Cu/Cu†																
	A	B	C	D	Total												
080	2244	1970	1956	2228	8398												
082	2286	2007	1993	2270	8555												
30XA UNIT SIZE	MOUNTING WEIGHT (lb) — Cu/Cu†																
	A	B	C	D	E	F	Total										
090	1394	2429	943	1144	2368	1392	9,669										
092	1412	2460	955	1159	2398	1410	9,793										
100	1420	2485	974	1174	2425	1418	9,896										
102	1438	2516	986	1189	2455	1436	10,020										
110	1433	2525	993	1200	2463	1424	10,036										
112	1467	2585	1016	1228	2521	1458	10,273										
120	1467	2563	995	1202	2496	1458	10,181										
122	1497	2616	1016	1227	2547	1488	10,391										
30XA UNIT SIZE	MOUNTING WEIGHT (lb) — Cu/Cu†																
	A	B	C	D	E	F	G	H	Total								
140	2188	1735	1058	1375	1411	1078	1876	1990	12,711								
142	2267	1797	1096	1424	1462	1117	1943	2061	13,168								
160	2242	1762	1074	1401	1442	1095	1896	2043	12,954								
162	2316	1820	1109	1447	1489	1131	1958	2110	13,380								
30XA UNIT SIZE	MOUNTING WEIGHT (lb) — Cu/Cu†																
	A	B	C	D	E	F	G	H	I	J	Total						
180	1099	1679	1359	2239	1382	1419	2258	1035	1483	1083	15,037						
182	1124	1717	1390	2290	1414	1452	2310	1059	1517	1108	15,382						
200	1105	1695	1384	2261	1388	1428	2271	1044	1495	1089	15,159						
202	1127	1729	1412	2306	1416	1456	2316	1065	1525	1111	15,461						
30XA UNIT SIZE	MOUNTING WEIGHT (lb) — Cu/Cu†																
	A	B	C	D	E	F	G	H	I	J	K	L	Total				
220	995	1378	1865	1771	1010	1398	1441	1030	1636	1337	1419	1014	16,295				
222	1016	1407	1904	1808	1031	1427	1471	1052	1671	1365	1449	1035	16,639				
240	1012	1400	1891	1794	1013	1401	1443	1033	1645	1347	1443	1032	16,455				
242	1033	1429	1930	1831	1034	1430	1473	1055	1679	1375	1473	1054	16,799				
260	679	1798	1814	947	2833	1197	1712	2748	984	1517	1754	679	18,662				
262	686	1817	1834	957	2864	1210	1730	2778	995	1533	1773	686	18,864				
280	682	1820	1847	956	2866	1200	1715	2759	988	1542	1775	682	18,831				
282	689	1839	1867	966	2897	1213	1733	2789	999	1559	1794	689	19,033				
300	699	1858	1883	983	2962	1224	1754	2848	1008	1564	1811	699	19,292				
302	716	1903	1929	1007	3034	1254	1797	2918	1033	1602	1855	716	19,764				
30XA UNIT SIZE	MOUNTING WEIGHT (lb) — Cu/Cu†																
	A	B	C	D	E	F	G	H	I	J	K	L	M	N	Total		
325	1037	1037	1175	1728	980	2939	1263	1760	2727	1001	1842	1443	1037	1037	21,005		
327	1060	1060	1201	1767	1002	3005	1291	1800	2788	1023	1883	1475	1060	1060	21,477		
350	1041	1041	1180	1743	990	2993	1274	1786	2780	1006	1848	1447	1041	1041	21,211		
352	1064	1064	1206	1782	1012	3060	1302	1826	2842	1028	1889	1479	1064	1064	21,683		
30XA UNIT SIZE	MOUNTING WEIGHT (lb) — Cu/Cu†																
	A	B	C	D	E	F	G	H	I	J	K	L	M	N	O	P	Total
401	1759	2118	2213	2350	2428	1440	791	791	791	791	2242	2193	1256	1256	1433	1248	25,100
451	736	897	3424	3362	2424	1142	1263	1372	1996	2268	1046	1302	1480	1569	1057	736	26,074
476	1103	1319	3858	4341	2922	1196	1282	1390	2010	2279	1067	1412	1626	1733	1534	1103	30,175
501A	1928	2413	2913	3127	2913	1523	1040	823	823	823	1069	2363	2634	1412	1736	1199	33,020
501B	899	1156	1327	899	—	—	—	—	—	—	—	—	—	—	—	—	4,282

†Condenser Coil: Copper Fins/Copper Tubing.

NOTE: Size 501 ships as two modules. The 501A and 501B modules are installed as one chiller.

UNIT MOUNTING WEIGHTS (cont) UNITS WITHOUT PUMPS AND WITH Cu/Cu CONDENSER COILS — SI

30XA UNIT SIZE	MOUNTING WEIGHT (kg) — Cu/Cu†				
	A	B	C	D	Total
080	1018	893	887	1011	3809
082	1037	910	904	1030	3881

30XA UNIT SIZE	MOUNTING WEIGHT (kg) — Cu/Cu†						
	A	B	C	D	E	F	Total
090	632	1102	428	519	1074	631	4386
092	640	1116	433	526	1088	639	4442
100	644	1127	442	533	1100	643	4489
102	652	1141	447	539	1114	651	4545
110	650	1145	450	544	1117	646	4552
112	665	1172	461	557	1144	661	4660
120	665	1163	451	545	1132	661	4618
122	679	1187	461	556	1156	675	4713

30XA UNIT SIZE	MOUNTING WEIGHT (kg) — Cu/Cu†								
	A	B	C	D	E	F	G	H	Total
140	992	787	480	624	640	489	851	903	5766
142	1028	815	497	646	663	507	881	935	5973
160	1017	799	487	636	654	497	860	927	5876
162	1050	826	503	656	676	513	888	957	6069

30XA UNIT SIZE	MOUNTING WEIGHT (kg) — Cu/Cu†										
	A	B	C	D	E	F	G	H	I	J	Total
180	499	762	617	1016	627	644	1024	470	673	491	6821
182	510	779	631	1039	641	658	1048	480	688	503	6977
200	501	769	628	1026	630	648	1030	474	678	494	6876
202	511	784	640	1046	642	661	1051	483	692	504	7013

30XA UNIT SIZE	MOUNTING WEIGHT (kg) — Cu/Cu†												
	A	B	C	D	E	F	G	H	I	J	K	L	Total
220	451	625	846	804	458	634	653	467	742	607	644	460	7391
222	461	638	864	820	468	648	667	477	758	619	657	470	7547
240	459	635	858	814	460	635	655	469	746	611	654	468	7464
242	469	648	876	831	469	649	668	478	762	624	668	478	7620
260	308	816	823	429	1285	543	777	1246	446	688	796	308	8465
262	311	824	832	434	1299	549	785	1260	451	696	804	311	8557
280	309	826	838	434	1300	544	778	1252	448	700	805	309	8542
282	313	834	847	438	1314	550	786	1265	453	707	814	313	8633
300	317	843	854	446	1343	555	796	1292	457	710	821	317	8751
302	325	863	875	457	1376	569	815	1323	468	727	842	325	8965

30XA UNIT SIZE	MOUNTING WEIGHT (kg) — Cu/Cu†														
	A	B	C	D	E	F	G	H	I	J	K	L	M	N	Total
325	470	470	533	784	445	1333	573	798	1237	454	836	655	470	470	9528
327	481	481	545	801	455	1363	586	816	1265	464	854	669	481	481	9742
350	472	472	535	791	449	1358	578	810	1261	456	838	656	472	472	9621
352	483	483	547	808	459	1388	591	828	1289	466	857	671	483	483	9835

30XA UNIT SIZE	MOUNTING WEIGHT (kg) — Cu/Cu†																
	A	B	C	D	E	F	G	H	I	J	K	L	M	N	O	P	Total
401	798	961	1004	1066	1101	653	359	359	359	359	1017	995	570	570	650	566	11 387
451	334	407	1553	1525	1100	518	573	622	905	1029	474	591	671	712	479	334	11 827
476	500	598	1750	1969	1325	543	582	630	912	1034	484	640	737	786	696	500	13 686
501A	815	1020	1231	1321	1231	644	440	348	348	348	452	998	1113	596	733	507	12 145
501B	408	524	602	408	—	—	—	—	—	—	—	—	—	—	—	—	1 942

†Condenser Coil: Copper Fins/Copper Tubing.

NOTE: Size 501 ships as two modules. The 501A and 501B modules are installed as one chiller.

UNIT MOUNTING WEIGHTS (cont)
UNITS WITHOUT PUMPS AND WITH Cu/Cu CONDENSER COILS

30XA080, 082

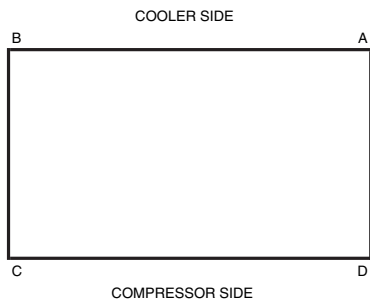

30XA220-302

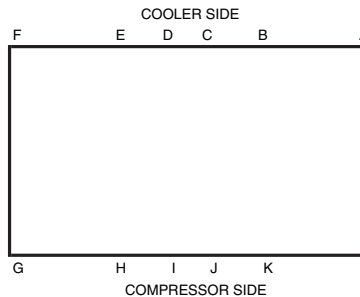

30XA090-122

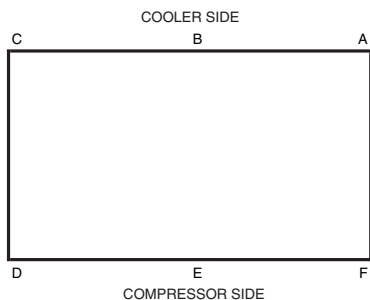

30XA325-352

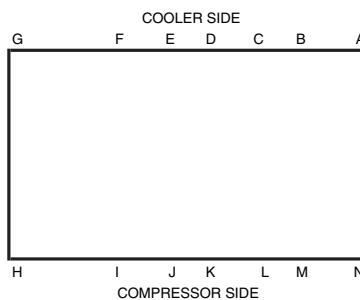

30XA140-162

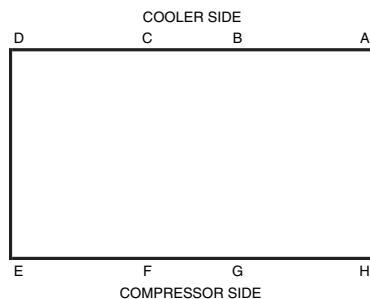

30XA401-501A

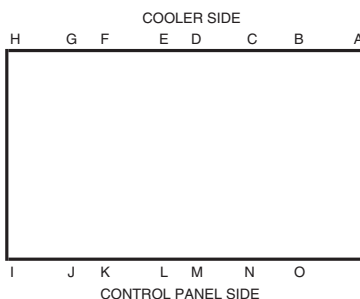

30XA180-202

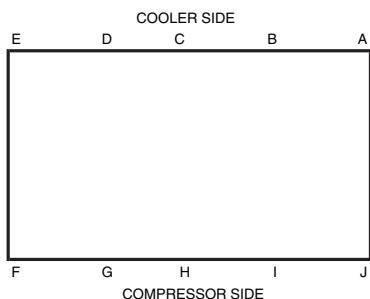

30XA501B

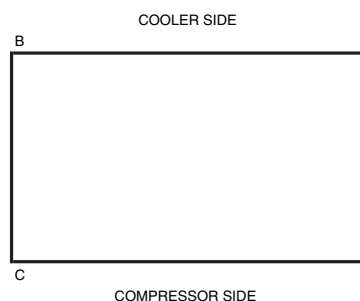

NOTE: Size 501 ships as two modules. The 501A and 501B modules are installed as one chiller.

UNIT MOUNTING WEIGHTS (cont) SINGLE PUMP UNITS WITH Cu/Cu CONDENSER COILS — ENGLISH

30XA UNIT SIZE	MOUNTING WEIGHT (lb) — Cu/Cu†						
	A	B	C	D	E	F	Total
090	1394	3139	1280	1093	2330	1392	10,627
092	1410	3176	1295	1106	2357	1408	10,751
100	1420	3201	1317	1117	2382	1418	10,854
102	1436	3237	1332	1130	2409	1434	10,978
110	1433	3244	1339	1139	2416	1424	10,994
112	1464	3314	1368	1164	2468	1455	11,231
120	1467	3282	1342	1142	2449	1458	11,139
122	1495	3344	1367	1164	2495	1485	11,349

30XA UNIT SIZE	MOUNTING WEIGHT (lb) — Cu/Cu†								
	A	B	C	D	E	F	G	H	Total
140	2188	1735	1804	1800	1273	1004	1876	1990	13,669
142	2261	1793	1864	1860	1316	1038	1939	2056	14,126
160	2242	1762	1821	1831	1299	1019	1896	2043	13,912
162	2311	1816	1877	1887	1339	1050	1954	2106	14,338

SINGLE PUMP UNITS WITH Cu/Cu CONDENSER COILS — SI

30XA UNIT SIZE	MOUNTING WEIGHT (kg) — Cu/Cu†						
	A	B	C	D	E	F	Total
090	632	1424	581	496	1057	631	4820
092	640	1440	587	502	1069	639	4876
100	644	1452	597	507	1080	643	4923
102	651	1468	604	512	1093	651	4979
110	650	1471	607	517	1096	646	4987
112	664	1503	620	528	1120	660	5094
120	665	1489	609	518	1111	661	5053
122	678	1517	620	528	1132	674	5148

30XA UNIT SIZE	MOUNTING WEIGHT (kg) — Cu/Cu†								
	A	B	C	D	E	F	G	H	Total
140	992	787	818	816	577	455	851	903	6200
142	1026	813	846	844	597	471	879	933	6407
160	1017	799	826	830	589	462	860	927	6310
162	1048	824	851	856	607	476	886	955	6504

†Condenser Coil: Copper Fins/Copper Tubing.

30XA090-122

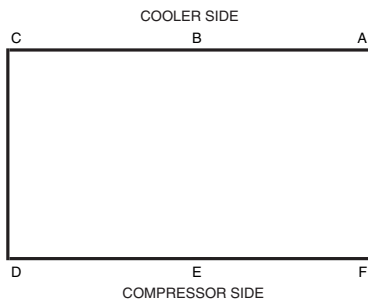

30XA140-162

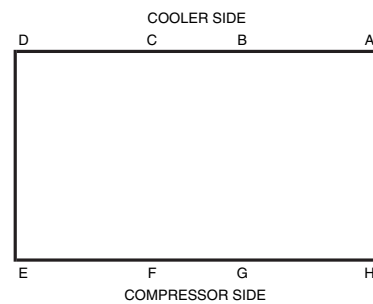

**UNIT MOUNTING WEIGHTS (cont)
DUAL PUMP UNITS WITH Cu/Cu CONDENSER COILS — ENGLISH**

30XA UNIT SIZE	MOUNTING WEIGHT (lb) — Cu/Cu†						
	A	B	C	D	E	F	Total
090	1394	3347	1369	1093	2330	1392	10,924
092	1410	3385	1385	1105	2356	1408	11,048
100	1420	3409	1406	1117	2382	1418	11,151
102	1436	3447	1422	1129	2408	1434	11,275
110	1433	3452	1428	1139	2416	1424	11,291
112	1463	3525	1458	1163	2467	1454	11,528
120	1467	3491	1430	1142	2449	1458	11,436
122	1494	3555	1456	1163	2494	1485	11,646

30XA UNIT SIZE	MOUNTING WEIGHT (lb) — Cu/Cu†								
	A	B	C	D	E	F	G	H	Total
140	2188	1735	2012	1889	1273	1004	1876	1990	13,966
142	2260	1792	2078	1951	1315	1037	1937	2055	14,423
160	2242	1762	2029	1919	1299	1019	1896	2043	14,209
162	2309	1815	2090	1977	1338	1050	1953	2104	14,635

DUAL PUMP UNITS WITH Cu/Cu CONDENSER COILS — SI

30XA UNIT SIZE	MOUNTING WEIGHT (kg) — Cu/Cu†						
	A	B	C	D	E	F	Total
090	632	1518	621	496	1057	631	4955
092	639	1535	628	501	1069	639	5011
100	644	1546	638	507	1080	643	5058
102	651	1563	645	512	1092	650	5114
110	650	1566	648	517	1096	646	5122
112	664	1599	661	527	1119	659	5229
120	665	1583	649	518	1111	661	5187
122	678	1613	661	528	1131	673	5283

30XA UNIT SIZE	MOUNTING WEIGHT (kg) — Cu/Cu†								
	A	B	C	D	E	F	G	H	Total
140	992	787	913	857	577	455	851	903	6335
142	1025	813	942	885	596	470	879	932	6542
160	1017	799	921	871	589	462	860	927	6445
162	1047	823	948	897	607	476	886	954	6638

†Condenser Coil: Copper Fins/Copper Tubing.

30XA090-122

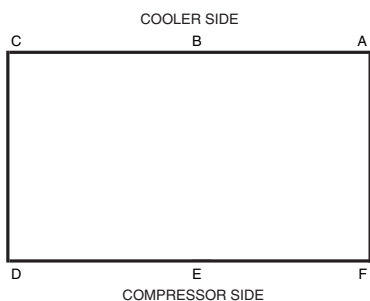

30XA140-162

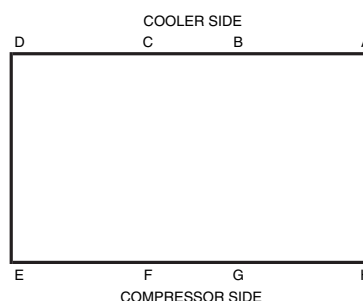

Options and accessories



ITEM	FACTORY-INSTALLED OPTION	FIELD-INSTALLED ACCESSORY
Condenser Coil and Fan Options		
MCHX, E-Coated	X	
Aluminum Fins/Copper Tube	X	
Aluminum Fins/Copper Tube, Pre-Coated	X	
Aluminum Fins/Copper Tube, E-Coated	X	
Copper Fins/Copper Tube, E-Coated	X	
Copper Fins/Copper Tube Condenser Coils	X	
Compressor Sound Reduction Enclosures	X	
High Ambient Temperature Option (140-501 only)	X	
Controls/Communication Options		
BACnet Communication	X	
BACnet/Modbus Translator Control	X	X
Chillervisor System Manager III Multi-Unit Control		X
Energy Management Module (EMM)	X	X
LON Translator Control	X	X
Navigator™ Module	X	X
Remote Enhanced Display		X
Service Option	X	
Remote Service Port		X
Touch Pilot™ Display	X	X
Dual Chiller Accessory Kit		X
Cooler Options		
Minus-One-Pass Cooler	X	
Plus-One-Pass Cooler (not available on 401-501)	X	
Remote Cooler		X
DX (Direct Expansion) Cooler (not available on 401-501)	X	
Electrical Options		
Unit-Mounted Main Disconnect, Non-Fused	X	
Control Transformer	X	
Convenience Outlet		X
High SCCR (Short Circuit Current Rating) (available on 30XA140-352 at 460 or 575 volts only)	X	
Hydronic Pump Package (with or without VFD) (090-162 only) (not available with high SCCR)	X	
Refrigeration Circuit Options		
Wye-Delta Compressor Start	X	
Low Ambient Temperature Head Pressure Control	X	X
Minimum Load Control	X	X
Isolation Valve	X	
Suction Line Insulation	X	
Security/Packaging Option		
Security Grilles	X	X
Upper Hail Guard	X	
Full End Screen	X	
Full Hail Guard		X
Condenser Coil Trim Panels	X	X

LEGEND

- E-Coated** — Epoxy Coating Applied to Entire Coil Assembly
- EMM** — Energy Management Module
- LON** — Local Operating Network
- MCHX** — Microchannel Heat Exchanger

Factory-installed options

Condenser coil options are available to match coil construction to the site conditions for the best durability. Refer to the Condenser Coil Corrosion Protection Options table on page 26 or the appropriate selection guide for more information.

High ambient temperature option provides high-speed condenser fan motors to increase the condenser airflow. This option may allow for an increase in machine capacity, and may also result the selection of a smaller chassis to meet given capacity requirements. The high ambient temperature option is not available on 30XA080-122 units. This option is required for 30XA401-501 units, and is also required for all 30XA401-501 units that are either operating in multi-chiller

NOTES:

1. Std SCCR (short circuit current rating) (5 kA).
2. High SCCR 460-v (65 kA) or 575-v (25 kA).

configurations or have ambient temperatures at or above 100°F (37.8°C).

Minus-one-pass cooler provides a lower pressure drop through the cooler for applications with low delta T (temperature) or high flow or where the coolers are piped in a series arrangement. Applies to flooded coolers only.

Plus-one-pass cooler provides a greater efficiency for brine applications and in applications with a high delta T and low flow. Applies to flooded coolers only. This option is not available on unit sizes 401-501.

Wye-delta start is an alternate starting method which reduces the in-rush current when starting the compressor.

Energy management module provides energy management capabilities to minimize chiller energy consumption. Several features are provided with this module including leaving fluid temperature reset, cooling set point or demand limit control from a 4 to 20 mA signal, space temperature reset (requires field-installed space temperature sensor), 2-step demand limit control (from 0 to 100%) activated by a remote contact closure, and discrete input for “Ice Done” indication for ice storage system interface.

Service option provides a remote service port for Navigator™ display connection (sizes 080-122, not required on other sizes) and a factory-installed convenience outlet that includes 4-amp GFI (ground fault interrupt) receptacle. Convenience outlet is 115-v female receptacle. Service option not available with 380-v units. While the service option is not available as a field-installed accessory, the remote service port and convenience outlet are available individually as field-installed accessories.

Direct expansion (DX) cooler option provides a shell and tube, direct expansion cooler as an alternative to the standard flooded cooler. The DX cooler is especially beneficial in low temperature applications and/or applications employing high glycol concentrations. This option is not available on sizes 401-501.

Low ambient temperature head pressure control permits operation of the 30XA units to -20°F (-29°C) outdoor ambient temperature. The control is also available as a field-installed accessory and requires field-installed wind baffles.

Minimum load control allows additional capacity reduction for unit operation below the minimum step of unloading via hot gas bypass. Minimum load control is also available as a field-installed accessory.

Isolation valve provides a means of isolating the compressors from the cooler vessel, which is beneficial in servicing the chiller. The isolation option comes in various configurations depending on the cooler type (flooded or DX cooler) and the installation region (Middle Eastern or elsewhere). On all units equipped with the flooded cooler which are not installed in the Middle East region, liquid line service valves and motorized discharge service valves are always provided per refrigerant circuit. For Middle Eastern regions only, in addition to the liquid line service valves, manual discharge valves are standard and motorized discharge service valves are optional. On units equipped with the optional DX cooler, the liquid line service valves and manual discharge service valves are included in the isolation valve option, regardless of the region of installation. Regardless of which cooler option is employed, the selection of the isolation valve option results in chillers which are equipped with a liquid line service valve, a discharge service valve (motorized or manual type), and a series of valves on or near the cooler. The net effect is to provide isolation capability in the condenser area, the cooler area and the compressor area.

Unit-mounted non-fused disconnect option provides non-fused disconnect for unit power located at the unit. This option is not available with the combination of dual point power and high SCCR.

Suction line insulation is tubular closed-cell insulation. This option is required on applications with leaving fluid temperatures below 30°F (-1.1°C) and recommended for areas of high dewpoints where condensation may be a concern.

BACnet communication option provides pre-programmed factory-installed communication capability with a BACnet MS/TP network and allows integration with i-Vu® Open control system or a third-party BACnet building automation system. No field programming is required.

BACnet/Modbus¹ translator control provides an interface between the chiller and a BACnet Local Area Network (LAN, i.e., MS/TP EIA-485). The BACnet/Modbus translator control is also available as a field-installed accessory. Field programming is required.

LON translator control provides an interface between the chiller and a Local Operating Network (LON, i.e., LonWorks² FT-10A ANSI/EIA-709.1). The LON translator control is also available as a field-installed accessory. Field programming is required.

Condenser coil trim panels provide an aesthetic, finished appearance for the condenser coil ends of the compressor side of the unit. Condenser coil trim panels are also available as a field-installed accessory.

Control transformer is sized to supply the needs of the control circuit from the main power supply.

High SCCR (short circuit current rating) devices allow the chiller to tolerate a 65 kA (460-v units) or 25 kA (575-v units) short circuit current for a brief period of time while protecting downstream components. The high SCCR provides a higher level of protection than the standard chiller components. This option is only available on 30XA140-352 units and only at 460 or 575 volts. The standard SCCR rating, regardless of voltage or chiller size, is 5 kA.

Hydronic pump package adds circulating pumps, a combination valve (isolation, modulation and check), strainer, Victaulic piping connections, insulation and heaters and pressure temperature taps (3). The pumps are available in single or dual (lead/lag controlled), cooler pump versions with total dynamic head external to the chiller from approximately 20 to 140 ft (6.1 to 42.7 m). This package is available with or without a VFD. The hydronic pump package is only available for unit sizes 30XA090-162, and not available in combination with the high SCCR option.

Security grilles are coated grilles that protect the condenser, cooler and compressors. These are also available as an accessory.

Upper hail guard consists of louvered panels on the ends of the machine, which firmly fasten to the machine frame and provide coverage from the top of the unit to the bottom of the coil. A hinged accessory hail guard is also available. The accessory covers the entire unit end (both ends), and, with its hinged design, is not identical to this option.

Full end screen consists of louvered panels on the ends of the machine, providing complete coverage from the top

1. Modbus is a registered trademark of Schneider Electric.
2. LonWorks is a registered trademark of Echelon Corporation.

Options and accessories (cont)



to the bottom of the unit. This option functions as both a privacy screen and a hail guard. For hail protection, an accessory hail guard is also available. The accessory covers the entire unit end (both ends), and, with its hinged design, is not identical to this option.

Compressor enclosures provide sound reduction for the screw compressors.

Navigator™ module provides a portable, hand-held display for convenient access to unit status, operation, configuration and troubleshooting diagnostics capability.

Touch Pilot™ display provides a touch screen user interface. This fixed screen display can be used to commission, monitor and control Carrier Comfort Network® devices. It provides access to configuration, maintenance, service, set point, time schedule, alarm history and status data.

Field-installed accessories

Touch Pilot display used as an accessory is a cost-effective, touch-screen, remote mount device that can be used in lieu of the remote enhanced display.

Remote enhanced display is a remotely mounted indoor 40-character per line, 16-line display panel for unit monitoring and diagnostics.

Remote cooler kit allows for remote installation of the cooler. Never bury refrigerant lines when using this accessory or in any other application. This accessory is not available on sizes 401-501.

Chillervisor System Manager III multi-unit control allows sequencing of two chillers in series, or between two and eight chillers in parallel.

Low ambient temperature head pressure control permits operation of the 30XA units to -20°F (-29°C) outdoor ambient temperature. The control is also available as a factory-installed option and requires field-installed wind baffles.

Energy management module provides energy management capabilities to minimize chiller energy consumption. Several features are provided with this module including leaving fluid temperature reset, cooling set point, space temperature reset (requires field-installed space temperature sensor) or demand limit control from a 4 to 20 mA signal, 2-step demand limit control (from 0 to 100%) activated by a remote contact closure (one-step demand limit does not require the energy management module), and

discrete input for “Ice Done” indication for ice storage system interface.

Remote service port consists of a receptacle for Navigator device connection. The port is housed in a waterproof enclosure conveniently located for easy access to information during operation and maintenance routines.

Navigator™ module is required when there is a need for a portable hand-held display, and the main display is a Touch Pilot™ display.

Convenience outlet includes 4-amp GFI (ground fault interrupt) receptacle. Convenience outlet is 115-v female receptacle. Not available with 380-v units.

BACnet/Modbus translator control provides an interface between the chiller and a BACnet Local Area Network (LAN, i.e., MS/TP EIA-485). The BACnet/Modbus translator control is also available as a factory-installed option. Field programming is required.

LON translator control provides an interface between the chiller and a Local Operating Network (LON, i.e., LonWorks FT-10A ANSI/EIA-709.1). The LON translator control is also available as a factory-installed option. Field programming is required.

Condenser coil trim panels provide an aesthetic, finished appearance for the condenser coil ends of the compressor side of the unit. Condenser coil trim panels are also available as a factory-installed option.

Full hail guard consists of hinged, louvered panels, which cover both ends of the unit. This accessory provides complete protection from hail and flying debris. For hail protection, two factory options are also available. These options directly fasten to the end of the chillers (are not hinged), and therefore are not identical to this accessory.

Minimum load control allows additional capacity reduction for unit operation below the minimum step of unloading via hot gas bypass. Minimum load control is also available as a factory-installed option.

Security grilles are coated grilles that protect the condenser, cooler, and compressors. These are also available as a factory-installed option.

Dual chiller accessory kit provides the additional hardware (thermistors, wells, connectors) required for applications with 2 chillers running in parallel.

CONDENSER COIL CORROSION PROTECTION OPTIONS

ENVIRO-SHIELD™ OPTION*	ENVIRONMENT				
	Standard	Mild Coastal	Severe Coastal	Industrial	Combined Industrial/Coastal
Novation® Heat Exchanger (Standard)	See NACO Packaged Chiller Builder				
Novation Heat Exchanger, E-coat	See NACO Packaged Chiller Builder				
AL Fins	X				
CU Fins		X			
AL Fins, E-Coat			X	X	X
CU Fins, E-Coat			X		
AL Fins, Pre-Coated		X			

LEGEND

- AL — Aluminum
- CU — Copper
- NACO — North American Commercial Operations

* See NACO Packaged Chiller Builder for details. Additional corrosion protection is available. For Novation or Round Tube/Plate Fin (RTPF) heat exchangers, see selection guide “Environmental Corrosion Protection” (Publication 04-581061-01).

30XA080 (SEE NOTE 4)

NOTES:

1. Unit must have clearances as follows:
Top — Do not restrict
Sides and Ends — 6 ft (1.8 m) from solid surface.
2. Temperature relief devices are located on liquid line and economizer assemblies and have 1/4-in. flare connection.
3. 3/8-in. NPT vents and drains located in each cooler head at each end of cooler.
4. Drawing depicts unit with single point power and standard two-pass cooler. Refer to the Packaged Chiller Builder program for other configurations.
5. Dimensions are shown in inches. Dimensions in [] are in millimeters.

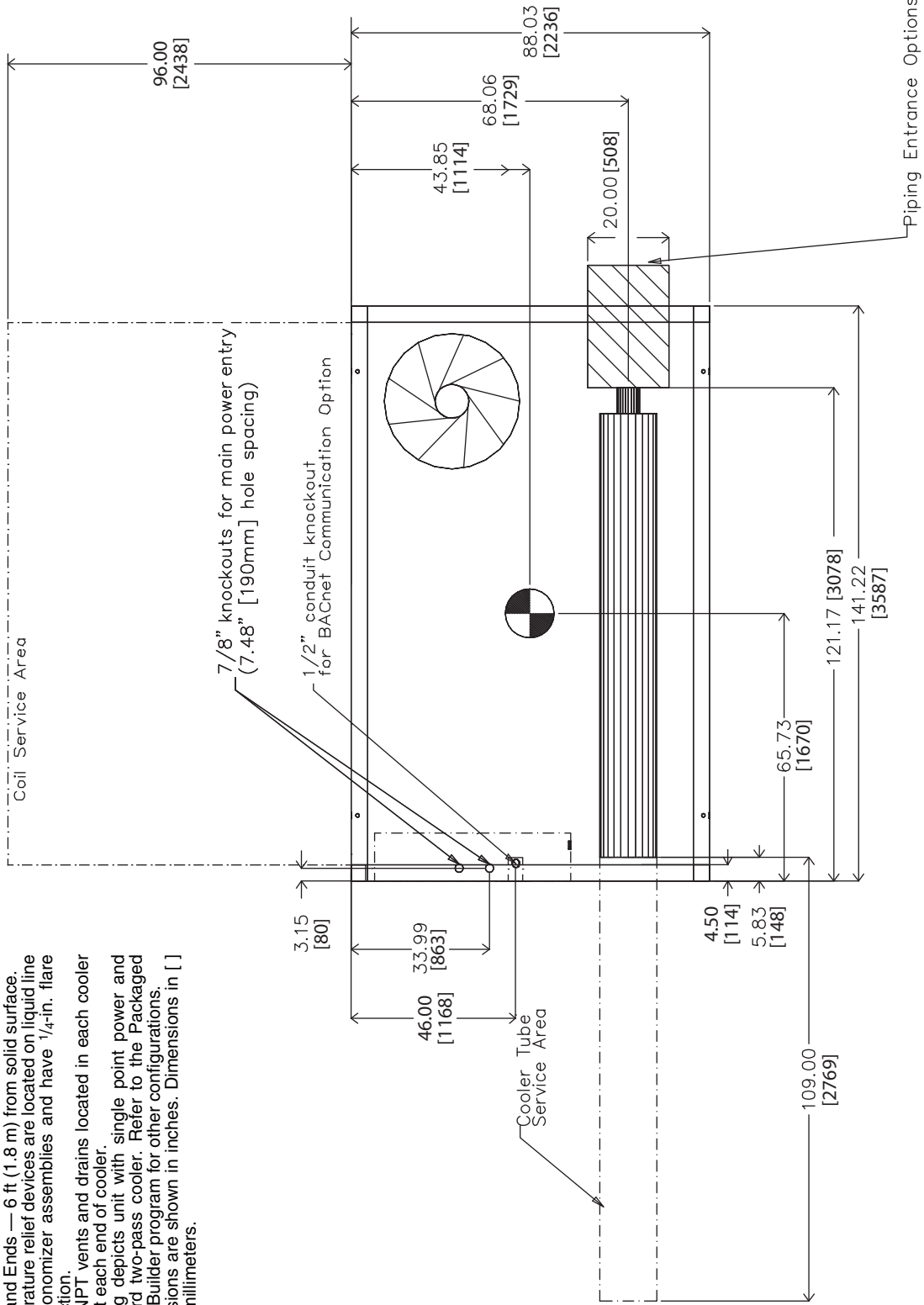

TOP VIEW

30XA080 (cont)

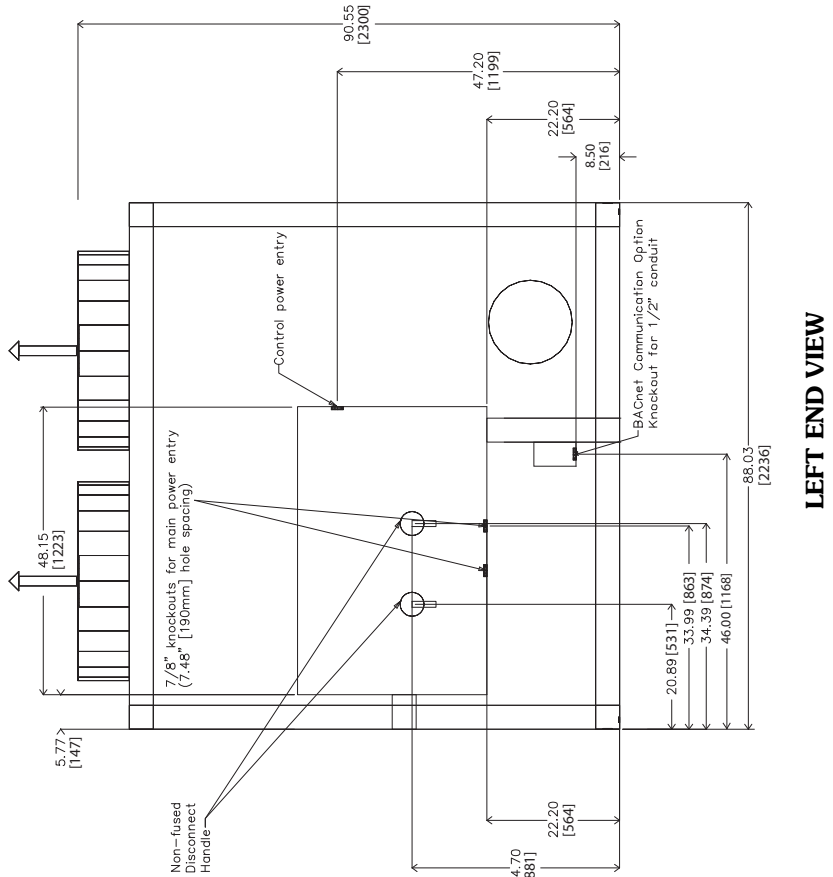
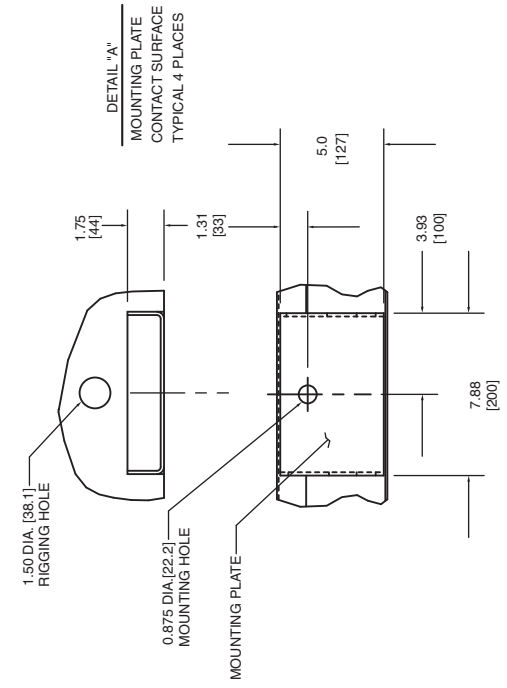
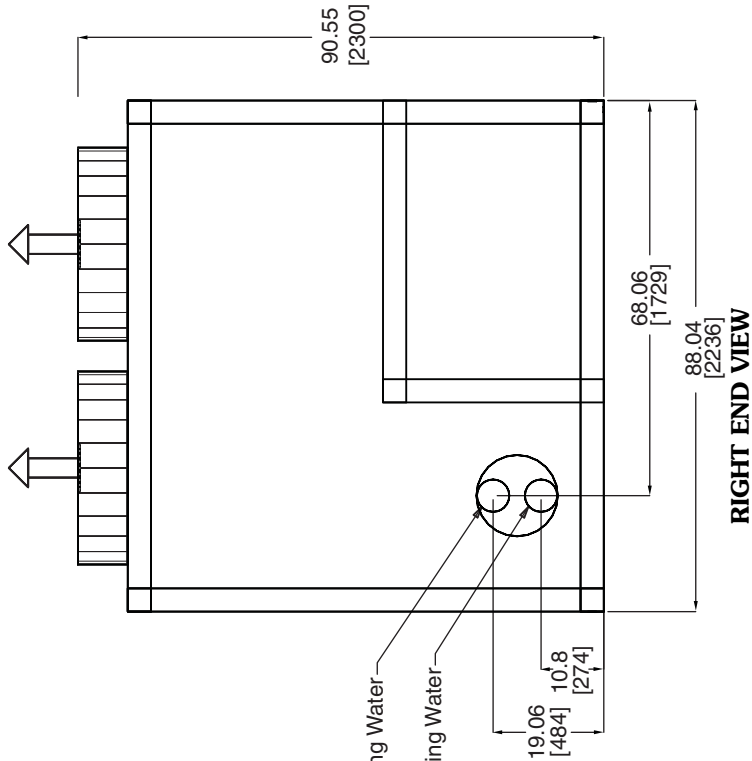

30XA080 (cont)

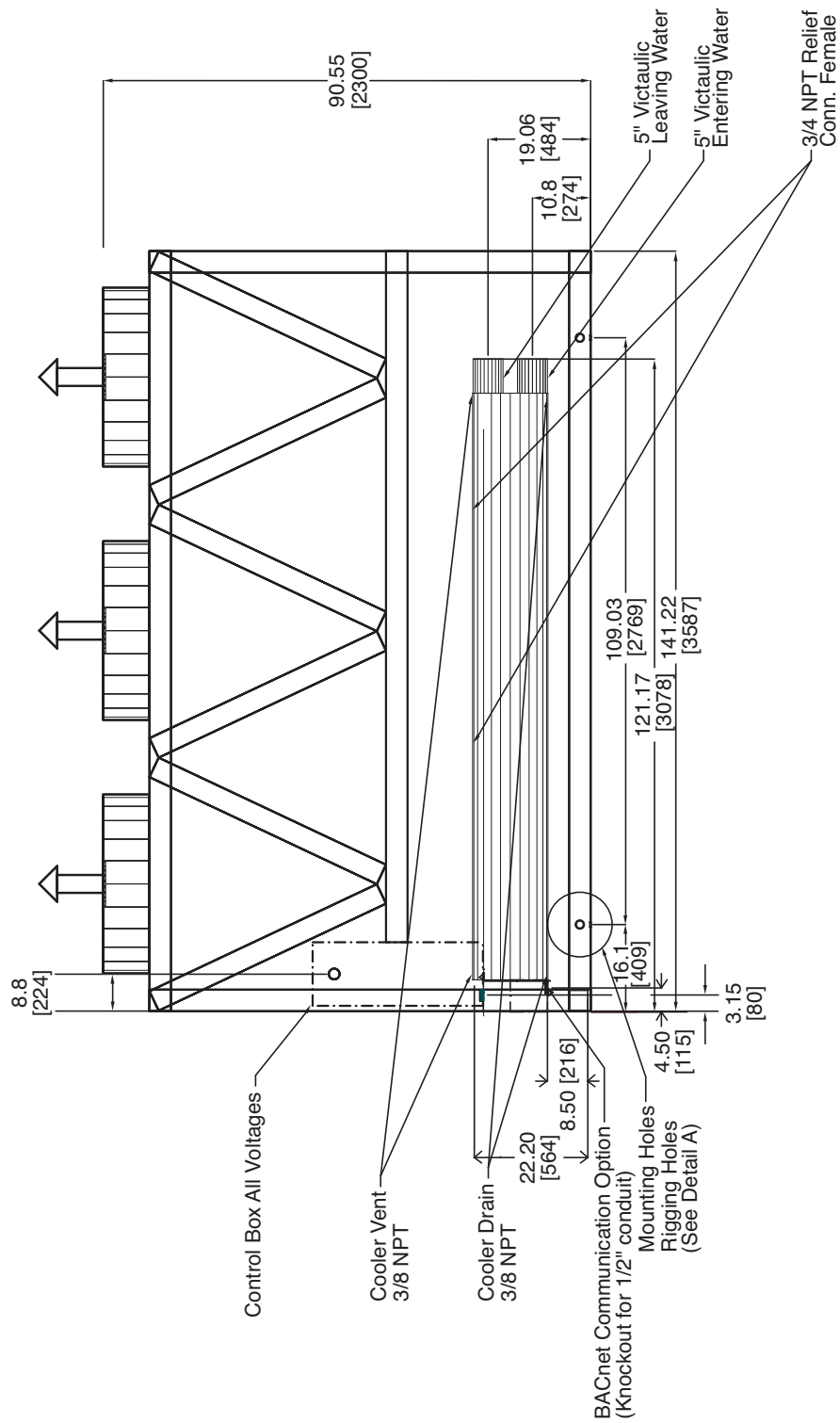

FRONT VIEW

30XA082 (DX COOLER)

NOTES:

- Unit must have clearances as follows:
 Top — Do not restrict
 Sides and Ends — 6 ft (1.8 m) from solid surface
 Airflow Side — 8 ft (2.4 m) required for coil service area.
- Temperature relief devices are located on liquid line and economizer assemblies and have 1/4-in. flare connection.
- Pressure relief devices are located on the cooler (5/8-in. NPT male connector) and on each oil separator (3/8-in. flare connector).
- Dimensions are shown in inches. Dimensions in [] are in millimeters.

30XA UNIT	CGx	CGy
082	68.5 [1739.9]	35.3 [896.6]

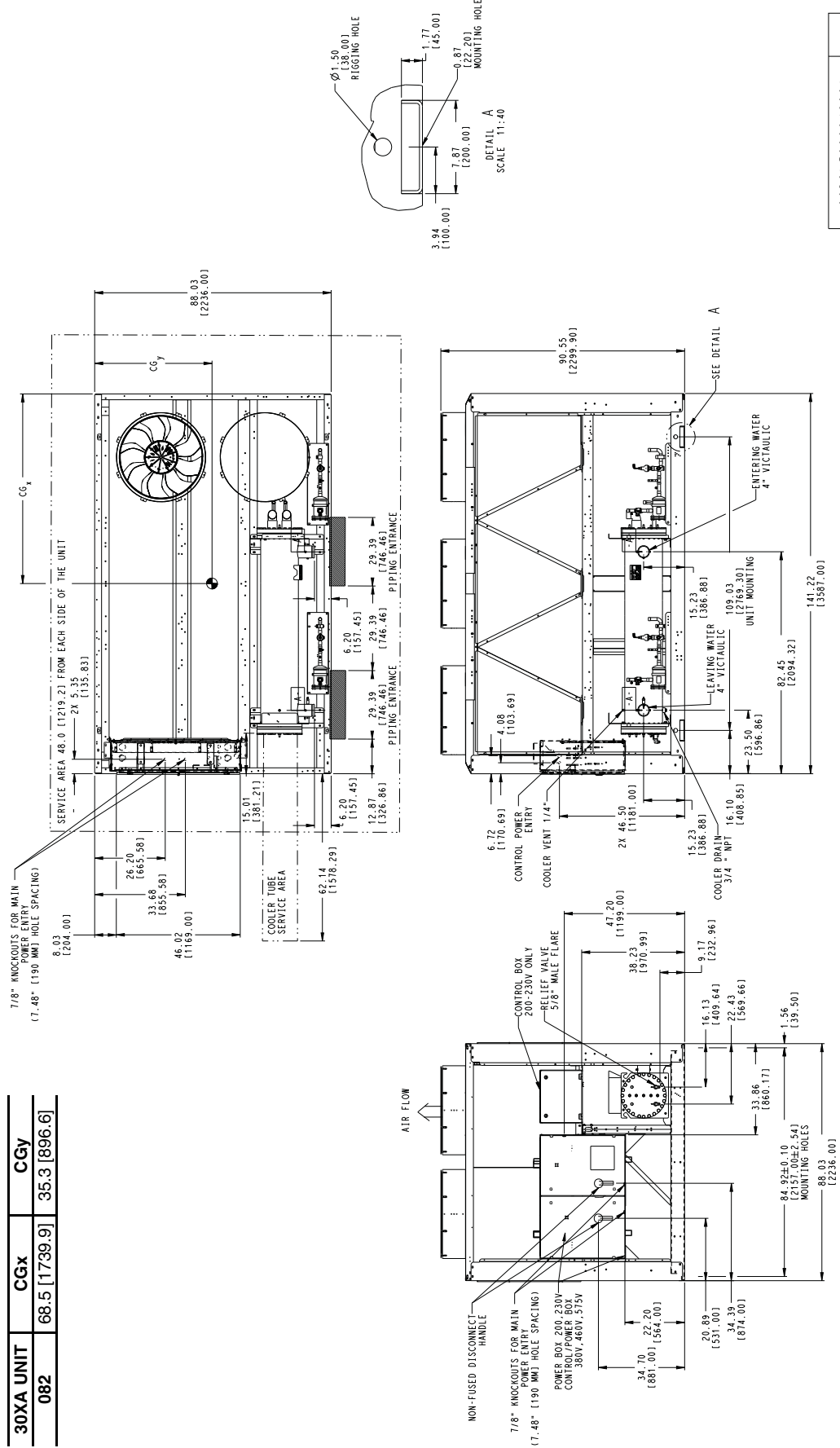

00DCN50004300A E

30XA090,100,110,120 WITHOUT PUMP (SEE NOTE 4)

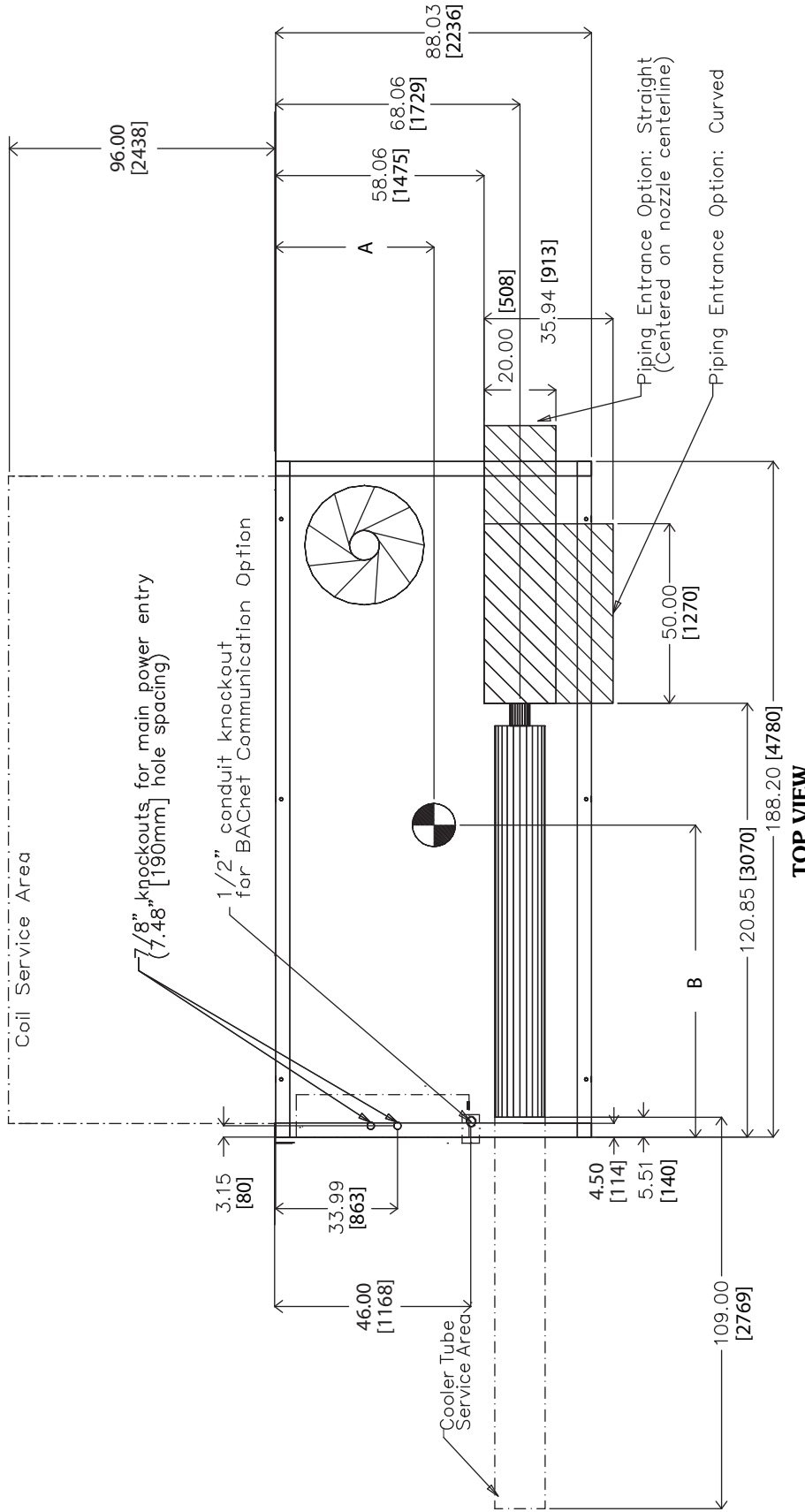

- NOTES:**
- Unit must have clearances as follows:
Top — Do not restrict
Sides and Ends — 6 ft (1.8 m) from solid surface.
 - Temperature relief devices are located on liquid line and economizer assemblies and have 1/4-in. flare connection.
 - 3/8-in. NPT vents and drains located in each cooler head at each end of cooler.
 - Drawing depicts unit with single-point power and standard two-pass cooler. Refer to the Packaged Chiller Builder program for other configurations.
 - Dimensions are shown in inches. Dimensions in [] are in millimeters.

30XA UNIT	A	B
090	44.11 [1120]	86.93 [2208]
100	44.11 [1120]	87.22 [2215]
110	44.11 [1120]	87.62 [2226]
120	44.11 [1120]	87.12 [2213]

30XA090,100,110,120 WITHOUT PUMP (cont)

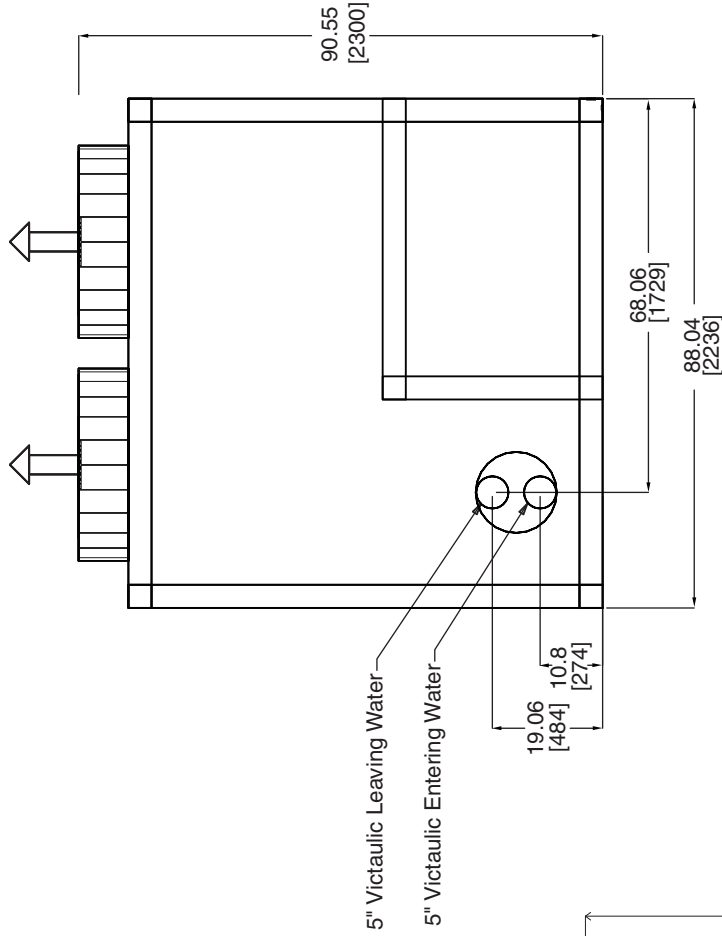

RIGHT END VIEW

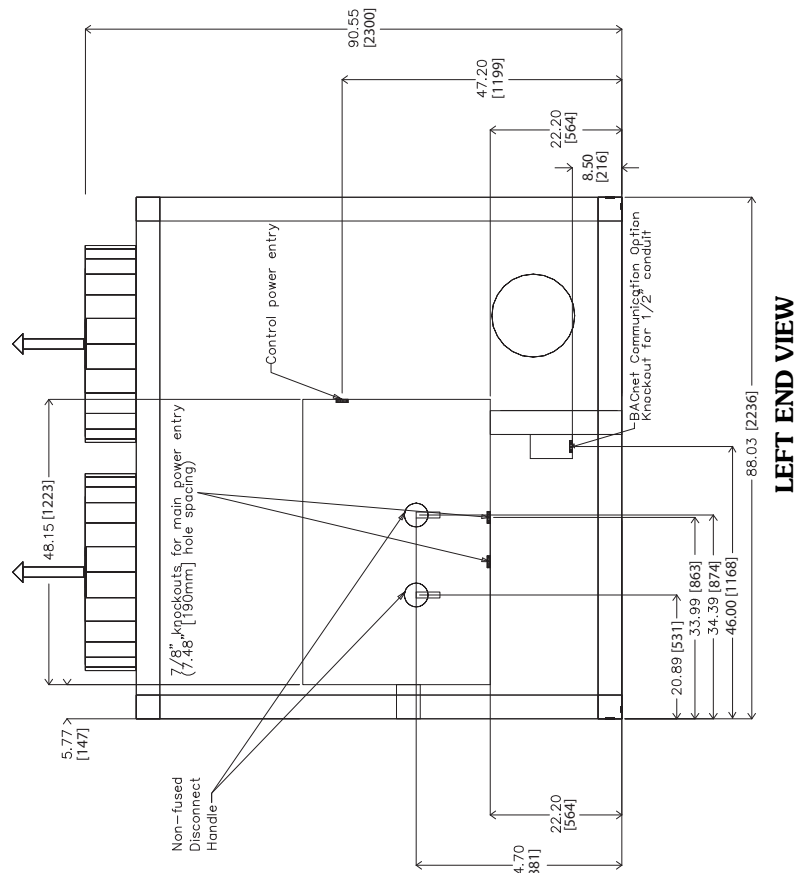
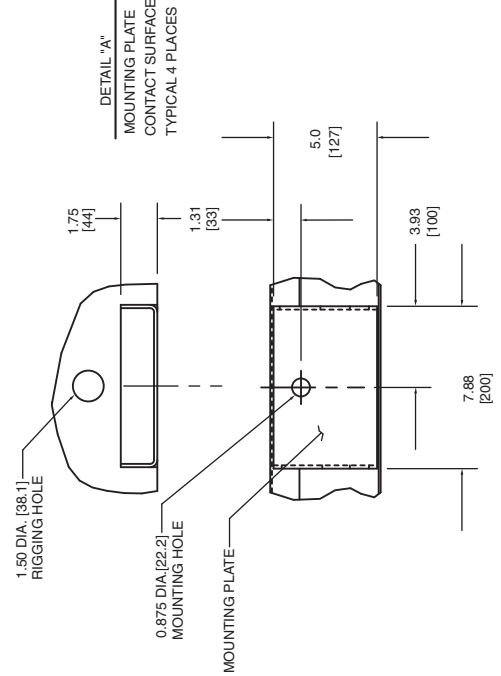

LEFT END VIEW

30XA090,100,110,120 WITHOUT PUMP (cont)

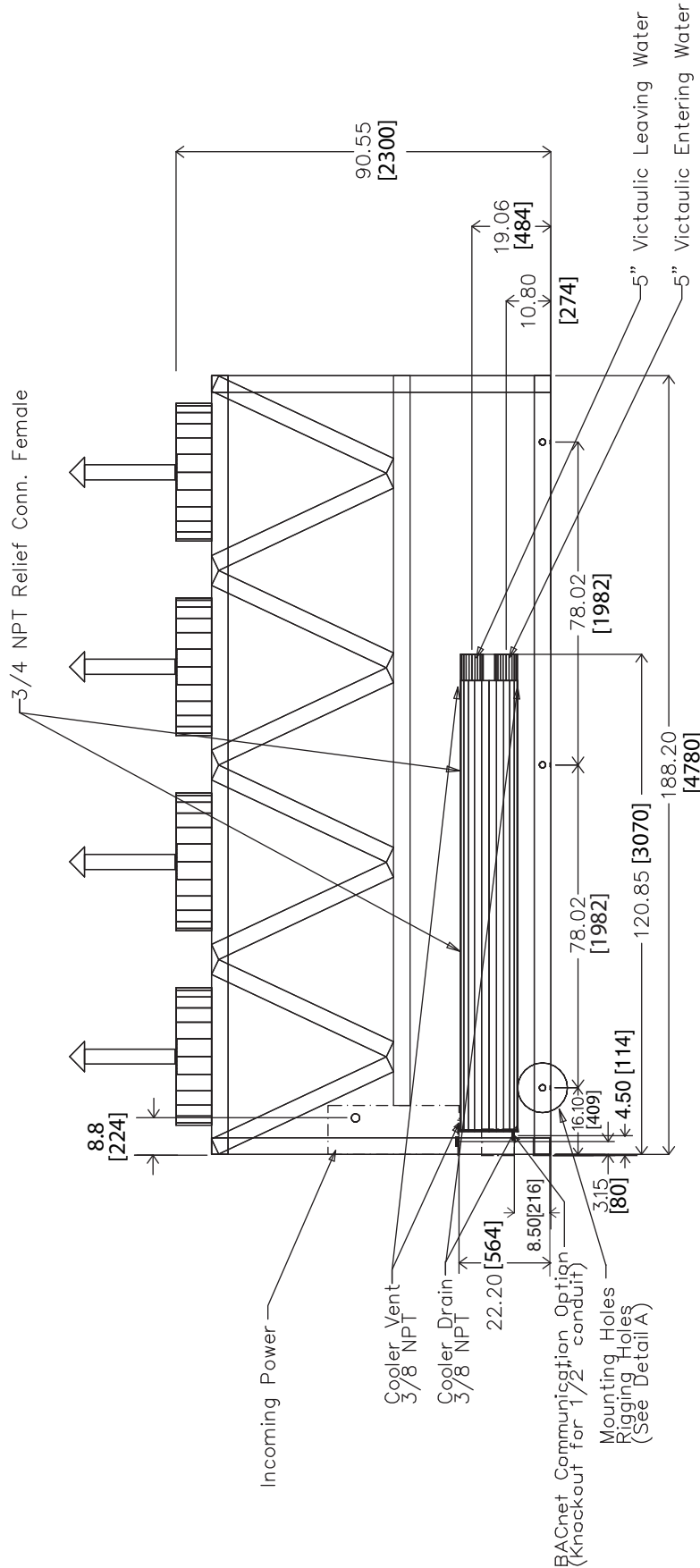

FRONT VIEW

30XA090, 100, 110, 120 WITH PUMP (SEE NOTE 4)

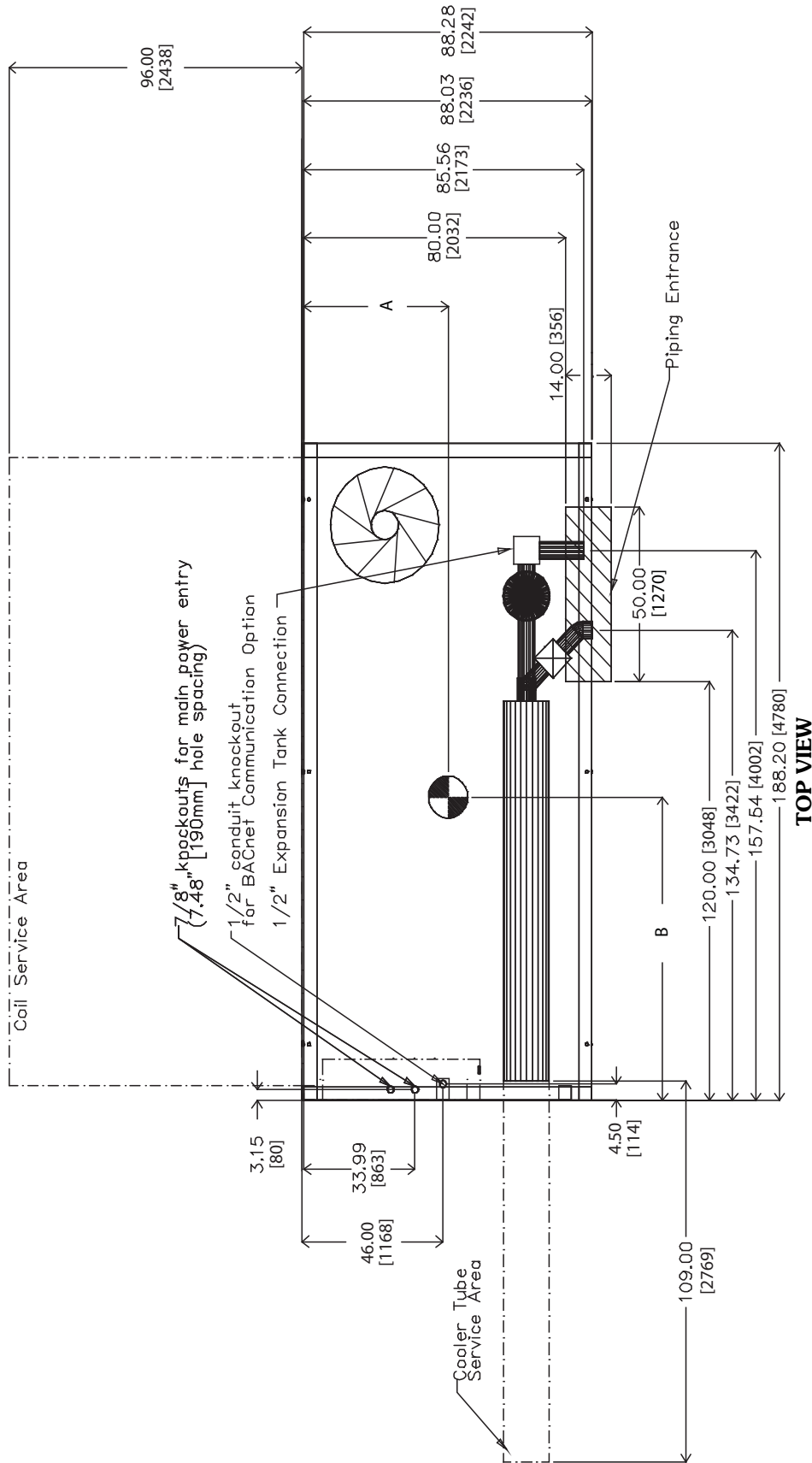

NOTES:

- Unit must have clearances as follows:
 - Top — Do not restrict
 - Sides and Ends — 6 ft (1.8 m) from solid surface.
- Temperature relief devices are located on liquid line and economizer assemblies and have 1/4-in. flare connection.
- 3/8-in. NPT vents and drains located in each cooler head at each end of cooler.
- Drawing depicts unit with single-point power and standard two-pass cooler. Refer to the Packaged Chiller Builder program for other configurations.
- Dimensions are shown in inches. Dimensions in [] are in millimeters.

30XA UNIT	A	B
090	44.11 [1120]	86.93 [2208]
100	44.11 [1120]	87.22 [2215]
110	44.11 [1120]	87.62 [2226]
120	44.11 [1120]	87.12 [2213]

30XA090, 100, 110, 120 WITH PUMP (cont)

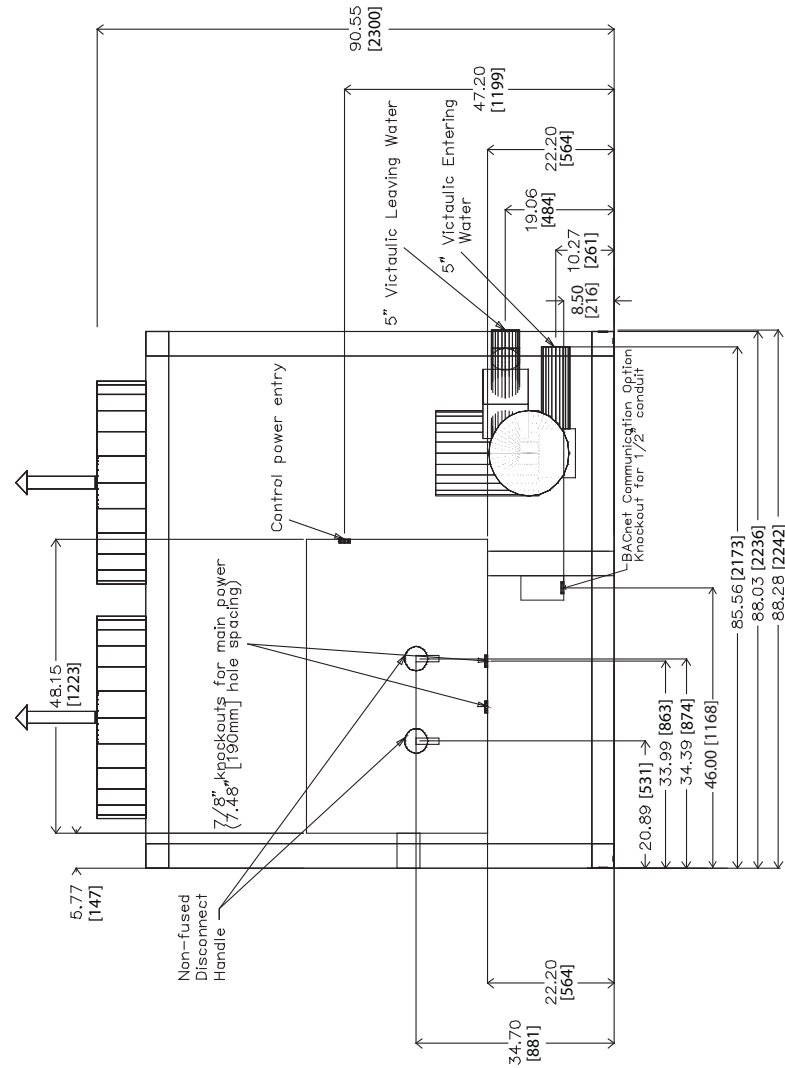
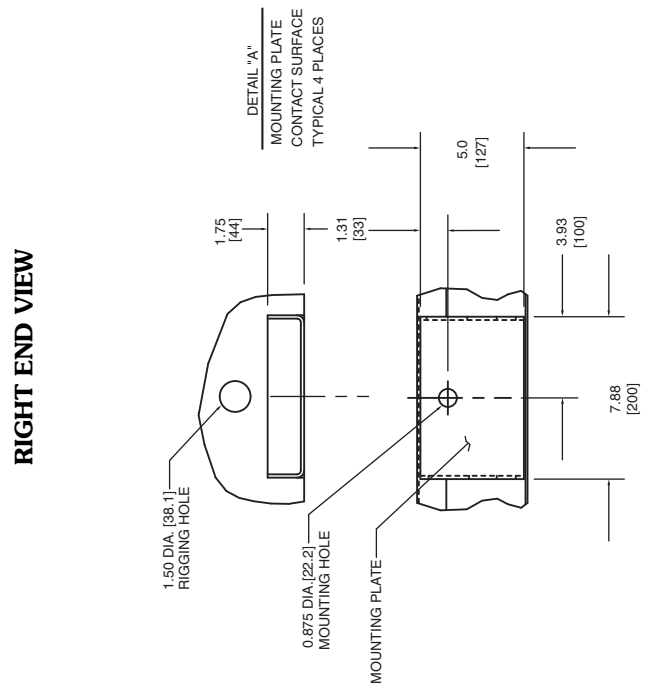
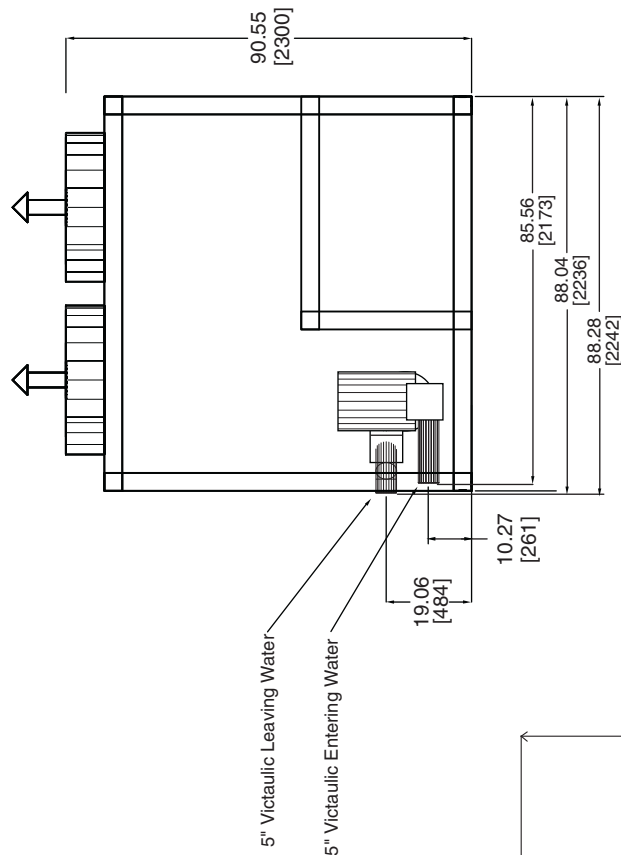

30XA090, 100, 110, 120 WITH PUMP (cont)

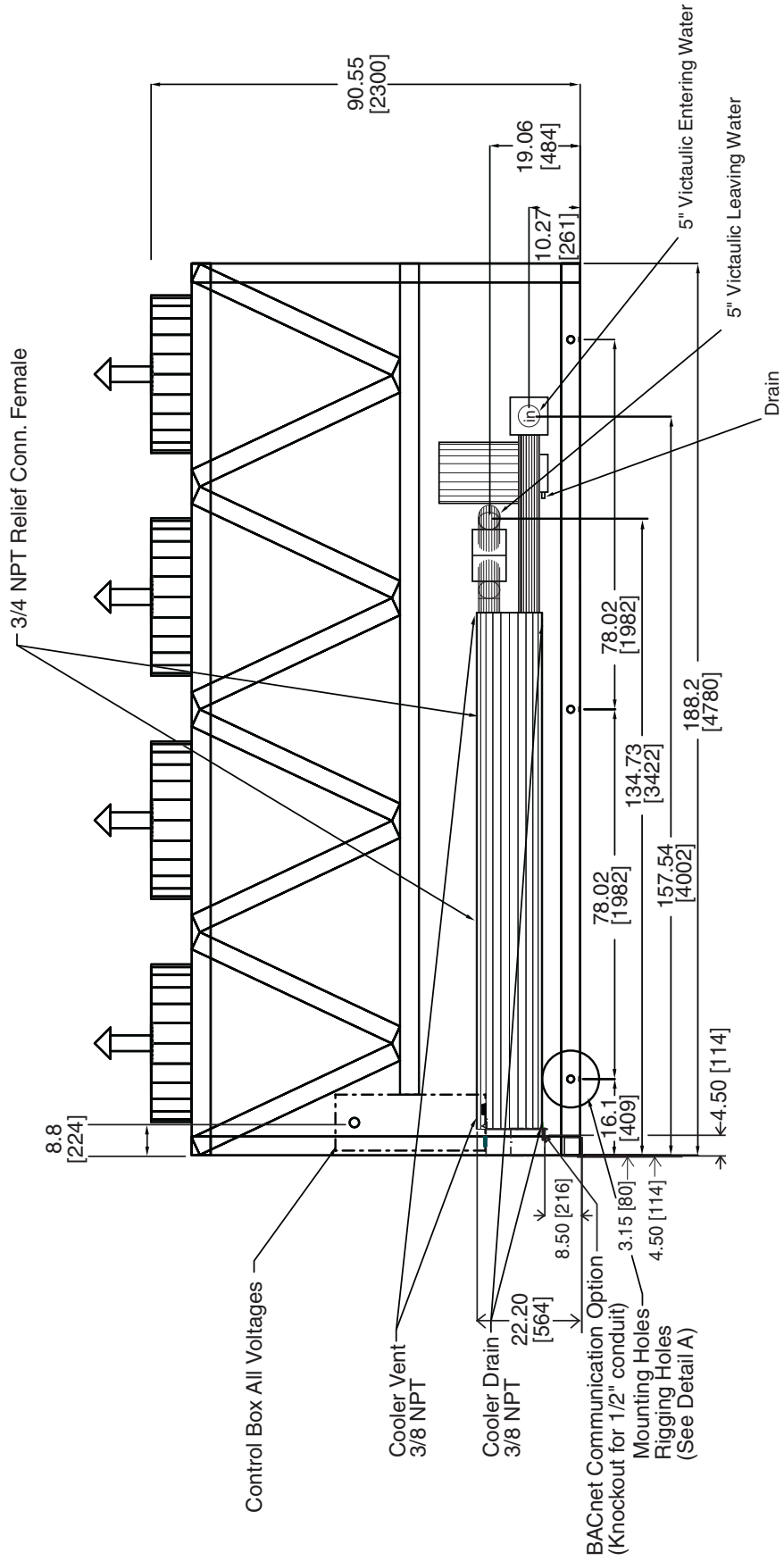

FRONT VIEW

30XA092,102 (DX COOLER)

NOTES:

- Unit must have clearances as follows:
Top — Do not restrict
Sides and Ends — 6 ft (1.8 m) from solid surface
Airflow Side — 8 ft (2.4 m) required for coil service area.
- All pumps have drains located at the bottom of volute for draining.
- Temperature relief devices are located on liquid lines and economizer assemblies and have 1/4-in. flare connection.
- No pump package leaving water connection is same size and has same Y and Z dimensions as entering water. Also has same PDx dimension as pump package.
- Leaving water throttling valve and support is factory supplied with pump package, but must be field installed.
- Dimensions for entering water without hydronic kit are as shown in the drawing.
- Pressure relief devices are located on the cooler (3/8-in. NPT male connector) and on each oil separator (3/8-in. flare connector).
- Dimensions are shown in inches. Dimensions in [] are in millimeters.

30XA UNIT	CENTER OF GRAVITY		PUMP SUCTION (PS)			PUMP DISCHARGE (PD)		
	CGx	CGy	X ± 0.25	Y ± 0.25	Z ± 0.25	X ± 0.25	Y ± 0.25	Z ± 0.25
092	102.5 [2603.51]	35.5 [901.7]	32.40 [822.98]	10.79 [274.01]	11.45 [290.72]	13.32 [338.33]	15.23 [386.89]	7.8 [198.15]
102	102.2 [2595.91]	35.5 [901.7]	32.40 [822.98]	10.79 [274.01]	11.45 [290.72]	13.32 [338.33]	15.23 [386.89]	7.8 [198.15]

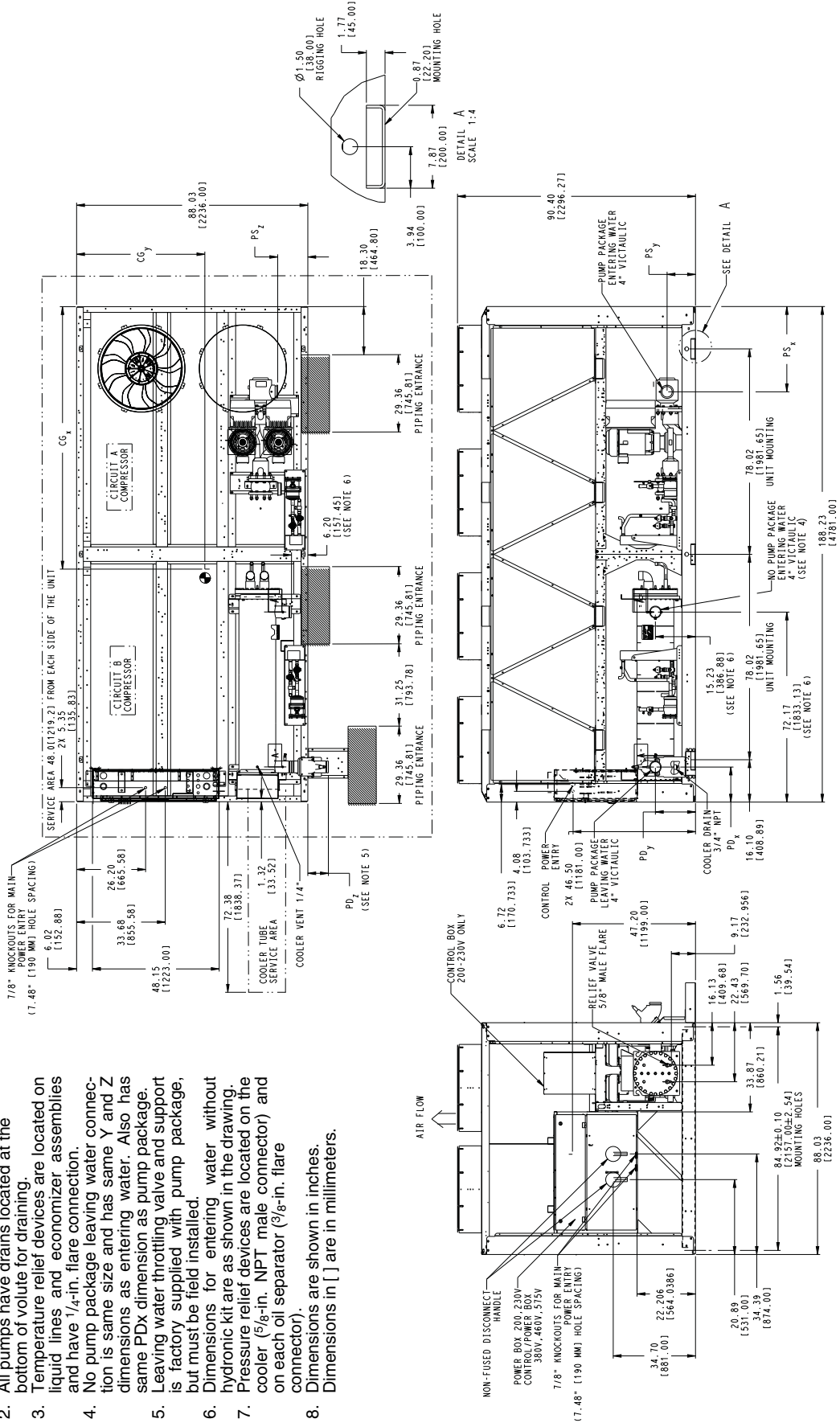

00DCN500004400A E

30XA112,122 (DX COOLER)

NOTES:

- Unit must have clearances as follows:
 Top — Do not restrict
 Sides and Ends — 6 ft (1.8 m) from solid surface
 Airflow Side — 8 ft (2.4 m) required for coil service area.
 All pumps have drains located at the bottom of volute for draining.
- Temperature relief devices are located on liquid lines and economizer assemblies and have 1/4-in. flare connection, and has same Y and Z dimensions as entering water.
- Also has same PDx dimension as pump package.
- Leaving water throttling valve and support is factory supplied with pump package, but must be field installed.
- Dimensions for entering water without hydronic kit are as shown in the drawing.
- Pressure relief devices are located on the cooler (5/8-in. NPT male connector) and on each oil separator (3/8-in. flare connector.)
- Dimensions are shown in inches. Dimensions in [] are in millimeters.

30XA UNIT	CENTER OF GRAVITY			PUMP SUCTION (PS)			PUMP DISCHARGE (PD)		
	CGx	CGy	CGz	X ± 0.25	Y ± 0.25	Z ± 0.25	X ± 0.25	Y ± 0.25	Z ± 0.25
112	101.8 [2585.7]	35.5 [901.7]	11.72 [297.69]	10.79 [274.01]	10.71 [272.03]	13.29 [337.57]	15.23 [386.89]	14.27 [362.46]	14.27 [362.46]
122	102.2 [2595.9]	35.5 [901.7]	11.72 [297.69]	10.79 [274.01]	10.71 [272.03]	13.29 [337.57]	15.23 [386.89]	14.27 [362.46]	14.27 [362.46]

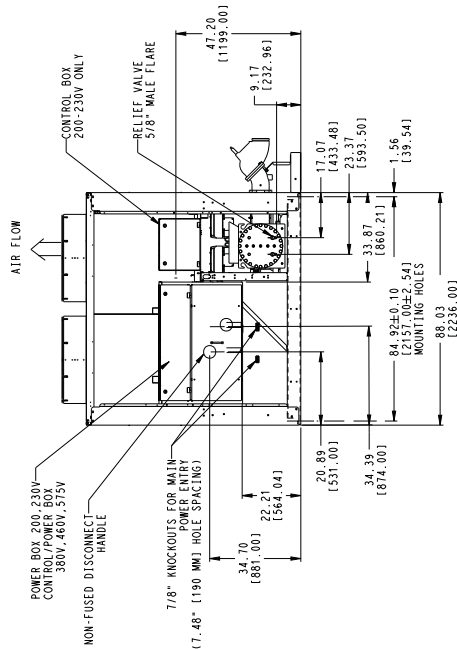
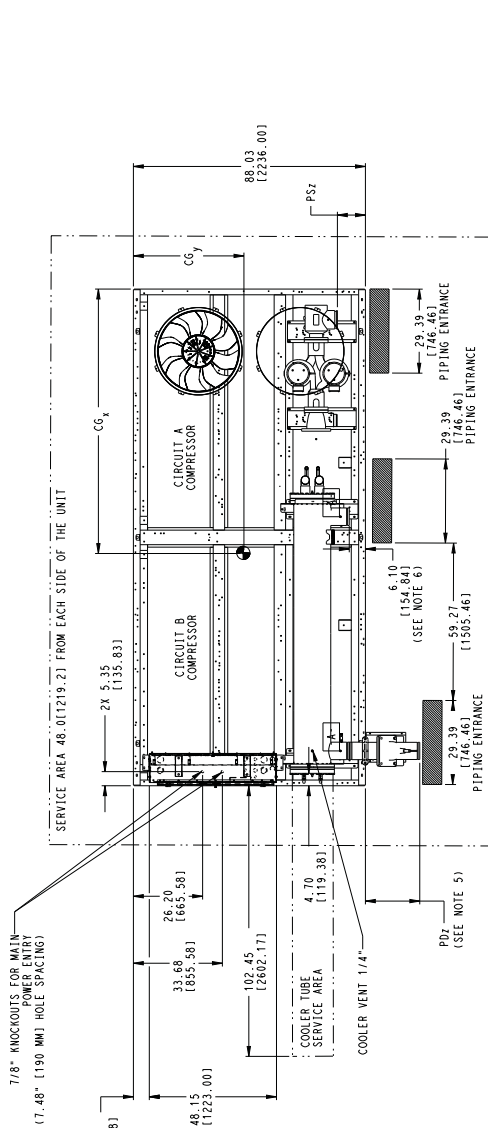

00DCN500004500A

E

30XA140,160 WITHOUT PUMP (SEE NOTE 4)

NOTES:

- Unit must have clearances as follows:
Top — Do not restrict
Sides and Ends — 6 ft (1.8 m) from solid surface.
- Temperature relief devices are located on liquid line and economizer assemblies and have 1/4-in. flare connection.
- 3/8-in. NPT vents and drains located in each cooler head at each end of cooler.
- Drawing depicts unit with single-point power, standard two-pass cooler, standard SCCR (short circuit current rating), and nominal voltage range of 380 to 575 v. Refer to the Packaged Chiller Builder program for other configurations.
- Dimensions are shown in inches. Dimensions in [] are in millimeters.

30XA UNIT	A	B
140	44.63 [1134]	115.88 [2943]
160	44.61 [1133]	115.64 [2937]

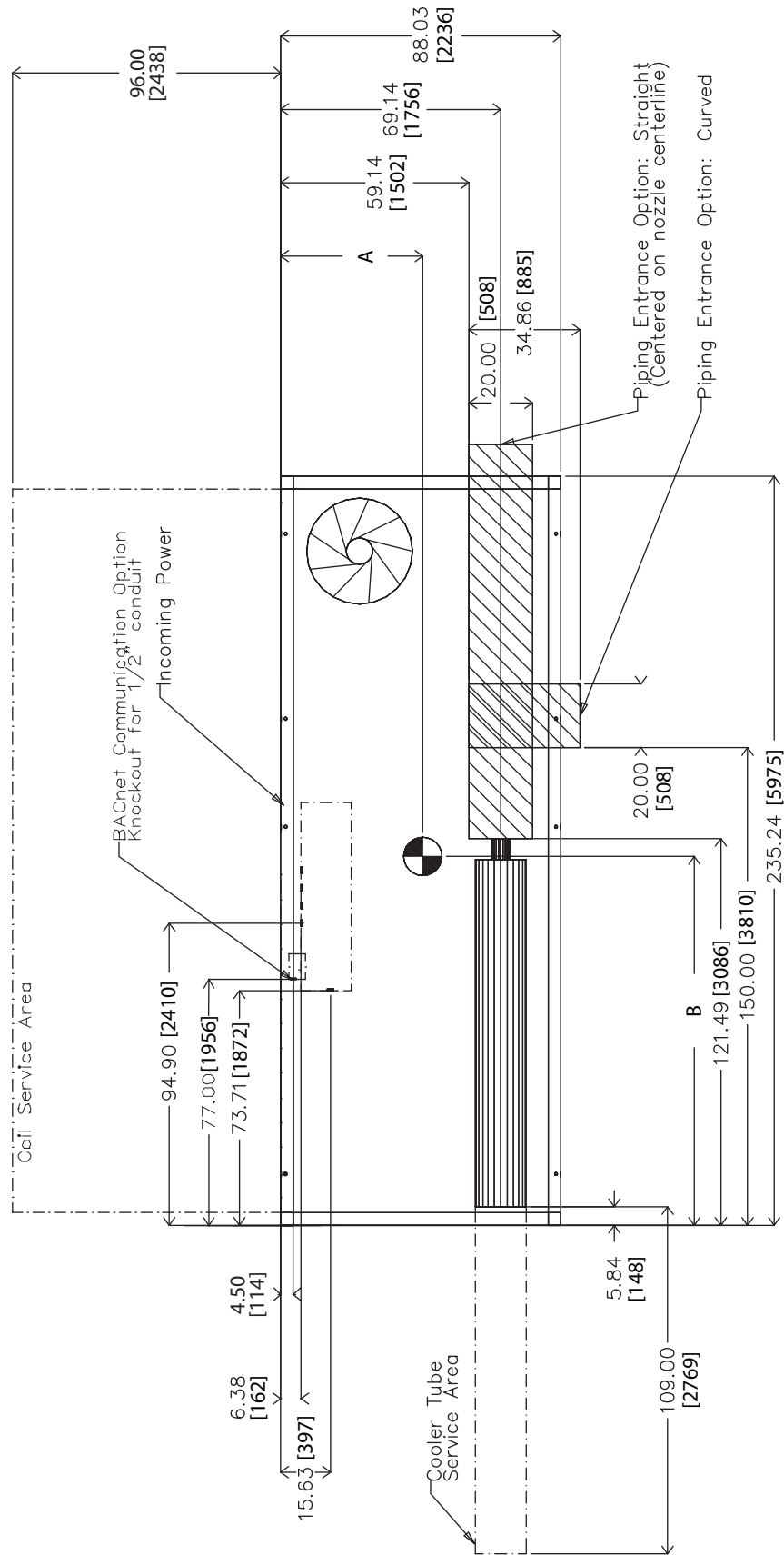

TOP VIEW

30XA140, 160 WITHOUT PUMP (cont)

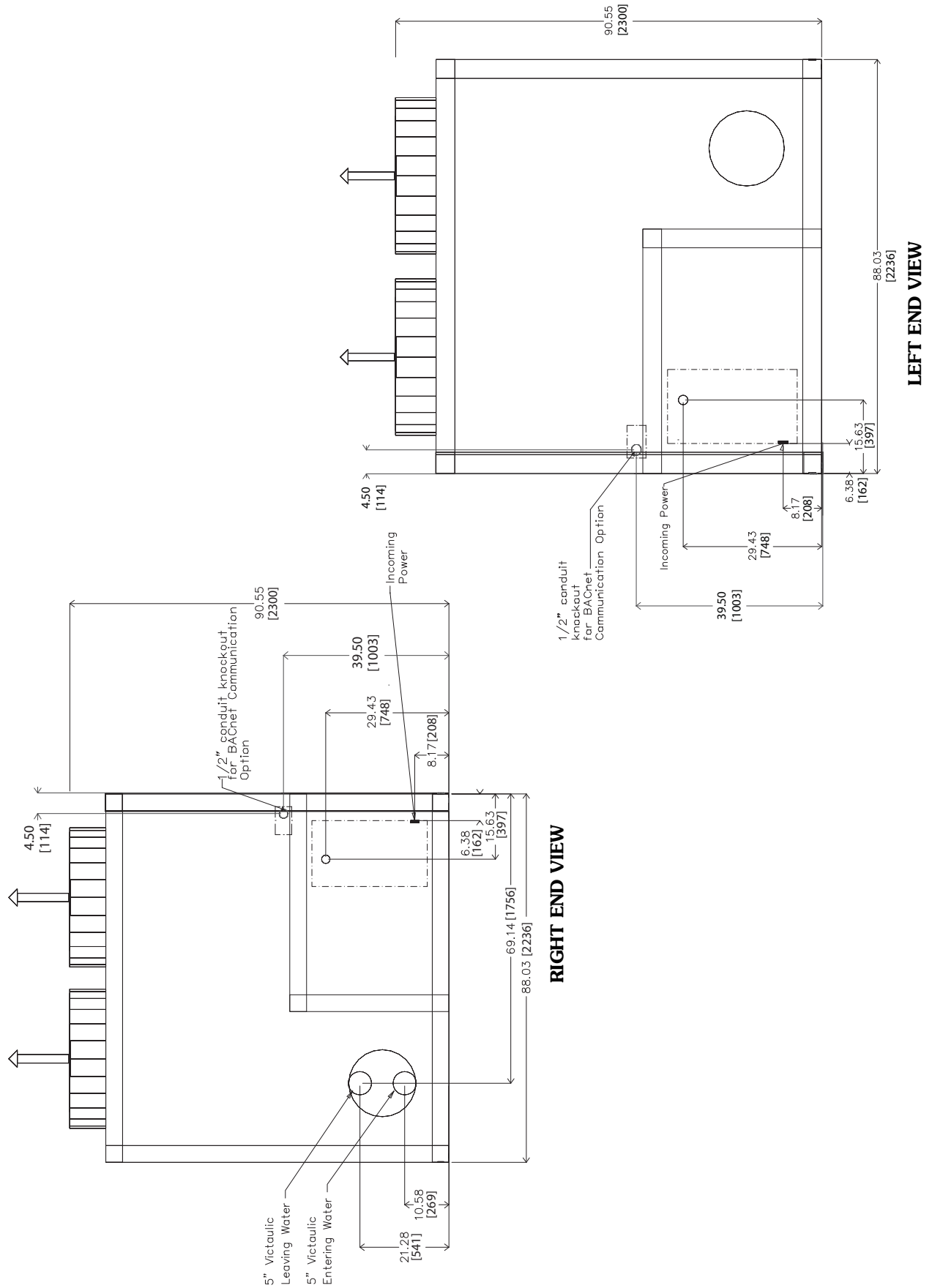

30XA140,160 WITHOUT PUMP (cont)

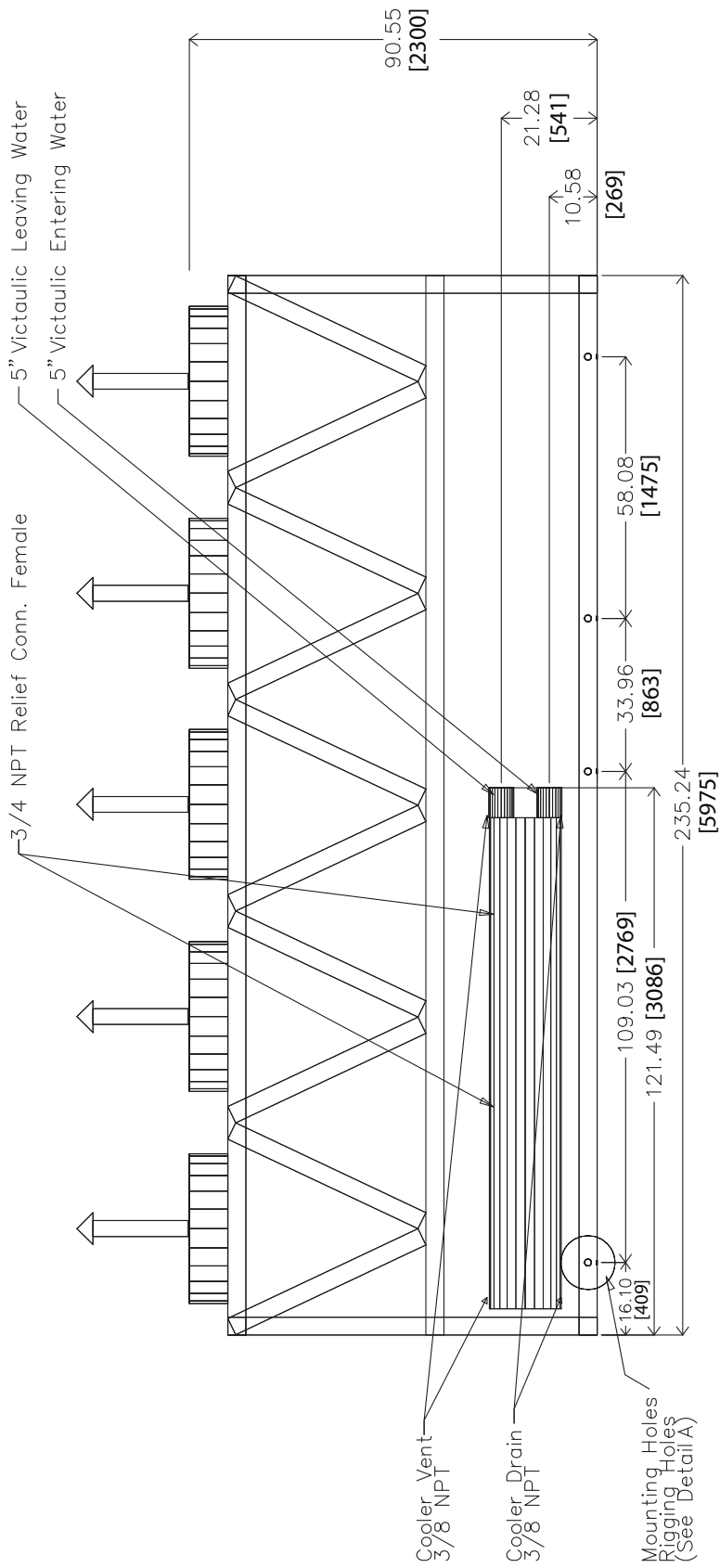
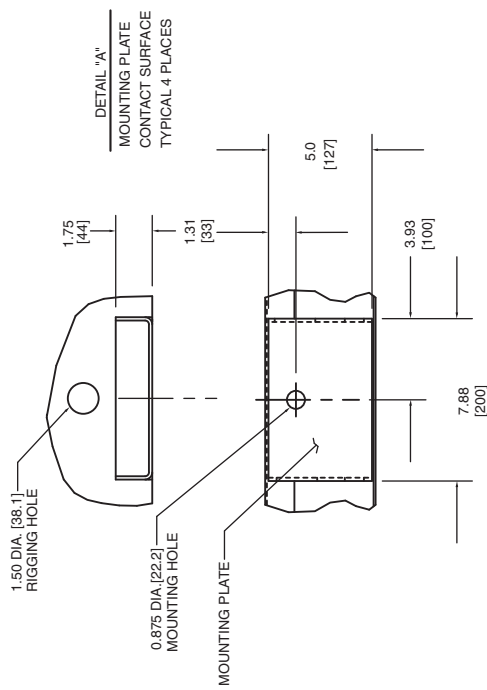

30XA140,160 WITHOUT PUMP (cont)

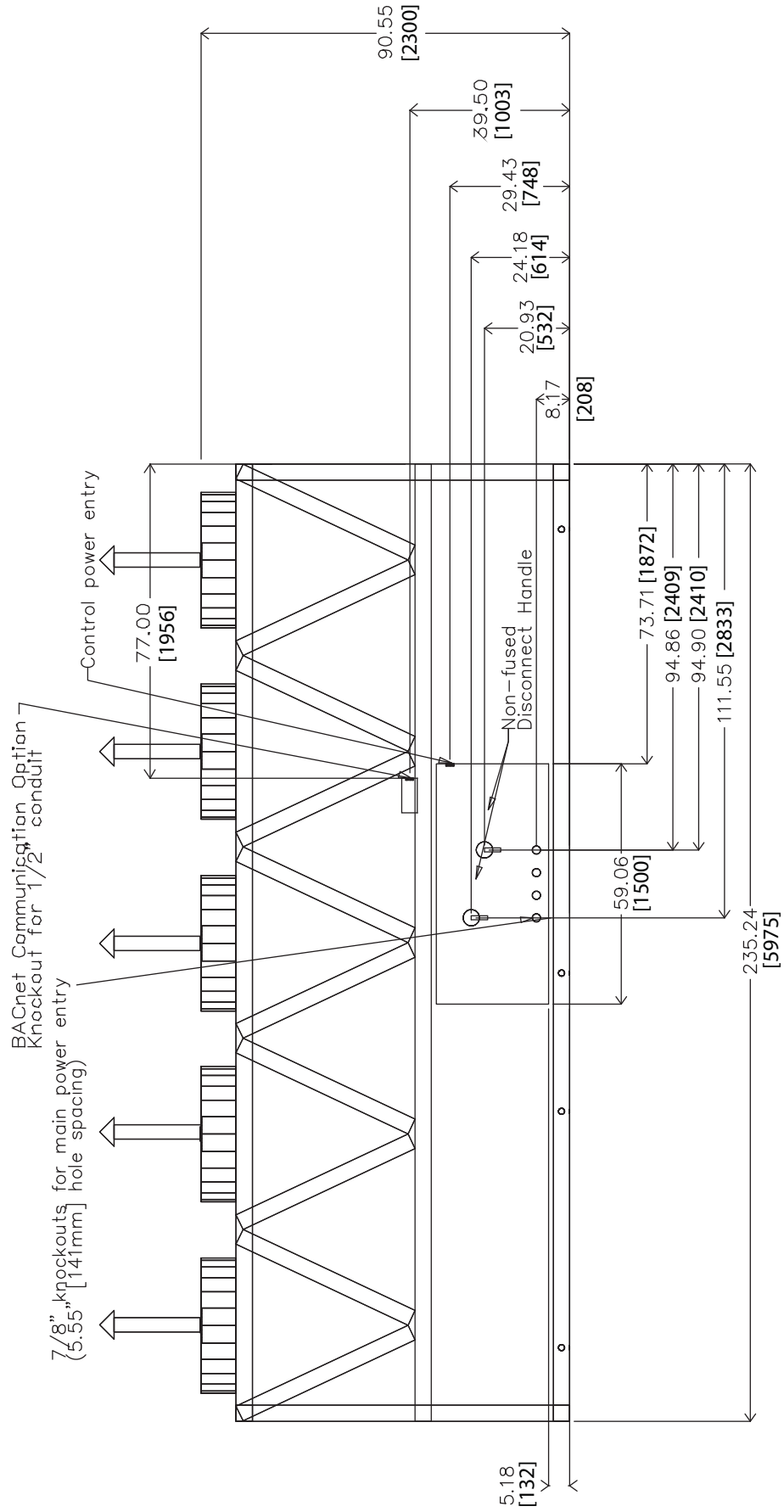

BACK VIEW

30XA140,160 WITH PUMP (SEE NOTE 4)

NOTES:

- Unit must have clearances as follows:
 Top — Do not restrict
 Sides and Ends — 6 ft (1.8 m) from solid surface.
- Temperature relief devices are located on liquid line and economizer assemblies and have 1/4-in. flare connection.
- 3/8-in. NPT vents and drains located in each cooler head at each end of cooler.
- Drawing depicts unit with single-point power, standard two-pass cooler, standard SCCR (short circuit current rating), and nominal voltage range of 380 to 575 v. Refer to the Packaged Chiller Builder program for other configurations.
- Dimensions are shown in inches. Dimensions in [] are in millimeters.

30XA UNIT	A	B
140	44.63 [1134]	115.88 [2943]
160	44.61 [1133]	115.64 [2937]

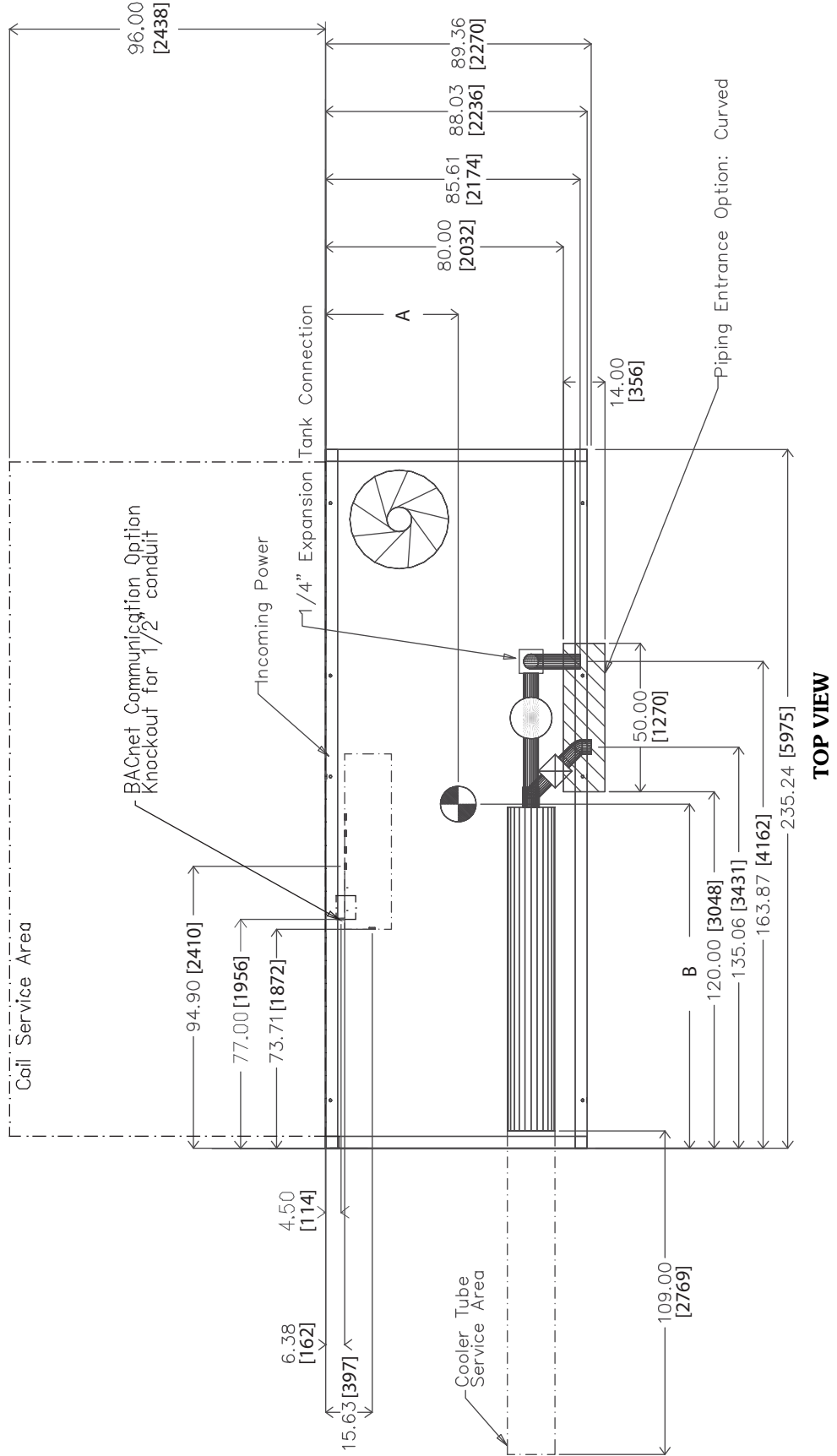

Dimensions (cont)

30XA140,160 WITH PUMP (cont)

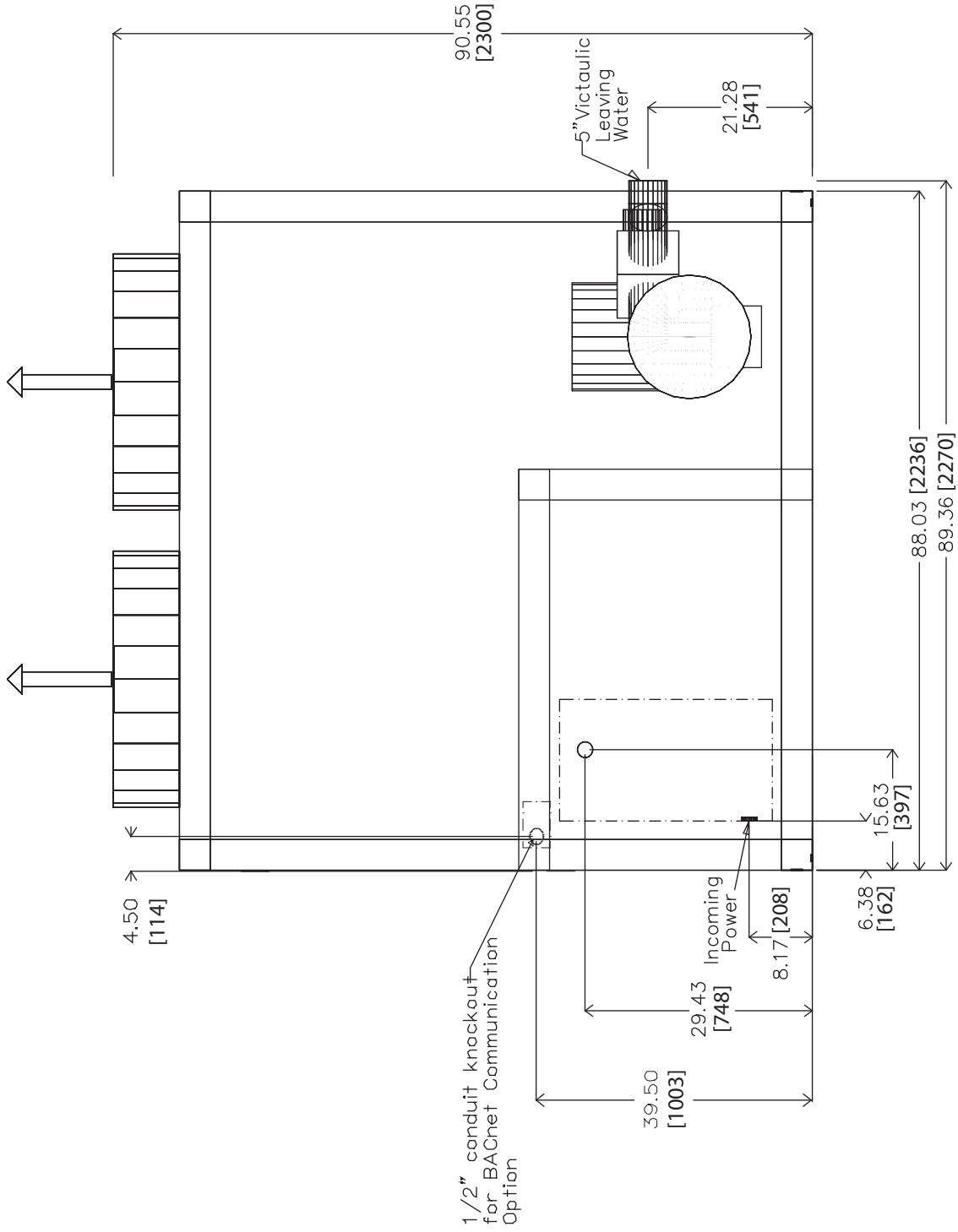

LEFT END VIEW

30XA140,160 WITH PUMP (cont)

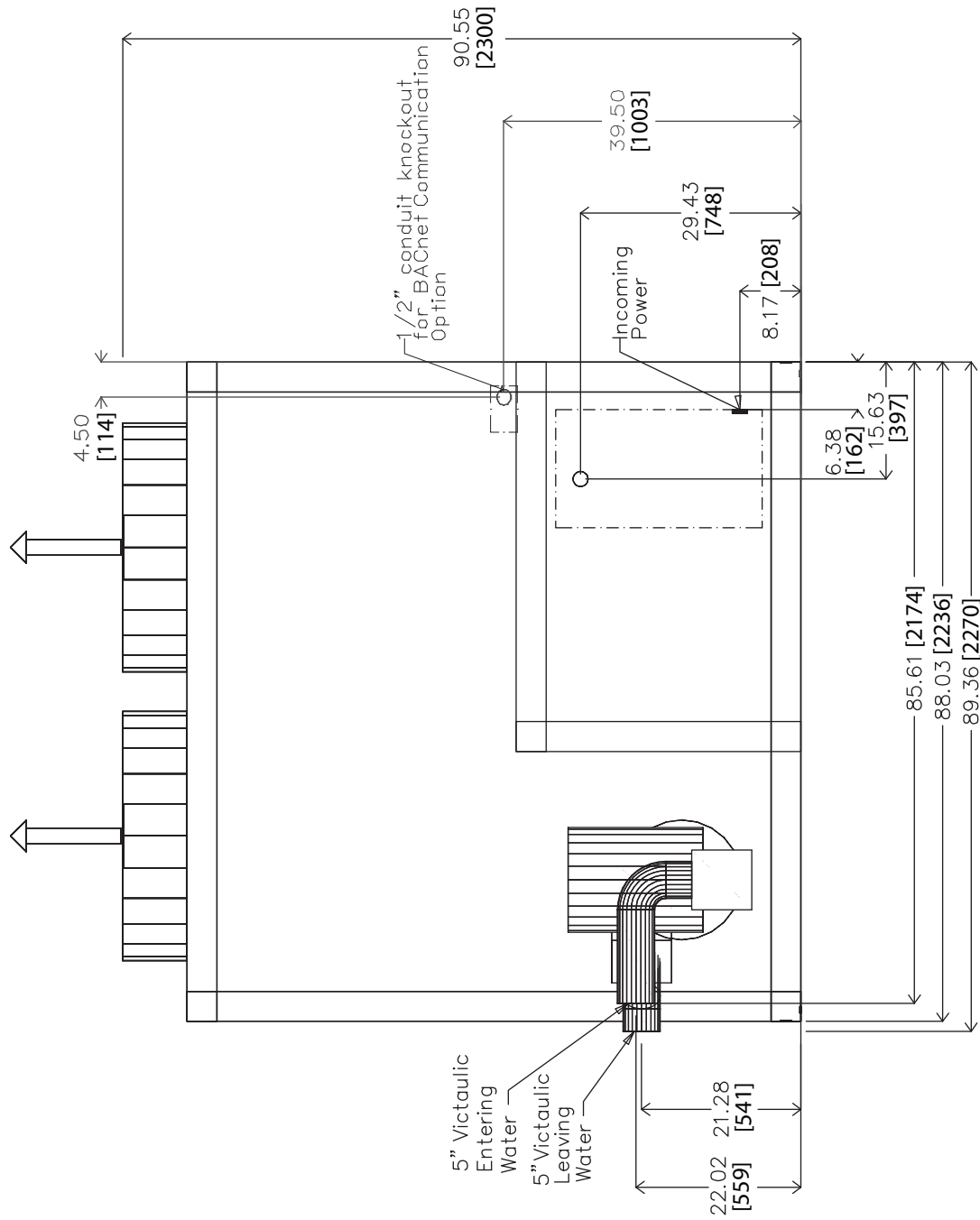

RIGHT END VIEW

30XA140,160 WITH PUMP (cont)

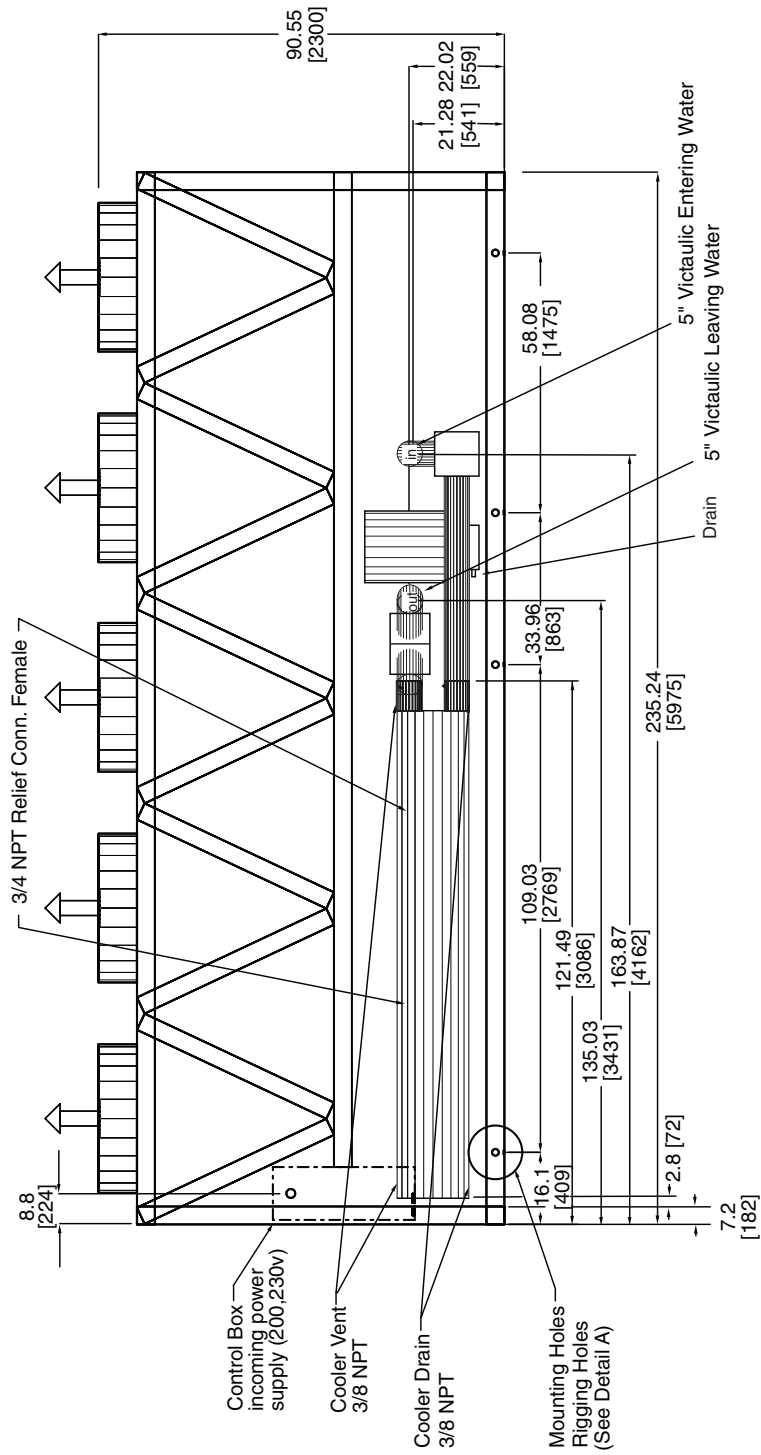
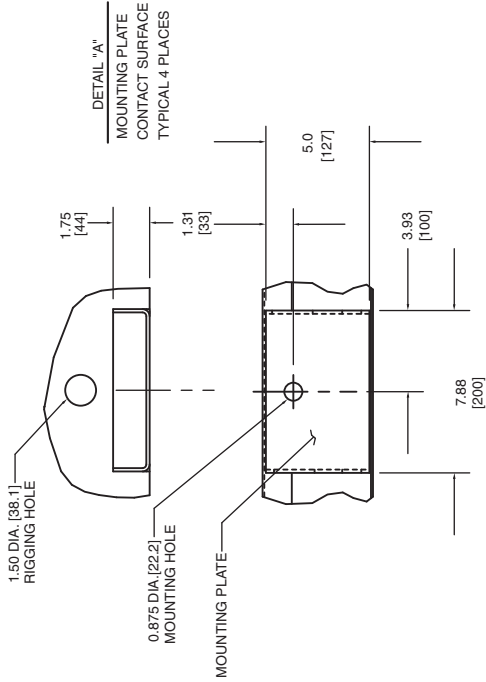

30XA140,160 WITH PUMP (cont)

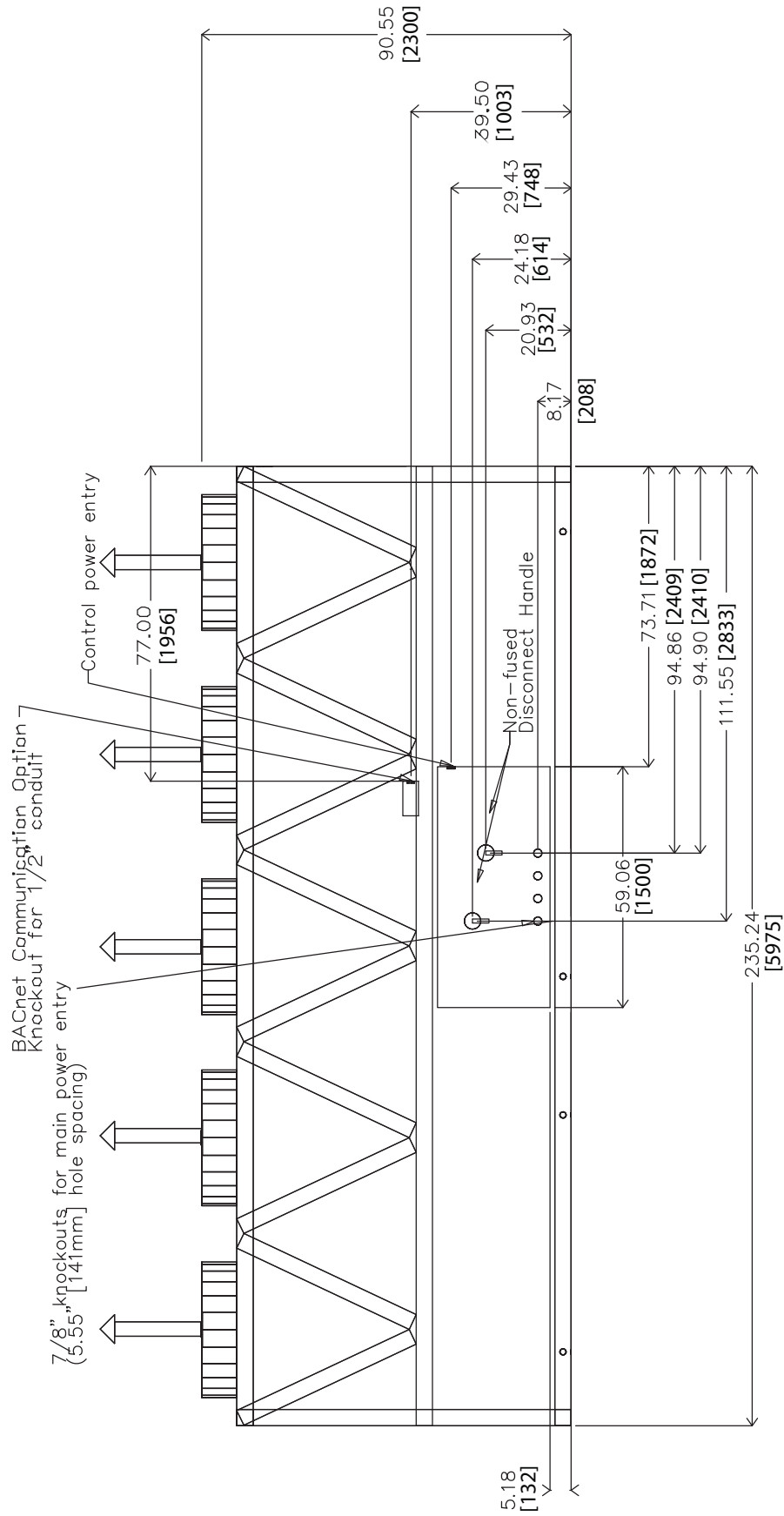

BACK VIEW

30XA142,162 (DX COOLER)

30XA UNIT	CENTER OF GRAVITY		PUMP SUCTION (PS)			PUMP DISCHARGE (PD)		
	CGx	CGy	X ± 0.25	Y ± 0.25	Z ± 0.25	X ± 0.25	Y ± 0.25	Z ± 0.25
142	102.0 [2590.8]	36.0 [914.4]	12.05 [305.97]	10.80 [274.29]	10.41 [264.41]	47.49 [1206.25]	16.15 [410.09]	15.01 [381.25]
162	102.0 [2590.8]	36.0 [914.4]	12.05 [305.97]	10.80 [274.29]	10.41 [264.41]	47.49 [1206.25]	16.15 [410.09]	15.01 [381.25]

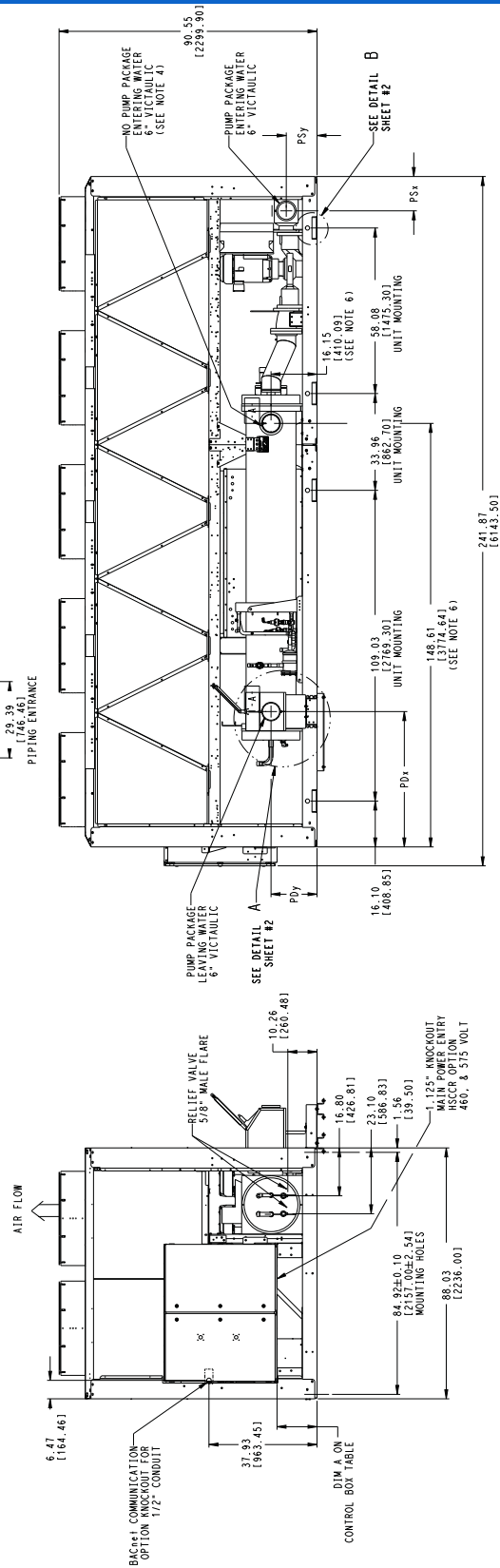
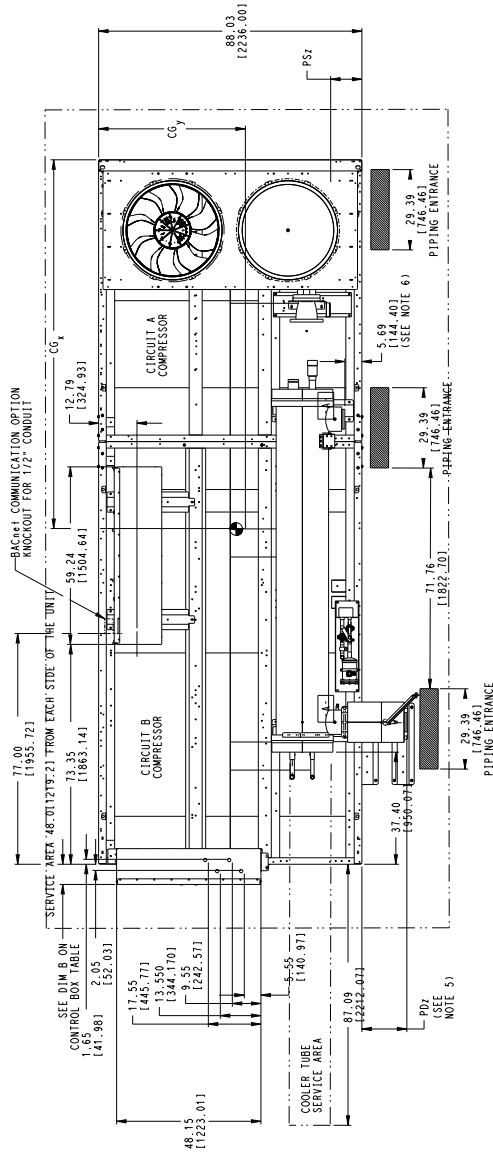

00DCN500004600A

D

NOTES:

- Unit must have clearances as follows:
 - Top — Do not restrict
 - Sides and ends — 6 ft (1.8 m) from solid surface
 - Airflow side — 8 ft (2.4 m) required for coil service area
- All pumps have drains located at the bottom of volute for draining.
- Temperature relief devices are located on liquid lines, and economizer assemblies and have 1/4-in. flare connection.
- No pump package leaving water connection is same size and has same Y and Z dimensions as entering water. Also has same PDx dimension as pump package.
- Leaving water throttling valve and support is factory supplied with pump package, but must be field installed.
- Dimensions for entering water without hydronic kit option are as shown in the drawing.
- Pressure relief devices are located on the cooler (5/8-in. NPT male connector) and on each oil separator (3/8-in. flare connector).
- Dimensions are shown in inches. Dimensions in [] are in millimeters.

CONTROL BOX	A	B
STD BOX	22.04 [568.96]	7.87 [199.89]
HSCCR BOX	14.04 [356.61]	6.74 [171.19]

00DCN500004600A D

30XA142,162 (DX COOLER) (cont)

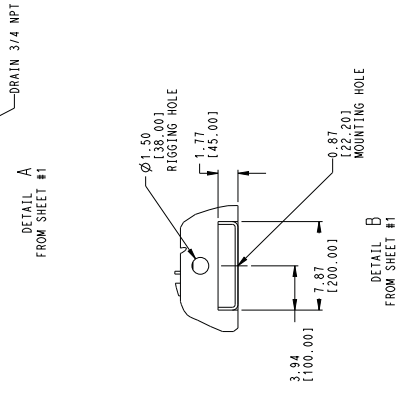
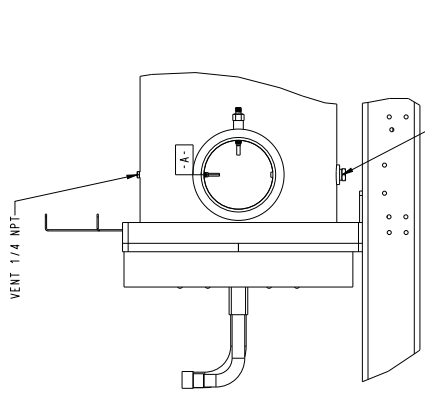
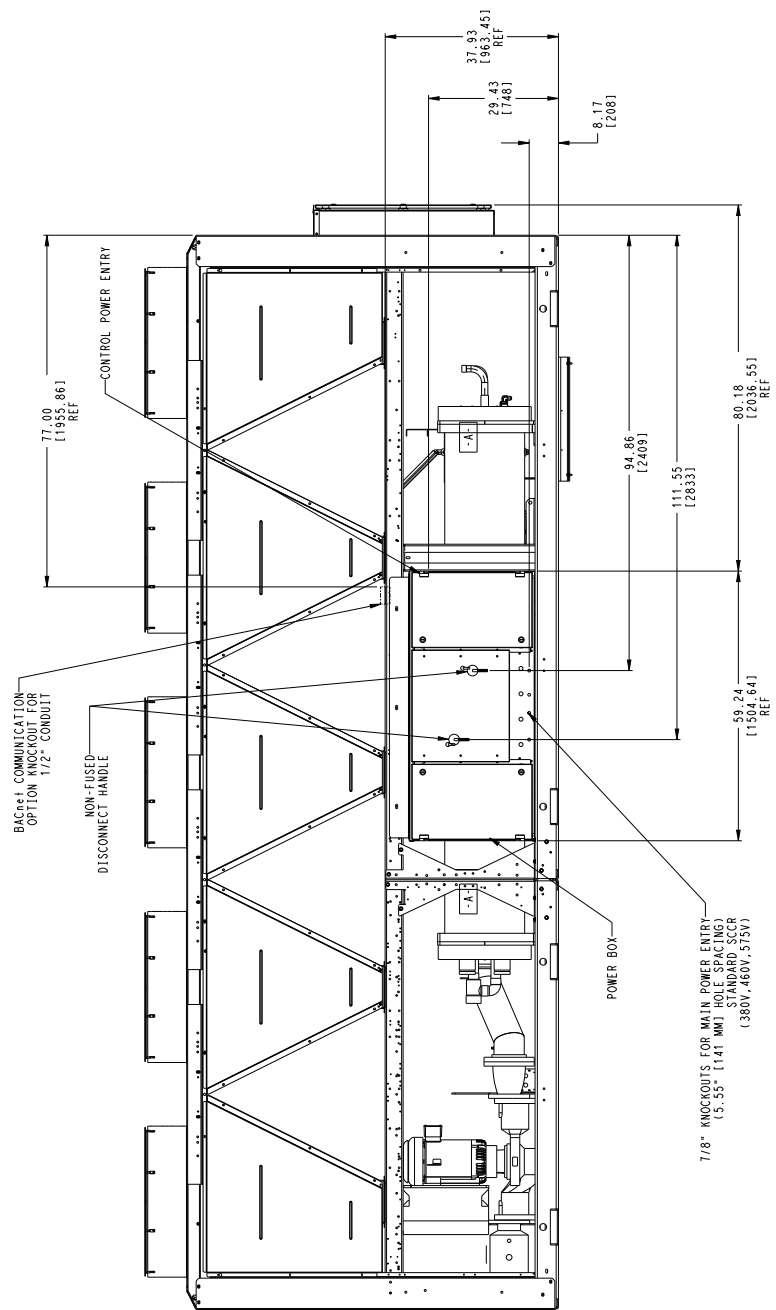

30XA180,200 (SEE NOTE 4)

NOTES:

- Unit must have clearances as follows:
Top — Do not restrict
Sides and Ends — 6 ft (1.8 m) from solid surface.
Temperature relief devices are located on liquid line and economizer assemblies and have 1/4-in. flare connection.
- 3/8-in. NPT vents and drains located in each cooler head at each end of cooler.
- Drawing depicts unit with single point power, standard two-pass cooler, standard SCCR (short circuit current rating), and a nominal voltage range of 380 to 575 v. Refer to the Packaged Chiller Builder program for other configurations.
- Dimensions are shown in inches. Dimensions in [] are in millimeters.

30XA UNIT	A	B
180	46.12 [1171]	143.04 [3633]
200	46.15 [1172]	142.97 [3631]

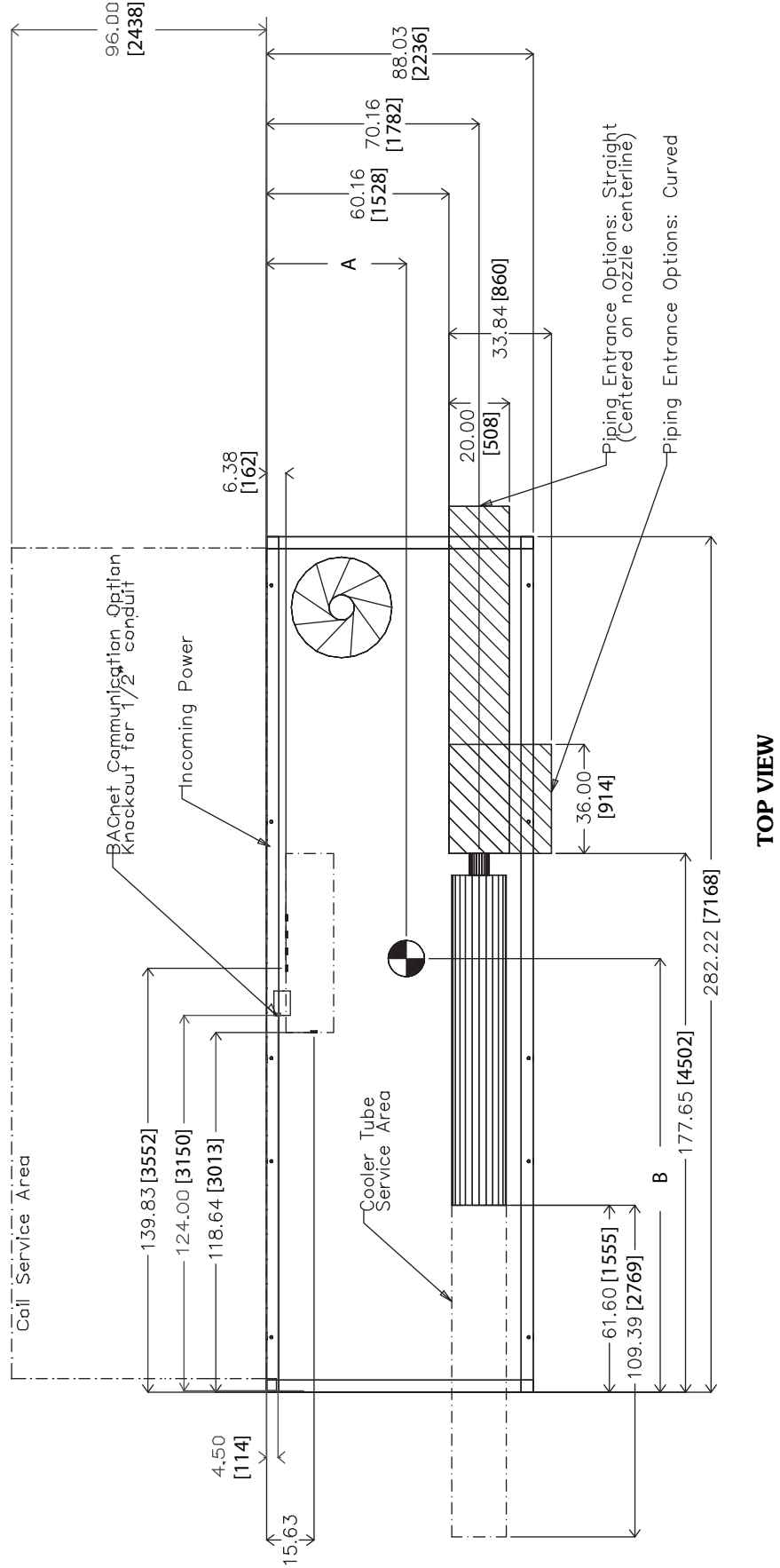

TOP VIEW

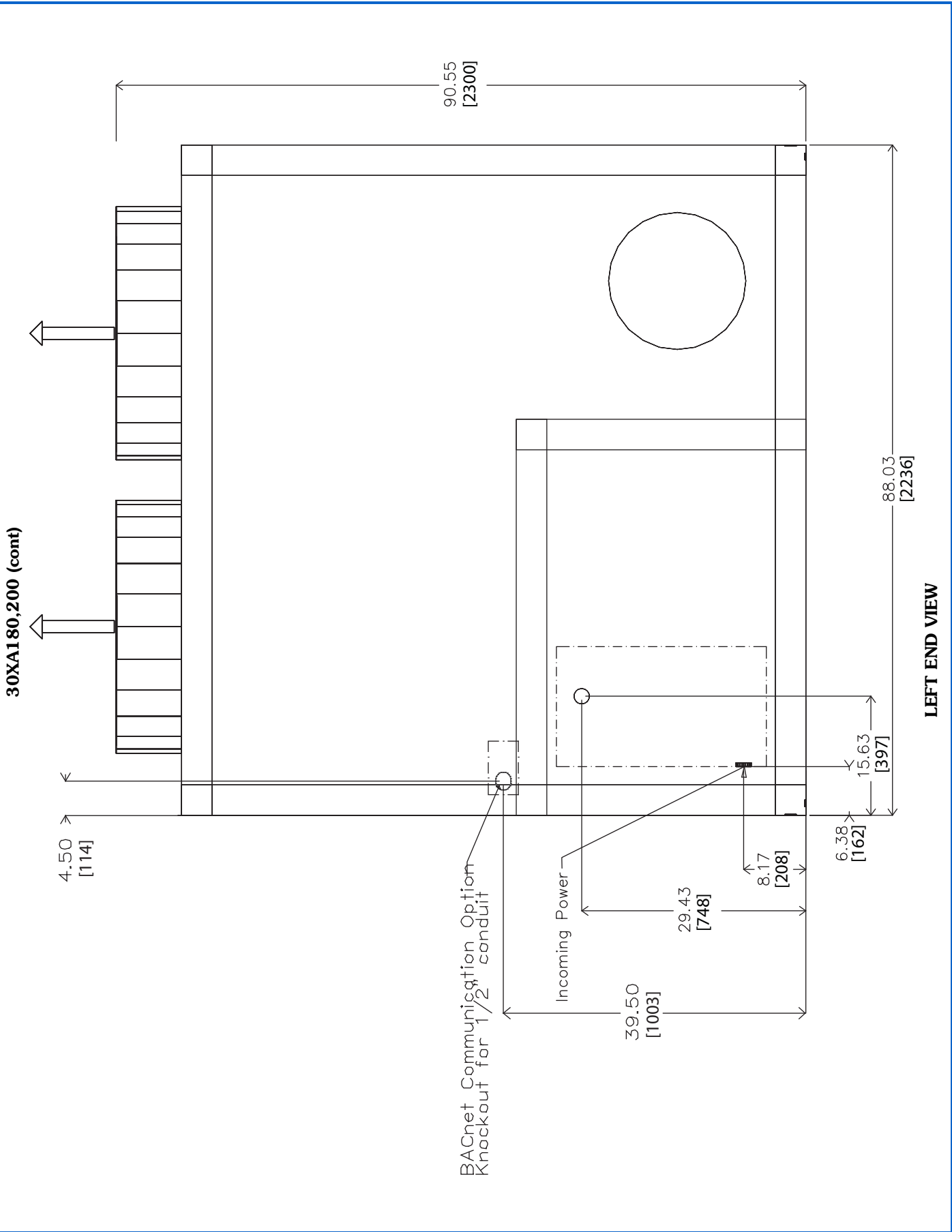

30XA180,200 (cont)

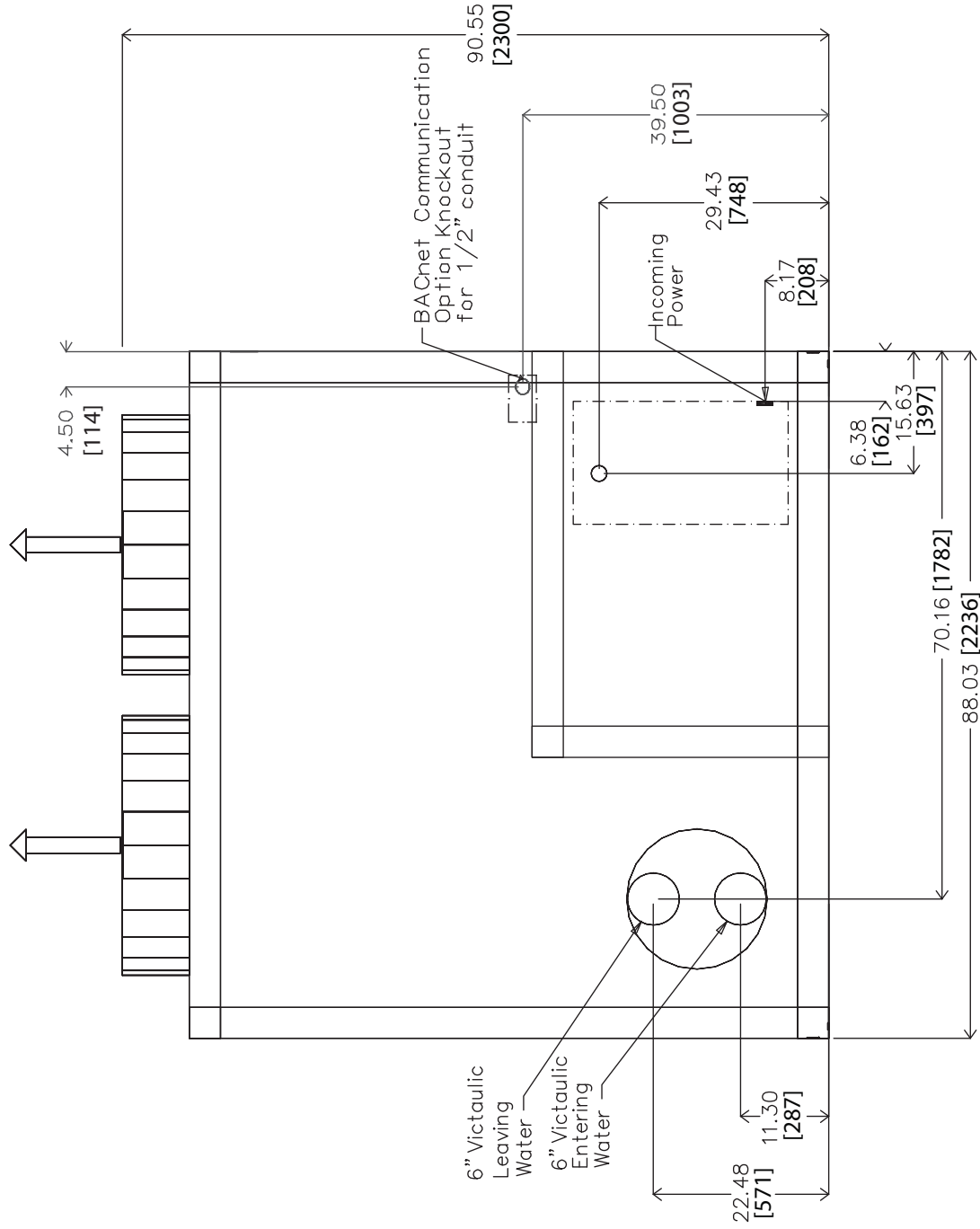

RIGHT END VIEW

30XA180,200 (cont)

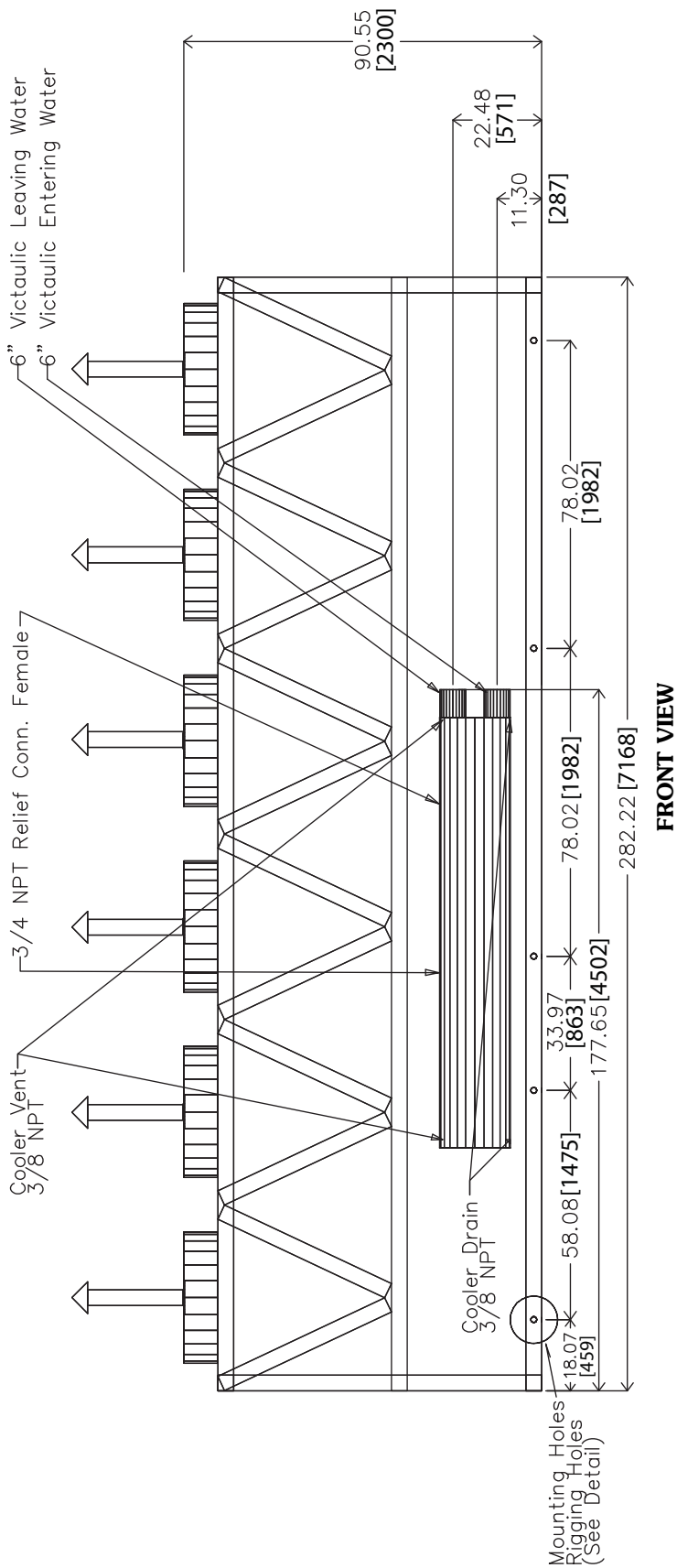
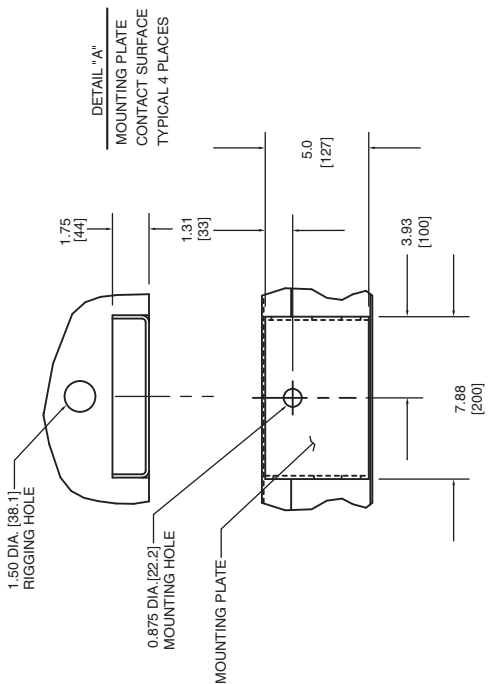

30XA180,200 (cont)

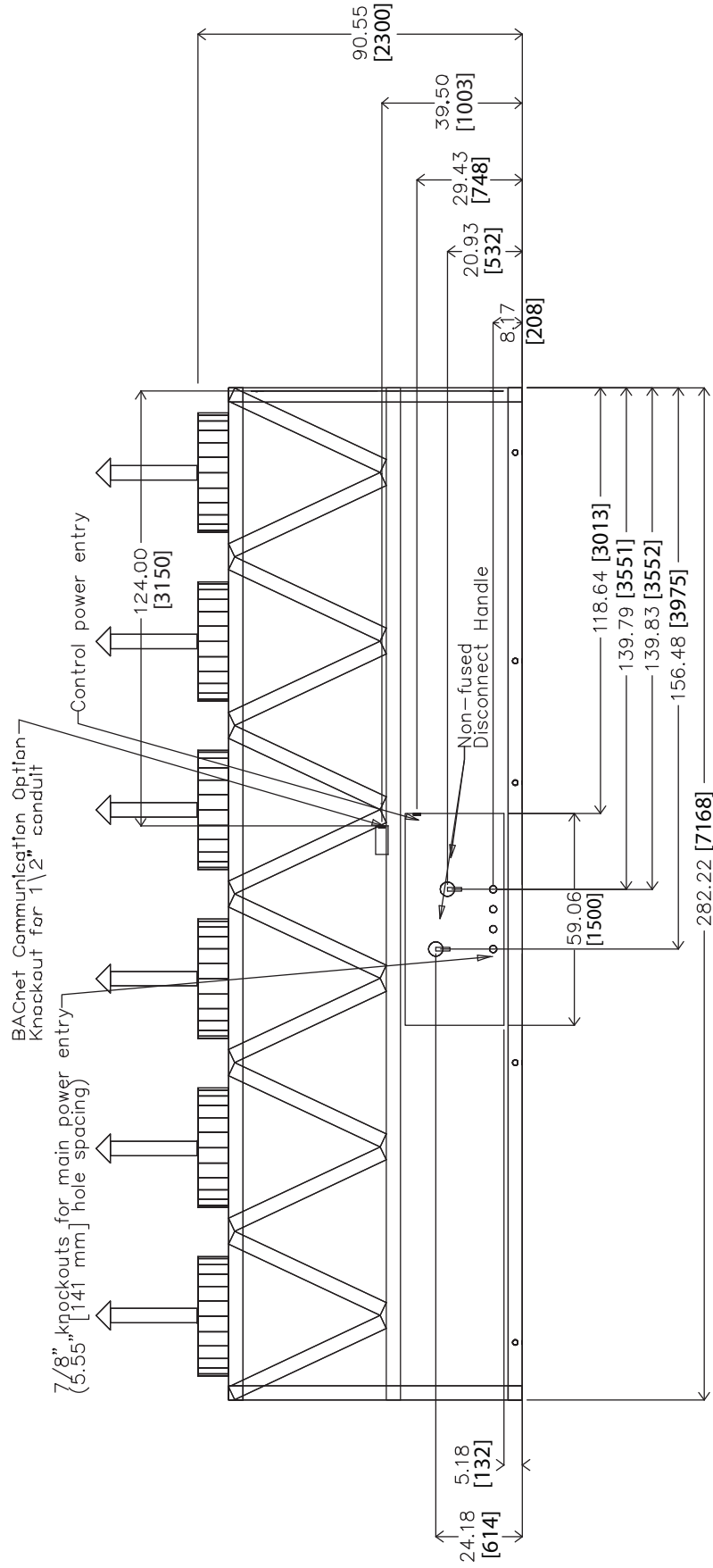

BACK VIEW

30XA182,202 (DX COOLER)

NOTES:

1. Unit must have clearances as follows:
 Top — Do not restrict
 Sides and Ends — 6 ft (1.8 m) from solid surface
 Airflow side — 8 ft (2.4 m) required for coil service area
2. Temperature relief devices located on liquid lines and economizer assemblies and have 1/4-in. flare connection.
3. Pressure relief devices are located on the cooler (5/8-in. NPT male connector) and on each oil separator (3/8-in. flare connector).
4. Dimensions are shown in inches. Dimensions in [] are in millimeters.

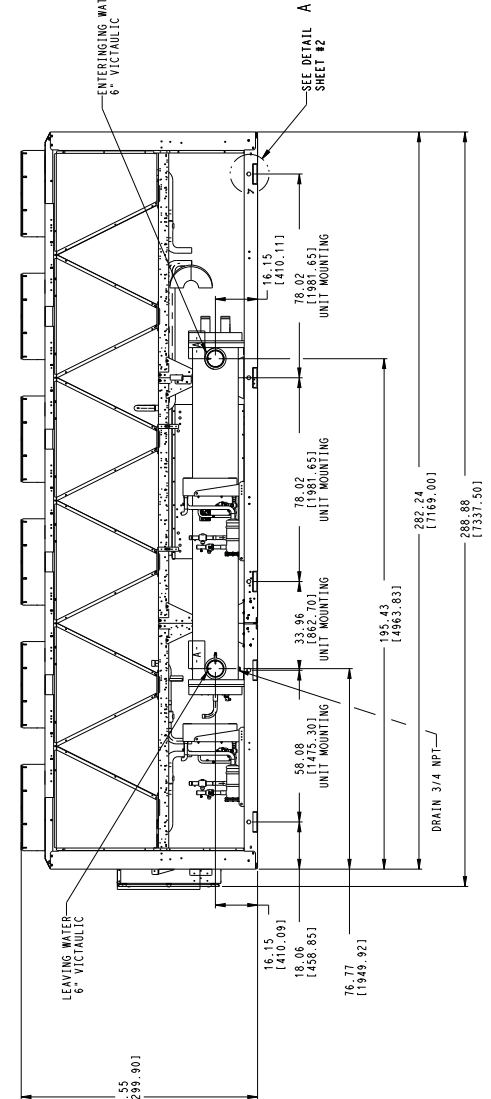
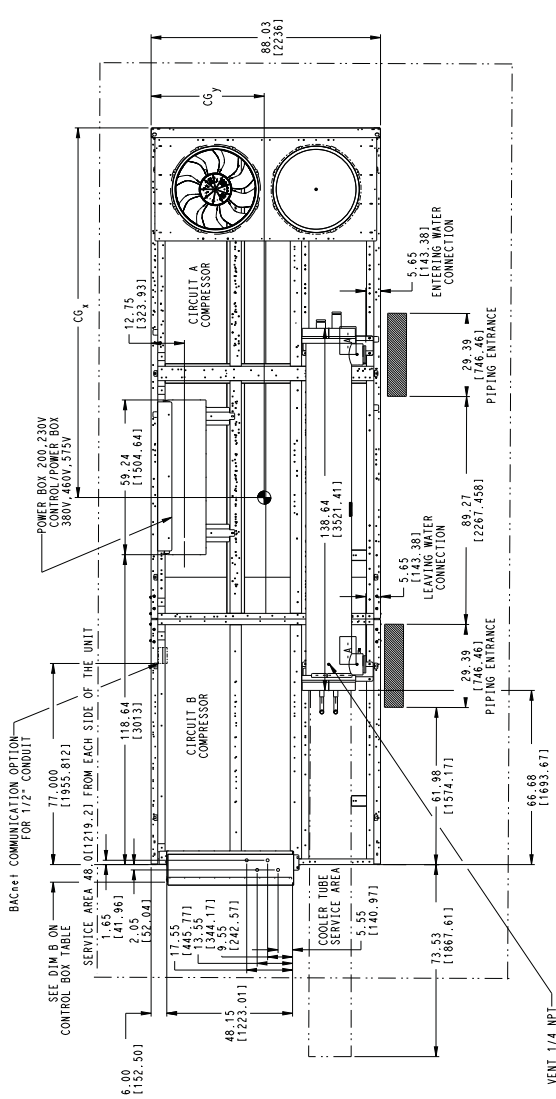

30XA UNIT	CENTER OF GRAVITY	
	CGX	CGY
182	138.0 [3505.2]	38.0 [965.2]
202	138.0 [3505.2]	38.0 [965.2]

CONTROL BOX	A	B
STD BOX	22.04 [568.96]	7.87 [199.89]
HSCCR BOX	14.04 [356.61]	6.74 [171.19]

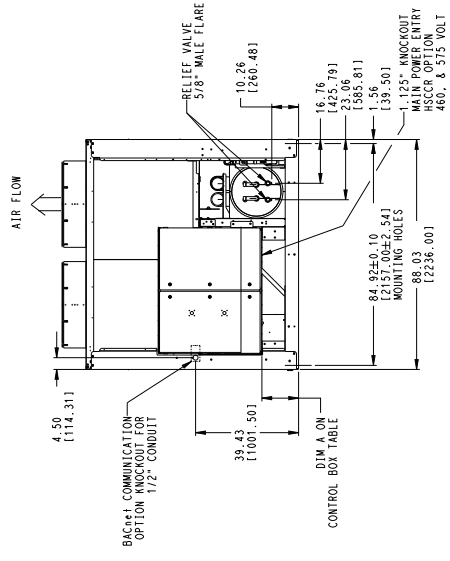

00DCN500004700A E

30XA182,202 (DX COOLER) (cont)

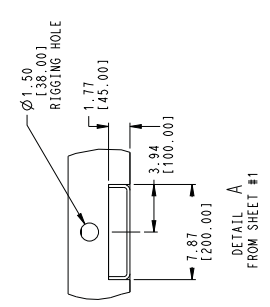
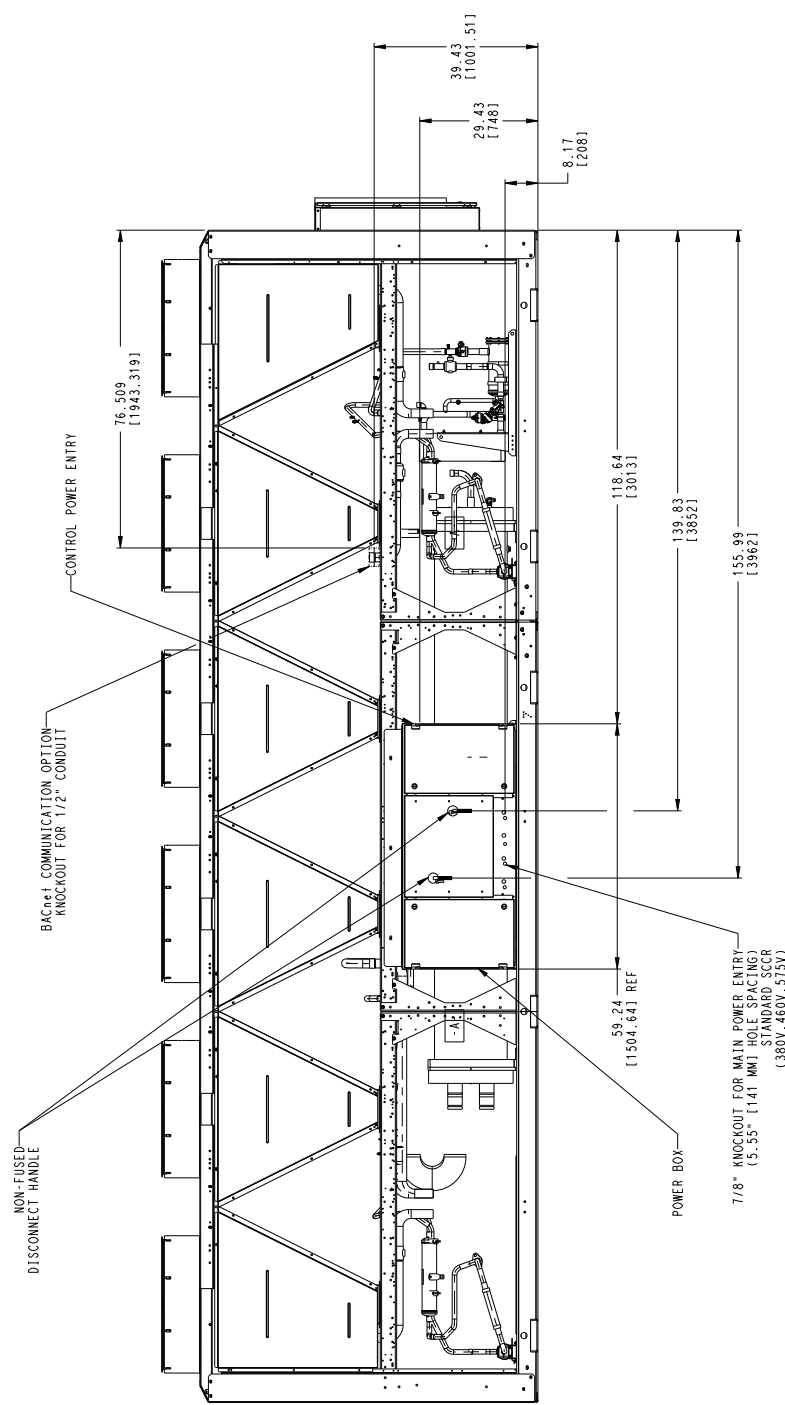

00DCN500004700A E

30XA220,240 (SEE NOTE 4)

NOTES:

1. Unit must have clearances as follows:
 Top — Do not restrict
 Sides and Ends — 6 ft (1.8 m) from solid surface.
2. Temperature relief devices are located on liquid line and economizer assemblies and have 1/4-in. flare connection.
3. 3/8-in. NPT vents and drains located in each cooler head at each end of cooler.
4. Drawing depicts unit with single point power, standard two-pass cooler standard SCCR (short circuit current rating), and nominal voltage range of 380 to 575 v. Refer to the Packaged Chiller Builder program for other configurations.
5. Dimensions are shown in inches. Dimensions in [] are in millimeters.

30XA UNIT	A	B
220	46.17 [1173]	171.42 [4354]
240	46.23 [1174]	170.83 [4339]

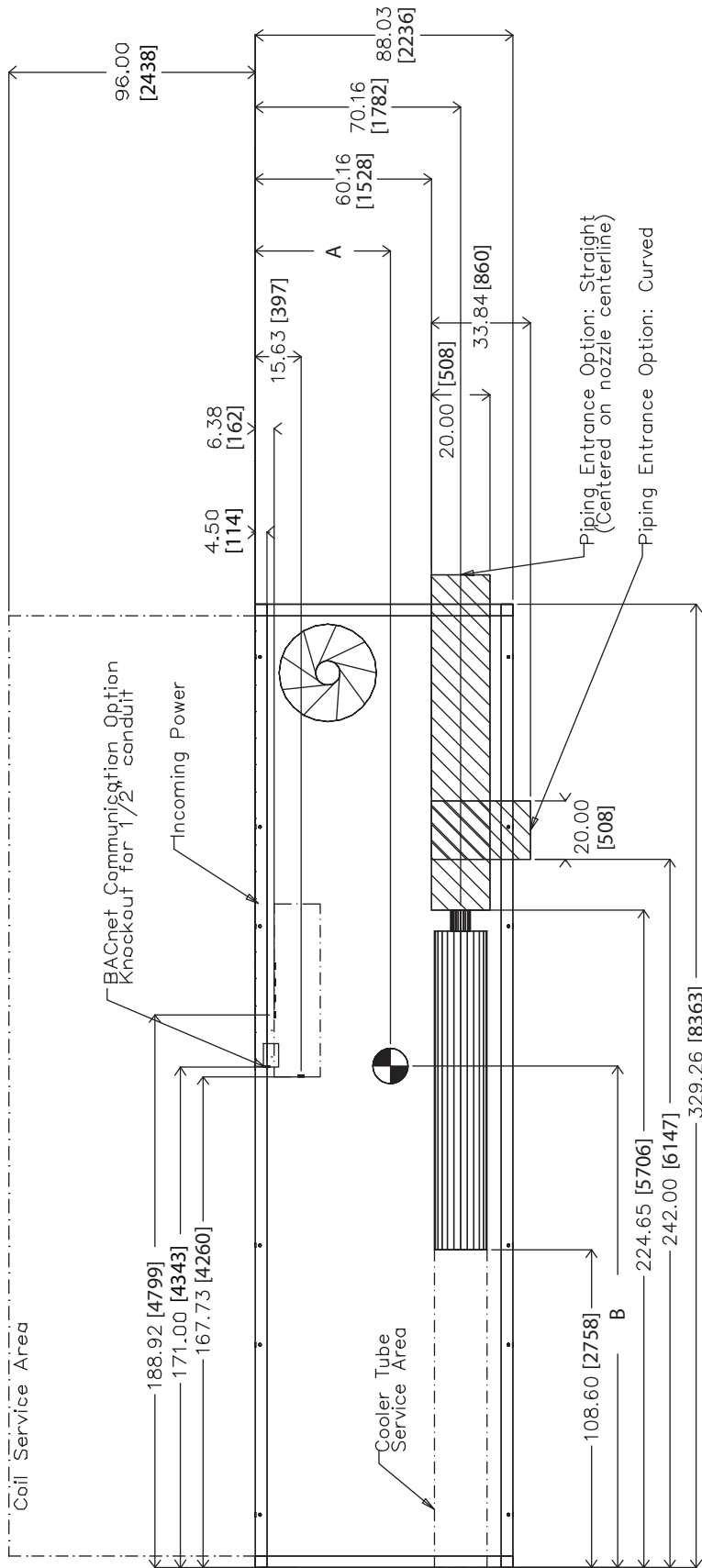

TOP VIEW

Dimensions (cont)

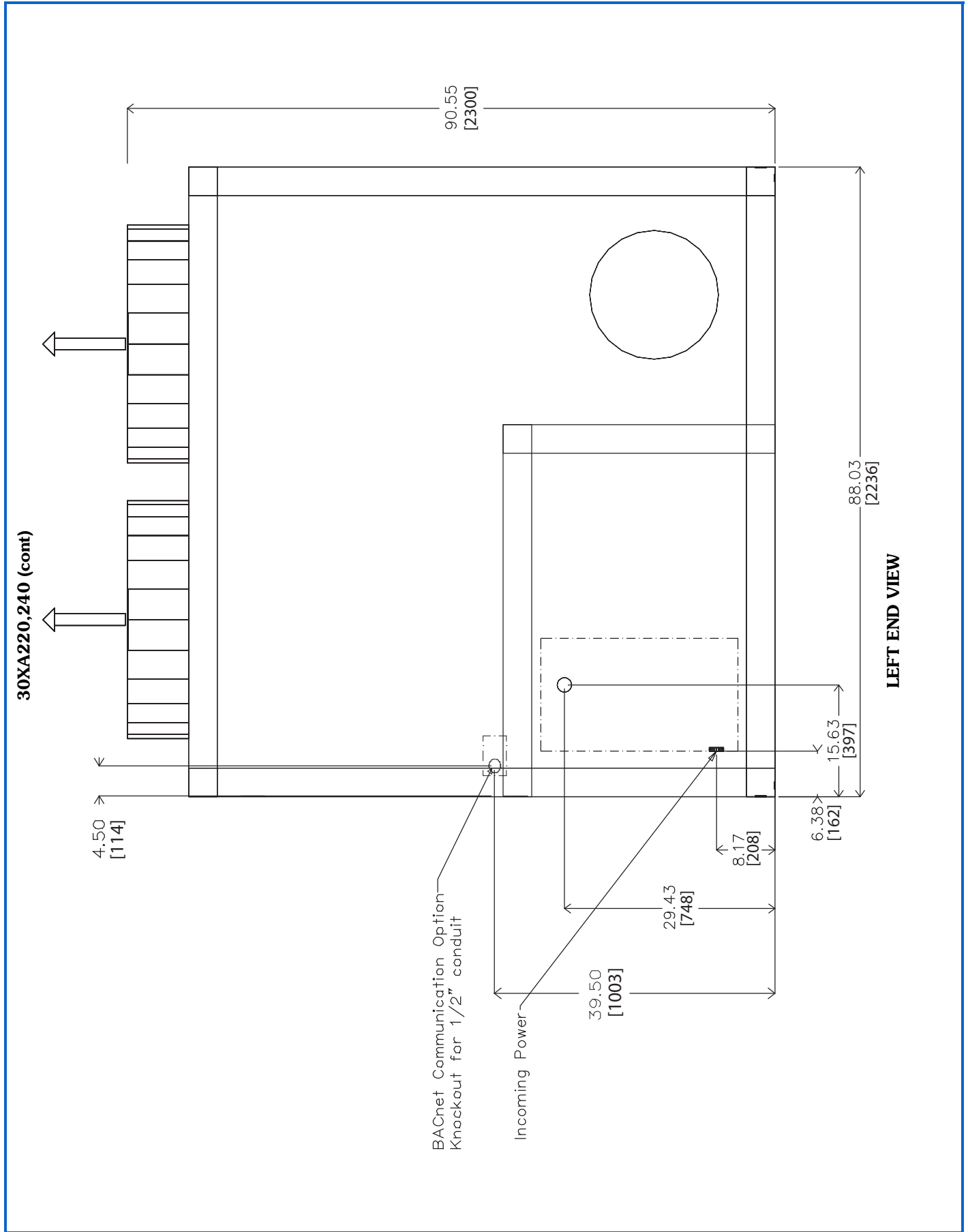

30XA220,240 (cont)

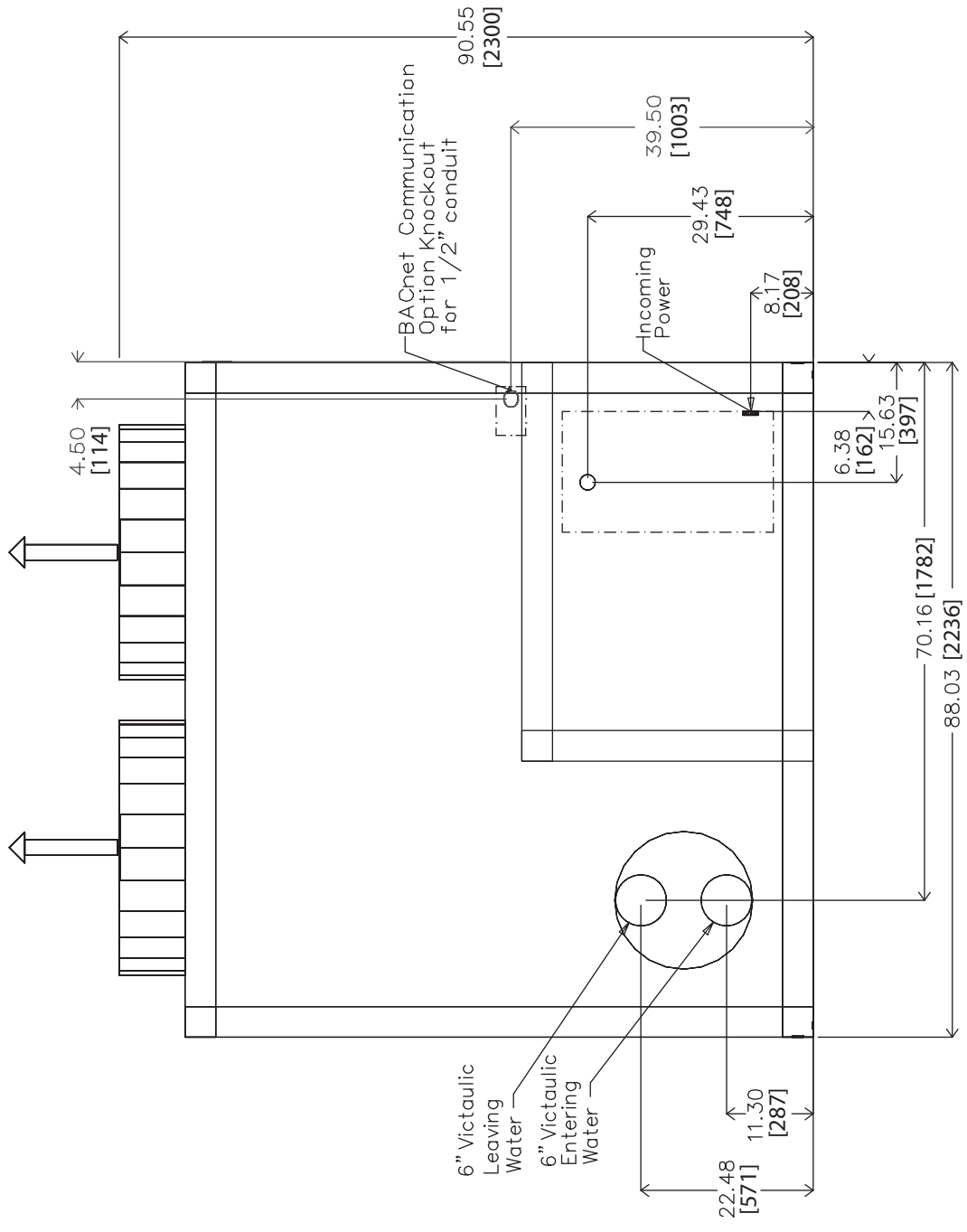

RIGHT END VIEW

30XA220,240 (cont)

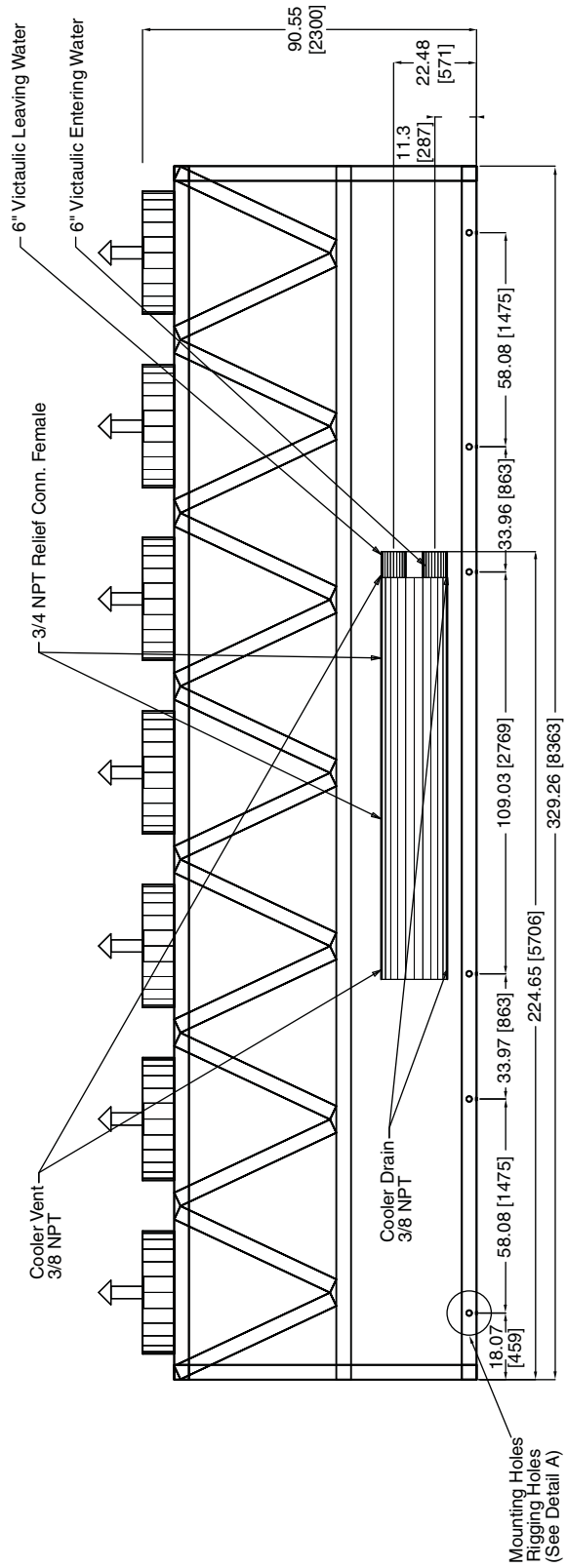
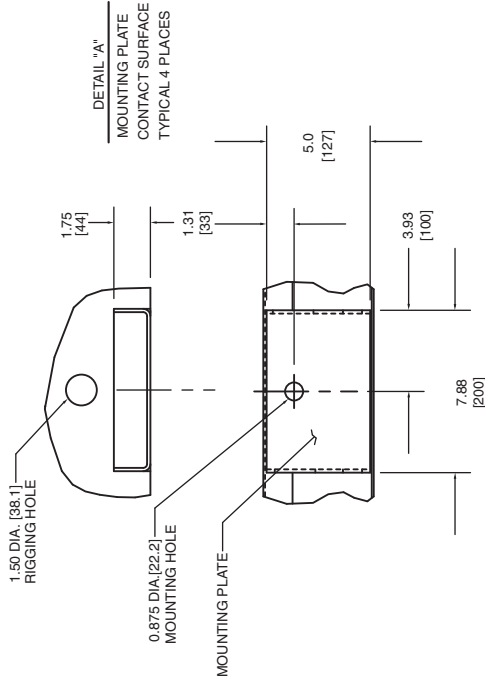

FRONT VIEW

FRONT VIEW

30XA220,240 (cont)

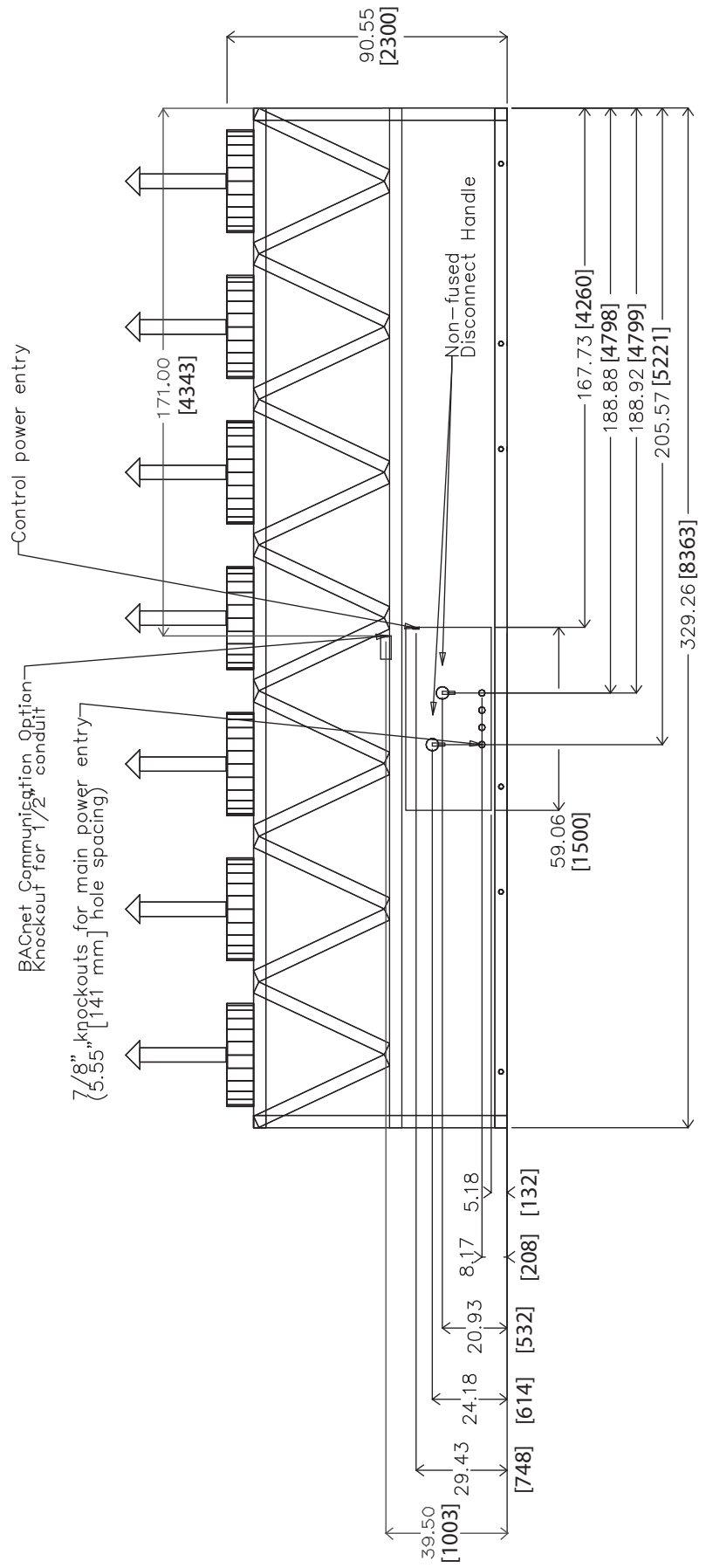

BACK VIEW

30XA222,242 (DX COOLER)

NOTES:

- Unit must have clearances as follows:
 Top — Do not restrict
 Sides and end — 6 ft (1.8 m) from solid surface
 Airflow side — 8 ft (2.4 m) required for coil service area
- Temperature relief devices are located on liquid line and economizer assemblies and have 1/4-in. flare connection.
- Pressure relief devices are located on the cooler arator (5/8-in. NPT male connector) and on each oil separator (3/8-in. flare connection).
- Dimensions are shown in inches. Dimensions in [] are in millimeters.

30XA UNIT	CGx	CGy
222	157.73 [4006]	46.17 [1173]
242	158.32 [4021]	46.23 [1174]

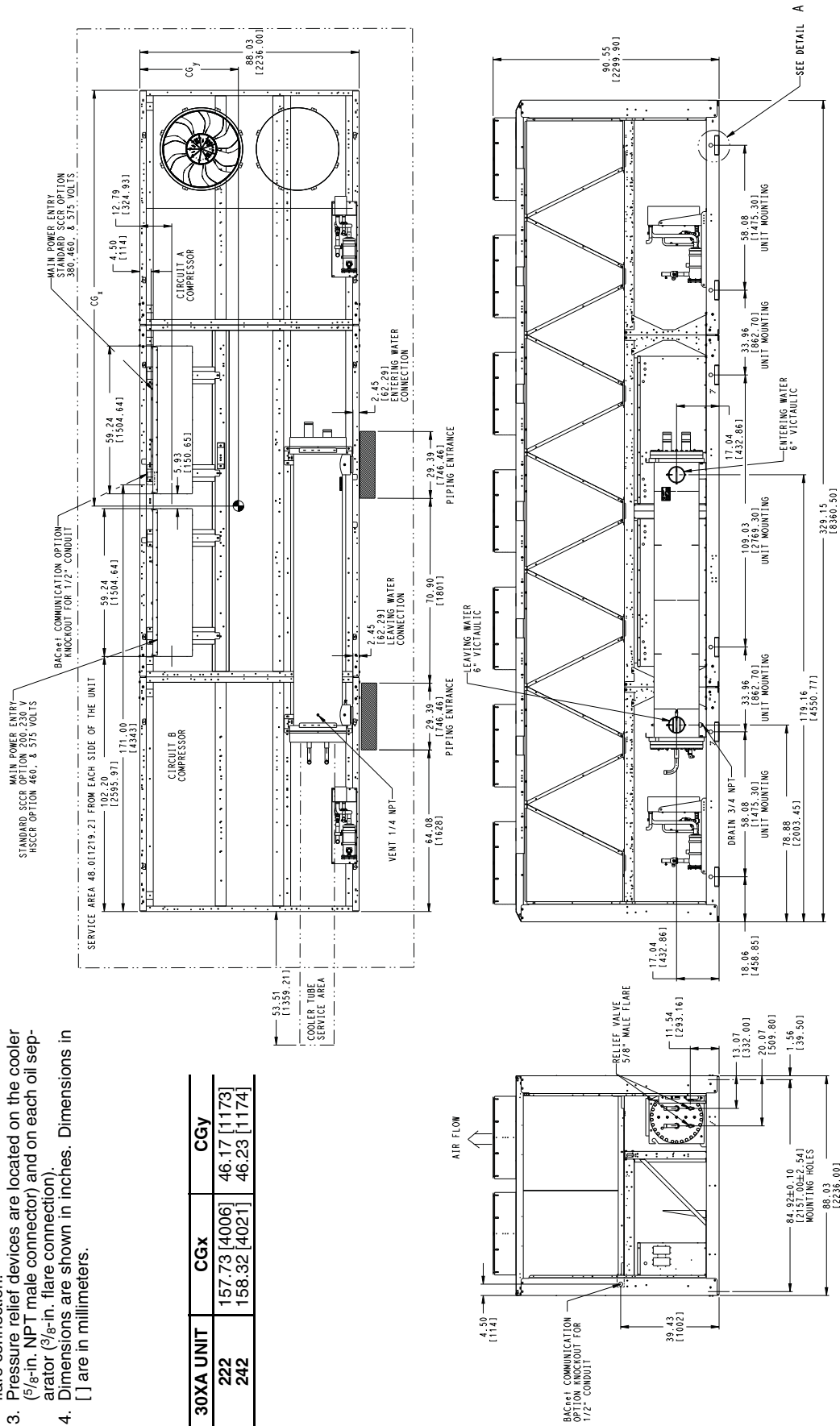

00DCN500004900A D

30XA222,242 (DX COOLER) (cont)

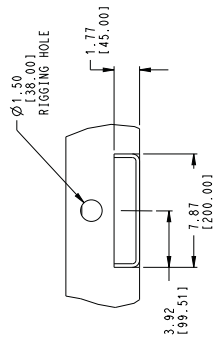
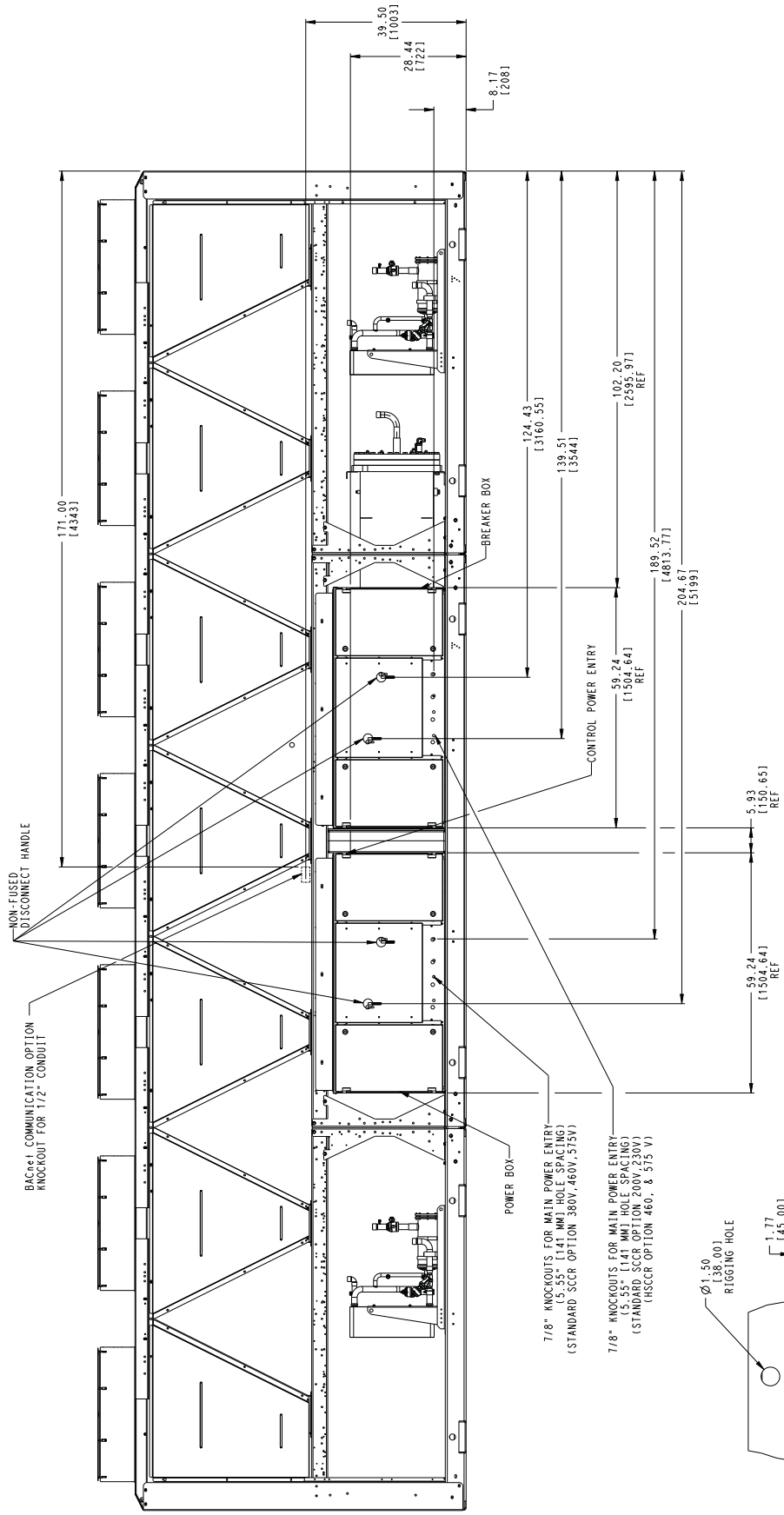

00DCN500004900A D

30XA260,280,300 (SEE NOTE 4)

NOTES:

- Unit must have clearances as follows:
Top — Do not restrict
Sides and Ends — 6 ft (1.8 m) from solid surface.
- Temperature relief devices are located on liquid line and economizer assemblies and have 1/4-in. flare connection.
- 3/8-in. NPT vents and drains located in each cooler head at each end of cooler.
- Drawing depicts unit with single point power, standard two-pass cooler, and standard SCRR (short circuit current rating). Refer to the Packaged Chiller Builder program for other configurations.
- Dimensions are shown in inches. Dimensions in [] are in millimeters.

30XA UNIT	A	B
260	44.22 [1123]	216.16 [5490]
280	44.30 [1125]	215.86 [5483]
300	44.32 [1126]	216.18 [5491]

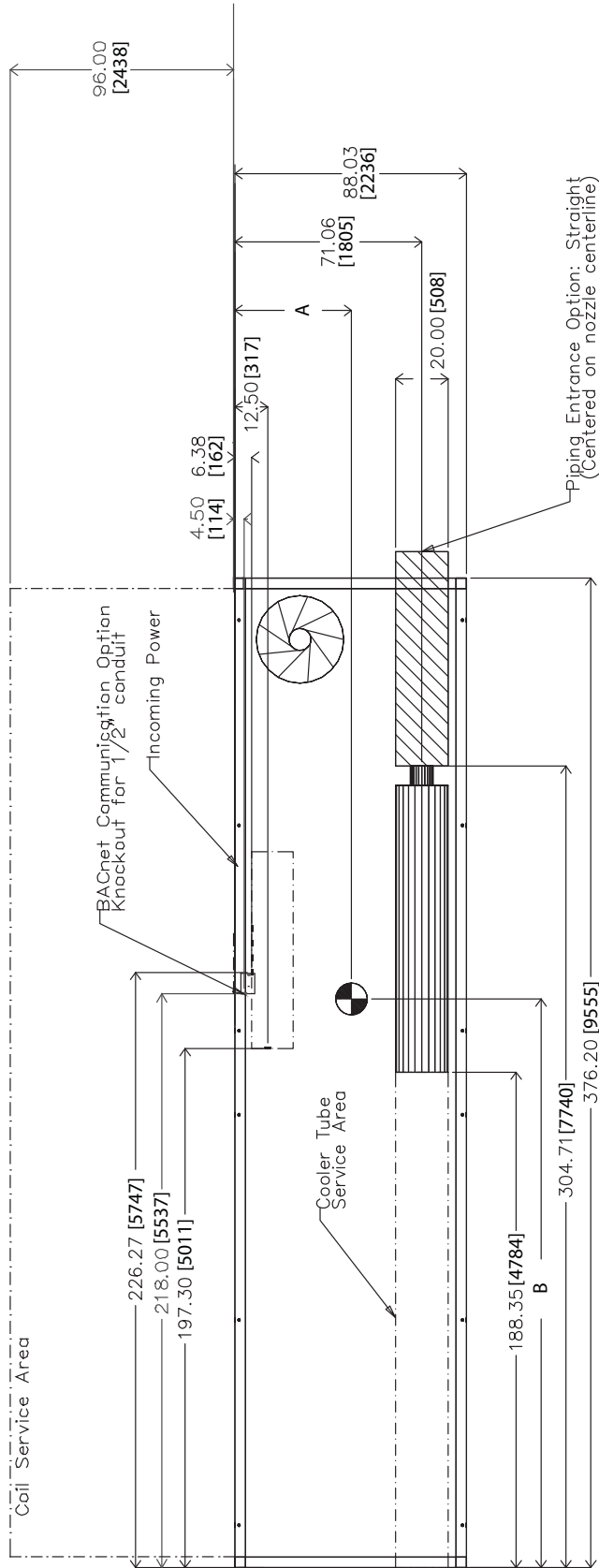

TOP VIEW

30XA260,280,300 (cont)

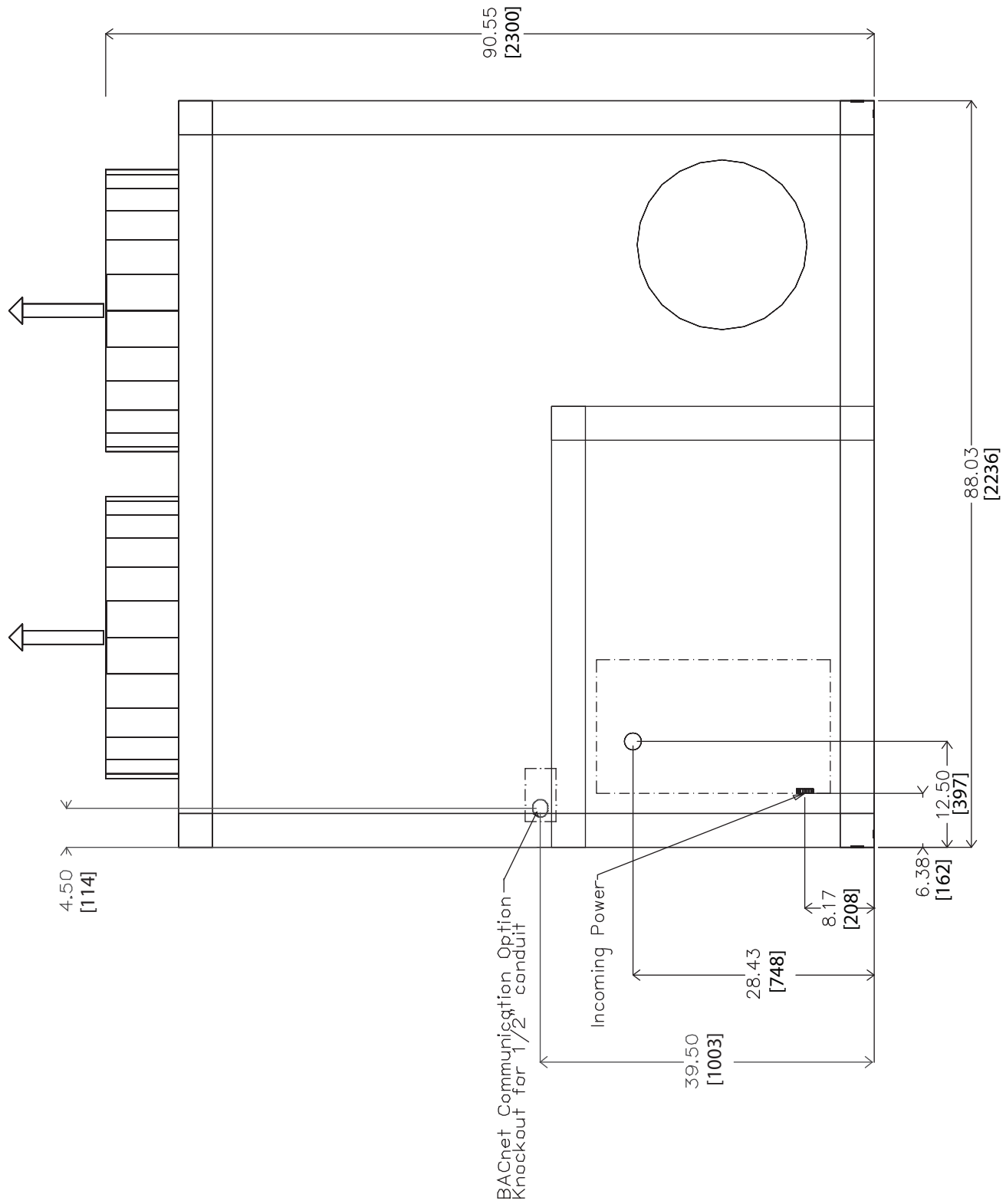

30XA260,280,300 (cont)

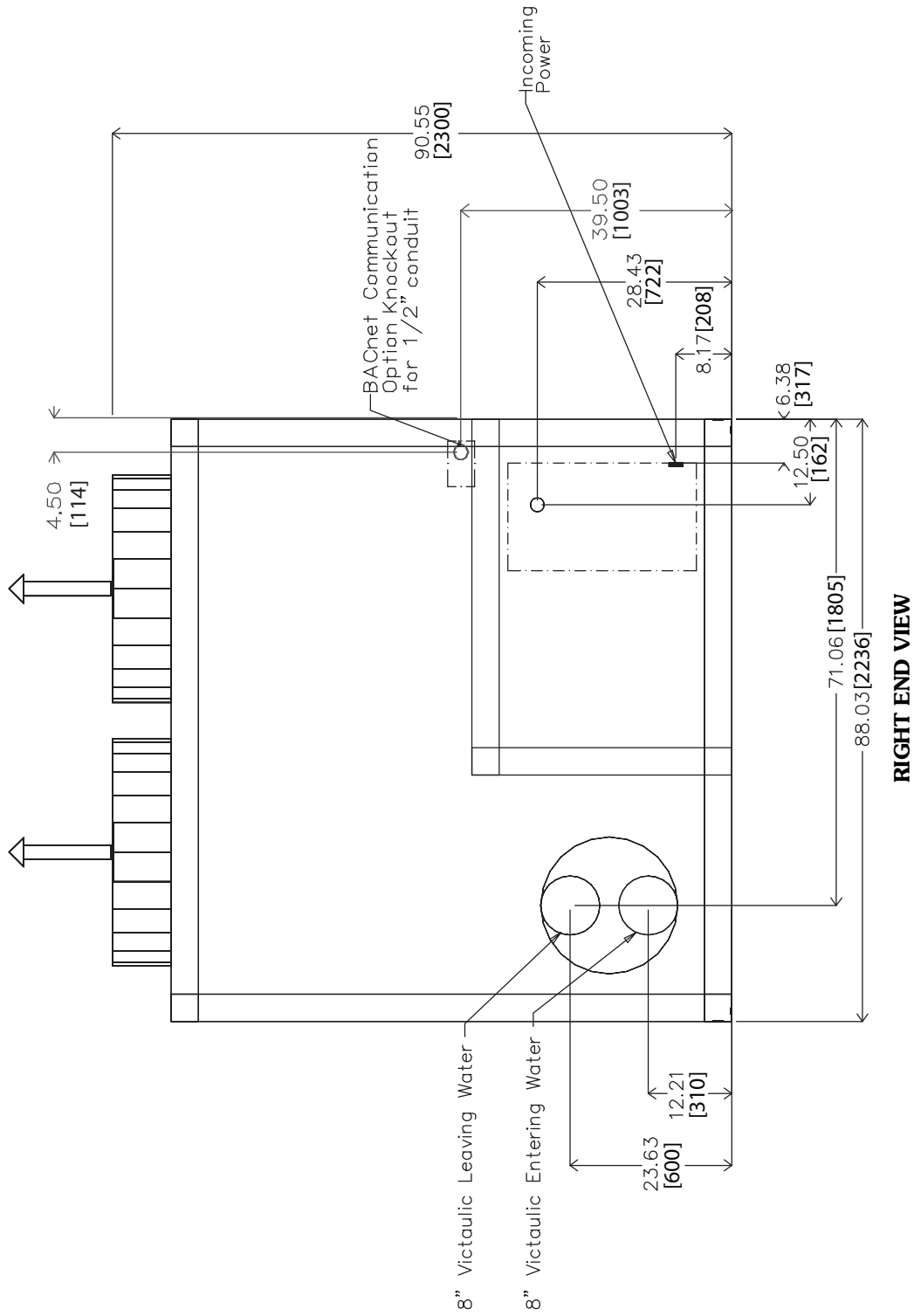

RIGHT END VIEW

30XA260,280,300 (cont)

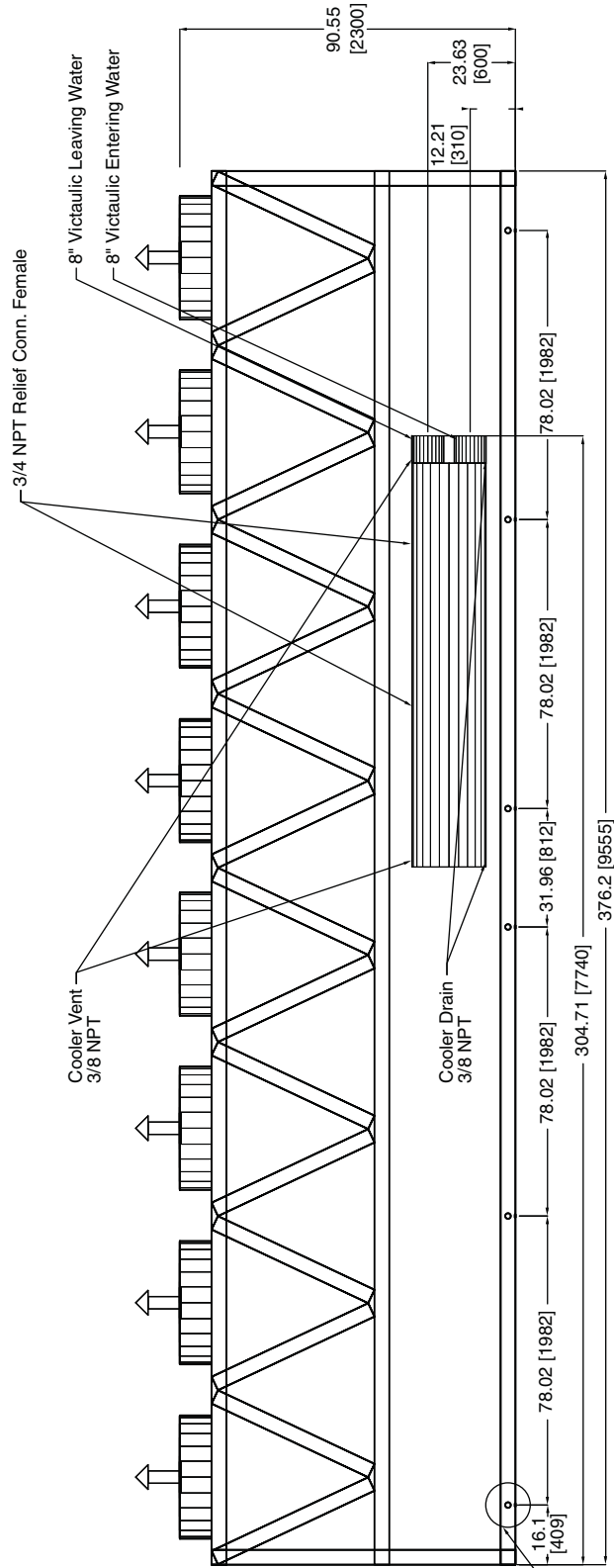
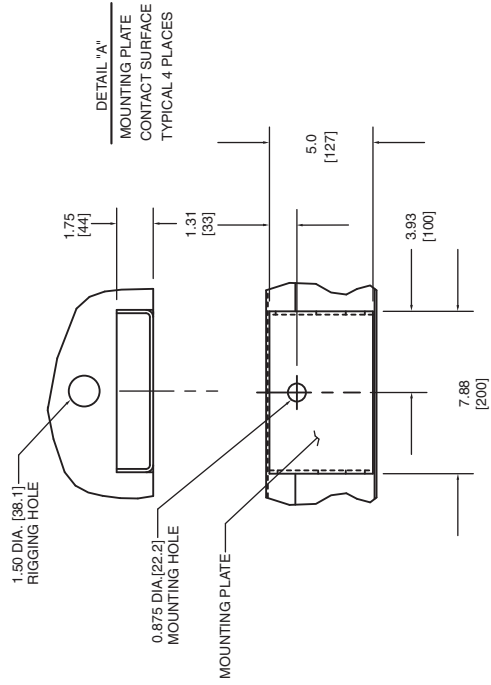

Mounting Holes
Rigging Holes
(See Detail A)

FRONT VIEW

30XA260,280,300 (cont)

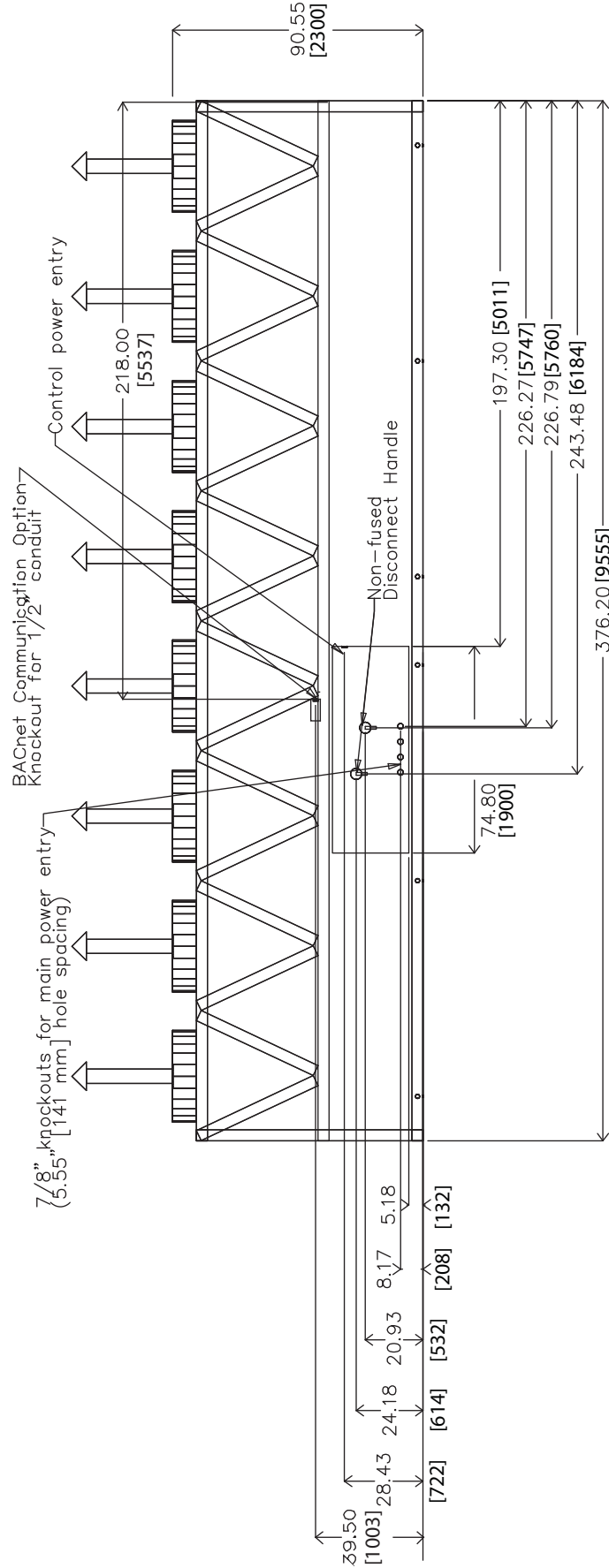

BACK VIEW

30XA262,282 (DX COOLER)

30XA UNIT	CGx	CGy
262	160.10 [4067]	44.22 [1123]
282	160.40 [4074]	44.30 [1125]

NOTES:

- Unit must have clearances as follows:
 - Top — Do not restrict
 - Sides and end — 6 ft (1.8 m) from solid surface
 - Airflow side — 8 ft (2.4 m) required for coil service area
- Temperature relief devices are located on liquid line and economizer assemblies and have 1/4-in. flare connection.
- Pressure relief devices are located on the cooler (5/8-in. NPT male connector) and on each oil separator (3/8-in. flare connection).
- Dimensions are shown in inches. Dimensions in [] are in millimeters.

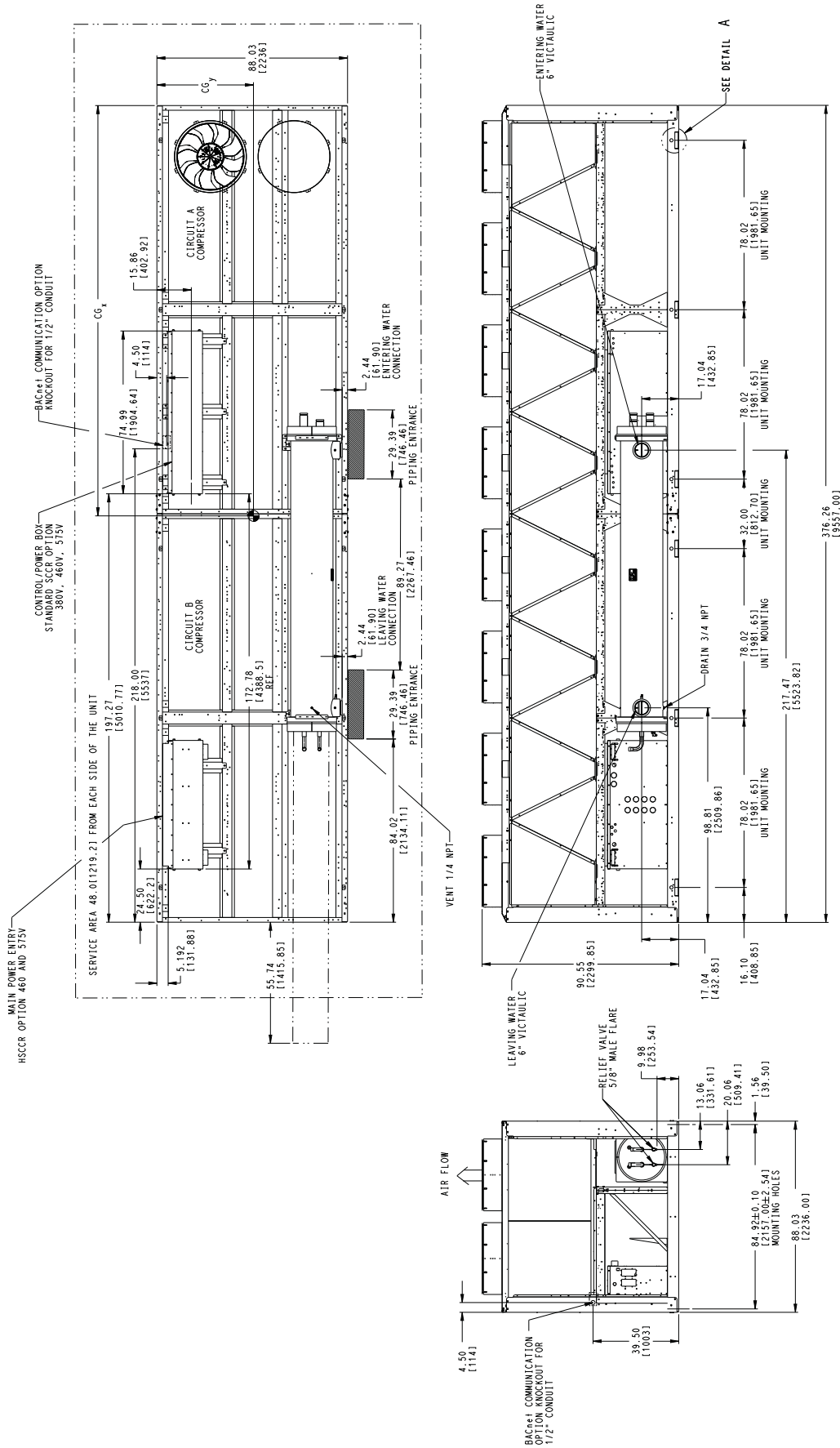

00DCN500005000A D

30XA262,282 (DX COOLER) (cont)

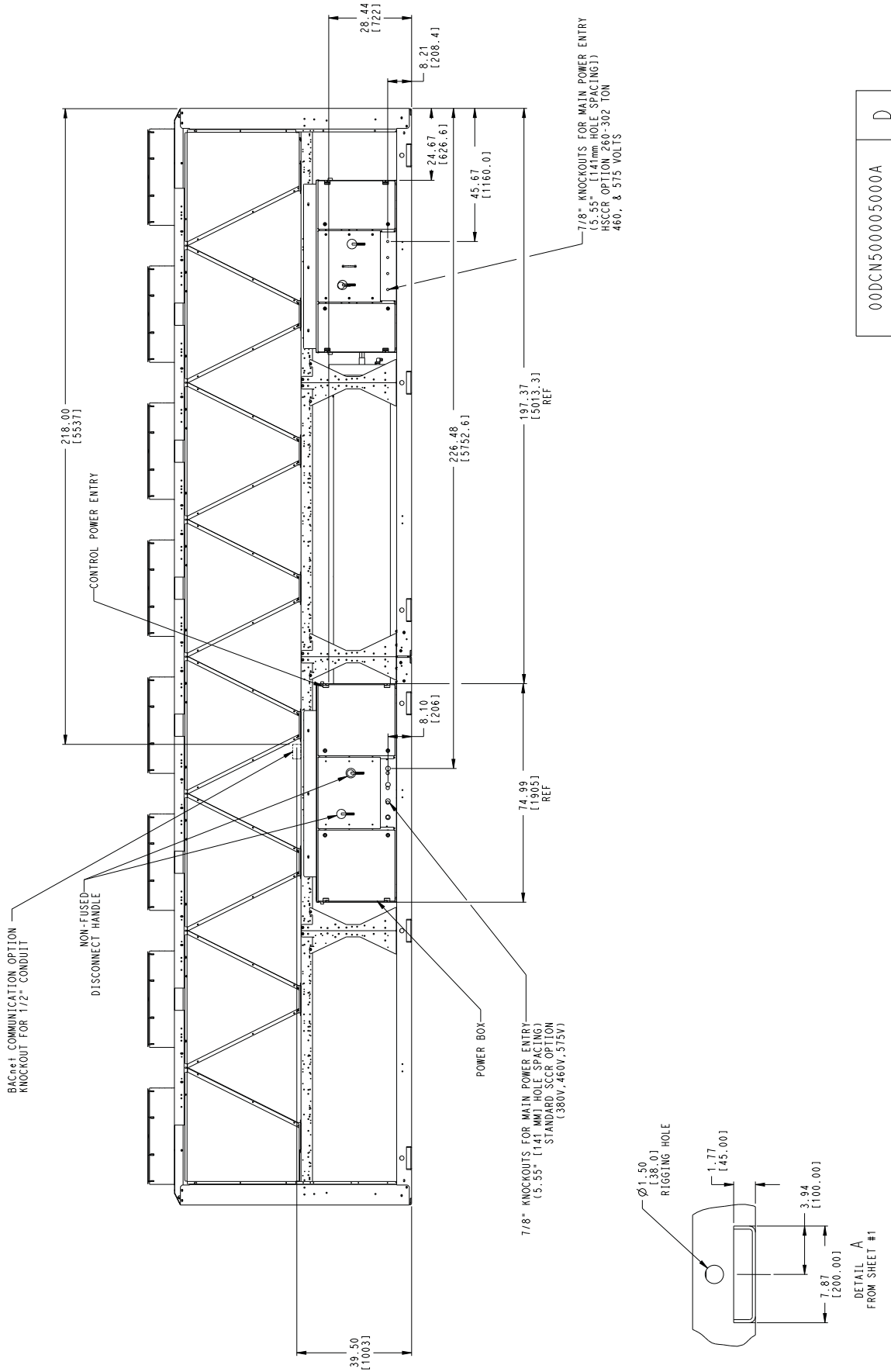

30XA302 (DX COOLER)

30XA UNIT	CGx	CGy
302	160.08 [4066]	44.32 [1126]

- NOTES:**
- Unit must have clearances as follows:
 Top — Do not restrict
 Sides and end — 6 ft (1.8 m) from solid surface
 Airflow side — 8 ft (2.4 m) required for coil service area
 2. Temperature relief devices are located on liquid line and economizer assemblies and have 1/4-in. flare connection.
 3. Pressure relief devices are located on the cooler (5/8-in. NPT male connector) and on each oil separator (3/8-in. flare connection).
 4. Dimensions are shown in inches. Dimensions in [] are in millimeters.

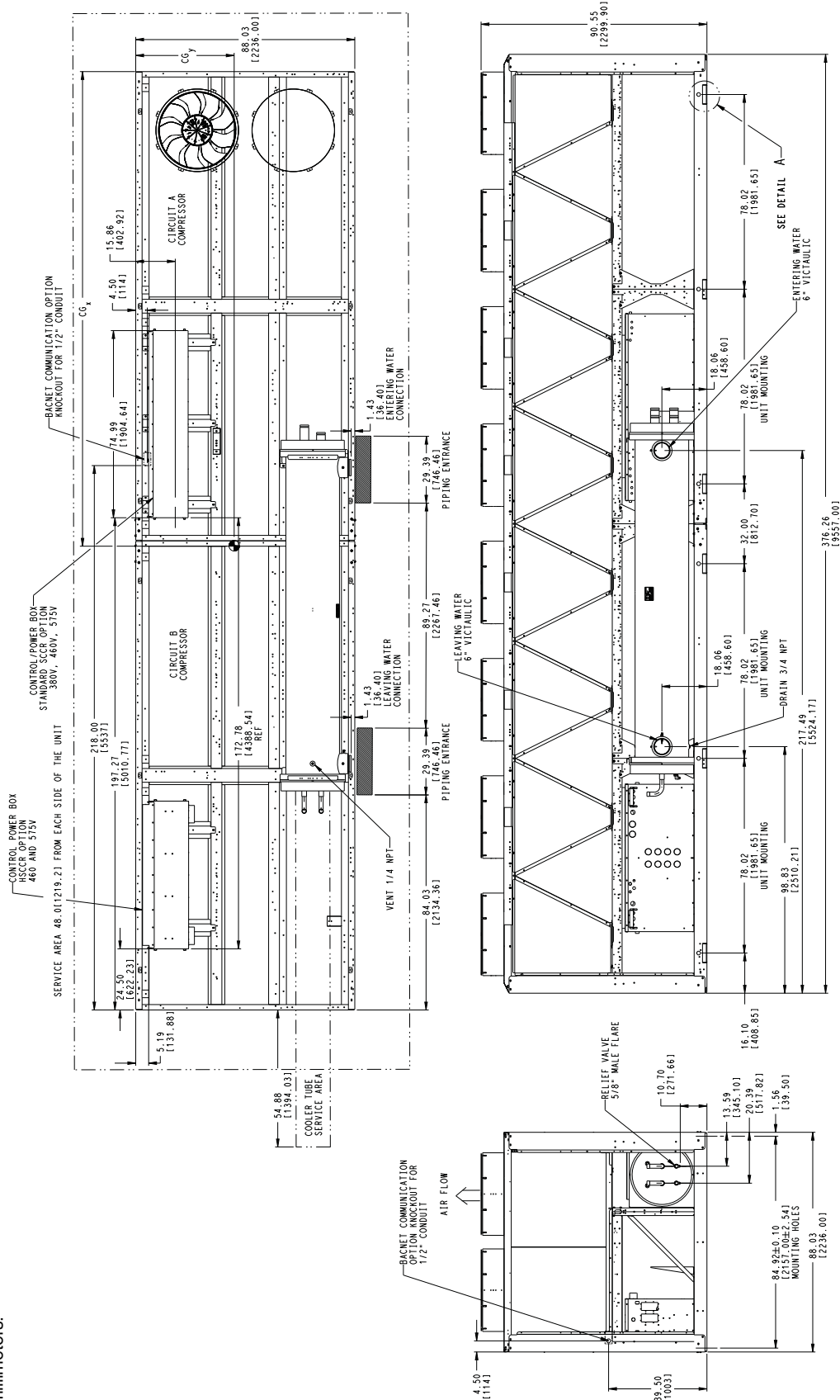

00DCN500005100A D

Dimensions (cont)

30XA302 (DX COOLER) (cont)

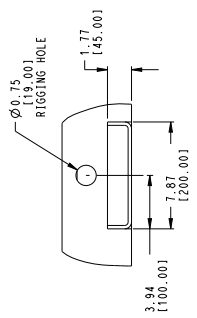
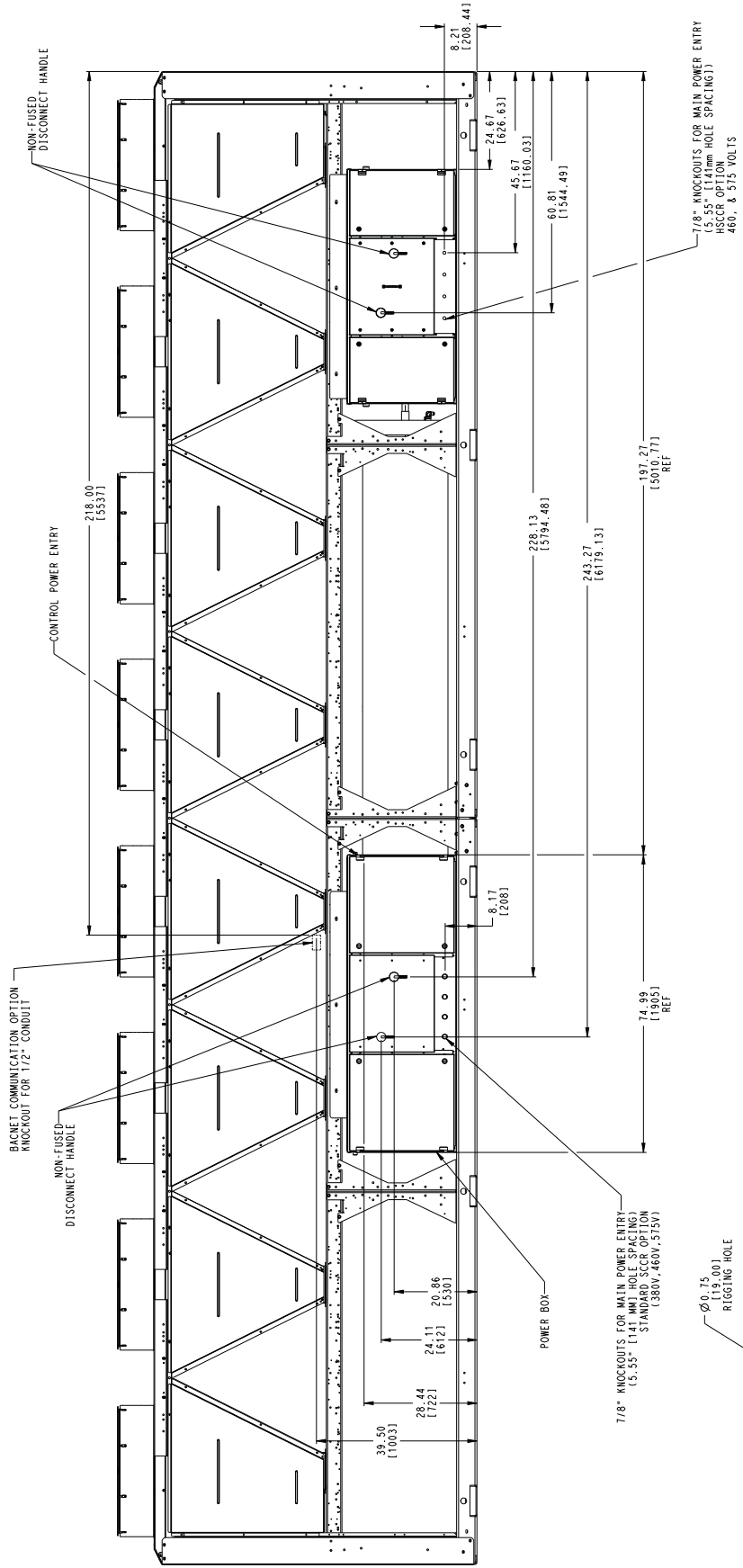

00DCN500005100A D

30XA325,350 (SEE NOTE 4)

NOTES:

1. Unit must have clearances as follows:
 Top — Do not restrict
 Sides and Ends — 6 ft (1.8 m) from solid surface.
2. Temperature relief devices are located on liquid line and economizer assemblies and have 1/4-in. flare connection.
3. 3/8-in. NPT vents and drains located in each cooler head at each end of cooler.
4. Drawing depicts unit with single point power, standard two-pass cooler, and standard SCCR (short circuit current rating). Refer to the Packaged Chiller Builder program for other configurations.
5. Dimensions are shown in inches. Dimensions in [] are in millimeters.

30XA UNIT	A	B
325	42.92 [1090]	246.16 [6252]
350	42.92 [1090]	246.72 [6267]

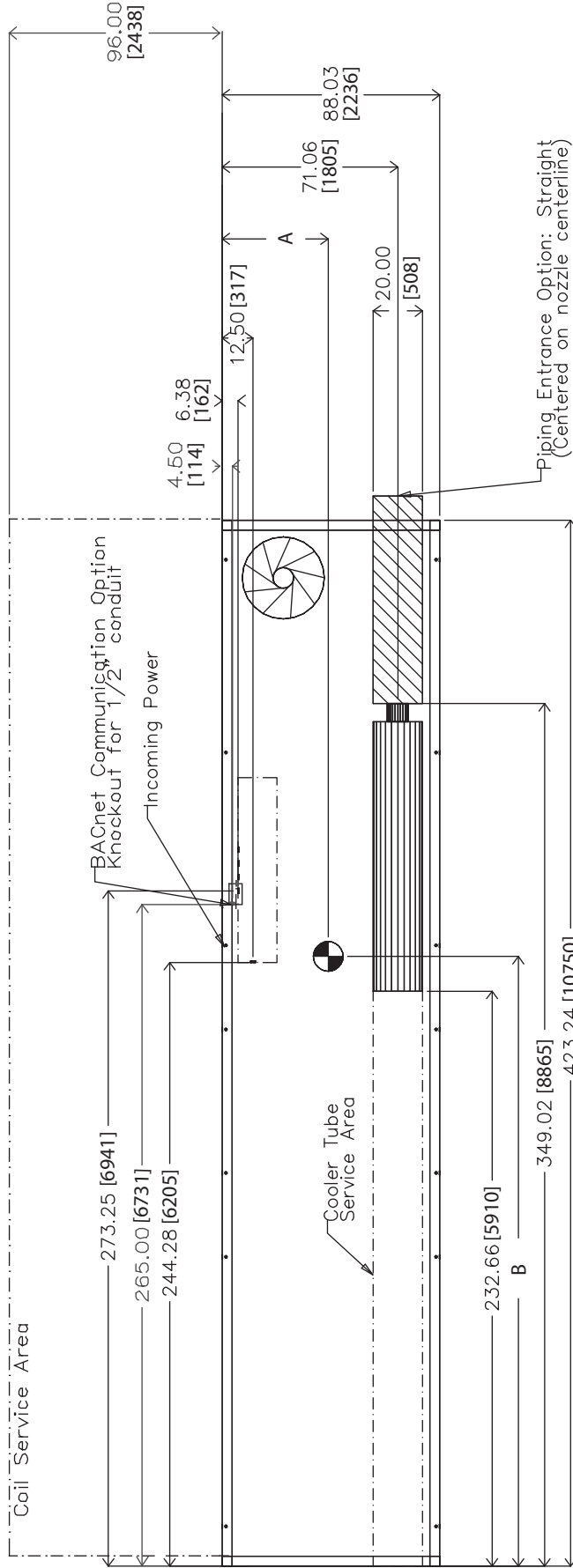

TOP VIEW

Dimensions (cont)

30XA325, 350 (cont)

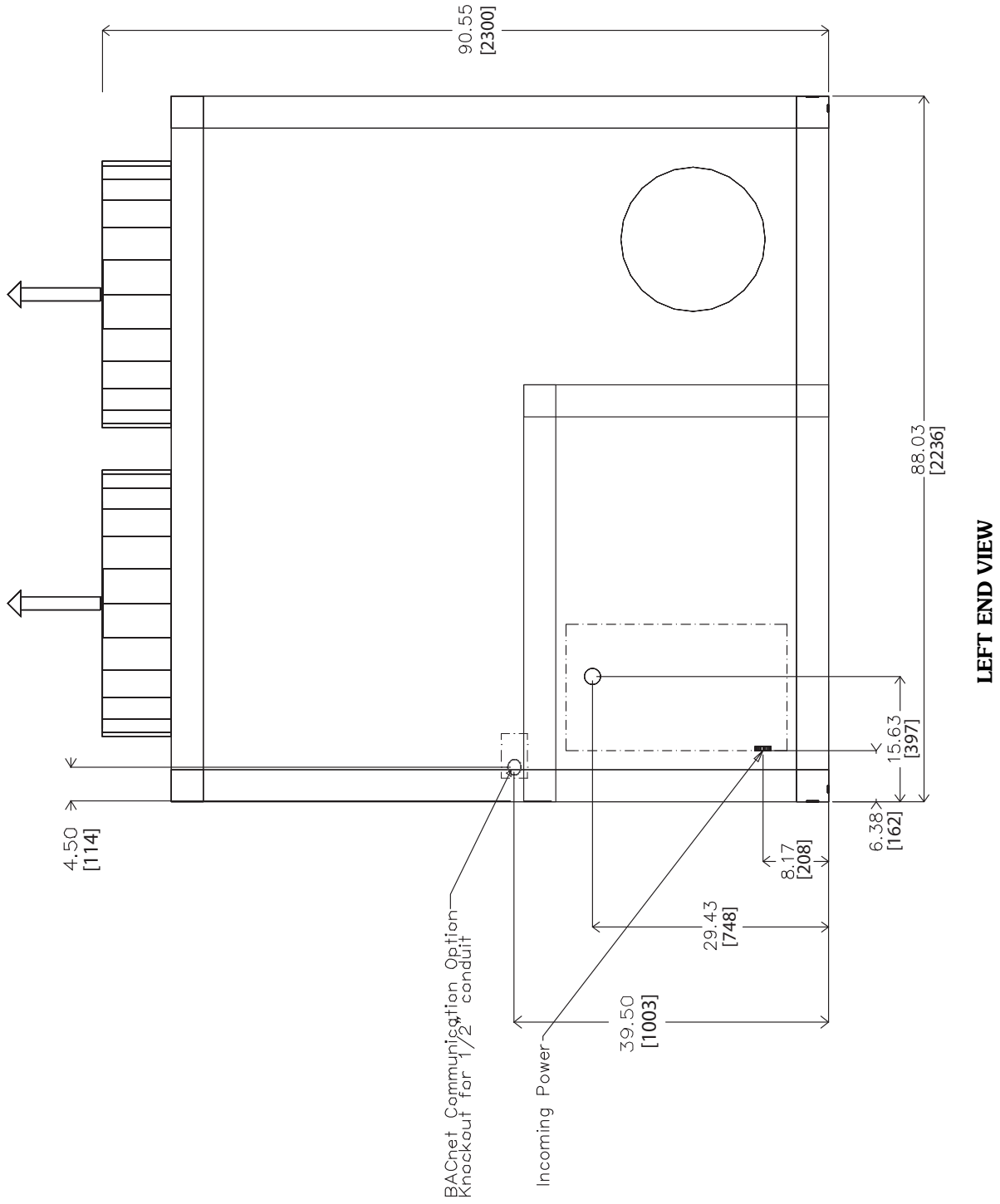

30XA325, 350 (cont)

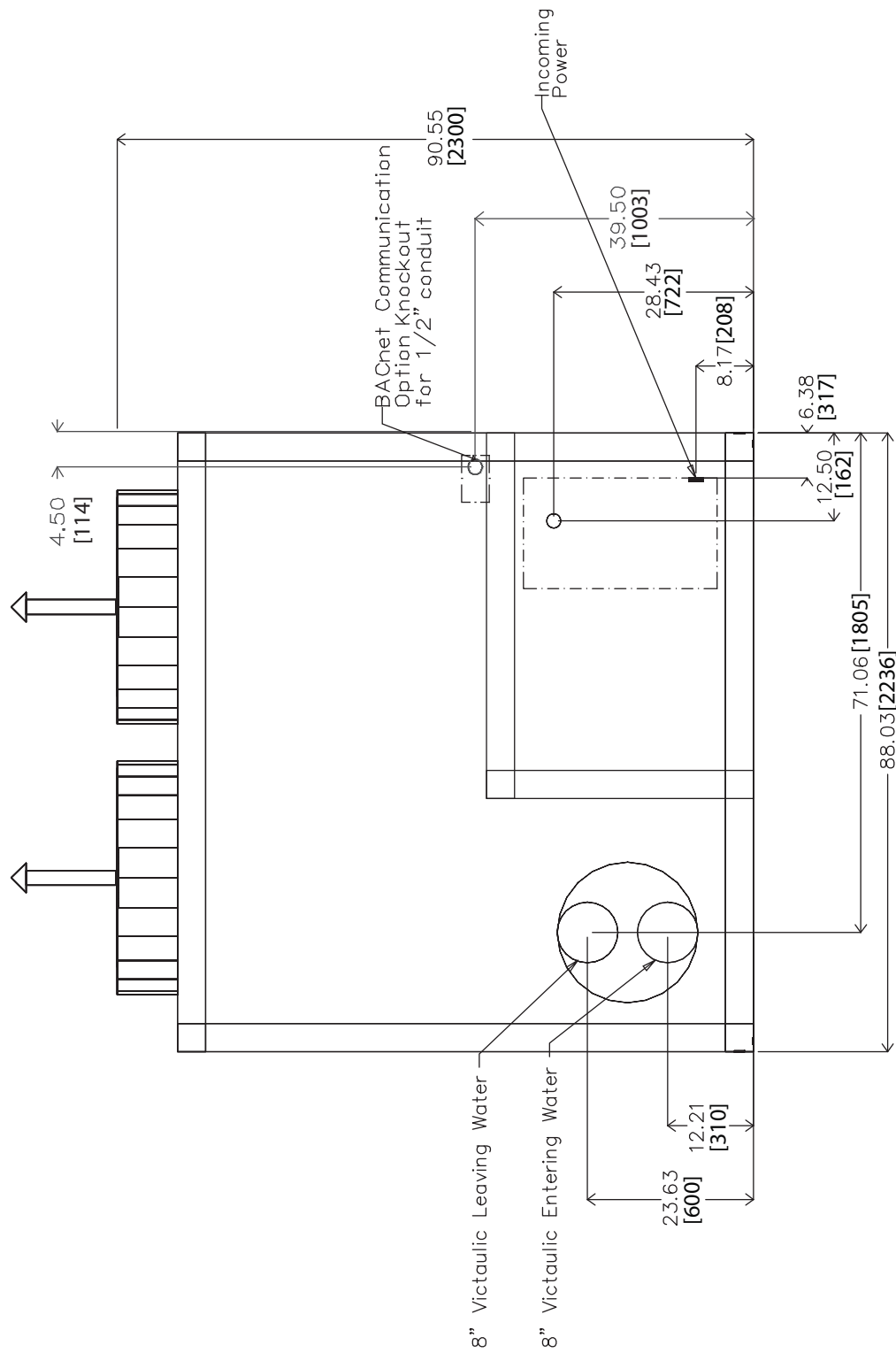

RIGHT END VIEW

30XA325,350 (cont)

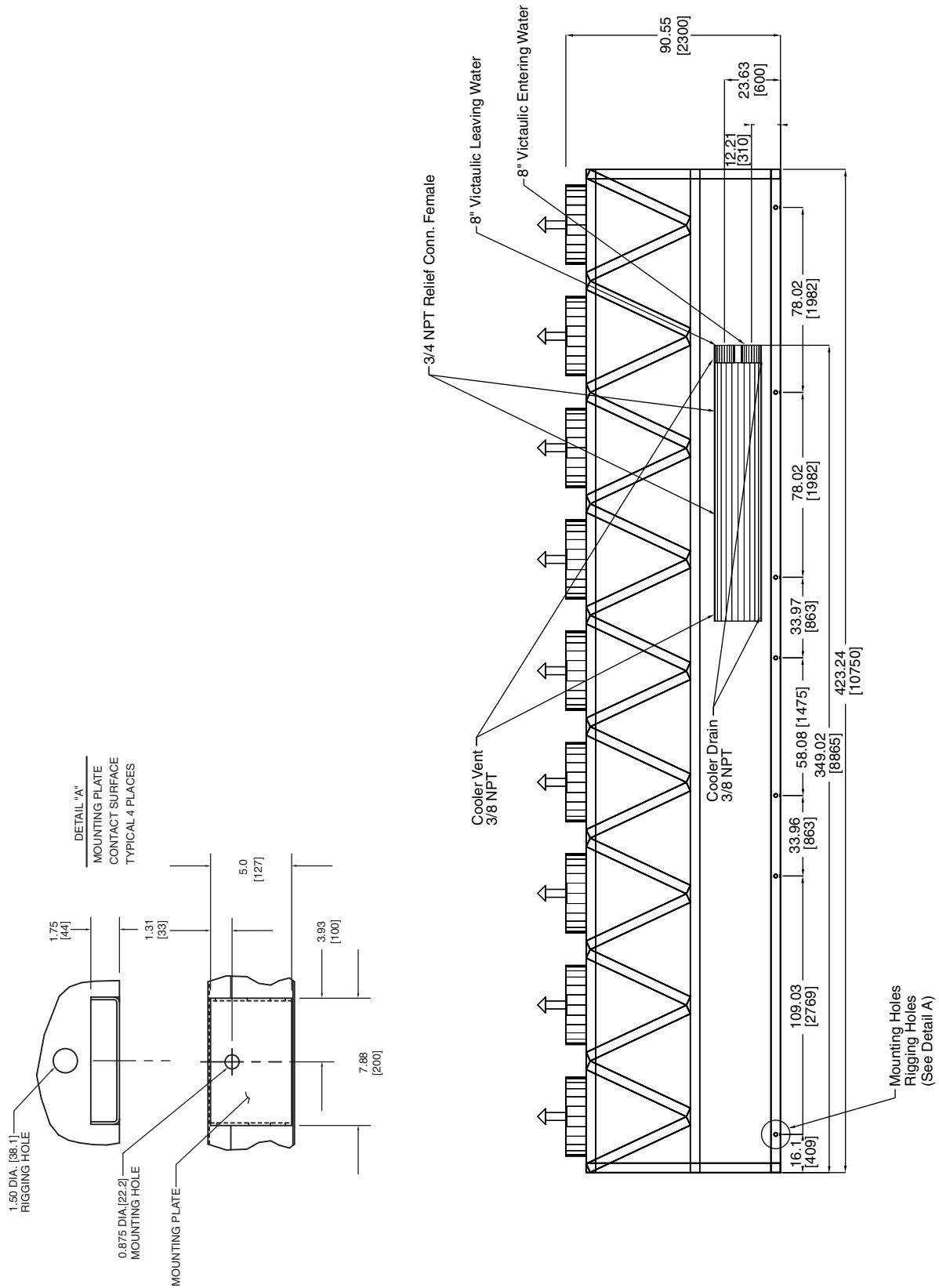

30XA325,350 (cont)

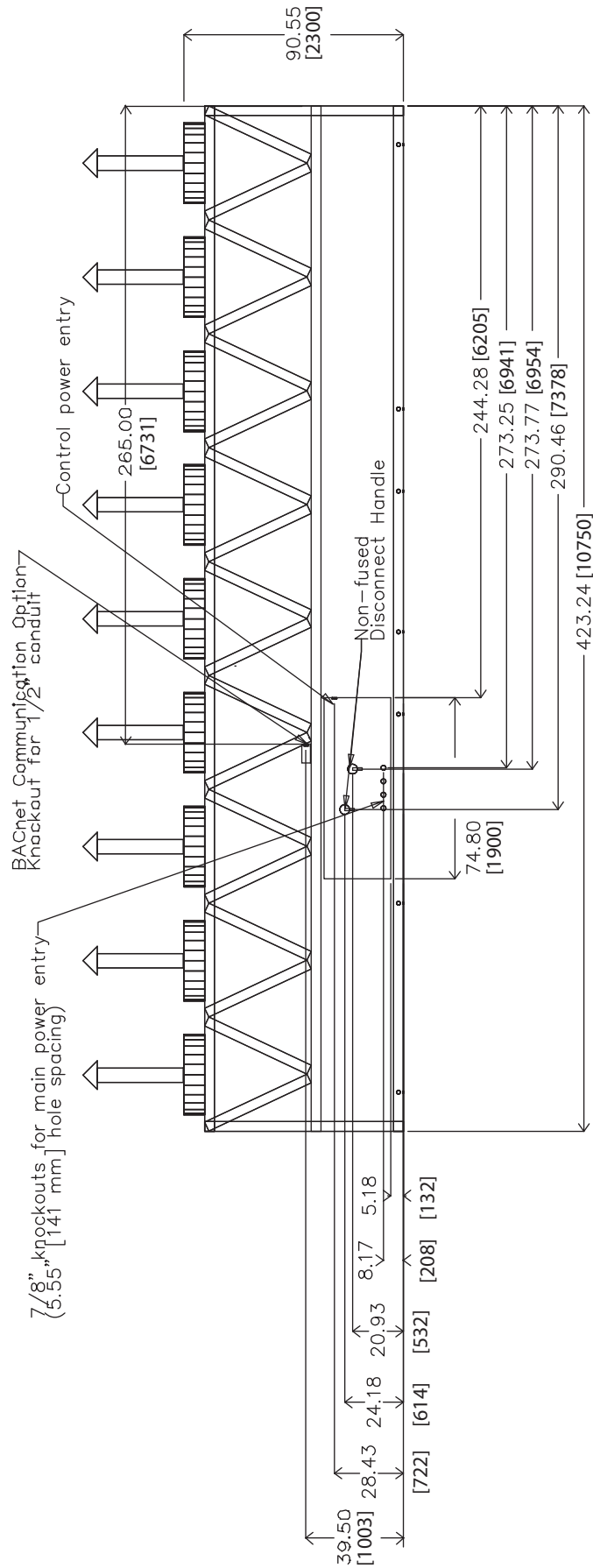

BACK VIEW

30XA327,352 (DX COOLER)

30XA UNIT	CGx	CGy
327	177.11 [4499]	42.92 [1090]
352	165.55 [4484]	42.92 [1090]

- NOTES:**
- Unit must have clearances as follows:
 Top — Do not restrict
 Sides and end — 6 ft (1.8 m) from solid surface
 Airflow side — 8 ft (2.4 m) required for coil surface area.
 - Temperature relief devices are located on liquid line and economizer assemblies and have 1/4-in. flare connection.
 - Pressure relief devices are located on the cooler arator (5/8-in. NPT male connector) and on each oil separator (3/8-in. flare connection).
 - Dimensions are shown in inches. Dimensions in [] are in millimeters.

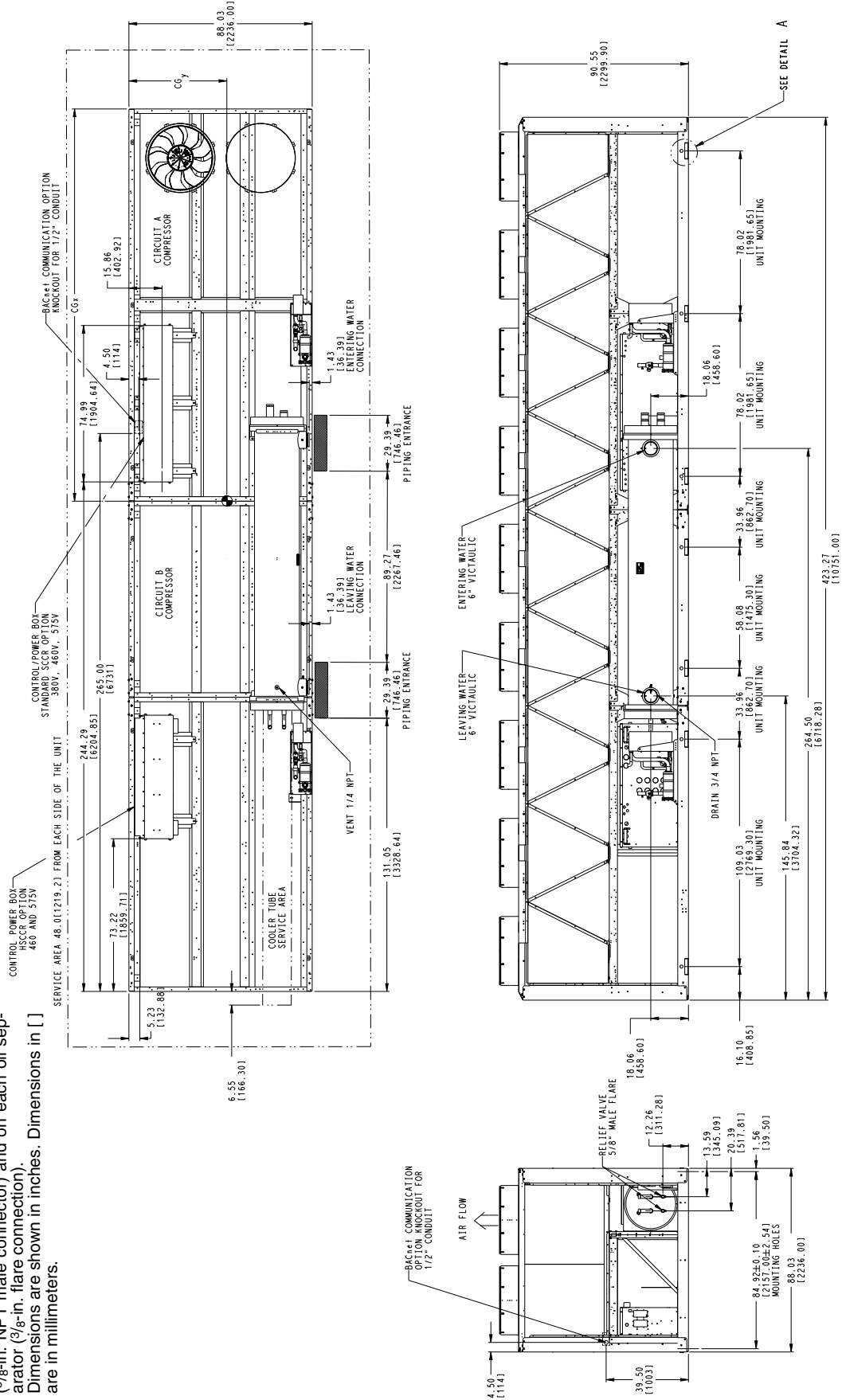

00DCN500005200A

D

30XA327,352 (DX COOLER) (cont)

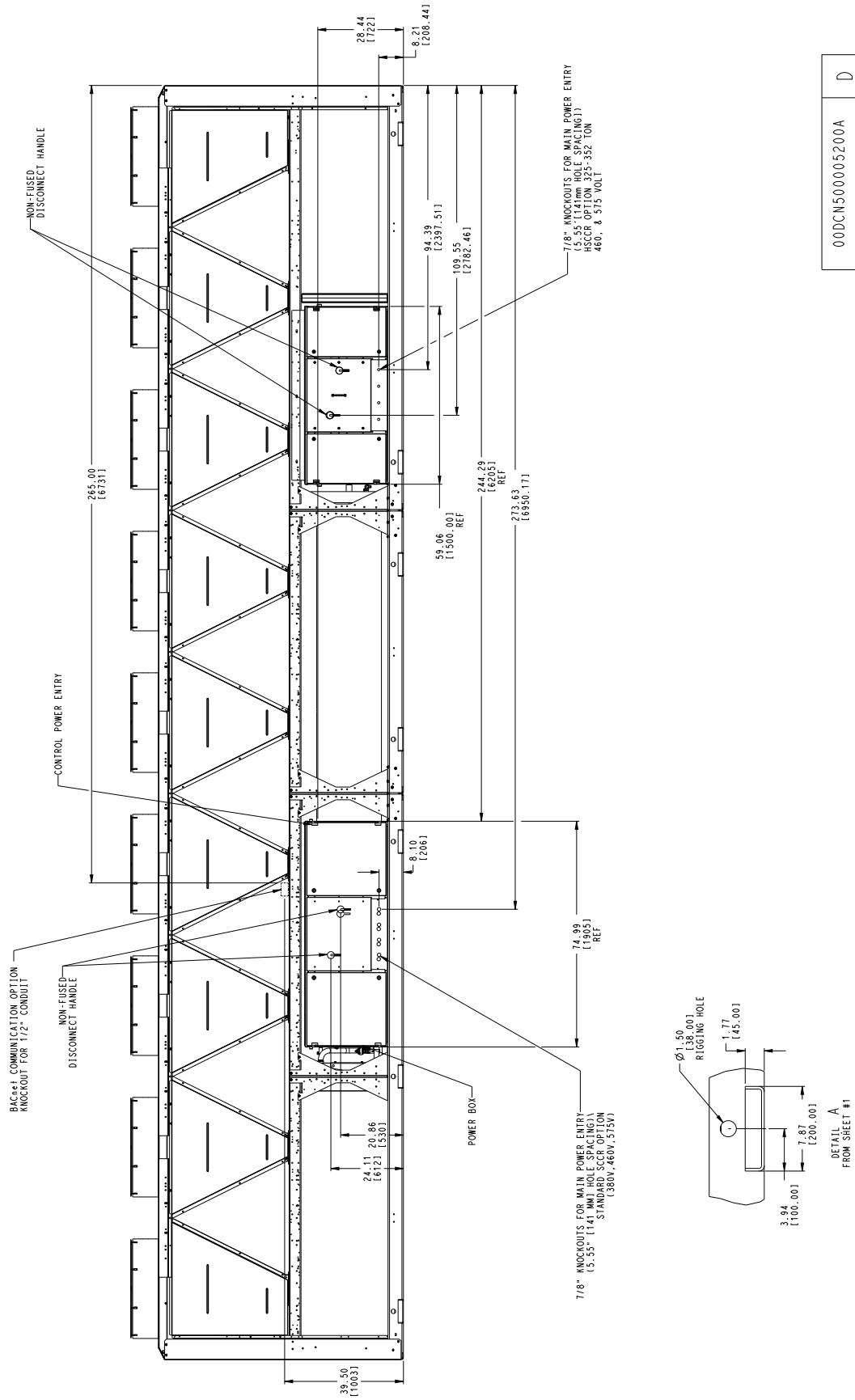

30XA401

NOTES:

- Unit must have clearances as follows:
 - Top — Do not restrict
 - Sides and End — 6 ft (1.8 m) from solid surface for airflow.
 - Side — 8 ft (2.4 m) required for coil service area.
- Temperature relief devices are located on liquid line and economizer assemblies and have 1/4-in. flare connection.
- Pressure relief devices are located on the cooler (3/4-in. NPT male connector) and on each oil separator (3/8-in. flare connector).
- 3/8-in. NPT vents and drains are located in each cooler head at each end of cooler.
- Dimensions are shown in inches. Dimensions in [] are in millimeters.

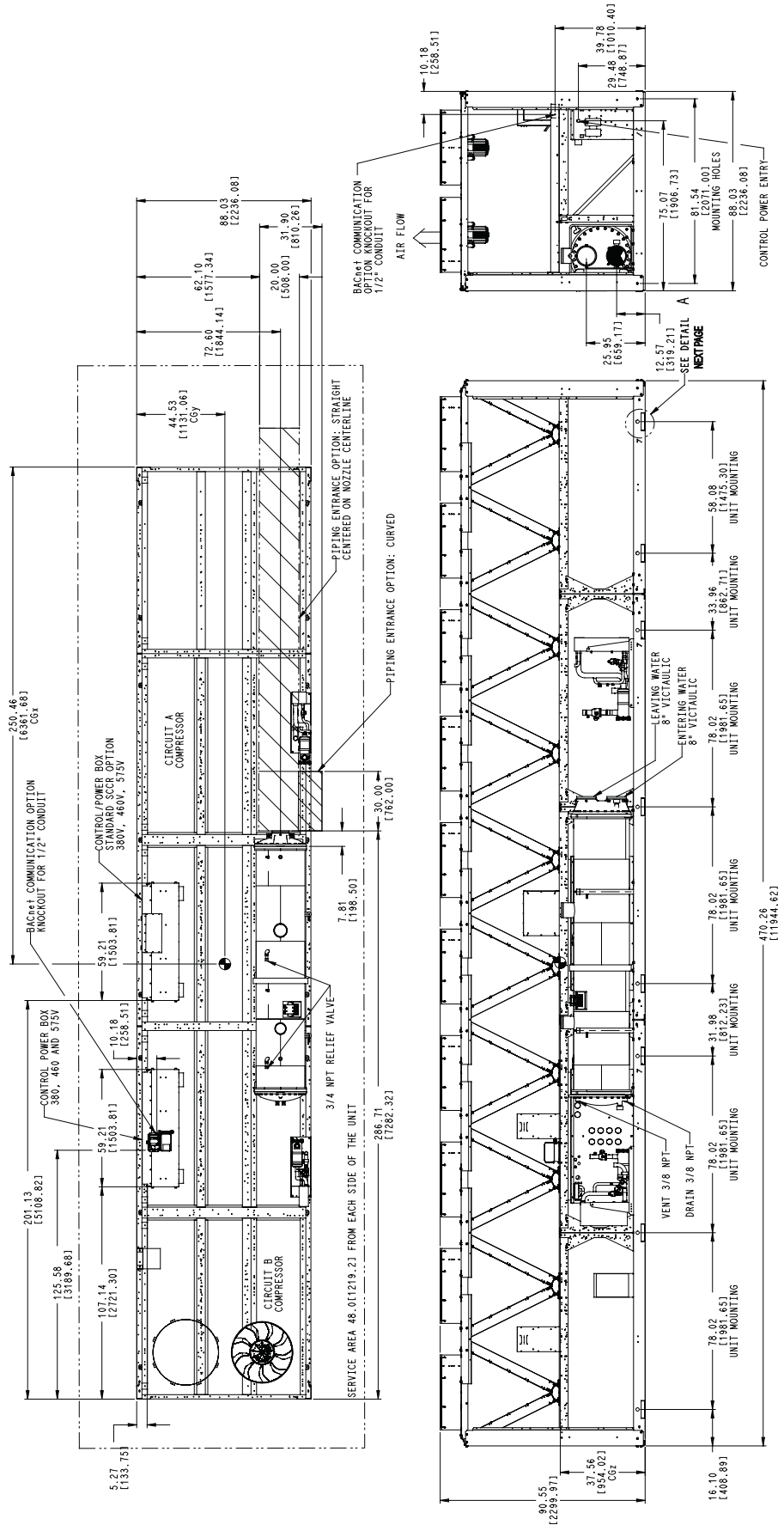

30XA401 (cont)

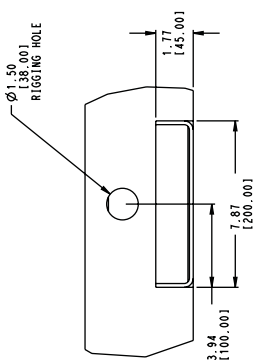
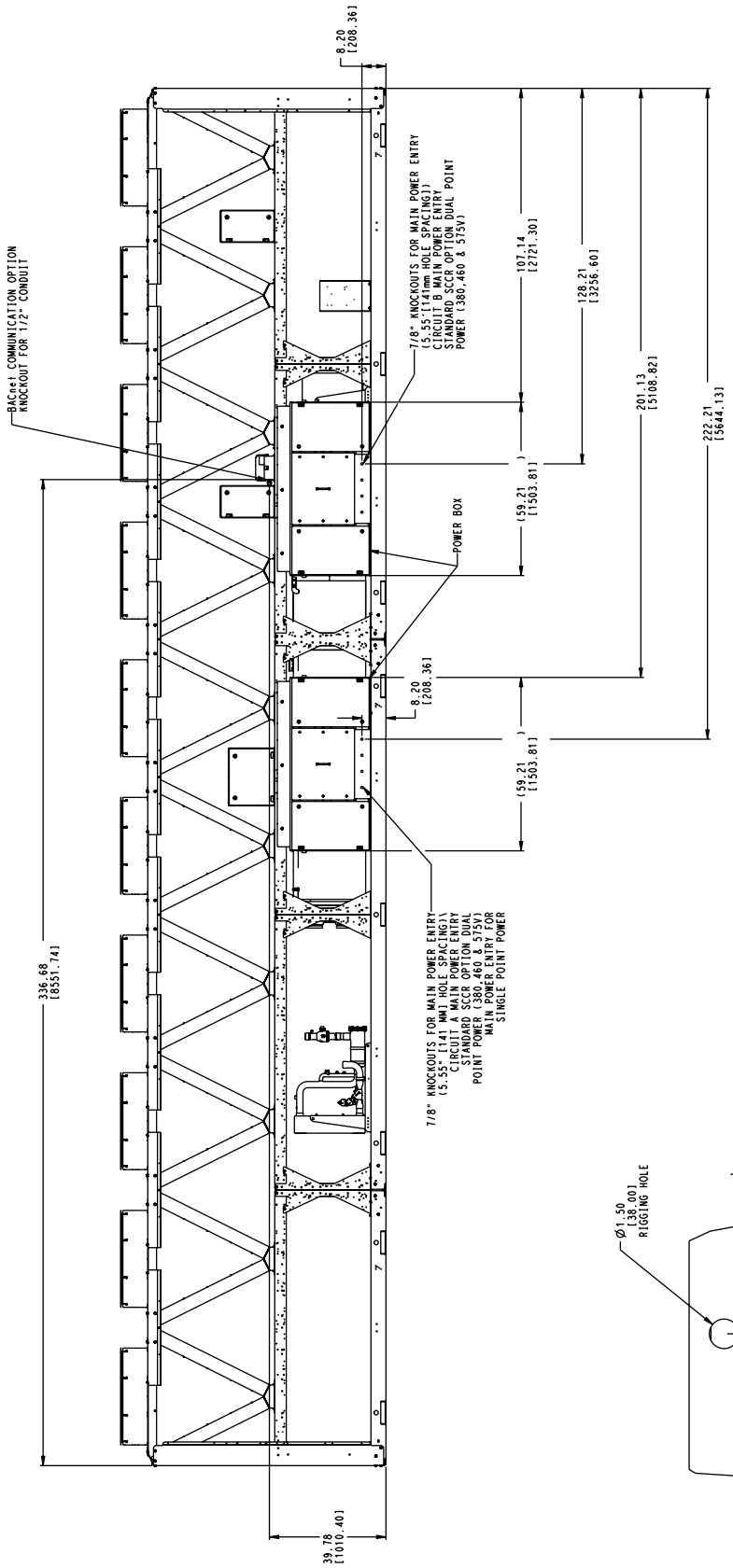

30XA451 (cont)

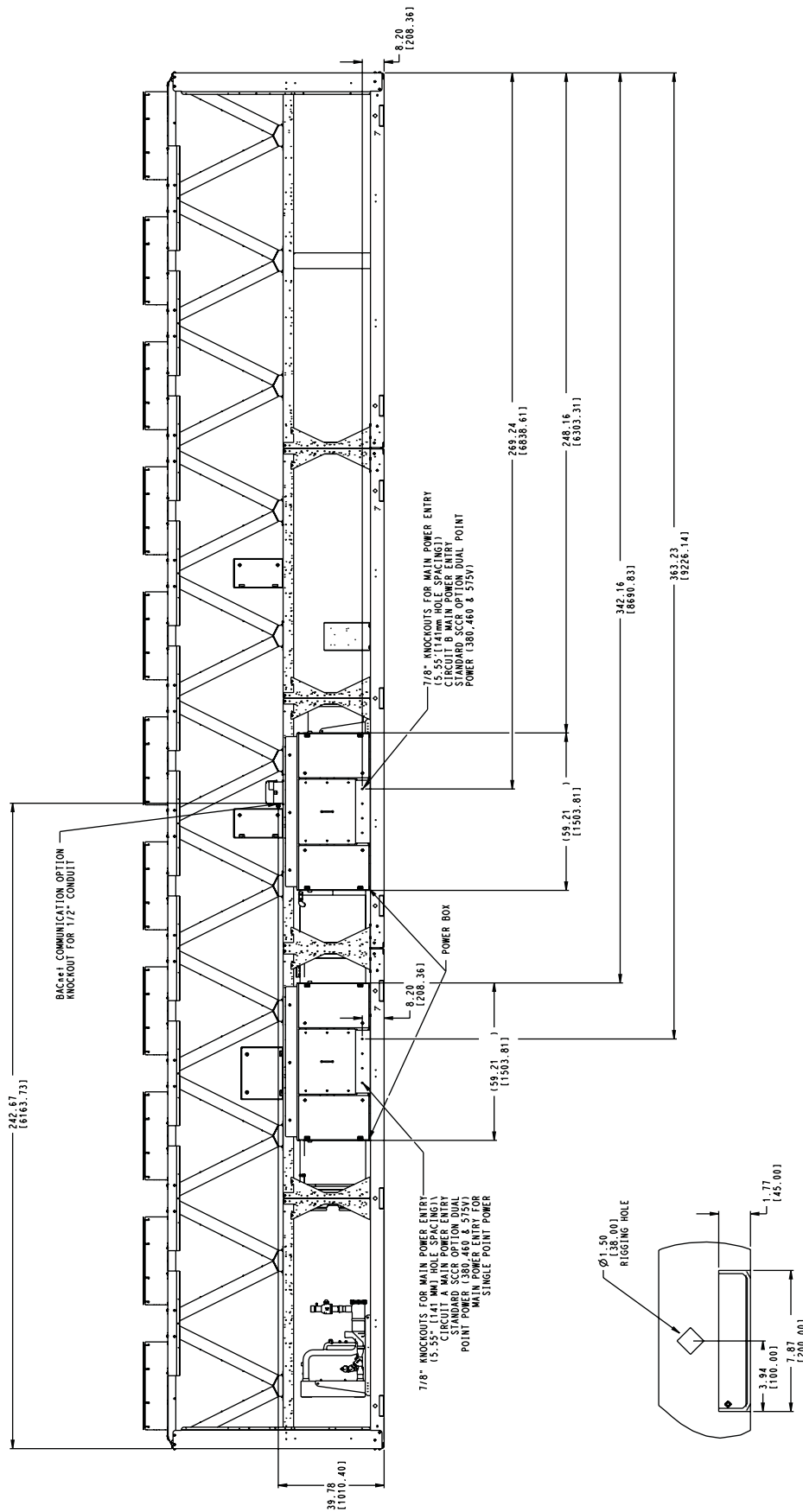

30XA476

NOTES:

- Unit must have clearances as follows:
 - Top — Do not restrict
 - Sides and End — 6 ft (1.8 m) from solid surface for coil service area.
 - Side — 8 ft (2.4 m) required for coil service area.
- Temperature relief devices are located on liquid line and economizer assemblies and have 1/4-in. flare connection.
- Pressure relief devices are located on the cooler (3/4-in. NPT male connector) and on each oil separator (3/8-in. flare connector).
- 3/8-in. NPT vents and drains are located in each cooler head at each end of cooler.
- Dimensions are shown in inches. Dimensions in [] are in millimeters.

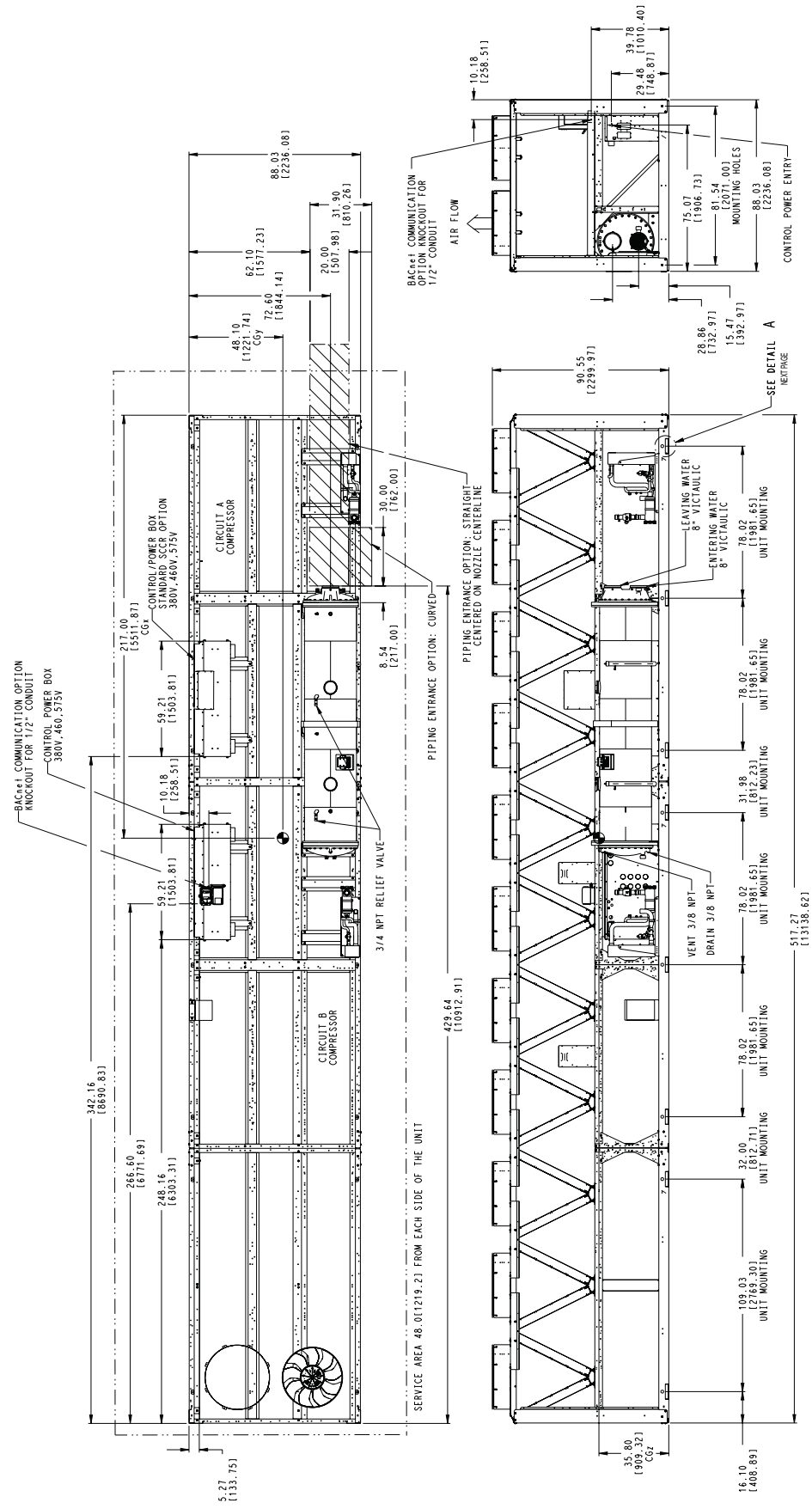

30XA476 (cont)

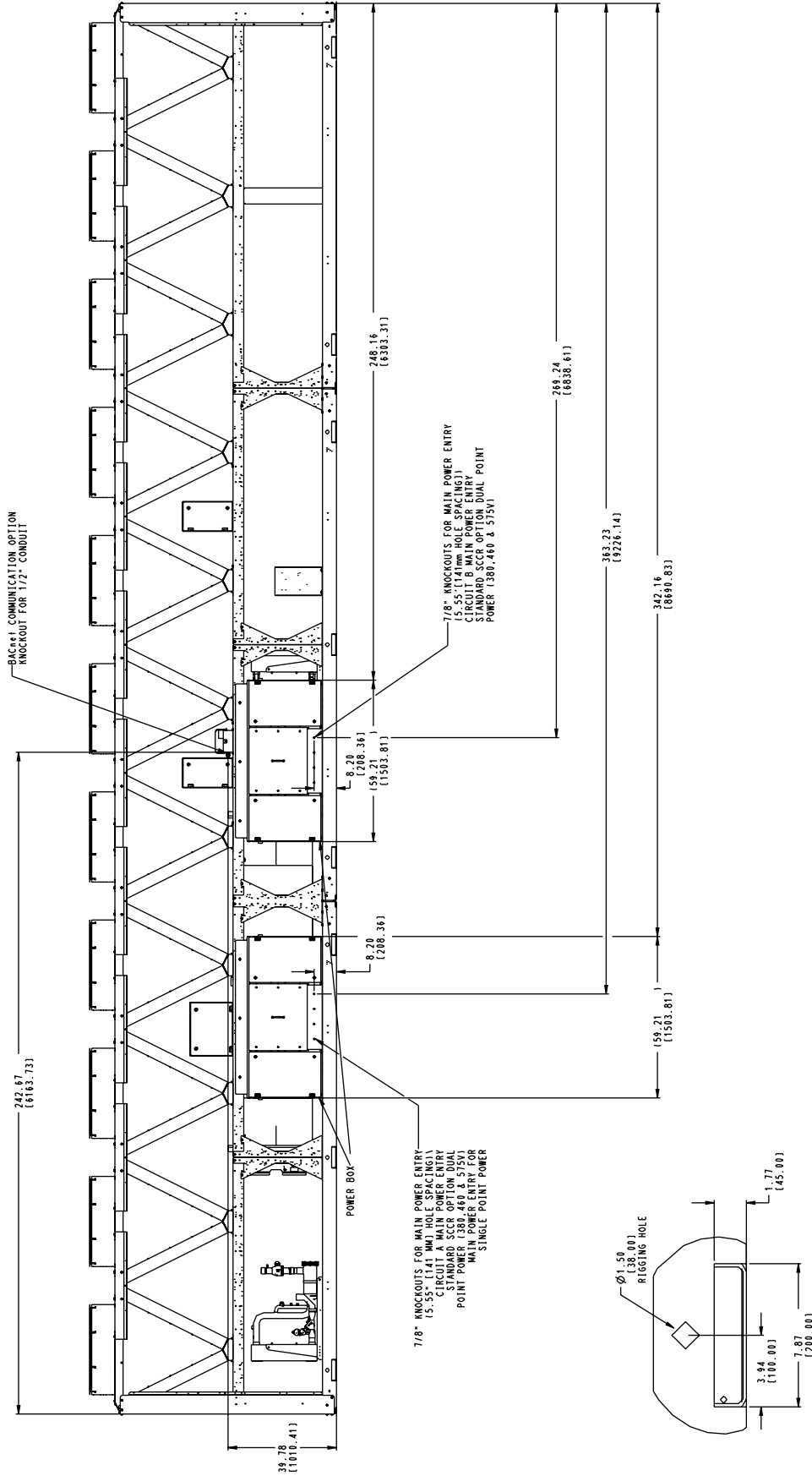

30XA501 (501A AND 501B MODULES)

NOTES:

- Unit must have clearances as follows:
 Top — Do not restrict
 Sides and End — 6 ft (1.8 m) from solid surface for airflow.
 Side — 8 ft (2.4 m) required for coil service area.
- Temperature relief devices are located on liquid line and economizer assemblies and have 1/4-in. flare connection.
- Pressure relief devices are located on the cooler (3/4-in. NPT male connector) and on each oil separator (3/8-in. flare connector).
- 3/8-in. NPT vents and drains are located in each cooler head at each end of cooler.
- 501A and 501B modules to be shipped separately.
- Dimensions are shown in inches. Dimensions in [] are in millimeters.

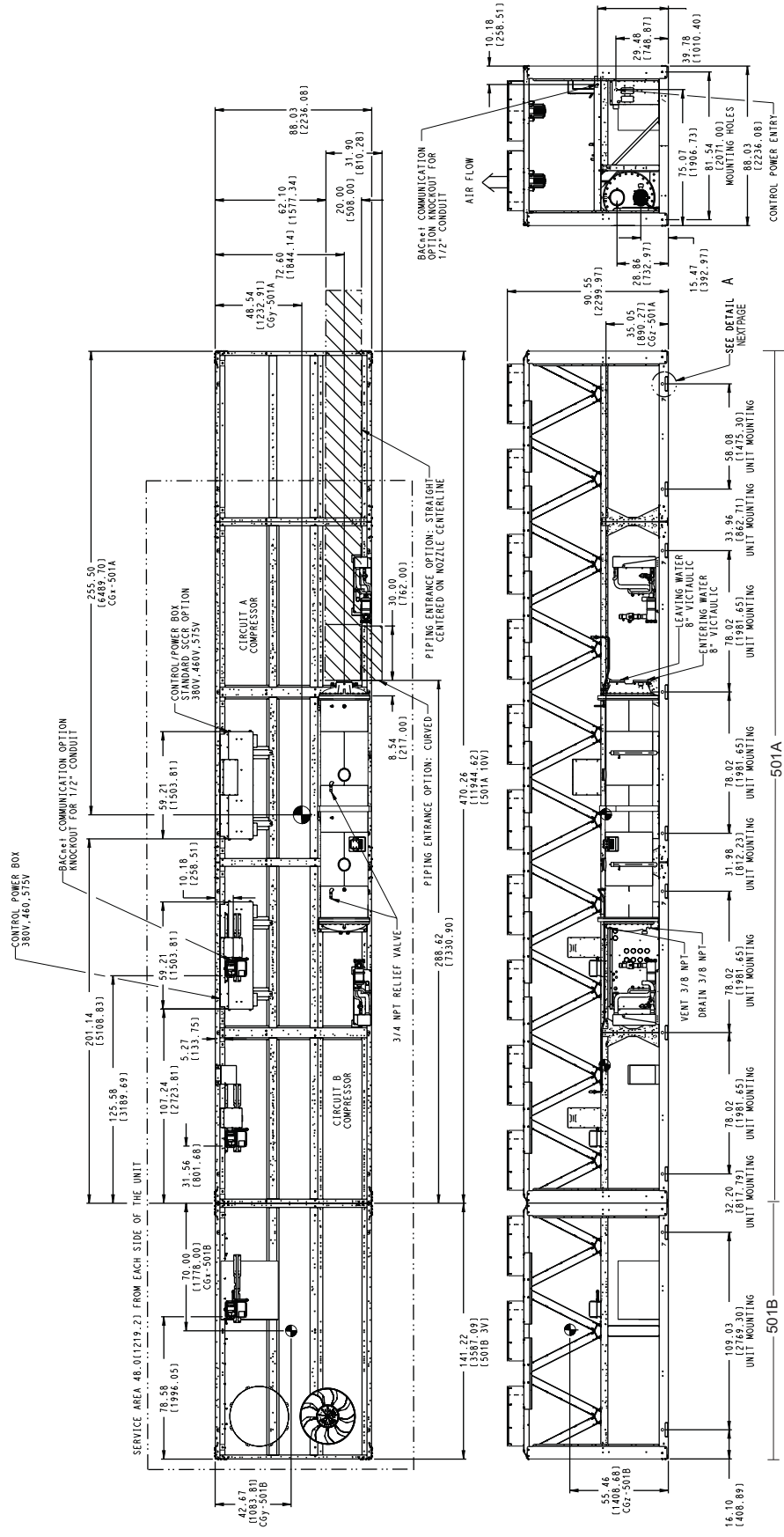

30XA501 (501A AND 501B MODULES) (cont)

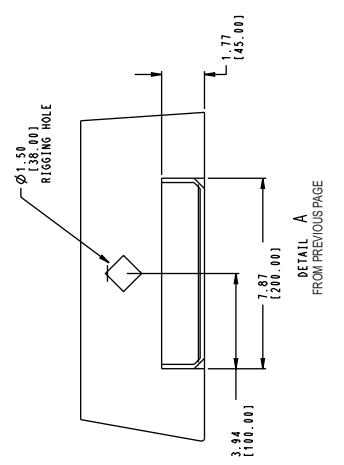
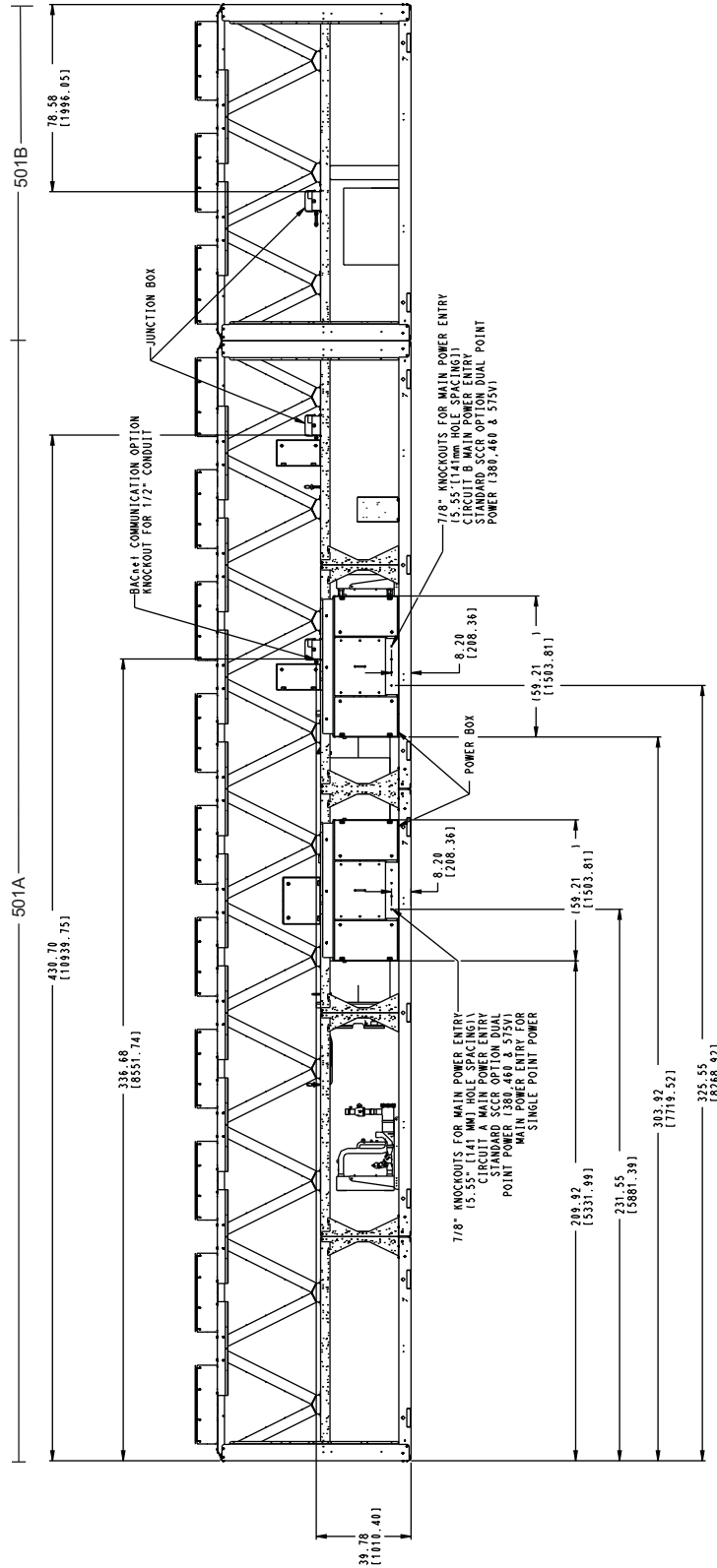

Selection procedure



Carrier's Packaged Chiller Builder Selection Program provides quick, easy selection of Carrier's air-cooled liquid chillers. The program considers specific temperature, fluid and flow requirements among other factors such as fouling and altitude corrections.

Before selecting a chiller, consider the following points:

Leaving water (fluid) temperature (LWT)

- If the LWT is less than 40°F (4.4°C), loop freeze protection to a minimum of 15°F (8.3°C) below the LWT set point is required. When the leaving fluid temperature is less than 30°F (-1.1°C), suction line insulation and low ambient head pressure control are required. In the flooded cooler case, a plus-one-pass cooler is also required. Consider the DX cooler option for these conditions.
- If the LWT requirement is greater than 60°F (15.5°C), a mixing loop is required.

Entering water temperature (EWT)

- If the EWT requirement is greater than 70°F (21.1°C), a mixing loop is required. The EWT should not exceed 70°F (21.1°C) for extended operation. Pulldown can be accomplished from 95°F (35°C).

Cooler flow rate or cooler delta-T:

- The cooler delta-T (EWT - LWT) must fall between 3 and 20°F (1.7 and 11.1°C) while still meeting both the fluid minimum/maximum temperature requirements as well as the fluid minimum/maximum flow requirements.
- For larger or smaller delta-T applications, a mixing loop is required.
- If the cooler flow is variable, the rate of change of flow should not exceed 10% per minute. A loop volume of greater than 3 gallons per ton (3.2 l/kW) is also recommended.

Cooler pressure drop:

- A high cooler pressure drop can be expected when the cooler delta-T is low. A mixing loop can help to alleviate this situation.
- Alternatively, consider a reduced pass option on flooded coolers when there is a low delta-T.
- A low cooler pressure drop can be expected when cooler delta-T is high.
- The plus-one-pass cooler option is recommended on flooded coolers to increase performance when cooler delta-T is high. This is particularly helpful with brine applications.

Water quality, fouling factor:

- Poor water quality can increase the required cooler fouling factor.
- Higher than standard fouling factors lead to lower capacity and higher input kW from a given chiller size compared to running the same application with better quality water (and lower fouling factors).

Operation below 32°F (0°C) ambient temperature:

- Low ambient temperature head pressure control is required.
- Wind baffles are required.

- Consider higher loop volumes, 6 to 10 gallons per nominal ton (6.5 to 10.8 l/kW).
- Loop freeze protection with glycol is strongly recommended to a minimum of 15°F (8.3°C) below lowest anticipated ambient temperature.
- Chilled water pump control is strongly recommended; otherwise override capability is required.

Chiller idle below 32°F (0°C) ambient temperature:

- Loop freeze protection with glycol is strongly recommended to a minimum of 15°F (8.3°C) below lowest anticipated ambient temperature.
- Chilled water pump control is strongly recommended; otherwise override capability is required.
- Drain the cooler — This will require a small amount of glycol for residual water. If cooler heaters are installed, the heaters will need to be disconnected.
- Consider using a remote cooler. Do not bury refrigerant piping.

Ambient temperature:

- Highest allowable ambient air temperature is 125.6°F (52°C) for all unit sizes other than 401-501 units. Highest allowable ambient air temperature is 131°F (55°C) for 401-501 units.

NOTE: The high ambient option is standard for 30XA401-501 units, and it is required for 30XA401-501 chillers that are either operating in multi-chiller configurations or have ambient temperatures at or above 100°F (37.8°C). Regardless of unit size, it may be necessary to select the high ambient option to obtain performance with ambient air temperatures approaching 125.6°F (52°C).

Cooling capacity requirement:

- Do not oversize the chillers by more than 15% at design conditions.
- If capacity control is required below the standard minimum step of unloading, the minimum load control option should be employed. (See selection program.)

Coil corrosion requirements:

- Coastal application
- Industrial application
- Coastal/industrial application
- Urban application
- Farming

NOTE: See NACO (North American Commercial Operations) Packaged Chiller Builder and appropriate selection guides for more information.

Temperature reset:

- Return water (standard)
- Outside air temperature (standard)
- Space temperature (accessory sensor required)
- 4 to 20 mA (requires an energy management module)

Demand limit:

- 2-step (requires an energy management module)
- 4 to 20 mA (requires an energy management module)
- CCN Loadshed

AquaForce® pump selection

Several pump sizes are available for each AquaForce chiller size to provide flexibility in matching water system requirements. A dual pump option is also available for primary/standby operation. The Carrier Packaged Chiller Builder Selection Program can be used (and is recommended) for pump selection, or selection can be done manually. Pump packages are available in both constant-speed and VFD configurations.

Proper water system design is critical; cooling loads, water pressure drops and proper water line sizing must be accounted for in order to ensure proper system operation. Incorrect or incomplete analysis/design of the water loop could lead to low water flow, loss of water temperature control, and excessive cycling of chiller compressors.

The following are the steps for manual selection of water pumps for the 30XA chillers (refer to Pump Curve Hydronic Package tables).

1. Calculate the water flow rate (gpm or l/s) and the total water (or brine) pressure drop of the system external to the 30XA chiller.
2. Use the pump envelope charts (page 90) to determine proper pump sizing. Plot water flow rate and total head point on the chart. The next pump curve above this point corresponds to the correct pump.

NOTE: Although pump bhp (brake horsepower) increases with glycol concentration, pumps and pump overloads are selected such that glycol concentrations up to 50% will not trip pump overloads if run within the recommended gpm ranges.

Example: Required water flow rate for a 30XA090 chiller is 200 gpm (12.6 l/s). The pressure drop for the water system external to the chiller is 60 ft (179.4 kPa). The dual pump is needed. Select the pump.

After examining the dual pump charts for the 30XA090 and using the indicated flow rate and external pressure drop, select pump 8.

PUMP IMPELLER SIZES

30XA UNIT SIZE	PUMP Hp	SINGLE PUMP				DUAL PUMP			
		Option Code*	Rpm	Impeller Dia. (in.)	Pump Curve	Option Code*	Rpm	Impeller Dia. (in.)	Pump Curve
090-162	5	1,G	3450	4.5	I	7,N	3450	4.5	II
	7.5	2,H	3450	5.0	I	8,P	3450	5.0	II
	10	3,J	3450	5.4	I	B,Q	3450	5.4	II
	15	4,K	3450	6.1	I	C,R	3450	6.1	II

*Option Code refers to the Hydronics Option (position 11) in the model number. See Model Number Nomenclature on page 4 for option identification.

SINGLE PUMP ENVELOPE CURVES (30XA090-162)

30XA090,092,100,102

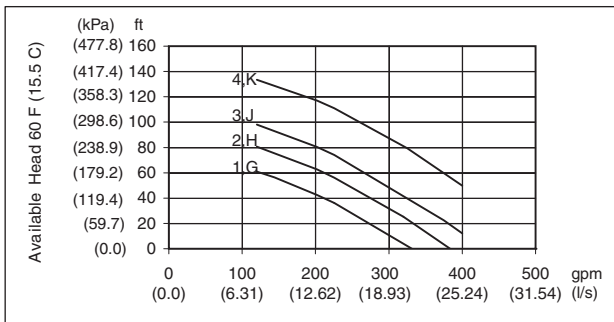

30XA140,142

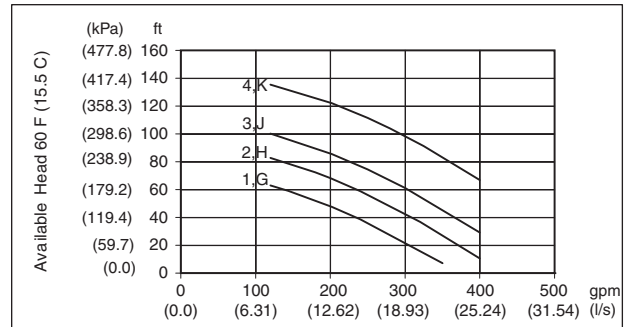

30XA110,112

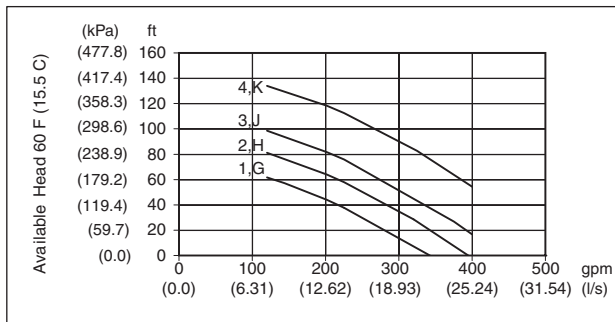

30XA160,162

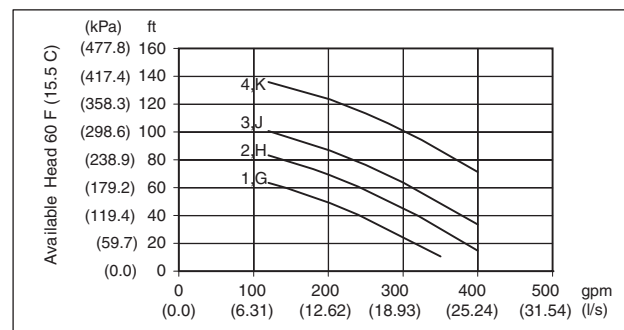

30XA120,122

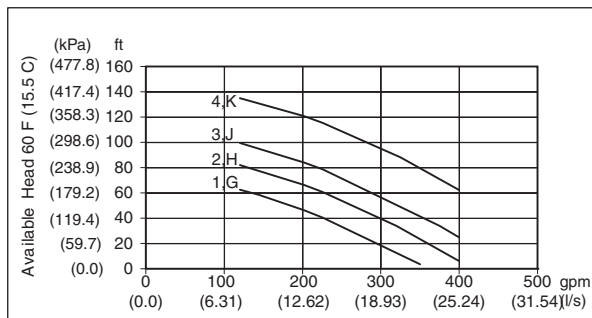

- Selection Pump**
- 1,G — Single 5Hp
 - 2,H — Single 7.5Hp
 - 3,J — Single 10Hp
 - 4,K — Single 15Hp

DUAL PUMP ENVELOPE CURVES (30XA090-162)

30XA090,092,100,102

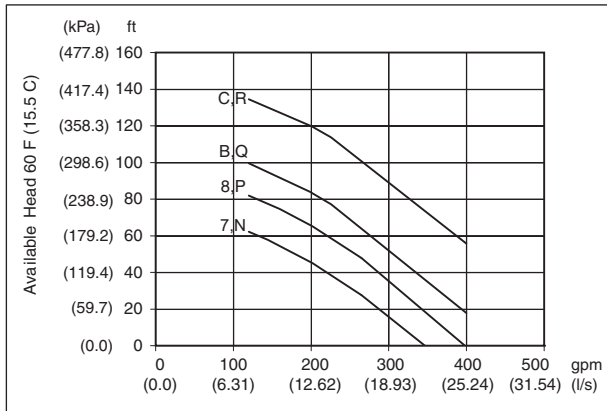

30XA140,142

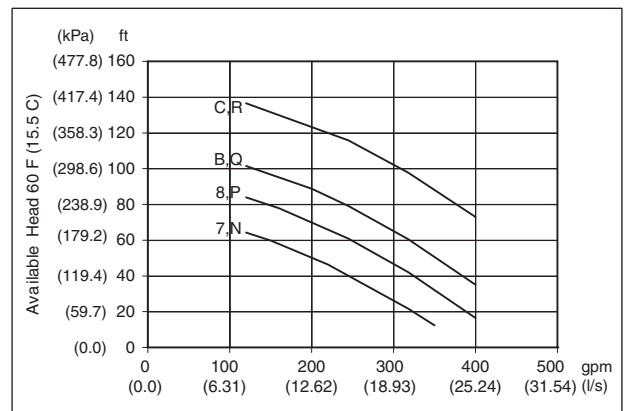

30XA110,112

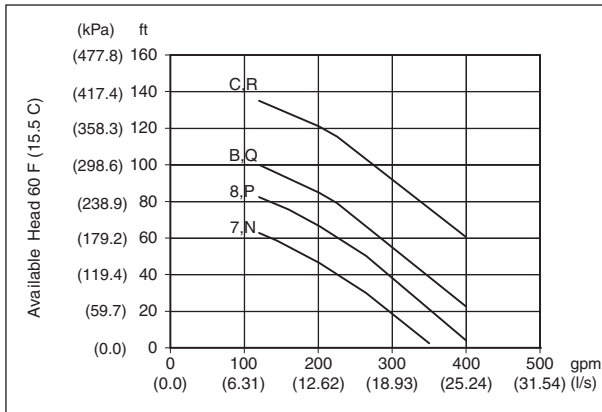

30XA160,162

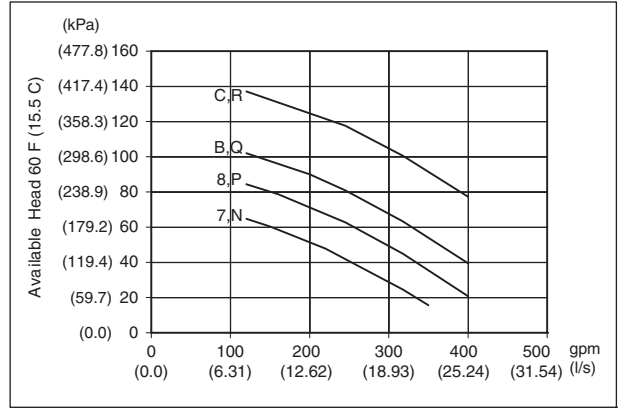

30XA120,122

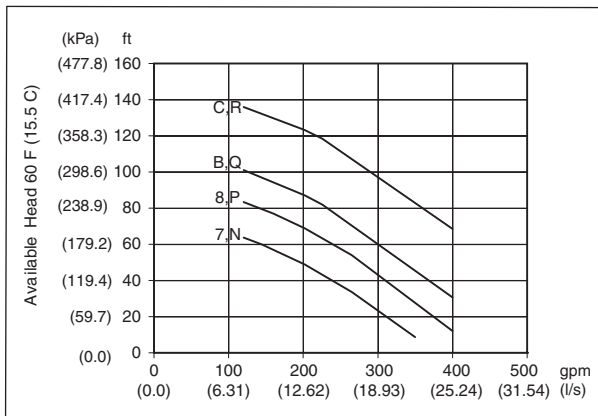

- Selection Pump**
- 7,N — Dual 5Hp
 - 8,P — Dual 7.5Hp
 - B,Q — Dual 10Hp
 - C,R — Dual 15Hp

PUMP CURVE I FOR HYDRONIC PACKAGE SINGLE PUMP (FRESH WATER)

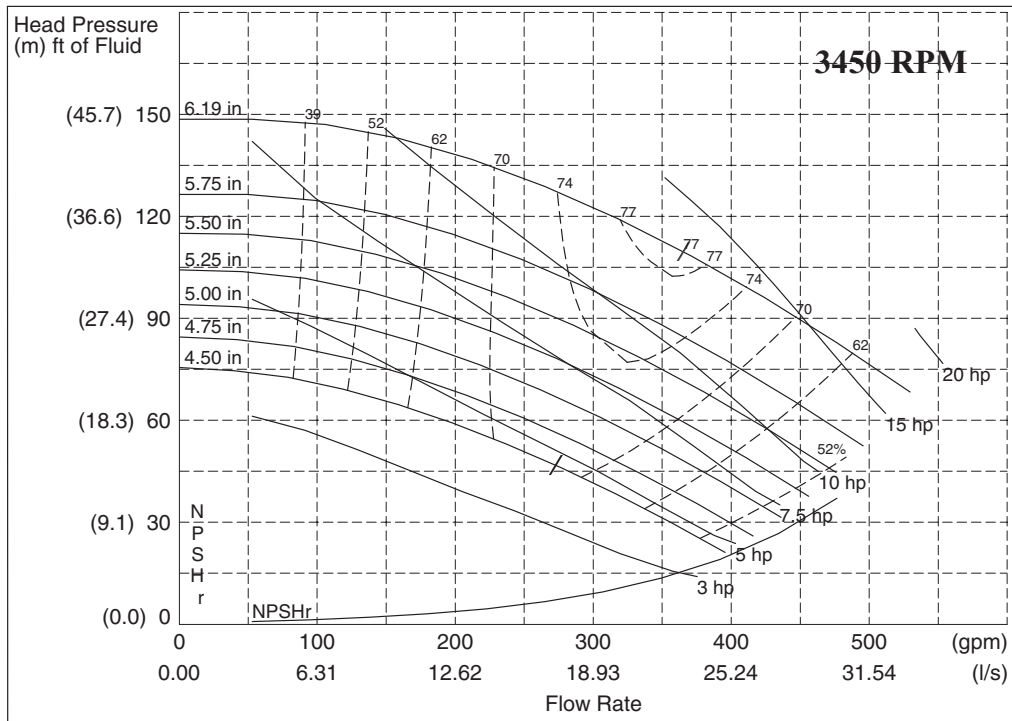

LEGEND

NPSHr — Net Positive Suction Head (Pressure) Required

NOTE: Refer to the Model Number Nomenclature for option identification. Refer to the Pump Impeller Sizes table on page 90 for more information.

PUMP CURVE II FOR HYDRONIC PACKAGE DUAL PUMP (FRESH WATER)

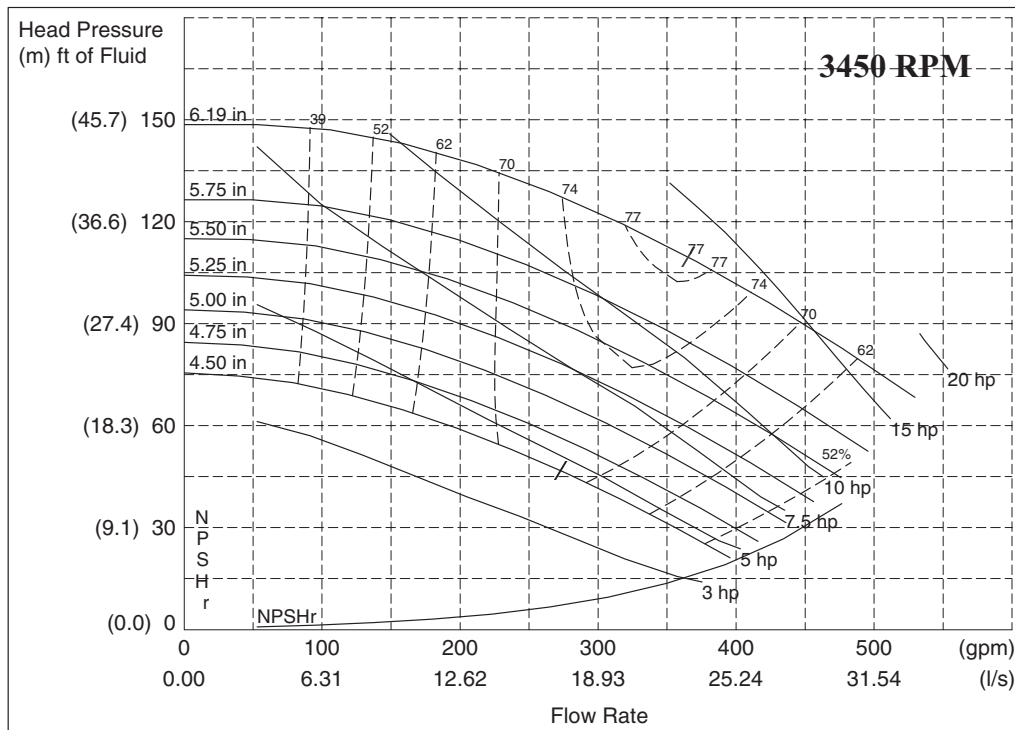

LEGEND

NPSHr — Net Positive Suction Head (Pressure) Required

NOTE: Refer to the Model Number Nomenclature for option identification. Refer to the Pump Impeller Sizes table on page 90 for more information.

COOLER PRESSURE DROP CURVES

30XA080, 090, 100, 110, 120

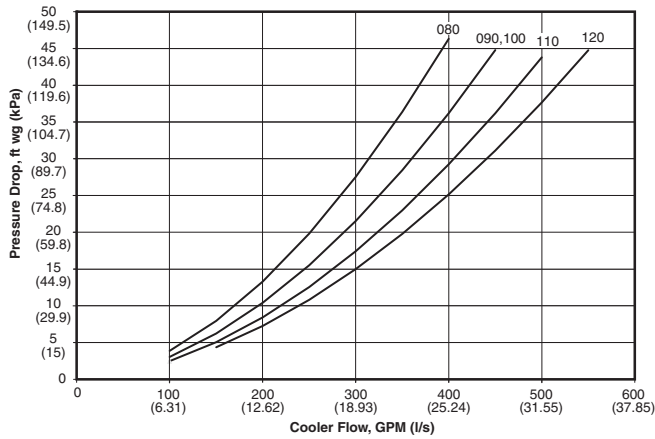

30XA140, 160, 180, 200, 220, 240

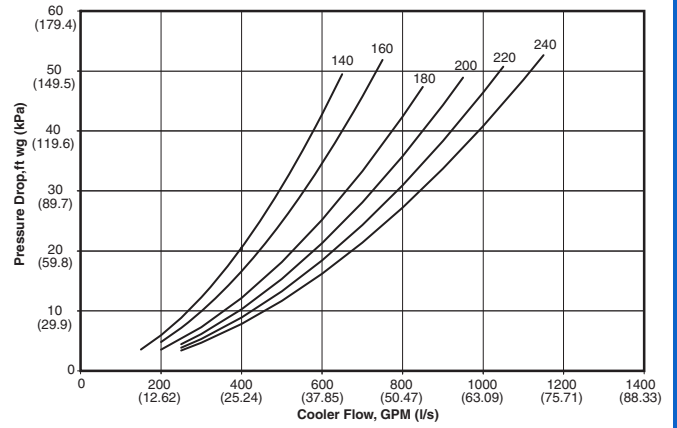

30XA260, 280, 300, 325, 350

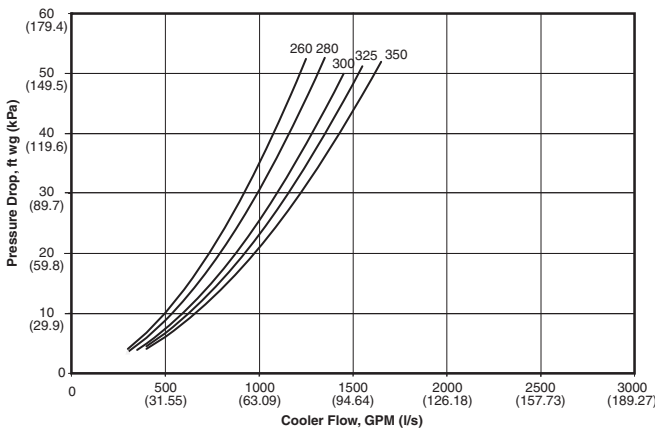

30XA082, 092, 102, 112, 122, 142, 162, 182, 202 (DX Cooler)

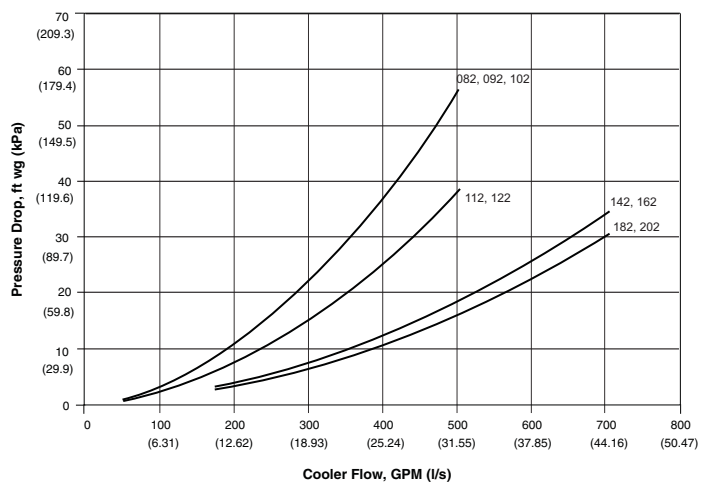

30XA222, 242, 262, 282, 302, 327, 352 (DX Cooler)

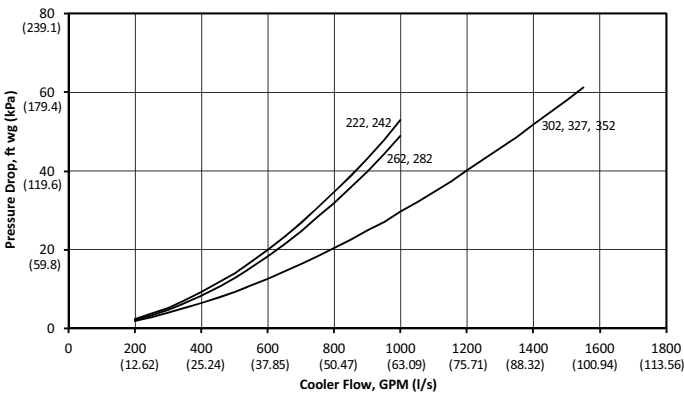

30XA401-501A

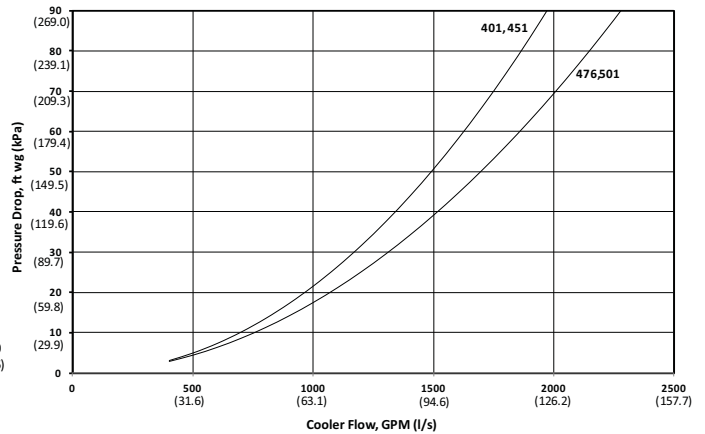

Typical piping and wiring (flooded cooler)

30XA UNITS WITHOUT HYDRONIC PACKAGE

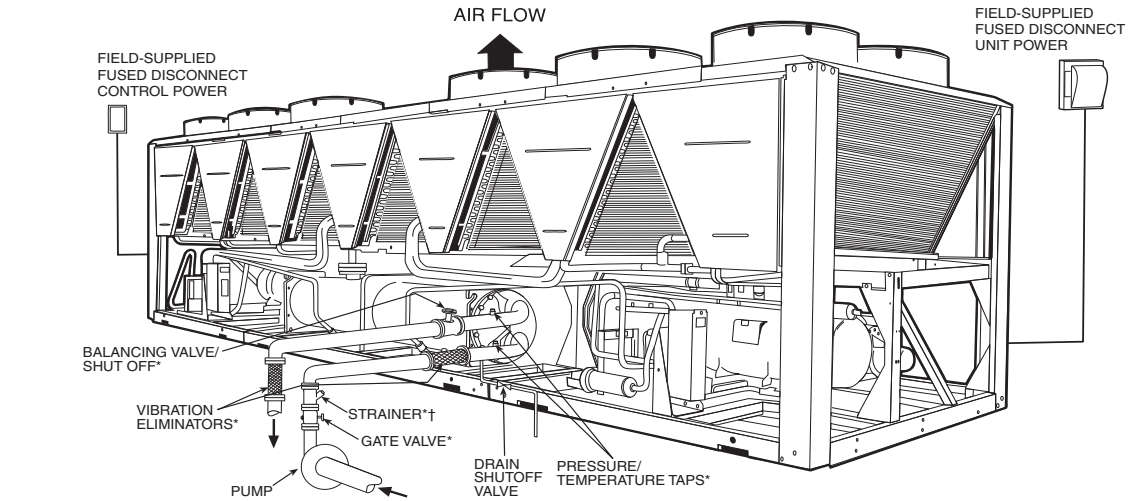

HEAT TAPE AND INSULATION ARE RECOMMENDED ON ALL EXPOSED PIPING IF AMBIENT TEMPERATURE <32°F (0°C) AND NO ANTIFREEZE SOLUTION IS IN SYSTEM

NOTES:

1. Chiller must be installed level to maintain proper compressor oil return.
2. Piping shown are general points-of-connection guides only and are not intended for a specific installation. Wiring and piping shown are for a quick overview of system and are not in accordance with recognized standards.
3. All wiring must comply with applicable local and national codes.
4. All piping must follow standard piping techniques. Refer to Carrier System Design Manual or appropriate ASHRAE (American Society of Heating, Refrigerating, and Air-Conditioning Engineers) handbook for details.
5. A 20-mesh strainer must be field-supplied and installed within 10 feet (3 meters) of the cooler inlet.

LEGEND

- Airflow Through Condenser
- Power Wiring
- Chilled Water Piping

*Field-installed.

†See note 5.

30XA UNITS WITH HYDRONIC PACKAGE

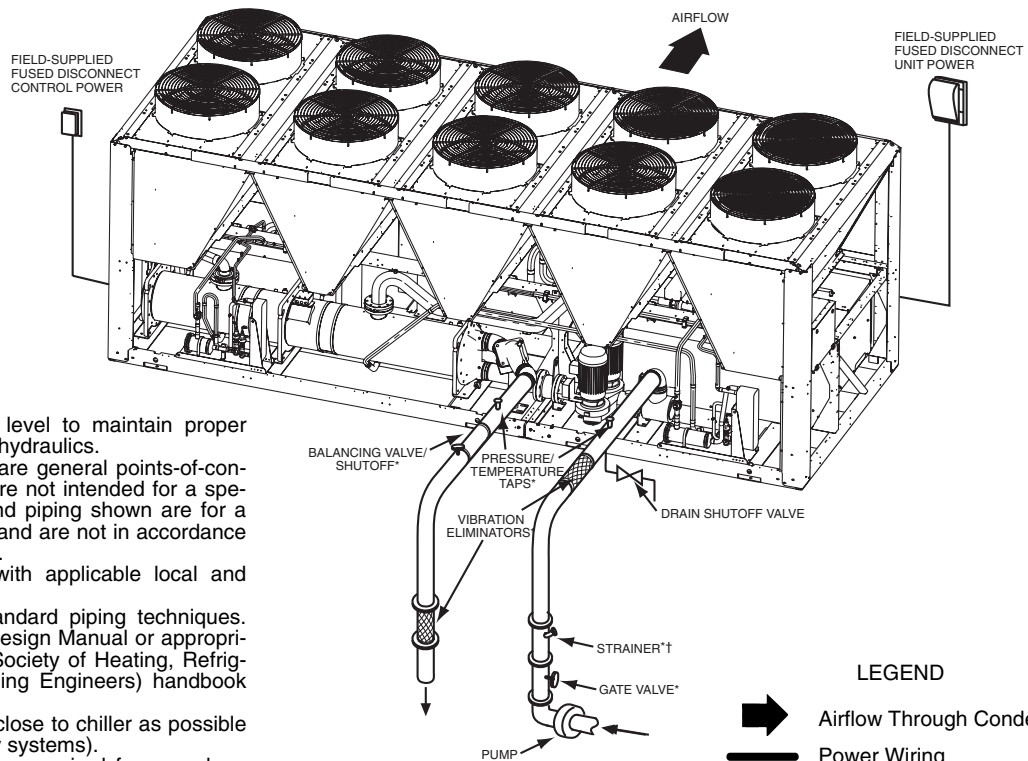

NOTES:

1. Chiller must be installed level to maintain proper compressor oil return and hydraulics.
2. Wiring and piping shown are general points-of-connection guides only and are not intended for a specific installation. Wiring and piping shown are for a quick overview of system and are not in accordance with recognized standards.
3. All wiring must comply with applicable local and national codes.
4. All piping must follow standard piping techniques. Refer to Carrier System Design Manual or appropriate ASHRAE (American Society of Heating, Refrigerating, and Air-Conditioning Engineers) handbook for details.
5. Air separator required as close to chiller as possible (except primary/secondary systems).
6. Additional 20 mesh strainer required for open loop systems.

LEGEND

- Airflow Through Condenser
- Power Wiring
- Chilled Water Piping

HEAT TAPE AND INSULATION ARE RECOMMENDED ON ALL EXPOSED PIPING IF AMBIENT TEMPERATURE <32°F (0°C) AND NO ANTIFREEZE SOLUTION IS IN SYSTEM

*Field-installed.

†See note 6.

Typical piping and wiring (DX cooler)

30XA UNITS WITHOUT HYDRONIC PACKAGE

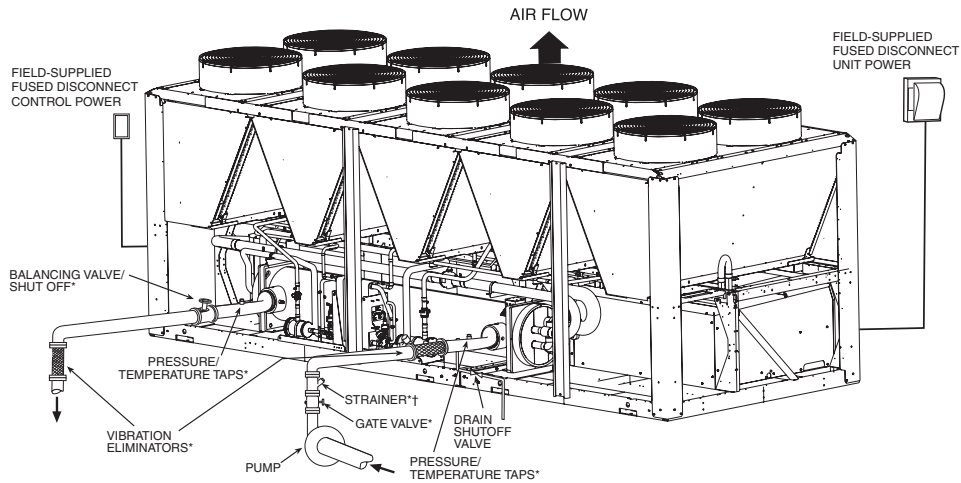

HEAT TAPE AND INSULATION ARE RECOMMENDED ON ALL EXPOSED PIPING IF AMBIENT TEMPERATURE <math> < 32^{\circ}\text{F}</math> ($0^{\circ}\text{C}</math>) AND NO ANTIFREEZE SOLUTION IS IN SYSTEM$

LEGEND

- Airflow Through Condenser
- Power Wiring
- Chilled Water Piping

*Field-installed.
†See note 5.

NOTES:

1. Chiller must be installed level to maintain proper compressor oil return.
2. Piping shown are general points-of-connection guides only and are not intended for a specific installation. Wiring and piping shown are for a quick overview of system and are not in accordance with recognized standards.
3. All wiring must comply with applicable local and national codes.
4. All piping must follow standard piping techniques. Refer to Carrier System Design Manual or appropriate ASHRAE (American Society of Heating, Refrigerating, and Air-Conditioning Engineers) handbook for details.
5. A 20-mesh strainer must be field-supplied and installed within 10 feet (3 meters) of the cooler inlet.

30XA UNITS WITH HYDRONIC PACKAGE

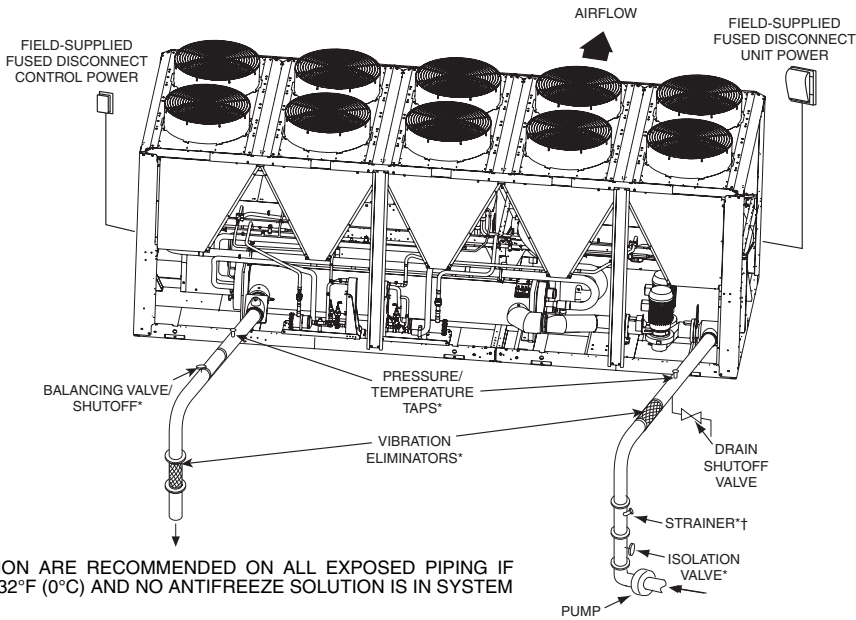

HEAT TAPE AND INSULATION ARE RECOMMENDED ON ALL EXPOSED PIPING IF AMBIENT TEMPERATURE <math> < 32^{\circ}\text{F}</math> ($0^{\circ}\text{C}</math>) AND NO ANTIFREEZE SOLUTION IS IN SYSTEM$

NOTES:

1. Chiller must be installed level to maintain proper compressor oil return and hydraulics.
2. Wiring and piping shown are general points-of-connection guides only and are not intended for a specific installation. Wiring and piping shown are for a quick overview of system and are not in accordance with recognized standards.
3. All wiring must comply with applicable local and national codes.
4. All piping must follow standard piping techniques. Refer to Carrier System Design Manual or appropriate ASHRAE (American Society of Heating, Refrigerating, and Air-Conditioning Engineers) handbook for details.
5. Air separator required as close to chiller as possible (except primary/secondary systems).
6. Additional 20 mesh strainer required for open loop systems.

LEGEND

- Airflow Through Condenser
- Power Wiring
- Chilled Water Piping

*Field-installed.
†See note 6.

TYPICAL PIPING DIAGRAM ON 30XA FLOODED COOLER UNITS WITHOUT HYDRONIC PACKAGE

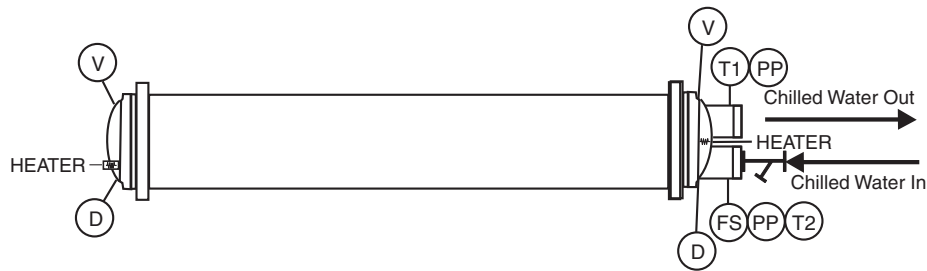

LEGEND

- D** — Drain, 3/4-in. NPT
- FS** — Flow Switch
- PP** — Pipe Plug, 1/4-in. NPT
- T1** — Leaving Water Thermistor
- T2** — Entering Water Thermistor
- V** — Vent, 1/4-in. NPT

TYPICAL PIPING DIAGRAM ON 30XA FLOODED COOLER UNITS WITH HYDRONIC PACKAGE — SINGLE PUMP

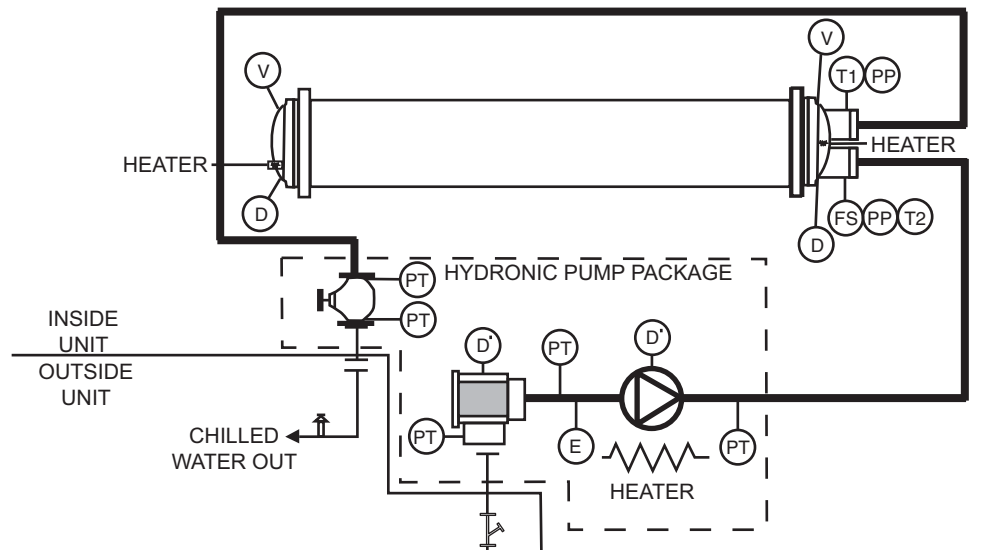

LEGEND

- D** — Drain, 3/4-in. NPT
- D'** — Drain, 1/4-in. NPT
- E** — Expansion Tank Connection, 3/4-in. NPT
- FS** — Flow Switch
- PP** — Pipe Plug, 1/4-in. NPT
- PT** — Pressure/Temperature Tap
- T1** — Leaving Water Thermistor
- T2** — Entering Water Thermistor
- V** — Vent, 1/4-in. NPT
- Indicates items provided with the optional hydronic pump package.

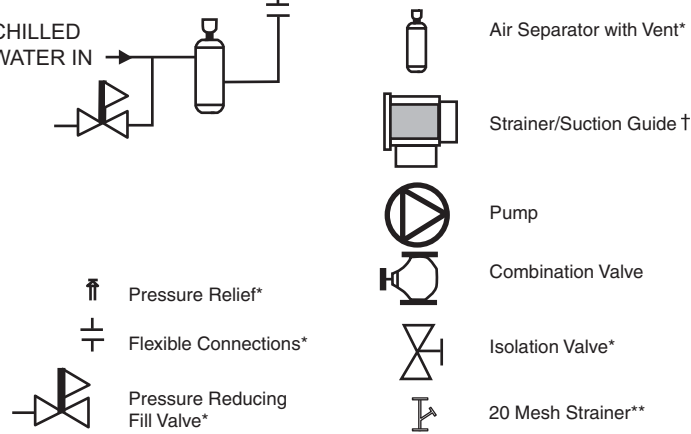

*Field-supplied and installed.
 †The strainer supplied with the optional hydronic pump package is 1/8 in. perforated.
 **Required for open loop systems.

TYPICAL PIPING DIAGRAM ON 30XA FLOODED COOLER UNITS WITH HYDRONIC PACKAGE — DUAL PUMPS

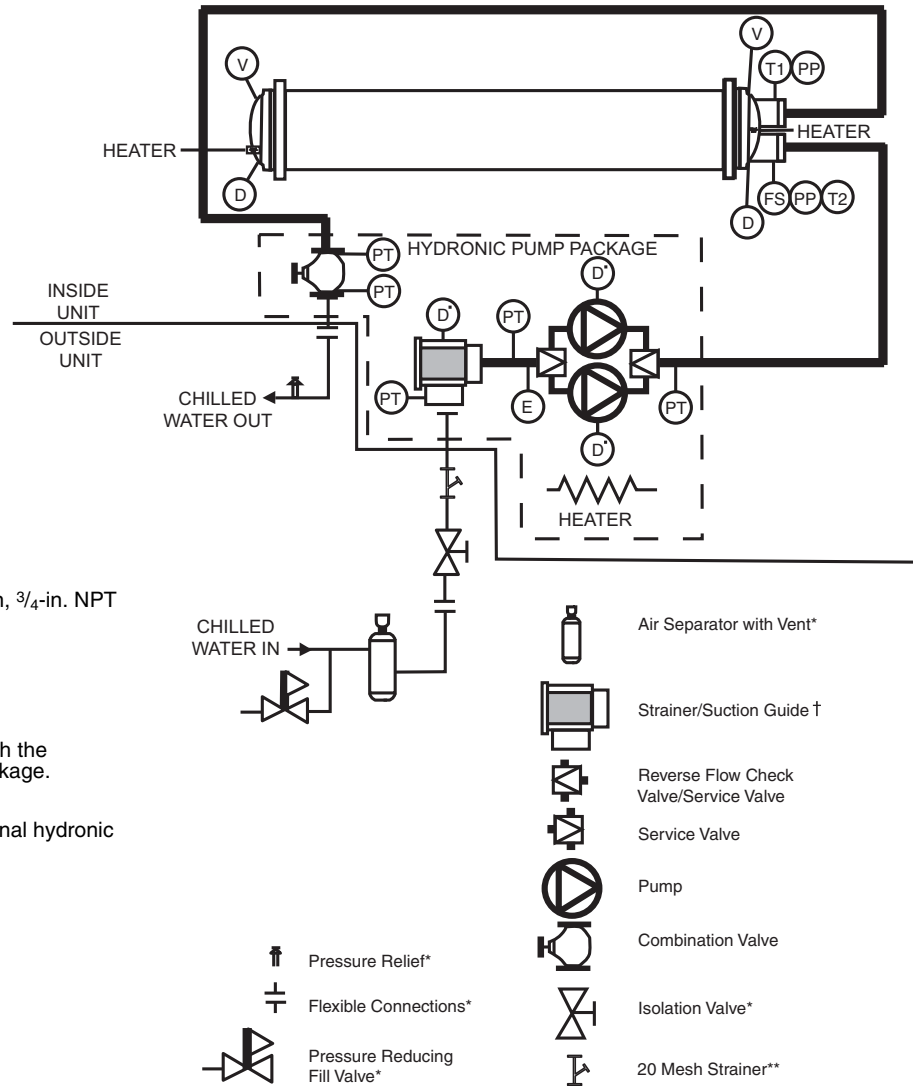

LEGEND

- D** — Drain, 3/4-in. NPT
- D'** — Drain, 1/4-in. NPT
- E** — Expansion Tank Connection, 3/4-in. NPT
- FS** — Flow Switch
- PP** — Pipe Plug, 1/4-in. NPT
- PT** — Pressure/Temperature Tap
- T1** — Leaving Water Thermistor
- T2** — Entering Water Thermistor
- V** — Vent, 1/4-in. NPT

--- Indicates items provided with the optional hydronic pump package.

*Field-supplied and installed.

†The strainer supplied with the optional hydronic pump package is 1/8 in. perforated.

**Required for open loop systems.

- Pressure Relief*
- Flexible Connections*
- Pressure Reducing Fill Valve*

- Air Separator with Vent*
- Strainer/Suction Guide †
- Reverse Flow Check Valve/Service Valve
- Service Valve
- Pump
- Combination Valve
- Isolation Valve*
- 20 Mesh Strainer**

TYPICAL PIPING DIAGRAM ON 30XA DX COOLER OPTION UNITS WITHOUT HYDRONIC PACKAGE

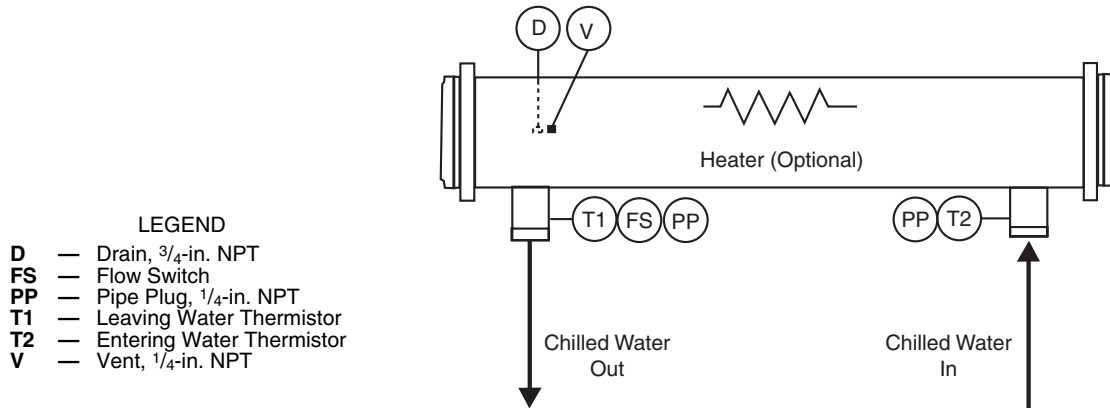

LEGEND

- D** — Drain, 3/4-in. NPT
- FS** — Flow Switch
- PP** — Pipe Plug, 1/4-in. NPT
- T1** — Leaving Water Thermistor
- T2** — Entering Water Thermistor
- V** — Vent, 1/4-in. NPT

TYPICAL PIPING DIAGRAM ON 30XA DX COOLER OPTION UNITS WITH HYDRONIC PACKAGE — SINGLE PUMP

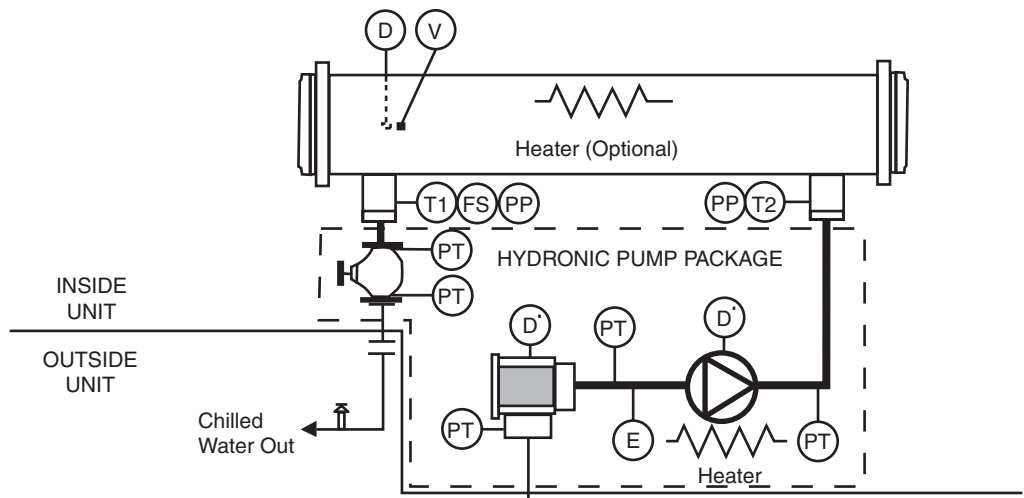

LEGEND

- D** — Drain, 3/4-in. NPT
- D'** — Drain, 1/4-in. NPT
- E** — Expansion Tank Connection, 3/4-in. NPT
- FS** — Flow Switch
- PP** — Pipe Plug, 1/4-in. NPT
- PT** — Pressure/Temperature Tap
- T1** — Leaving Water Thermistor
- T2** — Entering Water Thermistor
- V** — Vent, 1/4-in. NPT

--- Indicates items provided with the optional hydronic pump package.

*Field-supplied and installed.
 †The strainer supplied with the optional hydronic pump package is 1/8 in. perforated.
 **Required for open loop systems.

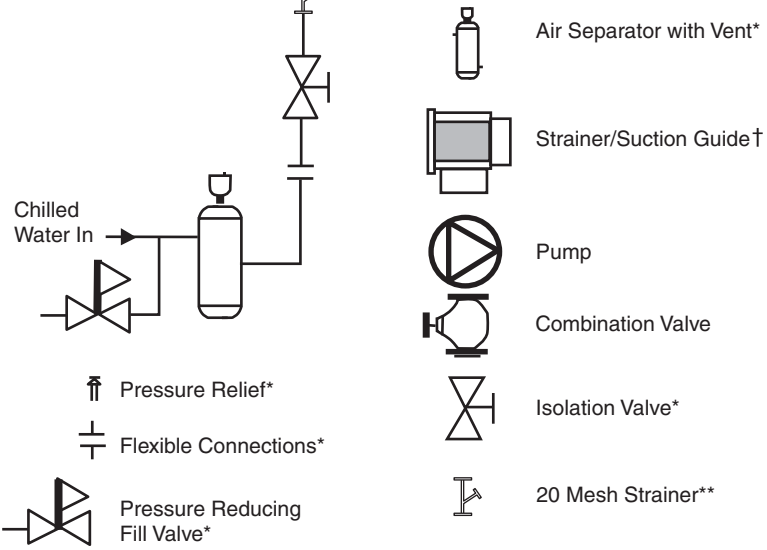

TYPICAL PIPING DIAGRAM ON 30XA DX COOLER OPTION UNITS WITH HYDRONIC PACKAGE — DUAL PUMPS

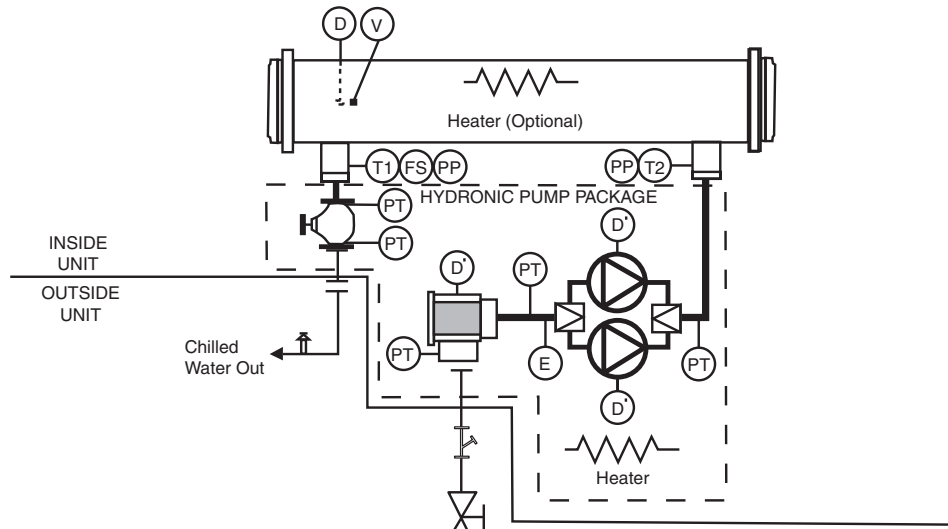

LEGEND

- D** — Drain, 3/4-in. NPT
- D'** — Drain, 1/4-in. NPT
- E** — Expansion Tank Connection, 3/4-in. NPT
- FS** — Flow Switch
- PP** — Pipe Plug, 1/4-in. NPT
- PT** — Pressure/Temperature Tap
- T1** — Leaving Water Thermistor
- T2** — Entering Water Thermistor
- V** — Vent, 1/4-in. NPT
- Indicates items provided with the optional hydronic pump package.

*Field-supplied and installed.
 †The strainer supplied with the optional hydronic pump package is 1/8 in. perforated.
 **Required for open loop systems.

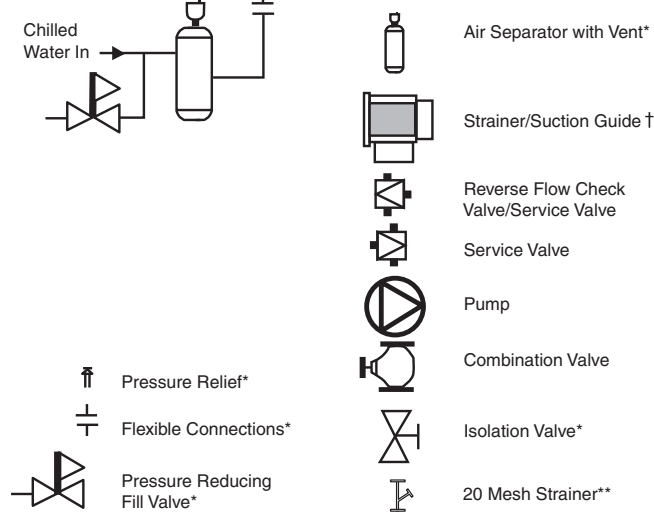

SINGLE POINT (STANDARD CONDENSER FAN MOTORS) (cont)

UNIT 30XA	UNIT VOLTAGE			NUMBER OF COND FANS	10 HP PUMP, 3450 RPM					15 HP PUMP, 3450 RPM					CONTROL CIRCUIT	
	V-Hz (3 Ph)	Supplied			MCA	MOCP	ICF		Rec Fuse Size	MCA	MOCP	ICF		Rec Fuse Size	Voltage 1 PH, 60 Hz	MCA and MOCP
		Min	Max				WD	XL				WD	XL			
080, 082	230-60	207	253	6	—	—	—	—	—	—	—	—	—	115	40	
	200-60	187	220	6	—	—	—	—	—	—	—	—	—	115	40	
	460-60	414	506	6	—	—	—	—	—	—	—	—	—	115	40	
	575-60	518	633	6	—	—	—	—	—	—	—	—	—	115	40	
	380-60	342	418	6	—	—	—	—	—	—	—	—	—	115	40	
090, 092	230-60	207	253	8	364.4	450	529.5	1215.5	400	379.0	500	544.1	1230.1	450	115	40
	200-60	187	220	8	401.6	500	599.6	1388.6	450	417.7	500	615.8	1404.8	500	115	40
	460-60	414	506	8	182.2	225	264.8	607.8	200	189.5	250	272.1	615.1	225	115	40
	575-60	518	633	8	140.6	175	209.9	483.9	175	146.5	175	215.8	489.8	175	115	40
	380-60	342	418	8	212.9	250	317.0	732.0	250	221.8	250	325.8	740.8	250	115	40
100, 102	230-60	207	253	8	395.0	500	567.1	1309.1	450	409.6	500	581.7	1323.7	450	115	40
	200-60	187	220	8	434.9	500	641.5	1495.5	500	451.1	600	657.6	1511.6	500	115	40
	460-60	414	506	8	197.5	250	283.6	654.6	225	204.8	250	290.9	661.9	225	115	40
	575-60	518	633	8	151.7	200	223.8	520.8	175	157.5	200	229.7	526.7	175	115	40
	380-60	342	418	8	231.1	300	340.1	789.1	300	239.9	300	348.9	797.9	300	115	40
110, 112	230-60	207	253	8	436.1	600	567.1	—	500	450.7	600	581.7	—	500	115	40
	200-60	187	220	8	479.9	600	641.5	—	600	496.0	600	657.6	—	600	115	40
	460-60	414	506	8	217.6	300	283.6	654.6	250	224.9	300	290.9	661.9	250	115	40
	575-60	518	633	8	167.7	225	223.8	520.8	200	173.5	225	229.7	526.7	200	115	40
	380-60	342	418	8	254.8	350	340.1	789.1	300	263.6	350	348.9	797.9	300	115	40
120, 122	230-60	207	253	8	469.0	600	600.0	—	600	483.6	600	614.6	—	600	115	40
	200-60	187	220	8	515.8	700	677.4	—	600	531.9	700	693.5	—	600	115	40
	460-60	414	506	8	233.6	300	299.6	670.6	300	240.9	300	306.9	677.9	300	115	40
	575-60	518	633	8	180.5	225	236.7	533.7	200	186.4	250	242.5	539.5	225	115	40
	380-60	342	418	8	273.7	350	359.0	808.0	300	282.6	350	367.9	816.9	350	115	40
140, 142	230-60	207	253	10	565.1	800	827.1	—	700	579.7	800	841.7	—	700	115	40
	200-60	187	220	10	622.1	800	939.7	—	700	638.2	800	955.9	—	800	115	40
	460-60	414	506	10	282.5	400	413.6	1045.6	350	289.8	400	420.9	1052.9	350	115	40
	575-60	518	633	10	217.1	300	327.6	833.6	250	223.0	300	333.5	839.5	250	115	40
	380-60	342	418	10	329.6	450	497.3	1262.3	400	338.5	450	506.2	1271.2	400	115	40
160, 162	230-60	207	253	10	651.5	800	1028.0	—	800	666.1	800	1042.6	—	800	115	40
	200-60	187	220	10	716.4	1000	1169.7	—	1000	732.6	1000	1185.8	—	1000	115	40
	460-60	414	506	10	324.9	450	513.6	1321.6	400	332.2	450	520.9	1328.9	400	115	40
	575-60	518	633	10	250.2	350	408.5	1054.5	300	256.1	350	414.3	1060.3	300	115	40
	380-60	342	418	10	379.5	500	617.3	1596.3	450	388.4	500	626.1	1605.1	450	115	40
180, 182	230-60	207	253	12	—	—	—	—	—	—	—	—	—	—	115	60
	200-60	187	220	12	—	—	—	—	—	—	—	—	—	—	115	60
	460-60	414	506	12	—	—	—	—	—	—	—	—	—	—	115	60
	575-60	518	633	12	—	—	—	—	—	—	—	—	—	—	115	60
	380-60	342	418	12	—	—	—	—	—	—	—	—	—	—	115	60
200, 202	230-60	207	253	12	—	—	—	—	—	—	—	—	—	—	115	60
	200-60	187	220	12	—	—	—	—	—	—	—	—	—	—	115	60
	460-60	414	506	12	—	—	—	—	—	—	—	—	—	—	115	60
	575-60	518	633	12	—	—	—	—	—	—	—	—	—	—	115	60
	380-60	342	418	12	—	—	—	—	—	—	—	—	—	—	115	60
220, 222	230-60	207	253	13	—	—	—	—	—	—	—	—	—	—	115	60
	200-60	187	220	13	—	—	—	—	—	—	—	—	—	—	115	60
	460-60	414	506	13	—	—	—	—	—	—	—	—	—	—	115	60
	575-60	518	633	13	—	—	—	—	—	—	—	—	—	—	115	60
	380-60	342	418	13	—	—	—	—	—	—	—	—	—	—	115	60
240, 242	230-60	207	253	13	—	—	—	—	—	—	—	—	—	—	115	60
	200-60	187	220	13	—	—	—	—	—	—	—	—	—	—	115	60
	460-60	414	506	13	—	—	—	—	—	—	—	—	—	—	115	60
	575-60	518	633	13	—	—	—	—	—	—	—	—	—	—	115	60
	380-60	342	418	13	—	—	—	—	—	—	—	—	—	—	115	60
260, 262	460-60	414	506	15	—	—	—	—	—	—	—	—	—	—	115	60
	575-60	518	633	15	—	—	—	—	—	—	—	—	—	—	115	60
	380-60	342	418	15	—	—	—	—	—	—	—	—	—	—	115	60
280, 282	460-60	414	506	16	—	—	—	—	—	—	—	—	—	—	115	60
	575-60	518	633	16	—	—	—	—	—	—	—	—	—	—	115	60
	380-60	342	418	16	—	—	—	—	—	—	—	—	—	—	115	60
300, 302	460-60	414	506	16	—	—	—	—	—	—	—	—	—	—	115	60
	575-60	518	633	16	—	—	—	—	—	—	—	—	—	—	115	60
	380-60	342	418	16	—	—	—	—	—	—	—	—	—	—	115	60
325, 327	460-60	414	506	18	—	—	—	—	—	—	—	—	—	—	115	60
	575-60	518	633	18	—	—	—	—	—	—	—	—	—	—	115	60
	380-60	342	418	18	—	—	—	—	—	—	—	—	—	—	115	60
350, 352	460-60	414	506	18	—	—	—	—	—	—	—	—	—	—	115	60
	575-60	518	633	18	—	—	—	—	—	—	—	—	—	—	115	60
	380-60	342	418	18	—	—	—	—	—	—	—	—	—	—	115	60

LEGEND

- ICF — Instantaneous Current Flow
- MCA — Minimum Circuit Amps
- MOCP — Maximum Overcurrent Protection
- WD — Wye-Delta
- XL — Across-the-Line

NOTES:

1. Units are suitable for use on electrical systems where voltage supplied to the unit terminals is not below or above the listed minimum and maximum limits. Maximum allowable phase imbalance is: voltage, 2%; amps 10%.
2. Cooler heater (where applicable) is wired into the control circuit so it is always operable as long as the control power supply disconnect is on, even if any safety device is open.
3. For MCA that is less than or equal to 380 amps, 3 conductors are required.
For MCA between 381-760 amps, 6 conductors are required.
For MCA between 761-1140 amps, 9 conductors are required.
For MCA between 1141-1520 amps, 12 conductors are required.
Calculation of conductors required is based on 75 C copper wire.

4. Wiring for main field supply must be rated 75 C minimum. Use copper for all units.
 - a. Incoming wire size range for the terminal block is no. 4 AWG (American Wire Gage) to 500 kcmil.
 - b. Incoming wire size range of non-fused disconnect with MCA up to 599.9 amps is 3/0 to 500 kcmil.
 - c. Incoming wire size range of non-fused disconnect with MCA from 600 to 799.9 amps is 1/0 to 500 kcmil.
 - d. Incoming wire size range of non-fused disconnect with MCA from 800 to 1199.9 amps is 250 kcmil to 500 kcmil.
5. Data provided as circuit 1/circuit 2 where there are two circuits.
6. Standard condenser fan motors are not used with sizes 30XA401-501. These sizes use high ambient temperature condenser fans.



Electrical data (cont)



DUAL POINT (STANDARD CONDENSER FAN MOTORS)

UNIT 30XA	UNIT VOLTAGE		NUMBER OF COND FANS	NO HYDRONIC PACKAGE					5 HP PUMP, 3450 RPM					CONTROL CIRCUIT		
	V-Hz (3 Ph)	Supplied		MCA	MOCP	ICF		Rec Fuse Size	MCA	MOCP	ICF		Rec Fuse Size	Voltage 1 PH, 60 Hz	MCA and MOCP	
		Min				Max	WD				XL	WD				XL
080, 082	230-60	207	253	3/3	173.3/173.3	250/ 250	342.0/342.0	1028.0/1028.0	225/225	—	—	—	—	115	40	
	200-60	187	220	3/3	190.9/190.9	300/ 300	392.9/392.9	1181.9/1181.9	250/250	—	—	—	—	115	40	
	460-60	414	506	3/3	86.6/ 86.6	125/ 125	171.0/171.0	514.0/ 514.0	110/110	—	—	—	—	115	40	
	575-60	518	633	3/3	66.5/ 66.5	110/ 110	137.2/137.2	411.2/ 411.2	80/ 80	—	—	—	—	115	40	
	380-60	342	418	3/3	100.7/100.7	150/ 150	206.9/206.9	621.9/ 621.9	125/125	—	—	—	—	115	40	
090, 092	230-60	207	253	4/4	182.9/182.9	300/ 300	348.0/348.0	1034.0/1034.0	225/225	182.9/198.9	300/300	348.0/364.0	1034.0/1050.0	225/250	115	40
	200-60	187	220	4/4	201.5/201.5	300/ 300	399.5/399.5	1188.5/1188.5	250/250	201.5/219.2	300/350	399.5/417.2	1188.5/1206.2	250/300	115	40
	460-60	414	506	4/4	91.4/ 91.4	150/ 150	174.0/174.0	517.0/ 517.0	110/110	91.4/ 99.4	150/150	174.0/182.0	517.0/ 525.0	110/125	115	40
	575-60	518	633	4/4	70.3/ 70.3	110/ 110	139.6/139.6	413.6/ 413.6	90/ 90	70.3/ 76.7	110/125	139.6/146.0	413.6/ 420.0	90/ 90	115	40
	380-60	342	418	4/4	106.5/106.5	175/ 175	210.5/210.5	625.5/ 625.5	125/125	106.5/116.1	175/175	210.5/220.2	625.5/ 635.2	125/150	115	40
100, 102	230-60	207	253	4/4	199.9/199.9	300/ 300	372.0/372.0	1114.0/1114.0	250/250	199.9/215.9	300/350	372.0/388.0	1114.0/1130.0	250/300	115	40
	200-60	187	220	4/4	220.0/220.0	350/ 350	426.5/426.5	1280.5/1280.5	300/300	220.0/237.7	350/350	426.5/444.2	1280.5/1298.2	300/300	115	40
	460-60	414	506	4/4	99.9/ 99.9	150/ 150	186.0/186.0	557.0/ 557.0	125/125	99.9/107.9	150/175	186.0/194.0	557.0/ 565.0	125/150	115	40
	575-60	518	633	4/4	76.4/ 76.4	125/ 125	148.6/148.6	445.6/ 445.6	90/ 90	76.4/ 82.8	125/125	148.6/155.0	445.6/ 452.0	90/100	115	40
	380-60	342	418	4/4	116.5/116.5	175/ 175	225.5/225.5	674.5/ 674.5	150/150	116.5/126.2	175/200	225.5/235.2	674.5/ 684.2	150/150	115	40
110, 112	230-60	207	253	4/4	241.0/199.9	400/ 300	372.0/372.0	—	300/250	241.0/215.9	400/350	372.0/388.0	—	300/300	115	40
	200-60	187	220	4/4	264.9/220.0	450/ 350	426.5/426.5	—	350/300	264.9/237.7	450/350	426.5/444.2	—	350/300	115	40
	460-60	414	506	4/4	120.0/ 99.9	200/ 150	186.0/186.0	557.0/557.0	150/125	120.0/107.9	200/175	186.0/194.0	557.0/ 565.0	150/150	115	40
	575-60	518	633	4/4	92.5/ 76.4	150/ 125	148.6/148.6	445.6/445.6	110/ 90	92.5/ 82.8	150/125	148.6/155.0	445.6/ 452.0	110/100	115	40
	380-60	342	418	4/4	140.2/116.5	225/ 175	225.5/225.5	674.5/674.5	175/150	140.2/126.2	225/200	225.5/235.2	674.5/ 684.2	175/150	115	40
120, 122	230-60	207	253	4/4	241.0/241.0	400/ 400	372.0/372.0	—	300/300	241.0/257.0	400/400	372.0/388.0	—	300/350	115	40
	200-60	187	220	4/4	264.9/264.9	450/ 450	426.5/426.5	—	350/350	264.9/282.6	450/450	426.5/444.2	—	350/350	115	40
	460-60	414	506	4/4	120.0/120.0	200/ 200	186.0/186.0	557.0/557.0	150/150	120.0/128.0	200/200	186.0/194.0	557.0/ 565.0	150/150	115	40
	575-60	518	633	4/4	92.5/ 92.5	150/ 150	148.6/148.6	445.6/445.6	110/110	92.5/ 98.9	150/150	148.6/155.0	445.6/ 452.0	110/125	115	40
	380-60	342	418	4/4	140.2/140.2	225/ 225	225.5/225.5	674.5/674.5	175/175	140.2/149.9	225/250	225.5/235.2	674.5/ 684.2	175/200	115	40
140, 142	230-60	207	253	6/4	370.0/199.9	600/ 300	632.0/372.0	—	450/250	370.0/215.9	600/350	632.0/388.0	—	450/300	115	40
	200-60	187	220	6/4	407.2/220.0	700/ 350	724.8/426.5	—	500/300	407.2/237.7	700/350	724.8/444.2	—	500/300	115	40
	460-60	414	506	6/4	185.0/ 99.9	300/ 150	316.0/186.0	948.0/557.0	225/125	185.0/107.9	300/175	316.0/194.0	948.0/ 565.0	225/150	115	40
	575-60	518	633	6/4	141.9/ 76.4	225/ 125	252.4/148.6	758.4/445.6	175/ 90	141.9/ 82.8	225/125	252.4/155.0	758.4/ 452.0	175/100	115	40
	380-60	342	418	6/4	215.1/116.5	350/ 175	382.8/225.5	1147.8/674.5	300/150	215.1/126.2	350/200	382.8/235.2	1147.8/ 684.2	300/150	115	40
160, 162	230-60	207	253	6/4	423.5/241.0	700/ 400	800.0/372.0	—	600/300	423.5/257.0	700/400	800.0/388.0	—	600/350	115	40
	200-60	187	220	6/4	465.6/264.9	800/ 450	918.8/426.5	—	600/350	465.6/282.6	800/450	918.8/444.2	—	600/350	115	40
	460-60	414	506	6/4	211.3/120.0	350/ 200	400.0/186.0	1208.0/557.0	250/150	211.3/128.0	350/200	400.0/194.0	1208.0/ 565.0	250/150	115	40
	575-60	518	633	6/4	162.2/ 92.5	250/ 150	320.4/148.6	966.4/445.6	200/110	162.2/ 98.9	250/150	320.4/155.0	966.4/ 452.0	200/125	115	40
	380-60	342	418	6/4	246.0/140.2	400/ 225	483.8/225.5	1462.8/674.5	300/175	246.0/149.9	400/250	483.8/235.2	1462.8/ 684.2	300/200	115	40
180, 182	230-60	207	253	6/6	376.0/370.0	600/ 600	632.0/632.0	—	450/450	—	—	—	—	—	115	60
	200-60	187	220	6/6	407.2/407.2	700/ 700	724.8/724.8	—	500/500	—	—	—	—	—	115	60
	460-60	414	506	6/6	185.0/185.0	300/ 300	316.0/316.0	948.0/ 948.0	225/225	—	—	—	—	—	115	60
	575-60	518	633	6/6	141.9/141.9	225/ 225	252.4/252.4	758.4/ 758.4	175/175	—	—	—	—	—	115	60
	380-60	342	418	6/6	215.1/215.1	350/ 350	382.8/382.8	1147.8/1147.8	300/300	—	—	—	—	—	115	60
200, 202	230-60	207	253	6/6	423.5/423.5	700/ 700	800.0/800.0	—	600/600	—	—	—	—	—	115	60
	200-60	187	220	6/6	465.6/465.6	800/ 800	918.8/918.8	—	600/600	—	—	—	—	—	115	60
	460-60	414	506	6/6	211.3/211.3	350/ 350	400.0/400.0	1208.0/1208.0	250/250	—	—	—	—	—	115	60
	575-60	518	633	6/6	162.2/162.2	250/ 250	320.4/320.4	966.4/ 966.4	200/200	—	—	—	—	—	115	60
	380-60	342	418	6/6	246.0/246.0	400/ 400	483.8/483.8	1462.8/1462.8	300/300	—	—	—	—	—	115	60
220, 222	230-60	207	253	7/6	504.2/423.5	800/ 700	806.0/800.0	—	600/600	—	—	—	—	—	115	60
	200-60	187	220	7/6	554.7/465.6	800/ 800	925.4/918.8	—	700/600	—	—	—	—	—	115	60
	460-60	414	506	7/6	252.1/211.3	400/ 350	403.0/400.0	1211.0/1208.0	300/250	—	—	—	—	—	115	60
	575-60	518	633	7/6	193.7/162.2	300/ 250	322.8/320.4	968.8/ 966.4	250/200	—	—	—	—	—	115	60
	380-60	342	418	7/6	293.3/246.0	500/ 400	487.4/483.8	1466.4/1462.8	350/300	—	—	—	—	—	115	60
240, 242	230-60	207	253	7/6	504.2/498.2	800/ 800	806.0/800.0	—	600/600	—	—	—	—	—	115	60
	200-60	187	220	7/6	554.7/548.0	800/ 800	925.4/918.8	—	700/700	—	—	—	—	—	115	60
	460-60	414	506	7/6	252.1/249.1	400/ 400	403.0/400.0	1211.0/1208.0	300/300	—	—	—	—	—	115	60
	575-60	518	633	7/6	193.7/191.3	300/ 300	322.8/320.4	968.8/ 966.4	250/250	—	—	—	—	—	115	60
	380-60	342	418	7/6	293.3/289.7	500/ 500	487.4/483.8	1466.4/1462.8	350/350	—	—	—	—	—	115	60
260, 262	460-60	414	506	9/6	343.9/211.3	500/ 350	605.0/400.0	1827.0/1208.0	450/250	—	—	—	—	—	115	60
	575-60	518	633	9/6	263.8/162.2	450/ 250	483.6/320.4	1461.6/ 966.4	350/200	—	—	—	—	—	115	60
	380-60	342	418	9/6	399.0/246.0	600/ 400	732.7/483.8	2211.7/1462.8	500/300	—	—	—	—	—	115	60
280, 282	460-60	414	506	9/7	343.9/252.1	500/ 400	605.0/403.0	1827.0/1211.0	450/300	—	—	—	—	—	115	60
	575-60	518	633	9/7	263.8/193.7	450/ 300	483.6/322.8	1461.6/ 968.8	350/250	—	—	—	—	—	115	60
	380-60	342	418	9/7	399.0/293.3	600/ 500	732.7/487.4	2211.7/1466.4	500/350	—	—	—	—	—	115	60
300, 302	460-60	414	506	10/6	408.0/249.1	700/ 400	608.0/400.0	1830.0/1208.0	500/300	—	—	—	—	—	115	60
	575-60	518	633	10/6	312.8/191.3	500/ 300	486.0/320.4	1464.0/ 966.4	400/250	—	—	—	—	—	115	60
	380-60	342	418	10/6	474.2/289.7	800/ 500	736.3/483.8	2215.3/1462.8	600/350	—	—	—	—	—	115	60
325, 327	460-60	414	506	9/9	343.9/343.9	500/ 500	605.0/605.0	1827.0/1827.0	450/450	—	—	—	—	—	115	60
	575-60	518	633	9/9	263.8/263.8	450/ 450	483.6/483.6	1461.6/1461.6	350/350	—	—	—	—	—	115	60
	380-60	342	418	9/9	399.0/399.0	600/ 600	732.7/732.7	2211.7/2211.7	500/500	—	—	—	—	—	115	60
350,																

DUAL POINT (STANDARD CONDENSER FAN MOTORS) (cont)

UNIT 30XA	UNIT VOLTAGE			NUMBER OF COND FANS	15 HP PUMP, 3450 RPM					CONTROL CIRCUIT	
	V-Hz (3 Ph)	Supplied			MCA	MOCP	ICF		Rec Fuse Size	Voltage 1 PH, 60 Hz	MCA and MOCP
		Min	Max				WD	XL			
080, 082	230-60	207	253	3/3	—	—	—	—	—	115	40
	200-60	187	220	3/3	—	—	—	—	—	115	40
	460-60	414	506	3/3	—	—	—	—	—	115	40
	575-60	518	633	3/3	—	—	—	—	—	115	40
	380-60	342	418	3/3	—	—	—	—	—	115	40
090, 092	230-60	207	253	4/4	182.9/227.9	300/350	348.0/393.0	1034.0/1079.0	225/300	115	40
	200-60	187	220	4/4	201.5/251.2	300/350	399.5/449.3	1188.5/1238.3	250/300	115	40
	460-60	414	506	4/4	91.4/113.9	150/175	174.0/196.5	517.0/ 539.5	110/150	115	40
	575-60	518	633	4/4	70.3/ 88.3	110/125	139.6/157.6	413.6/ 431.6	90/110	115	40
	380-60	342	418	4/4	106.5/133.7	175/200	210.5/237.8	625.5/ 652.8	125/175	115	40
100, 102	230-60	207	253	4/4	199.9/244.9	300/350	372.0/417.0	1114.0/1159.0	250/300	115	40
	200-60	187	220	4/4	220.0/269.8	350/400	426.5/476.3	1280.5/1330.3	300/350	115	40
	460-60	414	506	4/4	99.9/122.4	150/175	186.0/208.5	557.0/ 579.5	125/150	115	40
	575-60	518	633	4/4	76.4/ 94.4	125/125	148.6/166.6	445.6/ 463.6	90/110	115	40
	380-60	342	418	4/4	116.5/143.8	175/225	225.5/252.8	674.5/ 701.8	150/175	115	40
110, 112	230-60	207	253	4/4	241.0/244.9	400/350	372.0/417.0	—	300/300	115	40
	200-60	187	220	4/4	264.9/269.8	450/400	426.5/476.3	—	350/350	115	40
	460-60	414	506	4/4	120.9/122.4	200/175	186.0/208.5	557.0/ 579.5	150/150	115	40
	575-60	518	633	4/4	92.5/ 94.4	150/125	148.6/166.6	445.6/ 463.6	110/110	115	40
	380-60	342	418	4/4	140.2/143.8	225/225	225.5/252.8	674.5/ 701.8	175/175	115	40
120, 122	230-60	207	253	4/4	241.0/286.0	400/450	372.0/417.0	—	300/350	115	40
	200-60	187	220	4/4	264.9/314.7	450/500	426.5/476.3	—	350/400	115	40
	460-60	414	506	4/4	120.0/142.5	200/225	186.0/208.5	557.0/ 579.5	150/175	115	40
	575-60	518	633	4/4	92.5/110.5	150/175	148.6/166.6	445.6/ 463.6	110/150	115	40
	380-60	342	418	4/4	140.2/167.5	225/250	225.5/252.8	674.5/ 701.8	175/200	115	40
140, 142	230-60	207	253	6/4	370.0/244.9	600/350	632.0/417.0	—	450/300	115	40
	200-60	187	220	6/4	407.2/269.8	700/400	724.8/476.3	—	500/350	115	40
	460-60	414	506	6/4	185.0/122.4	300/175	316.0/208.5	948.0/ 579.5	225/150	115	40
	575-60	518	633	6/4	141.9/ 94.4	225/125	252.4/166.6	758.4/ 463.6	175/110	115	40
	380-60	342	418	6/4	215.1/143.8	350/225	382.8/252.8	1147.8/ 701.8	300/175	115	40
160, 162	230-60	207	253	6/4	423.5/286.0	700/450	800.0/417.0	—	600/350	115	40
	200-60	187	220	6/4	465.6/314.7	800/500	918.8/476.3	—	600/400	115	40
	460-60	414	506	6/4	211.3/142.5	350/225	400.0/208.5	1208.0/ 579.5	250/175	115	40
	575-60	518	633	6/4	162.2/110.5	250/175	320.4/166.6	966.4/ 463.6	200/150	115	40
	380-60	342	418	6/4	246.0/167.5	400/250	483.8/252.8	1462.8/ 701.8	300/200	115	40
180, 182	230-60	207	253	6/6	—	—	—	—	—	115	60
	200-60	187	220	6/6	—	—	—	—	—	115	60
	460-60	414	506	6/6	—	—	—	—	—	115	60
	575-60	518	633	6/6	—	—	—	—	—	115	60
	380-60	342	418	6/6	—	—	—	—	—	115	60
200, 202	230-60	207	253	6/6	—	—	—	—	—	115	60
	200-60	187	220	6/6	—	—	—	—	—	115	60
	460-60	414	506	6/6	—	—	—	—	—	115	60
	575-60	518	633	6/6	—	—	—	—	—	115	60
	380-60	342	418	6/6	—	—	—	—	—	115	60
220, 222	230-60	207	253	7/6	—	—	—	—	—	115	60
	200-60	187	220	7/6	—	—	—	—	—	115	60
	460-60	414	506	7/6	—	—	—	—	—	115	60
	575-60	518	633	7/6	—	—	—	—	—	115	60
	380-60	342	418	7/6	—	—	—	—	—	115	60
240, 242	230-60	207	253	7/6	—	—	—	—	—	115	60
	200-60	187	220	7/6	—	—	—	—	—	115	60
	460-60	414	506	7/6	—	—	—	—	—	115	60
	575-60	518	633	7/6	—	—	—	—	—	115	60
	380-60	342	418	7/6	—	—	—	—	—	115	60
260, 262	460-60	414	506	9/6	—	—	—	—	—	115	60
	575-60	518	633	9/6	—	—	—	—	—	115	60
	380-60	342	418	9/6	—	—	—	—	—	115	60
280, 282	460-60	414	506	9/7	—	—	—	—	—	115	60
	575-60	518	633	9/7	—	—	—	—	—	115	60
	380-60	342	418	9/7	—	—	—	—	—	115	60
300, 302	460-60	414	506	10/6	—	—	—	—	—	115	60
	575-60	518	633	10/6	—	—	—	—	—	115	60
	380-60	342	418	10/6	—	—	—	—	—	115	60
325, 327	460-60	414	506	9/9	—	—	—	—	—	115	60
	575-60	518	633	9/9	—	—	—	—	—	115	60
	380-60	342	418	9/9	—	—	—	—	—	115	60
350, 352	460-60	414	506	9/9	—	—	—	—	—	115	60
	575-60	518	633	9/9	—	—	—	—	—	115	60
	380-60	342	418	9/9	—	—	—	—	—	115	60

LEGEND

- ICF — Instantaneous Current Flow
- MCA — Minimum Circuit Amps
- MOCP — Maximum Overcurrent Protection
- WD — Wye-Delta
- XL — Across-the-Line

NOTES:

- Units are suitable for use on electrical systems where voltage supplied to the unit terminals is not below or above the listed minimum and maximum limits. Maximum allowable phase imbalance is: voltage, 2%; amps 10%.
- Cooler heater (where applicable) is wired into the control circuit so it is always operable as long as the control power supply disconnect is on, even if any safety device is open.
- For MCA that is less than or equal to 380 amps, 3 conductors are required.
For MCA between 381-760 amps, 6 conductors are required.
For MCA between 761-1140 amps, 9 conductors are required.
For MCA between 1141-1520 amps, 12 conductors are required.
Calculation of conductors required is based on 75 C copper wire.

- Wiring for main field supply must be rated 75 C minimum. Use copper for all units.
 - Incoming wire size range for the terminal block is no. 4 AWG (American Wire Gage) to 500 kcmil.
 - Incoming wire size range of non-fused disconnect with MCA up to 599.9 amps is 3/0 to 500 kcmil.
 - Incoming wire size range of non-fused disconnect with MCA from 600 to 799.9 amps is 1/0 to 500 kcmil.
 - Incoming wire size range of non-fused disconnect with MCA from 800 to 1199.9 amps is 250 kcmil to 500 kcmil.
- Data provided as circuit 1/circuit 2 where there are two circuits.
- Standard condenser fan motors are not used with sizes sizes 30XA401-501. These sizes use high ambient temperature condenser fans.



SINGLE POINT (HIGH AMBIENT OPTION)

UNIT 30XA	UNIT VOLTAGE			NUMBER OF COND FANS	NO HYDRONIC PACKAGE				5 HP PUMP, 3450 RPM					7.5 HP PUMP, 3450 RPM					CONTROL CIRCUIT		
	V-Hz (3 Ph)	Supplied			MCA	MOCP	ICF		Rec Fuse Size	MCA	MOCP	ICF		Rec Fuse Size	MCA	MOCP	ICF		Rec Fuse Size	Voltage 1 PH, 60 Hz	MCA and MOCP
		Min	Max				WD	XL				WD	XL				WD	XL			
140, 142	230-60	207	253	10	562.0	800	838.9	—	700	578.0	800	854.9	—	700	585.2	800	862.1	—	700	115	40
	200-60	187	220	10	618.8	800	952.8	—	700	636.5	800	970.5	—	800	644.4	800	978.5	—	800	115	40
	460-60	414	506	10	281.0	400	419.5	1051.5	350	289.0	400	427.5	1059.5	350	292.6	400	431.1	1063.1	350	115	40
	575-60	518	633	10	216.3	300	332.5	838.5	250	222.7	300	338.9	844.9	250	225.6	300	341.8	847.8	250	115	40
	380-60	342	418	10	328.3	450	504.6	1269.6	400	338.0	450	514.3	1279.3	400	342.3	450	518.7	1283.7	400	115	40
160, 162	230-60	207	253	10	642.7	800	1036.7	—	800	658.7	800	1052.7	—	800	665.9	800	1059.9	—	800	115	40
	200-60	187	220	10	706.9	1000	1179.4	—	800	724.5	1000	1197.1	—	1000	732.5	1000	1205.0	—	1000	115	40
	460-60	414	506	10	320.5	450	518.0	1326.0	400	328.5	450	526.0	1334.0	400	332.1	450	529.6	1337.6	400	115	40
	575-60	518	633	10	247.2	350	412.1	1058.1	300	253.6	350	418.5	1064.5	300	256.5	350	421.4	1067.4	300	115	40
	380-60	342	418	10	374.9	500	622.8	1601.8	450	384.6	500	632.5	1611.5	450	388.9	500	636.8	1615.8	450	115	40
180, 182	230-60	207	253	12	703.9	800	980.8	—	800	—	—	—	—	—	—	—	—	—	—	115	60
	200-60	187	220	12	775.0	1000	1109.1	—	1000	—	—	—	—	—	—	—	—	—	—	115	60
	460-60	414	506	12	351.9	450	490.4	1122.4	400	—	—	—	—	—	—	—	—	—	—	115	60
	575-60	518	633	12	271.1	350	387.3	893.3	300	—	—	—	—	—	—	—	—	—	—	115	60
	380-60	342	418	12	410.8	500	587.2	1352.2	450	—	—	—	—	—	—	—	—	—	—	115	60
200, 202	230-60	207	253	12	795.6	1000	1189.6	—	1000	—	—	—	—	—	—	—	—	—	—	115	60
	200-60	187	220	12	875.0	1200	1347.5	—	1000	—	—	—	—	—	—	—	—	—	—	115	60
	460-60	414	506	12	396.9	500	594.4	1402.4	450	—	—	—	—	—	—	—	—	—	—	115	60
	575-60	518	633	12	305.8	400	470.7	1116.7	350	—	—	—	—	—	—	—	—	—	—	115	60
	380-60	342	418	12	463.8	600	711.7	1690.7	600	—	—	—	—	—	—	—	—	—	—	115	60
220, 222	230-60	207	253	13	876.7	1200	1200.4	—	1000	—	—	—	—	—	—	—	—	—	—	115	60
	200-60	187	220	13	964.6	1200	1359.4	—	1200	—	—	—	—	—	—	—	—	—	—	115	60
	460-60	414	506	13	438.0	600	599.8	1407.8	500	—	—	—	—	—	—	—	—	—	—	115	60
	575-60	518	633	13	337.6	450	475.0	1121.0	400	—	—	—	—	—	—	—	—	—	—	115	60
	380-60	342	418	13	511.5	700	718.3	1697.3	600	—	—	—	—	—	—	—	—	—	—	115	60
240, 242	230-60	207	253	13	933.0	1200	1256.7	—	1200	—	—	—	—	—	—	—	—	—	—	115	60
	200-60	187	220	13	1026.7	1200	1421.6	—	1200	—	—	—	—	—	—	—	—	—	—	115	60
	460-60	414	506	13	466.5	600	628.3	1436.3	600	—	—	—	—	—	—	—	—	—	—	115	60
	575-60	518	633	13	359.5	450	497.0	1143.0	400	—	—	—	—	—	—	—	—	—	—	115	60
	380-60	342	418	13	544.4	700	751.2	1730.2	600	—	—	—	—	—	—	—	—	—	—	115	60
260, 262	460-60	414	506	15	529.1	700	806.6	2028.6	600	—	—	—	—	—	—	—	—	—	—	115	60
	575-60	518	633	15	407.4	500	639.7	1617.7	500	—	—	—	—	—	—	—	—	—	—	115	60
	380-60	342	418	15	616.7	800	969.3	2448.3	700	—	—	—	—	—	—	—	—	—	—	115	60
280, 282	460-60	414	506	16	563.0	800	840.5	2062.5	700	—	—	—	—	—	—	—	—	—	—	115	60
	575-60	518	633	16	433.6	600	665.9	1643.9	500	—	—	—	—	—	—	—	—	—	—	115	60
	380-60	342	418	16	656.2	800	1008.8	2487.8	800	—	—	—	—	—	—	—	—	—	—	115	60
300, 302	460-60	414	506	16	619.6	800	840.5	2062.5	700	—	—	—	—	—	—	—	—	—	—	115	60
	575-60	518	633	16	476.7	600	665.9	1643.9	600	—	—	—	—	—	—	—	—	—	—	115	60
	380-60	342	418	16	722.3	1000	1008.8	2487.8	1000	—	—	—	—	—	—	—	—	—	—	115	60
325, 327	460-60	414	506	18	638.1	800	915.6	2137.6	700	—	—	—	—	—	—	—	—	—	—	115	60
	575-60	518	633	18	491.2	600	723.5	1701.5	600	—	—	—	—	—	—	—	—	—	—	115	60
	380-60	342	418	18	743.0	1000	1095.6	2574.6	1000	—	—	—	—	—	—	—	—	—	—	115	60
350, 352	460-60	414	506	18	694.6	800	915.6	2137.6	800	—	—	—	—	—	—	—	—	—	—	115	60
	575-60	518	633	18	534.2	700	723.5	1701.5	600	—	—	—	—	—	—	—	—	—	—	115	60
	380-60	342	418	18	809.1	1000	1095.6	2574.6	1000	—	—	—	—	—	—	—	—	—	—	115	60
401	460-60	414	506	20	853.6	1200	1018.6	2299.6	1000	—	—	—	—	—	—	—	—	—	—	115	60
	575-60	518	633	20	671.6	800	802.6	1825.6	800	—	—	—	—	—	—	—	—	—	—	115	60
	380-60	342	418	20	1017.7	1200	1219.6	2773.6	1200	—	—	—	—	—	—	—	—	—	—	115	60
451	460-60	414	506	22	864.4	1200	1029.4	2310.4	1000	—	—	—	—	—	—	—	—	—	—	115	60
	575-60	518	633	22	680.2	800	811.2	1834.2	800	—	—	—	—	—	—	—	—	—	—	115	60
	380-60	342	418	22	1030.8	1200	1232.7	2786.7	1200	—	—	—	—	—	—	—	—	—	—	115	60
476	460-60	414	506	22	861.5	1200	1055.4	2336.4	1000	—	—	—	—	—	—	—	—	—	—	115	60
	575-60	518	633	22	687.2	800	840.5	1863.5	800	—	—	—	—	—	—	—	—	—	—	115	60
	380-60	342	418	22	1046.2	1200	1280.1	2834.1	1200	—	—	—	—	—	—	—	—	—	—	115	60
501	460-60	414	506	26	912.9	1200	1077.9	2358.9	1200	—	—	—	—	—	—	—	—	—	—	115	60
	575-60	518	633	26	729.1	1000	860.1	1883.1	1000	—	—	—	—	—	—	—	—	—	—	115	60
	380-60	342	418	26	—	—	—	—	—	—	—	—	—	—	—	—	—	—	—	115	60

LEGEND

- ICF — Instantaneous Current Flow
- MCA — Minimum Circuit Amps
- MOCP — Maximum Overcurrent Protection
- WD — Wye-Delta
- XL — Across-the-Line

NOTES:

- Units are suitable for use on electrical systems where voltage supplied to the unit terminals is not below or above the listed minimum and maximum limits. Maximum allowable phase imbalance is: voltage, 2%; amps 10%.
- Cooler heater (where applicable) is wired into the control circuit so it is always operable as long as the control power supply disconnect is on, even if any safety device is open.
- For MCA that is less than or equal to 380 amps, 3 conductors are required.
For MCA between 381-760 amps, 6 conductors are required.
For MCA between 761-1140 amps, 9 conductors are required.
For MCA between 1141-1520 amps, 12 conductors are required.
Calculation of conductors required is based on 75 C copper wire.

- Wiring for main field supply must be rated 75 C minimum. Use copper for all units.
 - Incoming wire size range for the terminal block is no. 4 AWG (American Wire Gauge) to 500 kcmil.
 - Incoming wire size range of non-fused disconnect with MCA up to 599.9 amps is 3/0 to 500 kcmil.
 - Incoming wire size range of non-fused disconnect with MCA from 600 to 799.9 amps is 1/0 to 500 kcmil.
 - Incoming wire size range of non-fused disconnect with MCA from 800 to 1199.9 amps is 250 kcmil to 500 kcmil.
- Data provided as circuit 1/circuit 2 where there are two circuits.
- High ambient fan motors are not available on unit sizes 30XA080-122.



Electrical data (cont)



SINGLE POINT (HIGH AMBIENT OPTION) (cont)

UNIT 30XA	UNIT VOLTAGE			NUMBER OF COND FANS	10 HP PUMP, 3450 RPM					15 HP PUMP, 3450 RPM					CONTROL CIRCUIT	
	V-Hz (3 Ph)	Supplied			MCA	MOCP	ICF		Rec Fuse Size	MCA	MOCP	ICF		Rec Fuse Size	Voltage 1 PH, 60 Hz	MCA and MOCP
		Min	Max				WD	XL				WD	XL			
140, 142	230-60	207	253	10	592.4	800	869.3	—	700	607.0	800	883.9	—	700	115	40
	200-60	187	220	10	652.4	800	986.5	—	800	668.6	800	1002.6	—	800	115	40
	460-60	414	506	10	296.2	400	434.7	1066.7	350	303.5	400	442.0	1074.0	350	115	40
	575-60	518	633	10	228.4	300	344.6	850.6	300	234.3	300	350.5	856.5	300	115	40
	380-60	342	418	10	346.7	450	523.0	1288.0	400	355.5	500	531.9	1296.9	400	115	40
160, 162	230-60	207	253	10	673.1	800	1067.1	—	800	687.7	800	1081.7	—	800	115	40
	200-60	187	220	10	740.5	1000	1213.0	—	1000	756.6	1000	1229.1	—	1000	115	40
	460-60	414	506	10	335.7	450	533.2	1341.2	400	343.0	450	540.5	1348.5	400	115	40
	575-60	518	633	10	259.4	350	424.3	1070.3	300	265.2	350	430.1	1076.1	300	115	40
	380-60	342	418	10	393.3	500	641.2	1620.2	450	402.1	500	650.0	1629.0	450	115	40
180, 182	230-60	207	253	12	—	—	—	—	—	—	—	—	—	—	115	60
	200-60	187	220	12	—	—	—	—	—	—	—	—	—	—	115	60
	460-60	414	506	12	—	—	—	—	—	—	—	—	—	—	115	60
	575-60	518	633	12	—	—	—	—	—	—	—	—	—	—	115	60
	380-60	342	418	12	—	—	—	—	—	—	—	—	—	—	115	60
200, 202	230-60	207	253	12	—	—	—	—	—	—	—	—	—	—	115	60
	200-60	187	220	12	—	—	—	—	—	—	—	—	—	—	115	60
	460-60	414	506	12	—	—	—	—	—	—	—	—	—	—	115	60
	575-60	518	633	12	—	—	—	—	—	—	—	—	—	—	115	60
	380-60	342	418	12	—	—	—	—	—	—	—	—	—	—	115	60
220, 222	230-60	207	253	13	—	—	—	—	—	—	—	—	—	—	115	60
	200-60	187	220	13	—	—	—	—	—	—	—	—	—	—	115	60
	460-60	414	506	13	—	—	—	—	—	—	—	—	—	—	115	60
	575-60	518	633	13	—	—	—	—	—	—	—	—	—	—	115	60
	380-60	342	418	13	—	—	—	—	—	—	—	—	—	—	115	60
240, 242	230-60	207	253	13	—	—	—	—	—	—	—	—	—	—	115	60
	200-60	187	220	13	—	—	—	—	—	—	—	—	—	—	115	60
	460-60	414	506	13	—	—	—	—	—	—	—	—	—	—	115	60
	575-60	518	633	13	—	—	—	—	—	—	—	—	—	—	115	60
	380-60	342	418	13	—	—	—	—	—	—	—	—	—	—	115	60
260, 262	460-60	414	506	15	—	—	—	—	—	—	—	—	—	—	115	60
	575-60	518	633	15	—	—	—	—	—	—	—	—	—	—	115	60
	380-60	342	418	15	—	—	—	—	—	—	—	—	—	—	115	60
280, 282	460-60	414	506	16	—	—	—	—	—	—	—	—	—	—	115	60
	575-60	518	633	16	—	—	—	—	—	—	—	—	—	—	115	60
	380-60	342	418	16	—	—	—	—	—	—	—	—	—	—	115	60
300, 302	460-60	414	506	16	—	—	—	—	—	—	—	—	—	—	115	60
	575-60	518	633	16	—	—	—	—	—	—	—	—	—	—	115	60
	380-60	342	418	16	—	—	—	—	—	—	—	—	—	—	115	60
325, 327	460-60	414	506	18	—	—	—	—	—	—	—	—	—	—	115	60
	575-60	518	633	18	—	—	—	—	—	—	—	—	—	—	115	60
	380-60	342	418	18	—	—	—	—	—	—	—	—	—	—	115	60
350, 352	460-60	414	506	18	—	—	—	—	—	—	—	—	—	—	115	60
	575-60	518	633	18	—	—	—	—	—	—	—	—	—	—	115	60
	380-60	342	418	18	—	—	—	—	—	—	—	—	—	—	115	60
401	460-60	414	506	20	—	—	—	—	—	—	—	—	—	—	115	60
	575-60	518	633	20	—	—	—	—	—	—	—	—	—	—	115	60
	380-60	342	418	20	—	—	—	—	—	—	—	—	—	—	115	60
451	460-60	414	506	22	—	—	—	—	—	—	—	—	—	—	115	60
	575-60	518	633	22	—	—	—	—	—	—	—	—	—	—	115	60
	380-60	342	418	22	—	—	—	—	—	—	—	—	—	—	115	60
476	460-60	414	506	22	—	—	—	—	—	—	—	—	—	—	115	60
	575-60	518	633	22	—	—	—	—	—	—	—	—	—	—	115	60
	380-60	342	418	22	—	—	—	—	—	—	—	—	—	—	115	60
501	460-60	414	506	26	—	—	—	—	—	—	—	—	—	—	115	60
	575-60	518	633	26	—	—	—	—	—	—	—	—	—	—	115	60
	380-60	342	418	26	—	—	—	—	—	—	—	—	—	—	115	60

LEGEND

- ICF — Instantaneous Current Flow
- MCA — Minimum Circuit Amps
- MOCP — Maximum Overcurrent Protection
- WD — Wye-Delta
- XL — Across-the-Line

NOTES:

1. Units are suitable for use on electrical systems where voltage supplied to the unit terminals is not below or above the listed minimum and maximum limits. Maximum allowable phase imbalance is: voltage, 2%; amps 10%.
2. Cooler heater (where applicable) is wired into the control circuit so it is always operable as long as the control power supply disconnect is on, even if any safety device is open.
3. For MCA that is less than or equal to 380 amps, 3 conductors are required.
For MCA between 381-760 amps, 6 conductors are required.
For MCA between 761-1140 amps, 9 conductors are required.
For MCA between 1141-1520 amps, 12 conductors are required.
Calculation of conductors required is based on 75 C copper wire.

4. Wiring for main field supply must be rated 75 C minimum. Use copper for all units.
 - a. Incoming wire size range for the terminal block is no. 4 AWG (American Wire Gage) to 500 kcmil.
 - b. Incoming wire size range of non-fused disconnect with MCA up to 599.9 amps is 3/0 to 500 kcmil.
 - c. Incoming wire size range of non-fused disconnect with MCA from 600 to 799.9 amps is 1/0 to 500 kcmil.
 - d. Incoming wire size range of non-fused disconnect with MCA from 800 to 1199.9 amps is 250 kcmil to 500 kcmil.
5. Data provided as circuit 1/circuit 2 where there are two circuits.
6. High ambient fan motors are not available on unit sizes 30XA080-122.



DUAL POINT (HIGH AMBIENT OPTION)

UNIT 30XA	UNIT VOLTAGE			NUMBER OF COND FANS	NO HYDRONIC PACKAGE						5 HP PUMP, 3450 RPM						CONTROL CIRCUIT	
	V-Hz (3 Ph)	Supplied			MCA	MOCP	ICF		Rec Fuse Size	MCA	MOCP	ICF		Rec Fuse Size	Voltage 1 PH, 60 Hz	MCA and MOCP		
		Min	Max				WD	XL				WD	XL					
140, 142	230-60	207	253	6/4	383.8/211.9	600/ 300	660.8/391.2	—	450/250	383.8/227.9	600/350	660.8/407.2	—	450/300	115	40		
	200-60	187	220	6/4	422.6/233.3	700/ 350	756.7/447.8	—	500/300	422.6/251.0	700/350	756.7/465.5	—	500/300	115	40		
	460-60	414	506	6/4	191.9/105.9	300/ 150	330.4/195.6	962.4/ 566.6	225/125	191.9/113.9	300/175	330.4/203.6	962.4/574.6	225/150	115	40		
	575-60	518	633	6/4	147.7/ 81.4	225/ 125	263.9/156.3	769.9/ 453.3	175/100	147.7/ 87.8	225/125	263.9/162.7	769.9/459.7	175/110	115	40		
380-60	342	418	6/4	223.9/124.0	350/ 200	400.2/237.1	1165.2/ 686.1	300/150	223.9/133.7	350/200	400.2/246.8	1165.2/695.8	300/175	115	40			
160, 162	230-60	207	253	6/4	434.8/249.1	700/ 400	828.8/391.2	—	600/300	434.8/265.1	700/400	828.8/407.2	—	600/350	115	40		
	200-60	187	220	6/4	478.1/273.9	800/ 450	950.7/447.8	—	600/350	478.1/291.6	800/450	950.7/465.5	—	600/350	115	40		
	460-60	414	506	6/4	216.9/124.1	350/ 200	414.4/195.6	1222.4/ 566.6	300/150	216.9/132.1	350/200	414.4/203.6	1222.4/574.6	300/175	115	40		
	575-60	518	633	6/4	167.0/ 95.9	250/ 150	331.9/156.3	977.9/ 453.3	200/125	167.0/102.3	250/150	331.9/162.7	977.9/459.7	200/125	115	40		
380-60	342	418	6/4	253.3/145.4	400/ 225	501.2/237.1	1480.2/ 686.1	300/175	253.3/155.1	400/250	501.2/246.8	1480.2/695.8	300/200	115	40			
180, 182	230-60	207	253	6/6	383.8/383.8	600/ 600	660.8/660.8	—	450/450	—	—	—	—	—	115	60		
	200-60	187	220	6/6	422.6/422.6	700/ 700	756.7/756.7	—	500/500	—	—	—	—	—	115	60		
	460-60	414	506	6/6	191.9/191.9	300/ 300	330.4/330.4	962.4/ 962.4	225/225	—	—	—	—	—	115	60		
	575-60	518	633	6/6	147.7/147.7	225/ 225	263.9/263.9	769.9/ 769.9	175/175	—	—	—	—	—	115	60		
380-60	342	418	6/6	223.9/223.9	350/ 350	400.2/400.2	1165.2/1165.2	300/300	—	—	—	—	—	115	60			
200, 202	230-60	207	253	6/6	434.8/434.8	700/ 700	828.8/828.8	—	600/600	—	—	—	—	—	115	60		
	200-60	187	220	6/6	478.1/478.1	800/ 800	950.7/950.7	—	600/600	—	—	—	—	—	115	60		
	460-60	414	506	6/6	216.9/216.9	350/ 350	414.4/414.4	1222.4/1222.4	300/300	—	—	—	—	—	115	60		
	575-60	518	633	6/6	167.0/167.0	250/ 250	331.9/331.9	977.9/ 977.9	200/200	—	—	—	—	—	115	60		
380-60	342	418	6/6	253.3/253.3	400/ 400	501.2/501.2	1480.2/1480.2	300/300	—	—	—	—	—	115	60			
220, 222	230-60	207	253	7/6	515.9/434.8	800/ 700	839.6/828.8	—	700/600	—	—	—	—	—	115	60		
	200-60	187	220	7/6	567.8/478.1	800/ 800	962.6/950.7	—	700/600	—	—	—	—	—	115	60		
	460-60	414	506	7/6	258.0/216.9	400/ 350	419.8/414.4	1227.8/1222.4	350/300	—	—	—	—	—	115	60		
	575-60	518	633	7/6	198.8/167.0	300/ 250	336.2/331.9	982.2/ 977.9	250/200	—	—	—	—	—	115	60		
380-60	342	418	7/6	301.0/253.3	500/ 400	507.8/501.2	1486.8/1480.2	400/300	—	—	—	—	—	115	60			
240, 242	230-60	207	253	7/6	515.9/505.1	800/ 800	839.6/828.8	—	700/600	—	—	—	—	—	115	60		
	200-60	187	220	7/6	567.8/555.8	800/ 800	962.6/950.7	—	700/700	—	—	—	—	—	115	60		
	460-60	414	506	7/6	258.0/252.6	400/ 400	419.8/414.4	1227.8/1222.4	350/300	—	—	—	—	—	115	60		
	575-60	518	633	7/6	198.8/194.5	300/ 300	336.2/331.9	982.2/ 977.9	250/250	—	—	—	—	—	115	60		
380-60	342	418	7/6	301.0/294.5	500/ 450	507.8/501.2	1486.8/1480.2	400/350	—	—	—	—	—	115	60			
260, 262	460-60	414	506	9/6	349.1/216.9	500/ 350	626.6/414.4	1848.6/1222.4	450/300	—	—	—	—	—	115	60		
	575-60	518	633	9/6	268.6/167.0	450/ 250	500.9/331.9	1478.9/ 977.9	350/200	—	—	—	—	—	115	60		
	380-60	342	418	9/6	406.2/253.3	600/ 400	758.8/501.2	2237.8/1480.2	500/300	—	—	—	—	—	115	60		
	460-60	414	506	9/7	349.1/258.0	500/ 400	626.6/419.8	1848.6/1227.8	450/350	—	—	—	—	—	115	60		
575-60	518	633	9/7	268.6/198.8	450/ 300	500.9/336.2	1478.9/ 982.2	350/250	—	—	—	—	—	115	60			
380-60	342	418	9/7	406.2/301.0	600/ 500	758.8/507.8	2237.8/1486.8	500/400	—	—	—	—	—	115	60			
300, 302	460-60	414	506	10/6	411.0/252.6	600/ 400	632.0/414.4	1854.0/1222.4	500/300	—	—	—	—	—	115	60		
	575-60	518	633	10/6	315.9/194.5	500/ 300	505.2/331.9	1483.2/ 977.9	400/250	—	—	—	—	—	115	60		
	380-60	342	418	10/6	478.9/294.5	800/ 450	765.4/501.2	2244.4/1480.2	600/350	—	—	—	—	—	115	60		
	460-60	414	506	9/9	349.1/349.1	500/ 500	626.6/626.6	1848.6/1848.6	450/450	—	—	—	—	—	115	60		
575-60	518	633	9/9	268.6/268.6	450/ 450	500.9/500.9	1478.9/1478.9	350/350	—	—	—	—	—	115	60			
380-60	342	418	9/9	406.2/406.2	600/ 600	758.8/758.8	2237.8/2237.8	500/500	—	—	—	—	—	115	60			
350, 352	460-60	414	506	9/9	405.6/349.1	600/ 500	626.6/626.6	1848.6/1848.6	500/450	—	—	—	—	—	115	60		
	575-60	518	633	9/9	311.6/268.6	500/ 450	500.9/500.9	1478.9/1478.9	400/350	—	—	—	—	—	115	60		
	380-60	342	418	9/9	472.4/406.2	800/ 600	758.8/758.8	2237.8/2237.8	600/500	—	—	—	—	—	115	60		
	460-60	414	506	11/9	448.9/405.6	700/ 600	684.4/626.6	1965.4/1848.6	600/500	—	—	—	—	—	115	60		
575-60	518	633	11/9	356.9/311.6	600/ 500	545.5/500.9	1568.5/1478.9	450/400	—	—	—	—	—	115	60			
380-60	342	418	11/9	544.8/472.4	800/ 800	829.5/758.5	2383.9/2237.8	700/600	—	—	—	—	—	115	60			
451	460-60	414	506	13/9	530.2/405.6	800/ 600	695.2/626.6	1976.2/1848.6	700/500	—	—	—	—	—	115	60		
	575-60	518	633	13/9	423.2/311.6	700/ 500	554.2/500.9	1577.2/1478.9	500/400	—	—	—	—	—	115	60		
	380-60	342	418	13/9	641.1/472.4	1000/ 800	843.0/758.8	2397.0/2237.8	800/600	—	—	—	—	—	115	60		
	460-60	414	506	11/11	490.5/448.9	800/ 700	684.4/684.4	1965.4/1965.4	600/600	—	—	—	—	—	115	60		
575-60	518	633	11/11	392.1/356.9	600/ 600	545.5/545.5	1568.5/1568.5	500/450	—	—	—	—	—	115	60			
380-60	342	418	11/11	596.0/544.8	1000/ 800	829.9/829.9	2383.9/2383.9	800/700	—	—	—	—	—	115	60			
501	460-60	414	506	14/12	535.6/495.9	800/ 800	700.6/689.8	1981.6/1970.8	700/600	—	—	—	—	—	115	60		
	575-60	518	633	14/12	427.5/396.5	700/ 600	558.5/549.8	1581.5/1572.8	600/500	—	—	—	—	—	115	60		
	380-60	342	418	14/12	647.6/602.6	1000/1000	849.5/836.4	2403.5/2390.4	800/800	—	—	—	—	—	115	60		
	460-60	414	506	11/11	490.5/448.9	800/ 700	684.4/684.4	1965.4/1965.4	600/600	—	—	—	—	—	115	60		

LEGEND

- ICF — Instantaneous Current Flow
- MCA — Minimum Circuit Amps
- MOCP — Maximum Overcurrent Protection
- WD — Wye-Delta
- XL — Across-the-Line

NOTES:

1. Units are suitable for use on electrical systems where voltage supplied to the unit terminals is not below or above the listed minimum and maximum limits. Maximum allowable phase imbalance is: voltage, 2%; amps 10%.
2. Cooler heater (where applicable) is wired into the control circuit so it is always operable as long as the control power supply disconnect is on, even if any safety device is open.
3. For MCA that is less than or equal to 380 amps, 3 conductors are required.
For MCA between 381-760 amps, 6 conductors are required.
For MCA between 761-1140 amps, 9 conductors are required.
For MCA between 1141-1520 amps, 12 conductors are required.
Calculation of conductors required is based on 75 C copper wire.

4. Wiring for main field supply must be rated 75 C minimum. Use copper for all units.
 - a. Incoming wire size range for the terminal block is no. 4 AWG (American Wire Gauge) to 500 kcmil.
 - b. Incoming wire size range of non-fused disconnect with MCA up to 599.9 amps is 3/0 to 500 kcmil.
 - c. Incoming wire size range of non-fused disconnect with MCA from 600 to 799.9 amps is 1/0 to 500 kcmil.
 - d. Incoming wire size range of non-fused disconnect with MCA from 800 to 1199.9 amps is 250 kcmil to 500 kcmil.
5. Data provided as circuit 1/circuit 2 where there are two circuits.
6. High ambient fan motors are not available on unit sizes 30XA080-122.



Electrical data (cont)



DUAL POINT (HIGH AMBIENT OPTION) (cont)

UNIT 30XA	UNIT VOLTAGE			NUMBER OF COND FANS	7.5 HP PUMP, 3450 RPM						10 HP PUMP, 3450 RPM						CONTROL CIRCUIT	
	V-Hz (3 Ph)	Supplied			MCA	MOCP	ICF		Rec Fuse Size	MCA	MOCP	ICF		Rec Fuse Size	Voltage 1 PH, 60 Hz	MCA and MOCP		
		Min	Max				WD	XL				WD	XL					
140, 142	230-60	207	253	6/4	383.8/235.1	600/350	660.8/414.4	—	450/300	383.8/242.3	600/350	660.8/421.6	—	450/300	115	40		
	200-60	187	220	6/4	422.6/259.0	700/400	756.7/473.4	—	500/300	422.6/266.9	700/400	756.7/481.4	—	500/350	115	40		
	460-60	414	506	6/4	191.9/117.5	300/175	330.4/207.2	962.4/578.2	225/150	191.9/121.1	300/175	330.4/210.8	962.4/581.8	225/150	115	40		
	575-60	518	633	6/4	147.7/ 90.7	225/125	263.9/165.6	769.9/462.6	175/110	147.7/ 93.5	225/125	263.9/168.4	769.9/465.4	175/110	115	40		
	380-60	342	418	6/4	223.9/138.0	350/200	400.2/251.2	1165.2/700.2	300/175	223.9/142.4	350/200	400.2/255.5	1165.2/704.5	300/175	115	40		
160, 162	230-60	207	253	6/4	434.8/272.3	700/400	828.8/414.4	—	600/350	434.8/279.5	700/400	828.8/421.6	—	600/350	115	40		
	200-60	187	220	6/4	478.1/299.6	800/450	950.7/473.4	—	600/350	478.1/307.6	800/450	950.7/481.4	—	600/400	115	40		
	460-60	414	506	6/4	216.9/135.7	350/200	414.4/207.2	1222.4/578.2	300/175	216.9/139.3	350/200	414.4/210.8	1222.4/581.8	300/175	115	40		
	575-60	518	633	6/4	167.0/105.2	250/150	331.9/165.6	977.9/462.6	200/125	167.0/108.1	250/150	331.9/168.4	977.9/465.4	200/125	115	40		
	380-60	342	418	6/4	253.3/159.5	400/250	501.2/251.2	1480.2/700.2	300/200	253.3/163.8	400/250	501.2/255.5	1480.2/704.5	300/200	115	40		
180, 182	230-60	207	253	6/6	—	—	—	—	—	—	—	—	—	—	115	60		
	200-60	187	220	6/6	—	—	—	—	—	—	—	—	—	—	115	60		
	460-60	414	506	6/6	—	—	—	—	—	—	—	—	—	—	115	60		
	575-60	518	633	6/6	—	—	—	—	—	—	—	—	—	—	115	60		
	380-60	342	418	6/6	—	—	—	—	—	—	—	—	—	—	115	60		
200, 202	230-60	207	253	6/6	—	—	—	—	—	—	—	—	—	—	115	60		
	200-60	187	220	6/6	—	—	—	—	—	—	—	—	—	—	115	60		
	460-60	414	506	6/6	—	—	—	—	—	—	—	—	—	—	115	60		
	575-60	518	633	6/6	—	—	—	—	—	—	—	—	—	—	115	60		
	380-60	342	418	6/6	—	—	—	—	—	—	—	—	—	—	115	60		
220, 222	230-60	207	253	7/6	—	—	—	—	—	—	—	—	—	—	115	60		
	200-60	187	220	7/6	—	—	—	—	—	—	—	—	—	—	115	60		
	460-60	414	506	7/6	—	—	—	—	—	—	—	—	—	—	115	60		
	575-60	518	633	7/6	—	—	—	—	—	—	—	—	—	—	115	60		
	380-60	342	418	7/6	—	—	—	—	—	—	—	—	—	—	115	60		
240, 242	230-60	207	253	7/6	—	—	—	—	—	—	—	—	—	—	115	60		
	200-60	187	220	7/6	—	—	—	—	—	—	—	—	—	—	115	60		
	460-60	414	506	7/6	—	—	—	—	—	—	—	—	—	—	115	60		
	575-60	518	633	7/6	—	—	—	—	—	—	—	—	—	—	115	60		
	380-60	342	418	7/6	—	—	—	—	—	—	—	—	—	—	115	60		
260, 262	460-60	414	506	9/6	—	—	—	—	—	—	—	—	—	—	115	60		
	575-60	518	633	9/6	—	—	—	—	—	—	—	—	—	—	115	60		
	380-60	342	418	9/6	—	—	—	—	—	—	—	—	—	—	115	60		
280, 282	460-60	414	506	9/7	—	—	—	—	—	—	—	—	—	—	115	60		
	575-60	518	633	9/7	—	—	—	—	—	—	—	—	—	—	115	60		
	380-60	342	418	9/7	—	—	—	—	—	—	—	—	—	—	115	60		
300, 302	460-60	414	506	10/6	—	—	—	—	—	—	—	—	—	—	115	60		
	575-60	518	633	10/6	—	—	—	—	—	—	—	—	—	—	115	60		
	380-60	342	418	10/6	—	—	—	—	—	—	—	—	—	—	115	60		
325, 327	460-60	414	506	9/9	—	—	—	—	—	—	—	—	—	—	115	60		
	575-60	518	633	9/9	—	—	—	—	—	—	—	—	—	—	115	60		
	380-60	342	418	9/9	—	—	—	—	—	—	—	—	—	—	115	60		
350, 352	460-60	414	506	9/9	—	—	—	—	—	—	—	—	—	—	115	60		
	575-60	518	633	9/9	—	—	—	—	—	—	—	—	—	—	115	60		
	380-60	342	418	9/9	—	—	—	—	—	—	—	—	—	—	115	60		
401	460-60	414	506	11/9	—	—	—	—	—	—	—	—	—	—	115	60		
	575-60	518	633	11/9	—	—	—	—	—	—	—	—	—	—	115	60		
	380-60	342	418	11/9	—	—	—	—	—	—	—	—	—	—	115	60		
451	460-60	414	506	13/9	—	—	—	—	—	—	—	—	—	—	115	60		
	575-60	518	633	13/9	—	—	—	—	—	—	—	—	—	—	115	60		
	380-60	342	418	13/9	—	—	—	—	—	—	—	—	—	—	115	60		
476	460-60	414	506	11/11	—	—	—	—	—	—	—	—	—	—	115	60		
	575-60	518	633	11/11	—	—	—	—	—	—	—	—	—	—	115	60		
	380-60	342	418	11/11	—	—	—	—	—	—	—	—	—	—	115	60		
501	460-60	414	506	14/12	—	—	—	—	—	—	—	—	—	—	115	60		
	575-60	518	633	14/12	—	—	—	—	—	—	—	—	—	—	115	60		
	380-60	342	418	14/12	—	—	—	—	—	—	—	—	—	—	115	60		

LEGEND

- ICF — Instantaneous Current Flow
- MCA — Minimum Circuit Amps
- MOCP — Maximum Overcurrent Protection
- WD — Wye-Delta
- XL — Across-the-Line

NOTES:

- Units are suitable for use on electrical systems where voltage supplied to the unit terminals is not below or above the listed minimum and maximum limits. Maximum allowable phase imbalance is: voltage, 2%; amps 10%.
- Cooler heater (where applicable) is wired into the control circuit so it is always operable as long as the control power supply disconnect is on, even if any safety device is open.
- For MCA that is less than or equal to 380 amps, 3 conductors are required.
For MCA between 381-760 amps, 6 conductors are required.
For MCA between 761-1140 amps, 9 conductors are required.
For MCA between 1141-1520 amps, 12 conductors are required.
Calculation of conductors required is based on 75 C copper wire.

- Wiring for main field supply must be rated 75 C minimum. Use copper for all units.
 - Incoming wire size range for the terminal block is no. 4 AWG (American Wire Gage) to 500 kcmil.
 - Incoming wire size range of non-fused disconnect with MCA up to 599.9 amps is 3/0 to 500 kcmil.
 - Incoming wire size range of non-fused disconnect with MCA from 600 to 799.9 amps is 1/0 to 500 kcmil.
 - Incoming wire size range of non-fused disconnect with MCA from 800 to 1199.9 amps is 250 kcmil to 500 kcmil.
- Data provided as circuit 1/circuit 2 where there are two circuits.
- High ambient fan motors are not available on unit sizes 30XA080-122.



DUAL POINT (HIGH AMBIENT OPTION) (cont)

UNIT 30XA	UNIT VOLTAGE			NUMBER OF COND FANS	15 HP PUMP, 3450 RPM					CONTROL CIRCUIT	
	V-Hz (3 Ph)	Supplied			MCA	MOCP	ICF		Rec Fuse Size	Voltage 1 PH, 60 Hz	MCA and MOCP
		Min	Max				WD	XL			
140, 142	230-60	207	253	6/4	383.8/256.9	600/350	660.8/436.2	—	450/300	115	40
	200-60	187	220	6/4	422.6/283.1	700/400	756.7/497.5	—	500/350	115	40
	460-60	414	506	6/4	191.9/128.4	300/175	330.4/218.1	962.4/589.1	225/150	115	40
	575-60	518	633	6/4	147.7/ 99.4	225/150	263.9/174.3	769.9/471.3	175/125	115	40
	380-60	342	418	6/4	223.9/151.2	350/225	400.2/264.4	1165.2/713.4	300/175	115	40
160, 162	230-60	207	253	6/4	434.8/294.1	700/450	828.8/436.2	—	600/350	115	40
	200-60	187	220	6/4	478.1/323.7	800/500	950.7/497.5	—	600/400	115	40
	460-60	414	506	6/4	216.9/146.6	350/225	414.4/218.1	1222.4/589.1	300/175	115	40
	575-60	518	633	6/4	167.0/113.9	250/175	331.9/174.3	977.9/471.3	200/150	115	40
	380-60	342	418	6/4	253.3/172.7	400/250	501.2/264.4	1480.2/713.4	300/200	115	40
180, 182	230-60	207	253	6/6	—	—	—	—	—	115	60
	200-60	187	220	6/6	—	—	—	—	—	115	60
	460-60	414	506	6/6	—	—	—	—	—	115	60
	575-60	518	633	6/6	—	—	—	—	—	115	60
	380-60	342	418	6/6	—	—	—	—	—	115	60
200, 202	230-60	207	253	6/6	—	—	—	—	—	115	60
	200-60	187	220	6/6	—	—	—	—	—	115	60
	460-60	414	506	6/6	—	—	—	—	—	115	60
	575-60	518	633	6/6	—	—	—	—	—	115	60
	380-60	342	418	6/6	—	—	—	—	—	115	60
220, 222	230-60	207	253	7/6	—	—	—	—	—	115	60
	200-60	187	220	7/6	—	—	—	—	—	115	60
	460-60	414	506	7/6	—	—	—	—	—	115	60
	575-60	518	633	7/6	—	—	—	—	—	115	60
	380-60	342	418	7/6	—	—	—	—	—	115	60
240, 242	230-60	207	253	7/6	—	—	—	—	—	115	60
	200-60	187	220	7/6	—	—	—	—	—	115	60
	460-60	414	506	7/6	—	—	—	—	—	115	60
	575-60	518	633	7/6	—	—	—	—	—	115	60
	380-60	342	418	7/6	—	—	—	—	—	115	60
260, 262	460-60	414	506	9/6	—	—	—	—	—	115	60
	575-60	518	633	9/6	—	—	—	—	—	115	60
	380-60	342	418	9/6	—	—	—	—	—	115	60
280, 282	460-60	414	506	9/7	—	—	—	—	—	115	60
	575-60	518	633	9/7	—	—	—	—	—	115	60
	380-60	342	418	9/7	—	—	—	—	—	115	60
300, 302	460-60	414	506	10/6	—	—	—	—	—	115	60
	575-60	518	633	10/6	—	—	—	—	—	115	60
	380-60	342	418	10/6	—	—	—	—	—	115	60
325, 327	460-60	414	506	9/9	—	—	—	—	—	115	60
	575-60	518	633	9/9	—	—	—	—	—	115	60
	380-60	342	418	9/9	—	—	—	—	—	115	60
350, 352	460-60	414	506	9/9	—	—	—	—	—	115	60
	575-60	518	633	9/9	—	—	—	—	—	115	60
	380-60	342	418	9/9	—	—	—	—	—	115	60
401	460-60	414	506	11/9	—	—	—	—	—	115	60
	575-60	518	633	11/9	—	—	—	—	—	115	60
	380-60	342	418	11/9	—	—	—	—	—	115	60
451	460-60	414	506	13/9	—	—	—	—	—	115	60
	575-60	518	633	13/9	—	—	—	—	—	115	60
	380-60	342	418	13/9	—	—	—	—	—	115	60
476	460-60	414	506	11/11	—	—	—	—	—	115	60
	575-60	518	633	11/11	—	—	—	—	—	115	60
	380-60	342	418	11/11	—	—	—	—	—	115	60
501	460-60	414	506	14/12	—	—	—	—	—	115	60
	575-60	518	633	14/12	—	—	—	—	—	115	60
	380-60	342	418	14/12	—	—	—	—	—	115	60

LEGEND

- ICF — Instantaneous Current Flow
- MCA — Minimum Circuit Amps
- MOCP — Maximum Overcurrent Protection
- WD — Wye-Delta
- XL — Across-the-Line

NOTES:

1. Units are suitable for use on electrical systems where voltage supplied to the unit terminals is not below or above the listed minimum and maximum limits. Maximum allowable phase imbalance is: voltage, 2%; amps 10%.
2. Cooler heater (where applicable) is wired into the control circuit so it is always operable as long as the control power supply disconnect is on, even if any safety device is open.
3. For MCA that is less than or equal to 380 amps, 3 conductors are required.
For MCA between 381-760 amps, 6 conductors are required.
For MCA between 761-1140 amps, 9 conductors are required.
For MCA between 1141-1520 amps, 12 conductors are required.
Calculation of conductors required is based on 75 C copper wire.

4. Wiring for main field supply must be rated 75 C minimum. Use copper for all units.
 - a. Incoming wire size range for the terminal block is no. 4 AWG (American Wire Gage) to 500 kcmil.
 - b. Incoming wire size range of non-fused disconnect with MCA up to 599.9 amps is 3/0 to 500 kcmil.
 - c. Incoming wire size range of non-fused disconnect with MCA from 600 to 799.9 amps is 1/0 to 500 kcmil.
 - d. Incoming wire size range of non-fused disconnect with MCA from 800 to 1199.9 amps is 250 kcmil to 500 kcmil.
5. Data provided as circuit 1/circuit 2 where there are two circuits.
6. High ambient fan motors are not available on unit sizes 30XA080-122.



COMPRESSOR AND FAN ELECTRICAL DATA

30XA UNIT SIZE	UNIT VOLTAGE V-Hz (3 Ph, 60 Hz)	NUMBER OF COND FANS*	CONDENSER FANS FLA		COMPRESSOR							
					A				B			
			High Ambient Temp Cond. Fans (1140 rpm)	Standard Cond. Fans (850 rpm)	LRA (All Units)		RLA		LRA (All Units)		RLA	
		XL	WD	High Ambient Temp Cond. Fans (1140 rpm)	Standard Cond. Fans (850 rpm)	XL	WD	High Ambient Temp Cond. Fans (1140 rpm)	Standard Cond. Fans (850 rpm)	XL	WD	
080, 082	200	3/3	—	6.6	1162	373	—	136.8	1162	373	—	136.8
	230	3/3	—	6.0	1010	324	—	124.2	1010	324	—	124.2
	380	3/3	—	3.6	611	196	—	71.9	611	196	—	71.9
	460	3/3	—	3.0	505	162	—	62.1	505	162	—	62.1
	575	3/3	—	2.4	404	130	—	47.5	404	130	—	47.5
090, 092	200	4/4	—	6.6	1162	373	—	140.0	1162	373	—	140.0
	230	4/4	—	6.0	1010	324	—	127.1	1010	324	—	127.1
	380	4/4	—	3.6	611	196	—	73.5	611	196	—	73.5
	460	4/4	—	3.0	505	162	—	63.6	505	162	—	63.6
	575	4/4	—	2.4	404	130	—	48.6	404	130	—	48.6
100, 102	200	4/4	—	6.6	1254	400	—	154.8	1254	400	—	154.8
	230	4/4	—	6.0	1090	348	—	140.7	1090	348	—	140.7
	380	4/4	—	3.6	660	211	—	81.6	660	211	—	81.6
	460	4/4	—	3.0	545	174	—	70.4	545	174	—	70.4
	575	4/4	—	2.4	436	139	—	53.5	436	139	—	53.5
110, 112	200	4/4	—	6.6	1254	400	—	190.7	1254	400	—	154.8
	230	4/4	—	6.0	1090	348	—	173.6	1090	348	—	140.7
	380	4/4	—	3.6	660	211	—	100.6	660	211	—	81.6
	460	4/4	—	3.0	545	174	—	86.4	545	174	—	70.4
	575	4/4	—	2.4	436	139	—	66.3	436	139	—	53.5
120, 122	200	4/4	—	6.6	1254	400	—	190.7	1254	400	—	190.7
	230	4/4	—	6.0	1090	348	—	173.6	1090	348	—	173.6
	380	4/4	—	3.6	660	211	—	100.6	660	211	—	100.6
	460	4/4	—	3.0	545	174	—	86.4	545	174	—	86.4
	575	4/4	—	2.4	436	139	—	66.3	436	139	—	66.3
140, 142	200	6/4	11.9	6.6	2139	685	280.8	293.9	1254	400	148.4	154.8
	230	6/4	10.8	6.0	1860	596	255.2	267.2	1090	348	134.9	140.7
	380	6/4	6.5	3.6	1126	361	147.7	154.6	660	211	78.3	81.6
	460	6/4	5.4	3.0	930	298	127.6	133.6	545	174	67.5	70.4
	575	6/4	4.3	2.4	744	238	97.5	102.0	436	139	51.3	53.5
160, 162	200	6/4	11.9	6.6	2737	879	325.2	340.6	1254	400	180.9	190.7
	230	6/4	10.8	6.0	2380	764	296.0	310.0	1090	348	164.7	173.6
	380	6/4	6.5	3.6	1441	462	171.3	179.4	660	211	95.4	100.6
	460	6/4	5.4	3.0	1190	382	147.6	154.6	545	174	82.0	86.4
	575	6/4	4.3	2.4	952	306	112.9	118.2	436	139	62.9	66.3
180, 182	200	6/6	11.9	6.6	2139	685	280.8	293.9	2139	685	280.8	293.9
	230	6/6	10.8	6.0	1860	596	255.2	267.2	1860	596	255.2	267.2
	380	6/6	6.5	3.6	1126	361	147.7	154.6	1126	361	147.7	154.6
	460	6/6	5.4	3.0	930	298	127.6	133.6	930	298	127.6	133.6
	575	6/6	4.3	2.4	744	238	97.5	102.0	744	238	97.5	102.0
200, 202	200	6/6	11.9	6.6	2737	879	325.2	340.6	2737	879	325.2	340.6
	230	6/6	10.8	6.0	2380	764	296.0	310.0	2380	764	296.0	310.0
	380	6/6	6.5	3.6	1441	462	171.3	179.4	1441	462	171.3	179.4
	460	6/6	5.4	3.0	1190	382	147.6	154.6	1190	382	147.6	154.6
	575	6/6	4.3	2.4	952	306	112.9	118.2	952	306	112.9	118.2
220, 222	200	7/6	11.9	6.6	2737	879	387.3	406.6	2737	879	325.2	340.6
	230	7/6	10.8	6.0	2380	764	352.3	369.8	2380	764	296.0	310.0
	380	7/6	6.5	3.6	1441	462	204.2	214.3	1441	462	171.3	179.4
	460	7/6	5.4	3.0	1190	382	176.1	184.9	1190	382	147.6	154.6
	575	7/6	4.3	2.4	952	306	134.8	141.5	952	306	112.9	118.2
240, 242	200	7/6	11.9	6.6	2737	879	387.3	406.6	2737	879	387.3	406.6
	230	7/6	10.8	6.0	2380	764	352.3	369.8	2380	764	352.3	369.8
	380	7/6	6.5	3.6	1441	462	204.2	214.3	1441	462	204.2	214.3
	460	7/6	5.4	3.0	1190	382	176.1	184.9	1190	382	176.1	184.9
	575	7/6	4.3	2.4	952	306	134.8	141.5	952	306	134.8	141.5

LEGEND

FLA — Full Load Amps WD — Wye Delta
 LRA — Locked Rotor Amps XL — Across-the-Line
 RLA — Rated Load Amps

NOTES:

- For 30XA080-501 units with dual power supply, main power supply 1 uses refrigerant circuit A components to calculate MCA and MOCP. Main power supply 2 uses refrigerant circuit B components to calculate MCA and MOCP.
- For 30XA080-501 units with dual power supply, main power supply 1 uses refrigerant circuit A components to calculate MCA and MOCP. Main power supply 2 uses refrigerant circuit B components to calculate MCA and MOCP.

*Quantity of fan motors for incoming power supply Circuit 1/Circuit 2.

COMPRESSOR AND FAN ELECTRICAL DATA (cont)

30XA UNIT SIZE	UNIT VOLTAGE V-Hz (3 Ph, 60 Hz)	NUMBER OF COND FANS*	CONDENSER FANS FLA		COMPRESSOR							
					A				B			
					LRA (All Units)		RLA		LRA (All Units)		RLA	
High Ambient Temp Cond. Fans (1140 rpm)	Standard Cond. Fans (850 rpm)	XL	WD	High Ambient Temp Cond. Fans (1140 rpm)	Standard Cond. Fans (850 rpm)	XL	WD	High Ambient Temp Cond. Fans (1140 rpm)	Standard Cond. Fans (850 rpm)			
260, 262	380	9/6	6.5	3.6	2179	700	277.9	293.0	1441	462	171.3	179.4
	460	9/6	5.4	3.0	1800	578	240.4	253.5	1190	382	147.6	154.6
	575	9/6	4.3	2.4	1440	462	183.7	193.7	952	306	112.9	118.2
280, 282	380	9/7	6.5	3.6	2179	700	277.9	293.0	1441	462	204.2	214.3
	460	9/7	5.4	3.0	1800	578	240.4	253.5	1190	382	176.1	184.9
	575	9/7	4.3	2.4	1440	462	183.7	193.7	952	306	134.8	141.5
300, 302	380	10/6	6.5	3.6	2179	700	330.8	350.3	1441	462	204.2	214.3
	460	10/6	5.4	3.0	1800	578	285.6	302.4	1190	382	176.1	184.9
	575	10/6	4.3	2.4	1440	462	218.2	231.0	952	306	134.8	141.5
325, 327	380	9/9	6.5	3.6	2179	700	277.9	293.0	2179	700	277.9	293.0
	460	9/9	5.4	3.0	1800	578	240.4	253.5	1800	578	240.4	253.5
	575	9/9	4.3	2.4	1440	462	183.7	193.7	1440	462	183.7	193.7
350, 352	380	9/9	6.5	3.6	2179	700	330.8	350.3	2179	700	277.9	293.0
	460	9/9	5.4	3.0	1800	578	285.6	302.4	1800	578	240.4	253.5
	575	9/9	4.3	2.4	1440	462	218.2	231.0	1440	462	183.7	193.7
401	380	11/9	6.5	—	2312	758	449.8	—	2179	700	418.9	—
	460	11/9	5.4	—	1906	625	371.0	—	1800	578	346.3	—
	575	11/9	4.3	—	1521	498	294.8	—	1440	462	275.0	—
451	380	13/9	6.5	—	2312	758	529.4	—	2179	700	403.9	—
	460	13/9	5.4	—	1906	625	438.2	—	1800	578	346.3	—
	575	13/9	4.3	—	1521	498	349.5	—	1440	462	266.4	—
476	380	11/11	6.5	—	2312	756	490.8	—	2312	758	449.8	—
	460	11/11	5.4	—	1906	625	404.3	—	1906	625	371.0	—
	575	11/11	4.3	—	1521	498	323.0	—	1521	498	294.8	—
501	380	14/12	6.5	—	2312	758	535.9	—	2312	758	497.3	—
	460	14/12	5.4	—	1906	625	443.6	—	1906	625	409.7	—
	575	14/12	4.3	—	1521	498	353.8	—	1521	498	327.3	—

LEGEND

FLA — Full Load Amps **WD** — Wye Delta
LRA — Locked Rotor Amps **XL** — Across-the-Line
RLA — Rated Load Amps

*Quantity of fan motors for incoming power supply Circuit 1/Circuit 2.

NOTES:

- For 30XA080-501 units with dual power supply, main power supply 1 uses refrigerant circuit A components to calculate MCA and MOCP. Main power supply 2 uses refrigerant circuit B components to calculate MCA and MOCP.
- For 30XA080-501 units with dual power supply, main power supply 1 uses refrigerant circuit A components to calculate MCA and MOCP. Main power supply 2 uses refrigerant circuit B components to calculate MCA and MOCP.

PUMP ELECTRICAL DATA

PUMP HP	UNIT VOLTAGE V-Hz (3 Ph)	HYDRONIC SYSTEM (SINGLE OR DUAL) FLA (Each)	30XA UNIT SIZE
5	230-60	11.6	090-162
	200-60	12.6	
	460-60	5.8	
	575-60	4.6	
	380-60	7.0	
7.5	230-60	17.4	090-162
	200-60	18.5	
	460-60	8.7	
	575-60	7.0	
	380-60	10.4	
10	230-60	23.0	090-162
	200-60	25.0	
	460-60	11.5	
	575-60	9.2	
	380-60	14.0	
15	230-60	34.0	090-162
	200-60	36.7	
	460-60	17.0	
	575-60	14.0	
	380-60	21.0	

FLA — Full Load Amps

Microprocessor

The *ComfortLink* microprocessor controls overall unit operation and controls a number of processes simultaneously. These processes include internal timers, reading inputs, analog to digital conversions, fan control, display control, diagnostic control, output relay control, demand limit, capacity control, head pressure control, and temperature reset. Some processes are updated almost continuously, others every 2 to 3 seconds, and some every 30 seconds. The microprocessor routine is started by switching the Emergency ON-OFF switch to ON position. Pump control of external, single pumps (where configured) will energize the cooler pump to the internal (or CCN) time schedule (or input occupied signal from external system). If chiller control of dual, external pumps is required, the external pump control accessory package (part number 00EFN900003200A) must be installed.

When the unit receives a call for cooling (based on a deviation from chilled water set point), the unit stages up in capacity to maintain the cooler fluid set point. The first compressor starts 1 to 3 minutes after the call for cooling. The *ComfortLink* microprocessor controls the capacity of the chiller by varying the number of compressors on and each loading capacity to satisfy actual dynamic load conditions. The control maintains leaving-fluid temperature set point shown on the Navigator™ device through intelligent positioning of the slide valve and compressor cycling. Accuracy depends on loop volume, loop flow rate, load, and outdoor-air temperature. No adjustment for cooling range or cooler flow rate is required, because the control automatically compensates for cooling range by measuring both return-fluid temperature and leaving-fluid temperature. This is referred to as leaving-fluid temperature control with return-fluid temperature compensation.

The basic logic for determining when to add or remove capacity is a time band integration of deviation from set point plus rate of change of leaving-fluid temperature. When leaving-fluid temperature is close to the set point and slowly moving closer, logic prevents additional capacity. If leaving-fluid temperature is less than 34°F (1.1°C) for water, or 6°F (3.3°C) below the brine freeze set point for brine units, the unit is shut off until the water temperature for brine reaches 34°F (1.1°C) or to 6°F (3.3°C) above the set point for brine to protect against freezing.

If pulldown control has been selected (adjustable setting), no additional capacity is added as long as the difference between leaving-fluid temperature and the set point is greater than 4°F (2.2°C) and rate of change in leaving-water temperature is greater than the adjustable setting. If it has been less than 90 seconds since the last capacity change, compressors will continue to run unless a safety device trips. This prevents rapid cycling and also helps return oil during short operating periods.

Control sequence

Off cycle — If ambient temperature is below 36°F (2.2°C), cooler heaters (if installed) are also energized.

Start-up — After control circuit switches on, the prestart process takes place, then microprocessor checks itself, starts pump (if configured) and waits for temperature to stabilize.

The controlled pulldown feature limits compressor loading on start-up to reduce demand on start-up and unnecessary compressor usage.

Capacity control — On the first call for cooling, the microprocessor starts initial compressor and fan stage on lead circuit.

As additional cooling is required, the capacity of the compressor is increased by changing the position of the slide valve. As the load increases above the compressor's capacity, another compressor is started and both are staged together.

The speed at which capacity is added or reduced is controlled by temperature deviation from set point and rate of temperature change of chilled fluid.

The main base board (MBB) responds to the supply chilled water temperature to cycle the compressors to match cooling load requirements.

The minimum load control valve is energized by the MBB. The valve allows hot gas to pass directly into the cooler circuit on the initial step of unloading, permitting the unit to operate at lower loads with less compressor cycling.

Sensors

Thermistors are used to control temperature-sensing inputs to the microprocessor. No additional thermistor sensors are required for optional leaving chilled water temperature, return water, or outdoor air reset.

The following temperature sensors are provided on 30XA units:

- Cooler leaving chilled fluid temperature (T1)
- Cooler entering fluid (return) temperature (T2)
- Outside-air temperature (T9)
- Space temperature (T10)

Two refrigerant pressure transducers are used in each circuit for sensing suction and discharge pressure. The microprocessor uses these inputs to control capacity and fan cycling.

The following pressure transducers are provided on 30XA units:

- Saturated condensing temperature
- Cooler saturation temperature
- Oil
- Economizer (sizes 090-501)

Additional information

Detailed information on controls and operation is available in the Controls, Start-Up, Operation, Service, and Troubleshooting guide included with each unit. Packaged Service Training programs are also available. Contact your local Carrier representative for more information.

ComfortLink controls

Dynamic *ComfortLink* controls keep the chiller on line during periods of extreme operating conditions. If the entering fluid temperature is 95°F (35°C) and the saturated suction temperature is 50°F (10°C) or higher the maximum operating pressure (MOP) feature limits the suction to keep the chiller online. The controller automatically starts the chiller in the

unloaded state to eliminate the potential of compressor overload due to high head pressure or low suction pressure. The controller will equalize run time on each circuit through the lead/lag feature. If a circuit becomes disabled, the controller will automatically set the active circuit to lead, keeping the chiller online at a reduced capacity.

Standard ComfortLink controls with Touch Pilot™ display — A touch screen display for convenient access to unit status, operation, configuration and troubleshooting diagnostics capability is standard on 30XA units. The VGA LCD display provides clear language information in English, French, Spanish, or Portuguese. The weather-proof enclosure makes the display ideally suited for outdoor applications.

Low-temperature override — This feature prevents LCWT (leaving chilled water temperature) from overshooting the set point and possibly causing a nuisance trip-out by the freeze protection.

High-temperature override — This feature allows the chiller to add capacity quickly during rapid load variations.

Temperature reset

The energy management module is required for 4 to 20 mA reset of LCWT in constant fluid systems. Reset by return fluid, outdoor-air temperature, or space temperature does not require this option. Reset reduces compressor power usage at part load when design LCWT is not necessary. Humidity control should be considered since higher coil temperatures resulting from reset will reduce latent heat capacity. Three reset options are offered, based on the following:

Return-fluid temperature — Increases LCWT set point as return (or entering) fluid temperature decreases (indicating load decrease). Option may be used in any application where return fluid provides accurate load indication. A limitation of return fluid reset is that LCWT may only be reset to value of design return fluid temperature.

Outdoor-air temperature — Increases the LCWT as outdoor ambient temperature decreases (indicating load decrease). This reset should be applied only where outdoor ambient temperature is an accurate indication of load.

Space temperature — Increases the LCWT as space temperature decreases (indicating load decrease). This reset should be applied only where space temperature is an accurate indication of load. An accessory space temperature thermistor is required.

For details on applying a reset option, refer to the Controls, Start-Up, Operation, Service and Troubleshooting literature shipped with the unit. Obtain ordering part numbers for reset option from the Packaged Chiller Builder program or contact your local Carrier representative.

Safety

Abnormal conditions — All control safeties in the chiller operate through compressor protection board or control relay and microprocessor.

Loss of feedback signal to the MBB will cause the compressor(s) to shut down. For other safeties, microprocessor makes appropriate decision to shut down a compressor due to a safety trip or bad sensor reading and displays

appropriate failure code on the display. Chiller holds in safety mode until reset; it then reverts to normal control when unit is reset.

Low-pressure safety — Safety cuts out if system pressure drops below minimum.

High-pressure cutout — Switch shuts down compressors if compressor discharge pressure increases to 290.3 psig (2001.5 kPa).

Compressor anti-cycling — This feature limits compressor cycling.

Loss of flow protection — Proof of flow switches are standard and installed on all 30XA chillers.

Sensor failures — Failures are detected by the microprocessor.

Accessory controls

Demand can be limited by controlling the chiller capacity through the demand limit control (the energy management module is required for this function). This FIOP/accessory interfaces with the microprocessor to control the unit so that the chiller's kW demand does not exceed its setting. It is activated from an external switch or a 4 to 20 mA signal.

The standard *ComfortLink* controller is programmed to accept various accessory temperature reset options (based on outdoor-air temperature [standard], return-fluid temperature [standard], or space temperature [which requires accessory thermistor]), that reset the LCWT. An accessory thermistor (T10) is required if space temperature reset is selected. The Energy Management Module (EMM) is only required for temperature reset that is initiated by a 4 to 20 mA signal.

Demand limit

If the demand limit is applied, it limits the total power draw of unit to a selected point by controlling the number of operational compressors during periods of peak electrical demand.

The energy management module is required for either 2-step or 4 to 20 mA demand limit.

Electronic expansion valve (EXV)

The EXV controls refrigerant flow to the cooler for different operating conditions by varying an orifice size to increase or decrease the flow area through the valve based on microprocessor input. The orifice is positioned by a stepper motor through approximately 3,600 discrete steps and is monitored every three seconds.

Diagnostics

The microprocessor may be put through a service test (see Controls, Start-Up, Operation, Service, and Troubleshooting literature). Service test confirms microprocessor is functional, informs observer through display the condition of each sensor and switch in chiller, and allows observer to check for proper operation of fans and compressors.

Default settings

To facilitate quick start-ups, 30XA chillers with *ComfortLink* controls are pre-configured with a default setting that assumes stand-alone operation supplying 44°F (6.6°C) chilled water.

Controls (cont)



Configuration settings will be based on any options or accessories included with the unit at the time of manufacturing.

Date and time are set to U.S.A. Eastern Time zone and will need reconfiguring based on location and local time zone. If operation based on occupancy scheduling is desired, schedule must be set during installation.

Ice duty

ComfortLink controls have the capability of reduced leaving fluid temperature operation for thermal storage, or ice duty. The optional Energy Management display includes input contacts for the “ice done” signal generated by the thermal storage control system. The ice duty feature may be configured to start on an external input command or by the *ComfortLink* standard internal scheduling function. The ice duty

function requires brine modification for leaving fluid temperatures below 40°F (4.4°C). Ice duty may be used in combination with any other standard features offered by the energy management module and *ComfortLink* controls.

The production of ice, which is stored for peak cooling demands, can significantly decrease energy costs. The unit produces ice (normally at night) by supplying ice storage tanks with low temperature cooling fluid. The chiller takes advantage of reduced ambient conditions at night for ice-making mode, so the capacity suffers a lower penalty for the low leaving fluid temperatures.

At peak cooling demands, the chiller and the stored ice may share the cooling load to reduce operating costs. The thermal storage system may potentially reduce the size of the chiller plant required to meet demand loads.

Control and power wiring schematic

LEGEND

—	Alarm
—	American Wire Gage
—	Energy Management
—	High Short Circuit Current Rating
—	Minimum Circuit Amps
—	Minimum Load Valve
—	National Electric Code
—	Chilled Water Pump
—	Chilled Water Pump Interlock
—	Chilled Water Pump VFD
—	Short Circuit Current Rating
—	Terminal Block
—	Variable Frequency Device

A	AWG
EMM	HSCCR
MCA	MLV
NEC	PMP
PMP1	PVPD
SCCR	TB
VFD	

- NOTES:**
- Factory wiring is in accordance with UL 1995 standards. Field modifications or additions must be in compliance with all applicable codes.
 - Wiring for main field supply must be rated 75 C minimum. Use copper for all units.
 - Incoming wire size range for the terminal block is no. 4 AWG to 500 kcmil.
 - Incoming wire size range of non-fused disconnect with MCA up to 599.9 amps is 3/0 to 500 kcmil.
 - Incoming wire size range of non-fused disconnect with MCA from 600 to 799.99 amps is 1/0 to 500 kcmil.
 - Incoming wire size range of non-fused disconnect with MCA from 800 to 1199.99 amps is 250 to 500 kcmil.
 - Terminals 9 and 10 of TB5 are for field external connections for remote on-off. The contacts must be rated for dry circuit application capable of handling a 24-vac load up to 50 mA.
 - Terminals 1 and 2 of TB5 are for external connections of chilled water pump interlock. The contacts must be rated for dry circuit application capable of handling a 24-vac load up to 50 mA.
 - Terminals 11 and 13 of TB5 are for control of chilled water pump 1 (PMP-1) starter. Terminals 13 and 15 of TB5 are for control of chilled water pump 2 (PMP-2) starter. The maximum load allowed for the chilled water pump relay is 5 VA sealed, 10 VA inrush at 24 v. Field power supply is not required.
 - For control of chilled water pumps, a set of normally open contacts rated for dry circuit application must be supplied from field-supplied pump starter relay. Connect contacts to violet and pink wires in harness from main base board Channel 18. Wires in harness are marked PMP1-13 and PMP1-14.
 - Terminals 12 and 13 of TB5 are for an alarm relay. The maximum load allowed for the alarm relay is 10 VA sealed, 25 VA inrush at 24 v. Field power supply is not required.
 - Make appropriate connections to TB6 as shown for Energy Management board options, the contacts for Occupancy Override, Demand Limit, and Ice Done options must be rated for dry circuit application capable of handling a 24 vac load up to 50 mA.
 - Terminal blocks TB5 and TB6 are located in the display panel box for all units. Refer to the certified dimensional drawing for each unit to get the exact locations.
 - Refer to certified dimensional drawings for exact locations of the main power and control power entrance locations.
 - J3-24 and 25 of EMM board are for run relay and shutdown relay. The maximum load allowed for the run and shutdown relay is 10 VA sealed, 25 VA inrush at 24 v.

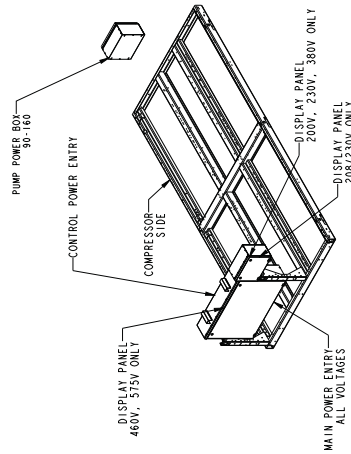
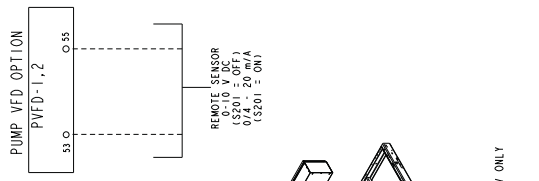
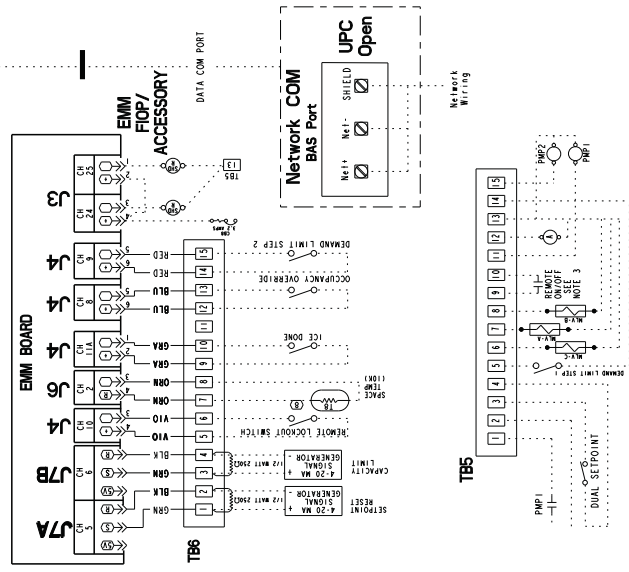
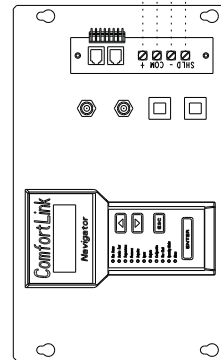
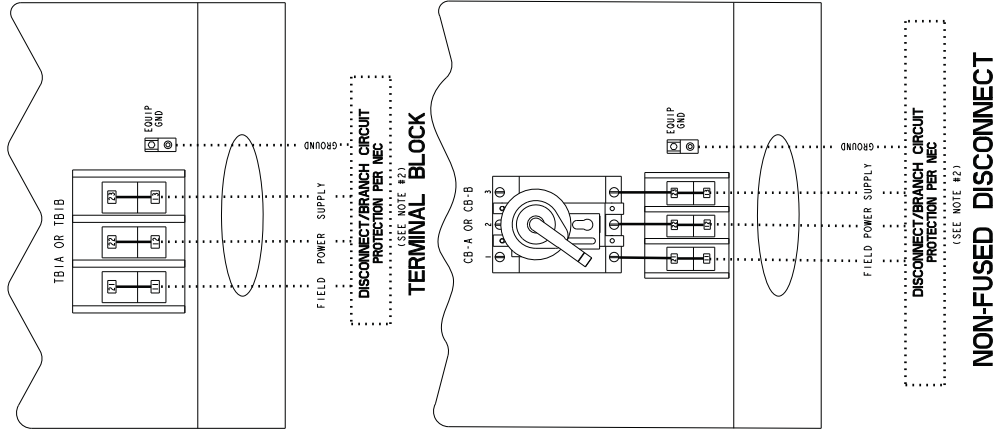

080-122 UNIT SIZE

NON-FUSED DISCONNECT

Control and power wiring schematic (cont)

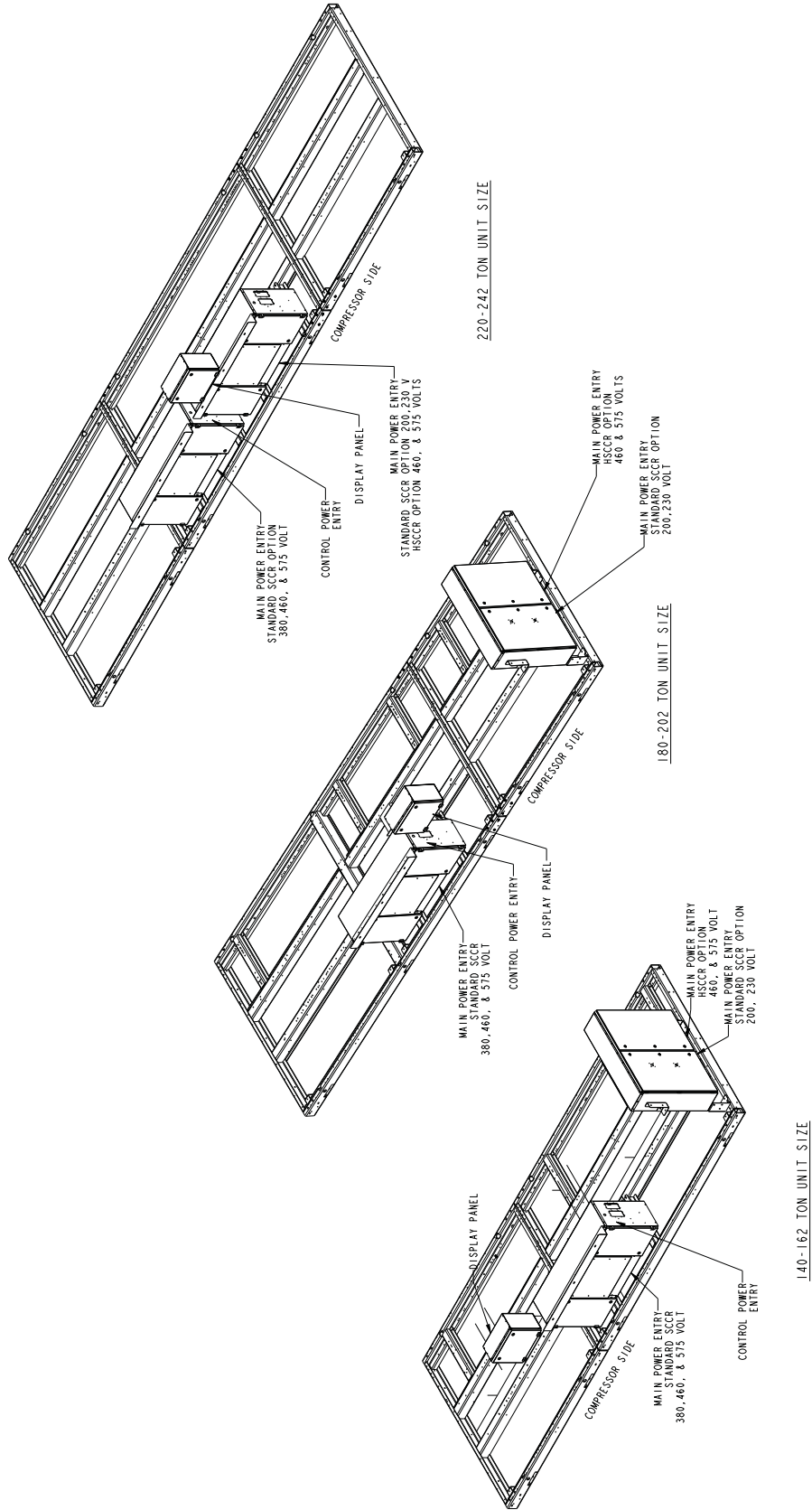

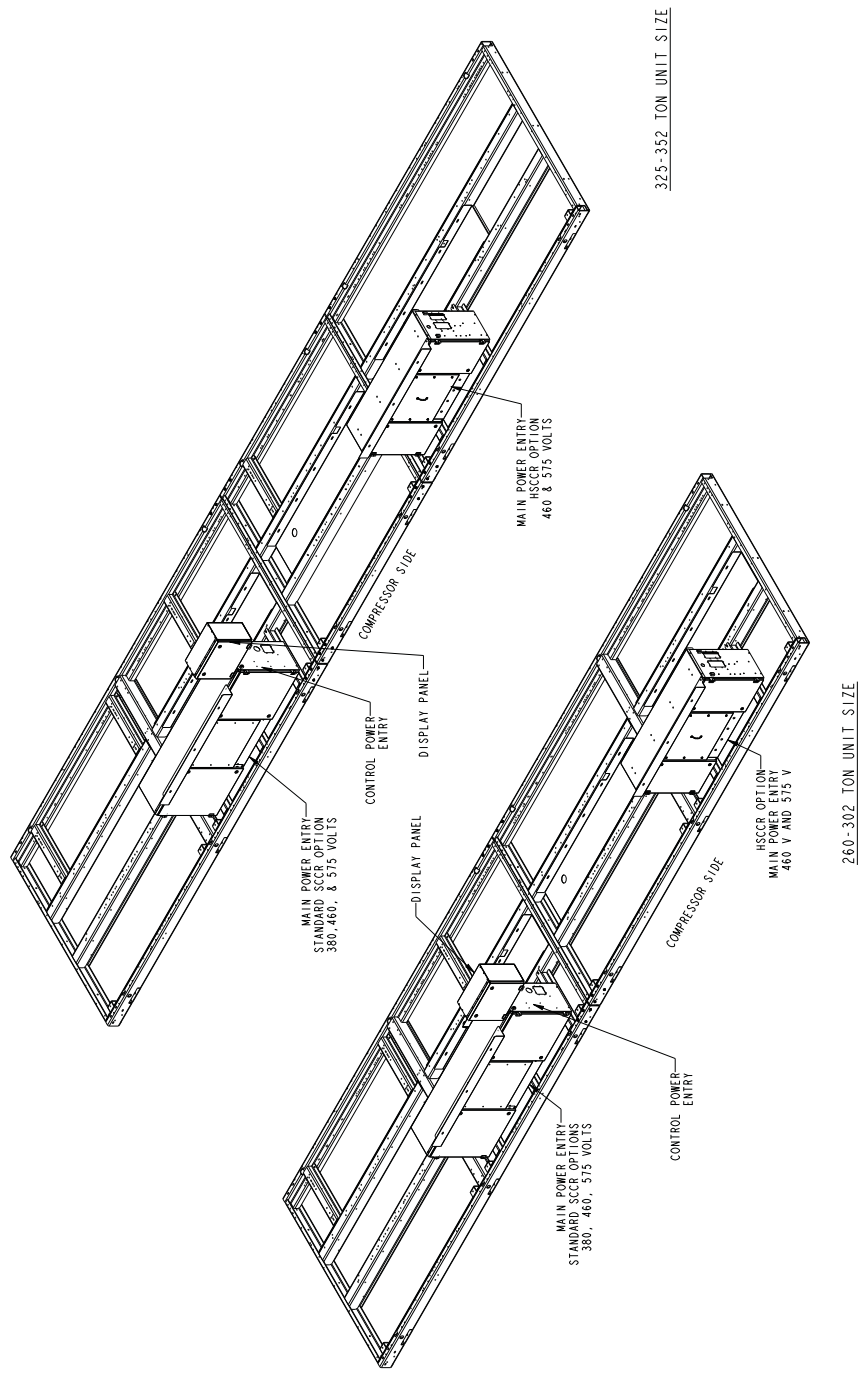

Control and power wiring schematic (cont)

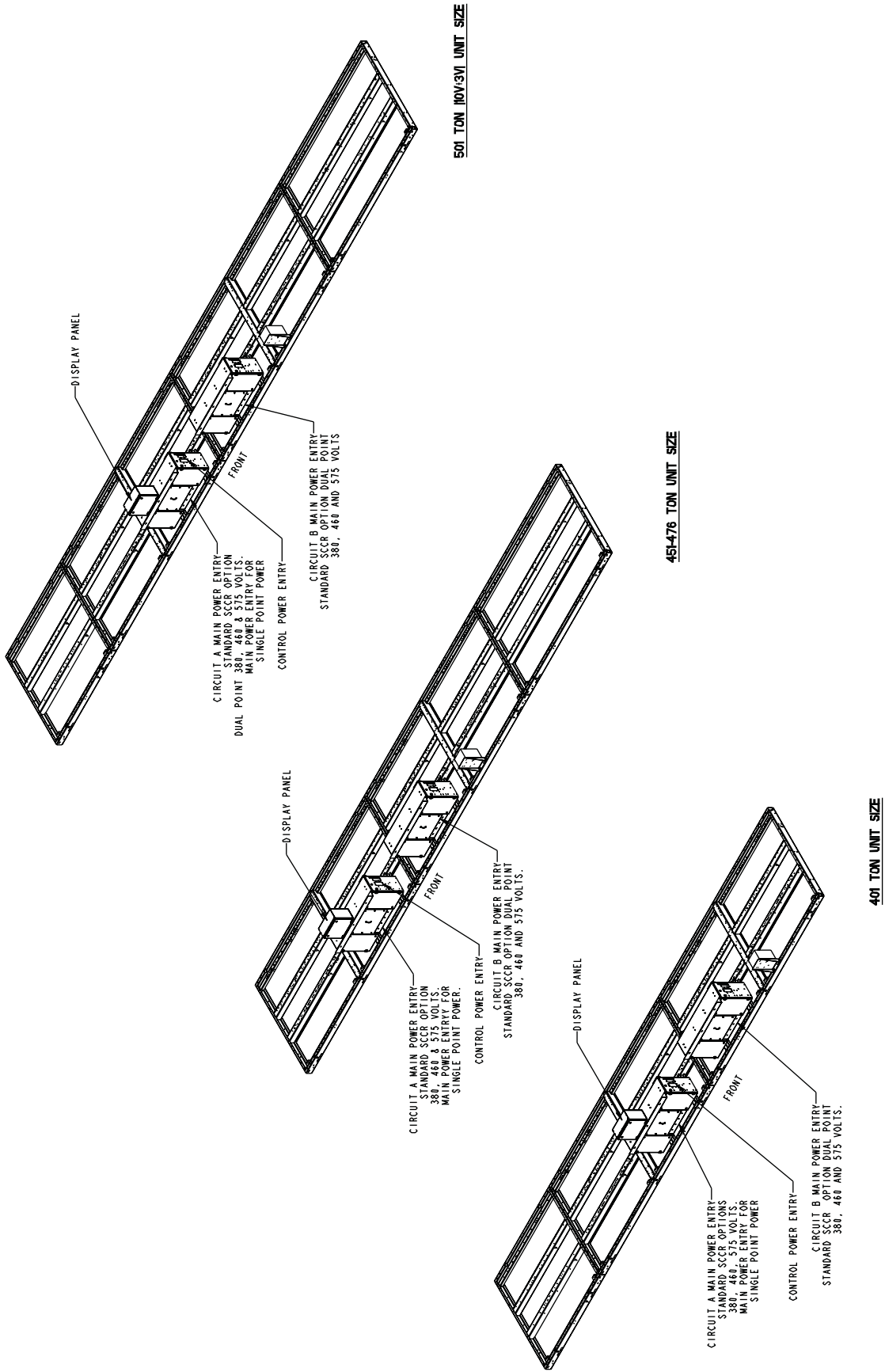

Chiller location and clearances

The 30XA unit must be installed outdoors.

Do not locate near sound sensitive areas without proper acoustic consideration. For applications requiring mounting a chiller on a building rooftop, consideration should be given to using rubber-in-shear or spring isolators to minimize structure-borne transmission. Unit must be level when installed to ensure proper oil return to the compressors. Clearances must be provided around chillers for airflow, service and local code requirements. See dimensional drawings for specific unit clearance requirements. Ensure adequate clearance between adjacent chillers is maintained. A minimum of 10 ft (3.0 m) is recommended. Chiller fan discharge must be at least as high as adjacent solid walls. Installation in pits is not recommended.

Minimum clearances

The recommended minimum clearance to ensure proper airflow through the condenser coils and to allow fan maintenance is as shown below.

Acceptable clearance on the cooler connection side or end opposite the control box of the unit can be reduced to 3 ft (1 m) without sacrificing performance as long as the remaining three sides are unrestricted. Acceptable clearance on the side with a control box can be reduced to 4 ft (1.3 m) due to NEC (National Electric Code, U.S.A.) regulations, without sacrificing performance as long as the remaining three sides are unrestricted. Clearance between chillers in dual chiller applications may be reduced to 6 ft (1.8 m) without sacrificing performance provided the remaining sides are unrestricted. For acceptable clearance with layout involving more than 2 chillers, please contact application engineering.

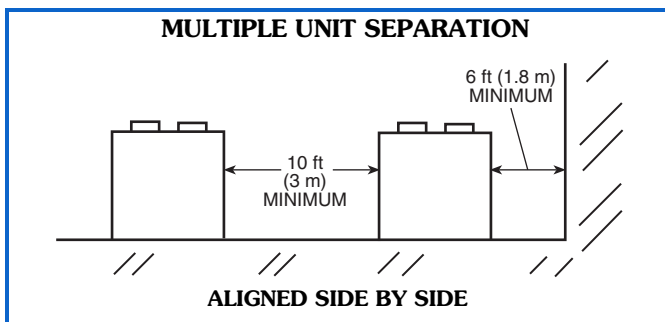

Strainers

A screen strainer with a minimum screen size of 20 mesh must be installed a maximum of 10 ft (3 m) from the unit to prevent debris from damaging internal tubes of the cooler.

STRAINER REQUIREMENTS

APPLICATION	30XA (ANY HEAT EXCHANGER TYPE)	
	With Hydronic Package*	Without Hydronic Package
	Type of Strainer	
Closed Loop	1/8-in. Perforated (Factory Supplied)	20 Mesh†
Open Loop	1/8-in. Perforated (Factory Supplied) and 20 Mesh†	20 Mesh†

* Units with a hydronic package are shipped with a fine mesh start-up strainer that must be removed within 24 hours after start-up.

† A 20-mesh strainer must be field supplied and installed within 10 ft (3 m) of the cooler inlet.

Oversizing chillers

Oversizing chillers by more than 15% at design conditions must be avoided as the system operating efficiency is adversely affected (resulting in greater or excessive electrical demand). When future expansion of equipment is anticipated, install a single chiller to meet present load requirements and add a second chiller to meet the additional load demand. It is also recommended that 2 smaller chillers be installed where operation at minimum load is critical. The operation of a smaller chiller loaded to a greater percentage over minimum is preferred to operating a single chiller at or near its minimum recommended value. Minimum load control should not be used as a means to allow oversizing chillers. Minimum load control should be given consideration where substantial operating time is anticipated below the minimum unloading step.

Cooler water temperature

1. Maximum leaving chilled water temperature (LCWT) for the unit is 60°F (15.5°C). Unit can start and pull down with up to 95°F (35°C) entering-water temperature. The entering-water temperature must not exceed 70°F (21.1°C).
2. Minimum LCWT is 40°F (4.4°C). For leaving-water temperatures below 39.9°F (4.4°C) an inhibited anti-freeze solution is required. Application of chiller at leaving fluid temperatures lower than 30°F (-1.1°C) is not available on 30XA401-501 units, but it is possible on all other unit sizes by including suction line insulation and low ambient head pressure control, and when a flooded cooler is employed, a plus-one-pass cooler is also required. The low leaving fluid temperature applications are generally best accomplished by employing the DX cooler option.

The flooded cooler may be used on applications with leaving fluid temperatures lower than 30°F (-1.1°C) by strictly adhering to the limits presented in the table below.

FLOODED COOLER LOW LCWT RESTRICTIONS

PARAMETER	30XA SIZES	BRINE TYPE	
		EG	PG
Cooler Passes	080-350	3 (or +1)	3 (or +1)
Minimum Leaving Fluid Temperature	080-350	21.2°F (-6.0°C)	26.6°F (-2.9°C)
Maximum Glycol	080-350	35%	33%
Allowable Cooler Delta Temperature*	080-090	2.0 to 7.2 delta °F (1.1 to 4.0 delta °C)	2.0 to 5.4 delta °F (1.1 to 3.0 delta °C)
	100-350	2.0 to 7.2 delta °F (1.1 to 4.0 delta °C)	2.0 to 7.2 delta °F (1.1 to 4.0 delta °C)

LEGEND

EG — Ethylene Glycol
 LCWT — Leaving Chiller Water Temperature
 PG — Propylene Glycol

* Leaving fluid temperature less than 32°F (0°C).

NOTES:

1. Water flowing through cooler should not exceed 100°F (37.8°C).
2. Direct expansion (DX) cooler can operate down to 15°F (-1.1°C) without these restrictions.

Cooler flow/range

Ratings and performance data in this publication are for a cooling temperature rise of 10°F (5.6°C). The 30XA chillers may be operated at a different temperature rise, providing flow limits are not exceeded and corrections to

system guidelines are made. For minimum and maximum cooler flow rates, see the Minimum and Maximum Cooler Flow Rates table. A high flow rate is generally limited by the maximum pressure drop that can be tolerated by the unit. The 30XA chillers are designed for a full load temperature rise of 3° to 20°F (1.7° to 11.1°C). Use the Carrier Selection Program to obtain the rating if a temperature rise other than 10°F (5.6°C) is used. The DX cooler option is the preferred choice for applications with leaving fluid temperatures lower than 30°F (-1.1°C).

Minimum cooler flow (maximum cooler temperature rise) — The minimum cooler flow for all units is shown in the Minimum and Maximum Cooler Flow Rates table on page 122. When system design conditions require a lower flow (or higher rise) than the minimum allowable cooler flow, follow the recommendations below.

- Multiple smaller chillers may be applied in series, each providing a portion of the design temperature rise.
- Cooler fluid may be recirculated to raise the flow rate to the chiller. The mixed temperature entering the cooler must be maintained to a minimum of at least 3°F (1.7°C) above the LCWT and a maximum of no more than 20°F (11.1°C) above the LCWT.

NOTE: Recirculation flow is shown below.

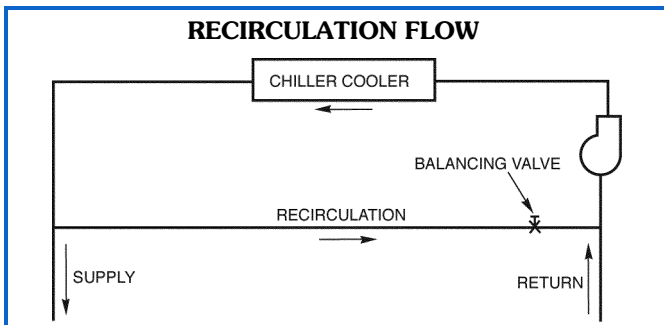

Maximum cooler flow — The maximum cooler flow (approximately 3°F [1.7°C] rise) results in a practical maximum pressure drop through cooler.

Return fluid may bypass the cooler to keep the pressure drop through the cooler within acceptable limits. This permits a higher delta T with lower fluid flow through cooler and mixing after the cooler.

NOTE: Bypass flow is shown below.

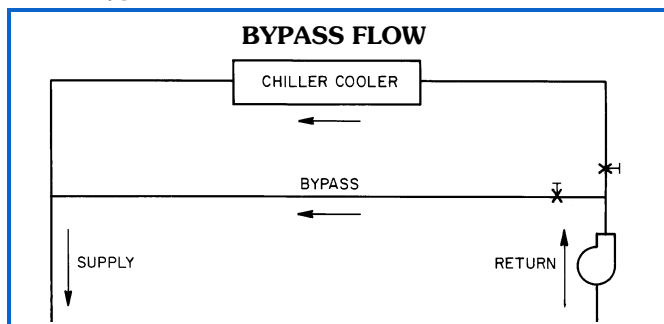

Variable cooler flow rates

Variable flow rates may be applied to a standard chiller. The unit will, however, attempt to maintain a constant leaving chilled water temperature. In such cases, the minimum flow

must be in excess of the minimum flow given in the Minimum and Maximum Cooler Fluid Flow Rates table, adjusted for any glycol in the system, and the minimum fluid volume must be in excess of 3 gallons per ton (3.2 L per kW). The flow rate must change at a rate less than 10% per minute. Apply a minimum of 6 gallons per ton (6.5 L per kW) water loop volume if the flow rate changes more rapidly.

The 30XA chiller is available without a hydronic pumping package or with either of 2 variations of a hydronic pumping package. One of these hydronic options offers a constant-speed pumping package, and the other offers a variable-speed drive. Traditional pumping systems incorporate constant speed drives and waste energy by relying upon throttling valves as the only means to control flow. A more energy-efficient approach to this issue is to use a variable-speed drive. The 30XA chiller is now available with an optional variable-speed hydronic package with sensorless technology to meet this market requirement.

The major cost of a pump over its lifetime will be energy consumption and maintenance, and both of these factors will be reduced using variable-speed pumping. Energy is saved by the combination of lowering the pump speed in conjunction with the resulting lowering of pumping system resistance when conditions permit. Maintenance benefits from the sensorless pumping system include the lack of the need to maintain remote sensors as well as the beneficial effects of lower speed/pressure on the pump and pump bearings.

Another advantage associated with variable-speed pumping is reduced system noise in part load operation when the pump is running at lower speeds. The variable-speed pump package offered on the 30XA chiller is offered both in single and dual-pump designs. In the dual pump case, in which one pump is the backup of the other, each pump connection is fitted with an isolation valve which allows one pump to be isolated for service with the other pump still operating.

As already mentioned, the 30XA variable-speed hydronic package employs sensorless technology. The term "sensorless" means that no remote sensors are required for pump operation. The sensorless pump control monitors system requirements from pump speed and power. The hydronic unit is provided with a pre-defined control curve to automatically adjust speed at all operating conditions. Pump performance and characteristic curves for multiple speeds are programmed into the speed-controller memory. The pre-programmed information includes power, pressure and flow throughout the entire range of the pump. During chiller operation, the power and speed of the pump are monitored. This enables the controller to establish the hydraulic performance, and to position the pump's head-flow characteristic. Although this curve is pre-defined, it is also fully field adjustable. The pump has a graphical user interface, and the graphic keypad can also be used to allow manual pump speed control.

This variable-speed pumping system easily connects to BMS (building management system) systems (BACnet is standard, and LON can be obtained via special order). The pumps may be controlled directly by the BMS system. The

sensorless feature can also be switched off to allow the use of either a 0 to 10 vdc signal or a 0 to 20 mA signal.

For multiple chiller applications employing the variable-speed pumping package, such as chillers operated in a parallel arrangement, the drives must be connected by control wiring and set up to run at the same speed. This is to prevent surging or hunting of the speed set point. One drive will act as the master while the other slave drive will run at the same speed. The master drive may be controlled by a 0 to 10 vdc signal, a 0 to 20 mA signal, or a BMS. The drive must be configured to not use the sensorless function in this arrangement.

A typical example of a chiller operating with a variable-speed pumping system would be the case when the user requires the chiller to operate with a constant fluid temperature difference as the load is reduced. This can be accomplished with the 30XA variable-speed pumping package with the understanding that the flow must never go below the minimum allowable value (see Minimum and Maximum Cooler Flow Rates table on page 122). Once that limit is reached, the flow cannot be further reduced. To accomplish this purpose, the minimum speed of the drive is pre-set based upon the chiller size that is being employed.

As a specific example, let us say the schedule calls for a 100-ton, fresh-water chiller, and it is desired to have a constant 10-degree temperature difference in part load operation (say 54 to 44°F). The schedule calls for 240 gpm at full load based upon the desired capacity and the fluid temperature difference. A constant temperature difference in part load operation is essentially the same as providing flow in direct proportion to chiller load. In the present example, this means that 100% load will run at the scheduled 240 gpm, 90% load will be 216 gpm, etc. down to the minimum allowable flow for this unit size, which, in the case of a 30XA100 (at standard cooler pass), is 101 gpm. The chiller in this example will therefore be able to run down to approximately 42% load while basically maintaining a constant 10 degree fluid temperature difference, and then the flow will be held constant for all lower loads. Throughout the range in which flow is reduced (down to minimum allowable flow), the pump speed is proportionally reduced, resulting in pump energy savings.

Fluid loop volume

The volume in circulation must equal or exceed 3 gal. per nominal ton (3.2 l/kW) of cooling for temperature stability and accuracy in normal air conditioning applications. In process cooling applications, or for operation at ambient temperature below 32°F (0°C) with low loading conditions, there should be from 6 to 10 gal. per ton (6.5 to 10.8 l/kW). To achieve this volume, it is often necessary to install a tank in the loop.

Tank should be baffled to ensure there is no stratification and that water (or brine) entering tank is adequately mixed with liquid in the tank.

The piping between the chiller and the fluid loop volume tank can be done to allow the tank to be on the return side of the chiller (tank piped to chiller inlet) or the supply side of the chiller (tank piped to the chiller outlet). However, it is recommended that the tank be piped to the return side of

the chiller to buffer any changes in load, allowing more stable chiller operation.

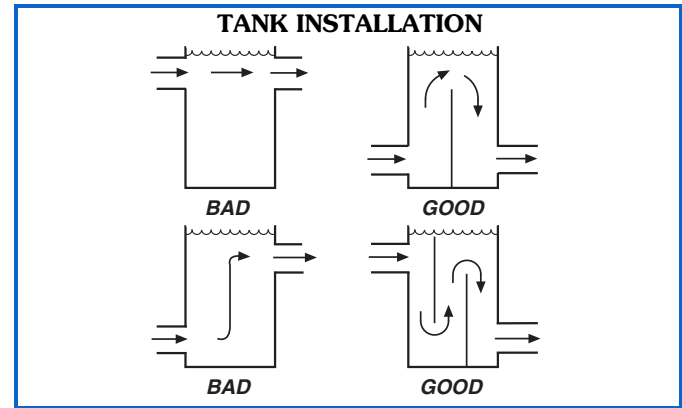

Cooler fouling factor

The fouling factor used to calculate tabulated ratings is $0.0001 \text{ ft}^2 \cdot \text{hr} \cdot \text{°F}/\text{Btu}$ ($0.00018 \text{ m}^2 \cdot \text{°C}/\text{W}$). As fouling factor is increased, both unit capacity and EER decrease. The impact of the fouling factor on performance varies significantly with chiller size and application conditions. Ratings must be determined by the Carrier Selection Program.

Cooler and optional hydronic system freeze protection

Freeze protection for the cooler and the optional hydronic system is standard on all 30XA air-cooled chillers with flooded coolers and optional on chillers with DX coolers. Flooded cooler units are protected from freezing down to 0°F (-18°C) through the cooler heaters (if installed) and control algorithms. If flooded cooler chillers control the chilled water pump/valves, allowing for flow through the cooler, the unit is protected from freezing down to -20°F (-29°C). Chillers equipped with DX cooler and optional heaters are protected from freezing down to -20°F (-29°C). Since power is sometimes lost for extended periods during winter storms, freeze protection provided by heater tapes will be effective only if a back-up power supply can be assured for the unit's control circuit, heater and cooler pump. If not protected with an anti-freeze solution, draining the cooler and outdoor piping is recommended if the system will not be used during freezing weather conditions.

Consider both leaving water set point and ambient freeze conditions when determining antifreeze concentration. Both of these parameters can help determine the recommended concentration level. Higher concentration must be used to adequately protect the machine.

NOTE: Use only antifreeze solutions approved for heat exchanger duty.

For applications in which the leaving fluid temperature set point is less than 40°F (4.4°C), a suitable inhibited antifreeze solution must be used. The solution concentration must be sufficient to protect the chilled water loop to a freeze protection (first crystals) concentration of at least 15°F (8.3°C) below the leaving fluid temperature set point.

If the chiller refrigerant or fluid lines are in an area where ambient conditions fall below 34°F (1.1°C), it is highly recommended that an antifreeze solution be added to protect

Application data (cont)



the unit and fluid piping to a temperature of 15°F (8.3°C) below the lowest anticipated ambient temperature.

Select concentration based on either burst or freeze protection as dictated by the application. If the chiller does not operate during the winter, and a start-up is not expected, a burst protection concentration is recommended. This concentration may not be high enough to pump the fluid through the unit. Burst protection is typically a lower concentration that will provide better performance from the machine. If the chiller does operate during winter, a

freeze protection concentration is recommended. This concentration will be high enough to keep the fluid in a condition that it can be pumped at low ambient conditions.

IMPORTANT: Glycol antifreeze solutions are highly recommended since heater tapes provide no protection in the event of a power failure.

Consult glycol fluid manufacturers for burst protection recommendations and fluid specifications.

MINIMUM AND MAXIMUM COOLER FLOW RATES

ITEM					MINIMUM		MAXIMUM	
Cooler Leaving Water Temperature*					40°F (4.4°C)		60°F (15°C)	
Cooler Entering Water Temperature†					45°F (7.2°C)		70°F (21.1°C)	
30XA UNIT SIZE	Nominal Flow Rate		Cooler	Number of Passes	Minimum Flow Rate**		Maximum Flow Rate	
	(gpm)	(L/s)			(gpm)	(L/s)	(gpm)	(L/s)
080	180.4	11.4	Standard, Flooded	2	95	6.0	379	23.9
			Plus One Pass, Flooded	3	43	2.7	192	12.1
			Minus One Pass, Flooded	1	196	12.4	782	49.3
082	172.8	10.9	DX Cooler	—	86	5.4	346	21.8
090	201.9	12.7	Standard, Flooded	2	101	6.4	403	25.4
			Plus One Pass, Flooded	3	43	2.7	200	12.6
			Minus One Pass, Flooded	1	229	14.4	917	57.9
092	193.7	12.2	DX Cooler	—	97	6.1	387	24.4
100	225.5	14.2	Standard, Flooded	2	101	6.4	403	25.4
			Plus One Pass, Flooded	3	43	2.7	200	12.6
			Minus One Pass, Flooded	1	229	14.4	917	57.9
102	214.3	13.5	DX Cooler	—	107	6.7	429	27.0
110	244.9	15.5	Standard, Flooded	2	125	7.9	501	31.6
			Plus One Pass, Flooded	3	61	3.8	244	15.4
			Minus One Pass, Flooded	1	254	16.0	1014	64.0
112	235.2	14.8	DX Cooler	—	118	7.4	470	29.6
120	264.8	16.7	Standard, Flooded	2	125	7.9	501	31.6
			Plus One Pass, Flooded	3	73	4.6	293	18.5
			Minus One Pass, Flooded	1	281	17.7	1124	70.9
122	254.7	16.0	DX Cooler	—	127	8.0	509	32.1
140	317.8	20.1	Standard, Flooded	2	134	8.5	538	33.9
			Plus One Pass, Flooded	3	73	4.6	293	18.5
			Minus One Pass, Flooded	1	324	20.4	1296	81.8
142	303.5	19.1	DX Cooler	—	152	9.6	607	38.2
160	365.1	23	Standard, Flooded	2	165	10.4	660	41.6
			Plus One Pass, Flooded	3	98	6.2	391	24.7
			Minus One Pass, Flooded	1	354	22.3	1418	89.5
162	347	21.9	DX Cooler	—	174	10.9	694	43.7

*For applications requiring cooler leaving water temperature operation at less than 40°F (4.4°C), the units require the use of antifreeze. Contact your local Carrier representative for more information.

†For applications requiring cooler entering water temperature operation at less than 45°F (7.2°C), contact your local Carrier representative for unit selection using the Carrier electronic catalog.

**For minimum cooler flow rate with brine applications, refer to E-CAT software performance tables.

NOTES:

1. The 30XA units will start and pull down with loop temperatures up to 95°F (35°C).
2. Nominal flow rates required at AHRI conditions 44°F (7°C) leaving fluid temperature, 54°F (12°C) entering water temperature, 95°F (35°C) ambient. Fouling factor 0.00010 ft²-hr-F/Btu (0.0176 (m² · °C/kW)).
3. To obtain proper temperature control, cooler loop fluid volume must be at least 3 gal/ton (3.23 L/kW) of chiller nominal capacity for air conditioning and at least 6 gal/ton (6.5 L/kW) for process applications or systems that must operate in low ambient temperatures (below 32°F [0°C]).

MINIMUM AND MAXIMUM COOLER FLOW RATES (cont)

ITEM				MINIMUM		MAXIMUM		
Cooler Leaving Water Temperature*				40°F (4.4°C)		60°F (15°C)		
Cooler Entering Water Temperature†				45°F (7.2°C)		70°F (21.1°C)		
30XA UNIT SIZE	Nominal Flow Rate		Cooler	Number of Passes	Minimum Flow Rate**		Maximum Flow Rate	
	(gpm)	(L/s)			(gpm)	(L/s)	(gpm)	(L/s)
180	409.6	25.8	Standard, Flooded	2	202	12.7	807	50.9
			Plus One Pass, Flooded	3	73	4.6	391	24.7
			Minus One Pass, Flooded	1	416	26.2	1662	104.9
182	401.7	25.3	DX Cooler	—	201	12.6	803	50.6
200	463.9	29.3	Standard, Flooded	2	223	14.1	892	56.3
			Plus One Pass, Flooded	3	98	6.2	391	24.7
			Minus One Pass, Flooded	1	458	28.9	1833	115.6
202	447.1	28.2	DX Cooler	—	224	14.1	894	56.3
220	505.9	31.9	Standard, Flooded	2	235	14.8	941	59.4
			Plus One Pass, Flooded	3	122	7.7	489	30.9
			Minus One Pass, Flooded	1	501	31.6	2004	126.4
222	493	31.1	DX Cooler	—	246	15.5	950	59.9
240	545.8	34.4	Standard, Flooded	2	266	16.8	1063	67.1
			Plus One Pass, Flooded	3	147	9.3	587	37.0
			Minus One Pass, Flooded	1	538	33.9	2151	135.7
242	530	33.5	DX Cooler	—	265	16.7	950	59.9
260	600.3	37.9	Standard, Flooded	2	257	16.2	1027	64.8
			Plus One Pass, Flooded	3	141	8.9	562	35.5
			Minus One Pass, Flooded	1	584	36.8	2334	147.3
262	583	36.8	DX Cooler	—	292	18.4	950	59.9
280	642.2	40.5	Standard, Flooded	2	293	18.5	1173	74.0
			Plus One Pass, Flooded	3	141	8.9	562	35.5
			Minus One Pass, Flooded	1	620	39.1	2481	156.5
282	627	39.5	DX Cooler	—	313	19.8	950	59.9
300	687.5	43.4	Standard, Flooded	2	327	20.6	1308	82.5
			Plus One Pass, Flooded	3	174	11.0	697	44.0
			Minus One Pass, Flooded	1	687	43.3	2750	173.5
302	665	42.0	DX Cooler	—	333	21.0	1331	83.9
325	733.4	46.3	Standard, Flooded	2	361	22.8	1442	91.0
			Plus One Pass, Flooded	3	211	13.3	843	53.2
			Minus One Pass, Flooded	1	724	45.7	2897	182.8
327	720	45.4	DX Cooler	—	360	22.7	1440	90.8
350	775.4	48.9	Standard, Flooded	2	379	23.9	1516	95.6
			Plus One Pass, Flooded	3	244	15.4	978	61.7
			Minus One Pass, Flooded	1	767	48.4	3068	193.6
352	757	47.8	DX Cooler	—	379	23.9	1514	95.5
401	948	59.9	Standard, Flooded	2	474	29.9	1896	119.6
			Plus One Pass, Flooded	—	—	—	—	—
			Minus One Pass, Flooded	1	800	50.5	3792	239.3
451	1047	66.1	Standard, Flooded	2	524	33.0	2094	132.1
			Plus One Pass, Flooded	—	—	—	—	—
			Minus One Pass, Flooded	1	800	50.5	4000	252.4
476	1104	69.7	Standard, Flooded	2	552	34.8	2208	139.3
			Plus One Pass, Flooded	—	—	—	—	—
			Minus One Pass, Flooded	1	950	59.9	4000	252.4
501	1184	74.7	Standard, Flooded	2	592	37.3	2368	149.4
			Plus One Pass, Flooded	—	—	—	—	—
			Minus One Pass, Flooded	1	950	59.9	4000	252.4

*For applications requiring cooler leaving water temperature operation at less than 40°F (4.4°C), the units require the use of antifreeze. Contact your local Carrier representative for more information.

†For applications requiring cooler entering water temperature operation at less than 45°F (7.2°C), contact your local Carrier representative for unit selection using the Carrier electronic catalog.

**For minimum cooler flow rate with brine applications, refer to E-CAT software performance tables.

NOTES:

1. The 30XA units will start and pull down with loop temperatures up to 95°F (35°C).
2. Nominal flow rates required at AHRI conditions 44°F (7°C) leaving fluid temperature, 54°F (12°C) entering water temperature, 95°F (35°C) ambient. Fouling factor 0.00010 ft²-hr-F/Btu (0.0176 m² · °C/kW).
3. To obtain proper temperature control, cooler loop fluid volume must be at least 3 gal/ton (3.23 L/kW) of chiller nominal capacity for air conditioning and at least 6 gal/ton (6.5 L/kW) for process applications or systems that must operate in low ambient temperatures (below 32°F [0°C]).

High ambient temperature operation

High outdoor ambient chiller start-up and operation is possible for standard 30XA chillers at ambient temperatures up to 125.6°F (52°C) at nominal voltage, and up to 131°F (55°C) for size 401-501 units. For applications approaching these temperatures, it may be advisable to select the high ambient temperature option to increase fan airflow. The high ambient temperature option is standard for 30XA401-501 chillers, and it is not available for unit sizes 30XA080-122.

Low ambient temperature operation

Units will start and operate down to 32°F (0°C) as standard. Operation to -20°F (-29°C) requires optional low ambient head pressure control as well as wind baffles (field fabricated and installed to all units for operation below 32°F [0°C]). Inhibited propylene glycol or other suitable corrosion-resistant antifreeze solution must be field supplied and installed in all units for unit operation below 34°F (1.1°C). Solution must be added to fluid loop to protect loop down to 15°F (8.3°C) below minimum operating ambient temperature. Concentration should be based on expected minimum temperature and either “Burst” or “Freeze” protection levels. At least 6 gal. per ton (6.5 l/kW) of water volume is the recommended minimum for a moderate system load.

Altitude correction factors

Correction factors must be applied to standard ratings at altitudes above 2000 ft (609.6 m) using the following multipliers:

ALTITUDE CORRECTION FACTORS

ALTITUDE		CAPACITY MULTIPLIER	COMPRESSOR POWER MULTIPLIER
(ft)	(m)		
2,000	609.6	0.99	1.01
4,000	1219.2	0.98	1.02
6,000	1828.8	0.97	1.03
8,000	2438.4	0.96	1.04
10,000	3048.0	0.95	1.05

Condenser airflow — Airflow restrictions on units with standard fans will affect the unit capacity, condenser head pressure, and compressor power input. Correction factors to be applied for external static restrictions up to 0.2 in. wg (50 Pa) are as follows:

EXTERNAL STATIC		CAPACITY MULTIPLIER	COMPRESSOR POWER MULTIPLIER
in. wg	Pa		
0.0	0.0	1.000	1.00
0.1	25	0.986	1.01
0.2	50	0.968	1.03

Multiple chillers

Where chiller capacities greater than can be supplied by a single 30XA chiller are required or where standby capability is desired, standard flooded cooler chillers may be installed in parallel or series, whereas chillers with the DX cooler option may be installed in parallel. Units may be of the same or different sizes with this piping arrangement. However, for parallel chiller applications, cooler flow rates must be balanced to ensure proper flow to each chiller.

Unit software is capable of controlling two units as a single plant by making use of the dual chiller control feature. Refer

to the Controls, Start-up, Operation, Service and Troubleshooting guide for further details. The accessory Chillervisor System Manager can be used to ensure proper staging sequence of up to 8 chillers in parallel. Refer to the accessory Chillervisor System Manager installation instructions for further details.

If the dual chiller algorithm is used and the machines are installed in parallel, an additional chilled water sensor must be installed for each chiller (to provide the required hardware, a dual chiller accessory kit is available from the factory). Install one thermistor and well per chiller in the common leaving water header. Chillers installed in series do not require additional sensors.

Parallel chiller control with dedicated pumps is recommended. The chiller must start and stop its own water pump located in its own piping. Check valves are required at the discharge of each pump (*when the factory hydronic package option is chosen, and dual pumps are selected, the check valves are automatically supplied*). If pumps are not dedicated for each chiller, then isolation valves are required. Each chiller must open and close its own isolation valve through the unit control (the valve must be connected to the pump outputs).

Hydronic pump packages may not be applied in series applications. Refer to the chiller piping configurations shown in the parallel dual chiller operation figure, page 125.

Dual chiller control

The *ComfortLink* controller allows 2 chillers (piped in parallel or series) to operate as a single chilled water plant with standard control functions coordinated through the master chiller controller. This standard *ComfortLink* feature requires a communication link between the 2 chillers.

There are several advantages to this type of control:

- Redundancy (multiple circuits)
- Better low load control (lower tonnage capability)
- Lower rigging lift weights (2 machines rather than one large machine)
- Chiller lead-lag operation (evens the wear between the two machines)

Condenser coil protection (*Enviro-Shield™*)

Refer to the environmental selection guides for more information. If the standard Novation® (microchannel) coil does not meet the corrosion requirements for a given application, additional coil options are available. For specific geographical recommendations, please refer to the NACO Packaged Chiller Builder program.

Aluminum fin/copper tube coils are constructed of seamless copper tubes mechanically bonded to aluminum fins. The fins have wavy enhancements. These condenser coils are recommended with remote cooler applications. These coils are not recommended for corrosive environments.

PARALLEL DUAL CHILLER OPERATION (FLOODED COOLER SHOWN)

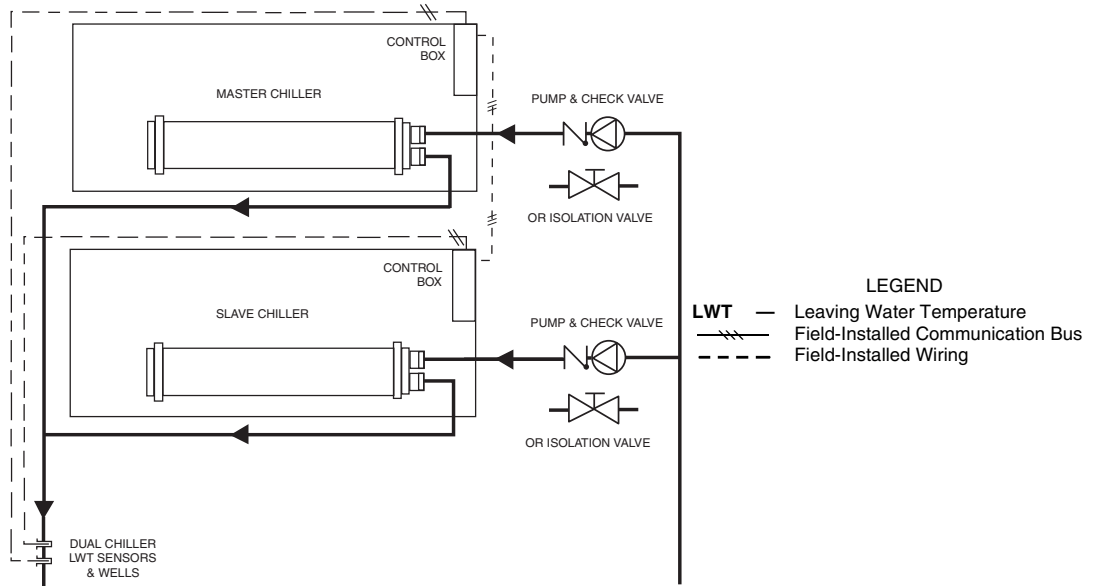

SERIES DUAL CHILLER OPERATION (FLOODED COOLER SHOWN)

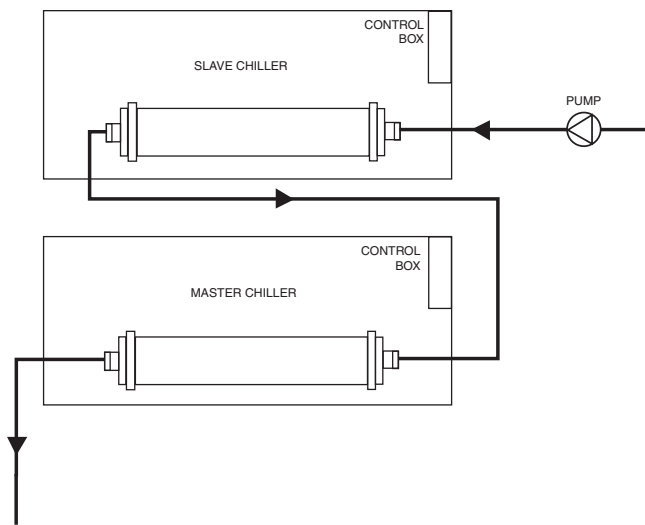

Pre-coated aluminum-fin coils have a durable epoxy-phenolic coating applied to the fin prior to the fin stamping process to provide protection in mildly corrosive coastal environments. Pre-coated coils have an inert barrier between the aluminum fin and copper tube. This barrier electrically disconnects the dissimilar metals to minimize the potential for galvanic corrosion. This economical

option provides substantial corrosion protection beyond the standard uncoated coil construction.

Copper-fin coils provide increased corrosion resistance compared to aluminum fin coils. All-copper coils eliminate bimetallic construction to eliminate the potential for galvanic corrosion. Application in industrial environments is not recommended due to potential attack from sulfur, sulfur oxide, nitrogen oxides, carbon and several other indus-

E-coated Novation® coils have an extremely flexible and durable epoxy coating uniformly applied to all coil surfaces. Unlike brittle phenolic dip and bake coatings, e-coat provides superior protection with unmatched flexibility, edge coverage, metal adhesion, thermal performance and most importantly, corrosion resistance. E-coated coils provide this protection since all coil surfaces are completely encapsulated from environmental contamination. This option provides the best protection for Novation coil technology. E-coated aluminum microchannel coils shall be capable of withstanding an 8000-hour salt spray test in accordance with the ASTM (American Society for Testing and Materials) (U.S.A.) B-117 Standard.

E-coated aluminum-fin coils have the same flexible and durable epoxy coating as e-coated Novation coils. This option provides better protection compared to standard or pre-coated aluminum-fin coils in many environments.

E-coated copper-fin coils have the same flexible and durable epoxy coating as other e-coated coils. However, this option combines the natural salt and environmental resistance of all-copper construction with the highest level of corrosion protection within the round-tube, plate-fin type of coils.

Optional hydronic system selection

Select pump flow from resulting chiller selection and total pressure loss in the system plus the chiller internal pressure loss.

NOTE: Maximum flow (gpm [L/s]), pressure and pump hp must not exceed maximum indicated on pump curve.

NOTE: Optional hydronic system is available in both constant-speed and VFD configurations, as described in the Variable Cooler Flow Rates section. This option is available on sizes 090-162 only, and never in combination with high SCCR.

Pump flow can be reduced by using the factory-supplied combination valve up to 10%. Beyond that, impeller trimming is recommended to reduce energy consumption. Follow local codes or ASHRAE 90.1 recommendations. Contact your Carrier representative for the specific amount of trim required.

The AquaForce® 30XA chiller will require a field-supplied expansion tank when the optional pump package is provided.

The expansion tank is based on fluid type, temperature range, fluid pressure and loop volume.

Parallel chillers with hydronic packages require that pump inlets be equalized to prevent pump cavitation. If more than one expansion tank is to be used in the chiller water loop, the expansion tanks must be located together in the common pump suction header. If expansion tank relocation is required for parallel chiller configuration, all materials needed for expansion tank relocation are field supplied. Appropriate measures must be taken for freeze protection.

NOTE: It is recommended for units with the hydronic package that an inlet isolation (shutoff) valve be placed exterior to the unit to allow removal and service of the entire pump assembly, if necessary. The hydronic package

is supplied from the factory with a combination valve for isolation of leaving water. Also, if the unit is isolated with valves, a properly sized pressure relief valve is recommended and should be installed in the piping between the unit and the valves, following all applicable local codes.

Air separation

For proper system operation, it is essential that water loops be installed with proper means to manage air in the system. Free air in the system can cause noise, reduce terminal output, stop flow, or even cause pump failure due to pump cavitation. For closed systems, equipment should be provided to eliminate all air from the system.

The amount of air that water can hold in solution depends on the pressure and temperature of the water/air mixture. Air is less soluble at higher temperatures and at lower pressures. Therefore, separation can best be done at the point of highest water temperature and lowest pressure. Typically, this point would be on the suction side of the pump as the water is returning from the system or terminals. This is generally the optimal place to install an air separator, if possible.

Install automatic air vents at all high points in the system. (If the 30XA unit is located at the high point of the system, a vent can be installed on the piping leaving the heat exchanger on the 1/4 in. NPT female port.)

Install an air separator in the water loop, at the place where the water is at higher temperatures and lower pressures — usually in the chilled water return piping. On a primary-secondary system, the highest temperature water is normally in the secondary loop, close to the decoupler. Preference should be given to that point on the system. In-line or centrifugal air separators are readily available in the field.

It may not be possible to install air separators at the place of the highest temperature and lowest pressure. In such cases, preference should be given to the points of highest temperature. It is important that the pipe be sized correctly so that free air can be moved to the point of separation. Generally, a water velocity of at least 2 feet per second (0.6 m per second) will keep free air entrained and prevent it from forming air pockets.

Automatic vents should be installed at all physically elevated points in the system so that air can be eliminated during system operation. Provisions should also be made for manual venting during the water loop fill.

IMPORTANT: Automatic vents should be located in accessible locations for maintenance purposes and protected from freezing.

Electrical/utility interests

Energy management — Use of energy management practices can significantly reduce operating costs, especially during off-peak modes of operation. Demand limiting and temperature reset are two techniques for accomplishing efficient energy management. See Demand Limiting (also called load shedding) section below for further details.

Demand limiting (load shedding)

When a utility's demand for electricity exceeds a certain level, loads are shed to keep electricity demand below a prescribed maximum level. Typically, this happens on hot days when air conditioning is most needed. The energy management module (EMM) can be added to accomplish this reduction. Demand may be limited on the unit by resetting water temperature, or by unloading the chiller to a given predetermined percentage of the load. Demand limit may also be driven by an external 4 to 20 mA signal. These features require a signal from an intelligent central control. Do not cycle demand limiter for less than 10 minutes on and 5 minutes off. Duty cycling cycles electrical loads at regular intervals regardless of need. This reduces the electrical operating costs of building by "fooling" demand indicating devices. Duty cycling of compressors or fans is not recommended since motor winding and bearing life will suffer from constant cycling.

Remote on-off control

Remote on-off control may be applied by hard-wired connection (see Controls and Troubleshooting literature) or by connection to the Carrier Comfort Network® (CCN) system.

Minimum time to power chiller before start-up

In order to ensure that the oil sump heaters are provided sufficient time to raise the oil sump temperature to the required operating point, power must be applied to the control circuit a minimum of 24 hours prior to chiller start-up. On 30XA chillers, the control circuit obtains its power either from a direct 115-V, single-phase power source or from an optional control transformer on the main 3-phase power supply.

Outdoor Air-Cooled Liquid Chiller

HVAC Guide Specifications

Size Range: **80 to 500 Tons, Nominal**
(265 to 1740 kW, Nominal)

Carrier Model Number: **30XA**

Part 1 — General

1.01 SYSTEM DESCRIPTION

Microprocessor controlled, air-cooled liquid chiller for outdoor installation, utilizing screw compressors and low sound fans.

1.02 QUALITY ASSURANCE

- A. Unit shall be rated in accordance with AHRI (Air-Conditioning, Heating, and Refrigeration Institute) Standard 550/590 (U.S.A.) latest edition and all units shall be ASHRAE (American Society of Heating, Refrigerating, and Air-Conditioning Engineers) 90.1 compliant.
- B. Unit construction shall comply with ASHRAE 15 Safety Code, UL (Underwriters Laboratories) 1995, and ASME (American Society of Mechanical Engineers) applicable codes (U.S.A. codes).
- C. The management system governing the manufacture of this product is ISO (International Organization for Standardization) 9001:2008 certified.
- D. Unit shall be full load run tested at the factory.

1.03 DELIVERY, STORAGE AND HANDLING

- A. Unit controls shall be capable of withstanding 150°F (65.5°C) storage temperatures in the control compartment.
- B. Unit shall be stored and handled per unit manufacturer's recommendations.

Part 2 — Products

2.01 EQUIPMENT

A. General:

Factory assembled, single-piece chassis, air-cooled liquid chiller. Contained within the unit cabinet shall be all factory wiring, piping, controls, refrigerant charge (R-134a), and special features required prior to field start-up.

B. Materials of Construction:

1. The base rail is industrial-quality, 7 ga, zinc-dipped galvanized frame (with Magni-coated screws).
2. Cabinet shall be galvanized steel casing with a baked enamel powder or pre-painted finish.
3. Cabinet shall be capable of withstanding 500-hour salt spray test in accordance with the ASTM (American Society for Testing and Materials) (U.S.A.) B-117 standard.

C. Fans:

1. Condenser fans shall be direct-driven, 9-blade airfoil cross-section, reinforced polymer construction, shrouded-axial type, and shall be statically and dynamically balanced with inherent corrosion resistance.

2. Air shall be discharged vertically upward.
3. Fans shall be protected by coated steel wire safety guards.

D. Compressor/Compressor Assembly:

1. Comprised of semi-hermetic twin screw type compressors.
2. Compressor motor shall be direct drive, 3500 rpm, protected by motor temperature sensors, suction gas cooled motor.
3. Capacity control shall utilize an infinitely modulating slide valve to modulate capacity from 100% to 15% full load.

E. Flooded Cooler:

1. Shall be a mechanically cleanable tubes in a shell-and-tube type cooler with removable heads.
2. Tubes shall be internally enhanced seamless-copper type rolled into tube sheets.
3. Shall be equipped with Victaulic-type water connections.
4. Shell and cooler heads shall be insulated with 3/4-in. PVC foam (closed-cell) with a maximum K factor of 0.28.
5. Design shall incorporate 2 independent refrigerant circuits.
6. Cooler shall be tested and stamped in accordance with ASME Code for a refrigerant working side pressure of 220 psig (1517 kPa). Cooler shall have a maximum water-side pressure of 300 psig (2068 kPa).
7. Cooler shall have a cooler drain and vent.
8. Low-ambient temperature protection: unit shall have factory-installed cooler heater (where applicable), and pumpout cycle to protect cooler from ambient temperature freeze down to 0°F (-17.8°C).
9. Cooler shall be provided with a factory-installed flow switch.

F. Condenser:

1. Coil shall be air-cooled Novation® heat exchanger technology (MCHX) and shall have a series of flat tubes containing a series of multiple, parallel flow microchannels layered between the refrigerant manifolds. Novation coils shall consist of a two-pass arrangement. Coil construction shall consist of aluminum alloys for fins, tubes, and manifolds in combination with a corrosion-resistant coating.
2. Tubes shall be cleaned, dehydrated, and sealed.
3. Assembled condenser coils shall be pressure tested at the coil factory at 660 psig (5448 kPa) and subsequently shall be leak tested at 145 psig ±5 psig (1000 kPa ±34.5 kPa) and pressure tested at 350 psig (2413 kPa) at final unit assembly.
- 4. To plan the chiller installation and for ease of maintenance/coil removal, all refrigerant piping

entering and leaving the condenser coils shall be located on only one side of the chiller so the coils can be removed (when needed) from the side free of piping. This is important to consider because removing the coils from the header side, although possible, involves extra labor due to extra bending and brazing of the coil headers.

G. Refrigeration Components:

Refrigerant circuit components shall include replaceable-core filter drier, moisture indicating sight glass, electronic expansion valve, discharge service valves and liquid line service valves, and complete operating charge of both refrigerant R-134a and compressor oil.

H. Controls, Safeties, and Diagnostics:

1. Unit controls shall include the following minimum components:

- a. Microprocessor with non-volatile memory. Battery backup system shall not be accepted.
- b. Separate terminal block for power and controls.
- c. Separate 115-v power supply to serve all controllers, relays, and control components.
- d. ON/OFF control switch.
- e. Replaceable solid-state controllers.
- f. Pressure sensors installed to measure suction, oil, economizer, and discharge pressure. Thermistors installed to measure cooler entering and leaving fluid temperatures and outside air temperature.

2. Unit controls shall include the following functions:

- a. Automatic circuit lead/lag.
- b. Capacity control based on leaving chilled fluid temperature and compensated by rate of change of return-fluid temperature with temperature set point accuracy to 0.1°F (0.05°C).
- c. Limiting the chilled fluid temperature pull-down rate at start-up to an adjustable range of 0.2°F to 2°F (0.1 to 1.1°C) per minute to prevent excessive demand spikes at start-up.
- d. Seven-day time schedule.
- e. Leaving chilled fluid temperature reset from return fluid and outside air temperature.
- f. Chilled water pump start/stop control.
- g. Chiller control for parallel chiller applications without addition of hardware modules and control panels (requires thermistors).
- h. Timed maintenance scheduling to signal maintenance activities for strainer maintenance and user-defined maintenance activities.
- i. Low ambient protection to energize cooler heaters (if installed).
- j. Single step demand limit control activated by remote contact closure.
- k. Periodic pump start to ensure pump seals are properly maintained during off-season periods.

1. Night time sound mode to reduce the sound of the machine by a user-defined schedule.

3. Diagnostics:

a. The control panel shall include, as standard, a display:

- 1) Touch screen display consisting of 1/4 VGA LCD (liquid crystal display) with adjustable contrast and backlighting.
- 2) Display shall allow a user to navigate through menus, select desired options and modify data.

b. Features of the display shall include:

- 1) Display shall be customizable and allow up to 72 data points.
- 2) Display shall support both local equipment or network made for remote mount.
- 3) Display shall allow access to configuration, maintenance, service, set point, time schedules, alarm history and status data.
- 4) Display shall have one button for chiller on/off.
- 5) Display shall include three levels of password protection against unauthorized access to configuration and maintenance information, and display set up parameters.
- 6) Display shall allow for easy connection of a portable hand held technician tool to access information and upload and/or download chiller settings.
- 7) Display shall be compatible with the Carrier Comfort Network® (CCN) system and provide network alarm acknowledgment or indication and provide capability to fully monitor and control chiller.
- 8) Display alarms and parameters shall be capable of being displayed in full text.
- 9) Display shall be capable of displaying the last 50 alarms and will store a snapshot of a minimum of 20 status data parameters for each alarm.
- 10) Compressor run hours.
- 11) Compressor number of starts.
- 12) Compressor current.
- 13) Time of day:
 - a) Display module, in conjunction with the microprocessor, must also be capable of displaying the output (results) of a service test. Service test shall verify operation of every switch, thermistor, fan, and compressor before chiller is started.
 - b) Diagnostics shall include the ability to review a list of the 30 most recent alarms with clear language descriptions of the alarm event. Display of alarm codes without the ability for

clear language descriptions shall be prohibited.

- c) An alarm history buffer shall allow the user to store no less than 30 alarm events with clear language descriptions, time and date stamp event entry.
- d) The chiller controller shall include multiple connection ports for communicating with the local equipment network, the Carrier Comfort Network® (CCN) system and the ability to access all chiller control functions from any point on the chiller.
- e) The control system shall allow software upgrade without the need for new hardware modules.

4. Safeties:

a. Unit shall be equipped with thermistors and all necessary components in conjunction with the control system to provide the unit with the following protections:

- 1) Loss of refrigerant charge.
- 2) Reverse rotation.
- 3) Low chilled fluid temperature.
- 4) Motor overtemperature.
- 5) High pressure.
- 6) Electrical overload.
- 7) Loss of phase.
- 8) Loss of chilled water flow.

b. Condenser-fan motors shall have internal overcurrent protection.

I. Operating Characteristics:

- 1. Unit shall be capable of starting and running at outdoor ambient temperatures from 32°F (0°C) to 125.6°F (52°C) for all sizes.
- 2. Unit shall be capable of starting up with 95°F (35°C) entering fluid temperature to the cooler.

J. Motors:

Condenser-fan motors shall be totally enclosed, air over, single speed, 3-phase type with permanently lubricated bearings and Class F insulation.

K. Electrical Requirements:

- 1. Unit primary electrical power supply shall enter the unit at a single location (all chiller voltage/size combinations shall have the ability to accommodate 2 power supplies to meet job-specific requirements).
- 2. Primary electrical power supply shall be rated to operate up to 131°F (55°C) for 401-501 units and up to 125°F (52°C) ambient temperature for all other models.
- 3. Unit shall operate on 3-phase power at the voltage shown in the equipment schedule.
- 4. Control points shall be accessed through terminal block.

5. Unit shall be shipped with factory control and power wiring installed.

L. Chilled Water Circuit:

1. Chilled water circuit shall be rated for 300 psig (2068 kPa). Units with optional pump package are rated for 150 psig (1034 kPa) working pressure.

2. Thermal dispersion proof of flow switch shall be factory installed and wired.

3. Optional hydronic package:

a. With or without VFD (variable frequency drive) (30XA090-162 units only, not available with high SCCR [short circuit current rating]):

1) Field pipe connections shall be Victaulic type.

2) Optional single or primary/stand-by operation pump systems. Dual pump systems shall have a pump discharge check valve.

3) Pumps shall be vertical in-line, single stage design, and capable of being serviced without disturbing piping connections.

a) Pump casing shall be of class 30 cast iron.

b) The impeller shall be of cast bronze, closed type, dynamically balanced, keyed to the shaft and secured by locking cap screw.

c) The hydronic kit will be provided with a flush line connection to ensure lubrication at the seal face and allow for positive venting of the seal chamber.

d) Each port shall be fitted with an isolation valve that allow the units to operate in parallel or standby, yet may be used to isolate one pumping unit for servicing or removal with the other pump still running.

e) Pump shall be rated for 150 psig (1034 kPa) working pressure.

f) The pump case shall have gage tapings at the suction and discharge nozzles and include drain ports.

g) Dual pumps shall allow for the servicing of one pump without draining the chilled water loop.

h) Motors shall be premium efficiency, Totally Enclosed Fan Cooled (TEFC) 3-phase type with grease lubricated ball bearings.

i) Each pump shall be factory tested per Hydraulic Institute Standards.

4) Pressure/temperature taps (3) shall be factory installed to measure the pressure differential across the pump and across the strainer.

5) Combination valve (which includes check, isolation, and modulation) shall be factory installed. Pressure/temperature taps (2)

- shall be factory installed to measure the pressure differential across the combination valve.
- 6) Hydronic assembly shall have factory-supplied electric freeze protection to -20°F (-29°C).
 - 7) Piping shall be Schedule 40 black steel.
 - 8) Cast iron or ductile iron body $\frac{1}{8}$ in. perforated strainer. A factory-installed, removable fine mesh start-up strainer for initial run period shall be included. The start-up strainer must be removed within 24 hours after chiller start-up.
- b. With VFD (these comments are applicable in addition to the comments in section a when the VFD hydronic package is employed [30XA090-162 units only]):
- 1) The drive shall be of the voltage vector control - pulse with modulation (VVC-PWM) type, providing near unity displacement power factor without the need for external power factor correction capacitors at all loads and speeds.
 - 2) The drive and motor protection shall include: motor phase to ground fault, loss of supply phase, over voltage, under voltage, motor over temperature, inverter overload, over current. Over current is not allowed, ensuring hydronic units will not overload the motor at any point in the operating range of the unit.
 - 3) Sensorless control software shall be available in the hydronic unit to provide automatic speed control without the need for pump mounted (internal/external) or remotely mounted differential pressure system feedback sensors. Control mode setting and minimum/maximum head set points shall be set at the factory and be user adjustable via the programming interface.
 - 4) The integrated control shall incorporate an integrated graphical user interface that shall provide running and diagnostic information and identify faults and status in clear English language. Faults shall be logged/recorded for review at a later date. It shall be possible to upload parameters from one drive into the non-volatile memory of a computer and download the parameters into other drives requiring the same settings. The key pad shall incorporate Hand-Off-Auto pushbuttons to enable switching between BMS (building management systems) and manual control. The drive shall incorporate a USB port for direct connection to a PC and an RS485 connection with Modbus¹ RTU protocol.

Optional protocols available should include BACnet² and LonWorks³.

- 5) The control shall have the following additional features: Sensorless override for BMS, manual pump control or closed loop PID control; programmable skip frequencies and adjustable switching frequency for noise/vibration control; auto alarm reset; motor pre-heat function; six programmable digital inputs; two analog inputs; one programmable analog/digital output; two volt-free contacts.
- 6) The hydronic unit shall be capable of operating in any of the following control modes:
 - a) Duty pump and standby pumps with sensorless control.
 - b) Duty pump and standby pumps with remote sensor or building system (BAS) control.

M. Special Features:

Certain standard features are not applicable when the features designated by * are specified. For assistance in amending the specifications, contact your Carrier representative.

1. DX (Direct Expansion) Cooler Option (Not Available on sizes 401-501):
 - a. Shell-and-tube type, direct expansion.
 - b. Tubes shall be internally enhanced seamless-copper type rolled into tube sheets.
 - c. Shall be equipped with Victaulic-type water connections.
 - d. Shell shall be insulated with $\frac{3}{4}$ -in. (19 mm) PVC foam (closed-cell) with a maximum K factor of 0.28.
 - e. Design shall incorporate a minimum of 2 independent direct-expansion refrigerant circuits.
 - f. Cooler shall be rested and stamped in accordance with ASME Code for a refrigerant working side pressure of 220 psig (1517 kPa). Cooler shall have a maximum water-side pressure of 300 psig (2068 kPa).
 - g. Cooler shall be provided with a factory-installed flow switch.

* 2. Low Ambient Temperature Head Pressure Control:

Unit shall be capable of running at outdoor ambient temperatures down to -20°F (-29°C) with the addition of antifreeze in the cooler circuit, wind baffles, and field-installed or factory-installed solid-state low ambient temperature head pressure control with condenser coil temperature sensor.

1. Modbus is a registered trademark of Schneider Electric.

2. BACnet is a registered trademark of ASHRAE (American Society of Heating, Refrigerating, and Air-Conditioning Engineers).
3. LonWorks is a registered trademark of Echelon Corporation.

3. Unit-Mounted Non-Fused Disconnect:

Unit shall be supplied with factory-installed, lockable, non-fused electrical disconnect for main power supply. This is not available with the combination of dual point power and high SCCR (short circuit current rating).

4. Optional Condenser Coil Materials:

a. E-coated microchannel coils:

E-coated aluminum microchannel coil shall have a flexible epoxy polymer coating uniformly applied to all coil external surface areas without material bridging between fins or louvers. Coating process shall ensure complete coil encapsulation, including all exposed fin edges. E-coat shall have a thickness of 0.8 to 1.2 mil with top coat having a uniform dry film thickness from 1.0 to 2.0 mil on all external coil surface areas including fin edges. E-coated coils shall have superior hardness characteristics of 2H per ASTM D3363-00 and cross hatch adhesion of 4B-5B per ASTM D3359-02. Impact resistance shall be up to 160 in./lb (ASTM D2794-93). E-coated coil shall have superior impact resistance with no cracking, chipping, or peeling per NSF/ANSI 51-2002 Method 10.2. E-coated aluminum microchannel coils shall be capable of withstanding an 8000-hour salt spray test in accordance with the ASTM (American Society for Testing and Materials) (U.S.A.) B-117 Standard.

b. Aluminum fin/copper-tube coils:

Coil shall be constructed of seamless copper tubes mechanically bonded to aluminum fins. Fins shall have wavy enhancements. These condenser coils are recommended with remote cooler applications. These coils are not recommended for corrosive environments.

c. Pre-coated aluminum-fin coils:

Shall have a durable epoxy-phenolic coating to provide protection in mildly corrosive coastal environments. Coating shall be applied to the aluminum fin stock prior to the fin stamping process to create an inert barrier between the aluminum fin and copper tube. Epoxy-phenolic barrier shall minimize galvanic action between dissimilar metals.

d. Copper-fin coils:

Shall be constructed of copper fins mechanically bonded to copper tubes and copper tube sheets. Galvanized steel tube sheets shall not be acceptable. A polymer strip shall prevent coil assembly from contacting sheet metal coil pan to minimize potential for galvanic corrosion between the coil and pan. All copper construction shall provide protection in moderate coastal applications.

e. E-coated aluminum-fin coils:

Shall have a flexible epoxy polymer coating uniformly applied to all coil surface areas without material bridging between fins. Coating process shall ensure complete coil encapsulation. Color shall be high gloss black with gloss — 60° of 65-90% per ASTM D523-89. Uniform dry film thickness from 0.8 to 1.2 mil on all surface areas including fin edges. Superior hardness characteristics of 2H per ASTM D3363-92A and cross hatch adhesion of 4B-5B per ASTM D3359-93. Impact resistance shall be up to 160 in./lb (ASTM D2794-93). Humidity and water immersion resistance shall be up to minimum 1000 and 250 hours respectively (ASTM D2247-92 and ASTM D870-92). Corrosion durability shall be confirmed through testing to no less than 3000 hours salt spray per ASTM B117-90. Coil construction shall be aluminum fins mechanically bonded to copper tubes.

f. E-coated copper-fin coils:

Shall have a flexible epoxy polymer coating uniformly applied to all coil surface areas without material bridging between fins. Coating process shall ensure complete coil encapsulation. Color shall be high gloss black with gloss — 60° of 65-90% per ASTM D523-89. Uniform dry film thickness from 0.8 to 1.2 mil on all surface areas including fin edges. Superior hardness characteristics of 2H per ASTM D3363-92A and cross hatch adhesion of 4B-5B per ASTM D3359-93. Impact resistance shall be up to 160 in./lb (ASTM D2794-93). Humidity and water immersion resistance shall be up to minimum 1000 and 250 hours respectively (ASTM D2247-92 and ASTM D870-92). Corrosion durability shall be confirmed through testing to no less than 3000 hours salt spray per ASTM B117-90. Coil construction shall be copper-fins mechanically bonded to copper tube sheets. Galvanized steel tube sheets shall not be acceptable. A polymer strip shall prevent coil assembly from contacting sheet metal coil pan to maintain coating integrity and minimize corrosion potential between the coil and pan.

5. Remote Enhanced Display:

Unit shall be supplied with indoor-mounted, remote, 40-character per line, 16-line display panel for field installation.

6. Chillervisor System Manager III Multi-Unit Control:

Field-installed control shall sequence 2 chillers in series, or between 2 and 8 chillers in parallel in a single system.

7. Energy Management Module:

A factory or field-installed module shall provide the following energy management capabilities: 4 to 20 mA signals for leaving fluid temperature reset, cooling set point reset or demand limit control; 2-step demand limit control (from 0% to 100%) activated by a remote contact closure; and discrete input for “Ice Done” indication for ice storage system interface.

8. Condenser Coil Trim Panels:

Unit shall be supplied with field-installed coil covers.

9. BACnet Communication Option:

Shall provide pre-programmed factory-installed communication capability with a BACnet MS/TP network. Allows integration with i-Vu® Open control system or a third-party BACnet building automation system. No field programming shall be required.

10. BACnet/Modbus Translator Control:

Unit shall be supplied with factory or field-installed interface between the chiller and a BACnet Local Area Network (LAN; i.e., MS/TP EIA-485). Field programming shall be required.

11. LON Translator Control:

Unit shall be supplied with factory or field-installed interface between the chiller and a Local Operating Network (LON; i.e., LonWorks FT-10A ANSI/EIA-709.1). Field programming shall be required.

12. Navigator™ hand-held portable display:

- a. Portable hand-held display module with a minimum of 4 lines and 20 characters per line, or clear English, Spanish, Portuguese or French language.
- b. Display menus shall provide clear language descriptions of all menu items, operating modes, configuration points and alarm diagnostics. Reference to factory codes shall not be accepted.
- c. RJ-14 connection plug shall allow display module to be connected to factory-installed receptacle.
- d. Industrial grade coiled extension cord shall allow the display module to be moved around the chiller.
- e. Magnets shall hold the display module to any sheet metal panel to allow hands-free operation.
- f. Display module shall have NEMA 4x housing suitable for use in outdoor environments.
- g. Display shall have backlight and contrast adjustment for easy viewing in bright sunlight or night conditions.
- h. Raised surface buttons with positive tactile response.

13. Touch Pilot™ Display:

Unit shall be supplied with a field-installed, remote-mount, touch screen display for network attachment to the chiller. The Touch Pilot display provides information in clear English, Spanish, Portuguese, or French language.

14. Isolation Valve Option:

Unit shall be supplied with factory-installed isolation valve which provides a means of isolating the compressors from the cooler vessel, which is beneficial in servicing the chiller. The isolation option comes in various configurations depending on the cooler type (flooded or DX) and the installation region (Middle Eastern or elsewhere). On all units equipped with the flooded cooler which are not installed in the Middle East region, a liquid line service valve and a motorized discharge isolation valve are always provided per refrigerant circuit. For Middle Eastern regions only, a manual discharge valve is standard and a motorized discharge ball valve is optional. On units equipped with the optional DX cooler, the liquid line service valve and a manual discharge service valve is included in the isolation valve option, regardless of the region of installation. Regardless of which cooler option is employed, the selection of the isolation valve option results in chillers which are equipped with a liquid line service valve, a discharge service valve (motorized or manual type), and a series of valves on or near the cooler. The net effect is to provide isolation capability in the condenser area, the cooler area and the compressor area.

NOTE: The only situation in which the isolation of the condenser area allows the full charge to be stored in the condenser is when round tube, plate fin (RTPF) coils are employed.

15. Suction Line Insulation:

Unit shall be supplied with suction line insulation. Insulation shall be tubular closed-cell insulation. This option shall be required with applications with leaving fluid temperatures below 30°F (-1.1°C) and recommended for areas of high dewpoints where condensation may be a concern.

16. Service Option:

Unit shall be provided with a service option which provides a remote service port for Navigator™ connection and a factory-installed convenience outlet that includes 4-amp GFI (ground fault interrupt) receptacle with independent fuse protection. Convenience outlet shall be 115-v female receptacle. Service option not available with 380 v.

17. Remote Service Port:

Shall be a field-installed receptacle for Navigator device connection.

18. **Wye-Delta Starter:**
Unit shall have a factory-installed, wye-delta start to minimize electrical inrush current.
19. **Control Transformer:**
Unit shall be supplied with a factory-installed transformer that will allow supply control circuit power from the main unit power supply.
20. **GFI Convenience Outlet:**
Shall be factory or field-installed and mounted with easily accessible 115-v female receptacle. Shall include 4 amp GFI (ground fault interrupt) receptacle. Not available with 380-v units.
21. **Plus-One-Pass Cooler (Flooded Coolers Only):**
Unit shall be equipped with plus-one-pass cooler heads to be used with high delta T application. This option is not available on unit sizes 401-501.
22. **Minus-One-Pass Cooler (Flooded Coolers Only):**
Unit shall be equipped with minus-one-pass cooler heads with reduced water-side pressure drop for series flow dual chiller control or high chilled water flow applications.
23. **High Ambient Temperature:**
Unit shall be equipped with high speed condenser fan motors to improve performance at high ambient temperatures. This option shall be required for 30XA401-501 chillers, and it is also required for all 30XA401-501 chillers which are operating in multi-chiller configurations or have ambient temperatures at or above 100°F (37.8°C).
24. **Security Grilles:**
Unit shall be provided with factory (or field) installed painted grilles to protect the condenser, cooler and compressor.
25. **Upper Hail Guard:**
Unit shall be equipped with a factory-installed option consisting of louvered panels on the ends of the machine which firmly fasten to the machine frame. These panels shall cover the unit from the top to the bottom of the coils, thus providing protection of the coils from hail damage.
26. **Full Hail Guard:**
Unit shall be equipped with field-installed accessory consisting of hinged, louvered panels, which cover both ends of the unit. This accessory provides complete protection from hail.
27. **Full End Screen:**
Unit shall be equipped with a factory-installed option consisting of louvered panels that cover the machine ends from top to bottom and firmly fasten to the machine frame. These end screens function as a privacy screen and also provide hail protection.
28. **Low Sound Package:**
Unit shall be provided with sound attenuation package to include sheet metal enclosures with sound absorbing panels for each compressor.
29. **Remote Cooler Kit:**
Allows remote installation of the cooler. This is not available on sizes 401-501.
30. **Minimum Load Control:**
Unit shall be equipped with microprocessor-controlled minimum load control that shall permit unit operation below the minimum standard operation (varies by unit size).
31. **High SCCR (Short Circuit Current Rating):**
The optional high SCCR (short circuit current rating) device shall allow the chiller to tolerate a 65 kA (460-v units) or 25 kA (575-v units) short circuit current for a brief period of time while protecting downstream components. The high SCCR option shall provide a higher level of protection than the standard unit. This option is only available on 30XA140-352 and only at 460 or 575 volts.
32. **Dual Chiller Accessory Kit:**
For dual chiller applications (with units piped in parallel), unit shall be provided with the additional hardware (thermistors, wells, connectors) required for proper system operation.
33. **Seismic Certification:**
A seismic kit is available which will result in a unit SDS (seismic design acceleration parameter) level of 2.4.

