



Start-Up, Operation and Maintenance Instructions

SAFETY CONSIDERATIONS

Screw liquid chillers are designed to provide safe and reliable service when operated within design specifications. When operating this equipment, use good judgment and safety precautions to avoid damage to equipment and property or injury to personnel.

Be sure you understand and follow the procedures and safety precautions contained in the machine instructions, as well as those listed in this guide.

⚠ DANGER

Failure to follow these procedures will result in severe personal injury or death.

DO NOT VENT refrigerant relief devices within a building. Outlet from rupture disc or relief valve must be vented outdoors in accordance with the latest edition of ANSI/ASHRAE 15 (American National Standards Institute/American Society of Heating, Refrigerating, and Air-Conditioning Engineers). The accumulation of refrigerant in an enclosed space can displace oxygen and cause asphyxiation.

PROVIDE adequate ventilation in accordance with ANSI/ASHRAE 15, especially for enclosed and low overhead spaces. Inhalation of high concentrations of vapor is harmful and may cause heart irregularities, unconsciousness, or death. Intentional misuse can be fatal. Vapor is heavier than air and reduces the amount of oxygen available for breathing. Product causes eye and skin irritation. Decomposition products are hazardous.

DO NOT USE OXYGEN to purge lines or to pressurize a machine for any purpose. Oxygen gas reacts violently with oil, grease, and other common substances.

DO NOT USE air for leak testing. Use only refrigerant or dry nitrogen.

NEVER EXCEED specified test pressures, VERIFY the allowable test pressure by checking the instruction literature and the design pressures on the equipment nameplate.

DO NOT VALVE OFF any safety device.

BE SURE that all pressure relief devices are properly installed and functioning before operating any machine.

RISK OF INJURY OR DEATH by electrocution. High (or medium) voltage is present on motor leads even though the motor is not running. Open the power supply disconnect before touching motor leads or terminals.

⚠ WARNING

Failure to follow these procedures may result in personal injury or death.

DO NOT USE TORCH to remove any component. System contains oil and refrigerant under pressure.

To remove a component, wear protective gloves and goggles and proceed as follows:

- a. Shut off electrical power to unit.
- b. Recover refrigerant to relieve all pressure from system using both high-pressure and low-pressure ports.
- c. Traces of vapor should be displaced with nitrogen and the work area should be well ventilated. Refrigerant in contact with an open flame produces toxic gases.
- d. Cut component connection tubing with tubing cutter, and remove component from unit. Use a pan to catch any oil that may come out of the lines and as a gage for how much oil to add to the system.
- e. Carefully unsweat remaining tubing stubs when necessary. Oil can ignite when exposed to torch flame.

DO NOT USE eyebolts or eyebolt holes to rig heat exchangers or the entire assembly.

DO NOT work on high (or medium) voltage equipment unless you are a qualified electrician.

DO NOT WORK ON electrical components, including control panels, switches, starters, or oil heater until you are sure ALL POWER IS OFF and no residual voltage can leak from capacitors or solid-state components.

LOCK OPEN AND TAG electrical circuits during servicing. IF WORK IS INTERRUPTED, confirm that all circuits are de-energized before resuming work.

AVOID SPILLING liquid refrigerant on skin or getting it into the eyes. USE SAFETY GOGGLES. Wash any spills from the skin with soap and water. If liquid refrigerant enters the eyes, IMMEDIATELY FLUSH EYES with water and consult a physician.

NEVER APPLY an open flame or live steam to a refrigerant cylinder. Dangerous over pressure can result. When it is necessary to heat refrigerant, use only warm (110 F [43 C]) water.

DO NOT REUSE disposable (nonreturnable) cylinders or attempt to refill them. It is DANGEROUS AND ILLEGAL. When cylinder is emptied, evacuate remaining gas pressure, loosen the collar, and unscrew and discard the valve stem. DO NOT INCINERATE.

CHECK THE REFRIGERANT TYPE before adding refrigerant to the machine. The introduction of the wrong refrigerant can cause machine damage or malfunction.

(Warnings continued on next page.)

⚠ WARNING

Operation of this equipment with refrigerants other than those cited herein should comply with ANSI/ASHRAE 15 (latest edition). Contact Carrier for further information on use of this machine with other refrigerants.

DO NOT ATTEMPT TO REMOVE fittings, covers, etc., while machine is under pressure or while machine is running. Be sure pressure is at 0 psig (0 kPa) before breaking any refrigerant connection.

CAREFULLY INSPECT all relief valves, rupture discs, and other relief devices AT LEAST ONCE A YEAR. If machine operates in a corrosive atmosphere, inspect the devices at more frequent intervals.

DO NOT ATTEMPT TO REPAIR OR RECONDITION any relief valve when corrosion or build-up of foreign material (rust, dirt, scale, etc.) is found within the valve body or mechanism. Replace the valve.

DO NOT install relief devices in series or backwards.

USE CARE when working near or in line with a compressed spring. Sudden release of the spring can cause it and objects in its path to act as projectiles.

SOME MODELS MAY EXCEED 85 dBA. Hearing protection should be worn when working in the vicinity of such chillers.

⚠ CAUTION

Failure to follow these procedures may result in personal injury or damage to equipment.

DO NOT STEP on refrigerant lines. Broken lines can whip about and release refrigerant, causing personal injury.

DO NOT climb over a machine. Use platform, catwalk, or staging. Follow safe practices when using ladders.

USE MECHANICAL EQUIPMENT (crane, hoist, etc.) to lift or move inspection covers or other heavy components. Even if components are light, use mechanical equipment when there is a risk of slipping or losing your balance.

BE AWARE that certain automatic start arrangements CAN ENGAGE THE STARTER, TOWER FAN, OR PUMPS. Open the disconnect ahead of the starter, tower fan, and pumps. Shut off the machine or pump before servicing equipment.

USE only repaired or replacement parts that meet the code requirements of the original equipment.

DO NOT VENT OR DRAIN waterboxes containing industrial brines, liquid, gases, or semisolids without the permission of your process control group.

DO NOT LOOSEN waterbox cover bolts until the water-box has been completely drained.

DOUBLE-CHECK that coupling nut wrenches, dial indicators, or other items have been removed before rotating any shafts.

DO NOT LOOSEN a packing gland nut before checking that the nut has a positive thread engagement.

PERIODICALLY INSPECT all valves, fittings, and piping for corrosion, rust, leaks, or damage.

PROVIDE A DRAIN connection in the vent line near each pressure relief device to prevent a build-up of condensate or rain water.

DO NOT re-use compressor oil or any oil that has been exposed to the atmosphere. Dispose of oil per local codes and regulations.

⚠ CAUTION

DO NOT leave refrigerant system open to air any longer than the actual time required to service the equipment. Seal circuits being serviced and charge with dry nitrogen to prevent oil contamination when timely repairs cannot be completed.

⚠ CAUTION

Chiller must be installed in an indoor environment where the ambient temperature is between 40 to 104 F (4 to 40 C) with a relative humidity (non-condensing) of 95% or less. To ensure that electrical components operate properly and to avoid equipment damage, do not locate chiller in an area exposed to dust, dirt, corrosive fumes, or excessive heat and humidity.

CONTENTS

	Page
SAFETY CONSIDERATIONS	1,2
INTRODUCTION	5
ABBREVIATIONS AND EXPLANATIONS	5
23XRV CHILLER FAMILIARIZATION	5-13
Chiller Identification Nameplate	5
System Components	5
Cooler	12
Condenser	12
Motor-Compressor	12
Muffler	12
Control Center	12
Storage Vessel (Optional)	12
REFRIGERATION CYCLE	13-15
MOTOR COOLING CYCLE	16
LUBRICATION CYCLE	16-18
Summary	16
Details	16
Oil Reclaim System	17
Capacity Control	18
CONTROLS	18-60
Definitions	18
• ANALOG SIGNAL	
• DISCRETE SIGNAL	
General Controls Overview	18
PIC III System Components	18
• INTERNATIONAL CHILLER VISUAL CONTROLLER (ICVC)	
• CHILLER CONTROL MODULE (CCM)	
• VFD POWER MODULE	
• VFD GATEWAY MODULE	
• OIL HEATER CONTACTOR (1C)	
• OIL PUMP CONTACTOR (2C)	
• HOT GAS BYPASS CONTACTOR RELAY (3C) (Optional)	
• SECOND STAGE OIL HEATER CONTACTOR(5C)	
• VAPORIZER HEATER CONTACTOR (6C)	
• CONTROL TRANSFORMERS (T1, T2, T4)	
• EXV CONTROL MODULE (PD4-EXV)	
• AUXILIARY CONTROL MODULE (PD4-AUX1)	
• ELECTRONIC EXPANSION VALVE	
• CONDENSER LEVEL SENSOR	

CONTENTS (cont)

	Page		Page
ICVC Operation and Menus	23	Local Start-Up	60
• GENERAL		Shutdown Sequence	61
• ALARMS AND ALERTS		Automatic Soft Stop Amps Threshold	61
• ICVC MENU ITEMS		Chilled Liquid Recycle Mode	62
• BASIC ICVC OPERATIONS (Using the Softkeys)		Safety Shutdown	62
• TO VIEW STATUS		BEFORE INITIAL START-UP	62-81
• OVERRIDE OPERATIONS		Job Data Required	62
• TIME SCHEDULE OPERATION		Equipment Required	62
• TO VIEW AND CHANGE SET POINTS		Using the Optional Storage Tank and Pumpout System	62
• SERVICE OPERATION		Remove Shipping Packaging	62
PIC III System Functions	46	Open Oil Circuit Valves	62
• CAPACITY CONTROL		Oil Charge	62
• FORCED		Tighten All Gasketed Joints	63
• NORMAL CONDITIONS		Check Chiller Tightness	64
• CAPACITY INCREASE		Refrigerant Tracer	64
• CAPACITY DECREASE		Leak Test Chiller	64
• ECL CONTROL OPTION		Chiller Dehydration	71
• CHILLED LIQUID DEADBAND		Inspect Liquid Piping	71
• PROPORTIONAL BANDS AND PROPORTIONAL GAIN		Inspect Refrigerant Cooling Lines	71
• DEMAND LIMITING		Check Optional Pumpout Compressor Liquid Piping	72
• CHILLER TIMERS		Check Relief Valves	72
• OCCUPANCY SCHEDULE		Identify the VFD	72
Safety Controls	47	• IDENTIFYING THE DRIVE BY PART NUMBER	
Shunt Trip	48	Check Control Center	73
Default Screen Freeze	48	Input Power Wiring	73
Ramp Loading	48	Checking the Installation	73
Capacity Override	48	Inspect Wiring	74
Compressor Minimum Speed Override	48	Ground Fault Troubleshooting	74
Vaporizer Temperature Control		Carrier Comfort Network® Interface	75
COMPRESSOR ON	48	Power Up the Controls and Check the Oil Heater	75
Oil Sump Temperature Control		Software Configuration	75
COMPRESSOR OFF	48	Input the Design Set Points	75
Oil Sump Temperature Control		Input the Local Occupancy Schedule (OCCPC01S)	75
COMPRESSOR ON	52	Input Service Configurations	75
Remote Start/Stop Contacts	52	• PASSWORD	
Spare Safety and Spare Temperature Inputs	52	• INPUT TIME AND DATE	
Spare Alarm Contacts	52	• CHANGE ICVC CONFIGURATION IF NECESSARY	
Refrigerant Leak Detector	52	• TO CHANGE THE PASSWORD	
4 to 20 mA Kilowatt Output	52	• TO CHANGE THE ICVC DISPLAY FROM ENGLISH TO METRIC UNITS	
Remote Reset of Alarms	52	• MODIFY CONTROLLER IDENTIFICATION IF NECESSARY	
Condenser Pump Control	53	• INPUT EQUIPMENT SERVICE PARAMETERS IF NECESSARY	
Condenser Freeze Prevention	53	• MODIFY EQUIPMENT CONFIGURATION IF NECESSARY	
Tower Fan Relay Low and High	53	Perform a Control Test	78
Auto. Restart After Power Failure	53	Pressure Transducer and Optional Flow Device Calibration	78
Fast Power Source Transfers	53	• ZERO POINT CALIBRATION	
Liquid/Brine Temperature Reset	53	• HIGH END CALIBRATION	
• RESET TYPE 1		Check Optional Pumpout System Controls and Compressor	79
• RESET TYPE 2		High Altitude Locations	79
• RESET TYPE 3		Charge Refrigerant Into Chiller	79
Demand Limit Control Option	54	• CHILLER EQUALIZATION WITHOUT A PUMPOUT UNIT	
Hot Gas Bypass (Optional) Algorithm	54	• CHILLER EQUALIZATION WITH PUMPOUT UNIT	
Head Pressure Output Reference	54	• CHILLER SHIPPED WITH HOLDING CHARGE	
Lead/Lag Control	56	• TRIMMING REFRIGERANT CHARGE	
• COMMON POINT SENSOR INSTALLATION		INITIAL START-UP	82,83
• CHILLER COMMUNICATION WIRING		Preparation	82
• LEAD/LAG OPERATION		Check Oil Pressure and Compressor Stop	82
• FAULTED CHILLER OPERATION		To Prevent Accidental Start-Up	82
• LOAD BALANCING			
• AUTO. RESTART AFTER POWER FAILURE			
Attach to Network Device Control	58		
• ATTACHING TO OTHER CCN MODULES			
Service Operation	59		
• TO ACCESS THE SERVICE SCREENS			
• TO LOG OUT OF DEVICE			
• HOLIDAY SCHEDULING			
START-UP/SHUTDOWN/RECYCLE SEQUENCE	60-62		

CONTENTS (cont)

	Page
Check Chiller Operating Condition	82
Instruct the Customer Operator	82
• COOLER-CONDENSER	
• OPTIONAL PUMPOUT STORAGE TANK AND PUMPOUT SYSTEM	
• COMPRESSOR ASSEMBLY	
• COMPRESSOR LUBRICATION SYSTEM	
• CONTROL SYSTEM	
• AUXILIARY EQUIPMENT	
• DESCRIBE CHILLER CYCLES	
• REVIEW MAINTENANCE	
• SAFETY DEVICES AND PROCEDURES	
• CHECK OPERATOR KNOWLEDGE	
• REVIEW THE START-UP, OPERATION AND MAINTENANCE MANUAL	
OPERATING INSTRUCTIONS	83-85
Operator Duties	83
Prepare the Chiller for Start-Up	83
To Start The Chiller	83
Check the Running System	83
To Stop the Chiller	83
• FAILURE TO STOP	
After Limited Shutdown	84
Preparation for Extended Shutdown	84
After Extended Shutdown	84
Cold Weather Operation	84
Refrigeration Log	84
PUMPOUT AND REFRIGERANT TRANSFER PROCEDURES	86-93
Preparation	86
Operating the Optional Pumpout Unit	86
Chillers with Storage Tanks	87
• UNITS WITH Q AND R COMPRESSORS ONLY	
• UNITS WITH P COMPRESSORS ONLY	
GENERAL MAINTENANCE	93, 94
Refrigerant Properties	93
Adding Refrigerant	93
Removing Refrigerant	93
Adjusting the Refrigerant Charge	93
Refrigerant Leak Testing	93
Refrigerant Leak Rate	93
Test After Service, Repair, or Major Leak	94
• REFRIGERANT TRACER	
• TO PRESSURIZE WITH DRY NITROGEN	
Repair the Refrigerant Leak, Retest, and Apply Standing Vacuum Test	94
Trim Refrigerant Charge	94
WEEKLY MAINTENANCE	94
Check the Lubrication System	94
SCHEDULED MAINTENANCE	94-100
Service Overtime	94
Inspect the Control Center	94
Check Safety and Operating Controls	
Monthly	94
Changing Oil and Oil Filter	94
• CHANGING OIL	
Oil Specification	95
Oil Heater	95
Refrigerant Filter/Drier	95
Oil Strainers	95
VFD Refrigerant Strainer	96
Vaporizer Refrigerant Return Line Orifice	96
Compressor Inlet Bearing Oil Orifice	96
Inspect Condenser Refrigerant Float System	96
Inspect Variable Frequency Drive	98
Inspect Relief Valves and Piping	98
Compressor Bearing Maintenance	98
Compressor Rotor Check	98
Motor Insulation	98
Inspect the Heat Exchanger Tubes	99
• COOLER	
• CONDENSER	
Water/Brine Leaks	99
Water/Brine Treatment	99
Inspect the Control Center	99
Recalibrate Pressure Transducers	99
Optional Pumpout System Maintenance	99
• OPTIONAL PUMPOUT COMPRESSOR OIL CHARGE	
• OPTIONAL PUMPOUT SAFETY CONTROL SETTINGS	
Ordering Replacement Chiller Parts	100
TROUBLESHOOTING GUIDE	100-148
Overview	100
Checking Display Messages	101
Checking Temperature Sensors	101
• RESISTANCE CHECK	
• VOLTAGE DROP	
• CHECK SENSOR ACCURACY	
• DUAL MOTOR TEMPERATURE SENSORS	
Checking Pressure Transducers	101
• COOLER CONDENSER PRESSURE TRANSDUCER AND OPTIONAL WATER SIDE PRESSURE TRANSDUCER CALIBRATION	
• TRANSDUCER REPLACEMENT	
Control Algorithms Checkout Procedure	102
Control Test	102
Control Modules	123
• RED LED (Labeled as STAT)	
• GREEN LED (Labeled as COM)	
Notes on Module Operation	123
Chiller Control Module (CCM)	123
Replacing Defective ICVC Modules	124
• INSTALLATION	
Gateway Status LEDs	125
• DRIVE STATUS INDICATOR	
• MS STATUS INDICATOR	
• NET A STATUS INDICATOR	
• NET B STATUS INDICATOR	
• PD4 EXV BOARD (P Compressor Only)	
• PD4 AUX1 BOARD (P Compressor Only)	
• EXV TROUBLESHOOTING	
End of Life and Equipment Disposal	129
Physical Data	129
APPENDIX A — ICVC PARAMETER INDEX	149-156
APPENDIX B — MAINTENANCE SUMMARY AND LOG SHEETS	157-160
APPENDIX C — BACNET COMMUNICATION OPTION	161-167
INDEX	168
INITIAL START-UP CHECKLIST FOR 23XRV VARIABLE SPEED SCREW CHILLER WITH GREENSPEED INTELLIGENCE	CL-1 to CL-10

INTRODUCTION

⚠ CAUTION

This unit uses a microprocessor control system. Do not short or jumper between terminations on circuit boards or modules; control or board failure may result.

Be aware of electrostatic discharge (static electricity) when handling or making contact with circuit boards or module connections. Always touch a chassis (grounded) part to dissipate body electrostatic charge before working inside control center.

Use extreme care when handling tools near boards and when connecting or disconnecting terminal plugs. Circuit boards can easily be damaged. Always hold boards by the edges and avoid touching components and connections.

This equipment uses, and can radiate, radio frequency energy. If not installed and used in accordance with the instruction manual, it may cause interference to radio communications. The chiller control boards have been tested and found to comply with the limits for a Class A computing device pursuant to International Standard in North America EN 61000-2/3 which are designed to provide reasonable protection against such interference when operated in a commercial environment. Operation of this equipment in a residential area is likely to cause interference, in which case the user, at his own expense, will be required to take whatever measures may be required to correct the interference.

Always store and transport replacement or defective boards in anti-static shipping bag.

Prior to initial start-up of the 23XRV chiller, those involved in the start-up, operation, and maintenance should be thoroughly familiar with these instructions and other necessary job data. This book is outlined to familiarize those involved in the start-up, operation and maintenance of the unit with the control system before performing start-up procedures. Procedures in this manual are arranged in the sequence required for proper chiller start-up and operation.

ABBREVIATIONS AND EXPLANATIONS

Frequently used abbreviations in this manual include:

CCM	— Chiller Control Module
CCN	— Carrier Comfort Network®
CCW	— Counterclockwise
CSM	— Chillervisor System Manager
CW	— Clockwise
DPI	— LF2 VFD Drive Peripheral Interface Board
ECDL	— Entering Condenser Liquid
ECL	— Entering Chilled Liquid
EMS	— Energy Management System
EXV	— Electronic Expansion Valve
HGBP	— Hot Gas Bypass
ICVC	— International Chiller Visual Controller
IGBT	— Insulated Gate Bipolar Transistor
I/O	— Input/Output
KAIC	— Kiloamps Interrupt Capacity
LCD	— Liquid Crystal Display
LCDL	— Leaving Condenser Liquid
LCL	— Leaving Chilled Liquid
LED	— Light-Emitting Diode
LEI	— Local Equipment Interface Translator
LF2	— Reliance LiquiFlo™ 2 VFD with Active Rectifier
OIM	— Reliance Operator Interface Module
OLTA	— Overload Trip Amps
PIC III	— Product Integrated Control III
RLA	— Rated Load Amps
RS485	— Communications Type used by ICVC and CCM
SCR	— Silicon Controlled Rectifier
SI	— International System of Units
SIO	— Sensor Input/Output
TB1	— Control Center Terminal Block 1
TB2	— Control Center Terminal Block 2
VFD	— Variable Frequency Drive
VFG	— Variable Frequency Gateway Module

Words printed in all capital letters or in italics may be viewed on the International Chiller Visual Controller (ICVC) (e.g., LOCAL, CCN, ALARM, etc.).

Words printed in both all capital letters and italics can also be viewed on the ICVC and are parameters (e.g., *CONTROL MODE*, *COMPRESSOR START RELAY*, etc.) with associated values (e.g., modes, temperatures, percentages, pressures, on, off, etc.).

Words printed in all capital letters and in a box represent softkeys on the ICVC control center (e.g., **ENTER**, **EXIT**, **INCREASE**, **QUIT**, etc.).

Factory-installed additional components are referred to as options in this manual; factory-supplied but field-installed additional components are referred to as accessories.

The chiller software part number of the 23XRV unit is located on the back of the ICVC.

23XRV CHILLER FAMILIARIZATION (FIG. 1-7)

Chiller Identification Nameplate — The chiller identification nameplate is located on the right side of the chiller control center.

System Components — The components include cooler and condenser, heat exchangers in separate vessels, motor-compressor, lubrication system, control center, and optional economizer.

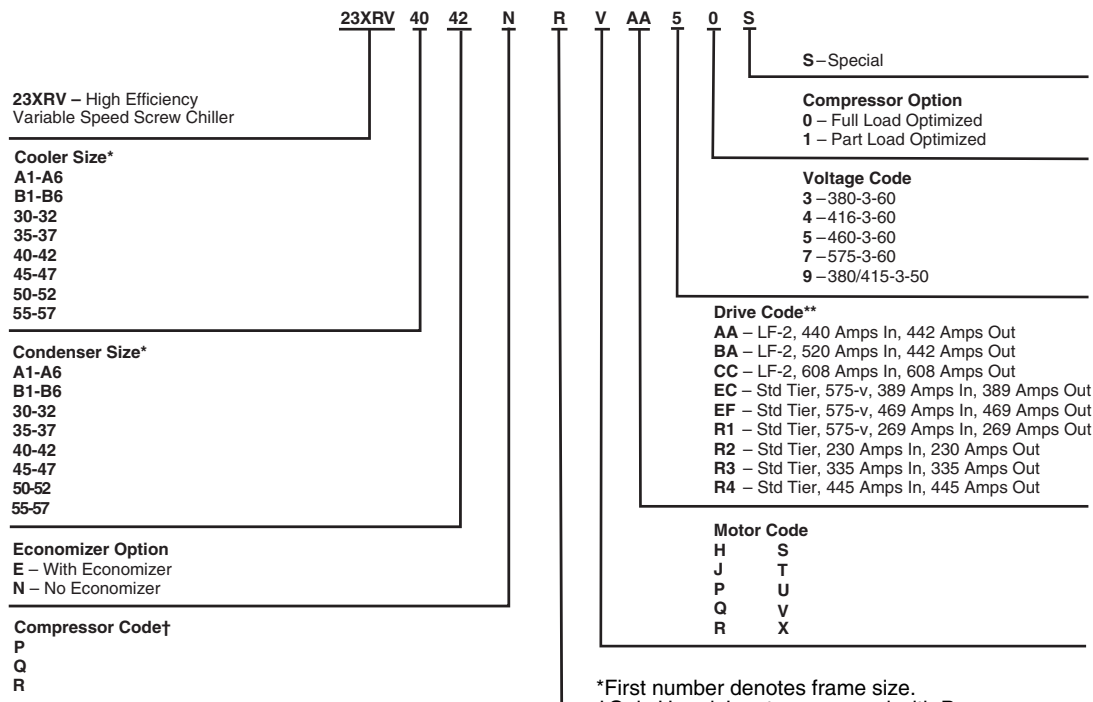

*First number denotes frame size.
†Only H and J motors are used with P compressors. Only type V motors are used with Q compressors.
**Maximum limits only. Additional application limits apply that may reduce these ampacities.

Fig. 1 — Model Number Identification

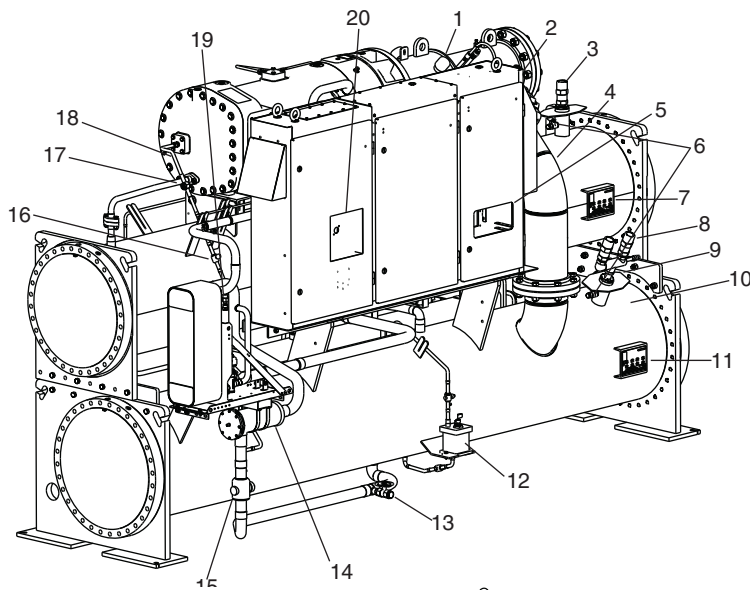

- 1 — Discharge Pipe
- 2 — Variable Frequency Drive
- 3 — Cooler Relief Valve
- 4 — Compressor Discharge Pipe
- 5 — International Chiller Visual Controller (ICVC)
- 6 — Refrigerant Charging Valve
- 7 — ASME Nameplate, Evaporator
- 8 — Condenser Relief Valves
- 9 — Tubesheet Mounting Brackets
- 10 — Condenser
- 11 — ASME Nameplate, Condenser
- 12 — Level Sensing Chamber
- 13 — Condenser Refrigerant Pumpout Valve
- 14 — Refrigerant Strainer
- 15 — Cooler Inlet Isolation Valve
- 16 — Motor Cooling Isolation Valve
- 17 — Motor Cooling Sight Glass
- 18 — Motor Cooling Supply Line
- 19 — Motor Cooling Line Filter Drier (Hidden)
- 20 — VFD Disconnect

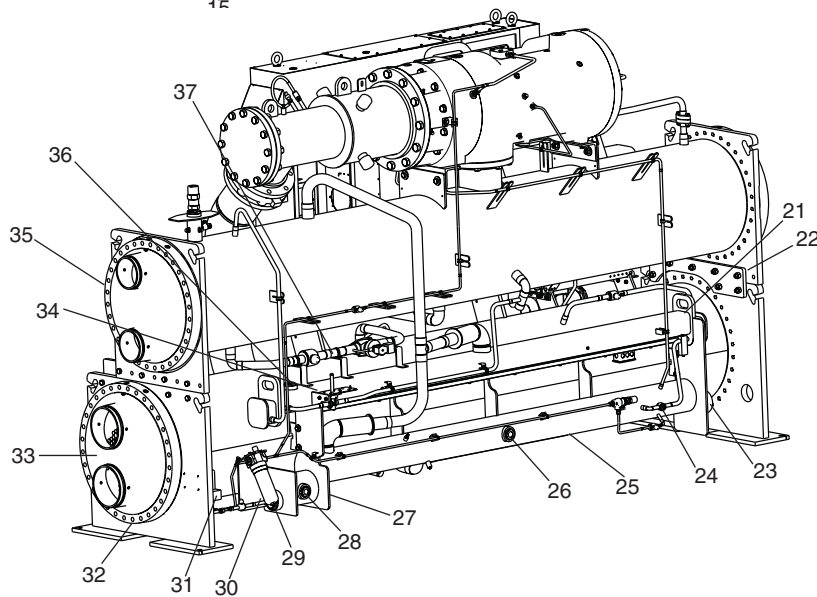

- 21 — Vaporizer
- 22 — Tubesheet Mounting Brackets
- 23 — Oil Sump Heater (Hidden)
- 24 — Vaporizer Drain Sight Glass
- 25 — Oil Sump
- 26 — Oil Sump Sight Glass
- 27 — Oil Charging Drain Valve (Hidden)
- 28 — Strainer Housing Sight Glass
- 29 — Oil Pump Inlet Strainer
- 30 — Oil Filter Assembly
- 31 — Oil Pump
- 32 — Typical Waterbox Drain Coupling (Hidden)
- 33 — Condenser Supply/Return End Waterbox
- 34 — Oil Reclaim Actuator
- 35 — Cooler Supply/Return End Waterbox
- 36 — Vaporizer Sight Glass
- 37 — Hot Gas Bypass Line (Option)

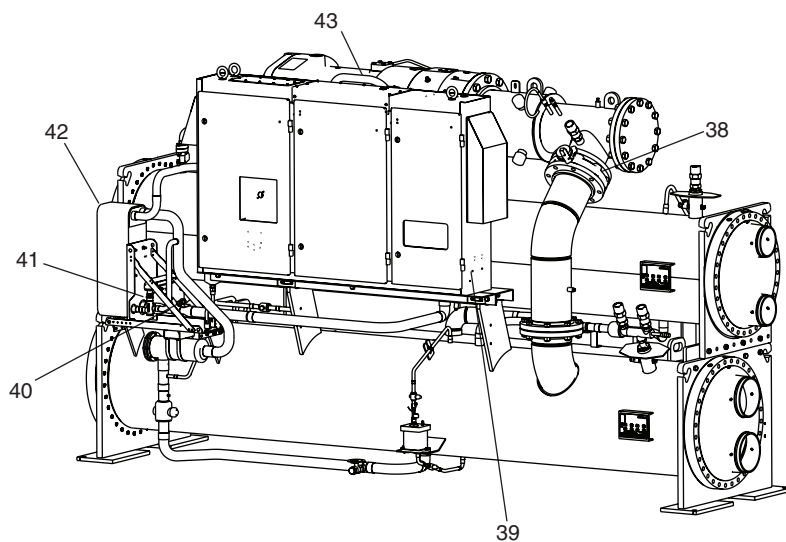

- 38 — Discharge Isolation Valve Assembly (Option or Accessory)
- 39 — Machine Electrical Data Nameplate
- 40 — Main EXV
- 41 — Economizer Gas EXV (Option)
- 42 — Economizer (Option)
- 43 — Economizer Muffler (Hidden)

Fig. 2 — Typical 23XRV Components (Units with P Compressor)

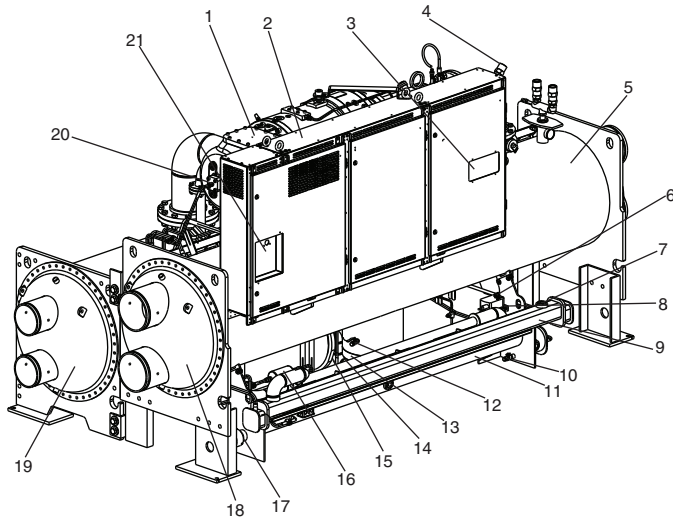

- 1 — Motor Terminal Cover Plate
- 2 — Variable Frequency Drive
- 3 — International Chiller Visual Controller (ICVC)
- 4 — Discharge Pipe Relief Valve
- 5 — Condenser
- 6 — Oil Reclaim Actuator
- 7 — Vaporizer Sight Glass
- 8 — Oil Filter Assembly (Hidden)
- 9 — Vaporizer
- 10 — Oil Charging/Drain Valve
- 11 — Oil Sump
- 12 — Condenser Refrigerant Pumpout Valve
- 13 — Condenser Float Chamber
- 14 — Cooler Inlet Isolation Valve
- 15 — ASME Nameplate, Economizer (Hidden)
- 16 — Filter Drier
- 17 — Oil Sump Heater
- 18 — Condenser Supply/Return End Waterbox
- 19 — Cooler Supply/Return End Waterbox
- 20 — Motor Cooling Supply Line
- 21 — VFD Disconnect

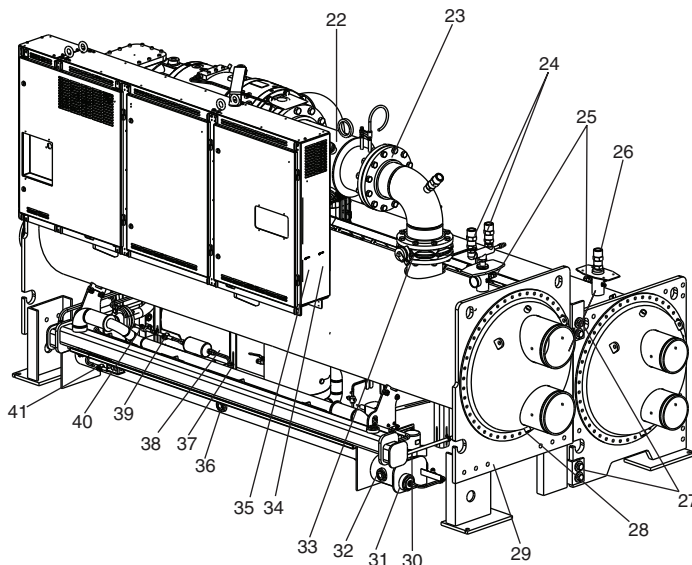

- 22 — Discharge Pipe
- 23 — Compressor Discharge Check Valve Access Cover
- 24 — Condenser Relief Valves
- 25 — Refrigerant Charging Valves
- 26 — Cooler Relief Valve
- 27 — Tubesheet Mounting Brackets
- 28 — Typical Waterbox Drain Coupling
- 29 — ASME Nameplate, Condenser
- 30 — Oil Pump
- 31 — Oil Pump Inlet Strainer
- 32 — Strainer Housing Sight Glass
- 33 — Discharge Isolation Valve (Option or Accessory)
- 34 — Refrigeration Machine Nameplate
- 35 — Machine Electrical Data Nameplate
- 36 — Oil Sump Sight Glass
- 37 — Filter Drier Isolation Valve with Schrader Valve
- 38 — Economizer
- 39 — Motor Cooling Sight Glass
- 40 — Motor Cooling Isolation Valve
- 41 — Vaporizer Drain Sight Glass

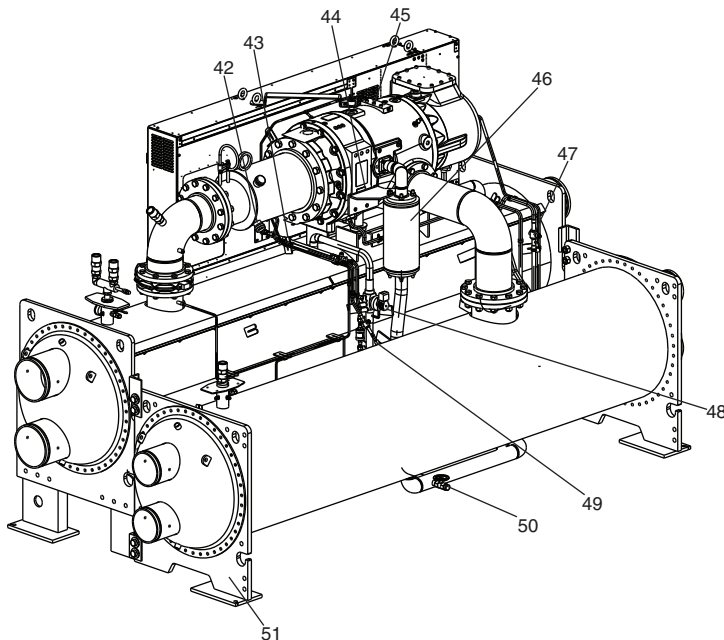

- 42 — VFD Cold Plate Refrigeration Inlet Connection (Outlet Hidden)
- 43 — VFD Cold Plate Solenoid
- 44 — Compressor Nameplate
- 45 — Compressor Lubrication Block
- 46 — Economizer Muffler
- 47 — Vaporizer Condenser Gas Isolation Valve
- 48 — Hot Gas Bypass Isolation and Trim Valve
- 49 — VFD Cooling Refrigerant Strainer
- 50 — Cooler Refrigerant Pumpout Valve
- 51 — ASME Nameplate, Cooler

Fig. 3 — Typical 23XRV Components (Units with Q Compressor)

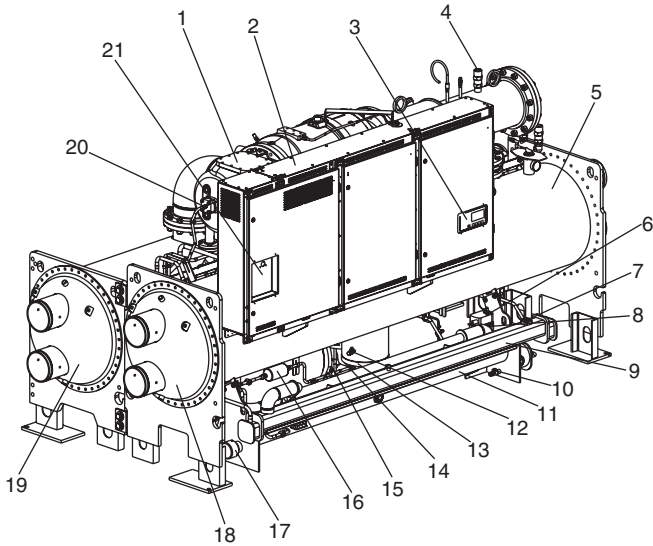

- 1 — Motor Terminal Cover Plate
- 2 — Variable Frequency Drive
- 3 — International Chiller Visual Controller (ICVC)
- 4 — Discharge Pipe Relief Valve
- 5 — Condenser
- 6 — Oil Reclaim Actuator
- 7 — Vaporizer Sight Glass
- 8 — Oil Filter Assembly (Hidden)
- 9 — Vaporizer
- 10 — Oil Charging/Drain Valve
- 11 — Oil Sump
- 12 — Condenser Refrigerant Pumpout Valve
- 13 — Condenser Float Chamber
- 14 — Cooler Inlet Isolation Valve
- 15 — ASME Nameplate, Economizer (Hidden)
- 16 — Filter Drier
- 17 — Oil Sump Heater
- 18 — Condenser Supply/Return End Waterbox
- 19 — Cooler Supply/Return End Waterbox
- 20 — Motor Cooling Supply Line
- 21 — VFD Disconnect

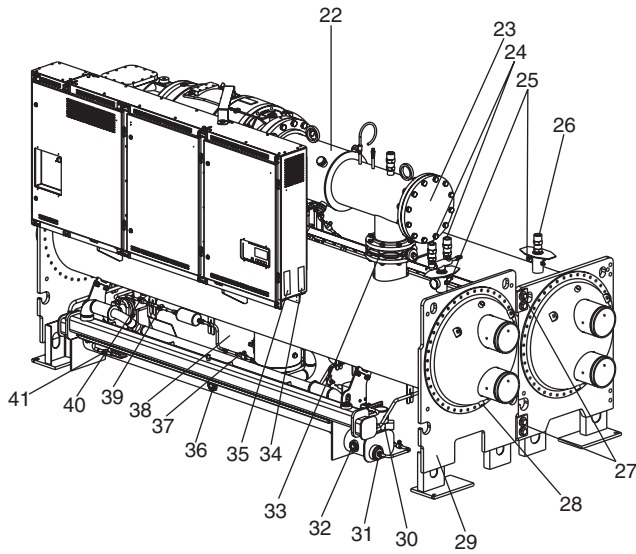

- 22 — Discharge Pipe
- 23 — Compressor Discharge Check Valve Access Cover
- 24 — Condenser Relief Valves
- 25 — Refrigerant Charging Valves
- 26 — Cooler Relief Valve
- 27 — Tubesheet Mounting Brackets
- 28 — Typical Waterbox Drain Coupling
- 29 — ASME Nameplate, Condenser
- 30 — Oil Pump
- 31 — Oil Pump Inlet Strainer
- 32 — Strainer Housing Sight Glass
- 33 — Discharge Isolation Valve (Option or Accessory)
- 34 — Refrigeration Machine Nameplate
- 35 — Machine Electrical Data Nameplate
- 36 — Oil Sump Sight Glass
- 37 — Filter Drier Isolation Valve with Schrader Valve
- 38 — Economizer
- 39 — Motor Cooling Sight Glass
- 40 — Motor Cooling Isolation Valve
- 41 — Vaporizer Drain Sight Glass

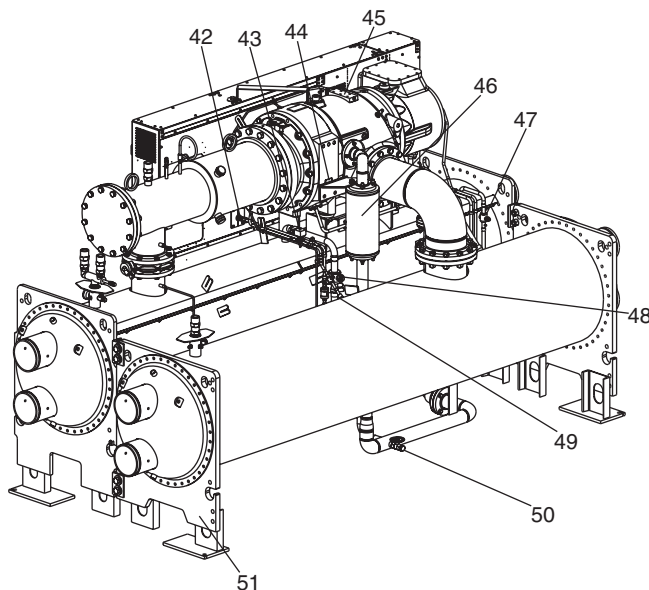

- 42 — VFD Cold Plate Refrigeration Inlet Connection (Outlet Hidden)
- 43 — VFD Cold Plate Solenoid
- 44 — Compressor Nameplate
- 45 — Compressor Lubrication Block
- 46 — Economizer Muffler
- 47 — Vaporizer Condenser Gas Isolation Valve
- 48 — Hot Gas Bypass Isolation and Trim Valve
- 49 — VFD Cooling Refrigerant Strainer
- 50 — Cooler Refrigerant Pumpout Valve
- 51 — ASME Nameplate, Cooler

Fig. 4 — Typical 23XRV Components (Units with R Compressor)

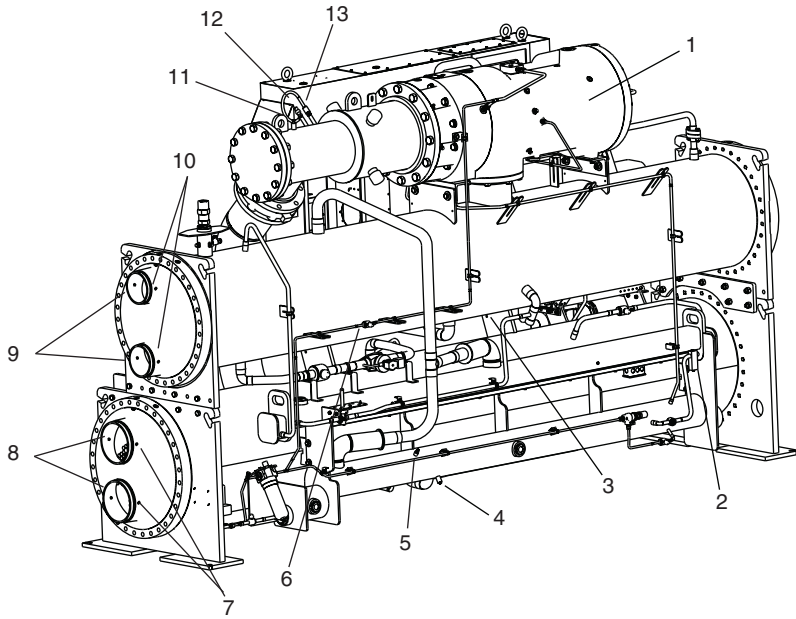

- 1 — Compressor Motor Winding Temperature (Hidden)
- 2 — Vaporizer Temperature
- 3 — Evaporator Liquid Temperature
- 4 — Oil Sump Temperature
- 5 — Oil Sump Pressure
- 6 — Supply Oil Pressure
- 7 — Condenser Liquid Temperature (Hidden)
- 8 — Condenser Liquid Flow (Optional)
- 9 — Evaporator Liquid Flow (Optional)
- 10 — Evaporator Liquid Temperature (Hidden)
- 11 — Compressor Discharge Temperature
- 12 — Compressor Discharge Pressure
- 13 — Compressor Discharge High Pressure Switch

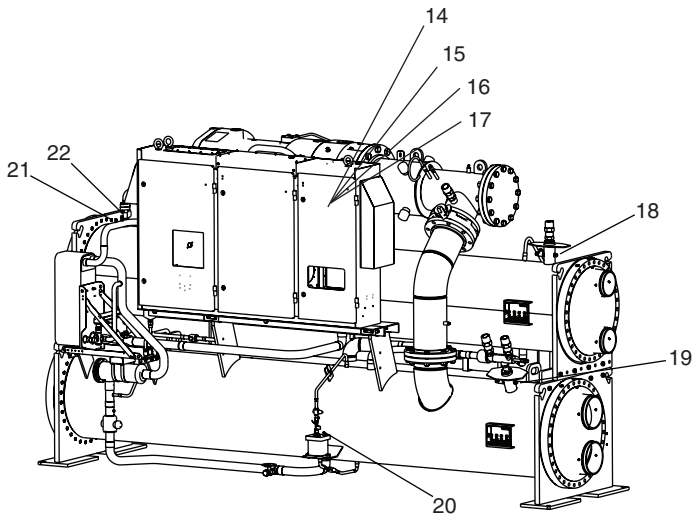

- 14 — Inductor Temperature Switch (Inside VFD Enclosure)
- 15 — VFD Rectifier Temperature (Inside Power Module)
- 16 — VFD Heat Sink Temperature (Inside VFD Enclosure)
- 17 — VFD Inverter Temperature (Inside Power Module)
- 18 — Evaporator Pressure
- 19 — Condenser Pressure
- 20 — Condenser Liquid Level Sensor
- 21 — Economizer Pressure (Optional)
- 22 — Economizer Temperature (Optional)

Fig. 5 — Typical 23XRV Installation — Sensor Locations (Units with P Compressor)

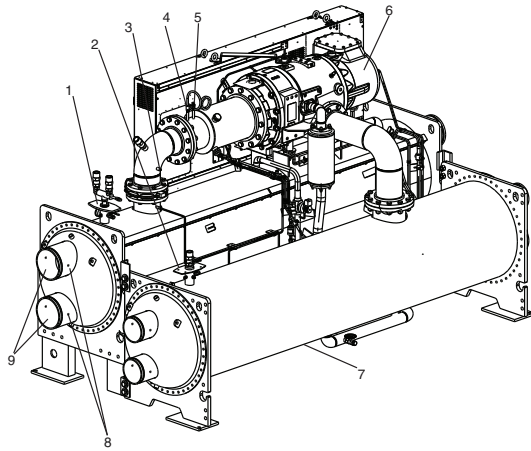

- 1 — Condenser Pressure
- 2 — Evaporator Pressure
- 3 — Compressor Discharge Temperature
- 4 — Compressor Discharge Pressure
- 5 — Compressor Discharge High Pressure Switch
- 6 — Compressor Motor Winding Temperature (Hidden)
- 7 — Evaporator Refrigerant Liquid Temperature (Hidden)
- 8 — Condenser Liquid Temperature
- 9 — Condenser Liquid Flow (Optional)

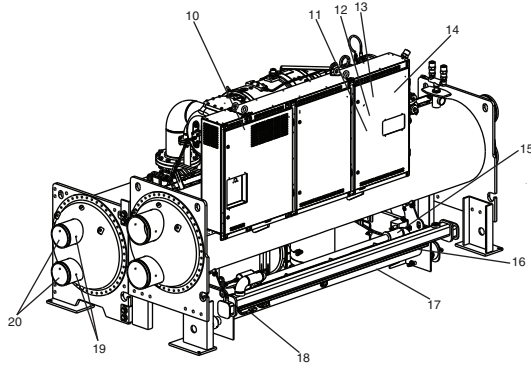

- 10 — Inductor Temperature Switch (Inside VFD Enclosure)
- 11 — VFD Rectifier Temperature (Inside Power Module)
- 12 — VFD Cold Plate Temperature (Inside VFD Enclosure)
- 13 — VFD Inverter Temperature (Inside Power Module)
- 14 — Humidity Sensor (Inside VFD Enclosure)
- 15 — Oil Pressure Leaving Filter (Hidden)
- 16 — Oil Sump Pressure (Hidden)
- 17 — Oil Sump Temperature (Hidden)
- 18 — Vaporizer Temperature
- 19 — Evaporator Liquid Temperature
- 20 — Evaporator Liquid Flow (Optional)

Fig. 6 — Typical 23XRV Installation — Sensor Locations (Units with Q Compressor)

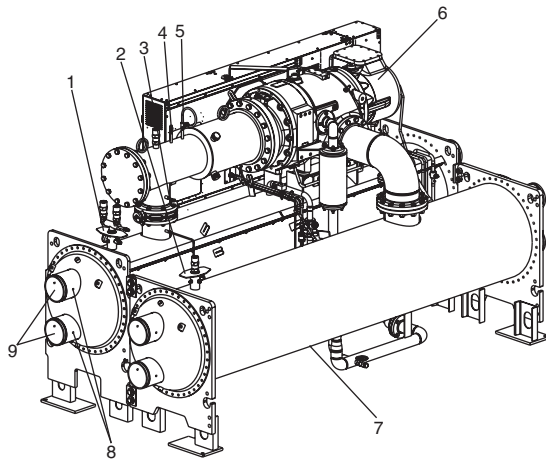

- 1 — Condenser Pressure
- 2 — Evaporator Pressure
- 3 — Compressor Discharge Temperature
- 4 — Compressor Discharge Pressure
- 5 — Compressor Discharge High Pressure Switch
- 6 — Compressor Motor Winding Temperature (Hidden)
- 7 — Evaporator Refrigerant Liquid Temperature (Hidden)
- 8 — Condenser Liquid Temperature
- 9 — Condenser Liquid Flow (Optional)

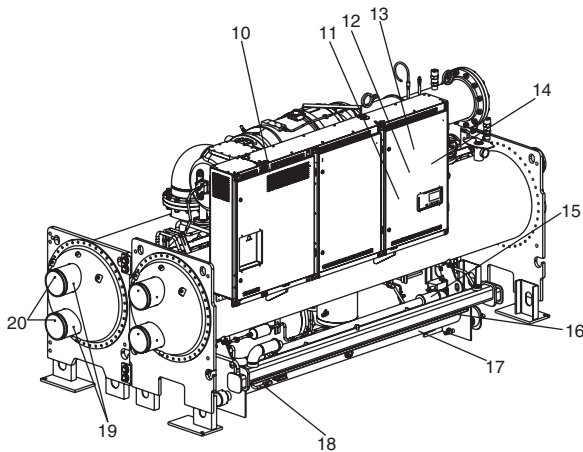

- 10 — Inductor Temperature Switch (Inside VFD Enclosure)
- 11 — VFD Rectifier Temperature (Inside Power Module)
- 12 — VFD Cold Plate Temperature (Inside VFD Enclosure)
- 13 — VFD Inverter Temperature (Inside Power Module)
- 14 — Humidity Sensor (Inside VFD Enclosure)
- 15 — Oil Pressure Leaving Filter (Hidden)
- 16 — Oil Sump Pressure (Hidden)
- 17 — Oil Sump Temperature (Hidden)
- 18 — Vaporizer Temperature
- 19 — Evaporator Liquid Temperature
- 20 — Evaporator Liquid Flow (Optional)

Fig. 7 — Typical 23XRV Installation — Sensor Locations (Units with R Compressor)

Cooler — The cooler (also known as the evaporator) is maintained at low temperature/pressure so that evaporating refrigerant can remove heat from the liquid flowing through its internal tubes.

Condenser — This vessel is located underneath the compressor. The condenser operates at a higher temperature/pressure than the cooler and has liquid flowing through its internal tubes to remove heat from the refrigerant.

Motor-Compressor — The motor-compressor maintains system temperature/pressure differences and moves the heat carrying refrigerant from the cooler to the condenser. See Fig. 8.

Muffler — The muffler provides acoustical attenuation. A check valve just downstream of the muffler prevents reverse compressor rotation during shutdown.

Control Center — The control center is the user interface for controlling the chiller and regulating the chiller's capacity to maintain the proper chilled liquid temperature. See Fig. 9. The control center:

- registers cooler, condenser, and lubricating system pressures
- shows chiller operating condition and alarm shutdown conditions

- records the total chiller operating hours, starts, and the number of hours the chiller has been currently running
- sequences chiller start, stop, and recycle under microprocessor control
- provides access to other Carrier Comfort Network® devices
- provides machine protection

Storage Vessel (Optional) — Two sizes of storage vessels are available. The vessels have double relief valves, a magnetically coupled dial-type refrigerant level gage, a 1-in. FPT drain valve, and a 1/2-in. male flare vapor connection for the pumpout unit. A 30-in.-0-400 psi (-101-0-2750 kPa) gage is also supplied with each unit.

NOTE: If a storage vessel is not used at the jobsite, factory-installed optional isolation valves may be used to isolate the chiller charge in either the cooler or condenser. An optional pumpout compressor system is used to transfer refrigerant from vessel to vessel.

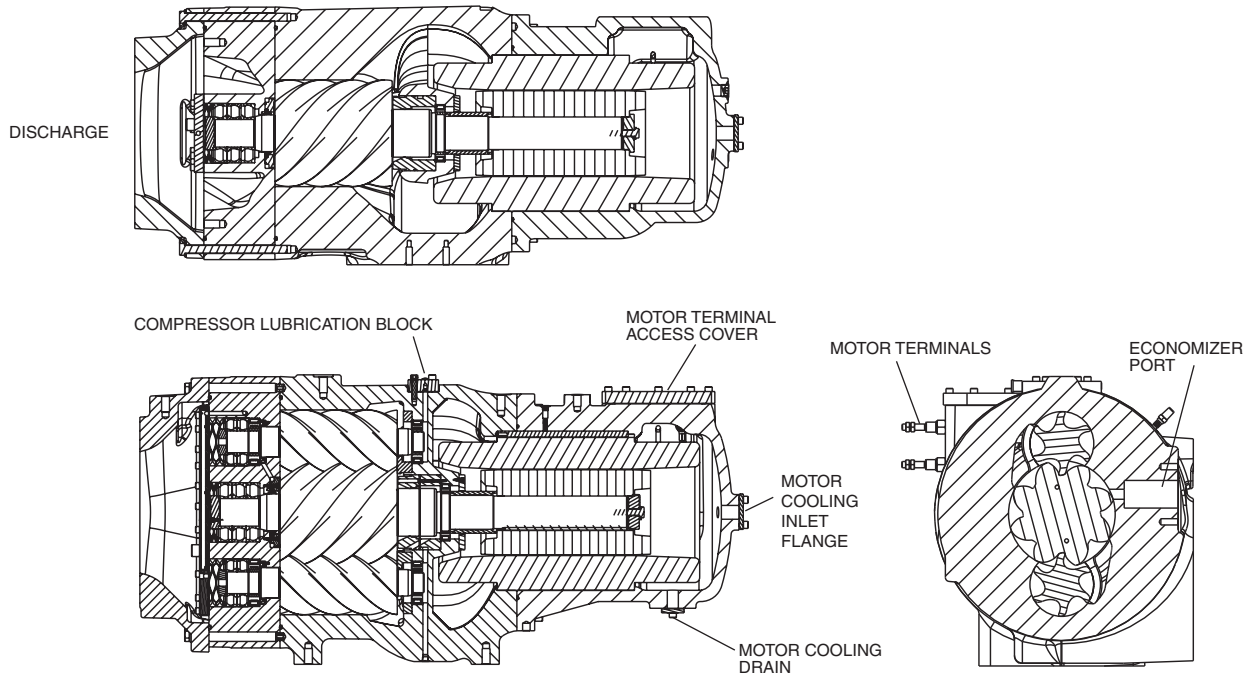

Fig. 8 — Compressor (Typical, R Compressor Shown)

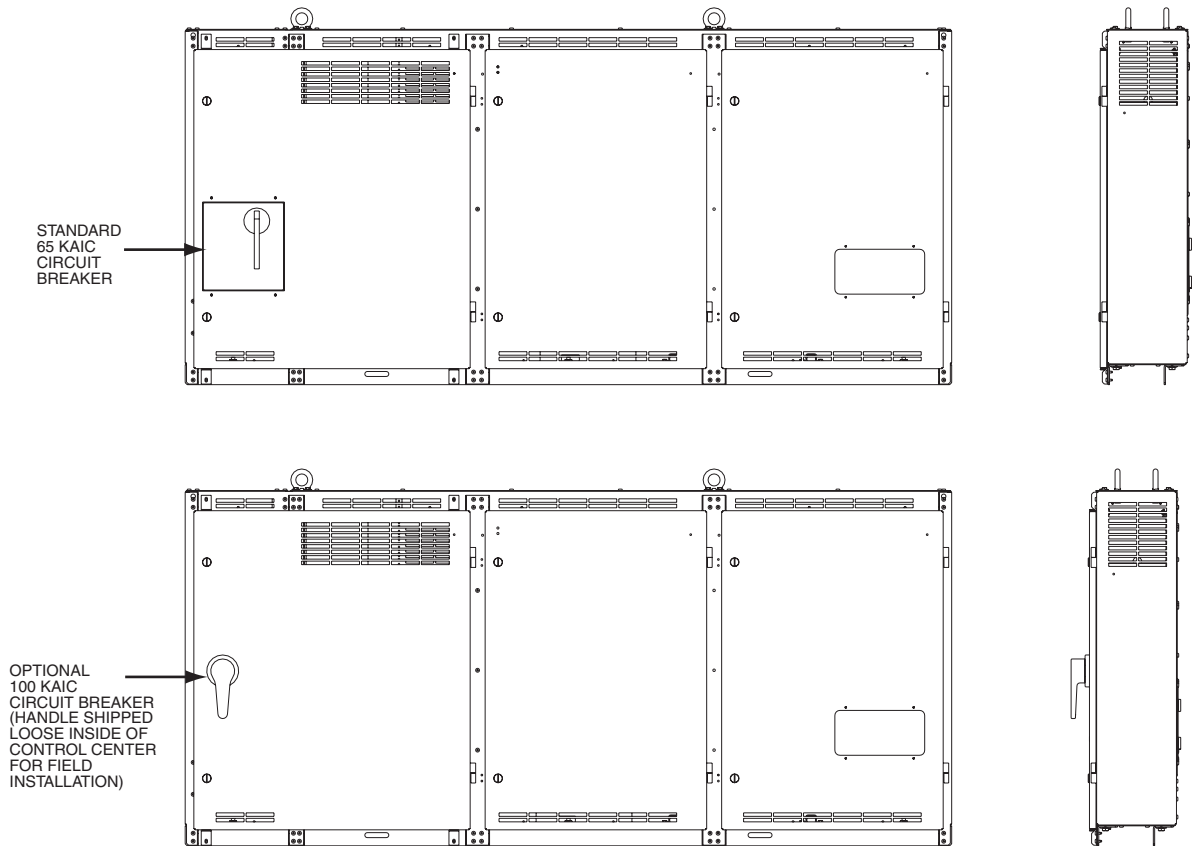

Fig. 9 — Standard and 100-KAIC Circuit Breaker Control Center (R Compressor Shown)

REFRIGERATION CYCLE

The compressor continuously draws refrigerant vapor from the cooler. As the compressor suction reduces the pressure in the cooler, the remaining refrigerant boils at a fairly low temperature (typically 38 to 42 F [3 to 6 C]). The energy required for boiling is obtained from the liquid flowing through the cooler tubes. With heat energy removed, the liquid becomes cold enough for use in an air-conditioning circuit or process liquid cooling.

After absorbing heat from the chilled liquid, the refrigerant vapor is compressed. Compression adds still more energy, and the refrigerant is quite warm (typically 90 to 130 F [32 to 54 C]) when it is discharged from compressor into condenser.

Relatively cool (typically 65 to 85 F [18 to 29 C]) liquid flowing into the condenser tubes removes heat from the refrigerant and the vapor condenses to liquid, refrigerant.

For heat exchangers frame sizes 3-5, the liquid refrigerant in the condenser passes through orifices into the FLASC (Flash Subcooler) chamber (Fig. 10). Since the FLASC chamber is at a lower pressure, part of the liquid refrigerant flashes to vapor, thereby cooling the remaining liquid. The FLASC vapor is recondensed on the tubes which are cooled by entering condenser liquid. The liquid then passes through a float valve assembly

which forms a liquid seal to keep FLASC chamber vapor from entering the cooler.

Heat exchanger frame sizes A and B incorporate a sensible subcooler instead of the FLASC, and the liquid seal and throttle level control are performed by an electronic expansion valve instead of a float valve. See Fig. 11.

An optional economizer can be installed between the condenser and cooler. Pressure in this chamber is intermediate between condenser and cooler pressures. At this lower pressure, some of the liquid refrigerant flashes to gas, cooling the remaining liquid. For heat exchanger frame sizes 3-5, an in-line orifice on the economizer drain flange meters the refrigerant liquid into the cooler. For size A and B heat exchangers, the flash gas to the compressor is produced in a brazed plate heat exchanger where some of the condenser liquid prior to throttling is diverted through the economizer electronic expansion valve (EXV). The EXV control logic is based on economizer saturated temperature, superheat and compressor speed. The flash gas, having absorbed heat, is returned directly to the compressor at a point after suction cutoff (Fig. 12 and 13). Here it is mixed with gas from the suction cut-off point to produce an increase in the mass flow of refrigerant transported and compressed without either an increase in suction volume or a change in suction temperature.

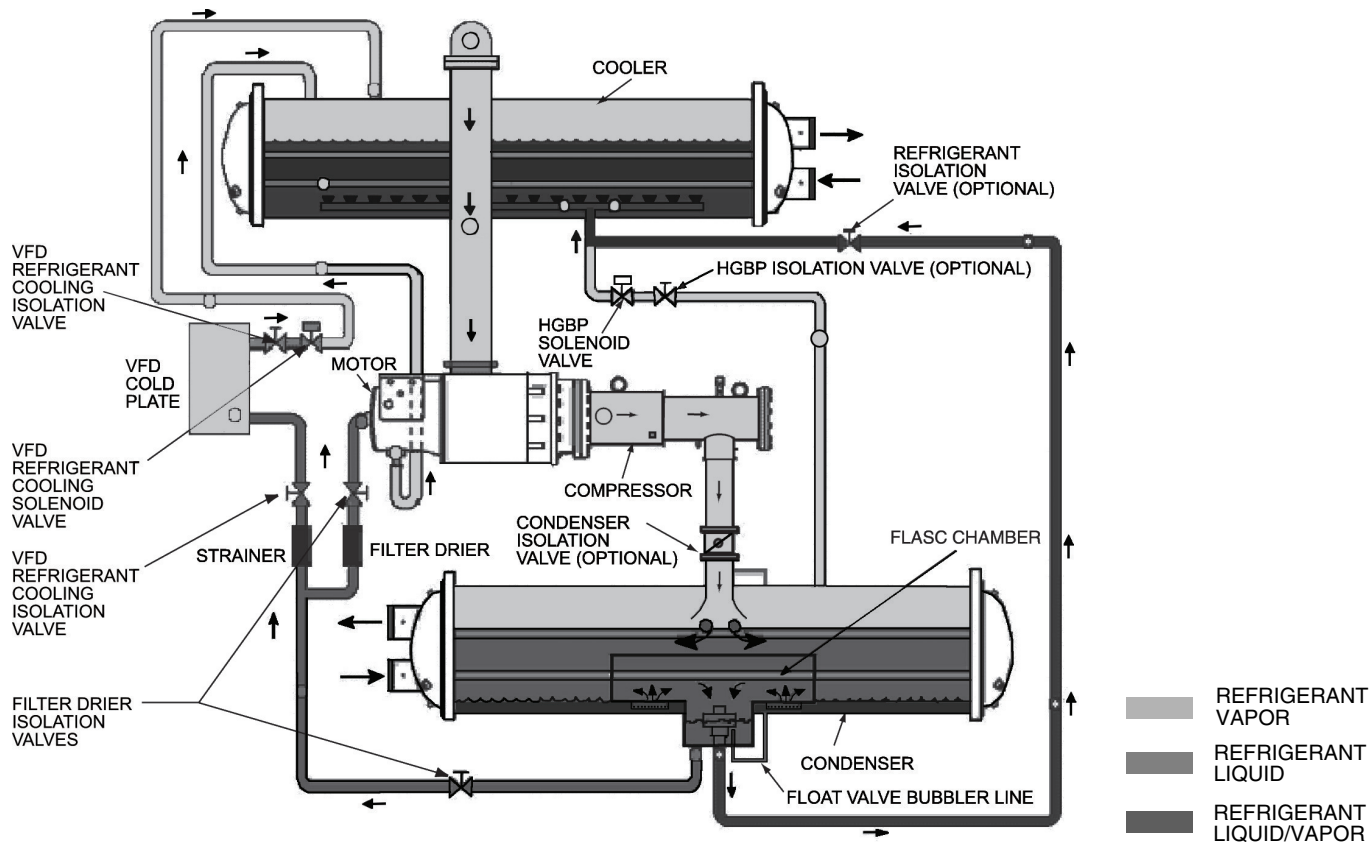

Fig. 10 — Refrigerant Flow Schematic, Q and R Compressors (Without Optional Flash Economizer)

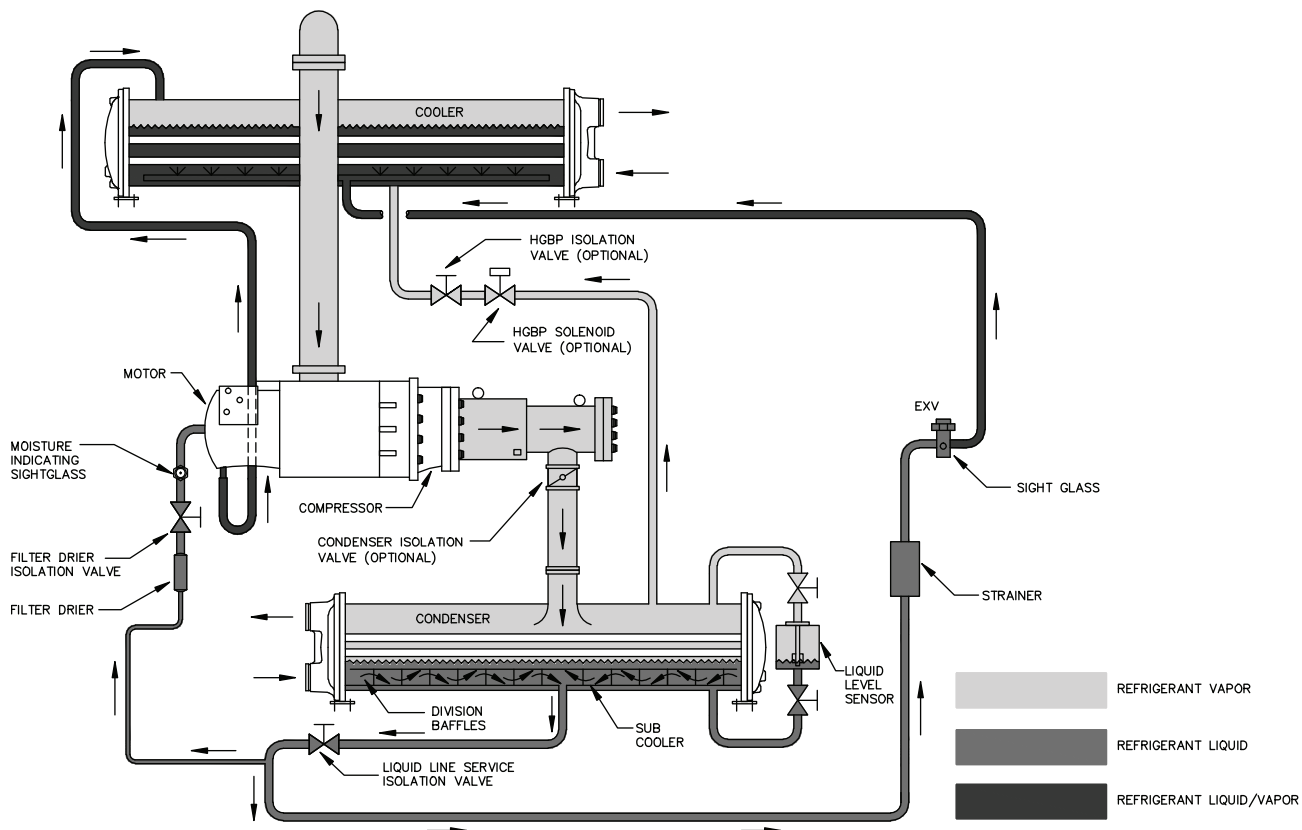

Fig. 11 — Refrigerant Flow Schematic, P Compressor (Without Optional Economizer)

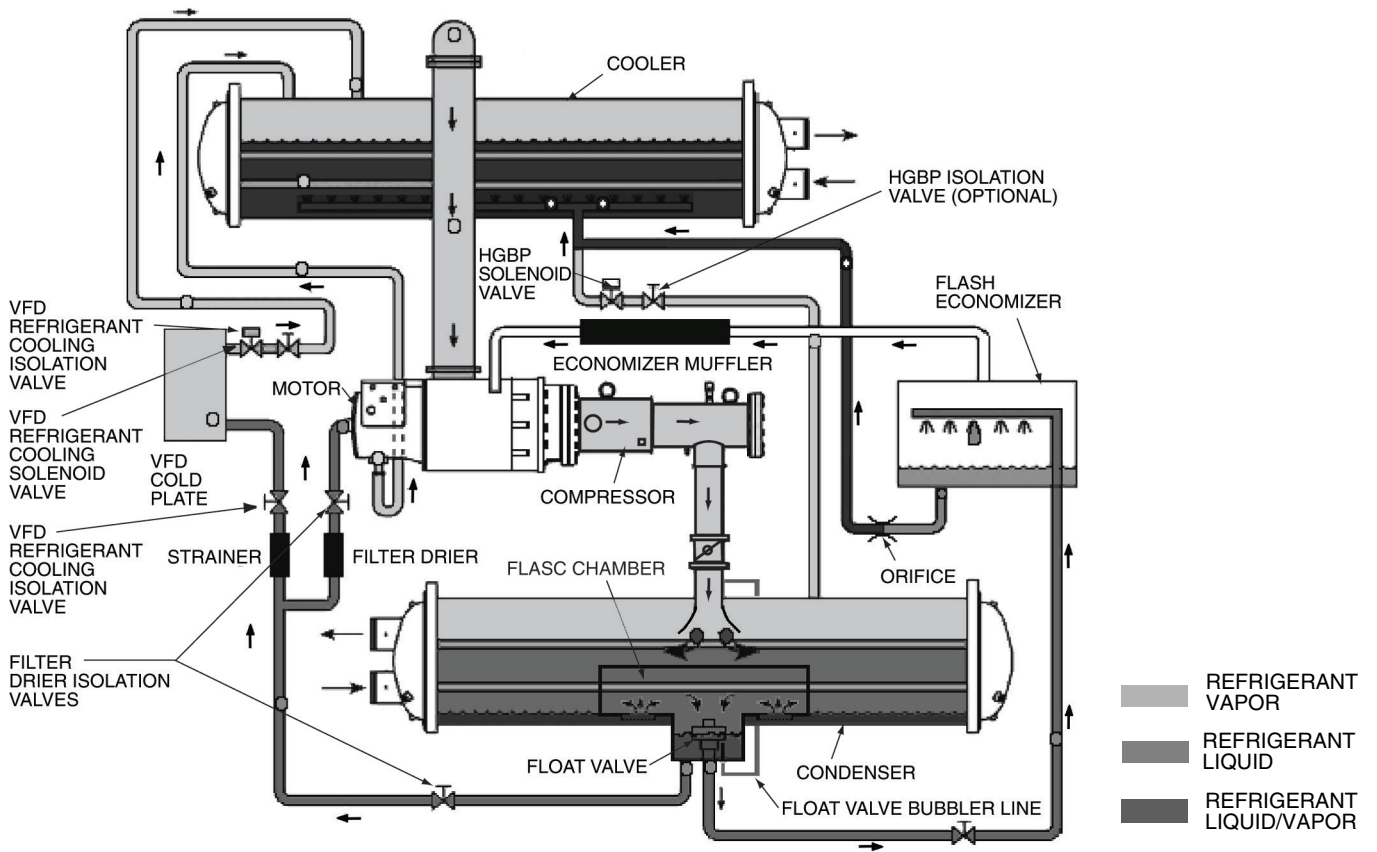

Fig. 12 — Refrigerant Flow Schematic, Q and R Compressors (With Optional Flash Economizer)

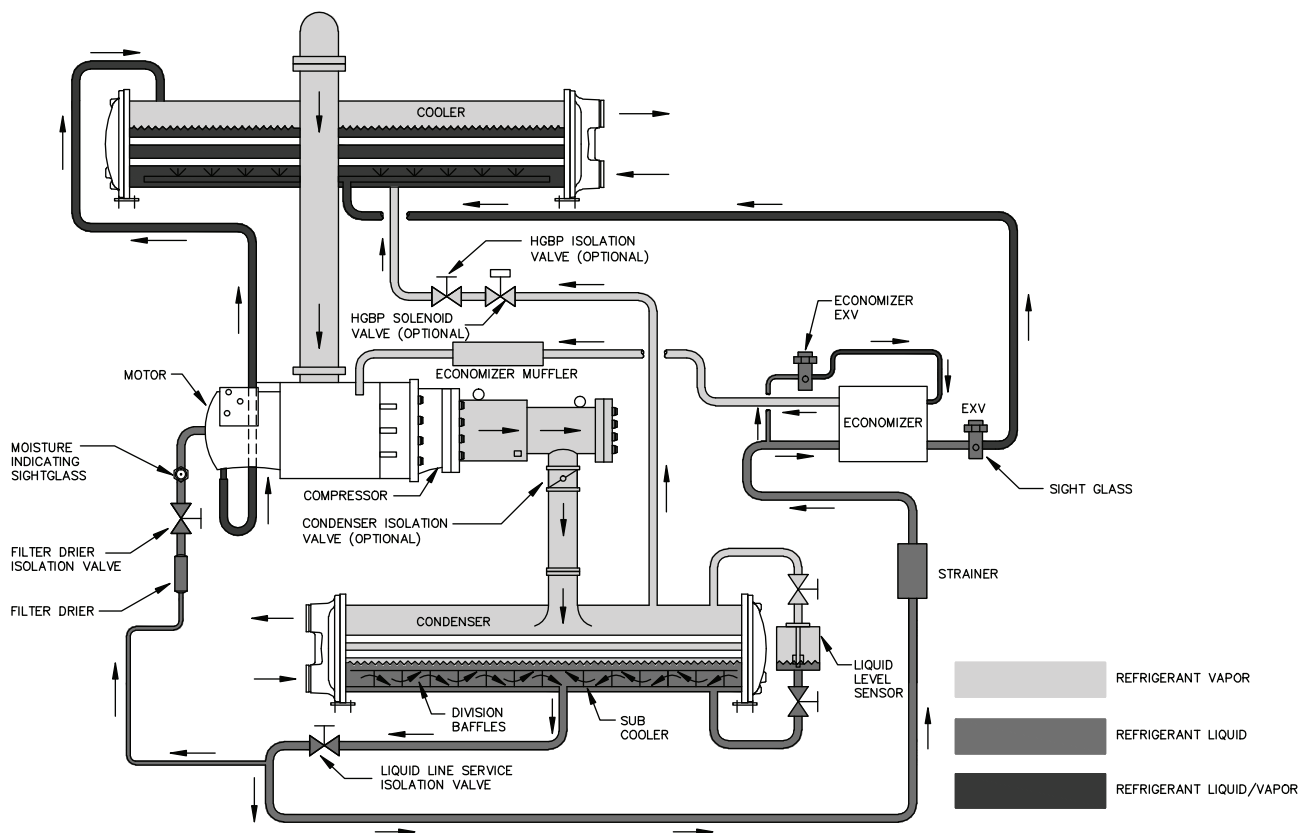

Fig. 13 — Refrigerant Flow Schematic, P Compressor (With Optional Economizer)

MOTOR COOLING CYCLE

For Q and R compressors, one half of the motor is cooled by suction gas while the other half is cooled by liquid refrigerant taken from the bottom of the condenser vessel. The P compressor has two spray nozzles that cool the motor by injecting liquid refrigerant. The flow of liquid refrigerant is maintained by the pressure differential that exists due to compressor operation. The refrigerant flows through an isolation valve, in-line filter/drier, and a sight glass/moisture indicator (dry-eye), into the motor through the motor spray nozzle. See Fig. 10-13.

IMPORTANT: To avoid adverse effects on chiller operation, consideration must be made to condenser water temperature control. Consult the Chiller Builder for required steady state operational limits. Inverted start conditions are acceptable for short durations; generally, for periods exceeding 5 minutes, special control strategy solutions are to be used to allow the chiller to build minimum refrigerant pressure differential (and thereby adequate equipment cooling).

The motor spray nozzle is orificed to control refrigerant flow through the gaps between the rotor and stator. The refrigerant collects in the bottom of the motor casing and then drains into the cooler through the motor cooling drain line.

The motor is protected by a temperature sensor and a temperature switch embedded in the stator windings. *COMP MOTOR WINDING TEMP* temperatures above the *COMP MOTOR TEMP OVERRIDE* threshold (see Capacity Override section, page 48) will override the chilled liquid temperature capacity control to hold. If the motor temperature rises 10° F (5.5 C) above this threshold, the compressor will unload. If the *COMP MOTOR WINDING TEMP* rises above the 220 F (104.4 C) safety limit, the compressor will shut down.

LUBRICATION CYCLE

Summary — The 23XRV chiller requires an oil pump. Oil flow is provided by a magnetically coupled, motor-driven oil pump. Oil flows through the oil filter into the compressor rotors and bearings. The cycle is referred to as a “low side” oil system. See Fig. 14.

Details — The oil system:

- lubricates the roller bearings which support the male and female rotors, and the ball bearings of the 23XRV compressor.
- lubricates the male and female rotors.

Oil is charged into the system through a hand valve located on the bottom of the oil sump. Sight glasses on the oil sump permit oil level observation. When the compressor is shut down, an oil level should be visible in the oil sump sight glass.

During operation, the oil level should always be visible in the oil sump sight glass. Approximately 10 gal. (37.9 L) of oil is charged into the sump.

Oil from the compressor bearing drain is drained directly into the oil sump. Refrigerant is driven from the oil as it flows around the oil sump heater and into the strainer housing. The oil pump draws the oil through a strainer and forces it through an oil filter.

The filter housing is capable of being isolated by upstream and downstream valves to permit filter replacement. An oil pressure regulator valve directs excessive oil back into the oil sump. Oil supplied to the compressor is monitored by an oil pressure sensor. The *OIL PRESSURE DELTA P* value is equal to the difference between the oil pressure leaving the filter and the oil sump pressure. It is read directly from the ICVC (International Chiller Visual Controller) default screen.

Oil is supplied to the compressor through two separate inlets. One inlet leads to the suction bearings, the other leads to the discharge bearings. Most of the oil drains back into the sump while a small amount is used to lubricate the rotors. Rotor lubrication oil leaves the compressor mixed with the compressed discharge refrigerant vapor.

The oil sump contains temperature and pressure sensors and an oil heater. (In some cases a two-stage heater is supplied, with 500 W for the first stage and 1000 W for the second stage.) The oil sump is vented to the compressor suction to minimize the amount of refrigerant absorbed by the oil. The *OIL SUMP TEMPERATURE* is measured and displayed on the ICVC default screen and the COMPRESS screen. The oil sump pressure is used to calculate the *OIL PRESSURE DELTA P* value.

Operating *OIL PRESSURE DELTA P* must be at least 18 psid (124 kPa) after the *OIL PRESS VERIFY TIME* has elapsed. Under normal full load conditions, oil pressure is typically 20 to 28 psid (138 to 193 kPa). If sufficient oil pressure is not established or maintained the chiller will shut down. An oil pressure delta P sensor fault will be declared if the *OIL PRESSURE DELTA P* is not less than 4 psid (27.6 kPa) prior to start-up.

If the oil pressure falls below the values specified in Table 1 during start-up, the PIC III control will shut down the chiller.

Table 1 — Oil Pressure Requirements

TIME (SEC)	MINIMUM START-UP OIL PRESSURE REQUIREMENT	
	HFC-134A	
	PSID	KPA
BEFORE OIL PUMP ON	< 4	27.6
AFTER OIL PRESS VERIFY TIME	18	124
DURING START/RUN	15	103

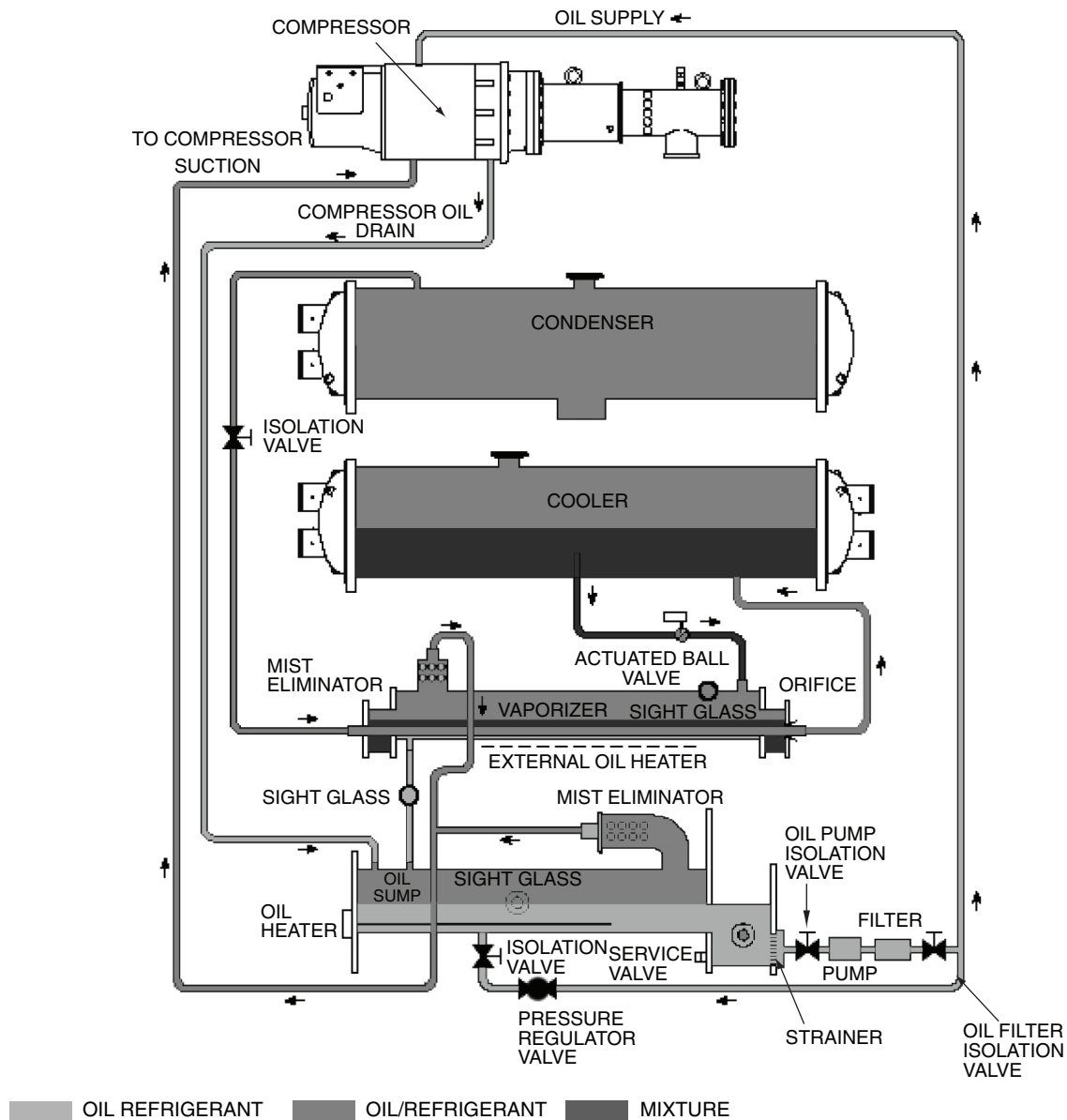

Fig. 14 — Oil Flow Schematic

Oil Reclaim System — The oil reclaim system recovers oil from the cooler, removes the refrigerant, filters and returns the oil back to the compressor. One or more oil reclaim nozzles are positioned along the length of the cooler to draw the oil and refrigerant mixture from the surface of the refrigerant level. The mixture passes through an oil reclaim modulating valve and into the vaporizer. The flow of refrigerant and oil is regulated to prevent the vaporizer from becoming overloaded with liquid refrigerant. The modulating valve position is adjusted in accordance with the difference between the *VAPORIZER TEMP* and the *EVAP REFRIG LIQUID TEMP*. The 4 to 20 mA signal from CCM terminals J8-3 and J8-4 is converted into a 0 to 10V DC input to the oil reclaim modulating valve by a 500-ohm resistor connected between CCM terminals J8-3 and J8-4. The oil reclaim modulating valve closes when the chiller is shut down to prevent the vaporizer and oil sump from being flooded with refrigerant. Do not manually open the oil reclaim modulating valve when the chiller is shut down. Doing so will severely degrade the viscosity of the oil in the sump. Flow of refrigerant and oil from the cooler can be observed through a sight glass on top of the vaporizer.

The viscosity of the compressor oil is significantly reduced when it absorbs refrigerant. A combination of heat and low pressure is used to vaporize the refrigerant that has been absorbed by the oil mixture reclaimed from the cooler. Condenser gas is used to warm the refrigerant and oil mixture in the vaporizer. Warm refrigerant is bled from the top of the condenser, directed through a row of tubes that line the bottom of the vaporizer, and discharged into the cooler. A 1500 W surface mounted electric heater provides supplemental heat to the vaporizer when the compressor is operating at lower loads. Refrigerant boiled out of the reclaimed mixture is vented to the compressor suction. The concentrated oil mixture drains out of the vaporizer, through a sight glass, past the vaporizer temperature sensor, and into the oil sump. (An orifice located between the vaporizer and oil sump maintains the liquid level in the vaporizer.) Additionally the oil sump heater maintains the temperature of the reclaimed oil and the oil returned from the compressor at approximately 90 F (32.2 C) when the chiller is running and 140 F (60 C) when the chiller is off. The oil sump is also vented to compressor suction to increase oil viscosity by boiling off additional refrigerant.

Capacity Control — The PIC III controls provide chilled liquid temperature control by modulating the frequency of the power delivered by the VFD to the compressor motor. The compressor speed is adjusted in response to the difference between the *CONTROL POINT* and the *LEAVING CHILLED LIQUID* or *ENTERING CHILLED LIQUID* temperatures.

The PIC III controls respond to the difference between the *CONTROL POINT* and *LEAVING CHILLED LIQUID* temperatures when the *ECL CONTROL OPTION* is *DISABLED*.

The PIC III controls respond to the difference between the *CONTROL POINT* and *ENTERING CHILLED LIQUID* temperatures when the *ECL CONTROL OPTION* is *ENABLED*.

The chiller capacity is controlled by varying the *TARGET VFD SPEED* from 0% to 100%. The PIC III controls monitor the compressor oil properties and set a *COMPRESSOR MINIMUM SPEED* to ensure sufficient compressor bearing lubrication under all operating conditions.

CONTROLS

Definitions

ANALOG SIGNAL — *An analog signal* varies in proportion to the monitored source. It quantifies values between operating limits. (Example: A temperature sensor is an analog device because its resistance changes in proportion to the temperature, generating many values.)

DISCRETE SIGNAL — *A discrete signal* is a two-position representation of the value of a monitored source. (Example: A switch produces a discrete signal indicating whether a value is above or below a set point or boundary by generating an on/off, high/low, or open/closed signal.)

General Controls Overview — The 23XRV hermetic screw liquid chiller contains a microprocessor-based control center that monitors and controls all operations of the chiller. The microprocessor control system matches the cooling capacity of the chiller to the cooling load while providing state-of-the-art chiller protection. The system controls cooling capacity within the set point plus the deadband by sensing the leaving chilled liquid or brine temperature (see Fig. 15 and 16) and regulating the compressor speed. Reducing the compressor speed decreases the volume flow rate of refrigerant through the compressor. Chiller protection is provided by the PIC III processor, which monitors the digital and analog inputs and executes capacity overrides or safety shutdowns, if required.

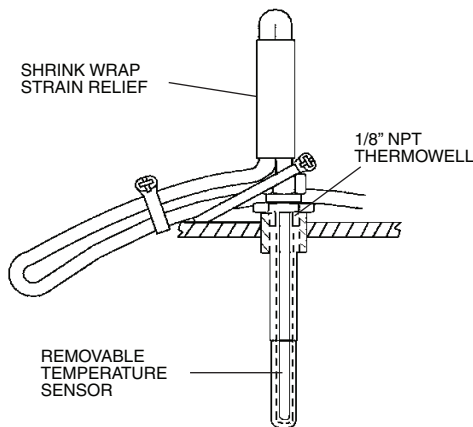

Fig. 15 — Control Sensors (Temperature)

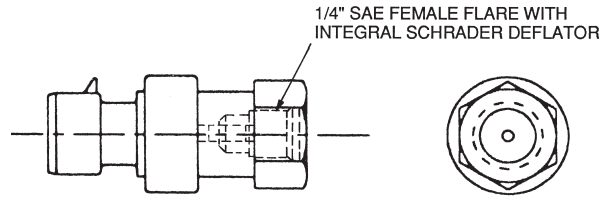

Fig. 16 — Control Sensors (Pressure Transducers)

PIC III System Components (Fig. 17-23) — The chiller control system is called PIC III (Product Integrated Control III). See Table 2. The PIC III control system controls the chiller by monitoring all operating conditions. The PIC III control can diagnose a problem and let the operator know what the problem is and what to check. It promptly adjusts compressor speed to maintain leaving chilled liquid temperature. It can interface with auxiliary equipment such as pumps and cooling tower fans to turn them on when required. It continually checks all safeties to prevent any unsafe operating condition. It also regulates the oil heater and regulates the hot gas bypass valve, if installed. The PIC III controls provide critical protection for the compressor motor and control of the variable frequency drive.

The PIC III control system can interface with the Carrier Comfort Network® (CCN) system if desired. It can also communicate with other PIC I, PIC II or PIC III equipped chillers and other CCN devices, such as LEI (Local Equipment Interface).

The PIC III controls are housed inside the control center enclosure. See Fig. 2-4. The component names are listed below (also see Table 2):

INTERNATIONAL CHILLER VISUAL CONTROLLER (ICVC) — The ICVC is the “brain” of the PIC III control system. This module contains all the primary software needed to control the chiller. The ICVC is the input center for all local chiller set points, schedules, configurable functions, and options. The ICVC has a stop button, an alarm light, four buttons for logic inputs, and a backlight display. The backlight will automatically turn off after 15 minutes of non-use. The functions of the four buttons or “softkeys” are menu driven and are shown on the display directly above the softkeys. The ICVC is mounted on the control center door. See Fig. 2-4.

To change the contrast of the display, access the adjustment on the back of the ICVC. See Fig. 17.

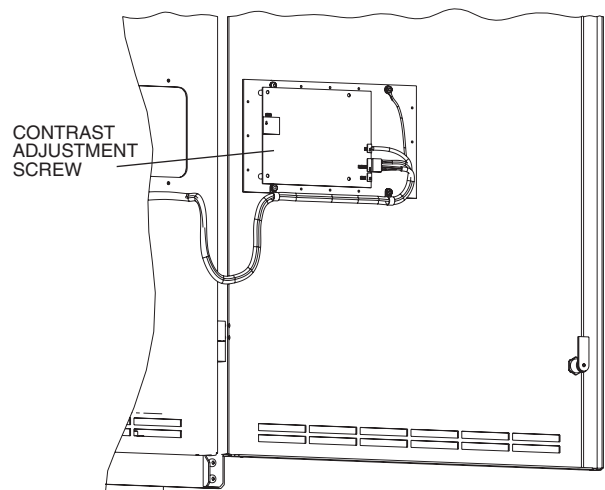

Fig. 17 — ICVC Contrast Adjustment

CHILLER CONTROL MODULE (CCM) — This module is located on the control panel in the control center. The CCM provides the input and outputs necessary to control the chiller. This module monitors refrigerant pressure, entering and leaving liquid temperatures and pressures, and outputs control for the oil reclaim valve, oil heaters, and oil pump. The CCM is the connection point for optional demand limit, automatic chilled liquid reset, 4 to 20 mA kW output, remote temperature reset, and refrigerant leak sensor.

VFD POWER MODULE — This module is located in the control center. The A/C line I/O assembly executes commands from the ICVC for functions such as starting and stopping the condenser and evaporator liquid pumps, tower fan and alarm contacts. The Standard I/O Option Assembly monitors inputs such as remote start contact, spare safety, and the high condenser pressure switch and provides the 4-20 mA Head Pressure Reference Output. See Fig. 18 for control center layout for the LF-2 VFD. See Fig. 19 for control center layout for Std Tier VFD.

VFD GATEWAY MODULE — The VFD Gateway Module translates the protocols between the ICVC, CCM and VFD. This module also contains logic capable of an independent safety shutdown. It shuts down the chiller if communications with the ICVC are lost. See Fig. 20 for power module component locations.

OIL HEATER CONTACTOR (1C) — This contactor is located on the control panel (Fig. 21) and operates the heater at 115 V. It is controlled by the PIC III control system to maintain oil temperature during chiller shutdown or to keep the oil sump temperature at an acceptable level.

OIL PUMP CONTACTOR (2C) — This contactor is located in the control panel (Fig. 21) and operates the oil pump. The oil pump is controlled by the PIC III to provide oil pressure during pre-lube and when the chiller is starting or running.

HOT GAS BYPASS CONTACTOR RELAY (3C) (Optional) — This relay, located in the power panel, controls the opening of the hot gas bypass valve. The PIC III energizes the relay based on hot gas bypass algorithm settings.

SECOND STAGE OIL HEATER CONTACTOR (5C) — This contactor is located in the control panel (Fig. 22), and is activated by PIC III to maintain oil quality at low temperature.

VAPORIZER HEATER CONTACTOR (6C) — This contactor is located in the control panel (Fig. 21) and energizes the surface mounted heater on the bottom of the vaporizer.

CONTROL TRANSFORMERS (T1, T2, T4) — Transformers T1, T2 convert incoming control voltage to 24 vac power for the power panel contactor relays, CCM, ICVC, and 21 vac power for the optional UPC Open and LON modules. Transformer T4 (supplied only with P compressors) supplies power to both the EXV and AUX1 boards. Circuit breakers CB-1A, CB-1B, CB-2A and CB-2B for the control transformers are located above the CCM.

EXV CONTROL MODULE (PD4-EXV) — This module is supplied with P compressors only. It is located near the top of the control panel near the T4 control transformer. It provides the input and outputs for the condenser EXV, economizer EXV and economizer gas temperature.

AUXILIARY CONTROL MODULE (PD4-AUX1) — This module is supplied with P compressors only. It is located near the PD4-EXV board. This board communicates with the PD4-EXV board and the CCM board, and provides the input and output for the condenser level sensor (0 to 5 v proportional signal).

ELECTRONIC EXPANSION VALVE (P Compressors Only, Heat Exchanger Frame Size A and B) — High pressure refrigerant enters the EXV and goes through the variable orifice. Refrigerant flow control for different operating conditions is controlled by an actuator that modulates the valve opening. The stepper motor moves in increments and is controlled by the EXV control module. As the stepper motor rotates, motion is transferred into linear movement by the lead screw. The main EXV stepper motor has 3810 total steps, while the optional economizer EXV has 2625 steps. See Fig. 23.

Main EXV Control — The valve is modulated to achieve the condenser level set point by a continuous loop that compares desired level to sensed level. At initial start-up the valve position is driven to the start position and is held at this position for approximately 2 minutes or as defined by the start delay setting, after which the level control algorithm takes over. After shutdown, the EXV will be driven to the condenser EXV start position which will allow pressure equalization between cooler and condenser. Default control parameters can be adjusted in SETUP5.

NOTE: Changing the default values of many of the values in SETUP4 and SETUP5 associated with the EXV control is not recommended without support from Service Engineering.

Economizer EXV Control (Option) — The economizer EXV is activated at approximately 75% speed or as configured when Actual VFD Speed is greater than Economizer Activate Speed. After this, it is controlled to maintain the economizer superheat set point that provides gas flow to the compressor. When it deactivates, or if the Economizer Option is disabled, the valve is fully closed. If the Economizer Option is enabled then the EXV control logic algorithm will be active 5 minutes after completion of startup. Default parameters can be adjusted in SETUP4.

NOTE: Changing the default values of many of the values in SETUP4 and SETUP5 associated with the EXV control is not recommended without support from Service Engineering.

CONDENSER LEVEL SENSOR (P Compressors Only, Heat Exchanger Frame Size A and B) — This sensor monitors the liquid level in the condenser and transmits a continuous 0 to 5 v signal proportional to the liquid level in the condenser sensing chamber. See Fig. 5.

Table 2 — Major PIC III Control Components and Panel Locations

PIC III COMPONENT	PANEL LOCATION
International Chiller Visual Controller (ICVC) and Display	Control Center Door
VFD Power Module	Inside Control Center
Chiller Control Module (CCM)	Control Panel
Oil Heater Contactor (1C)	Control Panel
Oil Heater Contactor, 1000 W (5C)	Control Panel
Oil Pump Contactor (2C)	Control Panel
Hot Gas Bypass Relay (3C) (Optional)	Control Panel
Control Transformers (T1, T2)	Control Panel
Control Transformer Circuit Breakers (CB-1A, CB-1B, CB-2A, CB-2B)	Control Panel
EXV Control Transformer (T4)	See Fig. 22
Temperature Sensors	See Fig. 5-7 and 15
Condenser Level Sensor	See Fig. 5
Pressure Transducers	See Fig. 5-7 and 16
Vaporizer Heater Contactor (6C)	Control Panel
Auxiliary Control Module	Near PD-4 EXV Board

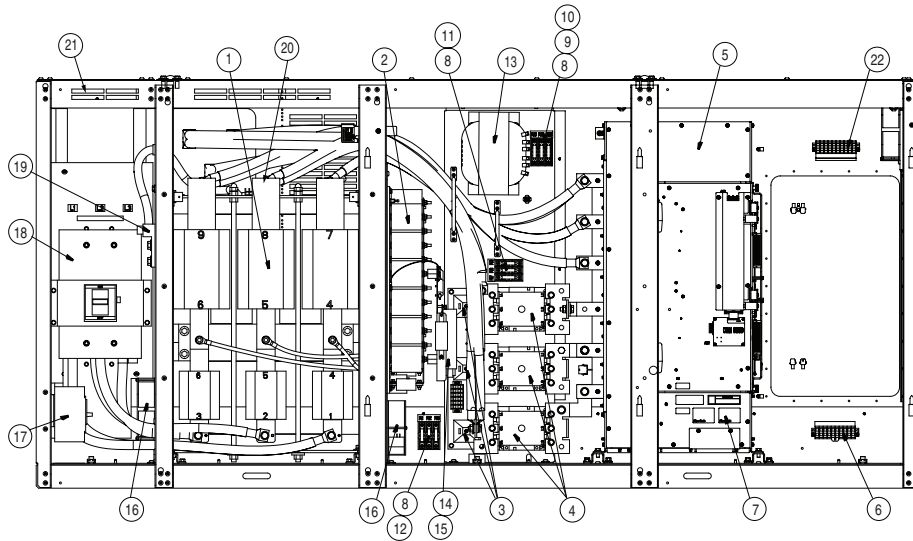

FUSE REF	FUSE DESCRIPTION
FU1	CLASS CC, 1A/600V
FU2	CLASS CC, 1A/600V
FU3	CLASS CC, 1A/600V
FU4	150A/600V
FU5	150A/600V
FU6	150A/600V
FU7	CLASS CC, 20A/600V
FU8	CLASS CC, 20A/600V
FU9	CLASS CC, 20A/600V
FU10	CLASS CC, 5A/600V
FU11A&B	CLASS CC, 15A/600V

LEGEND

- | | |
|---|---|
| 1 — Input Inductor Assembly | 12 — Fuse, Class CC, 600V, 1A (3) |
| 2 — Capacitor Bank Assembly | 13 — Transformer, 3kVA |
| 3 — Pre-Charge Resistor Assembly | 14 — Line Sync PC Board Assembly |
| 4 — AC Contactor (3) | 15 — Line Sync Board Cover |
| 5 — Power Module Assembly | 16 — Fan, 115V (3) |
| 6 — Terminal Block, 10-Position (Extra Low Voltage) | 17 — Control Power Circuit Breaker, 600V, 15A |
| 7 — Power Module Assembly | 18 — Circuit Breaker, 600V |
| 8 — Fuse Block, 30A, 600V, Class CC | 19 — Lug, Ground, 2-600 MCM |
| 9 — Fuse, Class CC, 600V, 15A (2) | 20 — Inductor Overtemperature Switch (Hidden) |
| 10 — Fuse, Class CC, 600V, 5A (1) | 21 — Input Power Wiring Access Panel |
| 11 — Fuse, Class CC, 600V, 20A (3) | 22 — Terminal Block (Hazardous voltage) |

Fig. 18 — Control Center VFD Input Components (LF-2 VFD)

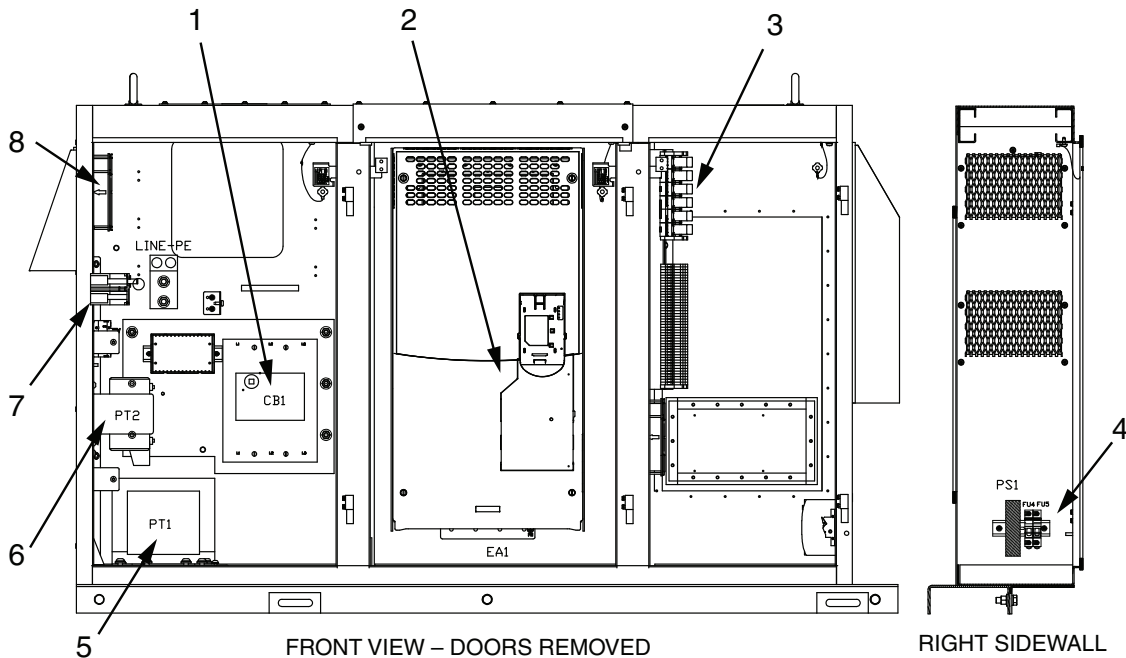

LEGEND

- | |
|---------------------------------------|
| 1 — Input Circuit Breaker |
| 2 — Power Module |
| 3 — Control Relays (CR1 - CR6) |
| 4 — Control Fuses |
| 5 — 120V Control Transformer |
| 6 — 120V Vaporizer Heater Transformer |
| 7 — 15 Amp Control Circuit Breaker |
| 8 — Cooling Fan |

Fig. 19 — Control Center VFD Input Components (Std Tier VFD)

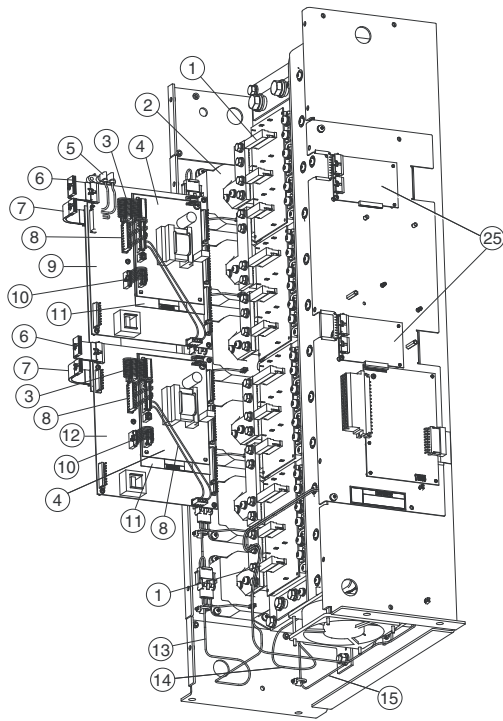

Door Open

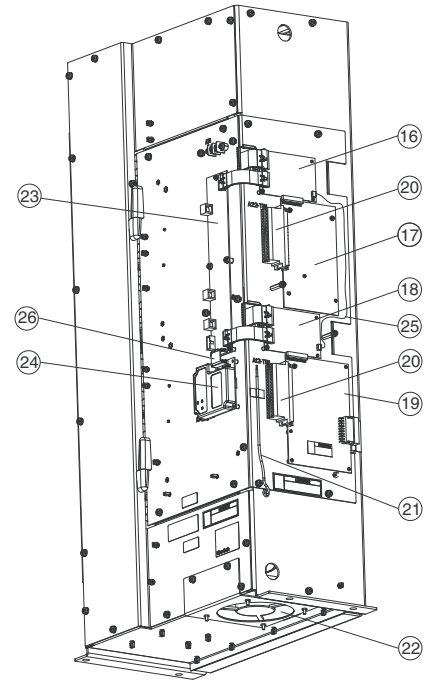

Door Closed

LEGEND

- | | |
|--|--|
| 1 — Wire Harness Assembly, Gate Driver | 14 — Wire Harness Assembly, DC Bus Bleeder Resistors |
| 2 — Current Feedback Device, 1000 A | 15 — Wire Harness Assembly, Line Sync |
| 3 — Wire Harness Assembly, Power Supply, Logic | 16 — Inverter Control Assembly* |
| 4 — 80 W Power Supply Assembly | 17 — Standard I/O Option, 24 V Assembly |
| 5 — Terminal Block, 2-Position | 18 — Rectifier Control Assembly* |
| 6 — Cable Assembly, 40-Pin | 19 — AC Line I/O Assembly |
| 7 — Cable Assembly, 30-Pin | 20 — Connector, Terminal Block, 32-Pin |
| 8 — Wire Harness Assembly, Power Supply, Upper Gate | 21 — NTC Assembly |
| 9 — Inverter Power Interface Assembly | 22 — Internal Fan |
| 10 — Wire Harness Assembly, Power Supply, Lower Gate | 23 — DPI Communications Interface Assembly |
| 11 — Insulation Sheet | 24 — RS-485 Communications Assembly (VFD Gateway) |
| 12 — Rectifier Power Interface Assembly | 25 — Wire Harness Assembly, Control Sync |
| 13 — Wire Harness Assembly, Current Feedback Device | 26 — Cable Assembly, 20-pin |

*The inverter control assembly (item 16) and rectifier control assembly (item 18) are physically similar but are loaded with different software. These boards are NOT interchangeable.

Fig. 20 — Power Module Components

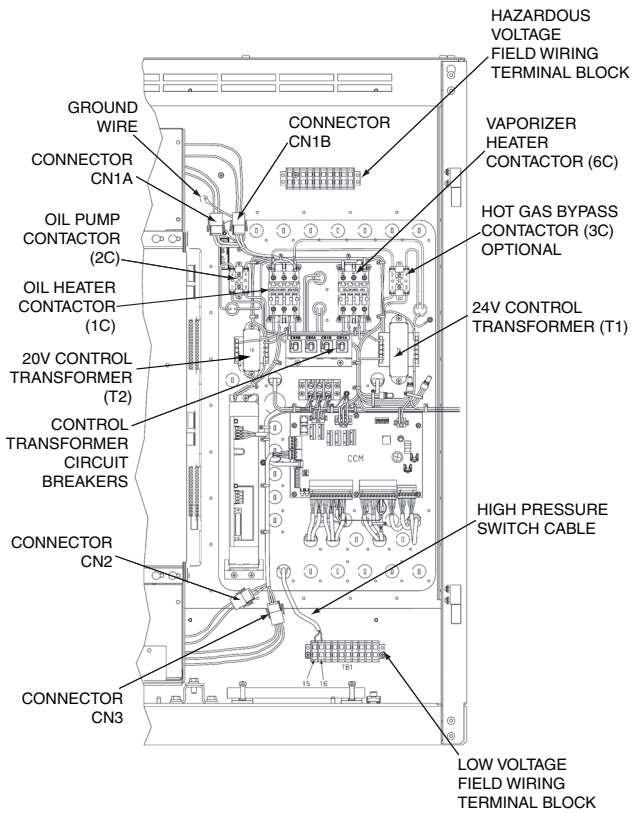

Fig. 21 — Control Panel (Q, R Units with LF-2 VFD)

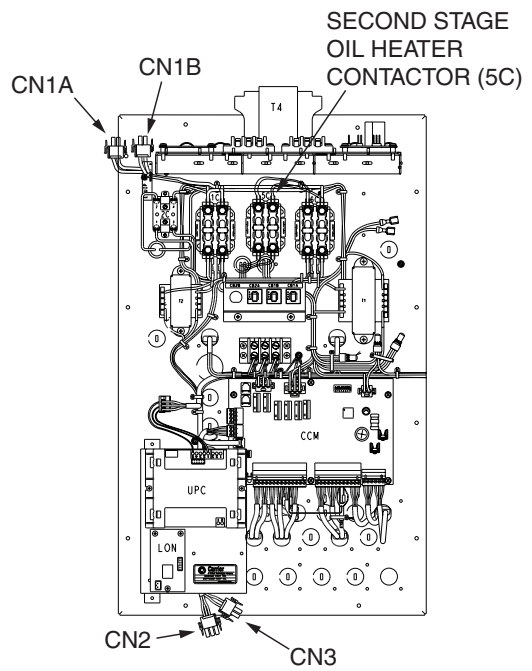

Fig. 22 — Control Panel (P Units)

1. Cable
2. Glass Seal
3. Motor Housing
4. Stepper Motor
5. Bearing
6. Lead Screw
7. Insert
8. Valve Piston
9. Valve Seat
10. Valve Port

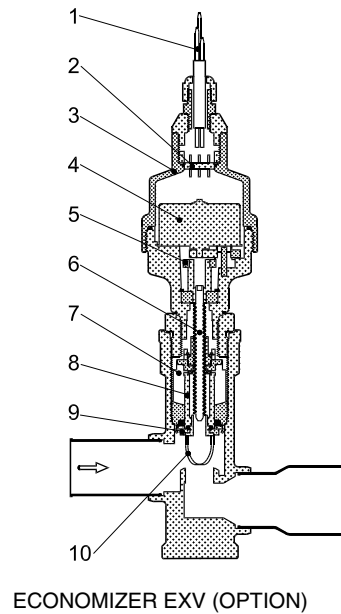
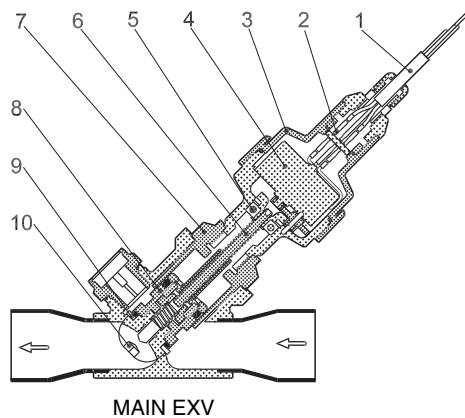

Fig. 23 — Cutaway Views of Electronic Expansion Valves (EXV) (P Compressor Only)

ICVC Operation and Menus (Fig. 24-30)

GENERAL

- The ICVC display automatically reverts to the default screen after 15 minutes if no softkey activity takes place (Fig. 24).
- If a screen other than the default screen is displayed on the ICVC, the name of that screen is in the upper right corner (Fig. 25).
- The ICVC may be set to display either English or SI units. Use the ICVC CONFIGURATION screen (accessed from the SERVICE menu) to change the units. See the Service Operation section, page 59.
- Local Operation — The PIC III can be placed in local operating mode by pressing the **[LOCAL]** softkey. The PIC III then accepts commands from the ICVC only and uses the Local Time Schedule to determine chiller start and stop times.
- CCN Operation — The PIC III can be placed in the CCN operating mode by pressing the **[CCN]** softkey. The PIC III then accepts modifications from any CCN interface or module (with the proper authority), as well as from the ICVC. The PIC III uses the CCN Time Schedule to determine start and stop times.

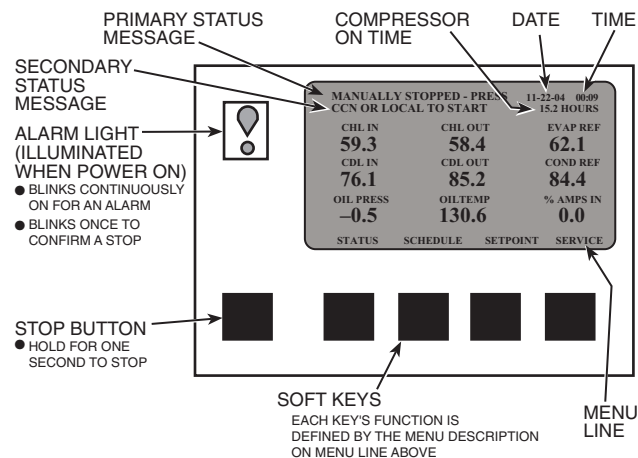

Fig. 24 — ICVC Default Screen

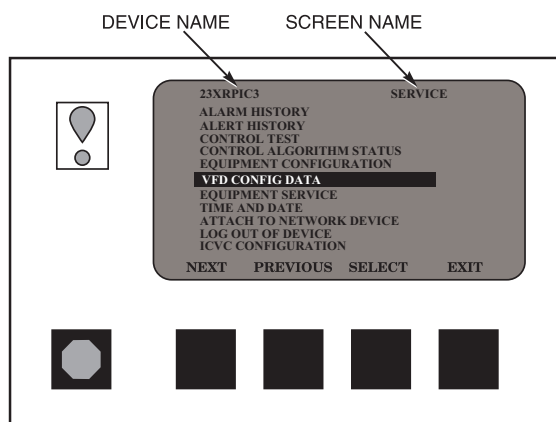

Fig. 25 — ICVC Service Screen

ALARMS AND ALERTS — An alarm shuts down the compressor. An alert does not shut down the compressor, but it notifies the operator that an unusual condition has occurred. An

alarm (*) or alert (!) is indicated in the STATUS column on the right side of the MAINSTAT display screen. See Fig. 26.

Alarms are indicated when the control center alarm light (!) flashes. The primary alarm message is displayed on the default screen. An additional, secondary message and troubleshooting information are sent to the ALARM HISTORY screen.

When an alarm is detected, the ICVC default screen will freeze (stop updating) at the time of alarm. The freeze enables the operator to view the chiller conditions at the time of alarm. Additional information is stored in the VFD_HIST screen. The STATUS tables will show the updated information. Once all alarms have been cleared (by pressing the **[RESET]** softkey), the default ICVC screen will return to normal operation.

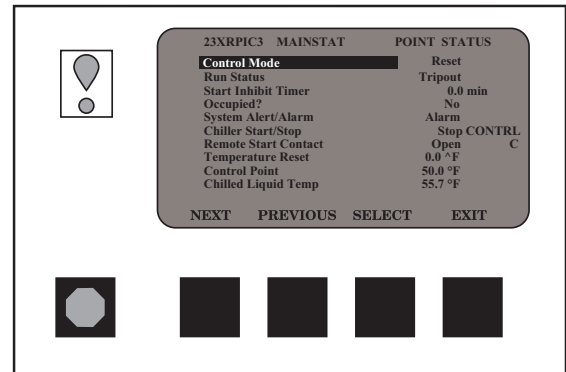

Fig. 26 — Example of MAINSTAT Screen

ICVC MENU ITEMS — To perform any of the operations described below, the PIC III must be powered up and have successfully completed its self test. The self test takes place automatically, after power-up.

Press the **[MENU]** softkey to view the list of menu structures: **[STATUS]**, **[SCHEDULE]**, **[SETPOINT]**, and **[SERVICE]**.

- The STATUS menu allows viewing and limited calibration or modification of control points and sensors, relays and contacts, and the options board.
- The SCHEDULE menu allows viewing and modification of the local and CCN Time Schedules.
- The SETPOINT menu allows set point adjustments, such as the ENTERING CHILLED LIQUID and LEAVING CHILLED LIQUID set points.
- The SERVICE menu can be used to view or modify information on the ALARM HISTORY, ALERT HISTORY, CONTROL TEST, CONTROL ALGORITHM STATUS, EQUIPMENT CONFIGURATION, VFD CONFIG DATA, EQUIPMENT SERVICE, TIME AND DATE, ATTACH TO NETWORK DEVICE, LOG OUT OF DEVICE, and ICVC CONFIGURATION screens.

For more information on the menu structures, refer to Fig. 27 and 28.

Press the softkey that corresponds to the menu structure to be viewed: **[STATUS]**, **[SCHEDULE]**, **[SETPOINT]**, or **[SERVICE]**. To view or access parameters within any of these menu structures, use the **[NEXT]** and **[PREVIOUS]** softkeys to scroll to the desired item or table. Use the **[SELECT]** softkey to select that item. The softkey choices that then appear depend on the selected table or menu. The softkey choices and their functions are described in the section Basic ICVC Operations beginning on page 24.

BASIC ICVC OPERATIONS (Using the Softkeys) — To perform any of the operations described below, the PIC III must be powered up and have successfully completed its self test.

- Press **QUIT** to leave the selected decision or field without saving any changes.



- Press **ENTER** to leave the selected decision or field and save changes.



- Press **NEXT** to scroll the cursor bar down in order to highlight a point or to view more points below the current screen.

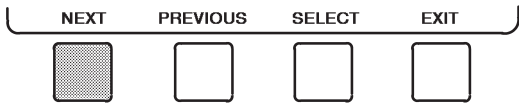

- Press **PREVIOUS** to scroll the cursor bar up in order to highlight a point or to view points above the current screen.

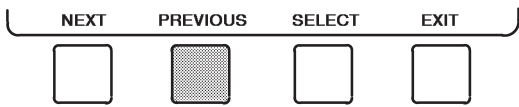

- Press **SELECT** to view the next screen level (highlighted with the cursor bar), or to override (if allowable) the highlighted point value.

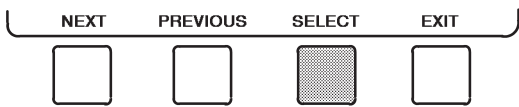

- Press **EXIT** to return to the previous screen level.

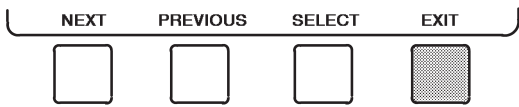

- Press **INCREASE** or **DECREASE** to change the highlighted point value.

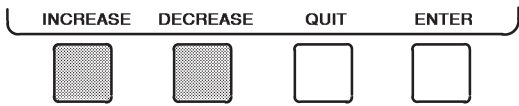

TO VIEW STATUS (Fig. 27) — The MAINSTAT table shows the actual value of overall chiller status such as CONTROL MODE, RUN STATUS, AUTO CHILLED LIQ RESET, and REMOTE RESET SENSOR.

1. On the menu screen, press **STATUS** to view the list of point status tables.

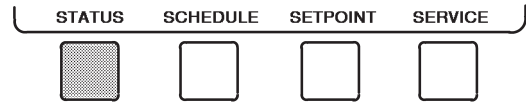

2. Press **NEXT** or **PREVIOUS** to highlight the desired status table. The list of tables is:

- MAINSTAT — Overall chiller status
- STARTUP — Status required to perform start-up of chiller
- COMPRESS — Status of sensors related to the compressor
- HEAT_EX — Status of sensors related to the heat exchangers
- POWER — Status of motor input power
- ECON_EXV — Status of economizer EXV control sensors (if applicable)
- COND_EXV — Status of condenser EXV control sensors (if applicable)
- VFD_STAT — Status of the variable frequency drive
- ICVC_PWD — Service menu password forcing access screen

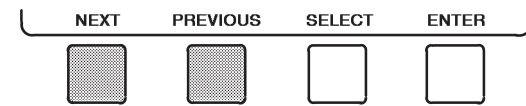

3. Press **SELECT** to view the desired point status table.

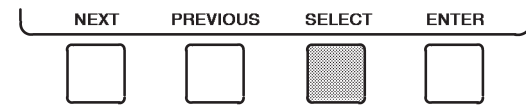

4. On the point status table, press **NEXT** or **PREVIOUS** until the desired point is displayed on the screen.

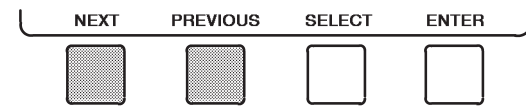

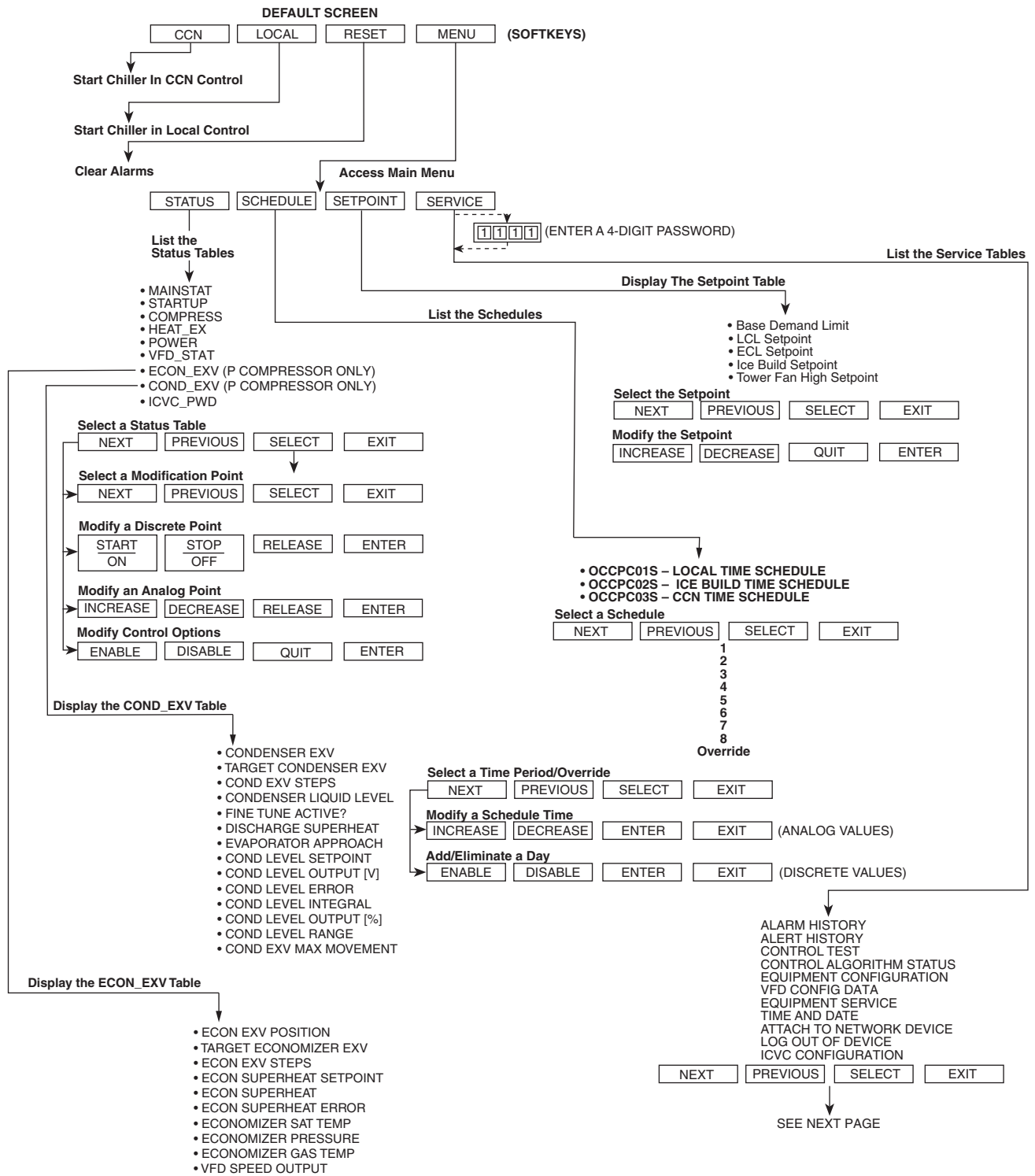

NOTE: The ICVC menu structure and tables shown in this manual are for Q/R Compressors CESR-131293-04 Version 4 and for P Compressors CESR-131584-05 Version 2. This applies throughout the manual.

Fig. 27 — 23XRV ICVC Menu Structure

SERVICE TABLE

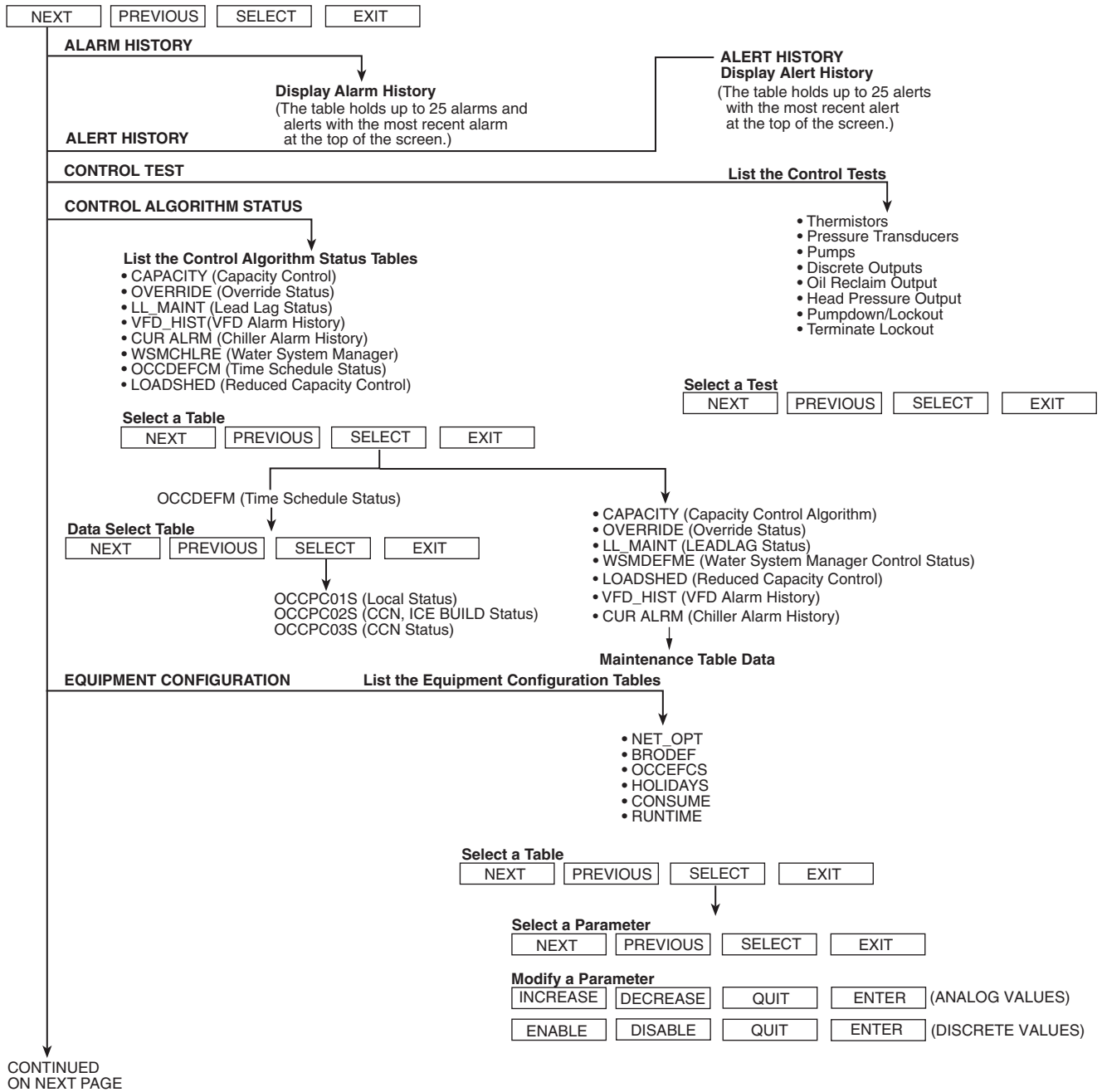
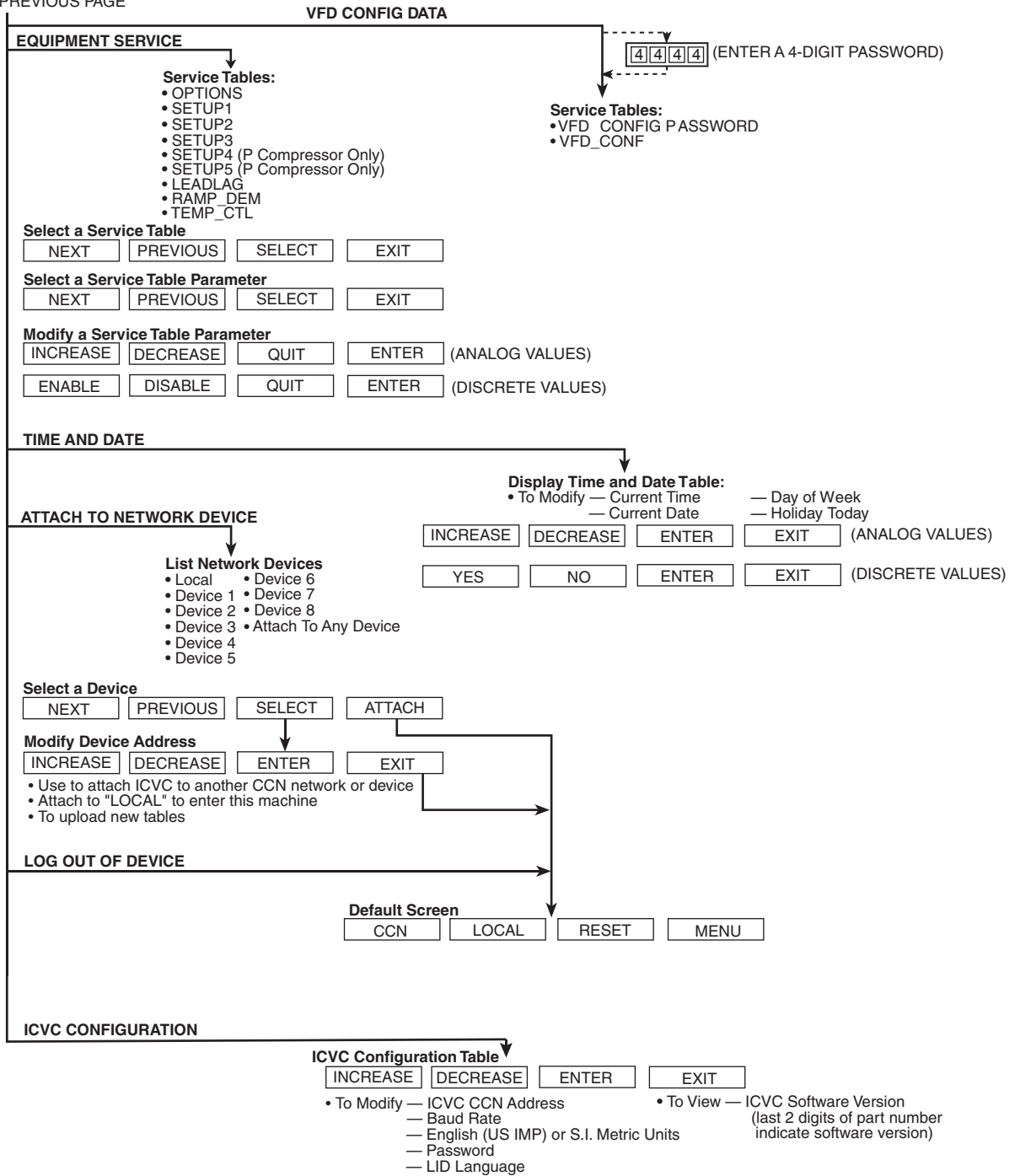

Fig. 28 — 23XRV ICVC Service Menu Structure



- LEGEND**
- CCN** — Carrier Comfort Network®
 - ICVC** — International Chiller Visual Controller
 - IMP** — Imperial
 - VFD** — Variable Frequency Drive
 - PIC III** — Product Integrated Control III

Fig. 28 —23XRV ICVC Service Menu Structure (cont)

OVERRIDE OPERATIONS

To Override a Value or Status

1. From any point status screen, press **NEXT** or **PREVIOUS** to highlight the desired value.

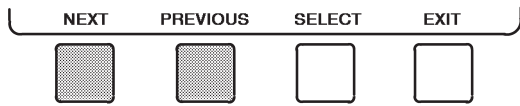

2. Press **SELECT** to select the highlighted value. Then:

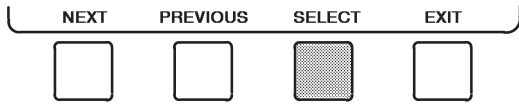

For Discrete Points — Press **YES** or **NO** to select the desired state.

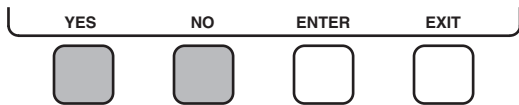

For Analog Points — Press **INCREASE** or **DECREASE** to select the desired value.

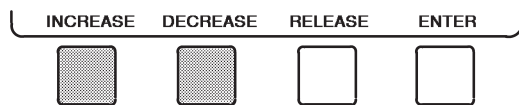

3. Press **ENTER** to register the new value.

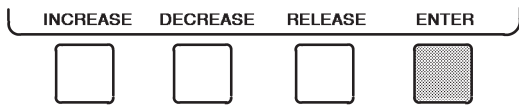

NOTE: When overriding or changing metric values, it is necessary to hold down the softkey for a few seconds in order to see a value change, especially on kilopascal values.

To Remove an Override

1. On the point status table press **NEXT** or **PREVIOUS** to highlight the desired value.

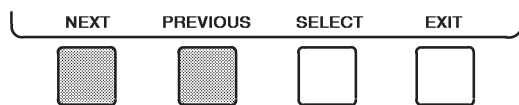

2. Press **SELECT** to access the highlighted value.

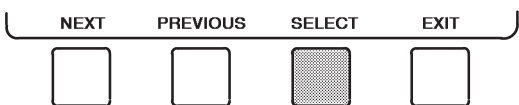

3. Press **RELEASE** to remove the override and return the point to the PIC III's automatic control.

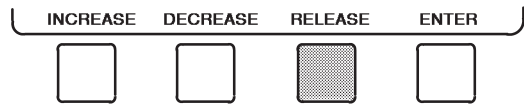

Override Indication — An override value is indicated by “SUPVSR,” “SERVC,” or “BEST” flashing next to the point value on the STATUS table.

TIME SCHEDULE OPERATION (FIG. 29)

1. On the Menu screen, press **SCHEDULE**.

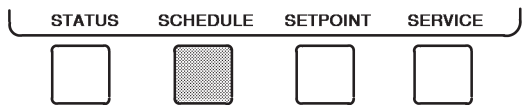

2. Press **NEXT** or **PREVIOUS** to highlight the desired schedule.

OCCPC01S — LOCAL Time Schedule
 OCCPC02S — ICE Build Schedule
 OCCPC03S — CCN Time Schedule

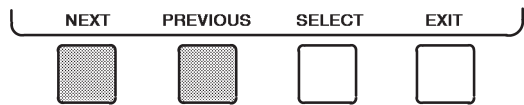

3. Press **SELECT** to view the desired time schedule.

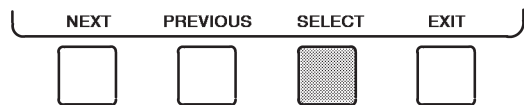

4. Press **NEXT** or **PREVIOUS** to highlight the desired period or override to change.

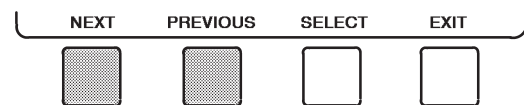

5. Press **SELECT** to access the highlighted period or override.

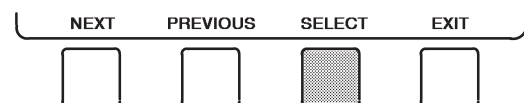

6. a. Press **INCREASE** or **DECREASE** to change the time values. Override values are in one-hour increments, up to 4 hours.

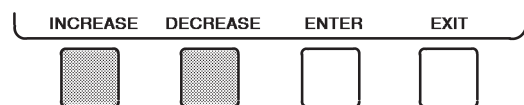

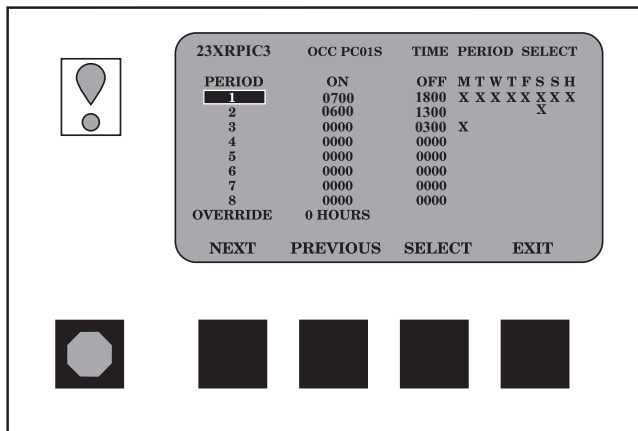
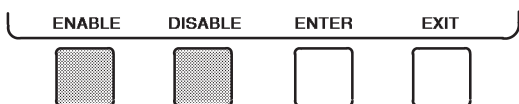
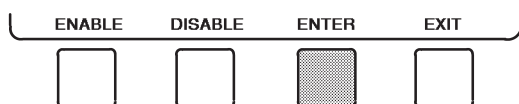

Fig. 29 — Example of Time Schedule Operation Screen

b. Press **[ENABLE]** to select days in the day-of-week fields. Press **[DISABLE]** to eliminate days from the period.



7. Press **[ENTER]** to register the values and to move horizontally (left to right) within a period.



8. Press **[EXIT]** to leave the period or override.

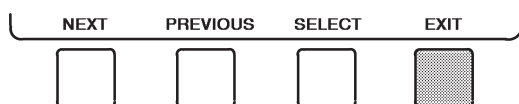

9. Either return to Step 4 to select another period or override, or press **[EXIT]** again to leave the current time schedule screen and save the changes.

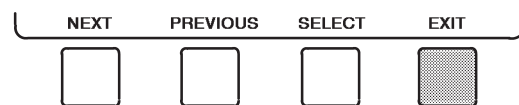

10. The Holiday Designation (HOLIDAYS table) may be found in the Service Operation section, page 59. The month, day, and duration for the holiday must be assigned. The TIME BROADCAST ENABLE function in the BRODEF screen also must be enabled for holiday periods to function.

TO VIEW AND CHANGE SET POINTS (Fig. 30)

1. To view the SETPOINT table, from the MENU screen press **[SETPOINT]**.

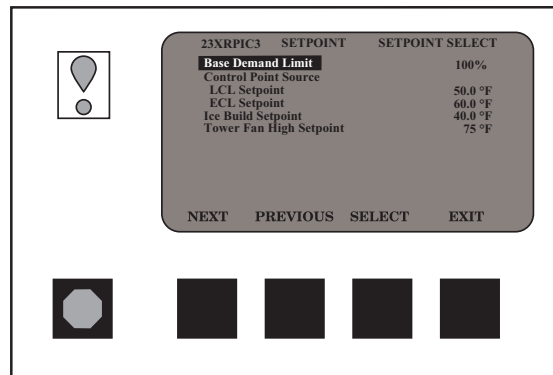
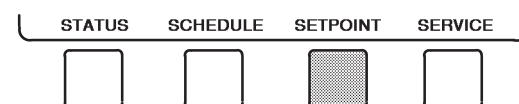
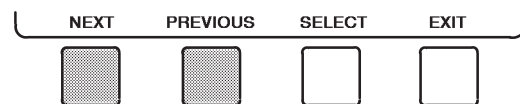

Fig. 30 — Example of Set Point Screen

2. There are 5 set points on this screen: BASE DEMAND LIMIT, LCL SETPOINT (leaving chilled liquid set point), ECL SETPOINT (entering chilled liquid set point), ICE BUILD SETPOINT and TOWER FAN HIGH SETPOINT. Only one of the CONTROL POINT SOURCES (LCL or ECL) can be active at one time. The control point source that is active is determined from the TEMP_CTL screen. See the Service Operation section, page 59.

3. Press **[NEXT]** or **[PREVIOUS]** to highlight the desired set point entry.



4. Press **[SELECT]** to modify the highlighted set point.

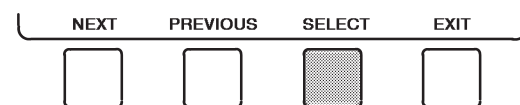

5. Press **[INCREASE]** or **[DECREASE]** to change the selected set point value.

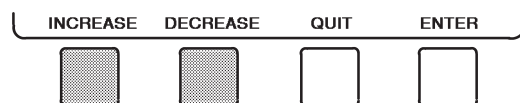

6. Press **[ENTER]** to save the changes and return to the previous screen.

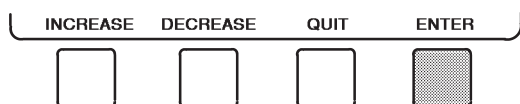

SERVICE OPERATION — To view the menu-driven programs available for Service Operation, see the Service Operation section, page 59. For examples of ICVC display screens, see Table 3.

Table 3 — ICVC Display Data

IMPORTANT: The following notes apply to all Table 3 examples.

1. Only 12 lines of information appear on the ICVC screen at any one time. Press the **[NEXT]** or **[PREVIOUS]** softkey to highlight a point or to view items below or above the current screen. Double-click the **[NEXT]** softkey to page forward; double-click the **[PREVIOUS]** softkey to page back.
2. To access the information shown in Examples 12 through 29, enter your 4-digit password after pressing the **[SERVICE]** softkey. If no softkeys are pressed for 15 minutes, the ICVC automatically logs off (to prevent unrestricted access to PIC III controls) and reverts to the default screen. If this happens, you must re-enter your password to access the tables shown in Examples 12 through 29.
3. Terms in the Description column of these tables are listed as they appear on the ICVC screen.
4. The ICVC may be configured in English or Metric (SI) units using the ICVC CONFIGURATION screen. See the Service Operation section, page 59, for instructions on making this change.
5. The items in the Reference Point Name column *do not appear on the ICVC screen*. They are data or variable names used in CCN, Building Systems Interface (BSI) or Local Equipment Interface (LEI) Module software (optional). They are listed in these tables as a convenience to the operator if it is necessary to cross reference CCN/BSI documentation or use CCN/BSI programs. For more information, see the CCN literature.
6. Reference Point Names shown in these tables in all capital letters can be read by CCN and BSI software. Of these capitalized names, those variables preceded by a * can also be changed (that is, written to) by the CCN, BSI, LEI, and the ICVC. Variables preceded by a

dagger shall support one time write operations for the ICVC only when the value is initially zero. Variables preceded by two asterisks can be changed only from the ICVC. Reference Point Names in lower case type can be viewed by CCN or BSI only by viewing the whole table.

7. Alarms and Alerts: An asterisk *in the far right field of a ICVC status screen* indicates that the chiller is in an alarm state; an exclamation point in the far right field of the ICVC screen indicates an alert state. The asterisk (or exclamation point) indicates that the value on that line has exceeded (or is approaching) a limit. For more information on alarms and alerts, see the Alarms and Alerts section, page 23.
8. Index of all ICVC Parameters is shown in Appendix A.

LEGEND

- 1CR** — Control Relay
- CCN** — Carrier Comfort Network®
- CHL** — Chilled Liquid
- CR** — Control Relay
- CT** — Current Transformer
- I2T** — Motor Overload
- ICVC** — International Chiller Visual Controller
- ECL** — Entering Chilled Liquid
- HGBP** — Hot Gas Bypass
- LCL** — Leaving Chilled Liquid
- LRA** — Locked Rotor Amps
- mA** — Milliamps
- P** — Pressure
- T** — Temperature
- VFD** — Variable Frequency Drive
- WSM** — Liquid System Manager
- ° F** — Temperature in Degrees Fahrenheit
- ^ F** — Temperature Difference in Degrees Fahrenheit

EXAMPLE 1 — ICVC DEFAULT SCREEN

The following data is displayed in the ICVC Default screen.

DESCRIPTION	RANGE	UNITS	REFERENCE POINT NAME (ALARM HISTORY)	DISPLAY
(PRIMARY MESSAGE)				
(SECONDARY MESSAGE)				
(DATE AND TIME)				
Compressor Ontime	0 to 500000.0	HOURS	C_HRS	
Entering Chilled Liquid	-40 to 245	°F (°C)	ECL	CHL IN
Leaving Chilled Liquid	-40 to 245	°F (°C)	LCL	CHL OUT
Evaporator Refrigerant Temperature (See Note 1)	-40 to 245	°F (°C)	ERT_EST	EVAP REF
Entering Condenser Liquid	-40 to 245	°F (°C)	ECDL	CDL IN
Leaving Condenser Liquid	-40 to 245	°F (°C)	LCDL	CDL OUT
Condenser Refrigerant Temperature	-40 to 245	°F (°C)	CRT	COND REF
Oil Pressure Delta P	-6.7 to 425	psi (kPa)	OIL_PD	OILPRESS
Oil Sump Temp	-40 to 245	°F (°C)	OILT	OIL TEMP
Percent Line Current	0 to 999	%	AMPS_P	% AMPS IN
CCN	0 to 1		CCN	
LOCAL	0 to 1		LOCAL	
RESET	0 to 1		RESET	

NOTES:

1. The Evaporator Refrigerant Temperature displayed is the smaller value of EVAP REFRIG LIQUID TEMP or CALC EVAP SAT TEMP.
2. The last three entries are used to indicate operating mode to the PIC III. These values may be forced by the ICVC only.

Table 3 — ICVC Display Data (cont)

EXAMPLE 2 — MAINTSTAT DISPLAY SCREEN

To access this display from the **ICVC default** screen:

1. Press **[MENU]**.
2. Press **[STATUS]** (**[MAINSTAT]** will be highlighted).
3. Press **[SELECT]**.

DESCRIPTION	STATUS	UNITS	POINT
Control Mode	NOTE 2	NOTE 2	MODE
Run Status	NOTE 3	NOTE 3	STATUS
Start Inhibit Timer	0 to 15	min	T_START
Occupied ?	0/1	NO/YES	OCC
System Alert/Alarm	0-2	NOTE 4	SYS_ALM
*Chiller Start/Stop	0/1	STOP/START	CHIL_S_S
*Remote Start Contact	0/1	OPEN/CLOSE	REMCON
Temperature Reset	-30 to 30	^F (^C)	T_RESET
*Control Point	10 to 65	°F (°C)	LCW_STPT
Chilled Liquid Temp	-40 to 245	°F (°C)	CHL_TMP
*Active Demand Limit	40 to 100	%	DEM_LIM
Percent Line Current	0.0 to 9999	%	LN_AMPS_P
Percent Line Kilowatts	0.0 to 9999	%	LINE KW_P
Auto Demand Limit Input	4 to 20	mA	AUTODEM
Auto Chilled Liq Reset	4 to 20	mA	AUTORES
Remote Reset Sensor	-40 to 245	°F (°C)	R_RESET
†Total Compressor Starts	0 to 99999		C_STARTS
Starts in 12 Hours	0 to 8		STARTS
†Compressor Ontime	0 to 500000.0	HOURS	C_HRS
**Service Ontime	0 to 32767.0	HOURS	S_HRS
Ice Build Contact	0/1	OPEN/CLOSE	ICE_CON
Refrigerant Leak Sensor PPM	0.0 to 9999.0	mA	REF_LEAK
Emergency Stop	0/1	ENABLE/EMSTOP	EMSTOP
ALARM RELAY	NORMAL/ALARM		ALM

NOTES:

1. Numbers in parentheses indicate the equivalent CCN BEST++™ programming LEI or BACnet Translator use.
2. Off (0), Local (1), CCN (2), Reset (3)
3. Timeout (0), Ready (1), Recycle (2), Startup (3), Running (4), Demand (5), Ramping (6), Auto Restart (7), Override (8), Tripout (9), Control Test (10), Lockout (11), Pumpdown (12), Prestart (13)
4. Normal (0), Alert (1), Alarm (2).
5. All variables with capital letter point names are available for CCN read operation.
 Those shown with (*) support write operations for all CCN and LEI devices.
 Those shown with (†) shall support one time write operations for the ICVC only when the value is initially zero.
 Those shown with (**) shall support write operations for the ICVC only.

EXAMPLE 3 — STARTUP DISPLAY SCREEN

To access this display from the **ICVC default** screen:

1. Press **[MENU]**.
2. Press **[STATUS]**.
3. Scroll down to highlight **[STARTUP]**.
4. Press **[SELECT]**.

DESCRIPTION	STATUS	UNITS	POINT
**Chilled Liquid Pump	0/1	OFF/ON	CHLP
Chilled Liquid Flow	0/1	NO/YES	CHL_FLOW
**Condenser Liquid Pump	0/1	OFF/ON	CDP
Condenser Liquid Flow	0/1	NO/YES	CDL_FLOW
Oil Pump Relay	0/1	OFF/ON	OILR
Oil Reclaim Output	0 to 100.0	% (4 to 20mA)	OIL_MA
**Oil Pressure Delta P	-6.7 to 200	psi (kPa)	OILPD
Oil Sump Temp	-40.0 to 245.0	°F (°C)	OILT
Vaporizer Temp	-40.0 to 245.0	°F (°C)	VAP_TEMP
VFD Start	0/1	NO/YES	VFDSTART
Start Complete	0/1	FALSE/TRUE	START_OK
Stop Complete	0/1	FALSE/TRUE	STOP_OK
VFD Speed Output	0.0 to 100.0	%	VFD_OUT
Comp Motor RPM	0 to 300000	rpm	CPR_RPM
Comp Motor Frequency	0 to 10000	Hz	VFD_FREQ
Comp Maximum Speed	0 to 110	Hz	MAXSPEED
Comp Minimum Speed	0 to 100	%	MINSPEED
**Tower Fan Relay Low	0/1	OFF/ON	TFR_LOW
**Tower Fan Relay High	0/1	OFF/ON	TFR_HIGH
Spare Safety Input	0/1	ALARM/NORMAL	SAFETY
Shunt Trip Relay	0/1	OFF/ON	TRIPR

NOTE: All variables with CAPITAL LETTER point names are available for CCN read operation.
 Those shown with (**) shall support write operations for the ICVC only.

Table 3 — ICVC Display Data (cont)

EXAMPLE 4 — COMPRESS DISPLAY SCREEN

To access this display from the ICVC default screen:

1. Press **[MENU]**.
2. Press **[STATUS]**.
3. Scroll down to highlight **[COMPRESS]**.
4. Press **[SELECT]**.

DESCRIPTION	STATUS	UNITS	POINT
Actual VFD Speed	0 to 115	%	VFD_ACT
Compressor Motor RPM	0 to 300000	rpm	CPR_RPM
Compressor Motor Frequency	0 to 10000	Hz	VFD_FREQ
Compressor Maximum Speed	0 to 101	Hz	MAXSPEED
Compressor Minimum Speed	0 to 100	%	MINSPEED
VFD Delta	-2 to 2	%	VFDDELTA
**Target VFD Speed	0 to 100	%	VFD_TRG
VFD Speed Output	0 to 100	%	VFD_OUT
Oil Pump Relay	0/1	OFF/ON	OILR
**Oil Pressure Delta P	-6.7 to 420	psi (kPa)	OILPD
Oil Sump Temp	-40 to 245	°F (°C)	OILT
Vaporizer Temperature	-40 to 245	°F (°C)	VAP_TEMP
Oil Heater Relay	0/1	OFF/ON	OILHEAT
Vaporizer Heater	0/1	OFF/ON	VAP_HEAT
Comp Motor Winding Temp	-40 to 245	°F (°C)	MTRW
Comp Discharge Temp	-40 to 245	°F (°C)	CMPD
Discharge Superheat	-20 to 999	^F (^C)	SUPRHEAT
Stall Protection Counts	0 to 5		SPC
Spare Temperature 1	-40 to 245	°F (°C)	SPARE_T1
Spare Temperature 2	-40 to 245	°F (°C)	SPARE_T2

NOTE: All variables with CAPITAL LETTER point names are available for CCN read operation; those with (**) shall support write operations for ICVC only.

EXAMPLE 5 — HEAT_EX DISPLAY SCREEN

To access this display from the ICVC default screen:

1. Press **[MENU]**.
2. Press **[STATUS]**.
3. Scroll down to highlight **[HEAT_EX]**.
4. Press **[SELECT]**.

DESCRIPTION	STATUS	UNITS	POINT
**Chilled Liquid Delta P	-6.7 to 420	psi (kPa)	CHLPD
Entering Chilled Liquid	-40 to 245	°F (°C)	ECL
Leaving Chilled Liquid	-40 to 245	°F (°C)	LCL
Chilled Liquid Delta T	-40 to 245	^F (^C)	CHL_DT
Chill Liq Pulldown/Min	-20 to 20	^F (^C)	CHL_PULL
Calc Evap Sat Temp	-40 to 245	°F (°C)	ERT
**Evaporator Pressure	-6.7 to 420	psi (kPa)	ERP
Evap Refrig Liquid Temp	-40 to 245	°F (°C)	EST
Evaporator Approach	0 to 99	^F (^C)	EVAP_APP
**Condenser Liquid Delta P (N/A for P Compressor)	-6.7 to 420	psi (kPa)	CDLPD
Entering Cond Liquid	-40 to 245	°F (°C)	ECDL
Leaving Cond Liquid	-40 to 245	°F (°C)	LCDL
Condenser Refrig Temp	-40 to 245	°F (°C)	CRT
**Condenser Pressure	-6.7 to 420	psi (kPa)	CRP
Condenser Approach	0 to 99	^F (^C)	COND_APP
Vaporizer Temp	-40 to 245	°F (°C)	VAP_TEMP
Reclaim Delta T	-500 to 500	^F (^C)	R_DELTA
Oil Reclaim Output	0 to 100	%	OIL_MA
VFD Coolant Flow	0 to 100	%	VFD_FOUT
Hot Gas Bypass Relay	0/1	OFF/ON	HGBYPASS
Active Delta P	0 to 200	psi (kPa)	DP_A
Active Delta T	0 to 200	^F (^C)	DT_A
HGBP Delta T	0 to 200	^F (^C)	DT_C
Head Pressure Reference	0 to 100	%	HPR

NOTE: All variables with CAPITAL LETTER point names are available for CCN read operation; those with (**) shall support write operations for ICVC only.

Table 3 — ICVC Display Data (cont)

EXAMPLE 6 — ECON_EXV DISPLAY SCREEN (FOR P COMPRESSOR ONLY)

Applies to units enabled with EXV throttle control enabled.

To access this display from the **ICVC default** screen:

1. Press **MENU**.
2. Press **STATUS**.
3. Scroll down to highlight **ECON_EXV**.
4. Press **SELECT**.

DESCRIPTION	STATUS	UNITS	POINT
** Econ EXV Position	0 to 100	%	ECON_EXV
Target Economizer EXV	0.0 to 100	%	EEXV_TRG
Econ EXV Steps	-160 to 100.0	%	ECONSTEP
Econ Superheat Setpoint	0.0 to 30.0 (0.0 to 16.7)	^F (^C)	ECONSHSP
Econ Superheat	0.0 to 30.0 (0.0 to 16.7)	^F (^C)	ECON_SH
Econ Superheat Error	0.0 to 30.0 (0.0 to 16.7)	^F (^C)	SH_ERR
Economizer Sat Temp	-40 to 245 (-22.2 to 136.1)	°F (°C)	ECON_SAT
Economizer Pressure	-6.7 to 420 (-46.2 to 2895.8)	psi (kPa)	ECON_PRS
Economizer Gas Temp	-40 to 245 (-22.2 to 136.1)	°F (°C)	ECON_GAS
VFD Speed Output	0.0 to 100.0	%	VFD_OUT

NOTE: All variables with CAPITAL LETTER point names are available for CCN read operation; those with (**) shall support write operations for ICVC only.

EXAMPLE 7 — COND_EXV DISPLAY SCREEN (FOR P COMPRESSOR ONLY)

Applies to units enabled with EXV throttle control enabled.

To access this display from the **ICVC default** screen:

1. Press **MENU**.
2. Press **STATUS**.
3. Scroll down to highlight **COND_EXV**.
4. Press **SELECT**.

DESCRIPTION	STATUS	UNITS	POINT
** Condenser EXV	0 to 100	%	COND_EXV
Target Condenser EXV	0.0 to 100	%	CEXV_TRG
Cond EXV Steps	-160 to 100.0	%	CONDSTEP
Condenser Liquid Level	0 to 5	V	COND_LEV
Fine Tune Active?	Y/N		FT_ACTIVE
Discharge Superheat			DSH
Evaporator Approach			EVAP_APP
Cond LevelSetpoint	0 to 5	V	LEV_SP
Cond Level Output	0 to 5	V	LEV_OUTV
Cond Level Error	0 to 5	V	LEV_ERR
Cond Level Integral	0 to 100		LEV_INT
Cond Level Output	0 to 100	%	LEV_OUTP
Cond Level Range	0 to 5	V	LEV_RANG
Cond EXV Max Movement	0 to 100	%	CEXV_MAX

NOTE: All variables with CAPITAL LETTER point names are available for CCN read operation; those with (**) shall support write operations for all CCN devices.

Table 3 — ICVC Display Data (cont)

EXAMPLE 8 — POWER DISPLAY SCREEN

To access this display from the ICVC default screen:

1. Press **MENU**.
2. Press **STATUS**.
3. Scroll down to highlight **POWER**.
4. Press **SELECT**.

DESCRIPTION	STATUS	UNITS	POINT
Percent Line Current	0 to 999	%	LNAMPS_P
Average Line Current	0 to 99999	AMPS	LNAMPS_A
Percent Line Voltage	0 to 999	%	LN_VOLT_P
Average Line Voltage	0 to 99999	VOLTS	LN_VOLT_A
Line Power Factor	0.0 to 2.0		LINE_PF
Line Kilowatts	0 to 99999	KW	LINE_KW
Percent Line Kilowatts	0 to 99999	%	LINEKW_P
Percent Load Current	0 to 99999	%	LDAMPS_P
Average Load Current	0 to 99999	AMPS	LDAMPS_A
Motor Power Factor	0.0 to 2.0		MOTOR_PF
Motor Kilowatts	0 to 99999	KW	MOTOR_KW
Percent Motor Kilowatts	0 to 99999	%	MOTORKWP
Motor Kilowatt-Hours	0 to 99999	KWH	MOTORKWH
Demand Kilowatts	0 to 99999	KW	DEM_KW
Line Current Phase 1 (R)	0 to 99999	AMPS	LN_AMPS1
Line Current Phase 2 (S)	0 to 99999	AMPS	LN_AMPS2
Line Current Phase 3 (T)	0 to 99999	AMPS	LN_AMPS3
Load Current Phase 1 (U)	0 to 99999	AMPS	LD_AMPS1
Load Current Phase 2 (V)	0 to 99999	AMPS	LD_AMPS2
Load Current Phase 3 (W)	0 to 99999	AMPS	LD_AMPS3
Line Voltage Phase 1 (RS)	0 to 99999	VOLTS	LN_VOLT1
Line Voltage Phase 2 (ST)	0 to 99999	VOLTS	LN_VOLT2
Line Voltage Phase 3 (TR)	0 to 99999	VOLTS	LN_VOLT3
Ground Fault Current	0 to 999	AMPS	GF_AMPS
Line Frequency	0 to 99	Hz	LINEFREQ
Rectifier Overload	0 to 100	%	RECT_OV
Inverter Overload	0 to 100	%	INV_OV
Motor Overload	0 to 100	%	MOTOR_OV
Line Current Imbalance	0 to 100	%	LN_IMB_I
Motor Current Imbalance	0 to 100	%	MT_IMB_I
Line Voltage Imbalance	0 to 100	%	LN_IMB_V
Line Active Current	0 to 99999	AMPS	AMPS_ACT
Line Reactive Current	0 to 99999	AMPS	AMPS_RE
Line Active Voltage	0 to 99999	VOLTS	VOLT_ACT
Line Reactive Voltage	0 to 99999	VOLTS	VOLT_RE
DC Bus Voltage Reference	0 to 99999	VOLTS	BUS_REF
DC Bus Voltage	0 to 99999	VOLTS	BUS_VOLT
Flux Current	0 to 99999	AMPS	FLUXAMPS
Torque Current	0 to 99999	AMPS	TORQAMPS
Inverter Temperature	0 to 300	°F (°C)	INV_TEMP
Rectifier Temperature	0 to 300	°F (°C)	REC_TEMP
VFD Dewpoint	0.0 to 300.0	°F (°C)	VFDDEWPT
VFD Enclosure Temperature	0 to 300	°F (°C)	VFD_ENCL
VFD Cold Plate Temperature	0 to 300	°F (°C)	CP_TEMP
Humidity Sensor Input	0.0 to 5.0	VOLTS	HUMID_SR
Relative Humidity	0 to 100	%	HUMIDITY
VFD Coolant Flow	0 to 100	%	VFD_FOUT
Actual VFD Speed	0 to 100	%	VFD_ACT
Comp Motor RPM	0 to 300000	rpm	CPR_RPM
Comp Motor Frequency	0 to 10000	Hz	VFD_FREQ
Comp Maximum Speed	0 to 101	Hz	MAXSPEED
Comp Minimum Speed	0 to 100	%	MINSPEED

NOTE: All variables with CAPITAL LETTER point names are available for CCN read operation.

Table 3 — ICVC Display Data (cont)

EXAMPLE 9 — VFD_STAT DISPLAY SCREEN

To access this display from the **ICVC default** screen:

1. Press **MENU**.
2. Press **STATUS**.
3. Scroll down to highlight **VFD_STAT**.
4. Press **SELECT**.

DESCRIPTION	STATUS	UNITS	POINT
VFD Fault Code	0 to 272		VFD_FLT
Single Cycle Dropout	0/1	NORMAL/ALARM	CYCLE_1
Line Current Imbalance	0/1	NORMAL/ALARM	LINEIM_I
Line Voltage Imbalance	0/1	NORMAL/ALARM	LINEIM_V
Line Phase Reversal	0/1	NORMAL/ALARM	PH_REV
High Line Voltage	0/1	NORMAL/ALARM	HI_VOLT
Low Line Voltage	0/1	NORMAL/ALARM	LOW_VOLT
High DC Bus Voltage	0/1	NORMAL/ALARM	HI_DCBUS
Low DC Bus Voltage	0/1	NORMAL/ALARM	LO_DCBUS
Motor Current Imbalance	0/1	NORMAL/ALARM	MOTIM_I
Motor Overload	0/1	NORMAL/ALARM	MOTOR_OV
Rectifier Overcurrent	0/1	NORMAL/ALARM	RECT_OI
Rectifier Overtemp	0/1	NORMAL/ALARM	RECT_OT
Rectifier Power Fault	0/1	NORMAL/ALARM	RECT_PU
Inverter Overcurrent	0/1	NORMAL/ALARM	INV_OI
Inverter Overtemp	0/1	NORMAL/ALARM	INV_OT
Inverter Power Fault	0/1	NORMAL/ALARM	INV_PU
Ground Fault	0/1	NORMAL/ALARM	GRND_FLT
Frequency Fault	0/1	NORMAL/ALARM	FREQFLT
VFD Power on Reset	0/1	NORMAL/ALARM	VFD_POR
Start Complete	0/1	FALSE/TRUE	START_OK
Stop Complete	0/1	FALSE/TRUE	STOP_OK
Condenser High Pressure	0/1	NORMAL/ALARM	PRS_TRIP
Motor Amps Not Sensed	0/1	NORMAL/ALARM	NO_AMPS
Start Acceleration Fault	0/1	NORMAL/ALARM	ACCELFLT
Stop Fault	0/1	NORMAL/ALARM	AMPSTOP
VFD Start Inhibit	0/1	NORMAL/ALARM	STRT_INH
VFD Checksum Error	0/1	NORMAL/ALARM	CHEKSUM
VFD Comm Fault	0/1	NORMAL/ALARM	VFD_COMM
VFD Fault	0/1	NORMAL/ALARM	VFDFAULT
VFD Gateway Version #	0 to 255		VFG_VER
VFD Inverter Version #	0 to 1000		INV_VER
VFD Rectifier Version #	0 to 1000		REC_VER

NOTE: All variables with CAPITAL LETTER point names are available for CCN read operation.

EXAMPLE 10 — ICVC_PWD DISPLAY SCREEN

To access this display from the **ICVC default** screen:

1. Press **MENU**.
2. Press **STATUS**.
3. Scroll down to highlight **ICVC_PWD**.
4. Press **SELECT**.

DESCRIPTION	STATUS	UNITS	POINT
Disable Service Password	0/1	DS/ENABLE	PSWD_DIS
**Remote Reset Option	0/1	DS/ENABLE	RESETOPT
Reset Alarm ?	0/1	NO/YES	REMRESET
CCN Mode ?	0/1	NO/YES	REM_CCN

NOTE: The Disable Service Password parameter supports the service tool password disable access. It will only allow forcing with the service tool for a one time bypass of both the service menu and the VFD config data table. Exit from the service menu reverts to normal password operation. Those with (***) shall support write operations for ICVC only.

The Reset Alarm? and CCN mode? parameters support write operations from CCN and LEI devices when the Remote Reset Option is enabled.

Table 3 — ICVC Display Data (cont)

EXAMPLE 11 — SETPOINT DISPLAY SCREEN

To access this display from the **ICVC default** screen:

1. Press **MENU**.
2. Press **SETPOINT** (Base Demand Limit will be highlighted).
3. Press **SELECT**.

DESCRIPTION	STATUS	UNITS	POINT	DEFAULT
Base Demand Limit	40 to 100	%	dlim	100
Control Point Source				
LCL Setpoint	10 to 60 F (–12.2 to 15.6 C)	°F (°C)	lcl_sp	50.0 F (10.0 C)
ECL Setpoint	15 to 65 F (–9.4 to 18.3 C)	°F (°C)	ecl_sp	60.0 F (15.6 C)
Ice Build Setpoint	15 to 60 F (–9.4 to 15.6 C)	°F (°C)	ice_sp	40 F (4.4 C)
Tower Fan High Setpoint	55to 105 F (13 to 41 C)	°F (°C)	tfh_sp	75 F (23.9 C)

NOTE: No variables are available for CCN read operation; forcing shall not be supported on setpoint screens.

EXAMPLE 12 — CAPACITY DISPLAY SCREEN

To access this display from the **ICVC default** screen:

1. Press **MENU**.
2. Press **SERVICE**.
3. Scroll down to highlight **CONTROL ALGORITHM STATUS**.
4. Press **SELECT**.
5. Scroll down to highlight **CAPACITY**.

DESCRIPTION	STATUS	UNITS	POINT
Entering Chilled Liquid	–40 to 245	°F (°C)	ECL
Leaving Chilled Liquid	–40 to 245	°F (°C)	LCL
Capacity Control			
Control Point	10 to 65	°F (°C)	ctrlpt
Control Point Error	–99 to 99	^F (^C)	cperr
ECL Delta T	–99 to 99	^F (^C)	ecldt
ECL Reset	–99 to 99	^F (^C)	eclres
LCL Reset	–99 to 99	^F (^C)	lclres
Total Error + Resets	–99 to 99	^F (^C)	error
Cap Delta	–2 to 2	%	capdelta
VFD Delta	–2 to 2	%	vfddelta
Target VFD Speed	0 to 100	%	VFD_TRG
Actual VFD Speed	0 to 110	%	VFD_ACT
Comp Motor RPM	0 to 300000	rpm	CPR_RPM
Comp Motor Frequency	0 to 10000	Hz	VFD_FREQ
Comp Maximum Speed	0 to 101	Hz	MAXSPEED
Comp Minimum Speed	0 to 100	%	MINSPEED
VFD Speed Output	0 to 110	%	VFD_OUT
VFD Gain	0.1 to 1.5		vfd_gain
Demand Limit Inhibit	0.2 to 1	%	DEM_INH
Amps/kW Ramp	0 to 100	%	RAMP_LMT

NOTE: All variables with CAPITAL LETTER point names are available for CCN read operation; forcing shall not be supported on maintenance screens.

EXAMPLE 13 — OVERRIDE DISPLAY SCREEN

To access this display from the **ICVC default** screen:

1. Press **MENU**.
2. Press **SERVICE**.
3. Scroll down to highlight **CONTROL ALGORITHM STATUS**.
4. Press **SELECT**.
5. Scroll down to highlight **OVERRIDE**.

DESCRIPTION	STATUS	UNITS	POINT
Comp Motor Winding Temp	–40 to 245	°F (°C)	MTRW
Comp Motor Temp Override	150 to 200	°F (°C)	MT_OVER
Condenser Pressure	–6.7 to 420	psi (kPa)	CRP
Cond Press Override	150 to 260	psi (kPa)	CP_OVER
Calc Evap Sat Temp	–40 to 245	°F (°C)	ERT
Evap Sat Override Temp	2 to 45	°F (°C)	ERT_OVER
Comp Discharge Temp	–40 to 245	°F (°C)	CMPD
Comp Discharge Alert	125 to 200	°F (°C)	CD_ALERT
Rectifier Temperature	0 to 300	°F (°C)	RECT_TEMP
Rectifier Temp Override	125 to 200	°F (°C)	REC_OVER
Inverter Temperature	0 to 300	°F (°C)	INV_TEMP
Inverter Temp Override	125 to 200	°F (°C)	INV_OVER
Discharge Superheat	–20 to 999	^F (^C)	SUPRHEAT
Condenser Refrig Temp	–40 to 245	°F (°C)	CRT

NOTE: All variables with CAPITAL LETTER point names are available for CCN read operation; forcing shall not be supported on maintenance screens.

Table 3 — ICVC Display Data (cont)

EXAMPLE 14 — LL_MAINT DISPLAY SCREEN

To access this display from the ICVC default screen:

1. Press **MENU**.
2. Press **SERVICE**.
3. Scroll down to highlight **CONTROL ALGORITHM STATUS**.
4. Press **SELECT**.
5. Scroll down to highlight **LL_MAINT**.

DESCRIPTION	STATUS	UNITS	POINT
Lead Lag Control	NOTE 1		
LEADLAG: Configuration	NOTE 1		leadlag
Current Mode	NOTE 2		lmode
Load Balance Option	0/1	DSABLE/ENABLE	loadbal
LAG Start Time	0 to 60	MIN	lagstart
LAG Stop Time	0 to 60	MIN	lagstop
Prestart Fault Time	0 to 60	MIN	prefit
Pulldown Time	0.0 to 30.0	MIN	pulltime
Pulldown: Delta T/Min	XX.X	^F (^C)	pull_dt
Satisfied ?	0/1	NO/YES	pull_sat
LEAD CHILLER in Control	0/1	NO/YES	leadctrl
LAG CHILLER: Mode	NOTE 3		lagmode
Run Status	NOTE 4		lagstat
Start/Stop	NOTE 5		lag_s_s
Recovery Start Request	0/1	NO/YES	lag_rec
STANDBY CHILLER: Mode	NOTE 3		stdmode
Run Status	NOTE 4		stdstat
Start/Stop	NOTE 5		std_s_s
Recovery Start Request	0/1	NO/YES	std_rec
Spare Temperature 1	-40 to 245	°F (°C)	SPARE_T1
Spare Temperature 2	-40 to 245	°F (°C)	SPARE_T2

NOTES:

1. DISABLE, LEAD, LAG, STANDBY, INVALID
2. DISABLE, LEAD, LAG, STANDBY, RECOVERY, CONFIG
3. Reset, Off, Local, CCN, Blank
4. Timeout, Ready, Recycle, Prestart, Startup, Ramping, Running, Demand, Override, Shutdown, Trippout, Pumpdown, Lockout, 'Blank'
5. Stop, Start, Retain, 'Blank'
6. All variables with CAPITAL LETTER point names are available for CCN read operation; forcing shall not be supported on maintenance screens.

Table 3 — ICVC Display Data (cont)

EXAMPLE 15 — VFD_HIST DISPLAY SCREEN

To access this display from the ICVC default screen:

1. Press **MENU**.
2. Press **SERVICE**.
3. Scroll down to highlight **CONTROL ALGORITHM STATUS**.
4. Press **SELECT**.
5. Scroll down to highlight **VFD_HIST**.

DESCRIPTION	STATUS	UNITS	POINT
VFD FAULT HISTORY			
Values At Last Fault:			
Line Current Phase 1 (R)	0 to 99999	AMPS	LNAMPS1H
Line Current Phase 2 (S)	0 to 99999	AMPS	LNAMPS2H
Line Current Phase 3 (T)	0 to 99999	AMPS	LNAMPS3H
Load Current Phase 1 (U)	0 to 99999	AMPS	LDAMPS1H
Load Current Phase 2 (V)	0 to 99999	AMPS	LDAMPS2H
Load Current Phase 3 (W)	0 to 99999	AMPS	LDAMPS3H
Line Voltage Phase 1 (RS)	0 to 99999	VOLTS	LNVOLT1H
Line Voltage Phase 2 (ST)	0 to 99999	VOLTS	LNVOLT2H
Line Voltage Phase 3 (TR)	0 to 99999	VOLTS	LNVOLT3H
Ground Fault Current	0 to 999	AMPS	GF_AMPSH
Line Frequency	0 to 99	Hz	LINEFRQH
Line Power Factor	0 to 2.0		LINE_PFH
Line Current Imbalance	0 to 100	%	LN_IMBIH
Line Voltage Imbalance	0 to 100	%	LN_IMBVH
Motor Power Factor	0 to 2.0		MOTORPFH
Motor Current Imbalance	0 to 100	%	MT_IMBIH
Motor Overload	0 to 100	%	MOTOROVH
Line Active Current	0 to 99999	AMPS	AMPSACTH
Line Reactive Current	0 to 99999	AMPS	AMPS_REH
Line Active Voltage	0 to 99999	VOLTS	VOLTACTH
Line Reactive Voltage	0 to 99999	VOLTS	VOLT_REH
DC Bus Voltage	0 to 99999	VOLTS	BUSVOLTH
DC Bus Voltage Reference	0 to 99999	VOLTS	BUS_REFH
Flux Current	0 to 99999	AMPS	FLUXAMPH
Torque Current	0 to 99999	AMPS	TORQAMPH
Inverter Temperature	0 to 300	°F (°C)	INVTEMPH
Rectifier Temperature	0 to 300	°F (°C)	RECTEMPH
VFD Dewpoint	0.0 to 300.0	°F (°C)	VFDDEWPT
VFD Enclosure Temp	0 to 300	°F (°C)	VFDENCLH
VFD Cold Plate Temp	0 to 300	°F (°C)	CP_TEMP
Actual VFD Speed	0 to 100	%	VFD_ACTH
Comp Motor RPM	0 to 300000	rpm	CPR_RPMH
Comp Motor Frequency	0 to 10000	Hz	VFDREQH
Chiller Fault State	200 to 272		VFDSTATH
VFD Fault Code	200 to 272		VFD_FLTH

NOTE: All variables with CAPITAL LETTER point names are available for CCN read operation; forcing shall not be supported on maintenance screens.

EXAMPLE 16 — LOADSHED DISPLAY SCREEN

To access this display from the ICVC default screen:

1. Press **MENU**.
2. Press **SERVICE**.
3. Scroll down to highlight **CONTROL ALGORITHM STATUS**.
4. Press **SELECT**.
5. Scroll down to highlight **LOADSHED**.

DESCRIPTION	STATUS	UNITS	POINT
LOADSHED FUNCTION			
Redline	0/1	NO/YES	REDLINE
Loadshed	0/1	NO/YES	LOADSHED
Loadshed Timer	0 to 480		LOADTIME

NOTE: All variables with CAPITAL LETTER point names are available for CCN read operation; forcing shall not be supported on maintenance screens.

Table 3 — ICVC Display Data (cont)

EXAMPLE 17 — WSMCHLRE DISPLAY SCREEN

To access this display from the ICVC default screen:

1. Press **MENU**.
2. Press **SERVICE**.
3. Scroll down to highlight **CONTROL ALGORITHM STATUS**.
4. Press **SELECT**.
5. Scroll down to highlight **WSMDEFME**.

DESCRIPTION	STATUS	UNITS	POINT
WSM Active?	0/1	NO/YES	WSMSTAT
Chilled Water Temp	0.0 to 99.9	°F (°C)	CHWTEMP
Equipment Status	0/1	OFF/ON	CHWRST
Commanded State		TEXT	CHWRENA
CHW Setpoint Reset Value	0.0 to 25.0	^F (^C)	CHWRVAL
Current CHW Set Point	0.0 to 99.9	°F (°C)	CHWSTPT

NOTE: All variables with CAPITAL LETTER point names are available for CCN read operation; forcing shall not be supported on maintenance screens.

EXAMPLE 18 — NET_OPT DISPLAY SCREEN

To access this display from the ICVC default screen:

1. Press **MENU**.
2. Press **SERVICE**.
3. Scroll down to highlight **EQUIPMENT CONFIGURATION**.
4. Press **SELECT**.
5. Scroll down to highlight **NET_OPT**.

DESCRIPTION	STATUS	UNITS	POINT	DEFAULT
Loadshed Function				
Group Number	1 to 16		ldsgprn	0
Demand Limit Decrease	0 to 60	%	ldsdlta	20
Maximum Loadshed Time	30 to 480	MIN	maxshed	120
CCN Occupancy Config:				
Schedule Number	3 to 99		occ_num	3
Broadcast Option	0 to 1	DSABLE/ENABLE	occbrcst	DSABLE
Alarm Configuration				
Re-Alarm Time	0 to 1440	MIN	retime	30
Alarm Routing	0 to 1		routing	10000000

NOTE: No variables are available for CCN read or write operation.

Table 3 — ICVC Display Data (cont)

EXAMPLE 19 — VFD_CONF DISPLAY SCREEN

To access this display from the ICVC default screen:

1. Press **[MENU]**.
2. Press **[SERVICE]**.
3. Scroll down to highlight **VFD CONFIG DATA**.
4. Press **[SELECT]**.
5. Scroll down to highlight **VFD_CONF**.

DESCRIPTION	STATUS	UNITS	POINT	DEFAULT
Motor Nameplate Voltage	380 to 480	VOLTS	motor_nv	480
Compressor 100% Speed	54 to 110 (Q,R Compressors)	Hz	comp_100	70
	54 to 140 (P Compressor)			
* Rated Line Voltage	208 to 600	VOLTS	vfd_volt	460
* Rated Line Amps	10 to 5000	AMPS	vfd_amps	200
* Rated Line Kilowatts	0 to 999999	KW	vfd_rlkw	100
*Motor Rated Load KW	0 to 999999	KW	mot_rlkw	100
*Motor Rated Load Amps	10 to 5000	AMPS	mot_rla	200
Motor Nameplate Amps	10 to 5000	AMPS	motorni	100
Motor Nameplate RPM	1500 to 3500 (Q,R Compressors)		motorpm	2672
	1500 to 3960 (P Compressor)			3750
Motor Nameplate kW	0 to 999999	KW	motorkw	100
Inverter PWM Frequency (0=4 kHz, 1=2 kHz)	0/1		pwm_freq	0
Skip Frequency 1	0 to 102	Hz	skipfrq1	102
Skip Frequency 2	0 to 102	Hz	skipfrq2	102
Skip Frequency 3	0 to 102	Hz	skipfrq3	102
Skip Frequency Band	0 to 102	Hz	skipband	0
Line Voltage % Imbalance	1 to 10	%	v_umbal	10
Line Voltage Imbal Time	1 to 10	SEC	v_time	10
Line Current % Imbalance	5 to 40	%	lineim_i	40
Line Current Imbal Time	1 to 10	SEC	lineim_t	10
Motor Current % Imbalance	5 to 40	%	motim_i	40
Motor Current Imbal Time	1 to 10	SEC	motim_t	10
Increase Ramp Time	5 to 60 (Q,R Compressors)	SEC	ramp_inc	30
	0 to 255 (P Compressor)			
Decrease Ramp Time	5 to 60 (Q,R Compressors)	SEC	ramp_dec	255
	5 to 255 (P Compressor)			30
Single Cycle Dropout	0/1	DSABLE/ENABLE	cycdrop	DSABLE

NOTE: Those parameters marked with a * shall not be downloaded to the VFD, but shall be used in other calculations and algorithms in the ICVC.

Table 3 — ICVC Display Data (cont)

EXAMPLE 20 — OPTIONS DISPLAY SCREEN

To access this display from the **ICVC default** screen:

1. Press **[MENU]**.
2. Press **[SERVICE]**.
3. Scroll down to highlight **[EQUIPMENT SERVICE]**.
4. Press **[SELECT]**.
5. Scroll down to highlight **[OPTIONS]**.

DESCRIPTION	STATUS	UNITS	POINT	DEFAULT
Auto Restart Option	0/1	DSABLE/ENABLE	astart	DSABLE
Remote Contacts Option	0/1	DSABLE/ENABLE	r_contac	DSABLE
Soft Stop Amps Threshold	40 to 100	%	softstop	100
Hot Gas Bypass				
HGBP Option	0, 1, 2	0=DSABLE 1=HGBP 2=LOW LOAD HGBP	Srg_hgbp	DSABLE
Min. Load Point (T1,P1)				
HGBP Delta T1	0.5 to 20 (0.3 to 11.1)	^F (^C)	hgbp_dt1	1.5 (0.8)
HGBP Delta P1	10 to 170 (68.9 to 1172.2)	psi (kPa)	hgbp_dp1	150 (1034.2)
Full Load Point (T2,P2)				
HGBP Delta T2	0.5 to 20 (0.3 to 11.1)	^F (^C)	hgbp_dt2	4 (2.2)
HGBP Delta P2	30 to 250 (206.9 to 1724)	psi (kPa)	hgbp_dp2	200 (1379)
HGBP Deadband	0.5 to 3 (0.3 to 1.7)	^F (^C)	hgbp_db	1 (0.6)
HGBP On Delta Speed	0.0 to 20.0	%	hgbp_on	5.0
HGBP Off Delta Speed	0.0 to 20.0	%	hgbp_off	3.0
Stall Protection				
Stall Delta % Amps	5 to 20	%	stall_a	10
Stall Time Period	7 to 10	MIN	stall_t	8
Ice Build Control				
Ice Build Option	0/1	DSABLE/ENABLE	ibopt	DSABLE
Ice Build Termination	0 to 2		ibterm	0
(0=TEMP, 1=Contact, 2=Both)				
Ice Build Recycle	0/1	DSABLE/ENABLE	ibrecyc	DSABLE
Refrigerant Leak Option	0/1	DSABLE/ENABLE	leak_en	DSABLE
PPM at 20mA	0 to 99999		ppm_20	1000
Refrig Leak Alarm PPM	0 to 99999		ppm_lim	500
Head Pressure Reference				
Delta P at 0% (4mA)	20 to 85 (138 to 586)	psi (kPa)	hdpd0	25 (172)
Delta P at 100% (20mA)	20 to 85 (138 to 586)	psi (kPa)	hdpd100	50 (345)
Minimum Output	0 to 100	%	hdpdmin%	0

NOTE: No variables are available for CCN read or write operation.

Table 3 — ICVC Display Data (cont)

EXAMPLE 21 — SETUP1 DISPLAY SCREEN

To access this display from the **ICVC default** screen:

1. Press **[MENU]**.
2. Press **[SERVICE]**.
3. Scroll down to highlight **[EQUIPMENT SERVICE]**.
4. Press **[SELECT]**.
5. Scroll down to highlight **[SETUP1]**.

DESCRIPTION	STATUS	UNITS	POINT	DEFAULT
Comp Motor Temp Override	150 to 200 (66 to 93)	°F (°C)	mt_over	200 (93)
Cond Press Override	145 to 166 (1000 to 1145)	psi (kPa)	cp_over	145 (1000)
Comp Discharge Alert	125 to 160 (52 to 71)	°F (°C)	cd_alert	140 (60)
Rectifier Temp Override	155 to 170 (68 to 77) (Q,R Compressors)	°F (°C)	rec_over	160 (71) (Q,R Compressors)
	155 to 190 (68 to 88) (P Compressor)			180 (P Compressor)
Inverter Temp Override	155 to 170 (68 to 77) (Q,R Compressors)	°F (°C)	inv_over	160 (71) (Q,R Compressors)
	155 to 190 (68 to 88) (P Compressor)			180 (P Compressor)
Chilled Medium	0/1	WATER/BRINE	medium	WATER
Chilled Liquid Deadband	0.5 to 2.0 (0.3 to 1.1)	^F (^C)	cldb	1.0 (0.6)
Evap Refrig Trippoint	2.0 to 10.0 (0.3-5.6)	°F (°C)	ert_trip	33 (0.6)
Refrig Override Delta T	2.0 to 5.0 (1.1 to 2.8) (Q,R Compressors)	^F (^C)	ref_over	5 (2.8)
	2.0 to 10.0 (1.1 to 5.6) (P Compressor)			
Evap Approach Alert	0.5 to 30.0 (0.3 to 16.6) (Q,R Compressors)	^F (^C)	evap_al	4(2.2)
	0.5 to 10.0 (0.3 to 5.6) (P Compressor)			
Cond Approach Alert	0.5 to 30 (0.3 to 16.6)	^F (^C)	cdap_al	6 (3.3)
Condenser Freeze Point	-20 to 35 (-28.9 to 1.7)	°F (°C)	cdfreeze	34 (1.1)
Flow Delta P Display	0/1	DSABLE/ENABLE	flowdisp	DSABLE
Evap Flow Delta P Cutout	0.5 to 50.0 (3.45 to 344.7)	psi (kPa)	evap_cut	5.0 (34.5)
Cond Flow Delta P Cutout	0.5 to 50.0 (3.45 to 344.7)	psi (kPa)	cond_cut	5.0 (34.5)
Oil Press Verify Time	15 to 300	SEC	oilpr_t	45
Liquid Flow Verify Time	0.5 to 5	MIN	lflow_t	5
Recycle Control				
Restart Delta T	2.0 to 10.0 (1.1 to 5.6)	^F (^C)	rcycr_dt	5 (2.8)
Shutdown Delta Speed	0.0 to 20.0 (Q,R Compressors)	%	rcycs_dv	2.0
	-10.0 to 20.0 (P Compressor)			0.5
Shutdown Delta T (P Compressor Only)	2.0 to 10 (1.1 to 5.6)	^F (^C)	rcycs_dt	5 (2.8)
Spare Alert/Alarm Enable Disable=0, Lo=1/3, Hi=2/4				
Spare Temp #1 Enable	0 to 4		sp1_en	0
Spare Temp #1 Limit	-40 to 245 (-40 to 118)	°F (°C)	sp1_lim	245 (118)
Spare Temp #2 Enable	0 to 4		sp2_en	0
Spare Temp #2 Limit	-40 to 245 (-40 to 118)	°F (°C)	sp2_lim	245 (118)

NOTE: No variables are available for CCN read or write operation; forcing shall not be supported on service screens.

Table 3 — ICVC Display Data (cont)

EXAMPLE 22 — SETUP2 DISPLAY SCREEN

To access this display from the ICVC default screen:

1. Press **[MENU]**.
2. Press **[SERVICE]**.
3. Scroll down to highlight **[EQUIPMENT SERVICE]**.
4. Press **[SELECT]**.
5. Scroll down to highlight **[SETUP2]**.

DESCRIPTION	STATUS	UNITS	POINT	DEFAULT
Capacity Control				
Proportional Inc Band, Q, R Compressors	2 to 10		vfd_inc	6.5
Proportional Inc Band, P Compressor	2 to 15		vfd_inc	12.0
Proportional Dec Band	2 to 10		vfd_dec	6.0
Proportional ECL Gain	1 to 3		vfd_ecl	2
VFD Speed Control				
VFD Gain	0.1 to 1.5		vfd_gain	0.75
VFD Minimum Speed	15 to 50	%	vfd_min	20
VFD Maximum Speed	50 to 100	%	vfd_max	100
Vaporizer Heater Mode* 0=Normal, 1=Service	0/1		vhtr_mode	0
Oil Reclaim Min Output	0 to 25	%	oilr_lim	25

*P compressor only.

NOTE: No variables are available for CCN read or write operation; forcing shall not be supported on service screens.

EXAMPLE 23 — SETUP3 DISPLAY SCREEN (P COMPRESSOR ONLY)

To access this display from the ICVC default screen:

1. Press **[MENU]**.
2. Press **[SERVICE]**.
3. Scroll down to highlight **[EQUIPMENT SERVICE]**.
4. Press **[SELECT]**.
5. Scroll down to highlight **[SETUP3]**.

DESCRIPTION	STATUS	UNITS	POINT	DEFAULT
Oil Sump and Vap. Heater Control				
Vap. Heater Turn On Speed	550 to 950	rpm	vspdon	595
Vap. Heater Turn Off Speed	600 to 2500	rpm	vspdoddf	625
Vap. Heater Turn On Lift	18 to 30 (10 to 17)	^F (^C)	vlifton	22.5 (12.5)
Vap. Heater Turn Off Lift	25 to 35 (14 to 19)	^F (^C)	vliftoff	26 (14.4)
Cond Refrig Temp Low Limit	55 to 80 (13 to 27)	°F (°C)	oilcrtlo	70 (21)
Sump Heater Turn On Speed	550 to 850	rpm	smponsp	700
Sump Heater Turn Off Speed	600 to 2500	rpm	smpoffsp	750
Sump Heater Turn On Lift	18 to 30 (10 to 17)	^F (^C)	smoponlf	22.0 (12)
Sump Heater Turn Off Delta T	20 to 60 (11 to 33)	^F (^C)	smpoffdt	40 (22)

NOTE: No variables are available for CCN read operation; forcing shall not be supported on service screens.

EXAMPLE 24 — SETUP3 DISPLAY SCREEN (Q AND R COMPRESSORS)

To access this display from the ICVC default screen:

1. Press **[MENU]**.
2. Press **[SERVICE]**.
3. Scroll down to highlight **[EQUIPMENT SERVICE]**.
4. Press **[SELECT]**.
5. Scroll down to highlight **[SETUP3]**.

DESCRIPTION	STATUS	UNITS	POINT	DEFAULT
Compressor Type 1=TR, 2=TQ, 3=Other	1-3		cmp_type	0
VAPORIZER HEATER CONTROL				
Vaporizer Heater Mode	0-1		vhtr_mode	0
Turn On Speed	550-650	RPM		595
Turn Off Speed	600-2500	RPM	oilr_lim	625
Turn On Lift	18-30	%		22.5
Turn Off Lift	25-35	%		26

NOTE: No variables are available for CCN read operation; forcing shall not be supported on service screens.

Table 3 — ICVC Display Data (cont)

EXAMPLE 25 — SETUP4 DISPLAY SCREEN (P COMPRESSOR ONLY)

To access this display from the ICVC default screen:

1. Press **[MENU]**.
2. Press **[SERVICE]**.
3. Scroll down to highlight **[EQUIPMENT SERVICE]**.
4. Press **[SELECT]**.
5. Scroll down to highlight **[SETUP4]**.

DESCRIPTION	STATUS	UNITS	POINT	DEFAULT
Economizer Control				
Economizer Option	0/1	DSABLE/ENABLE	econ_opt	DSABLE
Econ Activate Speed	20 to 100	%	econ_act	50
Econ Activate Deadband	0 to 20	%	econ_db	10
Econ EXV Max Movement	0.5 to 5.0	%	eevx_mov	3.0
Superheat Setpoint	0.0 to 20.0 (0.0 to 11.1)	^F (^C)	super_sp	6.0 (3.3)
Econ Proportional Gain	0.1 to 2.0		econ_kp	0.1
Econ PID Calc Time	10 to 120	SEC	pid_time	25

NOTE: No variables are available for CCN read operation; forcing shall not be supported on service screens.

EXAMPLE 26 — SETUP5 DISPLAY SCREEN (P COMPRESSOR ONLY)

To access this display from the ICVC default screen:

1. Press **[MENU]**.
2. Press **[SERVICE]**.
3. Scroll down to highlight **[EQUIPMENT SERVICE]**.
4. Press **[SELECT]**.
5. Scroll down to highlight **[SETUP5]**.

DESCRIPTION	STATUS	UNITS	POINT	DEFAULT
Condenser Level Control				
Cond EXV Max Movement	0.5 to 10.0	%	cexv_mov	10
Cond EXV Min Position	15 to 60	%	cexv_min	30
Cond EXV Start Position	70 to 100	%	cexv_str	100
Disch Superheat Limit	2 to 10 (1.1 to 5.6)	^F (^C)	dshft	6 (3.3)
Cooler Approach Limit	1.5 to 20 (0.8 to 11.1)	^F (^C)	caft	2.5 (1.4)
Start Delay	0 to 255	SEC	strt_del	120
Freeze Margin at Start	0 to 10 (0 to 5.5)	^F (^C)	fmstrt	3 (1.7)
Cond Loop Timer	5 to 10	SEC	cond_tim	5
Cond Level Setpoint	0.5 to 4.8	V	levsetpt	3.0
Disch Sup Ht Corr Factor	0 to 1	%	dshft_f	0.01
Evap App Corr Factor	0 to 2	%	caft_f	0.5
Fine Tune Enabled?	Y/N		ft_yn	Y
Fine Tune Threshold	0.1 to 1	%	ft_thres	0.2
Cond Level Deadband	0.00 to 1	V	cond_db	0.4
Anti Winding Min	15 to 60	%	aw_min	30
Cond Level Prop Gain	0.2 to 5.0		cond_kp	3
Cond Level Int Gain	0.0 to 5.0		cond_ki	0.04
Cond Level Int Clamp	0.5 to 3	%	levclamp	1.5
Cond Level Low Limit	0.5 to 4.8	V	cond_lov	1.6
Cond Level High Limit	0.5 to 4.8	V	cond_hiv	3.2
Feed Forward Threshold	0.0 to 5.0		ff_thrs	1.0
Feed Forward Gain	0.0 to 30		ff_gain	0
Evap Approach Reset Gain	0.0 to 15		app_res	10

NOTE: No variables are available for CCN read operation; forcing shall not be supported on service screens.

Table 3 — ICVC Display Data (cont)

EXAMPLE 27 — LEADLAG DISPLAY SCREEN

To access this display from the **ICVC default** screen:

1. Press **[MENU]**.
2. Press **[SERVICE]**.
3. Scroll down to highlight **[EQUIPMENT SERVICE]**.
4. Press **[SELECT]**.
5. Scroll down to highlight **[LEADLAG]**.

DESCRIPTION	STATUS	UNITS	POINT	DEFAULT
Lead Lag Control				
LEAD/LAG Configuration	0 to 3		leadlag	0
DSABLE=0, Lead=1				
LAG=2, STANDBY=3				
Load Balance Option	0/1	DSABLE/ENABLE	loadbal	DSABLE
Common Sensor Option	0/1	DSABLE/ENABLE	commsens	DSABLE
LAG % Capacity	25 to 75	%	lag_per	50
LAG Address	1 to 236		lag_add	92
LAG START Timer	2 to 60	MIN	lagstart	10
LAG STOP Timer	2 to 60	MIN	lagstop	10
PRESTART FAULT Timer	2 to 30	MIN	prefit	5
PULLDOWN Timer	1 to 30	MIN	pulldown	2
STANDBY Chiller Option	0/1	DSABLE/ENABLE	stnd_opt	DSABLE
STANDBY % Capacity	25 to 75	%	stnd_per	50
STANDBY Address	1 to 236		stnd_add	93

NOTE: No variables are available for CCN read or write operation.

EXAMPLE 28 — RAMP_DEM DISPLAY SCREEN

To access this display from the **ICVC default** screen:

1. Press **[MENU]**.
2. Press **[SERVICE]**.
3. Scroll down to highlight **[EQUIPMENT SERVICE]**.
4. Press **[SELECT]**.
5. Scroll down to highlight **[RAMP_DEM]**.

DESCRIPTION	STATUS	UNITS	POINT	DEFAULT
Pulldown Ramp Type:	0/1		ramp_opt	1
Select: Temp=0, KW=1				
Demand Limit and kW Ramp				
Demand Limit Source	0/1		dem_src	0
Select: Amps=0, kW=1				
Amps or kW Ramp %/Min	5 to 20		kw_ramp	10
Demand Limit Prop Band	3 to 15	%	dem_app	10
Demand Limit At 20 mA	40 to 100	%	dem_20ma	40
20 mA Demand Limit Opt	0/1	DSABLE/ENABLE	dem_sel	DSABLE
VFD Overload Decrease	25 to 50	%	vfd_dec	30
VFD Overload Delta	3 to 15	%	vfd_delt	5
Demand Watts Interval	5 to 60	MIN	dw_int	15

NOTE: No variables are available for CCN read or write operation.

EXAMPLE 29 — TEMP_CTL DISPLAY SCREEN

To access this display from the **ICVC default** screen:

1. Press **[MENU]**.
2. Press **[SERVICE]**.
3. Scroll down to highlight **[EQUIPMENT SERVICE]**.
4. Press **[SELECT]**.
5. Scroll down to highlight **[TEMP_CTL]**.

DESCRIPTION	STATUS	UNITS	POINT	DEFAULT
Control Point Source				
ECL Control Option	0/1	DSABLE/ENABLE	ecl_opt	DSABLE
Temp Pulldown Ramp/Min	2 to 10 (1.1 to 5.6)	^F (^C)	tmp_ramp	3 (1.7)
Temperature Reset				
RESET TYPE 1				
Degrees Reset At 20 mA	-30 to 30 (-17 to 17)	^F (^C)	deg_20ma	10 (6)
RESET TYPE 2				
Remote Temp -> No Reset	-40 to 245 (-40 to 118)	°F (°C)	res_rt1	85 (29)
Remote Temp -> Full Reset	-40 to 245 (-40 to 118)	°F (°C)	res_rt2	65 (18)
Degrees Reset	-30 to 30 (-17 to 17)	^F (^C)	deg_rt	10 (6)
RESET TYPE 3				
CHL Delta T -> No Reset	0 to 15 (0 to 8)	^F (^C)	restd_1	10 (6)
CHL Delta T -> Full Reset	0-15 (0 to 8)	^F (^C)	restd_2	0 (0)
Degrees Reset	-30 to 30 (-17 to 17)	^F (^C)	deg_res	5 (3)
Enable Reset Type	0 to 3		res_sel	0

PIC III System Functions

NOTE: Words not part of paragraph headings and printed in all capital letters can be viewed on the ICVC (e.g., LOCAL, CCN, RUNNING, ALARM, etc.) Words printed in both all capital letters and italics can also be viewed on the ICVC and are parameters (*CONTROL MODE ADDED EXAMPLES*, etc.) with associated values (e.g., modes, temperatures, pressures, percentages, on, off, enable, disable, etc.). Words printed in all capital letters and in a box represent softkeys on the ICVC (e.g., **ENTER** and **EXIT**). See Table 3 for examples of the type of information that can appear on the ICVC screens. Figures 24-30 give an overview of ICVC operations and menus. The sequence of screens that should be selected to view any parameter in the ICVC can be found in Appendix A.

CAPACITY CONTROL — The PIC III control system controls the chiller capacity by changing the compressor speed in response to chilled liquid temperature deviation away from the *CONTROL POINT*. The *CONTROL POINT* may be changed by a CCN network device or is calculated by the PIC III control adding any active chilled liquid reset to the *ECL* or *LCL SET POINT*. The *CONTROL POINT* may be viewed or overridden from the MAINSTAT screen. See Fig. 27.

Changes to the chiller capacity and system overrides are achieved through the *VFD SPEED OUTPUT*.

The *VFD SPEED OUTPUT* is controlled by varying the output from 0 to 100%. The *TARGET VFD SPEED* is forcible and allows the operator manual control of the *VFD SPEED OUTPUT*. The *TARGET VFD SPEED* will be allowed to change every five seconds unless *TARGET VFD SPEED* is forced.

The *TARGET VFD SPEED* is controlled between the *VFD MINIMUM SPEED* and *VFD MAXIMUM SPEED* (refer to SETUP2 screen) based on the Capacity Control algorithm. The PIC III controls monitor the compressor oil properties and set a *COMP MINIMUM SPEED* to ensure sufficient compressor bearing lubrication under all operating conditions. The *TARGET VFD SPEED* shall not be allowed to be forced below the *COMP MINIMUM SPEED*. A summary of all capacity control conditions and responses is shown in Table 4.

Table 4 — Capacity Control Conditions

CAPACITY DELTA	VFD SPEED CONTROL	VFD SPEED CHANGE
INCREASE	TARGET VFD FORCED	TARGET VFD = Forced Value
	—	TARGET VFD = TARGET VFD + (VFD Delta x FD Gain)
	VFD SPEED = MAX	No Change
DECREASE	TARGET VFD FORCED	TARGET VFD = Forced Value
	—	TARGET VFD = TARGET VFD + (VFD Delta x VFD Gain)
	VFD SPEED = MIN.	No Change

Changes to the *TARGET VFD SPEED* are implemented by the following methods:

FORCED — The *TARGET VFD SPEED* can be forced from the ICVC. The *TARGET VFD SPEED* is set to the forced value and remains there until the force is removed or the chiller is shut down. The forced value is limited between the *VFD MINIMUM SPEED* and *VFD MAXIMUM SPEED*.

NORMAL CONDITIONS — The VFD speed changes are based on the calculated change in *VFD DELTA* multiplied by the *VFD GAIN*. *VFD DELTA* is displayed in the COMPRESS screen. The *VFD GAIN* increases or decreases the commanded

VFD speed change with respect to the *VFD DELTA* calculated by the ICVC.

CAPACITY INCREASE — If the *TARGET VFD SPEED* is less than the *VFD MAXIMUM SPEED*, the *TARGET VFD SPEED* is increased by the *VFD DELTA* times the *VFD GAIN*.

CAPACITY DECREASE — If the *TARGET VFD SPEED* is greater than the *VFD MINIMUM SPEED*, the *TARGET VFD SPEED* is decreased by the *VFD DELTA* times the *VFD GAIN*.

- *VFD DELTA* less than 0.2% will not cause the *VFD SPEED OUTPUT* to increase or decrease.
- If the Capacity Decrease is in effect due to an override then the *VFD SPEED OUTPUT* decreases at a rate of 2.0% per 5 seconds until the decrease condition is satisfied. This will occur regardless of *VFD DELTA* value.
- A VFD SPEED OUT OF RANGE fault will be declared if the *ACTUAL VFD SPEED* exceeds the *VFD SPEED OUTPUT* $\pm 10\%$ for 75 seconds when the chiller is running.
- A COMP MIN SPEED LIMITED RUN CAPACITY OVERRIDE alert will be declared when the *TARGET VFD SPEED* is being limited by the *COMPRESSOR MINIMUM SPEED*.

ECL CONTROL OPTION — If this option is enabled, the PIC III modulates the compressor speed in response to the entering chilled liquid temperature instead of the *LEAVING CHILLED LIQUID* temperature. The *ECL CONTROL OPTION* may be viewed on the TEMP_CTL screen, which is accessed from the EQUIPMENT SERVICE screen.

CHILLED LIQUID DEADBAND — This is the tolerance range on the chilled liquid/brine temperature control point. If the liquid temperature goes outside the *CHILLED LIQUID DEADBAND*, the PIC III increases or decreases compressor speed until the temperature is within tolerance. The PIC III controls may be configured with a 0.5 to 2 F (0.3 to 1.1 C) deadband. *CHILLED LIQUID DEADBAND* may be viewed or modified on the SETUP1 screen, which is accessed from the EQUIPMENT SERVICE table.

Example: A 1° F (0.6° C) *CHILLED LIQUID DEADBAND* setting controls the liquid temperature within $\pm 0.5^\circ$ F (0.3° C) of the *CONTROL POINT*. This may cause frequent changes in compressor speed if the cooling load fluctuates frequently. A value of 1° F (0.6° C) is the default setting.

PROPORTIONAL BANDS AND PROPORTIONAL GAIN — The PIC III uses the *PROPORTIONAL INC (Increase) BAND*, *PROPORTIONAL DEC (Decrease) BAND*, and the *PROPORTIONAL ECL (Entering Chilled Liquid) GAIN* to determine how fast or slow to respond. Proportional band is the rate at which the compressor speed is changed in proportion to how far the chilled liquid/brine temperature is from the *CONTROL POINT*. Proportional gain determines how quickly the VFD reacts to how quickly the temperature is deviating from the *CONTROL POINT*. The proportional bands and proportional gain may be viewed or modified from the SETUP2 screen, which is accessed from the EQUIPMENT SERVICE table.

The Proportional Band — The PIC III controls can be configured to respond differently to temperature deviations above the control point and to temperature deviations below the control point.

The PIC III control's response to temperatures above the control point is affected by the *PROPORTIONAL INC BAND*. This parameter will slow or quicken the rate at which the compressor speed is changed in response to chilled liquid/brine temperatures above the control point plus $\frac{1}{2}$ times the *CHILLED LIQUID DEADBAND*. The *PROPORTIONAL INC BAND* can be adjusted from a setting of 2 to 10; the default setting is 6.5. A smaller value of *PROPORTIONAL INC*

BAND will increase the rate at which the compressor speed is increased.

The response below the control point is called the *PROPORTIONAL DEC BAND*. This parameter will slow or quicken the rate at which the compressor speed is changed in response to chilled liquid temperatures below the *CONTROL POINT* minus $\frac{1}{2}$ times the *CHILLED LIQUID DEAD BAND*. The *PROPORTIONAL DEC BAND* can be adjusted on the ICVC from a setting of 2 to 10. The default setting is 6.0. A smaller value of *PROPORTIONAL DEC BAND* will increase the rate at which the compressor speed is decreased.

The *PROPORTIONAL ECL GAIN* changes the amount the compressor speed is changed each time the PIC III controls command an adjustment. The *PROPORTIONAL ECL GAIN* can be adjusted from 1 to 3. A larger value of *PROPORTIONAL ECL GAIN* will increase the amount the compressor speed changes each time the controls call for a change.

DEMAND LIMITING — The PIC III control module responds to the *ACTIVE DEMAND LIMIT* set point by limiting the amps or kilowatts consumed by the chiller. It compares the *ACTIVE DEMAND LIMIT* set point to the *DEMAND LIMIT SOURCE* (either the actual *AVERAGE LINE CURRENT* or the actual *MOTOR KW*), depending on how the control is configured. *DEMAND LIMIT SOURCE* is on the RAMP_DEM screen. The default *DEMAND LIMIT SOURCE* is the compressor motor amps.

CHILLER TIMERS — The PIC III control module maintains 2 runtime clocks, known as *COMPRESSOR ONTIME* and *SERVICE ONTIME*. *COMPRESSOR ONTIME* indicates the total life-time compressor run hours. This timer can register up to 500,000 hours before the clock turns back to zero. The *SERVICE ONTIME* is a resettable timer that can be used to indicate the hours since the last service visit or any other event. The time can be changed from the ICVC to whatever value is desired. The *SERVICE ONTIME* timer can register up to 32,767 hours before it rolls over to zero.

The chiller also maintains a start-to-start timer and a stop-to-start timer. These timers limit how soon the chiller can be started. *START INHIBIT TIMER* is displayed on the MAIN-STAT screen. See the Start-Up/Shutdown/Recycle Sequence section, page 60, for more information on this topic.

OCCUPANCY SCHEDULE — The chiller schedule, described in the Time Schedule Operation section (page 28), determines when the chiller can run. Each schedule consists of from 1 to 8 occupied or unoccupied time periods, set by the operator. The chiller can be started and run during an occupied time period (when YES is displayed next to *OCCUPIED?* on the MAINSTAT display screen). It cannot be started or run during an unoccupied time period (when NO is displayed next to *OCCUPIED?* on the MAINSTAT display screen). These time periods can be set for each day of the week and for holidays. The day begins with 0000 hours and ends with 2400 hours. When any occupancy schedule is in a time period when the chiller is allowed to run, the parameter *OCCUPIED?* is YES.

These schedules can be set up to follow a building's occupancy schedule, or can be set to be occupied 100% of the time, if the operator wishes. In this case, the chiller is normally started and stopped manually using the CCN, LOCAL, and STOP buttons. The schedules also can be bypassed by forcing the *CHILLER START/STOP* parameter on the MAINSTAT screen to START. For more information on forced starts, see Local Start-Up, page 60.

The schedules also can be overridden to keep the chiller in an occupied state for up to 4 hours, on a one time basis. See the Time Schedule Operation section, page 28.

Figure 29 shows a schedule for a typical office building with a 3-hour, off-peak, cool-down period from midnight to 3 a.m., following a weekend shutdown. Holiday periods are in

an unoccupied state 24 hours per day. The building operates Monday through Friday, 7:00 a.m. to 6:00 p.m., and Saturdays from 6:00 a.m. to 1:00 p.m. This schedule also includes the Monday midnight to 3:00 a.m. weekend cool-down schedule.

NOTE: This schedule is for illustration only and is not intended to be a recommended schedule for chiller operation.

Whenever the chiller is in the LOCAL mode, it uses Occupancy Schedule 01 (OCCPC01S). The chiller uses Occupancy Schedule 02 (OCCPC02S) when it is in ICE BUILD mode. When the chiller is in CCN mode, it uses Occupancy Schedule 03 (OCCPC03S).

The *CCN SCHEDULE NUMBER* is configured on the NET OPT display screen, accessed from the EQUIPMENT CONFIGURATION table. See Table 3, Example 18. *SCHEDULE NUMBER* can be changed to any value from 03 to 99. If this number is changed on the NET OPT screen, the operator must go to the ATTACH TO NETWORK DEVICE screen to upload the new number into the SCHEDULE screen. See Fig. 29.

Safety Controls — The PIC III control system monitors all safety control inputs and, if required, shuts down the chiller or limits the compressor speed to protect the chiller from possible damage from any of the following conditions:

- high motor winding temperature
- high discharge temperature
- low oil pressure
- low evaporator refrigerant temperature
- condenser high pressure or low pressure
- inadequate liquid/brine cooler and condenser flow
- high, low, or loss of voltage
- ground fault
- voltage imbalance
- current imbalance
- excessive motor acceleration time
- lack of motor current signal
- excessive motor amps
- motor stall
- temperature sensor and transducer faults
- VFD power faults
- VFD over temperature
- humidity surrounding the VFD coldplate
- reverse compressor rotation
- incorrect condenser level (for EXV controlled units)
- economizer pressure out of range (for EXV controlled units)
- economizer temperature out of range (for EXV controlled units)

VFD faults or protective devices within the VFD can shut down the chiller.

⚠ CAUTION

If compressor motor overload or a motor ground fault occurs, check the motor for grounded or open phases before attempting a restart to avoid damage to the equipment.

If the PIC III control initiates a safety shutdown, it displays the reason for the shutdown (the fault code) on the ICVC display screen along with a primary and secondary message, and blinks the alarm light on the control center. The alarm is stored in memory and can be viewed on the ALARM HISTORY and VFD_HIST screens on the ICVC, along with a message for troubleshooting. If the safety shutdown was also initiated by a fault detected in the VFD, the conditions at the time of the fault will be stored in VFD_HIST.

To give more precise information or warnings on the chiller's operating condition, the operator can define alert limits on various monitored inputs in the SETUP1 screen. Safety

contact and alert limits are defined in Table 5. Alarm and alert messages are listed in the Troubleshooting Guide section, page 100.

Shunt Trip — The function of the shunt trip on the PIC III control module is to act as a safety trip. The shunt trip is wired from the standard I/O board to a shunt trip-equipped VFD circuit breaker. If the PIC III module tries to shut down the compressor using a normal shutdown procedure but is unsuccessful for 20 seconds, the shunt trip output is energized and causes the circuit breaker to trip off. The ground fault trip also will energize the shunt trip to trip the circuit breaker. Protective devices in the VFD can also energize the shunt trip. The shunt trip feature can be tested using the Control Test feature in the DIS-CRETE OUTPUTS CONTROL TEST screen. Reset the circuit breaker immediately after performing this test.

Default Screen Freeze — When the chiller is in an alarm state, the default ICVC display “freezes,” that is, it stops updating. The first line of the ICVC default screen displays a primary alarm message; the second line displays a secondary alarm message.

The ICVC default screen freezes to enable the operator to see the conditions of the chiller *at the time of the alarm*. If the value in alarm is one normally displayed on the default screen, the value flashes between normal and reverse contrast. The ICVC default screen remains frozen until the condition that caused the alarm is remedied by the operator.

Knowledge of the operating state of the chiller at the time an alarm occurs is useful when troubleshooting. Additional chiller information can be viewed on the status screens and the VFD_HIST screen. Troubleshooting information is recorded in the ALARM HISTORY table, which can be accessed from the SERVICE menu.

To determine what caused the alarm, the operator should read both the primary and secondary default screen messages, as well as the alarm history. The primary message indicates the most recent alarm condition. The secondary message gives more detail on the alarm condition. Since there may be more than one alarm condition, another alarm message may appear after the first condition is cleared. Check the ALARM HISTORY screen for additional help in determining the reasons for the alarms. Once all existing alarms are cleared (by pressing the **RESET** softkey), the default ICVC display returns to normal operation.

Ramp Loading — The ramp loading feature controls the rate at which the compressor loads up. This control can prevent the compressor from loading up too fast during the short period of time when the chiller is started and the chilled liquid loop has to be brought down to the *CONTROL POINT*. This helps reduce electrical demand charges by slowly bringing the chilled liquid to the *CONTROL POINT*.

The PIC III control system provides two methods of ramp loading. Ramp loading can be based on chilled liquid temperature or on motor load. The method of ramp loading is selected from the RAMP_DEM screen.

1. **Temperature ramp loading** (*TEMP PULLDOWN DEG/MIN*) limits the degrees per minute rate at which either the leaving chilled liquid or the entering chilled liquid temperature decreases. This rate is configured by the operator on the TEMP_CTL screen. The lowest temperature ramp rate will be used if chiller power has been off for 3 hours or more (even if the motor kilowatts ramp loading is selected as the ramp loading method).
2. **Motor load ramp loading** (*AMPS OR KW RAMP %/MIN*) limits the percent per minute rate at which the compressor motor current or compressor motor load increases. The *AMPS OR KW RAMP %/MIN* rate is

configured by the operator on the RAMP_DEM screen in amps or kilowatts.

If kilowatts is selected for the *DEMAND LIMIT SOURCE*, the *MOTOR RATED LOAD KILOWATTS* must be entered (information found on the machine Electrical Data Nameplate) in the VFD_CONF screen.

The *TEMP PULLDOWN DEG/MIN* may be viewed or modified on the TEMP_CTL screen which is accessed from the EQUIPMENT SERVICE screen. *PULLDOWN RAMP TYPE*, *DEMAND LIMIT SOURCE*, and *MOTOR KW RAMP %/MIN* may be viewed or modified on the RAMP_DEM screen.

Capacity Override (Table 6) — Adjustable capacity overrides are available to prevent the chiller from exceeding some limits and going into an alarm state. Alert messages 120 through 127 are displayed on the ICVC when capacity overrides are in effect. Capacity overrides can prevent some safety shutdowns caused by exceeding the refrigerant low temperature safety limit, motor high temperature safety limit, and condenser high pressure limit, high VFD inverter rectifier temperature limit, and high VFD inverter temperature limit.

Compressor Minimum Speed Override — This capacity override increases compressor speed if oil viscosity falls below acceptable levels or if conditions exist that will prevent sufficient refrigerant cooling to the VFD or motor. This override is not configurable, it is the only override that will increase chiller capacity to avoid a safety shutdown. Compressor minimum speed override is most likely to happen at evaporator temperatures of 50 degrees or more, combined with low speed, low lift, and less than 25% tons.

The PIC III controls regulate the minimum allowable compressor speed based on oil sump temperature and pressure and on compressor head. The compressor bearings require higher oil viscosity when operating at low speed than they do when operating at high speeds. The controls increase compressor speed when the oil viscosity is too low to operate the compressor at the lower speed. The low compressor speed override is also enabled at low loads with high condensing pressure.

Vaporizer Temperature Control COMPRESSOR ON — The vaporizer temperature control is regulated by the PIC III using the vaporizer heater relay and a flexible surface heater that is attached to the bottom of the vaporizer. The vaporizer heater relay is energized whenever the compressor is at low speed and requires additional heat to maintain a sufficient vaporizer temperature. The vaporizer heater is turned off when the additional heat is no longer required. The vaporizer heater is not energized when the chiller is not running. The vaporizer heater also uses the values configured in the SET-UP3 table for *TURN ON SPEED* and *TURN ON LIFT*, *TURN OFF SPEED* and *TURN OFF LIFT* to allow the service technician to adjust the heater control based on either compressor speed or the lift across the cooler and condenser.

Oil Sump Temperature Control COMPRESSOR OFF — The *OIL SUMP TEMP* is regulated by the PIC III control module using the (1 C) oil heater relay and an immersion heater in the oil sump. The oil heater relay is energized whenever the chiller compressor is off, and the *OIL SUMP TEMP* is less than 140 F (60 C) or whenever the *OIL SUMP TEMP* is less than the *CALC EVAP SAT TEMP* plus 53 F (29.4 C). The oil heater is then turned off when the *OIL SUMP TEMP* is:

1. More than 152 F (66.7 C) or
2. The *OIL SUMP TEMP* is more than 142 F (61.1 C) and also warmer than the *CALC EVAP SAT TEMP* plus 55 F (30.6 C).

Table 5 — Protective Safety Limits and Control Settings

MONITORED PARAMETER	ALARM OR ALERT STATE	LIMIT	COMMENTS
Temperature Sensors Out of Range	260-273 140,141	-40 deg F > Temperature > 245 deg F for 3 seconds	Preset Alarm. See Temperature vs. Resistance/Voltage Drop in Tables 10 and 11
Pressure Transducers Out of Range	262-273	0.06 > Voltage Ratio > 0.98 for 3 seconds	Preset Alarm Voltage Ratio = Input Voltage / Voltage Reference (5 Volts)
High Compressor Discharge Temperature	231	COMP DISCHARGE TEMP > 180 deg F (82 deg C)	Preset Alarm, Configure DISCH TEMP ALERT in SETUP1 screen
	162	COMP DISCHARGE TEMP > COMP DISCHARGE ALERT	Configure COMP DISCH ALERT in SETUP1 screen
	103	COMP DISCHARGE TEMP > COMP DISCHARGE ALERT - 10 deg F (5.6 deg C)	Prestart Alert, Configure COMP DISCHARGE ALERT in SETUP1 screen
High Motor Temperature	233	COMP MOTOR WINDING TEMP > 244 deg F (118 deg C) or < -5 deg F (-21 deg C) — Open Circuit	Preset Alarm
	102	COMP MOTOR WINDING TEMP > COMP MOTOR TEMP OVERRIDE - 10 deg F (5.6 deg C)	Prestart Alert, Configure COMP MOTOR TEMP OVERRIDE in SETUP1 screen
Low Evaporator Temperature (Freeze Protection)	243	Chiller in RECYCLE SHUTDOWN and CALC EVAP SAT TEMP or EVAP REFRIG LIQUID TEMP < EVAP REFRIG TRIPPOINT + 1 deg F	Preset Alarm, Configure EVAP REFRIG TRIPPOINT in SETUP1 screen
	232	For water: EVAP REFRIG LIQUID TEMP or CALC EVAP SAT TEMP < 33 deg F and EVAPORATOR APPROACH < EVAP APPROACH ALERT	Preset Alarm, Configure EVAP APPROACH ALERT in SETUP1 screen
	104	For brine: EVAP REFRIG LIQUID TEMP or CALC EVAP SAT TEMP is between 0 deg F (-17.8C) and 40 deg F (4.4 C) (brine) and EVAPORATOR APPROACH < EVAP APPROACH ALERT	Configure EVAP APPROACH ALERT and CHILLED MEDIUM in SETUP1 screen
		CALC EVAP SAT TEMP < 33 deg F + REFRIG OVERRIDE DELTA T (non-brine)	Prestart Alert, Configure REFRIG OVERRIDE DELTA T in SETUP1 screen
		CALC EVAP SAT TEMP < EVAP REFRIG TRIPPOINT (brine) + REFRIG OVERRIDE DELTA T	Prestart Alert, Configure EVAP REFRIG TRIP POINT and CHILLED MEDIUM in SETUP1 screen
Transducer Voltage Fault	239	TRANSDUCER VOLTAGE REF < 4.5 VDC	Preset Alarm
High Condenser Pressure - Control - Switch - Prestart	235	CONDENSER PRESSURE > 166 PSI	Preset Alarm
	207	High Pressure Switch Open (165 ± 5 PSIG) & VFD START = YES	Preset Alarm, Switch closes at 110 ± 7 PSIG
	106	CONDENSER PRESSURE > COND PRESS OVERRIDE - 25 PSI	Prestart Alert, Configure COND PRESS OVERRIDE in SETUP1 screen
Low Condenser Pressure (Freeze Protection)	244	Chiller in PUMPDOWN mode and CONDENSER REFRIG TEMP < CONDENSER FREEZE POINT	Preset Alarm, Configure CONDENSER FREEZE POINT in SETUP1 screen.
	154	Energizes condenser pump relay if CONDENSER REFRIG TEMP < CONDENSER FREEZE POINT. De-energizes condenser pump relay when CONDENSER REFRIG TEMP > CONDENSER FREEZE POINT + 5 deg F (2.8 deg C) and ENTERING COND LIQUID > CONDENSER FREEZE POINT	Configure CONDENSER FREEZE POINT in SETUP1 screen
Oil - Low Pressure - Low Pressure - Low Pressure - High Oil Pressure - Pressure Sensor Fault - Low Temperature	234	OIL PRESSURE DELTA P < 18 PSID after OIL PUMP = ON, OIL PRESS VERIFY TIME exceeded, and STARTUP in progress	Preset Alarm, Configure OIL PRESS VERIFY TIME in SETUP1 screen
	228	OIL PRESSURE DELTA P < 15 PSID and VFD START = TRUE	Preset Alarm, condition must persist for 55 consecutive seconds
	142	OIL PRESSURE DELTA P < 15 PSID and VFD START = TRUE	Preset Alert, condition must persist for 10 consecutive seconds
	164	Oil Pump ON and OIL PRESSURE DELTA P > 45 PSI	Preset Alert, condition must persist for 55 consecutive seconds
	227	OIL PRESSURE DELTA P > 4 PSI immediately before oil pump turned on	Preset Alarm
	105	OIL SUMP TEMP < 140 deg F and OIL SUMP TEMP < CALC EVAP SAT TEMP + 15 deg F (8.3 deg C)	Preset Prestart Alert
Line Voltage - High - High - Low - Low - Imbalance	211/145	Line voltage > limits are calculated by VFD (alert is declared if AUTORESTART is ENABLED)	Preset Alarm/Autorestart Alert
	108	PERCENT LINE VOLTAGE > 115%	Preset Prestart Alert
	212/146	Line voltage < limits calculated by VFD (alert is declared if AUTORESTART is ENABLED)	Preset Alarm/Autorestart Alert
	107	PERCENT LINE VOLTAGE < 85%	Preset Prestart Alert
	216	LINE VOLTAGE IMBALANCE > LINE VOLTAGE % IMBALANCE	Configure LINE VOLTAGE % IMBALANCE and LINE VOLT IMBALANCE TIME in VFD_CONF screen
Line Current - Dropout - Imbalance	210/144 209/143	Line Voltage on 2 Phases < 50% for 1 Cycle LINE CURRENT IMBALANCE > LINE CURRENT % IMBALANCE	Preset Alarm/Autorestart Alert Configure LINE CURRENT % IMBALANCE and LINE CURRENT IMBALANCE TIME in VFD_CONF screen

Table 5 — Protective Safety Limits and Control Settings (cont)

MONITORED PARAMETER	ALARM OR ALERT STATE	LIMIT	COMMENTS
P Compressor (Condenser Level) - Condenser Liquid Level Low - Condenser Liquid Level High	169	COND_LEV < max (COND_LOV, 0.1) for 30*CONDTIME and COND_EXV < min Cond. EXV Min Position + 5%	Preset Alert, configure in Setup5
	170	COND_LEV > min (COND_HIV, 4.9) for 30*CONDTIME and COND_EXV>98%	Preset Alert, configure in Setup5
Power - Line Frequency Trip - Power Loss - Phase Reversal	222	47 Hz < LINE FREQUENCY < 63 Hz	Preset Alarm
	214/148 226	DC BUS VOLTAGE<85% for Excessive Time Period Line power phases out of sequence	Preset Alarm/Autorestart Alert Preset Alarm
Motor - Stall - Current Imbalance - Rotation Reversed - Overload Trip - Excessive Amps - Acceleration Fault - Amps not Sensed - Starts Limit Exceeded	238	> 5 stall events within STALL TIME PERIOD	Preset Alarm, Configure STALL DELTA% AMPS and STALL TIME PERIOD in OPTIONS screen
	225	MOTOR CURRENT IMBALANCE>MOTOR CURRENT % IMBALANCE	Configure MOTOR CURRENT % IMBALANCE and MOTOR CURRENT IMBAL TIME in VFD_CONF screen
	221	DISCHARGE PRESSURE decreases more than 2 PSI after VFDSTART = TRUE	Preset Alarm, Must be outside -2 PSI limit for 5 consecutive samples
	217	Any LOAD CURRENT PHASE > 108% for Excessive Time Period	Preset Alarm, Configure MOTOR LOAD ACTIVE DEMAND LIMIT in MAINSTAT screen
	208	PERCENT LOAD CURRENT > 110% for 30 sec.	Preset Alarm
	203	PERCENT LOAD CURRENT > 95% at start-up and VFDSTART = TRUE for 5 to 40 sec	Preset Alarm, PERCENT LOAD CURRENT = AVERAGE LOAD CURRENT/MOTOR RATED LOAD AMPS
	202	PERCENT LOAD CURRENT < 5% and VFD START=TRUE for 20 sec	Preset Alarm, PERCENT LOAD CURRENT = AVERAGE LOAD CURRENT/MOTOR RATED LOAD AMPS
Low Chilled Liquid Flow	100	More than 8 starts in 12 hours	Preset Prestart Alert
	229	CHILLED LIQUID FLOW = FALSE after CHILLED LIQUID PUMP = ON & LIQUID FLOW VERIFY TIME elapsed. CHILLED LIQUID DELTA P < EVAP FLOW DELTA P CUTOFF or CALC EVAP SAT TEMP < EVAP REFRIG TRIPPOINT or EVAPORATOR APPROACH > EVAP APPROACH ALERT and EVAP REFRIG LIQUID TEMP < EVAP REFRIG TRIPPOINT +1	Configurable Alarm, Configure LIQUID FLOW VERIFY TIME in SETUP1 screen. EVAPORATOR APPROACH = LEAVING CHILLED LIQUID TEMP – EVAP REFRIG LIQUID TEMP
Low Cond Liquid Flow	230	COND LIQUID FLOW = FALSE after COND LIQUID PUMP = ON & LIQUID FLOW VERIFY TIME elapsed. CONDENSER LIQUID DELTA P < COND FLOW DELTA P CUTOFF or CONDENSER APPROACH > CONDENSER APPROACH ALERT, or CONDENSER PRESSURE > COND PRESS OVERRIDE + 5	Configurable Alarm, Configure LIQUID FLOW VERIFY TIME in SETUP1 screen. CONDENSER APPROACH = CONDENSER REFRIG TEMP - LEAVING COND LIQUID TEMP
High Approach - Evaporator - Condenser	160	EVAPORATOR APPROACH > EVAP APPROACH ALERT and VFD START = TRUE	Configure EVAP APPROACH ALERT in SETUP1 screen EVAPORATOR APPROACH = LEAVING CHILLED LIQUID TEMP – EVAP REFRIG LIQUID TEMP
	161	CONDENSER APPROACH > COND APPROACH ALERT and VFD START = TRUE	Configure COND APPROACH ALERT in SETUP1 screen.
VFD - Speed Out of Range - Failure to Stop - Communication Failure	245	ACTUAL VFD SPEED < VFD SPEED OUTPUT – 10% or ACTUAL VFD SPEED > VFD SPEED OUTPUT + 10%	Preset Alarm, Must be outside ± 10% range for 75 sec.
	204	PERCENT LOAD CURRENT >15% and VFDSTART = NO for 20 sec	Preset Alarm, PERCENT LOAD CURRENT = AVERAGE LOAD CURRENT/MOTOR RATED LOAD AMPS
	224	Communication with VFD lost for more than 10 sec	Preset Alarm
Rectifier - Overcurrent - High Temperature	241	RECTIFIER OVERCURRENT exceeded limit determined by VFD	Preset Alarm
	218	RECTIFIER TEMPERATURE >exceeds limit calculated by VFD	Preset Alarm
	101	RECTIFIER TEMPERATURE > RECTIFIER TEMP OVERRIDE – 20 deg F (11.1 deg C)	Prestart Alert, Configure RECTIFIER TEMP OVERRIDE in SETUP1 screen

Table 5 — Protective Safety Limits and Control Settings (cont)

MONITORED PARAMETER	ALARM OR ALERT STATE	LIMIT	COMMENTS
Inverter - Overcurrent - High Temperature	246	INVERTER OVERCURRENT exceeded limit determined by VFD	Preset Alarm
	219	INVERTER TEMPERATURE exceeds limit calculated by VFD	Preset Alarm
	109	INVERTER TEMPERATURE > INVERTER TEMP OVERRIDE – 20 deg F (11.1 deg C)	Prestart Alert, Configure INVERTER TEMP OVERRIDE in SETUP1 screen
High VFD Inductor Temperature	255	Inductor Temperature Switch Open	Preset Alarm
DC Bus Voltage - High - Low	205/150	DC BUS VOLTAGE Limit Exceeded, limit is calculated by VFD	Preset Alarm/Autorestart Alert
	215/149	DC BUS VOLTAGE < approximately 407VDC at 400/480V Line Side Voltage	Preset Alarm/Autorestart Alert
Ground Fault	220	GROUND FAULT CURRENT > 7% of Drive Rated Amps Sensed	Preset Alarm
Optional Limits - Spare Temperature - Spare Temperature - Refrigerant Leak Sensor	248,249	SPARE TEMPERATURE > SPARE TEMP LIMIT for 3 consecutive samples	Optional Alarm, Configure SPARE TEMP ENABLE and SPARE TEMP LIMIT in SETUP1 screen Optional Alert, Configure SPARE TEMP ENABLE and SPARE TEMP LIMIT in SETUP1 screen Optional Alarm, configure PPM AT 20 MA and REFRIG-ERANT LEAK ALARM PPM in OPTIONS screen.
	158,159	SPARE TEMPERATURE > SPARE TEMP LIMIT for 3 consecutive samples	
	250	REFRIGERANT LEAK SENSOR PPM > REFRIG LEAK ALARM PPM	

Table 6 — Capacity Overrides

OVERRIDE CAPACITY CONTROL	FIRST STAGE SET POINT			SECOND STAGE SET POINT	SECOND STAGE OVERRIDE TERMINATION
	VIEW/MODIFY ON ICVC SCREEN	DEFAULT VALUE	CONFIGURABLE RANGE	VALUE	VALUE
HIGH CONDENSER PRESSURE (COND PRESS OVERRIDE)	SETUP1	145 PSIG (1000 kPa)	145 to 166 PSIG (1000 to 1145 kPa)	CONDENSER PRESSURE > COND PRESS OVERRIDE + 2.4 PSIG(16.5 kPa) OR CONDENSER PRESSURE > 163 PSIG (1124 kPa)	CONDENSER PRESSURE < CONDENSER PRESS OVERRIDE – 1 PSI (6.9 kPa)
LOW EVAPORATOR TEMPERATURE (REFRIG OVERRIDE DELTA T)	SETUP1	3 ^F (1.7 ^C)	2 to 5 ^F (1.1 to 2.8 ^C)	CALC EVAP SAT TEMP, or EVAP REFRIG LIQUID TEMP < EVAP SAT OVERRIDE TEMP – 1° F (.6° C) NOTE: EVAP SAT OVERRIDE TEMP = EVAP REFRIG TRIPPOINT + REFRIG OVERRIDE DELTA T	CALC EVAP SAT TEMP and EVAP REFRIG LIQUID TEMP > EVAP SAT OVERRIDE TEMP + 2° F (1.1° C)
HIGH MOTOR TEMPERATURE (COMP MOTOR TEMP OVERRIDE)	SETUP1	200° F (93° C)	150 to 200° F (66 to 93° C)	COMP MOTOR WINDING TEMP > COMP MOTOR TEMP OVERRIDE + 10° F (5.6° C)	COMP MOTOR WINDING TEMP < COMP MOTOR TEMP OVERRIDE – 2° F (1.1° C)
HIGH RECTIFIER TEMPERATURE (RECTIFIER TEMP OVERRIDE)	SETUP1	160° F (71° C) (Q,R Compressors) 180° F (82° C) (P Compressor)	155 to 170° F (68 to 77° C) (Q,R Compressors) 155 to 190° F (68 to 88° C) (P Compressor)	RECTIFIER TEMP > RECTIFIER TEMP OVERRIDE + 10° F (5.6° C)	RECTIFIER TEMP < RECTIFIER TEMP OVERRIDE – 5° F (2.8° C)
HIGH INVERTER TEMPERATURE (INVERTER TEMP OVERRIDE)	SETUP1	160° F (71° C)	155 to 170° F (68 to 77° C)	INVERTER TEMP > INVERTER TEMP OVERRIDE + 10° F (5.6° C)	INVERTER TEMP < INVERTER TEMP OVERRIDE – 5° F (2.8° C)

Oil Sump Temperature Control COMPRESSOR ON

The oil heater relay (1C) is energized whenever the chiller compressor is on, and the *OIL SUMP TEMP* is less than 90 F (32.2 C) and *OIL SUMP TEMP* is less than the *CALC EVAP SAT TEMP* plus 35 °F (19.4 °C). The oil heater is then turned off when the *OIL SUMP TEMP* is:

1. More than 92 F (33.3 C).
2. The *OIL SUMP TEMP* is warmer than the *CALC EVAP SAT TEMP* plus 37 °F (20.6 °C).

For units with dual stage heater control the (1C) and (5C) relays are turned OFF when:

1. *OIL SUMP TEMP* is greater than 150 F (65.6 C) or
2. Compressor RPM is greater than *SUMP HEATER TURN OFF SPEED* and *OIL SUMP TEMP* is greater than the *CALC EVAP SAT TEMP* plus *SUMP TURN OFF DELTA TEMP*.

Both (1C) and (5C) relays are turned ON when:

1. Oil Pressure Delta P is less than 20 psig (138 kPa) or
2. Compressor RPM is less than *SUMP HEATER TURN ON SPEED* and either the Difference between *COND REF TEMP* and *CALC EVAP SAT TEMP* is less than *SUMP HEATER TURN ON LIFT*, or *COND REF TEMP* is less than *COND REFRIG TEMP LOW LIMIT*.

When neither of above statements are true for OFF or ON control relay (1C) is ON.

Configurable values for dual stage heater control that allow the service technician to adjust the heater control are located in the *SETUP3* table.

⚠ CAUTION

All oil filter isolation valves should always be left open, except when changing the oil or the oil filter as defined in Changing Oil and Oil Filter section, page 94. Failure to do so may result in equipment shutdown, malfunction, or damage.

Remote Start/Stop Contacts — A remote device, such as a timeclock that uses a set of contacts, may be used to start and stop the chiller. However, the device should not be programmed to start and stop the chiller in excess of 2 or 3 times every 12 hours. If more than 8 starts in 12 hours (the *STARTS IN 12 HOURS* parameter on the *MAINSTAT* screen) occur, an excessive starts prestart alert displays, preventing the chiller from starting. The operator must press the **RESET** softkey on the *ICVC* to override the starts counter and start the chiller. If the chiller records 12 starts (excluding recycle starts or auto restarts after power failure) in a sliding 12-hour period, it can be restarted only by pressing the **RESET** softkey followed by the **LOCAL** or **CCN** softkey. This ensures that, if the automatic system is malfunctioning, the chiller will not repeatedly cycle on and off. If the *AUTO RESTART OPTION* and the *REMOTE CONTACT OPTION* in the *OPTIONS* screen are enabled, the *REMOTE CONTACTS* must be closed in order for the chiller to restart following a power failure. If the automatic restart after a power failure option (*AUTO RESTART OPTION* on the *OPTIONS* screen) is not enabled when a power failure occurs, and if the remote contact is closed, the chiller will indicate an alarm because of the loss of voltage.

The contacts for remote start are wired into the low voltage terminal strip in the control center cabinet (see wiring

diagram). See the certified drawings for further details on contact ratings. The contacts must have 24 vac rating.

Spare Safety and Spare Temperature Inputs

Normally closed (NC) discrete inputs for additional field-supplied safeties may be wired to the spare protective limits input channel in place of the factory-installed jumper. (Wire multiple inputs in series.) The opening of any contact will result in a safety shutdown and a display on the *ICVC*. Refer to the certified drawings for safety contact ratings.

Analog temperature sensors may also be added to the module (*SPARE TEMPERATURE #1* and *#2*). The analog temperature sensors may be configured to cause an alert or alarm on the *CCN* network. The alert will not shut the chiller down. Configuring for alarm state will cause the chiller to shut down. The *SPARE TEMP* channels can be configured for low or high temperature limits in the *SETUP1* screen.

Spare Alarm Contacts — One normally open trip alarm contact is provided in the control center cabinet. The contact ratings are provided in the certified drawings. The contacts are located on terminals 9 and 10 of the hazardous voltage terminal strip in the control center cabinet.

Refrigerant Leak Detector — A 4 to 20 mA / 0 to 5 vdc input is available on the *CCM* module [terminal *J5-5* (–) and *J5-6* (+)] for a refrigerant leak detector. Enabling *REFRIGERANT LEAK OPTION* (*OPTIONS* screen) will allow the *PIC III* controls to go into an alarm state at a user configured level (*REFRIG LEAK ALARM mA*). The input is configured for 4 to 20 mA by setting *CCM* DIP switch 1 on *SW2* at the ON position, or configured for 1 to 5 vdc by setting switch 1 at the OFF position. The output of the refrigerant leak detector is displayed as *REFRIG LEAK SENSOR PPM* on the *MAINSTAT* screen. For a 1 to 5 vdc input, 1 vdc input represents 4 mA displayed and 5 vdc input represents 20 mA displayed.

4 to 20 mA Kilowatt Output — An output is available on the *CCM* module [Terminal *J8-1* (+) and *J8-2* (–)] to represent the power consumption of the chiller. The 4 to 20 mA signal generated by the *CCM* module can be wired to the building automation or energy management system to monitor the chiller's energy consumption. A 4 mA signal represents the chiller in an off state and a 20 mA signal represents the chiller operating at its rated peak kilowatt consumption. The rated peak kilowatt consumption is configured by the user in the *VFD CONF* display screen by the setting the *RATED LINE KILOWATTS* from the Machine Electrical Data Nameplate. The kilowatt output is designed for use with non-grounded controllers with a maximum input impedance of 500 ohms.

Remote Reset of Alarms — A standard feature of the *PIC III* controls is the ability to reset certain faults on a chiller in a shutdown alarm state from a remote location. If the condition which caused the alarm has cleared the fault can be reset and the chiller can be placed back into a normal *CCN* operating mode when the *REMOTE RESET OPTION* (*ICVC_PWD* menu) is set to *ENABLE*. A variety of Carrier Comfort Network® software systems including *ComfortVIEW™* or *Network Service Tool™* can access the *PIC III* controls and reset certain displayed alarms. Third-party software from building automation systems (*BAS*) or energy management systems (*EMS*) can also access the *PIC III* controls through a *Carrier LEI* (Local Equipment Interface) module and reset certain faults that are displayed. All methods would access the *ICVC_PWD* screen and force the *RESET ALARM?* point to *YES* to reset the fault condition. If the *PIC III* controls have determined that it is safe to start the chiller the *CCN MODE?* point (*ICVC_PWD* screen) can be forced to *YES* to place the chiller back into normal *CCN* operating mode. The only exceptions are the following alarms, which cannot be reset from a remote location: *ALARM STATES #200, 201, 204, 206, 217, 218, 219, 220* and *236*. To view alarm codes, refer to

Troubleshooting Guide, Checking Display Messages, page 101. After the alarm has been reset the PIC III controls will increment the *Starts in 12 Hours* counter by one upon restart. If the limit of 8 starts in a 12-hour period occurs Prestart Alert 100 must be manually reset at the local chiller control panel (ICVC).

Condenser Pump Control — The chiller will monitor the condenser pressure (*CONDENSER PRESSURE*) and may turn on the condenser pump if the condenser pressure becomes too high while the compressor is shut down. The condenser pressure override (*COND PRESS OVERRIDE*) parameter is used to determine this pressure point. *COND PRESS OVERRIDE* is found in the SETUP1 display screen, which is accessed from the EQUIPMENT SERVICE table. The default value is 145 psig (543 kPa).

If the *CONDENSER PRESSURE* is greater than or equal to the *COND PRESS OVERRIDE*, the condenser pump will energize to try to decrease the pressure and Alert 151 will be generated. The pump will turn off when the condenser pressure is less than the *COND PRESS OVERRIDE* threshold.

Condenser Freeze Prevention — This control algorithm helps prevent condenser tube freeze-up by energizing the condenser pump relay through terminals 3 and 4 of the hazardous voltage terminal strip (TB2) in the control center. The PIC III module controls the pump and, by starting it, helps to prevent the liquid in the condenser from freezing. The PIC III module can perform this function whenever the chiller is not running except when it is either actively in pumpdown or in pumpdown/lockout with the freeze prevention disabled.

When the *CONDENSER REFRIG TEMP* is less than or equal to the *CONDENSER FREEZE POINT*, the *CONDENSER LIQUID PUMP* is energized until the *CONDENSER REFRIG TEMP* is greater than the *CONDENSER FREEZE POINT* plus 5° F (2.7° C) and the *ENTERING CONDENSER LIQUID TEMPERATURE* is greater than or equal to the *CONDENSER FREEZE POINT*. An alarm (244) is generated if the chiller is in PUMPDOWN mode and the pump is energized. An alert (154) is generated if the chiller is not in PUMPDOWN mode and the pump is energized. If the chiller is in RECYCLE SHUTDOWN mode, the mode will transition to a non-recycle shutdown.

Tower Fan Relay Low and High — Low condenser liquid temperature can cause the chiller to shut down if it causes the condenser refrigerant temperature to be too low. The tower fan relays, located on terminals 5-8 on the hazardous voltage terminal strip (TB2) in the control center, are controlled by the PIC III module to energize and de-energize as the pressure differential between cooler and condenser vessels changes. This prevents excessively low condenser liquid temperatures. The tower fan relay can only accomplish this if the relay has been added to the cooling tower temperature controller.

The tower fan relay low is turned on whenever the condenser liquid pump is running, flow is verified, the difference between cooler and condenser pressure is more than 30 psid (207 kPa), and the *ENTERING CONDENSER LIQUID TEMPERATURE* is greater than 65 F (18.3 C).

The tower fan relay low is turned off when the *CONDENSER LIQUID PUMP* is deenergized, when *CONDENSER LIQUID FLOW* indication is lost, or under the following conditions:

1. *CALC EVAP SAT TEMP* is less than *EVAP SAT OVERRIDE TEMP*.
2. The difference between the *CONDENSER PRESSURE* and *EVAPORATOR PRESSURE* is less than 25 psi (172 kPa).

The tower fan relay high is turned on whenever the condenser liquid pump is running, flow is verified and the

difference between cooler and condenser pressure is more than 35 psid (241.3 kPa) for *ENTERING COND LIQUID TEMPERATURE* greater than the *TOWER FAN HIGH SETPOINT* (SETPOINT menu, default 75 F [24 C]).

The tower fan relay high is turned off when the condenser pump is off, flow is stopped, or the *CALC EVAP SAT TEMP* is less than the *EVAP SAT OVERRIDE TEMP* and *ENTERING CONDENSER LIQUID TEMPERATURE* is less than 70 F (21.1 C). The tower fan relay high is also turned off when the difference between *CONDENSER PRESSURE* and *EVAPORATOR PRESSURE* is less than 28 psid (193 kPa), and *ENTERING CONDENSER LIQUID TEMPERATURE* is less than *TOWER FAN HIGH SETPOINT* minus 3° F (1.6° C).

The *TOWER FAN RELAY LOW* and *HIGH* parameters are accessed from the STARTUP screen.

IMPORTANT: A field-supplied liquid temperature control system for condenser liquid should be installed. The system should maintain the leaving condenser liquid temperature at a temperature that is 20° F (11° C) above the leaving chilled liquid temperature.

CAUTION

The tower fan relay control is not a substitute for a condenser liquid temperature control. When used with a liquid temperature control system, the tower fan relay control can be used to help prevent low condenser liquid temperatures that may damage equipment.

Auto. Restart After Power Failure — This option may be enabled or disabled and may be viewed or modified on the OPTIONS screen, which is accessed from the SERVICE table. If the *AUTO. RESTART* option is enabled, the chiller will start up automatically after a power failure has occurred (after a single cycle dropout; low, high, or loss of voltage; and the power is within ±10% of normal). The 15 and 3-minute inhibit timers are ignored during this type of start-up.

When power is restored after the power failure, a power failure restart will be enabled and the control allowed to AUTORESTART the chiller, starting with the chilled liquid pump(s), if start-up conditions are met.

If power to the ICVC module has been off for more than 3 hours or the timeclock has been set for the first time, the compressor will start with the slowest temperature-based ramp load rate possible in order to minimize oil foaming.

Fast Power Source Transfers — When the electrical system is being prepared to transfer power from utility power to generator power or from generator power back to utility power, and the power transfer is an open transition type, and time to transfer is less than 5 seconds, the chiller should be stopped before the transfer occurs and restarted after the transfer has been completed. If the chiller is not stopped before the transfer occurs, alarms on the chiller can occur that must be manually reset, such as a circuit breaker trip. To accomplish shutdown and restart automatically, a set of dry contacts should be opened 30 to 60 seconds before the transfer occurs, then closed after the transfer is complete to restart the chiller. The contacts must be wired to the Remote START/STOP contact in the starter or VFD (see the field wiring diagrams, pages 134-148) and the Remote Start contact configuration must be enabled. If power transfers take 5 seconds or longer, the chiller Auto Restart after Power Failure feature (if enabled) will automatically restart the chiller.

Liquid/Brine Temperature Reset — Three types of chilled liquid or brine setpoint temperature reset are available and can be viewed or modified on the TEMP CTL screen, which is accessed from the EQUIPMENT SERVICE table.

The ICVC default screen indicates when the chilled liquid reset is active. *TEMPERATURE RESET* on the MAINSTAT screen indicates the amount of reset. The CONTROL POINT will be determined by adding the *TEMPERATURE RESET* to the *ECL SETPOINT* or *LCL SETPOINT*.

To activate a reset type, access the TEMP_CTL screen and input all configuration information for that reset type. Then, input the reset type number (1, 2, or 3) in the SELECT/ENABLE RESET TYPE input line.

RESET TYPE 1: 4 to 20 mA (0 to 5 vdc) *TEMPERATURE RESET* — Reset Type 1 is an automatic chilled liquid temperature reset based on a remote temperature sensor input configured for either an externally powered 4 to 20 mA or a 0 to 5 vdc signal. Reset Type 1 permits up to ± 30 F (± 17 C) of automatic reset to the *ECL SETPOINT* or *LCL SETPOINT*.

The auto, chilled liquid reset is hardwired to CCM terminals J5-3 (–) and J5-4 (+). Switch setting number 2 on SW2 will determine the type of input signal. With the switch set at the ON position the input is configured for an externally powered 4 to 20 mA signal. With the switch in the OFF position the input is configured for an external 0 to 5 vdc signal. One of the following modifications are also required when using a 1 to 5 vdc temperature reset signal:

1. Install a 25 ohm resistor in series with the (+) voltage lead connected to CCM terminal J5-4.
2. Modify the input voltage signal with an external controller software to calibrate the temperature interpreted by the CCM. The controller should provide 4.54 v at 100% of the controller's output range and 0.91 v at 0% of the controller's output range.

RESET TYPE 2: *REMOTE TEMPERATURE RESET* — Reset Type 2 is an automatic chilled liquid temperature reset based on a remote temperature sensor input signal. Reset Type 2 permits ± 30 F (± 17 C) of automatic reset to the *ECL SETPOINT* or *LCL SETPOINT* based on a temperature sensor wired to the CCM module (see wiring diagrams or certified drawings). The temperature sensor must be wired to CCM terminal J4-13 and J4-14.

To configure Reset Type 2, enter the temperature of the remote sensor at the point where no temperature reset will occur (*REMOTE TEMP* → *NO RESET*). Next, enter the temperature at which the full amount of reset will occur (*REMOTE TEMP* → *FULL RESET*). Then, enter the maximum amount of reset required to operate the chiller (*DEGREES RESET*). Reset Type 2 can now be enabled.

RESET TYPE 3 — Reset Type 3 is an automatic chilled liquid temperature reset based on the difference between *ENTERING CHILLED LIQUID* and *LEAVING CHILLED LIQUID* temperature. Reset Type 3 adds ± 30 F (± 17 C) based on the chilled liquid temperature difference.

To configure Reset Type 3, enter the chilled liquid temperature difference (the difference between entering and leaving chilled liquid) at which no temperature reset occurs (*CHL DELTA T* → *NO RESET*). This chilled liquid temperature difference is usually the full design load temperature difference. Next, enter the difference in chilled liquid temperature at which the full amount of reset occurs (*CHL DELTA T* → *FULL RESET*). Finally, enter the amount of temperature reset (*DEGREES RESET*). Reset Type 3 can now be enabled.

Demand Limit Control Option — The demand limit control option (*20 mA DEMAND LIMIT OPT*) is externally controlled by a 4 to 20 mA or 1 to 5 vdc signal from an energy management system (EMS). The option is set up on the RAMP_DEM screen. When enabled, 4 mA is the 100% demand set point with an operator-configured minimum demand at a 20 mA set point (*DEMAND LIMIT AT 20 mA*).

The auto, demand limit is hardwired to terminals J5-1 (–) and J5-2 (+) on the CCM. Switch setting number 1 on CCM SW2 will determine the type of input signal. With the switch

set at the ON position the input is configured for an externally powered 4 to 20 mA signal. With the switch in the OFF position the input is configured for an external 1 to 5 vdc signal. One of the following modifications are also required when using a 1 to 5 vdc *DEMAND LIMIT* signal:

1. Install a 25 ohm resistor in series with the (+) voltage lead connected to CCM terminal J5-2.
2. Modify the input voltage signal with an external controller software to calibrate the temperature interpreted by the CCM. The controller should provide 4.54 v at 100% of the controller's output range and 0.91 v at 0% of the controller's output range.

Hot Gas Bypass (Optional) Algorithm (See Fig. 31-33) — If a hot gas bypass solenoid valve is present and the *HGBP OPTION* in the OPTIONS table is set to 1 or 2, this operator configurable feature can determine if load conditions are too low for the compressor and corrective action can be taken.

When the *HGBP OPTION* = 0: the HGBP algorithm is disabled.

When the *HGBP OPTION* = 1, the algorithm determines if corrective action is necessary by checking the chiller operating point against an operator configured threshold. The threshold is calculated from a combination of the difference between Entering and Leaving Chilled Liquid temperatures and the difference between *CONDENSER PRESSURE* and *EVAPORATOR PRESSURE*. The operator configured data points are the *MIN LOAD POINT(T1/P1)* and the *FULL LOAD POINT (T2/P2)*. These points have default settings defined in the OPTIONS screen and on Table 3. A line is drawn between these points as shown in Fig. 31 and 32. The default Load Points (to prevent compressor stall) are shown.

Whenever the *ACTIVE DELTA T* (actual temperature difference between the *LEAVING CHILLED LIQUID* and *ENTERING CHILLED LIQUID*) is on the left side of the line plotted in Fig. 31 and 32, the algorithm will energize the hot gas bypass valve to falsely load the chiller. If *ACTIVE DELTA T* falls to the right side of the line plotted in Fig 31 and 32 by more than the *HGBP DEADBAND*, the hot gas bypass valve is deenergized. The HGBP valve is also deenergized if *ACTIVE DELTA P* (actual difference between *CONDENSER PRESSURE* and *EVAPORATOR PRESSURE*) falls to below *HGBP DELTA P1*. Instructions to configure the *MIN LOAD POINT(T1/P1)* and *FULL LOAD POINT(T2/P2)* are on page 76.

When the *HGBP OPTION* = 2, the option energizes the Hot Gas Bypass relay solely based on the *VFD TARGET SPEED*. Evaluation of the *VFD TARGET SPEED* begins at the completion of ramp loading. If the *VFD TARGET SPEED* is less than the Minimum Speed plus the *HGBP ON DELTA SPEED* for 3 seconds then the Hot Gas Bypass is energized. When the VFD Target Speed is greater than the Minimum Speed plus the *HGBP ON DELTA SPEED* and the *HGBP OFF DELTA SPEED* for 3 seconds then the Hot Gas Bypass relay is deenergized. See Fig. 33.

Head Pressure Output Reference (See Fig. 34) — The PIC III controls output a 4 to 20 mA signal for the configurable Delta P (*CONDENSER PRESSURE – EVAPORATOR PRESSURE*) reference curve shown in Fig. 34. The *DELTA P AT 100%* (default at 50 psi), *DELTA P AT 0%* (default at 25 psi) and *MINIMUM OUTPUT* are configurable in the EQUIPMENT SERVICE-OPTIONS table. When configuring this output, ensure that minimum requirements for proper condenser FLASC orifice performance are maintained. The 4 to 20 mA output from VFD TB1 terminals 17 and 18 can be used as a reference to control a tower bypass valve, tower speed control, or condenser pump speed control. The head

pressure output is designed for use with non-grounded controllers with a maximum input impedance of 500 ohms.

NOTE: It is up to the site design engineering agent to integrate this analog output with any external system device(s) to produce the desired effect. Carrier does not make any claim that this output is *directly* usable to control any specific piece of equipment (that is, without further control elements or signal conditioning), although it may be.

The head pressure reference output will be on whenever the condenser pump is operating. It may also be manually operated in *CONTROLS TEST*. When the head pressure differential is less than the value entered for *DELTA P AT 0%*, the output will be maintained at 4 mA. The output is 2 mA when the chiller is not running.

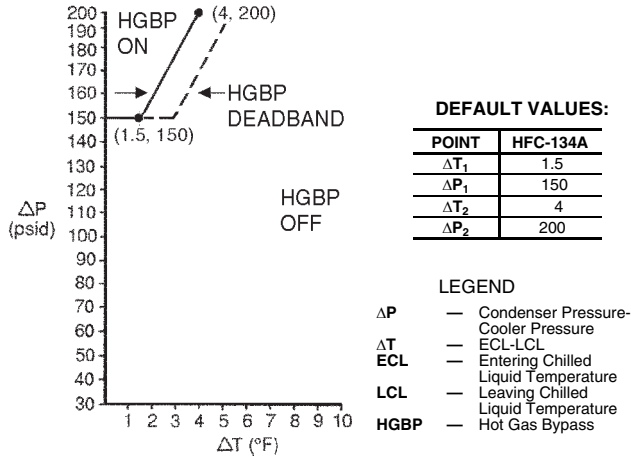

Fig. 31 — 23XRV Hot Gas Bypass Option 1 (English)

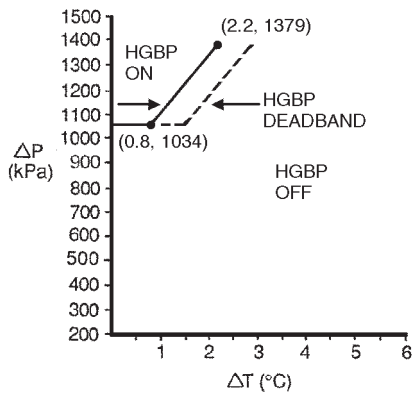

Fig. 32 — 23XRV Hot Gas Bypass Option 1 (SI)

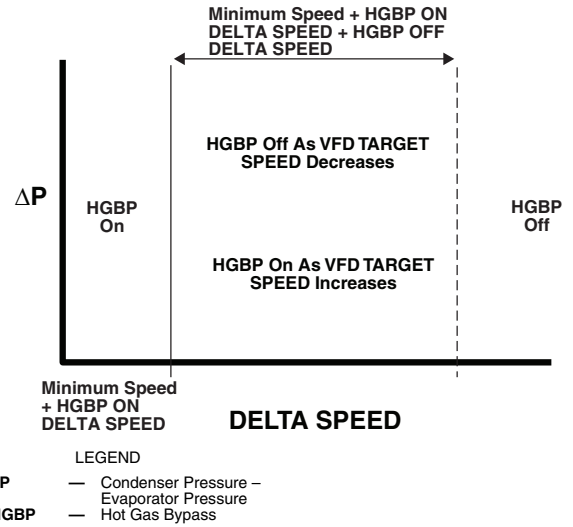

Fig. 33 — Hot Gas Bypass Option 2

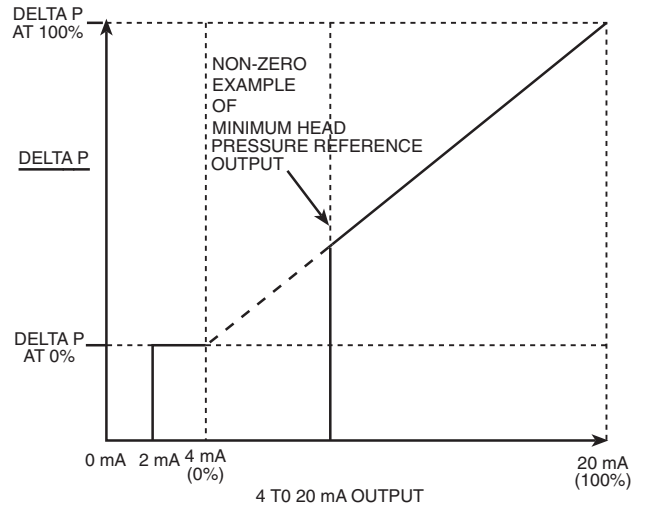

Fig. 34 — Head Pressure Output Reference Control

Lead/Lag Control — The lead/lag control system automatically starts and stops a lag or second chiller in a 2-chiller liquid system. A third chiller can be added to the lead/lag system as a standby chiller to start up in case the lead or lag chiller in the system has shut down during an alarm condition and additional cooling is required. Refer to Fig. 27 and 28 for menu, table, and screen selection information. The output is 2 mA when the chiller is not running.

NOTE: The lead/lag function can be configured on the LEADLAG screen, which is accessed from the SERVICE menu and EQUIPMENT SERVICE table. See Table 3, Example 27. Lead/lag status during chiller operation can be viewed on the LL_MAINT display screen, which is accessed from the SERVICE menu and CONTROL ALGORITHM STATUS table. See Table 3, Example 14.

Lead/Lag System Requirements:

- All chillers in the system must have software capable of performing the lead/lag function.
- Liquid pumps MUST be energized from the PIC III controls.
- Liquid flows should be constant.
- The CCN time schedules for all chillers must be identical. The lag chiller set point and demand limit are controlled by lead chiller only and cannot be written to by an external automation system.
- • For series flow chiller designs with entering condenser water below 75°F an external controller such as ChillerVu™ is to be utilized.

Operation Features:

- 2-chiller lead/lag
- addition of a third chiller for backup
- manual rotation of lead chiller
- load balancing if configured
- staggered restart of the chillers after a power failure
- chillers may be piped in parallel or in series chilled liquid flow

COMMON POINT SENSOR INSTALLATION — In all cases lead/lag operation does not require a common point chilled liquid sensor. Common point sensors (Spare Temp #1 and #2) can be added to the CCM module, if desired. Spare Temp #1 and #2 are wired to plug J4 terminals 25-26 and 27-28 (J4 lower, respectively). See the Lead/Lag Control Wiring figures on pages 147 and 148.

NOTE: If the common point sensor option is chosen on a chilled liquid system, each chiller should have its own common point sensor installed. Each chiller uses its own common point sensor for control when that chiller is designated as the lead chiller. The PIC III controls cannot read the value of common point sensors installed on the other chillers in the chilled liquid system.

If leaving chilled liquid control (*ECL CONTROL OPTION* is set to 0 [DSABLE], TEMP_CTL screen) and a common point sensor is desired (*COMMON SENSOR OPTION* in LEADLAG screen selected as 1) then the common point temperature sensor is wired in Spare Temp #1 position on the CCM.

If the entering chilled liquid control option (*ECL CONTROL OPTION*) is enabled (configured in TEMP_CTL screen) and a common point sensor is desired (*COMMON SENSOR OPTION* in LEADLAG screen selected as 1) then the sensor is wired in Spare Temp #2 position on the CCM.

When installing chillers in series, a common point sensor should be used. If a common point sensor is not used, the leaving chilled liquid sensor of the upstream chiller must be moved into the leaving chilled liquid pipe of the downstream chiller.

If return chilled liquid control is required on chillers piped in series, the common point return chilled liquid sensor should be installed. If this sensor is not installed, the return chilled liquid sensor of the downstream chiller must be relocated to the return chilled liquid pipe of the upstream chiller.

To properly control the common supply point temperature sensor when chillers are piped in parallel, the liquid flow path through the shutdown chillers must be isolated so no liquid bypass around the operating chiller occurs. The common point sensor option must not be used if liquid bypass around the operating chiller is occurring.

CHILLER COMMUNICATION WIRING — Refer to the chiller's Installation Instructions, Carrier Comfort Network® Interface section for information on chiller communication wiring.

LEAD/LAG OPERATION — The PIC III control system not only has the ability to operate 2 chillers in lead/lag, but it can also start a designated standby chiller when either the lead or lag chiller is faulted and capacity requirements are not met. The lead/lag option only operates when the chillers are in CCN mode. If any other chiller configured for lead/lag is set to the LOCAL or OFF modes, it will be unavailable for lead/lag operation.

Lead/Lag Chiller Configuration and Operation

- A chiller is designated the lead chiller when its *LEAD/LAG CONFIGURATION* value on the LEADLAG screen is set to "1."
- A chiller is designated the lag chiller when its *LEAD/LAG CONFIGURATION* value is set to "2."
- A chiller is designated as a standby chiller when its *LEAD/LAG CONFIGURATION* value is set to "3."
- A value of "0" disables the lead/lag designation of a chiller.

To configure the *LAG ADDRESS* value on the LEADLAG screen, always enter the address of the other chiller on the system. For example, to configure chiller A, enter the address for chiller B as the lag address. To configure chiller B, enter the address for chiller A as the lag address. This makes it easier to rotate the lead and lag chillers.

If the address assignments in the *LAG ADDRESS* and *STANDBY ADDRESS* parameters conflict, the lead/lag function is disabled and an alert (!) message displays. For example, if the *LAG ADDRESS* matches the lead chiller's address, the lead/lag will be disabled and an alert (!) message displayed. The lead/lag maintenance screen (LL_MAINT) displays the message INVALID CONFIG in the *LEAD/LAG: CONFIGURATION* and *CURRENT MODE* fields. Refer to Table 7.

Table 7 — Invalid Lead/Lag Addresses

LEAD/LAG CONFIGURATION (IN LEAD/LAG SCREEN)	INVALID CONDITIONS
1 (Lead)	Local Address (Lead) = Lag Address
	Standby Chiller Option = Enable and Local Address (Lead) = Standby Address
	Standby Chiller Option = Enable and Lag Address = Standby Address
2 (Lag)	Local Address (Lead) = Lag Address
	Standby Chiller Option = Enable and Local Address (Lag) = Standby Address

The lead chiller responds to normal start/stop controls such as the occupancy schedule, a forced start or stop, and remote start contact inputs. After completing start-up and ramp loading, the PIC III module evaluates the need for additional capacity. If additional capacity is needed, the PIC III module initiates the start-up of the chiller configured at the *LAG ADDRESS*. If the lag chiller is faulted (in alarm) or is in the OFF or LOCAL modes, the chiller at the *STANDBY ADDRESS* (if configured) is requested to start. After the second chiller is started and is running, the lead chiller monitors conditions and evaluates

whether the capacity has been reduced enough for the lead chiller to sustain the system alone. If the capacity is reduced enough for the lead chiller to sustain the *CONTROL POINT* temperature alone, then the operating lag chiller is stopped.

If the lead chiller is stopped in CCN mode for any reason other than an alarm (*) condition, the lag and standby chillers are also stopped. If the configured lead chiller stops for an alarm condition, the configured lag chiller takes the lead chiller's place as the lead chiller, and the standby chiller serves as the lag chiller.

If the configured lead chiller does not complete the start-up before the *PRESTART FAULT TIMER* (configured in LEADLAG screen) elapses, then the lag chiller starts and the lead chiller shuts down. The lead chiller then monitors the start request from the acting lead chiller. The *PRESTART FAULT TIMER* is initiated at the time of a start request. The *PRESTART FAULT TIMER* provides a timeout if there is a prestart alert condition that prevents the acting lead chiller from starting in a timely manner. The *PRESTART FAULT TIMER* parameter is on the LEADLAG screen, which is accessed from the EQUIPMENT SERVICE table of the SERVICE menu.

If the lag chiller does not achieve start-up before the *PRESTART FAULT TIMER* elapses, the lag chiller stops, and the standby chiller is requested to start, if configured and ready.

Standby Chiller Configuration and Operation — A chiller is designated as a standby chiller when its *LEAD/LAG CONFIGURATION* value on the LEADLAG screen is set to "3." The standby chiller can operate as a replacement for the lag chiller only if one of the other two chillers is in an alarm (*) condition (as shown on the ICVC panel). If both lead and lag chillers are in an alarm (*) condition, the standby chiller defaults to operate in CCN mode, based on its configured occupancy schedule and remote contacts input.

Lag Chiller Start-Up Requirements — Before the lag chiller can be started, the following conditions must be met:

1. The lag chiller status indicates it is in CCN mode and is not in an alarm condition. If the current lag chiller is in an alarm condition, the standby chiller becomes the active lag chiller, if it is configured and available.
2. Lead chiller ramp loading must be complete.
3. The configured *LAG START TIMER* entry has elapsed. The *LAG START TIMER* starts when the lead chiller ramp loading is completed or when a lag chiller stops. The *LAG START TIMER* entry is on the LEADLAG screen, which is accessed from the EQUIPMENT SERVICE table of the SERVICE menu.
4. Lead chiller *ACTIVE DEMAND LIMIT* (see the MAINSTAT screen) value must be greater than 95% of full load amps.
5. Lead CHILLED LIQUID TEMP must be greater than the *CONTROL POINT* temperature (see the MAINSTAT screen) plus $\frac{1}{2}$ the *CHILLED LIQUID DEADBAND* temperature (see the SETUP1 screen).

NOTE: The chilled liquid temperature sensor may be the leaving chilled liquid sensor, the return liquid sensor, the common supply liquid sensor, or the common return liquid sensor, depending on which options are configured and enabled.

6. Lead chiller temperature pulldown rate (*TEMP PULLDOWN DEG/MIN* on the TEMP_CTL screen) of the chilled liquid temperature is less than 0.5° F (0.27° C) per minute for a cumulative duration greater than the *PULLDOWN TIMER* setting in the LEADLAG screen.

When all the above requirements have been met, the lag chiller is commanded to a STARTUP mode (CONTROL flashing next to the point value on the STATUS table). The PIC III controls then monitor the lag chiller for a successful start. If the

lag chiller fails to start, the standby chiller, if configured, is started.

NOTE: When the lag chiller is in operation, CONTROL flashes on the right side of the status screen for CHILLER START/STOP, DEMAND LIMIT, and CONTROL POINT (CAPACITY).

Lead/Lag Pulldown Timer Operation — Some lead/lag chiller applications with large chilled liquid loop volumes must accommodate intermittent slugs of warm *ENTERING CHILLED LIQUID* for short time periods. This type of transient condition can result when a control valve rapidly opens to allow flow through a previously isolated branch or zone within the chilled liquid system. A *PULLDOWN TIMER* can be configured to delay starting the lag chiller so it does not excessively cycle on and off for short time periods when intermittent slugs of warm *ENTERING CHILLED LIQUID* pass through the chillers. A larger *PULLDOWN TIMER* entry gives the warm slug of water more time to pass through the chillers before the lag chiller will start.

The chiller *CONTROL POINT* can be configured to either *LEAVING CHILLED LIQUID* or *ENTERING CHILLED LIQUID* temperature. The PIC controls monitor the temperature pulldown rate of the CHILLED LIQUID and display the result as *CHILL LIQ PULLDOWN/MIN* in the HEAT_EX screen. Samples of the CHILLED LIQUID temperature are taken once every 10 seconds and compared against the previous CHILLED LIQUID sample. A positive value of *CHILL LIQ PULLDOWN/MIN* indicates that the CHILLED LIQUID temperature is decreasing between successive samples. If *CHILL LIQ PULLDOWN/MIN* rate is a minimum of 0.5 degrees F per minute then the PULLDOWN: SATISFIED parameter in the LL MAINT screen displays "YES", otherwise, the PULLDOWN: SATISFIED parameter displays "NO."

If the lead chiller is unable to achieve the CONTROL POINT, the lag chiller will not start unless the lead chiller is unable to maintain a *CHILL LIQ PULLDOWN/MIN* rate of 0.5 degrees F per minute for a time period equal to the number of minutes entered in the *PULLDOWN TIMER* parameter. *PULLDOWN TIME* in the LL MAINT screen displays the remaining delay left before the lag chiller is allowed to start based on the pulldown timer. *PULLDOWN TIME* will count down starting at the value entered in *PULLDOWN TIMER* when Ramp Loading is complete and when PULLDOWN: SATISFIED = NO.

The lag chiller pulldown start condition is met when *PULLDOWN TIME* lapses to 0.0 min.

If PULLDOWN: SATISFIED changes to "YES" as the *PULLDOWN TIME* is counting down to zero, the *PULLDOWN TIME* will start to count back up provided that the CHILLED LIQUID temperature has not fallen to less than the *CONTROL POINT* plus one half of the *CHILLED LIQUID DEADBAND*. The *PULLDOWN TIME* will start to count back down again should PULLDOWN: SATISFIED change back to "NO." The *PULLDOWN TIME* will be immediately reset to the value entered in the *PULLDOWN TIMER* parameter if the CHILLED LIQUID temperature decreases to less than the *CONTROL POINT* plus one half of the *CHILLED LIQUID DEADBAND*.

Lag Chiller Shutdown Requirements — The following conditions must be met in order for the lag chiller to be stopped.

1. Lead chiller *AVERAGE LINE CURRENT* or *PERCENT MOTOR KILOWATTS* load value (on the MAINSTAT screen) is less than the Lead Chiller Percent Capacity.

NOTE: Lead Chiller Percent Capacity = $105 - LAG \% CAPACITY$. The *LAG \% CAPACITY* parameter is on the LEADLAG screen, which is accessed from the EQUIPMENT SERVICE table on the SERVICE menu.

- The lead chiller *CHILLED LIQUID TEMP* is less than the *CONTROL POINT* temperature (see the MAINSTAT screen) plus on half of the *CHILLED LIQUID DEADBAND* temperature (see the SETUP1 screen).
- The configured *LAG STOP TIMER* entry has elapsed. The *LAG STOP TIMER* starts when the lead chiller *CHILLED LIQUID TEMP* is less than the chilled liquid *CONTROL POINT* plus $\frac{1}{2}$ of the *CHILLED LIQUID DEADBAND* and the lead chiller compressor motor load (*PERCENT MOTOR KILOWATTS* or *AVERAGE LINE CURRENT* on the MAINSTAT screen) is less than the lead chiller percent capacity.

NOTE: The use of *AVERAGE LINE CURRENT* or *PERCENT MOTOR KILOWATTS* in the Lag chiller shutdown decision is based on the *DEMAND LIMIT SOURCE* configuration in the RAMP DEM screen. If *DEMAND LIMIT SOURCE* = 0 then *AVERAGE LINE CURRENT* will be used. If *DEMAND LIMIT SOURCE* = 1 then *PERCENT MOTOR KILOWATTS* will be used.

FAULTED CHILLER OPERATION — If the lead chiller shuts down because of an alarm (*) condition, it stops communicating to the lag and standby chillers. After 30 seconds, the lag chiller becomes the acting lead chiller and starts and stops the standby chiller, if necessary.

If the lag chiller goes into alarm when the lead chiller is also in alarm, the standby chiller reverts, after 60 seconds, to a stand-alone CCN mode of operation.

If the lead chiller is in an alarm (*) condition (as shown on the ICVC panel), press the **RESET** softkey to clear the alarm. The lead chiller is placed in CCN mode. The lead chiller communicates and monitors the RUN STATUS of the lag and standby chillers. If both the lag and standby chillers are running, the lead chiller does not attempt to start and does not assume the role of lead chiller until either the lag or standby chiller shuts down. If only one chiller is running, the lead chiller waits for a start request from the operating chiller. When the configured lead chiller starts, it resumes its role as lead chiller.

If the lag chiller is the only chiller running and the lead chiller is ready to resume its role as a lead chiller then the lag chiller will perform a *RECOVERY START REQUEST* (LL_MAINT screen). The lead chiller will start up when the following conditions are met.

- Lag chiller ramp loading must be complete.
- Lag *CHILLED LIQUID TEMP* (MAINSTAT screen) is greater than *CONTROL POINT* plus $\frac{1}{2}$ the *CHILLED LIQUID DEADBAND* temperature.
- Lag chiller *ACTIVE DEMAND LIMIT* value must be greater than 95% of full load amps.
- Lag chiller temperature pulldown rate (*TEMP PULLDOWN DEG/MIN*) of the chilled liquid temperature is less than 0.5 F (0.27 C) per minute for a cumulative time duration greater than the *PULLDOWN TIMER* setting in the lag chiller's LEADLAG screen.
- The standby chiller is not running as a lag chiller.
- The configured *LAG START TIMER* has elapsed. The *LAG START TIMER* is started when ramp loading is completed.

LOAD BALANCING — When the *LOAD BALANCE OPTION* (see LEADLAG screen) is enabled, the lead chiller sets the *ACTIVE DEMAND LIMIT* in the lag chiller to the lead chiller's *AVERAGE LINE CURRENT* or *PERCENT MOTOR KILOWATTS* value in the POWER screen. This value has limits of 40% to 100%. When the lag chiller *ACTIVE DEMAND LIMIT* is set, the *CONTROL POINT* is assigned a

value of 3° F (1.67° C) less than the lead chiller's *CONTROL POINT* value to better match the lead chiller's load level. If the *LOAD BALANCE OPTION* is disabled, the *ACTIVE DEMAND LIMIT* and the *CONTROL POINT* are forced to the same value as the lead chiller.

AUTO. RESTART AFTER POWER FAILURE — When an Auto restart condition occurs, each chiller may have a delay added to the start-up sequence, depending on its lead/lag configuration. The lead chiller does not have a delay. The lag chiller has a 45-second delay. The standby chiller has a 90-second delay. The delay time is added after the chiller liquid flow is verified. The delay must elapse before the oil pump is turned on. The Auto restart delay sequence occurs whether the chiller is in CCN or LOCAL mode and is intended to stagger the compressor motor starts. Preventing the motors from starting simultaneously helps reduce the inrush demands on the building power system.

Attach to Network Device Control — The Service menu includes the ATTACH TO NETWORK DEVICE screen. From this screen the operator can:

- Attach the ICVC to any CCN device, if the chiller has been connected to a CCN network. This may include other PIC III-controlled chillers.
- upgrade software

Figure 35 shows the ATTACH TO NETWORK DEVICE screen. The *LOCAL* parameter is always the ICVC module address of the chiller on which it is mounted. Whenever the controller identification of the ICVC changes, the change is reflected automatically in the BUS and ADDRESS columns for the local device. See Fig. 28. Default address for local device is BUS 0 ADDRESS 1.

When the ATTACH TO NETWORK DEVICE screen is accessed, information can not be read from the ICVC on any device until one of the devices listed on that screen is attached. The ICVC erases information about the module to which it was attached to make room for information on the new device. Therefore, a CCN module must be attached when this screen is entered.

To attach any CCN device, highlight it using the **SELECT** softkey and press the **ATTACH** softkey. The message "UPLOADING TABLES, PLEASE WAIT" displays. The ICVC then uploads the highlighted device or module. If the module address cannot be found, the message "COMMUNICATION FAILURE" appears. The ICVC then reverts back to the ATTACH TO DEVICE screen. Try another device or check the address of the device that would not attach. The upload process time for each CCN module is different. In general, the uploading process takes 1 to 2 minutes. Before leaving the ATTACH TO NETWORK DEVICE screen, select the local device. Otherwise, the ICVC will be unable to display information on the local chiller.

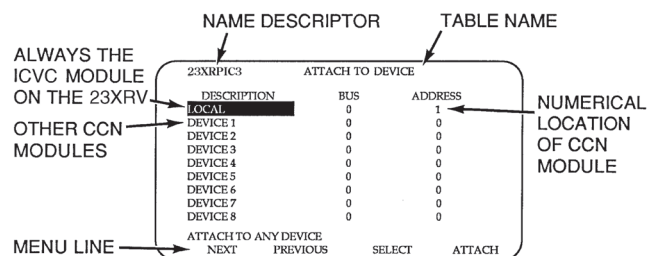

Fig. 35 — Example of Attach to Network Device Screen

ATTACHING TO OTHER CCN MODULES — If the chiller ICVC has been connected to a CCN Network or other PIC-controlled chillers through CCN wiring, the ICVC can be used to view or change parameters on the other controllers. Other PIC III chillers can be viewed and set points changed (if the other unit is in CCN control), if desired, from this particular ICVC module.

If the module number is not valid, the “COMMUNICATION FAILURE” message will show and a new address number must be entered or the wiring checked. If the module is communicating properly, the “UPLOAD IN PROGRESS” message will flash and the new module can now be viewed.

Whenever there is a question regarding which module on the ICVC is currently being shown, check the device name descriptor on the upper left hand corner of the ICVC screen. See Fig. 35.

When the CCN device has been viewed, the ATTACH TO NETWORK DEVICE table should be used to attach to the PIC that is on the chiller. Move to the ATTACH TO NETWORK DEVICE table (LOCAL should be highlighted) and press the **ATTACH** softkey to upload the LOCAL device. The ICVC for the 23XRV chiller will be uploaded and default screen will display.

NOTE: The ICVC will not automatically reattach to the local module on the chiller. Press the **ATTACH** softkey to attach to the LOCAL device and view the local chiller operation.

Service Operation — An overview of the tables and screens available for the SERVICE function is shown in Fig. 28.

TO ACCESS THE SERVICE SCREENS — When the SERVICE screens are accessed, a password must be entered.

1. From the main MENU screen, press the **SERVICE** softkey. The softkeys now correspond to the numerals 1, 2, 3, 4.
2. Press the four digits of the password, one at a time. An asterisk (*) appears as each digit is entered.

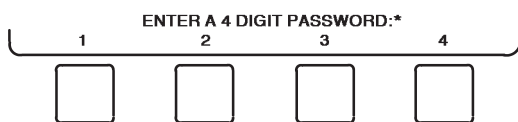

NOTE: The initial factory-set password is 1-1-1-1. If the password is incorrect, an error message is displayed.

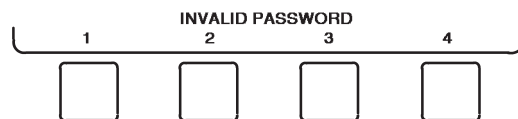

If this occurs, return to Step 1 and try to access the SERVICE screens again. If the password is correct, the softkey labels change to:

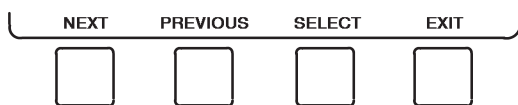

NOTE: The SERVICE screen password can be changed by entering the ICVC CONFIGURATION screen under SERVICE menu. The password is located at the bottom of the menu. Contact Carrier Service to override the ICVC password if it is lost.

The ICVC screen displays the following list of available SERVICE screens:

- Alarm History
- Alert History
- Control Test
- Control Algorithm Status
- Equipment Configuration
- VFD Config Data
- Equipment Service
- Time and Date
- Attach to Network Device
- Log Out of Device
- ICVC Configuration

See Fig. 28 for additional screens and tables available from the SERVICE screens listed above. Use the **EXIT** softkey to return to the main MENU screen.

NOTE: To prevent unauthorized persons from accessing the ICVC service screens, the ICVC automatically signs off and password-protects itself if a key has not been pressed for 15 minutes. The sequence is as follows. Fifteen minutes after the last key is pressed, the default screen displays, the ICVC screen light goes out (analogous to a screen saver), and the ICVC logs out of the password-protected SERVICE menu. The STATUS, SCHEDULE, and SETPOINT screens can be accessed without the password by pressing the appropriate softkey.

TO LOG OUT OF DEVICE — To access this screen and log out of a network device, from the default ICVC screen, press the **MENU** and **SERVICE** softkeys. Enter the password and, from the SERVICE menu, highlight LOG OUT OF NETWORK DEVICE and press the **SELECT** softkey. The ICVC default screen will now be displayed.

HOLIDAY SCHEDULING (Fig. 36) — The time schedules may be configured for special operation during a holiday period. When modifying a time period, the “H” in the far right column of the OCCPC01S, OCCPC02S or OCCPC03S time schedule screen signifies that the period is applicable to a holiday. (See Fig. 29.)

The *TIME BROADCAST ENABLE* function must be activated for the holidays configured on the HOLIDAYS screen to work properly. Access the BRODEF screen from the EQUIPMENT CONFIGURATION table, highlight *TIME BROADCAST ENABLE* and select ENABLE to activate function. Note that when the chiller is connected to a CCN network, only one chiller or CCN device can be configured as the broadcast device. The controller that is configured as the broadcaster is the device responsible for transmitting holiday, time, and daylight-savings dates throughout the network.

To access the BRODEF screen, see the SERVICE menu structure, Fig. 28.

To view or change the holiday periods for up to 18 different holidays, perform the following operation:

1. At the Main Menu screen, press **SERVICE** to access the Service menu.
2. If not logged on, follow the instructions for ATTACH TO NETWORK DEVICE CONTROL or To Log Out of Device. Once logged on, press **NEXT** until EQUIPMENT CONFIGURATION is highlighted.
3. Once EQUIPMENT CONFIGURATION is highlighted, press **SELECT** to access.
4. Press **NEXT** until HOLIDAYS is highlighted. This is the Holiday Definition table.
5. Press **SELECT** to enter the Data Table Select screen. This screen lists 18 holiday tables.

6. Press **[NEXT]** to highlight the holiday table that is to be viewed or changed. Each table is one holiday period, starting on a specific date, and lasting up to 99 days.
7. Press **[SELECT]** to access the holiday table. The Configuration Select table now shows the START MONTH, START DAY, and DURATION of the holiday period.
8. Press **[NEXT]** or **[PREVIOUS]** to highlight the START MONTH, START DAY, and DURATION.
9. Press **[SELECT]** to modify the month, day, or duration.
10. Press **[INCREASE]** or **[DECREASE]** to change the selected value.
11. Press **[ENTER]** to save the changes.
12. Press **[EXIT]** to return to the previous menu.

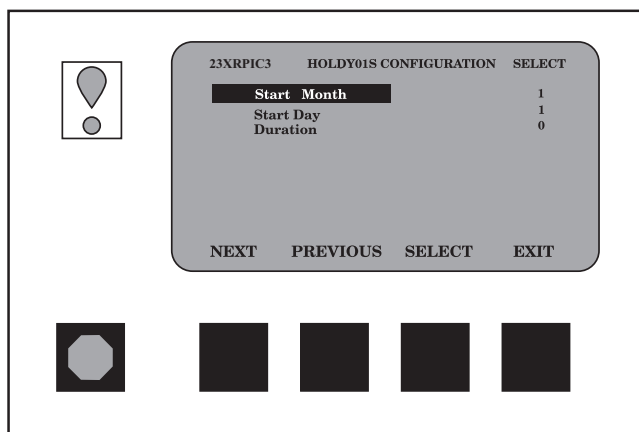

Fig. 36 — Example of Holiday Period Screen

START-UP/SHUTDOWN/ RECYCLE SEQUENCE (FIG. 37)

Local Start-Up — Local start-up (or a manual start-up) is initiated by pressing the **[LOCAL]** menu softkey on the default ICVC screen. Local start-up can proceed when the chiller schedule indicates that the current time and date have been established as a run time and date, and after the internal 15-minute start-to-start and the 1-minute stop-to-start inhibit timers have expired. These timers are represented in the *START INHIBIT TIMER* and can be viewed on the MAINSTAT screen and DEFAULT screen. The timer must expire before the chiller will start. If the timers have not expired the *RUN STATUS* parameter on the MAINSTAT screen now reads TIMEOUT.

NOTE: The time schedule is said to be “occupied” if the *OCCUPIED?* parameter on the MAINSTAT screen is set to YES. For more information on occupancy schedules, see the sections on Time Schedule Operation (page 28), Occupancy Schedule (page 47), and To Prevent Accidental Start-Up (page 82), and Fig. 29.

If the *OCCUPIED?* parameter on the MAINSTAT screen is set to NO, the chiller can be forced to start as follows. From the default ICVC screen, press the **[MENU]** and **[STATUS]** softkeys. Scroll to highlight MAINSTAT. Press the **[SELECT]** softkey. Highlight and select *CHILLER START/STOP*. Press the **[START]** softkey to override the schedule and start the chiller.

NOTE: The chiller will continue to run until this forced start is released, regardless of the programmed schedule. To release

the forced start, highlight and select *CHILLER START/STOP* from the MAINSTAT screen and press the **[RELEASE]** softkey. This action returns the chiller to the start and stop times established by the schedule.

The chiller may also be started by overriding the time schedule. From the default screen, press the **[MENU]** and **[SCHEDULE]** softkeys. Scroll down and select the current schedule. Scroll down and select *OVERRIDE*, and set the desired override time period.

Another condition for start-up must be met for chillers that have the *REMOTE CONTACTS OPTION* on the EQUIPMENT SERVICE, OPTIONS screen set to ENABLE. For these chillers, the *REMOTE START CONTACT* parameter on the MAINSTAT screen must be CLOSED. From the ICVC default screen, press the **[MENU]** and **[STATUS]** softkeys. Scroll to high-light MAINSTAT and press the **[SELECT]** softkey. Scroll down the MAINSTAT screen to highlight *REMOTE START CONTACT* and press the **[SELECT]** softkey. Press the **[CLOSE]** softkey to initiate the override. To end the override, select *REMOTE START CONTACT* and press the **[RELEASE]** softkey.

Once local start-up begins, the PIC III performs a series of pre-start tests to verify that all pre-start alerts and safeties are within the limits shown in Table 5. The *RUN STATUS* parameter on the MAINSTAT screen line now reads PRESTART. If a test is not successful, the start-up is delayed or aborted. Failure to verify any of the requirements up to this point will result in the PIC III controls aborting the start and displaying the applicable pre-start alert on the ICVC default screen. A pre-start alert does not advance the starts in 12 hours counter. If the tests are successful, the chilled liquid pump relay energizes, and the MAINSTAT screen line now reads STARTUP.

Five seconds later, the condenser pump relay energizes. Thirty seconds later the PIC III module monitors the chilled liquid and condenser liquid flow devices and waits until the *LIQUID FLOW VERIFY TIME* (operator-configured, default 5 minutes) expires to confirm flow. After flow is verified, the chilled liquid temperature is compared to *CONTROL POINT* plus $1/2$ *CHILLED LIQUID DEADBAND*. If the temperature is less than or equal to this value, the PIC III controls turn off the condenser pump relay and goes into a RECYCLE mode.

NOTE: The 23XRV chillers are not available with factory-installed external chilled liquid flow or condenser liquid flow devices. These are available as an accessory for use with the CCM control board.

If the liquid temperature is high enough to require cooling, the start-up sequence continues. Tower fan control is enabled and the oil pump starts. Oil pressure is verified between 45 seconds and 5 minutes. The VFD is set to START following oil pressure verification and the controls verify that no faults exist. Proper compressor rotation is verified by monitoring the discharge pressure.

The control center monitors load current to verify that the compressor is running then steps the compressor up to target speed. The start-to-start and service ontime timers are activated when compressor operation is confirmed.

The controls will abort the start and display the applicable pre-start alert on the ICVC if any of the conditions above are not verified. Any fault after the start-up process is complete results in a safety shutdown, advancing the STARTS IN 12 HOURS counter by one, and display of the applicable shutdown status on the ICVC display.

Compressor ontime and service ontime timers start, and the compressor STARTS IN 12 HOURS counter in the MAIN-

STAT screen and the TOTAL COMPRESSOR STARTS counter advance by one.

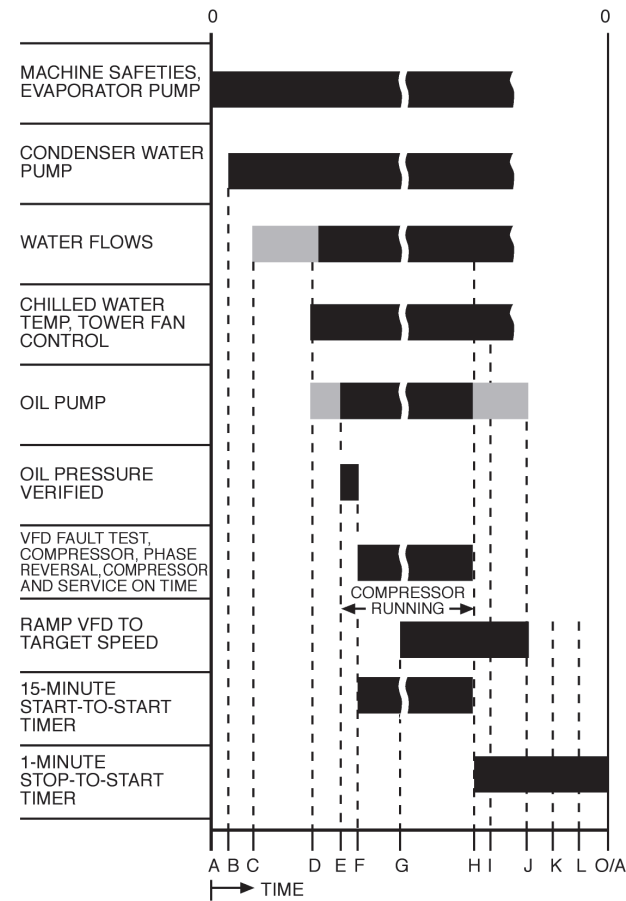

- A** — START INITIATED: Pre-start checks are made; chilled liquid pump started
- B** — Condenser liquid pump started (5 seconds after A)
- C** — Liquid flows verified (30 sec to 5 minutes maximum after B)
- D** — Chilled liquid temperature checked against control point; tower fan control enabled; oil pump on.
- E** — Oil pressure verified (oil pressure verified 45 to 300 sec after D.)
- F** — VFD starts; phase reversal conditions monitored; compressor on-time and service on-time start; 15-minute inhibit timer starts (VFD fault tests for 15 sec after "F")
- G** — Verify average current >5% within 15 sec after VFD start, ramp to VFD target speed.
- H** — Compressor reaches target speed, chiller set to running status
- I** — Ramp down until percent line current \leq soft stop amps threshold (0 to 60 sec after I)
- J** — Shutdown initiated: Target VFD speed to 0%. All load currents <5%.
- K** — Oil pump relay off (1 to 20 sec after J)
- L** — Evaporator pump deenergized (60 sec after K); condenser pump and tower fan control may continue to operate if condenser pressure is high; evaporator pump may continue if in RECYCLE mode or freeze protection alarm declared.
- O/A** — Restart permitted (both inhibit timers expired) (minimum of 15 minutes after F; minimum of 1 minute after L)

Fig. 37 — Control Sequence

Shutdown Sequence — Chiller shutdown begins if any of the following occurs:

- the STOP button is pressed for at least one second (the alarm light blinks once to confirm the stop command)
- a recycle condition is present (see Chilled Liquid Recycle Mode section)
- the time schedule has gone into unoccupied mode
- the chiller protective limit has been exceeded and chiller is in alarm
- the start/stop status is overridden to stop from the CCN network or the ICVC

When a stop signal occurs, the controls set *TARGET VFD SPEED* to 0. This will cause the compressor to reduce speed to the point where line amps equal the configured *SOFTSTOP AMPS THRESHOLD*. (In a recycle shutdown, the compressor will probably be at or below the soft stop threshold amps when the stop signal is received.) At that point, or one minute after the stop signal occurs (whichever is earlier), the VFD is set to STOP. If the STOP key is depressed a second time during the soft stop or within one minute of the stop signal occurring, the compressor is immediately stopped.

When the VFD is set to STOP, the compressor is turned off. The compressor shut down is confirmed by monitoring load amps. When the compressor shutdown is verified, the oil pump is turned off and VFD STOP is complete. After one minute, the chilled liquid pump is turned off, unless it is a recycle shutdown. At this point, the compressor on-time and service on-time timers are turned off, and the stop-to-start timer is turned on.

At this time the condenser liquid pump is also shut off, provided that the entering condenser liquid temperature is 115 F (6.1 C) or greater, and the condenser refrigerant temperature is greater than the condenser freeze point plus 5° F (3° C). Otherwise, it remains under the control of the Condenser Pump Control algorithm.

If the shut down is due to low evaporator refrigerant temperature, the chilled liquid pump continues to run until the leaving chilled liquid temperature is greater than the control point, plus 5° F (3° C).

Automatic Soft Stop Amps Threshold —

When a non-recycle, non-alarm shutdown is called for, the soft stop feature unloads the compressor by reducing speed to the point where load amps equal the *SOFTSTOP AMPS THRESHOLD*. The compressor is then turned off (see the above sequence).

If the chiller enters an alarm state or if the compressor enters a RECYCLE mode, the compressor de-energizes immediately.

To modify the soft stop amps threshold feature, scroll to the OPTIONS screen on the ICVC. Use the **[INCREASE]** or **[DECREASE]** softkey to set the *SOFTSTOP AMPS THRESHOLD* parameter to the percent of amps at which the motor will shut down. Setting *SOFT STOP AMPS THRESHOLD* to 100% de-activates this feature. The default setting is 100% amps (no soft stop). The range is 40 to 100%.

When the soft stop amps threshold feature is being applied, a status message, "SHUTDOWN IN PROGRESS, COMPRESSOR UNLOADING" displays on the ICVC.

The soft stop amps threshold function can be terminated and the compressor motor de-energized immediately by depressing the STOP button twice.

Chilled Liquid Recycle Mode — The chiller may cycle off and wait until the load increases to restart when the compressor is running in a lightly loaded condition. This cycling is normal and is known as “recycle.” A recycle shutdown is initiated when any of the following conditions are true:

1. *ECL CONTROL OPTION* is DISABLED (LCL control):

The *CONTROL POINT* has not been increased by at least 1° F (0.5° C) in the last 5 min. and *LEAVING CHILLED LIQUID* temperature is less than the *CONTROL POINT* (MAINSTAT screen) minus 5° F (3° C) (for units with P compressors, 5° F [3° C] is configurable with *RECYCLE SHUTDOWN DELTA T*); or *LEAVING CHILLED LIQUID* temperature is less than the *CONTROL POINT* and the *VFD TARGET SPEED* is less than the minimum speed plus *RECYCLE SHUTDOWN DELTA SPEED* and ice build is not active.

2. *ECL CONTROL OPTION* is ENABLED and ice build is not active (ECL control):

The *CONTROL POINT* has not been increased by at least 1° F in the last 5 min. and *ENTERING CHILLED LIQUID* temperature is less than the *CONTROL POINT* minus 5° F (3° C) (for units with P compressors, 5° F [3° C] is configurable with *RECYCLE SHUTDOWN DELTA T*) or *ENTERING CHILLED LIQUID* temperature is less than the *CONTROL POINT* and the *VFD TARGET SPEED* is less than the Minimum Speed plus *RECYCLE SHUTDOWN DELTA SPEED*.

3. The *LEAVING CHILLED LIQUID* temperature is less than the *EVAP REFRIG TRIPPOINT* plus 3° F (1.7° C). (NOTE: Refer to Refrigerant Low Temperature Override.)

Whenever recycle shutdown is active the RUN STATUS shall be “Recycle.”

When the chiller is in RECYCLE mode, the chilled liquid pump relay remains energized so the chilled liquid temperature can be monitored for increasing load. The recycle control uses *RECYCLE CONTROL RESTART DELTA T* to check when the compressor should be restarted. This is an operator-configured function which defaults to 5° F (3° C). This value can be viewed or modified on the SETUP1 table. The compressor will restart when the chiller is:

- in LCL CONTROL (*ECL CONTROL OPTION* DISABLED) and the *LEAVING CHILLED LIQUID* temperature is greater than the *CONTROL POINT* plus the *RECYCLE CONTROL RESTART DELTA T*.
- in ECL CONTROL and the *ENTERING CHILLED LIQUID* temperature is greater than the *CONTROL POINT* plus the *RECYCLE CONTROL RESTART DELTA T*.

Once these conditions are met, the compressor initiates a start-up with a normal start-up sequence.

An alert condition may be generated if 5 or more recycle start-ups occur in less than 4 hours. Excessive recycling can reduce chiller life; therefore, compressor recycling due to extremely low loads should be reduced.

To reduce compressor recycling, use the time schedule to shut the chiller down during known low load operation periods, or increase the chiller load by running the fan systems. If the hot gas bypass is installed, adjust the values to ensure that hot gas is energized during light load conditions. Increase the *RECYCLE CONTROL RESTART DELTA T* on the SETUP1 table to lengthen the time between restarts.

The chiller should not be operated below design minimum load without a hot gas bypass installed.

Safety Shutdown — A safety shutdown is identical to a manual shutdown with the exception that, during a safety shutdown, the ICVC displays the reason for the shutdown, the alarm light blinks continuously, and the spare alarm contacts are energized.

After a safety shutdown, the [RESET] softkey must be pressed to clear the alarm. If the alarm condition is still present, the alarm light continues to blink. Once the alarm is cleared, the operator must press the [CCN] or [LOCAL] softkeys to restart the chiller.

BEFORE INITIAL START-UP

Job Data Required

- list of applicable design temperatures and pressures (product data submittal)
- chiller certified prints
- starting equipment details and wiring diagrams
- diagrams and instructions for special controls or options
- 23XRV Installation Instructions
- pumpout unit instructions

Equipment Required

- T30 hexalobular socket screw driver to remove control center door shipping brackets
- mechanic’s tools (refrigeration)
- digital volt-ohmmeter (DVM)
- clamp-on ammeter
- electronic leak detector
- absolute pressure manometer or wet-bulb vacuum indicator (Fig. 38)
- 500-v insulation tester (megohmmeter) for compressor motors with nameplate voltage of 600 v or less
- Reliance LCD OIM (operator interface module) (optional)

Using the Optional Storage Tank and Pumpout System — Refer to Chillers with Storage Tanks section, page 87 for pumpout system preparation, refrigerant transfer, and chiller evacuation.

Remove Shipping Packaging — Remove any packaging material from the control center, oil pump, VFD cooling solenoid, HGBP solenoid, oil reclaim actuator, oil heater terminal boxes, and relief valves.

Open Oil Circuit Valves — Check to ensure the oil filter isolation valves (Fig. 14) are open by removing the valve cap and checking the valve stem.

Oil Charge — The oil charge for the 23XRV chiller is split between the cooler and the oil vaporizer:

FRAME SIZE	COOLER CHARGE	OIL SUMP CHARGE	TOTAL
A	1 gal.(3.8 L)	9.0 gal.(34.1 L)	10.0 gal. (37.9 L)
B			
3			
4			
5			

The chiller is shipped with its oil charge. The oil level in the vaporizer will initially be in the center of the oil sump sight glass. This level will vary depending on the amount of refrigerant that has been absorbed by the oil and the operating conditions of the chiller. Normal oil levels will vary from the top of the strainer housing sight glass to above the top of the oil sump sight glass.

If oil is added, it must conform to Carrier’s specification for screw compressor use as described in the Oil Specification section. Charge the oil through the oil charging valve located near the bottom of the oil strainer housing. The oil must be

pumped from the oil container through the charging valve due to the higher refrigerant pressure. The pumping device must be able to lift from 0 to 200 psig (1379 kPa) or above unit pressure. Oil should only be charged or removed when the chiller is shut down.

Tighten All Gasketed Joints — Gaskets normally relax by the time the chiller arrives at the jobsite. Tighten all gasketed joints to ensure a leak-tight chiller. See Tables 8 and 9 for waterbox torque specifications.

Table 8 — Bolt Torque Requirements, Foot Pounds

BOLT SIZE (in.)	SAE 2, A307 GR A HEX HEAD NO MARKS LOW CARBON STEEL		SAE 5 SOCKET HEAD OR HEX WITH 3 RADIAL LINES, OR SA499 MEDIUM CARBON STEEL		SAE 8 HEX HEAD WITH 6 RADIAL LINES OR SA354 GR BD MEDIUM CARBON STEEL	
	MINIMUM	MAXIMUM	MINIMUM	MAXIMUM	MINIMUM	MAXIMUM
1/4	4	6	6	9	9	13
5/16	8	11	13	18	20	28
3/8	13	19	22	31	32	46
7/16	21	30	35	50	53	75
1/2	32	45	53	75	80	115
9/16	46	65	75	110	115	165
5/8	65	95	105	150	160	225
3/4	105	150	175	250	260	370
7/8	140	200	265	380	415	590
1	210	300	410	580	625	893
1 1/8	330	475	545	780	985	1,410
1 1/4	460	660	770	1,100	1,380	1,960
1 3/8	620	885	1,020	1,460	1,840	2,630
1 1/2	740	1060	1,220	1,750	2,200	3,150
1 5/8	1010	1450	1,670	2,390	3,020	4,310
1 3/4	1320	1890	2,180	3,110	3,930	5,610
1 7/8	1630	2340	2,930	4,190	5,280	7,550
2	1900	2720	3,150	4,500	5,670	8,100
2 1/4	2180	3120	4,550	6,500	8,200	11,710
2 1/2	3070	4380	5,000	7,140	11,350	16,210
2 3/4	5120	7320	8,460	12,090	15,710	22,440
3	6620	9460	11,040	15,770	19,900	28,440

Table 9 — Bolt Torque Requirements, Foot Pounds (Metric Bolts)

BOLT SIZE (METRIC)	CLASS 8.8		CLASS 10.9	
	MINIMUM	MAXIMUM	MINIMUM	MAXIMUM
M4	1.75	2.5	2.5	3.5
M6	6	9	8	12
M8	14	20	20	30
M10	28	40	40	57
M12	48	70	70	100
M16	118	170	170	240
M20	230	330	330	470
M24	400	570	570	810
M27	580	830	820	1175

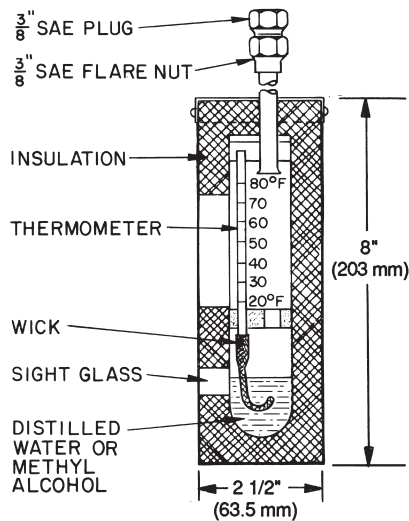

Fig. 38 — Typical Wet-Bulb Type Vacuum Indicator

Check Chiller Tightness — Figure 39 outlines the proper sequence and procedures for leak testing.

The 23XRV chillers are shipped with a full refrigerant and oil charge. Units may be ordered with the refrigerant shipped separately, and a 15 psig (103 kPa) nitrogen-holding charge in each vessel. To determine if there are any leaks, the chiller should be charged with a refrigerant tracer. Use an electronic leak detector to check all flanges and solder joints after the chiller is pressurized. If any leaks are detected, follow the leak test procedure.

If the chiller is spring isolated, keep all springs blocked in both directions to prevent possible piping stress and damage during the transfer of refrigerant from vessel to vessel during the leak test process, or any time refrigerant is being transferred. Adjust the springs when the refrigerant is in operating condition and the liquid circuits are full.

Refrigerant Tracer — Carrier recommends the use of an environmentally acceptable refrigerant tracer for leak testing with an electronic detector or halide torch.

Ultrasonic leak detectors can also be used if the chiller is under pressure.

⚠ WARNING

Do not use air or oxygen as a means of pressurizing the chiller. Mixtures of HFC-134a and air can undergo combustion.

Leak Test Chiller — Due to regulations regarding refrigerant emissions and the difficulties associated with separating contaminants from refrigerant, Carrier recommends the following leak test procedures. See Fig. 39 for an outline of the leak test procedures. Refer to Fig. 40-43 during pumpout procedures. See the Pumpout and Refrigerant Transfer Procedures section on page 86. Refer to Tables 10 and 11 for temperature/pressure relationships for HFC-134a refrigerant.

1. If the pressure readings are normal for chiller condition:
 - a. Evacuate the holding charge from the vessels, if present.
 - b. Raise the chiller pressure, if necessary, by adding refrigerant until pressure is at equivalent saturated pressure for the surrounding temperature.

⚠ WARNING

Never charge liquid refrigerant into the chiller if the pressure in the chiller is less than 35 psig (241 kPa). Charge as a gas only, with the cooler and condenser pumps running, until this pressure is reached, using PUMPDOWN and TERMINATE PUMPDOWN MODE on the ICVC. Flashing of liquid refrigerant at low pressures can cause tube freeze-up and considerable damage.

- c. Leak test chiller as outlined in Steps 3-7.
2. If the pressure readings are abnormal for chiller condition:
 - a. Prepare to leak test chillers shipped with refrigerant. If chiller is shipped with refrigerant, proceed to Step 3.
 - b. Check for large leaks by connecting a nitrogen bottle and raising the pressure to 30 psig (207 kPa). Soap test all joints. If the test pressure holds for 30 minutes, prepare the test for small leaks (Steps 2g to 2h).
 - c. Plainly mark any leaks which are found.
 - d. Release the pressure in the system.
 - e. Repair all leaks.
 - f. Retest only those joints that were repaired.
 - g. After successfully completing the test for large leaks, remove as much nitrogen, air, and moisture as possible, given the fact that small leaks may be present in the system. This can be accomplished by following the dehydration procedure, outlined in the Chiller Dehydration section, page 71.
 - h. Slowly raise the system pressure to normal operating pressures for the refrigerant used in the chiller. Proceed with the test for small leaks (Steps 3 to 7).
3. Check the chiller carefully with an electronic leak detector or halide torch.
4. Leak Determination — If an electronic leak detector indicates a leak, use a soap bubble solution, if possible, to confirm. Total all leak rates for the entire chiller. Leakage at rates greater than 1 lb/year (0.45 kg/year) for the entire chiller must be repaired. Note total chiller leak rate on the start-up report.
5. If no leak is found during initial start-up procedures, complete the transfer of refrigerant gas from the storage tank to the chiller. Retest for leaks.
6. If no leak is found after a retest
 - a. Transfer the refrigerant to the storage tank and perform a standing vacuum test as outlined in the Chiller Dehydration section, page 71.
 - b. If the chiller fails this test, check for large leaks (Step 2b).
 - c. Dehydrate the chiller if it passes the standing vacuum test. Follow the procedure in the Chiller Dehydration section, page 71. Charge chiller with refrigerant.
7. If a leak is found, pump the refrigerant back into the storage tank, or if isolation valves are present, pump into the vessel that is not leaking.

Transfer the refrigerant until chiller pressure is at least equal to the pressure specified by the EPA under 40 CFR Part 82.

Repair the leak and repeat the procedure, beginning from Step 2h to ensure a leaktight repair. If chiller is opened to the atmosphere for an extended period, evacuate it before repeating leak test.

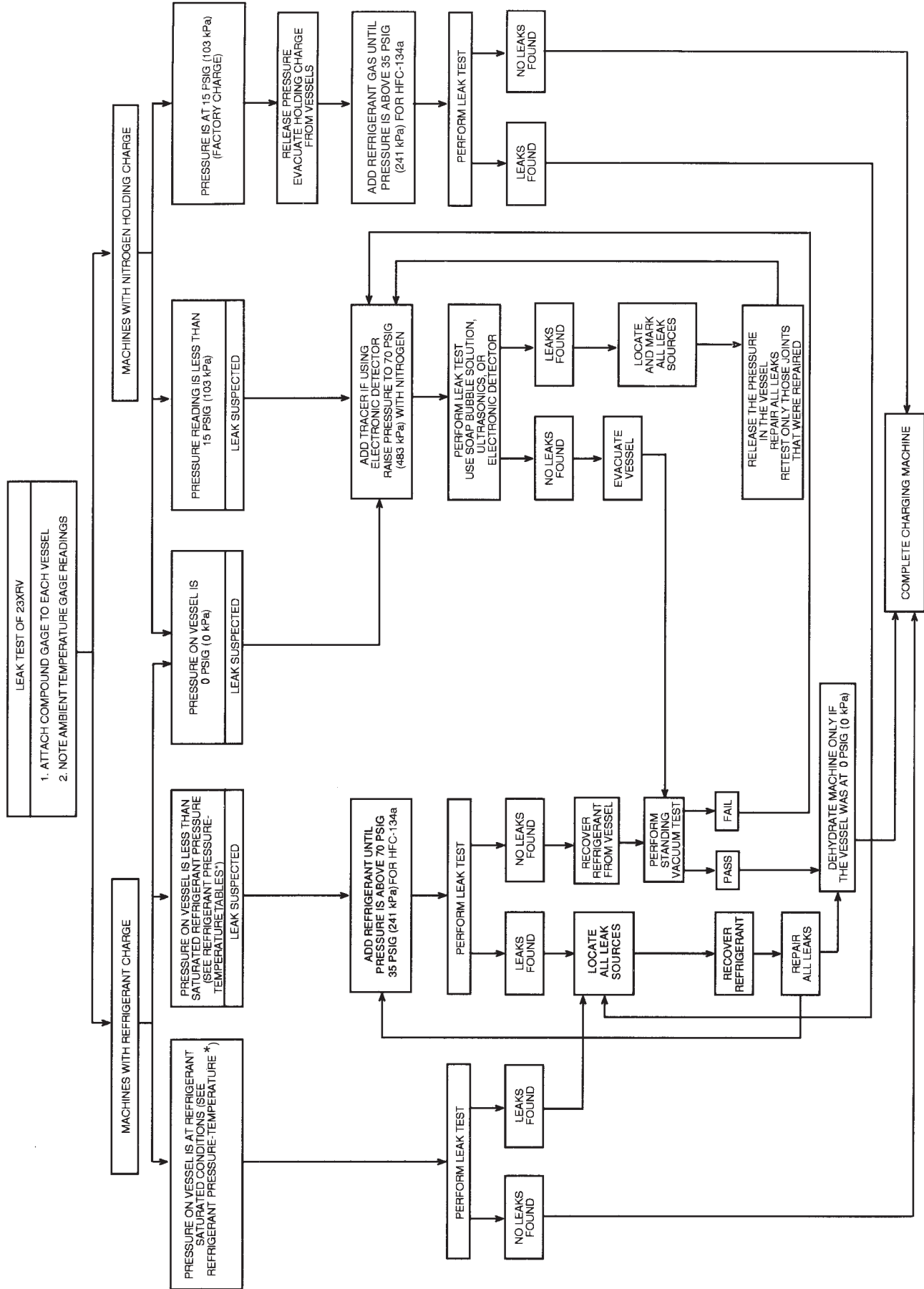
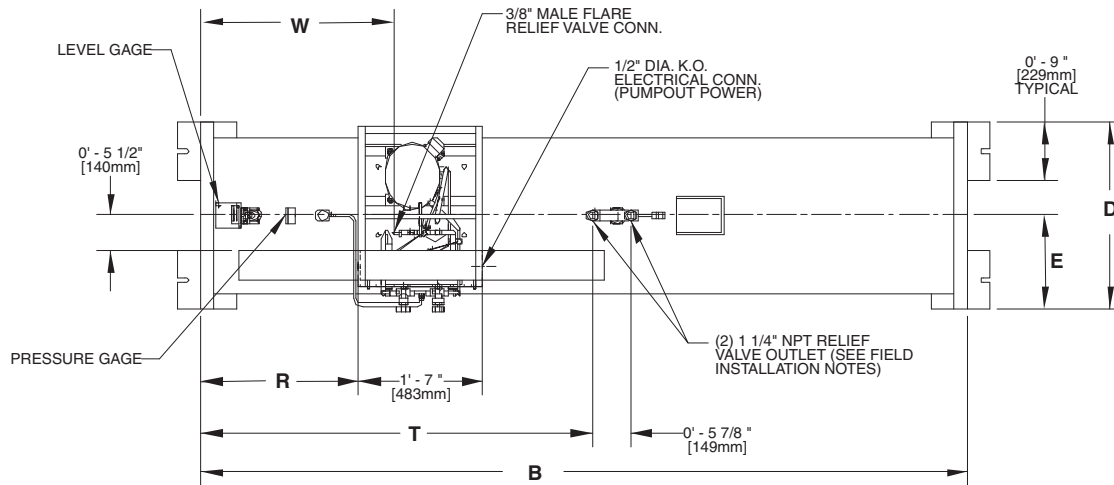
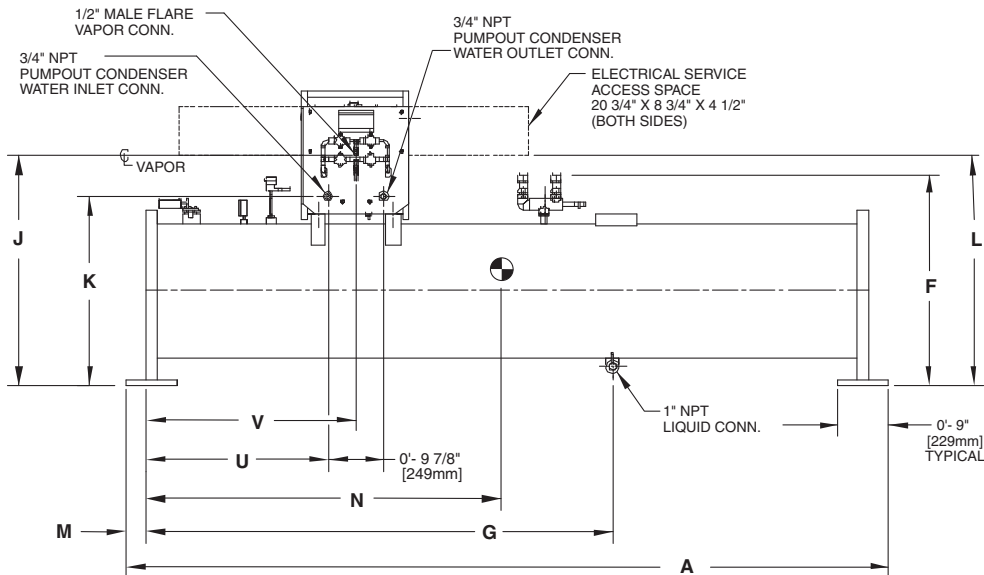

Fig. 39 — 23XRV Leak Test Procedure

*See Tables 10 and 11.



TOP VIEW



FRONT VIEW

NOTES:

1. Denotes center of gravity.
2. Dimensions in [] are in millimeters.
3. The weights and center of gravity values given are for an empty storage tank.
4. For additional information on the pumpout unit, see certified drawings.
5. Conduit knockout is located on the side of the control box.
6. 28 cubic ft storage tank weight: 2334 lb (1059 kg).
7. 52 cu ft storage tank weight: 3414 lb (1549 kg).

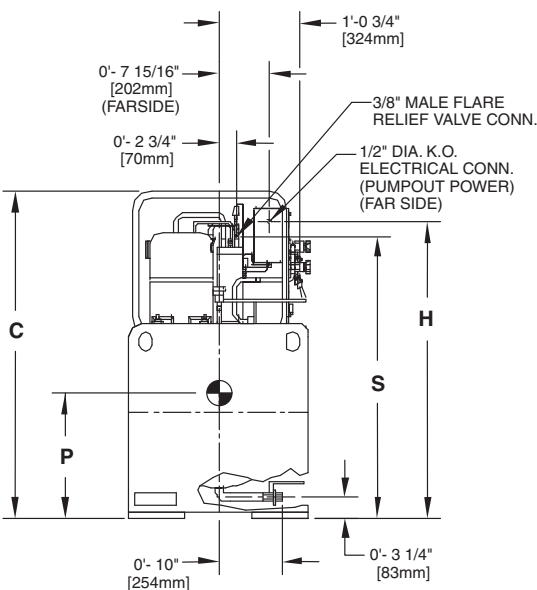

LEFT SIDE VIEW

DIMENSIONS
ENGLISH (ft.-in.)

TANK SIZE	A	B	C	D	E	F	G	H	J	K
0428	10- 5	9-10	4-4 ¹ / ₄	2-4 ³ / ₄	1-2 ³ / ₈	3-1 ¹ / ₄	6-4 ³ / ₁₆	3-11 ³ / ₈	3-4 ⁷ / ₈	2-9 ⁹ / ₁₆
0452	14-11 ¹ / ₄	14- 4 ¹ / ₂	4-8 ¹ / ₄	2-8 ¹ / ₂	1-4 ¹ / ₄	3-4 ¹ / ₂	7-2 ¹ / ₄	4- 3 ¹ / ₄	3-8 ³ / ₄	3-17 ¹ / ₁₆

TANK SIZE	L	M	N	P	R	S	T	U	V	W
0428	3-4 ⁵ / ₈	0-3 ¹ / ₂	4- 9 ¹ / ₂	1-7 ⁷ / ₈	2-0 ³ / ₈	3-9	5-0 ¹ / ₄	2-5	2-9 ⁷ / ₈	2-5 ³ / ₄
0452	3-8 ¹ / ₂	0-3 ³ / ₈	6-11 ⁵ / ₈	1-8 ³ / ₄	2-0 ⁵ / ₈	4-1	5-0 ¹ / ₂	2-5 ¹ / ₄	2-10 ¹ / ₈	2-6

SI (mm)

TANK SIZE	A	B	C	D	E	F	G	H	J	K
0428	3175	2997	1327	730	365	946	1935	1203	1038	852
0452	4553	4381	1429	826	413	1029	2191	1302	1137	951

TANK SIZE	L	M	N	P	R	S	T	U	V	W
0428	1032	89	1451	505	619	1143	1530	737	860	756
0452	1130	86	2124	527	625	1225	1537	742	867	762

Fig. 40 — Optional Pumpout Unit and Storage Tank (Unit with R Compressor Shown)

RATED DRY WEIGHT AND REFRIGERANT CAPACITY

ENGLISH (lb)

TANK SIZE	TANK OD (in.)	DRY WEIGHT* (lb)	R-134A MAXIMUM REFRIGERANT CAPACITY (lb)	
			ANSI/ASHRAE 15	UL 1963
0428	24.00	2334	1860	1716
0452	27.25	3414	3563	3286

SI (kg)

TANK SIZE	TANK OD (mm)	DRY WEIGHT* (kg)	R-134A MAXIMUM REFRIGERANT CAPACITY (kg)	
			ANSI/ASHRAE 15	UL 1963
0428	610	1059	844	778
0452	692	1549	1616	1491

LEGEND

- ANSI — American National Standard Institute
- ASHRAE — American Society of Heating, Refrigeration, and Air-Conditioning Engineers
- OD — Outside Diameter
- UL — Underwriters Laboratories

*The above dry weight includes the pumpout condensing unit weight of 164 lb (75 kg).

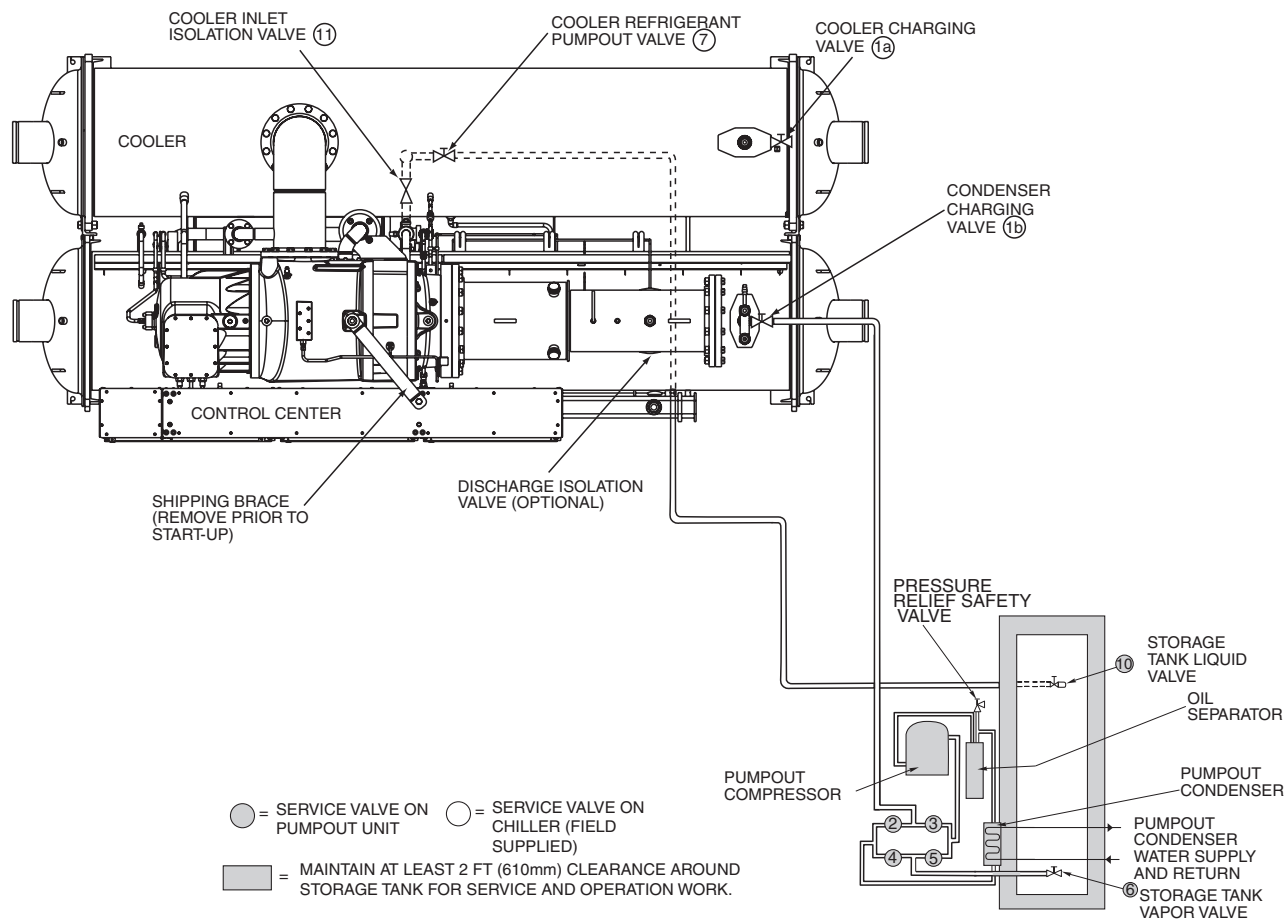

Fig. 41 — Optional Pumpout System Piping Schematic with Storage Tank — Configured to Push Liquid into Storage Tank (Unit with R Compressor Shown)

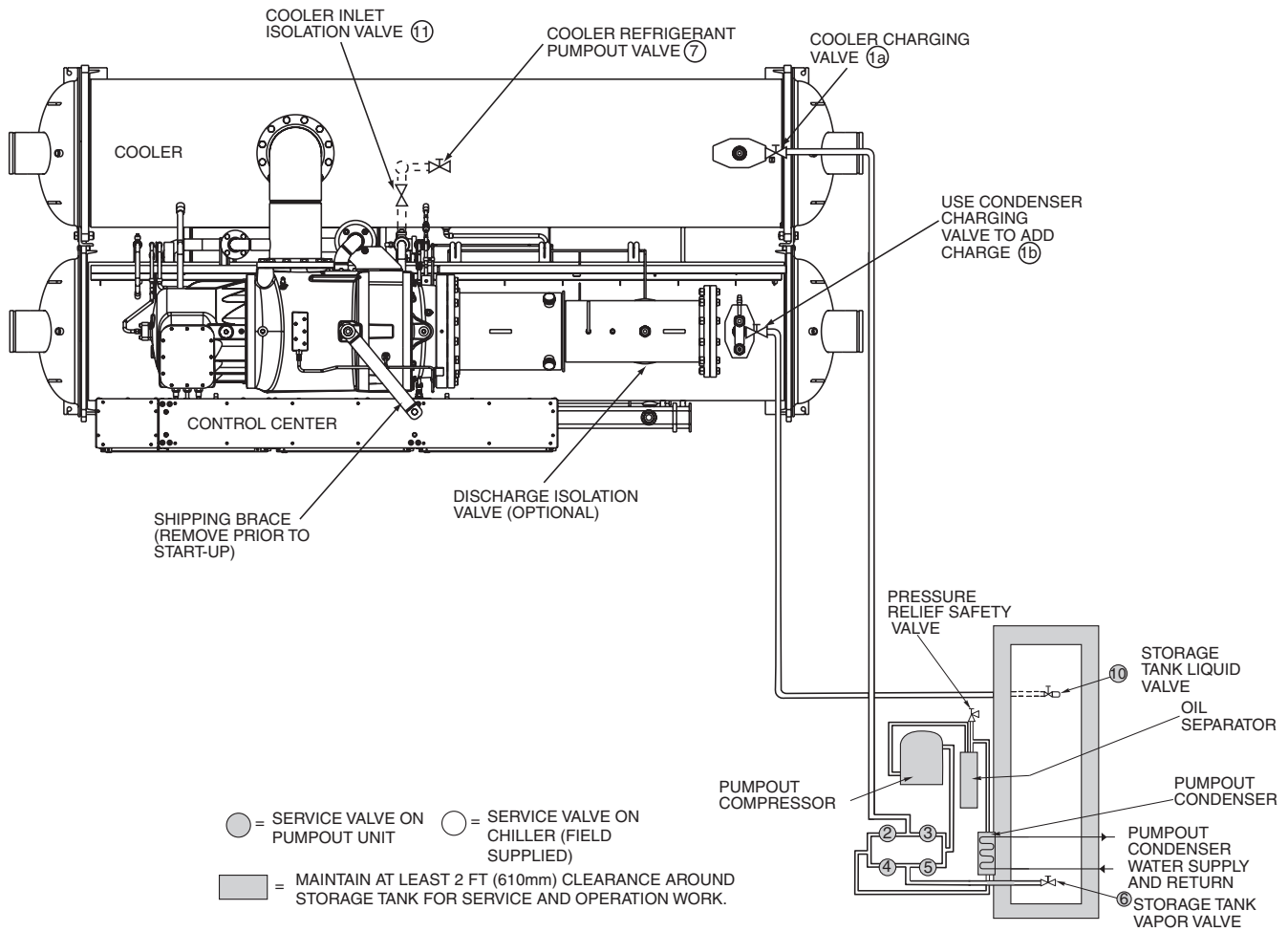

Fig. 42 — Optional Pumpout System Piping Schematic with Storage Tank — Configured to Pull Vapor out of Chiller or to Charge Chiller from Storage Tank (Unit with R Compressor Shown)

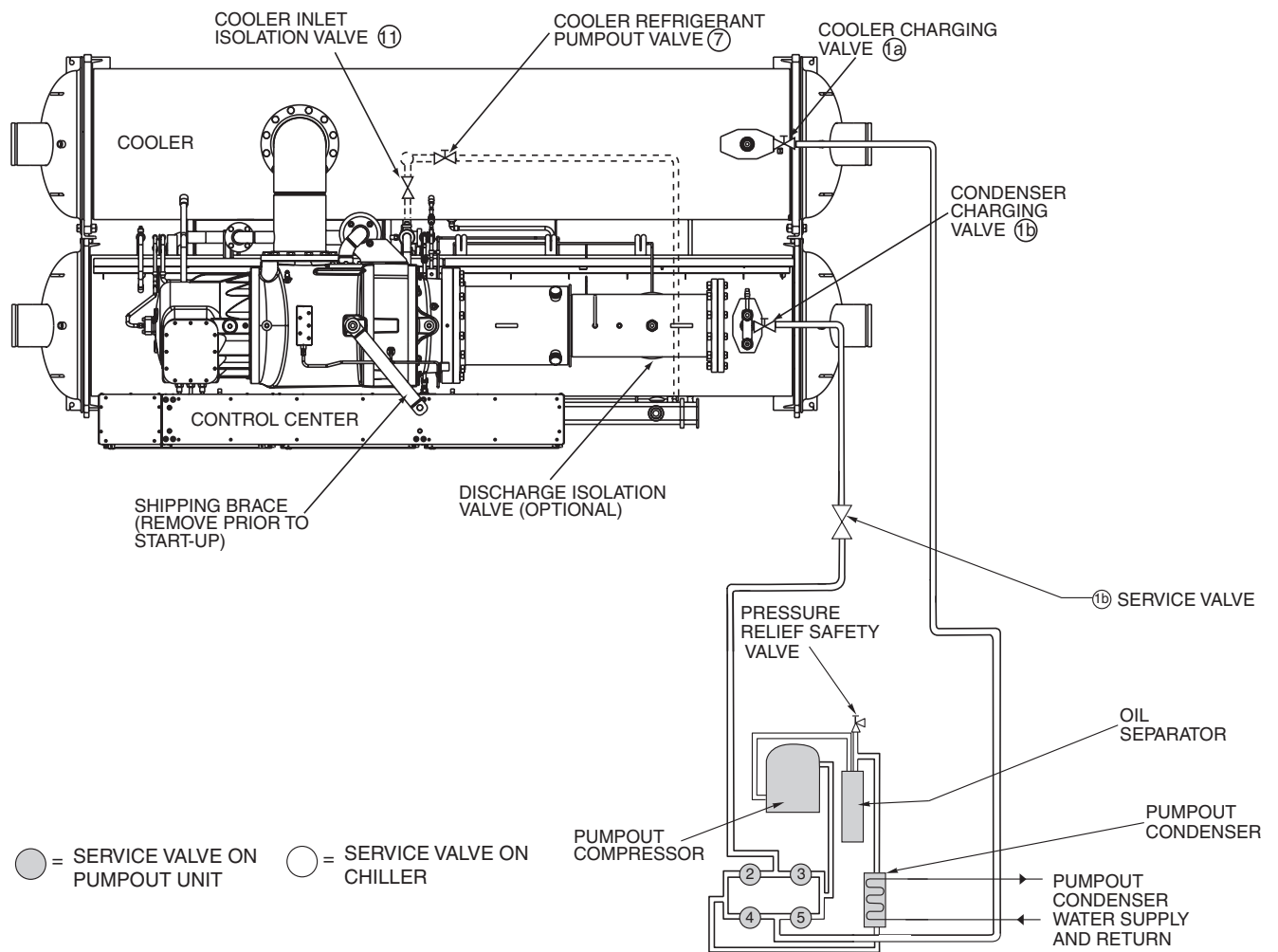

Fig. 43 — Optional Pumpout System Piping Schematic without Storage Tank — Configured to Store Refrigerant in Cooler or Condenser (Unit with R Compressor Shown)

Table 10 — HFC-134a Pressure — Temperature (F)

TEMPERATURE (F)	PRESSURE (psig)
0	6.50
2	7.52
4	8.60
6	9.66
8	10.79
10	11.96
12	13.17
14	14.42
16	15.72
18	17.06
20	18.45
22	19.88
24	21.37
26	22.90
28	24.48
30	26.11
32	27.80
34	29.53
36	31.32
38	33.17
40	35.08
42	37.04
44	39.06
46	41.14
48	43.28
50	45.48
52	47.74
54	50.07
56	52.47
58	54.93
60	57.46
62	60.06
64	62.73
66	65.47
68	68.29
70	71.18
72	74.14
74	77.18
76	80.30
78	83.49
80	86.17
82	90.13
84	93.57
86	97.09
88	100.70
90	104.40
92	108.18
94	112.06
96	116.02
98	120.08
100	124.23
102	128.47
104	132.81
106	137.25
108	141.79
110	146.43
112	151.17
114	156.01
116	160.96
118	166.01
120	171.17
122	176.45
124	181.83
126	187.32
128	192.93
130	198.66
132	204.50
134	210.47
136	216.55
138	222.76
140	229.09

Table 11 — HFC-134a Pressure — Temperature (C)

TEMPERATURE (C)	PRESSURE (kPa)
-18.0	44.8
-16.7	51.9
-15.6	59.3
-14.4	66.6
-13.3	74.4
-12.2	82.5
-11.1	90.8
-10.0	99.4
-8.9	108.0
-7.8	118.0
-6.7	127.0
-5.6	137.0
-4.4	147.0
-3.3	158.0
-2.2	169.0
-1.1	180.0
0.0	192.0
1.1	204.0
2.2	216.0
3.3	229.0
4.4	242.0
5.0	248.0
5.6	255.0
6.1	261.0
6.7	269.0
7.2	276.0
7.8	284.0
8.3	290.0
8.9	298.0
9.4	305.0
10.0	314.0
11.1	329.0
12.2	345.0
13.3	362.0
14.4	379.0
15.6	396.0
16.7	414.0
17.8	433.0
18.9	451.0
20.0	471.0
21.1	491.0
22.2	511.0
23.3	532.0
24.4	554.0
25.6	576.0
26.7	598.0
27.8	621.0
28.9	645.0
30.0	669.0
31.1	694.0
32.2	720.0
33.3	746.0
34.4	773.0
35.6	800.0
36.7	828.0
37.8	857.0
38.9	886.0
40.0	916.0
41.1	946.0
42.2	978.0
43.3	1010.0
44.4	1042.0
45.6	1076.0
46.7	1110.0
47.8	1145.0
48.9	1180.0
50.0	1217.0
51.1	1254.0
52.2	1292.0
53.3	1330.0
54.4	1370.0
55.6	1410.0
56.7	1451.0
57.8	1493.0
58.9	1536.0
60.0	1580.0

Chiller Dehydration — Dehydration is recommended if the chiller has been open for a considerable period of time, if the chiller is known to contain moisture, or if there has been a complete loss of chiller holding charge or refrigerant pressure.

⚠ CAUTION

Do not start or megohm-test the compressor motor, even for a rotation check, if the chiller is under dehydration vacuum. Insulation breakdown and severe damage may result.

Dehydration can be done at room temperatures. Using a cold trap (Fig. 44) may substantially reduce the time required to complete the dehydration. The higher the room temperature, the faster dehydration takes place. At low room temperatures, a very deep vacuum is required to boil off any moisture. If low ambient temperatures are involved, contact a qualified service representative for the dehydration techniques required.

Perform dehydration as follows:

1. Disconnect power from the VFD before placing the chiller under a vacuum.
2. Connect a high capacity vacuum pump (5 cfm [.002 m³/s] or larger is recommended) to the cooler or condenser charging valve (Fig. 2-4). Tubing from the pump to the chiller should be as short in length and as large in diameter as possible to provide least resistance to gas flow.
3. Use an absolute pressure manometer or a wet bulb vacuum indicator to measure the vacuum. Open the shutoff valve to the vacuum indicator only when taking a reading. Leave the valve open for 3 minutes to allow the indicator vacuum to equalize with the chiller vacuum.
4. If the entire chiller is to be dehydrated, open all isolation valves (if present).
5. With the chiller ambient temperature at 60 F (15.6 C) or higher, operate the vacuum pump until the manometer reads 29.9 in. Hg vacuum (750 microns), 0.1 kPa, or a vacuum indicator reads 35 F (1.7 C). Operate the pump an additional 2 hours.

Do not apply a greater vacuum than 29.82 in. Hg vac (757.4 mm Hg) or go below 33 F (0.56 C) on the wet bulb vacuum indicator. At this temperature and pressure, isolated pockets of moisture can turn into ice. The slow rate of evaporation (sublimation) of ice at these low temperatures and pressures greatly increases dehydration time.

6. Valve off the vacuum pump, stop the pump, and record the instrument reading.
7. After a 2-hour wait, take another instrument reading. If the reading has not changed, dehydration is complete. If the reading indicates vacuum loss, repeat Steps 4 and 5. Final dehydration vacuum should be 29.9 in. Hg vac or less [500 microns, 0.07 kPa (abs)].

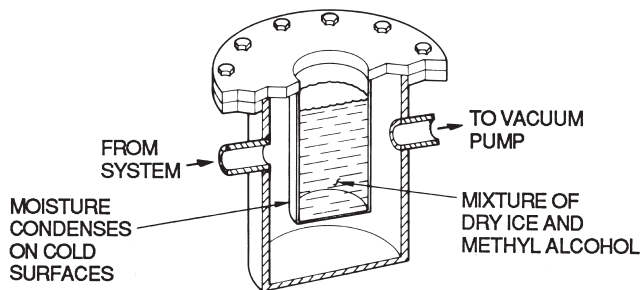

Fig. 44 — Dehydration Cold Trap

8. If the reading continues to change after several attempts, perform a leak test up to the maximum 160 psig (1103 kPa) pressure. Locate and repair the leak, and repeat dehydration.

Inspect Liquid Piping — Refer to piping diagrams provided in the certified drawings and the piping instructions in the 23XRV Installation Instructions manual. Inspect the piping to the cooler and condenser. Be sure that the flow directions are correct and that all piping specifications have been met.

Piping systems must be properly vented with no stress on waterbox nozzles and covers. Liquid flows through the cooler and condenser must meet job requirements. Measure the pressure drop across the cooler and the condenser.

⚠ CAUTION

Liquid must be clean and treated to ensure proper chiller performance and to reduce the potential of tube damage due to corrosion, scaling, or erosion. Carrier assumes no responsibility for chiller damage resulting from untreated or improperly treated cooler or condenser liquid.

Inspect Refrigerant Cooling Lines (Q,R Compressors Only) — Inspect the refrigerant cooling lines for condensation using an infrared temperature sensor or temperature meter.

The leaving refrigerant cooling line from the drive should have a temperature of 95 to 100 F (35 to 38 C) or a temperature that is 3 to 5° F (2 to 3° C) greater than the condenser refrigerant temperature. If the leaving refrigerant temperature is colder than these levels, or if condensation is noted on the power module or refrigerant cooling lines, the isolation valve on the leaving refrigerant cooling line should be partially closed (typically about half closed) to help with temperature regulation. See Fig. 45. Note that the adjustment is more accurate at a greater load that is fixed for at least 10 minutes, and there should be no condensation on the tube leaving the power module before the orifice.

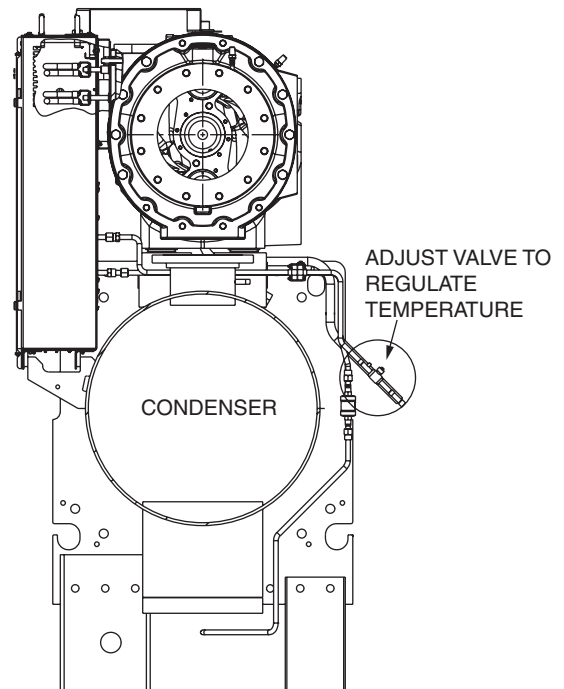

Fig. 45 — Isolation Valve, Leaving Refrigerant Cooling Line

Check Optional Pumpout Compressor Liquid Piping — If the optional pumpout storage tank and/or pumpout system are installed, check to ensure the pumpout condenser liquid has been piped in. Check for field-supplied shutoff valves and controls as specified in the job data. Check for refrigerant leaks on field-installed piping. See Fig. 40-43.

Check Relief Valves — Be sure the relief valves have been piped to the outdoors in compliance with the latest edition of ANSI/ASHRAE Standard 15 and applicable local safety codes. Piping connections must allow for access to the valve mechanism for periodic inspection and leak testing.

The 23XRV relief valves are set to relieve at the 185 psig (1276 kPa) chiller design pressure.

Identify the VFD — The LiquiFlo™ 2.0 AC drive is a PWM (Pulse Width Modulated), liquid-cooled drive that provides vector and general purpose regulation for a wide range of applications. Identify the drive from the Drive Part Number on the drive's nameplate and the model number matrix in Fig. 46 and 47.

⚠ WARNING

DC bus capacitors retain hazardous voltage after input power has been disconnected. After disconnecting input power, wait 5 minutes for the DC bus capacitors to discharge and then check the voltage with a voltmeter to ensure the DC capacitors are completely discharged before touching any internal components. Failure to observe this precaution could result in severe bodily injury or loss of life.

⚠ WARNING

The drive can operate at and maintain zero speed. The user is responsible for assuring safe conditions for operating personnel by providing suitable guards, audible or visual alarms, or other devices to indicate that the drive is operating or may operate at zero speed. Failure to observe this precaution could result in severe bodily injury or loss of life.

⚠ CAUTION

The drive contains ESD (Electrostatic Discharge) sensitive parts and assemblies. Static control precautions are required when installing, testing, servicing, or repairing the drive. Erratic machine operation and damage to, or destruction of equipment can result if this procedure is not followed.

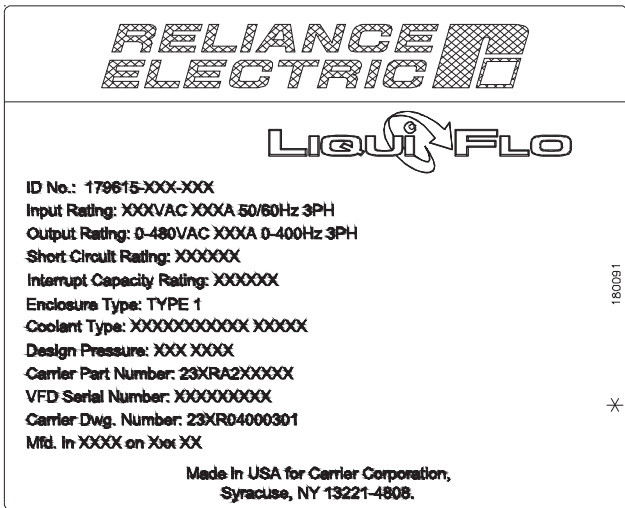

Fig. 46 — VFD Nameplate

The control center is designed to operate in the following environmental conditions:

CONDITION	SPECIFICATION
AMBIENT TEMPERATURE (OUTSIDE NEMA 1 ENCLOSURE)	32 to 122 F (0° to 50 C)
STORAGE TEMPERATURE (AMBIENT)	-40 to 149 F (-40 to 65 C)
HUMIDITY	5% to 95% (non-condensing)

LIQUI FLO **RA** US

MODEL # LF200608CCR

	KVA	VOLTS	A	PH	HZ
AC INPUT	505	346-480	608	3	50/60
AC OUTPUT	505	0-480	608	3	0-250

SHORT CIRCUIT RATING: 100,000 A RMS SYM

ENCLOSURE TYPE: OPEN CHASSIS
 COOLANT TYPE: R134a
 DESIGN PRESSURE: 185 PSIG

RELIANCE ELECTRIC Mfd. in 2005 on Apr 08
 Made in U.S.A. (FAC. 1C)

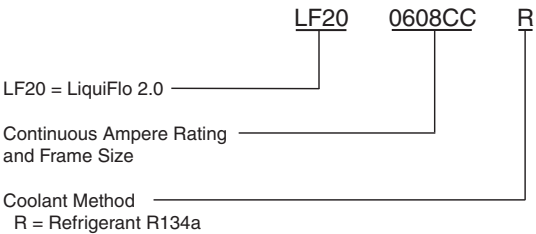

Fig. 47 — Identifying the Drive Model Number

IDENTIFYING THE DRIVE BY PART NUMBER — Each AC drive can be identified by its assembly number. See Fig. 47. This number appears on the shipping label and on the drive's nameplate. LiquiFlo 2.0 AC drives comprise an input components section and a power module section.

Each LiquiFlo™ 2.0 AC power module can be identified by its model number. See Fig. 47. This number appears on the shipping label and on the power module's nameplate. Power ratings for LF-2 VFDs are provided in Table 12. Power ratings for Std Tier VFDs are provided in Table 13.

Check Control Center

⚠ CAUTION

BE AWARE that certain automatic start arrangements *can engage the VFD*. Open the disconnect *ahead* of the control center in addition to shutting off the chiller or pump to avoid equipment damage and possible personal injury.

⚠ CAUTION

The main disconnect on the control center may not de-energize all internal circuits. Open all internal and remote disconnects before servicing the starter to avoid equipment damage and possible personal injury.

Input Power Wiring — All wiring should be installed in conformance with applicable local, national, and international codes. Use grommets, when hubs are not provided, to guard against wire chafing.

Use the following steps to connect AC input power to the main input circuit breaker and ground leads to the ground lug.

1. Turn off, lockout, and tag the input power to the drive.
2. Remove the input power wiring panel from the top of the control center and drill the required number of openings in the input power wiring panel. Take care that metal chips do not enter the VFD enclosure.

3. Wire the AC input power leads and ground leads by routing them through the opening in the top of the control center to the main input circuit breaker.

⚠ CAUTION

Do not route control wiring carrying 30 v or less within a conduit carrying 50 v or higher. Failure to observe this precaution could result in electromagnetic interference in the control wiring.

4. Connect the three-phase AC input power leads (per job specification) to the appropriate input terminals of the circuit breaker.
5. Tighten the AC input power terminals and lugs to the proper torque as specified on the input circuit breaker.
6. Connect and tighten the ground leads to the ground lug.

Checking the Installation — Use the following instructions to verify the condition of the installation:

1. Turn off, lockout, and tag the input power to the drive. Wait a minimum of 5 minutes for the DC bus to discharge.
2. Verify that there is no voltage at the input terminals (L1, L2 and L3) of the power module or main circuit breaker.
3. Verify that the status LEDs on the DPI communications interface board are not lit. The location of the DPI communications interface board is shown in Fig. 20.
4. Remove any debris, such as metal shavings, from the enclosure.
5. Check that there is adequate clearance around the machine.
6. Verify that the wiring to the terminal strip and the AC input power terminals is correct. Verify that all of the VFD power module circuit board connectors are fully engaged and secured in place.

Table 12 — Drive Assembly and Power Module Ratings (LF-2 VFD)

CARRIER PART NUMBER	FRAME SIZE	ENCLOSURE TYPE	INPUT VOLTAGE (V) RANGE	MAX INPUT CURRENT (AMPS)	MAX OUTPUT CURRENT* AT 4kHz (AMPS)
23XRA2AA	Frame 2AA	NEMA 1	380 to 460	440	442
23XRA2BA	Frame 2BA	NEMA 1	380 to 460	520	442
23XRA2BB	Frame 2BB	NEMA 1	380 to 460	520	520
23XRA2CC	Frame 2CC	NEMA 1	380 to 460	608	608

*110% output current capability for one minute, 150% output current for 5 seconds.

Table 13 — Drive Assembly and Power Module Ratings (Std Tier VFD)*

CARRIER PART NUMBER	ENCLOSURE TYPE	INPUT VOLTAGE (DIGIT Y OF PART NUMBER)		MAX INPUT CURRENT (AMPS)	MAX OUTPUT CURRENT† AT 2kHz (AMPS)
		Y	VOLTAGE/Hz		
23XVR0__00Y__F0** (R = ROCKWELL)	NEMA 1	3	380 v / 50 Hz	230	230
		4	416 v / 60 Hz	269	269
		5	460 v / 60 Hz	335	335
		7	575 v / 60 Hz	445	445
23XVE0__00Y__F0** (E = EATON)	NEMA 1	9	400 v / 50 Hz	485	485
				550	550
				605	605

*All voltage and current combinations listed may not be available for sale. Please review Carrier Marketing literature for latest offering.

†110% output current capability for one minute, 150% output current for 5 seconds.

** Last character 0 indicates refrigerant-cooled; last digit A indicates air-cooled.

7. Check that the wire size is within terminal specifications and that the wires are tightened properly.
8. Check that specified branch circuit protection is installed and correctly rated.
9. Check that the incoming power is within $\pm 10\%$ of chiller nameplate voltage.
10. All wiring should be installed in conformance with the applicable local, national, and international codes (for example, NEC/CEC). Verify that a properly sized ground wire is installed and a suitable earth ground is used. Check for and eliminate any grounds between the power leads. Verify that all ground leads are unbroken.

Inspect Wiring

⚠ WARNING

Do not check the voltage supply without proper equipment and precautions. Serious injury may result. Follow power company recommendations.

⚠ CAUTION

Do not apply any kind of test voltage, even for a rotation check, if the chiller is under a dehydration vacuum. Insulation breakdown and serious damage may result.

1. Examine the wiring for conformance to the job wiring diagrams and all applicable electrical codes. Confirm that there is at least a 6-in. clearance surrounding the control center louvers. Use an inspection mirror to visually inspect the top of the power module to confirm that no debris has fallen inside of it.
2. Connect a voltmeter across the power wires to the VFD and measure the phase to phase and phase to ground voltage. Compare this reading to the voltage rating on the compressor and starter nameplates.
3. Compare the ampere ratings on the Machine Electrical Data Nameplate. LOCKED ROTOR AMPS should be equal to RATED LINE AMPS. OVERLOAD TRIP AMPS should be equal to $1.08 \times$ RATED LINE AMPS.
4. The control center must be wired to components and terminals required for PIC III refrigeration control. Check line side power and for control components shown on the Certified Prints. The control center must share control of cooler and condenser liquid pumps and cooling tower fans.
5. Check the phase to phase and phase to ground line voltage to the optional pumpout compressor. Compare voltages against nameplate values. Refer to Fig. 48.
6. Ensure that fused disconnects or circuit breakers have been supplied to the control center and optional pumpout unit.
7. Ensure all electrical equipment and controls are properly grounded in accordance with the job drawings, certified drawings, and all applicable electrical codes.
8. Ensure the customer's contractor has verified proper operation of the pumps, cooling tower fans, and associated auxiliary equipment. This includes ensuring motors are properly lubricated and have proper electrical supply and proper rotation.
9. Tighten all wiring connections on the high and low voltage terminal blocks in the control center enclosure above and below the control panel.
10. Inspect the control panel in the control center enclosure to ensure that the contractor has used the knockouts to feed the wires into the back of the control panel. Wiring through the top of the control center can cause debris to

fall into the power module. Clean and inspect the interior of the control center if this has occurred. Contact Carrier Service before applying power if debris may have fallen inside of the power module.

Carrier A United Technologies Company	
MODEL NUMBER	
SERIAL NUMBER	
MACHINE NAMEPLATE SUPPLY DATA	
VOLTS/PHASE/HERTZ	
LOCKED ROTOR AMPS	
OVERLOAD TRIP AMPS	
MAX FUSE/CIRCUIT BREAKER SIZE	
MIN SUPPLY CIRCUIT AMPACITY	
MACHINE ELECTRICAL DATA	
MOTOR NAMEPLATE VOLTAGE	480V
COMPRESSOR 100% SPEED	
RATED LINE VOLTAGE	
RATED LINE AMPS	
RATED LINE KILOWATTS	
MOTOR RATED LOAD KW	
MOTOR RATED LOAD AMPS	
MOTOR NAMEPLATE AMPS	
MOTOR NAMEPLATE RPM	
MOTOR NAMEPLATE KW	
INVERTER PWM FREQUENCY	
CONTROLS, OIL PUMP AND HEATER DATA	
CONTROLS, OIL PUMP AND HEATER CIRCUIT	115V
MAX FUSE SIZE	15A
MIN CIRCUIT AMPACITY	15A
OIL PUMP	115V, 1.48A
OIL SUMP HEATER	115V, 4.35A, 500W
OIL VAPORIZER HTR CIRCUIT	115V
MAX FUSE SIZE	15A
MIN CIRCUIT AMPACITY	15A
OIL VAPORIZER HEATER	115V, 13.04A, 1500W
CARRIER CHARLOTTE 9701 OLD STATESVILLE ROAD CHARLOTTE, NORTH CAROLINA 28269 PRODUCTION YEAR 20XX 23XR05003001 REV. 4.0	

Fig. 48 — Machine Electrical Data Nameplate (Q,R Compressor Machine Label Shown)

⚠ WARNING

Do not apply power unless a qualified Carrier technician is present. Electrical shock could cause serious personal injury or death.

11. Apply power to the control center. Go to the ICVC and access the MENU→SERVICE→VFD CONFIG DATA→VFD_CONF screen. Confirm that the parameters entered in VFD_CONF match the information on the Machine Nameplate and Sales Requisition. Confirm that the serial numbers on the chiller, Machine Nameplate, and Sales Requisition are consistent.

Ground Fault Troubleshooting — Use this procedure only if ground faults are declared:

⚠ CAUTION

Disconnect the motor leads from the control center before a motor insulation test is performed. The voltage generated from the testing equipment will damage the VFD.

Test the compressor motor and its power lead insulation resistance with a 500-v insulation tester such as a megohmmeter.

With the tester connected to the motor leads, take 10 second and 60 second megaohm readings as follows:

1. Tie terminals 1, 2, and 3 together and test between the grouped motor terminals and ground.
2. Divide the 60-second resistance reading by the 10-second reading. The ratio, or polarization index, must be one or higher. Both the 10 and 60-second readings must be at least 50 megohms.
3. If the readings are unsatisfactory, repeat the test with the motor leads disconnected from the motor. Satisfactory readings in this second test indicate the fault is in the power leads.

Carrier Comfort Network® Interface — The Carrier Comfort Network (CCN) communication bus wiring is supplied and installed by the electrical contractor. It consists of shielded, 3-conductor cable with drain wire.

The system elements are connected to the communication bus in a daisy chain arrangement. The positive pin of each system element communication connector must be wired to the positive pins of the system element on either side of it. The negative pins must be wired to the negative pins. The signal ground pins must be wired to the signal ground pins. See the 23XRV Installation Instructions.

NOTE: Conductors and drain wire must be 20 AWG (American Wire Gage) minimum stranded, tinned copper. Individual conductors must be insulated with PVC, PVC/nylon, vinyl, Teflon, or polyethylene. An aluminum/polyester 100% foil shield and an outer jacket of PVC, PVC/nylon, chrome vinyl, or Teflon with a minimum operating temperature range of -4 F to 140 F (-20 C to 60 C) is required. See table below for cables that meet the requirements.

MANUFACTURER	CABLE NO.
ALPHA	2413 or 5463
AMERICAN	A22503
BELDEN	8772
COLUMBIA	02525

When connecting the CCN communication bus to a system element, a color code system for the entire network is recommended to simplify installation and checkout. The following color code is recommended:

SIGNAL TYPE	CCN BUS CONDUCTOR INSULATION COLOR	ICVC PLUG J1 PIN NO.
+	Red	1
GROUND	White or Clear	2
-	Black	3

Power Up the Controls and Check the Oil Heater — Ensure that an oil level is visible in the oil sump before energizing the controls. A separate 15A control power circuit breaker in the control center energizes the oil heater and the control circuit. When first powered, the ICVC should display the default screen within a short period of time.

The oil heater is energized when power is applied to the control circuit. This should be done several hours before start-up to minimize oil-refrigerant migration. The oil heater is controlled by the PIC III controls and is powered through a contactor on the power panel. This arrangement allows the heater to energize when the main motor circuit breaker is off for service work or extended shutdowns. The oil heater relay status (*OIL HEATER RELAY*) can be viewed on the COMPRESS table on the ICVC. Oil sump temperature can be viewed on the ICVC default screen.

SOFTWARE VERSION — The software part number is labeled on the backside of the ICVC module. The software

version also appears on the ICVC CONFIGURATION screen as the last two digits of the software part number.

Software Configuration

WARNING

Do not operate the chiller before the control configurations have been checked in the ICVC and a Control Test has been satisfactorily completed. Protection by safety controls cannot be assumed until all control configurations have been confirmed.

As the 23XRV unit is configured, all configuration settings should be written down. A log, such as the one shown on pages CL-1 to CL-10, provides a convenient list for configuration values.

It is recommended that all control configuration tables be uploaded via Service Tool and stored for reference when the software configuration is complete.

Input the Design Set Points — Access the ICVC SET POINT screen and view/modify the BASE DEMAND LIMIT set point, and either the LCL SET POINT or the ECL SET POINT. The PIC III module can control a set point to either the leaving or entering chilled liquid. This control method is set in the EQUIPMENT SERVICE (TEMP_CTL) table. The default setting of ECL CONTROL OPTION is DSABLE so the PIC III module will control the leaving chilled liquid temperature.

Input the Local Occupancy Schedule (OCCPC01S) — Access the schedule OCCPC01S screen on the ICVC and set up the occupied time schedule according to the customer's requirements. If no schedule is available, the default is factory set for 24 hours occupied, 7 days per week including holidays.

For more information about how to set up a time schedule, see the Time Schedule Operation section, page 28.

The CCN Occupied Schedule (OCCPC03S) should be configured if a CCN system is being installed or if a secondary time schedule is needed.

NOTE: The default CCN Occupied Schedule OCCPC03S is configured to be unoccupied.

Input Service Configurations — The following configurations require the ICVC screen to be in the SERVICE portion of the menu.

- CONTROL TEST
- EQUIPMENT CONFIGURATION
- VFD CONFIG DATA
- EQUIPMENT SERVICE
- TIME AND DATE
- ICVC CONFIGURATION (PASSWORD)

PASSWORD — When accessing the SERVICE tables, a password must be entered. All ICVC are initially set for a password of 1-1-1-1.

INPUT TIME AND DATE — Access the TIME AND DATE table on the SERVICE menu. Input the present time of day, date, and day of the week. The *HOLIDAY* parameter should only be configured to YES if the present day is a holiday.

NOTE: Because a schedule is integral to the chiller control sequence, the chiller will not start until the time and date have been set.

CHANGE ICVC CONFIGURATION IF NECESSARY — From the SERVICE table, access the ICVC CONFIGURATION screen. From there, view or modify the ICVC CCN address, change to US Imperial (English) or Metric (SI) units, LID Language, and change the password. If there is more than

one chiller at the jobsite, change the ICVC CCN address on each chiller so that each chiller has its own address. Note and record the new address. Change the screen to Metric (SI) units as required, and change the ICVC password if desired.

TO CHANGE THE PASSWORD — The password may be changed from the ICVC CONFIGURATION screen.

1. Press the **MENU** and **SERVICE** softkeys. Enter the current password and highlight ICVC CONFIGURATION. Press the **SELECT** softkey. Only the last 6 entries on the ICVC CONFIG screen can be changed: *BUS #, ADDRESS #, BAUD RATE, US IMP/METRIC, PASSWORD, and LID LANGUAGE.*
2. Use the **ENTER** softkey to scroll to *PASSWORD*. The first digit of the password is highlighted on the screen.
3. To change the digit, press the **INCREASE** or **DECREASE** softkey. When the desired digit is seen, press the **ENTER** softkey.
4. The next digit is highlighted. Change it, and the third and fourth digits in the same way the first was changed.
5. After the last password digit is changed, the ICVC goes to the *LID LANGUAGE* parameter. Press the **EXIT** softkey to leave that screen and return to the SERVICE menu.

IMPORTANT: Be sure to remember the password. Retain a copy for future reference. Without the password, access to the SERVICE menu will not be possible unless the ICVC_PWD menu on the STATUS screen is accessed by a Carrier representative

TO CHANGE THE ICVC DISPLAY FROM ENGLISH TO METRIC UNITS — By default, the ICVC displays information in English units. To change to metric units, access the ICVC CONFIGURATION screen:

1. Press the **MENU** and **SERVICE** softkeys. Enter the password and highlight ICVC CONFIGURATION. Press the **SELECT** softkey.
2. Use the **ENTER** softkey to scroll to *US imp* or *METRIC*.
3. Press the softkey that corresponds to the units desired for display on the ICVC (e.g., *US imp* or *METRIC*).

MODIFY CONTROLLER IDENTIFICATION IF NECESSARY — The ICVC module address can be changed from the ICVC CONFIGURATION screen. Change this address for each chiller if there is more than one chiller at the jobsite. Write the new address on the ICVC module for future reference.

INPUT EQUIPMENT SERVICE PARAMETERS IF NECESSARY — The EQUIPMENT SERVICE table has seven service tables:

1. OPTIONS
2. SETUP1
3. SETUP2
4. SETUP3
5. SETUP4 (P Compressor)
6. SETUP5 (P Compressor)
7. LEADLAG
8. RAMP_DEM
9. TEMP_CTL

Check VFD_CONFIG TABLE — Enter the VFD_CONF screen on the ICVC by entering the following screen sequence:

- MENU
- SERVICE
- Password (default 1111)
- VFD CONFIG DATA
- Password (default 4444)
- VFD_CONF

Confirm that the following parameters in the VFD_CONF screen match the values on the Machine Electrical Data Nameplate (see Fig. 48):

- Motor Nameplate Voltage — Voltage required to run at motor rating.
- Compressor 100% Speed — Compressor speed required to run at chiller design point.
- Rated Line Voltage — Nominal line voltage selected for the job site.
- Rated Line Amps — Line current required for the chiller to run at the design point.
- Rated Line Kilowatts — Line power required for the chiller to run at the design point.
- Motor Rated Load kW — Power consumed by the motor when running at the chiller design point.
- Motor Rated Load Amps — Motor current required for the chiller to run at the design point.
- Motor Nameplate Amps — Motor nameplate full load amps.
- Motor Nameplate RPM — Rated speed of the motor when running at motor nameplate rated frequency, rated current, and rated voltage.
- Motor Nameplate kW — Motor nameplate rated power.
- Inverter PWM Frequency — Sets the carrier frequency for the pulse width modulation output.

NOTE: Other parameters on these screens are normally left at the default settings; however, they may be changed by the operator as required. The voltage and current imbalance level and imbalance persistence time on the VFD_CONF table can be adjusted to increase or decrease the sensitivity of these fault conditions. Increasing time or persistence decreases sensitivity. Decreasing time or persistence increases sensitivity to the fault condition.

Modify Minimum and Maximum Load Points (HGBP DELTA T1/HGBP DELTA P1, HGBP DELTA T2/HGBP DELTA P2) If Necessary — The default settings of the stall prevention parameters in the OPTIONS screen are set so the optional HGBP will not be energized during normal operating conditions. In addition to stall prevention, hot gas bypass may be useful for preventing excessive recycle restarts and maintaining temperature control in response to rapid load changes at low compressor speed. The chiller needs only to close the optional hot gas bypass valve to increase capacity when the chiller is running at low load with hot gas bypass active. It takes a few minutes for the chiller to start if it has shut down in recycle restart mode.

When HGBP option is set to 1, hot gas bypass operation can be adjusted for minimum chiller load and lift control. The *HGBP DELTA T1/HGBP DELTA P1, HGBP DELTA T2/HGBP DELTA P2* parameters in the OPTIONS screen determine when the optional hot gas bypass valve will open and close. These points should be set based on individual chiller operating conditions.

An example of such a configuration is shown below.

Refrigerant: HFC-134a

Estimated Minimum Load Conditions:

- 44 F (6.7 C) LCL
- 45.5 F (7.5 C) ECL
- 43 F (6.1 C) Suction Temperature

70 F (21.1 C) Condensing Temperature

Estimated Maximum Load Conditions:

- 44 F (6.7 C) LCL
- 54 F (12.2 C) ECL
- 42 F (5.6 C) Suction Temperature
- 98 F (36.7 C) Condensing Temperature

Calculate Maximum Load — To calculate the minimum load points, use data from the sales requisition or estimate the chilled liquid delta T based on a percentage of full load where the HGBP should be energized. The minimum condensing pressure can be based on the entering condenser liquid temperature available at minimum load. Use the proper saturated pressure and temperature for R-134a.

Suction Temperature:

$$43 \text{ F (6.1 C)} = 38 \text{ psig (262 kPa) saturated refrigerant pressure (R-134a)}$$

Condensing Temperature:

$$70 \text{ F (21.1 C)} = 71 \text{ psig (490 kPa) saturated refrigerant pressure (R-134a)}$$

Minimum Load *HGBP DELTA T1* (at 15% load):

$$0.15 \times (54-44) = 1.5^\circ \text{ F (} 0.15 \times (12.2 - 6.7) = 0.8^\circ \text{ C)}$$

Minimum Load HGBP DELTA P1:

$$71 - 38 = 33 \text{ psid (} 490 - 262 = 228 \text{ kPa)}$$

Determine *HGBP DELTA T2/HGBP DELTA P1*:

Set *HGBP DELTA T2* equal to 0.1° F larger than *HGBP DELTA T1*:

$$HGBP \text{ DELTA } T2 = HGBP \text{ DELTA } T1 + 0.1 = 1.6^\circ \text{ F (} 0.8 + 0.06 = 0.9^\circ \text{ C)}$$

Set *HGBP DELTA P2* to a large value to create a steep slope (see Fig. 22 and 23) *HGBP DELTA P2* = 200 psid (1379 kPa).

If the hot gas bypass is energized too soon or too late:

HGBP ENERGIZED TOO SOON	HGBP ENERGIZED TOO LATE
Decrease HGBP DELTA T1 and HGBP DELTA T2 by 0.5° F (0.3° C)	Increase HGBP DELTA T1 and HGBP DELTA T2 by 0.5° F (0.3° C)

If variable evaporator flow is applied, changes to *DELTA T1* proportional to the reduction in evaporator liquid flow rate are required.

The differential pressure (ΔP) and temperature (ΔT) can be monitored during chiller operation by viewing *ACTIVE DELTA P* and *ACTIVE DELTA T* (HEAT_EX screen). Comparing *HGBP DELTA T* to *ACTIVE DELTA T* will determine when the HGBP valve will open. The smaller the difference between the *HGBP DELTA T* and the *ACTIVE DELTA T* values, the closer to stall prevention or the point at which the HGBP will open.

If the *ACTIVE DELTA T* is less than the *HGBP DELTA T*, the HGBP valve will be activated. The HGBP will be deactivated once the *ACTIVE DELTA T* is greater than the *HGBP DELTA T plus the HGBP DEADBAND* if the *ACTIVE DELTA P* is less than *HGBP DELTA P1*.

When the HGBP option is set to 2, *HGBP ON DELTA SPEED* should be based on the estimated minimum load conditions as was *HGBP DELTA T1* in the example above. *HGBP OFF DELTA SPEED* functions similar to a deadband above the temperature entered in *HGBP ON DELTA T* as shown in Fig. 33.

MODIFY EQUIPMENT CONFIGURATION IF NECESSARY — The EQUIPMENT SERVICE table has screens to select, view, or modify parameters. Carrier's certified drawings have the configuration values required for the jobsite. Modify these values only if requested.

SERVICE Screen Modifications — Change the values on these screens according to specific job data. See the certified drawings for the correct values. Modifications can include:

- Chilled liquid reset
- Entering chilled liquid control (Enable/Disable)
- 4 to 20 mA demand limit
- Auto restart option (Enable/Disable)
- Remote contact option (Enable/Disable)

Owner-Modified CCN Tables — The following EQUIPMENT CONFIGURATION screens are described for reference only.

OCCDEFCS — The OCCDEFCS screen contains the Local and CCN time schedules, which can be modified here or on the SCHEDULE screen as described previously.

HOLIDAYS — From the HOLIDAYS screen, the days of the year that holidays are in effect can be configured. See the holiday paragraphs in the Controls section for more details.

BRODEF — The BRODEF screen defines the start and end of daylight savings time. By default this feature is enabled. Enter the dates for the start and end of daylight savings if required for your location. Note that for *DAY OF WEEK*, 1 represents Monday. *START WEEK* and *STOP WEEK* refer to the instance of the selected *DAY OF WEEK* during the selected *START MONTH* and year. To disable the feature, change *START ADVANCE* and *STOP BACK* times to 0 (minutes). In the BRODEF table the user may also identify a chiller as the time broadcaster for a CCN network with *TIME BROADCAST ENABLE*. There should be only one device on a CCN network which is designated as the time broadcaster.

ALARM ROUTING (Fig. 49) — *ALARM ROUTING* is in the table SERVICE/EQUIPMENT CONFIGURATION/NET_OPT under the heading Alarm Configuration. ALARM ROUTING consists of an 8-bit binary number. Only bits 1, 2, and 4 (counting from the left) are used. The bits can be set by any device which can access and change configuration tables. If any of these 3 bits is set to 1, the ICVC will broadcast any alarms which occur.

Bit 1: Indicates that the alarm should be read and processed by a front end device, such as a ComfortWORKS® device.

Bit 2: Indicates that the alarm should be read and processed by a TeLINK or Autodial Gateway module.

ALARM CONTROL ALARM ROUTING

Alarm routing settings should be left at default settings and only be changed by technicians trained in CCN. These settings determine which CCN system elements will receive and process alarms sent by the ICVC. Input for the decision consists of eight digits, each of which can be set to either 0 or 1. Setting a digit to 1 specifies that alarms will be sent to the system element that corresponds to that digit. Setting all digits to 0 disables alarm processing. Digits in this decision correspond to CCN system elements in the following manner:

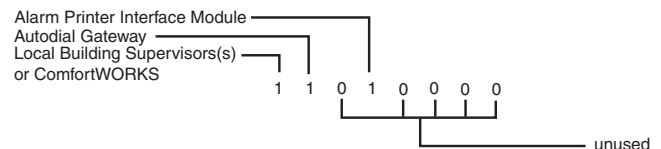

NOTE: If your CCN does not contain ComfortWORKS® controls or a Building Supervisor or Autodial Gateway to serve as an alarm acknowledger, set all digits in this decision to 0 in order to prevent unnecessary activity on the CCN Communication Bus.

Allowable Entries 00000000 to 11111111
0 = Disabled, 1 = Enabled
Default Value 10000000

Fig. 49 — Alarm Control and Alarm Routing

Bit 4: Indicates that the alarm should be read and processed by an alarm printer interface (an optional module), ServiceLink, or a DataLINK™ device.

The RE-ALARM TIME is a time period after which, if a preexisting and previously broadcast alarm has not been cleared, it will be rebroadcast on the CCN network.

Other Tables — The CONSUME, NET OPT, and RUN-TIME screens contain parameters used with a CCN system. See the applicable CCN manual for more information on these screens. These tables can only be defined from a CCN Building Supervisor.

Perform a Control Test — Check the safety controls status by performing an automated control test. Access the CONTROL TEST table and select a test to be performed function (see Tables 14 and 15).

The Automated Control Test checks all outputs and inputs for function. The compressor must be in the OFF mode to operate the controls test. The compressor can be put in OFF mode by pressing the STOP push-button on the ICVC. Each test asks the operator to confirm the operation is occurring and whether or not to continue. If an error occurs, the operator can try to address the problem as the test is being done or note the problem and proceed to the next test.

When the control test is finished or the **[EXIT]** softkey is pressed, the test stops, and the CONTROL TEST menu displays. If a specific automated test procedure is not completed, access the particular control test to test the function when ready. The CONTROL TEST menu is described in Table 15.

The *EVAPORATOR PRESSURE*, *CONDENSER PRESSURE*, *DISCHARGE PRESSURE*, and *OIL PRESSURE DELTA P* pressure transducers should be calibrated prior to start-up. If pressure transducers are installed on the waterbox nozzles, *CHILLED LIQUID DELTA P* and *CONDENSER LIQUID DELTA P* transducers should also be calibrated.

Table 14 — Control Tests

CONTROL	TEST
CCM Thermistors, PD4 EXV Thermistor*	Check of all thermistors.
CCM Pressure Transducers	Check of all transducers.
Pumps	Checks operation of pump outputs; pumps are activated. Also tests associated inputs such as flow or pressure.
Discrete Outputs	Activation of all on/off outputs individually.
Oil Reclaim Output	Checks CCM 4-20mA oil reclaim output with power removed from oil reclaim actuator.
Head Pressure Output	Manually varies the head pressure output from low voltage field wiring terminal strip.
Pumpdown/ Lockout	Pumpdown prevents the low refrigerant alarm during evacuation so refrigerant can be removed from the unit. Also locks the compressor off and starts the liquid pumps.
Terminate Lockout	To charge refrigerant and enable the chiller to run after pumpdown lockout.
Condenser Level EXV Output (P Compressor Only)	Manually varies the EXV output. After test the EXV will be driven to the fully closed position.
Economizer EXV Output (P Compressor Only)	Manually varies the economizer EXV output. After test the economizer EXV will be driven to the fully closed position.

*P compressors with economizer option only.

NOTE: During any of the tests, an out-of-range reading will have an asterisk (*) next to the reading and a message will be displayed.

Table 15 — Control Test Menu Functions

TESTS TO BE PERFORMED	DEVICES TESTED
1. Thermistors	Entering Chilled Liquid Leaving Chilled Liquid Entering Cond Liquid Leaving Cond Liquid Evap Refrig Liquid Temp Comp Discharge Temp Oil Sump Temp Vaporizer Temp Comp Motor Winding Temp Spare Temperature 1 Spare Temperature 2 Remote Reset Sensor Economizer Superheat Sensor (P compressor only)
2. Pressure Transducers	Evaporator Pressure Condenser Pressure Discharge Pressure Oil Pressure Delta P Chilled Liquid Delta P Condenser Liquid Delta P Transducer Voltage Ref Humidity Sensor Input Relative Humidity Economizer Pressure (P compressor only)
3. Pumps	Operates Pump, Displays Delta P and confirms flow for oil pump, chilled liquid pump and condenser liquid pump.
4. Discrete Outputs	Oil Heater Relay Secondary Oil Heater Relay (P Compressor Only) Vaporizer Heater Hot Gas Bypass Relay Tower Fan Relay Low Tower Fan Relay High Alarm Relay VFD Coolant Solenoid Shunt Trip Relay
5. Oil Reclaim Output	Percentage and mA (% and mA)
6. Head Pressure Output	Head Pressure Reference (4 to 20mA) (The output is 2 mA when the chiller is not running.)
7. Pumpdown Lockout	When using pumpdown/lockout, observe freeze up precautions when removing charge: Instructs operator which valves to close and when. Starts chilled liquid and condenser liquid pumps and requests flow confirmation. Monitors: Evaporator pressure Condenser pressure Evaporator temperature during pumpout procedures Turns pumps off after pumpdown. Locks out compressor.
8. Terminate Lockout	Starts pumps and monitors flows. Instructs operator which valves to open and when. Monitors: Evaporator pressure Condenser pressure Evaporator temperature during charging process Terminates compressor lockout.

Pressure Transducer and Optional Flow Device Calibration — Transducers measuring single pressure values (such as *CONDENSER PRESSURE* and *EVAPORATOR PRESSURE*) are calibrated individually, while a pair of transducers measuring a pressure differential (*OIL PRESSURE DELTA P*, *CHILLED LIQUID DELTA P*, or *CONDENSER LIQUID DELTA P*) are calibrated together as a differential. Transducers for sensing liquid side flow are not provided as standard. Oil pressure, refrigerant pressure and liquid delta P readings can be viewed and calibrated from the COMPRESS and HEAT_EX screens on the ICVC controller. Each transducer or transducer pair can be calibrated at two points: “zero” (0 psig or 0 kPa) and “high end” (between 25 and 250 psig, or between 173 and 1724 kPa). It is good practice to calibrate at initial start-up. Calibration is particularly important at high altitudes to ensure the proper refrigerant temperature-pressure relationship.

ZERO POINT CALIBRATION — Shut down the compressor, and cooler and condenser pumps. There must be no water flow through the heat exchangers, but these systems must be filled. For differential pairs, leave the transducers installed. For

single value transducers, disconnect the transducer's electrical cable, remove the sensor from its Schrader fitting, then reconnect the cable.

NOTE: If the cooler or condenser vessels are at 0 psig (0 kPa) or are open to atmospheric pressure, the transducers can be calibrated for the zero point without removal.

Access the HEAT_EX or COMPRESS screen under the STATUS menu, and view the particular transducer reading (OIL PRESSURE DELTA P is in the COMPRESS screen; all others are in the HEAT_EX screen). If the displayed reading is not 0 psi (0 kPa), press the SELECT key to highlight the associated line in the display, then the ENTER key. (For zero point calibration, the INCREASE and DECREASE keys have no effect.) The value should change to 0.0.

If the ICVC fails to accept the zero point calibration, the value will not change to 0.0 and the display will show "Higher Force In Effect". This indicates that the sensor voltage is out of the acceptable range. For each single value transducer there are 3 terminals at the CCM: 0 vdc (low) connected to the black wire, "sensor" voltage connected to the white or clear wire, and 5.00 vdc (high) connected to the red wire. With a base supply voltage of 5.00 volts, the acceptable range of voltage taken between the low (black wire) and sensor terminals (white or clear wire) for zero point calibration is 0.40 to 0.55 v. For each transducer differential pair there are two 3-terminal sets at the CCM. With a base supply voltage of 5.00 volts, the acceptable range of voltage taken between the sensor terminal (white or clear wire) for the higher pressure transducer (liquid inlet or oil pump discharge) and the sensor terminal (white or clear wire) for the lower pressure transducer (liquid outlet or oil sump) for zero point calibration is -0.065 to +0.085 v. If this occurs with a differential pair, one possible remedy is to swap the high end (e.g., inlet) and low end (e.g., outlet) transducers. In most cases this puts the voltage difference of the sensor pair within the acceptable range.

HIGH END CALIBRATION — High end calibration can be performed between 25 and 250 psig (173 and 1724 kPa), comparing the pressure readings in the ICVC display to an accurate refrigeration gage. High end calibration may improve transducer accuracy over the full pressure range. High end calibration is not recommended for transducer differential pairs. Pressure can be provided by attaching a regulated 250 psig (1724 kPa) pressure source, such as from a nitrogen cylinder, to the transducer. It is good practice to perform the high end calibration near a pressure that the sensor will typically be exposed to.

Access the HEAT_EX screen under the STATUS menu, and the CONDENSER PRESSURE or EVAPORATOR PRESSURE to the reference pressure gage. To change the displayed reading, press the SELECT key to highlight the associated line in the display, then the INCREASE or DECREASE key to set the new value, then the ENTER key. Generally, the value can be changed to any value within $\pm 15\%$ of a nominal value.

NOTE: Prior calibrations may have shifted the present pre-calibration value from the center of this range. In this case, the limit of acceptable new values will be less than 15% in one direction.

If the ICVC fails to accept the high end calibration, the value will not change and the display will show "Higher Force In Effect." This indicates that the sensor voltage is out of the acceptable range for the entered value. In this case, the pressure transducer may need to be replaced.

Each pressure transducer is supplied with 5 vdc power from the CCM through the red wire. Pressure transducer readings are derived from voltage ratio, not absolute voltage, which compensates for any reference voltage variation. If this power supply fails, a transducer voltage reference alarm (239) is generated. If transducer readings are suspected of being faulty, check the supply voltage, measured between the high and low (red wire and black wire) terminals of any transducer 3

terminal connection at the CCM. This is also displayed in CONTROL TEST under PRESSURE TRANSDUCERS.

Check Optional Pumpout System Controls and Compressor

— Controls include an on/off switch, a 0.5-amp fuse for the secondary side of the transformer, 0.25-amp fuses for the primary side of the transformer, the compressor overloads, an internal thermostat, a compressor contactor, refrigerant low pressure cutout and a refrigerant high pressure cutout. The high pressure cutout is factory set to open at 185 psig (1276 kPa) and reset at 140 psig (965 kPa).

The low pressure cutout is factory set to open at 7 psia (-15.7 in. Hg) and close at 9 psia (-11.6 in. Hg). Ensure the water-cooled condenser has been connected. Ensure oil is visible in the compressor sight glass. Add oil if necessary.

See the Pumpout and Refrigerant Transfer Procedures section on page 86 and the Optional Pumpout System Maintenance section on page 99 for details on the transfer of refrigerant, oil specifications, etc.

High Altitude Locations — Because the chiller is initially calibrated at sea level, it is necessary to recalibrate the pressure transducers if the chiller has been moved to a high altitude location. See the calibration procedure in the Troubleshooting Guide section.

Charge Refrigerant into Chiller

⚠ CAUTION

The transfer, addition, or removal of refrigerant in spring isolated chillers may place severe stress on external piping if springs have not been blocked in both up and down directions. Failure to block springs in both up and down directions could result in severe personal injury and equipment damage.

⚠ CAUTION

Always operate the condenser and chilled liquid pumps during charging operations to prevent freeze-ups. Damage may result to equipment if the condenser and chilled water pumps are not operated during pumpdown or charging.

The standard 23XRV chiller is shipped with the refrigerant already charged in the vessels. However, the 23XRV chiller may be ordered with a nitrogen holding charge of 15 psig (103 kPa). In this case, evacuate the nitrogen from the entire chiller, and charge the chiller from refrigerant cylinders.

Chillers shipped with a factory charge should arrive with all isolation valves in the open position. Figures 2-4 and 10-13 show the location of the isolation valves listed in the Initial Start-Up Checklist.

CHILLER EQUALIZATION WITHOUT A PUMPOUT UNIT

⚠ WARNING

When equalizing refrigerant pressure on the 23XRV chiller after service work or during the initial chiller start-up, *do not use the discharge isolation valve to equalize* because the force that could be exerted by the valve handle could cause personal injury. Either the motor cooling isolation valve or the charging hose (connected between the pumpout valves on top of the cooler and condenser) should be used as the equalization valve.

To equalize the pressure differential on a refrigerant isolated 23XRV chiller, use the TERMINATE LOCKOUT function of

the CONTROL TEST on the SERVICE menu. This helps to turn on pumps and advises the operator on proper procedures.

The following steps describe how to equalize refrigerant pressure in an isolated 23XRV chiller without a pumpout unit.

1. Access TERMINATE LOCKOUT function on the CONTROL TEST screen.

2. **IMPORTANT:** Turn on the chilled liquid and condenser liquid pumps to prevent freezing.

3. Equalizing:

- a. Preferred method: Connect a charging hose between the two valves on top of the cooler and condenser. Open one valve fully and open the other valve slowly. This process should take approximately 15 minutes.
- b. Alternate method: Use this method if no charging hose available. Slowly open the motor cooling isolation valve. The chiller cooler and condenser pressures will gradually equalize. This process takes approximately 15 minutes.

Note that for option (b), since the condenser contains liquid refrigerant, the valve opening must be limited to prevent liquid refrigerant from entering the cooler which could cause potential freeze-up.

4. Once the pressures have equalized, the following isolation valves should be opened:
 - discharge isolation valve
 - cooler inlet valve
 - HGBP isolation valve (optional)
 - vaporizer condenser gas valve
 - filter/drier isolation valve (2 places)
 - VFD cooling isolation valves (2 places)
 - oil filter isolation valve
 - oil pump isolation valve
 - oil pressure regulator valve

Refer to Fig. 2-4 and 10-13 for isolation valve locations.

⚠ CAUTION

Whenever turning the discharge isolation valve, be sure that the spring-loaded lever lock fully engages within one of the latch plate detents. This will prevent the valve from opening or closing during service work or during chiller operation.

CHILLER EQUALIZATION WITH PUMPOUT UNIT — The following steps describe how to equalize refrigerant pressure on an isolated 23XRV chiller using the pumpout unit.

NOTE: The top valve tee on a unit-mounted pumpout is connected to the condenser and the bottom valve tee is

connected to the cooler. This is different from unit-mounted installations on other Carrier chillers.

1. Access the TERMINATE LOCKOUT function on the CONTROL TEST screen.

2. **IMPORTANT:** Turn on the chilled liquid and condenser liquid pumps to prevent possible freezing.

3. Refer to Fig. 40-43. Open valve 4 on the pumpout unit and open valves 1a and 1b on the chiller cooler and condenser. Slowly open valve 2 on the pumpout unit to equalize the pressure. This process takes approximately 15 minutes.

4. Once the pressures have equalized, the following isolation valves should be opened:

- discharge isolation valve
- cooler inlet valve
- hot gas bypass valve
- vaporizer condenser gas valve
- oil pump valve
- oil filter valve
- oil pressure regulator valve
- filter/drier valve (2 places)
- VFD cooling inlet valve
- VFD cooling drain valve

Refer to Fig. 2-7 and Oil Heater section on page 95 for isolation valve locations.

⚠ WARNING

Whenever turning the discharge isolation valve, be sure that the spring-loaded lever lock fully engages within one of the latch plate detents. This will prevent the valve from opening or closing during service work or during chiller operation. Opening of the valve during service would result in the release of the refrigerant charge which could result in severe personal injury or death.

The full refrigerant charge on the 23XRV chiller will vary with chiller components and design conditions, as indicated on the job data specifications. An approximate charge may be determined by adding the condenser charge to the cooler charge as listed in Tables 16 and 17.

⚠ CAUTION

Always operate the condenser and chilled liquid pumps whenever charging, transferring, or removing refrigerant from the chiller to prevent damage to the heat exchanger tubes.

Table 16 — Refrigerant Charges, Frame Sizes 3-5

FRAME SIZE	COOLER LENGTH FT (M)	COOLER CODE	CHARGE AMOUNT (R-134a)			
			WITH ECONOMIZER		WITHOUT ECONOMIZER	
			lb (± 25 lb)	kg (± 11 kg)	lb (± 25 lb)	kg (± 11 kg)
3	12 (3.6)	30	800	363	650	295
		31	800	363	650	295
		32	800	363	650	295
	14 (4.3)	35	910	413	760	345
		36	910	413	760	345
		37	910	413	760	345
4	12 (3.6)	40	900	408	750	340
		41	900	408	750	340
		42	900	408	750	340
	14 (4.3)	45	1015	460	865	392
		46	1015	460	865	392
		47	1015	460	865	392
5	12 (3.6)	50	1250	567	1100	499
		51	1250	567	1100	499
		52	1250	567	1100	499
	14 (4.3)	55	1430	649	1280	581
		56	1430	649	1280	581
		57	1430	649	1280	581

Table 17 — Refrigerant Charges, Frame Sizes A,B

FRAME SIZE	COOLER LENGTH FT (M)	CHARGE AMOUNT (R-134a)			
		WITH ECONOMIZER		WITHOUT ECONOMIZER	
		lb (± 25 lb)	kg (± 11 kg)	lb (± 25 lb)	kg (± 11 kg)
A1	12 (3.6)	840	381	820	372
A2		860	390	840	381
A3		880	399	860	390
A4		900	408	880	399
A5		930	422	910	413
A6		960	435	940	426
B1	14 (4.3)	950	431	930	422
B2		970	440	950	431
B3		1000	454	980	445
B4		1020	463	1000	454
B5		1060	481	1040	472
B6		1090	494	1070	485

CHILLER SHIPPED WITH HOLDING CHARGE — Use the CONTROL TEST TERMINATE LOCKOUT function to monitor conditions and start the pumps.

If the chiller has been shipped with a holding charge, the refrigerant is added through the refrigerant charging valve (Fig. 40-43, valves 1a and 1b) or to the pumpout charging connection. First evacuate the nitrogen holding charge from the chiller vessels. Charge the refrigerant as a gas until the system pressure exceeds 35 psig (141 kPa) for HFC-134a. After the chiller is beyond this pressure the refrigerant should be charged as a liquid until all the recommended refrigerant charge has been added.

TRIMMING REFRIGERANT CHARGE — The 23XRV chiller is shipped with the correct charge for the design duty of the chiller. The LTD (leaving temperature difference) between the *EVAP REFRIG LIQUID TEMP* and *LEAVING CHILLED LIQUID* can be checked against the design conditions to confirm that the charge is correct. In the case where leaks have been found and corrected and the LTD is greater than about 4° F (2.2° C) above design, add refrigerant until the full load design LTD is approached. (A high cooler LTD can also be caused by dirty tubes, water box division plate bypass, a partially closed liquid isolation valve, or the float valve.)

Trimming the charge can best be accomplished when the design load is available. The calibration of the *EVAP REFRIG LIQUID TEMP* and *LEAVING CHILLED LIQUID* temperature sensors should be confirmed prior to checking for proper cooler LTD. Compare the difference between *EVAP REFRIG LIQUID TEMP* and *LEAVING CHILLED LIQUID* temperatures to the chiller design conditions. Add or remove refrigerant, if necessary, to bring the cooler leaving temperature difference to design conditions or within minimum differential.

Check for low load oil recovery after making adjustments to the refrigerant charge. The bubbling mixture of refrigerant and oil mixture should be visible through the vaporizer sight glass at low load when the oil reclaim valve is open. If a bubbling mixture is not observed when the oil reclaim valve is open, add refrigerant.

The preferred location at which refrigerant should be added directly into the chiller is through the service valves on top of the cooler condenser. If these valves are not accessible due to presence of an attached pumpdown unit which does not have a storage tank, slowly add charge through the valve connected to the side of the condenser drain float sump. Adding charge through the cooler refrigerant pumpout valve at the base of the cooler (off the liquid line) may force debris into the condenser float valve and is not recommended.

INITIAL START-UP

In order for the Reliance VFD to be eligible for the full warranty period, the following conditions must be met:

1. The chiller must be started by a technician that has completed Reliance LiquiFlo2 training.
2. The start-up technician must be registered with Reliance.
3. The start-up technician must register the chiller start-up on the Reliance web site.

Preparation — Before starting the chiller, verify:

1. Power is on to the CB2 control power circuit breaker, oil pump relay, tower fan starter, oil heater relay, and the chiller control center.
2. The CB1 main control center circuit breaker is in the On position.
3. Cooling tower liquid is at proper level and at-or-below design entering temperature. Check cooling tower bypass valve.
4. Chiller is charged with refrigerant and all refrigerant and oil valves are in their proper operating positions.
5. Oil is at the proper level in the oil sump sight glass.
6. The Oil Sump Temperature must be above 140 F (60 C) or *CALC EVAP SAT TEMP* plus 15° F (8.3° C) before the controls will allow the chiller to start to ensure that a sufficient amount of refrigerant has been driven out of the oil.
7. All valves listed on page CL-3 of the Initial Start-Up Checklist are fully open.
8. The VFD cold plate refrigerant isolation valves are open.
9. Remove the control center shipping bracket (see Fig. 50).
NOTE: For seismic units, do not remove the shipping bracket.

CAUTION

Operating the chiller with the shipping bracket attached may result in excessive vibration and noise. The shipping brace should be removed to avoid possible equipment damage (except for seismic units).

SHIPPING BRACKET
(FOR SEISMIC UNITS,
DO NOT REMOVE)

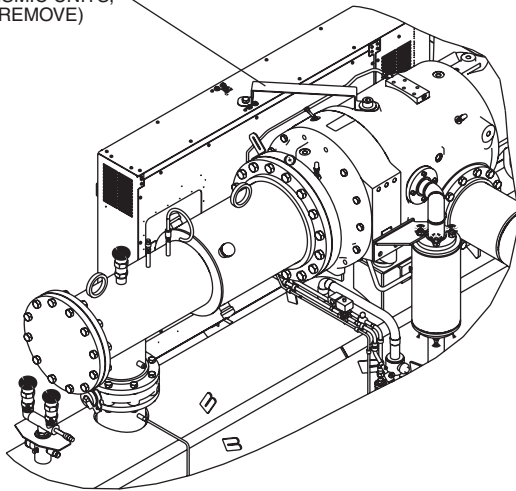

**Fig. 50 — Control Center Shipping Bracket
(Unit with R Compressor Shown)**

WARNING

Do not permit liquid or brine that is warmer than 110 F (43 C) to flow through the cooler or condenser. Refrigerant overpressure may discharge through the relief valves and result in the loss of refrigerant charge and possible personal injury.

10. Access the CONTROL TEST screen. Scroll down on the *TERMINATE LOCKOUT* option. Press the SELECT (to enable the chiller to start) and answer YES to restore unit to operating mode. The chiller is locked out at the factory in order to prevent accidental start-up.

Check Oil Pressure and Compressor Stop — Start the chiller and allow it to automatically ramp load.

1. Two minutes after start-up, note the *OIL PRESSURE DELTA P* reading on the ICVC default screen. The *OIL PRESSURE DELTA P* is the difference between the oil pressure leaving the oil filter and the oil sump pressure. The minimum *OIL PRESSURE DELTA P* is 18 psid (124 kPad) after *OIL PRESSURE VERIFY TIME* is exceeded. The *OIL PRESSURE DELTA P* is displayed on the COMPRESS, STARTUP, PRESSURE TRANSDUCERS, PUMPS, and DEFAULT screens. A normal full load reading is approximately 20 to 28 psid (138 to 193 kPad).
2. Press the STOP softkey and listen for any unusual sounds from the compressor as it coasts to a stop.

To Prevent Accidental Start-Up — The chiller is shipped with the *CHILLER START/STOP* parameter in the MAINSTAT screen set to STOP. Once installed, a chiller STOP override setting may be entered to prevent accidental start-up during service or whenever necessary. Access the MAINSTAT screen and using the [NEXT] or [PREVIOUS] softkeys, highlight the *CHILLER START/STOP* parameter. Override the current START value by pressing the [SELECT] softkey. Press the [STOP] softkey followed by the [ENTER] softkey. The word SUPVSR! displays on the ICVC indicating the STOP override is in place.

To start the chiller the STOP override setting must first be removed. Access the MAINSTAT screen and using [NEXT] or [PREVIOUS] softkeys highlight *CHILLER START/STOP*. The 3 softkeys that appear represent 3 choices:

- [START] — forces the chiller ON
- [STOP] — forces the chiller OFF
- [RELEASE] — puts the chiller under remote or schedule control.

To return the chiller to normal control, press the [RELEASE] softkey followed by the [ENTER] softkey. For more information, see Local Start-Up, page 60.

The default ICVC screen message line indicates which command is in effect.

Check Chiller Operating Condition — Check to be sure that chiller temperatures, pressures, liquid flows, and oil and refrigerant levels indicate the system is functioning properly.

Instruct the Customer Operator — Ensure the operator(s) understands all operating and maintenance procedures. Point out the various chiller parts and explain their function as part of the complete system.

COOLER-CONDENSER — Float chamber, relief valves, refrigerant charging valve, temperature sensor locations, pressure transducer locations, Schrader fittings, waterboxes and tubes, and vents and drains.

OPTIONAL PUMPOUT STORAGE TANK AND PUMPOUT SYSTEM — Transfer valves and pumpout system, refrigerant charging and pumpdown procedure, and relief devices.

COMPRESSOR ASSEMBLY — Motor cooling system, oil system, temperature and pressure sensors, sight glasses, motor temperature sensors, synthetic oil, and compressor serviceability.

COMPRESSOR LUBRICATION SYSTEM — Concentrator, oil pump, oil filter, oil heaters, oil charge and specification, strainers, sight glasses, operating and shutdown oil level, temperature and pressure sensors, and oil charging connections.

CONTROL SYSTEM — CCN and LOCAL start, reset, menu, softkey functions, ICVC operation, occupancy schedule, set points, safety controls, and auxiliary and optional controls.

AUXILIARY EQUIPMENT — Disconnects, separate electrical sources, pumps, cooling tower, chilled liquid strainers, and condenser liquid strainers.

DESCRIBE CHILLER CYCLES — Refrigerant, motor cooling, lubrication, and oil reclaim.

REVIEW MAINTENANCE — Scheduled, routine, and extended shutdowns, importance of a log sheet, importance of liquid treatment and tube cleaning, and importance of maintaining a leak-free chiller.

SAFETY DEVICES AND PROCEDURES — Electrical disconnects, relief device inspection, and handling refrigerant.

CHECK OPERATOR KNOWLEDGE — Start, stop, and shutdown procedures, safety and operating controls, refrigerant and oil charging, and job safety.

REVIEW THE START-UP, OPERATION AND MAINTENANCE MANUAL

⚠ CAUTION

Manuals and notebooks should not be stored under the VFD power module, they will block air flow into the power module cooling fan and cause the VFD to overheat.

OPERATING INSTRUCTIONS

Operator Duties

1. Become familiar with the chiller and related equipment before operating the chiller.
2. Prepare the system for start-up, start and stop the chiller, and place the system in a shutdown condition.
3. Maintain a log of operating conditions and document any abnormal readings.
4. Inspect the equipment, make routine adjustments, and perform a Control Test. Maintain the proper oil and refrigerant levels.
5. Protect the system from damage during shutdown periods.
6. Maintain the set point, time schedules, and other PIC III functions.

Prepare the Chiller for Start-Up — Follow the steps described in the Initial Start-Up section, page 82.

To Start the Chiller

1. Start the liquid pumps, if they are not automatic.

2. On the ICVC default screen, press the **LOCAL** or **CCN** softkey to start the system. If the chiller is in the OCCUPIED mode and the start timers have expired, the start sequence will start. Follow the procedure described in the Start-Up/Shutdown/Recycle Sequence section, page 60.

Check the Running System — After the compressor starts, the operator should monitor the ICVC display and observe the parameters for normal operating conditions:

1. The oil sump temperature will vary from 50 F to 140 F (10 C to 60 C) depending on the operating conditions. If the chiller has not been running for a few hours the *OIL SUMP TEMP* will be warmer than the *CALC EVAP SAT TEMP*. When the chiller is not running, the oil heater is energized whenever the *OIL SUMP TEMP* is less than the smaller of 140 F (60 C) or 53 F (29.4 C) greater than the *CALC EVAP SAT TEMP*. The *OIL SUMP TEMP* generally decreases slowly following start-up and eventually stabilizes at a point lower than the temperature maintained during shutdown. The *OIL PRESS DELTA P* increases above 18 psid (124 kPad) during start-up and generally does not vary by more than ± 2 psid (14 kPad). The level in the oil sump is generally very stable. Changes in the oil level occur very slowly.
2. When the compressor is running, the liquid level should be visible in the oil sump or the strainer housing sight glass. Low oil pressure alarms are imminent if the oil level drops below the bottom of the oil strainer housing sight glass.
3. The *OIL PRESSURE DELTA P* displayed on the ICVC default screen is equal to the difference between the oil pressure leaving the oil filter and the oil sump pressure transducer readings. Typically the reading will be between 20 and 28 psid (138 and 193 kPad) after the oil pressure ramp up is complete.
4. The moisture indicator (dry-eye) sight glass on the refrigerant motor cooling line should indicate refrigerant flow and a dry condition.
5. The condenser pressure and temperature varies with the chiller design conditions. Typically the pressure will range between 60 and 135 psig (329 and 780 kPa) with a corresponding temperature range of 60 to 105 F (15 to 41 C). The condenser entering liquid temperature may be controlled below the specified design entering liquid temperature to save on compressor kilowatt requirements but, not be below 55 F (12.8 C).
6. Cooler pressure and temperature also will vary with the design conditions. Typical pressure range will be between 30 and 40 psig (204 and 260 kPa) with temperature ranging between 34 and 45 F (1 and 8 C).
7. The compressor may operate at full capacity for a short time after the pulldown ramping has ended, even though the building load is small. The active electrical demand setting can be overridden to limit the compressor kW, or the pulldown rate can be decreased to avoid a high demand charge for the short period of high demand operation. Pulldown rate can be based on load rate or temperature rate by *PULLDOWN RAMP TYPE* in the *RAMP_DEM* screen. *AMPS OR KW RAMP%/MIN* is accessed on the Equipment SERVICE screen, *RAMP_DEM* table (Table 3, Example 28). *TEMP PULLDOWN RAMP%/MIN* is accessed on the *TEMP_CTL* screen.

To Stop the Chiller

1. The occupancy schedule starts and stops the chiller automatically once the time schedule is configured.

2. The STOP button must be pressed for one second before the alarm light blinks once to confirm the button has been pressed. The compressor will then follow the normal shutdown sequence as described in the Controls section. The chiller will not restart until the **CCN** or **LOCAL** softkey is pressed. The chiller is now in the OFF control mode.

FAILURE TO STOP — If the alarm light does not blink after pressing and holding the stop button for at least one second and the chiller fails to stop, the operator should open the main circuit breaker on the front of the control panel.

IMPORTANT: Do not attempt to stop the chiller by opening an isolating knife switch. High intensity arcing may occur.

Do not restart the chiller until the problem is diagnosed and corrected.

After Limited Shutdown — No special preparations should be necessary. Follow the regular preliminary checks and starting procedures.

Preparation for Extended Shutdown — The refrigerant should be transferred into the pumpout storage tank (if supplied; see Pumpout and Refrigerant Transfer Procedures) to reduce chiller pressure and the possibility of leaks. Maintain a holding charge of 5 to 10 psi (34 to 69 kPa) of refrigerant or nitrogen to prevent air from leaking into the chiller.

If freezing temperatures are likely to occur in the chiller area, drain the chilled liquid, condenser liquid, and the pumpout condenser liquid circuits to avoid freeze-up. Keep the waterbox drains open.

Leave the oil charge in the chiller with the oil heater and controls energized to maintain the minimum oil reservoir temperature.

After Extended Shutdown — Ensure the liquid system drains are closed. It may be advisable to flush the liquid circuits to remove any soft rust which may have formed. This is a good time to brush the tubes and inspect the Schrader fittings on the optional liquid side flow devices for fouling, if necessary.

Check the cooler pressure on the ICVC default screen and compare it to the original holding charge that was left in the chiller. If (after adjusting for ambient temperature changes) any loss in pressure is indicated, check for refrigerant leaks. See Check Chiller Tightness section, page 64.

Recharge the chiller by transferring refrigerant from the pumpout storage tank (if supplied). Follow the Pumpout and Refrigerant Transfer Procedures section, page 86. Observe freeze-up precautions.

Carefully make all regular preliminary and running system checks. Perform a Control Test before start-up. If the oil level appears abnormally high, the oil may have absorbed refrigerant. A LOW OIL TEMPERATURE prestart alert will be declared if the oil temperature is not greater than the *CALC EVAP SAT TEMP* plus 15 F (8.3 C) or 140 F (60 C), whichever is lower.

Cold Weather Operation — When the entering condenser liquid drops very low (55 F [13 C] minimum), the operator or tower control should automatically cycle the cooling tower fans off to keep the temperature up. Piping may also be arranged to bypass the cooling tower. The PIC III controls have a Tower Fan Low control contact that can be used to assist in this control (see the Physical Data section on page 129 for wiring schematics).

Refrigeration Log — A refrigeration log, such as the one shown in Fig. 5I, provides a convenient checklist for routine inspection and maintenance, and provides a continuous record of chiller performance. It is an aid in scheduling routine maintenance and in diagnosing chiller problems.

Keep a record of the chiller pressures, temperatures, and liquid levels on a sheet similar to that shown. Automatic recording of PIC III data is possible through the use of CCN devices such as the Data Collection module and a Building Supervisor. Contact your Carrier representative for more information.

PUMPOUT AND REFRIGERANT TRANSFER PROCEDURES

Preparation — The 23XRV chiller may come equipped with an optional pumpout storage tank, pumpout system, or pumpout compressor. The refrigerant can be pumped for service work to either the chiller compressor evaporator vessel or chiller condenser vessel by using the optional pumpout system. If a pumpout storage tank is supplied, the refrigerant can be isolated in the storage tank. The following procedures describe how to transfer refrigerant from vessel to vessel and perform chiller evacuations.

CAUTION

Always run the chiller cooler and condenser liquid pumps and always charge or transfer refrigerant as a gas when the chiller pressure is less than 35 psig (241 kPa). Below these pressures, liquid refrigerant flashes into gas, resulting in extremely low temperatures in the cooler/condenser tubes and possibly causing tube freeze-up.

WARNING

During transfer of refrigerant into and out of the optional storage tank, carefully monitor the storage tank level gage. Do not fill the tank more than 90% of capacity to allow for refrigerant expansion. Overfilling may result in damage to the tank or personal injury.

CAUTION

Do not mix refrigerants from chillers that use different compressor oils. Compressor damage can result.

(backseated) during operation. Rotate the valve stem fully counterclockwise to open. Frontseating the valve closes the refrigerant line and opens the gage port to compressor pressure.

2. Ensure that the compressor holddown bolts have been loosened to allow free spring travel.
3. Open the refrigerant inlet valve on the pumpout compressor.
4. Oil should be visible in the pumpout unit compressor sight glass under all operating conditions and during shutdown. If oil is low, add oil as described under Optional Pumpout System Maintenance section, page 99. The pumpout unit control wiring schematic is detailed in Fig. 52.

TO READ REFRIGERANT PRESSURES DURING PUMPOUT OR LEAK TESTING:

1. The ICVC display on the chiller control center is suitable for determining refrigerant-side pressures and low (soft) vacuum. To assure the desired range and accuracy when measuring evacuation and dehydration, use a quality vacuum indicator or manometer. This can be placed on the Schrader connections on each vessel by removing the evaporator or condenser pressure transducer (Fig. 5-7).
2. To determine pumpout storage tank pressure, a 30 in. Hg vacuum $-0-400$ psi (-101 kPa $-0-2769$ kPa) compound gage is attached to the storage tank.
3. Refer to Fig. 40-43 and 53, for valve locations and numbers.

CAUTION

Transfer, addition, or removal of refrigerant in spring-isolated chillers may place severe stress on external piping if springs have not been blocked in both up and down directions.

Operating the Optional Pumpout Unit

1. Be sure that the suction and the discharge service valves on the optional pumpout compressor are open

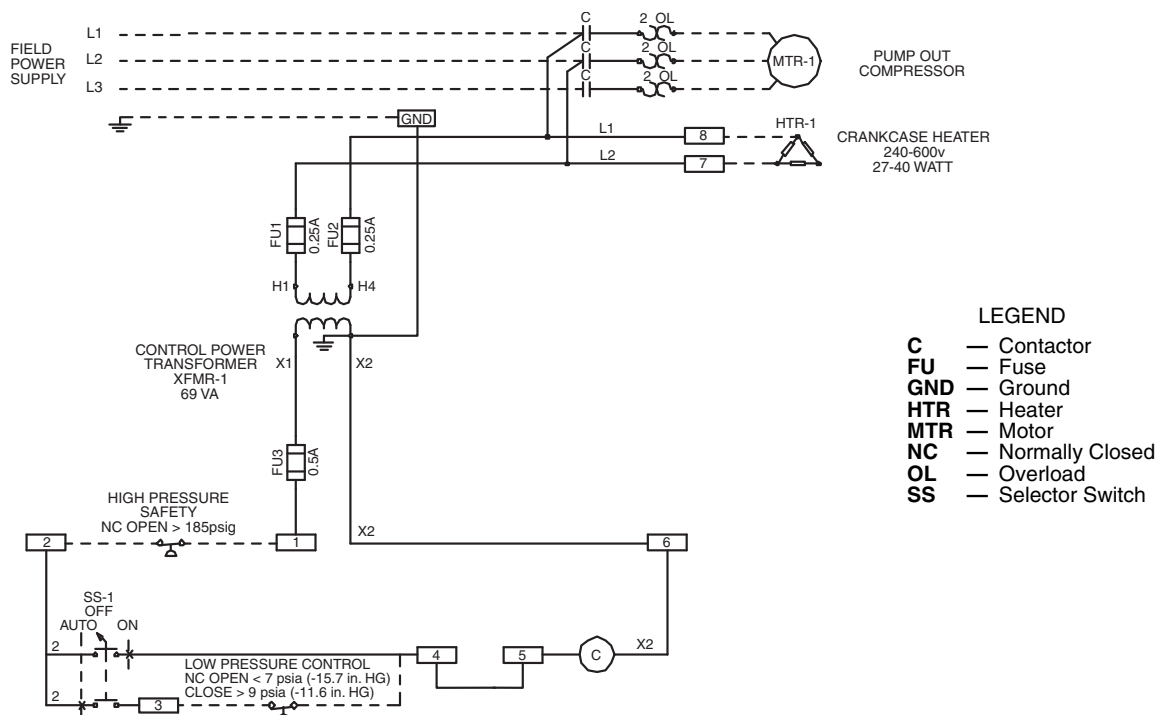

Fig. 52 — 23XRV Pumpout Unit Wiring Schematic

Chillers with Storage Tanks — In the Valve/Condition tables that accompany these instructions, the letter “C” indicates a closed valve. Figures 53-55 show the locations of the valves.

CAUTION

Always run chiller cooler and condenser water pumps and always charge or transfer refrigerant as a gas when chiller vessel pressure is less than 35 psig (241 kPa). Below these pressures, liquid refrigerant flashes into gas, resulting in extremely low temperatures in the cooler/condenser tubes and possibly causing tube freeze-up.

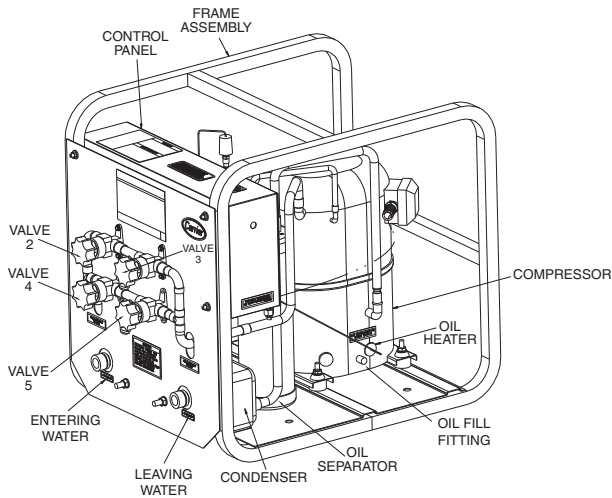

Fig. 53 —Optional Pumpout Unit

FOR UNITS WITH Q AND R COMPRESSORS ONLY

Transfer Refrigerant from Pumpout Storage Tank to Chiller

WARNING

During transfer of refrigerant into and out of the 23XRV storage tank, carefully monitor the storage tank level gage. Do not fill the tank more than 90% of capacity to allow for refrigerant expansion. Overfilling may result in damage to the tank and personal injury.

1. Equalize refrigerant pressure.
 - a. Turn on chiller water pumps, establishing water flow (assumes vacuum condition in chiller system).
 - b. Close pumpout and storage tank valves 2, 4, 5, 7, 8, 10 (if present open isolation valve 11 and other isolation valves between cooler and condenser). Open storage tank valves 6; open chiller valves 1A and 1B.

VALVE	1A	1B	2	3	4	5	6	7	8	10	11
CONDITION			C		C	C		C	C	C	

- c. Gradually open valve 5 to slowly increase chiller pressure to 35 psig (241 kPa) to reduce the potential of tube freeze up.

- a. To prepare for liquid push, turn off the pumpout condenser water. Place valves in the following

- d. Open valve 5 fully after the chiller pressure reaches 35 psig (241 kPa) or greater. Let chiller pressure reach 40 psig (276 kPa), then chiller water pumps can be turned off. Fully close valve 5.

VALVE	1A	1B	2	3	4	5	6	7	8	10	11
CONDITION			C		C	C		C	C	C	

- e. Open valve 8 and 10 to let higher pressure in the recovery tank push liquid refrigerant into the condenser float chamber and heat exchangers until the refrigerant pressure equalizes between the recovery tank and chiller.

VALVE	1A	1B	2	3	4	5	6	7	8	10	11
CONDITION			C		C	C		C			

2. Push liquid to chiller, then remove remaining vapor from storage tank:

- a. To prepare for liquid, push open valve 4.

VALVE	1A	1B	2	3	4	5	6	7	8	10	11
CONDITION			C			C		C			

- b. Ensure pumpout condenser water is off, then turn on the pumpout compressor in manual mode to push liquid to chiller. Monitor the storage tank level until tank is empty of liquid refrigerant.
- c. Close charging valves 8 and 10.
- d. Turn off the pumpout compressor.
- e. To prepare for removal of remaining refrigerant vapor in storage tank, close pumpout valves 3 and 4 and open valves 2 and 5.

VALVE	1A	1B	2	3	4	5	6	7	8	10	11
CONDITION				C	C			C	C	C	

- f. Turn on pumpout condenser water.
- g. Run pumpout unit in auto until the vacuum switch is satisfied. This occurs approximately at 15 in Hg vacuum (48 kPa absolute or 7 psia), removing the residual refrigerant vapor from the recovery tank and condensing to a liquid in the chiller.
- h. Close valves 1A, 1B, 2, 5, 6.

VALVE	1A	1B	2	3	4	5	6	7	8	10	11
CONDITION	C	C	C	C	C	C	C	C	C	C	

- i. Turn off pumpout condenser water.

Transfer Refrigerant from Chiller to Storage Tank Vessel

1. Equalize refrigerant pressure.
 - a. Dehydrate the refrigerant storage vessel, and connected hoses/piping so there are no non-condensables mixed with the refrigerant.
 - b. Locate valves as identified below:

VALVE	1A	1B	2	3	4	5	6	7	8	10	11
CONDITION			C		C	C		C	C	C	

- c. Slowly open valve 5 until the refrigerant pressure reaches 35 psig (241 kPa) in the storage tank, followed by valves 7 and 10 to allow liquid refrigerant to drain by gravity.

VALVE	1A	1B	2	3	4	5	6	7	8	10	11
CONDITION			C		C				C		

2. Push remaining liquid, followed by refrigerant vapor removal from chiller.

positions:

VALVE	1A	1B	2	3	4	5	6	7	8	10	11
-------	----	----	---	---	---	---	---	---	---	----	----

CONDITION				C	C					C		
-----------	--	--	--	---	---	--	--	--	--	---	--	--

- b. Run the pumpout compressor in manual until all liquid is pushed out of the chiller (approximately 45 minutes). Close valves 2, 5, 7, and 10, then stop compressor.

VALVE	1A	1B	2	3	4	5	6	7	8	10	11
CONDITION			C	C	C	C		C	C	C	

- c. Turn on pumpout condenser water.
d. Open valves 3 and 4, and place valves in the following positions:

VALVE	1A	1B	2	3	4	5	6	7	8	10	11
CONDITION			C			C		C	C	C	

- e. Run the pumpout compressor until the chiller pressure reaches 35 psig (241 kPa), followed by turning off the pumpout compressor. Warm chiller condenser water will boil off any entrapped liquid refrigerant, and chiller pressure will rise.
f. When chiller pressure rises to 40 psig (276 kPa), turn on the pumpout compressor until the pressure reaches 35 psig (241 kPa) again; then turn off the pumpout compressor. Repeat this process until the chiller pressure no longer rises.
g. Start the chiller water pumps (condenser and cooler), establishing water flow. At this point, turn on the pumpout compressor in auto until the vacuum switch is satisfied. This occurs at approximately 15 in Hg vacuum (48 kPa absolute or 7 psia).
h. Close valves.

VALVE	1A	1B	2	3	4	5	6	7	8	10	11
CONDITION	C	C	C	C	C	C	C	C	C	C	C

- i. Turn off the pumpout condenser water.

Chillers with Isolation Valves.— The valves referred to in the following instructions are shown in Fig. 54 and 55. The cooler/condenser vessels can be used for refrigerant isolation for certain service conditions when the isolation valve package is specified.

Transfer Refrigerant from Cooler to Condenser

- a. Turn off chiller water pumps and pumpout condenser water supply (if applicable). It is assumed that the starting point is as shown in the following table and that pressures in both vessels are above 35 psig (241 kPa).

VALVE	1A	1B	2	3	4	5	7	8	11
CONDITION	C	C	C	C	C	C	C	C	C

- b. Keeping valves 7 and 8 closed, install charging hose from liquid line charging valve 7 to valve 8 on the condenser float chamber. Evacuate or purge hose of non-condensables. Note that this creates a flow path between cooler and condenser that bypasses the linear float, reducing the potential for damage during refrigerant transfer.

- c. Open valves 1A, 1B, 2, 5, and 8.

VALVE	1A	1B	2	3	4	5	7	8	11
CONDITION				C	C		C		C

- d. Turn on pumpout compressor, generating a refrigerant pressure differential of 10 to 20 psi (69 to 138 kPa) to push liquid out of the chiller cooler vessel.
e. Slowly open valve 7 to allow liquid transfer. Rapid opening of valve 7 can result in float valve damage.
f. When all liquid has been pushed into the chiller condenser vessel, close valve 8.

VALVE	1A	1B	2	3	4	5	7	8	11
CONDITION				C	C			C	C

- g. Turn off the pumpout compressor.
h. Close pumpout valves 2 and 5 while opening valve 3 and 4 to prepare for removal of remaining refrigerant vapor in cooler vessel.

VALVE	1A	1B	2	3	4	5	7	8	11
CONDITION			C			C		C	C

- i. Turn on pumpout condenser water.
j. Turn on pumpout compressor. Turn on the chiller water pump to establish water flow when the cooler refrigerant pressure is 35 psig (241 kPa). **The water pumps have to be in operation whenever the refrigerant pressure is equal to or less than 35 psig (241 kPa) to reduce the potential of tube damage.**
k. Run the pumpout compressor until the cooler pressure reaches 35 psig (241 kPa), then turn off the pumpout compressor. Warm chiller cooler water will boil off any entrapped liquid refrigerant, and chiller pressure will rise. Repeat this process until the chiller pressure no longer rises.
l. Run pumpout unit in auto until the vacuum switch is satisfied; this occurs at approximately 15 in. Hg vacuum (48 kPa absolute or 7 psia). Close valve 1A.

VALVE	1A	1B	2	3	4	5	7	8	11
CONDITION	C		C			C		C	C

- m. Monitor that cooler pressure does not rise (if it does, then repeat previous step).
n. With service valve 1A closed, shut down pumpout compressor (if still running).
o. Close remaining valves.

VALVE	1A	1B	2	3	4	5	7	8	11
CONDITION	C	C	C	C	C	C	C	C	C

- p. Remove charging hose between 7 and 8 (evacuate prior to removal).
q. Turn off pumpout condenser water.
r. Turn off chiller water pumps, and lockout chiller compressor.

Transfer Refrigerant from Condenser to Cooler

- a. Turn off chiller water pumps and pumpout condenser water supply (if applicable). It is assumed that the starting point is as shown in the following table and that pressures in both vessels are above 35 psig (241 kPa).

VALVE	1A	1B	2	3	4	5	7	8	11
CONDITION	C	C	C	C	C	C	C	C	C

- b. Set valves as shown below to allow the refrigerant to equalize:

VALVE	1A	1B	2	3	4	5	7	8	11
CONDITION			C			C	C	C	C

- c. Turn on pumpout compressor, and develop a 10 to 20 psi (69 to 138 kPa) refrigerant differential pressure between the vessels.
- d. Partially open valve 11 while maintaining a refrigerant pressure differential to push liquid refrigerant out of the chiller condenser to the cooler.
- e. When all liquid is out of the chiller condenser, close valve 11 and any other isolation valves on the chiller.
- f. Turn off the pumpout compressor.
- g. Close pumpout valves 3 and 4 while opening valve 2 and 5 to prepare for removal of remaining refrigerant vapor in condenser vessel.

VALVE	1A	1B	2	3	4	5	7	8	11
CONDITION				C	C		C	C	C

- h. Turn on pumpout condenser water.
- i. Turn on pumpout compressor.
- j. Turn on the chiller water pumps, establishing water flow when the condenser refrigerant pressure is 35 psig (241 kPa). **The water pumps have to be in operation whenever the refrigerant pressure is equal to or less than 35 psig (241 kPa) to reduce the potential of tube damage.**
- k. Run the pumpout compressor until the condenser refrigerant pressure reaches 35 psig (241 kPa) then turn off the pumpout compressor. Warm condenser water will boil off any entrapped liquid refrigerant, and chiller pressure will rise. Repeat this process until the chiller pressure no longer rises.
- l. Run pumpout unit in auto until the vacuum switch is satisfied; this occurs at approximately 15 in. Hg vacuum (48 kPa absolute or 7 psia). Close valve 1B.

VALVE	1A	1B	2	3	4	5	7	8	11
CONDITION		C		C	C		C	C	C

- m. Monitor that condenser pressure does not rise (if it does, then repeat previous step).
- n. With service valve 1B closed, shut down pumpout compressor (if still running).
- o. Close remaining valves.

VALVE	1A	1B	2	3	4	5	7	8	11
CONDITION	C	C	C	C	C	C	C	C	C

- p. Turn off pumpout condenser water.
- q. Turn off chiller water pumps, and lock out chiller compressor.

Return Chiller to Normal Operating Conditions

- Vapor Pressure Equalization:
 - Ensure that the chiller vessel that was exposed to ambient has been evacuated. Final vacuum prior to charging with refrigerant should in all cases be 29.9 in. Hg (500 microns, 0.07 kPa [abs]) or less.
 - Turn on chiller water pumps.
 - Open valves 1A, 1B, and 2.

VALVE	1A	1B	2	3	4	5	7	8	11
CONDITION				C	C	C	C	C	C

- Slowly open valve 4, gradually increasing pressure in the evacuated vessel to 35 psig (241 kPa).
- Leak test to ensure chiller vessel integrity.
- Open valve 4 fully for cooler and condenser pressure equalization (vapor equalization).

VALVE	1A	1B	2	3	4	5	7	8	11
CONDITION				C		C	C	C	C

- g. Close valves 1A, 1B, 2, and 4.

VALVE	1A	1B	2	3	4	5	7	8	11
CONDITION	C	C	C	C	C	C	C	C	C

2. Liquid equalization:

- If refrigerant is stored in cooler, install a charging hose between valves 7 and 8, and open both the valves and any other isolation valves (except valve 11) for liquid to drain into the condenser while bypassing the linear float valve. If refrigerant is stored in the condenser, keep valve 11 and any other isolation valves open for liquid drain.

VALVE	1A	1B	2	3	4	5	7	8	11
CONDITION (CHARGE IN COOLER)	C	C	C	C	C	C			C
CONDITION (CHARGE IN CONDENSER)	C	C	C	C	C	C	C	C	

- If valves 7 and 8 were used to bypass the linear float valve, once the liquid transfer is complete, close these valves, and slowly open valve 11.
- Turn off chiller water pumps.

Distilling the Refrigerant

- Transfer the refrigerant from the chiller to the pumpout storage tank as described in the Transfer Refrigerant from Chiller to Storage Tank Vessel section.
- Equalize the refrigerant pressure.
 - Turn on chiller water pumps and monitor chiller pressures.
 - Close pumpout and storage tank valves 2, 4, 5, and 10, and close chiller charging valve 7; open chiller isolation valve 11 and any other chiller isolation valves, if present.
 - Open pumpout and storage tank valves 3 and 6; open chiller valves 1A and 1B.

VALVE	1A	1B	2	3	4	5	6	7	10	11
CONDITION			C		C	C		C	C	

- Gradually crack open valve 5 to increase chiller pressure to 35 psig (241 kPa). Slowly feed refrigerant to prevent freeze-up.
 - Open valve 5 fully after the chiller pressure rises above the freezing point of the refrigerant. Let the storage tank and chiller pressure equalize.
- Transfer remaining refrigerant.
 - Close valve 3.
 - Open valve 2.

VALVE	1A	1B	2	3	4	5	6	7	10	11
CONDITION				C	C			C	C	

- Turn on pumpout condenser water.
- Run the pumpout compressor until the storage tank pressure reaches 5 psig (34 kPa), 18 in. Hg vacuum (41 kPa absolute) in Manual or Automatic mode.
- Turn off the pumpout compressor.

- f. Close valves 1A, 1B, 2, 5, and 6.
- g. Turn off pumpout condenser water.

- h. Drain the contaminants from the bottom of the storage tank into a container. Dispose of contaminants safely.

VALVE	1A	1B	2	3	4	5	6	7	10	11
CONDITION	C	C	C	C	C	C	C	C	C	C

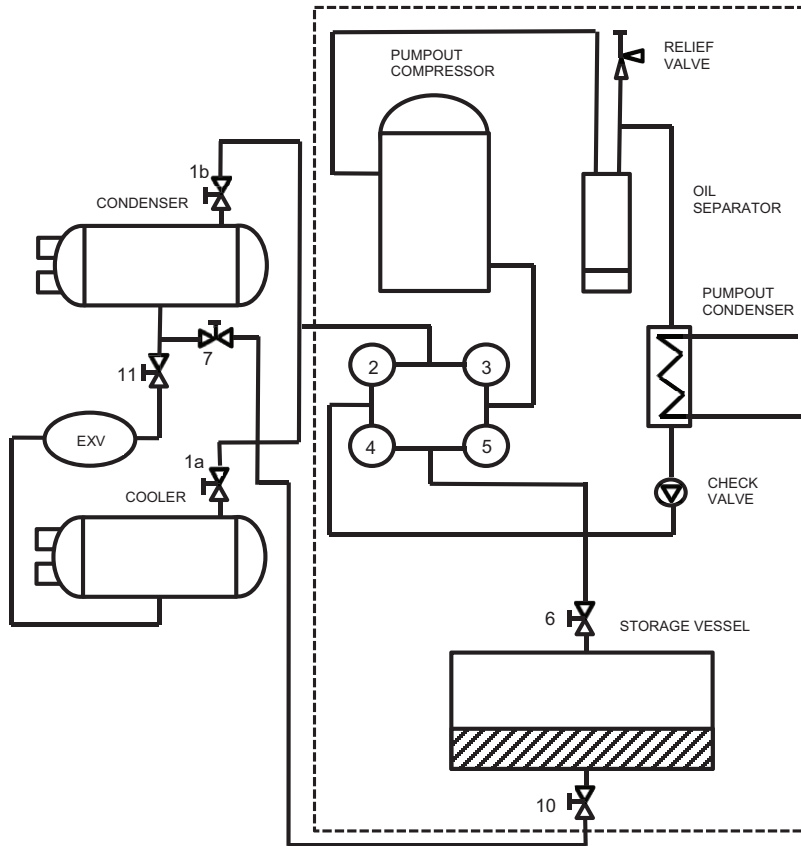

Fig. 54 — Pumpout System Piping Schematic with Storage Tank for 23XRV Units with Q or R Compressors

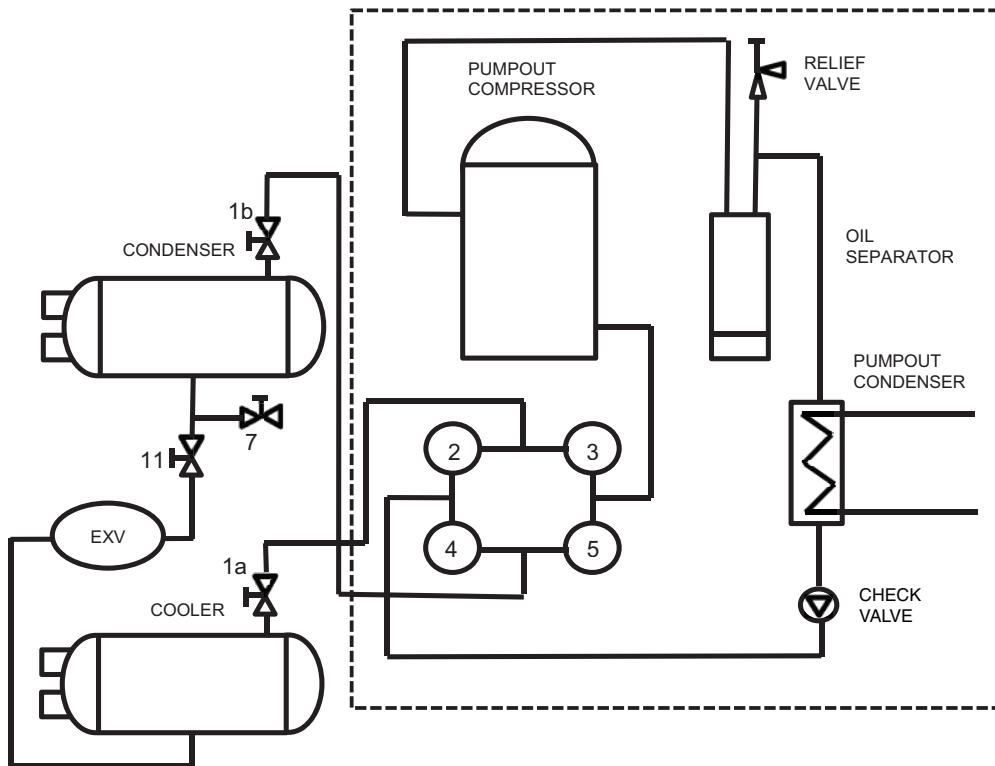

Fig. 55 — Pumpout System Piping Schematic without Storage Tank for 23XRV Units with Q or R Compressors

UNITS WITH P COMPRESSORS ONLY

Transfer Refrigerant from Pumpout Storage Tank to Chiller

⚠ WARNING
During transfer of refrigerant into and out of the 23XRV storage tank, carefully monitor the storage tank level gage. Do not fill the tank more than 90% of capacity to allow for refrigerant expansion. Overfilling may result in damage to the tank and personal injury.

1. Equalize refrigerant pressure.
 - a. Turn on chiller water pumps, establishing water flow (assumes vacuum condition in chiller system).
 - b. Close pumpout and storage tank valves 2, 4, 5, 7, 10 (if present open isolation valve 11 and other isolation valves between cooler and condenser). Open storage tank valves 6; open chiller valves 1A and 1B.

VALVE	1A	1B	2	3	4	5	6	7	10	11
CONDITION			C		C	C		C	C	

- c. Gradually open valve 5 to slowly increase chiller pressure to 35 psig (241 kPa) to reduce the potential of tube freeze up.
 - d. Open valve 5 fully after the chiller pressure reaches 35 psig (241 kPa) or greater. Let chiller pressure reach 40 psig (276 kPa), then chiller water pumps can be turned off. Fully close valve 5.

VALVE	1A	1B	2	3	4	5	6	7	10	11
CONDITION			C		C	C		C	C	

- e. Open valve 7 and 10 to let higher pressure in the recovery tank push liquid refrigerant into the condenser float chamber and heat exchangers until the refrigerant pressure equalizes between the recovery tank and chiller.

VALVE	1A	1B	2	3	4	5	6	7	10	11
CONDITION			C		C	C				

2. Push liquid to chiller, then remove remaining vapor from storage tank:
 - a. To prepare for liquid, push open valve 4.

VALVE	1A	1B	2	3	4	5	6	7	10	11
CONDITION			C			C				

- b. Ensure pumpout condenser water is off, then turn on the pumpout compressor in manual mode to push liquid to chiller. Monitor the storage tank level until tank is empty of liquid refrigerant.
 - c. Close charging valves 7 and 10.
 - d. Turn off the pumpout compressor.
 - e. To prepare for removal of remaining refrigerant vapor in storage tank, close pumpout valves 3 and 4 and open valves 2 and 5.

VALVE	1A	1B	2	3	4	5	6	7	10	11
CONDITION				C	C			C	C	

- f. Turn on pumpout condenser water.
 - g. Run pumpout unit in auto until the vacuum switch is satisfied. This occurs approximately at 15 in Hg vacuum (48 kPa absolute or 7 psia), removing the

residual refrigerant vapor from the recovery tank and condensing to a liquid in the chiller.

- h. Close valves 1A, 1B, 2, 5, 6.

VALVE	1A	1B	2	3	4	5	6	7	10	11
CONDITION	C	C	C	C	C	C	C	C	C	

- i. Turn off pumpout condenser water.

Transfer Refrigerant from Chiller to Storage Tank Vessel

1. Equalize refrigerant pressure.
 - a. Dehydrate the refrigerant storage vessel, and connected hoses/piping so there are no non-condensables mixed with the refrigerant.
 - b. Locate valves as identified below:

VALVE	1A	1B	2	3	4	5	6	7	10	11
CONDITION			C		C	C		C	C	

- c. Slowly open valve 5 until the refrigerant pressure reaches 35 psig (241 kPa) in the storage tank, followed by valves 7 and 10 to allow liquid refrigerant to drain by gravity.

VALVE	1A	1B	2	3	4	5	6	7	10	11
CONDITION			C		C					

2. Push remaining liquid, followed by refrigerant vapor removal from chiller.
 - a. To prepare for liquid push, turn off the pumpout condenser water. Place valves in the following positions:

VALVE	1A	1B	2	3	4	5	6	7	10	11
CONDITION				C	C					

- b. Run the pumpout compressor in manual until all liquid is pushed out of the chiller (approximately 45 minutes). Close valves 2, 5, 7, and 10, then stop compressor.

VALVE	1A	1B	2	3	4	5	6	7	10	11
CONDITION			C	C	C	C		C	C	

- c. Turn on pumpout condenser water.
 - d. Open valves 3 and 4, and place valves in the following positions:

VALVE	1A	1B	2	3	4	5	6	7	10	11
CONDITION			C			C		C	C	

- e. Run the pumpout compressor until the chiller pressure reaches 35 psig (241 kPa), followed by turning off the pumpout compressor. Warm chiller condenser water will boil off any entrapped liquid refrigerant, and chiller pressure will rise.
 - f. When chiller pressure rises to 40 psig (276 kPa), turn on the pumpout compressor until the pressure reaches 35 psig (241 kPa) again; then turn off the pumpout compressor. Repeat this process until the chiller pressure no longer rises.
 - g. Start the chiller water pumps (condenser and cooler), establishing water flow. At this point, turn on the pumpout compressor in auto until the vacuum switch is satisfied. This occurs at approximately 15 in Hg vacuum (48 kPa absolute or 7 psia).
 - h. Close valves.

VALVE	1A	1B	2	3	4	5	6	7	10	11
CONDITION	C	C	C	C	C	C	C	C	C	

- i. Turn off the pumpout condenser water.

Chillers with Isolation Valves — The valves referred to in the following instructions are shown in Fig. 54 and 55. The cooler/condenser vessels can be used for refrigerant isolation for certain service conditions when the isolation valve package is specified.

Transfer Refrigerant from Cooler to Condenser

- a. Turn off chiller water pumps and pumpout condenser water supply (if applicable). It is assumed that the starting point is as shown in the following table and that pressures in both vessels are above 35 psig (241 kPa).

VALVE	1A	1B	2	3	4	5	7	11
CONDITION	C	C	C	C	C	C	C	C

- b. Open valves 1A, 1B, 2, and 5.

VALVE	1A	1B	2	3	4	5	7	11
CONDITION				C	C		C	C

- c. Turn on pumpout compressor, generating a refrigerant pressure differential of 10 to 20 psi (69 to 138 kPa) to push liquid out of the chiller cooler vessel.
- d. Slowly open valve 11 to allow liquid transfer.
- e. When all liquid has been pushed into the chiller condenser vessel, close valve 11.

VALVE	1A	1B	2	3	4	5	7	11
CONDITION				C	C		C	C

- f. Turn off the pumpout compressor.
- g. Close pumpout valves 2 and 5 while opening valve 3 and 4 to prepare for removal of remaining refrigerant vapor in cooler vessel.

VALVE	1A	1B	2	3	4	5	7	11
CONDITION			C			C	C	C

- h. Turn on pumpout condenser water.
- i. Turn on pumpout compressor. Turn on the chiller water pump to establish water flow when the cooler refrigerant pressure is 35 psig (241 kPa). **The water pumps have to be in operation whenever the refrigerant pressure is equal to or less than 35 psig (241 kPa) to reduce the potential of tube damage.**
- j. Run the pumpout compressor until the cooler pressure reaches 35 psig (241 kPa), then turn off the pumpout compressor. Warm chiller cooler water will boil off any entrapped liquid refrigerant, and chiller pressure will rise. Repeat this process until the chiller pressure no longer rises.
- k. Run pumpout unit in auto until the vacuum switch is satisfied; this occurs at approximately 15 in. Hg vacuum (48 kPa absolute or 7 psia). Close valve 1A.

VALVE	1A	1B	2	3	4	5	7	11
CONDITION	C		C			C	C	C

- l. Monitor that cooler pressure does not rise (if it does, then repeat previous step).
- m. With service valve 1A closed, shut down pumpout compressor (if still running).
- n. Close remaining valves.

VALVE	1A	1B	2	3	4	5	7	11
CONDITION	C	C	C	C	C	C	C	C

- o. Turn off pumpout condenser water.

- p. Turn off chiller water pumps, and lockout chiller compressor.

Transfer Refrigerant from Condenser to Cooler

- a. Turn off chiller water pumps and pumpout condenser water supply (if applicable). It is assumed that the starting point is as shown in the following table and that pressures in both vessels are above 35 psig (241 kPa).

VALVE	1A	1B	2	3	4	5	7	11
CONDITION	C	C	C	C	C	C	C	C

- b. Set valves as shown below to allow the refrigerant to equalize:

VALVE	1A	1B	2	3	4	5	7	11
CONDITION			C			C	C	C

- c. Turn on pumpout compressor, and develop a 10 to 20 psi (69 to 138 kPa) refrigerant differential pressure between the vessels.
- d. Partially open valve 11 while maintaining a refrigerant pressure differential to push liquid refrigerant out of the chiller condenser to the cooler.
- e. When all liquid is out of the chiller condenser, close valve 11 and any other isolation valves on the chiller.
- f. Turn off the pumpout compressor.
- g. Close pumpout valves 3 and 4 while opening valve 2 and 5 to prepare for removal of remaining refrigerant vapor in condenser vessel.

VALVE	1A	1B	2	3	4	5	7	11
CONDITION				C	C		C	C

- h. Turn on pumpout condenser water.
- i. Turn on pumpout compressor.
- j. Turn on the chiller water pumps, establishing water flow when the condenser refrigerant pressure is 35 psig (241 kPa). **The water pumps have to be in operation whenever the refrigerant pressure is equal to or less than 35 psig (241 kPa) to reduce the potential of tube damage.**
- k. Run the pumpout compressor until the condenser refrigerant pressure reaches 35 psig (241 kPa) then turn off the pumpout compressor. Warm condenser water will boil off any entrapped liquid refrigerant, and chiller pressure will rise. Repeat this process until the chiller pressure no longer rises.
- l. Run pumpout unit in auto until the vacuum switch is satisfied; this occurs at approximately 15 in. Hg vacuum (48 kPa absolute or 7 psia). Close valve 1B.

VALVE	1A	1B	2	3	4	5	7	11
CONDITION		C		C	C		C	C

- m. Monitor that condenser pressure does not rise (if it does, then repeat previous step).
- n. With service valve 1B closed, shut down pumpout compressor (if still running).
- o. Close remaining valves.

VALVE	1A	1B	2	3	4	5	7	11
CONDITION	C	C	C	C	C	C	C	C

- p. Turn off pumpout condenser water.
- q. Turn off chiller water pumps, and lock out chiller compressor.

Return Chiller to Normal Operating Conditions

1. Vapor Pressure Equalization:
 - a. Ensure that the chiller vessel that was exposed to ambient has been evacuated. Final vacuum prior to charging with refrigerant should in all cases be 29.9 in. Hg (500 microns, 0.07 kPa [abs]) or less.
 - b. Turn on chiller water pumps.
 - c. Open valves 1A, 1B, and 2.

VALVE	1A	1B	2	3	4	5	7	11
CONDITION				C	C	C	C	C

- d. Slowly open valve 4, gradually increasing pressure in the evacuated vessel to 35 psig (241 kPa).
- e. Leak test to ensure chiller vessel integrity.
- f. Open valve 4 fully for cooler and condenser pressure equalization (vapor equalization).

VALVE	1A	1B	2	3	4	5	7	11
CONDITION				C		C	C	C

- g. Close valves 1A, 1B, 2, and 4.

VALVE	1A	1B	2	3	4	5	7	11
CONDITION	C	C	C	C	C	C	C	C

2. Liquid equalization:
 - a. Slowly open valve 11 and any other isolation valves open for liquid drain.

VALVE	1A	1B	2	3	4	5	7	11
CONDITION	C	C	C	C	C	C	C	

- b. Turn off chiller water pumps.

Distilling the Refrigerant

1. Transfer the refrigerant from the chiller to the pumpout storage tank as described in the Transfer Refrigerant from Chiller to Storage Tank Vessel section.
2. Equalize the refrigerant pressure.
 - a. Turn on chiller water pumps and monitor chiller pressures.
 - b. Close pumpout and storage tank valves 2, 4, 5, and 10, and close chiller charging valve 7; open chiller isolation valve 11 and any other chiller isolation valves, if present.
 - c. Open pumpout and storage tank valves 3 and 6; open chiller valves 1A and 1B.

VALVE	1A	1B	2	3	4	5	6	7	10	11
CONDITION			C		C	C			C	C

- d. Gradually crack open valve 5 to increase chiller pressure to 35 psig (241 kPa). Slowly feed refrigerant to prevent freeze-up.
- e. Open valve 5 fully after the chiller pressure rises above the freezing point of the refrigerant. Let the storage tank and chiller pressure equalize.

3. Transfer remaining refrigerant.
 - a. Close valve 3.
 - b. Open valve 2.

VALVE	1A	1B	2	3	4	5	6	7	10	11
CONDITION				C	C				C	C

- c. Turn on pumpout condenser water.
- d. Run the pumpout compressor until the storage tank pressure reaches 5 psig (34 kPa), 18 in. Hg vacuum (41 kPa absolute) in Manual or Automatic mode.
- e. Turn off the pumpout compressor.

- f. Close valves 1A, 1B, 2, 5, and 6.
- g. Turn off pumpout condenser water.

VALVE	1A	1B	2	3	4	5	6	7	10	11
CONDITION	C	C	C	C	C	C	C	C	C	

Drain the contaminants from the bottom of the storage tank into a container. Dispose of contaminants safely.

GENERAL MAINTENANCE

Refrigerant Properties — HFC-134a is the standard refrigerant in the 23XRV chiller. At normal atmospheric pressure, HFC-134a will boil at -14 F (-25 C), and must, therefore, be kept in pressurized containers or storage tanks. The refrigerant is practically odorless when mixed with air. HFC-134a is non-combustible at atmospheric pressure. Read the Material Safety Data Sheet and the latest ASHRAE Safety Guide for Mechanical Refrigeration to learn more about safe handling of this refrigerant.

⚠ WARNING

HFC-134a will dissolve oil and some non-metallic materials, dry the skin, and, in heavy concentrations, may displace enough oxygen to cause asphyxiation. In handling this refrigerant, protect the hands and eyes and avoid breathing fumes.

Adding Refrigerant — Follow the procedures described in the Charge Refrigerant into Chiller section, page 79.

⚠ CAUTION

Always use the compressor pumpdown function in the Control Test mode to turn on the evaporator pump and lock out the compressor when transferring refrigerant. Liquid refrigerant may flash into a gas and cause possible freeze-up when the chiller pressure is below 35 psig (241 kPa).

Removing Refrigerant — If the optional pumpout system is used, the 23XRV refrigerant charge may be transferred to a storage vessel or within the condenser or cooler if isolation valves are present. Follow procedures in the Pumpout and Refrigerant Transfer Procedures section when removing refrigerant from the storage tank to the chiller.

Adjusting the Refrigerant Charge — If the addition or removal of refrigerant is required for improved chiller performance, follow the procedures given under the Trim Refrigerant Charge section, on page 94.

Refrigerant Leak Testing — Because HFC-134a is above atmospheric pressure at room temperature, leak testing can be performed with refrigerant in the chiller. Use an electronic leak detector, halide leak detector, soap bubble solution, or ultra-sonic leak detector. Be sure that the room is well ventilated and free from concentration of refrigerant to keep false readings to a minimum. Before making any necessary repairs to a leak, transfer all refrigerant from the leaking vessel. The chiller should be leak tested at least once per year.

Refrigerant Leak Rate — ASHRAE recommends that chillers should be immediately taken off line and repaired if the refrigerant leakage rate for the entire chiller is more than 10% of the operating refrigerant charge per year.

Additionally, Carrier recommends that leaks totaling less than the above rate but more than a rate of 1 lb (0.5 kg) per year should be repaired during annual maintenance or whenever the refrigerant is pumped over for other service work.

Test After Service, Repair, or Major Leak — If all refrigerant has been lost or if the chiller has been opened for service, the chiller or the affected vessels must be pressurized and leak tested. Refer to the Leak Test Chiller section to perform a leak test.

REFRIGERANT TRACER — Use an environmentally acceptable refrigerant as a tracer for leak test procedures.

TO PRESSURIZE WITH DRY NITROGEN — Another method of leak testing is to pressure with nitrogen only and use soap bubble solution or an ultrasonic leak detector to determine if leaks are present. This should only be done if all refrigerant has been evacuated from the vessel.

1. Connect a copper tube from the pressure regulator on the cylinder to the refrigerant charging valve. Never apply full cylinder pressure to the pressurizing line. Follow the listed sequence.
2. Open the charging valve fully.
3. Slowly open the cylinder regulating valve.
4. Observe the pressure gage on the chiller and close the regulating valve when the pressure reaches test level. Do not exceed 140 psig (965 kPa).
5. Close the charging valve on the chiller. Remove the copper tube if no longer required.

Repair the Refrigerant Leak, Retest, and Apply Standing Vacuum Test — After pressurizing the chiller, test for leaks with a soap bubble solution, an electronic leak detector, a halide torch, or an ultrasonic leak detector. Bring the chiller back to atmospheric pressure, repair any leaks found, and retest.

After retesting and finding no leaks, apply a standing vacuum test. Then dehydrate the chiller. Refer to the Chiller Dehydration in the Before Initial Start-Up section, page 71.

Trim Refrigerant Charge — If it becomes necessary to adjust the refrigerant charge to obtain optimum chiller performance, operate the chiller at design load and then add or remove refrigerant slowly until the difference between *LEAVING CHILLED LIQUID* chilled liquid temperature and the *EVAP REFRIG LIQUID TEMP* reaches design conditions. Do not overcharge. For superheat information, see the Troubleshooting Guide section on page 100.

Refrigerant may be added either through the optional storage tank or directly into the chiller as described in the section entitled, Refrigerant Charging.

To remove any excess refrigerant, follow the procedure in Transfer Refrigerant from Chiller to Storage Tank Vessel section, Steps 1a, b on page 91.

WEEKLY MAINTENANCE

Check the Lubrication System — Mark the oil level on the oil sump sight glasses and observe the level each week while the chiller is running. Check the moisture indicator on the motor cooling line.

If the level goes below the bottom of the oil sump sight glass, the oil reclaim system will need to be checked for proper operation. The oil reclaim system is operating properly if the level in the oil sump increases after running the chiller near full load with a 95 F (35 C) or higher *CONDENSER TEMPERATURE* for 1 hour. If additional oil is required, add it through the oil charging valve (Fig. 2-7). A hand pump is required for adding oil against refrigerant pressure. The oil charge for the 23XRV chiller is 7.5 gallons (28 L).

The oil *must* meet Carrier's specifications for the 23XRV chillers. Refer to Changing Oil and Oil Filter section. Any oil that is added should be logged by noting the amount and date in Fig. 51 on page 85. Any oil that is added due to oil loss not related to service will eventually return to the sump. Excess oil

must be removed when the level is above the top of the oil sump sight glass.

A 530-watt oil sump heater is controlled by the PIC III controls to maintain oil temperature above 140 F (60 C) or *CALC EVAP SAT TEMP* plus 53 F (29.4 C) when the compressor is off (see the Controls section on page 18). The ICVC Status COMPRESS table displays whether the heater is energized or not. If the PIC III controls show that the sump heater is energized, but the sump is not heating up, the power to the oil sump heater may be off or the oil level may be too low. Check the oil level, the sump oil heater contactor voltage, and oil heater resistance.

The PIC III controls will not permit compressor start-up if the oil temperature is less than 140 F (60 C) or *CALC EVAP SAT TEMP* plus 15 F (8.3 C), whichever is lower. The control will continue with start-up only after the temperature is within limits.

SCHEDULED MAINTENANCE

Establish a regular maintenance schedule based on the actual chiller requirements such as chiller load, run hours, and cooler and condenser liquid quality. The time intervals listed in this section are offered as guides to service only. Jobsite conditions may dictate that maintenance schedule is performed more often than recommended.

NOTE: The Optional Extended Warranty includes specific maintenance requirements and service intervals that must be documented. See specific details in the Optional Extended Warranty agreement.

Service Ontime — The ICVC will display a *SERVICE ONTIME* value on the MAINSTAT table. This value should be reset to zero by the service person or the operator each time major service work is completed so that time between service can be seen.

Inspect the Control Center — Maintenance is generally limited to general cleaning and tightening of connections. Vacuum the control center enclosure to eliminate dust build-up. In the event of chiller control malfunctions, refer to the Troubleshooting Guide section for control checks and adjustments.

Power connections on newly installed equipment may relax and loosen after a month of operation. Turn off power and re-tighten, check annually thereafter.

⚠ DANGER

Be sure power to the control center is off when cleaning and tightening connections inside the control center. Failure to be sure power is off will result in severe personal injury or death.

Check Safety and Operating Controls Monthly — To ensure chiller protection, the Automated Control Test in the service menu should be done at least once per month. See Table 5 for safety control settings.

⚠ CAUTION

Do not manually open the oil reclaim isolation valve when the chiller is shut down. Doing so will flood the vaporizer with refrigerant and severely degrade the viscosity of the oil in the sump.

Changing Oil and Oil Filter — If the *OIL PRESSURE DELTA P* approaches the 18 psid (124 kPa) *LOW OIL PRESSURE ALARM* threshold, change oil filter as needed. Otherwise, change the oil filter on a two year schedule.

Oil analysis is an important part of a good preventive maintenance program. Carrier recommends a yearly oil analysis. Changing oil is not recommended unless the oil analysis indicates problems. (The Optional Extended Warranty program has specific requirements.) If no analysis is being performed, change the oil after 5 years. See Oil Specification section below for additional information.

⚠ CAUTION

Compressor oil is hygroscopic. Containers should remain tightly sealed in a clean and dry environment to prevent moisture absorption from the air.

CHANGING OIL — The 23XRV oil pump and filter can be isolated to change the oil filter and oil while the refrigerant remains inside the chiller. Use the following procedures to change the oil and oil filter (if required):

1. Make sure the compressor is off and the CB1 main circuit breaker for the control center is open.
2. Open the CB2 control power and oil heater circuit breaker in order to turn off the power to the oil heater.
3. Record the oil level observed in the oil sump sight glass.

⚠ CAUTION

Be sure the power to the oil heater is off when the oil sump is drained. If the oil heater remains energized when the sump is empty, it will overheat any residual oil on the heating element and become fouled. Overheating the elements will also significantly reduce their useful life.

4. Connect an oil charging hose to the oil drain valve on the strainer housing. See Fig. 5-7. Place the other end of the oil charging hose in a clean container suitable for used oil. A portion of the oil drained from the sump should be used as an oil sample and should be sent to a laboratory for proper analysis. *Do not contaminate this sample.*
5. Slowly open the drain valve in order to drain the oil from the sump.

⚠ WARNING

The oil sump is at high pressure. Relieve pressure slowly to prevent injury.

6. Charge new oil through the drain valve on the strainer housing. A hand pump or portable electric oil pump will be required to charge oil back into the oil sump against refrigerant pressure.
7. Add oil (approximately 10 gal [38 L]) until it returns to the level noted in Step 3. The oil sight glass will not fill completely since a small amount of gas will be trapped inside (even under vacuum conditions).
8. Apply power through the CB2 controls and oil heater circuit breaker.

Changing Oil Filter

1. Make sure the compressor is off and the disconnect for the compressor starter is open.
2. Close both oil filter isolation valves. See Fig. 56.
3. Place a container underneath the oil filter assembly.
4. When a Schrader valve is provided, use it to relieve the pressure. Slowly open the drain plug, located on the bottom of the oil filter housing, to relieve pressure. *Do not remove the plug.*

5. Remove the filter canisters by unscrewing the retainer nut. The filter may now be removed and disposed of properly.
6. Install new oil filter. Install the new O-ring. Tighten the retainer nut.
7. If a Schrader valve is supplied, evacuate the oil filter by connecting the vacuum pump to the Schrader valve.
8. Slowly open the isolation valve located near the oil pump to equalize the pressure. Fully open both oil filter isolation valves.

Oil Specification — If oil is to be added, it must meet the following Carrier specifications:

- Carrier Part Number PP23BZ110001 (1x1 gal. can)
 PP23BZ110005 (1x5 gal. can)
- Oil type Inhibited polyolester-based synthetic compressor lubricant suitable for use in screw compressors where high viscosity and compatibility with HFC-134a refrigerants is required.
- ISO Viscosity Grade 220
- Specific Gravity 0.981
- Viscosity, cSt at 40 C (104 F) 198 to 242
 cSt at 100 C (212 F) 18 to 21
 SSU at 100 F (38 C) 1005 ± 100
 SSU at 210 F (99 C) 91 ± 7
- Pour Point (maximum) -6 F (-21 C)
- Flash Point (minimum) 428 F (220 C)
- Moisture Content (maximum) 50 ppm
- Acid Number (maximum) 0.15 mg KOH/gram
- Critical Solution Temperature with HFC-134a (maximum)
 -8 F (-22 C)

⚠ CAUTION

Compressor oil is hygroscopic. Containers should remain tightly sealed in a clean and dry environment to prevent moisture absorption from the air.

This oil (part number PP23BZ110001 [1x1 gal. can] and PP23BZ110005 [1x5 gal. can]) may be ordered from your local Carrier representative.

Oil Heater — Inspect the oil heater for carbon build-up on the heating element if an adequate oil sump temperature cannot be maintained when the chiller is shut down. It may be necessary to temporarily install the heater element terminal cover to provide additional leverage while threading the oil heater into the sump. The sump oil heater elements must be positioned vertically to allow proper heat convection. See Fig. 56 and 57. The heater element must be installed with the word “TOP” on the threaded fitting facing upward.

Refrigerant Filter/Drier — A refrigerant filter/drier, located on the motor cooling line, should be changed once every two years, or as necessary, if the condition of the filter indicates a need for less or more frequent replacement (see Fig. 58). A moisture indicator (dry eye) sight glass is located beyond the filter/drier to indicate the concentration of moisture in the refrigerant. If the moisture indicator indicates moisture, locate the source of the liquid immediately by performing a thorough leak check. Close the isolation valves on either side of the filter drier. Use the Schrader valve to relieve pressure in the isolated filter/drier. Replace the filter/drier and evacuate the isolated section of tubing with a vacuum pump attached to the Schrader valve.

Oil Strainers — The oil reclaim system has two strainers. One is installed in the VFD refrigerant cooling line between the cooler and condenser. The second strainer is located in the oil sump strainer housing (see Fig. 56). The oil sump strainer must

be replaced or inspected with the refrigerant charge isolated in the condenser. Inspect the oil sump strainer for obstructions or damage every time the oil is changed. The strainer threads into the oil sump strainer housing. Install a new strainer o-ring if the entire strainer does not require replacement.

VFD Refrigerant Strainer — A refrigerant strainer is located in the line that supplies refrigerant to the VFD. Three isolation valves in the refrigerant cooling lines must be closed before this strainer is changed. See Fig. 58.

Vaporizer Refrigerant Return Line Orifice — There is a metering orifice where the refrigerant return line attaches to the vaporizer (see Fig. 56). This orifice can only be inspected by cutting the vaporizer refrigerant return line near the vaporizer. This orifice should be inspected if hot condenser gas flow through the vaporizer appears to be obstructed.

Compressor Inlet Bearing Oil Orifice — The oil line leading to the compressor lubrication block is connected to the inlet bearing oil orifice. The orifice is pressed into a standard reducer/expander fitting and protected by a 50 x 50 mesh screen (see Fig. 59). Compressor oil lines and fittings between the oil filter and compressor must be capped during dis-

assembly to prevent contamination. Inspect the inlet bearing oil orifice whenever the oil line between the oil filter and compressor is disconnected.

Inspect Condenser Refrigerant Float System (Frame 3-5 Heat Exchangers) — Perform this inspection when the condenser is opened for service. See Fig. 60.

1. Transfer the refrigerant into the cooler vessel or into a pumpout storage tank.
2. Remove the float access cover.
3. Clean the chamber and valve assembly thoroughly. Be sure the valve moves freely. Ensure that all openings are free of obstructions.
4. Apply thread locking adhesive (P/N 24221 [10 ml] or 24231 [50 ml]) the $\frac{3}{8}$ -in. - 16 bolts that hold the float valve in place. See Fig. 60 for a view of the float valve design. Inspect the orientation of the float slide pin. It must be pointed toward the bubbler tube for proper operation.
5. Apply gasket sealant (P/N 19XL680-002) to both sides of new gasket when reinstalling cover.

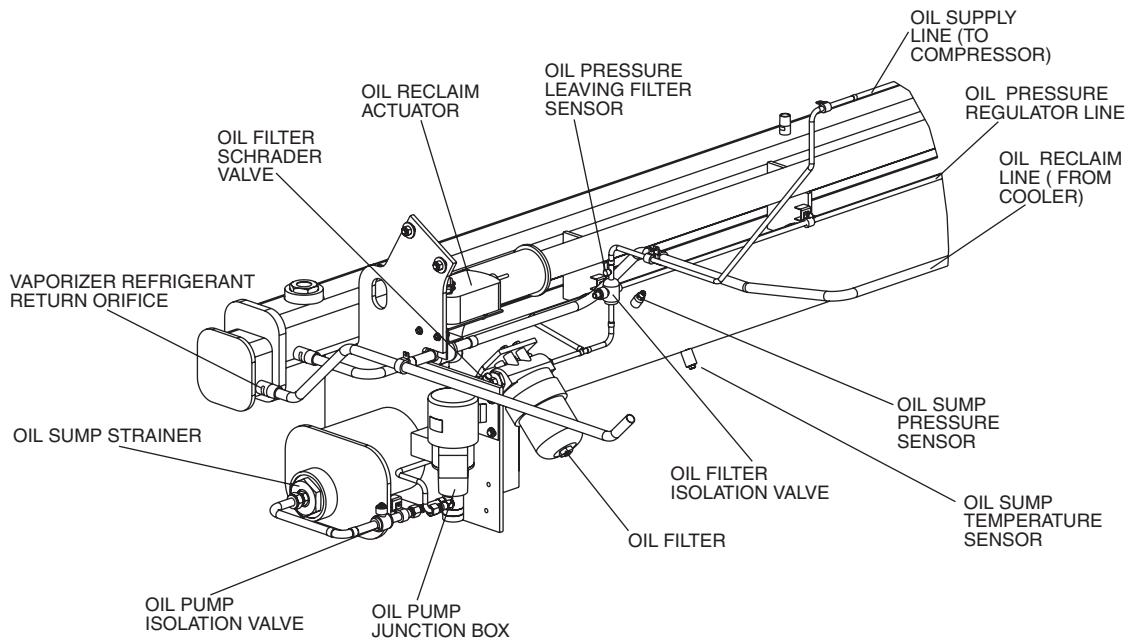

Fig. 56 — Oil Sump Strainer and Filter

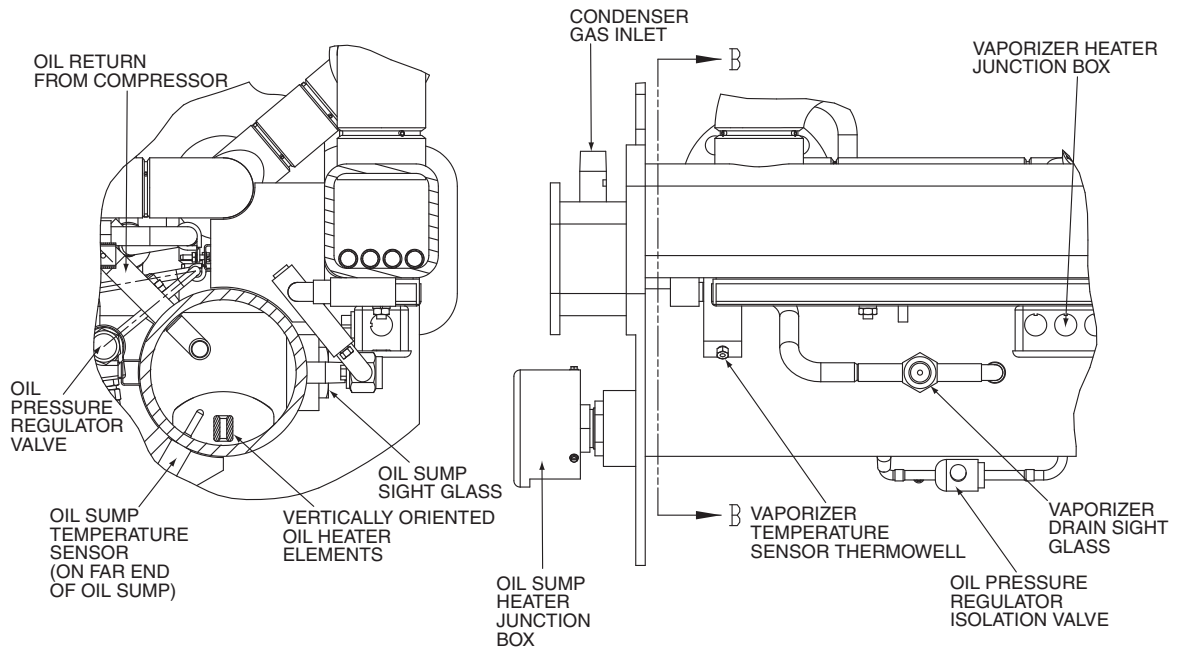

Fig. 57 — Oil Reclaim Cross Section (Q,R Compressors Shown)

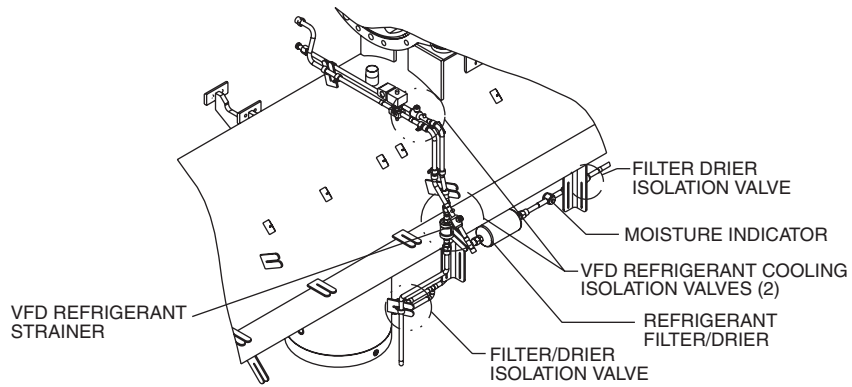

Fig. 58 — Refrigerant Filter/Drier

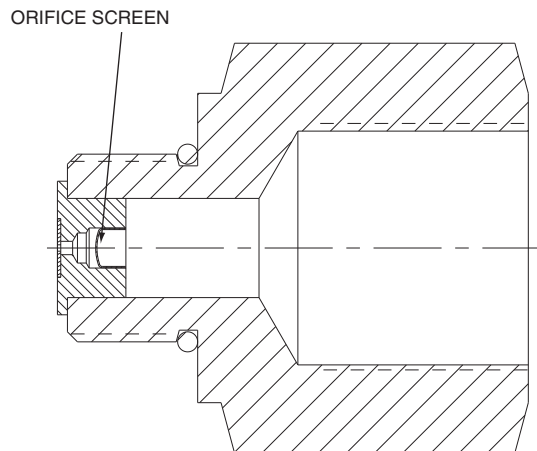
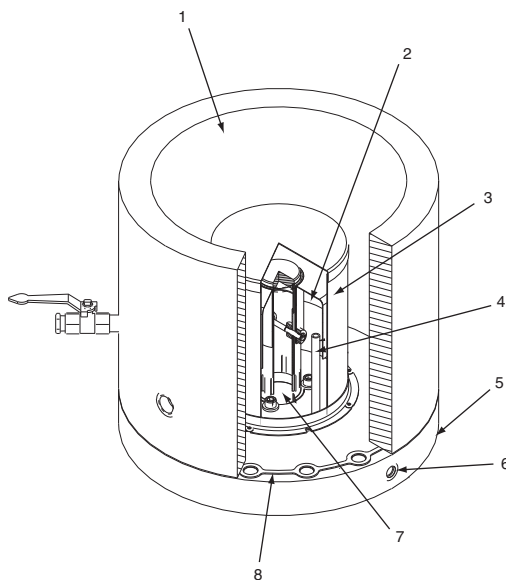

Fig. 59 — Compressor Inlet Bearing Oil Orifice



LEGEND

- 1 — Refrigerant Inlet from FLASC Chamber
- 2 — Linear Float Assembly
- 3 — Float Screen
- 4 — Bubbler Line
- 5 — Float Cover
- 6 — Bubble Line Connection
- 7 — Refrigerant Outlet to Cooler
- 8 — Gasket

Fig. 60 — 23XRV Float Valve Design (Frame 3-5 Heat Exchangers Only)

Inspect Variable Frequency Drive — Perform the following variable frequency drive inspections annually:

- Inspect the cooling fan.
- Clean the power module and cabinet (vacuum clean).
- Check and tighten electrical connections as needed.
- Perform visual inspection and capacitor test of the filter section of the VFD.
- Perform visual inspection of the inductors for overheating or other signs of deterioration. If yes, isolate and check for voltage leak.
- Test to ground (line and link reactors if applicable).
- Inspect, clean, and test harmonic filter (if applicable).
- Review and record the alarm history of the starter.
- Check drive configurations for accuracy.
- Verify that the variable frequency drive installed location is in an ambient temperature range and humidity (non-condensing) within its design values and altitude level.
- Verify that the variable speed drive throughout the year is in a clean, ventilated location.
- Verify the power supply for the VFD does not include power factor correction capacitors.
- Do not try to maintain chiller operation through an open power transfer from secondary power supplies.
- Verify that the variable speed drive is not subject to dirty electrical power, spikes, low voltage, sags, or other electrical power abnormalities.

Inspect Relief Valves and Piping — The relief valves on this chiller protect the system against the potentially dangerous effects of overpressure. To ensure against damage to the equipment and possible injury to personnel, these devices must be kept in peak operating condition. Inspect the relief valves in accordance with local codes.

At a minimum, the following maintenance is required.

1. At least once a year, disconnect the vent piping at the valve outlet and carefully inspect the valve body and mechanism for any evidence of internal corrosion or rust, dirt, scale, leakage, etc.
2. If corrosion or foreign material is found, do not attempt to repair or recondition. *Replace the valve.*

3. If the chiller is installed in a corrosive atmosphere or the relief valves are vented into a corrosive atmosphere, make valve inspections at more frequent intervals.

Compressor Bearing Maintenance — The compressor bearings are designed to last for the life of the chiller. The key to good bearing maintenance is proper lubrication. Use the proper grade of oil, maintained at recommended level, temperature, and pressure. Inspect the lubrication system regularly and thoroughly.

Excessive bearing wear can be detected through increased vibration. Carrier recommends that periodic vibration analysis be performed as part of compressor preventative maintenance program. For Optional Extended Warranty, consult the warranty's specific requirements. Contact an experienced and responsible service organization to perform vibration analysis on the compressor.

Compressor Rotor Check — Use Carrier specified oil. Excessive compressor rotor wear is shown by a lack of performance. If a lack of performance is noted, have the compressor rotors inspected by a trained service person.

The rotors can be visually inspected once every 5 to 10 years or as needed depending on chiller operating conditions.

Motor Insulation — Periodic checks of the motor insulation are recommended. (For Optional Extended Warranty, consult the warranty's specific requirements.) A 500-v megohmmeter test is recommended to assist troubleshooting if there are indications of problems including, but not limited to, moisture in the refrigerant, and chronic current imbalance or over current trips. See guidelines for megohmmeter test in the Before Initial Start-Up, Ground Fault Troubleshooting section on page 74.

CAUTION

The motor leads must be disconnected from the VFD before an insulation test is performed. The voltage generated from the test equipment can damage the solid-state VFD components.

Inspect the Heat Exchanger Tubes

COOLER — Inspect and clean the cooler tubes at the end of the first operating season. Because these tubes have internal ridges, a rotary-type tube cleaning system is necessary to fully clean the tubes. Upon inspection, the tube condition will determine the scheduled frequency for cleaning, and will indicate whether liquid treatment is adequate in the chilled liquid/brine circuit. Inspect the entering and leaving chilled liquid temperature sensors for signs of corrosion or scale. Replace the sensor if corroded or remove any scale if found.

CONDENSER — Since this liquid circuit is usually an open-type system, the tubes may be subject to contamination and scale. Clean the condenser tubes with a rotary tube cleaning system at least once per year and more often if the liquid is contaminated. Inspect the entering and leaving condenser liquid sensors for signs of corrosion or scale. Replace the sensor if corroded or remove any scale if found.

Higher than normal condenser pressures, together with the inability to reach full refrigeration load, usually indicate dirty tubes or air in the chiller. If the refrigeration log indicates a rise above normal condenser pressures, check the condenser refrigerant temperature against the leaving condenser liquid temperature. If this reading is more than what the design difference is supposed to be, then the condenser tubes may be dirty or liquid flow may be incorrect. Because HFC-134a is a high-pressure refrigerant, air usually does not enter the chiller.

During the tube cleaning process, use brushes especially designed to avoid scraping and scratching the tube wall. Contact your Carrier representative to obtain these brushes. *Do not use wire brushes.*

⚠ CAUTION

Hard scale may require chemical treatment for its prevention or removal. Consult a liquid treatment specialist for proper treatment. Failure to properly treat liquid could result in property damage or personal injury.

Water/Brine Leaks — Moisture in the refrigerant is indicated during chiller operation by the refrigerant moisture indicator on the refrigerant motor cooling line. See Fig. 2-4. Leaks should be repaired immediately.

⚠ CAUTION

The chiller must be dehydrated after repair of liquid leaks. See Chiller Dehydration section, page 71. Failure to dehydrate the chiller after repair of liquid leaks could result in equipment damage or personal injury.

Water/Brine Treatment — Untreated or improperly treated water/brine may result in corrosion, scaling, erosion, or algae. The services of a qualified water/brine treatment specialist should be obtained to develop and monitor a treatment program.

⚠ CAUTION

Water/brine must be within design flow limits, clean, and treated to ensure proper chiller performance and to reduce the potential of tubing damage due to corrosion, scaling, erosion, and algae. Carrier assumes no responsibility for chiller damage resulting from untreated or improperly treated water/brine.

Inspect the Control Center — Before working on any starter, shut off the chiller, open and tag all disconnects supplying power to the control center.

⚠ WARNING

Before working on any VFD, shut off the chiller, open and tag all disconnects supplying power to the starter. After disconnecting input power to a VFD and before touching any internal components, wait 5 minutes for the DC bus capacitors to discharge, then check the voltage with a voltmeter. Failure to observe this warning could result in severe bodily injury or death.

⚠ WARNING

The disconnect on the front of the control center does not de-energize all internal circuits. Open all internal control power and remote disconnects before servicing the starter.

⚠ CAUTION

The motor leads must be disconnected from the VFD before an insulation test is performed. The voltage generated from the tester can damage the drive components.

⚠ WARNING

Never open isolating knife switches while equipment is operating. Electrical arcing can cause serious injury.

Periodically vacuum or blow off accumulated debris on the internal parts with a high-velocity, low-pressure blower.

Power connections on newly installed control centers may relax and loosen after a month of operation. Turn power off and retighten. Recheck annually thereafter.

⚠ CAUTION

Loose power connections can cause voltage spikes, overheating, malfunctioning, or failures.

Recalibrate Pressure Transducers — Once a year, the pressure transducers should be checked against a pressure gage reading. Check all transducers (up to 9): the oil pressure delta P transducers, discharge pressure transducer, the condenser pressure transducer, the cooler pressure transducer, and the optional water side pressure transducers (consisting of 4 optional flow devices: 2 cooler, 2 condenser).

Note the evaporator and condenser pressure readings on the HEAT EX screen (*EVAPORATOR PRESSURE* and *CONDENSER PRESSURE*). Attach an accurate set of refrigeration gages to the cooler and condenser Schrader fittings. Compare the two readings. If there is a difference in readings, the transducer can be calibrated as described in the Troubleshooting Guide section. Oil differential pressure (*OIL PRESSURE DELTA P* on the COMPRESS screen) should be close to zero whenever the compressor is off. The oil pressure delta P transducers indicate the difference between oil pressure leaving filter and oil sump pressure.

Optional Pumpout System Maintenance — For pumpout unit compressor maintenance details, refer to the 19XR Positive Pressure Storage System Installation, Start-Up, and Service Instructions.

OPTIONAL PUMPOUT COMPRESSOR OIL CHARGE — Use oil conforming to Carrier specifications for reciprocating compressor usage. Oil requirements are as follows:

- HFC-134a ISO Viscosity68 or 220
 - Viscosity SSU 100 F (38 C).300 or 1005
 - Carrier Part Number . . PP23BZ-103 or PP23BZ110005
- The total oil charge is 13 oz (0.5 L).

CAUTION

Compressor oil is hygroscopic. Containers should remain tightly sealed in clean and dry environments to prevent moisture absorption from the air.

Oil should be visible in the pumpout compressor sight glass both during operation and at shutdown. Always check the oil level before operating the pumpout compressor. Before adding or changing oil, relieve the refrigerant pressure through the access valves.

Relieve refrigerant pressure and add oil to the pumpout unit as follows:

1. Refer to Fig. 53. Close service valves 2 and 4.
2. Run the pumpout compressor in Automatic mode for one minute or until the vacuum switch is satisfied and compressor shuts off.
3. **Move the pumpout selector switch to OFF.** Pumpout compressor shell should now be under vacuum.
4. Oil can be added to the shell with a hand oil pump through the access valve in the compressor base.

NOTE: Compressor access valve has a self-sealing fitting which will require a hose connection with a depressor to open.

OPTIONAL PUMPOUT SAFETY CONTROL SETTINGS (Fig. 61) — The optional pumpout system high-pressure switch should open at 185 psig (1276 kPa) and closes automatically at 140 psig (965 kPa). Check the switch setting by operating the pumpout compressor and slowly throttling the pumpout condenser liquid.

Ordering Replacement Chiller Parts — When ordering Carrier specified parts, the following information must accompany an order.

- chiller model number and serial number
- VFD model number and serial number (if applicable)
- name, quantity, and part number of the part required
- delivery address and method of shipment

TROUBLESHOOTING GUIDE

Overview — The PIC III controls have many features to help the operator and technician troubleshoot a 23XRV chiller.

- The ICVC shows the chiller’s actual operating conditions and can be viewed while the unit is running.
- The ICVC default screen freezes when an alarm occurs. The freeze enables the operator to view the chiller conditions at the time of alarm. The STATUS screens continue to show current information. Once all alarms have been cleared (by correcting the problems and pressing the **RESET** softkey), the ICVC default screen returns to normal operation.
- The CONTROL ALGORITHM STATUS screens (which include the CAPACITY, OVERRIDE, LL_MAINT, VFD HIST, CUR_ALARM, LOADSHED, WSMDEFME, and OCCDEFM screens) display information that helps to diagnose problems with chilled liquid temperature control, chilled liquid temperature control overrides, hot gas bypass, surge algorithm status, and time schedule operation. Refer to Table 18.
- The CONTROL TEST screen under the SERVICE menu facilitates the proper operation and test of temperature sensors, pressure transducers, oil reclaim output, head pressure output, oil pump, liquid pumps, tower control, and other discrete on/off outputs while the compressor is stopped. It also has the ability to lock out the compressor and turn on liquid pumps for pumpout operation. The ICVC shows the temperatures and pressures required during these operations.
- From other SERVICE tables, the operator or technician can access configured items, such as chilled liquid temperature resets, override set points, etc.

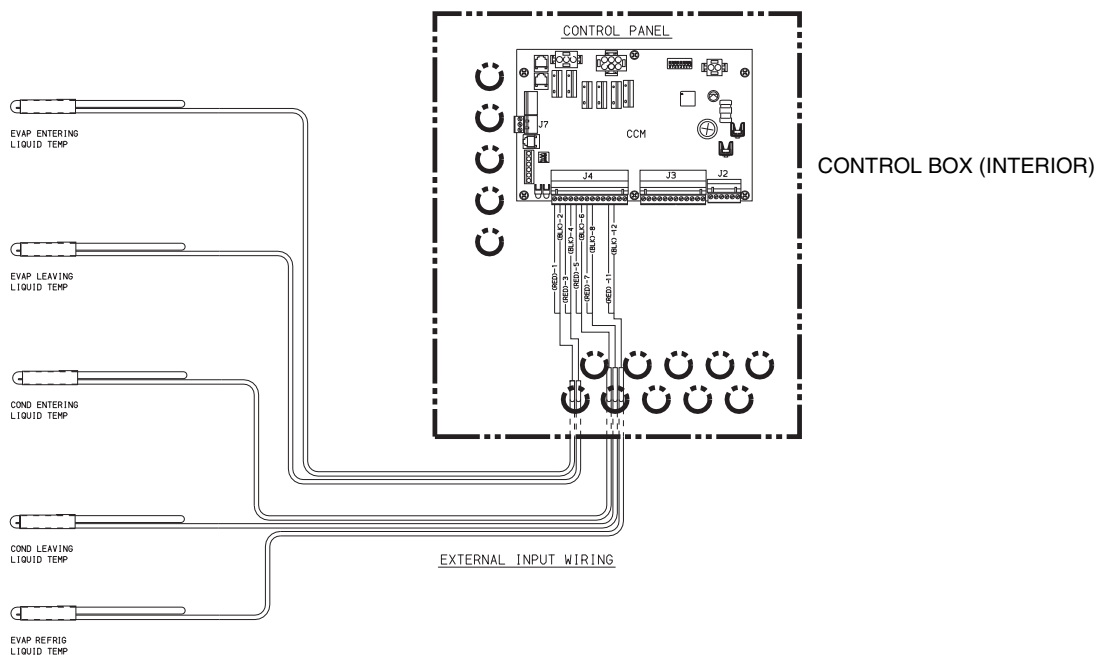

Fig. 61 — Optional Pumpout System Controls

- If an operating fault is detected, an alarm or alert message is generated and displayed on the ICVC default screen. A more detailed message — along with a diagnostic message — is also stored into the ALARM HISTORY and ALERT HISTORY tables. Refer to Tables 19 and 20.
- Review the ALERT HISTORY table to view other less critical events and abnormal conditions which may have occurred. Compare timing of relevant alerts and alarms.

Table 18 — Control Algorithm Maintenance Screens

SCREEN	TITLE	DESCRIPTION
CAPACITY	Capacity Control	This table shows all values used to calculate the chilled liquid control point.
OVERRIDE	Override Status	Details of all chilled liquid and VFD control override values.
LL_MAINT	LEAD/LAG Status	Indicates LEAD/LAG operation status.
VFD_HIST	VFD Alarm History	Displays VFD values at last fault.
LOADSHED	Loadshed Status	Displays Loadshed (Demand Limit) status.
CUR_ALARM	Current Alarm Status	Displays current chiller alarms.
WSMDEFME	Liquid System Manager Status	The liquid system manager is a CCN module that can turn on the chiller and change the chilled liquid control point. This screen indicates the status of this system.
OCCDEFM	Time Schedules Status	The Local and CCN occupied schedules are displayed here to help the operator quickly determine whether the schedule is in the "occupied" mode or not.
HEAT_EX*	HGBP Status	The hot gas bypass control algorithm status is viewed from this screen. All values related to this control are displayed.

*The HEAT_EX screen is under the STATUS menu.

Checking Display Messages — The first area to check when troubleshooting the 23XRV chiller is the ICVC display. If the alarm light is flashing, check the primary and secondary message lines on the ICVC default screen (Fig. 24). These messages will indicate where the fault is occurring. These messages contain the alarm message with a specified code. This code or state appears with each alarm and alert message. The ALARM and ALERT HISTORY tables on the ICVC SERVICE menu also contain a message to further expand on the fault condition. Note that the date format in these tables is MM/DD/YY. For a complete list of possible alarm messages, see Table 19. If the alarm light starts to flash while accessing a menu screen, press the **EXIT** softkey to return to the default screen to read the alarm message. The STATUS screen can also be accessed to determine where an alarm exists. A "C" to the right of a parameters value means there is a communications fault on that channel.

Checking Temperature Sensors — Except for the motor temperature sensors, all temperature sensors are installed in thermowells. This eliminates the need to drain the refrigerant, oil, or liquid from the chiller to replace the sensor. All temperature sensors are thermistor-type sensors. This means that the resistance of the sensor varies with temperature. All sensors have the same resistance characteristics.

RESISTANCE CHECK — Turn off the control power and, from the module, disconnect the terminal plug of the sensor in question. With a digital ohmmeter, measure sensor resistance between receptacles as designated by the wiring diagram.

The resistance and corresponding temperature are listed in Table 21 or 22. Check the resistance of both wires to ground. This resistance should be infinite.

VOLTAGE DROP — The voltage drop across any energized sensor can be measured with a digital voltmeter while the control is energized. Table 21 or 22 lists the relationship between temperature and sensor voltage drop (volts dc measured across the energized sensor). Exercise care when measuring voltage to prevent damage to the sensor leads, connector plugs, and modules. Sensors should also be checked at the sensor plugs. Check the sensor wire at the sensor for 5 vdc if the control is powered on.

CHECK SENSOR ACCURACY — Place the sensor in a medium of known temperature and compare that temperature to the measured reading. The thermometer used to determine the temperature of the medium should be of laboratory quality with 0.5° F (.25° C) graduations. The sensor in question should be accurate to within 2° F (1.2° C).

See Fig. 5-7 for sensor locations. Temperature sensors are inserted into a thermowell in the refrigerant or liquid circuits. When installing a new sensor thermowell, apply a pipe sealant or thread sealant (RCD part number 56507) to the thermowell threads. Coat the temperature sensors with thermally conductive grease (RCD Part Number PP8024) before inserting into the thermowell.

DUAL MOTOR TEMPERATURE SENSORS — For servicing convenience, there are 2 sensors on the motor temperature sensor. If one of the sensors is damaged, the other can be used by simply moving a wire. The number 2 terminal in the sensor terminal box is the common line. To use the second sensor, move the wire from the number 1 position to the number 3 position.

Checking Pressure Transducers — There are as many as 9 pressure transducers on 23XRV chillers. They determine *EVAPORATOR PRESSURE*, *CONDENSER PRESSURE*, oil pressure leaving filter, oil sump pressure, *DISCHARGE PRESSURE*, and optional *CHILLED LIQUID DELTA P* and *CONDENSER LIQUID DELTA P*. The *EVAPORATOR PRESSURE* and *CONDENSER PRESSURE* transducers are also used by the PIC III to determine the refrigerant temperatures. The *OIL PRESSURE DELTA P* (oil pressure leaving filter – oil sump pressure) is calculated by the CCM.

All pressure transducers should be calibrated prior to initial start-up. At high altitude locations, it is necessary to calibrate the transducers to ensure the proper refrigerant temperature/pressure relationship. Each transducer is supplied with 5 vdc power from the CCM. If the power supply fails, a transducer voltage reference alarm (239) is declared. If the transducer reading is suspected of being faulty, check the *TRANSDUCER VOLTAGE REF* supply voltage. It should be 5 vdc ± .5 v displayed in *CONTROL TEST* under *PRESSURE TRANSDUCERS*. If the *TRANSDUCER VOLTAGE REF* is correct, the transducer should be recalibrated or replaced.

Also check that inputs on CCM J5-1 through J5-6 have not been grounded and are not receiving anything other than a 4 to 20 mA signal.

COOLER CONDENSER PRESSURE TRANSDUCER AND OPTIONAL WATER SIDE PRESSURE TRANSDUCER CALIBRATION — Calibration can be checked by comparing the pressure readings from the transducer to an accurate refrigeration gage reading. These readings can be viewed or calibrated from the HEAT_EX screen on the ICVC. The transducer can be checked and calibrated at 2 pressure points. These calibration points are 0 psig (0 kPa) and between 25 and 250 psig (173 and 1724 kPa). To calibrate these transducers:

1. Shut down the compressor, cooler, and condenser pumps.

NOTE: There should be no flow through the heat exchangers.

2. Disconnect the transducer in question from its Schrader fitting for cooler or condenser transducer calibration. For oil pressure delta P, the optional cooler and condenser liquid delta P, or flow device calibration, leave the transducer in place.

NOTE: If the cooler or condenser vessels are at 0 psig (0 kPa) or are open to atmospheric pressure, the transducers can be calibrated for zero without removing the transducer from the vessel.

3. Access the HEAT_EX (or the ECON_EXV for *ECONOMIZER PRESSURE* for P compressor with economizer option) screen and view the particular transducer reading (the *EVAPORATOR PRESSURE* or *CONDENSER PRESSURE* parameter on the HEAT_EX screen). To calibrate oil pressure or water side pressure transducer, view the particular reading (*CHILLED LIQUID DELTA P* and *CONDENSER LIQUID DELTA P* on the HEAT_EX screen, and *OIL PRESSURE DELTA P* on the COMPRESS screen). It should read 0 psi (0 kPa). If the reading is not 0 psi (0 kPa), but within ± 5 psi (35 kPa), the value may be set to zero by pressing the **SELECT** softkey while the appropriate transducer parameter is highlighted on the ICVC screen. Then press the **ENTER** softkey. The value will now go to zero. No high end calibration is necessary for *OIL PRESSURE DELTA P*, optional *CHILLED LIQUID DELTA P* or *CONDENSER LIQUID DELTA P* or for flow devices.

If the transducer value is not within the calibration range, the transducer returns to the original reading. If the pressure is within the allowed range (noted above), check the voltage ratio of the transducer. To obtain the voltage ratio, divide the voltage (dc) input from the transducer (white wire to black wire) by the *TRANSDUCER VOLTAGE REF* supply voltage signal (displayed in CONTROL TEST menu in the PRESSURE TRANSDUCERS screen). The *TRANSDUCER VOLTAGE REF* can be measured across the positive (+ red) and negative (- black) leads of the transducer. For example, the condenser transducer reference voltage is measured at CCM terminals J2-4 (black) and J2-6 (red). The condenser transducer input voltage is measured at CCM terminals J2-4 (black) and J2-5 (clear or white). The input voltage to reference voltage ratio must be between 0.80 and 0.11 for the software to allow calibration. Pressurize the transducer until the ratio is within range, then attempt calibration again.

4. A high pressure point can also be calibrated between 25 and 250 psig (172.4 and 1723.7 kPa) by attaching a regulated 250 psig (1724 kPa) pressure (usually from a nitrogen cylinder). The high pressure point can be calibrated by accessing the appropriate transducer parameter on the HEAT_EX screen, highlighting the parameter, pressing the **SELECT** softkey, and then using the **INCREASE** or **DECREASE** softkeys to adjust the value to the exact pressure on the refrigerant gage. Press the **ENTER** softkey to finish the calibration. Pressures at high altitude locations must be compensated for, so the chiller temperature/pressure relationship is correct.

The PIC III controls do not allow calibration if the transducer is too far out of calibration. In this case, a new transducer must be installed and re-calibrated. If calibration problems are encountered on the *OIL PRESSURE DELTA P* channel, sometimes swapping the oil pressure leaving filter and the oil sump pressure transducer locations will offset an adverse transducer tolerance stack up and allow the calibration to proceed.

TRANSDUCER REPLACEMENT — Since the pressure transducers are mounted on Schrader-type fittings, there is no need to remove refrigerant from the vessel when replacing the transducers. Disconnect the transducer wiring by pulling up on the locking tab while pulling up on the weather-tight connecting plug from the end of the transducer. *Do not pull on the transducer wires.* Unscrew the transducer from the Schrader fitting. When installing a new transducer, do not use pipe sealer (which can plug the sensor). Put the plug connector back on the sensor and snap into place. Check for refrigerant leaks.

CAUTION

Be sure to use a back-up wrench on the Schrader fitting whenever removing a transducer, since the Schrader fitting may back out with the transducer, causing a large leak and possible injury to personnel.

Control Algorithms Checkout Procedure —

One of the tables on the ICVC SERVICE menu is CONTROL ALGORITHM STATUS. The maintenance screens may be viewed from the CONTROL ALGORITHM STATUS table to see how a particular control algorithm is operating.

These maintenance screens are very useful in helping to determine how the control temperature is calculated and for observing the reactions from load changes, control point overrides, hot gas bypass, surge prevention, etc. See Table 18.

Control Test — The Control Test feature can check all the thermistor temperature sensors, pressure transducers, pumps and their associated flow devices, the oil reclaim output, the head pressure output, and other control outputs such as tower fans, VFD cooling solenoid (if applicable), shut trip relay, oil heaters, alarm relay, and hot gas bypass. The tests can help to determine whether a switch is defective or if a pump relay is not operating, as well as other useful troubleshooting issues. During pumpdown operations, the pumps are energized to prevent freeze-up and the vessel pressures and temperatures are displayed. The Pumpdown/Lockout feature prevents compressor start-up when there is no refrigerant in the chiller or if the vessels are isolated. The Terminate Lockout feature ends the Pumpdown/Lockout after the pumpdown procedure is reversed and refrigerant is added.

LEGEND FOR TABLE 19

- CCM** — Chiller Control Module
- CCN** — Carrier Comfort Network®
- ICVC** — International Chiller Visual Controller
- CHL** — Chilled Liquid
- PIC III** — Product Integrated Control III
- VFD** — Variable Frequency Drive
- WSM** — Water System Manager

Table 19 — ICVC Primary and Secondary Messages and Custom Alarm/Alert Messages with Troubleshooting Guides

A. MANUAL STOP

PRIMARY MESSAGE	SECONDARY MESSAGE	PROBABLE CAUSE/REMEDY
MANUALLY STOPPED — PRESS	CCN OR LOCAL TO START	PIC III in OFF mode, press CCN or LOCAL softkey to start unit.
TERMINATE PUMPDOWN MODE	TO SELECT CCN OR LOCAL	Enter the CONTROL TEST table and select TERMINATE LOCKOUT to unlock compressor.
SHUTDOWN IN PROGRESS	COMPRESSOR UNLOADING	Chiller unloading before shutdown due to soft/stop feature.
SHUTDOWN IN PROGRESS	COMPRESSOR DEENERGIZED	Chiller compressor is being commanded to stop. Liquid pumps are deenergized within one minute.
ICE BUILD	OPERATION COMPLETE	Chiller shutdown from Ice Build operation.
SHUTDOWN IN PROGRESS	RECYCLE RESTART PENDING	Chiller is shutting down in recycle mode

B. READY TO START

PRIMARY MESSAGE	SECONDARY MESSAGE	PROBABLE CAUSE/REMEDY
READY TO START IN XX MIN	UNOCCUPIED MODE	Time schedule for PIC III is unoccupied. Chillers will start only when occupied.
READY TO START IN XX MIN	REMOTE CONTACTS OPEN	Remote contacts are open. Close contacts on Terminal Block TB1 to start.
READY TO START IN XX MIN	STOP COMMAND IN EFFECT	Chiller START/STOP on MAINSTAT manually forced to stop. Release force or send START force to start.
READY TO START IN XX MIN	OCCUPIED MODE	Chiller timer counting down. Unit ready to start.
READY TO START IN XX MIN	REMOTE CONTACTS CLOSED	Chiller timer counting down. Unit ready to start. Remote contact enabled and closed. The chiller will stop when the contacts are opened.
READY TO START IN XX MIN	START COMMAND IN EFFECT	Chiller START/STOP on MAINSTAT manually forced to start. Release force to start under normal control.
READY TO START IN XX MIN	RECYCLE RESTART PENDING	Chiller in recycle mode.
READY TO START	UNOCCUPIED MODE	Time schedule for PIC III is unoccupied. Chiller will start when occupied. Make sure the time and date are correct. Change values in TIME AND DATE screen.
READY TO START	REMOTE CONTACTS OPEN	Remote contacts have stopped the chiller. Close contact on Terminal Block TB1 to start.
READY TO START	STOP COMMAND IN EFFECT	Chiller START/STOP on MAINSTAT manually forced to stop. Release point to start.
READY TO START	OCCUPIED MODE	Chiller timer count down complete, unit start will commence.
READY TO START	REMOTE CONTACTS CLOSED	Chiller timer count down complete. Unit ready for start.
READY TO START	START COMMAND IN EFFECT	Chiller START/STOP on MAINSTAT has been manually forced to start. Chiller will start regardless of time schedule or remote contact status.
STARTUP INHIBITED	LOADSHED IN EFFECT	CCN loadshed module commanding chiller to stop.

C. IN RECYCLE SHUTDOWN

PRIMARY MESSAGE	SECONDARY MESSAGE	PROBABLE CAUSE/REMEDY
RECYCLE RESTART PENDING	OCCUPIED MODE	Unit in recycle mode, chilled liquid temperature is not sufficiently above set point to start.
RECYCLE RESTART PENDING	REMOTE CONTACTS CLOSED	Unit in recycle mode, chilled liquid temperature is not sufficiently above set point to start.
RECYCLE RESTART PENDING	START COMMAND IN EFFECT	Chiller START/STOP on MAINSTAT manually forced to start, chilled liquid temperature is not sufficiently above set point to start.
RECYCLE RESTART PENDING	ICE BUILD MODE	Chiller in ICE BUILD mode. Chilled liquid temperature is satisfied for ICE BUILD conditions.

Table 19 — ICVC Primary and Secondary Messages and Custom Alarm/Alert Messages with Troubleshooting Guides (cont)

D. PRE-START ALERTS: These alerts are only declared after a start command is issued and only delay start-up. When alert is corrected, the start-up will continue. No reset is necessary.

STATE	PRIMARY MESSAGE	SECONDARY MESSAGE	ALARM MESSAGE PRIMARY CAUSE	ADDITIONAL CAUSE/REMEDY
100	PRESTART ALERT	STARTS LIMIT EXCEEDED	100->Excessive compressor starts (8 in 12 hours)	Depress the RESET softkey if additional start is required. Reassess start-up requirements.
101	PRESTART ALERT	HIGH RECTIFIER TEMP	101->Rectifier Temperature [VALUE] exceeded limit of [LIMIT]*.	Check RECTIFIER TEMPERATURE in POWER screen. Check VFD refrigerant isolation valves. Check VFD power module cooling fan. Check RECTIFIER TEMP OVERRIDE in SETUP1 screen. See Table 5.
102	PRESTART ALERT	HIGH MOTOR TEMPERATURE	102->Comp Motor Winding Temp [VALUE] exceeded limit of [LIMIT]*.	Check COMP MOTOR WINDING TEMP in COMPRESS screen. Check motor temperature sensors for wiring and accuracy. Check motor cooling line for proper operation, or restrictions. Check for excessive starts within a short time span. Check MOTOR TEMP OVERRIDE in SETUP1 screen. See Table 5.
103	PRESTART ALERT	HIGH DISCHARGE TEMP	103->Comp Discharge Temp [VALUE] exceeded limit of [LIMIT]*.	Check COMP DISCHARGE TEMP in COMPRESS screen. Allow Compressor Discharge Sensor to cool. Check for Compressor Discharge sensor wiring and accuracy. Check for excessive starts. Check COMP DISCHARGE ALERT in SETUP1 screen. See Table 5.
104	PRESTART ALERT	LOW REFRIGERANT TEMP	104->Evaporator Refrig Temp [VALUE] exceeded limit of [LIMIT]*.	Check EVAPORATOR PRESSURE in HEATEX screen. Check Evaporator Pressure transducer wiring and accuracy. Check for low chilled fluid supply temperatures. Check refrigerant charge. Check REFRIG OVERRIDE DELTA T in SETUP1 screen. See Table 5.
105	PRESTART ALERT	LOW OIL TEMPERATURE	105->Oil Sump Temp [VALUE] exceeded limit of [LIMIT]*.	Check OIL SUMP TEMP in ICVC default screen. Check Oil Sump Temperature sensor wiring and accuracy. Check 1C oil heater contactor/relay and power. Check oil level and oil pump operation. Confirm that oil reclaim valve is closed when chiller is not running. See Table 5. Check oil heater element for carbon build-up.
106	PRESTART ALERT	HIGH CONDENSER PRESSURE	106->Condenser Pressure [VALUE] exceeded limit of [LIMIT]*.	Check CONDENSER PRESSURE in HEATEX screen. Check Condenser Pressure transducer wiring and accuracy. Check for high condenser liquid temperatures. Check COND PRESS OVERRIDE in SETUP1 screen. See Table 5.
107	PRESTART ALERT	LOW LINE VOLTAGE	107->Percent Line Voltage [VALUE] exceeded limit of [LIMIT]*.	Check Line Voltage in POWER screen. Check voltage supply. Check voltage transformers. Consult power utility if voltage is low. Check FU1, FU2, and FU3 in the VFD. Check connectors on VFD Line Synch Printed Circuit Board. See Table 5.
108	PRESTART ALERT	HIGH LINE VOLTAGE	108->Percent Line Voltage [VALUE] exceeded limit of [LIMIT]*.	Check Line Voltage in POWER screen. Check voltage supply. Check power transformers. Consult power utility if voltage is high. See Table 5.
109	PRESTART ALERT	HIGH INVERTER TEMP	109->Inverter Temperature [VALUE] exceeded limit of [LIMIT]*.	Check INVERTER TEMPERATURE in POWER screen. Check VFD refrigerant isolation valves. Check VFD power module cooling fan. Check INVERTER TEMP OVERRIDE in SETUP1 screen. See Table 5.

*[LIMIT] is shown on the ICVC as temperature, pressure, voltage, etc., predefined or selected by the operator as an override or an alert. [VALUE] is the actual pressure, temperature, voltage, etc., at which the control tripped.

Table 19 — ICVC Primary and Secondary Messages and Custom Alarm/Alert Messages with Troubleshooting Guides (cont)

E. START-UP IN PROGRESS

PRIMARY MESSAGE	SECONDARY MESSAGE	CAUSE/REMEDY
STARTUP IN PROGRESS	OCCUPIED MODE	Chiller is starting. Time schedule is occupied (OCCUPIED? = YES).
STARTUP IN PROGRESS	REMOTE CONTACT CLOSED	Chiller is starting. REMOTE CONTACTS OPTION is set to ENABLE. Remote contacts input on terminal block TB1 terminals 23 and 24 are closed.
STARTUP IN PROGRESS	START COMMAND IN EFFECT	Chiller is starting. CHILLER START/STOP in MAINSTAT manually forced to START.
AUTORESTART IN PROGRESS	OCCUPIED MODE	Chiller is starting after power failure. Time schedule is occupied (OCCUPIED? = YES).
AUTORESTART IN PROGRESS	REMOTE CONTACT CLOSED	Chiller is starting after power failure. REMOTE CONTACTS OPTION is set to ENABLE. Remote contacts input on terminal block TB1 terminals 23 and 24 are closed.
AUTORESTART IN PROGRESS	START COMMAND IN EFFECT	Chiller is starting after power failure. CHILLER START/STOP on MAINSTAT manually forced to START.

F. NORMAL RUN

PRIMARY MESSAGE	SECONDARY MESSAGE	CAUSE/REMEDY
RUNNING — RESET ACTIVE	BY 4-20 mA SIGNAL	Auto chilled liquid reset active based on external input. ENABLE RESET TYPE =1. A non-zero temperature reset based on a 4-20 mA signal on CCM J5-3 and J5-4 is being added to the SETPOINT to determine the CONTROL POINT. See TEMP_CTL screen.
RUNNING — RESET ACTIVE	REMOTE TEMP SENSOR	Auto chilled liquid reset active based on external input. ENABLE RESET TYPE =2. A non-zero temperature reset based on the remote sensor signal on CCM J4-13 and J4-14 is being added to the SETPOINT to determine the CONTROL POINT. See TEMP_CTL screen.
RUNNING — RESET ACTIVE	CHL TEMP DIFFERENCE	Auto chilled liquid reset active based on cooler Delta T. ENABLE RESET TYPE =3. A non-zero temperature reset based on the difference between the ENTERING CHILLED LIQUID and LEAVING CHILLED LIQUID is being added to the SETPOINT to determine the CONTROL POINT. See TEMP_CTL screen.
RUNNING — TEMP CONTROL	LEAVING CHILLED LIQUID	Default method of temperature control. ECL CONTROL OPTION = DSABLE. Chiller capacity is being controlled so the LEAVING CHILLED LIQUID temperature is being maintained within 1/2 of the CHILLED LIQUID DEADBAND on either side of the CONTROL POINT. See TEMP_CTL screen.
RUNNING — TEMP CONTROL	ENTERING CHILLED LIQUID	Entering Chilled Liquid (ECL) control enabled. ECL CONTROL OPTION = ENABLE. Chiller capacity is being controlled so the ENTERING CHILLED LIQUID temperature is being maintained within 1/2 of the CHILLED LIQUID DEADBAND on either side of the CONTROL POINT. See TEMP_CTL screen.
RUNNING — TEMP CONTROL	TEMPERATURE RAMP LOADING	Ramp Loading based on LEAVING CHILLED LIQUID or ENTERING CHILLED LIQUID is in effect. PULLDOWN RAMP TYPE = 0. Capacity inhibit is in effect because LEAVING CHILLED LIQUID or ENTERING CHILLED LIQUID has fallen below the ramping temperature pulldown setpoint. See RAMP_DEM screen.
RUNNING — DEMAND LIMITED	BY DEMAND RAMP LOADING	Ramp Loading based on PERCENT LINE CURRENT or PERCENT LINE KILOWATTS is in effect. PULLDOWN RAMP TYPE = 0. Capacity inhibit is in effect because PERCENT LINE CURRENT or PERCENT LINE KILOWATTS has exceeded the ramping active demand limit. See RAMP_DEM screen.
RUNNING — DEMAND LIMITED	BY LOCAL DEMAND SETPOINT	Actual demand has exceeded ACTIVE DEMAND LIMIT. 20mA DEMAND LIMIT OPTION is DISABLED. ACTIVE DEMAND LIMIT is set equal to BASED DEMAND LIMIT. PERCENT LINE CURRENT or PERCENT LINE KILOWATTS is greater than ACTIVE DEMAND LIMIT.
RUNNING — DEMAND LIMITED	BY 4-20 mA SIGNAL	Actual demand has exceeded ACTIVE DEMAND LIMIT. 20mA DEMAND LIMIT OPTION is ENABLED. ACTIVE DEMAND LIMIT is adjusted based on 4-20 mA signal received on CCM J5-1 and J5-2. PERCENT LINE CURRENT or PERCENT LINE KILOWATTS is greater than ACTIVE DEMAND LIMIT.
RUNNING — DEMAND LIMITED	BY CCN SIGNAL	Actual demand has exceeded ACTIVE DEMAND LIMIT. Chiller CONTROL MODE = CCN. Value of ACTIVE DEMAND LIMIT is being forced by a CCN device. PERCENT LINE CURRENT or PERCENT LINE KILOWATTS is greater than ACTIVE DEMAND LIMIT.
RUNNING — DEMAND LIMITED	BY LOADSHED/REDLINE	Actual demand has exceeded ACTIVE DEMAND LIMIT. Chiller CONTROL MODE = CCN. Value of ACTIVE DEMAND LIMIT was set equal to PERCENT LINE CURRENT or PERCENT LINE KILOWATTS at the time a Redline command was received by the loadshed POC (Program Outboard Control). PERCENT LINE CURRENT or PERCENT LINE KILOWATTS is greater than ACTIVE DEMAND LIMIT. See LOADSHED screen.
RUNNING — TEMP CONTROL	HOT GAS BYPASS	HOT GAS BYPASS OPTION is set to ENABLE and HOT GAS BYPASS RELAY is ON.
RUNNING — DEMAND LIMITED	BY LOCAL SIGNAL	ACTIVE DEMAND LIMIT has been manually forced on MAINSTAT screen.
RUNNING — TEMP CONTROL	ICE BUILD MODE	ICE BUILD OPTION is set to ENABLE and chiller is running under Ice Build temperature control.
RUNNING — DEMAND LIMITED	MOTOR LOAD CURRENT	Actual demand has exceeded ACTIVE DEMAND LIMIT. Capacity inhibit is active because PERCENT LOAD CURRENT is greater than 100%.
RUNNING — DEMAND LIMITED	VFD LINE CURRENT	Actual demand has exceeded ACTIVE DEMAND LIMIT. Capacity inhibit is active because PERCENT LINE CURRENT exceeds 100%.

Table 19 — ICVC Primary and Secondary Messages and Custom Alarm/Alert Messages with Troubleshooting Guides (cont)

G. NORMAL RUN WITH OVERRIDES

STATE	PRIMARY MESSAGE	SECONDARY MESSAGE	ALARM MESSAGE PRIMARY CAUSE	ADDITIONAL CAUSE/REMEDY
120	RUN CAPACITY LIMITED	HIGH CONDENSER PRESSURE	120->Condenser Pressure [VALUE] exceeded limit of [LIMIT]*.	Check for high condenser liquid temperatures. Check COND PRESS OVERRIDE setting in SETUP1.
121	RUN CAPACITY LIMITED	HIGH MOTOR TEMPERATURE	121->Comp Motor Winding Temp [VALUE] exceeded limit of [LIMIT]*.	Check motor cooling lines. Check for closed valves. Check COMP MOTOR TEMP OVERRIDE setting in SETUP1.
122	RUN CAPACITY LIMITED	LOW EVAP REFRIG TEMP	122->Evaporator Refrig Temp [VALUE] exceeded limit of [LIMIT]*.	Check REFRIG OVERRIDE DELTA T setting in SETUP1 screen. Check refrigerant charge. Check for low entering cooler temperatures.
123	RUN CAPACITY LIMITED	HIGH RECTIFIER TEMP	123->Rectifier Temperature [VALUE] exceeded limit of [LIMIT]*	Check VFD refrigerant isolation valves. Check VFD refrigerant cooling solenoid valve. Check RECTIFIER TEMP OVERRIDE in SETUP1 screen.
124	RUN CAPACITY LIMITED	MANUAL SPEED CONTROL		TARGET VFD SPEED in COMPRESS screen is forced to a fixed value.
125	RUN CAPACITY LIMITED	HIGH INVERTER TEMP	125->Inverter Temperature [VALUE] exceeded limit of [LIMIT]*	Check VFD refrigerant isolation valves. Check VFD refrigerant cooling solenoid valve. Check INVERTER TEMP OVERRIDE in SETUP1 screen.
126	RUN CAPACITY OVERRIDE	COMP MIN SPEED IN EFFECT		TARGET VFD SPEED is clamped to COMP MINIMUM SPEED due to oil viscosity.
127	RUN CAPACITY OVERRIDE	COMP MAX SPEED LIMITED		TARGET VFD SPEED is clamped to VFD MAXIMUM SPEED. Check VFD MAXIMUM SPEED in SETUP2 screen.

[LIMIT] is shown on the ICVC as the temperature, pressure, voltage, etc., set point predefined or selected by the operator as an override, alert, or alarm condition. [VALUE] is the actual pressure, temperature, voltage, etc., at which the control has recorded at the time of the fault condition.

H. OUT-OF-RANGE SENSOR ALARMS

STATE	PRIMARY MESSAGE	SECONDARY MESSAGE	ALARM MESSAGE PRIMARY CAUSE	ADDITIONAL CAUSE/REMEDY
260	SENSOR FAULT	LEAVING CHILLED LIQUID	260->Sensor Fault: Check Leaving Chilled Liquid Sensor	Check sensor resistance or voltage drop against Table 21 or 22. Check for proper wiring between Leaving Chilled Liquid Temperature sensor and CCM. Check for grounded sensor lead. See Table 5.
261	SENSOR FAULT	ENTERING CHILLED LIQUID	261->Sensor Fault: Check Entering Chilled Liquid Sensor	Check sensor resistance or voltage drop against Table 21 or 22. Check for proper wiring between Entering Chilled Liquid Sensor and CCM. Check for grounded sensor lead. See Table 5.
262	SENSOR FAULT	CONDENSER PRESSURE	262->Sensor Fault: Check Condenser Pressure Sensor	Confirm that 5V Reference voltage is available on CCM. Check sensor voltage drop. Check for proper wiring between Condenser Pressure Sensor and CCM. Check for grounded sensor lead. Check for condensation inside of pressure sensor connector. See Table 5.
263	SENSOR FAULT	EVAPORATOR PRESSURE	263->Sensor Fault: Check Evaporator Pressure Sensor	Confirm that 5V Reference voltage is available on CCM. Check sensor voltage drop. Check for proper wiring between Evaporator Pressure Sensor and CCM. Check for grounded sensor lead. Check for condensation inside of pressure sensor connector. See Table 5.
264	SENSOR FAULT	OIL PRESS SENSOR FAULT	264->Sensor Fault: Check Oil Pressure Delta P Sensor	Confirm that 5V Reference voltage is available on CCM. Check sensor voltage drops. Check for proper wiring between Oil Sump Pressure and Oil Pressure Leaving Filter Sensors and CCM. Check for grounded sensor lead. Check for condensation inside of pressure sensor connectors. See Table 5.

Table 19 — ICVC Primary and Secondary Messages and Custom Alarm/Alert Messages with Troubleshooting Guides (cont)

H. OUT-OF-RANGE SENSOR ALARMS (cont)

STATE	PRIMARY MESSAGE	SECONDARY MESSAGE	ALARM MESSAGE PRIMARY CAUSE	ADDITIONAL CAUSE/REMEDY
266	SENSOR FAULT	OIL SUMP TEMP	266->Sensor Fault: Check Oil Sump Temp Sensor	Check sensor resistance or voltage drop against Table 21 or 22. Check for proper wiring between Oil Sump Pressure Sensor and CCM. Check for grounded sensor lead. See Table 5.
267	SENSOR FAULT	COMP DISCHARGE TEMP	267->Sensor Fault: Check Comp Discharge Temp Sensor	Check sensor resistance or voltage drop against Table 21 or 22. Check for proper wiring between sensor and CCM. Check for grounded sensor lead. See Table 5.
268	SENSOR FAULT	CHILLED LIQUID FLOW	268->Sensor Fault: Check Chilled Liquid Delta P Sensor	Check for 4300 ohm load resistor on J3-14 and J3-15. Check for jumper between J3-17 and J3-18. Confirm that 5V Reference voltage is available on CCM. See Table 5. Check sensor voltage drops. Check for proper wiring between optional Entering Chilled Liquid Pressure and Leaving Chilled Liquid Pressure Sensors and CCM. Check for grounded sensor lead. Check for condensation inside of optional pressure sensor connectors. J3-17 to J3-18 jumper must be replaced with a 4300 ohm resistor if optional flow switch is installed, see Certified Prints.
269	SENSOR FAULT	COND LIQUID FLOW ECONOMIZER PRES-SURE (P compressor)	269->Sensor Fault: Check Cond Liquid Delta P Sensor. 269->Sensor Fault: Check Economizer Pressure Sensor.	Check for 4300 ohm load resistor on J3-20 and J3-21. Check for jumper between J3-23 and J3-24. Confirm that 5V Reference voltage is available on CCM. See Table 5. Check sensor voltage drops. Check for proper wiring between optional Entering Condenser Liquid Pressure and Leaving Condenser Liquid Pressure Sensors and CCM. Check for grounded sensor lead. Check for condensation inside of optional pressure sensor connectors. J3-17 to J3-18 jumper must be replaced with a 4300 ohm resistor if optional flow switch is installed, see Certified Prints.
270	SENSOR FAULT	EVAP REFRIG LIQUID TEMP	270->Sensor Fault: Check Evap Refrig Liquid Temp Sensor	Check sensor resistance or voltage drop against Table 21 or 22. Check for proper wiring between Evaporator Refrigerant Liquid Temperature Sensor and CCM. Check for grounded sensor lead. See Table 5.
271	SENSOR FAULT	VAPORIZER TEMP	271->Sensor Fault: Check Vaporizer Temp Sensor	Check sensor resistance or voltage drop against Table 21 or 22. Check for proper wiring between Vaporizer Temperature Sensor and CCM. Check for grounded sensor lead. See Table 5.
272	SENSOR FAULT	DISCHARGE PRESSURE	272->Sensor Fault: Check Discharge Pressure Sensor	Confirm that 5V Reference voltage is available on CCM. Check sensor voltage drop. Check for proper wiring between Compressor Discharge Pressure Sensor and CCM. Check for grounded sensor lead. Check for condensation inside of pressure sensor connector. See Table 5.
273	SENSOR FAULT	ECONOMIZER GAS TEMPERATURE (P Compressor)	273->Sensor Fault: Check Economizer Gas Temp Sensor	Check connection on and to EXV board J3-1 and J3-2. Confirm reading of 5000 ohm thermistor. Check for any loose connections.

Table 19 — ICVC Primary and Secondary Messages and Custom Alarm/Alert Messages with Troubleshooting Guides (cont)

I. CHILLER PROTECTIVE LIMIT FAULTS

STATE	PRIMARY MESSAGE	SECONDARY MESSAGE	ALARM MESSAGE PRIMARY CAUSE	ADDITIONAL CAUSE/REMEDY
200	PROTECTIVE LIMIT	RECTIFIER POWER FAULT	200->Rectifier Power Fault: Check VFD Status	Check VFD FAULT CODE in VFD_HIST screen. See VFD FAULT CODES in Table 20.
201	PROTECTIVE LIMIT	INVERTER POWER FAULT	201->Inverter Power Fault: Check VFD Status	Check VFD FAULT CODE in VFD_HIST screen. See VFD FAULT CODES in Table 20 .
202	PROTECTIVE LIMIT	MOTOR AMPS NOT SENSED	202->Motor Amps Not Sensed — Average Load Current [VALUE]	Check main circuit breaker for trip. Check VFD FAULT CODE in VFD_HIST screen. See VFD FAULT CODES in Table 20. Check MOTOR RATED LOAD AMPS setting in VFD_CONF screen. See Table 5.
203	FAILURE TO START	MOTOR ACCELERATION FAULT	203->Motor Acceleration Fault — Average Load Current [VALUE]	Check starter for proper operation. Reduce Condenser pressure if possible. Check VFD FAULT CODE in VFD_HIST screen. See VFD FAULT CODES in Table 20. Check MOTOR RATED LOAD AMPS setting in VFD_CONF screen. See Table 5.
204	FAILURE TO STOP	VFD SHUTDOWN FAULT	204->VFD Shutdown Fault: Check Inverter Power Unit	Check VFD FAULT CODE in VFD_HIST screen. See VFD FAULT CODES in Table 20. See Table 5.
205	PROTECTIVE LIMIT	HIGH DC BUS VOLTAGE	205->High DC Bus Voltage: [VALUE] exceeded limit of [LIMIT]*	Check DC BUS VOLTAGE and VFD FAULT CODE in VFD_HIST screen. See VFD FAULT CODES in Table 20.
206	PROTECTIVE LIMIT	VFD FAULT	206->VFD Fault Code: [VALUE]; Check VFD Fault Code List	Check DC BUS VOLTAGE and VFD FAULT CODE in VFD_HIST screen. See VFD FAULT CODES in Table 20.
207	PROTECTIVE LIMIT	HIGH CONDENSER PRESSURE	207->High Cond Pressure trip. [VALUE] exceeded Switch Trippoint.	Check for electrical continuity across High Pressure Switch. Check connections at VFD A33 Gate Kill Terminals. Check for high condenser water temperatures, low water flow, fouled tubes. Check for division plate/gasket bypass. Check for noncondensables in refrigerant. Check Condenser Pressure transducer wiring and accuracy. See Table 5.
208	PROTECTIVE LIMIT	EXCESSIVE MOTOR AMPS	208->Percent Load Current [VALUE] exceeded limit of [LIMIT]*.	Check Load Currents in VFD_HIST screen. Check MOTOR RATED LOAD AMPS setting in VFD_CONF screen. Check condenser water flow. See Table 5.
209	PROTECTIVE LIMIT	LINE CURRENT IMBALANCE	209->Line Current Imbalance: Check VFD Fault History for Values.	Check LINE CURRENTS and VFD FAULT CODE in VFD_HIST screen. See VFD FAULT CODES in Table 20. Check LINE CURRENT IMBALANCE settings in VFD_CONF screen. Check power distribution bus. Consult power company. See Table 5.
210	PROTECTIVE LIMIT	LINE VOLTAGE DROPOUT	210->Single Cycle Line Voltage Dropout	Check LINE VOLTAGE and VFD FAULT CODE in VFD_HIST screen. See VFD FAULT CODES in Table 20. Check SINGLE CYCLE DROPOUT setting in VFD_CONF screen. See Table 5.
211	PROTECTIVE LIMIT	HIGH LINE VOLTAGE	211->High Percent Line Voltage [VALUE]	Check LINE VOLTAGE and VFD FAULT CODE in VFD_HIST screen. See VFD FAULT CODES in Table 20. See Table 5. Check distribution bus. Consult power company.
212	PROTECTIVE LIMIT	LOW LINE VOLTAGE	212->Low Percent Line Voltage [VALUE]	Check LINE VOLTAGE and VFD FAULT CODE in VFD_HIST screen. See VFD FAULT CODES in Table 20. See Table 5. Check distribution bus. Consult power company.
213	PROTECTIVE LIMIT	VFD MODULE RESET	213->VFD Module Power-On Reset When Running	Check LINE VOLTAGE and VFD FAULT CODE in VFD_HIST screen. See VFD FAULT CODES in Table 20.
214	PROTECTIVE LIMIT	POWER LOSS	214->Control Power Loss When Running	Check LINE VOLTAGE in VFD_HIST screen. Check control power voltage on ICVC terminal J1. See Table 5. Check distribution bus. Consult power company.

*[LIMIT] is shown on the ICVC as the temperature, pressure, voltage, etc., set point predefined or selected by the operator as an override, alert, or alarm condition. [VALUE] is the actual pressure, temperature, voltage, etc., at which the control tripped.

Table 19 — ICVC Primary and Secondary Messages and Custom Alarm/Alert Messages with Troubleshooting Guides (cont)

I. CHILLER PROTECTIVE LIMIT FAULTS (cont)

STATE	PRIMARY MESSAGE	SECONDARY MESSAGE	ALARM MESSAGE PRIMARY CAUSE	ADDITIONAL CAUSE/REMEDY
215	PROTECTIVE LIMIT	LOW DC BUS VOLTAGE	215->Low DC Bus Voltage: [VALUE] exceeded limit of [LIMIT]*	Check DC BUS VOLTAGE and VFD FAULT CODE in VFD_HIST screen. See VFD FAULT CODES in Table 20. See Table 5.
216	PROTECTIVE LIMIT	LINE VOLTAGE IMBALANCE	216->Line Voltage Imbalance; Check VFD Fault History for Values.	Check LINE VOLTAGE and VFD FAULT CODE in VFD_HIST screen. See VFD FAULT CODES in Table 20. See Table 5. Check power distribution bus. Check LINE VOLTAGE IMBALANCE settings in VFD_CONF screen.
217	PROTECTIVE LIMIT	MOTOR OVERLOAD TRIP	217->Motor Overload Trip; Check VFD configurations	Check LOAD CURRENT and VFD FAULT CODE in VFD_HIST screen. See VFD FAULT CODES in Table 20. Check MOTOR RATED LOAD AMPS in VFD_CONF screen. See Table 5.
218	PROTECTIVE LIMIT	VFD RECTIFIER OVERTEMP	218->VFD Rectifier Temp Exceeded; Check Cooling and VFD Config.	Check VFD FAULT CODE in VFD_HIST screen. See VFD FAULT CODES in Table 20. See Table 5. Check VFD refrigerant isolation valves and solenoid valve. Check cooling fan on bottom of VFD power module. Configure RECTIFIER TEMP OVERRIDE in SETUP1 screen.
219	PROTECTIVE LIMIT	VFD INVERTER OVERTEMP	219->VFD Inverter Temp Exceeded; Check Cooling and VFD Config.	Check VFD FAULT CODE in VFD_HIST screen. See VFD FAULT CODES in Table 20. See Table 5. Check VFD refrigerant isolation valves and solenoid valve. Check cooling fan on bottom of VFD power module. Configure INVERTER TEMP OVERRIDE in SETUP1 screen.
220	PROTECTIVE LIMIT	GROUND FAULT	220->Ground Fault Trip; Check Motor and Current Sensors	Check GROUND FAULT CURRENT and VFD FAULT CODE in VFD_HIST screen. See VFD FAULT CODES in Table 20. See Table 5.
221	PROTECTIVE LIMIT	MOTOR ROTATION REVERSED	221->Motor Rotation Reversed; Check Wiring from VFD to Motor	Check if discharge pressure sensor is out of range in CONTROL TEST screen. See Table 5. Check resistor between CCM J3-7 and J3-8.
222	PROTECTIVE LIMIT	LINE FREQUENCY TRIP	222->Line Frequency [VALUE]; Check Power Supply.	Check LINE FREQUENCY and VFD FAULT CODE in VFD_HIST screen. See VFD FAULT CODES in Table 20. See Table 5.
223	LOSS OF COMMUNICATION	WITH VFD GATEWAY MODULE	223->Loss of SIO Comm with VFD Gateway; Check VFG Module and Power	Check SIO communication harness between the Gateway and the J7 CCM connector. Check status lights on CCM and Gateway per Fig. 63 and 65.
224	PROTECTIVE LIMIT	VFD COMMUNICATIONS FAULT	224->Loss of DPI Comm with VFD Gateway; Check VFG to VFD Comm.	Check ribbon cable and connectors between the Gateway and the VFD DPI Communications Interface Board per Fig. 64 and 65.
225	PROTECTIVE LIMIT	MOTOR CURRENT IMBALANCE	225->Motor Current Imbalance; Check VFD Fault History for Values.	Check LOAD CURRENT and VFD FAULT CODE in VFD_HIST screen. See VFD FAULT CODES in Table 20. See Table 5. Check power distribution bus. Check MOTOR CURRENT IMBALANCE settings in VFD_CONF screen.
226	PROTECTIVE LIMIT	LINE PHASE REVERSAL	226->Line Phase Reversal; Check Line Phases	Check VFD FAULT CODE in VFD_HIST screen. See VFD FAULT CODES in Table 20.
227	PROTECTIVE LIMIT	OIL PRESS SENSOR FAULT	227->Oil Pressure Delta P [VALUE] (Pump Off): Check Pump/Transducers	See Table 5. Select OIL PRESSURE DELTA P in COMPRESS screen to calibrate sensors. Check OIL SUMP PRESSURE and OIL PRESSURE LEAVING FILTER pressure transducer wiring and voltage drop. Check oil line isolation valves.

*[LIMIT] is shown on the ICVC as the temperature, pressure, voltage, etc., set point predefined or selected by the operator as an override, alert, or alarm condition. [VALUE] is the actual pressure, temperature, voltage, etc., at which the control tripped.

Table 19 — ICVC Primary and Secondary Messages and Custom Alarm/Alert Messages with Troubleshooting Guides (cont)

I. CHILLER PROTECTIVE LIMIT FAULTS (cont)

STATE	PRIMARY MESSAGE	SECONDARY MESSAGE	ALARM MESSAGE PRIMARY CAUSE	ADDITIONAL CAUSE/REMEDY
228	PROTECTIVE LIMIT	LOW OIL PRESSURE	228->Low Operating Oil Pressure [VALUE]; Check Oil Pump and Filter	Check oil level in Oil Sump sight glasses. Check OIL SUMP PRESSURE and OIL PRESSURE LEAVING FILTER transducer wiring and voltage drop. See Table 5. Check power supply to pump and pump operation. Look for oil flow through vaporizer drain sight glass when chiller is running. Check for partially closed isolation valves. Check oil filter. Check for foaming oil at start-up in oil sump. Check OIL PRESSURE DELTA P transducer calibration in COMPRESS screen. Check vaporizer and oil sump heaters and contactors.
229	PROTECTIVE LIMIT	LOW CHILLED LIQUID FLOW	229->Low Chilled Liquid Flow; Check Switch/Delta P Config & Calibration	Perform Pump Control Test in CONTROLS TEST screen. Check EVAP REFRIG LIQUID TEMP and LEAVING CHILLER LIQUID sensor accuracy and wiring. See Table 5. Check chilled liquid valves, pumps, and strainers. Check EVAP REFRIG TRIPPOINT, EVAP APPROACH ALERT, and EVAP FLOW DELTA P CUTOUT, and LIQUID FLOW VERIFY TIME settings. Check optional liquid flow switches or liquid delta P transducer calibration.
230	PROTECTIVE LIMIT	LOW CONDENSER LIQUID FLOW	230->Low Condenser Liquid Flow; Check Switch/Delta P Config & Calibration	Perform Pump Control Test in CONTROLS TEST screen. See Table 5. Check CONDENSER PRESSURE and LEAVING COND LIQUID sensors accuracy and wiring. Check condenser liquid valves, pumps, and strainers. Check COND APPROACH ALERT, COND PRESS OVERRIDE, LIQUID FLOW VERIFY TIME, and COND FLOW DELTA P CUTOUT settings. Check optional liquid flow switches or liquid delta P transducer calibration.
231	PROTECTIVE LIMIT	HIGH DISCHARGE TEMP	231->Comp Discharge Temp [VALUE] Exceeded Limit of [LIMIT]*	Check discharge isolation valve position. See Table 5. Check COMP DISCHARGE TEMP sensor resistance or voltage drop. Check for proper COMP DISCHARGE TEMP sensor wiring. Check for proper condenser flow and temperature. Check for fouled tubes, plugged liquid strainers or noncondensables in the system.
232	PROTECTIVE LIMIT	LOW REFRIGERANT TEMP	232->Evaporator Refrig Temp [VALUE] exceeded limit of [LIMIT]*.	Alarm declared when chiller is running, see Table 5. Check Cooler Refrig Liquid Line Isolation Valve Position. Check for proper refrigerant charge. Check Condenser Float Valve operation, check if CHILLED LIQUID APPROACH decreases when CONDENSER PRESSURE increases. Check EVAP APPROACH ALERT setting. Check for proper fluid flow and temperature against chiller design conditions.
233	PROTECTIVE LIMIT	HIGH MOTOR TEMPERATURE	233->Comp Motor Winding Temp [VALUE] exceeded limit of [LIMIT]*.	Check COMP MOTOR WINDING TEMP sensor wiring and accuracy. See Table 5. Check motor cooling line for proper operation, restrictions, and isolation valve position. Check motor cooling filter/drier and look for refrigerant flow through motor cooling sight glass. Check for excessive starts within a short time span. The high motor temperature switch in the windings or the motor temperature sensor circuit is open if COMP MOTOR WINDING TEMP = 245 F(118 C).

*[LIMIT] is shown on the ICVC as the temperature, pressure, voltage, etc., set point predefined or selected by the operator as an override, alert, or alarm condition. [VALUE] is the actual pressure, temperature, voltage, etc., at which the control tripped.

Table 19 — ICVC Primary and Secondary Messages and Custom Alarm/Alert Messages with Troubleshooting Guides (cont)

I. CHILLER PROTECTIVE LIMIT FAULTS (cont)

STATE	PRIMARY MESSAGE	SECONDARY MESSAGE	ALARM MESSAGE PRIMARY CAUSE	ADDITIONAL CAUSE/REMEDY
234	PROTECTIVE LIMIT	LOW OIL PRESSURE	234->Low Prelube Oil Press [VALUE]: Check Oil Pump & Filter	Check for low oil level in oil sump sight glass. See Table 5. Refrigerant has not been adequately removed from the oil if bubbling can be observed through oil sump sight glass. Check vaporizer and oil sump heaters and contactors. Check OIL PRESS VERIFY TIME.
235	PROTECTIVE LIMIT	HIGH CONDENSER PRESSURE	235->Condenser Pressure [VALUE] exceeded limit of [LIMIT]*.	Check for high condenser liquid temperatures against chiller design conditions. See Table 5. Check Condenser Approach in HEAT_EX screen. Check for low liquid flow, plugged liquid strainers, and fouled tubes. Check for division plate/gasket bypass. Check for noncondensables in refrigerant. Check CONDENSER PRESSURE transducer wiring and accuracy. Configure COND PRESS OVERRIDE in SETUP1 screen.
236	PROTECTIVE LIMIT	CCN OVERRIDE STOP	236->CCN Emergency/Override Stop	CCN has signaled the chiller to stop. EMERGENCY STOP in the MAINSTAT screen has been set to EMSTOP. Reset and restart when ready. If the signal was sent by the ICVC, release the stop signal on the STATUS01 table.
237	PROTECTIVE LIMIT	SPARE SAFETY DEVICE	237->Spare Safety Device	Spare safety input has tripped or factory-installed jumper is not present between terminals 19 and 20 on the Low Voltage Field Wiring Terminal Strip.
238	PROTECTIVE LIMIT	COMPRESSOR MOTOR STALL	238->Compressor Stall: Check Compressor and Motor	Check condenser liquid flow and temperatures against chiller design conditions. See Table 5. Check STALL TIME PERIOD and STALL % AMPs settings. Check for excessive refrigerant charge and oil loss.
239	PROTECTIVE LIMIT	TRANSDUCER VOLTAGE FAULT	239->Transducer Voltage Ref [VALUE] exceeded limit of [LIMIT]*.	Check If CCM PRESSURE TRANSDUCER VOLTAGE REFERENCE is less than 4.5 V in CONTROLS TEST screen. Confirm PRESSURE TRANSDUCER VOLTAGE REFERENCE across a CCM Pressure Transducer (e.g., CCM J3-1 to J3-3). Confirm that none of the transducers have been shorted to ground. Look for changes in voltage if customer wiring to CCM J5-1 through J5-6 and J8-1 to J8-2 are temporarily removed. Check for 24 VAC across CCM terminals J1-1 and J1-2.
240	VFD GATEWAY	COMPATIBILITY CONFLICT	240->VFD Gateway Compatibility Conflict: Check VFG/ICVC Versions	ICVC and Gateway software compatibility numbers do not match. See ICVC SOFTWARE PART # in ICVC CONFIGURATION SCREEN. See VFD GATEWAY VERSION # in VFD_STAT screen.
241	PROTECTIVE LIMIT	RECTIFIER OVERCURRENT	241->Rectifier Overcurrent Fault: Check VFD Status	Check LOAD CURRENT and VFD FAULT CODE in VFD_HIST screen. See VFD FAULT CODES in Table 20.
242	LOSS OF COMMUNICATION	WITH CCM MODULE	242->Loss of Communication With CCM: Check Comm. Connectors	Check wiring and connectors between CCM terminal J6 and ICVC terminal J7. Check CCM status lights. Check for 24V control power to CCM J1-1 and J1-2. Confirm that all CCM SW1 switches are in the "off" position.
243	POTENTIAL FREEZE-UP	EVAP PRESS/TEMP TOO LOW	243->Evaporator Refrig Temp [VALUE] exceeded limit of [LIMIT]*.	Alarm declared at power up and after chiller is shutdown, see Table 5. Check EVAPORATOR PRESSURE transducer. Check EVAP REFRIG TRIP POINT. Check for proper refrigerant charge. Check float operation. Check for proper evaporator fluid flow and temperature.
244	POTENTIAL FREEZE-UP	COND PRESS/TEMP TOO LOW	244->Condenser Refrig Temp [VALUE] exceeded limit of [LIMIT]*.	Alarm declared when chiller in shutdown, see Table 5. Check CONDENSER PRESSURE transducer. Check CONDENSER FREEZE POINT setting.

*[LIMIT] is shown on the ICVC as the temperature, pressure, voltage, etc., set point predefined or selected by the operator as an override, alert, or alarm condition. [VALUE] is the actual pressure, temperature, voltage, etc., at which the control tripped.

Table 19 — ICVC Primary and Secondary Messages and Custom Alarm/Alert Messages with Troubleshooting Guides (cont)

I. CHILLER PROTECTIVE LIMIT FAULTS (cont)

STATE	PRIMARY MESSAGE	SECONDARY MESSAGE	ALARM MESSAGE PRIMARY CAUSE	ADDITIONAL CAUSE/REMEDY
245	PROTECTIVE LIMIT	VFD SPEED OUT OF RANGE	245->Actual VFD Speed exceeded limit of Target VFD Speed $\pm 10\%$.*	Check if ACTUAL VFD SPEED exceeds VFD SPEED OUTPUT $\pm 10\%$ in COMPRESS or CAPACITY screen. See Table 5. Check for VFD FAULT CODES in VFD_HIST screen.
246	PROTECTIVE LIMIT	INVERTER OVERCURRENT	246->Inverter Overcurrent Fault: Check VFD Status	Check LINE CURRENTs and VFD FAULT CODE in VFD_HIST screen. See VFD FAULT CODES in Table 20.
247	PROTECTIVE LIMIT	VFD START INHIBIT	247->VFD Start Inhibit: Check VFD Diagnostic Parameters 212/214	Check VFD FAULT CODE in VFD_HIST screen. See VFD FAULT CODES in Table 20.
248	PROTECTIVE LIMIT	SPARE TEMPERATURE #1	248->Spare Temperature #1 [VALUE] exceeded limit of [LIMIT]*.	Check component that SPARE TEMPERATURE #1 is monitoring. See Table 5. Check SPARE TEMPERATURE #1 settings in SETUP1 screen. Check SPARE TEMPERATURE #1 sensor resistance or voltage drop on CCM terminals J4-25 and J4-26. Check SPARE TEMPERATURE #1 sensor wiring.
249	PROTECTIVE LIMIT	SPARE TEMPERATURE #2	249->Spare Temperature #2 [VALUE] exceeded limit of [LIMIT]*.	Check component that SPARE TEMPERATURE #2 is monitoring. See Table 5. Check SPARE TEMPERATURE #2 settings in SETUP1 screen. Check SPARE TEMPERATURE #2 sensor resistance or voltage drop on CCM terminals J4-27 and J4-28. Check SPARE TEMPERATURE #2 sensor wiring.
250	PROTECTIVE LIMIT	REFRIGERANT LEAK SENSOR	250->Refrigerant Leak Sensor ppm [VALUE] exceeded Limit of [LIMIT]*	REFRIGERANT LEAK OPTION is enabled. The refrigerant leak detector output wired to CCM terminals J5-5 and J5-6 has reached the alarm threshold (PPM AT 20 MA). See Table 5. Check for leaks. Check leak detector. Check REFRIGERANT LEAK OPTION, REFRIG LEAK ALARM PPM and PPM AT 20 MA settings in OPTIONS screen.
251	PROTECTIVE LIMIT	VFD CONFIG CONFLICT	251->VFD Config Conflict; Verify & Save VFD Config Data to Reset	VFD Parameters stored in Gateway and ICVC are not consistent. Enter VFD_CONF screen and check settings stored in ICVC against Machine Electrical Data Nameplate. If parameter values are unacceptable, exit VFD_CONF by pressing cancel. Re-enter VFD_CONF screen and check settings uploaded from Gateway against Machine Electrical Data Nameplate. Press SAVE before exiting VFD_CONF.
253	PROTECTIVE LIMIT	VFD CHECKSUM ERROR	253->Checksum Error: Press Reset to Restore Configuration	VFD inverter or rectifier checksum must be regenerated. Check VFD FAULT CODE in VFD_HIST screen. See VFD FAULT CODES in Table 20. Press RESET softkey on ICVC to restore VFD configuration.
254	PROTECTIVE LIMIT	VFD DEW PREVENTION	254->VFD Dew Prevention - VFD Coolant too Cold, Check Solenoid and Cond T	Reducing VFD COOLANT FLOW to 0% did not adequately increase VFD COLDPLATE TEMP. Check HUMIDITY SENSOR INPUT on CCM J3-7, J3-9 and J4-10 and RELATIVE HUMIDITY in POWER or CONTROLS TEST screen. Check humidity sensor wiring on CCM. Check VFD refrigerant cooling solenoid operation. Increase Entering Condenser Liquid Temperature. Reduce humidity surrounding chiller. Check that VFD A34 NTC cold plate thermocouple is wired to VFD A12 AC LINE I/O card TB1-19 and TB1-20.
255	PROTECTIVE LIMIT	INDUCTOR OVERTEMP	255->Inductor Overtemp Trip - Check Temp Switch and Cooling Fans	Temperature switch in VFD inductor has opened. Middle Control Center door must be fully closed to properly route airflow around VFD inductors. Check wiring to inductor temperature switch. Check inductor cooling fan operation. Check for inductor cooling fan airflow obstructions. Check VFD FAULT CODE in VFD_HIST screen. See VFD FAULT CODES in Table 20.
256	VFD GATEWAY	COMPATIBILITY CONFLICT	256->VFD Gateway Compatibility Conflict: Check VFG/VFD Versions	VFD INVERTER VERSION # and/or VFD RECTIFIER VERSION # are not compatible with the GATEWAY VERSION #. Check software version numbers in VFD_STAT screen.

*[LIMIT] is shown on the ICVC as the temperature, pressure, voltage, etc., set point predefined or selected by the operator as an override, alert, or alarm condition. [VALUE] is the actual pressure, temperature, voltage, etc., at which the control tripped.

Table 19 — ICVC Primary and Secondary Messages and Custom Alarm/Alert Messages with Troubleshooting Guides (cont)

J. CHILLER ALERTS				
STATE	PRIMARY MESSAGE	SECONDARY MESSAGE	ALARM MESSAGE PRIMARY CAUSE	ADDITIONAL CAUSE/REMEDY
140	SENSOR ALERT	LEAVING COND LIQUID TEMP	140->Sensor Fault: Check Leaving Cond Liquid Sensor	Temperature sensor reading out of range. Check LEAVING COND LIQUID TEMP sensor resistance or voltage drop at CCM. Check for grounded sensor leads. Check for proper wiring. See Table 5.
141	SENSOR ALERT	ENTERING COND LIQUID TEMP	141->Sensor Fault: Check Entering Cond Liquid Sensor	Temperature sensor reading out of range. Check ENTERING COND LIQUID TEMP sensor resistance or voltage drop at CCM. Check for grounded sensor leads. Check for proper wiring. See Table 5.
142	SENSOR ALERT	LOW OIL PRESSURE	142->Oil Pressure Delta P [VALUE] Exceeded Limit of [LIMIT]	Check for partially or closed oil line isolation valves. Check oil filter. Check oil level. Check Oil Pressure Leaving Filter and Oil Sump Pressure transducer wiring and OIL PRESSURE DELTA P accuracy. See Table 5.
143	AUTORESTART PENDING	LINE CURRENT IMBALANCE	143->Line Current Imbalance: Check VFD Fault History for Values	Chiller automatically restarting - AUTORESTART OPTION is enabled. Power loss has been detected in any phase. Check LINE CURRENTs and VFD FAULT CODE in VFD_HIST screen. See VFD FAULT CODES in Table 20. Check LINE CURRENT IMBALANCE settings in VFD_CONF screen. See Table 5. Check power distribution bus. Consult power company.
144	AUTORESTART PENDING	LINE VOLTAGE DROP OUT	144->Single Cycle Line Voltage Dropout	Chiller is automatically restarting - AUTORESTART OPTION is enabled. A drop in line voltage has been detected within 2 voltage cycles. Check LINE VOLTAGE and VFD FAULT CODE in VFD_HIST screen. See VFD FAULT CODES in Table 20. See Table 5. Check SINGLE CYCLE DROPOUT setting in VFD_CONF screen.
145	AUTORESTART PENDING	HIGH LINE VOLTAGE	145>High Percent Line voltage [VALUE]	Chiller is automatically restarting - AUTORESTART OPTION is enabled. Check LINE VOLTAGE and VFD FAULT CODE in VFD_HIST screen. See VFD FAULT CODES in Table 20. See Table 5. Check distribution bus. Consult power company.

*[LIMIT] is shown on the ICVC as the temperature, pressure, voltage, etc., set point predefined or selected by the operator as an override, alert, or alarm condition. [VALUE] is the actual pressure, temperature, voltage, etc., at which the control tripped.

Table 19 — ICVC Primary and Secondary Messages and Custom Alarm/Alert Messages with Troubleshooting Guides (cont)

J. CHILLER ALERTS (cont)

STATE	PRIMARY MESSAGE	SECONDARY MESSAGE	ALARM MESSAGE PRIMARY CAUSE	ADDITIONAL CAUSE/REMEDY
146	AUTORESTART PENDING	LOW LINE VOLTAGE	146->Low Percent Line voltage [VALUE]	Chiller is automatically restarting - AUTORESTART OPTION is enabled. Check LINE VOLTAGE and VFD FAULT CODE in VFD_HIST screen. See VFD FAULT CODES in Table 20. See Table 5. Check distribution bus. Consult power company.
147	AUTORESTART PENDING	VFD MODULE RESET	147->VFD Module Power-On Reset When Running	Chiller is automatically restarting - AUTORESTART OPTION is enabled. VFD Module has detected a hardware fault and has reset. Check LINE VOLTAGE and VFD FAULT CODE in VFD_HIST screen. See VFD FAULT CODES in Table 20.
148	AUTORESTART PENDING	POWER LOSS	148->Control Power-Loss When Running	Chiller is automatically restarting - AUTORESTART OPTION is enabled. Check LINE VOLTAGE in VFD_HIST screen. Check 24 vac control power voltage on ICVC terminals J1-4 and J1-5. See Table 5. Check distribution bus. Consult power company.
149	AUTORESTART PENDING	LOW DC BUS VOLTAGE	149->Low DC Bus Voltage: [VALUE] Exceeded Limit of [LIMIT]*	Chiller is automatically restarting - AUTORESTART OPTION is enabled. Check DC BUS VOLTAGE and VFD FAULT CODE in VFD_HIST screen. See VFD FAULT CODES in Table 20. See Table 5.
150	AUTORESTART PENDING	HIGH DC BUS VOLTAGE	150->High DC Bus Voltage: [VALUE] Exceeded Limit of [LIMIT]*	Chiller is automatically restarting - AUTORESTART OPTION is enabled. Check DC BUS VOLTAGE and VFD FAULT CODE in VFD_HIST screen. See VFD FAULT CODES in Table 20. See Table 5. Check input power for high voltage transients.
151	CONDENSER PRESSURE ALERT	PUMP RELAY ENERGIZED	151->High Condenser Pressure [VALUE]: Pump Energized to Reduce Pressure.	Check COND PRESS OVERRIDE in SETUP1 screen. Check CONDENSER PRESSURE sensor wiring and accuracy. Check condenser liquid flow, strainers, and condenser liquid temperature. Check for fouled tubes. This alarm is not caused by the High Pressure Switch.
152	RECYCLE ALERT	EXCESSIVE RECYCLE STARTS	152->Excessive recycle starts.	Chiller load is too low to keep compressor on line and there has been more than 5 starts in 4 hours. Check HGBP Isolation valve position. Increase chiller load. Adjust hot gas bypass parameters in OPTIONS screen. Increase (RECYCLE CONTROL) RESTART DELTA T in SETUP1 Screen.
153	no message: ALERT only	no message; ALERT only	153->Lead/Lag Disabled: Duplicate Chiller Address; Check Configuration	Illegal chiller address configuration in Lead/Lag screen, see Table 7. Check chiller addresses in LEAD/LAG and ICVC CONFIGURATION screens.
154	POTENTIAL FREEZE-UP	COND PRESS/TEMP TOO LOW	154->Condenser freeze up prevention	The chiller is not in pumpdown mode and the condenser pressure transducer is reading a pressure that could freeze the condenser tubes. Check CONDENSER FREEZE POINT setting. See Table 5. Check for condenser refrigerant leaks. Check condenser liquid temperature. Check CONDENSER PRESSURE sensor wiring and accuracy on CCM terminals J2-4, J2-5 and J2-6. Place the chiller in PUMPDOWN mode if the vessel is evacuated.

*[LIMIT] is shown on the ICVC as the temperature, pressure, voltage, etc., set point predefined or selected by the operator as an override, alert, or alarm condition. [VALUE] is the actual pressure, temperature, voltage, etc., at which the control tripped.

Table 19 — ICVC Primary and Secondary Messages and Custom Alarm/Alert Messages with Troubleshooting Guides (cont)

J. CHILLER ALERTS (cont)

STATE	PRIMARY MESSAGE	SECONDARY MESSAGE	ALARM MESSAGE PRIMARY CAUSE	ADDITIONAL CAUSE/REMEDY
155	OPTION SENSOR FAULT	REMOTE RESET SENSOR	155->Sensor Fault/Option Disabled: Remote Reset Sensor	Type 2 Temperature Reset is enabled and Remote Reset sensor on CCM J4-13 and J4-14 is out of range. Check Temperature Reset settings in TEMP_CNTL screen. Check REMOTE RESET sensor resistance or voltage drop. Check for proper REMOTE RESET sensor wiring.
156	OPTION SENSOR FAULT	AUTO CHILLED LIQUID RESET	156->Sensor Fault/Option Disabled: Auto Chilled Liquid Reset	Type 1 Temperature Reset is enabled and Auto Chilled Water Reset input on CCM J5-3 and J5-4 is < 2 mA. Check Temperature Reset settings in TEMP_CNTL screen. Check that Auto Chilled Liquid Reset input is between 4 mA and 20 mA.
157	OPTION SENSOR FAULT	AUTO DEMAND LIMIT INPUT	157->Sensor Fault/Option Disabled: Auto Demand Limit Input	20 mA DEMAND LIMIT OPTION is enabled and Auto Demand Limit input on CCM J5-1 and J5-2 is < 2 mA. Check 20 mA DEMAND LIMIT setting in RAMP_DEM screen. Check that Auto Demand Limit input is between 4 mA and 20 mA.
158	SENSOR ALERT	SPARE TEMPERATURE #1	158->Spare Temperature #1 [VALUE] exceeded limit of [LIMIT].*	Check component that SPARE TEMPERATURE #1 is monitoring. Check SPARE TEMPERATURE #1 settings in SETUP1 screen. Check SPARE TEMPERATURE #1 sensor resistance or voltage drop on CCM J4-25 and J4-26. Check for proper SPARE TEMPERATURE #1 wiring.
159	SENSOR ALERT	SPARE TEMPERATURE #2	159->Spare Temperature #2 [VALUE] exceeded limit of [LIMIT].*	Check component that SPARE TEMPERATURE #2 is monitoring. Check SPARE TEMPERATURE #2 settings in SETUP1 screen. Check SPARE TEMPERATURE #2 sensor resistance or voltage drop on CCM J4-27 and J4-28. Check for proper SPARE TEMPERATURE #2 wiring.
160	SENSOR ALERT	EVAPORATOR APPROACH	160->Evaporator Approach [VALUE] Exceeded Limit of [LIMIT]*	Check position of refrigerant liquid line isolation valve. Check EVAP APPROACH ALERT setting in SETUP1 screen. Check Evaporator Liquid Flow. See Table 5. Check EVAP REFRIG LIQUID TEMP and CHILLED LIQUID TEMP sensor resistances or voltage drops. Check for proper EVAP REFRIG LIQUID TEMP and CHILLED LIQUID TEMP sensor wiring. Check for oil loss. Check for low refrigerant charge. Check float valve operation and for refrigerant stacking in the condenser. Check for evaporator division plate bypass. Check for fouled tubes. Check for air in water box.
161	SENSOR ALERT	CONDENSER APPROACH	161->Condenser Approach [VALUE] Exceeded Limit of [LIMIT]*	Check COND APPROACH ALERT setting in SETUP1 screen. Check Condenser Liquid flow. See Table 5. Check CONDENSER PRESSURE and LEAVING COND LIQUID temperature sensor resistances or voltage drops. Check for proper CONDENSER PRESSURE and LEAVING COND LIQUID temperature sensor wiring. Check condenser shell temperature against condenser pressure measured with refrigerant gage for evidence of noncondensables in refrigerant charge. Check for condenser division plate bypass. Check for fouled condenser tubes. Check for air in water box.

*[LIMIT] is shown on the ICVC as the temperature, pressure, voltage, etc., set point predefined or selected by the operator as an override, alert, or alarm condition. [VALUE] is the actual pressure, temperature, voltage, etc., at which the control tripped.

Table 19 — ICVC Primary and Secondary Messages and Custom Alarm/Alert Messages with Troubleshooting Guides (cont)

J. CHILLER ALERTS (cont)

STATE	PRIMARY MESSAGE	SECONDARY MESSAGE	ALARM MESSAGE PRIMARY CAUSE	ADDITIONAL CAUSE/REMEDY
162	SENSOR ALERT	HIGH DISCHARGE TEMP	162->Comp Discharge Temp [VALUE] Exceeded Limit of [LIMIT]*	Check position of condenser isolation valve. Check COMP DISCHARGE ALERT setting in SETUP1 screen. See Table 5. Check COMP DISCHARGE TEMP sensor resistance or voltage drop. Check for proper condenser liquid flow and temperature. Check for proper wiring. Check for fouled tubes, plugged strainers, or noncondensables in the refrigerant.
163	LOSS OF COMMUNICATION	WITH WSM	163->WSM Cool Source - Loss of Communication	Communications interrupted between supervisory component and equipment component of WSM (Water System Manager). Check settings in WSMDEFME screen. Check CCN communications link with WSM. Check supervisory part of WSM.
164	SYSTEM ALERT	HIGH OIL PRESSURE	164->High Oil Pressure [VALUE], Check Oil Regulator and Valves	See Table 5. Check oil pressure regulator isolation valve. Check oil pressure regulator. Check for bent oil lines. Check Oil Sump Pressure and Oil Pressure Leaving filter transducer resistances or voltage drops. Check OIL PRESSURE DELTA P wiring to CCM. Check for debris in Compressor Inlet Bearing Oil Orifice Strainers. Normal alert if chiller was charged and started within a few hours of pulling dehydration vacuum with oil heater on.
165	AUTORESTART PENDING	VFD COMMUNICATIONS FAULT	165-> Loss of DPI Comm With VFD Gateway, Check VFG to VFD Comm	Check that the gateway board is properly connected to the DPI. Check ribbon cable. Make sure both boards have power to them.
166	AUTORESTART PENDING	VFD COMMUNICATIONS FAULT	166-> Loss of SIO Comm With VFD Gateway; Check VFG module and Power	Check the SIO communication cable from the CCM board to the power panel, then the cable from the power panel to the VFD gateway. Check power to the VFD (main circuit breaker may be tripped)
168	SENSOR ALERT	HUMIDITY SENSOR INPUT	168->Sensor Fault: Check Humidity Sensor Input	See Table 5. Humidity Sensor Input voltage is outside of 0.5 V to 4.5 V range. Check Humidity Sensor wiring to CCM terminals J3-7, J3-9, and J4-10. Check Humidity Sensor Input in Controls Test screen. Check resistance 4.3 kohm load resistor between CCM J3-7 and J3-8.
169	MACHINE ALERT	CONDENSER LIQUID LEVEL LOW	169->Sensor Fault: Condenser Liquid Level Low	Check EXV operation.
170	MACHINE ALERT	CONDENSER LIQUID LEVEL HIGH	170->Sensor Fault: Condenser Liquid Level High	Check EXV operation.

*[LIMIT] is shown on the ICVC as the temperature, pressure, voltage, etc., set point predefined or selected by the operator as an override, alert, or alarm condition. [VALUE] is the actual pressure, temperature, voltage, etc., at which the control tripped.

Table 20 — VFD Fault Description and Corrective Actions

FAULT CODE	FAULT	TYPE*	DESCRIPTION	ACTION	FAULT STATE
2	Auxiliary Input	1	Input is open.	Check remote wiring.	206
3	Power Loss	1, 3	DC bus voltage remained below 85% of nominal for longer than Power Loss Time (185). Enable/disable with Fault Config 1 (238).	Monitor the incoming AC line for low voltage or line power interruption.	149 215
4	UnderVoltage	1, 3	DC bus voltage fell below the minimum value of 407V DC at 400/480V input.	Monitor the incoming AC line for low voltage or power interruption.	149 215
5	OverVoltage	1	DC bus voltage exceeded maximum value.	Monitor the AC line for high line voltage or transient conditions. Extend the decel time or check RATED LINE VOLTAGE setting.	150 205
7	Motor Overload	1, 3	Internal electronic overload is set to trip when the motor current equals 135% of Motor NP FLA(42) for 1.5 seconds or when PERCENT LOAD CURRENT is sustained above 108%.	An excessive motor load exists. Reduce load so drive output current does not exceed the MOTOR NAMEPLATE AMPS setting.	217
8	Invtr Base Temp	1	Base temperature exceeded limit.	1. Check operation of VFD cooling solenoid, VFD isolation valves, and humidity sensor. 2. Check for proper temperature and flow rate of coolant.	219
9	Invtr IGBT Temp	1	Output transistors have exceeded their maximum operating temperature.	1. Check operation of VFD cooling solenoid, VFD isolation valves, and humidity sensor. 2. Check for proper temperature and flow rate of coolant.	219
12	HW OverCurrent	1	The drive output current has exceeded the hardware current limit.	Check programming. Check for excess load. Contact Carrier Service.	246
13	Ground Fault	1	A current path to earth ground in excess of 7% of drive rated amps has been detected at one or more of the drive output terminals.	Check the motor and external wiring to the drive output terminals for a grounded condition.	220
24	Decel Inhibit	3	The drive is not following a commanded deceleration because it is attempting to limit bus voltage.	1. Verify input voltage is within drive specified limits. 2. Verify system ground impedance follows proper grounding techniques.	204
25	OverSpeed Limit	1	Functions such as slip compensation or bus regulation have attempted to add an output frequency adjustment greater than that programmed in Overspeed Limit (83).	Remove excessive load conditions.	206
29	Analog In Loss	1, 3	An analog input is configured to fault on signal loss. A signal loss has occurred. Configure with Anlg In 1, 2 Loss (324, 327).	1. Check parameters. 2. Check for broken/loose connections at inputs.	206
33	Auto Rstrt Tries	3	Drive unsuccessfully attempted to reset a fault.	1. Correct the cause of the fault and manually clear. 2. Check parameters in VFD_CONF screen	206
35	Current Fbk Lost	4	The magnitude of motor current feedback was less than 5% Motor NP FLA (42) for the time configured in Imbalance Time (50). Detection of this fault is disabled when Imbalance Time (50) is set to the maximum value of 10.0 seconds.	1. Verify connection of current feedback device and motor terminals. 2. If fault repeats, replace current feedback devices and/or power supply. 3. Check VFD_CONF screen parameters.	206
36	SW OverCurrent	1	The drive output current has exceeded the software current.	1. Check for excess load.	246
37	Motor I Imbalance	4	Phase current displayed in Imbalance Display (221) > percentage set in Imbalance Limit (49) for time set in Imbalance Time (50).	1. Press ICVC RESET key to clear fault. 2. Check motor leads and terminals.	225
38	Phase U to Grnd	4	A phase-to-ground fault has been detected between the drive and motor in this phase.	1. Check the wiring between the drive and motor. 2. Check motor for grounded phase. 3. Contact Carrier Service.	220
39	Phase V to Grnd	4			
40	Phase W to Grnd	4			
41	Phase UV Short	4	Excessive current has been detected between these two output terminals.	1. Check the motor and drive output terminal wiring for a shorted condition. 2. Contact Carrier Service, replace drive.	220
42	Phase VW Short	4			
43	Phase UW Short	4			

*Fault Type indicates if the fault is:

- 1 — Auto-resettable
- 2 — Non-resettable
- 3 — User-configurable
- 4 — Normal Fault resettable using Carrier ICVC "RESET" softkey

NOTE: VFD Troubleshooting should only be performed by a Reliance Certified LiquiFlo2 technician.

Table 20 — VFD Fault Description and Corrective Actions (cont)

FAULT CODE	FAULT	TYPE*	DESCRIPTION	ACTION	FAULT STATE
48	Params Defaulted	4	The drive was commanded to write default values to EEPROM.	1. Press ICVC RESET key or cycle power to the VFD. 2. Program the drive parameters as needed.	206
63	Shear Pin	3	Programmed Current Lmt Val (148) has been exceeded. Enabled/disable with Fault Config 1 (238).	Check MOTOR RATED LOAD AMPS setting in VFD_CONF screen.	206
64	Drive OverLoad	4	Drive rating of 102% for 1 minute or 150% for 5 seconds has been exceeded.	Check RATED LINE AMPS and MOTOR RATED LOAD AMPS in VFD_CONF screen.	246
70	HW Fault	4	Inverter section of power module detected an unexpected fault during power stage diagnostics.	Contact Carrier Service	206
71- 75	Port 1-5 Net Loss	4	The network card connected to DPI port stopped communicating. The fault code indicates the offending port number (71 = port 1, 72 = port 2, etc.)	1. Check communication board for proper connection to external network. 2. Check external wiring to module on port. Check ribbon cables, connectors, and pins. 3. Verify external network fault.	206
77	IR Volts Range	4	The drive autotuning default is calculated, and the value calculated for IR Drop Volts is not in the range of acceptable values.	Check Motor Nameplate parameters in VFD_-CONF screen.	206
78	FluxAmpsRef Rang	4	The value for flux amps determined by the autotune procedure exceeds the programmed Motor NP FLA (42).	Check MOTOR NAMEPLATE AMPS in VFD_-CONF screen.	206
79	Excessive Load	4	Motor did not come up to speed in the allotted time.	1. Check parameters in VFD_CONF screen. 2. Contact Carrier Service.	203
80	AutoTune Aborted	4	The autotune procedure was canceled by the user.	Press ICVC RESET key to restart procedure.	206
81- 85	Port 1-5 DPI Loss	4	DPI port stopped communicating. An attached peripheral with control capabilities via Local Mask (288) (or OIM control) was removed. The fault code indicates the offending port number (81 = port 1, etc.)	1. If module was not intentionally disconnected, check ribbon cables, connectors, and pins. Replace wiring port expander, modules, Main Control Board or complete drive as required. 2. Check OIM connection if used.	206
87	Ixo Voltage Range	4	Ixo voltage calculated from motor nameplate data is too high	1. Press ICVC RESET key. 2. Contact Carrier Service.	206
100	Parameter Chksum	2	The checksum read from the board does not match the checksum calculated.	1. Press ICVC RESET key to restore defaults. 2. Cycle power to the VFD.	206
101	UserSet1 Chksum	2	The checksum read from the user set does not match the checksum calculated.	1. Press ICVC RESET key to restore defaults. 2. Cycle power to the VFD.	206
102	UserSet2 Chksum	2			
103	UserSet3 Chksum	2			
104	Pwr Brd Chksum1	4	The checksum read from the EEPROM does not match the checksum calculated from the EEPROM data.	1. Press ICVC RESET key to restore defaults. 2. Cycle power to the VFD.	206
105	Pwr Brd Chksum2	2	The checksum read from the board does not match the checksum calculated.	1. Cycle power to the VFD. 2. If problem persists, contact Carrier Service.	206
106	Incompat MCB-PB	2	Drive rating information stored on the power board is incompatible with the Main Control board.	Load compatible version files into drive.	206
107	Replaced MCB-PB	2	Main Control board was replaced and parameters were not programmed.	Program parameters into VFD_CONF screen.	206
120	I/O Board Mismatch	4	Incorrect I/O board identified.	Program parameters into VFD_CONF screen.	206
121	I/O Board Comm Loss	2	Loss of communication to I/O board.	1. Press ICVC RESET key. 2. Check VFD board ribbon cables and connector pins.	206
122	I/O Board Fail	4	Board failure.	1. Press ICVC RESET key, cycle power to the VFD. 2. If fault repeats, replace I/O board.	206
200 201 202	Inverter Dsat U, V, W	4	High current was detected in an IGBT.	1. Check for loose connection in IGBT wire harness. 2. Check IGBTs. 3. Check precharge resistors and fuses. 4. Check precharge contactor.	201

*Fault Type indicates if the fault is:

- 1 — Auto-resettable
- 2 — Non-resettable
- 3 — User-configurable
- 4 — Normal Fault resettable using Carrier ICVC "RESET" softkey

NOTE: VFD Troubleshooting should only be performed by a Reliance Certified LiquiFlo2 technician.

Table 20 — VFD Fault Description and Corrective Actions (cont)

FAULT CODE	FAULT	TYPE*	DESCRIPTION	ACTION	FAULT STATE
203 204 205	Inverter OverCurrent U, V, W	4	High current was detected in an IGBT.	Check parameters in VFD_CONF screen.	246
206	Invtr HW Unused	4	Inverter section of power structure hardware reported unexpected fault.	1. Verify connection between inverter control board and inverter power board. 2. If fault persists, replace inverter power board. 3.. If fault persists, replace inverter control board.	206
207	Invtr Gate Kill	4	Inverter gate kill contact is open.	1. Check that condenser high pressure switch is wired to the VFD gate kill contact. 2. Check that high pressure switch is closed.	207 235
208 209 210	Rectifier Dsat R, S, T	4	High current was detected in an IGBT.	1. Press RESET key on ICVC. 2. Contact Carrier Service.	200
211 212 213	Rectifier Over Cur R, S, T	4	Rectifier overcurrent	Check parameters in VFD_CONF screen.	241
214	Reactor Temp	4	Temperature switch in reactor opened.	Check for proper temperature and fan operation.	255
215	Rctfr HW Unused	4	Rectifier portion of power structure hardware reported unexpected fault	1. Verify connection between rectifier control board and rectifier power board. 2. If fault persists, replace rectifier power board. 3. If fault still persists, replace rectifier inverter control board.	206
216	Rectifier Ground Fault	4	Excessive ground current measured.	Check for grounded input wiring.	220
217	Rectifier Base Temp	4	Excessive rectifier temperature measured.	1. Check VFD cooling solenoid, VFD refrigerant strainer, and VFD isolation valves. 2. Check for proper temperature and flow rate of coolant.	218
218	Rectifier IGBT Temp	4	Excessive calculated IGBT temperature.	1. Check VFD cooling solenoid, VFD refrigerant strainer, and VFD isolation valves. 2. Check for proper temperature and flow rate of coolant.	218
219	Rectifier IT Overload	4	Short-term current rating of rectifier exceeded.	Low input voltage can result in increased current load. Provide proper input voltage to the drive.	146 212
220	Rectifier I ² T Overload	4	Long-term current rating of rectifier exceeded.	Low input voltage can result in increased current load. Provide proper input voltage to the drive.	146 212
221	Ride Thru Abort	4	Input power loss timed out.	1. Verify input power and connections. 2. Check Line Sync board, connectors and pins. 3. Check AC Line I/O board, connectors, and pins.	146 147 212 213
222	High AC Line	4	Input line voltage is too high.	Reduce input voltage to meet RATED LINE VOLTAGE ±10%.	145 211
223	Low DC Bus	4	The bus voltage is too low.	1. Verify proper input voltage. 2. Check control center and input power fuses.	149 215
224	Rctfr Over Volt	4	The bus voltage is too high.	Monitor the AC line for high line voltage or transient conditions. Extend the decel time.	150 205
225	Input Amp Imbalance	4	Input phase current imbalance exceeded limits.	1. Check for loose connection in input power wiring. 2. Check precharge contactors.	143 209
226	Input Volt Imbalance	4	Input voltage imbalance exceeded limits.	1. Check for problem in input power distribution. 2. Check input wiring connections.	216
227	AC Line Lost	4	Input power Lost	1. Verify proper input voltage. 2. Check line sync board and fuse. 3. Check AC line I/O board. 4. Verify connections between boards.	144 210
228	Line Frequency	4	Line frequency not in the range of 47-63 Hz.	Verify connection between AC Line Sync and AC Line I/O boards. Confirm that connectors are fully engaged.	222
229	Rectifier Checksum	4	The checksum read from the board does not match the checksum calculated.	1. Check all power module connectors and cycle power to the VFD. 2. Press ICVC RESET key to restore defaults. 3. Check parameters in VFD_CONF screen.	253
230	Invtr HW Unk	4	Inverter section of power structure hardware reported unexpected fault.	1. Verify connection between inverter control board and inverter power board. 2. If fault persists, replace inverter power board. 3. If fault still persists, replace inverter control board.	206

*Fault Type indicates if the fault is:

- 1 — Auto-resettable
- 2 — Non-resettable
- 3 — User-configurable
- 4 — Normal Fault resettable using Carrier ICVC “RESET” softkey

NOTE: VFD Troubleshooting should only be performed by a Reliance Certified LiquiFlo2 technician.

Table 20 — VFD Fault Description and Corrective Actions (cont)

FAULT CODE	FAULT	TYPE*	DESCRIPTION	ACTION	FAULT STATE
231	Rctfr HW Unk	4	Rectifier portion of power structure hardware reported unexpected fault.	1. Verify connection between rectifier control board and rectifier power board. 2. If fault persists, replace rectifier power board 3. If fault still persists, replace rectifier control board.	206
232	Rctfr Not OK	4	A fault was detected in the rectifier other than one specifically decoded.	Look at rectifier parameter 243 to see fault code. Contact Carrier.	200
233	Precharge closed	4	Precharge was closed when it should be open.	1. Check AUX contacts on precharge. Check if precharge contactor is energized. 2. Check input bit 0 in rectifier parameter 216 to view status of input. 3. Check wiring. 4. Check precharge resistors and fuses.	206
234	Precharge open	4	Precharge was open when it should be closed.	1. Check AUX contacts on precharge. Check if precharge contactor is de-energized. 2. Check input bit 0 in rectifier parameter 216 to view status of input. 3. Check wiring. 4. Check precharge resistors and fuses.	206
235	Rctfr Pwr Board	4	Drive rating information stored on the power board is incompatible with the Main Control board. The checksum read from the board does not match the checksum calculated.	Load compatible version files into drive. 1. Cycle power to the VFD. 2. If problem persists, contact Carrier Service.	206
236	Rctfr I/O Board	4	Loss of communication to I/O board. Board failure.	1. Cycle power to the VFD. 2. Check I/O board ribbon cables, connectors, and pins. 3. If fault repeats, replace I/O board.	206
237	Not at Voltage	4	The rectifier did not regulate to the desired bus voltage within the defined time.	1. Check all fuses and cabinet wiring. 2. Replace line synch board. 3. Replace AC Line I/O board. 4. Replace rectifier control board and/or rectifier power board.	149 215
238	Rectfr Not Logged In	4	Rectifier took too long to connect to inverter.	1. Check the cabling, connectors, and pins between the communications interface and the two control boards. 2. Verify the DPI Data Rate (270) is set to 500K. 3. Connect one DPI device at a time to determine if one of the DPI devices is causing the problem. 4. Replace the communications interface. 5. Replace the rectifier control board. 6. Swap 80W power supplies to determine if the fault follows the power supply. Replace the power supply if needed.	206
239	Power Phased ACB	4	Input Power is phased ACB rather than ABC.	Switch two of the input power phases.	226

*Fault Type indicates if the fault is:

- 1 — Auto-resettable
- 2 — Non-resettable
- 3 — User-configurable
- 4 — Normal Fault resettable using Carrier ICVC "RESET" softkey

NOTE: VFD Troubleshooting should only be performed by a Reliance Certified LiquiFlo2 technician.

Table 21 — Thermistor Temperature (F) vs Resistance/Voltage Drop

TEMPERATURE (F)	PIC III VOLTAGE DROP (V)	RESISTANCE (OHMS)	TEMPERATURE (F)	PIC III VOLTAGE DROP (V)	RESISTANCE (OHMS)	TEMPERATURE (F)	PIC III VOLTAGE DROP (V)	RESISTANCE (OHMS)
-25	4.700	97,706	66	2.565	6,568	157	0.630	893
-24	4.690	94,549	67	2.533	6,405	158	0.619	876
-23	4.680	91,474	68	2.503	6,246	159	0.609	859
-22	4.670	88,480	69	2.472	6,092	160	0.599	843
-21	4.659	85,568	70	2.440	5,942	161	0.589	827
-20	4.648	82,737	71	2.409	5,796	162	0.579	812
-19	4.637	79,988	72	2.378	5,655	163	0.570	797
-18	4.625	77,320	73	2.347	5,517	164	0.561	782
-17	4.613	74,734	74	2.317	5,382	165	0.551	768
-16	4.601	72,229	75	2.287	5,252	166	0.542	753
-15	4.588	69,806	76	2.256	5,124	167	0.533	740
-14	4.576	67,465	77	2.227	5,000	168	0.524	726
-13	4.562	65,205	78	2.197	4,880	169	0.516	713
-12	4.549	63,027	79	2.167	4,764	170	0.508	700
-11	4.535	60,930	80	2.137	4,650	171	0.499	687
-10	4.521	58,915	81	2.108	4,539	172	0.491	675
-9	4.507	56,981	82	2.079	4,432	173	0.484	663
-8	4.492	55,129	83	2.050	4,327	174	0.476	651
-7	4.477	53,358	84	2.021	4,225	175	0.468	639
-6	4.461	51,669	85	1.993	4,125	176	0.460	628
-5	4.446	50,062	86	1.965	4,028	177	0.453	616
-4	4.429	48,536	87	1.937	3,934	178	0.445	605
-3	4.413	47,007	88	1.909	3,843	179	0.438	595
-2	4.396	45,528	89	1.881	3,753	180	0.431	584
-1	4.379	44,098	90	1.854	3,667	181	0.424	574
0	4.361	42,715	91	1.827	3,582	182	0.418	564
1	4.344	41,380	92	1.800	3,500	183	0.411	554
2	4.325	40,089	93	1.773	3,420	184	0.404	544
3	4.307	38,843	94	1.747	3,342	185	0.398	535
4	4.288	37,639	95	1.721	3,266	186	0.392	526
5	4.269	36,476	96	1.695	3,192	187	0.385	516
6	4.249	35,354	97	1.670	3,120	188	0.379	508
7	4.229	34,270	98	1.644	3,049	189	0.373	499
8	4.209	33,224	99	1.619	2,981	190	0.367	490
9	4.188	32,214	100	1.595	2,914	191	0.361	482
10	4.167	31,239	101	1.570	2,849	192	0.356	474
11	4.145	30,298	102	1.546	2,786	193	0.350	466
12	4.123	29,389	103	1.523	2,724	194	0.344	458
13	4.101	28,511	104	1.499	2,663	195	0.339	450
14	4.079	27,663	105	1.476	2,605	196	0.333	442
15	4.056	26,844	106	1.453	2,547	197	0.328	435
16	4.033	26,052	107	1.430	2,492	198	0.323	428
17	4.009	25,285	108	1.408	2,437	199	0.318	421
18	3.985	24,544	109	1.386	2,384	200	0.313	414
19	3.960	23,826	110	1.364	2,332	201	0.308	407
20	3.936	23,130	111	1.343	2,282	202	0.304	400
21	3.911	22,455	112	1.321	2,232	203	0.299	393
22	3.886	21,800	113	1.300	2,184	204	0.294	387
23	3.861	21,163	114	1.279	2,137	205	0.290	381
24	3.835	20,556	115	1.259	2,092	206	0.285	374
25	3.808	19,967	116	1.239	2,047	207	0.281	368
26	3.782	19,396	117	1.219	2,003	208	0.277	362
27	3.755	18,843	118	1.200	1,961	209	0.272	356
28	3.727	18,307	119	1.180	1,920	210	0.268	351
29	3.700	17,787	120	1.161	1,879	211	0.264	345
30	3.672	17,284	121	1.143	1,840	212	0.260	339
31	3.644	16,797	122	1.124	1,801	213	0.256	334
32	3.617	16,325	123	1.106	1,764	214	0.252	329
33	3.588	15,868	124	1.088	1,727	215	0.248	323
34	3.559	15,426	125	1.070	1,691	216	0.245	318
35	3.530	14,997	126	1.053	1,656	217	0.241	313
36	3.501	14,582	127	1.036	1,622	218	0.237	308
37	3.471	14,181	128	1.019	1,589	219	0.234	303
38	3.442	13,791	129	1.002	1,556	220	0.230	299
39	3.412	13,415	130	0.986	1,524	221	0.227	294
40	3.382	13,050	131	0.969	1,493	222	0.224	289
41	3.353	12,696	132	0.953	1,463	223	0.220	285
42	3.322	12,353	133	0.938	1,433	224	0.217	280
43	3.291	12,021	134	0.922	1,404	225	0.214	276
44	3.260	11,699	135	0.907	1,376	226	0.211	272
45	3.229	11,386	136	0.893	1,348	227	0.208	267
46	3.198	11,082	137	0.878	1,321	228	0.205	263
47	3.167	10,787	138	0.864	1,295	229	0.203	259
48	3.135	10,500	139	0.849	1,269	230	0.198	255
49	3.104	10,221	140	0.835	1,244	231	0.195	251
50	3.074	9,949	141	0.821	1,219	232	0.192	248
51	3.042	9,689	142	0.808	1,195	233	0.190	244
52	3.010	9,436	143	0.795	1,172	234	0.187	240
53	2.978	9,190	144	0.782	1,149	235	0.184	236
54	2.946	8,951	145	0.769	1,126	236	0.182	233
55	2.914	8,719	146	0.756	1,104	237	0.179	229
56	2.882	8,494	147	0.744	1,083	238	0.176	226
57	2.850	8,275	148	0.731	1,062	239	0.174	223
58	2.819	8,062	149	0.719	1,041	240	0.172	219
59	2.788	7,855	150	0.707	1,021	241	0.169	216
60	2.756	7,655	151	0.696	1,002	242	0.167	213
61	2.724	7,460	152	0.684	983	243	0.164	210
62	2.692	7,271	153	0.673	964	244	0.162	207
63	2.660	7,088	154	0.662	945	245	0.160	204
64	2.628	6,909	155	0.651	928	246	0.158	201
65	2.596	6,736	156	0.640	910	247	0.155	198
						248	0.153	195

Table 22 — Thermistor Temperature (C) vs Resistance/Voltage Drop

TEMPERATURE (C)	PIC III VOLTAGE DROP (V)	RESISTANCE (OHMS)	TEMPERATURE (C)	PIC III VOLTAGE DROP (V)	RESISTANCE (OHMS)
-33	4.722	105 616	44	1.338	2 272
-32	4.706	99 640	45	1.300	2 184
-31	4.688	93 928	46	1.263	2 101
-30	4.670	88 480	47	1.227	2 021
-29	4.650	83 297	48	1.192	1 944
-28	4.630	78 377	49	1.158	1 871
-27	4.608	73 722	50	1.124	1 801
-26	4.586	69 332	51	1.091	1 734
-25	4.562	65 205	52	1.060	1 670
-24	4.538	61 343	53	1.029	1 609
-23	4.512	57 745	54	0.999	1 550
-22	4.486	54 411	55	0.969	1 493
-21	4.458	51 341	56	0.941	1 439
-20	4.429	48 536	57	0.913	1 387
-19	4.399	45 819	58	0.887	1 337
-18	4.368	43 263	59	0.861	1 290
-17	4.336	40 858	60	0.835	1 244
-16	4.303	38 598	61	0.811	1 200
-15	4.269	36 476	62	0.787	1 158
-14	4.233	34 484	63	0.764	1 117
-13	4.196	32 613	64	0.741	1 079
-12	4.158	30 858	65	0.719	1 041
-11	4.119	29 211	66	0.698	1 006
-10	4.079	27 663	67	0.677	971
-9	4.037	26 208	68	0.657	938
-8	3.994	24 838	69	0.638	906
-7	3.951	23 545	70	0.619	876
-6	3.906	22 323	71	0.601	846
-5	3.861	21 163	72	0.583	818
-4	3.814	20 083	73	0.566	791
-3	3.765	19 062	74	0.549	765
-2	3.716	18 097	75	0.533	740
-1	3.667	17 185	76	0.518	715
0	3.617	16 325	77	0.503	692
1	3.565	15 513	78	0.488	670
2	3.512	14 747	79	0.474	648
3	3.459	14 023	80	0.460	628
4	3.406	13 341	81	0.447	608
5	3.353	12 696	82	0.434	588
6	3.298	12 087	83	0.422	570
7	3.242	11 510	84	0.410	552
8	3.185	10 963	85	0.398	535
9	3.129	10 444	86	0.387	518
10	3.074	9 949	87	0.376	502
11	3.016	9 486	88	0.365	487
12	2.959	9 046	89	0.355	472
13	2.901	8 628	90	0.344	458
14	2.844	8 232	91	0.335	444
15	2.788	7 855	92	0.325	431
16	2.730	7 499	93	0.316	418
17	2.672	7 160	94	0.308	405
18	2.615	6 839	95	0.299	393
19	2.559	6 535	96	0.291	382
20	2.503	6 246	97	0.283	371
21	2.447	5 972	98	0.275	360
22	2.391	5 711	99	0.267	349
23	2.335	5 463	100	0.260	339
24	2.280	5 226	101	0.253	330
25	2.227	5 000	102	0.246	320
26	2.173	4 787	103	0.239	311
27	2.120	4 583	104	0.233	302
28	2.067	4 389	105	0.227	294
29	2.015	4 204	106	0.221	286
30	1.965	4 028	107	0.215	278
31	1.914	3 861	108	0.210	270
32	1.865	3 701	109	0.205	262
33	1.816	3 549	110	0.198	255
34	1.768	3 404	111	0.193	248
35	1.721	3 266	112	0.188	242
36	1.675	3 134	113	0.183	235
37	1.629	3 008	114	0.178	229
38	1.585	2 888	115	0.174	223
39	1.542	2 773	116	0.170	217
40	1.499	2 663	117	0.165	211
41	1.457	2 559	118	0.161	205
42	1.417	2 459	119	0.157	200
43	1.377	2 363	120	0.153	195

Control Modules — Turn controller power off before servicing controls. This ensures safety and prevents damage to the controller.

The ICVC and CCM modules perform continuous diagnostic evaluations of the hardware to determine its condition. Proper operation of all modules is indicated by LEDs (light-emitting diodes) located on the circuit board of the ICVC and CCM.

There is one green LED located on the CCM board, and one red LED located on the ICVC and CCM boards.

RED LED (Labeled as STAT) — If the red LED:

- Blinks continuously at a 2-second interval — the module is operating properly
- Is lit continuously — there is a problem that requires replacing the module
- Is off continuously — the power should be checked
- Blinks 3 times per second — a software error has been discovered and the module must be replaced

If there is no input power, check the CB2 control power circuit breaker and control power transformer circuit breakers (CB1A and CB1B). If the breakers are good, check for a shorted 24 vac secondary of the T1 transformer or, if power is present to the module, replace the module.

GREEN LED (Labeled as COM) — These LEDs indicate the communication status between different parts of the controller and the network modules and should blink continuously.

Notes on Module Operation

1. The chiller operator monitors and modifies configurations in the microprocessor by using the 4 softkeys and the ICVC. Communications between the ICVC and the CCM is accomplished through the SIO (Sensor Input/Output) bus, which is a phone cable. The communication between the CCM and VFD is accomplished through a 3-wire SIO communication protocol cable.

2. If a green LED is on continuously, check the communication wiring. If a green LED is off, check the red LED operation. If the red LED is normal, check the SIO address switches (Fig. 62 and 63). Confirm all SW1 SIO address dip switches on the CCM are in the OFF position.

All system operating intelligence resides in the ICVC. Some safety shutdown logic resides in the VFD Gateway in case communications are lost between the VFD and ICVC. Outputs are controlled by the CCM and VFD Gateway as well.

3. In the control center, a 3 KVA transformer steps down line power to 115 V. This supplies power to the oil pump, oil vaporizer heater, oil sump heater, and control power transformers. Power is supplied to the ICVC and CCM modules within the control center via the T1 24-VAC transformer.

The control power transformers are located on the power panel.

Transformer T1 supplies 24 V power to the ICVC and CCM. Transformer T2 provides 20 V power to optional DataPort™ or DataLINK™ modules.

Power is connected to Plug J1 on the ICVC and CCM modules.

Chiller Control Module (CCM) (Fig. 63)

INPUTS — Each input channel has 2 or 3 terminals. Refer to individual chiller wiring diagrams for the correct terminal numbers for your application.

OUTPUTS — CCM terminals J11 and J12 are discrete (on/off) outputs that switch 24 volts. The 4 to 20 mA output channel on terminals J8-1 and J8-2 is designed for non-grounded controllers with a maximum input impedance of 500 ohms. J8-3 and J8-4 are used with a 500-ohm resistor to control the oil reclaim actuator.

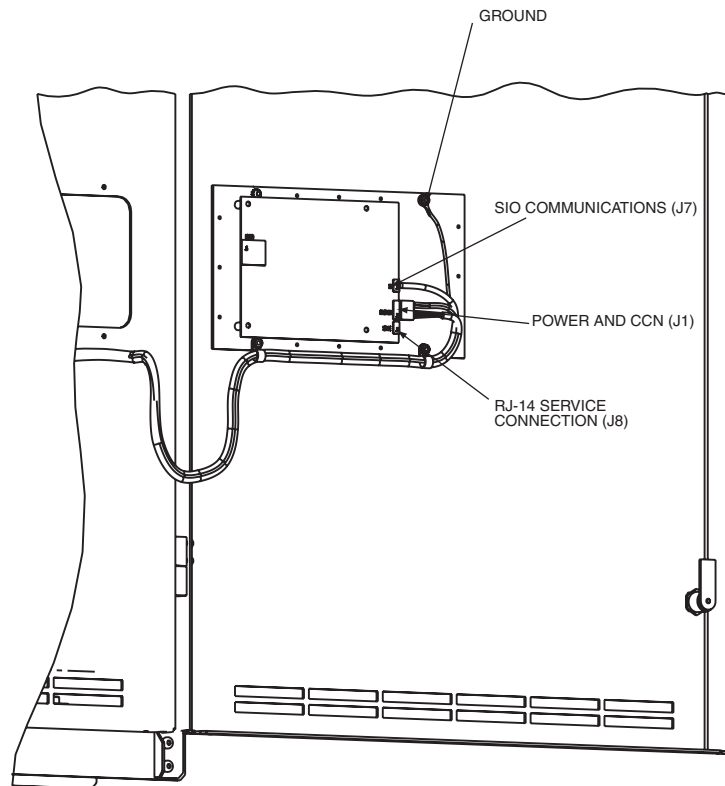

Fig. 62 — Rear of ICVC (International Chiller Visual Controller)

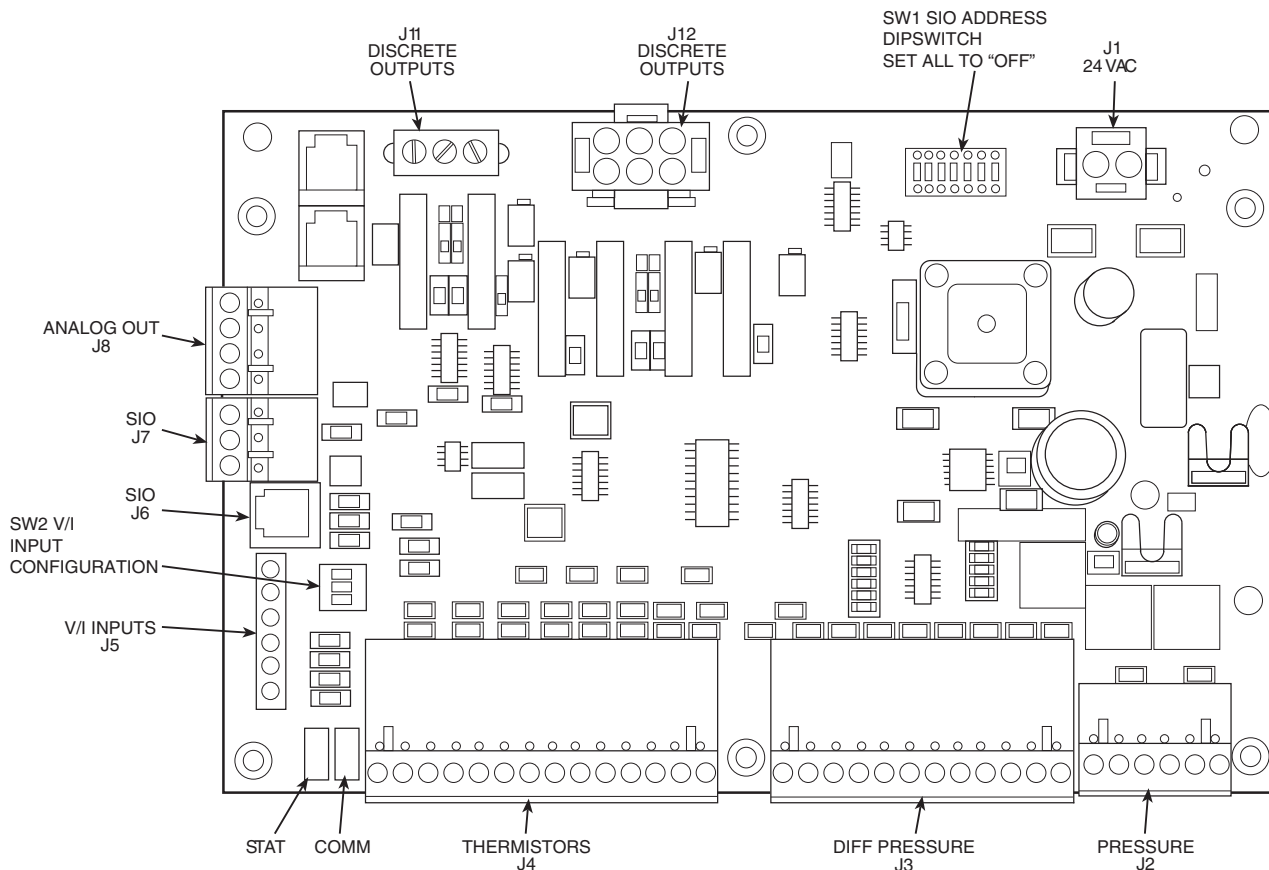

Fig. 63 — Chiller Control Module (CCM)

Replacing Defective ICVC Modules — The module replacement part number is printed on a small label on the rear of the ICVC module. The chiller model and serial numbers are printed on the chiller nameplate located on the right side of the control center. The proper software is factory-installed by Carrier in the replacement module. When ordering a replacement international chiller visual controller (ICVC) module, specify the complete replacement part number, full chiller model number, and chiller serial number. The installer must configure the new module to the original chiller data. Follow the procedures described in the Software Configuration section on page 75.

CAUTION

Electrical shock can cause personal injury. Disconnect all electrical power before servicing.

INSTALLATION

1. Verify the existing ICVC module is defective by using the procedure described in the Troubleshooting Guide section, page 100, and the Control Modules section on page 123. Do not select the ATTACH TO NETWORK DEVICE table if the ICVC indicates a CCN communication failure. Doing so will probably lock up the ICVC because it will not be able to communicate with the CCN.
2. Any communication wires from other chillers or CCN modules should be disconnected prior to installation of a new module to prevent the new ICVC from uploading incorrect run hours into memory. Data regarding the ICVC configuration should have been recorded and saved. This data must be reconfigured into the new ICVC. If this data is not available, follow the procedures described in the Software Configuration section. If the

module to be replaced is functional, configurations may also be copied manually. The data sheets on pages CL-4 through CL-10 are provided for this purpose. Default values are shown so that only deviations from these need to be recorded.

If a CCN Building Supervisor or Service Tool is available, the module configuration should have already been uploaded into memory. When the new module is installed, the configuration can be downloaded from the computer.

3. To install this module, record values for the *TOTAL COMPRESSOR STARTS*, *SERVICE ONTIME*, and the *COMPRESSOR ONTIME* from the MAINSTAT screen on the ICVC.
4. Power off the controls.
5. Remove the old ICVC.
6. Install the new ICVC module. Turn the control power back on.
7. The ICVC now automatically attaches to the local network device.
8. Set the current time and date in the SERVICE / TIME AND DATE screen. Set the CCN Bus and Address in the SERVICE / ICVC CONFIGURATION screen. Press the alarm RESET soft key (from the default screen). Upload via Service Tool or manually reenter all non-default configuration values. (Refer to pages CL-4 through CL-10.) If the correct *VFD_CONF* values are displayed when that table is viewed, simply press EXIT then SAVE to reload all of them. Using Service Tool or manually reenter *TOTAL COMPRESSOR STARTS*, *COMPRESSOR ONTIME*, and *SERVICE ONTIME*. If forced using Service Tool, release the force on *SERVICE ONTIME* after the desired value has been set. *TOTAL COMPRESSOR STARTS* and *TOTAL COMPRESSOR ONTIME* can

only be changed prior to the first completed start. If a start is completed and the *COMPRESSOR STARTS* or *COMPRESSOR ON TIME* are both incorrect, the ICVC software must be downloaded again before these settings can be changed.

9. Check and recalibrate pressure transducer readings (refer to page 99). Check that the CURRENT TIME and DATE in the TIME AND DATE screen are correct.

DPI Communications Interface Board Status LEDs — VFD status can be determined from the status LEDs on the DPI Communications Interface Board shown in Fig. 64. The DPI Board is mounted on the front of the VFD power module in a vertical orientation.

Gateway Status LEDs — The RS485 VFD Gateway provides a communication link between the CCM and ICVC SIO bus to the VFD Drive Peripheral Interface (DPI) board. The SIO bus communicates with the Gateway through VFD connector A32. See Fig. 65.

The Gateway has four status indicators on the top side of the module.

DRIVE STATUS INDICATOR — The DRIVE status indicator is on the right side of the Gateway. See Table 23.

Table 23 — Gateway DRIVE Status Indicator

STATE	CAUSE	CORRECTIVE ACTION
OFF	The Gateway is not powered or is not connected properly to the drive.	<ul style="list-style-type: none"> Securely connect the Gateway to the drive using the DPI ribbon cable. Apply power to the drive.
FLASHING RED	The Gateway is not receiving a ping message from the drive.	<ul style="list-style-type: none"> Verify that cables are securely connected. Cycle power to the drive.
SOLID RED	The drive has refused an I/O connection from the Gateway.	<p>IMPORTANT: Cycle power after making the following correction:</p> <ul style="list-style-type: none"> Verify that all DPI cables on the drive are securely connected and not damaged. Replace cables if necessary.
ORANGE	The Gateway is connected to a product that does not support Rockwell Automation DPI communications.	<ul style="list-style-type: none"> Check wires leading to the A32 terminal block. Check that A32 terminal block is fully engaged.
FLASHING GREEN	The Gateway is establishing an I/O connection to the drive or the I/O has been disabled.	Normal behavior.
SOLID GREEN	The Gateway is properly connected and is communicating with the drive.	No action required.

MS STATUS INDICATOR — The MS status indicator is the second LED from the right of the Gateway. See Table 24.

Table 24 — Gateway MS Status Indicator

STATE	CAUSE	CORRECTIVE ACTION
OFF	The Gateway is not powered.	<ul style="list-style-type: none"> Securely connect the Gateway to the drive using the ribbon cable. Apply power to the drive.
FLASHING RED	Recoverable Fault Condition	Cycle power to the drive. If cycling power does not correct the problem, the firmware may need to be flashed into the module.
SOLID RED	The module has failed the hardware test.	<ul style="list-style-type: none"> Cycle power to the drive Replace the Gateway
FLASHING GREEN	The Gateway is operational. No I/O data is being transferred.	Normal behavior during SIO configuration initialization process.
SOLID GREEN	The Gateway is operational and transferring I/O data.	No action required.

NET A STATUS INDICATOR — The NET A status indicator is the third LED from the right of the Gateway. See Table 25.

Table 25 — Gateway NET A Status Indicator

STATE	CAUSE	CORRECTIVE ACTION
OFF	The module is not powered or is not properly connected to the network. First incoming network command not yet recognized.	<ul style="list-style-type: none"> Securely connect the Gateway ribbon cable to the drive DPI board. Attach the RS485 cable in Gateway to the connector. Apply power to the drive.
FLASHING RED	Network has timed out.	Cycle power to the drive.
SOLID RED	The Gateway has detected an error that has made it incapable of communication on the network.	Check node address and data rate switch positions on the front of the Gateway. Cycle power to the drive.
FLASHING GREEN	Online to network, but not producing or consuming I/O information.	No action required. The LED will turn solid green when communication resumes.
SOLID GREEN	The module is properly connected and communicating on the network.	No action required.

NET B STATUS INDICATOR — The NET B status indicator is the left LED on the Gateway. See Table 26.

Table 26 — Gateway NET B Status Indicator

STATE	CAUSE	CORRECTIVE ACTION
OFF	Gateway not receiving data over the network.	<ul style="list-style-type: none"> Check wires leading to A32 terminal block. Check that A32 terminal block is fully engaged.
SOLID OR BLINKING GREEN	Gateway is transmitting data.	No action required.

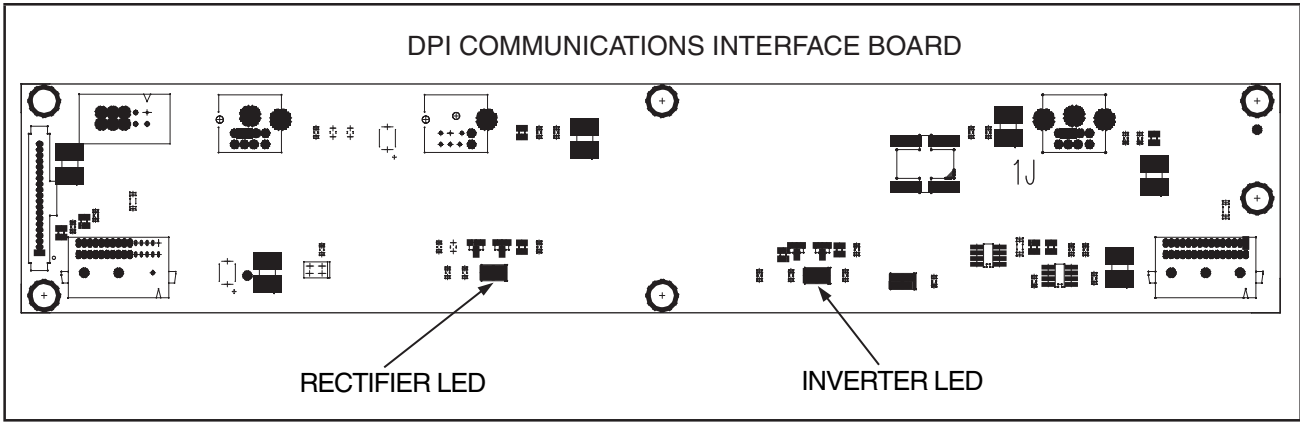

INVERTER STATUS LIGHT

COLOR	STATE	DESCRIPTION
GREEN	Flashing	Drive ready, but not running and no faults are present.
	Steady	Drive running, no faults are present.
YELLOW	Flashing	The drive is not ready. A VFD start inhibit is in effect. Normal condition when chiller not running because the ICVC has issued a stop command.
	Steady	An alarm condition exists. Check VFD FAULT CODE in ICVC VFD_STAT screen.
RED	Flashing	A fault has occurred. Check VFD FAULT CODE in ICVC VFD_STAT screen.
	Steady	A non-resettable fault has occurred. Check VFD FAULT CODE in ICVC VFD_STAT screen.
RED INVERTER GREEN RECTIFIER	Steady	VFD Gate Kill circuit has opened because the compressor high pressure switch has opened.

RECTIFIER STATUS LIGHT

COLOR	STATE	DESCRIPTION
GREEN	Flashing	Rectifier ready, but not running and no faults are present.
	Steady	Rectifier running, no faults are present.
YELLOW	Flashing	Rectifier is not ready. A VFD start inhibit is in effect. This is a normal state if the inverter is not running and/or the precharge contacts are open.
	Steady	Rectifier alarm condition exists. Check VFD FAULT CODE in ICVC VFD_STAT screen.
RED	Flashing	Rectifier fault has occurred. Check (VFD FAULT CODE in ICVC VFD_STAT screen.
	Steady	A non-resettable fault has occurred. Check VFD FAULT CODE in ICVC VFD_STAT screen.
RED INVERTER GREEN RECTIFIER	Steady	VFD Gate Kill circuit has opened because the compressor high pressure switch has opened.

INVERTER AND RECTIFIER CONTROL BOARD FAILURE STATUS LIGHT PATTERNS

COLOR	DESCRIPTION
RED/GREEN ALTERNATING	Control board application firmware may be corrupt. Call Carrier Service.
YELLOW/GREEN/RED REPEATING PATTERN	Control board RAM failure or control board firmware may be corrupt. Call Carrier Service.

Fig. 64 — DPI Communications Interface Board Status LEDs

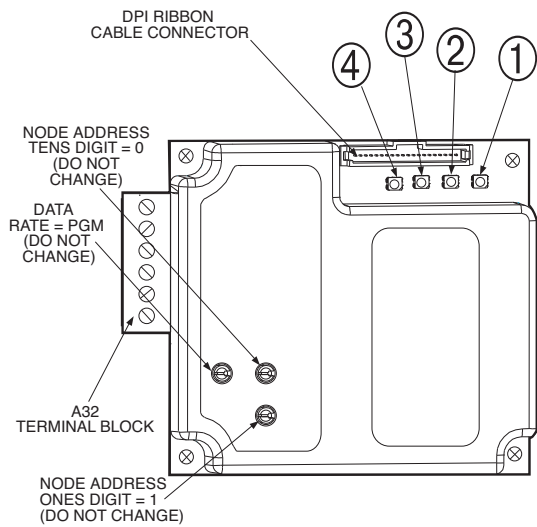

NUMBER	STATUS INDICATOR	DESCRIPTION
1	DRIVE	DPI Connection Status
2	MS	Module Status
3	NET A	Serial Communication Status
4	NET B	Serial Communication Traffic Status

NOTE: If all status indicators are off, the Gateway is not receiving power.

Fig. 65 — Gateway Status LEDs

PD4 EXV BOARD (P Compressor Only) — See Fig. 66. The PD4 EXV board communicates with the master CCM board through an RS-485 port. It provides input/output for both the main condenser EXV and optional economizer EXV, as well as the economizer gas temperature. Dip switch settings are shown in Fig. 66.

During communication a green activity LED will be displayed, and a red LED will blink during normal operation at a 1-second-on, one-second-off frequency (0.5 Hz).

PD4 AUX1 BOARD (P Compressor Only) — See Fig. 67. The AUX1 board communicates through RS-485 (J9) with the PD4 EXV board and the master CCM board. It provides input/output for the condenser liquid sensor. Dip switch settings are shown in Fig. 67.

The red LED indicates the AUX1 board status as follows:

RED LED CONDITION	AUX BOARD SOFTWARE STATUS
Off continuously	Board unpowered or power supply defective
On continuously	Board is powered but board microcontroller is inactive or defective
Flashing (1 second on, 1 second off, 0.5 Hz)	Board is operating with correct board microcontroller operation
Flashing at any other frequency	Board is operating defectively

The green LED lights every time the AUX board transmits a message, so the frequency of the green LED is consistent with the frequency of transmitted messages.

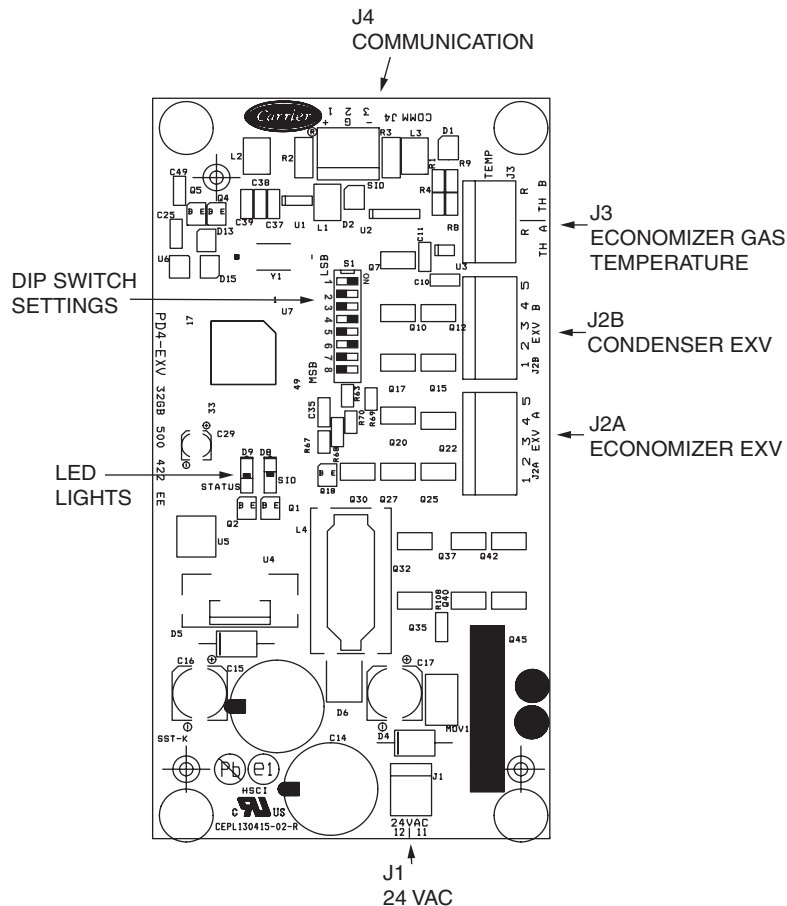

Fig. 66 — PD4 EXV Board (P Compressor Only)

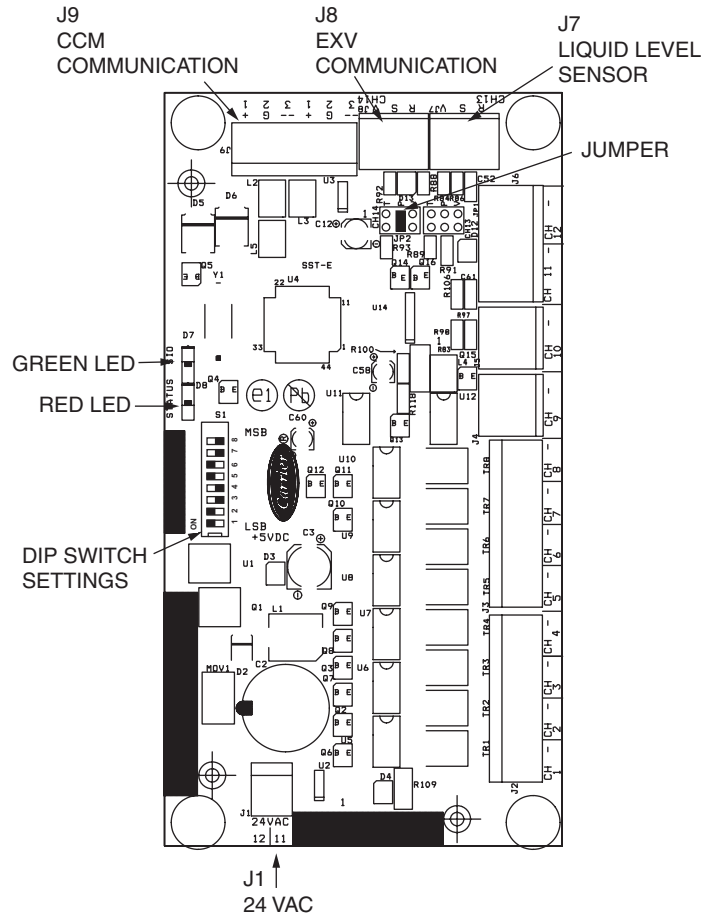

Fig. 67 — PD4 AUX1 Board (P Compressor Only)

EXV TROUBLESHOOTING — If it appears that the main EXV or economizer EXV is not properly controlled, perform the following checks. Through Controls Test move the EXV fully open. The actuator should be felt through the EXV body. Then close the valve fully. The actuator should knock when it reaches the bottom of its stroke.

If the valve is not operating properly, continue checking the PD4 EXV DIP switch settings (Fig. 66). Check the EXV output signals at J2A and J2B respectively on the EXV module. Connect positive test lead to J2A or J2B (as appropriate) terminal 5 and move the valve output using the Controls Test to 100%, while being careful not to short any pins as board damage will occur. During the next several seconds (while moving the actuator) carefully connect the negative test to pins 1, 2, 3 and 4 in succession. The digital voltmeter will average this signal and display approximately 6 vdc. If the output remains at a constant voltage other than 6 vdc or shows 0 volts, remove the connector to the valve and recheck. If confirmed, this may indicate a bad EXV board. Note that 12 vdc is the output from the EXV board when the valve is stationary.

If the reading is correct, the expansion valve and EXV wiring should be checked. Check the EXV connector and interconnecting wiring by double checking color-coding and make sure that all are connected to the correct terminals and that wires are not crossed. Check for continuity and tight connections at all pin terminals.

Disassembling and Assembling the EXV — Disassemble the EXV to check EXV motor windings and the condenser liquid level sensor. When disassembling the EXV, always have a

new o-ring available. Do not use the existing o-ring. Place the piston in the fully open position to disassembly the EXV. When assembling the VFD, it is easier to install the motor assembly with the piston in the fully closed position. See Fig. 23 for EXV cross-section diagrams. See Figs. 68 and 69 for disassembly and assembly instructions.

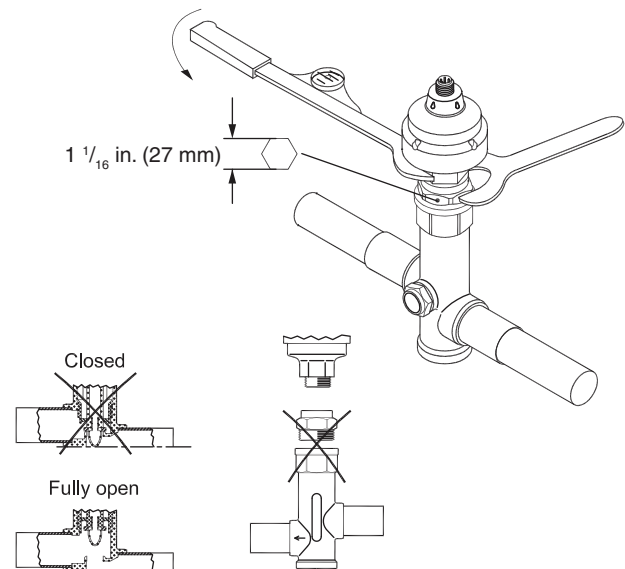

Fig. 68 — EXV Disassembly

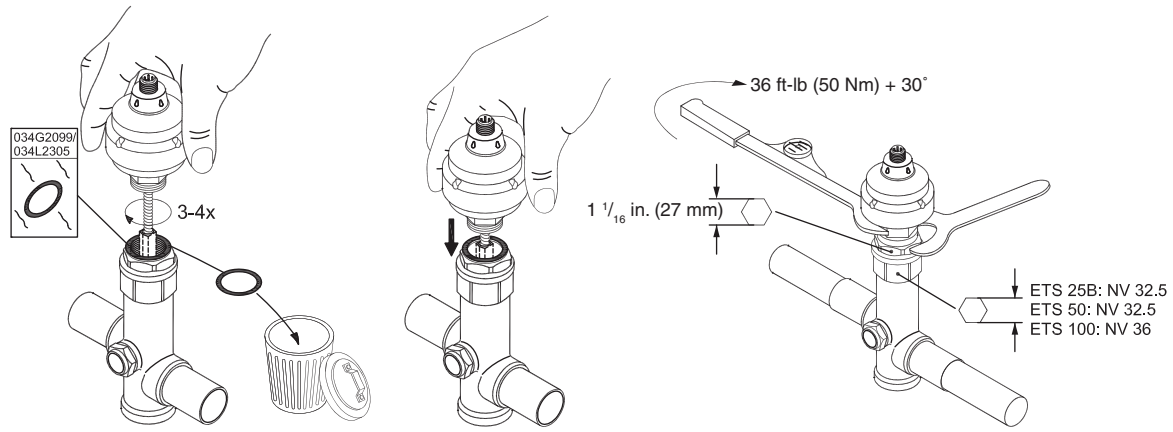

Fig. 69 — EXV Assembly

Check EXV Motor Windings Resistance — To check the resistance of the EXV motor windings, remove the EXV plug at J2A (economizer EXV) or J2B (condenser EXV) and check resistance. The resistance should be 52 ohms ($\pm 10\%$). See Fig. 70.

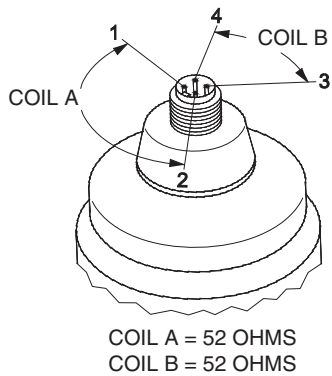

Fig. 70 — EXV Motor Windings Resistance

Check Condenser Level Sensor Resistance — The level sensor provides a voltage between white (output) and black (ground) wires proportional to red (+) and black (ground) voltage. If the level sensor is suspected of misreading, check the resistance between red (+) and black (ground) wires. It should measure approximately 1800 ohms. Figure 71 shows condenser liquid level sensor components.

CAUTION

Do not attempt to disconnect flanges while the machine is under pressure. Failure to relieve pressure can result in personal injury or damage to the unit.

CAUTION

Before rigging the compressor, disconnect all wires entering the power panel to avoid damage to the panel.

End of Life and Equipment Disposal — This equipment has an average design life span of 25 years and is constructed primarily of steel and copper. Content of control panels includes, but is not limited to, common electrical components such as fuses, circuit breakers, wire, and printed circuit boards.

Prior to retiring of equipment, it will be necessary to remove all fluids such as water, refrigerant, and oil using the current industry guidelines for recovery and disposal.

Physical Data — Tables 27-40 and Fig. 72-83 provide additional information on component weights, physical and electrical data, and wiring schematics for the operator's convenience during troubleshooting.

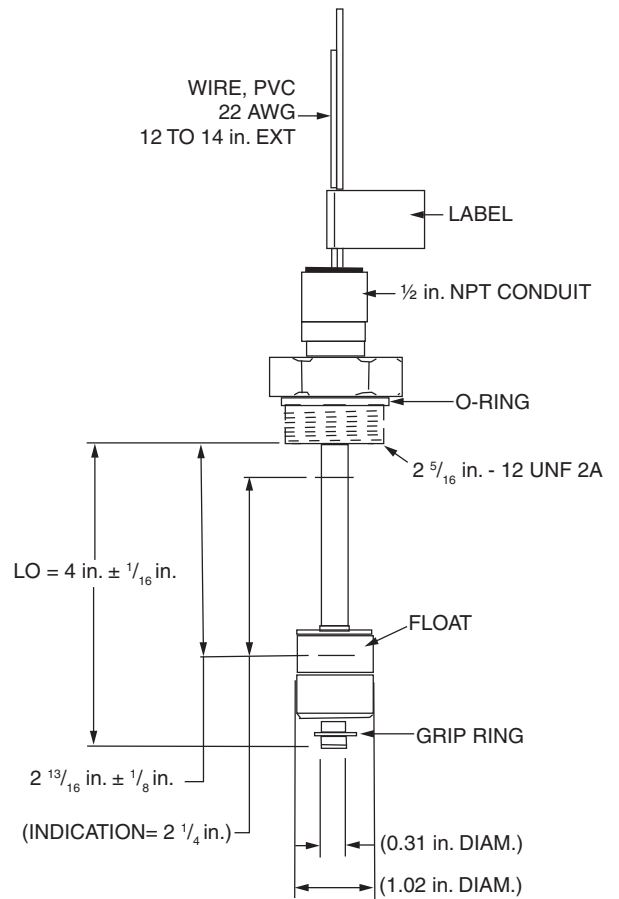

Fig. 71 — Condenser

Table 27 — 23XRV Cooler Frame Size A1-A6, B1-B6 Heat Exchanger Weights

FRAME SIZE	ENGLISH							METRIC (SI)						
	STEEL WT (lb)	COPPER WT (lb)	DRY RIGGING WT* (lb)	REFRIG. WT (lb)	SHIP WT (lb)	WATER VOL (Gal)	OPER. WT (lb)	STEEL WT (kg)	COPPER WT (kg)	DRY RIGGING WT* (kg)	REFRIG. WT (kg)	SHIP WT (kg)	WATER VOL (L)	OPER. WT (kg)
A1	2506	734	3240	270	3510	47	3904	1137	333	1470	122	1592	178	1771
A2	2506	789	3295	290	3585	51	4009	1137	358	1495	132	1627	193	1819
A3	2506	889	3395	310	3705	57	4182	1137	403	1540	141	1681	216	1897
A4	2506	962	3468	330	3798	62	4315	1137	436	1573	150	1723	235	1958
A5	2506	1076	3582	360	3942	69	4520	1137	488	1625	163	1788	261	2050
A6	2506	1190	3696	390	4086	77	4725	1137	540	1677	177	1854	291	2144
B1	2642	839	3481	305	3786	54	4236	1198	381	1579	138	1717	204	1921
B2	2642	901	3543	325	3868	58	4352	1198	409	1607	147	1754	220	1974
B3	2642	1016	3658	355	4013	65	4558	1198	461	1659	161	1820	246	2067
B4	2642	1099	3741	375	4116	71	4706	1198	498	1696	170	1866	269	2134
B5	2642	1229	3871	415	4286	79	4946	1198	557	1755	188	1943	299	2242
B6	2642	1360	4002	445	4447	87	5177	1198	617	1815	202	2017	329	2348

*Dry rigging weight = Steel weight + Copper weight.

Table 28 — 23XRV Condenser Frame Size A1-A6, B1-B6 Heat Exchanger Weights

FRAME SIZE	ENGLISH							METRIC (SI)						
	STEEL WT (lb)	COPPER WT (lb)	DRY RIGGING WT* (lb)	REFRIG. WT (lb)	SHIP WT (lb)	WATER VOL (Gal)	OPER. WT (lb)	STEEL WT (kg)	COPPER WT (kg)	DRY RIGGING WT* (kg)	REFRIG. WT (kg)	SHIP WT (kg)	WATER VOL (L)	OPER. WT (kg)
A1	3390	734	4124	550	4674	47	5068	1538	333	1871	249	2120	178	2299
A2	3390	844	4234	550	4784	54	5237	1538	383	1921	249	2170	204	2375
A3	3390	944	4334	550	4884	61	5391	1538	428	1966	249	2215	231	2445
A4	3390	1049	4439	550	4989	67	5552	1538	476	2014	249	2263	254	2518
A5	3390	1190	4580	550	5130	77	5769	1538	540	2078	249	2327	291	2617
A6	3390	1345	4735	550	5285	87	6007	1538	610	2148	249	2397	329	2724
B1	3571	839	4410	625	5035	54	5485	1620	381	2001	283	2284	204	2488
B2	3571	964	4535	625	5160	62	5677	1620	437	2057	283	2340	235	2575
B3	3571	1078	4649	625	5274	69	5853	1620	489	2109	283	2392	261	2655
B4	3571	1198	4769	625	5394	77	6037	1620	543	2163	283	2446	291	2738
B5	3571	1360	4931	625	5556	87	6286	1620	617	2237	283	2520	329	2851
B6	3571	1537	5108	625	5733	99	6558	1620	697	2317	283	2600	375	2974

*Dry rigging weight = Steel weight + Copper weight.

Table 29 — 23XRV Code 30-57 Heat Exchanger Weights

CODE	ENGLISH							SI						
	DRY RIGGING WEIGHT (lb)*		MACHINE CHARGE				DRY RIGGING WEIGHT (kg)*		MACHINE CHARGE					
	COOLER ONLY	CONDENSER ONLY	REFRIGERANT WEIGHT (lb)		LIQUID VOLUME (Gal)		COOLER ONLY	CONDENSER ONLY	REFRIGERANT WEIGHT (kg)		LIQUID VOLUME (L)			
			WITH ECONOMIZER	WITHOUT ECONOMIZER	COOLER	CONDENSER			WITH ECONOMIZER	WITHOUT ECONOMIZER	COOLER	CONDENSER		
30	4148	3617	800	650	56	56	1877	1676	363	295	212	212		
31	4330	3818	800	650	64	65	1959	1769	363	295	242	246		
32	4522	4023	800	650	72	74	2046	1860	363	295	273	280		
35	4419	4529	910	760	61	61	2000	2089	413	345	231	231		
36	4627	4758	910	760	70	72	2094	2195	413	345	265	273		
37	4845	4992	910	760	80	83	2193	2299	413	345	303	314		
40	5008	4962	900	750	103	110	2675	2746	408	340	390	416		
41	5178	5155	900	750	111	119	2758	2839	408	340	420	450		
42	5326	5347	900	750	119	129	2832	2932	408	340	450	488		
45	5463	5525	1015	865	112	120	2882	3001	460	392	424	454		
46	5659	5747	1015	865	122	130	2976	3108	460	392	462	492		
47	5830	5967	1015	865	130	141	3061	3214	460	392	492	534		
50	5827	6013	1250	1100	132	147	3182	3304	567	499	500	556		
51	6053	6206	1250	1100	143	156	3294	3397	567	499	541	590		
52	6196	6387	1250	1100	150	165	3364	3485	567	499	568	625		
55	6370	6708	1430	1280	144	160	3429	3620	649	581	545	606		
56	6631	6930	1430	1280	156	171	3556	3726	649	581	590	647		
57	6795	7138	1430	1280	164	181	3636	3826	649	581	621	685		

*Rigging weights are for standard tubes of standard wall thickness (Turbo-B3 and Spikefin 2, 0.025-in. [0.635 mm] wall).

NOTES:

1. Cooler includes the suction elbow and 1/2 the distribution piping weight.

2. Condenser includes float valve and sump, discharge stub-out, and 1/2 the distribution piping weight.

3. For special tubes refer to the 23XRV Computer Selection Program.

4. All weights for standard 2-pass NIH (nozzle-in-head) design with Victaulic grooves.

Table 30 — 23XRV Compressor and Motor Weights

COMPRESSOR TYPE	MOTOR SIZE	ENGLISH				SI			
		TOTAL COMPRESSOR WEIGHT (lb)	STATOR WEIGHT (lb)	ROTOR WEIGHT (lb)	MOTOR TERMINAL COVER (lb)	TOTAL COMPRESSOR WEIGHT (kg)	STATOR WEIGHT (kg)	ROTOR WEIGHT (kg)	MOTOR TERMINAL COVER (kg)
P	H,J	3036	110	167	N/A	1377	50	76	N/A
Q	V	4090	370	193	39	1855	168	88	18
R	P,Q,R,S,T,U,V,X	4866	441	229	46	2207	200	104	21

Table 31 — 23XRV Maximum Component Weights*

COMPONENT		FRAME A HEAT EXCHANGER		FRAME B HEAT EXCHANGER		FRAME 3 HEAT EXCHANGER		FRAME 4 HEAT EXCHANGER		FRAME 5 HEAT EXCHANGER	
		lb	kg	lb	kg	lb	kg	lb	kg	lb	kg
Isolation Valves		70	32	70	32	115	52	70	32	70	32
Suction Elbow	P Compressor	N/A	N/A	N/A	N/A	N/A	N/A	N/A	N/A	N/A	N/A
	Q Compressor	159	72	187	85	184	83	N/A	N/A	N/A	N/A
	R Compressor	179	81	237	108	232	105	N/A	N/A	N/A	N/A
Discharge Elbow/ Muffler	P Compressor	N/A	N/A	N/A	N/A	N/A	N/A	584	265	584	265
	Q Compressor	597	271	597	271	597	271	N/A	N/A	N/A	N/A
	R Compressor	747	339	747	339	747	339	N/A	N/A	N/A	N/A
Vaporizer and Oil Sump		700	318	700	318	700	318	700	318	700	318
Economizer		542	246	542	246	542	246	174	79	174	79

*To determine compressor frame size, refer to Fig. 1.

Table 32 — VFD (Variable Frequency Drive) Weight Table

DRIVE TYPE	COMPRESSOR	VOLTAGE/Hz	AMPERAGE (A)	WEIGHT (lb)
Std. Tier	P	380/400/415/50 and 480/60	230	998
			335, 445	1200
		575/60	269	1200
	Q/R	380/400/415/50 and 480/60	230	998
			335, 445	1200
		575/60	389, 469	1650
LF2	Q/R	380-415 50/60	440	1400
			520, 608	1800
		440-480 50/60	440	1500
			520, 608	1800

Table 33 — 23XRV Waterbox Cover Weights, Frames 3,4,5 — English (lb)

WATERBOX DESCRIPTION	COOLER						CONDENSER					
	FRAME 3		FRAME 4		FRAME 5		FRAME 3		FRAME 4		FRAME 5	
	VICTAULIC NOZZLES	FLANGED	VICTAULIC NOZZLES	FLANGED	VICTAULIC NOZZLES	FLANGED	VICTAULIC NOZZLES	FLANGED	VICTAULIC NOZZLES	FLANGED	VICTAULIC NOZZLES	FLANGED
NIH 1 Pass Cover, 150 psig	282	318	148	185	168	229	282	318	148	185	168	229
NIH 2 Pass Cover, 150 psig	287	340	202	256	222	276	287	340	191	245	224	298
NIH 3 Pass Cover, 150 psig	294	310	472	488	617	634	294	310	503	519	628	655
NIH Plain End, 150 psig	243	243	138	138	154	154	225	225	138	138	154	154
MWB End Cover, 150 psig*	243/315	243/315	138/314	138/314	154/390	154/390	225/234	225/234	138/314	138/314	154/390	154/390
NIH 1 Pass Cover, 300 psig	411	486	633	709	764	840	411	486	633	709	764	840
NIH 2 Pass Cover, 300 psig	411	518	626	733	760	867	411	578	622	729	727	878
NIH 3 Pass Cover, 300 psig	433	468	660	694	795	830	433	468	655	689	785	838
NIH Plain End, 300 psig	291	291	522	522	658	658	270	270	522	522	658	658
MWB End Cover, 300 psig*	445/619	445/619	522/522	522/522	658/658	658/658	359/474	359/474	522/522	522/522	658/658	658/658

LEGEND

NIH —Nozzle-in-Head
MWB —Marine Waterbox

NOTE: Weight for NIH 2-pass cover, 150 psig (1034 kPa), is included in the heat exchanger weights shown in Tables 27-29.

*Rows with two entries list nozzle end and return end weights.

Table 34 — 23XRV Waterbox Cover Weights, Frames 3,4,5 — SI (kg)

WATERBOX DESCRIPTION	COOLER						CONDENSER					
	FRAME 3		FRAME 4		FRAME 5		FRAME 3		FRAME 4		FRAME 5	
	VICTAULIC NOZZLES	FLANGED	VICTAULIC NOZZLES	FLANGED	VICTAULIC NOZZLES	FLANGED	VICTAULIC NOZZLES	FLANGED	VICTAULIC NOZZLES	FLANGED	VICTAULIC NOZZLES	FLANGED
NIH 1 Pass Cover, 1034 kPa	128	144	67	84	76	104	128	144	67	84	76	104
NIH 2 Pass Cover, 1034 kPa	130	154	92	116	101	125	130	154	87	111	102	135
NIH 3 Pass Cover, 1034 kPa	133	141	214	221	280	288	133	141	228	235	285	297
NIH Plain End, 1034 kPa	110	110	63	63	70	70	102	102	63	63	70	70
MWB End Cover 1034 kPa*	110/143	110/143	63/142	63/142	70/177	70/177	102/106	102/106	63/142	63/142	70/177	70/177
NIH 1 Pass Cover, 2068 kPa	186	220	287	322	347	381	186	220	287	322	346	381
NIH 2 Pass Cover, 2068 kPa	186	235	284	332	344	393	186	235	282	331	330	398
NIH 3 Pass Cover, 2068 kPa	196	212	299	315	361	376	196	212	297	313	356	380
NIH Plain End 2068 kPa	132	132	237	237	298	298	122	122	237	237	298	298
MWB End Cover 2068 kPa*	202/281	202/281	237/237	237/237	298/298	298/298	163/215	163/215	237/237	237/237	298/298	298/298

LEGEND

*Rows with two entries list nozzle end and return end weights.

NIH — Nozzle-in-Head
MWB — Marine Waterbox

NOTE: Weight for NIH 2-pass cover, 150 psig (1034 kPa), is included in the heat exchanger weights shown in Tables 27-29.

Table 35 — 23XRV Waterbox Cover Weights, Frames A/B — English (lb)

WATERBOX DESCRIPTION	COOLER FRAMES A AND B		CONDENSER FRAMES A AND B	
	VICTAULIC NOZZLES	FLANGED	VICTAULIC NOZZLES	FLANGED
NIH,1-Pass Cover 150 psig	217	244	242	274
NIH,2-Pass Cover 150 psig	172	265	191	298
NIH,3-Pass Cover 150 psig	228	245	261	277
NIH/Marine Plain End, 150 psig	157	157	173	173
MWB Cover, 150 psig	296	296	332	332
NIH,1-Pass Cover 300 psig	217	271	242	312
NIH,2-Pass Cover 300 psig	172	301	191	334
NIH,3-Pass Cover 300 psig	228	263	261	295
NIH/Marine Plain End, 300 psig	157	157	173	173
MWB Cover, 300 psig	296	296	332	332

LEGEND

NOTE: Weight for NIH 2-pass cover, 150 psig (1034 kPa), is included in the heat exchanger weights shown in Tables 27-29.

NIH — Nozzle-in-Head
MWB — Marine Waterbox

Table 36 — 23XRV Waterbox Cover Weights, Frames A/B — SI (kg)

WATERBOX DESCRIPTION	COOLER FRAMES A AND B		CONDENSER FRAMES A AND B	
	VICTAULIC NOZZLES	FLANGED	VICTAULIC NOZZLES	FLANGED
NIH,1-Pass Cover 1034 kPa	98	111	110	124
NIH,2-Pass Cover 1034 kPa	78	120	87	135
NIH,3-Pass Cover 1034 kPa	103	111	118	126
NIH/Marine Plain End, 1034 kPa	71	71	78	78
MWB Cover, 1034 kPa	134	134	151	151
NIH,1-Pass Cover 2068 kPa	98	123	110	142
NIH,2-Pass Cover 2068 kPa	78	137	87	151
NIH,3-Pass Cover 2068 kPa	103	119	118	134
NIH/Marine Plain End, 2068 kPa	71	71	78	78
MWB Cover, 2068 kPa	134	134	151	151

LEGEND

NOTE: Weight for NIH 2-pass cover, 150 psig (1034 kPa), is included in the heat exchanger weights shown in Tables 27-29.

NIH — Nozzle-in-Head
MWB — Marine Waterbox

Table 37 — Optional Storage Tank and/or Pumpout System Physical Data

UNIT SIZE	TANK OUTSIDE DIAMETER		DRY WEIGHT		MAXIMUM REFRIGERANT CAPACITY			
					ASHRAE/ANSI 15		UL-1963	
	in.	mm	lb	kg	HFC-134A		HFC-134A	
					lb	kg	lb	kg
28	24.00	610	2334	1059	1860	844	1716	778
52	27.25	692	3414	1549	3563	1616	3286	1491

LEGEND

ANSI — American National Standards Institute
 ASHRAE — American Society of Heating, Refrigerating, and Air-Conditioning Engineers
 UL — Underwriters Laboratories

NOTES:

1. ANSI/ASHRAE 15 — Safety Code for Mechanical Refrigeration
 2. Dry weights include the pumpout condensing unit weight of 164 lb (75 kg).

Table 38 — Optional Storage Tank and/or Pumpout System Electrical Data

VOLTS-PH-HZ	MAX RLA	LRA
208/230-3-50/60	15.8	105.0
460-3-60	7.8	52.0
400-3-50	7.8	52.0

LEGEND

LRA — Locked Rotor Amps
 RLA — Rated Load Amps

Table 39 — 23XRV Compressor Torque Specification Chart

LOCATION/USAGE	DESCRIPTION	PART NO.	TORQUE	
			LB-FT	NM
Hermetic Term, Outlet Casing Sub-Assembly Motor Side Seal Installation	M5 X 0.8 X 16LG SHCS GR 12.9	8TR0115	5-7	7-9
Inlet Seal Installation	M5 X 0.8 X 30LG SHCS GR 12.9	8TR0116	5-7	7-9
	M5 X 0.8 X 60LG SHCS GR 12.9	8TR0117	5-7	7-9
Bearing Cover Installation	M10 X 1.5 X 40LG SHCS GR 12.9	8TR0303	50-55	68-75
Outlet Casing Process Bolts	M20 X 1.0 X 120LG SHCS GR 12.9	8TR0304	430-450	583-610
Motor Terminal Cover Install and Lube Block	M12 X 1.75 X 50LG SHCS GR 12.9	8TR0120	90- 95	122-129
Motor Housing and Bearing Cover Installation	M20 X 2.5 X 80LG SHCS GR 12.9	8TR0122	430-450	583-610
Discharge Flange	M20 X 2.5 X 310LG HHCS GR 12.9	8TR0381	430-450	583-610
Motor Stator Sub-Assembly	Set Screw M10 X 1.5 X 30	8TC0089C	30-35	41-47
Bearing Cover Lube Plug	1/4" NPTF	8TC0290C	20-25	27-34
Rotor Caps and Male Axial Seal	M6 X 1.0 X 25LG SHCS GR 12.9	8TQ0189	7-9	9-12
Plug Installation	3/8" SAE (9/16 Thread)	8TC0107C	17-9	23-26
	3/8" SAE (9/16 Thread)	8TR0106	17-9	23-26
Rotor Housing	3/4" SAE (11/16 Thread)	8TC0109C	83-92	112-125
Motor Housing Air Gap Check	7/8" SAE (13/16 Thread)	8TR0128	92-103	125-140
Motor Installation	13/16", Terminal Pin Body	HY85AA062	45-55	61-75
	5/8", Term Nut, Mtr Lead, Term Nut	HY85AA062	40-45	54-61
Motor Rotor (Special)	M16 X 2 X 70LG HHCS GR 10.9	8TR0121	17-22	23-30
Lube Cover Plate Installation Valve Pad Installation	M12 X 1.75 X 30LG SHCS GR 12.9	8TC1044	87-93	118-126
Economizer Cover	5/8" — 11UNC X 1.88" LG HHCS GR 8	8TR0238	185-195	251-264
Lube Block and Bearing Cover Plate	1/8" — 27 NPT (Brass) Orifice	8TR0357	4-6	5-8
Lube Block	3/8" SAE (9/16 Thread) Choke Orifice	8TR0358	17-19	23-26
Suction and Discharge Covers	7/8" — 9 UNC X 2" LG HHCS GR 8	8TR0363	430-450	583-610
Terminal Pins	M5 X 0.8 X 24LG SHCS GR 12.9	8TR0395	5-7	7-9
	M20 X 2.5 X 247LG HHCS GR 12.9	ITQ0406	430-450	583-610
Discharge Cover	M20 X 2.5 X 260LG HHCS GR 12.9	ITQ0045	430-450	583-610
	1" — 8UNC X 3" LG HHCS GR 5	AA06BR419	430-450	583-610
Economizer Shipping Plate	M12 X 1.75 X 35LG HHCS	8TB0396	90-110	122-149
	O-Ring Plug (7/16-20 Thread)	05GA501762	10-12	14-16

LEGEND

GR — Grade
 HHCS — Hex Head Cap Screw
 LG — Long
 SAE — Society of Automotive Engineers
 SHCS — Socket Head Cap Screw
 UNC — Unified Coarse Thread

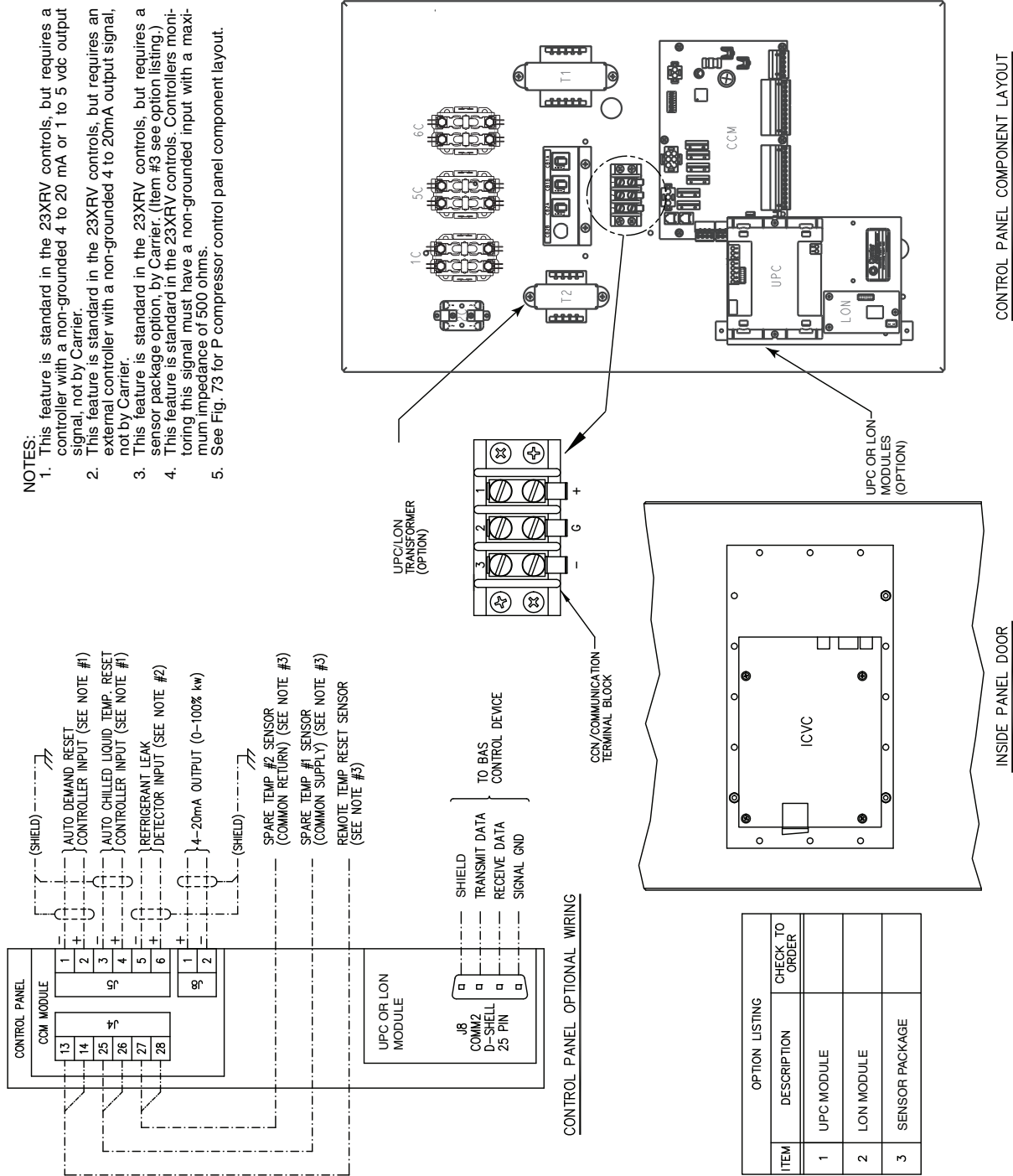

Fig. 72 — 23XRV Controls Layout (Q,R Compressors)

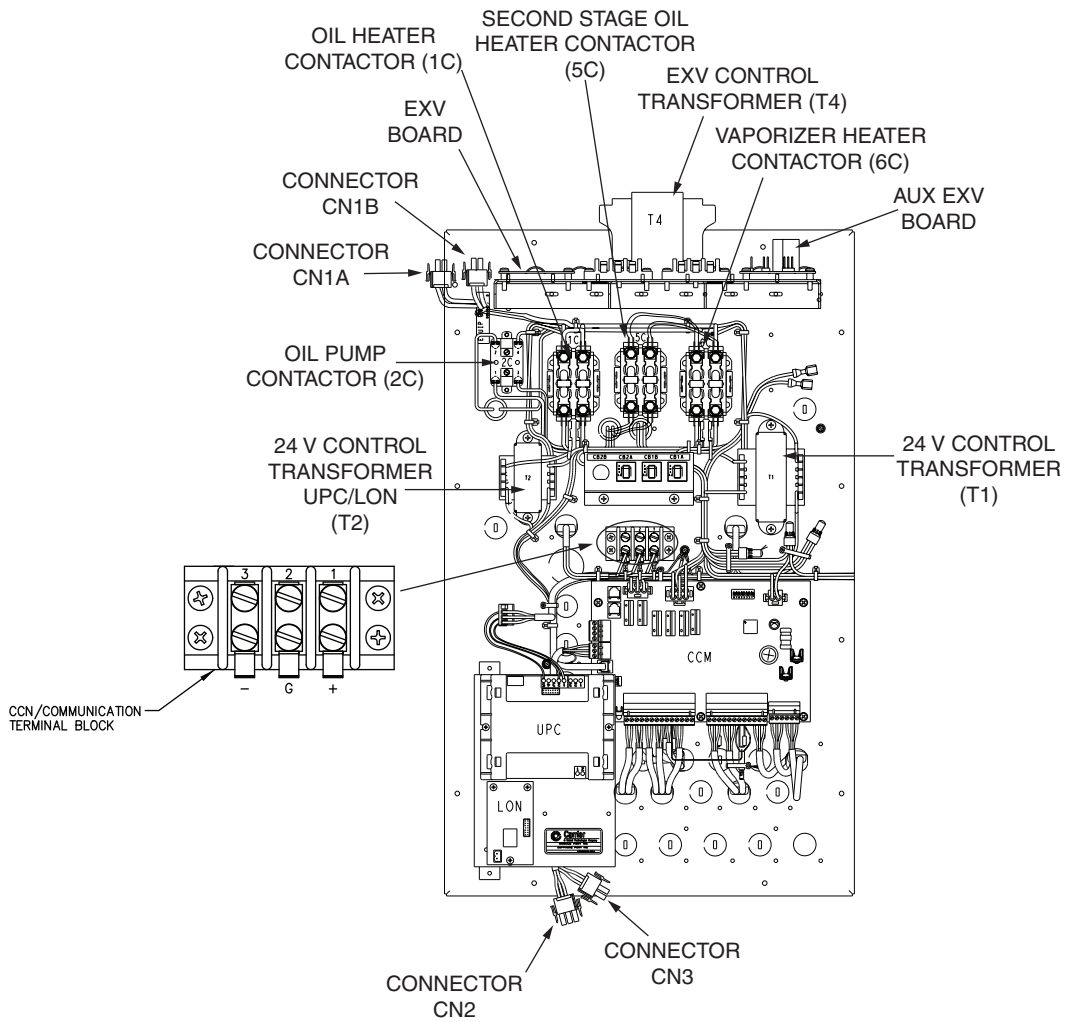
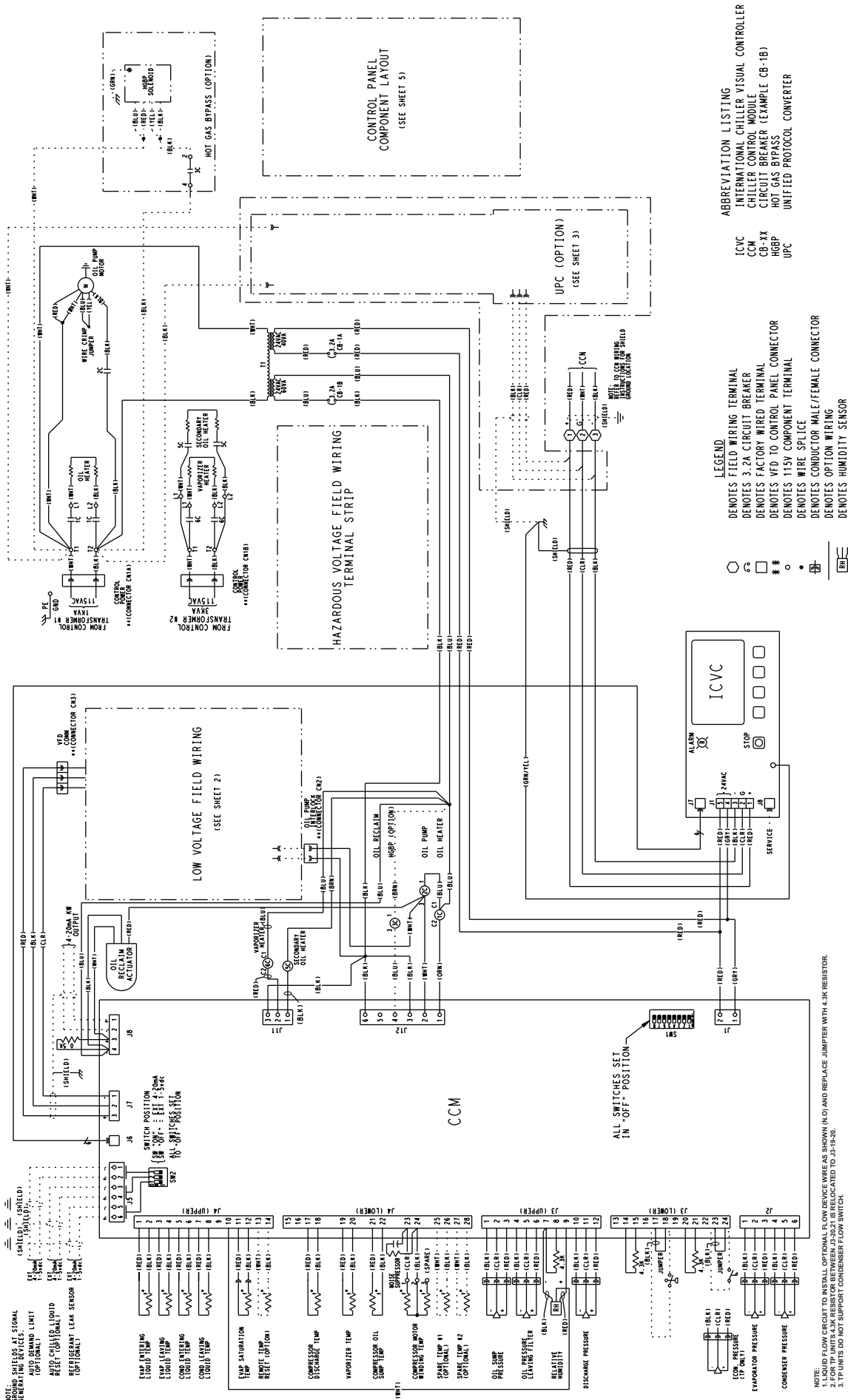
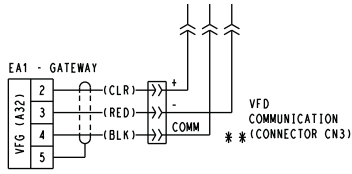

Fig. 73 — PIC III Control Component Layout (P Compressor Units)



→ Fig. 74 — 23XRV Controls Schematic

GATEWAY COMMUNICATION CARD



UPC OPTION P COMPRESSOR ONLY

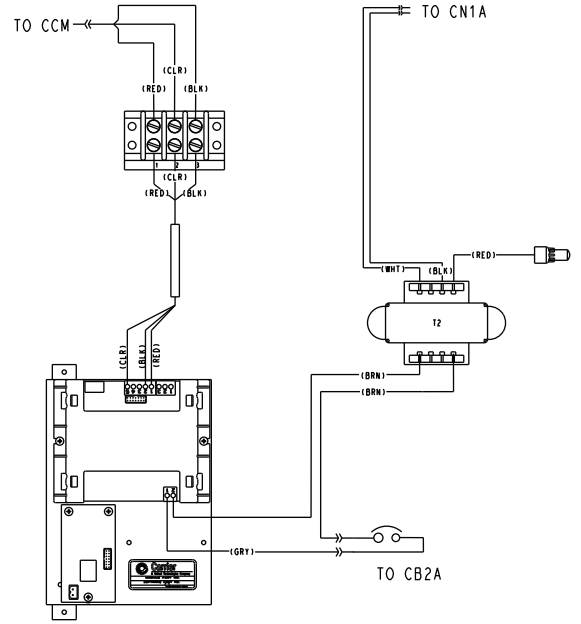

HAZARDOUS VOLTAGE WIRING

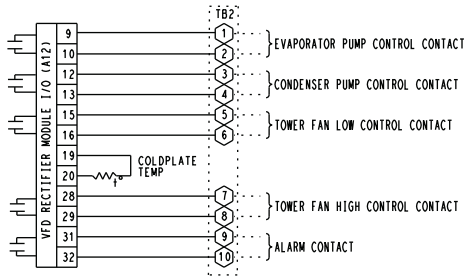

LOW VOLTAGE FIELD WIRING

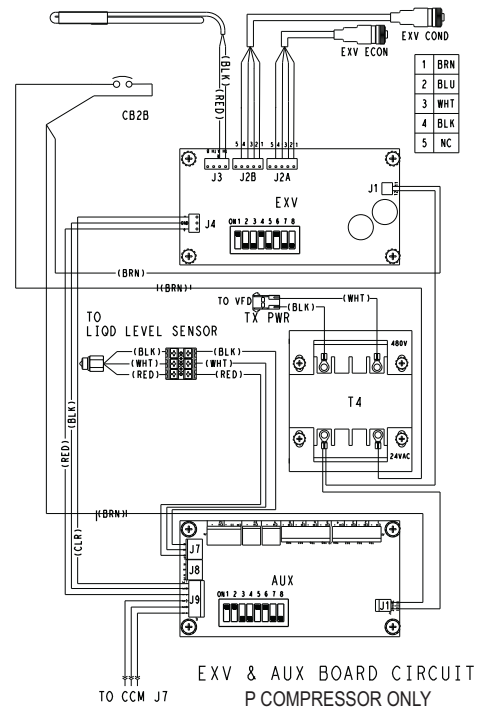
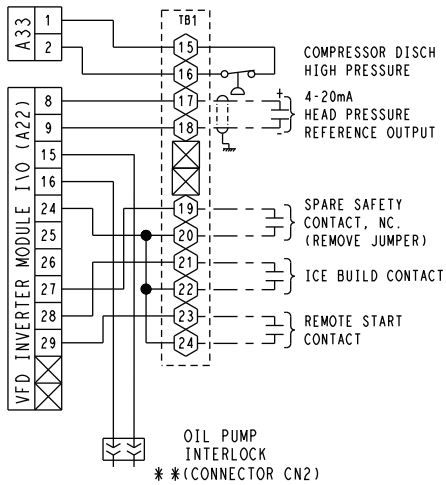

- LEGEND**
- DENOTES FIELD WIRING TERMINAL
 - DENOTES 3.2A CIRCUIT BREAKER
 - DENOTES FACTORY WIRED TERMINAL
 - *** DENOTES VFD TO CONTROL PANEL CONNECTOR
 - DENOTES 115V COMPONENT TERMINAL
 - DENOTES WIRE SPLICE
 - ⊕ DENOTES CONDUCTOR MALE/FEMALE CONNECTOR
 - ⊖ DENOTES OPTION WIRING
 - ⊗ DENOTES HUMIDITY SENSOR

- ABBREVIATION LISTING**
- AXX VFD TERMINAL BOARD (EXAMPLE A12)
 - CB-XX CIRCUIT BREAKER (EXAMPLE CB-1B)
 - CCM CHILLER CONTROL MODULE
 - EXV ELECTRONIC EXPANSION VALVE
 - TB TERMINAL BLOCK
 - UPC UNIFIED PROTOCOL CONVERTER
 - VFD VARIABLE FREQUENCY DRIVE
 - VFG VARIABLE FREQUENCY (DRIVE) GATEWAY

Fig. 75 — 23XRV Controls Schematic Details (Rockwell LF-2 VFD)

LOW VOLTAGE FIELD WIRING

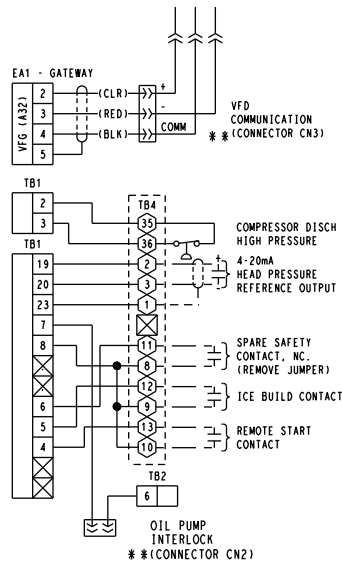

- LEGEND**
- DENOTES FIELD WIRING TERMINAL
 - DENOTES FACTORY WIRED TERMINAL
 - ** DENOTES VFD TO CONTROL PANEL CONNECTOR
 - DENOTES WIRE SPLICE
 - ⊞ DENOTES CONDUCTOR MALE/FEMALE CONNECTOR

HAZARDOUS VOLTAGE WIRING

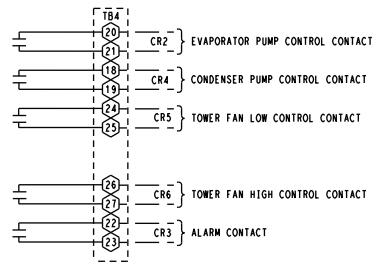

GATEWAY COMMUNICATION CARD

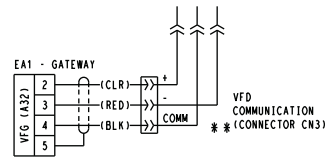

- ABBREVIATION LISTING**
- CN CONNECTOR
 - CR CONTROL RELAY
 - TB TERMINAL BLOCK
 - VFD VARIABLE FREQUENCY DRIVE
 - VFG VARIABLE FREQUENCY (DRIVE) GATEWAY

Fig. 76 — 23XRV Controls Schematic Details (Rockwell Standard Tier VFD)

LOW VOLTAGE FIELD WIRING

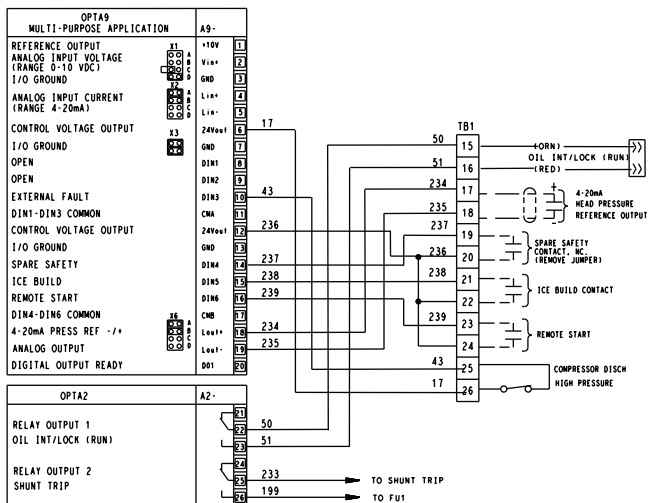

- LEGEND**
- DENOTES FACTORY WIRED TERMINAL
 - DENOTES WIRE SPLICE
 - ⊞ DENOTES CONDUCTOR MALE/FEMALE CONNECTOR

- ABBREVIATION LISTING**
- CN CONNECTOR
 - OPT OPTION CARD
 - TB TERMINAL BLOCK

HAZARDOUS VOLTAGE WIRING

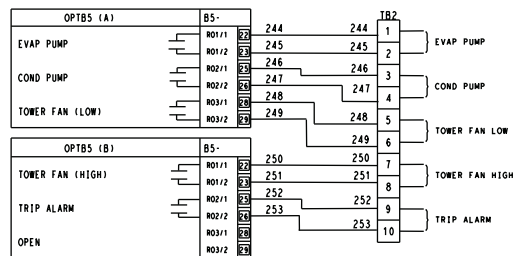

GATEWAY COMMUNICATION CARD

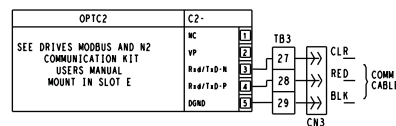
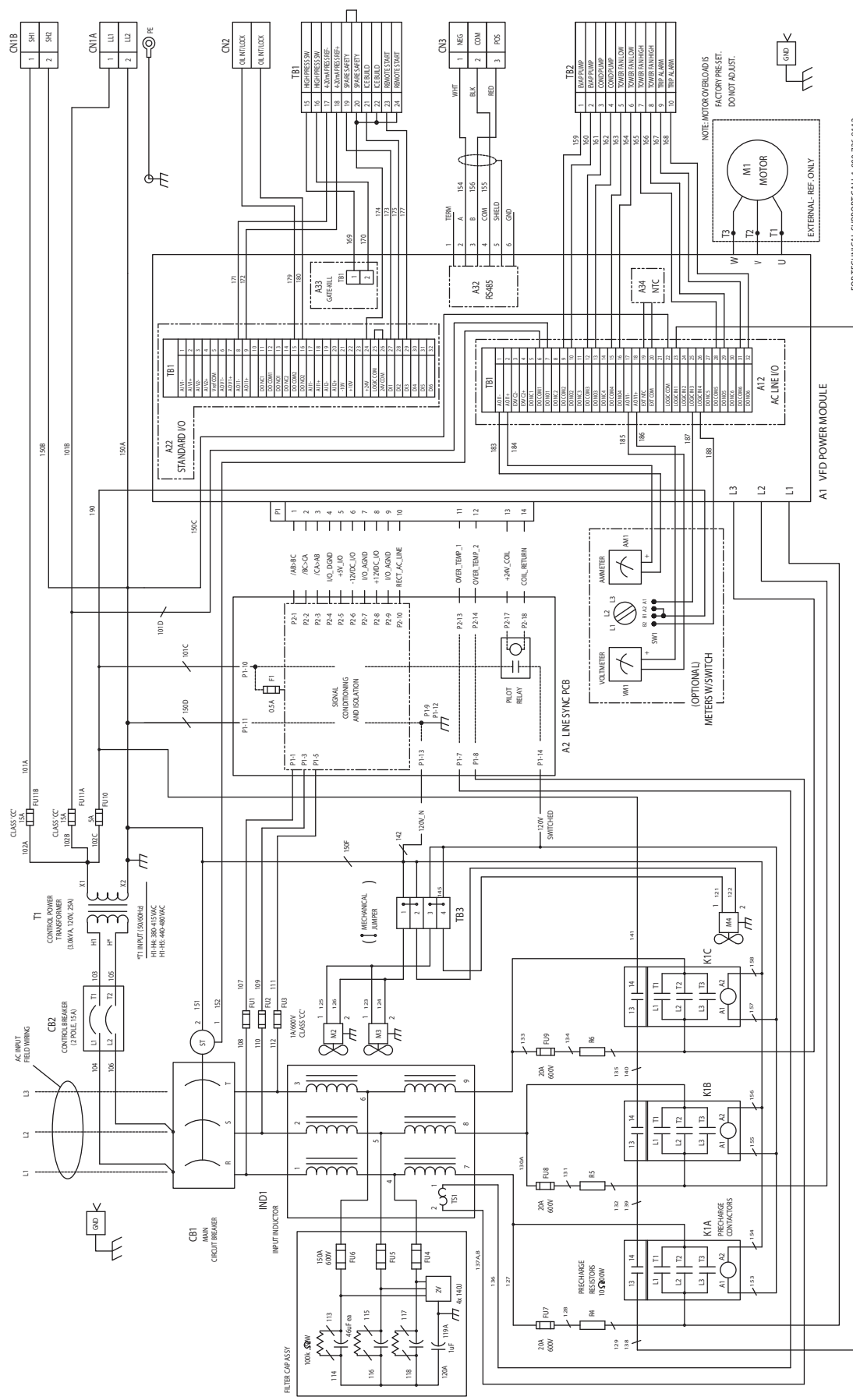

Fig. 77 — 23XRV Controls Schematic Details (Eaton Standard Tier VFD)



FOR TECHNICAL SUPPORT CALL 1-800-726-8112

Fig. 78 — 23XRV VFD Schematic (LF-2)

23XRV, 480V, 3PH, 50/60HZ SCHEMATIC DIAGRAM

MAIN CIRCUIT BREAKER/DRIVE RATING TABLE		
HP	UNIT RATING	MAIN CIRCUIT BREAKER CBI DRIVE FRAME SIZE
300HP	387A	600A
400HP	477A	700A

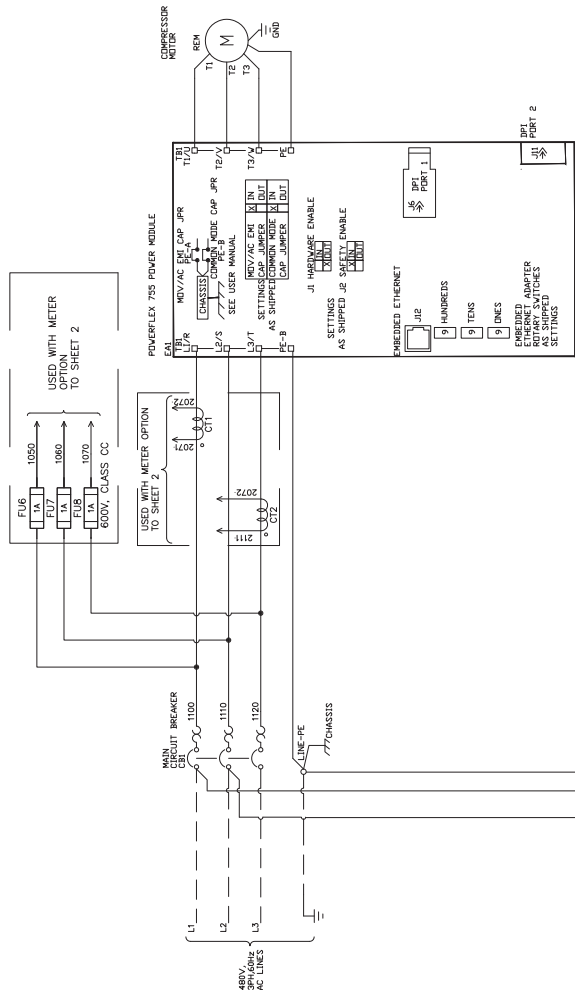

FUSE TABLE		
REF	FUSE DESCRIPTION	SUPPLIER & PART NUMBER
FU1	CLASS CC, 15/25A 600V	COMRO15/COMRO25
FU2	CLASS CC, 10A 600V	UTTEL FUSE, COMRO10
FU3	CLASS CC, 2.5A 600V	UTTEL FUSE, COMRO2.5
FU4	CLASS CC, 1A 600V	UTTEL FUSE, COMRO1

FUSE TABLE		
REF	FUSE DESCRIPTION	SUPPLIER & PART NUMBER
FU5	CLASS CC, 1A 600V	UTTEL FUSE, COMRO1
FU6	CLASS CC, 1A 600V	UTTEL FUSE, COMRO1
FU7	CLASS CC, 1A 600V	UTTEL FUSE, COMRO1
FU8	CLASS CC, 1A 600V	UTTEL FUSE, COMRO1

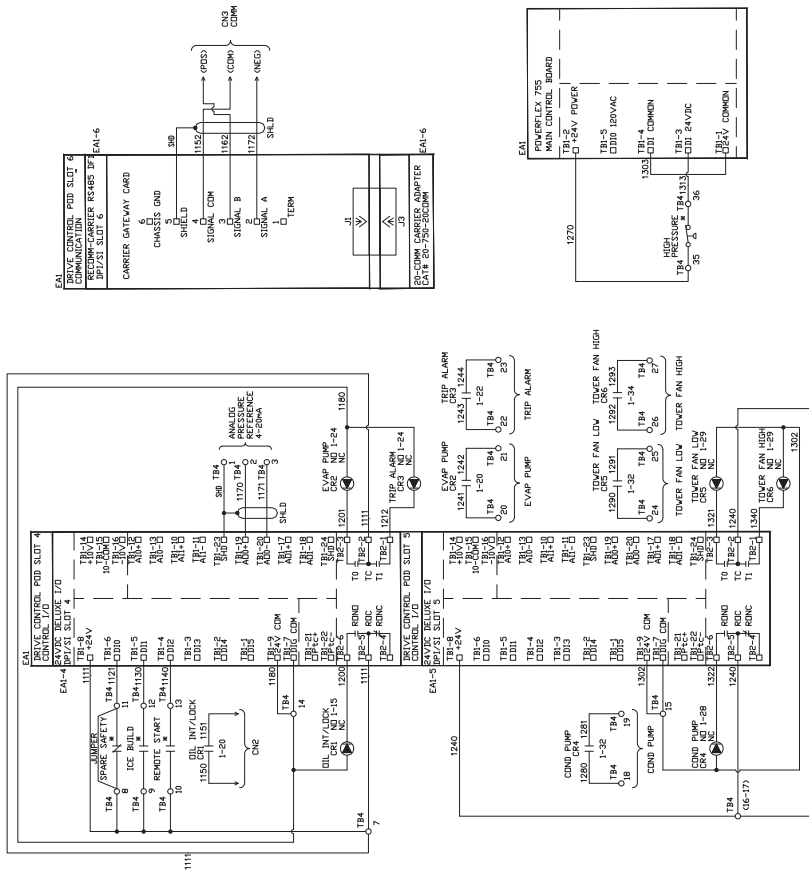

THIS EQUIPMENT CONFORMS TO CARRIER SPECIFICATION Z-424

Fig. 79 — 23XRV VFD Schematic (Rockwell Standard Tier VFD)

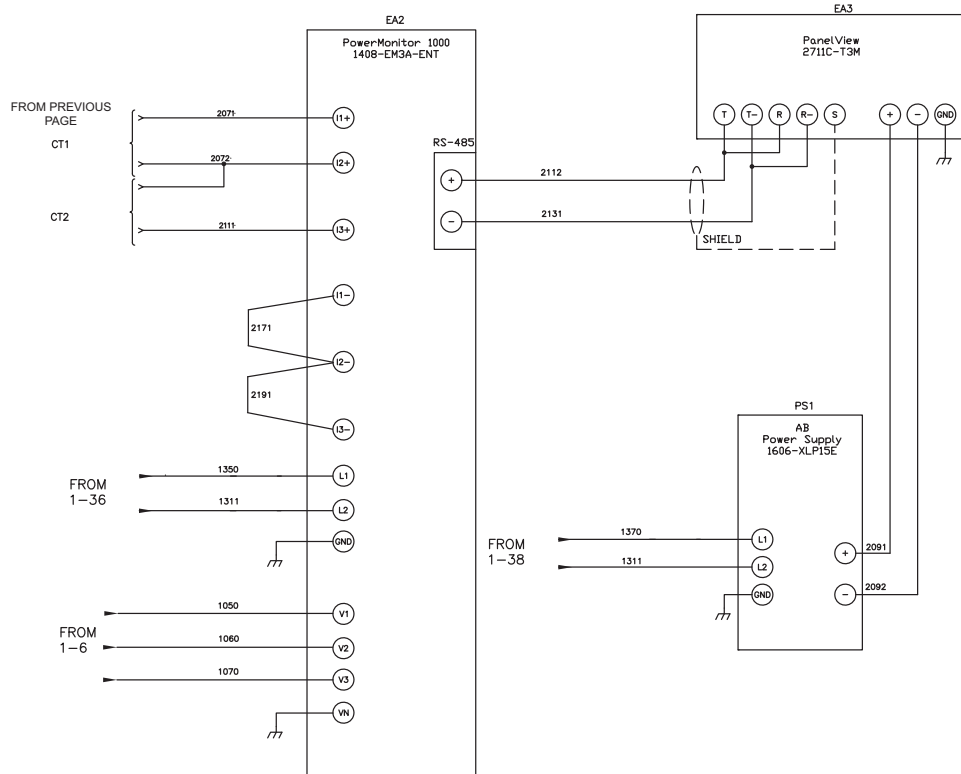

Fig. 79 — 23XRV Controls Schematic (Rockwell Standard Tier VFD Shown) (cont)

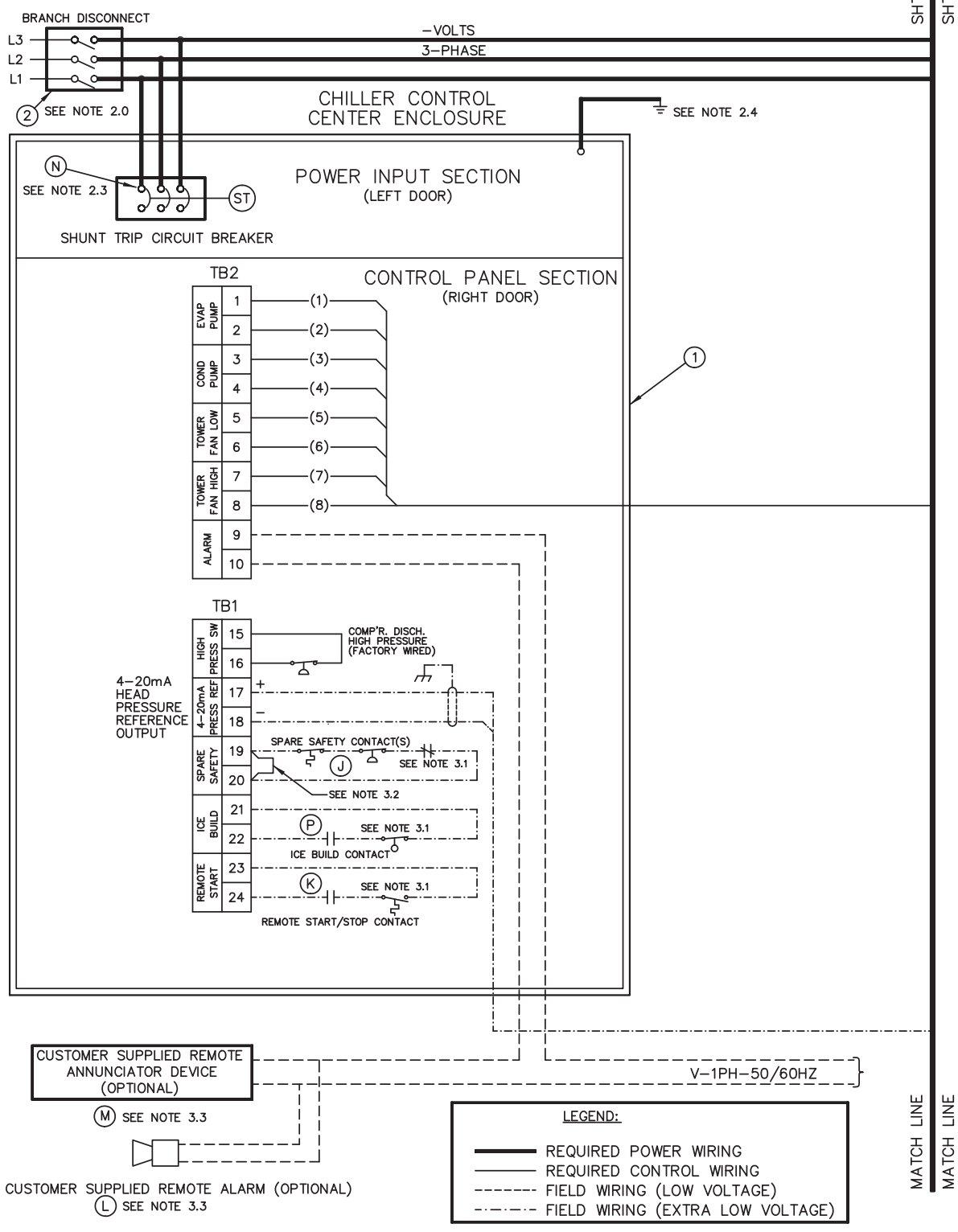

Fig. 80 — Typical Field Wiring Schematic (LF-2 VFD Shown)

ITEM	DESCRIPTION	
1	UNIT MOUNTED VFD WITH SHUNT TRIP CIRCUIT BREAKER (65K AMPS INTERRUPT/SHORT CIRCUIT)	
	UNIT MOUNTED VFD WITH SHUNT TRIP CIRCUIT BREAKER (100K AMPS INTERRUPT/SHORT CIRCUIT)	
	INCLUDES:	
	(1) N.O. CHILLED WATER PUMP CONTACT OUTPUT	
	(1) N.O. CONDENSER WATER PUMP CONTACT OUTPUT	
	(1) N.O. TOWER FAN LOW / #1 CONTACT OUTPUT	
	(1) N.O. TOWER FAN HIGH / #2 CONTACT OUTPUT	
	(1) N.O. ALARM CONTACT OUTPUT	
	(1) 4–20mA HEAD PRESSURE REFERENCE OUTPUT	
	(1) N.C. SPARE SAFETY (DRY) CONTACT INPUT	
	(1) N.O. REMOTE START (DRY) CONTACT INPUT	
	(1) N.O. ICE BUILD (DRY) CONTACT INPUT	
	PROTECTION	3 PHASE UNDER / OVER VOLTAGE PROTECTION (LINE SIDE)
		PHASE LOSS / IMBALANCE / REVERSAL PROTECTION (LINE SIDE)
		FREQUENCY SHIFT PROTECTION (LINE SIDE)
		OVER CURRENT PROTECTION (LINE AND LOAD SIDE)
		PHASE TO GROUND FAULT PROTECTION (LINE AND LOAD SIDE)
	METERING	3 PHASE AMPS (CHILLER DISPLAY LINE AND LOAD SIDE)
		3 PHASE VOLTS (CHILLER DISPLAY LINE SIDE)
		4–20mA KW TRANSDUCER OUTPUT (LINE SIDE) FROM CHILLER CONTROL MODULE (CCM)
KW HOURS / DEMAND KW (CHILLER DISPLAY LINE SIDE)		
KW METERING (CHILLER DISPLAY LINE AND LOAD SIDE)		
ANCILLARY	CONTROL POWER TRANSFORMER (3KVA)	
	CONTROLS AND OIL HEATER DISCONNECT	
	3 PHASE ANALOG VOLTS / AMPS METER PACKAGE (OPTION)	
	CE – MARKING (OPTION)	
2	SYSTEM FEEDER (SHORT CIRCUIT, GROUND FAULT & PROTECTION)	
A	EVAPORATOR LIQUID PUMP STARTER DISCONNECT	
B	EVAPORATOR LIQUID PUMP MOTOR STARTER	
C	CONDENSER LIQUID PUMP STARTER DISCONNECT	
D	CONDENSER LIQUID PUMP MOTOR STARTER	
E	COOLING TOWER FAN STARTER DISCONNECT (LOW FAN/#1)	
F	COOLING TOWER FAN STARTER (LOW FAN/#1)	
G	COOLING TOWER FAN STARTER DISCONNECT (HIGH FAN/#2)	
H	COOLING TOWER FAN STARTER (HIGH FAN/#2)	
J	SPARE SAFETY DEVICES [N.C.] SEE NOTE 3.1	
K	REMOTE START / STOP DEVICE [N.O.] SEE NOTE 3.1	
L	REMOTE ALARM SEE NOTE 3.3	
M	REMOTE ANNUNCIATOR SEE NOTE 3.3	
N	LINE SIDE LUG ADAPTERS SEE NOTE 2.3	
P	ICE BUILD START / TERMINATE DEVICE SEE NOTE 3.1	

See Notes on page 145.

Fig. 80 — Typical Field Wiring Schematic (LF-2 VFD Shown) (cont)

NOTES FOR FIG. 80

GENERAL

- 1.0 Variable frequency drive (VFD) shall be designed and manufactured in accordance with Carrier engineering requirements.
- 1.1 All field-supplied conductors, devices and the field-installation wiring, termination of conductors and devices, must be in compliance with all applicable codes and job specifications.
- 1.2 The routing of field-installed conduit and conductors and the location of field-installed devices, must not interfere with equipment access or the reading, adjusting or servicing of any component.
- 1.3 Equipment installation and all starting and control devices, must comply with details in equipment submittal drawings and literature.
- 1.4 Contacts and switches are shown in the position they would assume with the circuit de-energized and the chiller shut down.
- 1.5

⚠ WARNING

Do not use aluminum conductors. Contractor/installer assumes all liability resulting from the use of aluminum conductors within the VFD enclosure.

POWER WIRING TO VFD

- 2.0 Provide a means of disconnecting branch feeder power to VFD. Provide short circuit protection and interrupt capacity for branch feeder in compliance with all applicable codes.
- 2.1 If metal conduit is used for the power wires, the last 4 feet or greater should be flexible to avoid transmitting unit vibration into the power lines and to aid in serviceability.
- 2.2 Line side power conductor rating must meet VFD nameplate voltage and chiller minimum circuit ampacity.
- 2.3 Lug adapters may be required if installation conditions dictate that conductors be sized beyond the minimum ampacity required. Circuit breaker lugs will accommodate the quantity (#) and size cables (per phase) as shown in Table 40.
- 2.4 Compressor motor and controls must be grounded by using equipment grounding lug provided inside unit mounted VFD enclosure.

CONTROL WIRING

- 3.0 Field-supplied control conductors to be at least 18 AWG or larger.
- 3.1 Ice build start/terminate device contacts, remote start/stop device contacts and spare safety device contacts, (devices not supplied by Carrier), must have 24 VAC rating. Max current is 60 mA, nominal current is 10 mA. Switches with gold plated bifurcated contacts are recommended.

- 3.2 Remove jumper wire between TB1-19 and TB1-20 before connecting auxiliary safeties between these terminals.
- 3.3 Each integrated contact output can control loads (VA) for evaporator pump, condenser pump, tower fan low, tower fan high, and alarm annunciator devices rated 5 amps at 115 VAC and up to 3 amps at 277 VAC.

⚠ WARNING

Control wiring required for Carrier to start pumps and tower fan motors and establish flows must be provided to assure machine protection. If primary pump, tower fan and flow control is by other means, also provide a parallel means for control by Carrier. Failure to do so could result in machine freeze-up or overpressure.

Do not use control transformers in the control center as the power source for external or field-supplied contactor coils, actuator motors or any other loads.

- 3.4 Do not route control wiring carrying 30 V or less within a conduit or tray which has wires carrying 50 V or higher or along side wires carrying 50 V or higher.
- 3.5 Spare 4-20 mA output signal is designed for controllers with a non-grounded 4-20 mA input signal and a maximum input impedance of 500 ohms.
- 3.6 Flow devices to confirm evaporator or condenser pump flow are not required. However; if flow devices are used, wire as shown on drawing 23XRC1-1 (J3 lower). Remove jumper installed at these terminals and wire in a 4.3 K resistor in its place.

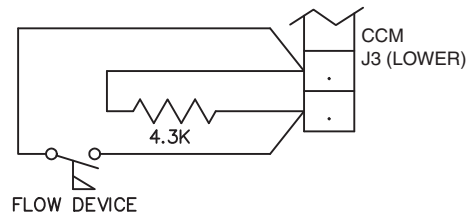

The flow device and resistor must be installed in parallel at these terminals such that the resistor provides a signal when the flow device is open.

Table 40 — Lug Capacity

VFD MAX INPUT AMPS	STANDARD 65K AIC LUG CAPACITY (PER PHASE)		OPTIONAL 100K AIC LUG CAPACITY (PER PHASE)	
	NO. CONDUCTORS	CONDUCTOR RANGE	NO. CONDUCTORS	CONDUCTOR RANGE
225A	3	2/0 — 400MCM	3	2/0 — 400MCM
338A	3	2/0 — 400MCM	3	2/0 — 400MCM
440A	3	2/0 — 400MCM	3	2/0 — 400MCM
520A	3	2/0 — 400MCM	3	2/0 — 400MCM
608A	3	2/0 — 400MCM	3	2/0 — 400MCM

NOTE: If larger lugs are required, they can be purchased from the manufacturer of the circuit breaker.

For larger lugs and cable reducers refer to PPS HH87LZ500.

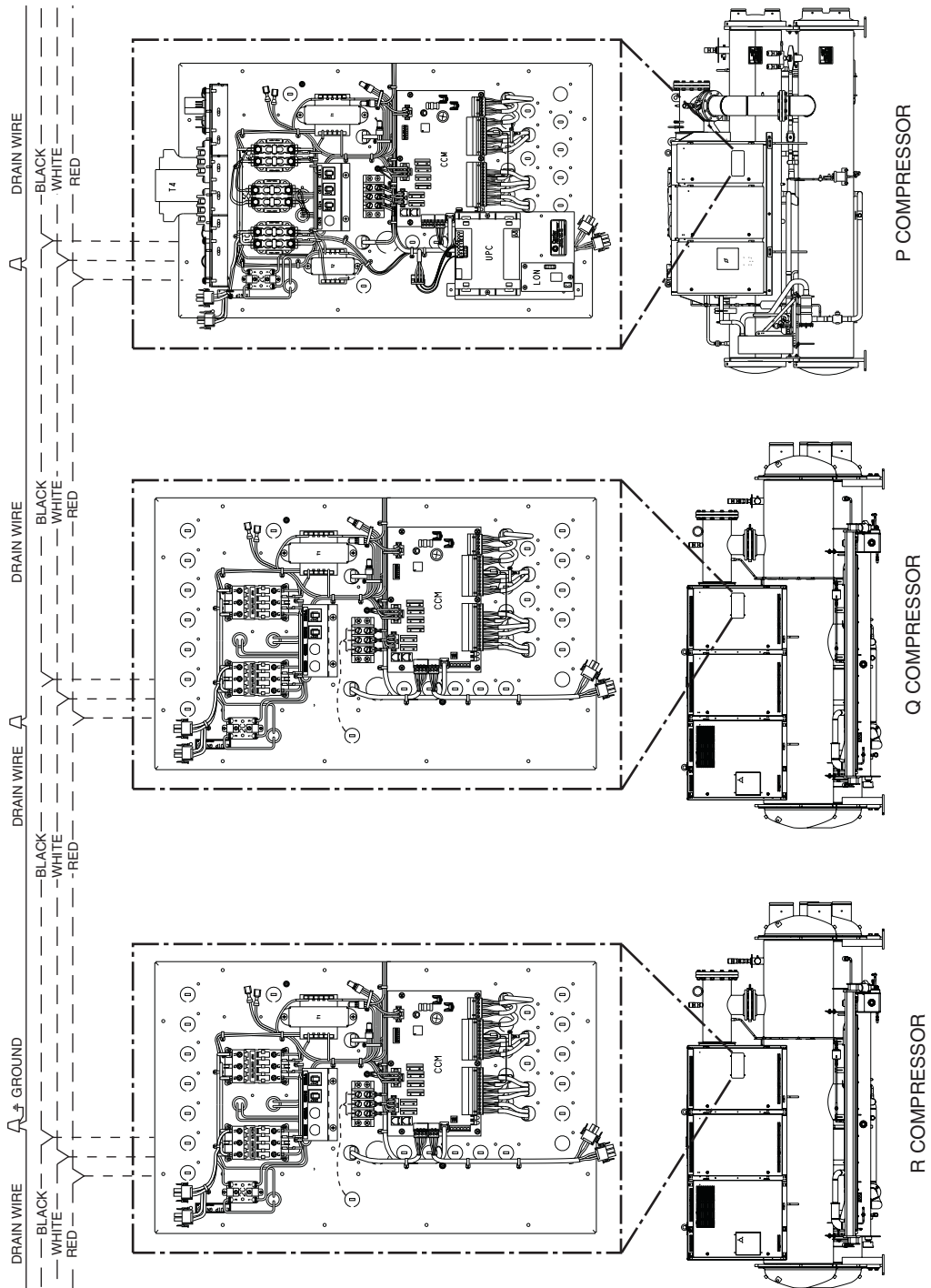

LEGEND
 — Factory Wiring
 - - - Field Wiring

NOTE: Field-supplied terminal strip must be located in control panel.

Fig. 81 — CCN Communication Wiring for Multiple Chillers (Typical)

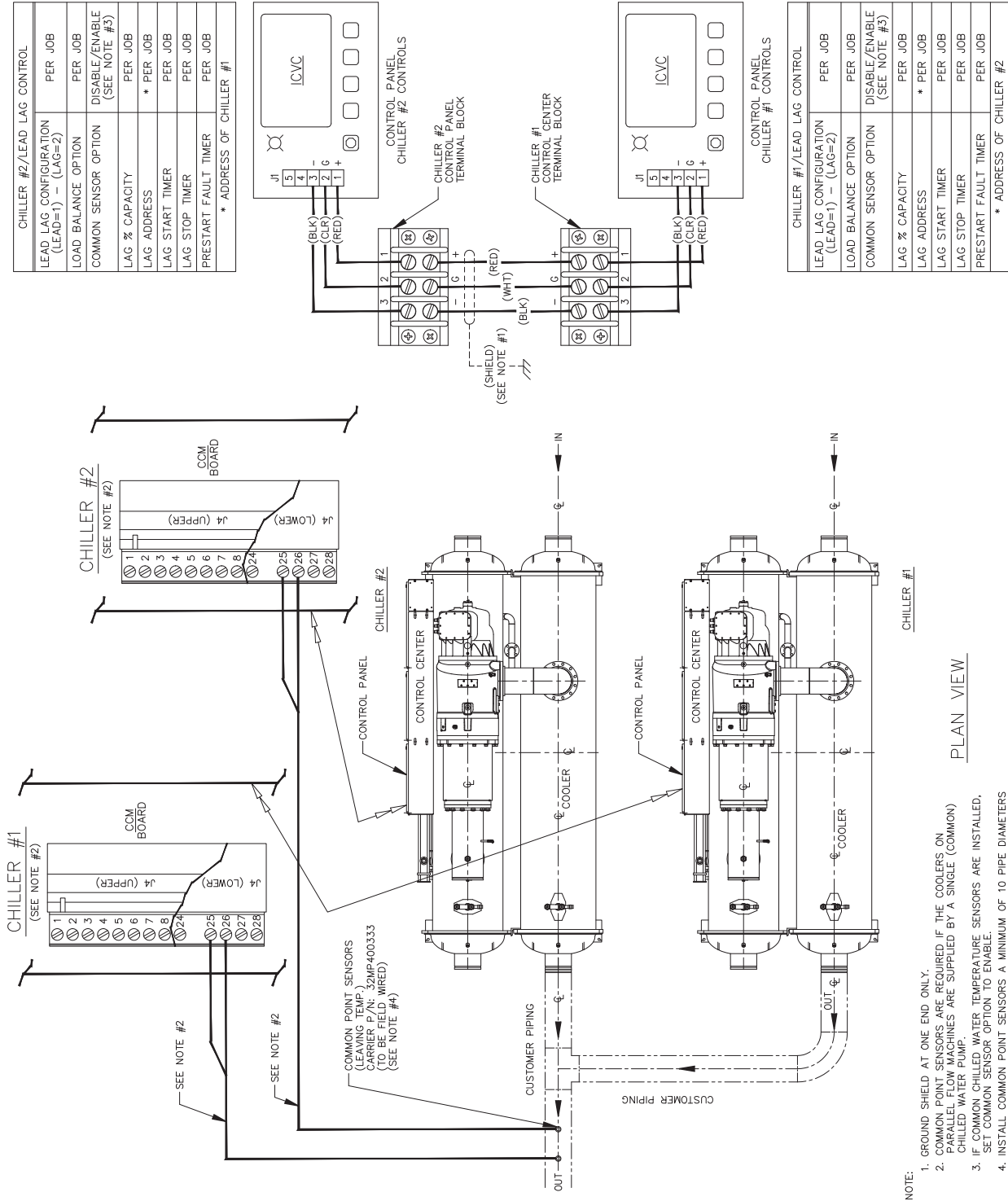
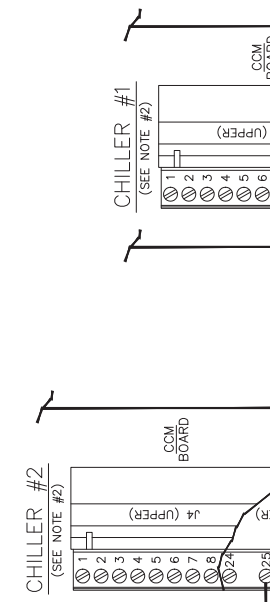
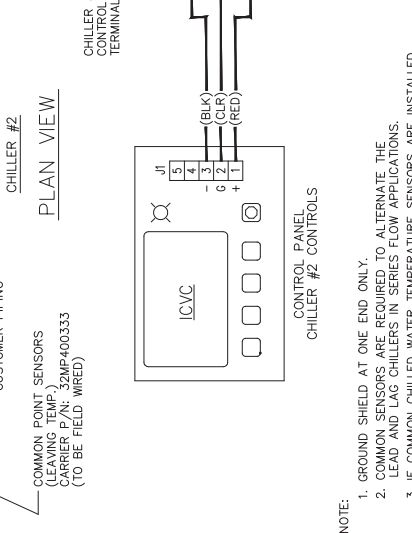
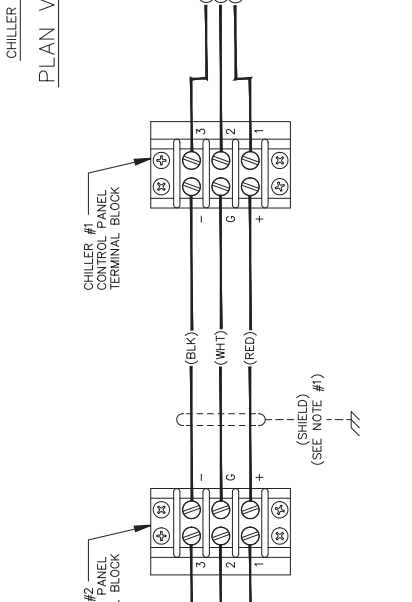
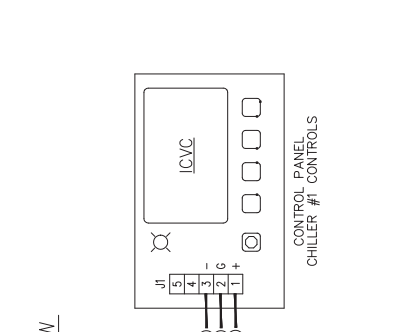
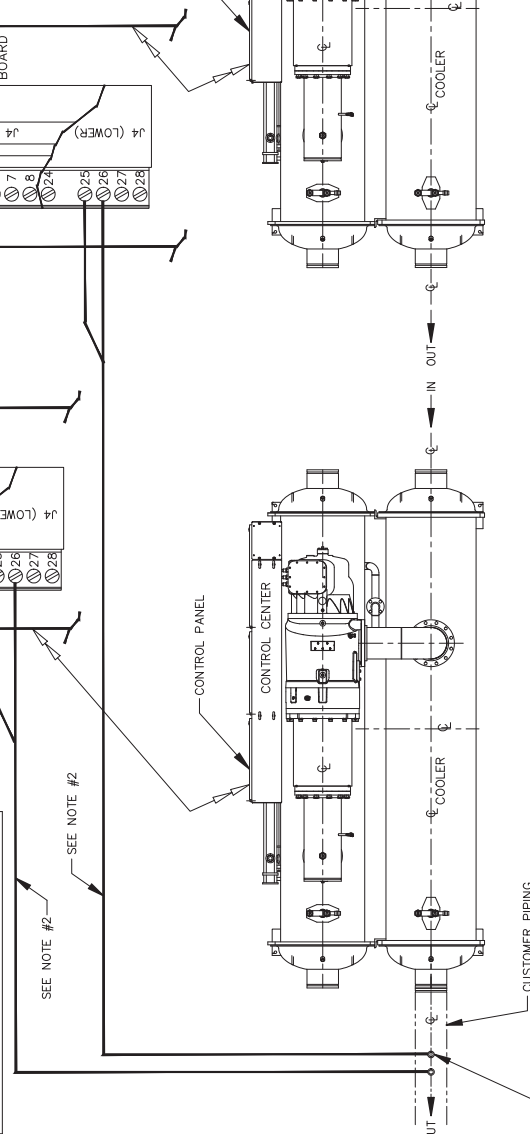

Fig. 82 — Lead/Lag Control Wiring (Parallel Flow Unit with R Compressor Shown)

CHILLER #1/LEAD LAG CONTROL	
LEAD LAG CONFIGURATION (LEAD=1) - (LAG=2)	PER JOB
LOAD BALANCE OPTION	PER JOB
COMMON SENSOR OPTION	DISABLE (SEE NOTE #3)
LAG % CAPACITY	PER JOB
LAG ADDRESS	* PER JOB
LAG START TIMER	PER JOB
LAG STOP TIMER	PER JOB
PRESTART FAULT TIMER	PER JOB
* ADDRESS OF CHILLER #2	



CHILLER #2/LEAD LAG CONTROL	
LEAD LAG CONFIGURATION (LEAD=1) - (LAG=2)	PER JOB
LOAD BALANCE OPTION	PER JOB
COMMON SENSOR OPTION	DISABLE (SEE NOTE #3)
LAG % CAPACITY	PER JOB
LAG ADDRESS	* PER JOB
LAG START TIMER	PER JOB
LAG STOP TIMER	PER JOB
PRESTART FAULT TIMER	PER JOB
* ADDRESS OF CHILLER #1	



- NOTE:
1. GROUND SHIELD AT ONE END ONLY.
 2. COMMON SENSORS ARE REQUIRED TO ALTERNATE THE LEAD AND LAG CHILLERS IN SERIES FLOW APPLICATIONS.
 3. IF COMMON CHILLED WATER TEMPERATURE SENSORS ARE INSTALLED, SET COMMON SENSOR OPTION TO ENABLE.

Fig. 83 — Lead/Lag Control Wiring (Series Flow Unit with R Compressor Shown)

APPENDIX A — ICVC PARAMETER INDEX

PARAMETER	MENU SOFTKEY	TABLE	SCREEN NAME	CONFIGURABLE
0=Temp,1=Contact,2=Both	SERVICE	EQUIPMENT SERVICE	OPTIONS	x
20mA Demand Limit Opt	SERVICE	EQUIPMENT SERVICE	RAMP_DEM	x
Active Delta P	STATUS		HEAT_EX	
Active Delta T	STATUS		HEAT_EX	
Active Demand Limit	STATUS		MAINSTAT	x
Actual VFD Speed	STATUS		COMPRESS	
Actual VFD Speed	STATUS		POWER	
Actual VFD Speed	SERVICE	CONTROL ALGORITHM STATUS	CAPACITY	
Actual VFD Speed	SERVICE	CONTROL ALGORITHM STATUS	VFD_HIST	
Alarm Relay	STATUS		MAINSTAT	
Alarm Routing	SERVICE	EQUIPMENT CONFIGURATION	NET_OPT	
Amps or KW Ramp %/Min.	SERVICE	EQUIPMENT SERVICE	RAMP_DEM	x
Amps/KW Ramp	SERVICE	CONTROL ALGORITHM STATUS	CAPACITY	
Anti Winding Min	SERVICE	EQUIPMENT SERVICE	SETUP5	x
Auto Chilled Liq Reset	STATUS		MAINSTAT	
Auto Demand Limit Input	STATUS		MAINSTAT	
Auto Restart Option	SERVICE	EQUIPMENT SERVICE	OPTIONS	x
Average Line Current	STATUS		POWER	
Average Line Voltage	STATUS		POWER	
Average Load Current	STATUS		POWER	
Base Demand Limit	SETPOINT		SETPOINT	x
Broadcast Option	SERVICE	EQUIPMENT CONFIGURATION	NET_OPT	
Calc Evap Sat Temp	STATUS		HEAT_EX	
Calc Evap Sat Temp	SERVICE	CONTROL ALGORITHM STATUS	OVERRIDE	
Capacity Control	SERVICE	CONTROL ALGORITHM STATUS	CAPACITY	
CapDelta	SERVICE	CONTROL ALGORITHM STATUS	CAPACITY	
CCN Mode ?	STATUS		ICVC_PWD	
Chill Liq Pulldown/Min	STATUS		HEAT_EX	
Chilled Liquid Deadband	SERVICE	EQUIPMENT SERVICE	SETUP1	x
Chilled Liquid Delta P	STATUS		HEAT_EX	x
Chilled Liquid Delta T	STATUS		HEAT_EX	
Chilled Liquid Flow	STATUS		MAINSTAT	
Chilled Liquid Pump	STATUS		MAINSTAT	x
Chilled Liquid Temp	STATUS		MAINSTAT	
Chilled Medium	SERVICE	EQUIPMENT SERVICE	SETUP1	x
Chilled Water Temp	SERVICE	CONTROL ALGORITHM STATUS	WSMCHLRE	
Chiller Fault State	SERVICE	CONTROL ALGORITHM STATUS	VFD_HIST	
Chiller Start/Stop	STATUS		MAINSTAT	x
CHL Delta T->Full Reset	SERVICE	EQUIPMENT SERVICE	TEMP_CTL	x
CHL Delta T->No Reset	SERVICE	EQUIPMENT SERVICE	TEMP_CTL	x
CHW Setpt Reset Value	SERVICE	CONTROL ALGORITHM STATUS	WSMCHLRE	
Commanded State	SERVICE	CONTROL ALGORITHM STATUS	WSMCHLRE	
Common Sensor Option	SERVICE	EQUIPMENT SERVICE	LEADLAG	x
Comp Discharge Alert	SERVICE	CONTROL ALGORITHM STATUS	OVERRIDE	
Comp Discharge Alert	SERVICE	EQUIPMENT SERVICE	SETUP1	x
Comp Discharge Temp	STATUS		COMPRESS	
Comp Discharge Temp	SERVICE	CONTROL ALGORITHM STATUS	OVERRIDE	
Comp Maximum Speed	STATUS		MAINSTAT	
Comp Maximum Speed	STATUS		COMPRESS	
Comp Maximum Speed	STATUS		POWER	
Comp Maximum Speed	SERVICE	CONTROL ALGORITHM STATUS	CAPACITY	
Comp Minimum Speed	STATUS		MAINSTAT	
Comp Minimum Speed	STATUS		COMPRESS	
Comp Minimum Speed	STATUS		POWER	
Comp Minimum Speed	SERVICE	CONTROL ALGORITHM STATUS	CAPACITY	
Comp Motor Frequency	STATUS		MAINSTAT	
Comp Motor Frequency	STATUS		COMPRESS	
Comp Motor Frequency	STATUS		POWER	
Comp Motor Frequency	SERVICE	CONTROL ALGORITHM STATUS	CAPACITY	
Comp Motor Frequency	SERVICE	CONTROL ALGORITHM STATUS	VFD_HIST	
Comp Motor RPM	STATUS		MAINSTAT	
Comp Motor RPM	STATUS		COMPRESS	
Comp Motor RPM	STATUS		POWER	

APPENDIX A — ICVC PARAMETER INDEX (cont)

PARAMETER	MENU SOFTKEY	TABLE	SCREEN NAME	CONFIGURABLE
Comp Motor RPM	SERVICE	CONTROL ALGORITHM STATUS	CAPACITY	
Comp Motor RPM	SERVICE	CONTROL ALGORITHM STATUS	VFD_HIST	
Comp Motor Temp Override	SERVICE	CONTROL ALGORITHM STATUS	VERRIDE	
Comp Motor Temp Override	SERVICE	EQUIPMENT SERVICE	SETUP1	x
Comp Motor Winding Temp	STATUS		COMPRESS	
Comp Motor Winding Temp	SERVICE	CONTROL ALGORITHM STATUS	VERRIDE	
Compressor 100% Speed	SERVICE		VFD_CONF	x
Compressor Ontime	STATUS		MAINSTAT	
Compressor Type	SERVICE	EQUIPMENT SERVICE	SETUP3	x
Cond Approach Alert	SERVICE	EQUIPMENT SERVICE	SETUP1	x
Cond EXV Max Movement	STATUS	COND_EXV	CEXV_MAX	
Cond EXV Max Movement	SERVICE	EQUIPMENT SERVICE	SETUP5	
Cond EXV Min Position	SERVICE	EQUIPMENT SERVICE	SETUP5	
Cond EXV Start Position	SERVICE	EQUIPMENT SERVICE	SETUP5	
Cond EXV Steps	STATUS	COND_EXV	CONDSTEP	
Cond Flow Delta P Cutout	SERVICE	EQUIPMENT SERVICE	SETUP1	x
Cond Level Deadband	SERVICE	EQUIPMENT SERVICE	SETUP5	x
Cond Level Error	STATUS	COND_EXV	LEV_ERR	
Cond Level High Limit	SERVICE	EQUIPMENT SERVICE	SETUP5	x
Cond Level Int Clamp	SERVICE	EQUIPMENT SERVICE	SETUP5	x
Cond Level Integral	STATUS	COND_EXV	LEV-INT	
Cond Level Int Gain	SERVICE	EQUIPMENT SERVICE	SETUP5	x
Cond Level Low Limit	SERVICE	EQUIPMENT SERVICE	SETUP5	
Cond Level Output	STATUS	COND_EXV	LEV_OUTV	
Cond Level Output	STATUS	COND_EXV	LEV_OUTP	
Cond Level Prop Gain	SERVICE	EQUIPMENT SERVICE	SETUP5	
Cond Level Range	STATUS	COND_EXV	LEV_RANG	
Cond Level Rounding	SERVICE	EQUIPMENT SERVICE	SETUP5	x
Cond Level Setpoint	STATUS	COND_EXV	LEV_SP	
Cond Level Setpoint	SERVICE	EQUIPMENT SERVICE	SETUP5	x
Cond Loop Timer	SERVICE	EQUIPMENT SERVICE	SETUP5	x
Cond Press Override	SERVICE	CONTROL ALGORITHM STATUS	VERRIDE	
Cond Press Override	SERVICE	EQUIPMENT SERVICE	SETUP1	x
Cond Refrig Temp Low Limit	SERVICE	EQUIPMENT SERVICE	SETUP3	x
Condenser Approach	STATUS		HEAT_EX	
Condenser EXV	STATUS	COND_EXV	COND_EXV	
Condenser Freeze Point	SERVICE	EQUIPMENT SERVICE	SETUP1	x
Condenser High Pressure	STATUS		VFD_STAT	
Condenser Liquid Delta P	STATUS		HEAT_EX	x
Condenser Liquid Flow	STATUS		MAINSTAT	
Condenser Liquid Level	STATUS	COND_EXV	COND_LEV	
Condenser Liquid Pump	STATUS		MAINSTAT	x
Condenser Pressure	STATUS		HEAT_EX	x
Condenser Pressure	SERVICE	CONTROL ALGORITHM STATUS	VERRIDE	
Condenser Refrig Temp	STATUS		HEAT_EX	
Condenser Refrig Temp	SERVICE	CONTROL ALGORITHM STATUS	VERRIDE	
Control Mode	STATUS		MAINSTAT	
Control Point	STATUS		MAINSTAT	x
Control Point	SERVICE	CONTROL ALGORITHM STATUS	CAPACITY	
Control Point Error	SERVICE	CONTROL ALGORITHM STATUS	CAPACITY	
Cooler Approach Limit	SERVICE	EQUIPMENT SERVICE	SETUP5	x
Current CHW Setpoint	SERVICE	CONTROL ALGORITHM STATUS	WSMCHLRE	
Current Mode	SERVICE	CONTROL ALGORITHM STATUS	LL_MAINT	
DC Bus Voltage	STATUS		POWER	
DC Bus Voltage	SERVICE	CONTROL ALGORITHM STATUS	VFD_HIST	
DC Bus Voltage Reference	STATUS		POWER	
DC Bus Voltage Reference	SERVICE	CONTROL ALGORITHM STATUS	VFD_HIST	
Decrease Ramp Time	SERVICE		VFD_CONF	x
Degrees Reset	SERVICE	EQUIPMENT SERVICE	TEMP_CTL	x
Degrees Reset at 20 mA	SERVICE	EQUIPMENT SERVICE	TEMP_CTL	x
Delta P at 0% (4 mA)	SERVICE	EQUIPMENT SERVICE	OPTIONS	x
Delta P at 100% (20 mA)	SERVICE	EQUIPMENT SERVICE	OPTIONS	x

APPENDIX A — ICVC PARAMETER INDEX (cont)

PARAMETER	MENU SOFTKEY	TABLE	SCREEN NAME	CONFIGURABLE
Demand Kilowatts	STATUS		POWER	
Demand Limit At 20 mA	SERVICE	EQUIPMENT SERVICE	RAMP_DEM	x
Demand Limit Decrease	SERVICE	EQUIPMENT CONFIGURATION	NET_OPT	
Demand Limit Inhibit	SERVICE	CONTROL ALGORITHM STATUS	CAPACITY	
Demand Limit Prop Band	SERVICE	EQUIPMENT SERVICE	RAMP_DEM	x
Demand Limit Source	SERVICE	EQUIPMENT SERVICE	RAMP_DEM	x
Demand Watts Interval	SERVICE	EQUIPMENT SERVICE	RAMP_DEM	x
Disable Service Password	STATUS		ICVC_PWD	
Disch Superheat Limit	SERVICE	EQUIPMENT SERVICE	SETUP5	x
Disch Sup Ht Corr Factor	SERVICE	EQUIPMENT SERVICE	SETUP5	x
Discharge Superheat	STATUS		COMPRESS	
Discharge Superheat	SERVICE	CONTROL ALGORITHM STATUS	OVERRIDE	
Discharge Superheat	STATUS	COND_EXV	DSH	
ECL Control Option	SERVICE	EQUIPMENT SERVICE	TEMP_CTL	x
ECL Delta T	SERVICE	CONTROL ALGORITHM STATUS	CAPACITY	
ECL Reset	SERVICE	CONTROL ALGORITHM STATUS	CAPACITY	
ECL Setpoint	SETPOINT		SETPOINT	x
Econ Activate Deadband	SERVICE	EQUIPMENT SERVICE	SETUP4	x
Econ Activate Speed	SERVICE	EQUIPMENT SERVICE	SETUP4	x
Econ EXV Max Movement	SERVICE	EQUIPMENT SERVICE	SETUP4	x
Econ EXV Position	STATUS	ECON_EXV	ECON_EXV	
Econ EXV Steps	STATUS	ECON_EXV	EEXV_TRG	
Econ Integral Gain	SERVICE	EQUIPMENT SERVICE	SETUP4	x
Econ PID Calc Time	SERVICE	EQUIPMENT SERVICE	SETUP4	x
Econ Superheat	STATUS	ECON_EXV	ECON_SH	
Econ Superheat Error	STATUS	ECON_EXV	SH_ERR	
Econ Superheat Setpoint	STATUS	ECON_EXV	ECONSHSP	
Economizer Gas Temp	STATUS	ECON_EXV	ECON_GAS	
Economizer Option	SERVICE	EQUIPMENT SERVICE	SETUP4	x
Economizer Pressure	STATUS	ECON_EXV	ECON_PRS	
Economizer Sat Temp	STATUS	ECON_EXV	ECON_SAT	
Emergency Stop	STATUS		MAINSTAT	
Enable Reset Type	SERVICE	EQUIPMENT SERVICE	TEMP_CTL	x
Entering Chilled Liquid	STATUS		HEAT_EX	
Entering Chilled Liquid	SERVICE	CONTROL ALGORITHM STATUS	CAPACITY	
Entering Cond Liquid	STATUS		HEAT_EX	
Equipment Status	SERVICE	CONTROL ALGORITHM STATUS	WSMCHLRE	
Evap App Corr Factor	SERVICE	EQUIPMENT SERVICE	SETUP5	x
Evap Approach Alert	SERVICE	EQUIPMENT SERVICE	SETUP1	x
Evap Approach Alert Reset Gain	SERVICE	EQUIPMENT SERVICE	SETUP5	x
Evap Flow Delta P Cutout	SERVICE	EQUIPMENT SERVICE	SETUP1	x
Evap Refrig Liquid Temp	STATUS		HEAT_EX	
Evap Refrig Trippoint	SERVICE	EQUIPMENT SERVICE	SETUP1	x
Evap Sat Override Temp	SERVICE	CONTROL ALGORITHM STATUS	OVERRIDE	
Evaporator Approach	STATUS		HEAT_EX	
Evaporator Approach	STATUS	COND_EXV	EVAP_APP	
Evaporator Pressure	STATUS		HEAT_EX	x
Feed Forward Gain	SERVICE	EQUIPMENT SERVICE	SETUP5	x
Feed Forward Threshold	SERVICE	EQUIPMENT SERVICE	SETUP5	x
Fine Tune Active?	STATUS	COND_EXV	FT_ACTIVE	
Fine Tune Enabled?	SERVICE	EQUIPMENT SERVICE	SETUP5	x
Fine Tune Threshold	SERVICE	EQUIPMENT SERVICE	SETUP5	x
Flow Delta P Display	SERVICE	EQUIPMENT SERVICE	SETUP1	x
Flux Current	STATUS		POWER	
Flux Current	SERVICE	CONTROL ALGORITHM STATUS	VFD_HIST	
Freeze Margin at Start	SERVICE	EQUIPMENT SERVICE	SETUP5	x
Frequency Fault	STATUS		VFD_STAT	
Full Load Point (T2,P2)	SERVICE	EQUIPMENT SERVICE	OPTIONS	x
Ground Fault	STATUS		VFD_STAT	
Ground Fault Current	STATUS		POWER	
Ground Fault Current	SERVICE	CONTROL ALGORITHM STATUS	VFD_HIST	
Group Number	SERVICE	EQUIPMENT CONFIGURATION	NET_OPT	x
Head Pressure Reference	STATUS		HEAT_EX	
HGBP Deadband	SERVICE	EQUIPMENT SERVICE	OPTIONS	x

APPENDIX A — ICVC PARAMETER INDEX (cont)

PARAMETER	MENU SOFTKEY	TABLE	SCREEN NAME	CONFIGURABLE
HGBP Delta P1	SERVICE	EQUIPMENT SERVICE	OPTIONS	x
HGBP Delta T	STATUS		HEAT_EX	
HGBP Delta T1	SERVICE	EQUIPMENT SERVICE	OPTIONS	x
HGBP Delta T2	SERVICE	EQUIPMENT SERVICE	OPTIONS	x
HGBP Delta P2	SERVICE	EQUIPMENT SERVICE	OPTIONS	x
HGBP Off Delta Speed	SERVICE	EQUIPMENT SERVICE	OPTIONS	x
HGBP On Delta Speed	SERVICE	EQUIPMENT SERVICE	OPTIONS	x
HGBP Option	SERVICE	EQUIPMENT SERVICE	OPTIONS	x
High DC Bus Voltage	STATUS		VFD_STAT	
High Line Voltage	STATUS		VFD_STAT	
Hot Gas Bypass Relay	STATUS		HEAT_EX	
Humidity Sensor Input	STATUS		POWER	
Ice Build Contact	STATUS		MAINSTAT	
Ice Build Option	SERVICE	EQUIPMENT SERVICE	OPTIONS	x
Ice Build Recycle	SERVICE	EQUIPMENT SERVICE	OPTIONS	x
Ice Build Setpoint	SETPOINT		SETPOINT	x
Ice Build Termination	SERVICE	EQUIPMENT SERVICE	OPTIONS	x
Increase Ramp Time	SERVICE		VFD_CONF	x
Inverter Overcurrent	STATUS		VFD_STAT	
Inverter Overload	STATUS		POWER	
Inverter Overtemp	STATUS		VFD_STAT	
Inverter Power Fault	STATUS		VFD_STAT	
Inverter PWM Frequency	SERVICE		VFD_CONF	x
Inverter Temp Override	SERVICE	CONTROL ALGORITHM STATUS	OVERRIDE	
Inverter Temp Override	SERVICE	EQUIPMENT SERVICE	SETUP1	x
Inverter Temperature	STATUS		POWER	
Inverter Temperature	SERVICE	CONTROL ALGORITHM STATUS	OVERRIDE	
Inverter Temperature	SERVICE	CONTROL ALGORITHM STATUS	VFD_HIST	
LAG % Capacity	SERVICE	EQUIPMENT SERVICE	LEADLAG	x
LAG Address	SERVICE	EQUIPMENT SERVICE	LEADLAG	x
LAG CHILLER: Mode	SERVICE	CONTROL ALGORITHM STATUS	LL_MAINT	
LAG START Time	SERVICE	CONTROL ALGORITHM STATUS	LL_MAINT	
LAG START Timer	SERVICE	EQUIPMENT SERVICE	LEADLAG	x
LAG STOP Time	SERVICE	CONTROL ALGORITHM STATUS	LL_MAINT	
LAG STOP Timer	SERVICE	EQUIPMENT SERVICE	LEADLAG	x
LCL Reset	SERVICE	CONTROL ALGORITHM STATUS	CAPACITY	
LCL Setpoint	SETPOINT		SETPOINT	x
LEAD CHILLER in Control	SERVICE	CONTROL ALGORITHM STATUS	LL_MAINT	
LEAD/LAG: Configuration	SERVICE	EQUIPMENT SERVICE	LEADLAG	x
LEAD/LAG: Configuration	SERVICE	CONTROL ALGORITHM STATUS	LL_MAINT	
Leaving Chilled Liquid	STATUS		HEAT_EX	
Leaving Chilled Liquid	SERVICE	CONTROL ALGORITHM STATUS	CAPACITY	
Leaving Cond Liquid	STATUS		HEAT_EX	
Line Active Current	STATUS		POWER	
Line Active Current	SERVICE	CONTROL ALGORITHM STATUS	VFD_HIST	
Line Active Voltage	STATUS		POWER	
Line Active Voltage	SERVICE	CONTROL ALGORITHM STATUS	VFD_HIST	
Line Current % Imbalance	SERVICE		VFD_CONF	x
Line Current Imbal Time	SERVICE		VFD_CONF	x
Line Current Imbalance	STATUS		POWER	
Line Current Imbalance	STATUS		VFD_STAT	
Line Current Imbalance	SERVICE	CONTROL ALGORITHM STATUS	VFD_HIST	
Line Current Ph1(R)	STATUS		POWER	
Line Current Ph1(R)	SERVICE	CONTROL ALGORITHM STATUS	VFD_HIST	
Line Current Ph2(S)	STATUS		POWER	
Line Current Ph2(S)	SERVICE	CONTROL ALGORITHM STATUS	VFD_HIST	
Line Current Ph3(T)	STATUS		POWER	
Line Current Ph3(T)	SERVICE	CONTROL ALGORITHM STATUS	VFD_HIST	
Line Frequency	STATUS		POWER	
Line Frequency	SERVICE	CONTROL ALGORITHM STATUS	VFD_HIST	
Line Kilowatts	STATUS		POWER	
Line Phase Reversal	STATUS		VFD_STAT	
Line Power Factor	STATUS		POWER	

APPENDIX A — ICVC PARAMETER INDEX (cont)

PARAMETER	MENU SOFTKEY	TABLE	SCREEN NAME	CONFIGURABLE
Line Power Factor	SERVICE	CONTROL ALGORITHM STATUS	VFD_HIST	
Line Reactive Current	STATUS		POWER	
Line Reactive Current	SERVICE	CONTROL ALGORITHM STATUS	VFD_HIST	
Line Reactive Voltage	STATUS		POWER	
Line Reactive Voltage	SERVICE	CONTROL ALGORITHM STATUS	VFD_HIST	
Line Volt Imbalance Time	SERVICE		VFD_CONF	x
Line Voltage % Imbalance	SERVICE		VFD_CONF	x
Line Voltage Imbalance	STATUS		POWER	
Line Voltage Imbalance	STATUS		VFD_STAT	
Line Voltage Imbalance	SERVICE	CONTROL ALGORITHM STATUS	VFD_HIST	
Line Voltage Ph1(RS)	STATUS		POWER	
Line Voltage Ph1(RS)	SERVICE	CONTROL ALGORITHM STATUS	VFD_HIST	
Line Voltage Ph2(ST)	STATUS		POWER	
Line Voltage Ph2(ST)	SERVICE	CONTROL ALGORITHM STATUS	VFD_HIST	
Line Voltage Ph3(TR)	STATUS		POWER	
Line Voltage Ph3(TR)	SERVICE	CONTROL ALGORITHM STATUS	VFD_HIST	
Liquid Flow Verify Time	SERVICE	EQUIPMENT SERVICE	SETUP1	x
Load Balance Option	SERVICE	CONTROL ALGORITHM STATUS	LL_MAINT	
Load Balance Option	SERVICE	EQUIPMENT SERVICE	LEADLAG	x
Load Current Ph1(U)	STATUS		POWER	
Load Current Ph1(U)	SERVICE	CONTROL ALGORITHM STATUS	VFD_HIST	
Load Current Ph2(V)	STATUS		POWER	
Load Current Ph2(V)	SERVICE	CONTROL ALGORITHM STATUS	VFD_HIST	
Load Current Ph3(W)	STATUS		POWER	
Load Current Ph3(W)	SERVICE	CONTROL ALGORITHM STATUS	VFD_HIST	
Loadshed	SERVICE	CONTROL ALGORITHM STATUS	LOADSHED	
Loadshed Timer	SERVICE	CONTROL ALGORITHM STATUS	LOADSHED	
Low DC Bus Voltage	STATUS		VFD_STAT	
Low Line Voltage	STATUS		VFD_STAT	
Maximum Loadshed Time	SERVICE	EQUIPMENT CONFIGURATION	NET_OPT	
Min. Load Point (T1,P1)	SERVICE	EQUIPMENT SERVICE	OPTIONS	x
Minimum Output	SERVICE	EQUIPMENT SERVICE	OPTIONS	x
Motor Amps Not Sensed	STATUS		VFD_STAT	
Motor Current % Imbalance	SERVICE		VFD_CONF	x
Motor Current Imbal Time	SERVICE		VFD_CONF	x
Motor Current Imbalance	STATUS		POWER	
Motor Current Imbalance	STATUS		VFD_STAT	
Motor Current Imbalance	SERVICE	CONTROL ALGORITHM STATUS	VFD_HIST	
Motor Kilowatt Hours	STATUS		POWER	
Motor Kilowatts	STATUS		POWER	
Motor Nameplate Amps	SERVICE		VFD_CONF	x
Motor Nameplate KW	SERVICE		VFD_CONF	x
Motor Nameplate RPM	SERVICE		VFD_CONF	x
Motor Nameplate Voltage	SERVICE		VFD_CONF	x
Motor Overload	STATUS		POWER	
Motor Overload	STATUS		VFD_STAT	
Motor Overload	SERVICE	CONTROL ALGORITHM STATUS	VFD_HIST	
Motor Power Factor	STATUS		POWER	
Motor Power Factor	SERVICE	CONTROL ALGORITHM STATUS	VFD_HIST	
Motor Rated Load Amps	SERVICE		VFD_CONF	x
Motor Rated Load KW	SERVICE		VFD_CONF	x
Occupied?	STATUS		MAINSTAT	
Oil Heater Relay	STATUS		COMPRESS	
Oil Press Verify Time	SERVICE	EQUIPMENT SERVICE	SETUP1	x
Oil Pressure Delta P	STATUS		MAINSTAT	
Oil Pressure Delta P	STATUS		COMPRESS	x
Oil Pump Relay	STATUS		MAINSTAT	
Oil Pump Relay	STATUS		COMPRESS	
Oil Reclaim Min Output	SERVICE	EQUIPMENT SERVICE	SETUP2	x
Oil Reclaim Output	STATUS		MAINSTAT	
Oil Reclaim Output	STATUS		HEAT_EX	
Oil Sump Temp	STATUS		MAINSTAT	
Oil Sump Temp	STATUS		COMPRESS	

APPENDIX A — ICVC PARAMETER INDEX (cont)

PARAMETER	MENU SOFTKEY	TABLE	SCREEN NAME	CONFIGURABLE
PPM at 20 mA	SERVICE	EQUIPMENT SERVICE	OPTIONS	x
PRESTART FAULT Time	SERVICE	CONTROL ALGORITHM STATUS	LL_MAINT	
PRESTART FAULT Timer	SERVICE	EQUIPMENT SERVICE	LEADLAG	x
Proportional Dec Band	SERVICE	EQUIPMENT SERVICE	SETUP2	x
Proportional ECL Gain	SERVICE	EQUIPMENT SERVICE	SETUP2	x
Proportional Inc Band	SERVICE	EQUIPMENT SERVICE	SETUP2	x
Pulldown Ramp Type:	SERVICE	EQUIPMENT SERVICE	RAMP_DEM	x
PULLDOWN Time	SERVICE	CONTROL ALGORITHM STATUS	LL_MAINT	
PULLDOWN Timer	SERVICE	EQUIPMENT SERVICE	LEADLAG	x
Pulldown: Delta T / Min	SERVICE	CONTROL ALGORITHM STATUS	LL_MAINT	
Rated Line Amps	SERVICE		VFD_CONF	x
Rated Line Kilowatts	SERVICE		VFD_CONF	x
Rated Line Voltage	SERVICE		VFD_CONF	x
Re-alarm Time	SERVICE	EQUIPMENT CONFIGURATION	NET_OPT	
Reclaim Delta T	STATUS		HEAT_EX	
Recovery Start Request	SERVICE	CONTROL ALGORITHM STATUS	LL_MAINT	
Rectifier Overcurrent	STATUS		VFD_STAT	
Rectifier Overload	STATUS		POWER	
Rectifier Overtemp	STATUS		VFD_STAT	
Rectifier Power Fault	STATUS		VFD_STAT	
Rectifier Temp Override	SERVICE	CONTROL ALGORITHM STATUS	OVERRIDE	
Rectifier Temp Override	SERVICE	EQUIPMENT SERVICE	SETUP1	x
Rectifier Temperature	STATUS		POWER	
Rectifier Temperature	SERVICE	CONTROL ALGORITHM STATUS	OVERRIDE	
Rectifier Temperature	SERVICE	CONTROL ALGORITHM STATUS	VFD_HIST	
Redline	SERVICE	CONTROL ALGORITHM STATUS	LOADSHED	
Refrig Leak Alarm PPM	SERVICE	EQUIPMENT SERVICE	OPTIONS	x
Refrig Leak Sensor PPM	STATUS		MAINSTAT	
Refrig Override Delta T	SERVICE	EQUIPMENT SERVICE	SETUP1	x
Relative Humidity	STATUS		POWER	
Remote Contacts Option	SERVICE	EQUIPMENT SERVICE	OPTIONS	x
Remote Reset Option	STATUS		ICVC_PWD	x
Remote Reset Sensor	STATUS		MAINSTAT	
Remote Start Contact	STATUS		MAINSTAT	x
Remote Temp->Full Reset	SERVICE	EQUIPMENT SERVICE	TEMP_CTL	x
Remote Temp->No Reset	SERVICE	EQUIPMENT SERVICE	TEMP_CTL	x
Reset Alarm ?	STATUS		ICVC_PWD	
Restart Delta T	SERVICE	EQUIPMENT SERVICE	SETUP1	x
Run Status	STATUS		MAINSTAT	
Run Status	SERVICE	CONTROL ALGORITHM STATUS	LL_MAINT	
Satisfied?	SERVICE	CONTROL ALGORITHM STATUS	LL_MAINT	
Schedule Number	SERVICE	EQUIPMENT CONFIGURATION	NET_OPT	
Service Ontime	STATUS		MAINSTAT	x
Shunt Trip Relay	STATUS		MAINSTAT	
Shutdown Delta Speed	SERVICE	EQUIPMENT SERVICE	SETUP1	x
Single Cycle Dropout	STATUS		VFD_STAT	
Single Cycle Dropout	SERVICE		VFD_CONF	x
Skip Frequency 1	SERVICE		VFD_CONF	x
Skip Frequency 2	SERVICE		VFD_CONF	x
Skip Frequency 3	SERVICE		VFD_CONF	x
Skip Frequency Band	SERVICE		VFD_CONF	x
Soft Stop Amps Threshold	SERVICE	EQUIPMENT SERVICE	OPTIONS	x
Spare Safety Input	STATUS		MAINSTAT	
Spare Temp #1 Enable	SERVICE	EQUIPMENT SERVICE	SETUP1	x
Spare Temp #1 Limit	SERVICE	EQUIPMENT SERVICE	SETUP1	x
Spare Temp #2 Enable	SERVICE	EQUIPMENT SERVICE	SETUP1	x
Spare Temp #2 Limit	SERVICE	EQUIPMENT SERVICE	SETUP1	x
Spare Temperature 1	STATUS		COMPRESS	
Spare Temperature 1	SERVICE	CONTROL ALGORITHM STATUS	LL_MAINT	

APPENDIX A — ICVC PARAMETER INDEX (cont)

PARAMETER	MENU SOFTKEY	TABLE	SCREEN NAME	CONFIGURABLE
Percent Line Current	STATUS		MAINSTAT	
Percent Line Current	STATUS		POWER	
Percent Line Kilowatts	STATUS		MAINSTAT	
Percent Line Kilowatts	STATUS		POWER	
Percent Line Voltage	STATUS		POWER	
Percent Load Current	STATUS		POWER	
Percent Motor Kilowatts	STATUS		POWER	
Spare Temperature 2	STATUS		COMPRESS	
Spare Temperature 2	SERVICE	CONTROL ALGORITHM STATUS	LL_MAINT	
Stall Delta % Amps	SERVICE	EQUIPMENT SERVICE	OPTIONS	x
Stall Protection Counts	STATUS		COMPRESS	
Stall Time Period	SERVICE	EQUIPMENT SERVICE	OPTIONS	x
STANDBY % Capacity	SERVICE	EQUIPMENT SERVICE	LEADLAG	x
STANDBY Address	SERVICE	EQUIPMENT SERVICE	LEADLAG	x
STANDBY Chiller Option	SERVICE	EQUIPMENT SERVICE	LEADLAG	x
STANDBY CHILLER: Mode	SERVICE	CONTROL ALGORITHM STATUS	LL_MAINT	
Start Acceleration Fault	STATUS		VFD_STAT	
Start Complete	STATUS		MAINSTAT	
Start Complete	STATUS		VFD_STAT	
Start Delay	SERVICE	EQUIPMENT SERVICE	SETUP5	x
Start Inhibit Timer	STATUS		MAINSTAT	
Start/Stop	SERVICE	CONTROL ALGORITHM STATUS	LL_MAINT	
Starts in 12 Hours	STATUS		MAINSTAT	
Stop Complete	STATUS		MAINSTAT	
Stop Complete	STATUS		VFD_STAT	
Stop Fault	STATUS		VFD_STAT	
Sump Heater Turn Off Delta T	SERVICE	EQUIPMENT SERVICE	SETUP3	x
Sump Heater Turn Off Speed	SERVICE	EQUIPMENT SERVICE	SETUP3	x
Sump Heater Turn On Lift	SERVICE	EQUIPMENT SERVICE	SETUP3	x
Sump Heater Turn Speed	SERVICE	EQUIPMENT SERVICE	SETUP3	x
Superheat Setpoint	SERVICE	EQUIPMENT SERVICE	SETUP4	x
System Alert/Alarm	STATUS		MAINSTAT	
Target Condenser EXV	STATUS	COND_EXV	CEXV_TRG	x
Target Economizer EXV	STATUS	ECON_EXV	EEV_TRG	x
Target VFD Speed	STATUS		COMPRESS	x
Target VFD Speed	SERVICE	CONTROL ALGORITHM STATUS	CAPACITY	
Temp Pulldown Ramp/Min	SERVICE	EQUIPMENT SERVICE	TEMP_CTL	x
Temperature Reset	STATUS		MAINSTAT	
Temperature Reset	SERVICE	EQUIPMENT SERVICE	TEMP_CTL	x
Torque Current	STATUS		POWER	
Torque Current	SERVICE	CONTROL ALGORITHM STATUS	VFD_HIST	
Total Compressor Starts	STATUS		MAINSTAT	
Total Error + Resets	SERVICE	CONTROL ALGORITHM STATUS	CAPACITY	
Tower Fan High Setpoint	SETPOINT		SETPOINT	x
Tower Fan Relay High	STATUS		MAINSTAT	x
Tower Fan Relay Low	STATUS		MAINSTAT	x
Turn Off Lift	SERVICE	EQUIPMENT SERVICE	SETUP3	x
Turn Off Speed	SERVICE	EQUIPMENT SERVICE	SETUP3	x
Turn On Lift	SERVICE	EQUIPMENT SERVICE	SETUP3	x
Turn On Speed	SERVICE	EQUIPMENT SERVICE	SETUP3	x
Vap. Heater Turn Off Lift	SERVICE	EQUIPMENT SERVICE	SETUP3	x
Vap. Heater Turn Off Speed	SERVICE	EQUIPMENT SERVICE	SETUP3	x
Vap. Heater Turn On Lift	SERVICE	EQUIPMENT SERVICE	SETUP3	x
Vap. Heater Turn On Speed	SERVICE	EQUIPMENT SERVICE	SETUP3	x
Vaporizer Heater	STATUS		COMPRESS	
Vaporizer Heater Mode	SERVICE	EQUIPMENT SERVICE	SETUP2	x
Vaporizer Heater Mode	SERVICE	EQUIPMENT SERVICE	SETUP3	x
Vaporizer Temp	STATUS		MAINSTAT	
Vaporizer Temp	STATUS		COMPRESS	
Vaporizer Temp	STATUS		HEAT_EX	
VFD Checksum Error	STATUS		VFD_STAT	
VFD Cold Plate Temp	STATUS		POWER	

APPENDIX A — ICVC PARAMETER INDEX (cont)

PARAMETER	MENU SOFTKEY	TABLE	SCREEN NAME	CONFIGURABLE
VFD Cold Plate Temp	SERVICE	CONTROL ALGORITHM STATUS	VFD_HIST	
VFD Comm Fault	STATUS		VFD_STAT	
VFD Coolant Flow	STATUS		HEAT_EX	
VFD Coolant Flow	STATUS		POWER	
VFD Delta	STATUS		COMPRESS	
VFD Delta	SERVICE	CONTROL ALGORITHM STATUS	CAPACITY	
VFD Dewpoint	STATUS		POWER	
VFD Dewpoint	SERVICE	CONTROL ALGORITHM STATUS	VFD_HIST	
VFD Enclosure Temp	STATUS		POWER	
VFD Enclosure temp	SERVICE	CONTROL ALGORITHM STATUS	VFD_HIST	
VFD Fault	STATUS		VFD_STAT	
VFD Fault Code	STATUS		VFD_STAT	
VFD Fault Code	SERVICE	CONTROL ALGORITHM STATUS	VFD_HIST	
VFD Gain	SERVICE	CONTROL ALGORITHM STATUS	CAPACITY	
VFD Gain	SERVICE	EQUIPMENT SERVICE	SETUP2	x
VFD Gateway Version #	STATUS		VFD_STAT	
VFD Inverter Version #	STATUS		VFD_STAT	
VFD Maximum Speed	SERVICE	EQUIPMENT SERVICE	SETUP2	x
VFD Minimum Speed	SERVICE	EQUIPMENT SERVICE	SETUP2	x
VFD Overload Decrease	SERVICE	EQUIPMENT SERVICE	RAMP_DEM	x
VFD Overload Delta	SERVICE	EQUIPMENT SERVICE	RAMP_DEM	x
VFD Power On Reset	STATUS		VFD_STAT	
VFD Rectifier Version #	STATUS		VFD_STAT	
VFD Speed Output	STATUS		MAINSTAT	
VFD Speed Output	STATUS		COMPRESS	
VFD Speed Output	SERVICE	CONTROL ALGORITHM STATUS	CAPACITY	
VFD Speed Output	STATUS	ECON_EXV	VFD_OUT	
VFD Start	STATUS		MAINSTAT	
VFD Start Inhibit	STATUS		VFD_STAT	
WSM Active?	SERVICE	CONTROL ALGORITHM STATUS	WSMCHLRE	

APPENDIX B — MAINTENANCE SUMMARY AND LOG SHEETS

NOTE: Always check the Optional Extended Warranty for specific maintenance requirements pertaining to that warranty.

23XRV Maintenance Interval Requirements

WEEKLY			
COMPRESSOR	Check Oil Level.	CONTROLS	Review ICVC Alarm/Alert History.
COOLER	None.	STARTER	None.
CONDENSER	None.	OIL RECLAIM	None.
MONTHLY			
COMPRESSOR	None.	CONTROLS	Perform an Automated Controls test.
COOLER	None.	STARTER	None.
CONDENSER	None.	OIL RECLAIM	None.
FIRST YEAR			
COMPRESSOR	Send oil sample out for analysis. Leak test. Inspect inlet bearing oil orifice. (Orifice should be inspected whenever oil line is removed.) Change motor cooling line filter-drier.	CONTROLS	Perform general cleaning. Tighten connections. Check pressure transducers against a gage. Recalibrate if necessary. Confirm accuracy of thermistors.
COOLER	Inspect and clean cooler tubes. Inspect relief valves. Leak test. Verify water pressure differential. Inspect water pumps and cooling tower. Perform eddy current test.	STARTER	Perform general cleaning. Tighten connections. Change VFD refrigerant strainer.
CONDENSER	Replace refrigerant filter/drier. Inspect and clean condenser tubes. Inspect relief valves. Leak test. Verify water pressure differential. Inspect water pumps and cooling tower. Perform eddy current test.	OIL RECLAIM	Inspect oil sump strainer.
ANNUALLY			
COMPRESSOR	Send oil sample out for analysis. Leak test. Perform vibration analysis. Meg-ohm test motor.	CONTROLS	Perform general cleaning. Tighten connections. Check pressure transducers against a gage. Recalibrate if necessary. Confirm accuracy of thermistors.
COOLER	Inspect and clean cooler tubes. Inspect relief valves. Leak test. Verify water pressure differential. Inspect water pumps and cooling tower.	STARTER	Perform general cleaning. Tighten connections. Change VFD refrigerant strainer.
CONDENSER	Inspect and clean condenser tubes. Inspect relief valves. Leak test. Verify water pressure differential. Inspect water pumps and cooling tower.	OIL RECLAIM	None.
EVERY 2 YEARS			
COMPRESSOR	Change oil filter, change motor cooling filter-drier.		
EVERY 3-5 YEARS			
COMPRESSOR	None.	CONTROLS	None.
COOLER	Eddy current tube test.	STARTER	None.
CONDENSER	Inspect float valve and strainer. Eddy current tube test.	OIL RECLAIM	Inspect oil sump strainer. Inspect oil sump heater.
EVERY 10 YEARS			
COMPRESSOR	Change oil charge if yearly analysis not completed. Inspect compressor rotors (every 5-10 years).	CONTROLS	None.
COOLER	Perform eddy current test (every 5-10 years). Cooler tube cleaning.	STARTER	None.
CONDENSER	Perform eddy current test. Condenser tube cleaning.	OIL RECLAIM	None.
SEASONAL SHUTDOWN			
COMPRESSOR	None.	CONTROLS	Do not disconnect control power.
COOLER	Isolate and drain waterbox. Remove waterbox cover from one end. Use compressed air to clear tubes.	STARTER	None.
CONDENSER	Isolate and drain waterbox. Remove waterbox cover from one end. Use compressed air to clear tubes.	OIL RECLAIM	None.

NOTE: Equipment failures caused by lack of adherence to the Maintenance Interval Requirements are not covered under warranty.

APPENDIX B — MAINTENANCE SUMMARY AND LOG SHEETS (cont)
23XRV Maintenance Log for Monthly, Quarterly, and Annual Checks

MONTH	1	2	3	4	5	6	7	8	9	10	11	12
DATE	/ /	/ /	/ /	/ /	/ /	/ /	/ /	/ /	/ /	/ /	/ /	/ /
OPERATOR												
UNIT SECTION	ENTRY											
ACTION	UNIT											
COMPRESSOR	Change Oil Charge	yes/no										
	Record Oil Temperature	°F										
	Send Oil Sample Out for Analysis	yes/no										
	Perform Vibration Analysis	yes/no										
COOLER	Leak Test	ppm										
	Inspect and Clean Cooler Tubes	yes/no										
	Inspect Relief Valves	yes/no										
	Leak Test	PPM										
CONDENSER	Record Water Pressure Differential	PSI										
	Record Cooler Pressure	PSI										
	Record Entering and Leaving Water Temperature	°F										
	Inspect Water Pumps	yes/no										
CONTROLS	Leak Test	PPM										
	Inspect and Clean Condenser Tubes	yes/no										
	Record Water Pressure Differential (PSI)	PSI										
	Record Cooler Pressure	PSI										
STARTER	Record Entering and Leaving Water Temperature	°F										
	Inspect Water Pumps and Cooling Tower	yes/no										
	Inspect Relief Valves	yes/no										
	Replace Refrigerant Filter Drier	yes/no										
CONTROLS	Inspect Float Valve and Strainer	yes/no										
	General Cleaning and Tightening Connections	yes/no										
	Confirm Accuracy of Pressure Transducers	yes/no										
	Confirm Accuracy of Thermistors	yes/no										
STARTER	Perform Automated Controls Test	yes/no										
	General Tightening and Cleaning Connections	yes/no										
	Change VFD Refrigerant Strainer	yes/no										

NOTE: Equipment failures caused by lack of adherence to the Maintenance Interval Requirements are not covered under warranty.

Annually

APPENDIX B — MAINTENANCE SUMMARY AND LOG SHEETS (cont)

23XRV Seasonal Shutdown Log

MONTH	1	2	3	4	5	6	7	8	9	10	11	12
DATE	/ /	/ /	/ /	/ /	/ /	/ /	/ /	/ /	/ /	/ /	/ /	/ /
OPERATOR												
UNIT SECTION	ENTRY											
COOLER	Isolate and Drain Waterbox											
	Remove Waterbox Cover from One End											
	Use Compressed Air to Clean Tubes											
CONDENSER	Isolate and Drain Waterbox											
	Remove Waterbox Cover from One End											
	Use Compressed Air to Clean Tubes											
CONTROLS	Do Not Disconnect Control Power											

NOTE: Equipment failures caused by lack of adherence to the Maintenance Interval Requirements are not covered under warranty.

APPENDIX C — BACNET COMMUNICATION OPTION

The following section is used to configure the UPC Open controller which is used when the BACnet* communication option is selected. The UPC Open controller is mounted in a separate enclosure below the main control box.

TO ADDRESS THE UPC OPEN CONTROLLER — The user must give the UPC Open controller an address that is unique on the BACnet network. Perform the following procedure to assign an address:

1. If the UPC Open controller is powered, pull the screw terminal connector from the controller's power terminals labeled Gnd and HOT. The controller reads the address each time power is applied to it.
2. Using the rotary switches (see Fig. A and B), set the controller's address. Set the Tens (10's) switch to the tens digit of the address, and set the Ones (1's) switch to the ones digit.

As an example in Fig. A, if the controller's address is 25, point the arrow on the Tens (10's) switch to 2 and the arrow on the Ones (1's) switch to 5.

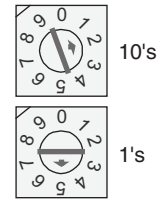

Fig. A — Address Rotary Switches

BACNET DEVICE INSTANCE ADDRESS — The UPC Open controller also has a BACnet Device Instance address. This Device Instance **MUST** be unique for the complete BACnet system in which the UPC Open controller is installed. The Device Instance is auto generated by default and is derived by adding the MAC address to the end of the Network Number. The Network Number of a new UPC Open controller is 16101, but it can be changed using i-Vu® Tools or BACView device. By default, a MAC address of 20 will result in a Device Instance of 16101 + 20 which would be a Device Instance of 1610120.

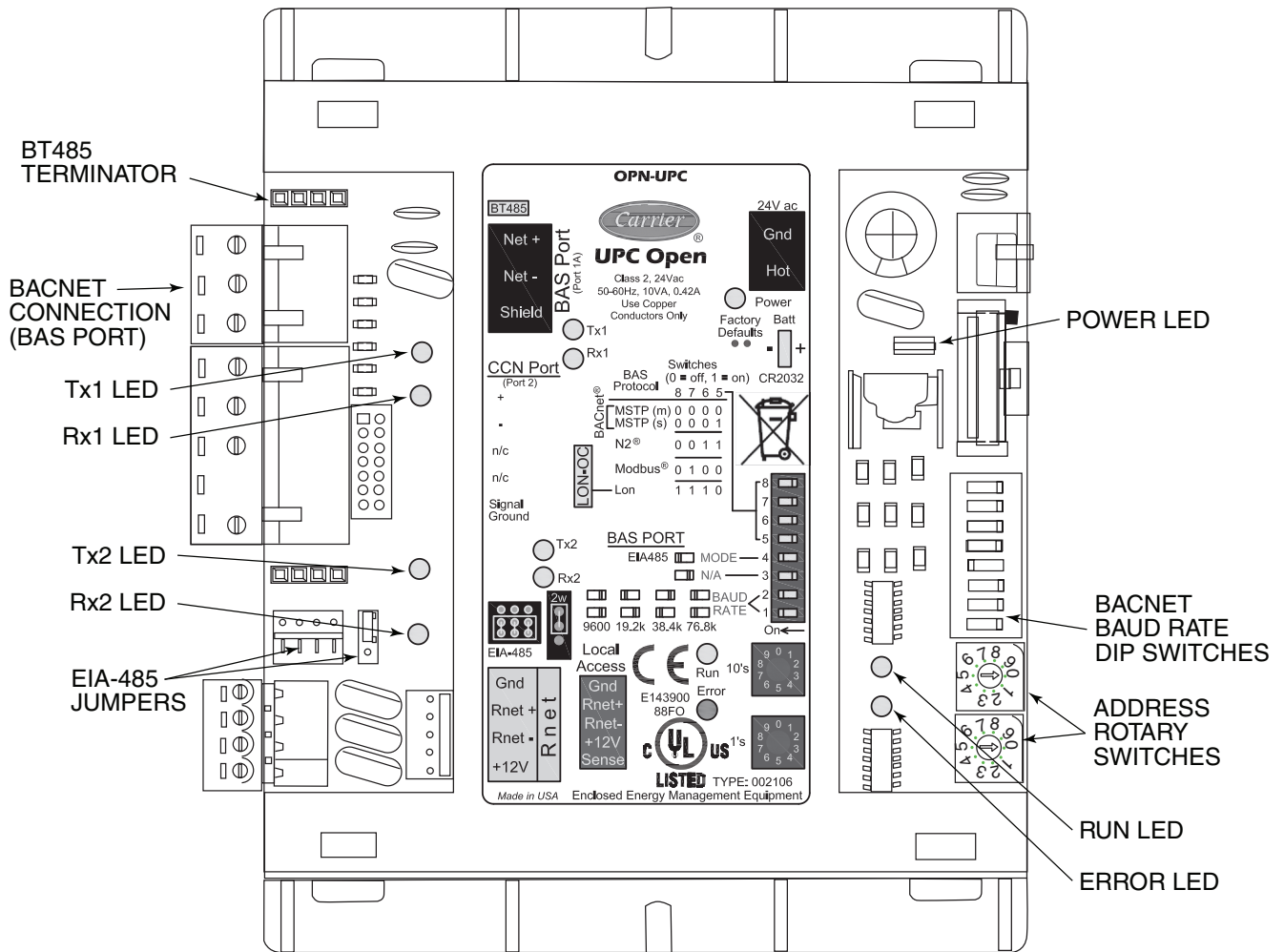

Fig. B — UPC Open Controller

* BACnet is a registered trademark of ASHRAE (American Society of Heating, Refrigerating and Air-Conditioning Engineers).

APPENDIX C — BACNET COMMUNICATION OPTION (cont)

CONFIGURING THE BAS PORT FOR BACNET MS/TP — Use the same baud rate and communication settings for all controllers on the network segment. The UPC Open controller is fixed at 8 data bits, No Parity, and 1 Stop bit for this protocol's communications.

If the UPC Open controller has been wired for power, pull the screw terminal connector from the controller's power terminals labeled Gnd and HOT. The controller reads the DIP Switches and jumpers each time power is applied to it.

Set the BAS Port DIP switch DS3 to “enable.” Set the BAS Port DIP switch DS4 to “E1-485.” Set the BMS Protocol DIP switches DS8 through DS5 to “MSTP.” See Table A.

Table A — SW3 Protocol Switch Settings for MS/TP

DS8	DS7	DS6	DS5	DS4	DS3
Off	Off	Off	Off	On	Off

Verify that the EIA-485 jumpers below the CCN Port are set to EIA-485 and 2W.

The example in Fig. C shows the BAS Port DIP Switches set for 76.8k (Carrier default) and MS/TP.

Set the BAS Port DIP Switches DS2 and DS1 for the appropriate communications speed of the MS/TP network (9600, 19.2k, 38.4k, or 76.8k bps). See Fig. C and Table B.

Table B — Baud Selection Table

BAUD RATE	DS2	DS1
9,600	Off	Off
19,200	On	Off
38,400	Off	On
76,800	On	On

WIRING THE UPC OPEN CONTROLLER TO THE MS/TP NETWORK — The UPC Open controller communicates using BACnet on an MS/TP network segment communications at 9600 bps, 19.2 kbps, 38.4 kbps, or 76.8 kbps.

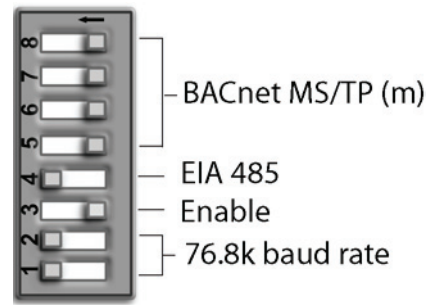

Fig. C — DIP Switches

Wire the controllers on an MS/TP network segment in a daisy-chain configuration. Wire specifications for the cable are 22 AWG (American Wire Gage) or 24 AWG, low-capacitance, twisted, stranded, shielded copper wire. The maximum length is 2000 ft.

Install a BT485 terminator on the first and last controller on a network segment to add bias and prevent signal distortions due to echoing. See Fig. B, D, and E.

To wire the UPC Open controller to the BAS network:

1. Pull the screw terminal connector from the controller's BAS Port.
2. Check the communications wiring for shorts and grounds.
3. Connect the communications wiring to the BAS port's screw terminals labeled Net +, Net -, and Shield.

NOTE: Use the same polarity throughout the network segment.

4. Insert the power screw terminal connector into the UPC Open controller's power terminals if they are not currently connected.
5. Verify communication with the network by viewing a module status report. To perform a module status report using the BACview keypad/display unit, press and hold the “FN” key then press the “.” Key.

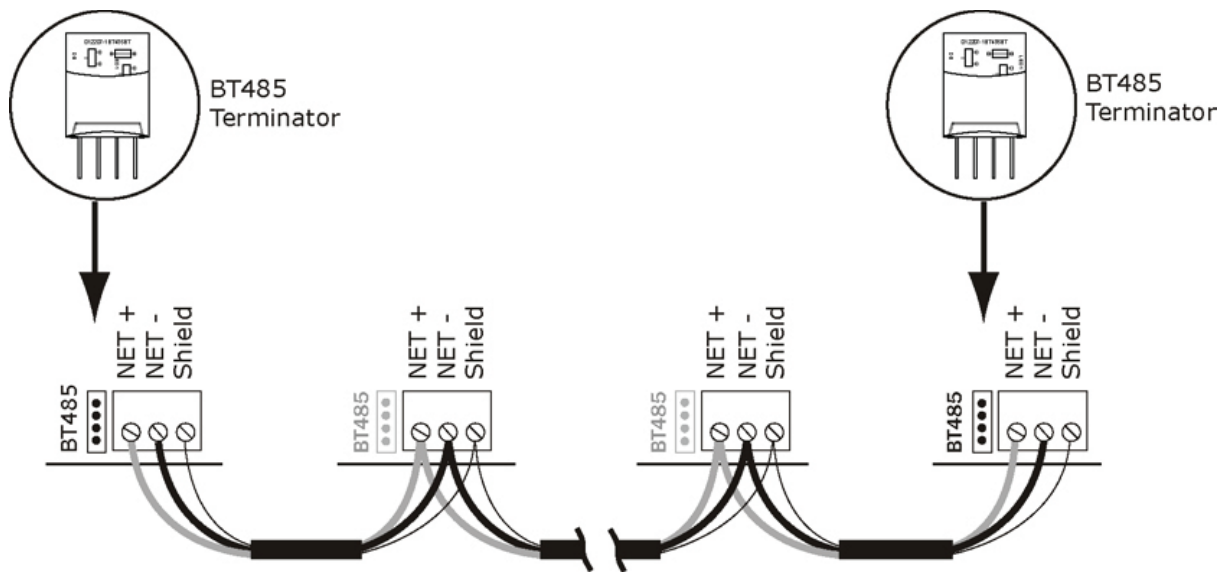

Fig. D — Network Wiring

APPENDIX C — BACNET COMMUNICATION OPTION (cont)

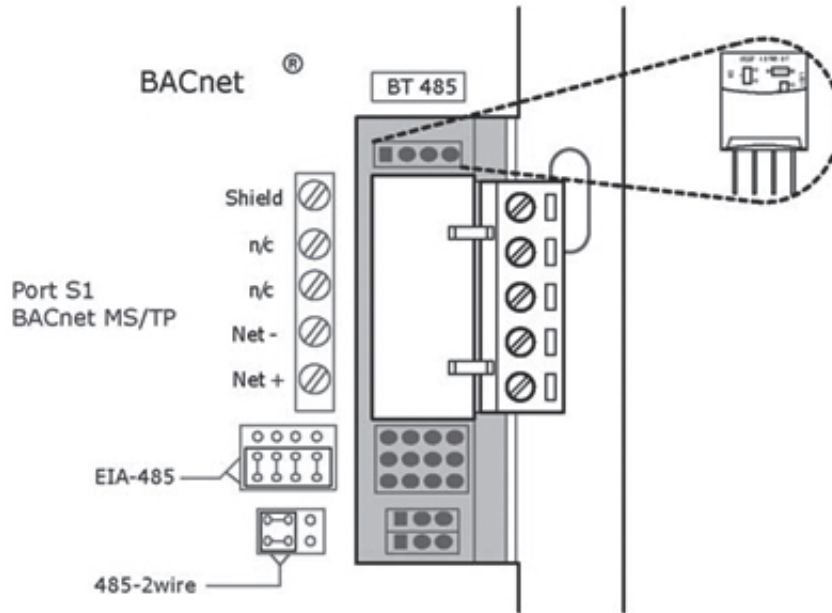

Fig. E — BT485 Terminator Installation

To install a BT485 terminator, push the BT485 terminator on to the BT485 connector located near the BACnet connector.

NOTE: The BT485 terminator has no polarity associated with it.

To order a BT485 terminator, consult Commercial Products i-Vu Open Control System Master Prices.

MS/TP WIRING RECOMMENDATIONS — Recommendations are shown in Tables C and D. The wire jacket and UL

temperature rating specifications list two acceptable alternatives. The Halar* specification has a higher temperature rating and a tougher outer jacket than the SmokeGard† specification, and it is appropriate for use in applications where the user is concerned about abrasion. The Halar jacket is also less likely to crack in extremely low temperatures.

NOTE: Use the specified type of wire and cable for maximum signal integrity.

Table C — MS/TP Wiring Recommendations

SPECIFICATION	RECOMMENDATION
CABLE	Single twisted pair, low capacitance, CL2P, 22 AWG (7x30), TC foam FEP, plenum rated cable
CONDUCTOR	22 or 24 AWG stranded copper (tin plated)
INSULATION	Foamed FEP 0.015 in. (0.381 mm) wall 0.060 in. (1.524 mm) O.D.
COLOR CODE	Black/White
TWIST LAY	2 in. (50.8 mm) lay on pair 6 twists/foot (20 twists/meter) nominal
SHIELDING	Aluminum/Mylar shield with 24 AWG TC drain wire
JACKET	SmokeGard Jacket (SmokeGard PVC) 0.021 in. (0.5334 mm) wall 0.175 in. (4.445 mm) O.D. Halar Jacket (E-CTFE) 0.010 in. (0.254 mm) wall 0.144 in. (3.6576 mm) O.D.
DC RESISTANCE	15.2 Ohms/1000 feet (50 Ohms/km) nominal
CAPACITANCE	12.5 pF/ft (41 pF/meter) nominal conductor to conductor
CHARACTERISTIC IMPEDANCE	100 Ohms nominal
WEIGHT	12 lb/1000 feet (17.9 kg/km)
UL TEMPERATURE RATING	SmokeGard 167 F (75 C) Halar -40 to 302 F (-40 to 150 C)
VOLTAGE	300 Vac, power limited
LISTING	UL: NEC CL2P, or better

LEGEND

- AWG** — American Wire Gage
- CL2P** — Class 2 Plenum Cable
- DC** — Direct Current
- FEP** — Fluorinated Ethylene Polymer
- NEC** — National Electrical Code
- O.D.** — Outside Diameter
- TC** — Tinned Copper
- UL** — Underwriters Laboratories

*Halar is a registered trademark of Solvay Plastics.
†SmokeGard is a trademark of AlphaGary-Mexichem Corp.

APPENDIX C — BACNET COMMUNICATION OPTION (cont)

Table D — Open System Wiring Specifications and Recommended Vendors

WIRING SPECIFICATIONS		RECOMMENDED VENDORS AND PART NUMBERS			
WIRE TYPE	DESCRIPTION	CONNECT AIR INTERNATIONAL	BELDEN	RMCORP	CONTRACTORS WIRE AND CABLE
MS/TP NETWORK (RS-485)	22 AWG, single twisted shielded pair, low capacitance, CL2P, TC foam FEP, plenum rated. See MS/TP Installation Guide for specifications.	W221P-22227	—	25160PV	CLP0520LC
	24 AWG, single twisted shielded pair, low capacitance, CL2P, TC foam FEP, plenum rated. See MS/TP Installation Guide for specifications.	W241P-2000F	82841	25120-OR	—
RNET	4 conductor, unshielded, CMP, 18 AWG, plenum rated.	W184C-2099BLB	6302UE	21450	CLP0442

LEGEND

- AWG** — American Wire Gage
- CL2P** — Class 2 Plenum Cable
- CMP** — Communications Plenum Rated
- FEP** — Fluorinated Ethylene Polymer
- TC** — Tinned Copper

LOCAL ACCESS TO THE UPC OPEN CONTROLLER — The user can use a BACview⁶ handheld keypad display unit or the Virtual BACview* software as a local user interface to an Open controller. These items let the user access the controller network information. These are accessory items and do not come with the UPC Open controller.

The BACview⁶ unit connects to the local access port on the UPC Open controller. See Fig. F. The BACview software must be running on a laptop computer that is connected to the local access port on the UPC Open controller. The laptop will require an additional USB link cable for connection.

See the *BACview Installation and User Guide* for instructions on connecting and using the BACview⁶ device.

To order a BACview⁶ Handheld (BV6H), consult Commercial Products i-Vu Open Control System Master Prices.

CONFIGURING THE UPC OPEN CONTROLLER'S PROPERTIES — The UPC Open device must be set to the same CCN Address (Element) number and CCN Bus number.

The factory default settings for CCN Element and CCN Bus number are 1 and 0 respectively.

If modifications to the default Element and Bus number are required, the UPC Open configuration must be changed.

The following configurations are used to set the CCN Address and Bus Number in the UPC Open controller. These configurations can be changed using the accessory BACview⁶ display.

- Navigation: BACview→CCN
- Home: Element Comm Stat
- Element: 1
- Bus: 0

TROUBLESHOOTING — If there are problems wiring or addressing the UPC Open controller, contact Carrier Technical Support.

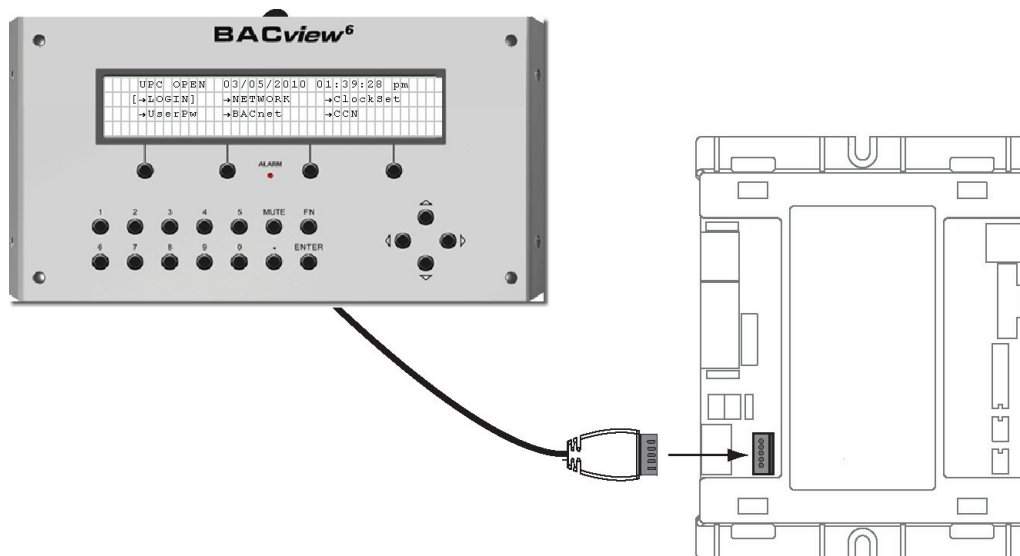

Fig. F — BACview⁶ Device Connection

*BACview is a registered trademark of Automated Logic Corporation.

APPENDIX C — BACNET COMMUNICATION OPTION (cont)

COMMUNICATION LEDES — The LEDs indicate if the controller is communicating with the devices on the network. See Tables E and F. The LEDs should reflect communication traffic based on the baud rate set. The higher the baud rate the more solid the LEDs become. See Fig. B for location of LEDs on UPC Open module.

REPLACING THE UPC OPEN BATTERY — The UPC Open controller's 10-year lithium CR2032 battery provides a minimum of 10,000 hours of data retention during power outages.

IMPORTANT: Power must be **ON** to the UPC Open when replacing the battery, or the date, time, and trend data will be lost.

Remove the battery from the controller, making note of the battery's polarity. Insert the new battery, matching the battery's polarity with the polarity indicated on the UPC Open controller.

NETWORK POINTS LIST — The points list for the controller is shown in Table G.

Table E — LED Status Indicators

LED	STATUS
POWER	Lights when power is being supplied to the controller. The UPC Open controller is protected by internal solid-state polyswitches on the incoming power and network connections. These polyswitches are not replaceable and will reset themselves if the condition that caused the fault returns to normal.
RX	Lights when the controller receives data from the network segment; there is an Rx LED for Ports 1 and 2.
TX	Lights when the controller transmits data to the network segment; there is an Tx LED for Ports 1 and 2.
RUN	Lights based on controller status. See Table F.
ERROR	Lights based on controller status. See Table F.

Table F — Run and Error LEDs Controller and Network Status Indication

RUN LED	ERROR LED	STATUS
2 flashes per second	Off	Normal
	2 flashes, alternating with Run LED	Five minute auto-restart delay after system error
	3 flashes, then off	Controller has just been formatted
	1 flash per second	Controller is alone on the network
5 flashes per second	On	Exec halted after frequent system errors or control programs halted
	On	Exec start-up aborted, Boot is running
	Off	Firmware transfer in progress, Boot is running
7 flashes per second	7 flashes per second, alternating with Run LED	Ten-second recovery period after brownout
14 flashes per second	14 flashes per second, alternating with Run LED	Brownout

APPENDIX C — BACNET COMMUNICATION OPTION (cont)

Table G — Network Points List

POINT DESCRIPTION	CCN POINT NAME	READ/ WRITE	UNITS	DEFAULT VALUE	RANGE	BACNET OBJECT ID	BACNET OBJECT NAME
Active Delta T	DT_A_	R	psi	N/A	0 to 200	AV:4	dt_a_1
Active Demand Limit	DEM_LIM	R/W	%	N/A	40 to 100	AV:5	dem_lim_1
Actual VFD Speed	VFD_ACT	R	%	N/A	0 to 110	AV:6	vfd_act_1
Auto Chilled Liq Reset	AUTO_RES	R	mA	N/A	4 to 20	AV:7	auto_res_1
Auto Demand Limit Input	AUTO_DEM	R	mA	N/A	4 to 20	AV:8	auto_dem_1
Base Demand Limit	DLM	R/W	%	N/A	40 to 100	AV:9	dlim_1
Calc Evap Sat Temp	ERT	R	°F	N/A	-40 to 245	AV:10	ert_1
Chill Liq Pulldown/Min	CHL_PULL	R/W	°F	N/A	-20 to 20	AV:13	chl_pull_1
Chilled Liquid Temp	CHL_TMP	R	°F	N/A	-40 to 245	AV:11	chl_tmp_1
Chilled Water Temp	CHWTEMP	R	°F	N/A	0.0 to 99.9	AV:12	chwtemp_1
Chiller Start/Stop	CHIL_S_S	R/W		N/A	STOP/START	BV:5	chil_s_s_1
Comp Discharge Alert	CD_ALERT	R	°F	140	125 to 160	AV:14	cd_alert_1
Comp Discharge Temp	CMPD	R	°F	N/A	-40 to 245	AV:15	cmpd_1
Comp Motor Frequency	VFD_FREQ	R	Hz	N/A	0 to 10000	AV:49	vfd_freq_1
Comp Motor RPM	CPR_RPM	R	rpm	N/A	0 to 300000	AV:50	cpr_rpm_1
Condenser Liquid Pump	CDP			N/A	OFF/ON	BV:4	cdp_1
Condenser Pressure	CRP	R	psi	N/A	-6.7 to 420	AV:16	crp_1
Condenser Refrig Temp	CRT	R	°F	N/A	-40 to 245	AV:17	crt_1
Control Mode	MODE	R		N/A	0=Off, 1=Local , 2=CCN, 3=Reset	AV:51	mode_1
Control Point	LCW_STPT	R/W	°F	N/A	10 to 65	AV:18	lcw_stpt_1
Current CHW Setpoint	CHWSTPT	R	°F	N/A	0.0 to 99.9	AV:19	chwstpt_1
Demand Level 1		R	%	N/A	0 to 100	AV:1	dmv_lvl_1_perct_1
Demand Level 2		R	%	N/A	0 to 100	AV:2	dmv_lvl_2_perct_1
Demand Level 3		R	%	N/A	0 to 100	AV:3	dmv_lvl_3_perct_1
Element Communications Alarm		R		N/A	Comm Normal Comm Lost	BV:15	comm_lost_alm_1
Element Comm Status		R		N/A	No Comm/Normal	BV:2999	element_stat_1
Entering Chilled Liquid	ECL	R	°F	N/A	-40 to 245	AV:20	ecl_1
Entering Cond Liquid	ECDL	R	°F	N/A	-40 to 245	AV:21	ecd_1
Evap Refrig Liquid Temp	EST	R	°F	N/A	-40 to 245	AV:23	est_1
Evap Refrig Trippoint	ERT_TRIP	R	°F	33	10 to 40.0	AV:24	ert_trip_1
Evaporator Pressure	ERP	R	psi	N/A	-6.7 to 420	AV:22	erp_1
Ground Fault Current	GF_AMPS	R	A	N/A	0 to 999	AV:25	gf_amps_1
Head Pressure Reference	HPR	R	%	N/A	0 to 100	AV:52	hpr_1
Leaving Chilled Liquid - Prime Variable	LCL	R	°F	N/A	-40 to 245	AV:26	lcl_1
Leaving Cond Liquid	LCDL	R	°F	N/A	-40 to 245	AV:27	lcdl_1
Local Schedule		R		N/A	ON/OFF	BV:1	schedule_1
Occupied?	OCC	R			NO/YES	BV:6	occ_1
Oil Heater Relay 1	OILHEAT1	R		N/A	OFF/ON	BV:7	oilheat1_1
Oil Heater Relay 2	OILHEAT2	R		N/A	OFF/ON	BV:11	oilheat2_1
Oil Pump Relay	OILR	R		N/A	OFF/ON	BV:8	oilr_1
Oil Pressure Delta P	OILPD	R	psi	N/A	-6.7 to 420	AV:28	oilpd_1
Oil Sump Temp	OILT	R	°F	N/A	-40 to 245	AV:29	oilt_1
Percent Line Current	LNAMPS_P	R	%	N/A	0.0 to 9999	AV:30	lnamps_p_1
Percent Line Kilowatts	LINEKW_P	R	%	N/A	0.0 to 9999	AV:31	linekw_p_1

LEGEND

CHW — Chilled Water
R — Read
VFD — Variable Frequency Drive
W — Write

APPENDIX C — BACNET COMMUNICATION OPTION (cont)

Table G — Network Points List (cont)

POINT DESCRIPTION	CCN POINT NAME	READ/ WRITE	UNITS	DEFAULT VALUE	RANGE	BACNET OBJECT ID	BACNET OBJECT NAME
Relative Humidity	HUMIDITY	R		N/A	0 to 100	AV:32	humidity_1
Remote Reset Sensor	R_RESET	R	°F	N/A	-40 to 245	AV:33	r_reset_1
Remote Start Contact	REM_CON	R/W		N/A	OPEN/CLOSE	BV:9	rem_con_1
Run Status	STATUS	R		N/A	1=Timeout, 2=Ready, 3=Recyle, 4=Startup, 5=Running, 6=Demand, 7=Ramping, 8=not used, 9=Override, 10=Tripout, 11=Control Test, 12=Lockout, 13=Pumpdown, 14=Prestart	AV:34	status_1
Service Ontime	S_HRS	R/W	hr	N/A	0 to 32767	AV:35	s_hrs_1
Shunt Trip Relay	TRIPR	R		N/A	OFF/ON	BV:17	tripr_1
Stall Protection Counts	SPC	R		N/A	0 to 5	AV:36	spc_1
Start Complete	START_OK	R		N/A	FALSE/TRUE	BV:18	start_ok_1
Stop Fault	AMPSTOP	R		N/A	NORMAL/ALARM	BV:10	ampstop_1
System Alert/Alarm	SYS_ALM	R		N/A	0=Normal 1=Alert 2=Alarm	AV:37	sys_alm_1
System Cooling Demand Level		R		N/A	N/A	AV:9006	cool_demand_level_1
System Demand Limiting		R		N/A	Active/Inactive	BV:2	dem_lmt_act_1
Target VFD Speed	VFD_TRG	R	%	N/A	0 to 100	AV:38	vfd_trg_1
Torque Current	TORQ_I	R	A	N/A	0 to 99999	AV:39	torq_i_1
Tower Fan Relay High	TFR_HIGH	R		N/A	OFF/ON	BV:19	tfr_2_1
Tower Fan Relay Low	TFR_LOW	R		N/A	OFF/ON	BV:20	tfr_1_1
User Defined Analog 1		R		N/A	N/A	AV:2901	user_analog_1_1
User Defined Analog 2		R		N/A	N/A	AV:2902	user_analog_2_1
User Defined Analog 3		R		N/A	N/A	AV:2903	user_analog_3_1
User Defined Analog 4		R		N/A	N/A	AV:2904	user_analog_4_1
User Defined Analog 5		R		N/A	N/A	AV:2905	user_analog_5_1
User Defined Binary 1		R		N/A		BV:2911	user_binary_1_1
User Defined Binary 2		R		N/A		BV:2912	user_binary_2_1
User Defined Binary 3		R		N/A		BV:2913	user_binary_3_1
User Defined Binary 4		R		N/A		BV:2914	user_binary_4_1
User Defined Binary 5		R		N/A		BV:2915	user_binary_5_1
Vaporizer Temp	VAP_TEMP	R	°F	N/A	-40 to 245	AV:45	vap_temp_1
VFD Cold Plate Temp	CP_TEMP	R	°F	N/A	0 to 300	AV:46	cp_temp_1
VFD Start	VFDSTART	R		N/A	NO/YES	BV:21	vfdstart_1

LEGEND

CHW — Chilled Water
R — Read
VFD — Variable Frequency Drive
W — Write

INDEX

- Abbreviations and explanations 5
- BACnet communication option 161-167
- Before initial start-up 62-81
- Carrier Comfort Network® Interface 75
- Carrier Comfort Network communication wiring 146
- Capacity control 18
- Capacity override 48
- Chilled liquid recycle mode 62
- Chiller control module (CCM) 123
- Chiller dehydration 71
- Chiller familiarization 5-13
- Chiller identification nameplate 5
- Chiller start-up (prepare for) 82,83
- Chillers with storage tanks 87
- Chiller tightness (check) 64
- Cold weather operation 84
- Compressor bearing maintenance 98
- Compressor inlet bearing oil orifice 96
- Compressor minimum speed override 48
- Compressor rotor check 98
- Condenser description 12
- Condenser freeze prevention 53
- Condenser pump control 53
- Control algorithms checkout procedure 102
- Control center
 - description 12
 - check before start-up 74
 - inspect 94, 99
- Control modules 123
- Controls 18-61
- Controls (definitions) 18
- Controls overview 18
- Controls schematics 134-138
- Control test 78, 102
- Cooler, description 12
- Default screen freeze 48
- Defective ICVC modules (replacing) 124
- Demand limit control option 54
- Design set points (input) 75
- Display messages (checking) 101
- Equipment required 62
- Extended shutdown (preparation for) 84
- Extended shutdown (after) 84
- Fast power source transfers 53
- Field wiring schematic 142-145
- Gateway status LEDs 125
- General maintenance 93, 94
- Ground fault troubleshooting 74
- Head pressure output reference 54
- Heat exchanger tubes (inspect) 99
- High altitude locations 79
- Hot gas bypass (optional) algorithm 54
- ICVC operation and menus 23
- ICVC parameter index 149-156
- Initial start-up checklist CL-1 to CL-10
- Input power wiring 73
- Instruct the customer operator 82
- Job data required 62
- Lead/lag control 56
- Lead/lag control wiring 147, 148
- Leak test chiller 64
- Limited shutdown, after 84
- Liquid piping, inspecting 71
- Liquid/brine temperature reset 53
- Local occupied schedule (input) 75
- Local start-up 60
- Lubrication cycle 16-18
- Lubrication cycle (details) 16
- Lubrication cycle (summary) 16
- Lubrication system (check) 94
- Maintenance log 157-160
- Module operation (notes) 123
- Motor-compressor description 12
- Motor cooling cycle 16
- Motor insulation 98
- Muffler description 12
- Network device control, attaching to 58
- Oil and oil filter changes 94
- Oil charge 62
- Oil circuit valves (open) 62
- Oil heater 95
- Oil pressure and compressor stop (check) 82
- Oil reclaim system 17
- Oil specification 95
- Oil strainers 95
- Oil sump temperature control 48, 52
- Operating instructions 83-85
- Operating the optional pumpout unit 86
- Operator duties 83
- Optional flow device calibration 78
- Optional pumpout compressor liquid piping (check) 72
- Optional pumpout system controls and compressor (check) 79
- Optional pumpout system maintenance 99
- Optional storage tank and pumpout system (using) 62
- Ordering replacement chiller parts 100
- Overview (troubleshooting guide) 100
- Physical data 129
- PIC III system components 18
- PIC III system functions 46
- Preparation (pumpout and refrigerant transfer procedures) 86
- Pressure transducers 78, 99, 101
- Prevent accidental start-up 82
- Pumpout and refrigerant transfer procedures 86-93
- Ramp loading 48
- Refrigerant (adding) 93
- Refrigerant (adjusting the charge) 93
- Refrigerant charge (trim) 94
- Refrigerant filter/drier 95
- Refrigerant float system (inspect) 96
- Refrigerant into chiller (charge) 79
- Refrigerant leak detector 52
- Refrigerant leak rate 93
- Refrigerant leak testing 93
- Refrigerant properties 93
- Refrigerant (removing) 93
- Refrigerant tracer 64
- Refrigeration cycle 13-15
- Refrigeration log 84
- Relief valves (check) 72
- Relief valves and piping (inspect) 98
- Remote start/stop contacts 52
- Remote reset of alarms 52
- Repair the refrigerant leak retest and apply standing vacuum test 94
- Restart after power failure 53
- Running system (check) 83
- Safety and operating controls (check monthly) 94
- Safety considerations 1, 2
- Safety controls 47
- Safety shutdown 62
- Scheduled maintenance 94-100
- Service configurations (input) 75
- Service ontime 94
- Service operation 59
- Shipping packaging (remove) 62
- Shunt trip 48
- Shutdown sequence 61
- Soft stop amps threshold, automatic 61
- Software configuration 75
- Spare alarm contacts 52
- Spare safety inputs 52
- Spare temperature inputs 52
- Start the chiller 83
- Start-up, initial 82, 85
- Start-up, initial preparation 82
- Start-up/shutdown/recycle sequence 60-62
- Stop the chiller 83
- Storage vessel (optional) description 12
- System components 5
- Temperature sensors (checking) 101
- Test after service, repair or major leak 94
- Tighten all gasketed joints 63
- Tower fan relay low and high 53
- Troubleshooting guide 100-148
- Vaporizer refrigerant return line orifice 96
- Vaporizer temperature control 48
- VFD, identify 72
- VFD refrigerant strainer 96
- VFD schematic 139-145
- Water/brine leaks 99
- Water/brine treatment 99
- Weekly maintenance 94
- Wiring, inspecting 74
- Wiring schematics
 - CCN communication wiring 146
 - Controls 134-138
 - Field wiring 142-145
 - Lead/lag control wiring 147, 148
 - VFD schematics 139-145

**INITIAL START-UP CHECKLIST
FOR 23XRV VARIABLE SPEED SCREW CHILLER WITH GREENSPEED® INTELLIGENCE
(Remove and use for job file.)**

NOTE: To avoid injury to personnel and damage to equipment or property when completing the procedures listed in this start-up checklist, use good judgment, follow safe practices, and adhere to the safety considerations/information as outlined in preceding sections of this Controls, Start-Up, Operation, Maintenance Instructions document.

MACHINE INFORMATION:

JOB NAME _____ EQUIPMENT TAG / MARK FOR _____
 JOB ADDRESS _____ JOB NO. _____
 CITY _____ STATE _____ MODEL _____
 ZIP _____ S/N _____

DESIGN CONDITIONS

	TONS (kW)	BRINE	FLOW RATE	TEMPERATURE IN	TEMPERATURE OUT	PRESSURE DROP	PASS	SUCTION TEMPERATURE	CONDENSER TEMPERATURE
COOLER									*****
CONDENSER								*****	

From Chiller Nameplate: Line Voltage _____ Rated Line Amps _____ Overload Trip Amps _____
 From VFD Nameplate: I.D. No.: _____ Input Rating _____
 VFD Serial Number _____
 Mfd in _____ on _____

REFRIGERANT: Type: _____ Charge _____

CARRIER OBLIGATIONS: Assemble. Yes No
 Leak Test Yes No
 Dehydrate Yes No
 Charging Yes No
 Operating Instructions _____ Hrs.

START-UP TO BE PERFORMED IN ACCORDANCE WITH APPROPRIATE MACHINE START-UP INSTRUCTIONS
 JOB DATA REQUIRED:

1. Machine Installation Instructions Yes No
2. Machine Assembly, Wiring and Piping Diagrams Yes No
3. Starting Equipment Details and Wiring Diagrams Yes No
4. Applicable Design Data (see above). Yes No
5. Diagrams and Instructions for Special Controls Yes No

INITIAL MACHINE PRESSURE: _____

	YES	NO
Was Machine Tight?		
If Not, Were Leaks Corrected?		
Was Machine Dehydrated After Repairs?		

CHECK OIL LEVEL AND RECORD:

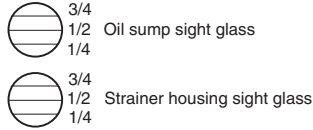

ADD OIL: Yes No

Amount: _____

RECORD PRESSURE DROPS: Cooler _____

Condenser _____

CHARGE REFRIGERANT: Initial Charge _____

Final Charge After Trim _____

INSPECT WIRING AND RECORD ELECTRICAL DATA:

Verify 6" clearance surrounding all Control Center louvers Yes No

Visually inspect down through top of power module for debris Yes No

RATINGS:

Motor Voltage _____ Motor(s) Amps _____ Oil Pump Voltage _____ Starter LRA Rating _____

Line Voltages: Motor _____ Oil Pump _____ Controls/Oil Heater _____

RECORD THE FOLLOWING POWER ON CHECKS:

Line Voltage: Phase - Phase	A-B:	B-C:	A-C:
Line Voltage: Phase - Ground	A-G:	B-G:	C-G:

What type and size of transformer supplies power to the unit?

Delta with No Ground _____

Corner Grounded Delta _____

Wye with Center Ground _____

Wye with No Ground _____

Transformer Size _____ kVa

FIELD-DISASSEMBLED CHILLERS ONLY:

Megger Test Motor if the VFD is removed from the chiller.

Check continuity T1 to T1, etc. (Motor to starter, disconnect motor leads T1, T2, T3.) Do not megger VFD; disconnect leads to motor and megger the leads.

MEGGER MOTOR	"PHASE TO PHASE"			"PHASE TO GROUND"		
	T1-T2	T1-T3	T2-T3	T1-G	T2-G	T3-G
10-Second Readings:						
60-Second Readings:						
Polarization Ratio:						

CONTROLS: SAFETY, OPERATING, ETC.

Verify parameters in VFD_conf screen. Yes No

Perform Controls Test Yes No

PIC III CAUTION
 COMPRESSOR MOTOR AND CONTROL CENTER **MUST** BE PROPERLY AND INDIVIDUALLY CONNECTED BACK TO THE EARTH GROUND IN THE STARTER (IN ACCORDANCE WITH CERTIFIED DRAWINGS).

Yes _____

Water/Brine Pump Control

Can the Carrier controls independently start the pumps?

Condenser Liquid Pump Yes No
 Chilled Liquid Pump Yes No

CUT ALONG DOTTED LINE

INITIAL START:

Check Position of all Valves: _____

Isolation Valves (See Fig. 2-4, 41-43, and 45)

VALVE	LOCATION	OPEN
Discharge	Under Muffler	_____
Cooler Inlet	Next to economizer or under cooler	_____
Hot Gas Bypass	Between cooler and condenser	_____
Vaporizer Condenser Gas	Between cooler and condenser	_____
Oil Pump	Next to oil pump inlet	_____
Oil Filter	Downstream of oil filter	_____
Oil Pressure Regulator	Under oil sump next to oil pressure regulator	_____
Filter/Drier	Next to condenser float chamber	_____
Filter/Drier	Under condenser near filter/drier	_____
VFD Refrigerant Cooling Inlet	Under compressor discharge	_____
VFD Refrigerant Cooling Drain	Between cooler and condenser	_____

Relief Valve Three-Way Valves

Cooler (if installed)	Fully Front Seated or Fully Back Seated	_____
Condenser	Fully Front Seated or Fully Back Seated	_____

Service Valves

VALVE	LOCATION	CLOSED
Cooler Refrigerant Charging Valve	On cooler relief valve tree	_____
Cooler Refrigerant Pumpout Valve	Under cooler	_____
Condenser Refrigerant Charging Valve	On condenser relief valve tree	_____
Condenser Refrigerant Pumpout Valve	On condenser float valve chamber	_____
Oil Sump Charging/Drain Valve	Under oil sump	_____

Start Liquid Pumps and Establish Liquid Flow _____

Oil Level OK and Oil Temperature OK _____ Oil Pressure _____

Restart Compressor, Bring Up To Speed. Shut Down. Any Abnormal Coastdown Noise? Yes* No

*If yes, determine cause.

START MACHINE AND OPERATE. COMPLETE THE FOLLOWING:

- A: Trim charge and record under Charge Refrigerant Into Chiller section on page 79.
- B: Inspect refrigerant cooling lines for condensation (Q,R compressors only). See page 71.
- B: Complete any remaining control calibration and record under Controls section (pages 18-61).
- C: Take at least two sets of operational log readings and record.
- D: After machine has been successfully run and set up, shut down and mark shutdown oil levels.
- E: Give operating instructions to owner's operating personnel. Hours Given: _____ Hours
- F: Call your Carrier factory representative to report chiller start-up.
- G: Rockwell/Allen Bradley VFD: Register drive start-up at www.automation.rockwell.com/warp.
Eaton VFD: Complete Eaton Warranty Registration Form TD08H28TE and send to:
VFDAftermarketEG@eaton.com
NOTE: To extend drive warranty, registration should be performed by a Rockwell or Eaton Certified Technician as applicable.
- H: Return a copy of this completed checklist to the local Carrier Service office.

SIGNATURES:

CARRIER
TECHNICIAN _____

CUSTOMER
REPRESENTATIVE _____

DATE _____

DATE _____

23XRV PIC III SETPOINT TABLE CONFIGURATION SHEET

DESCRIPTION	RANGE	UNITS	DEFAULT	VALUE
Base Demand Limit	40 to 100	%	100	
LCL Setpoint	10 to 60 (-12.2 to 15.6)	° F (° C)	50.0 (10.0)	
ECL Setpoint	15 to 65 (-9.4 to 18.3)	° F (° C)	60.0 (15.6)	
Ice Build Setpoint	15 to 60 (-9.4 to 15.6)	° F (° C)	40 (4.4)	
Tower Fan High Setpoint	55 to 105 (13 to 41)	° F (° C)	75 (23.9)	

Upload all Control Configuration tables via Service Tool Yes No

ICVC Software Part # (See ICVC CONFIGURATION Screen): _____

ICVC Controller Identification (See ICVC CONFIGURATION Screen): BUS: _____ ADDRESS: _____

VFD Gateway Version # (See VFD_STAT Screen): _____

VFD Inverter Version # (See VFD_STAT Screen): _____

VFD Rectifier Version # (See VFD_STAT Screen): _____

23XRV PIC III LOCAL TIME SCHEDULE CONFIGURATION SHEET OCCPC01S

	Day Flag								Occupied Time				Unoccupied Time			
	M	T	W	T	F	S	S	H								
Period 1:																
Period 2:																
Period 3:																
Period 4:																
Period 5:																
Period 6:																
Period 7:																
Period 8:																

NOTE: Default setting is OCCUPIED 24 hours/day.

ICE BUILD 23XRV PIC III TIME SCHEDULE CONFIGURATION SHEET OCCPC02S

	Day Flag								Occupied Time				Unoccupied Time			
	M	T	W	T	F	S	S	H								
Period 1:																
Period 2:																
Period 3:																
Period 4:																
Period 5:																
Period 6:																
Period 7:																
Period 8:																

NOTE: Default setting is UNOCCUPIED 24 hours/day.

CUT ALONG DOTTED LINE

23XRV PIC III CCN TIME SCHEDULE CONFIGURATION SHEET OCCPC03S

	Day Flag							Occupied Time				Unoccupied Time				
	M	T	W	T	F	S	S	H								
Period 1:																
Period 2:																
Period 3:																
Period 4:																
Period 5:																
Period 6:																
Period 7:																
Period 8:																

NOTE: Default setting is OCCUPIED 24 hours/day.

23XRV PIC III VFD_CONF TABLE CONFIGURATION SHEET

DESCRIPTION	RANGE	UNITS	DEFAULT	VALUE
Motor Nameplate Voltage	380 to 480	VOLTS	480	
Compressor 100% Speed	54 to 110 (Q,R Compressors) 54 to 140 (P Compressor)	Hz	70	
Rated Line Voltage	208 to 600	VOLTS	460	
Rated Line Amps	10 to 5000	AMPS	200	
Rated Line Kilowatts	0 to 999999	KW	100	
Motor Rated Load KW	0 to 999999	KW	100	
Motor Rated Load Amps	10 to 5000	AMPS	200	
Motor Nameplate Amps	10 to 5000	AMPS	100	
Motor Nameplate RPM	1500 to 3500 (Q,R Compressors) 1500 to 3960 (P Compressor)		2672 3750	
Motor Nameplate KW	0 to 999999	KW	100	
Inverter PWM Frequency (0=4 k Hz, 1=2 k Hz)	0/1		0	
Skip Frequency 1	0.0 to 102	Hz	102	
Skip Frequency 2	0.0 to 102	Hz	102	
Skip Frequency 3	0.0 to 102	Hz	102	
Skip Frequency Band	0.0 to 102	Hz	0	
Line Voltage % Imbalance	1 to 10	%	10	
Line Volt Imbalance Time	1 to 10	SEC	10	
Line Current % Imbalance	5 to 40	%	40	
Line Current Imbal Time	1 to 10	SEC	10	
Motor Current % Imbalance	5 to 40	%	40	
Motor Current Imbal Time	1 to 10	SEC	10	
Increase Ramp Time	5 to 60 (Q,R Compressors) 0 to 255 (P Compressor)	SEC	30	
Decrease Ramp Time	5 to 60 (Q,R Compressors) 5 to 255 (P Compressor)	SEC	30	
Single Cycle Dropout	0/1	DSABLE/ ENABLE	DSABLE	

23XRV PIC III OPTIONS TABLE CONFIGURATION SHEET

DESCRIPTION	RANGE	UNITS	DEFAULT	VALUE
Auto Restart Option	0/1	DSABLE/ENABLE	DSABLE	
Remote Contacts Option	0/1	DSABLE/ENABLE	DSABLE	
Soft Stop Amps Threshold	40 to 100	%	100	
Hot Gas Bypass				
HGBP Option	0,1,2	0=DSABLE 1=HGBP 2=LOW LOAD HGBP	DSABLE	
Min. Load Point (T1, P1)				
HGBP Delta T1	0.5 to 20 (.3 to 11.1)	^F (^C)	1.5 (.8)	
HGBP Delta P1	10 to 170 (68.9 to 1172.2)	PSI (kPa)	150 (1034.2)	
Full Load Point (T2, P2)				
HGBP Delta T2	0.5 to 20 (.3 to 11.1)	^F (^C)	4 (2.2)	
HGBP Delta P2	30 to 250 (206.9 to 1724)	PSI (kPa)	200 (1379)	
HGBP Deadband	0.5 to 3 (.3 to 1.7)	^F (^C)	1 (.6)	
HGBP On Delta Speed	0.0 to 20.0	%	5.0	
HGBP Off Delta Speed	0.0 to 20.0	%	3.0	
Stall Protection				
Stall Delta % Amps	5 to 20	%	10	
Stall Time Period	7 to 10	MIN	8	
Ice Build Control				
Ice Build Option	0/1	DSABLE/ENABLE	DSABLE	
Ice Build Termination (0=TEMP, 1=Contact, 2=Both)	0 to 2		0	
Ice Build Recycle	0/1	DSABLE/ENABLE	DSABLE	
Refrigerant Leak Option	0/1	DSABLE/ENABLE	DSABLE	
PPM at 20 mA	0 to 99999		1000	
Refrigerant Leak Alarm PPM	0 to 99999		500	
Head Pressure Reference				
Delta P at 0% (4 mA)	20 to 85 (138 to 586)	PSI (kPa)	25 (172)	
Delta P at 100% (20 mA)	20 to 85 (138 to 586)	PSI (kPa)	50 (345)	
Minimum Output	0 to 100	%	0	

CUT ALONG DOTTED LINE

CUT ALONG DOTTED LINE

23XRV PIC III SETUP1 TABLE CONFIGURATION SHEET

DESCRIPTION	RANGE	UNITS	DEFAULT	VALUE
Comp Motor Temp Override	150 to 200 (66 to 93)	° F (° C)	200 (93)	
Cond Press Override	145 to 166 (1000 to 1145)	PSI (kPa)	145 (1000)	
Comp Discharge Alert	125 to 160 (52 to 71)	° F (° C)	140 (60)	
Rectifier Temp Override, Q,R Compressors	155 to 170 (68 to 77)	° F (° C)	160 (71)	
Rectifier Temp Override, P Compressor	155 to 190 (68 to 88)	° F (° C)	180 (82)	
Inverter Temp Override, Q,R Compressors	155 to 170 (68 to 77)	° F (° C)	160 (71)	
Inverter Temp Override, P Compressor	155 to 190 (68 to 88)	° F (° C)	180 (82)	
Chilled Medium	0/1	WATER/BRINE	WATER	
Chilled Liquid Deadband	0.5 to 2.0 (0.3 to 1.1)	° F (° C)	1.0 (0.6)	
Evap Refrig Trippoint	10 to 40.0 (-12.2 to 4.4)	° F (° C)	33 (0.6)	
Refrig Override Delta T Q,R Compressors	2.0 to 5.0 (1.1 to 2.8)	° F (° C)	3 (1.7)	
Refrig Override Delta T P Compressor	2.0 to 10.0 (1.1 to 5.6)	° F (° C)	5 (2.8)	
Evap Approach Alert Q,R Compressors	0.5 to 30.0 (0.3 to 16.6)	° F (° C)	5 (2.8)	
Evap Approach Alert P Compressor	0.5 to 10.0 (0.3 to 5.6)	° F (° C)	4 (2.2)	
Cond Approach Alert	0.5 to 30.0 (0.3 to 16.6)	° F (° C)	6 (3.3)	
Condenser Freeze Point	-20 to 35 (-28.9 to 1.7)	° F (° C)	34 (1.1)	
Flow Delta P Display	0/1	DSABLE/ENABLE	DSABLE	
Evap Flow Delta P Cutout	0.5 to 50.0 (3.4 to 344.8)	PSI (kPa)	5.0 (34.5)	
Cond Flow Delta P Cutout	0.5 to 50.0 (3.4 to 344.8)	PSI (kPa)	5.0 (34.5)	
Oil Press Verify Time	15 to 300	SEC	45	
Liquid Flow Verify Time	0.5 to 5	MIN	5	
Recycle Control				
Restart Delta T	2.0 to 10.0 (1.1 to 5.6)	° F (° C)	5 (2.8)	
Shutdown Delta Speed (Q, R Compressors)	0.0 to 20.0	%	2.0	
Shutdown Delta Speed (P Compressor)	-10.0 to 20.0	%	0.5	
Shutdown Delta T	2.0 to 10.0 (1.1 to 5.6)	° F (° C)	5 (2.8)	
SPARE ALERT/ALARM ENABLE Disable=0, Lo=1/3, Hi=2/4				
Spare Temp #1 Enable	0 to 4		0	
Spare Temp #1 Limit	-40 to 245 (-40 to 118)	° F (° C)	245 (118)	
Spare Temp #2 Enable	0 to 4		0	
Spare Temp #2 Limit	-40 to 245 (-40 to 118)	° F (° C)	245 (118)	

23XRV PIC III SETUP2 TABLE CONFIGURATION SHEET

DESCRIPTION	STATUS	UNITS	DEFAULT	VALUE
Capacity Control				
Proportional Inc Band Q,R Compressors	2 to 10		6.5	
Proportional Inc Band P Compressor	2 to 15		12	
Proportional Dec Band	2 to 10		6.0	
Proportional ECL Gain	1 to 3		2.0	
VFD Control				
VFD Gain	0.1 to 1.5		0.75	
VFD Minimum Speed	15 to 50	%	20	
VFD Maximum Speed	50 to 100	%	100	
Vaporizer Heater Mode	0 to 1		0	
0 = Normal, 1 = Service				
Oil Reclaim Min Output	0 to 25	%	25	

23XRV PIC III SETUP3 TABLE CONFIGURATION SHEET

DESCRIPTION	STATUS	UNITS	DEFAULT	VALUE
Oil Sump and Vap. Heater Control				
Vap. Heater Turn On Speed	550 to 950	RPM	595	
Vap. Heater Turn Off Speed	600 to 2500	RPM	625	
Vap. Heater Turn On Lift	18 to 30 (10 to 17)	^F (^C)	22.5 (12.5)	
Vap. heater Turn Off Lift	25 to 30 (14 to 19)	^F (^C)	26 (14.4)	
Cond. Refrig Temp Low Limit	55 to 80 (33 to 27)	°F (°C)	70 (21)	
Sump Heater Turn On Speed	550 to 850	RPM	700	
Sump Heater Turn Off Speed	600 to 2500	RPM	750	
Sump Heater Turn On Lift	18 to 30 (10 to 17)	^F (^C)	22.0 (12)	
Sump Heater Turn Off Lift	20 to 60 (11 to 33)	^F (^C)	40 (22)	

23XRV PIC III SETUP4 DISPLAY SCREEN (P COMPRESSOR ONLY)

DESCRIPTION	STATUS	UNITS	DEFAULT	VALUE
Economizer Control				
Economizer Option	0/1	DS/ENABLE	DSABLE	
Econ Activate Speed	20 to 100	%	50	
Econ Activate Deadband	0 to 20	%	10	
Econ EXV Max Movement	0.5 to 5.0	%	3.0	
Superheat Setpoint	0.0 to 20.0 (0.0 to 11.1)	^F (^C)	6.0 (3.3)	
Econ Proportional Gain	0.1 to 2.0		0.1	
Econ PID Calc Time	10 to 120	SEC	25	

CUT ALONG DOTTED LINE

CUT ALONG DOTTED LINE

23XRV PIC III SETUP5 DISPLAY SCREEN (P COMPRESSOR ONLY)

DESCRIPTION	STATUS	UNITS	DEFAULT	VALUE
Condenser Level Control				
Cond EXV Max Movement	0.5 to 10.0	%	10	
Cond EXV Min Position	15 to 60	%	30	
Cond EXV Start Position	70 to 100	%	100	
Disch Superheat Limit	2 to 10 (1.1 to 5.6)	^F (^C)	6 (3.3)	
Cooler Approach Limit	1.5 to 20 (0.8 to 11.1)	^F (^C)	2.5 (1.4)	
Start Delay	0 to 255	SEC	120	
Freeze Margin at Start	0 to 10	^F	3	
Cond Loop Timer	5 to 10	SEC	5	
Cond Level Setpoint	0.5 to 4.8	V	3.0	
Disch Sup Ht Corr Factor	0 to 1	%	.01	
Evap App Corr Factor	0 to 2	%	0.5	
Fine Tune Enabled?	Y/N		Y	
Fine Tune Threshold	0.1 to 1	%	0.2	
Cond Level Deadband	0.0 to 1	V	0.4	
Anti Winding Min	15 to 60		30	
Cond Level Prop Gain	0.2 to 5		3.0	
Cond Level Int Gain	0.0 to 5.0		0.04	
Cond Level Clamp	0.5 to 3	%	1.5	
Cond Level Low Limit	0.5 to 4.8	V	1.6	
Cond Level High Limit	0.5 to 4.8	V	3.2	
Feed Forward Threshold	0.0 to 5.0		1.0	
Feed Forward Gain	0 to 30.0		0	
Evap Approach Reset Gain	0 to 15		10	

23XRV PIC III LEADLAG TABLE CONFIGURATION SHEET

DESDRIPTION	RANGE	UNITS	DEFAULT	VALUE
Lead Lag Control				
LEAD/LAG Configuration DSABLE=0, LEAD=1, LAG=2, STANDBY=3	0 to 3		0	
Load Balance Option	0/1	DSABLE/ENABLE	DSABLE	
Common Sensor Option	0/1	DSABLE/ENABLE	DSABLE	
LAG % Capacity	25 to 75	%	50	
LAG Address	1 to 236		92	
LAG START Timer	2 to 60	MIN	10	
LAG STOP Timer	2 to 60	MIN	10	
PRESTART FAULT Timer	2 to 30	MIN	5	
PULLDOWN Timer	1 to 30	MIN	2	
STANDBY Chiller Option	0/1	DSABLE/ENABLE	DSABLE	
STANDBY % Capacity	25 to 75	%	50	
STANDBY Address	1 to 236		93	

23XRV PIC III RAMP_DEM TABLE CONFIGURATION SHEET

DESCRIPTION	RANGE	UNITS	DEFAULT	VALUE
Pulldown Ramp Type: Select: Temp=0, kW=1	0/1		1	
Demand Limit and kW Ramp				
Demand Limit Source Select: Amps=0, kW=1	0/1		0	
Amps or kW Ramp % Min	5 to 20		10	
Demand Limit Prop Band	3 to 15	%	10	
Demand Limit At 20 mA	40 to 100	%	40	
20 mA Demand Limit Opt	0/1	DSABLE/ENABLE	DSABLE	
VFD Overload Decrease	25 to 50	%	30	
VFD Overload Delta	3 to 15	%	5	
Demand Watts Interval	5 to 60	MIN	15	

23XRV PIC III TEMP_CTL TABLE CONFIGURATION SHEET

DESCRIPTION	RANGE	UNITS	DEFAULT	VALUE
Control Point Source				
ECL Control Option	0/1	DSABLE/ENABLE	DSABLE	
Temp Pulldown Ramp/Min	2 to 10 (1.1 to 5.6)	^F (^C)	3 (1.7)	
Temperature Reset				
RESET TYPE 1				
Degrees Reset At 20 mA	-30 to 30 (-17 to 17)	^F (^C)	10 (6)	
RESET TYPE 2				
Remote Temp (- > No Reset)	-40 to 245 (-40 to 118)	^F (^C)	85 (29)	
Remote Temp (- > Full Reset)	-40 to 245 (-40 to 118)	^F (^C)	65 (18)	
Degrees Reset	-30 to 30 (-17 to 17)	^F (^C)	10 (6)	
RESET TYPE 3				
CHL Delta T (- > No Reset)	0 to 15 (0 to 8)	^F (^C)	10 (6)	
CHL Delta T (- > Full Reset)	0 to 15 (0 to 8)	^F (^C)	0 (0)	
Degrees Reset	-30 to 30 (-17 to 17)	^F (^C)	5 (3)	
Enable Reset Type	0 to 3		0	

23XRV BROADCAST (BRODEF) CONFIGURATION SHEET

DESCRIPTION	RANGE	UNITS	DEFAULT	VALUE
Time Broadcast Enable	0/1	DSABLE/ENABLE	DSABLE	
Daylight Savings				
Start Month	1 to 12		4	
Start Day of Week	1 to 7		7	
Start Week	1 to 5		1	
Start Time	00:00 to 24:00	HH:MM	02:00	
Start Advance	0 to 360	MIN	0	
Stop Month	1 to 12		10	
Stop Day of Week	1 to 7		7	
Stop Week	1 to 5		5	
Stop Time	00:00 to 24:00		02:00	
Stop Back	0 to 360	MIN	0	

CUT ALONG DOTTED LINE