

40VM Series Indoor Fan Coils VRF (Variable Refrigerant Flow) System 24V Interface Accessory

Installation and Operating Instructions

Part Number 40VM900008

SAFETY CONSIDERATIONS

Read and follow manufacturer instructions carefully. Follow all local electrical codes during installation. All wiring must conform to local and national electrical codes. Improper wiring or installation may damage thermostat.

Understand the signal words — DANGER, WARNING, and CAUTION. DANGER identifies the most serious hazards, which will result in severe personal injury or death. WARNING signifies hazards that could result in personal injury or death. CAUTION is used to identify unsafe practices, which would result in minor personal injury or product and property damage.

Recognize safety information. This is the safety-alert symbol (⚠). When this symbol is displayed on the unit and in instructions or manuals, be alert to the potential for personal injury. Installing, starting up, and servicing equipment can be hazardous due to system pressure, electrical components, and equipment location.

GENERAL

The 24V Interface for the VRF (Variable Refrigerant Flow) system is a device that enables the use of a conventional 24VAC thermostat with indoor units. The Interface receives 24VAC signals for Cool, Heat, and Fan; translates these commands to the system's communication protocol; and sends the commands to indoor unit over the HA/ HB communication bus.

The 24V Interface accessory is available for use with the VRF (variable refrigerant flow) system indoor units listed in Table 1.

Table 1 — 24V Interface Accessory Usage

UNIT	SIZES
40VMC Compact Cassette	007,009,012,015
40VMF 4-Way Cassette	009,012,015,018,024,030,036,048
40VMH High Static Ducted	024,030,036,048, 054, 072, 096
40VML Low Static Ducted	007, 009, 012, 015, 018, 024
40VMM Medium Static Ducted	007,009,012,015,018,024, 030,036, 048
40VMR Floor Console - Recessed	007, 009, 012, 015, 018, 024
40VMU Under Ceiling/Floor	012,018,024,030,036,048
40VMV Vertical AHU	018,024,030,036,048, 054
40VMW High Wall	007,009,012,015,018, 024, 030

WIRING REQUIREMENTS

24V Interface shall be configured for use with a conventional 24VAC thermostat with outputs for Fan, Heat, and Cool.

1. Wiring for Fan, Heat, and Cool signals from Thermostat to interface should be performed with 18 AWG thermostat wire.
2. Terminals on 24V interface support 24VAC ($\pm 10\%$) signal only.
3. Communication wiring from 24V Interface to Indoor Unit (HA/HB) should be 20-16 AWG, stranded, shielded control wire.

INSTALLATION

To install the 24V Interface:

1. Turn off all power to the indoor unit; turn off all power to field-supplied 24VAC transformer serving the thermostat.

⚠ WARNING

Electrical shock can cause personal injury and death. Before installing thermostat, shut off all power to this equipment during installation. There may be more than one power disconnect. Tag all disconnect locations to alert others not to restore power until work is completed.

2. If an existing thermostat is being replaced:
 - a. Remove existing thermostat from wall or unit.
 - b. Disconnect wires from existing thermostat. Do not allow wires to fall back into the wall or unit.
 - c. Discard or recycle old thermostat.

⚠ CAUTION





Failure to follow this caution may result in equipment damage or improper operation. Improper wiring or installation may damage the thermostat. Check to make sure wiring sequence is correct at both ends before proceeding with installation or turning on unit.

3. Select an appropriate location to install the 24V Interface—for example, inside a 4"x4" junction box. Coordinate with local electrical codes.
4. Connect HA HB terminals of 24V Interface to the HA HB terminal of the indoor unit control board using stranded, shielded control wiring.

NOTE: The thermostat and 24VAC power are field provided.

- Connect COOL, HEAT, FAN, and COMMON terminals of 24V Interface to Cool, Heat, Fan, and Common of the thermostat using 18 AWG thermostat wire.
- Using SW1 dip switches on 24V Interface, select IDU fan speed operation when thermostat calls for fan:

Table 2 — SW1 Fan Speed Selection

 ON SW1	00 selects low fan speed
 ON SW1	01 selects medium fan speed
 ON SW1	10 selects high fan speed
 ON SW1	11 selects auto fan speed

- Configure the third-party thermostat per manufacturer's instructions. If third-party thermostat has adjustable time delays among Fan, Heat, or Cool; disable them (i.e.

fan delays for gas furnace warm-up). Fan signal shall start/stop simultaneously with any call for Heat or Cool.

NOTES:

- The 24V Interface can only connect one thermostat and an indoor unit.
- COOL/HEAT/FAN inputs can only receive 24VAC signal with common ("C"/"COM") wire.
- The 24V Interface relies upon both the thermostat and the indoor unit's thermistors in order to monitor room temperature. The thermostat's sensor is used to set the room temperature. The indoor unit thermistor is used when calculating cooling and heating rate of change.
- When cooling signal is enabled, the IDU operates in cooling mode. When heating signal is enabled, the IDU operates in heating mode.
- The Fan signal is used only for the operation of IDU in Fan mode when there is no call for heating or cooling.
- While using 24V Interface, fan speed can only be set by the 24V Interface dip switches.
- 24V Interface is not recommended for systems using a Central Controller.
- The indoor unit will limit the temperature range set point based on the indoor unit's specifications.
- The 24V Interface does not support Carrier VRF ERV Interface.
- The 24V Interface is for indoor use only.

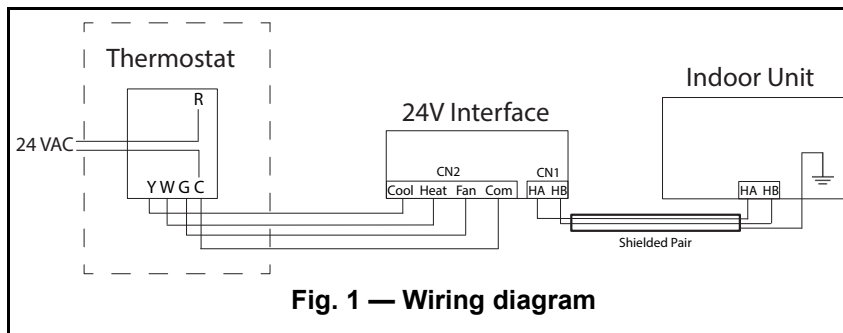

Fig. 1 — Wiring diagram

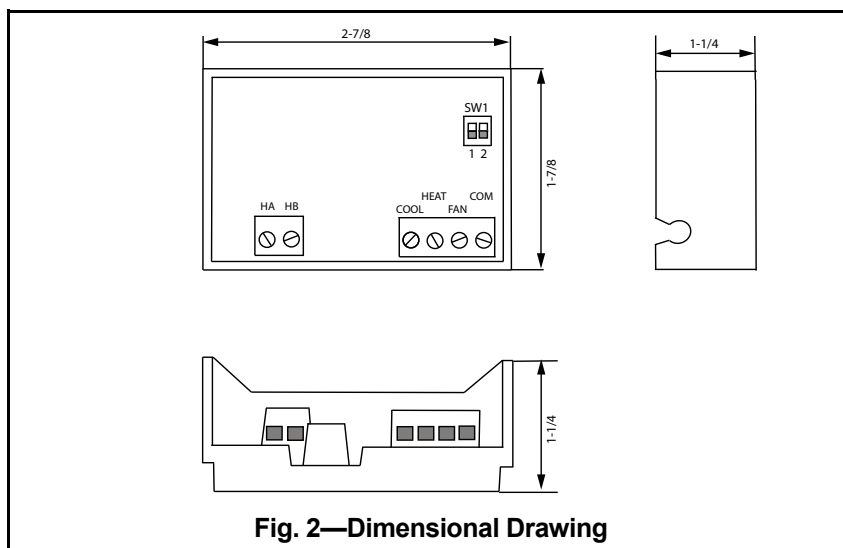

Fig. 2—Dimensional Drawing