

# Medium Static Ducted type

MMD-AP0074BH2UL-1 / MMD-AP0094BH2UL-1  
MMD-AP0124BH2UL-1 / MMD-AP0154BH2UL-1  
MMD-AP0184BH2UL-1 / MMD-AP0214BH2UL-1  
MMD-AP0244BH2UL-1 / MMD-AP0304BH2UL-1  
MMD-AP0364BH2UL-1 / MMD-AP0424BH2UL-1  
MMD-AP0484BH2UL-1



## Contents

1. Specifications
2. Dimensions
3. Center of gravity
4. Piping diagram
5. Wiring diagram
6. Electrical current characteristics
7. Sensible capacity table
8. Fan characteristics
9. Sound data
10. Accessories
11. Reference

## 1. Specifications



### Medium Static Ducted type

Model name		MMD-	AP0074 BH2UL-1	AP0094 BH2UL-1	AP0124 BH2UL-1	AP0154 BH2UL-1	AP0184 BH2UL-1	AP0214 BH2UL-1	AP0244 BH2UL-1	AP0304 BH2UL-1	AP0364 BH2UL-1	AP0424 BH2UL-1	AP0484 BH2UL-1		
Cooling Capacity		kBtu/h	7.5	9.5	12	15.4	18	21	24	30	36	42	48		
Heating Capacity		kBtu/h	8.5	10.5	13.5	17	20	24	27	34	40	47.5	54		
Electrical characteristics	Power supply		230 V (208/230 V) 1phase 60 Hz												
	Power consumption		kW	0.044	0.044	0.044	0.091	0.091	0.091	0.091	0.091	0.106	0.142	0.142	
Appearance		Zinc hot dipping steel plate													
Dimension	Unit	Height	In	12.6											
		Width	In	27.6			39.4			53.2					
		Depth	In	31.5											
	Packing	Height	In	14.6											
		Width	In	36.1			47.9			61.7					
		Depth	In	38.4											
Total weight	Unit		lbs	70			93			119					
	Packed unit		lbs	80			104			135					
Heat exchanger		Finned tube													
Fan unit	Fan		Centrifugal fan												
	Standard air flow (High/Mid/Low)		cfm	304 / 258 / 220			556 / 465 / 394			694 / 555 / 475			1000 / 890 / 765	1180 / 1050 / 925	
	Motor		W	150	150	150	150	150	150	150	150	150	150	150	
	External static pressure (*1)		In.WG	0.15-0.25(Factory default)-0.35-0.46											
Air filter		Field supply													
Connecting pipe	Gas side		In	3/8"	3/8"	3/8"	1/2"	1/2"	5/8"	5/8"	5/8"	5/8"	5/8"	5/8"	
	Liquid side		In	1/4"	1/4"	1/4"	1/4"	1/4"	3/8"	3/8"	3/8"	3/8"	3/8"	3/8"	
	Drain port (Nominal dia.)		In	VP25(Polyvinyl chloride tube: External Dia.1-1/4 Internal Dia.1)											
Sound pressure level (*2) (High/Mid/Low)		dB(A)	33/30/27			37/35/31			37/35/34			41/39/37	42/40/38		
Option parts	Fan guard		TCB-IG071BUL-1			TCB-IG151BUL			TCB-IG211BUL						
	Auxiliary fresh air flange		TCB-FF151US-UL												

#### Note

(\*1) Non attached filter.

(\*2) The actual values in an external operating environment are generally higher than the indicated values due to the contribution from ambient noise.

2. Dimensions

MMD-AP0074BH2UL-1, AP0094BH2UL-1, AP0124BH2UL-1, AP0154BH2UL-1, AP0184BH2UL-1, AP0214BH2UL-1, AP0244BH2UL-1, AP0304BH2UL-1, AP0364BH2UL-1, AP0424BH2UL-1, AP0484BH2UL-1

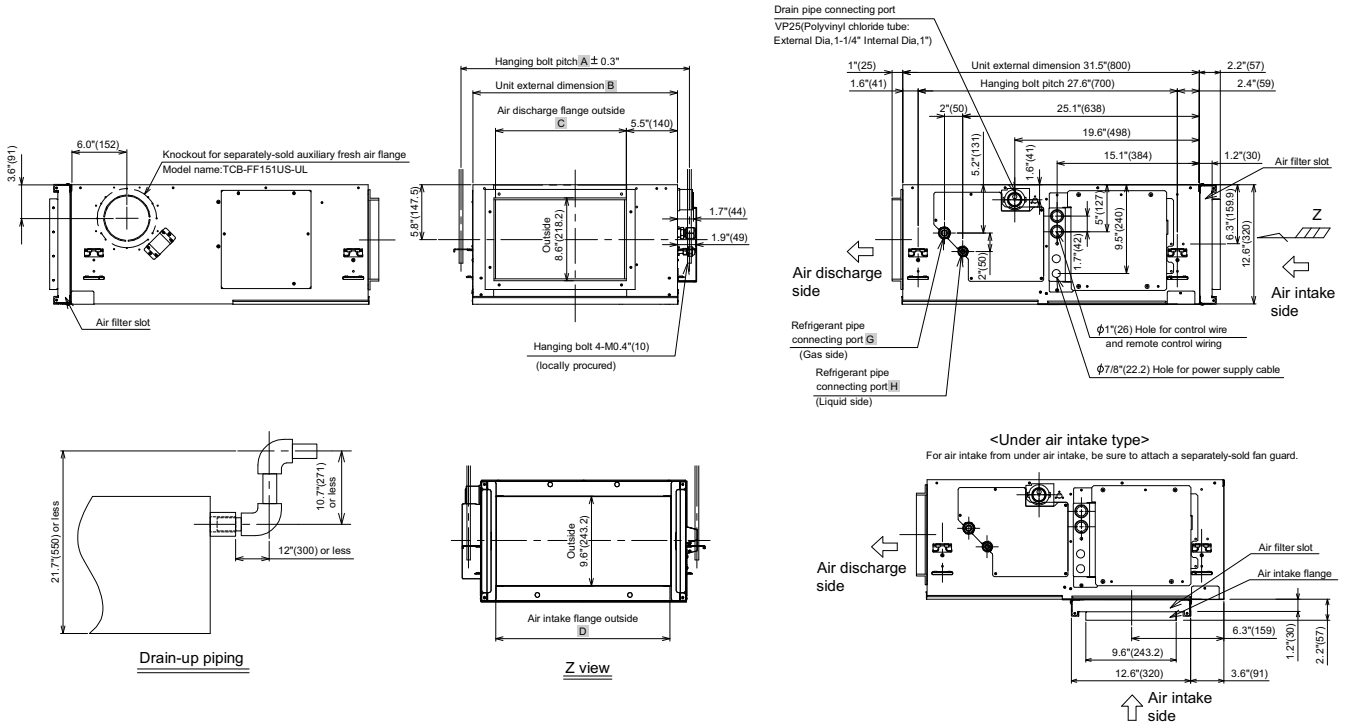

Space required for installation and servicing

Reserve space required for maintenance the indoor unit and service work.

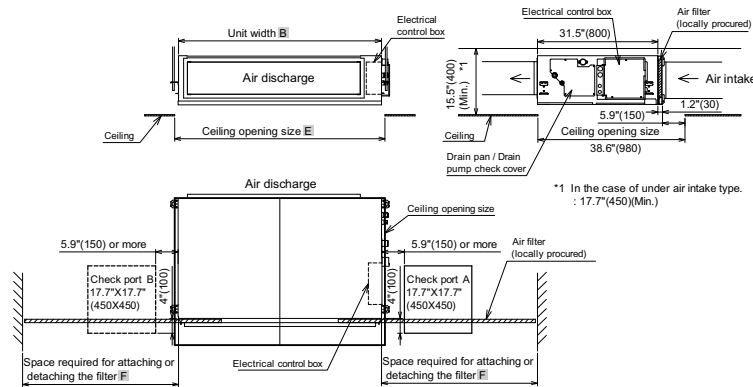

Notes

- \* Set check port A for maintaining the electrical control box, filter, drain pump, drain pipe, and refrigerant pipe.
- \* Replace the filter through check port A or B.  
(If you pull out the filter in the opposite direction of the electrical control box, check port B is required.)
- Reserve space F required for attaching or detaching the filter.  
Otherwise, the filter cannot be replaced.
- \* When pulling the refrigerant pipe, drain pipe, etc, avoid the filter port. Otherwise, the filter cannot be replaced.
- \* The indoor unit is not equipped with an air filter. Procure and install with locally.
- \* Set a ceiling opening port for maintaining the fan, fan motor, etc. Otherwise, they cannot be maintained.

Unit: in (mm)

Model	MMD-	A	B	C	D	E	F	G	H	Air filter wide
AP0074BH2UL-1, AP0094BH2UL-1, AP0124BH2UL-1		30.2" (766)	27.6" (700)	19.7" (501.6)	24.5" (621.6)	29.5" (750)	28.7" (730)	Ø3/8" (9.5)	Ø1/4" (6.4)	25" (635)
AP0154BH2UL-1, AP0184BH2UL-1		42" (1066)	39.4" (1000)	31.6" (801.6)	36.3" (921.6)	41.3" (1050)	23.6" (600)	Ø1/2" (12.7)	Ø1/4" (6.4)	38"(18"+20") (965(457+508))
AP0214BH2UL-1, AP0244BH2UL-1, AP0304BH2UL-1, AP0364BH2UL-1, AP0424BH2UL-1, AP0484BH2UL-1		55.7" (1416)	53.2" (1350)	45.4" (1151.6)	50.1" (1271.6)	55.1" (1400)	40.5" (1030)	Ø5/8" (15.9)	Ø3/8" (9.5)	52"(20"+20"+12") (1321(508+508+305))

3. Center of gravity

Model name	X (In)	Y (In)	Z (In)	Total weight (lbs)
MMD-AP0074BH2UL-1 MMD-AP0094BH2UL-1 MMD-AP0124BH2UL-1	17.7	14.4	5.91	70
MMD-AP0154BH2UL-1 MMD-AP0184BH2UL-1	17.5	18.1	5.91	93
MMD-AP0214BH2UL-1 MMD-AP0244BH2UL-1 MMD-AP0304BH2UL-1 MMD-AP0364BH2UL-1 MMD-AP0424BH2UL-1 MMD-AP0484BH2UL-1	17.7	24.8	5.91	119

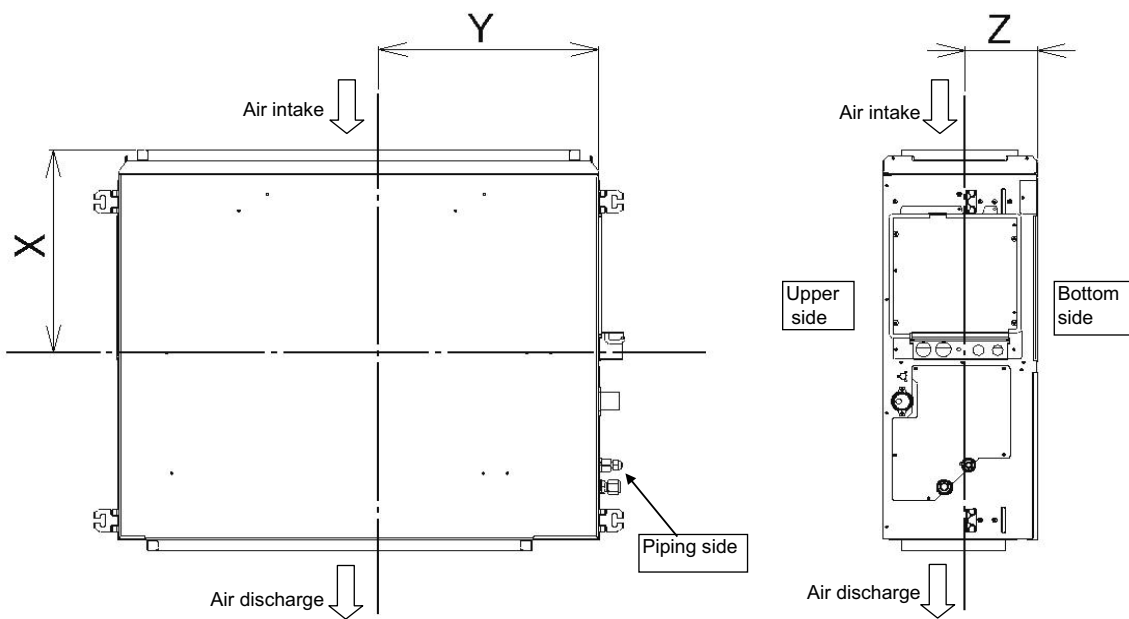

4. Piping diagram

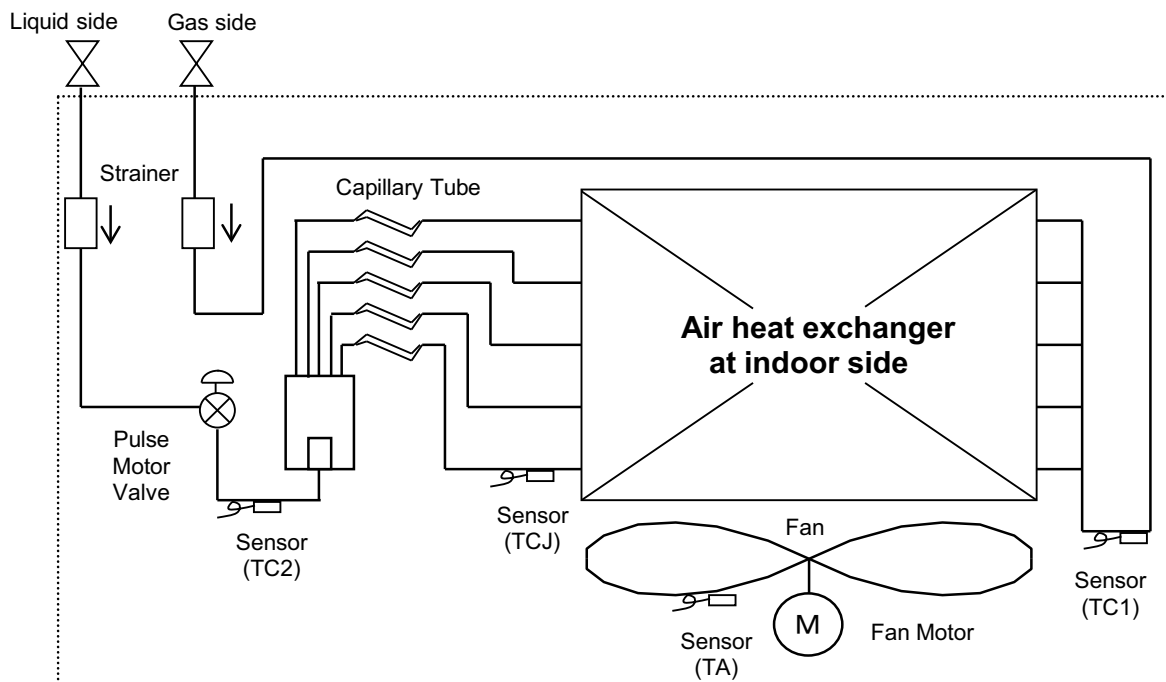

5. Wiring diagram

MMD-AP0074BH2UL-1, AP0094BH2UL-1, AP0124BH2UL-1, AP0154BH2UL-1, AP0184BH2UL-1, AP0214BH2UL-1, AP0244BH2UL-1, AP0304BH2UL-1, AP0364BH2UL-1, AP0424BH2UL-1, AP0484BH2UL-1

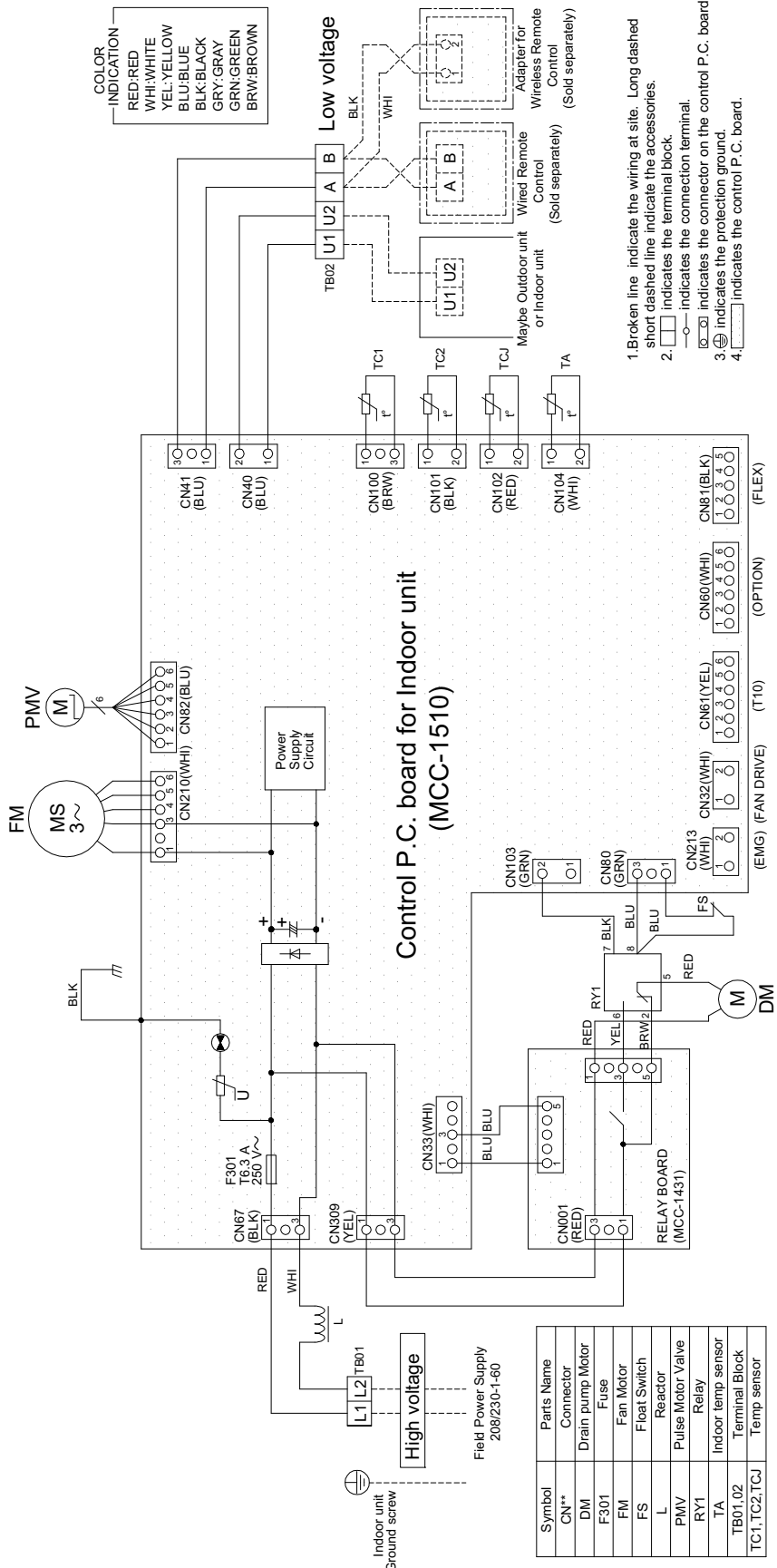

Symbol	Parts Name
CN**	Connector
DM	Drain pump Motor
F301	Fuse
FM	Fan Motor
FS	Float Switch
L	Reactor
PMV	Pulse Motor Valve
RY1	Relay
TA	Indoor temp sensor
TB01,02	Terminal Block
TC1,TC2,TCJ	Temp sensor

## 6. Electrical current characteristics

Type	Model	Nominal Voltage (V-Ph-Hz)	Voltage Range (V)		Power consumption kW	FLA A	MCA A	MOCP A
			Min	Max				
Medium Static Ducted type	MMD-AP0074BH2UL-1	208/230-1-60	187	253	0.038	0.7	0.9	15
	MMD-AP0094BH2UL-1	208/230-1-60	187	253	0.038	0.7	0.9	15
	MMD-AP0124BH2UL-1	208/230-1-60	187	253	0.042	0.7	0.9	15
	MMD-AP0154BH2UL-1	208/230-1-60	187	253	0.091	0.9	1.2	15
	MMD-AP0184BH2UL-1	208/230-1-60	187	253	0.091	0.9	1.2	15
	MMD-AP0214BH2UL-1	208/230-1-60	187	253	0.091	1.4	1.8	15
	MMD-AP0244BH2UL-1	208/230-1-60	187	253	0.091	1.4	1.8	15
	MMD-AP0304BH2UL-1	208/230-1-60	187	253	0.106	1.4	1.8	15
	MMD-AP0364BH2UL-1	208/230-1-60	187	253	0.106	1.8	2.3	15
	MMD-AP0424BH2UL-1	208/230-1-60	187	253	0.142	2.2	2.8	15
MMD-AP0484BH2UL-1	208/230-1-60	187	253	0.142	2.2	2.8	15	

MCA: Minimum Circuit Amps

FLA: Full Load Amps

MOCP: Maximum Overcurrent Protection (Amps)

7. Sensible capacity table

Medium Static Ducted type (MMD-AP\_\_4BH2UL-1)

TC: Total capacity [Btu/h] SHC: Sensible capacity [Btu/h]

unit size	outdoor air temp. °FDB	indoor air temp.													
		59 °FWB		61 °FWB		64 °FWB		67 °FWB		68 °FWB		72 °FWB		75 °FWB	
		71 °FDB		73 °FDB		77 °FDB		80 °FDB		82 °FDB		86 °FDB		90 °FDB	
		TC	SHC	TC	SHC	TC	SHC	TC	SHC	TC	SHC	TC	SHC	TC	SHC
007	50	6380	5920	6680	6080	7100	6330	7500	6530	7630	6550	8110	6460	8450	6230
	54	6380	5920	6680	6080	7100	6330	7500	6530	7630	6550	8110	6460	8450	6230
	57	6380	5920	6680	6080	7100	6330	7500	6530	7630	6550	8110	6460	8450	6230
	61	6380	5920	6680	6080	7100	6330	7500	6530	7630	6550	8110	6460	8450	6230
	64	6380	5920	6680	6080	7100	6330	7500	6530	7630	6550	8110	6460	8450	6230
	68	6380	5920	6680	6080	7100	6330	7500	6530	7630	6550	8110	6460	8450	6230
	70	6380	5920	6680	6080	7100	6330	7500	6530	7630	6550	8110	6460	8450	6230
	73	6380	5920	6680	6080	7100	6330	7500	6530	7630	6550	8110	6460	8450	6230
	77	6380	5920	6680	6080	7100	6330	7500	6530	7630	6550	8110	6460	8450	6230
	81	6380	5920	6680	6080	7100	6330	7500	6530	7630	6550	8110	6460	8450	6230
	84	6380	5920	6680	6080	7100	6330	7500	6530	7630	6550	8110	6460	8450	6230
	88	6380	5920	6680	6080	7100	6330	7500	6530	7630	6550	8110	6460	8450	6230
	91	6380	5920	6680	6080	7100	6330	7500	6530	7630	6550	8110	6460	8450	6230
	95	6380	5920	6680	6080	7100	6330	7500	6530	7630	6550	8110	6460	8450	6230
99	6190	5750	6490	5900	6890	6150	7280	6340	7410	6360	7870	6270	8200	6050	
102	6050	5610	6330	5760	6730	6000	7110	6190	7230	6210	7690	6120	8010	5910	
009	50	8090	6810	8460	7000	9000	7280	9500	7510	9660	7530	10270	7430	10700	7160
	54	8090	6810	8460	7000	9000	7280	9500	7510	9660	7530	10270	7430	10700	7160
	57	8090	6810	8460	7000	9000	7280	9500	7510	9660	7530	10270	7430	10700	7160
	61	8090	6810	8460	7000	9000	7280	9500	7510	9660	7530	10270	7430	10700	7160
	64	8090	6810	8460	7000	9000	7280	9500	7510	9660	7530	10270	7430	10700	7160
	68	8090	6810	8460	7000	9000	7280	9500	7510	9660	7530	10270	7430	10700	7160
	70	8090	6810	8460	7000	9000	7280	9500	7510	9660	7530	10270	7430	10700	7160
	73	8090	6810	8460	7000	9000	7280	9500	7510	9660	7530	10270	7430	10700	7160
	77	8090	6810	8460	7000	9000	7280	9500	7510	9660	7530	10270	7430	10700	7160
	81	8090	6810	8460	7000	9000	7280	9500	7510	9660	7530	10270	7430	10700	7160
	84	8090	6810	8460	7000	9000	7280	9500	7510	9660	7530	10270	7430	10700	7160
	88	8090	6810	8460	7000	9000	7280	9500	7510	9660	7530	10270	7430	10700	7160
	91	8090	6810	8460	7000	9000	7280	9500	7510	9660	7530	10270	7430	10700	7160
	95	8090	6810	8460	7000	9000	7280	9500	7510	9660	7530	10270	7430	10700	7160
99	7860	6610	8210	6800	8740	7070	9220	7290	9380	7310	9970	7210	10390	6950	
102	7670	6460	8020	6640	8530	6900	9010	7120	9160	7140	9740	7040	10140	6790	
012	50	10210	7400	10690	7600	11360	7910	12000	8160	12210	8190	12980	8080	13510	7770
	54	10210	7400	10690	7600	11360	7910	12000	8160	12210	8190	12980	8080	13510	7770
	57	10210	7400	10690	7600	11360	7910	12000	8160	12210	8190	12980	8080	13510	7770
	61	10210	7400	10690	7600	11360	7910	12000	8160	12210	8190	12980	8080	13510	7770
	64	10210	7400	10690	7600	11360	7910	12000	8160	12210	8190	12980	8080	13510	7770
	68	10210	7400	10690	7600	11360	7910	12000	8160	12210	8190	12980	8080	13510	7770
	70	10210	7400	10690	7600	11360	7910	12000	8160	12210	8190	12980	8080	13510	7770
	73	10210	7400	10690	7600	11360	7910	12000	8160	12210	8190	12980	8080	13510	7770
	77	10210	7400	10690	7600	11360	7910	12000	8160	12210	8190	12980	8080	13510	7770
	81	10210	7400	10690	7600	11360	7910	12000	8160	12210	8190	12980	8080	13510	7770
	84	10210	7400	10690	7600	11360	7910	12000	8160	12210	8190	12980	8080	13510	7770
	88	10210	7400	10690	7600	11360	7910	12000	8160	12210	8190	12980	8080	13510	7770
	91	10210	7400	10690	7600	11360	7910	12000	8160	12210	8190	12980	8080	13510	7770
	95	10210	7400	10690	7600	11360	7910	12000	8160	12210	8190	12980	8080	13510	7770
99	9910	7190	10380	7380	11030	7680	11650	7920	11860	7950	12600	7850	13120	7540	
102	9680	7020	10130	7200	10770	7500	11380	7740	11580	7760	12310	7660	12810	7370	
015	50	13110	11450	13710	11760	14580	12240	15400	12630	15660	12660	16660	12510	17340	12040
	54	13110	11450	13710	11760	14580	12240	15400	12630	15660	12660	16660	12510	17340	12040
	57	13110	11450	13710	11760	14580	12240	15400	12630	15660	12660	16660	12510	17340	12040
	61	13110	11450	13710	11760	14580	12240	15400	12630	15660	12660	16660	12510	17340	12040
	64	13110	11450	13710	11760	14580	12240	15400	12630	15660	12660	16660	12510	17340	12040
	68	13110	11450	13710	11760	14580	12240	15400	12630	15660	12660	16660	12510	17340	12040
	70	13110	11450	13710	11760	14580	12240	15400	12630	15660	12660	16660	12510	17340	12040
	73	13110	11450	13710	11760	14580	12240	15400	12630	15660	12660	16660	12510	17340	12040
	77	13110	11450	13710	11760	14580	12240	15400	12630	15660	12660	16660	12510	17340	12040
	81	13110	11450	13710	11760	14580	12240	15400	12630	15660	12660	16660	12510	17340	12040
	84	13110	11450	13710	11760	14580	12240	15400	12630	15660	12660	16660	12510	17340	12040
	88	13110	11450	13710	11760	14580	12240	15400	12630	15660	12660	16660	12510	17340	12040
	91	13110	11450	13710	11760	14580	12240	15400	12630	15660	12660	16660	12510	17340	12040
	95	13110	11450	13710	11760	14580	12240	15400	12630	15660	12660	16660	12510	17340	12040
99	12730	11120	13310	11420	14160	11890	14950	12260	15210	12290	16180	12150	16840	11690	
102	12430	10850	13000	11150	13820	11600	14600	11970	14850	12000	15790	11860	16440	11410	

Medium Static Ducted type (MMD-AP\_\_4BH2UL-1)

TC: Total capacity [Btu/h] SHC: Sensible capacity [Btu/h]

unit size	outdoor air temp. °FDB	indoor air temp.													
		59 °FWB		61 °FWB		64 °FWB		67 °FWB		68 °FWB		72 °FWB		75 °FWB	
		71 °FDB		73 °FDB		77 °FDB		80 °FDB		82 °FDB		86 °FDB		90 °FDB	
		TC	SHC	TC	SHC	TC	SHC	TC	SHC	TC	SHC	TC	SHC	TC	SHC
018	50	15320	12400	16030	12740	17040	13260	18000	13680	18310	13720	19470	13550	20270	13040
	54	15320	12400	16030	12740	17040	13260	18000	13680	18310	13720	19470	13550	20270	13040
	57	15320	12400	16030	12740	17040	13260	18000	13680	18310	13720	19470	13550	20270	13040
	61	15320	12400	16030	12740	17040	13260	18000	13680	18310	13720	19470	13550	20270	13040
	64	15320	12400	16030	12740	17040	13260	18000	13680	18310	13720	19470	13550	20270	13040
	68	15320	12400	16030	12740	17040	13260	18000	13680	18310	13720	19470	13550	20270	13040
	70	15320	12400	16030	12740	17040	13260	18000	13680	18310	13720	19470	13550	20270	13040
	73	15320	12400	16030	12740	17040	13260	18000	13680	18310	13720	19470	13550	20270	13040
	77	15320	12400	16030	12740	17040	13260	18000	13680	18310	13720	19470	13550	20270	13040
	81	15320	12400	16030	12740	17040	13260	18000	13680	18310	13720	19470	13550	20270	13040
	84	15320	12400	16030	12740	17040	13260	18000	13680	18310	13720	19470	13550	20270	13040
	88	15320	12400	16030	12740	17040	13260	18000	13680	18310	13720	19470	13550	20270	13040
91	15320	12400	16030	12740	17040	13260	18000	13680	18310	13720	19470	13550	20270	13040	
95	15320	12400	16030	12740	17040	13260	18000	13680	18310	13720	19470	13550	20270	13040	
99	14880	12040	15570	12370	16550	12880	17480	13280	17780	13320	18910	13160	19680	12660	
102	14520	11760	15200	12080	16150	12570	17060	12970	17360	13010	18460	12850	19220	12360	
021	50	17240	14340	19070	15270	20370	16220	21000	16170	21630	16170	22890	16020	23940	15650
	54	17240	14340	19070	15270	20370	16220	21000	16170	21630	16170	22890	16020	23940	15650
	57	17240	14340	19070	15270	20370	16220	21000	16170	21630	16170	22890	16020	23940	15650
	61	17240	14340	19070	15270	20370	16220	21000	16170	21630	16170	22890	16020	23940	15650
	64	17240	14340	19070	15270	20370	16220	21000	16170	21630	16170	22890	16020	23940	15650
	68	17240	14340	19070	15270	20370	16220	21000	16170	21630	16170	22890	16020	23940	15650
	70	17240	14340	19070	15270	20370	16220	21000	16170	21630	16170	22890	16020	23940	15650
	73	17240	14340	19070	15270	20370	16220	21000	16170	21630	16170	22890	16020	23940	15650
	77	17240	14340	19070	15270	20370	16220	21000	16170	21630	16170	22890	16020	23940	15650
	81	17240	14340	19070	15270	20370	16220	21000	16170	21630	16170	22890	16020	23940	15650
	84	17240	14340	19070	15270	20370	16220	21000	16170	21630	16170	22890	16020	23940	15650
	88	17240	14340	19070	15270	20370	16220	21000	16170	21630	16170	22890	16020	23940	15650
91	17240	14340	19070	15270	20370	16220	21000	16170	21630	16170	22890	16020	23940	15650	
95	17240	14340	19070	15270	20370	16220	21000	16170	21630	16170	22890	16020	23940	15650	
99	16740	13920	18520	14830	19780	15750	20390	15700	21000	15700	22230	15560	23250	15200	
102	16340	13590	18080	14480	19310	15380	19910	15330	20510	15330	21700	15190	22700	14840	
024	50	19704	15322	21792	16318	23280	17331	24000	17280	24720	17279	26160	17120	27360	16724
	54	19704	15322	21792	16318	23280	17331	24000	17280	24720	17279	26160	17120	27360	16724
	57	19704	15322	21792	16318	23280	17331	24000	17280	24720	17279	26160	17120	27360	16724
	61	19704	15322	21792	16318	23280	17331	24000	17280	24720	17279	26160	17120	27360	16724
	64	19704	15322	21792	16318	23280	17331	24000	17280	24720	17279	26160	17120	27360	16724
	68	19704	15322	21792	16318	23280	17331	24000	17280	24720	17279	26160	17120	27360	16724
	70	19704	15322	21792	16318	23280	17331	24000	17280	24720	17279	26160	17120	27360	16724
	73	19704	15322	21792	16318	23280	17331	24000	17280	24720	17279	26160	17120	27360	16724
	77	19704	15322	21792	16318	23280	17331	24000	17280	24720	17279	26160	17120	27360	16724
	81	19704	15322	21792	16318	23280	17331	24000	17280	24720	17279	26160	17120	27360	16724
	84	19704	15322	21792	16318	23280	17331	24000	17280	24720	17279	26160	17120	27360	16724
	88	19704	15322	21792	16318	23280	17331	24000	17280	24720	17279	26160	17120	27360	16724
91	19704	15322	21792	16318	23280	17331	24000	17280	24720	17279	26160	17120	27360	16724	
95	19704	15322	21792	16318	23280	17331	24000	17280	24720	17279	26160	17120	27360	16724	
99	19133	14877	21160	15845	22605	16829	23304	16779	24003	16778	25401	16623	26567	16239	
102	18679	14525	20659	15469	22069	16430	22752	16381	23435	16380	24800	16229	25937	15854	
030	50	24630	17560	27240	18700	29100	19860	30000	19800	30900	19800	32700	19620	34200	19160
	54	24630	17560	27240	18700	29100	19860	30000	19800	30900	19800	32700	19620	34200	19160
	57	24630	17560	27240	18700	29100	19860	30000	19800	30900	19800	32700	19620	34200	19160
	61	24630	17560	27240	18700	29100	19860	30000	19800	30900	19800	32700	19620	34200	19160
	64	24630	17560	27240	18700	29100	19860	30000	19800	30900	19800	32700	19620	34200	19160
	68	24630	17560	27240	18700	29100	19860	30000	19800	30900	19800	32700	19620	34200	19160
	70	24630	17560	27240	18700	29100	19860	30000	19800	30900	19800	32700	19620	34200	19160
	73	24630	17560	27240	18700	29100	19860	30000	19800	30900	19800	32700	19620	34200	19160
	77	24630	17560	27240	18700	29100	19860	30000	19800	30900	19800	32700	19620	34200	19160
	81	24630	17560	27240	18700	29100	19860	30000	19800	30900	19800	32700	19620	34200	19160
	84	24630	17560	27240	18700	29100	19860	30000	19800	30900	19800	32700	19620	34200	19160
	88	24630	17560	27240	18700	29100	19860	30000	19800	30900	19800	32700	19620	34200	19160
91	24630	17560	27240	18700	29100	19860	30000	19800	30900	19800	32700	19620	34200	19160	
95	24630	17560	27240	18700	29100	19860	30000	19800	30900	19800	32700	19620	34200	19160	
99	23920	17050	26450	18160	28260	19280	29130	19230	30000	19230	31750	19050	33210	18600	
102	23350	16650	25820	17730	27590	18830	28440	18770	29290	18770	31000	18600	32420	18160	



Medium Static Ducted type (MMD-AP\_\_4BH2UL-1)

TC: Total capacity [Btu/h] SHC: Sensible capacity [Btu/h]

unit size	outdoor air temp. °FDB	indoor air temp.													
		59 °FWB		61 °FWB		64 °FWB		67 °FWB		68 °FWB		72 °FWB		75 °FWB	
		71 °FDB		73 °FDB		77 °FDB		80 °FDB		82 °FDB		86 °FDB		90 °FDB	
		TC	SHC	TC	SHC	TC	SHC	TC	SHC	TC	SHC	TC	SHC	TC	SHC
036	50	29560	24260	32690	25840	34920	27440	36000	27360	37080	27360	39240	27110	41040	26480
	54	29560	24260	32690	25840	34920	27440	36000	27360	37080	27360	39240	27110	41040	26480
	57	29560	24260	32690	25840	34920	27440	36000	27360	37080	27360	39240	27110	41040	26480
	61	29560	24260	32690	25840	34920	27440	36000	27360	37080	27360	39240	27110	41040	26480
	64	29560	24260	32690	25840	34920	27440	36000	27360	37080	27360	39240	27110	41040	26480
	68	29560	24260	32690	25840	34920	27440	36000	27360	37080	27360	39240	27110	41040	26480
	70	29560	24260	32690	25840	34920	27440	36000	27360	37080	27360	39240	27110	41040	26480
	73	29560	24260	32690	25840	34920	27440	36000	27360	37080	27360	39240	27110	41040	26480
	77	29560	24260	32690	25840	34920	27440	36000	27360	37080	27360	39240	27110	41040	26480
	81	29560	24260	32690	25840	34920	27440	36000	27360	37080	27360	39240	27110	41040	26480
	84	29560	24260	32690	25840	34920	27440	36000	27360	37080	27360	39240	27110	41040	26480
	88	29560	24260	32690	25840	34920	27440	36000	27360	37080	27360	39240	27110	41040	26480
	91	29560	24260	32690	25840	34920	27440	36000	27360	37080	27360	39240	27110	41040	26480
95	29560	24260	32690	25840	34920	27440	36000	27360	37080	27360	39240	27110	41040	26480	
99	28700	23560	31740	25090	33910	26640	34960	26570	36000	26570	38100	26320	39850	25710	
102	28020	23000	30990	24500	33100	26010	34130	25940	35150	25940	37200	25700	38910	25100	
042	50	34480	26810	38140	28560	40740	30330	42000	30240	43260	30240	45780	29960	47880	29270
	54	34480	26810	38140	28560	40740	30330	42000	30240	43260	30240	45780	29960	47880	29270
	57	34480	26810	38140	28560	40740	30330	42000	30240	43260	30240	45780	29960	47880	29270
	61	34480	26810	38140	28560	40740	30330	42000	30240	43260	30240	45780	29960	47880	29270
	64	34480	26810	38140	28560	40740	30330	42000	30240	43260	30240	45780	29960	47880	29270
	68	34480	26810	38140	28560	40740	30330	42000	30240	43260	30240	45780	29960	47880	29270
	70	34480	26810	38140	28560	40740	30330	42000	30240	43260	30240	45780	29960	47880	29270
	73	34480	26810	38140	28560	40740	30330	42000	30240	43260	30240	45780	29960	47880	29270
	77	34480	26810	38140	28560	40740	30330	42000	30240	43260	30240	45780	29960	47880	29270
	81	34480	26810	38140	28560	40740	30330	42000	30240	43260	30240	45780	29960	47880	29270
	84	34480	26810	38140	28560	40740	30330	42000	30240	43260	30240	45780	29960	47880	29270
	88	34480	26810	38140	28560	40740	30330	42000	30240	43260	30240	45780	29960	47880	29270
	91	34480	26810	38140	28560	40740	30330	42000	30240	43260	30240	45780	29960	47880	29270
95	34480	26810	38140	28560	40740	30330	42000	30240	43260	30240	45780	29960	47880	29270	
99	33480	26030	37030	27730	39560	29450	40780	29360	42010	29360	44450	29090	46490	28420	
102	32690	25420	36160	27070	38620	28750	39820	28670	41010	28670	43400	28400	45390	27750	
048	50	39410	29370	43580	31270	46560	33220	48000	33120	49440	33120	52320	32810	54720	32050
	54	39410	29370	43580	31270	46560	33220	48000	33120	49440	33120	52320	32810	54720	32050
	57	39410	29370	43580	31270	46560	33220	48000	33120	49440	33120	52320	32810	54720	32050
	61	39410	29370	43580	31270	46560	33220	48000	33120	49440	33120	52320	32810	54720	32050
	64	39410	29370	43580	31270	46560	33220	48000	33120	49440	33120	52320	32810	54720	32050
	68	39410	29370	43580	31270	46560	33220	48000	33120	49440	33120	52320	32810	54720	32050
	70	39410	29370	43580	31270	46560	33220	48000	33120	49440	33120	52320	32810	54720	32050
	73	39410	29370	43580	31270	46560	33220	48000	33120	49440	33120	52320	32810	54720	32050
	77	39410	29370	43580	31270	46560	33220	48000	33120	49440	33120	52320	32810	54720	32050
	81	39410	29370	43580	31270	46560	33220	48000	33120	49440	33120	52320	32810	54720	32050
	84	39410	29370	43580	31270	46560	33220	48000	33120	49440	33120	52320	32810	54720	32050
	88	39410	29370	43580	31270	46560	33220	48000	33120	49440	33120	52320	32810	54720	32050
	91	39410	29370	43580	31270	46560	33220	48000	33120	49440	33120	52320	32810	54720	32050
95	39410	29370	43580	31270	46560	33220	48000	33120	49440	33120	52320	32810	54720	32050	
99	38270	28520	42320	30360	45210	32260	46610	32160	48010	32160	50800	31860	53130	31120	
102	37360	27840	41310	29640	44140	31490	45500	31400	46870	31400	49600	31100	51870	30380	

8. Fan characteristics

Rear suction (No filter)

\* It is not possible to use the level of external static pressure that is lower than the resistance pressure of the filter (locally procured). Therefore be sure to check the pressure of installed filter, and to set correct pressure level that is higher than pressure of the filter.

MMD-AP0074BH2UL-1, MMD-AP0094BH2UL-1  
MMD-AP0124BH2UL-1

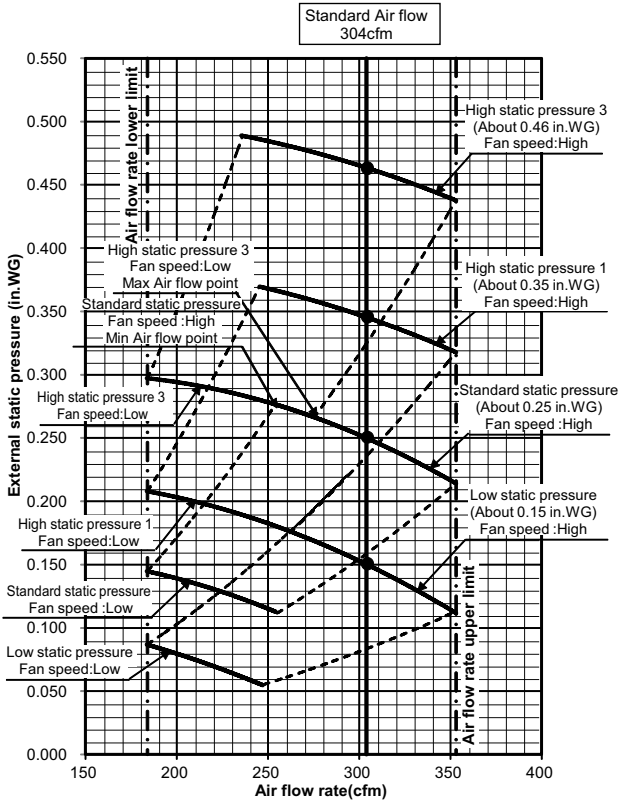

MMD-AP0154BH2UL-1, MMD-AP0184BH2UL-1

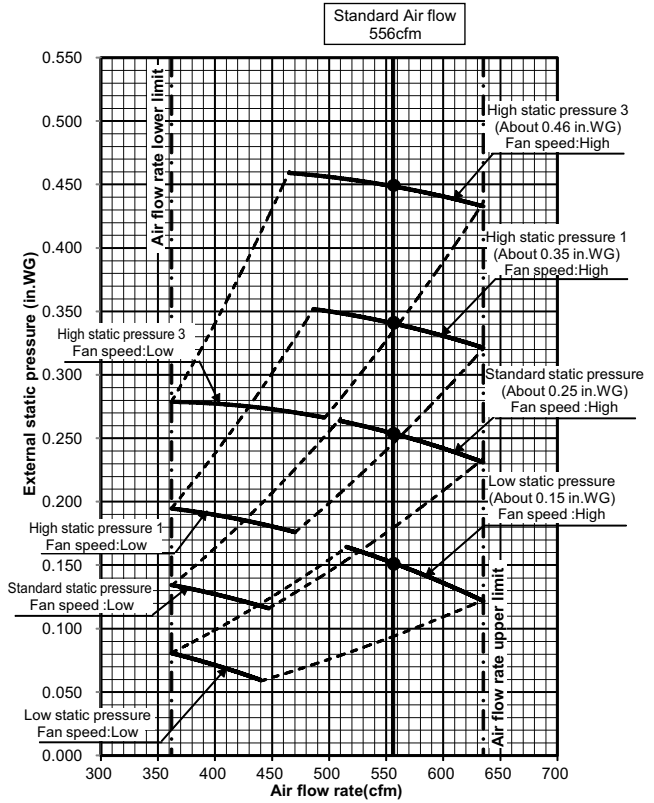

MMD-AP0214BH2UL-1, MMD-AP0244BH2UL-1  
MMD-AP0304BH2UL-1

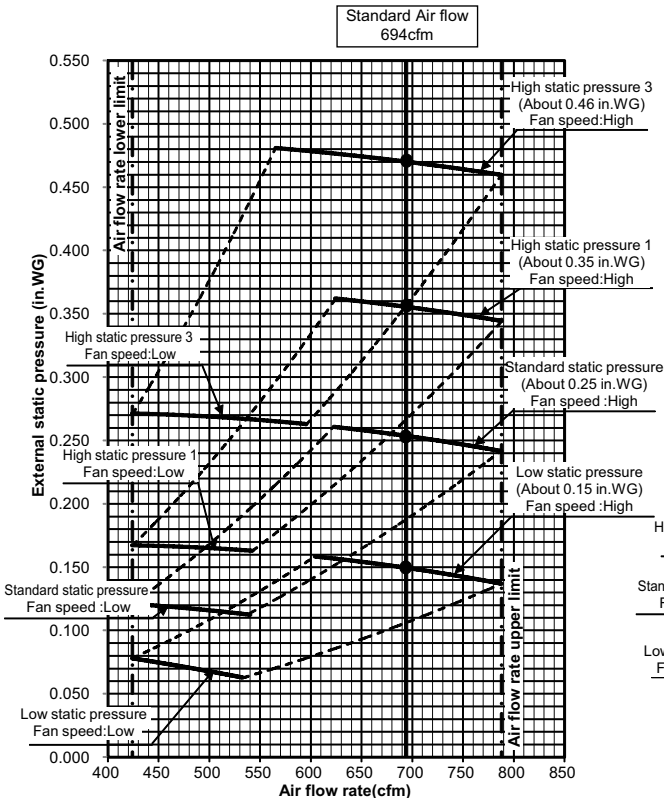

MMD-AP0364BH2UL-1

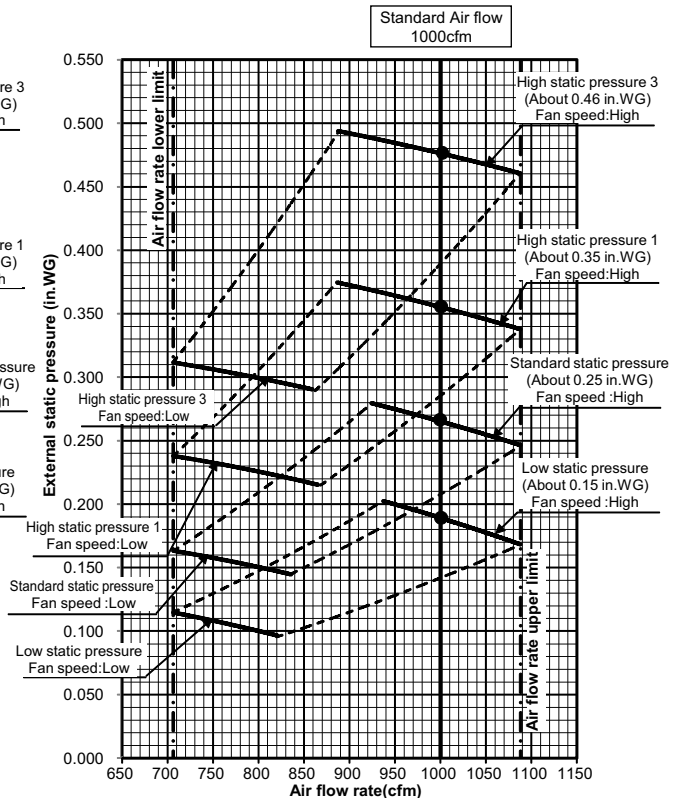

Rear suction (No filter)

MMD-AP0424BH2UL-1, MMD-AP0484BH2UL-1

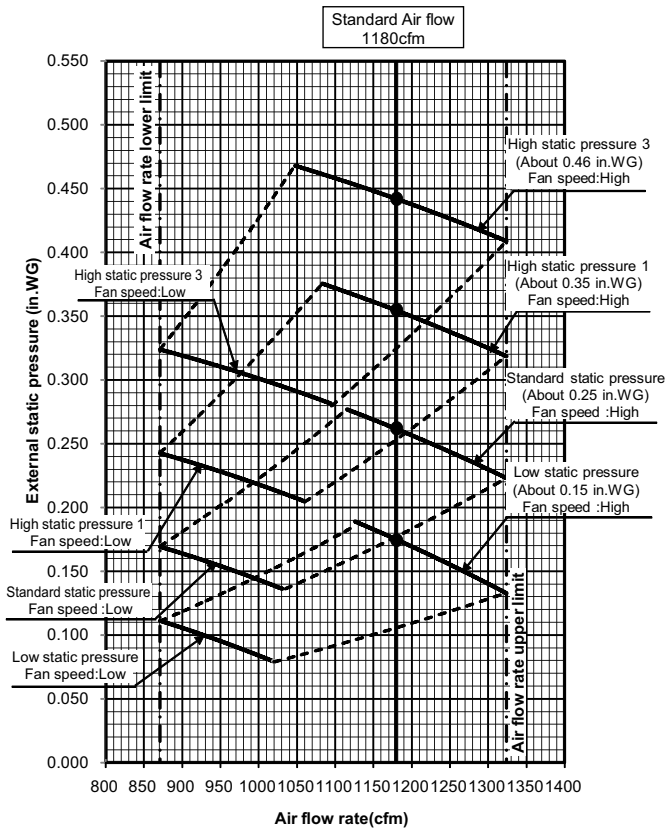

Underside suction (No filter)

MMD-AP0074BH2UL-1, MMD-AP0094BH2UL-1  
MMD-AP0124BH2UL-1

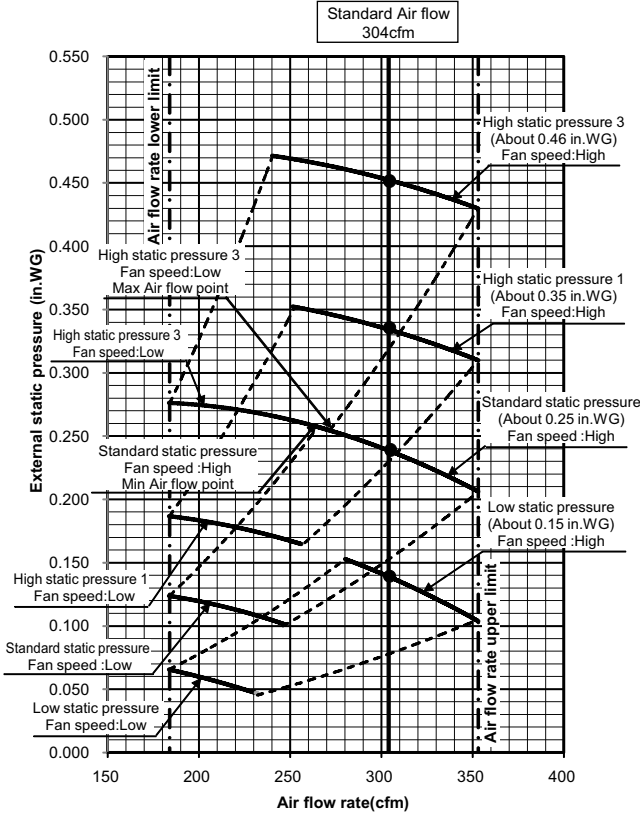

MMD-AP0154BH2UL-1, MMD-AP0184BH2UL-1

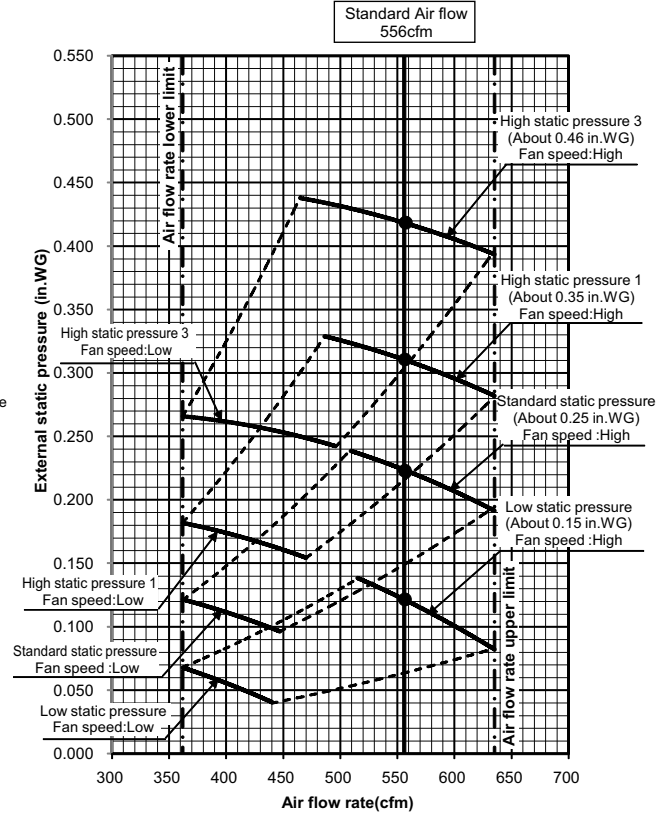

MMD-AP0214BH2UL-1, MMD-AP0244BH2UL-1  
MMD-AP0304BH2UL-1

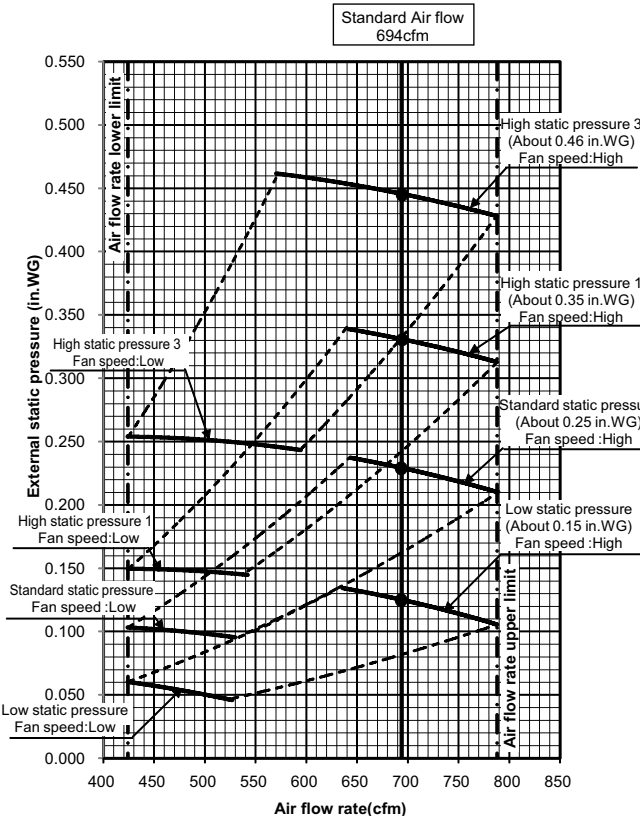

MMD-AP0364BH2UL-1

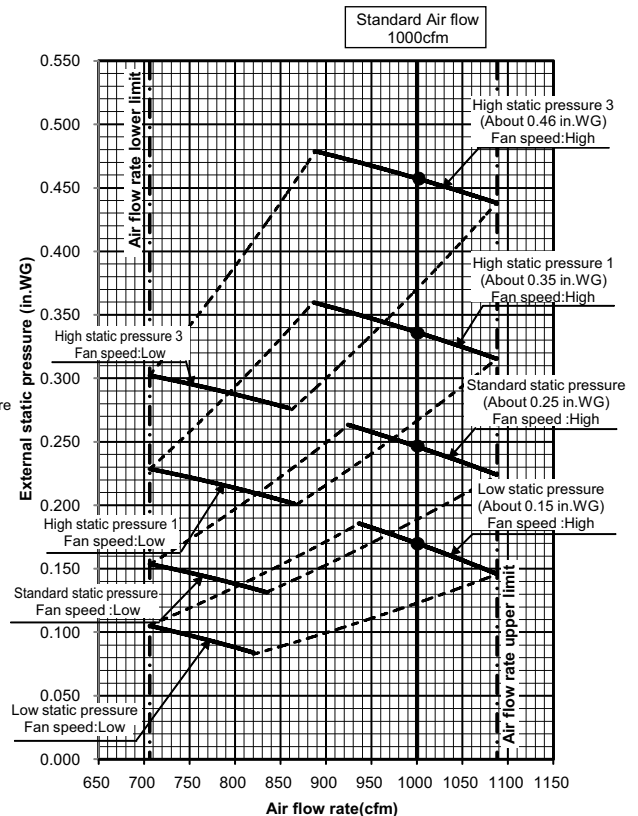

Underside suction (No filter)

MMD-AP0424BH2UL-1, MMD-AP0484BH2UL-1

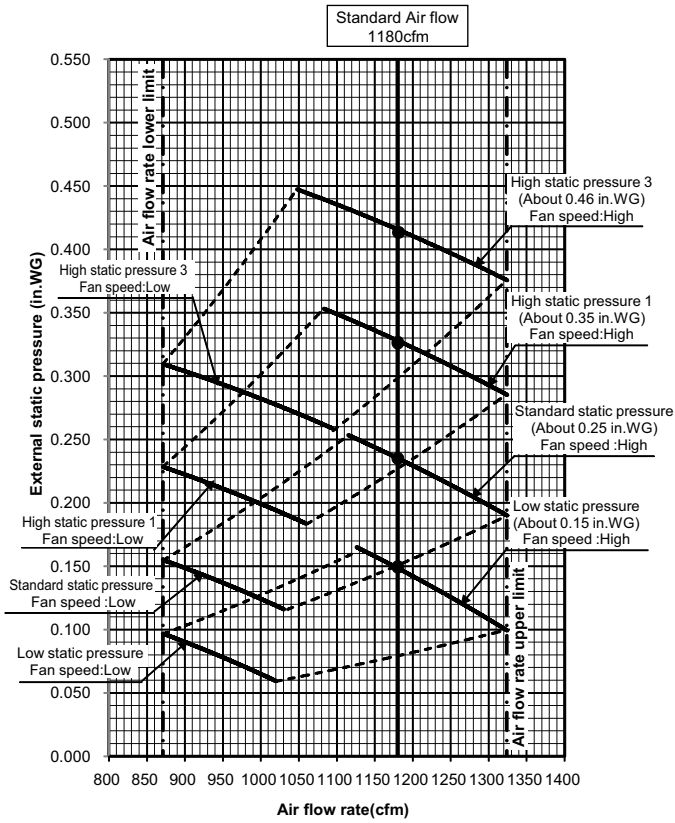

9. Sound data

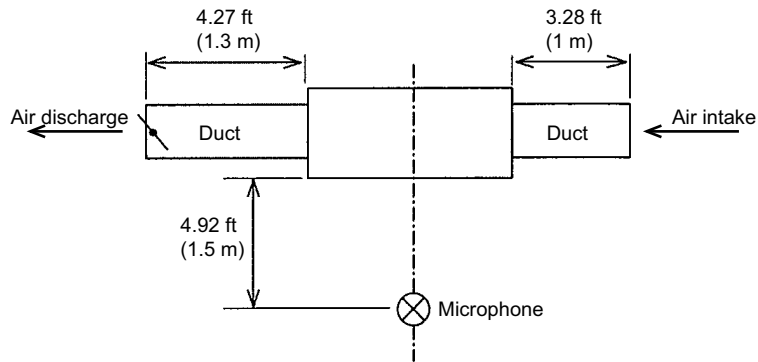

**MMD-AP0074BH2UL-1 (230V)**  
**MMD-AP0094BH2UL-1 (230V)**  
**MMD-AP0124BH2UL-1 (230V)**

External static pressure	61.8 (Pa)	45.1 (Pa)	34.3 (Pa)
Sound pressure level (dB(A))	33	30	27

**MMD-AP0154BH2UL-1 (230V)**  
**MMD-AP0184BH2UL-1 (230V)**

External static pressure	61.8 (Pa)	41.2 (Pa)	26.5 (Pa)
Sound pressure level (dB(A))	37	35	31

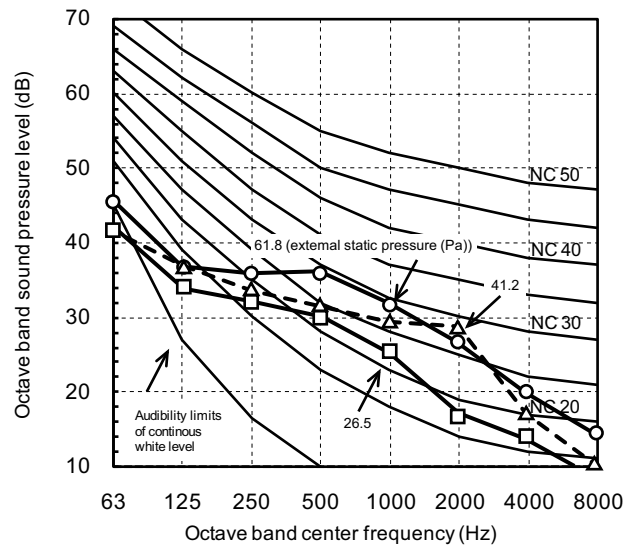
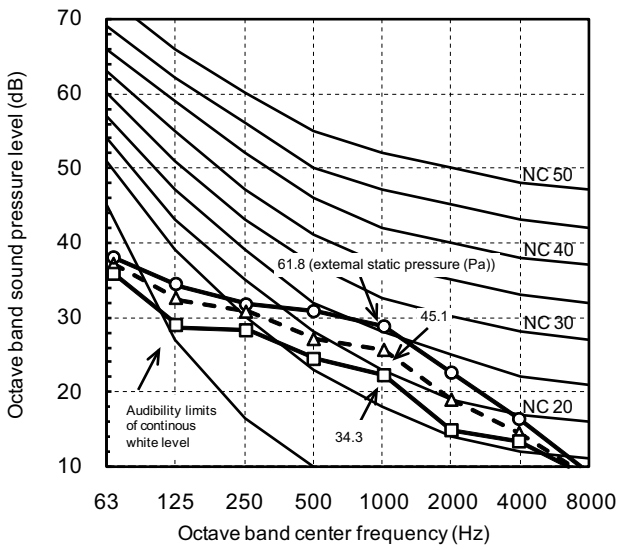

**MMD-AP0214BH2UL-1 (230V)**  
**MMD-AP0244BH2UL-1 (230V)**  
**MMD-AP0304BH2UL-1 (230V)**

External static pressure	62.8 (Pa)	44.1 (Pa)	36.3 (Pa)
Sound pressure level (dB(A))	37	35	34

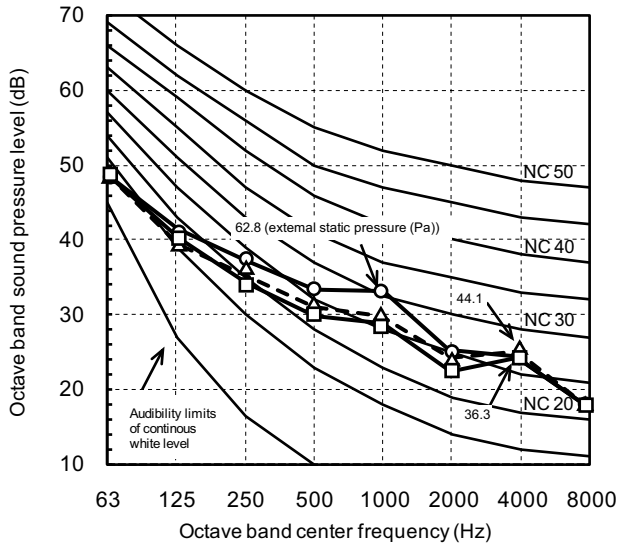

**MMD-AP0364BH2UL-1 (230V)**

External static pressure	61.8 (Pa)	50.0 (Pa)	39.2 (Pa)
Sound pressure level (dB(A))	41	39	37

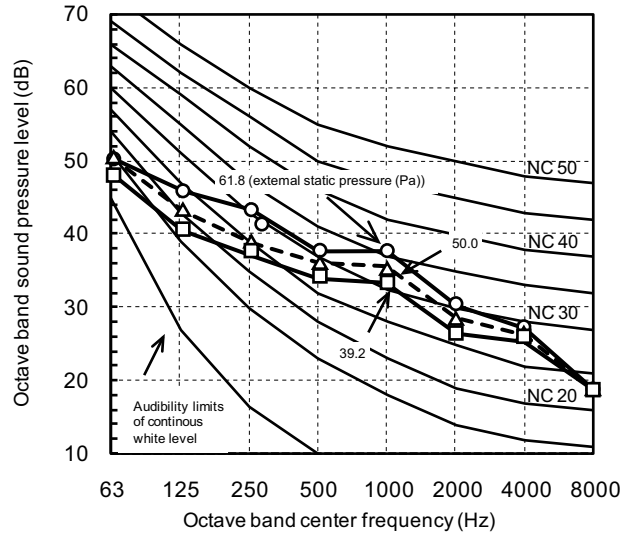

**MMD-AP0424BH2UL-1 (230V)**  
**MMD-AP0484BH2UL-1 (230V)**

External static pressure	62.8 (Pa)	50.9 (Pa)	40.2 (Pa)
Sound pressure level (dB(A))	42	40	38

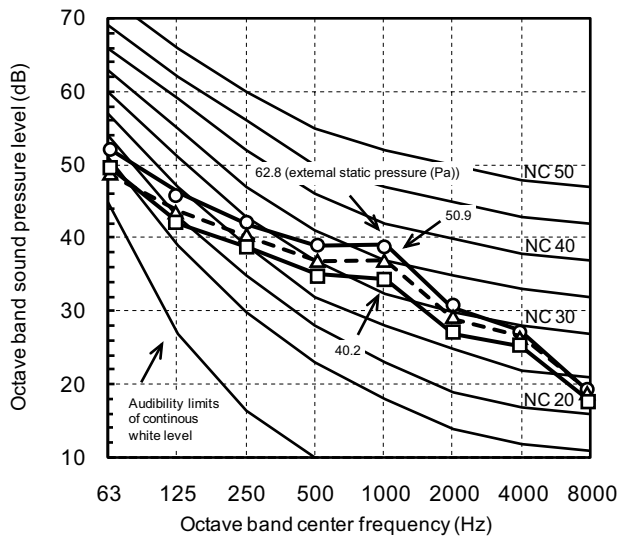

**10. Accessories**

Optional part for Medium Static Ducted type

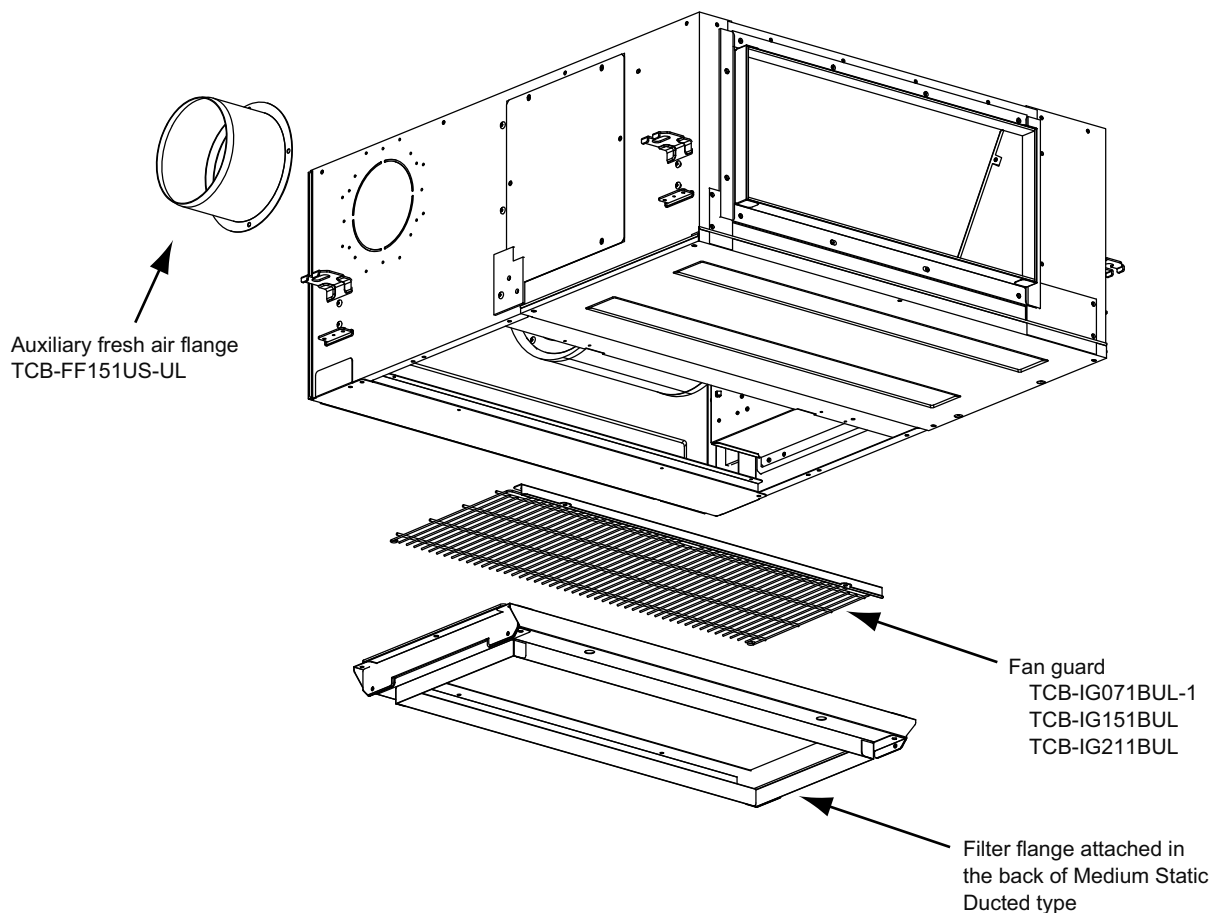

Parts Name	Model name	Applied Model	Note
Fan guard	TCB-IG071BUL-1	MMD-AP0074 to 0124BH2UL-1	For underside suction
	TCB-IG151BUL	MMD-AP0154 to 0184BH2UL-1	
	TCB-IG211BUL	MMD-AP0214 to 0484BH2UL-1	
Auxiliary fresh air flange	TCB-FF151US-UL	MMD-AP0074 to 0484BH2UL-1	-



## 11. Reference

### 11-1 Fan guard

#### Preparation before installation

Remove a fixing screw for shipping from the cover plate of the filter rack, and block the screw hole with tape.

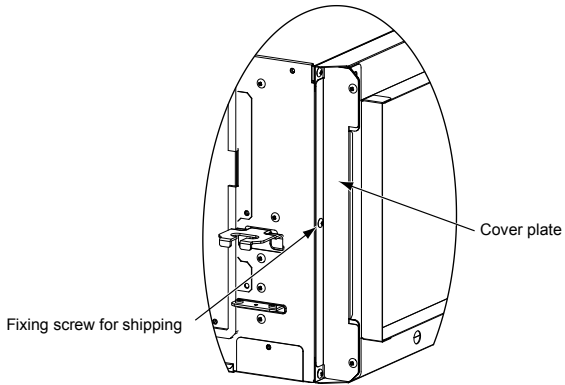

#### Arranging the under intake type

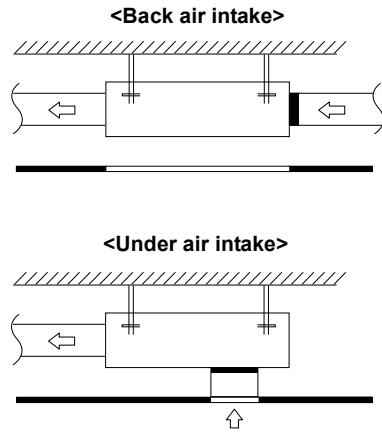

### CAUTION

For air intake from under air intake, be sure to attach a separately-sold fan guard.

Model	MMD-	AP0074 to AP0124BH2UL-1	AP0154 to AP0184BH2UL-1	AP0214 to AP0484BH2UL-1
FAN-GUARD	model name	TCB-IG071BUL-1	TCB-IG151BUL	TCB-IG211BUL

For air intake from under air intake, replace the cover (A) and filter flange as shown below before installing the unit.

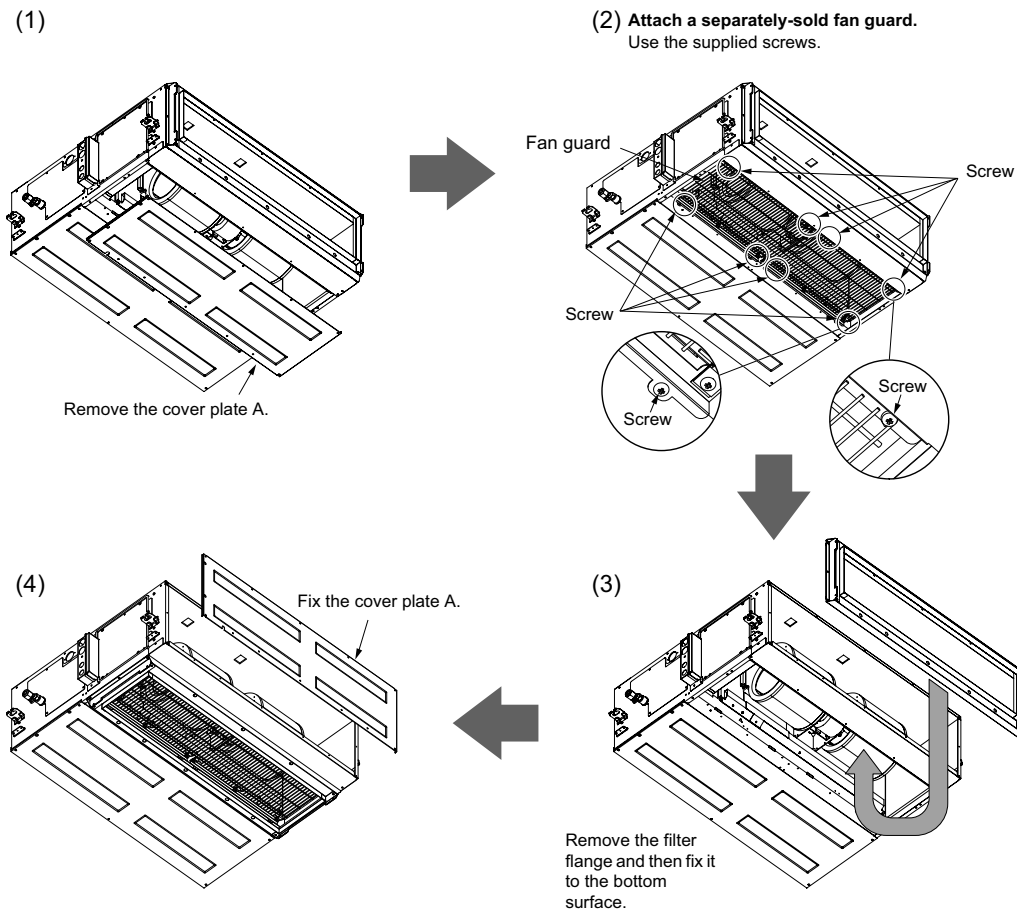

### 11-2 Auxiliary fresh air flange

Arrange a flexible duct (locally procured).  
It is necessary to install auxiliary fresh air flange.

#### INSTALLATION PROCEDURE

- 1 Using the knockout of the indoor unit, as a marker, cut off the steel plate with cutting pliers or cutter.
- 2 Install the auxiliary fresh air flange to the indoor unit with attached 4 fixing screws.

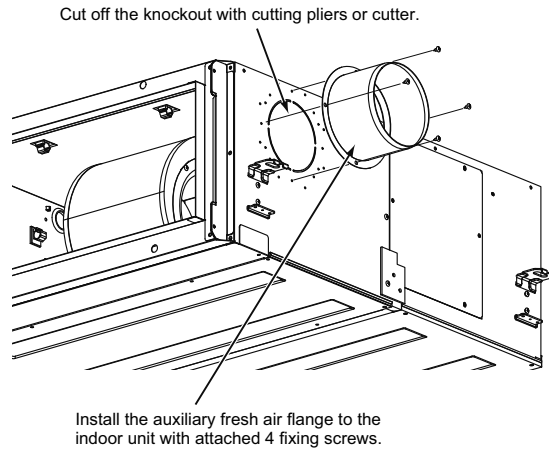

#### CAUTION

The fresh air shall be conditioned by heat reclaim ventilator or similar.  
Emsure the fresh air volume is determined so that mixed suction air and fresh air maintain the operating temperature.  
Recommended conditioned air temperature is 53.6F to 86F.  
however, make a fresh air volume within 10% of standard.

<b>Model name</b>	MMD-0074BH2UL-1 0094BH2UL-1 0124BH2UL-1	0154BH2UL-1 0184BH2UL-1	0214BH2UL-1 0244BH2UL-1 0304BH2UL-1	0364BH2UL-1	0424BH2UL-1 0484BH2UL-1
<b>Standard air flow</b> (cfm)	304	556	694	1000	1180

Provide an air filter in fresh air duct. (Fresh air doesn't pass through the filter of indoor unit.)  
Besure to insulate fresh air duct.  
Please wire for inter-lock with fan of indoor unit.

MMD-AP0074BH2UL-1/AP0094BH2UL-1/AP0124BH2UL-1

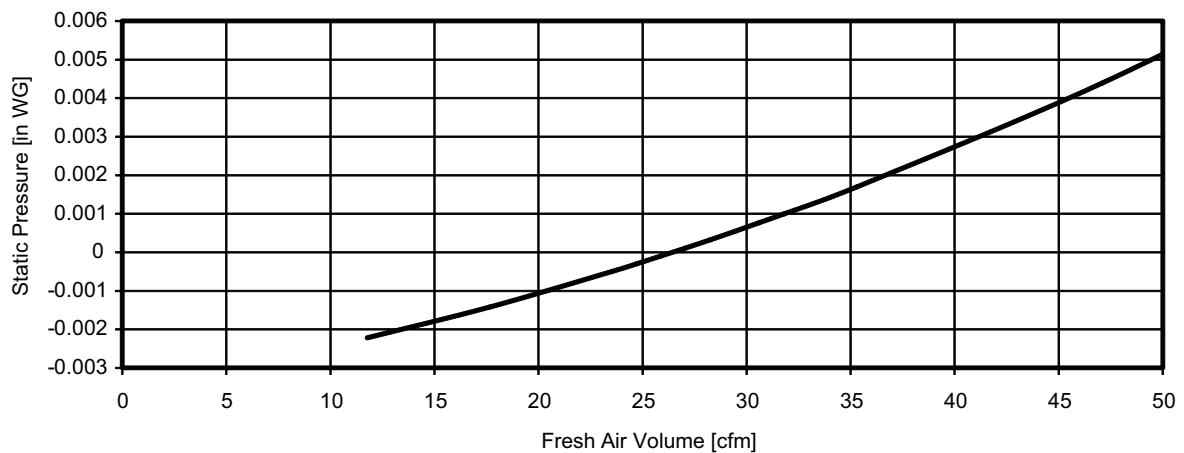

MMD-AP0154BH2UL-1/AP0184BH2UL-1

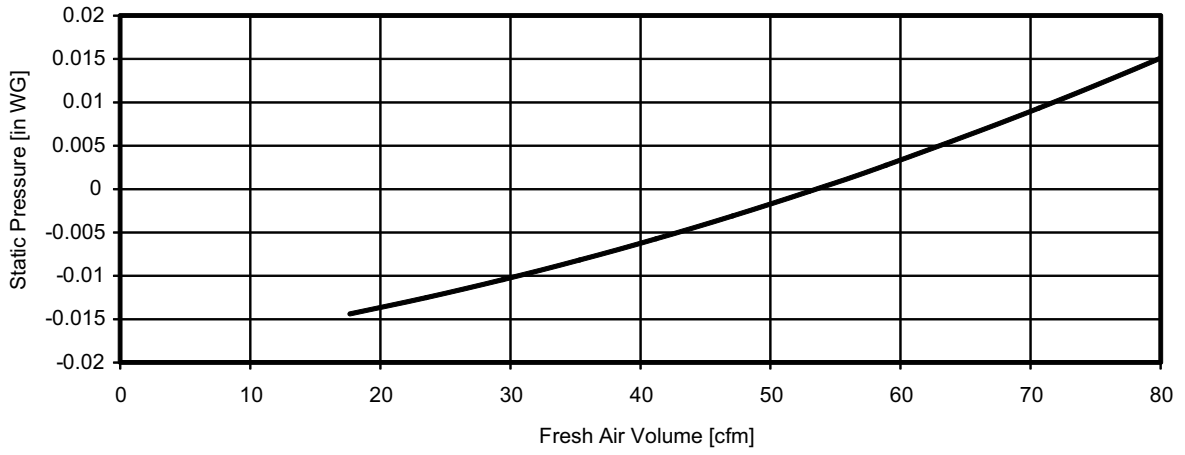

MMD-AP0214BH2UL-1/AP0244BH2UL-1/AP0304BH2UL-1/  
AP0364BH2UL-1/AP0424BH2UL-1/AP0484BH2UL-1

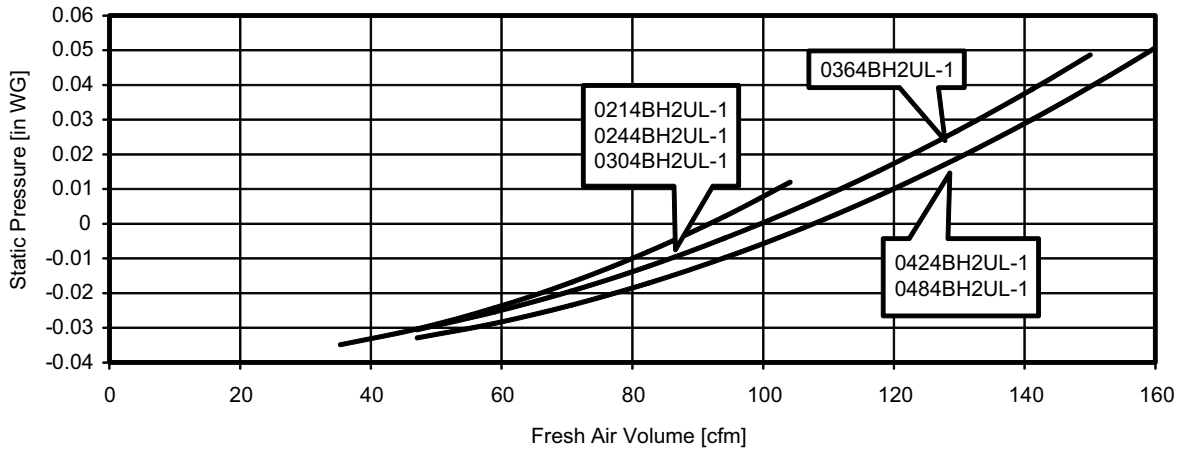

---

---

## **Medium Static Ducted Type Engineering Data Book**

**Model name:**

**MMD-AP\_\_\_4BH2UL-1**

**March, 2016 First Edition**

**TOSHIBA CARRIER CORPORATION**