

Floor console exposed Type

MML-AP0074H2UL / MML-AP0094H2UL
MML-AP0124H2UL / MML-AP0154H2UL
MML-AP0184H2UL / MML-AP0244H2UL

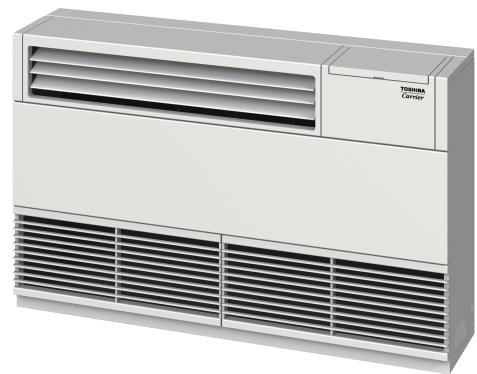

Contents

1. Specifications
2. Dimensions
3. Center of gravity
4. Piping diagram
5. Wiring diagram
6. Electrical characteristics
7. Sensible capacity table
8. Air flow distance chart
9. Sound data

1. Specifications

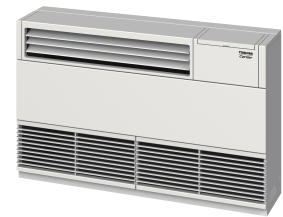

Model name			MML-	AP0074H2UL	AP0094H2UL	AP0124H2UL	AP0154H2UL	AP0184H2UL	AP0244H2UL
Cooling capacity			kBtu/h	7.5	9.5	12.0	15.4	18.0	24.0
Heating capacity			kBtu/h	8.5	10.5	13.5	17.0	20.0	27.0
Electrical characteristics	Power supply		230V (208V/230V) 1 phase 60Hz						
	Power consumption	208V	kW	0.049	0.049	0.080	0.080	0.098	0.098
		230V	kW	0.058	0.058	0.093	0.093	0.113	0.113
Appearance			Silky shade (Munsell 1Y8.5/0.5)						
Dimension	Unit	Height	In	24.8	24.8	24.8	24.8	24.8	24.8
		Width	In	37.4	37.4	37.4	37.4	37.4	37.4
		Depth	In	9.1	9.1	9.1	9.1	9.1	9.1
	Packing	Height	In	29.0	29.0	29.0	29.0	29.0	29.0
		Width	In	41.3	41.3	41.3	41.3	41.3	41.3
		Depth	In	12.9	12.9	12.9	12.9	12.9	12.9
Total weight	Unit		lbs	81.6	81.6	81.6	81.6	88.2	88.2
	Packing		lbs	88.2	88.2	88.2	88.2	94.8	94.8
Heat exchanger			Finned tube						
Fan unit	Fan		Centrifugal fan						
	Standard air flow (High/Mid./Low)		cfm	280 / 250 / 210	280 / 250 / 210	530 / 460 / 380	530 / 460 / 380	640 / 550 / 460	640 / 550 / 460
	Motor		W	19	19	45	45	70	70
Connecting pipe	Gas side		In	3/8"	3/8"	3/8"	1/2"	1/2"	5/8"
	Liquid side		In	1/4"	1/4"	1/4"	1/4"	1/4"	3/8"
	Drain port (Nominal dia. mm)		20 (Polyvinyl chloride tube)						
Sound pressure level (High/Mid./Low) (*1)	208V	dB(A)	39 / 38 / 35	39 / 38 / 35	47 / 44 / 40	47 / 44 / 40	51 / 46 / 41	51 / 46 / 41	
	230V	dB(A)	42 / 40 / 38	42 / 40 / 38	50 / 46 / 42	50 / 46 / 42	53 / 48 / 43	53 / 48 / 43	

Note

(*1) The actual values in an external operating environment are generally higher than the indicated values due to the contribution from ambient noise.

2. Dimensions

MML-AP0074H2UL, AP0094H2UL, AP0124H2UL

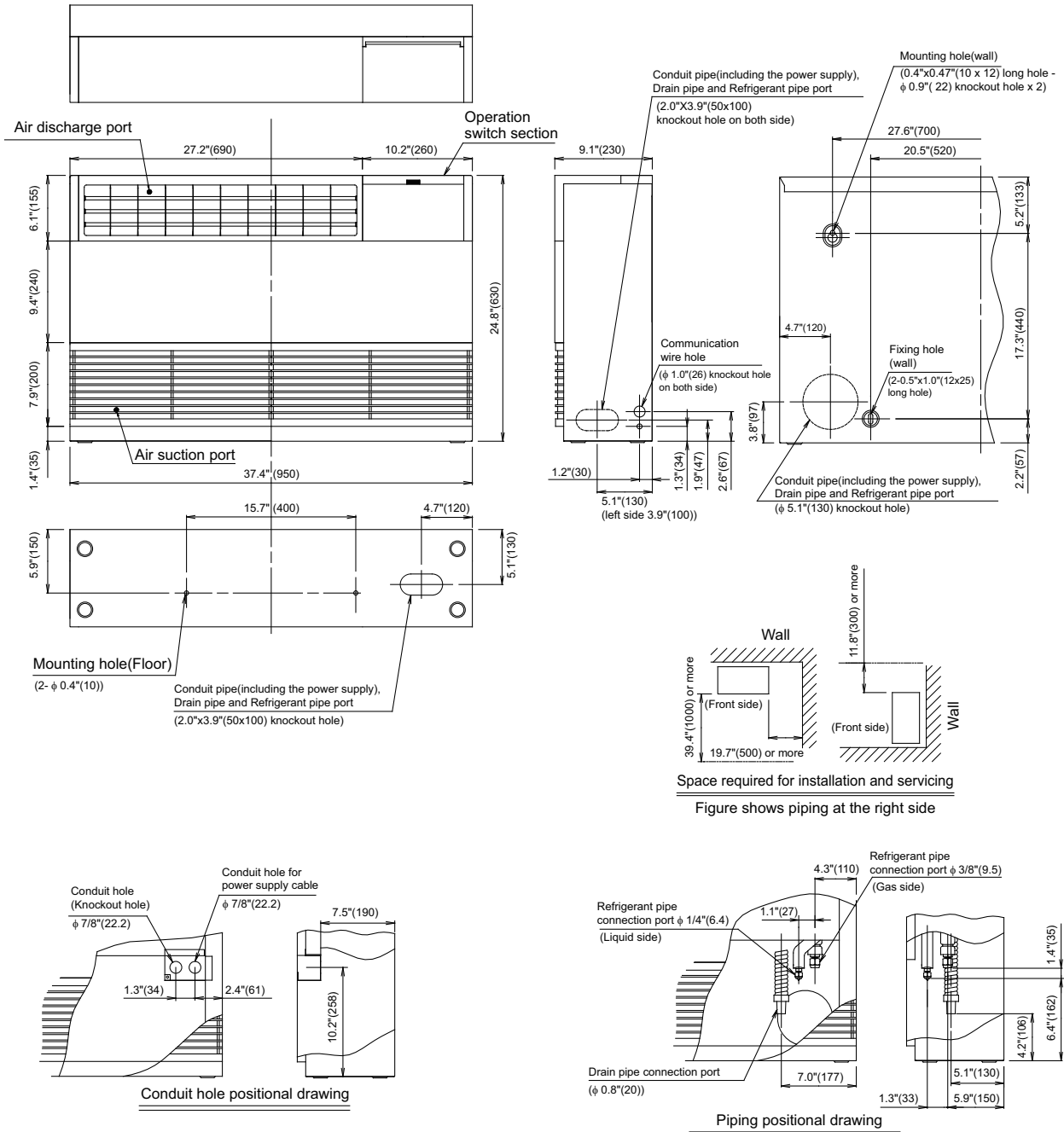

MML-AP0154H2UL, AP0184H2UL

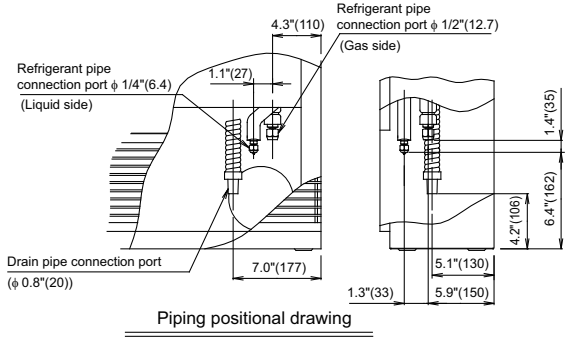
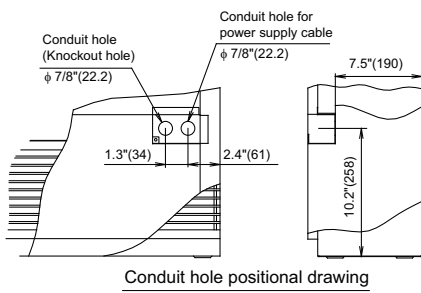
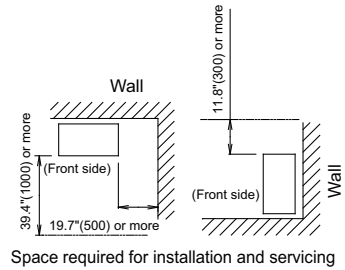
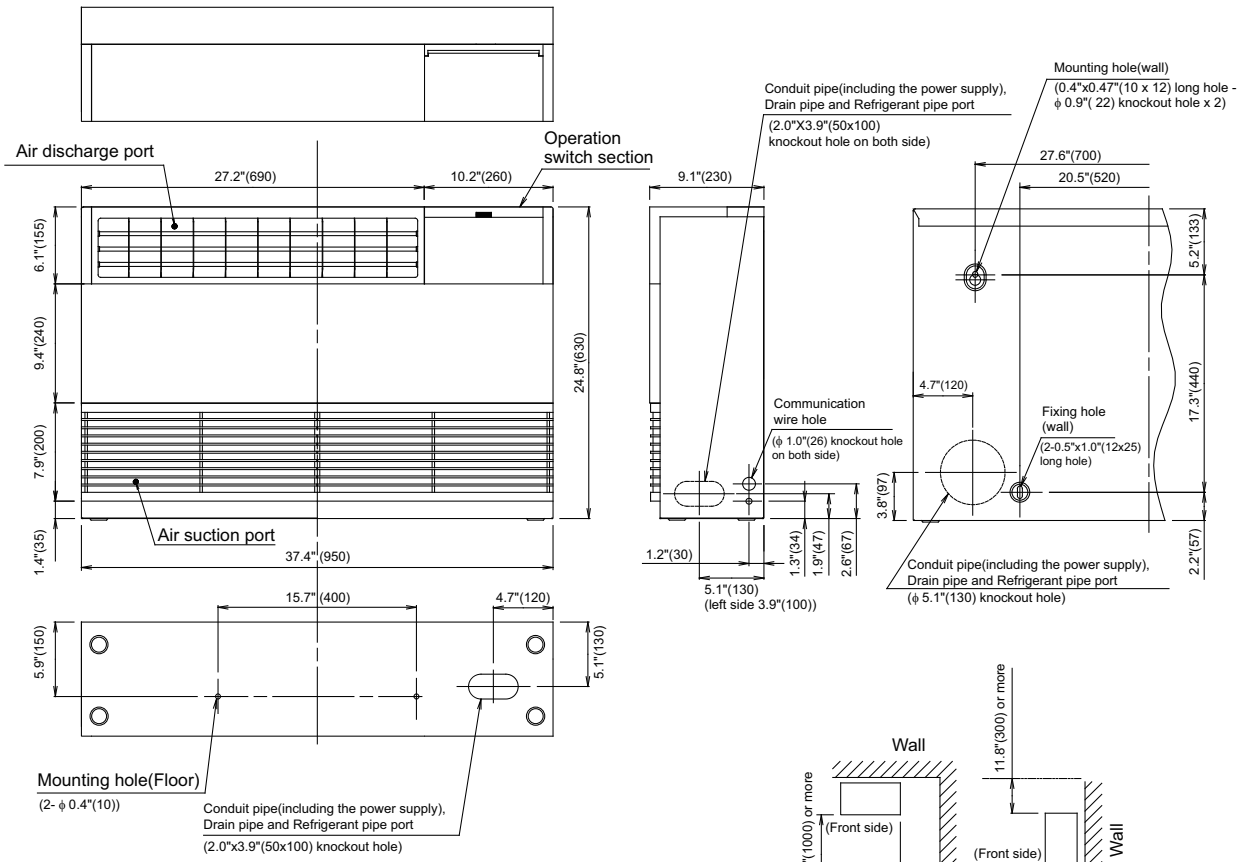

MML-AP0244H2UL

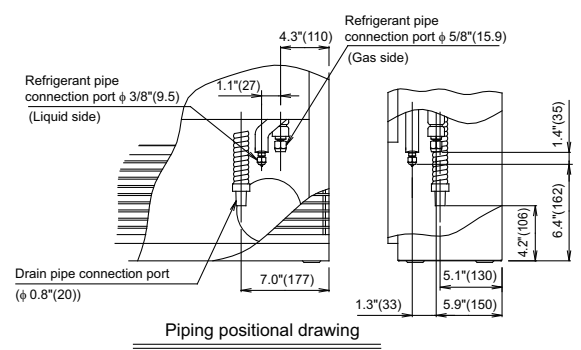
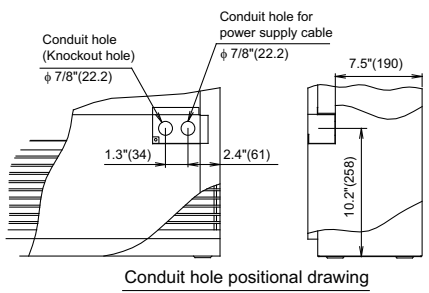
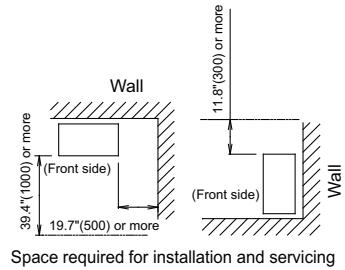
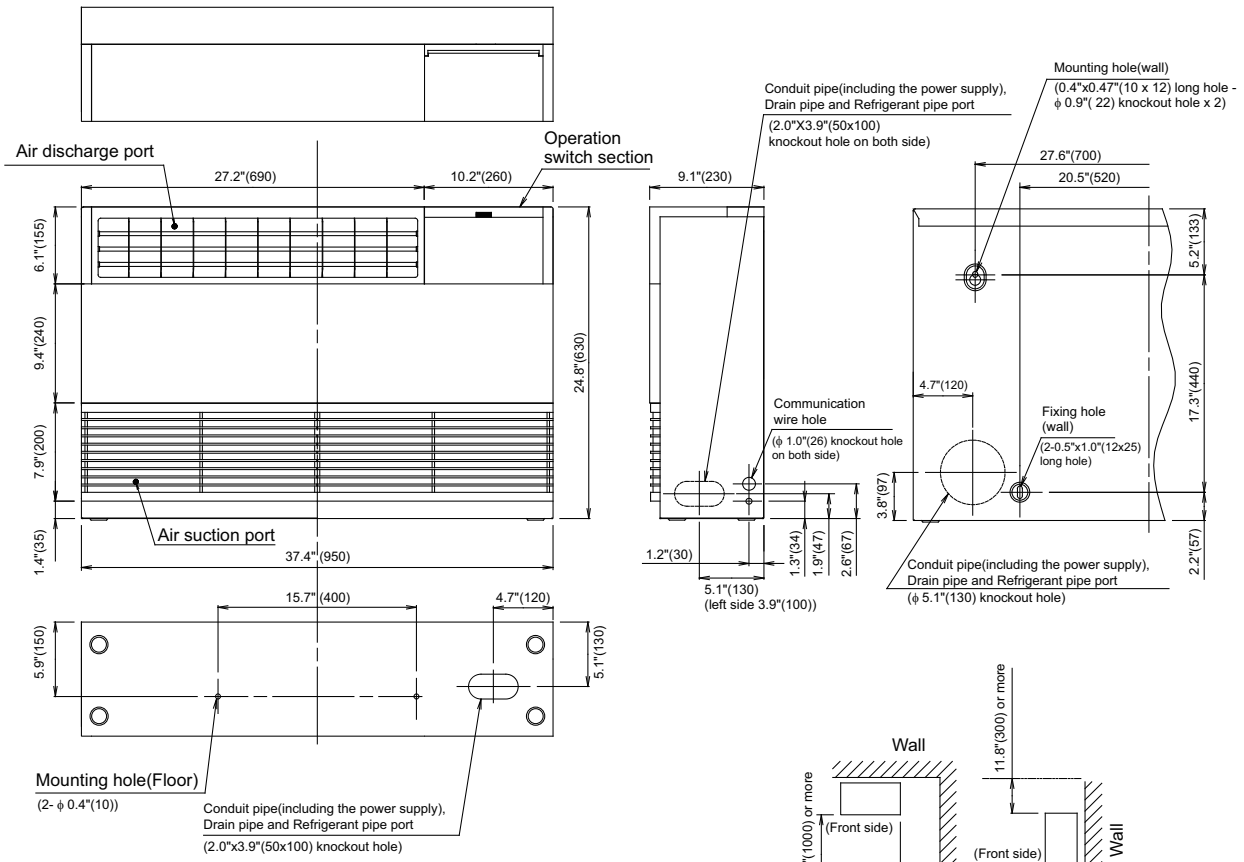

3. Center of gravity

Model name	Total weight (lbs)
MML-AP0074H2UL	88.2
MML-AP0094H2UL	
MML-AP0124H2UL	
MML-AP0154H2UL	94.8
MML-AP0184H2UL	
MML-AP0244H2UL	

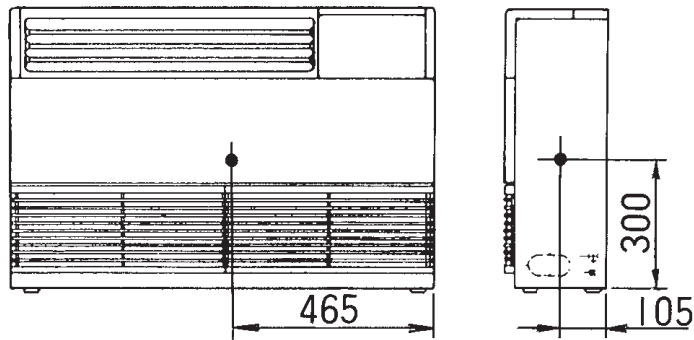

4. Piping diagram

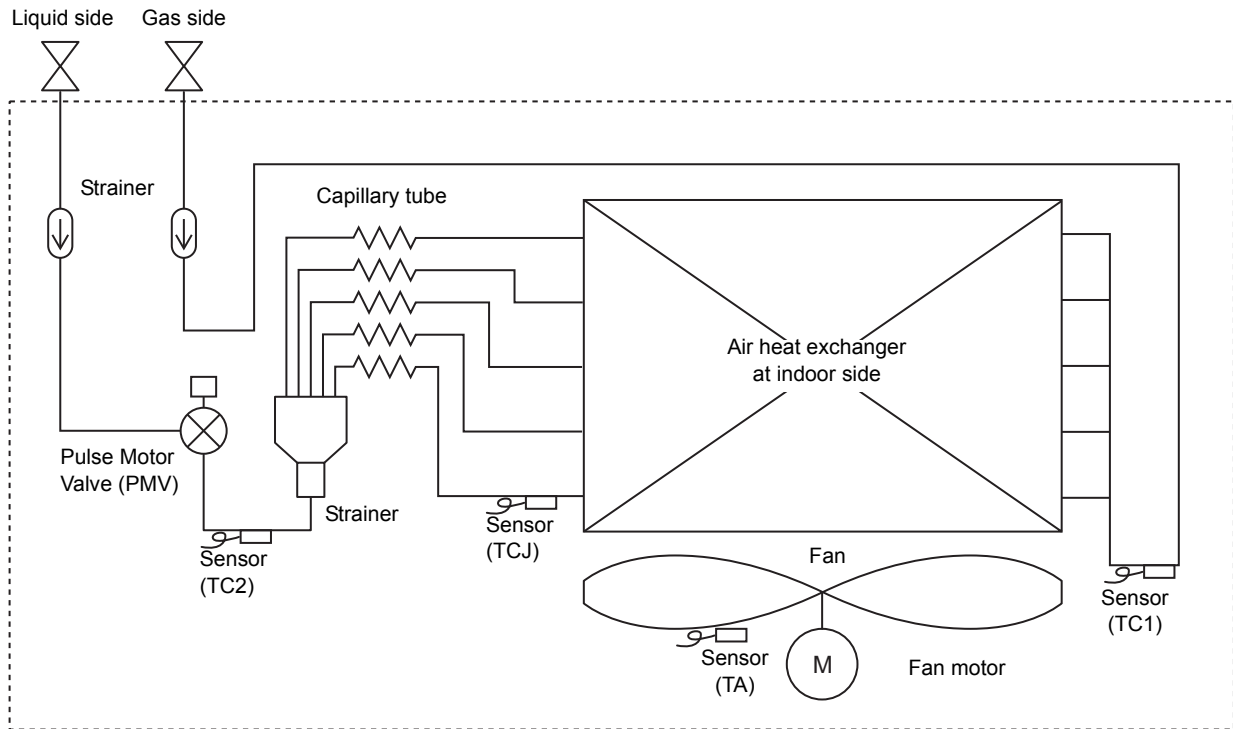

Functional part name		Functional outline
Pulse Motor Valve	PMV	(Connector CN082 (6P): Blue) 1) Controls super heat in cooling operation 2) Controls sub cool in heating operation 3) Recovers refrigerant oil in cooling operation 4) Recovers refrigerant oil in heating operation
Temp. sensor	1. TA	(Connector CN104 (2P): Yellow) 1) Detects indoor suction temperature
	2. TC1	(Connector CN100 (3P): Brown) 1) Controls PMV super heat in cooling operation
	3. TC2	(Connector CN101 (2P): Black) 1) Controls PMV sub cool in heating operation
	4. TCJ	(Connector CN102 (2P): Red) 1) Controls PMV super heat in cooling operation

5. Wiring diagram

MML-AP0074H2UL, AP0094H2UL, AP0124H2UL, AP0154H2UL, AP0184H2UL, AP0244H2UL

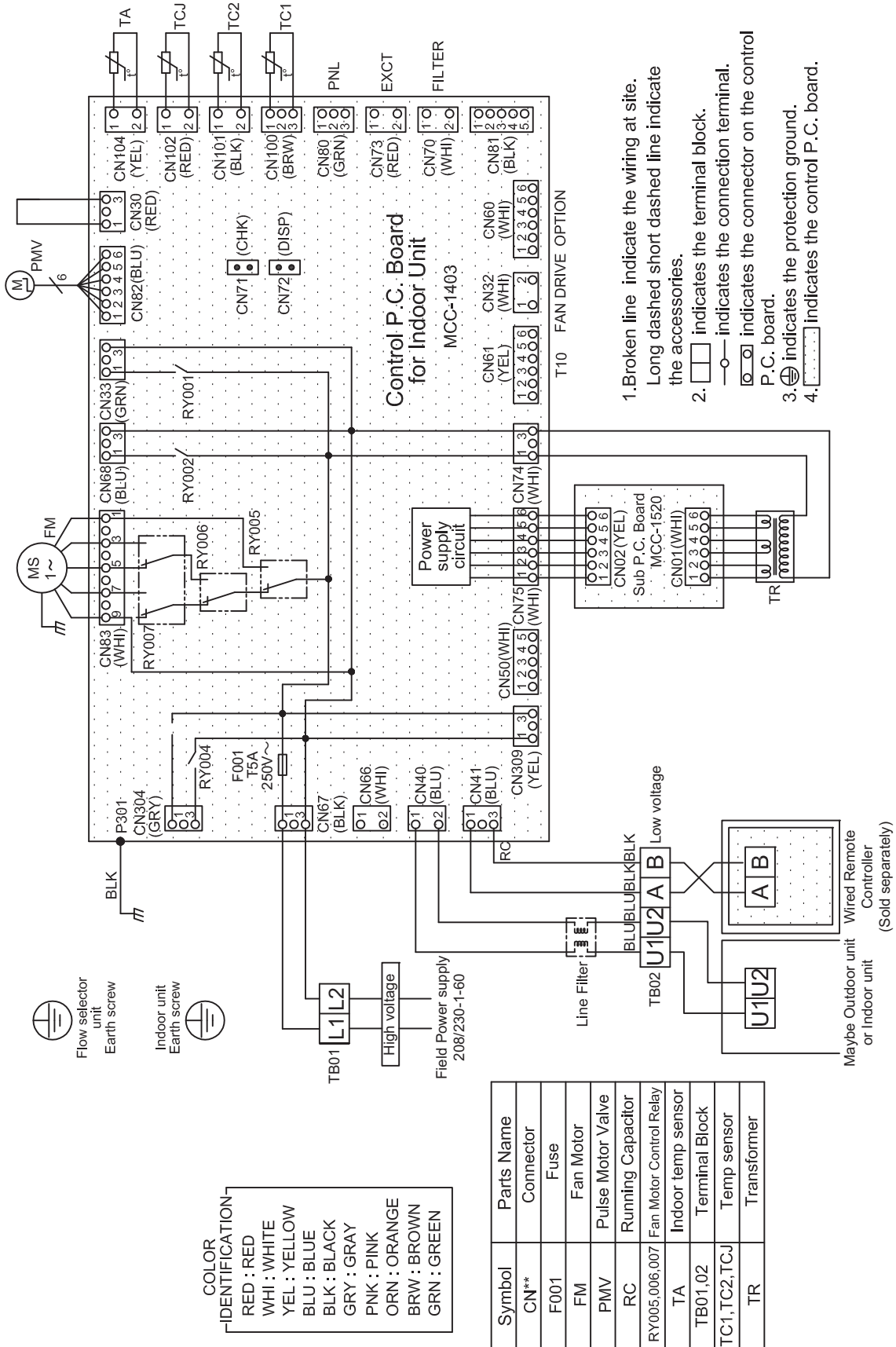

6. Electrical characteristics

Type	Model	Nominal Voltage (V-Ph-Hz)	Voltage Range (A)		Power consumption	FLA	MCA	MOCP
			Min	Max	kw	A	A	A
Floor Console Exposed Type	MML-AP0074H2UL	208/230-1-60	187	253	0.049/0.058	0.3	0.4	15
	MML-AP0094H2UL	208/230-1-60	187	253	0.049/0.058	0.3	0.4	15
	MML-AP0124H2UL	208/230-1-60	187	253	0.080/0.093	0.5	0.6	15
	MML-AP0154H2UL	208/230-1-60	187	253	0.080/0.093	0.5	0.6	15
	MML-AP0184H2UL	208/230-1-60	187	253	0.098/0.113	0.6	0.7	15
	MML-AP0244H2UL	208/230-1-60	187	253	0.098/0.113	0.6	0.7	15

MCA: Minimum Circuit Amps

MOCP: Maximum Overcurrent Protection (Amps)

FLA : Full Load Amps

kW : Fan Motor Rated Output (kW)

7. Sensible capacity table

Floor console exposed Type (MML-AP__4H2UL)

unit size	outdoor air temp. °FDB	indoor air temp.													
		59°FWB		61°FWB		64°FWB		67°FWB		68°FWB		72°FWB		75°FWB	
		71°FDB		73°FDB		77°FDB		80°FDB		82°FDB		86°FDB		90°FDB	
		TC	SHC	TC	SHC	TC	SHC	TC	SHC	TC	SHC	TC	SHC	TC	SHC
007	50	6380	4320	6680	4440	7100	4620	7500	4770	7630	4780	8110	4720	8450	4550
	54	6380	4320	6680	4440	7100	4620	7500	4770	7630	4780	8110	4720	8450	4550
	57	6380	4320	6680	4440	7100	4620	7500	4770	7630	4780	8110	4720	8450	4550
	61	6380	4320	6680	4440	7100	4620	7500	4770	7630	4780	8110	4720	8450	4550
	64	6380	4320	6680	4440	7100	4620	7500	4770	7630	4780	8110	4720	8450	4550
	68	6380	4320	6680	4440	7100	4620	7500	4770	7630	4780	8110	4720	8450	4550
	70	6380	4320	6680	4440	7100	4620	7500	4770	7630	4780	8110	4720	8450	4550
	73	6380	4320	6680	4440	7100	4620	7500	4770	7630	4780	8110	4720	8450	4550
	77	6380	4320	6680	4440	7100	4620	7500	4770	7630	4780	8110	4720	8450	4550
	81	6380	4320	6680	4440	7100	4620	7500	4770	7630	4780	8110	4720	8450	4550
	84	6380	4320	6680	4440	7100	4620	7500	4770	7630	4780	8110	4720	8450	4550
	88	6380	4320	6680	4440	7100	4620	7500	4770	7630	4780	8110	4720	8450	4550
	91	6380	4320	6680	4440	7100	4620	7500	4770	7630	4780	8110	4720	8450	4550
95	6380	4320	6680	4440	7100	4620	7500	4770	7630	4780	8110	4720	8450	4550	
99	6190	4190	6490	4310	6890	4490	7280	4630	7410	4640	7870	4580	8200	4420	
102	6050	4100	6330	4210	6730	4380	7110	4520	7230	4530	7690	4470	8010	4310	
009	50	8090	4930	8460	5060	9000	5270	9500	5430	9660	5440	10270	5370	10700	5180
	54	8090	4930	8460	5060	9000	5270	9500	5430	9660	5440	10270	5370	10700	5180
	57	8090	4930	8460	5060	9000	5270	9500	5430	9660	5440	10270	5370	10700	5180
	61	8090	4930	8460	5060	9000	5270	9500	5430	9660	5440	10270	5370	10700	5180
	64	8090	4930	8460	5060	9000	5270	9500	5430	9660	5440	10270	5370	10700	5180
	68	8090	4930	8460	5060	9000	5270	9500	5430	9660	5440	10270	5370	10700	5180
	70	8090	4930	8460	5060	9000	5270	9500	5430	9660	5440	10270	5370	10700	5180
	73	8090	4930	8460	5060	9000	5270	9500	5430	9660	5440	10270	5370	10700	5180
	77	8090	4930	8460	5060	9000	5270	9500	5430	9660	5440	10270	5370	10700	5180
	81	8090	4930	8460	5060	9000	5270	9500	5430	9660	5440	10270	5370	10700	5180
	84	8090	4930	8460	5060	9000	5270	9500	5430	9660	5440	10270	5370	10700	5180
	88	8090	4930	8460	5060	9000	5270	9500	5430	9660	5440	10270	5370	10700	5180
	91	8090	4930	8460	5060	9000	5270	9500	5430	9660	5440	10270	5370	10700	5180
95	8090	4930	8460	5060	9000	5270	9500	5430	9660	5440	10270	5370	10700	5180	
99	7860	4790	8210	4910	8740	5120	9220	5270	9380	5280	9970	5210	10390	5030	
102	7670	4670	8020	4800	8530	5000	9010	5150	9160	5160	9740	5090	10140	4910	
012	50	10210	6640	10690	6830	11360	7100	12000	7330	12210	7350	12980	7260	13510	6980
	54	10210	6640	10690	6830	11360	7100	12000	7330	12210	7350	12980	7260	13510	6980
	57	10210	6640	10690	6830	11360	7100	12000	7330	12210	7350	12980	7260	13510	6980
	61	10210	6640	10690	6830	11360	7100	12000	7330	12210	7350	12980	7260	13510	6980
	64	10210	6640	10690	6830	11360	7100	12000	7330	12210	7350	12980	7260	13510	6980
	68	10210	6640	10690	6830	11360	7100	12000	7330	12210	7350	12980	7260	13510	6980
	70	10210	6640	10690	6830	11360	7100	12000	7330	12210	7350	12980	7260	13510	6980
	73	10210	6640	10690	6830	11360	7100	12000	7330	12210	7350	12980	7260	13510	6980
	77	10210	6640	10690	6830	11360	7100	12000	7330	12210	7350	12980	7260	13510	6980
	81	10210	6640	10690	6830	11360	7100	12000	7330	12210	7350	12980	7260	13510	6980
	84	10210	6640	10690	6830	11360	7100	12000	7330	12210	7350	12980	7260	13510	6980
	88	10210	6640	10690	6830	11360	7100	12000	7330	12210	7350	12980	7260	13510	6980
	91	10210	6640	10690	6830	11360	7100	12000	7330	12210	7350	12980	7260	13510	6980
95	10210	6640	10690	6830	11360	7100	12000	7330	12210	7350	12980	7260	13510	6980	
99	9910	6450	10380	6630	11030	6890	11650	7120	11860	7140	12600	7050	13120	6780	
102	9680	6290	10130	6470	10770	6730	11380	6950	11580	6970	12310	6880	12810	6620	

TC : Total capacity [Btu/h]
 SHC : Sensible capacity [Btu/h]

Floor console exposed Type (MML-AP__4H2UL)

unit size	outdoor air temp. °FDB	indoor air temp.													
		59°FWB		61°FWB		64°FWB		67°FWB		68°FWB		72°FWB		75°FWB	
		71°FDB		73°FDB		77°FDB		80°FDB		82°FDB		86°FDB		90°FDB	
		TC	SHC	TC	SHC	TC	SHC	TC	SHC	TC	SHC	TC	SHC	TC	SHC
015	50	13110	8690	13710	8920	14580	9290	15400	9580	15660	9600	16660	9490	17340	9130
	54	13110	8690	13710	8920	14580	9290	15400	9580	15660	9600	16660	9490	17340	9130
	57	13110	8690	13710	8920	14580	9290	15400	9580	15660	9600	16660	9490	17340	9130
	61	13110	8690	13710	8920	14580	9290	15400	9580	15660	9600	16660	9490	17340	9130
	64	13110	8690	13710	8920	14580	9290	15400	9580	15660	9600	16660	9490	17340	9130
	68	13110	8690	13710	8920	14580	9290	15400	9580	15660	9600	16660	9490	17340	9130
	70	13110	8690	13710	8920	14580	9290	15400	9580	15660	9600	16660	9490	17340	9130
	73	13110	8690	13710	8920	14580	9290	15400	9580	15660	9600	16660	9490	17340	9130
	77	13110	8690	13710	8920	14580	9290	15400	9580	15660	9600	16660	9490	17340	9130
	81	13110	8690	13710	8920	14580	9290	15400	9580	15660	9600	16660	9490	17340	9130
	84	13110	8690	13710	8920	14580	9290	15400	9580	15660	9600	16660	9490	17340	9130
	88	13110	8690	13710	8920	14580	9290	15400	9580	15660	9600	16660	9490	17340	9130
	91	13110	8690	13710	8920	14580	9290	15400	9580	15660	9600	16660	9490	17340	9130
95	13110	8690	13710	8920	14580	9290	15400	9580	15660	9600	16660	9490	17340	9130	
99	12730	8440	13310	8660	14160	9020	14950	9300	15210	9320	16180	9210	16840	8870	
102	12430	8240	13000	8460	13820	8810	14600	9080	14850	9100	15790	9000	16440	8660	
018	50	15320	10200	16030	10480	17040	10900	18000	11250	18310	11280	19470	11140	20270	10720
	54	15320	10200	16030	10480	17040	10900	18000	11250	18310	11280	19470	11140	20270	10720
	57	15320	10200	16030	10480	17040	10900	18000	11250	18310	11280	19470	11140	20270	10720
	61	15320	10200	16030	10480	17040	10900	18000	11250	18310	11280	19470	11140	20270	10720
	64	15320	10200	16030	10480	17040	10900	18000	11250	18310	11280	19470	11140	20270	10720
	68	15320	10200	16030	10480	17040	10900	18000	11250	18310	11280	19470	11140	20270	10720
	70	15320	10200	16030	10480	17040	10900	18000	11250	18310	11280	19470	11140	20270	10720
	73	15320	10200	16030	10480	17040	10900	18000	11250	18310	11280	19470	11140	20270	10720
	77	15320	10200	16030	10480	17040	10900	18000	11250	18310	11280	19470	11140	20270	10720
	81	15320	10200	16030	10480	17040	10900	18000	11250	18310	11280	19470	11140	20270	10720
	84	15320	10200	16030	10480	17040	10900	18000	11250	18310	11280	19470	11140	20270	10720
	88	15320	10200	16030	10480	17040	10900	18000	11250	18310	11280	19470	11140	20270	10720
	91	15320	10200	16030	10480	17040	10900	18000	11250	18310	11280	19470	11140	20270	10720
95	15320	10200	16030	10480	17040	10900	18000	11250	18310	11280	19470	11140	20270	10720	
99	14880	9900	15570	10180	16550	10580	17480	10920	17780	10950	18910	10820	19680	10410	
102	14520	9670	15200	9940	16150	10330	17060	10670	17360	10690	18460	10560	19220	10160	
024	50	20430	13790	21370	14170	22730	14750	24000	15210	24410	15250	25960	15060	27020	14490
	54	20430	13790	21370	14170	22730	14750	24000	15210	24410	15250	25960	15060	27020	14490
	57	20430	13790	21370	14170	22730	14750	24000	15210	24410	15250	25960	15060	27020	14490
	61	20430	13790	21370	14170	22730	14750	24000	15210	24410	15250	25960	15060	27020	14490
	64	20430	13790	21370	14170	22730	14750	24000	15210	24410	15250	25960	15060	27020	14490
	68	20430	13790	21370	14170	22730	14750	24000	15210	24410	15250	25960	15060	27020	14490
	70	20430	13790	21370	14170	22730	14750	24000	15210	24410	15250	25960	15060	27020	14490
	73	20430	13790	21370	14170	22730	14750	24000	15210	24410	15250	25960	15060	27020	14490
	77	20430	13790	21370	14170	22730	14750	24000	15210	24410	15250	25960	15060	27020	14490
	81	20430	13790	21370	14170	22730	14750	24000	15210	24410	15250	25960	15060	27020	14490
	84	20430	13790	21370	14170	22730	14750	24000	15210	24410	15250	25960	15060	27020	14490
	88	20430	13790	21370	14170	22730	14750	24000	15210	24410	15250	25960	15060	27020	14490
	91	20430	13790	21370	14170	22730	14750	24000	15210	24410	15250	25960	15060	27020	14490
95	20430	13790	21370	14170	22730	14750	24000	15210	24410	15250	25960	15060	27020	14490	
99	19840	13390	20750	13760	22070	14320	23300	14770	23700	14810	25210	14620	26240	14070	
102	19370	13070	20260	13430	21550	13980	22750	14420	23140	14460	24610	14280	25610	13740	

TC : Total capacity [Btu/h]
 SHC : Sensible capacity [Btu/h]

8. Air flow distance chart

MML-AP0074H2UL, AP0094H2UL

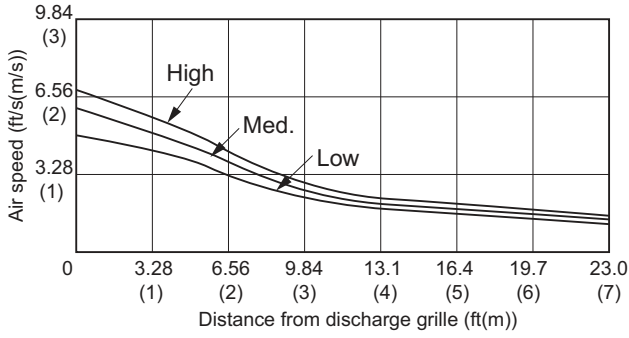

MML-AP0124H2UL, AP0154H2UL

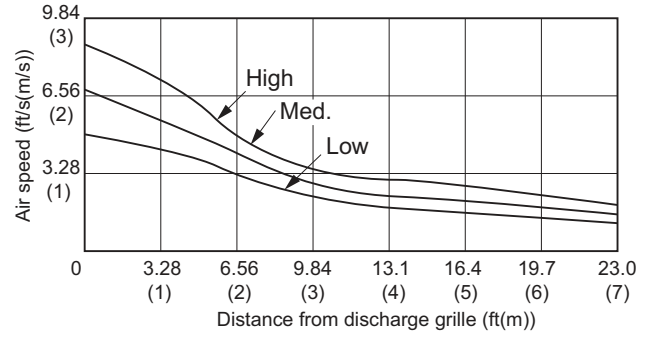

MML-AP0184H2UL, AP0244H2UL

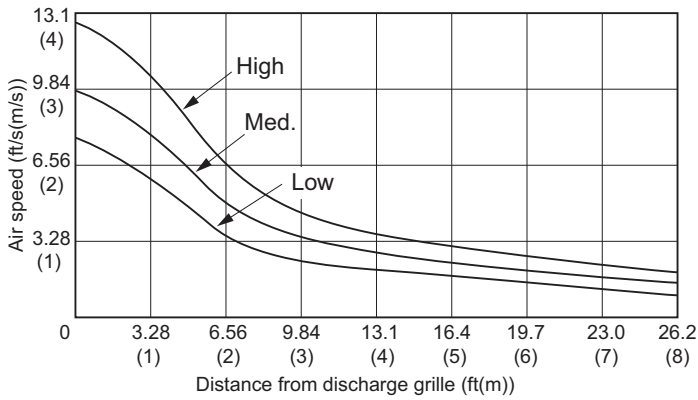

9. Sound data

Sound pressure spectrum

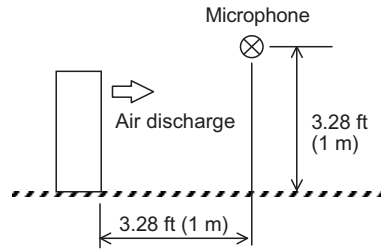

MML-AP0074H2UL, AP0094H2UL
Power source: 208V/60Hz

Fan tap	H	M	L
Sound pressure level (dB(A))	39	38	35

MML-AP0074H2UL, AP0094H2UL
Power source: 230V/60Hz

Fan tap	H	M	L
Sound pressure level (dB(A))	42	40	38

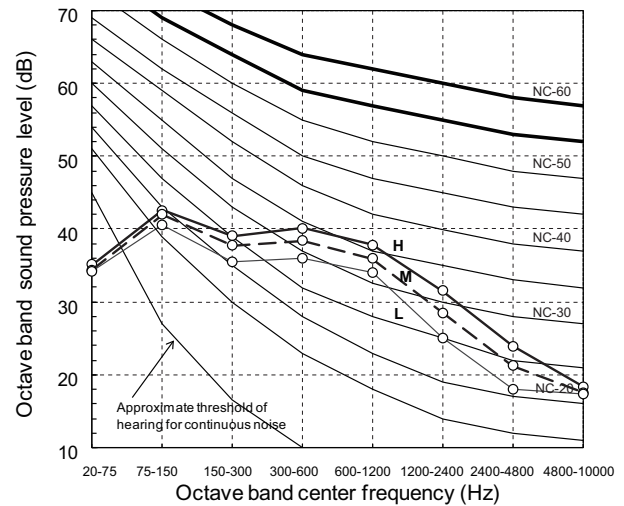
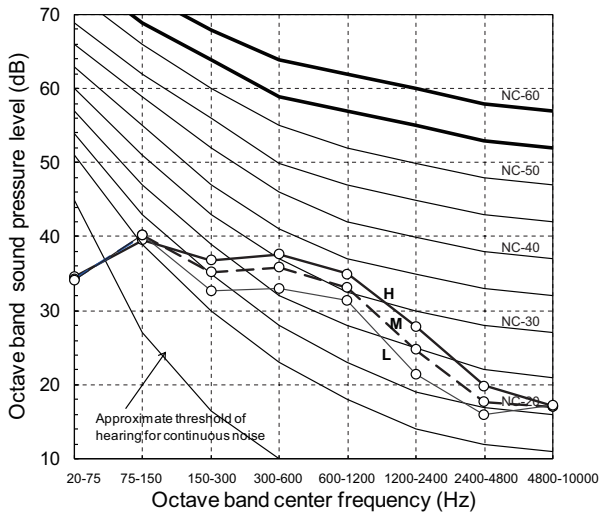

MML-AP0124H2UL, AP0154H2UL
Power source: 208V/60Hz

Fan tap	H	M	L
Sound pressure level (dB(A))	47	44	40

MML-AP0124H2UL, AP0154H2UL
Power source: 230V/60Hz

Fan tap	H	M	L
Sound pressure level (dB(A))	50	46	42

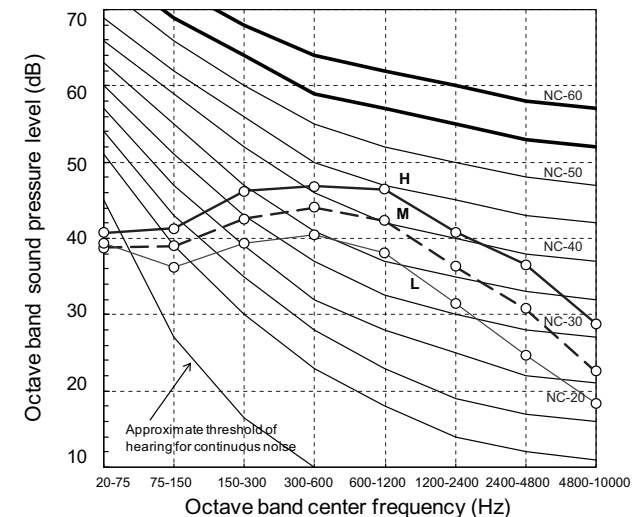
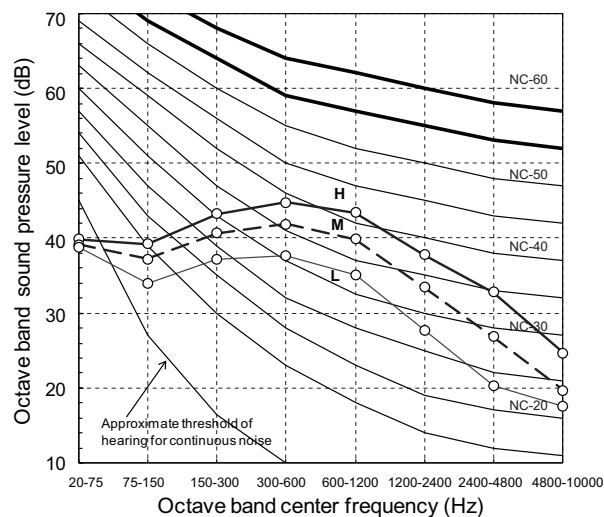

MML-AP0184H2UL, AP0244H2UL
Power source: 208V/60Hz

Fan tap	H	M	L
Sound pressure level (dB(A))	51	46	41

MML-AP0184H2UL, AP0244H2UL
Power source: 230V/60Hz

Fan tap	H	M	L
Sound pressure level (dB(A))	53	48	43

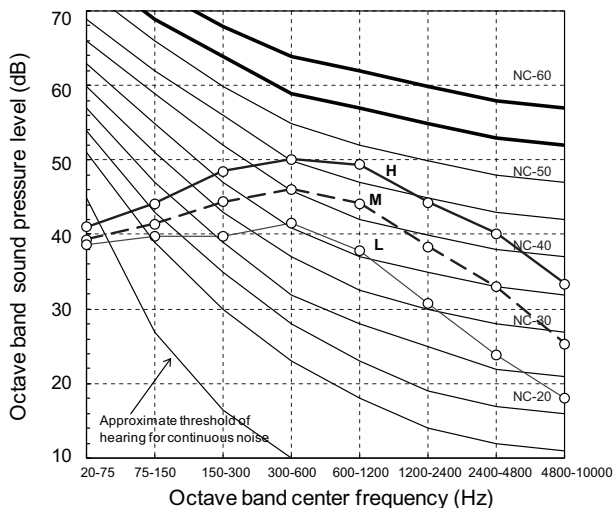
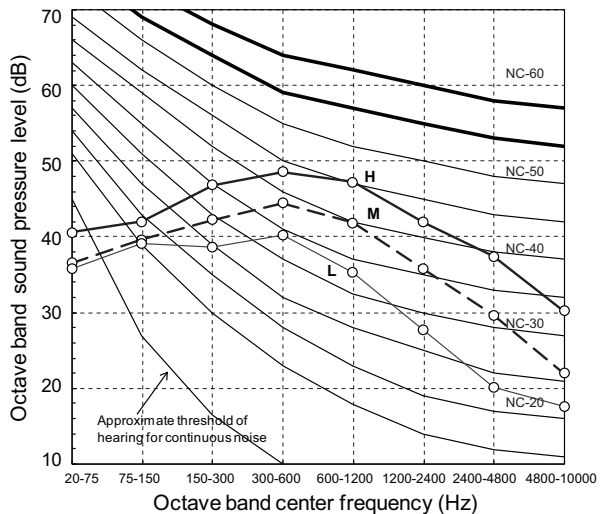

Floor Console Exposed Type Engineering Data Book

Model name:

MML-AP__4H2UL

July, 2016 Second Edition

TOSHIBA CARRIER CORPORATION